

# LIGHT DUTY TRUCK

10-30 SERIES

# SHOP MANUAL



ST-330-83

1983 CHEVROLET

| FOR  | CONTACT   |
|--|---|
| ORDERING SHOP MANUALS<br>(CURRENT AND PAST MODELS)   | HELM, INC.<br>P.O. BOX 07130<br>DETROIT, MICH. 48203  |
| INQUIRIES ON YOUR VEHICLE, SUCH AS: <ul style="list-style-type: none"> <li>● VEHICLE PERFORMANCE QUESTIONS</li> <li>● TECHNICAL ASSISTANCE/INFORMATION</li> <li>● COMPONENT IDENTIFICATION</li> <li>● DIAGNOSIS</li> </ul> | <ol style="list-style-type: none"> <li>1. LOCAL CHEVROLET DEALER</li> <li>2. LOCAL CHEVROLET ZONE OFFICE<br/>(SEE LISTING IN YOUR OWNERS MANUAL)</li> </ol> |
| <ul style="list-style-type: none"> <li>● SUGGESTED IMPROVEMENTS TO SHOP MANUAL</li> <li>● ERRORS/OMISSIONS IN SHOP MANUAL</li> </ul>   | CHEVROLET MOTOR DIVISION<br>GENERAL MOTORS CORPORATION<br>SERVICE PUBLICATIONS<br>30007 VAN DYKE<br>WARREN, MICH. 48090                                     |



## **CAUTION**

**To reduce the chance of personal injury and/or property damage, the following instructions must be carefully observed:**

**Proper service and repair are important to the safety of the service technician and the safe, reliable operation of all motor vehicles. If part replacement is necessary, the part must be replaced with one of the same part number or with an equivalent part. Do not use a replacement part of lesser quality.**

**The service procedures recommended and described in this service manual are effective methods of performing service and repair. Some of these procedures require the use of tools specially designed for the purpose.**

**Accordingly, anyone who intends to use a replacement part, service procedure or tool, which is not recommended by the vehicle manufacturer, must first determine that neither his safety nor the safe operation of the vehicle will be jeopardized by the replacement part, service procedure or tool selected.**

**It is important to note that this manual contains various "Cautions" and "Notices" that must be carefully observed in order to reduce the risk of personal injury during service or repair, or the possibility that improper service or repair may damage the vehicle or render it unsafe. It is also important to understand that these 'Cautions' and 'Notices' are not exhaustive, because it is impossible to warn of all the possible hazardous consequences that might result from failure to follow these instructions.**

# 1983 LIGHT DUTY TRUCK (Series 10-35) SHOP MANUAL

## FORWARD

This manual includes procedures for diagnosis, maintenance and adjustments, minor service operations, removal and installation of components and disassembly and assembly of major components of Chevrolet Light Duty Trucks.

The Section Index on the contents page enables the user to quickly locate any desired section. At the beginning of each section containing more than one major subject is a Table of Contents, which gives the page number on which each major subject begins. An index is placed at the beginning of each major subject within the section.

Summaries of Special Tools, when required, and specifications are found at end of major sections.

When reference is made in this manual to a brand name, number, or specific tool an equivalent product may be used in place of the recommended item.

This manual should be kept in a handy place for ready reference. If properly used, it will enable the technician to better serve the owners of Chevrolet built vehicles.

All information, illustrations and specifications contained in this literature are based on the latest product information available at the time of publication approval. The right is reserved to make changes at any time without notice.

### CAUTION

*This vehicle contains many parts dimensioned in the metric system. Most fasteners are metric and many are very close in dimension to familiar customary measurements in the inch system. However, it is important to note that, during any vehicle maintenance procedures, replacement fasteners must have the same measurements as those removed, whether metric or customary. Mismatched or incorrect fasteners can result in vehicle damage or malfunction, or possibly personal injury. Therefore, fasteners removed from the vehicle should be saved for re-use whenever possible. Where the fasteners are not satisfactory for re-use, care should be taken to select a replacement that matches the original.*

*Additional information concerning this subject will be found following the specifications section at the end of this manual.*

CHEVROLET MOTOR DIVISION

General Motors Corporation  
DETROIT, MICHIGAN

| TABLE OF CONTENTS  | SECTION   |
|--|---|
| <b>GENERAL INFORMATION</b><br>General Information<br>Maintenance and Lubrication   | 0A<br>0B  |
| <b>HEATING AND AIR CONDITIONING</b><br>Heating and Ventilation<br>Air Conditioning<br>A-6 Compressor   | 1A<br>1B<br>1D  |
| <b>FRAME AND BUMPERS</b><br>Frame and Body Mounts<br>Bumpers<br>Sheet Metal<br>Body  | 2A<br>2B<br>2C<br>2D  |
| <b>STEERING, SUSPENSION, WHEELS AND TIRES</b><br>Front Alignment<br>Steering Linkage<br>Manual Steering<br>Power Steering<br>Steering Column<br>Front Suspension<br>Rear Suspension<br>Wheel and Tires   | 3A<br>3B1<br>3B2<br>3B3<br>3B4<br>3C<br>3D<br>3E  |
| <b>PROPELLER SHAFT AND AXLES</b><br>Propeller Shaft<br>Rear Axles<br>Front Axle  | 4   |
| <b>BRAKES</b>  | 5   |
| <b>ENGINE</b><br>Engine Diagnosis<br>In-Line 6 (4.1L/4.8L)<br>Small Block (5.0L/5.7L)<br>Mark IV (7.4L)<br>Diesel (6.2L)<br>Engine Coding<br>Engine Fuel<br>E4ME Carburetor<br>E2SE Carburetor<br>1ME Carburetor<br>2SE Carburetor<br>M4ME Carburetor<br>Diesel Fuel Injection<br>Engine Electrical<br>Emission Controls — Carburetor<br>Emission Controls — Diesel<br>Engine Exhaust<br>Vacuum Pump | 6<br><br><br><br><br><br>6B<br>6C<br>6C1<br>6C3<br>6C7<br>6C9<br>6C10<br><br>6D<br>6E1<br>6E3<br>6F<br>6H |
| <b>TRANSMISSION</b><br>Automatic Service<br>350C-Unit Repair<br>400-Unit Repair<br>700R4-Unit Repair<br>Manual-Service<br>3 Speed 76mm-Unit Repair<br>4 Speed 89mm-Unit Repair<br>4 Speed 117mm-Unit Repair<br>Clutch<br>Transfer Case-205<br>Transfer Case-208  | 7   |
| <b>ELECTRICAL — BODY AND CHASSIS</b><br>Chassis Electrical<br>Instrument Panel and Gages   | 8B<br>8C  |
| <b>ACCESSORIES</b>   | 9   |
| <b>ELECTRICAL WIRING DIAGRAMS</b>  | <b>REAR OF BOOK</b>   |

## SECTION 0A

# GENERAL INFORMATION

### CONTENTS

|                                      |      |                                       |       |
|--------------------------------------|------|---------------------------------------|-------|
| General Information .....            | 0A-1 | Unit and Serial Number Location ..... | 0A-4  |
| Vehicle Identification Numbers ..... | 0A-1 | Capacities .....                      | 0A-6  |
| Service Parts Identification .....   | 0A-1 | Lubrication Points .....              | 0A-7  |
| Vehicle Loading .....                | 0A-1 | Metric Information .....              | 0A-9  |
| Engine Code Number .....             | 0A-2 | Common Abbreviations .....            | 0A-16 |

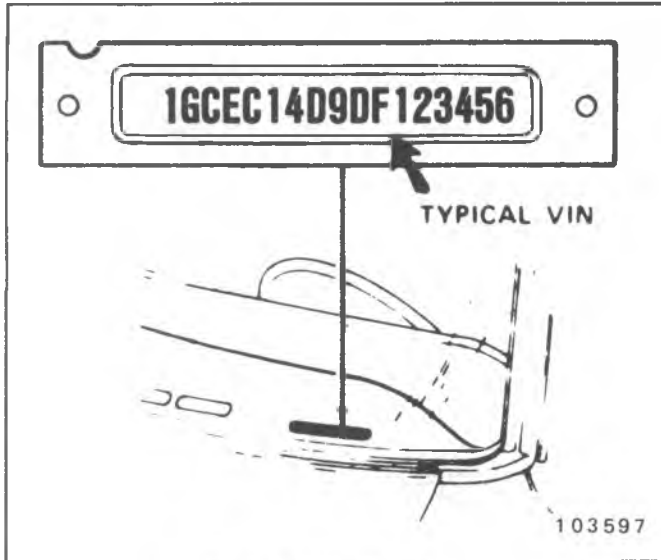

Fig. 0A-1 -- V.I.N. Location

### GENERAL INFORMATION

Information to identify the vehicle and vehicle components appears in this section. Detailed specifications on major units are given at the end of each respective section in this manual.

### VEHICLE IDENTIFICATION NUMBER (VIN)

This is the legal identification of the vehicle. It appears on a plate which is attached to the left top of the instrument panel on CK and G truck and can be easily seen through the windshield from outside the vehicle (Fig. 0A-1). On P10-20-30 models, the plate is attached to the front of the dash and toe panel to the left of steering column (Fig. 0A-2). The VIN (Fig. 0A-3) also appears on the Vehicle Certificates of Title and Registrations.

### SERVICE PARTS IDENTIFICATION STICKER

The Service Parts Identification Sticker (Fig. 0A-4) is provided on all Truck models. On C and K models, the identification sticker is located on the inside of the glove box door or on G model, the sticker will be located on an inner hood panel surface. On P models, the sticker is located on an inner body panel.

The plate lists the vehicle identification number, wheelbase, and all Production options or Special Equipment on the vehicle when it was shipped from the factory including paint information. **ALWAYS REFER TO THIS INFORMATION WHEN ORDERING PARTS.**

### VEHICLE LOADING

Vehicle loading must be controlled so weights do not exceed the numbers shown on the Vehicle Identification Number and/or Rating Plate for the vehicle.

A typical example of a truck in a loaded condition is shown in Figure 0A-5. Note that the axle or GVW capabilities are not exceeded.

### ENGINE CODE NUMBER

The engine code number indicates manufacturing plant, month and day of manufacture, and transmission type. A typical engine number would be F1210TTBB, which would breakdown thus:

- F - Manufacturing Plant (F-Flint, T-Tonawanda)
- 12 - Month of Manufacture (December)
- 10 - Day of Manufacture (tenth)
- T - Truck
- TBB - Transmission and engine type

### UNIT AND SERIAL NUMBER LOCATIONS

For the convenience of service technicians and engines when writing up certain business papers such as Warranty Reports, Product Information Reports, or reporting product failures in any way, the location of the various unit numbers have been indicated. These unit numbers and their prefix or suffix are necessary on these papers for various reasons - such as accounting, follow-up on production, etc.

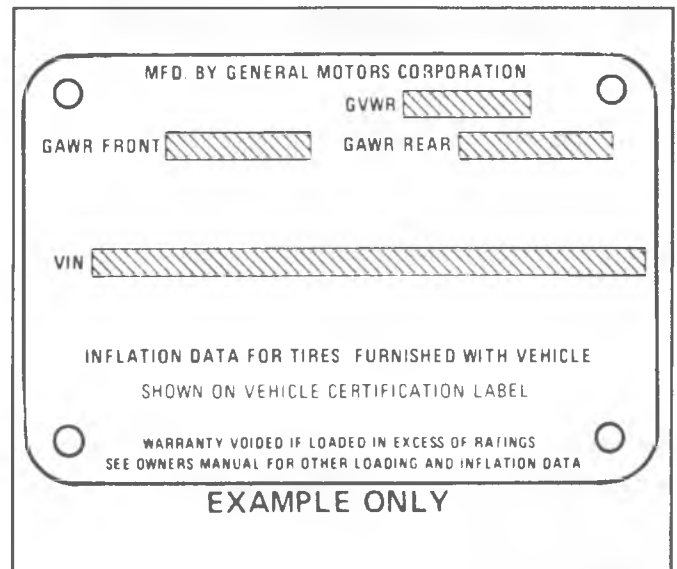
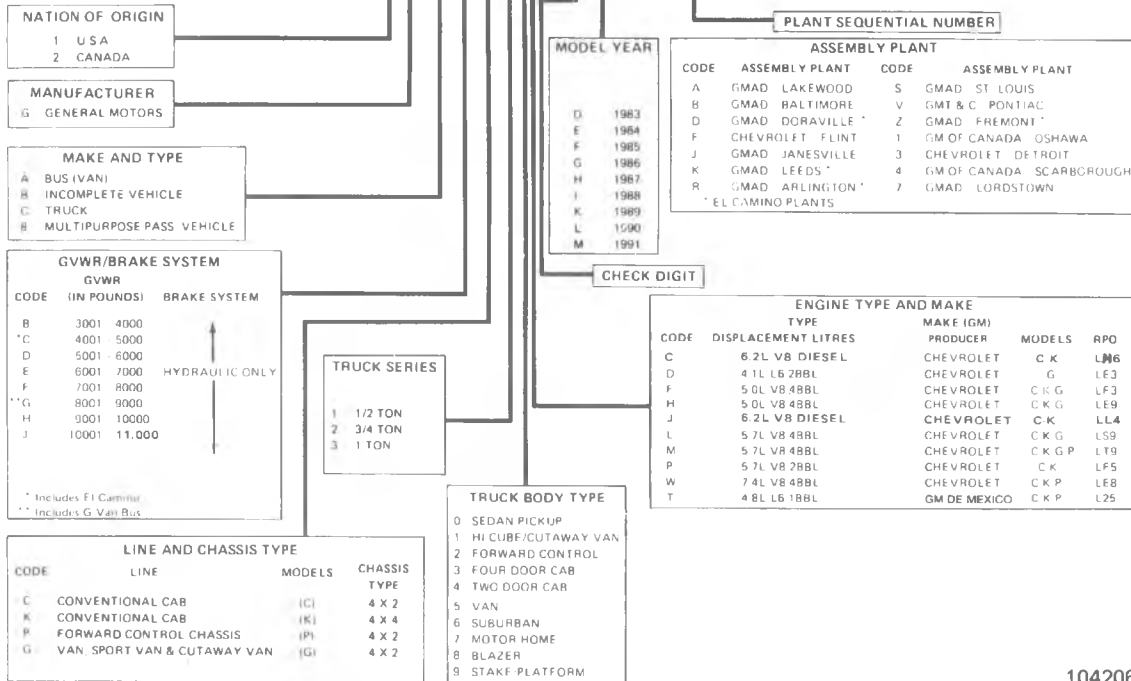

Fig. 0A-2 -- V.I.N. Rating Plate (P Model)



# VEHICLE IDENTIFICATION NUMBER

1GCEC14D9DF123456



104206

Fig. 0A-3 -- Vehicle Identification Number Codes, CKGP, Truck

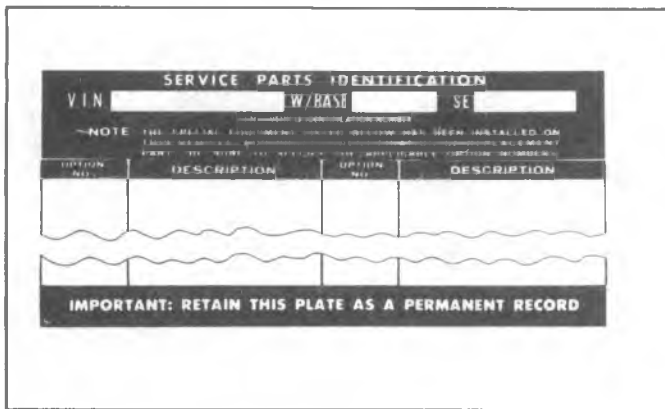

Fig. 0A-4 -- Service Parts Identification Plate

The prefixes on certain units identify the plant in which the unit was manufactured and thereby permits proper follow-up of the plant involved to get corrections made when necessary.

Always include the prefix in the number.

## Axles

### Chevrolet Built

- On 10 Series, the Code is stamped on Top of Right Rear Axle Tube.
- On 20-30 Series, the Code is stamped on Top of the Right Rear Axle Tube.

### Dana Built

- On Front Axles, code is stamped on Top Rear of Left Axle Tube.
- On Rear Axles, code is stamped on Rear Surface of Right Axle Tube.

**LOADED—MAXIMUM GVWR: 4900-LBS.**  
**FRONT GAWR: 2944 LBS. REAR GAWR: 2944 LBS.**

|                          |                  |                         |                  |
|--------------------------|------------------|-------------------------|------------------|
| *Front Curb              | 2219 lbs.        | *Rear Curb              | 1003 lbs.        |
| Front Cargo & Pass. Load | 284 lbs.         | Rear Cargo & Pass. Load | 1394 lbs.        |
|                          | <u>2503 lbs.</u> |                         | <u>2397 lbs.</u> |

**TOTAL WEIGHT AT GROUND: 4900 lbs.**

\*Curb weight equals the weight of the vehicle without driver, passenger or cargo, but including fuel and coolant.

Fig. 0A-5 -- Typical Vehicle Loading Condition

**Transmissions (Fig. 0A-6)**

- On 3-Speed Transmissions (except Tremec), the Unit Number is located on Lower Left Side of Case Just Below Cover.
- On Tremec Transmission, Unit Number is located on Upper Left Attachment Case (Top Side).
- On Muncie 4-Speeds, Unit Number is located on Rear Face of Case below Retainer.
- On New Process 205 model 4-wheel drive transfer case, a build date is on tag attached to front face of transfer case.
- On Automatic 350 Transmission, Unit Number is located on Right Rear Vertical Surface of Oil Pan.
- On the Automatic 400 Transmission, Serial Number is location on the Light Blue Plate on the Right Side of the Transmission.

**Engines (Fig. 0A-7)**

- 6-Cylinder Engine Unit Number Located on Pad at Right Hand Side of Cylinder Block at Rear of Distributor.

- 8-Cylinder Gasoline Engine Code is (305, 350, 400 CID) Located on Pad immediately forward of right hand cylinder head.
- 8-Cylinder Gasoline Engine (454 CID) Code is located on a pad of the front top center of the engine block immediately forward of the inlet manifold.
- 8-Cylinder Diesel Engine Code is on a label located on rear face of the left valve cover.

**Generators**

Generator Unit Serial Number is located on the Drive End Frame Below the Part Number.

**Batteries**

Battery Code Number is Located on Cell Cover Top of Battery.

**Starters**

Starter Serial Number and Production Date are Stamped on Outer Case, Toward Rear.

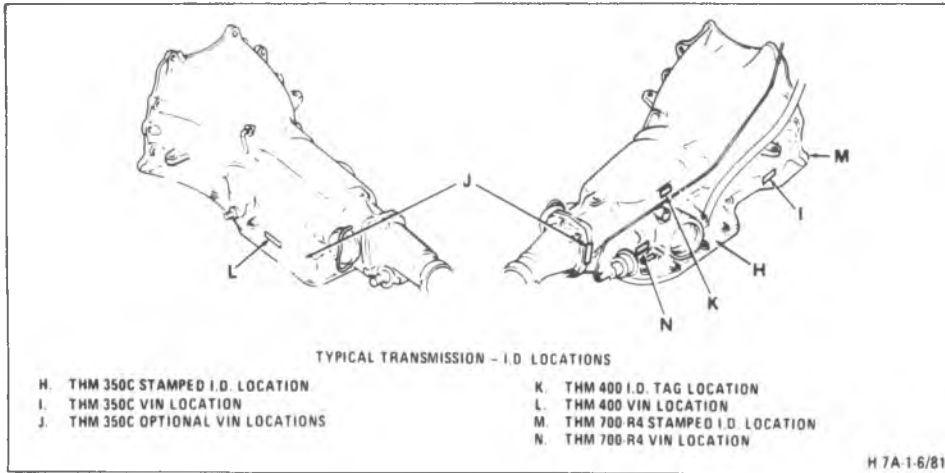

**TRANSMISSION IDENTIFICATION**

FOR: THM 350C - TOLEDO PLANT, OHIO

Y    3    E    03    D

---

Y = SOURCE (Y = TOLEDO    B = PARMA)  
 3 = MODEL YEAR  
 E = MONTH (A = JAN    B = FEB)  
 03 = DAY  
 D = SHIFT (D = DAY SHIFT    N = NIGHT SHIFT)

H 7A-8-6/81

**TRANSMISSION NAMEPLATE**  
 YPSILANTI PLANT, MICHIGAN

THM 400

P · Z

83-PZ 86992

83 = MODEL YEAR  
 PZ = MODEL  
 86992 = SERIAL NO.

H 7A-12-6/81

**TRANSMISSION NAMEPLATE**  
 BUICK-FLINT PLANT, MICHIGAN  
 THM 350C

L · D

9LD 001D 83

9LD = MODEL CODE (1982 LD)  
 001 = PRODUCTION BUILD DATE  
 D = SHIFT (D = DAY SHIFT)  
 83 = YEAR

H 7A-9-6/81

**TRANSMISSION IDENTIFICATION**  
 THM 700R4 - TOLEDO PLANT, OHIO

9    TA    Y    83    M    12    D

---

9 = MODEL YEAR  
 TA = MODEL  
 Y = TOLEDO  
 83 = YEAR  
 M = MONTH  
 12 = DAY  
 D = SHIFT (D = DAY    N = NIGHT)

H 7A-7-6/81

Fig. 0A-6 -- Transmission V.I.N. Location



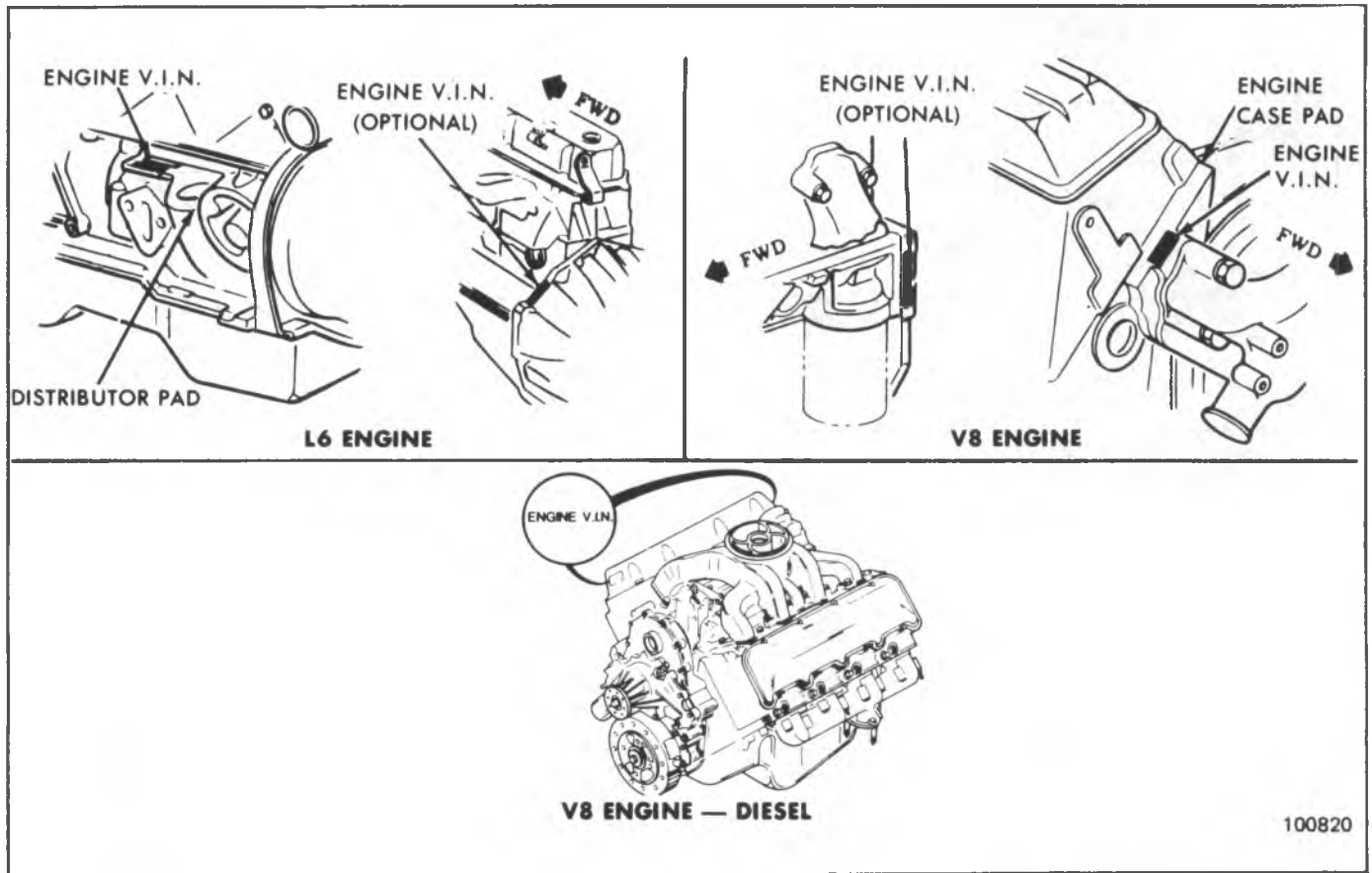

Fig. 0A-7 -- Engine V.I.N. Location

**APPROXIMATE CAPACITIES – PICKUP MODELS**

| ITEMS                               | Metric Measure | U.S. Measure |
|-------------------------------------|----------------|--------------|
| Cooling System (approx.)<br>All L-6 |                |              |
| Without A/C                         | 14 Liters      | 15 Quarts    |
| With A/C                            | 14.7 Liters    | 15.5 Quarts  |
| Code F,H,L & M – V-8                |                |              |
| Without A/C                         | 16.6 Liters    | 17.5 Quarts  |
| With A/C                            | 17 Liters      | 18 Quarts    |
| Code W – V-8                        |                |              |
| Without A/C                         | 22 Liters      | 23 Quarts    |
| With A/C                            | 23 Liters      | 24.5 Quarts  |
| Diesel                              |                |              |
| Without A/C                         | 22 Liters      | 23 Quarts    |
| With A/C                            | 23 Liters      | 24.5 Quarts  |
| Crankcase *                         |                |              |
| Gasoline Engines                    |                |              |
| Codes: D,F,H,L,M                    |                |              |
| Without Filter                      | 3.8 Liters     | 4 Quarts     |
| With Filter                         | 4.8 Liters     | 5 Quarts     |
| Code: T                             |                |              |
| Without Filter                      | 4.8 Liters     | 5 Quarts     |
| With Filter                         | 5.7 Liters     | 6 Quarts     |
| Code: W +                           |                |              |
| Without Filter                      | 5.7 Liters     | 6 Quarts     |
| With Filter                         | 6.5 Liters     | 7 Quarts     |
| Diesel Engines                      |                |              |
| Code: C,J †                         | 6.5 Liters     | 7 Quarts     |
| Fuel Tank (approx.)                 |                |              |
| Short Bed –                         |                |              |
| Single Tank, Gas, Diesel            | 61 Liters      | 16 Gallons   |
| *Dual Tanks, Gas, Diesel            | 61 Liters      | 16 Gallons   |
| Long Bed –                          |                |              |
| Single Tank, Gas                    | 76 Liters      | 20 Gallons   |
| @Dual Tanks, Gas                    | 61 Liters      | 16 Gallons   |
| Single Tank, Diesel                 | 76 Liters      | 20 Gallons   |
| *Dual Tanks, Diesel                 | 76 Liters      | 20 Gallons   |
| Front Axle                          | 2.4 Liters     | 2.5 Quarts   |
| Transfer Case                       |                |              |
| 10-20 Series                        | 4.8 Liters     | 5 Quarts     |
| 30 Series                           | 2.4 Liters     | 2.5 Quarts   |

**APPROXIMATE CAPACITIES – BLAZER, SUBURBAN**

| ITEMS                     | Metric Measure | U.S. Measure |
|---------------------------|----------------|--------------|
| Cooling System (approx.)  |                |              |
| Code: H, L, M             |                |              |
| Without A/C               | 16.5 Liters    | 17.5 Quarts  |
| With A/C                  | 17 Liters      | 18 Quarts    |
| Code: W                   |                |              |
| Without A/C               | 22 Liters      | 23 Quarts    |
| With A/C                  | 23 Liters      | 24.5 Quarts  |
| Diesel Engines            |                |              |
| Code: C, J                |                |              |
| Without A/C               | 23 Liters      | 24.5 Quarts  |
| With A/C                  | 23 Liters      | 24.5 Quarts  |
| Crankcase *               |                |              |
| Gasoline Engines          |                |              |
| Code: H, L and M          |                |              |
| Without Filter            | 3.8 Liters     | 4 Quarts     |
| With Filter               | 4.8 Liters     | 5 Quarts     |
| Code: W +                 |                |              |
| Without Filter            | 5.7 Liters     | 6 Quarts     |
| With Filter               | 6.5 Liters     | 7 Quarts     |
| Diesel Engines †          |                |              |
| Code: C, J                |                |              |
| With Filter               | 6.5 Liters     | 7 Quarts     |
| Front Axle                | 2.4 Liters     | 2.5 Quarts   |
| Transfer Case             | 4.8 Liters     | 5.0 Quarts   |
| Fuel Tank                 |                |              |
| Standard, All – Gas       | 95 Liters      | 25 Gallons   |
| – Diesel                  | 102 Liters     | 27 Gallons   |
| NK7 Option, All – Gas     | 117 Liters     | 31 Gallons   |
| – Diesel                  | 121 Liters     | 32 Gallons   |
| NE2 Option, Suburban Only |                |              |
| – Gas                     | 151 Liters     | 40 Gallons   |
| – Diesel                  | 155 Liters     | 41 Gallons   |

- ♦ After refill, fluid level must be checked.
- + K30 Models – 5 U.S. Quarts (4.8 Liters)
- † Oil Filter should be changed at EVERY oil change.
- \* Listed quantity if for each tank.
- @ Above 8600 GVWR—Both tanks 20 gallons (76 Liters)

- ♦ After refill, fluid level must be checked.
- + K30 Models – 5 U.S. Quarts (4.8 Liters).
- † Oil Filter should be changed at EVERY oil change.

**APPROXIMATE CAPACITIES – ALL MODELS**

| ITEMS                  | Metric Measure | U.S. Measure |
|------------------------|----------------|--------------|
| Differential           |                |              |
| 8½" Ring Gear          | 1.9L           | 4¼ pts.      |
| 8-7/8" Ring Gear       |                | 3½ pts.      |
| 10½" Ring Gear (Chev.) | 2.8L           | 6½ pts.      |
| 10½" Ring Gear (Dana)  | 3L             | 7.2 pts.     |
| 9¾" Ring Gear (Dana)   | 2.6L           | 6.0 pts.     |
| 12¼" Ring Gear (Dana)  | 11.7L          | 26.8 pts.    |
| Transmission           |                |              |
| Automatic              |                |              |
| 350 – Total            | 9.5L           | 10 qts.      |
| – Refill               | 2.8L           | 3 qts.       |
| 400 – Total            | 10.4L          | 11 qts.      |
| – Refill               | 3.8L           | 3.5 qts.     |
| 700R4 – Total          | 10.9L          | 11.5 qts.    |
| – Refill               | 4.7L           | 5 qts.       |
| Manual                 |                |              |
| 4 Speed 117mm          | 3.8L           | 4 qts.       |
| 3 Speed 76mm           | 1.4L           | 1.5 qts.     |
| 3 Speed 77mm           | 1.4L           | 1.5 qts.     |

104254

Fig. 0A-8 -- Capacities Chart

### CONVENTIONAL AND FORWARD CONTROL MODELS

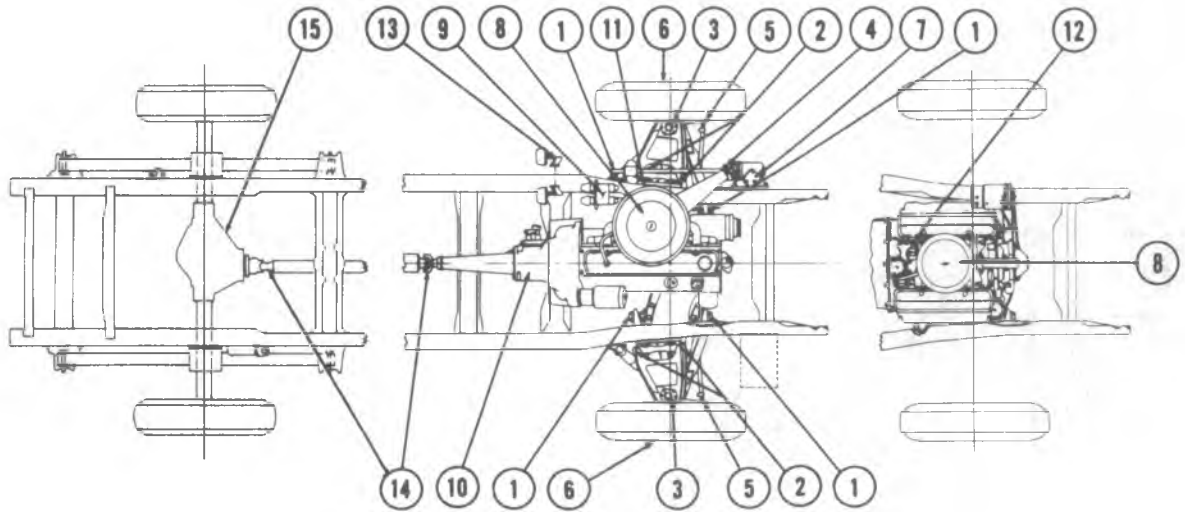

#### LUBRICATION POINTS

- |   |   |                                   |
|---|---|-----------------------------------|
| 1 Lower Control Arms                      | 6 Wheel Bearings                        | 11 Throttle Bell Crank – L-6      |
| 2 Upper Control Arms                      | 7 Steering Gear                         | 12 Carburetor Linkage – V-8       |
| 3 Upper and Lower Control Arm Ball Joints | 8 Air Cleaner – Element                 | 13 Brake and Clutch Pedal Springs |
| 4 Intermediate Steering Shaft (PA10)      | 9 Master Cylinder                       | 14 Universal Joints               |
| 5 Tie Rod Ends                            | 10 Transmission – Manual<br>– Automatic | 15 Rear Axle                      |

### FOUR WHEEL DRIVE MODELS

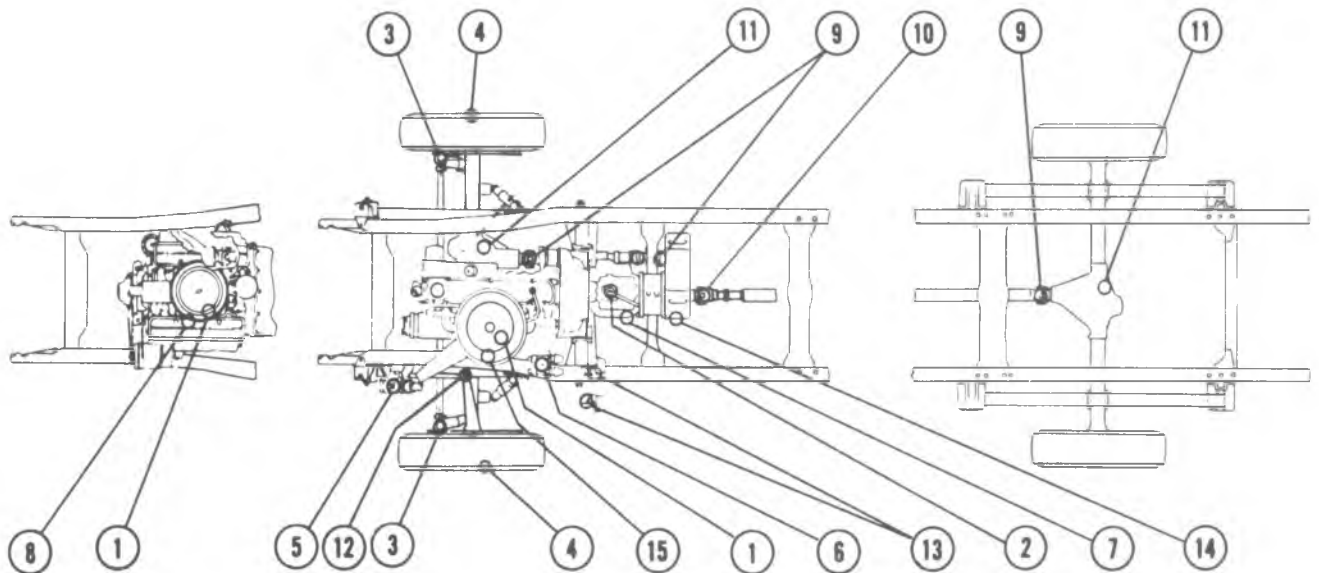

#### LUBRICATION POINTS

- |                          |  |                                   |
|--------------------------|--|-----------------------------------|
| 1 Air Cleaner            | 6 Master Cylinder                      | 11 Front and Rear Axle            |
| 2 Control Linkage Points | 7 Transmission – Manual<br>– Automatic | 12 Drag Link                      |
| 3 Tie Rod Ends           | 8 Carburetor Linkage – V-8             | 13 Brake and Clutch Pedal Springs |
| 4 Wheel Bearings         | 9 Universal Joints                     | 14 Transfer Case                  |
| 5 Steering Gear          | 10 Propeller Shaft Slip Joints         | 15 Throttle Bell Crank – L-6      |

Fig. 0A-9 -- Lubrication Points, CK



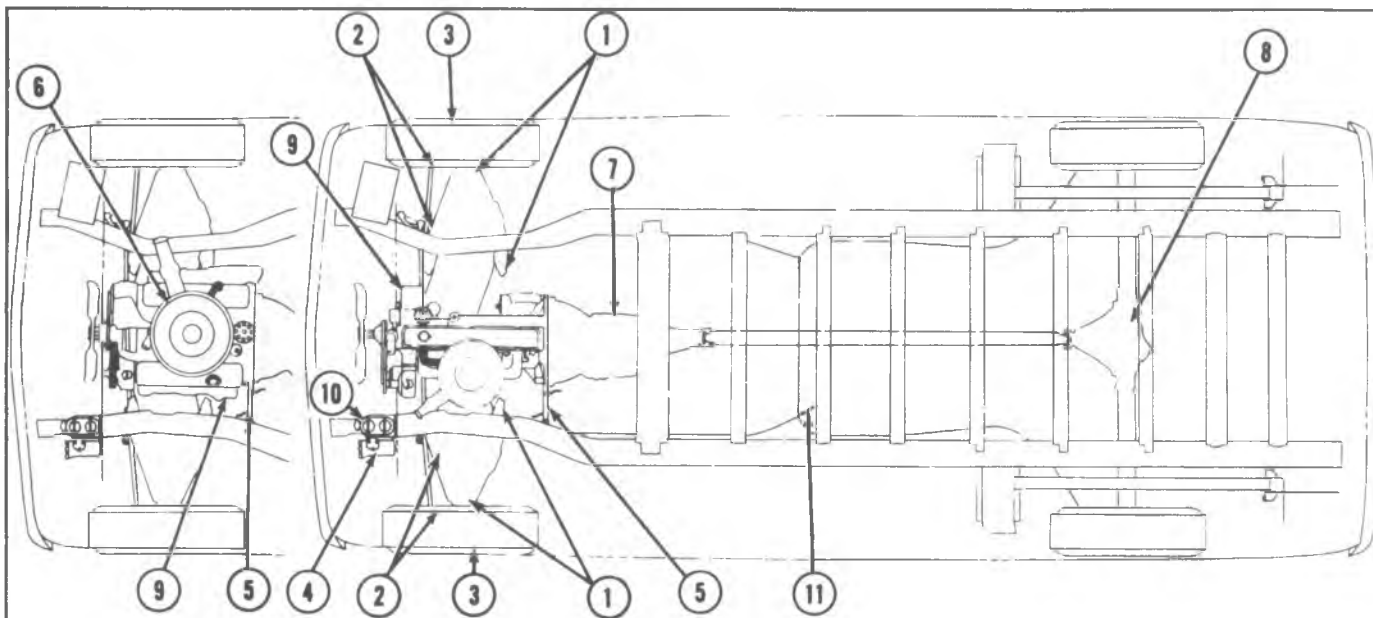

**LUBRICATION POINTS**

- |   |   |   |                                      |    |                       |
|---|---|---|--------------------------------------|----|-----------------------|
| 1 | Control Arm Bushings and<br>Ball Joints | 5 | Trans. Control Shaft                 | 8  | Rear Axle             |
| 2 | Tie Rod Ends                            | 6 | Air Cleaner - Element                | 9  | Oil Filter            |
| 3 | Wheel Bearings                          | 7 | Transmission - Manual<br>- Automatic | 10 | Brake Master Cylinder |
| 4 | Steering Gear<br>Clutch Cross-Shaft     |   |                                      | 11 | Parking Brake Linkage |

Fig. 0A-10 -- Lubrication Points, G

### USE OF METRIC AND CUSTOMARY NUTS, BOLTS AND SCREWS

Some vehicles present special service requirements to the technician due to the use of both metric and customary (inch) type nuts, bolts and screws. Many are metric and some are very close in dimension to customary nuts, bolts and screws in the inch system. Mismatched or incorrect nuts, bolts and screws can result in damage, malfunction or possible personal injury. Nuts, bolts and screws removed from the vehicle should be saved for re-use whenever possible. If they are not re-usable, care should be taken to select a replacement that matches the original.

General Motors Engineering Standards have adopted a portion of the standard metric fastener sizes defined by SI (Système International). This was done to reduce the number of sizes used and yet retain the best strength characteristics in each thread size. For example, the customary 1/4-20 and 1/4-28 screws are replaced by the metric M6.3 x 1 screw which has nearly the same diameter and 25.4 threads per inch. The thread pitch is in between the customary coarse and fine thread pitches.

Metric and customary thread notation differ slightly. The difference is illustrated below.

| CUSTOMARY                             | METRIC  |
|---------------------------------------|---|
| 1/4                                   | M6.3  |
| Thread Major<br>Diameter<br>in Inches | Thread Major<br>Diameter<br>in Millimeters    |
| 20                                    | 1   |
| Number of<br>Threads<br>per Inch      | Distance<br>Between Threads<br>in Millimeters |

Care should be taken when servicing the vehicle to guard against cross threading or improper retention due to interchanged metric and inch nuts and bolts.

When obtaining metric or customary nuts, bolts, and screws locally for servicing the vehicle, care must be exercised in selecting parts that are equivalent to the original parts in dimensions, strength, and pitch of threads.

Fig. 0A-11 -- Metric Information, Chart A

## REUSE OF PREVAILING TORQUE NUT(S) AND BOLT(S)

PREVAILING TORQUE NUTS ARE THOSE NUTS WHICH INCORPORATE A SYSTEM TO DEVELOP AN INTERFERENCE BETWEEN NUT AND BOLT THREADS INTERFERENCE IS MOST COMMONLY ACHIEVED BY DISTORTING TOP OF ALL-METAL NUT, BUT ALSO MAY BE ACHIEVED BY DISTORTING AT MIDDLE OF HEX FLAT, BY NYLON PATCH ON THREADS, BY NYLON WASHER INSERT AT TOP OF NUT AND BY NYLON INSERT THROUGH NUT.

PREVAILING TORQUE BOLTS ARE THOSE BOLTS WHICH INCORPORATE A SYSTEM TO DEVELOP AN INTERFERENCE BETWEEN BOLT AND NUT OR TAPPED HOLE THREADS. INTERFERENCE IS ACHIEVED BY DISTORTING SOME OF THE THREADS (SEVERAL METHODS EXIST), BY APPLYING A NYLON PATCH OR STRIP OR BY ADHESIVE COATING ON THREADS.

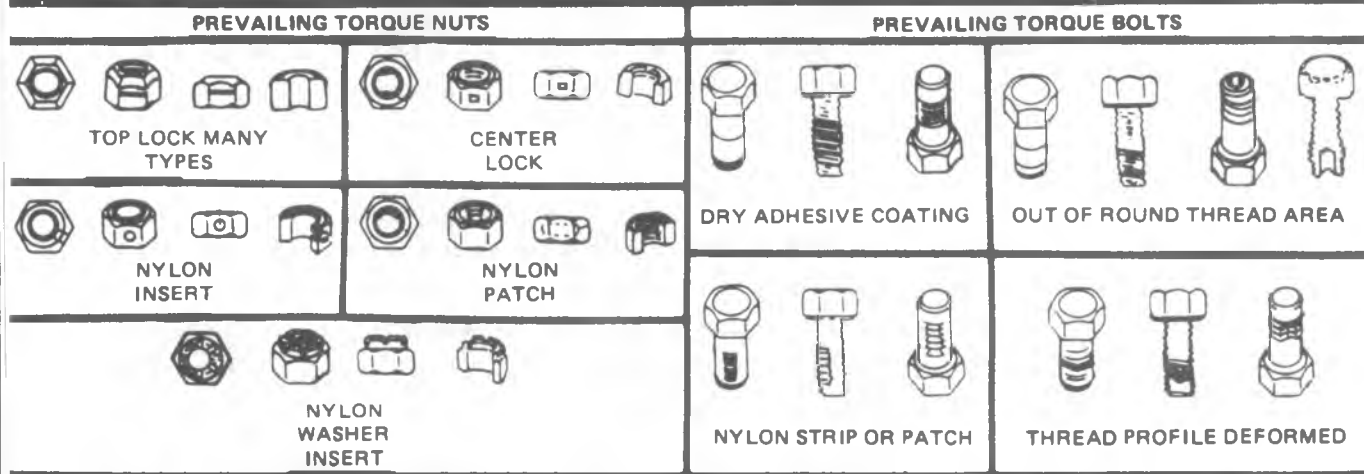

### RECOMMENDATIONS FOR REUSE

- A. CLEAN, UNRUSTED PREVAILING TORQUE BOLTS AND NUTS MAY BE REUSED AS FOLLOWS:
1. CLEAN DIRT AND OTHER FOREIGN MATERIAL OFF NUT AND BOLT
  2. INSPECT BOLT AND NUT TO ASSURE THERE ARE NO CRACKS, ELONGATION OR OTHER SIGNS OF ABUSE OR OVERTIGHTENING. LIGHTLY LUBRICATE THREADS (IF ANY DOUBT, REPLACE WITH NEW PREVAILING TORQUE FASTENER OF EQUAL OR GREATER STRENGTH.)
  3. ASSEMBLE PARTS AND START BOLT OR NUT
  4. OBSERVE THAT BEFORE FASTENER SEATS, IT DEVELOPS PREVAILING TORQUE PER CHART BELOW (IF ANY DOUBT, INSTALL NEW PREVAILING TORQUE FASTENER OF EQUAL OR GREATER STRENGTH).
  5. TIGHTEN TO TORQUE SPECIFIED IN SERVICE MANUAL.
- B. BOLTS AND NUTS WHICH ARE RUSTY OR DAMAGED SHOULD BE REPLACED WITH NEW PARTS OF EQUAL OR GREATER STRENGTH

|                                |          | METRIC SIZES |      |      |      |      |      |      |      |
|--------------------------------|----------|--------------|------|------|------|------|------|------|------|
|                                |          | 6 & 6.3      | 8    | 10   | 12   | 14   | 16   | 20   |      |
| NUTS AND ALL METAL BOLTS       | N·m      | 0.4          | 0.8  | 1.4  | 2.2  | 3.0  | 4.2  | 7.0  |      |
|                                | In. Lbs. | 4.0          | 7.0  | 12   | 18   | 25   | 35   | 57   |      |
| ADHESIVE OR NYLON COATED BOLTS | N·m      | 0.4          | 0.6  | 1.2  | 1.6  | 2.4  | 3.4  | 5.6  |      |
|                                | In. Lbs. | 4.0          | 5.0  | 10   | 14   | 20   | 28   | 46   |      |
|                                |          | INCH SIZES   |      |      |      |      |      |      |      |
|                                |          | .250         | .312 | .375 | .437 | .500 | .562 | .625 | .750 |
| NUTS AND ALL METAL BOLTS       | N·m      | 0.4          | 0.6  | 1.4  | 1.8  | 2.4  | 3.2  | 4.2  | 6.2  |
|                                | In. Lbs. | 4.0          | 5.0  | 12   | 15   | 20   | 27   | 35   | 51   |
| ADHESIVE OR NYLON COATED BOLTS | N·m      | 0.4          | 0.6  | 1.0  | 1.4  | 1.8  | 2.6  | 3.4  | 5.2  |
|                                | In. Lbs. | 4.0          | 5.0  | 9.0  | 12   | 15   | 22   | 28   | 43   |

Fig. 0A-12 -- Metric Information, Chart B



### METRIC BOLT AND NUT IDENTIFICATION

Common metric fastener strength property classes are 9.8 and 10.9 with the class identification embossed on the head of each bolt. Customary (inch) strength classes range from grade 2 to 8 with line identification embossed on each bolt head. Markings correspond to two lines less than the actual grade (i.e. grade 7 bolt will exhibit 5 embossed lines on the bolt head). Some metric nuts will be marked with single digit strength identification numbers on the nut face. The following figure illustrates the different strength markings.

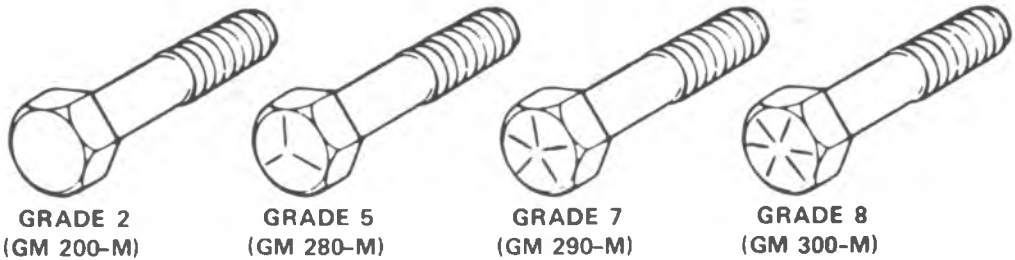

Customary (inch) bolts - Identification marks correspond to bolt strength - Increasing numbers represent increasing strength.

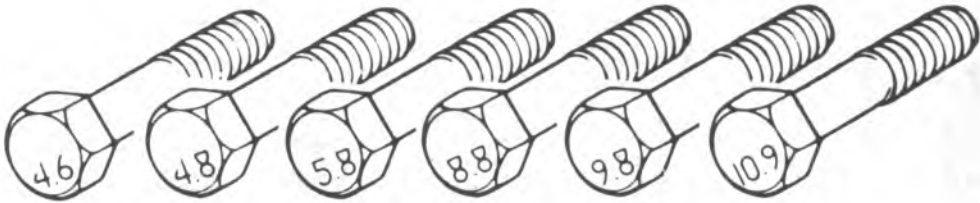

Metric Bolts - Identification class numbers correspond to bolt strength - Increasing numbers represent increasing strength.

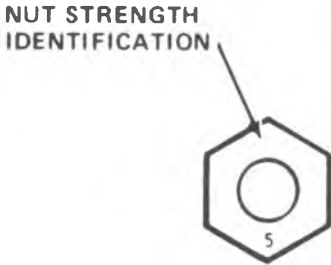
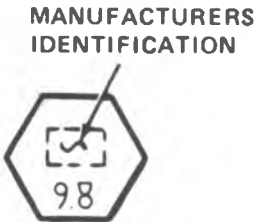

Fig. 0A-13 -- Metric Information, Chart C

SI METRIC-CUSTOMARY CONVERSION TABLE

| Multiply           | by            | to get equivalent number of:                | Multiply                  | by        | to get equivalent number of:                   |
|--------------------|---------------|---|---------------------------|-----------|--|
| <b>LENGTH</b>      |               |   |                           |           |  |
| Inch               | 25.4          | millimeters (mm)                            | Foot/sec <sup>2</sup>     | 0.304 8   | meter/sec <sup>2</sup> (m/s <sup>2</sup> )     |
| Foot               | 0.304 8       | meters (m)                                  | Inch/sec <sup>2</sup>     | 0.025 4   | meter/sec <sup>2</sup>                         |
| Yard               | 0.914 4       | meters                                      | <b>TORQUE</b>             |           |  |
| Mile               | 1.609         | kilometers (km)                             | Pound-inch                | 0.112 98  | newton-meters (N·m)                            |
| <b>AREA</b>        |               |   |                           |           |  |
| Inch <sup>2</sup>  | 645.2         | millimeters <sup>2</sup> (mm <sup>2</sup> ) | Pound-foot                | 1.355 8   | newton-meters                                  |
| Foot <sup>2</sup>  | 6.45          | centimeters <sup>2</sup> (cm <sup>2</sup> ) | <b>POWER</b>              |           |  |
| Yard <sup>2</sup>  | 0.092 9       | meters <sup>2</sup> (m <sup>2</sup> )       | Horsepower                | 0.746     | kilowatts (kW)                                 |
| <b>VOLUME</b>      |               |   |                           |           |  |
| Inch <sup>3</sup>  | 16 387.       | mm <sup>3</sup>                             | <b>PRESSURE OR STRESS</b> |           |  |
| Quart              | 16.387        | cm <sup>3</sup>                             | Inches of mercury         | 3.377     | kilopascals (kPa)                              |
| Gallon             | 0.016 4       | liters (l)                                  | Pounds/sq. in             | 6.895     | kilopascals                                    |
| Yard <sup>3</sup>  | 0.946 4       | liters                                      | <b>ENERGY OR WORK</b>     |           |  |
|                    | 3.785 4       | liters                                      | BTU                       | 1.055     | joules (J)                                     |
|                    | 0.764 6       | meters <sup>3</sup> (m <sup>3</sup> )       | Foot-pound                | 1.355 8   | joules   |
| <b>MASS</b>        |               |   |                           |           |  |
| Pound              | 0.453 6       | kilograms (kg)                              | Kilowatt-hour             | 3 600 000 | joules (J = one W's)                           |
| Ton                | 907.18        | kilograms (kg)                              | <b>LIGHT</b>              |           |  |
| Ton                | 0.907         | tonne (t)                                   | Foot candle               | 10.764    | lumens/meter <sup>2</sup> (lm/m <sup>2</sup> ) |
| <b>FORCE</b>       |               |   |                           |           |  |
| Kilogram           | 9.807         | newtons (N)                                 | <b>FUEL PERFORMANCE</b>   |           |  |
| Ounce              | 0.278 0       | newtons                                     | Miles/gal                 | 0.425 1   | kilometers/liter (km/l)                        |
| Pound              | 4.448         | newtons                                     | Gal/mile                  | 2.352 7   | liters/kilometer (l/km)                        |
| <b>TEMPERATURE</b> |               |   |                           |           |  |
| Degree Fahrenheit  | (°F-32) ÷ 1.8 | degree Celsius (C)                          | <b>VELOCITY</b>           |           |  |
|                    |               |   | Miles/hour                | 1.609 3   | kilometers/hr. (km/h)                          |

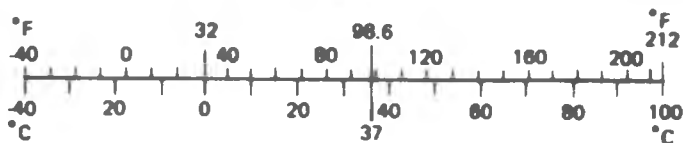

Fig. 0A-14 -- Metric Information, Chart D

## DECIMAL AND METRIC EQUIVALENTS

| Fractions | Decimal<br>In. | Metric<br>MM. | Fractions | Decimal<br>In. | Metric<br>MM. |
|-----------|----------------|---------------|-----------|----------------|---------------|
| 1/64      | .015625        | .39688        | 33/64     | .515625        | 13.09687      |
| 1/32      | .03125         | .79375        | 17/32     | .53125         | 13.49375      |
| 3/64      | .046875        | 1.19062       | 35/64     | .546875        | 13.89062      |
| 1/16      | .0625          | 1.58750       | 9/16      | .5625          | 14.28750      |
| 5/64      | .078125        | 1.98437       | 37/64     | .578125        | 14.68437      |
| 3/32      | .09375         | 2.38125       | 19/32     | .59375         | 15.08125      |
| 7/64      | .109375        | 2.77812       | 39/64     | .609375        | 15.47812      |
| 1/8       | .125           | 3.1750        | 5/8       | .625           | 15.87500      |
| 9/64      | .140625        | 3.57187       | 41/64     | .640625        | 16.27187      |
| 5/32      | .15625         | 3.96875       | 21/32     | .65625         | 16.66875      |
| 11/64     | .171875        | 4.36562       | 43/64     | .671875        | 17.06562      |
| 3/16      | .1875          | 4.76250       | 11/16     | .6875          | 17.46250      |
| 13/64     | .203125        | 5.15937       | 45/64     | .703125        | 17.85937      |
| 7/32      | .21875         | 5.55625       | 23/32     | .71875         | 18.25625      |
| 15/64     | .234375        | 5.95312       | 47/64     | .734375        | 18.65312      |
| 1/4       | .250           | 6.35000       | 3/4       | .750           | 19.05000      |
| 17/64     | .265625        | 6.74687       | 49/64     | .765625        | 19.44687      |
| 9/32      | .28125         | 7.14375       | 25/32     | .78125         | 19.84375      |
| 19/64     | .296875        | 7.54062       | 51/64     | .796875        | 20.24062      |
| 5/16      | .3125          | 7.93750       | 13/16     | .8125          | 20.63750      |
| 21/64     | .328125        | 8.33437       | 53/64     | .828125        | 21.03437      |
| 11/32     | .34375         | 8.73125       | 27/32     | .84375         | 21.43125      |
| 23/64     | .359375        | 9.12812       | 55/64     | .859375        | 21.82812      |
| 3/8       | .375           | 9.52500       | 7/8       | .875           | 22.22500      |
| 25/64     | .390625        | 9.92187       | 57/64     | .890625        | 22.62187      |
| 13/32     | .40625         | 10.31875      | 29/32     | .90625         | 23.01875      |
| 27/64     | .421875        | 10.71562      | 59/64     | .921875        | 23.41562      |
| 7/16      | .4375          | 11.11250      | 15/16     | .9375          | 23.81250      |
| 29/64     | .453125        | 11.50937      | 61/64     | .953125        | 24.20937      |
| 15/32     | .46875         | 11.90625      | 31/32     | .96875         | 24.60625      |
| 31/64     | .484375        | 12.30312      | 63/64     | .984375        | 25.00312      |
| 1/2       | .500           | 12.70000      | 1         | 1.00           | 25.40000      |

Fig. 0A-15 -- Metric Information, Chart E

**LIST OF AUTOMOTIVE ABBREVIATIONS  
WHICH MAY BE USED IN THIS MANUAL**

|   |  |   |
|---|--|---|
| <p>A - Ampere(s)<br/>                     A-6 - Axial 6 Cyl. A/C Compressor<br/>                     A/C - Air Conditioning<br/>                     ACC - Automatic Climate Control<br/>                     Adj. - Adjust<br/>                     A:F - Air/Fuel (As in Air/Fuel Ratio)<br/>                     AIR - Air Injection Reaction System<br/>                     ALC - Automatic Level Control<br/>                     ALCL - Assembly Line Communications Link<br/>                     Alt. - Altitude<br/>                     APT - Adjustable Part Throttle<br/>                     AT - Automatic Transmission<br/>                     ATC - Automatic Temperature Control<br/>                     ATDC - After Top Dead Center</p>   | <p>EFE - Early Fuel Evaporation<br/>                     EFI - Electronic Fuel Injection<br/>                     EGR - Exhaust Gas Recirculation<br/>                     ELC - Electronic Level Control<br/>                     EMF - Electromotive Force<br/>                     EMR - Electronic Module Retard<br/>                     EOS - Exhaust Oxygen Sensor<br/>                     ESC - Electronic Spark Control<br/>                     EST - Electronic Spark Timing<br/>                     ETC - Electronic Temperature Control<br/>                     ETCC - Electronic Touch Comfort Control<br/>                     ETR - Electronically Tuned Receiver<br/>                     Exh. - Exhaust</p> | <p>OHC - Overhead Cam<br/>                     OL - Open Loop<br/>                     OXY - Oxygen</p>   |
| <p>BARO - Barometric Absolute Pressure Sensor<br/>                     Bat. - Battery<br/>                     Bat. + - Positive Terminal<br/>                     Bbl. - Barrel<br/>                     BHP - Brake Horsepower<br/>                     BP - Back Pressure<br/>                     BTDC - Before Top Dead Center</p>   | <p>FMVSS - Federal Motor Vehicle Safety Standards<br/>                     Ft. Lb. - Foot Pounds (Torque)<br/>                     FWD - Front Wheel Drive<br/>                     - Four Wheel Drive<br/>                     4 x 4 - Four Wheel Drive</p>   | <p>PAIR - Pulse Air Injection Reaction System<br/>                     P/B - Power Brakes<br/>                     PCV - Positive Crankcase Ventilation<br/>                     PECV - Power Enrichment Control Valve<br/>                     P/N - Park, Neutral<br/>                     PROM - Programmable, Read Only Memory<br/>                     P/S - Power Steering<br/>                     PSI - Pounds Per Square Inch<br/>                     Pt. - Pint<br/>                     PTO - Power Takeoff</p>   |
| <p>Cat. Conv. - Catalytic Converter<br/>                     CC - Catalytic Converter<br/>                     - Cubic Centimeter<br/>                     - Converter Clutch<br/>                     CCC - Computer Command Control<br/>                     C-4 - Computer Controlled Catalytic Converter<br/>                     CB - Citizens Band (Radio)<br/>                     CCOT - Cycling Clutch (Orifice) Tube<br/>                     CCP - Controlled Canister Purge<br/>                     C.E. - Check Engine<br/>                     CEAB - Cold Engine Airbleed<br/>                     CEMF - Counter Electromotive Force<br/>                     CID - Cubic Inch Displacement<br/>                     CLOOP - Closed Loop<br/>                     CLCC - Closed Loop Carburetor Control<br/>                     CLTBI - Closed Loop Throttle Body Injection<br/>                     Conv. - Converter<br/>                     CP - Canister Purge<br/>                     Cu. In. - Cubic Inch<br/>                     CV - Constant Velocity<br/>                     Cyl. - Cylinder(s)</p> | <p>HD - Heavy Duty<br/>                     HEI - High Energy Ignition<br/>                     Hg. - Mercury<br/>                     Hi. Alt. - High Altitude<br/>                     HVAC - Heater-Vent-Air Conditioning<br/>                     HVACM - Heater-Vent-Air Conditioning Module<br/>                     HVM - Heater-Vent-Module</p>  | <p>Qt. - Quart</p> <p>R - Resistance<br/>                     R-4 - Radial Four Cyl. A/C Compressor<br/>                     RF - Right Front<br/>                     RPM - Revolutions Per Minute<br/>                     RR - Right Rear<br/>                     RTV - Room Temperature Vulcanizing (Sealer)<br/>                     RVR - Response Vacuum Reducer<br/>                     RWD - Rear Wheel Drive</p>  |
| <p>DBB - Dual Bed Bead<br/>                     DBM - Dual Bed Monolith<br/>                     DEFI - Digital Electronic Fuel Injection<br/>                     DFI - Digital Fuel Injection<br/>                     Diff. - Differential<br/>                     Distr. - Distributor</p>   | <p>IAC - Idle Air Control<br/>                     IC - Integrated Circuit<br/>                     ID - Identification<br/>                     - Inside Diameter<br/>                     ILC - Idle Load Compensator<br/>                     I/P - Instrument Panel<br/>                     ISC - Idle Speed Control</p>  | <p>SAE - Society of Automotive Engineers<br/>                     SI - System International<br/>                     Sol. - Solenoid</p>  |
| <p>EAC - Electric Air Control Valve<br/>                     EAS - Electric Air Switching Valve<br/>                     ECC - Electronic Comfort Control<br/>                     ECM - Electronic Control Module<br/>                     ECS - Emission Control System<br/>                     ECU - Engine Calibration Unit<br/>                     EEC - Evaporative Emission Control<br/>                     EEVIR - Evaporator Equalized Valves in Receiver</p>   | <p>km - Kilometers<br/>                     km/hr - Kilometers Per Hour<br/>                     KV - Kilovolts (Thousands of Volts)<br/>                     km/L - Kilometers/Liter (mpg)<br/>                     kPa - Kilopascals</p>   | <p>TAC - Thermostatic Air Cleaner<br/>                     TACH - Tachometer<br/>                     TBI - Throttle Body Injection<br/>                     TCC - Transmission Converter Clutch<br/>                     TCS - Transmission Controlled Spark<br/>                     TDC - Topdead Center<br/>                     TPS - Throttle Position Sensor<br/> <b>TURB</b> - Turbocharger<br/>                     T/V - Throttle Valve<br/>                     TVBV - Turbocharger Vacuum Bleed Valve<br/>                     TVRS - Television &amp; Radio Suppression<br/>                     TVS - Thermal Vacuum Switch</p> |
|   | <p>L - Liter<br/>                     L-4 - Four Cylinder In-Line (Engine)<br/>                     L-6 - Six Cylinder In-Line (Engine)<br/>                     LF - Left Front<br/>                     LR - Left Rear</p>   | <p>UJT - Universal Joint</p>  |
|   | <p>Man. Vac. - Manifold Vacuum<br/>                     MAP - Manifold Absolute Pressure<br/>                     MAT - Manifold Air Temperature Sensor<br/>                     M/C - Mixture Control<br/>                     MPG - Miles Per Gallon<br/>                     MPH - Miles Per Hour<br/>                     MT - Manual Transmission</p>   | <p>V - Volt(s)<br/>                     V-6 - Six Cylinder Engine - Arranged in a "V"<br/>                     V-8 - Eight Cylinder Engine - Arranged in a "V"<br/>                     Vac. - Vacuum<br/>                     VATS - Vehicle Anti-Theft System<br/>                     VIN - Vehicle Identification Number<br/>                     VIR - Valves in Receiver<br/>                     VSS - Vehicle Speed Sensor<br/>                     VMV - Vacuum Modulator Valve</p>  |
|   | <p>N m - Newton Metres (Torque)<br/>                     OD - Outside Diameter</p>   | <p>W/ - With<br/>                     W/B - Wheel Base<br/>                     W/O - Without<br/>                     WOT - Wide Open Throttle</p>   |
|   |  | <p>X-Valve - Expansion Valve</p>  |

Fig. 0A-16 -- Common Abbreviations

# SECTION 0B

# MAINTENANCE AND LUBRICATION

## CONTENTS

|   |       |
|---|-------|
| Gasoline Engine, L.D. Emissions, 49 States.....   | 0B-2  |
| Maintenance Schedule .....                        | 0B-2  |
| Scheduled Maintenance Service .....               | 0B-2  |
| Owner Inspections and Services.....               | 0B-4  |
| Recommended Fluids and Lubricants .....           | 0B-7  |
| Gasoline Engine, L.D. Emissions, California ..... | 0B-8  |
| Maintenance Schedule .....                        | 0B-8  |
| Scheduled Maintenance Services.....               | 0B-8  |
| Owner Inspections and Services.....               | 0B-10 |
| Recommended Fluids and Lubricants .....           | 0B-13 |
| Gasoline Engine, H.D.Emission .....               | 0B-14 |
| Maintenance Schedule .....                        | 0B-14 |
| Scheduled Maintenance Services.....               | 0B-14 |
| Owner Inspections and Services.....               | 0B-16 |
| Recommended Fluids and Lubricants .....           | 0B-20 |
| Diesel Engine .....                               | 0B-21 |
| Maintenance Schedule .....                        | 0B-21 |
| Scheduled Maintenance Services.....               | 0B-21 |
| Owner Inspections and Services.....               | 0B-22 |
| Recommended Fluids and Lubricants .....           | 0B-26 |



| ITEM NO. | TO BE SERVICED                                     | WHEN TO PERFORM<br>Months or Miles (kilometers) Whichever Occurs First  | The services shown in this schedule up to 45,000 miles (72 000 km) are to be performed after 45,000 miles at the same intervals. |                         |                         |                         |                         |                         |  |
|----------|--|---|--|-------------------------|-------------------------|-------------------------|-------------------------|-------------------------|--|
|          |  |   | 7,500 Mi.<br>12 000 km   | 15,000 Mi.<br>24 000 km | 22,500 Mi.<br>36 000 km | 30,000 Mi.<br>48 000 km | 37,500 Mi.<br>60 000 km | 45,000 Mi.<br>72 000 km |  |
| 1        | Chassis Lubrication                                | Lubricate every 12 Months or 7,500 Miles (12 000 km)  | ●  | ●                       | ●                       | ●                       | ●                       | ●                       |  |
| 2        | Engine Oil and Filter*                             | See Explanation for service intervals   |  |                         |                         |                         |                         |                         |  |
| 3        | Carburetor Choke and Hoses*                        | Check at 6 Months or 7,500 Miles (12 000 km), then at 30,000 Miles (48 000 km).                                 | ●  |                         |                         | ●                       |                         | ●                       |  |
| 4        | Carburetor or Throttle Body Mounting* <sup>2</sup> | Also check Item 3 at 45,000 Miles (72 000 km).  | ●  |                         |                         | ●                       |                         |                         |  |
| 5        | Engine Idle Speed (See Explanation)*               | Inspect every 12 Months or 15,000 Miles (24 000 km)   |  | ●                       |                         | ●                       |                         | ●                       |  |
| 6        | Vacuum or AIR Pump Drive Belts*                    | Every 24 Months or 30,000 Miles (48 000 km)   |  |                         |                         | ●                       |                         |                         |  |
| 7        | Cooling System Refill                              | Every 30,000 Miles (48 000 km)  |  |                         |                         | ●                       |                         |                         |  |
| 8        | Wheel Bearing Repack                               | See Explanation for service intervals   |  |                         |                         |                         |                         |                         |  |
| 9        | Transmission Fluid                                 | Check at 6 Months or 7,500 Miles (12 000 km), then at 30,000 Miles (48 000 km), and at 45,000 Miles (72 000 km) | ●  |                         |                         | ●                       |                         | ●                       |  |
| 10       | Vacuum Advance System*                             | Replace every 30,000 Miles (48 000 km)  |  |                         |                         | ●                       |                         |                         |  |
| 11       | Spark Plugs*                                       | See explanation for service intervals   |  |                         |                         |                         |                         |                         |  |
| 12       | PCV System Check and Service*                      | Service every 36 Months or 30,000 Miles (48 000 km)   |  |                         |                         | ●                       |                         |                         |  |
| 13       | EGR System*  | See Explanation for service intervals   |  |                         |                         |                         |                         |                         |  |
| 14       | Air Cleaner and PCV Filter*                        | Adjust every 30,000 Miles (48 000 km)   |  |                         |                         | ●                       |                         |                         |  |
| 15       | Engine Timing*                                     | Inspect every 15,000 Miles (24 000 km)  |  | ●                       |                         | ●                       |                         | ●                       |  |
| 16       | Spark Plug Wires and Distributor*                  | Inspect every 12 Months or 15,000 Miles (24 000 km)   |  | ●                       |                         | ●                       |                         | ●                       |  |
| 17       | Fuel Tank, Cap and Lines*                          | Check at 7,500 Miles (12 000 km) then at 30,000 Miles (48 000 km)   | ●  |                         |                         | ●                       |                         |                         |  |
| 18       | Early Fuel Evaporation System* <sup>2</sup>        | Check at 30,000 miles (48 000 km)   |  |                         |                         | ●                       |                         |                         |  |
| 19       | Evaporation Control System*                        | Service every 15,000 Miles (24 000 km)  |  | ●                       |                         | ●                       |                         | ●                       |  |
| 20       | Idle Stop Solenoid*                                |   |  |                         |                         | ●                       |                         |                         |  |
| 21       | Fuel Filter*                                       |   |  | ●                       |                         | ●                       |                         | ●                       |  |
| 22       | Valve Lash Adjustment* <sup>1</sup>                |   |  | ●                       |                         | ●                       |                         | ●                       |  |

Fig. OB-1--Maintenance Schedule, Gasoline, LD Emissions, 49 States

## GASOLINE ENGINE, L.D. EMISSION, 49 STATES

### NORMAL VEHICLE USE

The maintenance instructions contained in this section are based on the assumption that your vehicle will be used as designed:

- to carry passengers and cargo within the limitations indicated on the Tire Placard located on the edge of the driver's door.
- on reasonable road surfaces within legal operating limits.
- on a daily basis, as a general rule, for at least several miles (km), and
- on unleaded gasoline.

Unusual operating conditions will require more frequent vehicle maintenance as specified.

### EXPLANATION OF SCHEDULED MAINTENANCE SERVICES

#### Item 1 Chassis Lubrication

Every 12 months or 7,500 miles (12 000 km), lubricate transmission shift linkage, hood latch hood and door hinges, parking brake cable guides, underbody contact points and linkage, clutch linkage, propshaft, transfer case shift lever and clutch pedal springs. Lubricate clutch cross-shaft every 30,000 miles (48 000 km).

#### Item 2 Engine Oil and Oil Filter

Oil and filter change intervals depend upon how you use your vehicle. The information in Figs. OB-2 and OB-3 should assist in determining the proper oil and filter change intervals for you:

#### Item 3 Carburetor Choke and Hoses

Verify that choke and vacuum break work properly and are within specifications. Correct any binding caused by damage or gum on the choke shaft. Inspect hoses for proper hookup, cracks, rubbing, or decay. Correct as necessary.

#### Item 4 Carburetor Mounting Torque

Check torque of mounting bolts and/or nuts.

#### Item 5 Engine Idle Speed Adjustment

Adjust to the specifications shown on the underhood label. You must use calibrated test equipment.

#### Item 6 Vacuum or AIR Pump Drive Belts

Inspect belts driving the vacuum or AIR pump. Look for cracks, fraying, wear and proper tension. Adjust or replace as needed.

#### Item 7 Cooling System

Drain, flush and refill system with new coolant as shown in your Owner's Manual.

| TYPE OF USE   | CHANGE INTERVAL  |
|---|--|
| Operating in dusty areas.   | Change engine oil and filter every 3,000 miles (4800 km) or 3 months, whichever comes first  |
| Towing a trailer.   |  |
| Idling for extended periods and/or low speed operation such as found in police, taxi or door-to-door delivery.  |  |
| Operating when outside temperatures remain below freezing and when most trips are less than 4 miles (6 km).   | Change engine oil every 7,500 miles (12000 km) or 12 months, whichever comes first.<br><br>Change engine oil filter at first oil change, then every other oil change if mileage determines when you change oil. If time determines change intervals, change the filter with each oil change. |
| Operating on a daily basis, as a general rule, for several miles and when none of the above conditions apply.   |  |
| Always change oil and filter as soon as possible after driving in a dust storm. ALSO, ALWAYS USE SF-QUALITY OILS OF THE PROPER VISCOSITY. See Owner's Manual for further details. |  |

Fig. 0B-2--Oil Change Interval Chart, Gasoline, LDX, 49 States

**Item 8 Wheel Bearing Repack**

**SEVERE SERVICE (USES SUCH AS TAXI, POLICE OR DELIVERY SERVICE)** Clean and repack front wheel bearings at each brake relining or 15,000 miles (24 000 km), whichever comes first.

**NORMAL SERVICE** Clean and repack front wheel bearings at each brake relining or 30,000 miles (48 000 km), whichever comes first.

Be sure to use lubricant as specified in Fig. 0B-7.

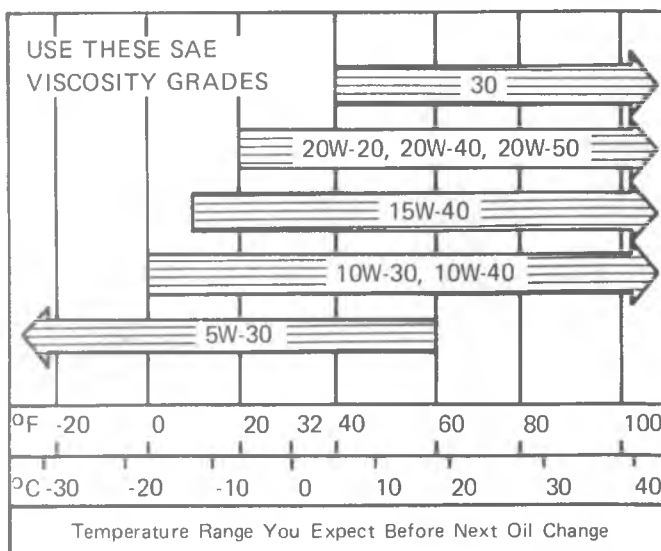

Fig. 0B-3--Oil Viscosity Chart, Gasoline, LDX, 49 States

**Item 9 Transmission Fluid**

**Automatic Transmission** - Change the transmission fluid and change the filter (or service the screen) every 15,000 miles (24 000 km) if the vehicle is mainly driven under one or more of these hot conditions:

- In heavy city traffic where the outside temperature regularly reaches 90°F (32°C).
- In hill or mountain areas.
- Frequent trailer pulling.
- Uses such as taxi, police or delivery service.

If vehicle is not used under any of these conditions, change the fluid and filter (or service the screen) every 100,000 miles (160 000 km).

See Owner's Manual for further details.

**Item 10 Vacuum Advance System and Hoses**

Check system for proper operation. Check hoses for proper hookup, cracks, rubbing or decay. Replace parts as needed.

**Item 11 Spark Plug Replacement**

Replace with the type listed in your Owner's Manual.

**Item 12 PCV Valve Inspection**

Check that system works properly each 15,000 miles (24 000 km).

Replace the valve and any worn, plugged or collapsed hoses at 30,000 miles (48 000 km).

**Item 13 Exhaust Gas Recirculation System (EGR)**

Conduct EGR operation system check as covered later in this manual. Replace or clean parts as required.

**Item 14 Air Cleaner and PCV Filter**

Replace every 30,000 miles (48 000 km). Replace more often under dusty conditions. Ask your dealer for the proper replacement intervals for your driving conditions.

**Item 15 Engine Timing Check**

Adjust timing to underhood label specifications.

**Item 16 Spark Plug Wires and Distributor Inspection**

Clean wires. Inspect for burns, cracks or other damage. Check the boot fit at distributor cap and spark plugs. Inspect inside and outside of the cap and rotor for cracks, carbon tracking and corrosion. Replace as needed.

**Item 17 Fuel Tank, Cap and Lines**

Inspect the fuel tank, cap and lines for damage or leaks. Remove cap, inspect gasket for an even filler neck imprint, and any damage. Replace parts as needed.

**Item 18 Early Fuel Evaporation (EFE) System**

Check that valve works properly; correct any binding. Check that thermal vacuum switch works properly. Check hoses for cracks, rubbing or decay. Replace parts as needed.

**Item 19 Evaporation Control System (ECS)**

Check all fuel and vapor lines and hoses for proper hookup, routing and condition. Check that bowl vent and purge valves work properly, if equipped. Remove canister, check for cracks or damage. Replace as needed.

**Item 20 Idle Stop Solenoid, and/or Dashpot**

Check that parts work properly. Replace them as needed.

**Item 21 Fuel Filter**

Replace carburetor fuel filter at mileage shown on Maintenance Schedule or sooner if clogged.

**Item 22 Valve Lash Adjustment**

Incorrect valve clearance will result in increased engine

noise and lower engine output, thereby adversely affecting engine performance. Retorque rocker shaft bracket nuts before checking and adjusting valve clearance. Check and adjust valve clearance every 15,000 miles (24 000 km).

**OWNER INSPECTIONS AND SERVICES**

Listed in Figs. 0B-4 through 0B-6 are vehicle inspections and services which should be made by either you or a qualified technician at the frequencies indicated to help ensure proper safety emission performance and dependability of your vehicle. Take any problems promptly to your dealer or a qualified technician for service advice. Whenever repairs are necessary, have them completed at once. For your safety and that of others, any safety related components that could have been damaged in an accident should be inspected. All needed repairs should be performed before operating your vehicle.

| FREQUENCY                            | INSPECTION OR SERVICE                            | WHAT TO DO  |
|--------------------------------------|--|---|
| <b>BEFORE OPERATING YOUR VEHICLE</b> | Warning light, buzzer tone and chime operation.  | Check operation of all warning lights, buzzers, tone generators and chimes — also all interior lights. See your Owner's Manual for details.   |
|                                      | Glass condition                                  | Look for broken, scratched or damaged glass that could reduce vision or cause injury. Replace or repair promptly.   |
|                                      | Seat adjuster operation                          | When adjusting a manual seat, be sure seat adjusters latch by pushing seat forward and backward   |
|                                      | Rearview mirror and sun visor operation          | Make sure friction joints hold mirrors and sun visors in place.   |
|                                      | Door and gate latch operation                    | Make sure that all doors and wagon or hatchback gates close, latch and lock tightly   |
| <b>WHILE OPERATING YOUR VEHICLE</b>  | Automatic transmission shift indicator operation | Make sure the indicator points to the gear chosen.  |
|                                      | Windshield wiper and washer operation            | Note the operation and condition of the wiper blades and the flow and aim of the washer spray.  |
|                                      | Defroster operation                              | Periodically check the air flow from the ducts at the inside base of the windshield. Do this with the heater control lever in "defrost" position and fan lever in "high".   |
|                                      | Horn operation                                   | Blow horn occasionally to make sure it works. Check all button locations.   |
|                                      | Brake system operation                           | Be alert to strange sounds, increased brake pedal travel or repeated pulling to one side when braking. Also, if the brake warning light goes on, something may be wrong. See your Owner's Manual.   |
|                                      | Exhaust system operation                         | Be alert to any changes in the sound of the system or any smell of fumes. These are signs the system may be leaking or overheating. Have it inspected and repaired at once. Also see "Engine Exhaust Gas Caution (Carbon Monoxide)" and "Catalytic Converter" in your Owner's Manual. |
|                                      | Tires, Wheels and Alignment                      | Be alert to a vibration of the steering wheel or seat at normal highway speeds. This may mean a wheel balance is needed. Also, a pull right or left on a straight, level road may show the need for a tire pressure adjustment or wheel alignment.                                    |
|                                      | Steering system operation                        | Be alert to changes in steering action. An inspection is needed when the steering wheel is harder to turn, or has too much free play, or if strange sounds are noted when turning or parking.   |
|                                      | Headlight aim                                    | Take note of light pattern occasionally. If beams seem improperly aimed, headlights should be adjusted.   |
| <b>AT EACH FUEL FILL</b>             | Engine oil level†                                | Check level and add if necessary. See Owner's Manual. Section 5.  |
|                                      | Engine coolant level and condition‡              | Check level in coolant recovery tank and add if necessary. Inspect coolant and replace if dirty or rusty. See Owner's Manual. Section 5.  |
|                                      | Windshield washer fluid level                    | Check level in reservoir and add if necessary.  |
|                                      | Hood latch operation                             | When opening hood, note the operation of secondary latch. It should keep hood from opening all the way when primary latch is released. Make sure that hood closes firmly after services are performed.  |

Fig. 0B-4—Owner Inspections and Services, Chart A

| FREQUENCY   | INSPECTION OR SERVICE                                     | WHAT TO DO   |
|---|---|--|
| AT LEAST MONTHLY  | Tire pressure check                                       | Maintain pressures as shown on Tire Placard on the driver's door (include spare). Pressure should be checked when tires are 'cold'   |
|   | Light operation   | Check operation of license plate light, sidemarker lights, headlights, parking lights, taillights, brake lights, turn signals, backup lamps and hazard warning flashers.   |
|   | Fluid leak check  | Periodically, after the vehicle has been parked for a while, inspect the surface beneath the vehicle for water, oil, fuel or other fluids. Water dripping from the air conditioning system after use is normal. If you notice fuel leaks or fumes, the cause should be found and corrected at once.  |
| AT LEAST SEMI-ANNUALLY (FOR EXAMPLE, EVERY SPRING AND FALL) | Automatic transmission fluid level                        | Maintain level within operating range on dipstick. Refer to Owner's Manual Section 5.  |
|   | Power steering pump reservoir level                       | Check level in accordance with Owner's Manual instructions (Section 5) and keep at proper level.   |
|   | Brake master cylinder reservoir level                     | Check fluid level. Note: A low fluid level can indicate worn disc brake pads and should be checked.  |
|   | Clutch Pedal free travel                                  | Note the clutch pedal free travel. It should be about 1". Adjust linkage whenever there is little or no free travel.   |
| AT LEAST ANNUALLY   | Parking brake and transmission "Park" mechanism operation | Park on a fairly steep hill and hold the vehicle with the parking brake only. This checks holding ability. For automatic transmission, check "Park" by releasing all brakes after shifting the transmission to "P" (Park).   |
|   | Starter safety switch operation                           | <b>Caution:</b> Before performing the following safety switch check, be sure to have enough room around the vehicle. Then, firmly apply both the parking brake (see Owner's Manual for procedure) and the regular brakes. Do not use the accelerator pedal. If the engine starts, be ready to turn off the ignition promptly. Take these precautions because the vehicle could move without warning and possibly cause personal injury or property damage. |
|   |   | On automatic transmission vehicles, try to start the engine in each gear. The starter should crank only in "P" (Park) or "N" (Neutral).  |
|   |   | On manual transmission vehicles place the shift lever in "Neutral" push the clutch halfway and try to start. The starter should crank only when the clutch is fully depressed.   |
|   | Seatback latch operation                                  | Be sure seatbacks latch on those vehicles with folding seats using mechanical latches. See Owner's Manual for inertial latch operating information.  |
|   | Lap and shoulder belts condition and operation            | Inspect belt system, including webbing, buckles, latch plates, retractors, guide loops and anchors.  |
|   | Movable head restraint operation                          | On vehicles with movable restraints, make sure restraints stay in the desired position. (See adjustment instructions in Owner's Manual.)   |
|   | Seatback recliner operation (if equipped)                 | Make sure the recliner is holding by pushing and pulling on the top of the seatback while it is reclined.  |
|   | Spare tire and jack storage                               | Be alert to rattles in rear of vehicle. Make sure the spare tire, all jacking equipment and any covers or doors are securely stowed at all times. Oil jack ratchet mechanism after each use.   |
|   | Underbody flushing  | At least every spring, flush from the underbody with plain water any corrosive materials used for ice and snow removal and dust control. Take care to thoroughly clean any areas where mud and other debris can collect. Sediment packed in closed areas of the vehicle should be loosened before being flushed.   |
|   | Steering column lock operation                            | While parked, try to turn key to "Lock" in each gear range. The key should turn to "Lock" only when gear is in "Park" on automatic or "Reverse" on manual transmission. On vehicles with key release lever, try to turn key to "Lock" without depressing the lever. The key should turn to "Lock" only with the key lever depressed. On all vehicles, the key should come out only in "Lock".  |
|   | Thermostatically controlled air cleaner*                  | Inspect all hoses and ducts for proper hookup. Be sure valve works properly.   |

Fig. 0B-5--Owner Inspections and Services, Chart B

| FREQUENCY  | INSPECTION OR SERVICE                  | WHAT TO DO   |
|--|--|--|
| <b>EACH TIME OIL IS CHANGED (WHEN VEHICLE IS ON HOIST)</b> | Tire and wheel inspection and rotation | Check tires for uneven or abnormal wear. Check for damaged wheels. To equalize wear and obtain maximum tire life, it is suggested that tires be rotated at about 7,500 miles (12 000 km) then each 15,000 miles (24 000 km) thereafter. See "Tires" in Owner's Manual. Section 5, for further information.   |
|  | Brake systems inspection               | For convenience the following should be done when wheels are removed for rotation: Inspect lines and hoses for proper hookup, binding, leaks, cracks, chafing etc. Inspect disc brake pads for wear and rotors for surface condition. Also inspect drum brake linings for wear and cracks. Inspect other brake parts, including drums, wheel cylinders, parking brake, etc. at the same time. Check parking brake adjustment.<br><b>INSPECT BRAKES MORE OFTEN IF HABIT OR CONDITIONS RESULT IN FREQUENT BRAKING.</b>   |
|  | Steering and suspension                | Inspect front and rear suspension and steering system for damaged, loose or missing parts, signs of wear or lack of lubrication. Inspect power steering lines and hoses for proper hookup, binding, leaks, cracks, chafing, etc. (On vehicles equipped with manual steering gear, check for seal leakage.) Inspect final drive axle output shaft seals for leaking.<br>● Front Suspension and Steering Linkage<br>(a) On C20 and G30, lubricate every 4 months or 6,000 miles (9 000 km).<br>(b) On all other vehicles, lubricate every 12 months or 7,500 miles (12 000 km).<br>(c) Lubricate suspension and steering linkage every 3 months or 3,000 miles (4 800 km) when operating under dusty or muddy conditions and in extensive off-road use.  |
|  | Exhaust system inspection*             | Inspect complete system including catalytic converter. Inspect body near the exhaust system. Look for broken, damaged, missing or out-of-position parts as well as open seams, holes, loose connections or other conditions which could cause a heat build up in the floor pan or could let exhaust fumes seep into the trunk or passenger compartment.  |
|  | Throttle linkage inspection            | Inspect for damaged or missing parts, interference or binding.   |
|  | Engine drive belts                     | Inspect all belts for cracks, fraying wear and proper tension. Adjust or replace as needed   |
|  | Engine cooling system*                 | Inspect coolant and freeze protection. If dirty or rusty, drain, flush and refill with new coolant as shown in your Owner's Manual. Keep coolant at the proper mixture as specified in your Owner's Manual. This provides proper freeze protection, corrosion inhibitor level and engine operating temperature. Inspect hoses and replace if cracked, swollen or rotted. Tighten hose clamps. Clean outside of radiator and air conditioning condenser. Wash radiator filler cap and neck. To help ensure proper operation, a pressure test of both the cooling system and cap is also recommended.  |
|  | Rear axle/front axle/transfer case     | Check fluid level and add if needed.<br>● Locking Differential - In general service, drain fluid at 7,500 miles (12 000 km) and refill. Check fluid level and add as needed at subsequent 7,500 mile (12 000 km) intervals. In severe operating conditions, or trailer towing applications, drain fluid every 7,500 miles, (12 000 km) and refill<br>● Standard Differential - In general service, check fluid level and add as needed every 7,500 miles (12 000 km). In severe operating conditions, trailer towing applications, drain fluid every 7,500 miles (12 000 km) and refill.<br>● Four Wheel Drive - Every 12 months or 7,500 miles (12 000 km), check front axle and transfer case and add lubricant when necessary. Lubricate propeller shaft slip joint, constant velocity universal joint and steering linkage. Oil control lever pivot point and exposed control linkage. Check vent hose at front axle transfer case for kinks and proper installation. More frequent lubrication may be required on heavy duty off-road operation. See Owner's and Driver's Manual for further information. |
|  | Manual transmission                    | Check fluid level and add as required.   |

Fig. OB-6--Owner Inspections and Services, Chart C

| USAGE  | FLUID/LUBRICANT  |
|--|--|
| Engine   | "SF" or "SF/CD" or "SF/CC" Engine Oil conforming to GM spec. 6048-M  |
| Engine Coolant   | Mixture of water and a high quality Ethylene Glycol base type antifreeze conforming to GM spec. 1825-M (GM Part No. 1052753) or equivalent |
| Brake System   | Delco Supreme 11 fluid or DOT-3  |
| Parking Brake Cables   | Chassis grease meeting requirements of GM spec. 6031-M   |
| Power Steering System  | GM power steering fluid Part No. 1050017 or equivalent   |
| Manual Steering Gear   | Lubricant GM Part No. 1051052 or equivalent  |
| Automatic Transmission<br>4-Speed Manual Trans. w/O.D.<br>S10 Truck with Manual Trans.<br>Transfer Case  | DEXRON® II Automatic Transmission Fluid  |
| Differential—Standard<br>Manual Transmission<br>(Except: 4-Speed with O.D., and<br>S10 Truck)  | SAE-80W, GL-5 or SAE-80W-90 GL-5 gear lubricant (SAE-80W—GL-5 in Canada)   |
| Differential—Locking   | Lubricant GM Part No. 1052271  |
| Manual Transmission Shift Linkage,<br>Column Shift, Propeller Shaft Slip<br>Joint  | Chassis grease meeting requirements of GM spec. 6031-M   |
| Key Lock Cylinders   | WD-40 Spray Lubricant or equivalent  |
| Clutch Linkage (Man. Trans. only)<br>a. Pivot points<br>b. Push rod to clutch fork joint, and<br>cross shaft pressure fitting  | a. Engine oil<br>b. Chassis grease meeting requirements of GM spec. 6031-M   |
| Chassis Lubrication  | Chassis grease meeting requirements of GM spec. 6031-M   |
| Windshield Washer Solvent  | GM Optikleen washer solvent Part No. 1051515 or equivalent   |
| Hood Latch Assembly<br>a. Pivots and spring anchor<br>b. Release pawl  | a. Engine oil<br>b. Chassis grease   |
| Front Wheel Bearings   | Lubricant GM Part No. 1051344 (one pound) or equivalent*   |
| Constant Velocity<br>Universal Joint   | GM Lubricant Part No. 1052497 or equivalent  |
| Automatic Transmission Shift<br>Linkage, Floor Shift Linkage, Hood<br>and Door hinges, body door hinge pins,<br>tailgate hinge and linkage, folding seat,<br>fuel door hinge | Engine Oil   |

\* Fluids and lubricants identified with GM part numbers or GM specification numbers may be obtained from your GM dealer.

Fig. 0B-7--Recommended Fluids and Lubricants

| ITEM NO. | TO BE SERVICED                                     | WHEN TO PERFORM<br>Months or Miles (kilometers) Whichever Occurs First         | The services shown in this schedule up to 45,000 miles (72 000 km) are to be performed after 45,000 miles at the same intervals. |                         |                         |                         |                         |                         |
|----------|--|--|--|-------------------------|-------------------------|-------------------------|-------------------------|-------------------------|
|          |  |  | 7,500 Mi.<br>12 000 km   | 15,000 Mi.<br>24 000 km | 22,500 Mi.<br>36 000 km | 30,000 Mi.<br>48 000 km | 37,500 Mi.<br>60 000 km | 45,000 Mi.<br>72 000 km |
| 1        | Chassis Lubrication                                | Lubricate every 12 Months or 7,500 Miles (12 000 km)                           | ●  | ●                       | ●                       | ●                       | ●                       | ●                       |
| 2        | Engine Oil and Filter*                             | See Explanation for service intervals  |  |                         |                         |                         |                         |                         |
| 3        | Carburetor Choke and Hoses*                        | Check at 6 Months or 7,500 Miles (12 000 km), then at 30,000 Miles (48 000 km) | ●  |                         |                         | ● <sup>2</sup>          |                         | ●                       |
| 4        | Carburetor or Throttle Body Mounting* <sup>4</sup> | Also check Item 3 at 45,000 Miles (72 000 km).                                 | ● <sup>1</sup>   |                         |                         | ●                       |                         |                         |
| 5        | Engine Idle Speed (See Explanation)*               | Inspect every 12 Months or 15,000 Miles (24 000 km)                            |  | ● <sup>1</sup>          |                         | ●                       |                         | ● <sup>1</sup>          |
| 6        | AIR Pump Drive Belts*                              | Every 24 Months or 30,000 Miles (48 000 km)                                    |  |                         |                         | ●                       |                         |                         |
| 7        | Wheel Bearing Repack                               | See Explanation for service intervals  |  |                         |                         | ●                       |                         |                         |
| 8        | Transmission Fluid                                 | Check every 30,000 Miles (48 000 km)   |  |                         |                         | ●                       |                         |                         |
| 9        | Vacuum Advance System*                             | Replace every 30,000 Miles (48 000 km)   |  |                         |                         | ● <sup>2</sup>          |                         |                         |
| 10       | Spark Plugs*                                       | See explanation for service intervals  |  |                         |                         | ●                       |                         |                         |
| 11       | PCV System Check and Service*                      | Service every 36 Months or 30,000 Miles (48 000 km)                            |  |                         |                         | ●                       |                         |                         |
| 12       | EGR System*  | See Explanation for service intervals  |  |                         |                         | ● <sup>2</sup>          |                         |                         |
| 13       | Air Cleaner and PCV Filter*                        | Adjust every 30,000 Miles (48 000 km)  |  |                         |                         | ●                       |                         |                         |
| 14       | Engine Timing*                                     | Inspect every 30,000 Miles (48 000 km)   |  |                         |                         | ●                       |                         |                         |
| 15       | Spark Plug Wires and Distributor*                  | Inspect every 12 Months or 15,000 Miles (24 000 km)                            |  | ●                       |                         | ●                       |                         | ●                       |
| 16       | Fuel Tank, Cap and Lines*                          | Check at 7,500 Miles (12 000 km) then at 30,000 Miles (48 000 km)              | ●  |                         |                         | ●                       |                         |                         |
| 17       | Early Fuel Evaporation System* <sup>4</sup>        | Check at 30,000 Miles (48 000 km)  |  |                         |                         | ●                       |                         |                         |
| 18       | Idle Stop Solenoid*                                | Adjust every 15,000 Miles (24 000 km)  |  | ●                       |                         | ●                       |                         | ● <sup>2</sup>          |
| 19       | Valve Lash Adjustment* <sup>1</sup>                |  |  |                         |                         |                         |                         |                         |

\*Also an Emission Control Service

<sup>2</sup> Only applicable to 1.9L engine - Engine Family D1G1 9T2BA7

<sup>4</sup> A separately driven air pump belt check is recommended but not required at 15,000 Miles (24 000 km) and 45,000 Miles (72 000 km)

<sup>1</sup> Not applicable to 1.9L engine - Engine Family D1G1 9T2BA7

Fig. 0B-11--Maintenance Schedule, Gasoline, LDX, California

## GASOLINE ENGINE, L.D. EMISSION, CALIFORNIA

### NORMAL VEHICLE USE

The maintenance instructions contained in this section are based on the assumption that your vehicle will be used as designed:

- to carry passengers and cargo within the limitation indicated on the Tire Placard located on the edge of the driver's door,
- on reasonable road surfaces within legal operating limits,
- on a daily basis, as a general rule, for at least several miles (km), and
- on unleaded gasoline.

Unusual operating conditions will require more frequent vehicle maintenance as specified.

### EXPLANATION OF SCHEDULED MAINTENANCE SERVICES

#### Item 1 Chassis Lubrication

Every 12 months or 7,500 miles (12 000 km) lubricate transmission shift linkage, hood latch, hood and door hinges, parking brake cable guides, underbody contact points and linkage, clutch linkage, propshaft transfer case shift lever and clutch pedal springs. Lubricate clutch cross-shaft every 30,000 miles (48 000 km).

#### Item 2 Engine Oil and Oil Filter

Oil and filter change intervals depend upon how you use your vehicle. The information in Figs. 0B-12 and 0B-13 should assist in determining the proper oil and filter change intervals for you.

#### Item 3 Carburetor Choke and Hoses

Verify that choke and vacuum break work properly and are within specifications. Correct any binding caused by damage or gum on the choke shaft. Inspect hoses for proper hookup, cracks, rubbing or decay. Correct as necessary.

#### Item 4 Carburetor Mounting Torque

Check torque of mounting bolts and/or nuts.

#### Item 5 Engine Idle Speed Adjustment

Adjust to the specifications shown on the underhood label. You must use calibrated test equipment.

#### Item 6 AIR Pump Drive Belts

Inspect belts driving the AIR pump. Look for cracks, fraying, wear and proper tension. Adjust or replace as needed.

#### Item 7 Cooling System

Drain, flush and refill system with new coolant as shown in your Owner's Manual.



| TYPE OF USE   | CHANGE INTERVAL  |
|---|--|
| Operating in dusty areas.   | Change engine oil and filter every 3,000 miles (4800 km) or 3 months, whichever comes first  |
| Towing a trailer.   |  |
| Idling for extended periods and/or low speed operation such as found in police, taxi or door-to-door delivery.  |  |
| Operating when outside temperatures remain below freezing and when most trips are less than 4 miles (6 km).   |  |
| Operating on a daily basis, as a general rule, for several miles and when none of the above conditions apply.   | Change engine oil every 7,500 miles (12000 km) or 12 months, whichever comes first.<br><br>Change engine oil filter at first oil change, then every other oil change if mileage determines when you change oil. If time determines change intervals, change the filter with each oil change. |
| Always change oil and filter as soon as possible after driving in a dust storm. ALSO, ALWAYS USE SF-QUALITY OILS OF THE PROPER VISCOSITY. See Owner's Manual for further details. |  |

Fig. 0B-12--Engine Oil Interval Chart, Gasoline, LDX, California

**Item 8 Wheel Bearing Repack**

**SEVERE SERVICE (USES SUCH AS TAXI, POLICE OR DELIVERY SERVICE)** - Clean and repack front wheel bearings at each brake relining or 15,000 miles (24 000 km), whichever comes first.

**NORMAL SERVICE** - Clean and repack front wheel bearings at each brake relining or 30,000 miles (48 000 km), whichever comes first.

Be sure to use lubricant as specified in Fig. 0B-17.

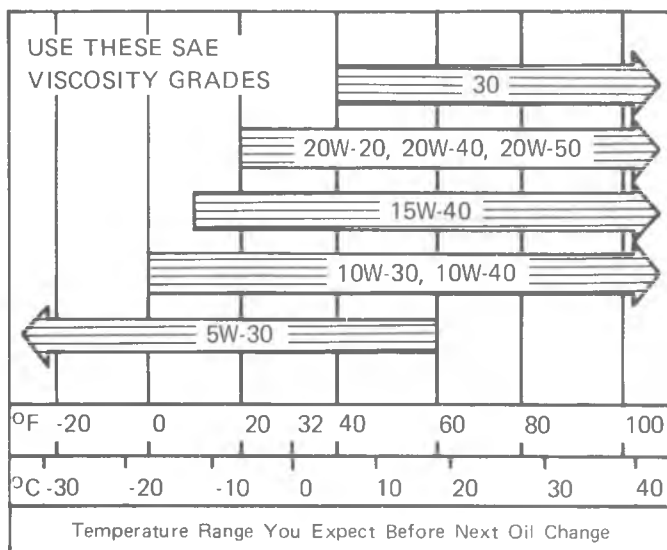

Fig. 0B-13--Oil Viscosity Chart, Gasoline, LDX, California

**Item 9 Transmission Fluid**

**Automatic Transmission** - Change the transmission fluid and change the filter (or service the screen) every 15,000 miles (24 000 km) if the vehicle is mainly driven under one or more of these hot conditions:

- In heavy city traffic where the outside temperature regularly reaches 90°F (32°C).
- In hill or mountain areas.
- Frequent trailer pulling.
- Uses such as taxi, police or delivery service.

If vehicle is not used under any of these conditions, change the fluid and filter (or service the screen) every 100,000 miles (160 000 km).

See Owner's Manual for further details.

**Item 10 Vacuum Advance System and Hoses**

Check system for proper operation. Check hoses for proper hookup, cracks, rubbing or decay. Replace parts as needed.

**Item 11 Spark Plug Replacement**

Replace with the type listed in your Owner's Manual.

**Item 12 PCV Valve Inspection**

Check that system works properly each 15,000 miles (24 000 km).

Replace the valve and any worn, plugged or collapsed hoses at 30,000 miles (48 000 km).

**Item 13 Exhaust Gas Recirculation System (EGR)**

Conduct EGR operation system check as covered later in this manual. Replace or clean parts as required.

**Item 14 Air Cleaner and PCV Filter**

Replace every 30,000 miles (48 000 km). Replace more often under dusty conditions. Ask your dealer for the proper replacement intervals for your driving conditions.

**Item 15 Engine Timing Check**

Adjust timing to underhood label specifications.

**Item 16 Spark Plug Wires and Distributor Inspection**

Clean wires. Inspect for burns, cracks or other damage. Check the boot fit at distributor cap and spark plugs. Inspect inside and outside of the cap and rotor for cracks, carbon tracking and corrosion. Replace as needed.

**Item 17 Fuel Tank, Cap and Lines**

Inspect the fuel tank, cap and lines for damage or leaks. Remove fuel cap, inspect gasket for an even filler neck imprint, and any damage. Replace parts as needed.

**Item 18 Early Fuel Evaporation (EFE) System**

Check that valve works properly; correct any binding. Check that thermal vacuum switch works, properly. Check hoses for cracks, rubbing or decay. Replace parts as needed.

**Item 19 Idle Stop Solenoid, and/or Dashpot**

Check that parts work properly. Replace them as needed.

**Item 20 Valve Lash Adjustment**

Incorrect valve clearance will result in increased engine noise and lower engine output, thereby adversely affecting engine performance. Replace rocker shaft bracket nuts before checking and adjusting valve clearance. Check and adjust valve clearance every 15,000 miles (24 000 km).

**OWNER INSPECTIONS AND SERVICES**

Listed below are vehicle inspections and services which should be made by either you or a qualified technician at the frequencies indicated to help ensure proper safety, emission performance and dependability of your vehicle. Take any problems promptly to your dealer or a qualified technician for service advice. Whenever repairs are necessary, have them completed at once. For your safety and that of others, any safety related components that could have been damaged in an accident should be inspected. All needed repairs should be performed before operating your vehicle.

| FREQUENCY                            | INSPECTION OR SERVICE                            | WHAT TO DO  |
|--------------------------------------|--|---|
| <b>BEFORE OPERATING YOUR VEHICLE</b> | Warning light, buzzer tone and chime operation   | Check operation of all warning lights, buzzers, tone generators and chimes — also all interior lights. See your Owner's Manual for details.   |
|                                      | Glass condition                                  | Look for broken, scratched or damaged glass that could reduce vision or cause injury. Replace or repair promptly.   |
|                                      | Seat adjuster operation                          | When adjusting a manual seat, be sure seat adjusters latch by pushing seat forward and backward.  |
|                                      | Rearview mirror and sun visor operation          | Make sure friction joints hold mirrors and sun visors in place.   |
|                                      | Door and gate latch operation                    | Make sure that all doors and wagon or hatchback gates close, latch and lock tightly.  |
| <b>WHILE OPERATING YOUR VEHICLE</b>  | Automatic transmission shift indicator operation | Make sure the indicator points to the gear chosen.  |
|                                      | Windshield wiper and washer operation            | Note the operation and condition of the wiper blades and the flow and aim of the washer spray.  |
|                                      | Defroster operation                              | Periodically check the air flow from the ducts at the inside base of the windshield. Do this with the heater control lever in "defrost" position and fan lever in "high".   |
|                                      | Horn operation                                   | Blow horn occasionally to make sure it works. Check all button locations.   |
|                                      | Brake system operation                           | Be alert to strange sounds, increased brake pedal travel or repeated pulling to one side when braking. Also, if the brake warning light goes on, something may be wrong. See your Owner's Manual.   |
|                                      | Exhaust system operation                         | Be alert to any changes in the sound of the system or any smell of fumes. These are signs the system may be leaking or overheating. Have it inspected and repaired at once. Also see "Engine Exhaust Gas Caution (Carbon Monoxide)" and "Catalytic Converter" in your Owner's Manual. |
|                                      | Tires, Wheels and Alignment                      | Be alert to a vibration of the steering wheel or seat at normal highway speeds. This may mean a wheel balance is needed. Also, a pull right or left on a straight, level road may show the need for a tire pressure adjustment or wheel alignment.                                    |
|                                      | Steering system operation                        | Be alert to changes in steering action. An inspection is needed when the steering wheel is harder to turn, or has too much free play, or if strange sounds are noted when turning or parking.   |
|                                      | Headlight aim                                    | Take note of light pattern occasionally. If beams seem improperly aimed, headlights should be adjusted.   |
| <b>AT EACH FUEL FILL</b>             | Engine oil level†                                | Check level and add if necessary. See Owner's Manual, Section 5.  |
|                                      | Engine coolant level and condition‡              | Check level in coolant recovery tank and add if necessary. Inspect coolant and replace if dirty or rusty. See Owner's Manual, Section 5.  |
|                                      | Windshield washer fluid level                    | Check level in reservoir and add if necessary.  |
|                                      | Hood latch operation                             | When opening hood, note the operation of secondary latch. It should keep hood from opening all the way when primary latch is released. Make sure that hood closes firmly after services are performed.  |

Fig. OB-14--Owner Inspections and Services, Chart A

| FREQUENCY   | INSPECTION OR SERVICE                                     | WHAT TO DO   |
|---|---|--|
| AT LEAST MONTHLY  | Tire pressure check                                       | Maintain pressures as shown on Tire Placard on the driver's door (include spare). Pressure should be checked when tires are cold.  |
|   | Light operation   | Check operation of license plate light, sidemarkers, headlights, parking lights, taillights, brake lights, turn signals, backup lamps and hazard warning flashers.   |
|   | Fluid leak check  | Periodically, after the vehicle has been parked for a while, inspect the surface beneath the vehicle for water, oil, fuel or other fluids. Water dripping from the air conditioning system after use is normal. If you notice fuel leaks or fumes, the cause should be found and corrected at once.  |
| AT LEAST SEMI-ANNUALLY (FOR EXAMPLE, EVERY SPRING AND FALL) | Automatic transmission fluid level                        | Maintain level within operating range on dipstick. Refer to Owner's Manual, Section 5.   |
|   | Power steering pump reservoir level                       | Check level in accordance with Owner's Manual instructions (Section 5) and keep at proper level.   |
|   | Brake master cylinder reservoir level                     | Check fluid level. Note: A low fluid level can indicate worn disc brake pads and should be checked.  |
|   | Clutch Pedal free travel                                  | Note the clutch pedal free travel. It should be about 1". Adjust linkage whenever there is little or no free travel.   |
| AT LEAST ANNUALLY   | Parking brake and transmission "Park" mechanism operation | Park on a fairly steep hill and hold the vehicle with the parking brake only. This checks holding ability. For automatic transmission, check "Park" by releasing all brakes after shifting the transmission to "P" (Park).   |
|   | Starter safety switch operation                           | <b>Caution:</b> Before performing the following safety switch check, be sure to have enough room around the vehicle. Then, firmly apply both the parking brake (see Owner's Manual for procedure) and the regular brakes. Do not use the accelerator pedal. If the engine starts, be ready to turn off the ignition promptly. Take these precautions because the vehicle could move without warning and possibly cause personal injury or property damage. |
|   |   | On automatic transmission vehicles, try to start the engine in each gear. The starter should crank only in "P" (Park) or "N" (Neutral).  |
|   |   | On manual transmission vehicles place the shift lever in "Neutral" push the clutch halfway and try to start. The starter should crank only when the clutch is fully depressed.   |
|   | Seatback latch operation                                  | Be sure seatbacks latch on those vehicles with folding seats using mechanical latches. See Owner's Manual for inertial latch operating information.  |
|   | Lap and shoulder belts condition and operation            | Inspect belt system, including, webbing, buckles, latch plates, retractors, guide loops and anchors.   |
|   | Movable head restraint operation                          | On vehicles with movable restraints, make sure restraints stay in the desired position. (See adjustment instructions in Owner's Manual.)   |
|   | Seatback recliner operation (if equipped)                 | Make sure the recliner is holding by pushing and pulling on the top of the seatback while it is reclined.  |
|   | Spare tire and jack storage                               | Be alert to rattles in rear of vehicle. Make sure the spare tire, all jacking equipment and any covers or doors are securely stowed at all times. Oil jack ratchet mechanism after each use.   |
|   | Underbody flushing  | At least every spring, flush from the underbody with plain water any corrosive materials used for ice and snow removal and dust control. Take care to thoroughly clean any areas where mud and other debris can collect. Sediment packed in closed areas of the vehicle should be loosened before being flushed.   |
|   | Steering column lock operation                            | While parked, try to turn key to "Lock" in each gear range. The key should turn to "Lock" only when gear is in "Park" on automatic or "Reverse" on manual transmission. On vehicles with key release lever, try to turn key to "Lock" without depressing the lever. The key should turn to "Lock" only with the key lever depressed. On all vehicles, the key should come out only in "Lock".  |
|   | Thermostatically controlled air cleaner                   | Inspect all hoses and ducts for proper hookup. Be sure valve works properly.   |

Fig. 0B-15--Owner Inspection and Services, Chart B

**SECTION A—1983 Vehicle Maintenance Schedule**

| Item No. | To Be Serviced                                   | When to Perform   | The services shown in this schedule up to 48,000 miles (76 800km) are to be performed after 48,000 miles at the same intervals |                          |                          |                          |                          |                          |                          |                          |
|----------|--|---|--|--------------------------|--------------------------|--------------------------|--------------------------|--------------------------|--------------------------|--------------------------|
|          |  |   | 6,000 Mi.<br>(9 600km)   | 12,000 Mi.<br>(19 200km) | 18,000 Mi.<br>(28 800km) | 24,000 Mi.<br>(38 400km) | 30,000 Mi.<br>(48 000km) | 36,000 Mi.<br>(57 600km) | 42,000 Mi.<br>(67 200km) | 48,000 Mi.<br>(76 800km) |
| 1        | Chassis Lubrication                              | Every 4 Months or 6,000 Miles (9 600km)   | •  | •                        | •                        | •                        | •                        | •                        | •                        | •                        |
| 2        | Engine Oil and Filter*                           | See Explanation for service intervals   |  |                          |                          |                          |                          |                          |                          |                          |
| 3        | Carburetor Choke Check*                          | Every 24 Months or 24,000 Miles (38 400km)  |  |                          |                          | •                        |                          |                          |                          | •                        |
| 4        | Carburetor Mounting Torque*                      | Every 12 Months or 12,000 Miles (19 200km)  |  | •                        |                          | •                        |                          | •                        |                          | •                        |
| 5        | Engine Idle Speed Adjustment*                    | At 1st 4 Months or 6,000 Miles (9 600km)—then at 12 Month 12,000 Mile (19 200km) intervals  | •  | •                        |                          | •                        |                          | •                        |                          | •                        |
| 6        | AIR Pump Drive Belts                             |   |  | •                        |                          | •                        |                          | •                        |                          | •                        |
| 7        | Cooling System Refill                            | Every 12,000 Miles (19 200km)   |  | •                        |                          | •                        |                          | •                        |                          | •                        |
| 8        | Wheel Bearing Repack                             |   |  | •                        |                          | •                        |                          | •                        |                          | •                        |
| 9        | Automatic Transmission Fluid                     | Every 24,000 Miles (38 400km)   |  |                          |                          | •                        |                          | •                        |                          | •                        |
| 10       | Vacuum Advance System Check*                     |   |  |                          |                          | •                        |                          | •                        |                          | •                        |
| 11       | Fuel Tank, Cap and Lines*                        | Every 24 Months or 24,000 Miles (38 400km)  |  |                          |                          | •                        |                          | •                        |                          | •                        |
| 12       | Idle Stop Solenoid Check*                        | At 1st 4 Months or 6,000 Miles (9 600 km)—then at 12 Month 12,000 Mile (19 200km) intervals | •  | •                        |                          | •                        |                          | •                        |                          | •                        |
| 13       | Spark Plug Wire Check & Plug Replacement†        |   |  | •                        |                          | •                        |                          | •                        |                          | •                        |
| 14       | Engine Timing Adjust & Distributor Check ‡       | Every 12,000 Miles (19 200km)   |  | •                        |                          | •                        |                          | •                        |                          | •                        |
| 15       | Air Cleaner Element Replacement ‡                |   |  | •                        |                          | •                        |                          | •                        |                          | •                        |
| 16       | Thermo Controlled Air Cleaner Check ‡            |   |  | •                        |                          | •                        |                          | •                        |                          | •                        |
| 17       | Manifold Heat Valve Check ‡                      |   |  | •                        |                          | •                        |                          | •                        |                          | •                        |
| 18       | Carburetor Fuel Filter Replacement†              | Every 12 Months or 12,000 Miles (19 200km)  |  | •                        |                          | •                        |                          | •                        |                          | •                        |
| 19       | Throttle Return Control Check†                   |   |  | •                        |                          | •                        |                          | •                        |                          | •                        |
| 20       | PCV System Check†                                |   |  | •                        |                          | •                        |                          | •                        |                          | •                        |
| 21       | ECS System Check†                                |   |  | •                        |                          | •                        |                          | •                        |                          | •                        |
| 22       | Engine Idle Mixture Adjust (4.8L L-6 only)†      | Every 24 Months or 24,000 Miles (38 400km)  |  |                          |                          | •                        |                          | •                        |                          | •                        |
| 23       | EFE System Check†                                |   |  |                          |                          | •                        |                          | •                        |                          | •                        |
| 24       | Thermostatically Controlled Engine Cooling Fan ‡ | Every 12 Months or 12,000 Miles (19 200km)  |  | •                        |                          | •                        |                          | •                        |                          | •                        |
| 25       | Shields and Underhood Insulation ‡               | Every 12,000 Miles (19 200km)   |  | •                        |                          | •                        |                          | •                        |                          | •                        |
| 26       | Air Intake System ‡                              |   |  | •                        |                          | •                        |                          | •                        |                          | •                        |
| 27       | Governor ‡                                       | Every 48 Months or 48,000 Miles (76 800km)  |  |                          |                          |                          |                          |                          |                          | •                        |

\* Also an Emission Control ‡ Also a Noise Emission Control Service † Applicable only to vehicles sold only in the United States

Fig. 0B-21--Maintenance Schedule, Gasoline, H.D. Emission

**GASOLINE ENGINE, H.D. EMISSION**

**NORMAL VEHICLE USE**

The maintenance instructions contained in this section are based on the assumption that your vehicle will be used as designed:

- to carry passengers and cargo within the limitations indicated on the Tire Placard.
- on reasonable road surfaces within legal operating limits, and
- on a daily basis, as a general rule, for at least several miles (km).

Unusual operating conditions will require more frequent vehicle maintenance as specified.

**EXPLANATION OF SCHEDULED MAINTENANCE SERVICES**

**Item 1 Chassis Lubrication**

Lubricate all grease fittings in front suspension, steering linkage, and constant velocity universal joint. Lubricate transmission and transfer case shift linkage, hood latch, hood and door hinges, parking brake cable guides, clutch linkage, propeller shaft slip joint, transfer case shift lever, universal joints, and brake and clutch pedal springs. Lubricate suspension and steering linkage every 3 months or 3,000 miles (4 800 km) when operating under dusty or muddy conditions and in extensive off-road use. Also, lubricate clutch cross-shaft lever every 36,000 miles (57 600 km).

**Item 2 Engine Oil and Oil Filter**

Oil and filter change intervals depend upon how you use your vehicle. The information in Figs. 0B-22 and 0B-23 should assist in determining the proper oil and filter change intervals.

**Item 3 Carburetor Choke and Hoses**

Verify that choke and vacuum break work properly. Correct any binding caused by damage or gum on the choke shaft. Inspect hoses for proper hookup, cracks, rubbing or decay. Correct as necessary.

**Item 4 Carburetor Mounting**

Torque mounting bolts and/or nuts at mileage shown in Maintenance Schedule.

**Item 5 Engine Idle Speed Adjustment**

Adjust to the specifications shown on the underhood label. You must use calibrated test equipment.

**Item 6 AIR Pump Drive Belts**

Inspect belts driving the AIR pump. Look for cracks, fraying wear, and proper tension. Adjust or replace as needed.

**Item 7 Cooling System**

Drain, flush and refill system with new coolant as shown in your Owner's Manual.

| TYPE OF USE   | CHANGE INTERVAL  |
|---|--|
| Frequent long runs at high speeds and high ambient temperatures.  | Change engine oil and filter every 3,000 miles (4800 km) or 2 months, whichever comes first.   |
| Operating in dusty areas.   |  |
| Towing a trailer.   |  |
| Idling for extended periods and/or low speed operation such as found in police, taxi or door-to-door delivery.  |  |
| Operating when outside temperatures remain below freezing and when most trips are less than 4 miles (6 km).   | Change engine oil every 6,000 miles (9600 km) or 4 months, whichever comes first.<br>Change engine oil filter at first oil change, then every other oil change if mileage determines when you change oil. If time determines change intervals, change the filter with each oil change. |
| Operating on a daily basis as a general rule, for several miles and when none of the above conditions apply.  |  |
| Always change oil and filter as soon as possible after driving in a dust storm. ALSO, ALWAYS USE SF-QUALITY OILS OF THE PROPER VISCOSITY. See Owner's Manual for further details. |  |

Fig. 0B-22--Engine Oil Change Interval Chart

**Item 8 Wheel Bearing Repack**

Clean and repack front wheel bearings at each brake relining or 12,000 miles (19 200 km), whichever comes first.

Be sure to use lubricant as specified in Fig. 0B-27.

**Item 9 Transmission Fluid**

**Automatic Transmission** - Change the transmission fluid and change the filter (or service the screen) every 12,000 miles (19 200 km) if the vehicle is mainly driven under one or more of these hot conditions:

- In heavy city traffic where the outside temperature regularly reaches 90°F (32°C).
- In hill or mountain areas.
- Frequent trailer pulling.
- Uses such as taxi, police or delivery service.

If vehicle is not used under any of these conditions, change the fluid and filter (or service the screen) every 24,000 miles (38 400 km).

See Owner's Manual for further details.

**Item 10 Vacuum Advance System and Hoses**

Check that system works properly. Check hoses for proper hookup, cracks, rubbing or decay. Replace parts as needed.

**Item 11 Fuel Tank, Cap and Lines**

Inspect for damage or leaks. Remove fuel cap, and inspect gasket for an even filler neck imprint, and any damage. Replace as needed.

**Item 12 Idle Stop Solenoid and/or Dashpot**

Check that parts work properly. Replace them as needed.

**Item 13 Spark Plug Wires and Plug Replacement**

Clean wires. Remove corrosion on terminals. Inspect the wires for checks, burns, cracks or other damage. Check the boot fit at distributor cap and spark plugs. Replace wire if damaged or if corrosion cannot be cleaned. Replace spark plugs as shown on Schedule. Use the type listed in your Owner's Manual.

**Item 14 Timing and Distributor Cap**

Adjust timing to underhood label specifications. Inspect the inside and outside of the cap and rotor for cracks, carbon tracking and corrosion. Clean or replace as needed.

**Item 15 Air Cleaner Element**

Replace at mileage shown on Schedule. Replace more often under dusty conditions. Ask your dealer for the proper replacement times for your driving conditions.

**Item 16 Thermostatically Controlled Air Cleaner**

Inspect all hoses and ducts for correct hookup. Be sure valve works properly.

**Item 17 Manifold Heat Valve**

Some engines are equipped with a manifold heat valve which should be inspected and repaired as necessary to insure free operation.

**Item 18 Carburetor Fuel Filter**

Replace at mileage shown on Maintenance Schedule or sooner if clogged.

**Item 19 Throttle Return Control (TRC) System**

Check hoses for proper connections, cracking, abrasion, or deterioration and replace as necessary. Check for proper operation of system. Check for shorted or broken wires and ensure electrical connectors are fully engaged at distributor, speed switch and vacuum solenoid.

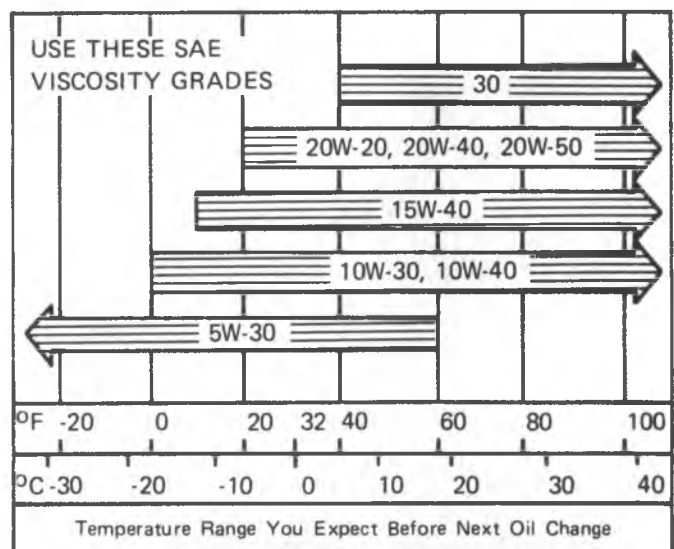

Fig. 0B-23--Oil Viscosity Chart

**Item 20 Positive Crankcase Ventilation System (PCV)**

Check that system works properly each 12,000 miles (19 200 km). Each 24,000 miles (38 400 km); replace the valve, replace any worn, plugged or collapsed hoses and replace filter.

**Item 21 Evaporation Control System (ECS)**

Check all fuel and vapor lines and hoses for proper hookup, routing, and condition. Check that bowl vent and purge valves work properly if equipped. Remove canister, check for cracks or damage. Replace as needed.

**Item 22 Engine Idle Mixture (4.8L; L6 Only)**

At designated intervals or in case of a major carburetor overhaul, or when poor idle quality exists, adjust mixture by a mechanical method (lean drop), following the specifications shown on the label under the hood.

**Item 23 Early Fuel Evaporation (EFE) System**

Check that valve works properly; correct any binding. Check that thermal vacuum switch works properly. Check hoses for cracks, rubbing or decay. Replace part as needed.

**Item 24 Thermostatically Controlled Engine Cooling Fan**

(If so equipped) With the engine off and below normal operating temperature, check to see that the fan can be rotated by hand on fluid coupling, viscous and air operated drives. Replace as necessary. For air-operated fan drives,

the air pressure must be up to the normal operating range to perform the above check.

**Item 25 Shields and Underhood Insulation**

(If so equipped) Inspect shields and underhood insulation for damage or looseness. Adjust or replace as required.

**Item 26 Air Intake System**

Check the air intake system installation to see that gaskets are seated properly and all hose connections, fasteners, and other components are tight. For gasoline engines, also check to be sure air cleaner housing is properly seated on the carburetor, that the cover fits tightly, and that the wing nut is tight. Tighten connections and fasteners or replace damaged parts as required.

**Item 27 Governor**

(If so equipped) Check the engine no-load governed speed and reset to specifications as required.

**OWNER INSPECTIONS AND SERVICES**

Listed in Figs 0B-24 through 0B-26 are vehicle inspections and services which should be made by either you or a qualified technician at the frequencies indicated to help ensure proper safety, emission performance and dependability of your vehicle. Take any problems promptly to your dealer or a qualified technician for service advice. Whenever repairs are necessary, have them completed at once. For your safety and that of others, any safety related components that could have been damaged in an accident should be inspected. All needed repairs should be performed before operating your vehicle.

| FREQUENCY                            | INSPECTION OR SERVICE   | WHAT TO DO   |
|--------------------------------------|---|--|
| <b>BEFORE OPERATING YOUR VEHICLE</b> | Warning light, buzzer tone and chime operation.   | Check operation of all warning lights, buzzers, tone generators and chimes — also all interior lights. See your Owner's Manual for details.  |
|                                      | Glass condition   | Look for broken, scratched or damaged glass that could reduce vision or cause injury. Replace or repair promptly.  |
|                                      | Seat adjuster operation   | When adjusting a manual seat, be sure seat adjusters latch by pushing seat forward and backward.   |
|                                      | Rearview mirror and sun visor operation   | Make sure friction joints hold mirrors and sun visors in place.  |
|                                      | Door and gate latch operation   | Make sure that all doors and wagon or hatchback gates close, latch and lock tightly.   |
| <b>WHILE OPERATING YOUR VEHICLE</b>  | Automatic transmission shift indicator operation  | Make sure the indicator points to the gear chosen.   |
|                                      | Windshield wiper and washer operation   | Note the operation and condition of the wiper blades and the flow and aim of the washer spray.   |
|                                      | Defroster operation   | Periodically check the air flow from the ducts at the inside base of the windshield. Do this with the heater control lever in "defrost" position and fan lever in "high".  |
|                                      | Horn operation  | Blow horn occasionally to make sure it works. Check all button locations.  |
|                                      | Brake system operation  | Be alert to strange sounds, increased brake pedal travel or repeated pulling to one side when braking. Also, if the brake warning light goes on, something may be wrong. See your Owner's Manual.  |
|                                      | Exhaust system operation  | Be alert to any changes in the sound of the system or any smell of fumes. These are signs the system may be leaking. Have it inspected and repaired at once. Also see "Engine Exhaust Gas Caution (Carbon Monoxide)" in your Owner's Manual.       |
|                                      | Tires, Wheels and Alignment   | Be alert to a vibration of the steering wheel or seat at normal highway speeds. This may mean a wheel balance is needed. Also, a pull right or left on a straight, level road may show the need for a tire pressure adjustment or wheel alignment. |
|                                      | Steering system operation   | Be alert to changes in steering action. An inspection is needed when the steering wheel is harder to turn, or has too much free play, or if strange sounds are noted when turning or parking.  |
| Headlight aim                        | Take note of light pattern occasionally. If beams seem improperly aimed, headlights should be adjusted. |  |
| <b>AT EACH FUEL FILL</b>             | Engine oil level†   | Check level and add if necessary. See Owner's Manual. Section 5.   |
|                                      | Engine coolant level and condition†   | Check level in coolant recovery tank and add if necessary. Inspect coolant and replace if dirty or rusty. See Owner's Manual. Section 5.   |
|                                      | Windshield washer fluid level   | Check level in reservoir and add if necessary.   |
|                                      | Hood latch operation  | When opening hood, note the operation of secondary latch. It should keep hood from opening all the way when primary latch is released. Make sure that hood closes firmly after services are performed.   |

Fig. 0B-24--Owner Inspections and Services, Chart A



| FREQUENCY   | INSPECTION OR SERVICE                                     | WHAT TO DO  |
|---|---|---|
| AT LEAST MONTHLY  | Tire pressure check                                       | Maintain pressures as shown on Tire Placard on the driver's door (include spare). Pressure should be checked when tires are "cold".   |
|   | Light operation   | Check operation of license plate light, sidemarker lights, headlights, parking lights, taillights, brake lights, turn signals, backup lamps and hazard warning flashers.  |
|   | Fluid leak check  | Periodically, after the vehicle has been parked for a while, inspect the surface beneath the vehicle for water, oil, fuel or other fluids. Water dripping from the air conditioning system after use is normal. If you notice fuel leaks or fumes, the cause should be found and corrected at once.   |
| AT LEAST SEMI-ANNUALLY (FOR EXAMPLE, EVERY SPRING AND FALL) | Automatic transmission fluid level                        | Maintain level within operating range on dipstick. Refer to Owner's Manual, Section 5.  |
|   | Power steering pump reservoir level                       | Check level in accordance with Owner's Manual instructions (Section 5) and keep at proper level.  |
|   | Brake master cylinder reservoir level                     | Check fluid level. Note: A low fluid level can indicate worn disc brake pads and should be checked.   |
|   | Clutch Pedal free travel                                  | Note the clutch pedal free travel. It should be about 1". Adjust linkage whenever there is little or no free travel.  |
| AT LEAST ANNUALLY   | Parking brake and transmission "Park" mechanism operation | Park on a fairly steep hill and hold the vehicle with the parking brake only. This checks holding ability. For automatic transmission, check "Park" by releasing all brakes after shifting the transmission to "P" (Park).  |
|   | Starter safety switch operation                           | <b>Caution:</b> Before performing the following safety switch check, be sure to have enough room around the vehicle. Then, firmly apply both the parking brake (see Owner's Manual for procedure) and the regular brakes. Do not use the accelerator pedal. If the engine starts, be ready to turn off the ignition promptly. Take these precautions because the vehicle could move without warning and possibly cause personal injury or property damage.<br>On automatic transmission vehicles, try to start the engine in each gear. The starter should crank only in "P" (Park) or "N" (Neutral).<br>On manual transmission vehicles place the shift lever in "Neutral" push the clutch halfway and try to start. The starter should crank only when the clutch is fully depressed. |
|   | Seatback latch operation                                  | Be sure seatbacks latch on those vehicles with folding seats using mechanical latches. See Owner's Manual for inertial latch operating information.   |
|   | Lap and shoulder belts condition and operation            | Inspect belt system, including: webbing, buckles, latch plates, retractors, guide loops and anchors.  |
|   | Movable head restraint operation                          | On vehicles with movable restraints, make sure restraints stay in the desired position. (See adjustment instructions in Owner's Manual.)  |
|   | Seatback recliner operation (if equipped)                 | Make sure the recliner is holding by pushing and pulling on the top of the seatback while it is reclined.   |
|   | Spare tire and jack storage                               | Be alert to rattles in rear of vehicle. Make sure the spare tire, all jacking equipment, and any covers or doors are securely stowed at all times. Oil/jack ratchet mechanism after each use.   |
|   | Underbody flushing  | At least every spring, flush from the underbody with plain water any corrosive materials used for ice and snow removal and dust control. Take care to thoroughly clean any areas where mud and other debris can collect. Sediment packed in closed areas of the vehicle should be loosened before being flushed.  |
|   | Steering column lock operation                            | While parked, try to turn key to "Lock" in each gear range. The key should turn to "Lock" only when gear is in "Park" on automatic or "Reverse" on manual transmission. On vehicles with key release lever, try to turn key to "Lock" without depressing the lever. The key should turn to "Lock" only with the key lever depressed. On all vehicles, the key should come out only in "Lock".   |
|   | Thermostatically controlled air cleaner*                  | Inspect all hoses and ducts for proper hookup. Be sure valve works properly.  |

Fig. OB-25--Owner Inspection and Services, Chart B

| FREQUENCY                                 | INSPECTION OR SERVICE  | WHAT TO DO   |
|---|--|--|
| <p><b>AT<br/>LEAST<br/>ANNUALLY</b></p>   | <p>Engine cooling system*</p>  | <p>Inspect coolant and freeze protection. If dirty or rusty, drain, flush and refill with new coolant as shown in your Owner's Manual. Keep coolant at the proper mixture as specified in your Owner's Manual. This provides proper freeze protection, corrosion inhibitor level and engine operating temperature. Inspect hoses and replace if cracked, swollen or rotted. Tighten hose clamps. Clean outside of radiator and air conditioning condenser. Wash radiator filler cap and neck. To help ensure proper operation, a pressure test of both the cooling system and cap is also recommended.</p>   |
|   | <p><b>EACH TIME<br/>OIL IS<br/>CHANGED<br/>(WHEN<br/>VEHICLE<br/>IS ON<br/>HOIST</b></p> | <p>Tire and wheel inspection and rotation</p>  |
| <p>Brake systems inspection</p>           |  | <p>For convenience the following should be done when wheels are removed for rotation: Inspect lines and hoses for proper hookup, binding, leaks, cracks, chafing etc. Inspect disc brake pads for wear and rotors for surface condition. Also inspect drum brake linings for wear and cracks. Inspect other brake parts, including drums, wheel cylinders, parking brake, etc. at the same time. Check parking brake adjustment.<br/><b>INSPECT BRAKES MORE OFTEN IF HABIT OR CONDITIONS RESULT IN FREQUENT BRAKING.</b></p>   |
| <p>Steering and suspension</p>            |  | <p>Inspect front and rear suspension and steering system for damaged, loose or missing parts, signs of wear or lack of lubrication. Inspect power steering lines and hoses for proper hookup, binding, leaks, cracks, chafing, etc. (On vehicles equipped with manual steering gear, check for seal leakage.) Inspect final drive axle output shaft seals for leaking.<br/>● Front Suspension and Steering Linkage<br/>(a) On C20 and G30, lubricate every 4 months or 6,000 miles (9 000 km).<br/>(b) On all other vehicles, lubricate every 12 months or 7,500 miles (12 000 km).<br/>(c) Lubricate suspension and steering linkage every 3 months or 3,000 miles (4 800 km) when operating under dusty or muddy conditions and in extensive off-road use.</p>   |
| <p>Exhaust system inspection*</p>         |  | <p>Inspect complete system. Inspect body near the exhaust system. Look for broken, damaged, missing or out-of-position parts as well as open seams, holes, loose connections or other conditions which could cause a heat build up in the floor pan or could let exhaust fumes seep into the trunk or passenger compartment.</p>   |
| <p>Throttle linkage inspection</p>        |  | <p>Inspect for damaged or missing parts, interference or binding.</p>  |
| <p>Engine drive belts</p>                 |  | <p>Inspect all belts for cracks, fraying wear and proper tension. Adjust or replace as needed.</p>   |
| <p>Rear axle/front axle/transfer case</p> |  | <p>Check fluid level and add if needed.<br/>● Locking Differential - In general service, drain fluid at 6000 miles (9600 km) and refill. Change fluid at 12,000 mile intervals, and check fluid and add as needed at 6000 mile intervals thereafter. In severe operating conditions, or trailer towing applications, drain fluid every 6000 miles (9600 km) and refill.<br/>● Standard Differential - In general service, drain fluid level every 24,000 miles (38,400 km) and refill. Check fluid level and add as needed at 6000 mile (9600 km) intervals. In severe operating conditions, or trailer towing applications, drain fluid every 12,000 miles (19,200 km) and refill. Check fluid level and add as needed at 6000 mile (9600 km) intervals.<br/>● Four Wheel Drive - Every 4 months or 6,000 miles (9 600 km), check front axle and transfer case and add lubricant when necessary. Lubricate propeller shaft slip joint and constant velocity universal joint. Oil control lever pivot points and exposed control linkage. Check vent hose at front axle and transfer case for leaks and proper installation. More frequent lubrication may be required on heavy duty off-road operations. See Owner's and Driver's Manual for further information.</p> |
| <p>Manual transmission</p>                |  | <p>Check fluid level and add as required.</p>  |

Fig. 0B-26--Owner Inspections and Services, Chart C

| USAGE  | FLUID/LUBRICANT  |
|--|--|
| Engine   | "SF" or "SF/CD" or "SF/CC" Engine Oil conforming to GM spec. 6048-M  |
| Engine Coolant   | Mixture of water and a high quality Ethylene Glycol base type antifreeze conforming to GM spec. 1825-M (GM Part No. 1052753) or equivalent |
| Brake System   | Delco Supreme 11 fluid or DOT-3  |
| Parking Brake Cables   | Chassis grease meeting requirements of GM spec. 6031-M   |
| Power Steering System  | GM power steering fluid Part No. 1050017 or equivalent   |
| Manual Steering Gear   | Lubricant GM Part No. 1051052 or equivalent  |
| Automatic Transmission Transfer Case   | DEXRON®II Automatic Transmission Fluid   |
| Differential—Standard Manual Transmission  | SAE-80W, GL-5 or SAE-80W-90 GL-5 gear lubricant (SAE-80W—GL-5 in Canada)   |
| Differential—Locking   | Lubricant GM Part No. 1052271  |
| Manual Transmission Shift Linkage, Column Shift, Propeller Shaft Slip Joint  | Chassis grease meeting requirements of GM spec. 6031-M   |
| Key Lock Cylinders   | WD-40 Spray Lubricant or equivalent  |
| Clutch Linkage (Man. Trans. only)<br>a. Pivot points<br>b. Push rod to clutch fork joint, and cross shaft pressure fitting                                       | a. Engine oil<br>b. Chassis grease meeting requirements of GM spec. 6031-M   |
| Chassis Lubrication  | Chassis grease meeting requirements of GM spec. 6031-M   |
| Windshield Washer Solvent  | GM Optikleen washer solvent Part No. 1051515 or equivalent   |
| Hood Latch Assembly<br>a. Pivots and spring anchor<br>b. Release pawl  | a. Engine oil<br>b. Chassis grease   |
| Front Wheel Bearings   | Lubricant GM Part No. 1051344 (one pound) or equivalent*   |
| Constant Velocity Universal Joint  | GM Lubricant Part No. 1052497 or equivalent  |
| Automatic Transmission Shift Linkage, Floor Shift Linkage, Hood and Door hinges, body door hinge pins, tailgate hinge and linkage, folding seat, fuel door hinge | Engine Oil   |

\* Fluids and lubricants identified with GM part numbers or GM specification numbers may be obtained from your GM dealer.

Fig. OB-27--Recommended Fluids and Lubricants

**SECTION A—Scheduled Maintenance Services For Your 1983 Diesel-Fueled Vehicle**

| Item No. | To Be Serviced                                  | When to Perform Months or Miles (Kilometers) Whichever Occurs First   | The services shown in this schedule up to 45,000 miles (72,000km) are to be performed after 45,000 miles at the same intervals |                       |                       |                       |                       |                       |                       |                       |                       |
|----------|---|---|--|-----------------------|-----------------------|-----------------------|-----------------------|-----------------------|-----------------------|-----------------------|-----------------------|
|          |   |   | 5,000 Mi. (8,000km)  | 10,000 Mi. (16,000km) | 15,000 Mi. (24,000km) | 20,000 Mi. (32,000km) | 25,000 Mi. (40,000km) | 30,000 Mi. (48,000km) | 35,000 Mi. (56,000km) | 40,000 Mi. (64,000km) | 45,000 Mi. (72,000km) |
| 1        | Chassis Lubrication                             | Lubricate every 12 Months or 5,000 Miles (8,000km)                    | •  | •                     | •                     | •                     | •                     | •                     | •                     | •                     | •                     |
| 2        | Engine Oil & Filter*                            | See Explanation for service intervals                                 |  |                       |                       |                       |                       |                       |                       |                       |                       |
| 3        | Exhaust Pressure Regulator Valve*               | Inspect at 5,000 Miles (8,000 km), then every 15,000 Miles (24,000km) | •  |                       | •                     |                       |                       | •                     |                       |                       | •                     |
| 4        | Engine Idle Speed Check*                        | Check at 5,000 Miles (8,000km) then at 30,000 Miles (48,000km)        | •  |                       |                       |                       |                       | •                     |                       |                       |                       |
| 5        | Crankcase Ventilation System*                   | Service every 12 Months or 15,000 Miles (24,000km)                    |  |                       | •                     |                       |                       | •                     |                       |                       | •                     |
| 6        | Cooling System Refill*                          | Every 24 Months or 30,000 Miles (45,000km)                            |  |                       |                       |                       |                       | •                     |                       |                       |                       |
| 7        | Front Wheel Bearings Repack                     | Every 30,000 Miles (48,000km)   |  |                       |                       |                       |                       | •                     |                       |                       |                       |
| 8        | Automatic Transmission Fluid                    | See Explanation for service intervals                                 |  |                       |                       |                       |                       |                       |                       |                       |                       |
| 9        | Air Cleaner*                                    | Replace every 30,000 Miles (48,000km)**                               |  |                       |                       |                       |                       | •                     |                       |                       |                       |
| 10       | Fuel Filters*                                   | Replace every 15,000 Miles (24,000km)                                 |  |                       | •                     |                       |                       | •                     |                       |                       | •                     |
| 11       | Thermostatically Controlled Engine Cooling Fan▲ | Every 12 Months or 10,000 Miles (16,000km)                            | •  |                       | •                     |                       |                       | •                     |                       |                       | •                     |
| 12       | Shields and Underhood Insulation▲               | Every 10,000 Miles (16,000km)   | •  |                       | •                     |                       |                       | •                     |                       |                       | •                     |
| 13       | Air Intake System▲                              |   | •  |                       | •                     |                       |                       | •                     |                       |                       | •                     |

\* Also An Emission Control Service. ▲ Also a Noise Emission Control Service (Applicable only to vehicles with Engine Family DGM06 2DAB2 and sold only in the United States)  
 \*\* For engines with Engine Family DGM06 2DAB2, replace element every 15,000 miles (24,000km)  
 \*\*\* Only these emissions control maintenance items are considered to be required maintenance as defined by the California Air Resources Board (ARB) regulations and are, according to such regulations, the minimum maintenance an owner in California must perform to fulfill the minimum requirements of the emission warranty. All other emission maintenance items are recommended maintenance as defined by such regulations. General Motors urges that all emission control maintenance items be performed. (Only applicable to Engine Family DGM06 2DAB2.)

Fig. 0B-31--Maintenance Schedule, Diesel

**DIESEL ENGINE**

**NORMAL VEHICLE USE**

The owner's or driver's maintenance instructions contained in this section are based on the assumption that your vehicle will be used as designed:

- to carry passengers and cargo within the limitations indicated on the Tire Placard.
- on reasonable road surfaces within legal operating limits.
- on a daily basis, as a general rule, for at least several miles (km) and
- on No. 1 or No. 2 grade diesel fuel.

Unusual operating conditions will require more frequent vehicle maintenance as specified.

**EXPLANATION OF SCHEDULED MAINTENANCE SERVICES**

**Item 1 Chassis Lubrication**

Lubricate all grease fittings in front suspension, steering linkage. Lubricate transmission shift linkage, hood latch, hood and door hinges, parking brake cable guides, clutch linkage, propeller shaft slip joint, universal joints, brake pedal springs, underbody contact points and linkage.

Lubricate suspension and steering linkage every 2 months or 2,500 miles (4,000 km) when operating under dusty or muddy conditions and extensive off-road use.

**Item 2 Engine Oil and Filter**

Oil and filter change intervals depend upon how you use your vehicle. The information in Figs. 0B-32 and 0B-33 should assist in determining the proper oil and filter change intervals.

**Item 3 Exhaust Pressure Regulator Valve**

Check that valve works properly. Correct any binding. Check hoses for cracks, rubbing or decay. Replace parts as needed.

**Item 4 Engine Idle Speed**

Adjust to the specifications shown on the underhood label. You must use calibrated test equipment.

**Item 5 Crankcase Ventilation System**

Inspect rubber fittings, hoses and regulator every 30,000 miles (48,000 km). Replace as required.

**Item 6 Cooling System Refill**

Drain, flush and refill system with new coolant as shown in your Owner's Manual.

**Item 7 Wheel Bearings**

Clean and repack front wheel bearings at each brake relining or 30,000 miles (48,000 km) whichever comes first. Use a lubricant as specified in Fig. 0B-37.

| TYPE OF USE   | CHANGE INTERVAL   |
|---|---|
| Frequent long runs at high speeds and high ambient temperatures.  | Change engine oil and filter every 2,500 miles (4000 km) or 3 months, whichever comes first.  |
| Operating in dusty areas.   |   |
| Towing a trailer.   |   |
| Idling for extended periods and/or low speed operation such as found in police, taxi or door-to-door delivery.  |   |
| Operating when outside temperatures remain below freezing and when most trips are less than 4 miles (6 km).   |   |
| Operating on a daily basis as a general rule, for several miles and when none of the above conditions apply.  | Change engine oil and filter every 5,000 miles (8000 km) or 12 months, whichever comes first. |
| Always change oil and filter as soon as possible after driving in a dust storm. ALSO, ALWAYS USE SF/CD or SF/CC QUALITY OILS OF THE PROPER VISCOSITY. See Owner's Manual for further details. |   |

Fig. 0B-32--Engine Oil Change Interval Chart

**Item 8 Automatic Transmission Fluid**

Change the transmission fluid and filter (or service the screen) every 15,000 miles (24 000 km) if the vehicle is mainly driven under one of more of these hot conditions:

- In heavy city traffic where the outside temperature regularly reaches 90°F (32°C).

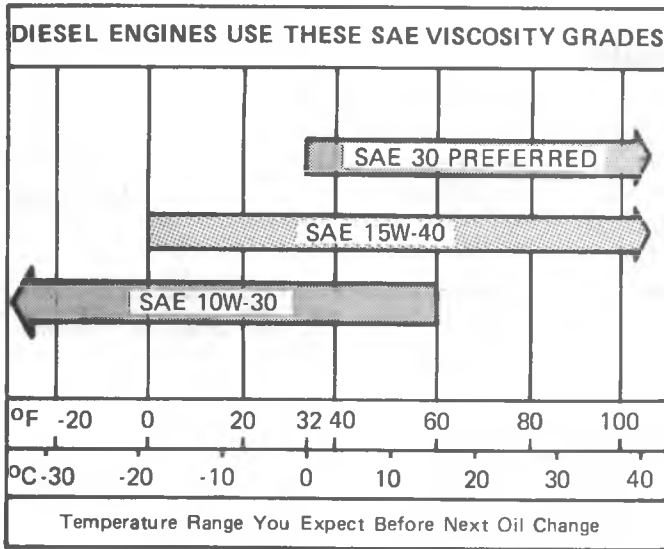

Fig. 0B-33--Oil Viscosity Chart

- In hill or mountain areas.
- Frequent trailer pulling.
- Uses such as taxi, police or delivery service.

If vehicle is not used mainly under any of these conditions, change the fluid and filter (or service the screen) every 100,000 miles (160 000 km).

See Owner's Manual for further details.

**Item 9 Air Cleaner Element**

Replace at 30,000 miles (48 000 km). Replace more often under dusty conditons. Ask your delaeer for the proper replacement times for your driving conditions.

**Item 10 Fuel Filters**

Replace primary and secondary fuel filter at mileage shown on Maintenance Schedule or sooner if clogged. Fill both filters with clean diesel fuel before installing.

**Item 11 Thermostatically Controlled Engine Cooling Fan**

If so equipped) With the engine off and below normal operating temperature, check to see that the fan can be rotated by hand on fluid coupling, viscous and air operated drives. Replace as necessary. For air-operated fan drives, the air pressure must be up to the normal operating range to perform the above check.

**Item 12 Shields and Underhood Insulation**

(If so equipped) Inspect shields and underhood insulation for damage or looseness. Adjust replace as required.

**Item 13 Air Intake System**

Check the air intake system installation to see that gaskets are seated properly and all hose connections, fasteners, and other components are tight. Tighten connections and fasteners or replace damaged parts as required.

**OWNER INSPECTIONS AND SERVICES**

Listed in Figs. 0B-34 through 0B-36 are vehicle inspections and services which should be made by either you or a qualified technician at the frequencies indicated to help ensure proper safety, emission performance and dependability of your vehicle. Take any problems promptly to your dealer or a qualified technician for service advice. Whenever repairs are necessary, have them completed at once. For your safety and that of others, any safety related components that could have been damaged in an accident should be inspected. All needed repairs should be performed before operating your vehicle.

| FREQUENCY                            | INSPECTION OR SERVICE   | WHAT TO DO   |
|--------------------------------------|---|--|
| <b>BEFORE OPERATING YOUR VEHICLE</b> | Warning light, buzzer tone and chime operation.   | Check operation of all warning lights, buzzers, tone generators and chimes — also all interior lights. See your Owner's Manual for details.  |
|                                      | Glass condition   | Look for broken, scratched or damaged glass that could reduce vision or cause injury. Replace or repair promptly.  |
|                                      | Seat adjuster operation   | When adjusting a manual seat, be sure seat adjusters latch by pushing seat forward and backward.   |
|                                      | Rearview mirror and sun visor operation   | Make sure friction joints hold mirrors and sun visors in place.  |
|                                      | Door and gate latch operation   | Make sure that all doors and gates close, latch and lock tightly.  |
| <b>WHILE OPERATING YOUR VEHICLE</b>  | Automatic transmission shift indicator operation  | Make sure the indicator points to the gear chosen.   |
|                                      | Windshield wiper and washer operation   | Note the operation and condition of the wiper blades and the flow and aim of the washer spray.   |
|                                      | Defroster operation   | Periodically check the air flow from the ducts at the inside base of the windshield. Do this with the heater control lever in "defrost" position and fan lever in "high".  |
|                                      | Horn operation  | Blow horn occasionally to make sure it works. Check all button locations.  |
|                                      | Brake system operation  | Be alert to strange sounds, increased brake pedal travel or repeated pulling to one side when braking. Also, if the brake warning light goes on, something may be wrong. See your Owner's Manual.  |
|                                      | Exhaust system operation  | Be alert to any changes in the sound of the system or any smell of fumes. These are signs the system may be leaking. Have it inspected and repaired at once. Also see "Engine Exhaust Gas Caution (Carbon Monoxide)" in your Owner's Manual.       |
|                                      | Tires, Wheels and Alignment   | Be alert to a vibration of the steering wheel or seat at normal highway speeds. This may mean a wheel balance is needed. Also, a pull right or left on a straight, level road may show the need for a tire pressure adjustment or wheel alignment. |
| Steering system operation            | Be alert to changes in steering action. An inspection is needed when the steering wheel is harder to turn, or has too much free play, or if strange sounds are noted when turning or parking. |  |
| <b>AT EACH FUEL FILL</b>             | Headlight aim   | Take note of light pattern occasionally. If beams seem improperly aimed, headlights should be adjusted.  |
|                                      | Engine oil level†   | Check level and add if necessary. See Owner's Manual.  |
|                                      | Engine coolant level and condition†   | Check level in coolant recovery tank and add if necessary. Inspect coolant and replace if dirty or rusty. See Owner's Manual.  |
|                                      | Windshield washer fluid level   | Check level in reservoir and add if necessary.   |
|                                      | Hood latch operation  | When opening hood, note the operation of secondary latch. It should keep hood from opening all the way when primary latch is released. Make sure that hood closes firmly after services are performed.   |

Fig. 0B-34--Owners Inspections and Service, Chart A

| FREQUENCY   | INSPECTION OR SERVICE                                     | WHAT TO DO  |
|---|---|---|
| AT LEAST MONTHLY  | Tire pressure check                                       | Maintain pressures as shown on Tire Placard on the driver's door (include spare). Pressure should be checked when tires are "cold".   |
|   | Light operation   | Check operation of license plate light, sidemarker lights, headlights, parking lights, taillights, brake lights, turn signals, backup lamps and hazard warning flashers.  |
|   | Fluid leak check  | Periodically, after the vehicle has been parked for a while, inspect the surface beneath the vehicle for water, oil, fuel or other fluids. Water dripping from the air conditioning system after use is normal. If you notice fuel leaks or fumes, the cause should be found and corrected at once.   |
| AT LEAST SEMI-ANNUALLY (FOR EXAMPLE, EVERY SPRING AND FALL) | Automatic transmission fluid level                        | Maintain level within operating range on dipstick. Refer to Owner's Manual, Section 5.  |
|   | Power steering pump reservoir level                       | Check level in accordance with Owner's Manual instructions (Section 5) and keep at proper level.  |
|   | Brake master cylinder reservoir level                     | Check fluid level. Note: A low fluid level can indicate worn disc brake pads and should be checked.   |
|   | Clutch Pedal free travel                                  | Note the clutch pedal free travel. It should be about 1". Adjust linkage whenever there is little or no free travel.  |
| AT LEAST ANNUALLY   | Parking brake and transmission "Park" mechanism operation | Park on a fairly steep hill and hold the vehicle with the parking brake only. This checks holding ability. For automatic transmission, check "Park" by releasing all brakes after shifting the transmission to "P" (Park).  |
|   | Starter safety switch operation                           | <b>Caution:</b> Before performing the following safety switch check, be sure to have enough room around the vehicle. Then, firmly apply both the parking brake (see Owner's Manual for procedure) and the regular brakes. Do not use the accelerator pedal. If the engine starts, be ready to turn off the ignition promptly. Take these precautions because the vehicle could move without warning and possibly cause personal injury or property damage.<br>On automatic transmission vehicles, try to start the engine in each gear. The starter should crank only in "P" (Park) or "N" (Neutral).<br>On manual transmission vehicles place the shift lever in "Neutral" push the clutch halfway and try to start. The starter should crank only when the clutch is fully depressed. |
|   | Seatback latch operation                                  | Be sure seatbacks latch on those vehicles with folding seats using mechanical latches. See Owner's Manual for inertial latch operating information.   |
|   | Lap and shoulder belts condition and operation            | Inspect belt system, including: webbing, buckles, latch plates, retractors, guide loops and anchors.  |
|   | Movable head restraint operation                          | On vehicles with movable restraints, make sure restraints stay in the desired position. (See adjustment instructions in Owner's Manual.)  |
|   | Seatback recliner operation (if equipped)                 | Make sure the recliner is holding by pushing and pulling on the top of the seatback while it is reclined.   |
|   | Spare tire and jack storage                               | Be alert to rattles in rear of vehicle. Make sure the spare tire, all jacking equipment, and any covers or doors are securely stowed at all times. Oil jack ratchet mechanism after each use.   |
|   | Underbody flushing  | At least every spring, flush from the underbody with plain water any corrosive materials used for ice and snow removal and dust control. Take care to thoroughly clean any areas where mud and other debris can collect. Sediment packed in closed areas of the vehicle should be loosened before being flushed.  |
|   | Steering column lock operation                            | While parked, try to turn key to "Lock" in each gear range. The key should turn to "Lock" only when gear is in "Park" on automatic or "Reverse" on manual transmission. On vehicles with key release lever, try to turn key to "Lock" without depressing the lever. The key should turn to "Lock" only with the key lever depressed. On all vehicles, the key should come out only in "Lock".   |
|   | Engine cooling system*                                    | Inspect coolant and freeze protection. If dirty or rusty, drain, flush and refill with new coolant as shown in your Owner's Manual. Keep coolant at the proper mixture as specified in your Owner's Manual. This provides proper freeze protection, corrosion inhibitor level and engine operating temperature. Inspect hoses and replace if cracked, swollen or rotted. Tighten hose clamps. Clean outside of radiator and air conditioning condenser. Wash radiator filler cap and neck. To help ensure proper operation, a pressure test of both the cooling system and cap is also recommended.   |

Fig. OB-35--Owner Inspection and Services, Chart B



| FREQUENCY  | INSPECTION OR SERVICE                  | WHAT TO DO   |
|--|--|--|
| <b>EACH TIME OIL IS CHANGED (WHEN VEHICLE IS ON HOIST)</b> | Tire and wheel inspection and rotation | Check tires for uneven or abnormal wear. Check for damaged wheels. To equalize wear and obtain maximum tire life, it is suggested that tires be rotated at about 5,000 miles (8 000 km) then each 15,000 miles (24 000 km) thereafter. See "Tires" in Owner's Manual. Section 5, for further information.<br><br>For dual wheels, whenever the truck, or wheels or fasteners are new, also have the wheel fastener torque set at the first 100, 1,000 and 5,000 miles (160, 1 600 and 8 000 km).   |
|  | Brake systems inspection               | For convenience the following should be done when wheels are removed for rotation: Inspect lines and hoses for proper hookup, binding, leaks, cracks, chafing etc. Inspect disc brake pads for wear and rotors for surface condition. Also inspect drum brake linings for wear and cracks. Inspect other brake parts, including drums, wheel cylinders, parking brake, etc. at the same time. Check parking brake adjustment.<br><br><b>INSPECT BRAKES MORE OFTEN IF HABIT OR CONDITIONS RESULT IN FREQUENT BRAKING.</b>   |
|  | Steering and suspension inspection     | Inspect front and rear suspension and steering system for damaged, loose or missing parts, signs of wear or lack of lubrication. Inspect power steering lines and hoses for proper hookup, binding, leaks, cracks, chafing, etc. On vehicles equipped with manual steering gear, check for seal leakage. Inspect final drive axle output shaft seals for leaking.  |
|  | Exhaust system inspection*             | Inspect complete system Inspect body near the exhaust system. Look for broken, damaged, missing or out-of-position parts as well as open seams, holes, loose connections or other conditions which could cause a heat build up in the floor pan or could let exhaust fumes seep into the passenger compartment.  |
|  | Throttle linkage inspection            | Inspect for damaged or missing parts, interference or binding.   |
|  | Engine drive belts                     | Inspect all belts for cracks, fraying and wear. Adjust or replace as needed.   |
|  | Rear axle/front axle/transfer case     | Check fluid level and add if needed.<br><ul style="list-style-type: none"> <li>● Locking Differential in vehicles less than 8600# GVW - In general service, drain fluid at 5000 miles (8 000 km) and refill. Check fluid level and add as needed at subsequent 5000 mile (8 000 km) intervals. In severe operating conditions, or trailer towing applications, drain fluid every 5000 miles (8 000 km) and refill.</li> <li>● Locking Differential in vehicles of 8600# GVW and above - In general service, drain fluid at 5000 miles (8 000 km) and refill. Change fluid at 10,000 mile (16 000 km) intervals and check fluid and add as needed at 5000 mile (8 000 km) intervals thereafter. In severe operating conditions, or trailers towing applications, drain fluid every 5000 miles (8 000 km) and refill as specified.</li> <li>● Standard Differential in vehicles less than 8600 # GVW - In general service, check fluid level and add as needed every 5000 miles (8 000 km). In severe operating conditions, or trailer towing applications, drain fluid every 5,000 miles ( 8 000 km) and refill as specified.</li> <li>● Standard Differential in vehicles of 8600 # GVW and above - In general service, drain fluid every 25,000 miles (40 000 km) and refill. Check fluid level and add as needed at 5000 mile (8 000 km) intervals. In severe operating conditions, or trailer towing applications, drain fluid every 10,000 miles (16 000 km) and refill.</li> <li>● <b>Four Wheel Drive</b> — Every 12 months or 5000 miles (8 000 km), check front axle and transfer case and add lubricant when necessary. Lubricate propeller shaft slip joint, constant velocity universal joint and steering linkage. Oil control lever pivot point and exposed control linkage. Check vent hose at front axle transfer case for kinks and proper installation. More frequent lubrication may be required on heavy duty off-road operation. See Owner's and Driver's Manual for further information.</li> </ul> |
|  | Manual transmission                    | Check fluid level and add as required  |

Fig. 0B-36--Owner Inspection and Services, Chart C

| USAGE  | FLUID/LUBRICANT  |
|--|--|
| Engine Oil   | SF CD* or SF CC* Engine Oil  |
| Engine Coolant   | Mixture of water and a high quality Ethylene Glycol base type antifreeze conforming to GM spec. 1825-M (GM Part No. 1052753) or equivalent |
| Brake System   | Delco Supreme 11 fluid or DOT-3  |
| Parking Brake Cables   | Chassis grease meeting requirements of GM spec. 6031-M   |
| Power Steering System  | GM power steering fluid Part No. 1050017 or equivalent   |
| Manual Steering Gear   | Lubricant GM Part No. 1051052 or equivalent  |
| Automatic Transmission<br>4-Speed Manual Trans. w/O D.<br>S10 Truck with Manual Trans.<br>Transfer Case  | DEXRON® II Automatic Transmission Fluid  |
| Differential—Standard or Manual Transmission<br>(Except: 4-Speed with O.D., and S10 Truck)   | SAE-80W, GL-5 or SAE-80W-90 GL-5 gear lubricant (SAE-80W—GL-5 in Canada)   |
| Differential—Locking   | Lubricant GM Part No. 1052271  |
| Manual Transmission Shift Linkage, Column Shift, Propeller Shaft Slip Joint  | Chassis grease meeting requirements of GM spec. 6031-M   |
| Key Lock Cylinders   | WD-40 Spray Lubricant or equivalent  |
| Clutch Linkage (Man. Trans. only)<br>a. Pivot points<br>b. Push rod to clutch fork joint, and cross shaft pressure fitting                                       | a. Engine oil<br>b. Chassis grease meeting requirements of GM spec. 6031-M   |
| Chassis Lubrication  | Chassis grease meeting requirements of GM spec. 6031-M   |
| Windshield Washer Solvent  | GM Optikleen washer solvent Part No. 1051515 or equivalent   |
| Hood Latch Assembly<br>a. Pivots and spring anchor<br>b. Release pawl  | a. Engine oil<br>b. Chassis grease   |
| Front Wheel Bearings   | Lubricant GM Part No. 1051344 (one pound) or equivalent*   |
| Constant Velocity Universal Joint  | GM Lubricant Part No. 1052497 or equivalent  |
| Automatic Transmission Shift Linkage, Floor Shift Linkage, Hood and Door hinges, body door hinge pins, tailgate hinge and linkage, folding seat, fuel door hinge | Engine Oil   |

\* Fluids and lubricants identified with GM part numbers or GM specification numbers may be obtained from your GM dealer.

Fig. OB-37--Recommended Fluids Lubricants

# SECTION 1A

## HEATER

### CONTENTS

|                        |       |
|------------------------|-------|
| Standard Heater.....   | 1A-1  |
| Auxiliary Heater ..... | 1A-15 |
| Specifications .....   | 1A-20 |

## STANDARD HEATER

### INDEX

|   |      |                               |       |
|---|------|-------------------------------|-------|
| General Description.....                  | 1A-1 | Heater Hoses .....            | 1A-9  |
| System Components .....                   | 1A-1 | Center Distributor Duct ..... | 1A-9  |
| System Controls .....                     | 1A-1 | Defroster Duct.....           | 1A-9  |
| Diagnosis.....                            | 1A-4 | Control Assembly.....         | 1A-9  |
| On Vehicle Service                        |      | Control Cables.....           | 1A-11 |
| Blower Motor.....                         | 1A-8 | Blower Switch.....            | 1A-11 |
| Heater Distributor and Core Assembly..... | 1A-8 | Resistor Unit .....           | 1A-11 |

## GENERAL DESCRIPTION

Heating components are attached to the dash panel on the right side of the vehicle. The blower and air inlet assembly and water hoses are located on the forward side of the dash panel while the heater core and distributor duct are on the passenger side.

The heater system is an air mix type system in which outside air is heated and then mixed in varying amounts with cooler outside air to attain the desired air temperature. The system consists basically of three parts: (1) the blower and air inlet assembly, (2) the heater distributor assembly and (3) the heater control assembly.

### HEATER AIR FLOW SCHEMATIC

C-K Series heater airflow is shown in Fig. 1A-1.

### BLOWER AND AIR INLET ASSEMBLY

The blower and air inlet assembly draws outside air through the outside air inlet grille located forward of the windshield reveal molding and channels the air into the heater distributor assembly. The operation of the blower motor is controlled by the FAN switch on the heater control. The motor is connected in series with the FAN switch and also the blower resistor assembly.

### HEATER DISTRIBUTOR ASSEMBLY

The heater distributor assembly houses the heater core and the doors necessary to control mixing and channeling of

the air. Since the unit has no water valve, water circulation keeps the core hot at all times. That portion of the air passing through the core receives maximum heat from the core. Air entering the distributor assembly is channeled as follows:

#### C-K Models

Air entering the distributor can be directed out the purge door opening, on the right end of the distributor assembly, by the purge door. If the purge door is closed, then air is directed through and/or around the heater core by the temperature door. Air is then directed into the passenger compartment through the heater (floor) outlets and/or the defroster (dash) outlets by the defroster door. The temperature of the outlet air is dependent on the ratio of heated to unheated air (controlled by the temperature door).

#### G Models

Air flow is controlled by doors in the distributor assembly. The air door can be adjusted to vary airflow. If air is allowed to enter the distributor assembly, it is then directed through and/or around the heater core by the temperature door. Air is directed into the passenger compartment through the heater (floor) and/or defroster (dash) outlets by the defroster door. The temperature of the outlet air is dependent of the ratio of heated to unheated air (controlled by the temperature door).

### CONTROLS

Heater controls for C-K and G Models are shown in Fig. 1A-2.

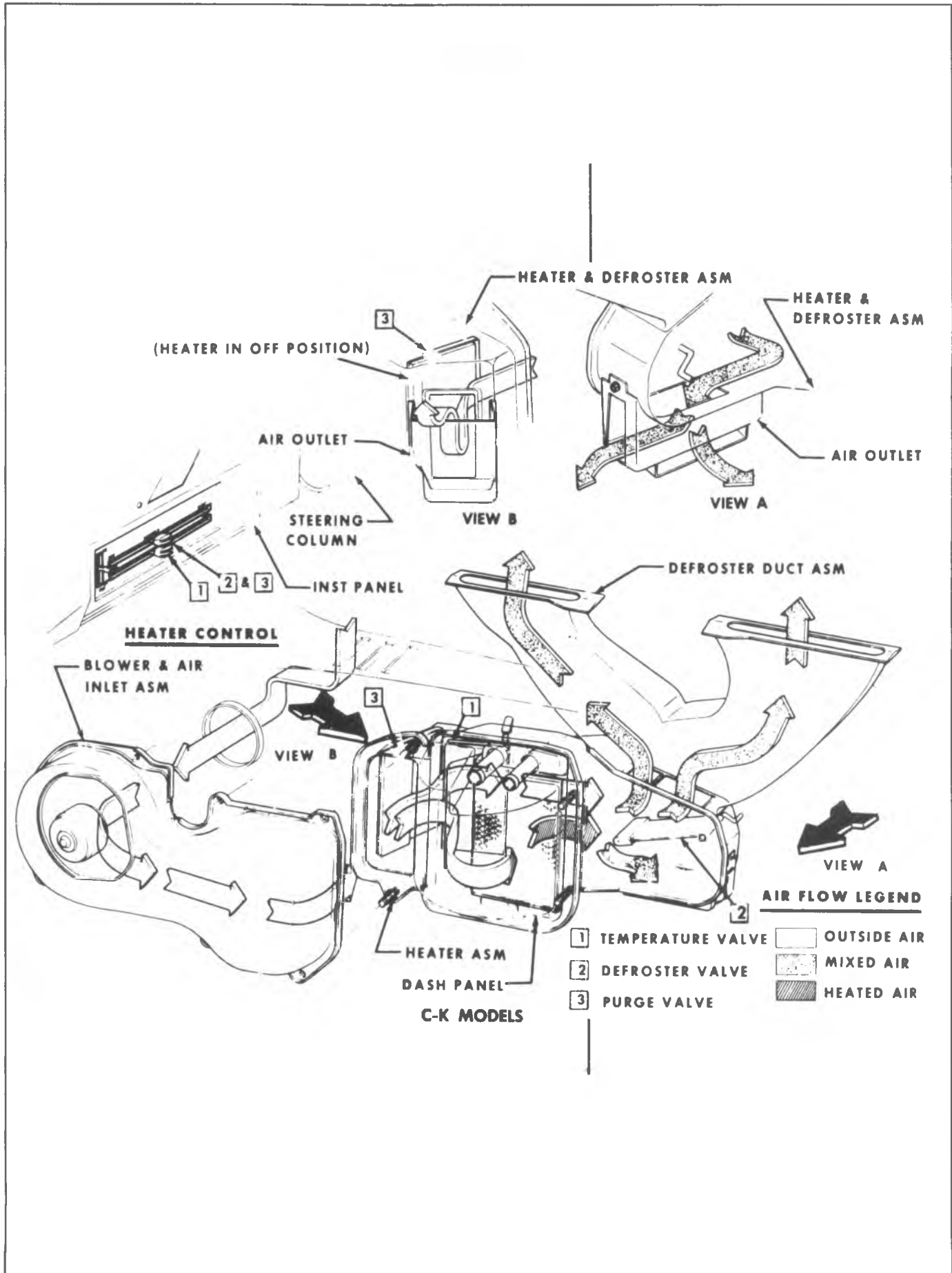

Fig. 1A-1--Heater Air Flow Schematic--C-K Models

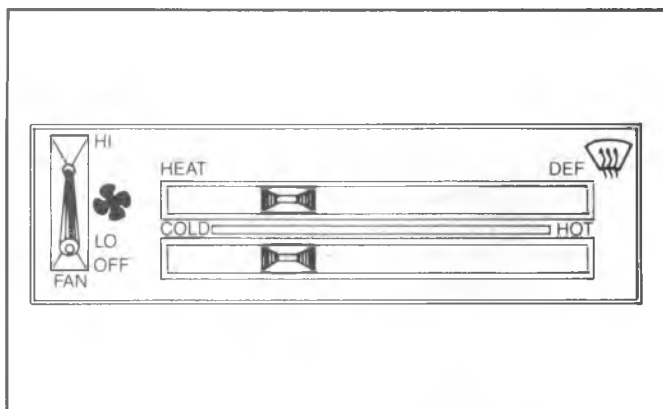

Fig. 1A-2--Heater Control-C-K Models

## DIAGNOSIS

| TROUBLE  | CAUSE AND CORRECTION  |
|--|---|
| Temperature of heater air at outlets too low to heat up passenger compartment.                   | 1. See "Insufficient Heat Diagnostic Chart".  |
| Temperature of heater air at outlets adequate but the vehicle will not build up sufficient heat. | <p>Check for body leaks such as:</p> <ol style="list-style-type: none"> <li>1. Floor side kick pad ventilators partially open.</li> <li>2. Leaking grommets in dash.</li> <li>3. Leaking welded seams along rocker panel and windshield.</li> <li>4. Leaks through access holes and screw holes.</li> <li>5. Leaking rubber molding around door and windows.</li> <li>6. Leaks between sealing edge of blower and air inlet assembly and dash, and between sealing edge of heater distributor assembly and dash.</li> </ol>   |
| Inadequate defrosting action.  | <ol style="list-style-type: none"> <li>1. Check that DEFROST lever completely opens defroster door in DEF position - Adjust if necessary.</li> <li>2. Insure that temperature and air doors open fully - Adjust.</li> <li>3. Look for obstructions in defroster ducts - Remove any obstructions.</li> <li>4. Check for air leak in ducting between defroster outlet on heater assembly and defroster duct under instrument panel - Seal area as necessary.</li> <li>5. Check position of bottom of nozzle to heater locating tab - Adjust.</li> <li>6. Check position of defroster nozzle openings relative to instrument panel openings. Mounting tabs provide positive position if properly installed.</li> </ol> |
| Inadequate circulation of heated air through vehicle.  | <ol style="list-style-type: none"> <li>1. Check heater air outlet for correct installation - Reinstall.</li> <li>2. Inspect floor carpet to insure that carpet lies flat under front seat and does not obstruct air flow under seat, and also inspect around outlet ducts to insure that carpet is well fastened to floor to prevent cupping of air flow - Correct as necessary.</li> </ol>   |
| Erratic heater operation.  | <ol style="list-style-type: none"> <li>1. Check coolant level - Fill to proper level.</li> <li>2. Check for kinked heater hoses - relieve kinks or replace hoses.</li> <li>3. Check operation of all bowden cables and doors - Adjust as necessary.</li> <li>4. Sediment in heater lines and radiator causing engine thermostat to stick open - flush system and clean or replace thermostat as necessary.</li> <li>5. Partially plugged heater core - backflush core as necessary.</li> </ol>  |
| Hard operating or broken controls.   | <ol style="list-style-type: none"> <li>1. Check for loose bowden cable tab screws or mis-adjusted bowden cables - Correct as required.</li> <li>2. Check for sticking heater system door(s) - Lubricate as required using a silicone spray.</li> </ol>  |

INSUFFICIENT HEAT DIAGNOSIS

Position the controls so that the:  
 Temperature lever is on full heat.  
 Selector or heater lever is on Heater.  
 Fan switch is on Hi.

\*CHECK DUMP DOOR OUTLET FOR AIR FLOW

NO AIR FLOW

CHECK DEFROSTER OUTLETS FOR AIR FLOW  
 (If in doubt as to High or Low air flow set selector on DEF which is High and compare. Reset selector on Heater)

NO OR LOW AIR FLOW

CHECK HEATER OUTLET AIR FLOW  
 (If in doubt, switch fan switch from Hi to Lo)

CHANGE IN AIR FLOW

NORMAL AIR FLOW

Check heater outlet temperature with 220° F range thermometer.

(approximate outlet air temperatures)

|             |     |     |     |     |
|-------------|-----|-----|-----|-----|
| Outlet Air  | 145 | 150 | 155 | 165 |
| Ambient Air | 0   | 25  | 40  | 75  |

NORMAL TEMPERATURE

Remove all obstructions under front seat.  
 Car does not build up heat - operate vent controls and see that the air vent doors close completely, if not, adjust.

LOW TEMPERATURE

(Check the system temperature after repairing the item checked to complete the diagnosis.)  
 Check coolant level; if low, fill. Look for or feel all radiator and heater hoses and connections for leaks. Repair or replace. Check the radiator cap for damage and replace if required.  
 Check heater and radiator hoses for kinks - straighten and replace as necessary.  
 Check temperature door for max heat position. Adjust if necessary.

HEATER CORE

Feel temperatures of heater inlet and outlet hoses.

WARM INLET AND OUTLET HOSES

Check engine thermostat.

HOT INLET AND WARM OUTLET HOSES

Check pulleys, belt tension, etc., for proper operation. Replace or service as necessary.

Remove hoses from heater core. Reverse flush with tap water. If plugged, repair or replace.

AIR FLOW

Adjust dump door for no air flow.

HIGH AIR FLOW

Adjust defroster door for low air flow.

LITTLE OR NO CHANGE IN AIR FLOW

LOW OR NO AIR FLOW

\*\*Check shutoff door position for full system air flow. Adjust if necessary.

LOW AIR FLOW

Check heater outlet for obstruction - remove.  
 Check motor voltage at closest motor line connection with a voltmeter.

UNDER 10 VOLTS

Check battery volts - under 10 volts, recharge then recheck motor voltage.  
 Check wiring and connections for under 10 volts from motor to fan switch. Repair or replace last point of under 10 volt reading.

Apply external ground, (jumper wire) to motor case. INCREASED AIR FLOW - repair ground.

SAME AIR FLOW - remove motor and check for obstruction in system opening. If none, REPLACE MOTOR. If obstruction, remove material and re-install motor.

OVER 10 VOLTS

NO AIR FLOW

CHECK FUSE

FUSE BLOWN - replace fuse.  
 AIR FLOW - system okay.

BLOWS FUSE

Remove positive lead from motor and replace fuse.  
 FUSE REMAINS OK - remove motor and check for obstruction in system opening, if none, REPLACE MOTOR. If obstruction, remove material and re-install motor.  
 BLOWS FUSE - check for shorted wire in blower electric circuit - See Heater Circuit Diagnostic Chart.

FUSE OK

FUSE OK - See Heater Circuit Diagnostic Chart.

\*CHECK FOR C-K MODELS ONLY

\*\*CHECK FOR G MODELS ONLY

### HEATER CIRCUIT DIAGNOSIS\*

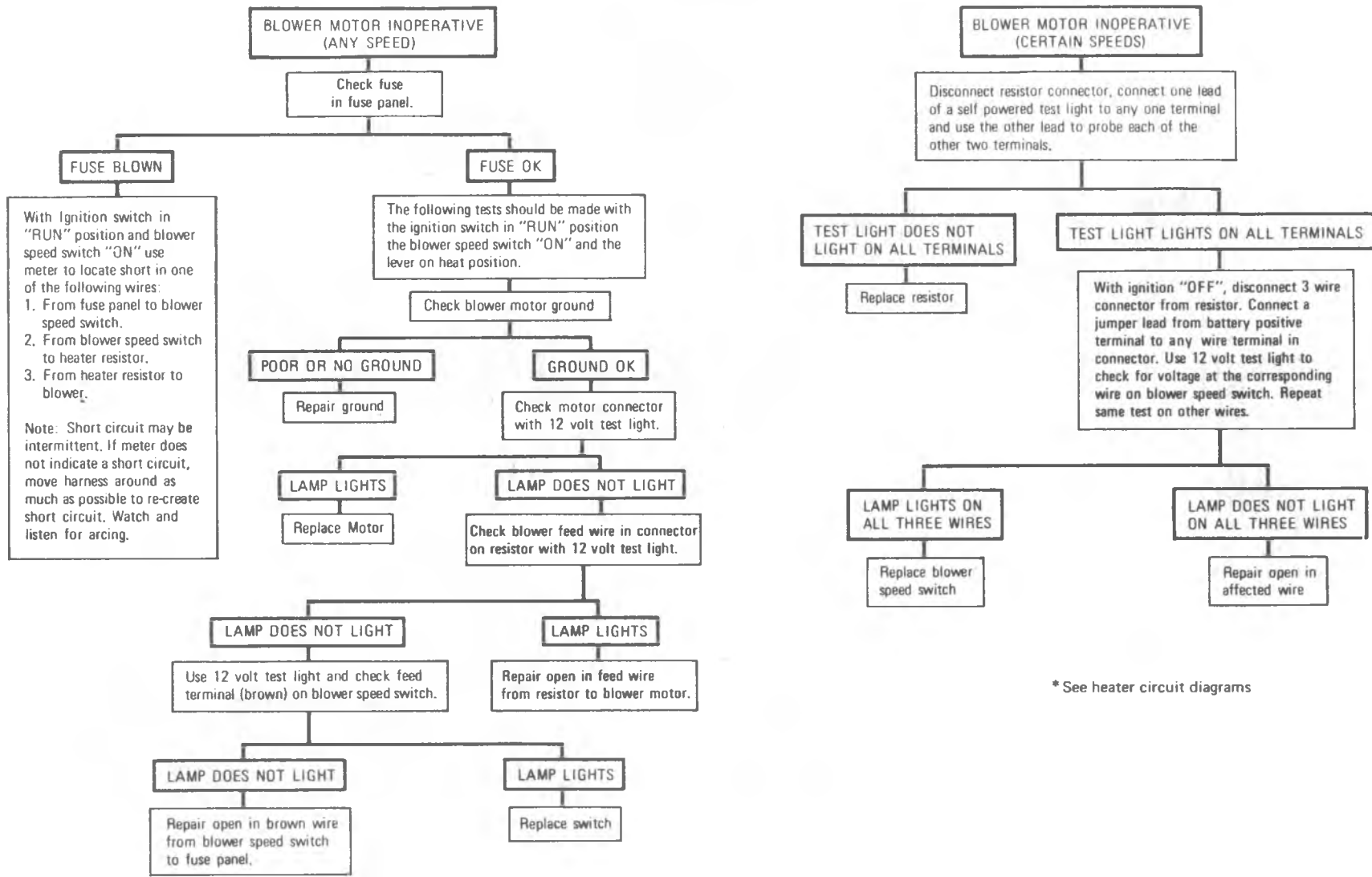

\* See heater circuit diagrams



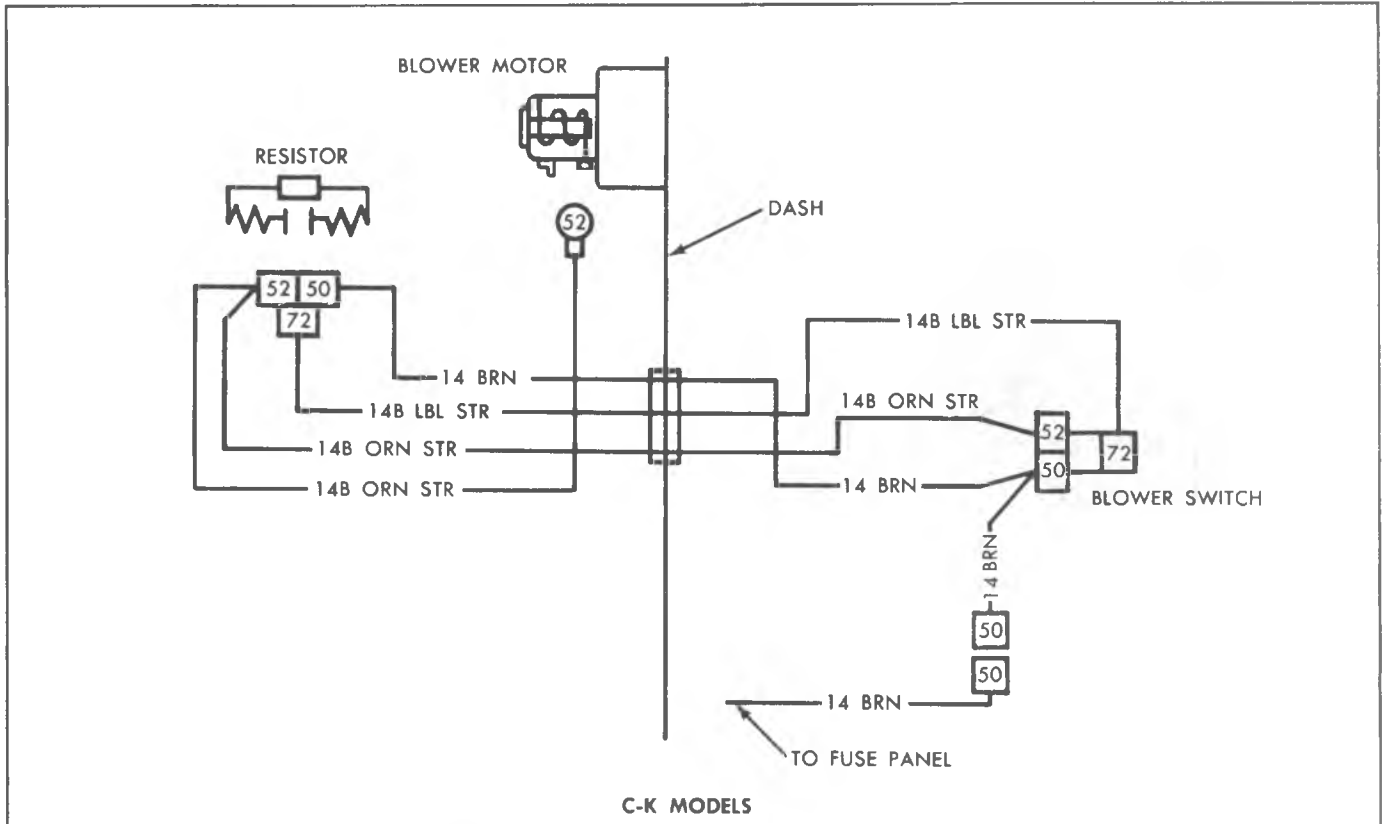

|     | CIRCUIT  |
|-----|----------|
| OFF | BAT-ONLY |
| LO  | BAT-LO   |
| MED | BAT-MED  |
| HI  | BAT-HI   |

|     | HEATER OPERATION                     |
|-----|--------------------------------------|
| LO  | BAT-BLO SW-RES R1 R2-<br>BLO MTR-GRD |
| MED | BAT-BLO SW-RES R1-<br>BLO MTR-GRD    |
| HI  | BAT-BLO SW-<br>BLO MTR-GRD           |

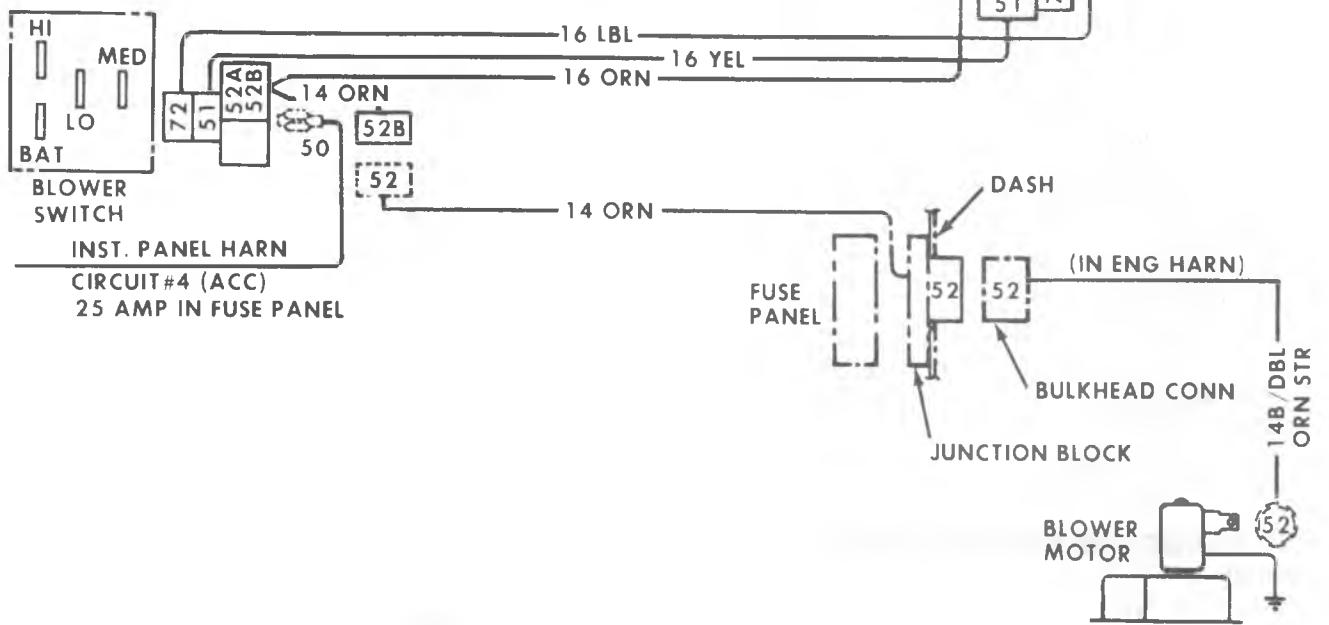
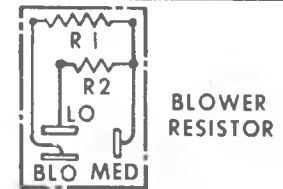

Fig. 1A-4--Heater Wiring Diagrams

## ON VEHICLE SERVICE

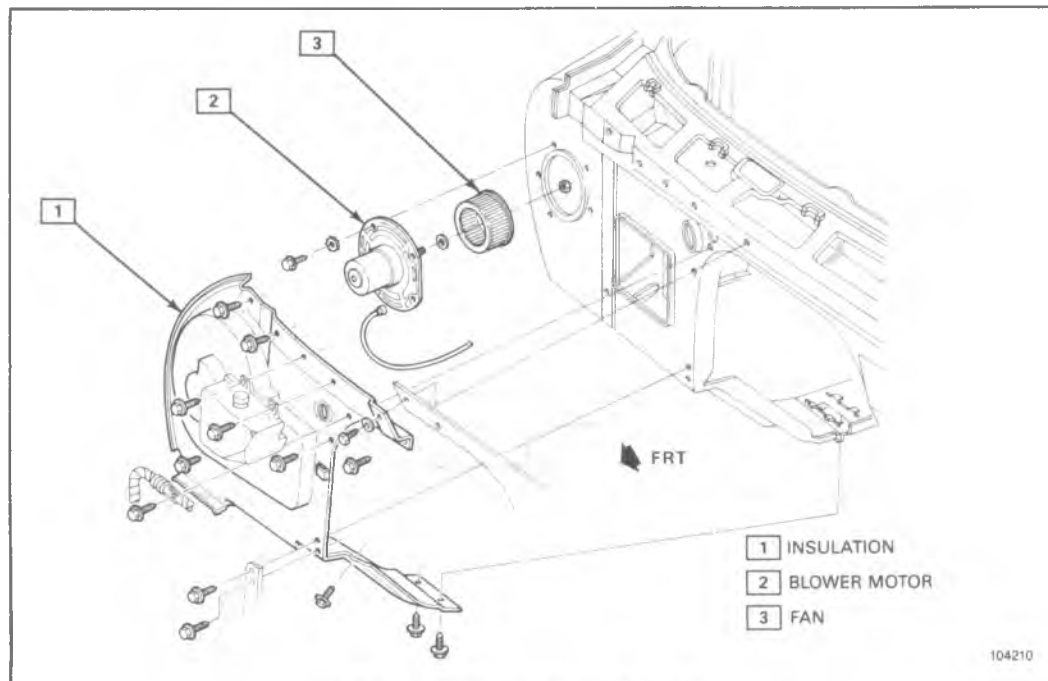

Fig. 1A-5-Blower Motor Assembly

**BLOWER MOTOR****Removal (Fig. 1A-5)**

1. Disconnect battery ground cable.  
**G Models** - Remove the coolant recovery tank, and power antenna as outlined in Sections 6 and 9.
2. Disconnect the blower motor lead wire.
3. Remove the five blower motor mounting screws and remove the motor and wheel assembly. Pry gently on the blower flange if the sealer acts as an adhesive.
4. Remove the blower wheel to motor shaft nut and separate the wheel and motor assemblies.
5. To install a new motor, reverse Steps 1-4 above.  
 The following steps should be taken to assure proper installation:
  - a. Assemble the blower wheel to the motor with the open end of the wheel away from the blower motor.
  - b. If the motor mounting flange sealer has hardened, or is not intact, remove the old sealer and apply a new bead of sealer to the entire circumference of the mounting flange.
  - c. Check blower operations: blower wheel should rotate freely with no interference.

**HEATER DISTRIBUTOR AND CORE ASSEMBLY****C-K Models****Replacement (Fig. 1A-6)**

1. Disconnect the battery ground cable.
2. Disconnect the heater hoses at the core tubes and drain engine coolant into a clean pan. Plug the core tubes to prevent coolant spillage at removal.

3. Remove the nuts from the distributor duct studs projecting into the engine compartment.
4. Remove the glove box and door assembly.
5. Disconnect the Air-Defrost and Temperature door cables.
6. Remove the floor outlet and remove the defroster duct to heater distributor duct screw.
7. Remove the heater distributor to dash panel screws. Pull the assembly rearward to gain access to wiring harness and disconnect all harnesses attached to the unit.
8. Remove the heater-distributor from the vehicle.
9. Remove the core retaining straps and remove the core.
10. To install, reverse Steps 1-9 above. Be sure core to case and case to dash panel sealer is intact before assembling unit.

**G Models****Replacement (Fig. 1A-7)**

1. Disconnect the battery ground cable.
2. Remove coolant recovery tank and lay aside.

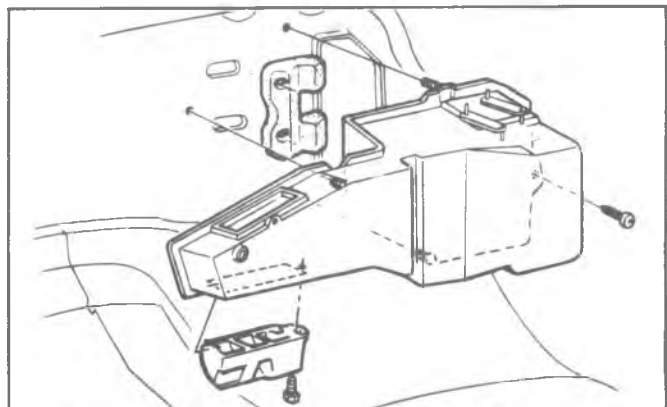

Fig. 1A-6-Heater Distributor Assembly--C-K Models

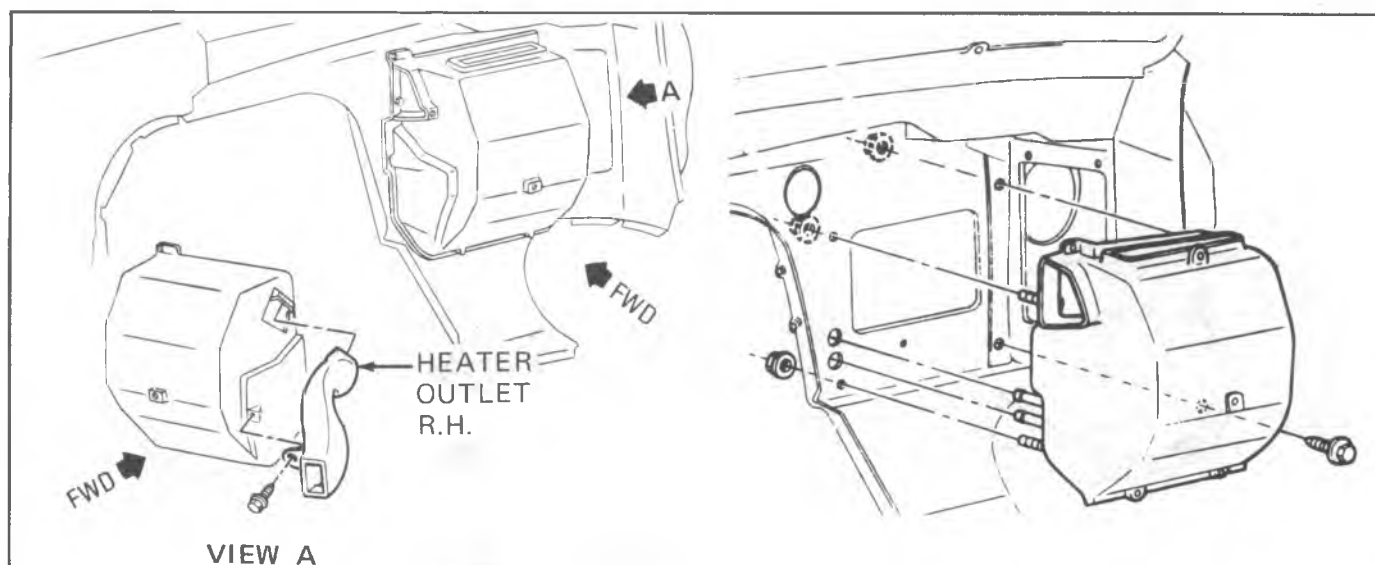

Fig. 1A-7--Heater Distributor - G Models

3. Place a clean pan under the vehicle and then disconnect the heater core inlet and outlet hoses at the core connections (see "Heater Hoses-Replacement" later in this section). Quickly plug the heater hoses and support them in a raised position. Allow the coolant in the heater core to drain into the pan on the floor.
4. Remove heater distributor duct to distributor case attaching screws and distributor duct to engine cover screw and remove duct.
5. Remove engine housing cover.
6. Remove instrument panel attaching screws: above, at windshield, all lower screws and right lower I.P. support bracket at door pillar and engine housing.
7. Lower steering column, and raise and support right side of I.P.
8. Remove defroster duct to distributor case attaching screw, and 2 screws attaching distributor to heater case.
9. Disconnect temperature door cable and fold cable back for access (Refer to Fig. 1A-17).
10. Remove three (3) nuts at engine compartment side of distributor case and one (1) screw on passenger side.
11. Remove the heater case and core as an assembly. Tilt the case assembly rearward at the top while lifting up until the core tubes clear the dash openings.
12. Remove the core retaining strap screws and remove the core.
13. To install a new core, reverse Steps 1-10 above. Be sure core to case and case to dash panel sealer is intact before assembling unit.

## HEATER HOSES

Heater hoses are routed from the thermostat housing or inlet manifold and water pump (radiator on some automatic transmission vehicles) to the core inlet and outlet pipes as shown in Figures 1A-8 thru 1A-11. Hoses are attached at each end with screw type clamps.

## Replacement

The heater core can be easily damaged in the area of the core tube attachment seams whenever undue force is exerted on them. Whenever the heater core hoses do not readily come off the tubes, the hoses should be cut just forward of the core tubes. The portion of the hose remaining on the core tube should then be split longitudinally. Once the hoses have been split, they can be removed from the tubes without damaging to the core.

## DISTRIBUTOR DUCTS - G Models

### Replacement (Fig. 1A-12)

1. Disconnect the battery ground cable.
2. Raise I.P. at right side as outlined under heater distributor removal.
3. Unsnap the engine cover front latches. Remove the two cover to floorpan screws and remove the cover.
4. Remove the heater distributor duct to case attaching screws as shown in Fig. 1A-12.
5. Remove one (1) screw at left center of distributor duct.
6. Pull the center distributor duct to the right and remove it from the vehicle.
7. To install, reverse Steps 1 thru 5. Check cable and door operation; cables should be free from kinks or binding and doors should close properly. If cable adjustment is necessary, refer to "Bowden Cable-Adjustment."

## DEFROSTER DUCT

Defroster assemblies attachment are shown in Fig. 1A-13.

## CONTROL ASSEMBLY

### C-K Models

### Replacement (Fig. 1A-14)

1. Disconnect the battery ground cable.
2. Remove the instrument panel bezel.
3. Disconnect the bowden cables and the blower switch

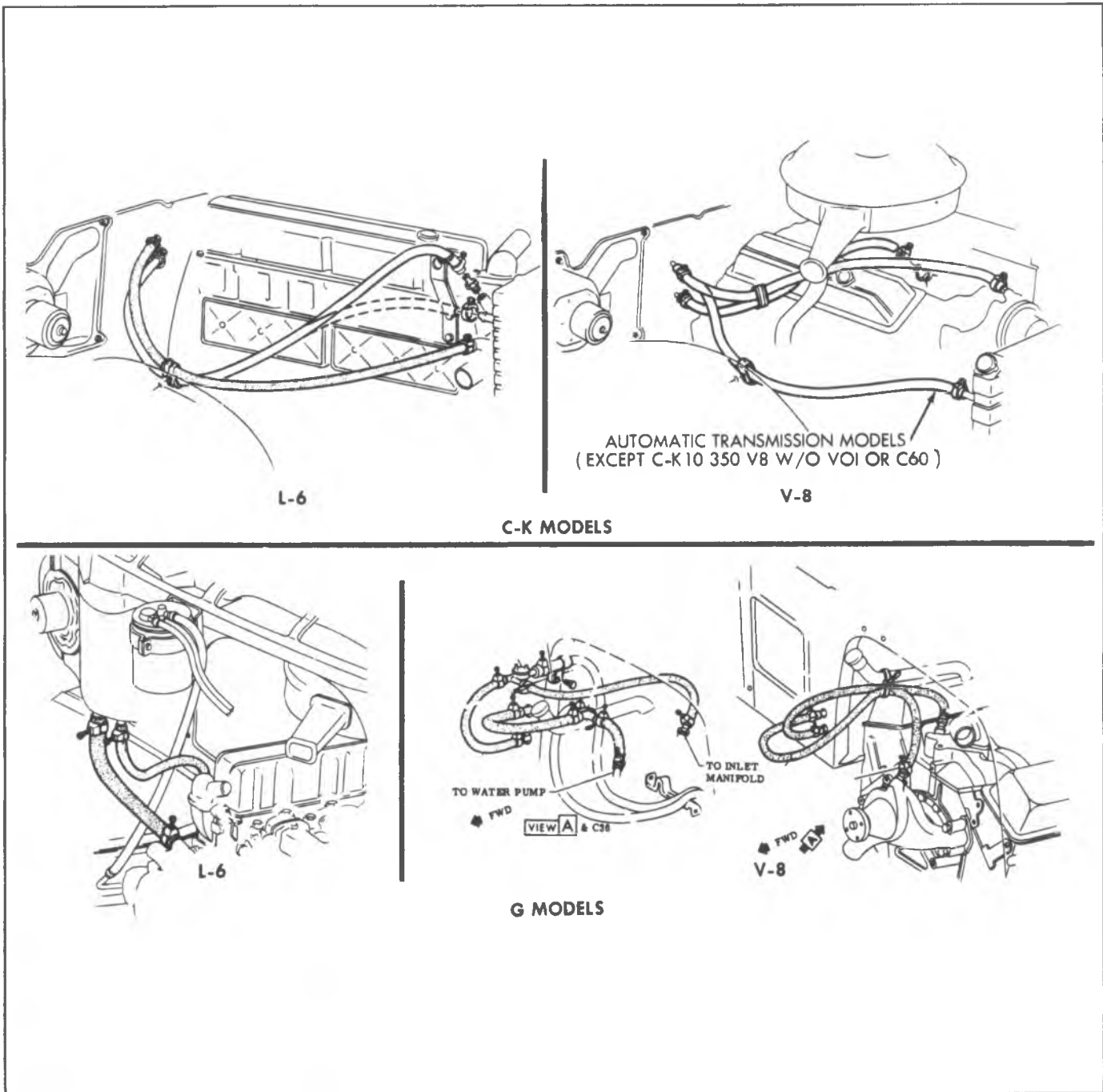

Fig. 1A-8--Heater Hose Routings

- wiring harness. Be careful not to kink the bowden cables.
- 4. Remove the control through the opening above the control.
- 5. If a new unit is being installed, transfer the blower switch to the new unit.
- 6. To reinstall, reverse Steps 1 thru 4.

**G Models**

**Replacement (Fig. 1A-15)**

- 1. Disconnect the battery ground cable.

- 2. Remove I.P. bezel as outlined in Section 8C of this manual.
- 3. Remove the control to instrument panel mounting screws (3) and carefully pull the control rearward far enough to gain access to the bowden cable attachments. Care should be taken to prevent kinking the bowden cables while lowering the control.
- 4. Disconnect the bowden cables, the control illumination bulb, the blower switch connector and remove the control from the vehicle.
- 5. Remove the blower switch screws and remove the blower switch.
- 6. To install, reverse Steps 1 thru 4.

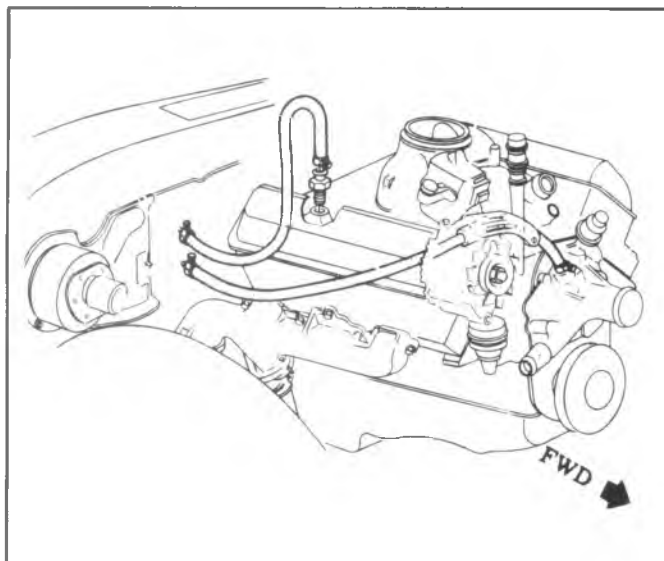

Fig. 1A-9--Heater Hose Routing-Diesel

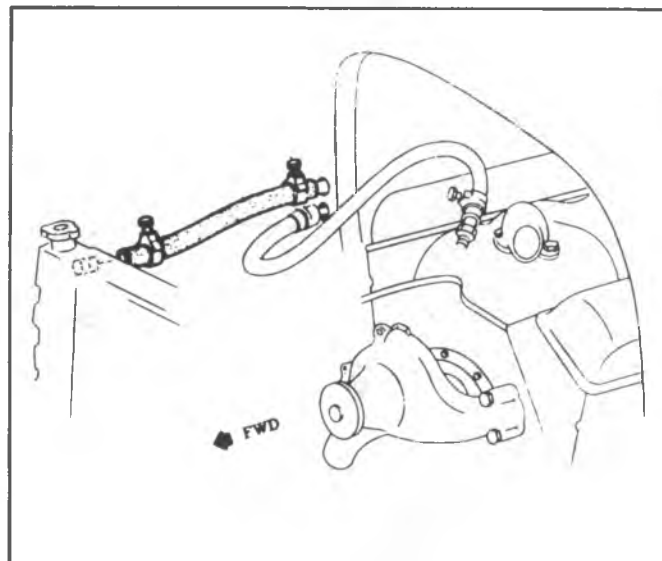

Fig. 1A-10--Heater Hose Routing V8

## CONTROL CABLES (Fig. 1A-16, 1A-17)

### C-K Models

#### Replacement

1. Disconnect the battery ground cable.
2. Remove the instrument panel bezel.
3. Remove the control to instrument panel screws.
4. Raise or lower control as necessary to remove cable push nuts and tab attaching screws.
5. Remove glove box and door as an assembly.
6. Remove cable push nut and tab attaching screw at door end of cable.
7. Remove cable from retaining clip and remove cable assembly.
8. To install, reverse Steps 1 thru 7. Be careful not to kink the cable during installation. Be sure to route the cable as when removed. Check cable adjustment.

### G Models

#### Replacement (Fig. 1A-17)

Heater and defroster cable routing and attachment to control and to distributor case is shown in Fig. 1A-17.

If cable adjustment is required, refer to Adjustment, C-K Series.

#### Adjustment - C-K Series

1. Disconnect the battery ground cable.
2. Remove glove box and door as an assembly.
3. Pry off the appropriate cable eyelet clip and disconnect the cable from the door.
4. Remove the cable retaining screw.
5. While holding the cable with pliers, rotate the mounting tab on the cable to lengthen or shorten the cable, whichever is required.

**NOTICE:** Do not pinch the cable too tightly or damage to the cable could result.

6. Install the cable, reversing Steps 1-4 above.

#### Adjustment - G Van

1. Attach inner cable and sheath to I.P. Control.
2. With I.P. installed, move temperature cable to cold and attach loop on inner cable to temperature door on heater case.
3. Attach cable sheath to heater case.
4. Move temperature lever to full heat. This will require some effort due to force required to slide inner cable clip to its proper position.

## BLOWER SWITCH

### C-K Models

#### Replacement (Fig. 1A-14)

1. Disconnect the battery ground cable.
2. Remove the instrument panel bezel.
3. Remove the control to instrument panel screws and lower the control onto the radio.
4. Disconnect the switch electrical harness.
5. Remove the switch attaching screws and remove the switch.
6. To install, reverse Steps 1-5 above.

### G Models

#### Replacement (Fig. 1A-15)

1. Disconnect the battery ground cable.
2. Disconnect the blower switch wiring harness connector at the switch.
3. Remove the two switch attaching screws and remove the switch assembly.
4. To install a new switch, reverse Steps 1 thru 3.

## RESISTOR

#### Replacement (Figs. 1A-5 and 1A-18)

1. Disconnect the wiring harness at the resistor connector.
2. Remove the two resistor mounting screws and remove the resistor.
3. To install a new resistor, reverse Steps 1 and 2 above.

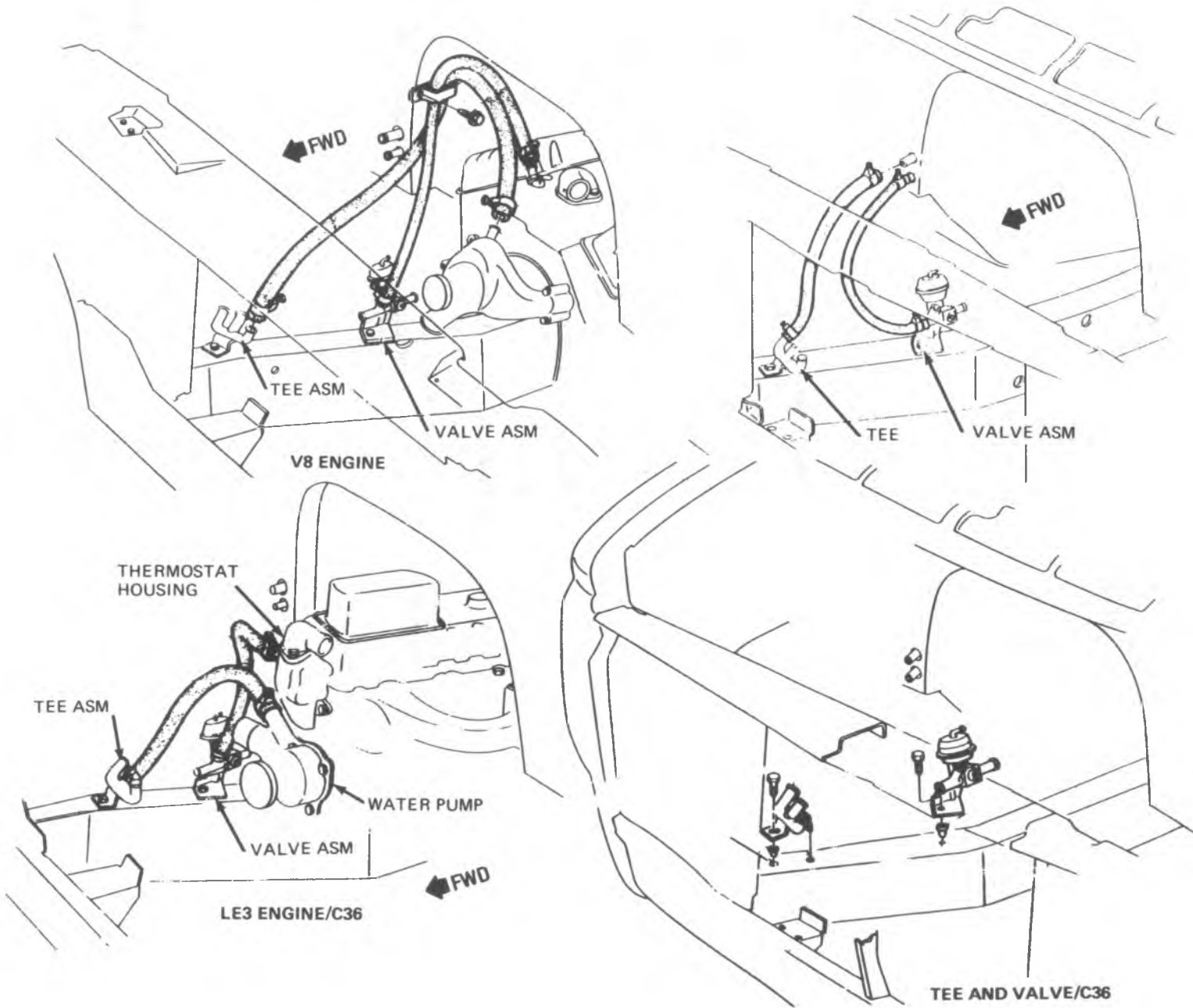

Fig. 1A-11-Heater Hose Routing G Series

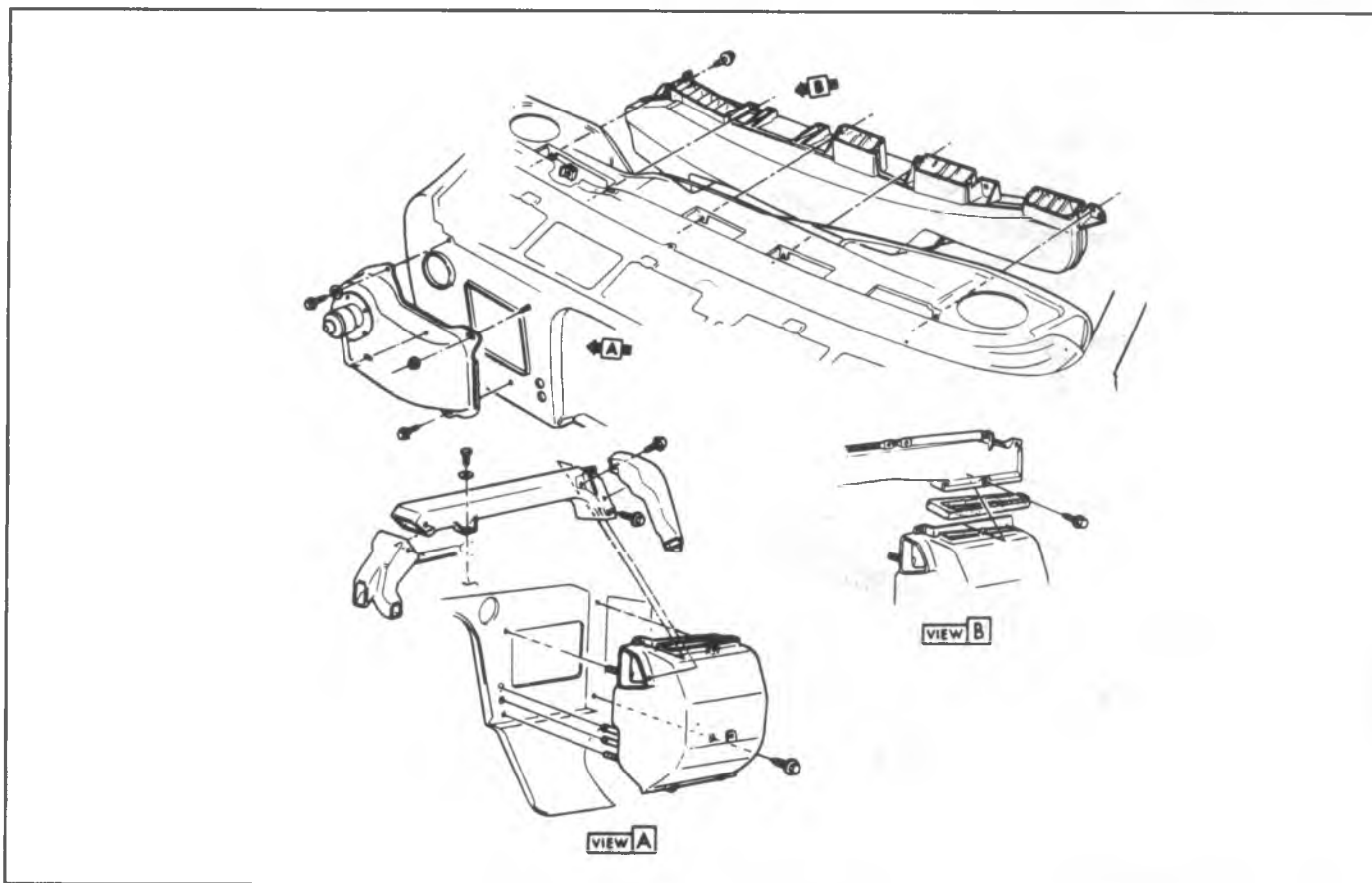

Fig. 1A-12--Distributor Ducts--G Models

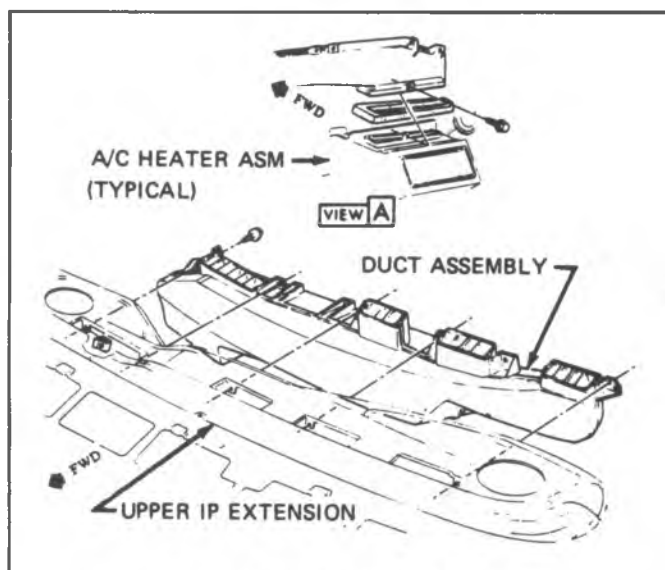

Fig. 1A-13--Defroster Outlets

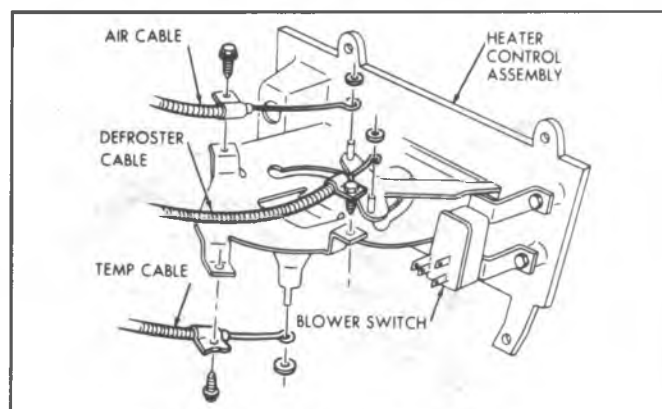

Fig. 1A-14--Control Assembly, C-K Models

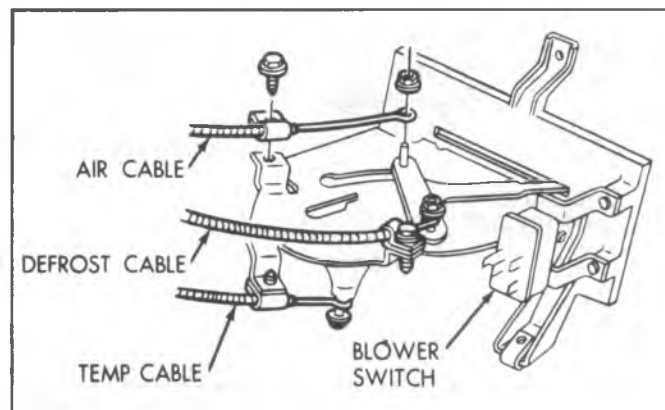

Fig. 1A-15--Control Assembly, G Models

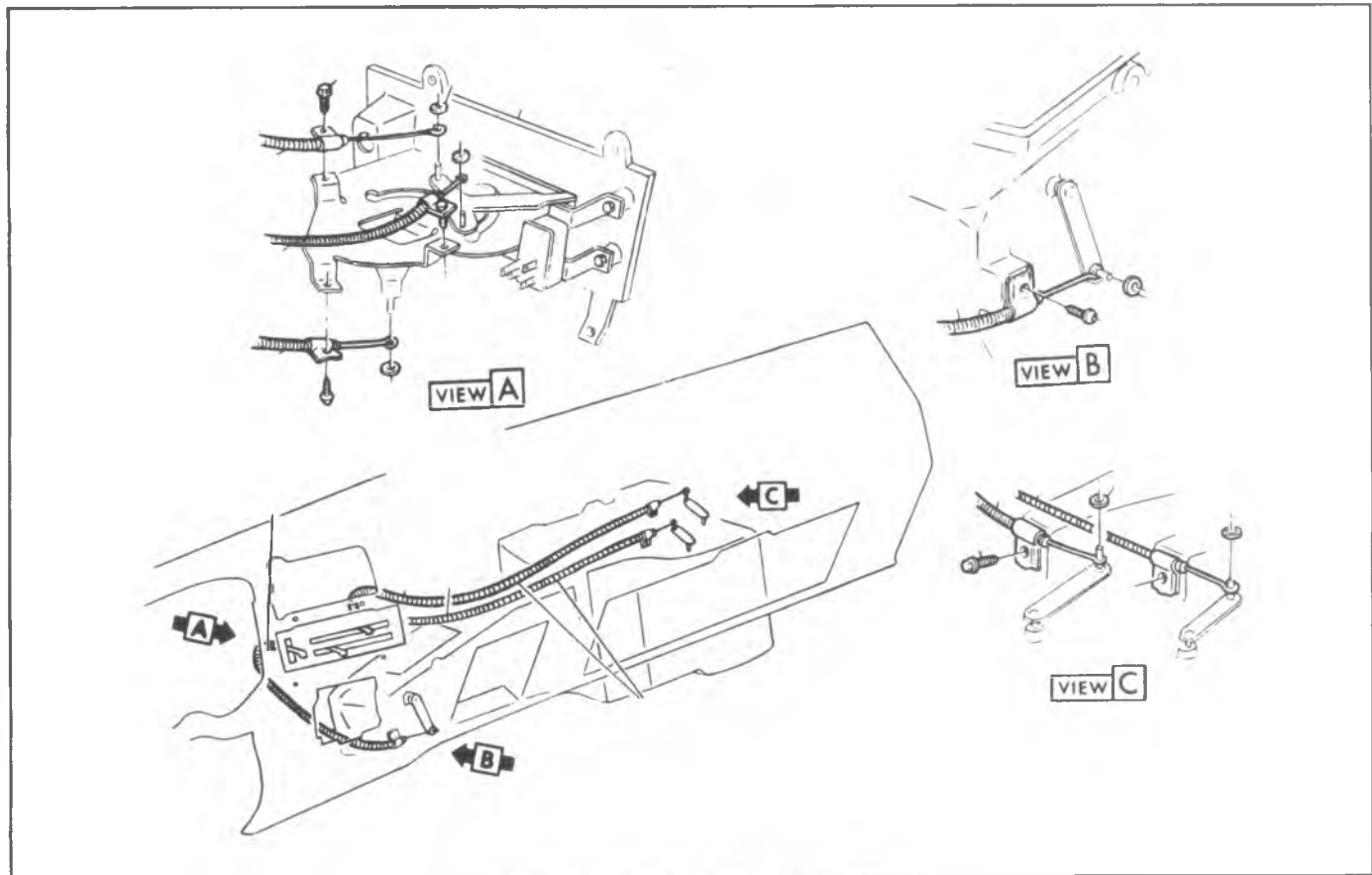

Fig. 1A-16--Control Cables, C-K Series

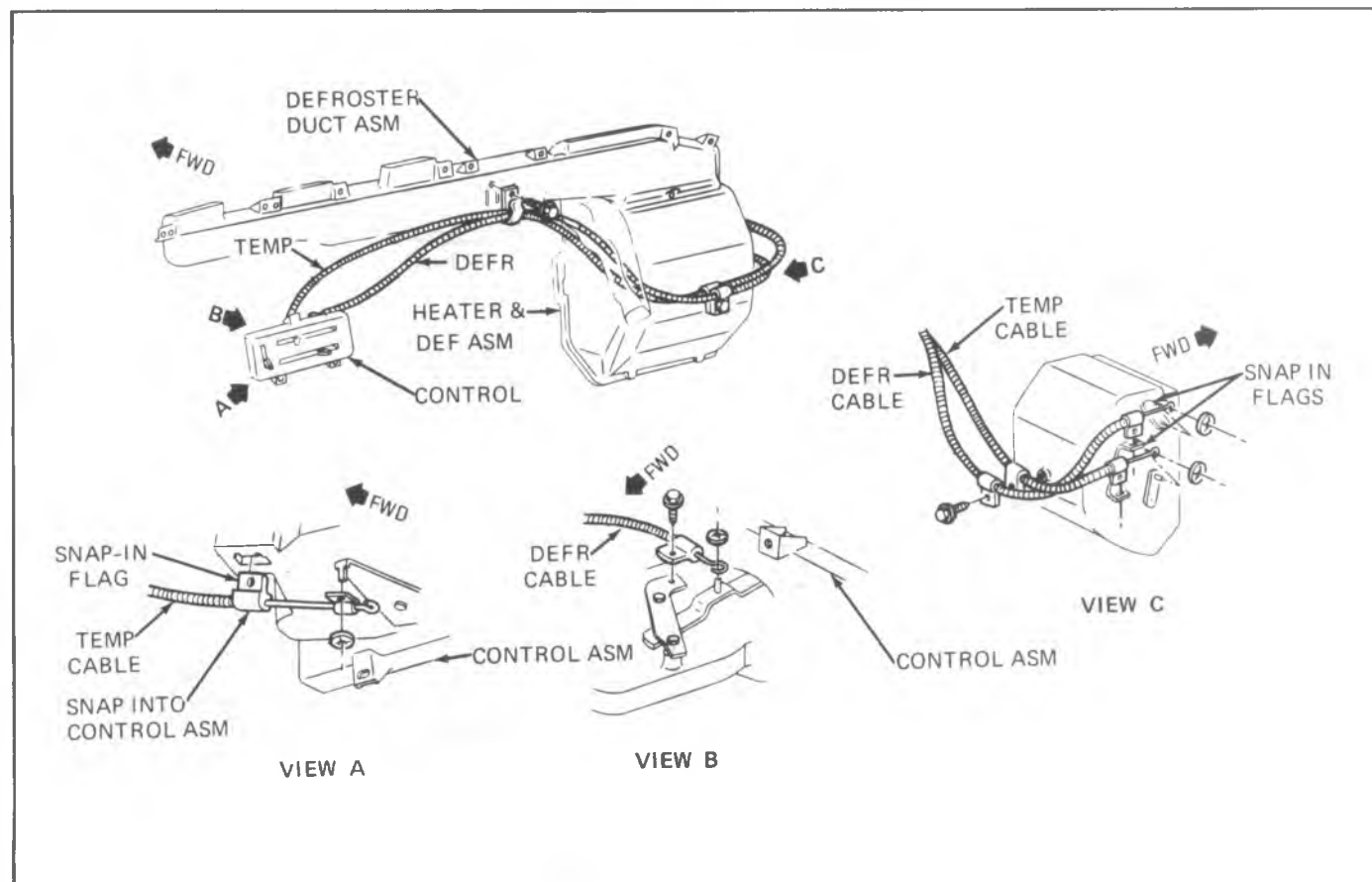

Fig. 1A-17--Control Cable Routing, G Models



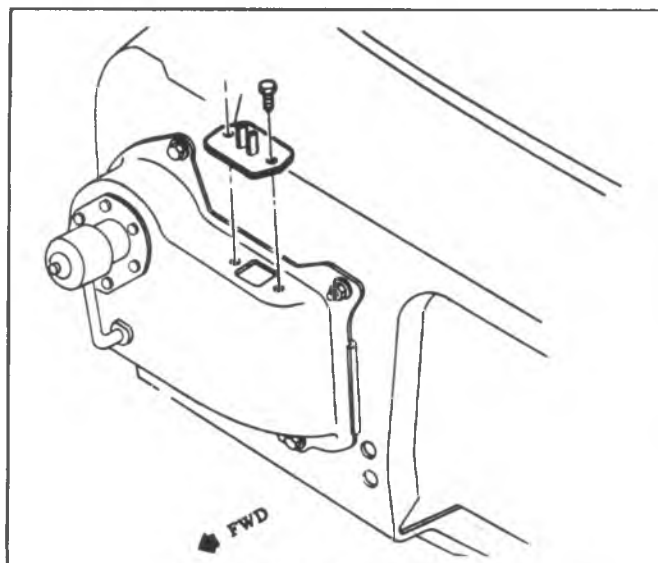

Fig. 1A-18--Resistor - G Models

## AUXILIARY HEATER

### INDEX

|                           |       |
|---------------------------|-------|
| General Description ..... | 1A-15 |
| Control .....             | 1A-15 |
| Diagnosis.....            | 1A-17 |
| On Vehicle Service.....   | 1A-18 |
| Specifications.....       | 1A-20 |

## GENERAL DESCRIPTION

An auxiliary heater is available accessory to provide additional heating capacity for the rearmost extremities of the certain modles.

This unit operates entirely independent of the standard heater and is regulated through its own controls at the instrument panel.

This system consists of a separate core and fan unit mounted as shown in Fig. 1A-19.

Heater hoses extend from the unit to the front of the vehicle where they are connected to the standard heater hoses with "tees". An "on-off" vacuum operated water valve is installed in the heater core inlet line in the engine compartment. The purpose of the valve is to cut off coolant flow to the auxiliary core during warm weather and eliminate the radiant heat that would result.

### CONTROLS

Two methods of control are employed with this system:

#### Water Valve (Refer Fig. 1A-11)

When heat is desired, and the fan switch is any position except off, a vacuum operated water valve controlled by the switch, opens the water line to permit hot water circulation through the heater core. In the OFF position the valve is closed to prevent unwanted heat during warm weather.

#### Fan Switch (Fig. 1A-20)

The three speed fan switch (LOW-MED-HI) is located in the instrument panel, to the right of the steering column.

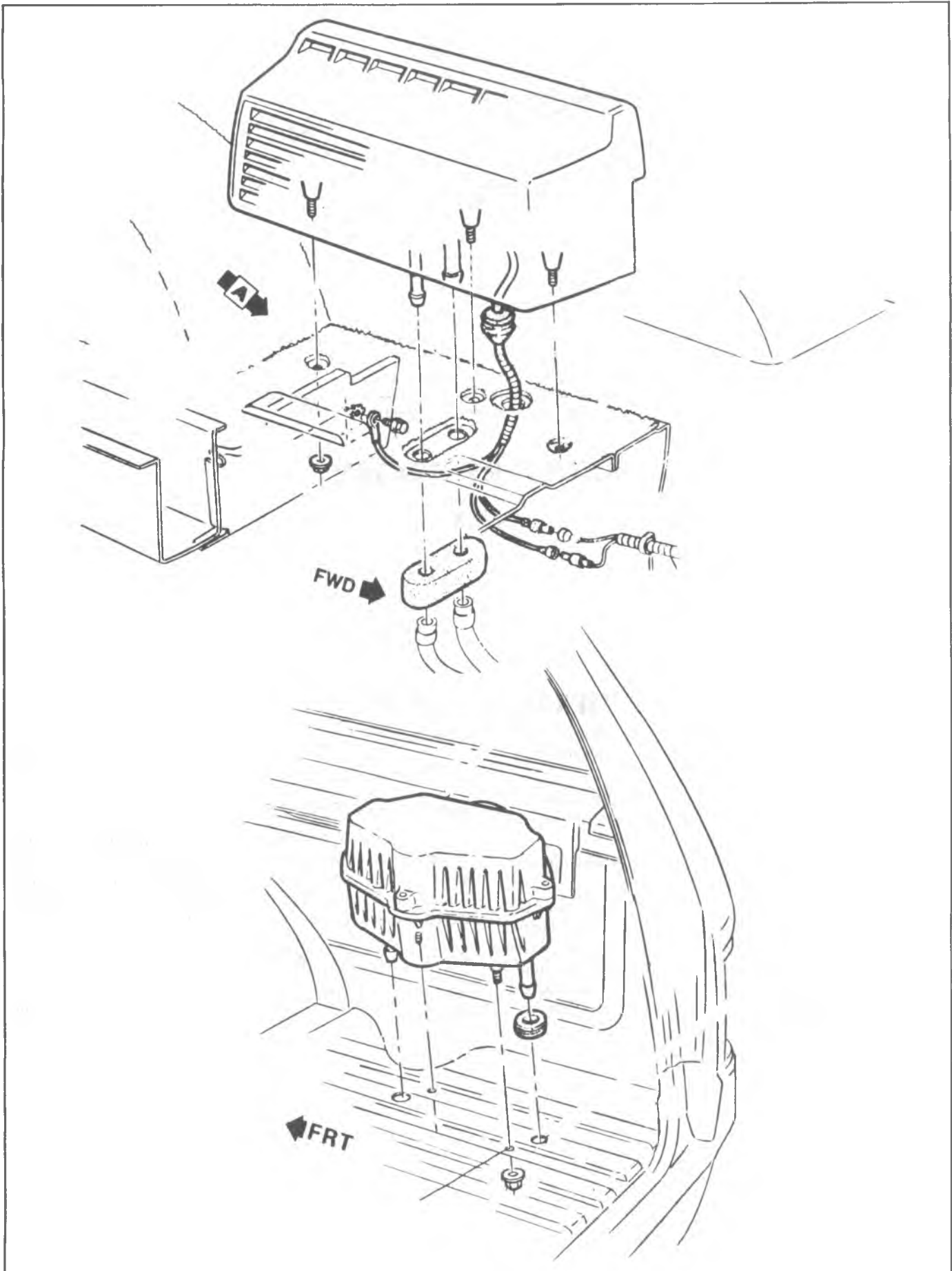

Fig. 1A-19--Auxiliary Heater Installation

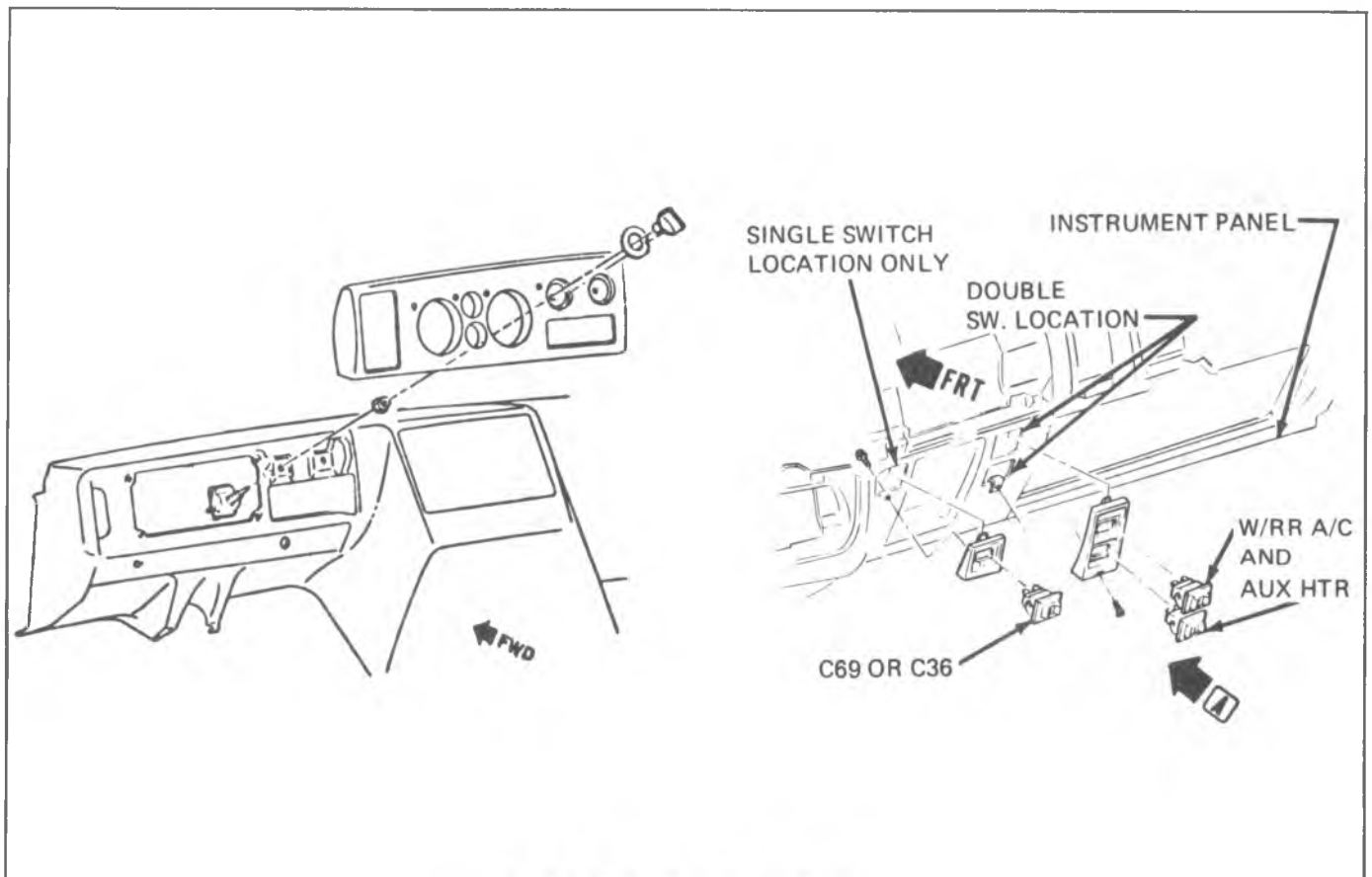

Fig. 1A-20--Auxiliary Heater Control

## DIAGNOSIS

Refer to the "Standard Heater" section of this manual for diagnostic information; Refer to Electrical Diagram Fig. 1A-21.

## SPECIFICATIONS

| <b>SECTION 1A</b>       |              |                         |                        |
|-------------------------|--------------|-------------------------|------------------------|
| <b>HEATER</b>           |              |                         |                        |
|                         | <u>Volts</u> | <u>Amps.<br/>(Cold)</u> | <u>RPM<br/>(Cold)</u>  |
| <b>Blower Motor</b>     |              |                         |                        |
| C-K Models . . . . .    | 13.5         | 6.25 Max.               | 2550 Min.<br>2950 Max. |
| G Models . . . . .      | 13.5         | 7.1 Max.                | 2850 Min.<br>3250 Max. |
| <b>Fuses</b>            |              |                         |                        |
| C-K Models . . . . .    |              |                         | 20 Amp.                |
| G Models . . . . .      |              |                         | 20 Amp.                |
| <b>AUXILIARY HEATER</b> |              |                         |                        |
|                         | <u>Volts</u> | <u>Amps.<br/>(Cold)</u> | <u>RPM<br/>(Cold)</u>  |
| Blower Motor . . . . .  | 13.5         | 9.6 Max.                | 2700 Min.              |

## SECTION 1B

# AIR CONDITIONING

**NOTICE:** When performing air conditioning diagnosis on vehicles equipped with a catalytic converter, it will be necessary to warm the engine to a normal operating temperature before attempting to idle the engine for periods greater than five (5) minutes. Once the choke is open and fast idle speed reduced to a normal idle, diagnosis and adjustments can be made.

### CONTENTS

|   |    |  |    |
|---|----|--|----|
| General Description .....                 | 1  | Rear Duct .....  | 40 |
| C60 System (C-K & G Models).....          | 1  | Blower Motor Resistor .....  | 40 |
| Overhead Systems (C-K & G Models) .....   | 3  | Blower Motor Assembly .....  | 41 |
| System Control .....                      | 4  | Expansion Valve .....  | 41 |
| Motor Home Chassis System .....           | 7  | Evaporator Core.....   | 41 |
| Diagnosis .....                           | 9  | Blower Motor Switch.....   | 43 |
| Leak Testing The Refrigerant System ..... | 11 | Fuse .....   | 43 |
| Pressure Cycling System Diagnosis .....   | 11 | C60 System--G Models .....   | 43 |
| Compressor Diagnosis.....                 | 15 | Condenser.....   | 43 |
| Insufficient Cooling .....                | 15 | A/C Air Distributor Duct .....   | 43 |
| Electrical System Diagnosis .....         | 15 | A/C Center and Right Dash Outlets,<br>Heater, Air Distributor and Extension Ducts .... | 43 |
| Evacuating and Charging Procedures.....   | 27 | Heater Core Case and Core .....  | 44 |
| On Vehicle Service .....                  | 27 | Blower Motor .....   | 45 |
| Air Conditioning System Capacity .....    | 27 | Evaporator Core.....   | 45 |
| Checking Oil .....                        | 27 | Temperature Door Cable.....  | 45 |
| Thermostatic Switch.....                  | 32 | Control .....  | 45 |
| Expansion Valve .....                     | 33 | Blower Switch .....  | 46 |
| Engine Idle Compensator .....             | 32 | Blower Motor Relay .....   | 46 |
| Compressor .....                          | 33 | Resistors .....  | 46 |
| C60 System--C-K Models .....              | 33 | Blower Motor Relay .....   | 46 |
| Condenser.....                            | 35 | Vacuum Tank .....  | 51 |
| Accumulator-All .....                     | 35 | Circuit Breaker .....  | 51 |
| Blower Assembly .....                     | 35 | Overhead System--G Models .....  | 51 |
| Evaporator Core.....                      | 35 | Dash Mounted System--Motor Home Units .....  | 51 |
| Expansion Tube-All.....                   | 35 | Condenser.....   | 51 |
| Selector Duct and Heater Core.....        | 36 | Receiver-Dehydrator .....  | 51 |
| Kick Panel Air Valve.....                 | 36 | Sight Glass .....  | 52 |
| Plenum Air Valve .....                    | 36 | Blower-Evaporator Assembly.....  | 52 |
| Control Assembly .....                    | 36 | Blower Assembly .....  | 53 |
| Temperature Door Cable Adjustment .....   | 36 | Expansion Valve, Evaporator Case or Core .....   | 53 |
| Master Switch and/or Blower Switch.....   | 36 | Thermostatic and/or Blower Switches.....   | 53 |
| Vacuum Tank .....                         | 37 | Resistor .....   | 53 |
| Blower Resistor Unit .....                | 37 | Fuse .....   | 54 |
| Blower Motor Relay .....                  | 40 | Specifications .....   | 54 |
| Fuse .....                                | 40 | Special Tools .....  | 55 |
| Overhead System--C-K Models .....         | 40 |  |    |

## GENERAL DESCRIPTION

### C60 A/C SYSTEM

Both the heating and cooling functions are performed by this system. Air entering the vehicle must pass through the cooling unit (evaporator) and through (or around) the heating unit, in that order, and the system is referred to as a "reheat" system.

The evaporator provides maximum cooling of the air passing through the core when the air conditioning system is calling for cooling.

On C-K and G Series, compressor operation is controlled by a pressure sensing switch, located near the top of the accumulator. The switch responds to pressure changes to turn the compressor ON or OFF, as required.

System operation is as follows:

Air, either outside air or recirculated air, enters the system and is forced through the system by the blower. As

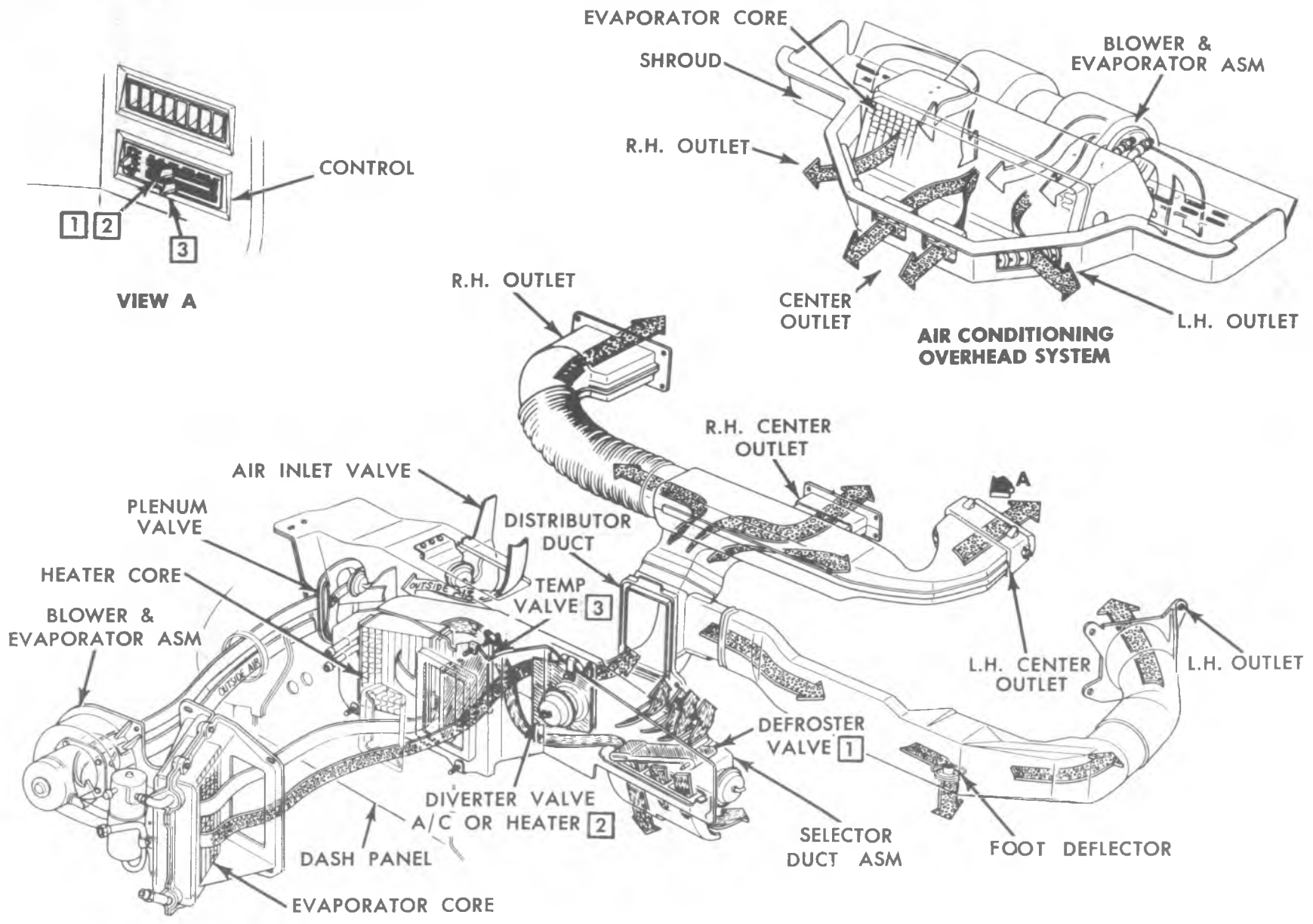

(CK) MODELS

Fig. 1B-1—Airflow Chart - C-K Models

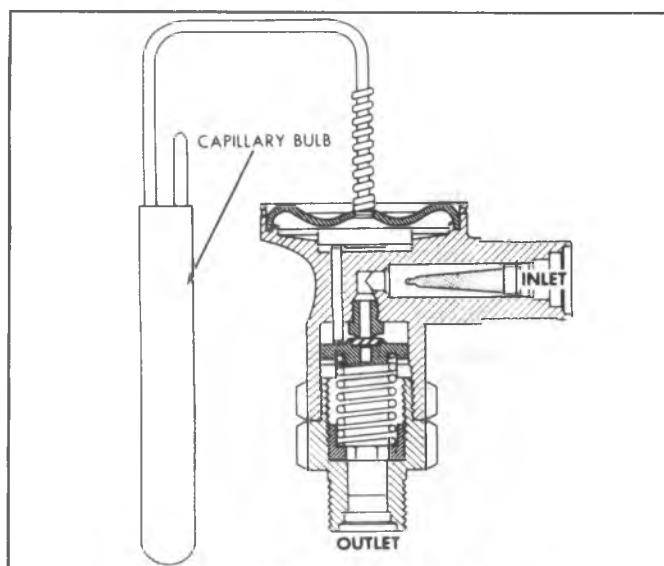

Fig. 1B-2--Expansion Valve

the air passes through the evaporator core, it receives maximum cooling if the air conditioning controls are calling for cooling. After leaving the evaporator, the air enters the heater and air conditioner selector duct assembly where, by means of diverter doors, it is caused to pass through or to bypass the heater core in the proportions necessary to provide the desired outlet temperature. Then conditioned air enters the vehicle through either the floor distributor duct or the dash outlets. During cooling operations, the air is cooled by the evaporator to below comfort level, it is then warmed by the heater to the desired temperature. During "heating only" operations, the evaporator will not be in operation and ambient air will be warmed to the desired level in the same manner.

## AIR DISTRIBUTION OUTLETS

### C-K Series

The dash outlets are rectangular in design. The outlets can be rotated horizontally or vertically to direct air as desired. Under the left distributor duct is located a floor cooler which can be rotated to provide cooling air or shut off completely.

### G-Van

The dash outlets are rectangular in design and can be rotated horizontally or vertically to direct air as desired. Foot coolers are provided on both driver and passenger side.

In the heater-defrost modes, the air conditioning outside air door is closed. The heater air door is open and outside air is allowed to pass through the heater core (receiving maximum heating) and is then directed into the passenger compartment through the heater and/or defroster outlets.

## OVERHEAD SYSTEMS (C-K & G SERIES)

These systems (C69 on C-K & G Series) operate in conjunction with the C60 System--they do not operate independently. However, control of rear blower motor speed is possible even when the front system is OFF, thus, rear air circulation without the refrigerant function may be had by operating the rear blower control switch.

These units are self contained, operating on inside (recirculated) air only. Air is drawn into the unit, passed through the evaporator core and then directed into the passenger compartment through the air distributor duct.

System control is through the front system. The only control on the overhead system is a three speed blower switch.

## MOTOR HOME CHASSIS SYSTEM

This system performs the cooling functions only. When heating (above ambient temperatures) is desired, the vehicle heater must be used. When air conditioning is desired, the heater should be completely shut OFF.

This self-contained unit is bracket mounted to the dash by the body manufacturer. It operates on inside (recirculated) air only. Air is drawn into the unit, passed through the evaporator core (receiving maximum cooling) and then directed into the vehicle through adjustable outlets.

A thermostatic switch, located on the face plate is used to control compressor operation by sensing air temperature as it leaves the evaporator core.

## System Components

### Receiver-Dehydrator (Motor Home Chassis Models)

The receiver-dehydrator, serving as a reservoir for storage of high pressure liquid produced in the condenser, incorporates a screen sack filled with the dehydrating agent.

The receiver-dehydrator, used primarily as a liquid storage tank, also functions to trap minute quantities of moisture and foreign material which may have remained in the system after installation or service operations. A refrigerant sight glass is built into the receiver-dehydrator to be used as a quick check of the state and condition of charge of the entire system. The receiver-dehydrator is mounted near the condenser.

### Sight Glass (Motor Home Chassis Models Only)

While having no real function to perform in the system, the sight glass is a valuable aid in determining whether or not the refrigerant charge is sufficient and for eliminating some guess work in diagnosing difficulties. The sight glass, is built into the receiver-dehydrator outlet connection and is designed and located so that a shortage of refrigerant at this point will be indicated by the appearance of bubbles beneath the glass. The dust cap provided should be kept in place when the sight glass is not in use.

### Thermostatic Expansion Valve (Fig. 1B-2)

C-K and G overhead, and motor home chassis systems use a thermostatic expansion valve in place of a float system.

The valve consists primarily of the power element, body, actuating pins, seat and orifice. At the high pressure liquid inlet, is a fine mesh screen which prevents dirt, filings or other foreign matter from entering the valve orifice.

When the valve is connected in the system, high pressure liquid refrigerant enters the valve through the screen from the receiver-dehydrator or condenser and passes on to the seat and orifice. Upon passing through the orifice the high pressure liquid becomes low pressure liquid. The low pressure liquid leaves the valve and flows into the

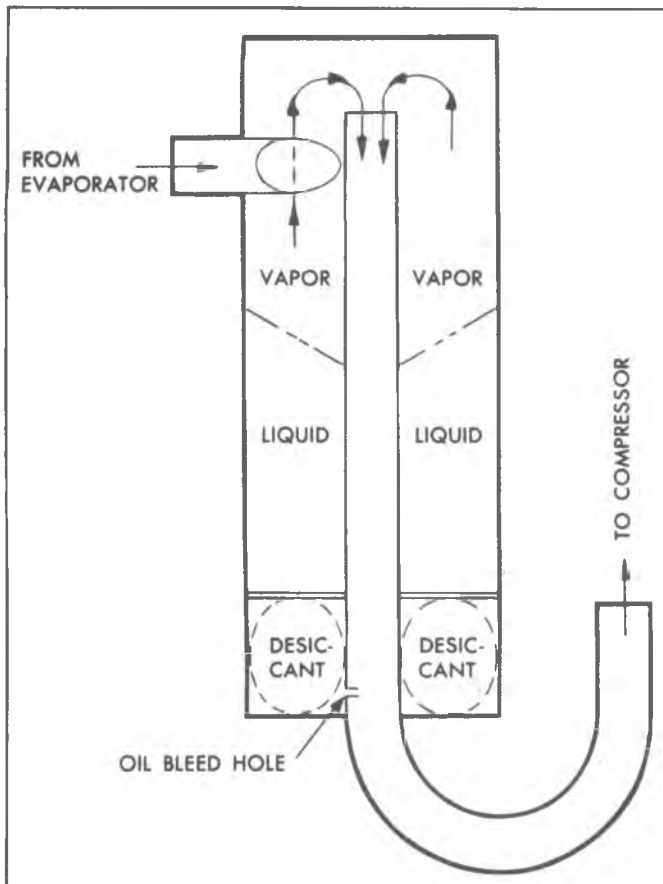

Fig. 1B-3--Accumulator-C-K, &amp; G Series With C60

evaporator core where it absorbs heat from the evaporator core and changes to a low pressure vapor, and leaves the evaporator core as such. The power element bulb is clamped to the low pressure vapor line just beyond the outlet of the evaporator (Fig. 1B-2).

### Accumulator--C-K, & G Series (Fig. 1B-3)

The accumulator is located at the evaporator outlet. Its most important function is not to "accumulate" although this too is important. Its primary function is to separate liquid retained from vapor, retain the liquid and release the vapor to the compressor.

Thus, in an ideal accumulator with no oil bleed hole, and in a correctly designed system, no liquid can get to the compressor.

In an actual accumulator, there is some entrained liquid in the vapor stream to the compressor.

Flow out of the accumulator to the compressor consists mostly of vapor with the addition of entrained liquid, and liquid flow through the oil bleed hole.

A bag of desiccant (dehydrating agent) is located in the accumulator as a moisture collecting device.

There is no sight glass in the accumulator-clutch cycle system.

### Expansion Tube--C-K, & G Series

Expansion tube flow rate depends on pressure difference and on subcooling; however, the flow rate is more sensitive to subcooling.

The expansion tube is located in the evaporator inlet line (Fig. 1B-4).

### Thermostatic Switch - Motor Home Chassis Units Only

System temperature is controlled by running the compressor intermittently, automatically turning it on and off as necessary to maintain proper temperatures. The compressor is started and stopped through the use of an electro-magnetic clutch and a thermostat affected by variations in temperature.

The thermostatic switch incorporates a metallic tube which contains a highly expansive gas. This tube is located in the air stream as it leaves the evaporator. The tube leads to a bellows operated switch. As air temperature rises, the gas inside the tube expands, travels through the tube to the bellows and closes the electrical switch which engages the compressor clutch.

As soon as the compressor starts running, the temperature begins to go down. As the air being cooled gets colder, the gas in the thermostatic tube begins to reduce the pressure on the switch bellows. This allows the switch contact to open and the compressor clutch disengages.

### Pressure Cycling Switch - Low Refrigerant Charge

#### Protection System - C-K&G Series

Low refrigerant charge protection is afforded by the pressure cycling switch as a secondary function. When refrigerant pressure drops below a certain predetermined level, the switch opens the compressor clutch circuit, shutting the system OFF.

## SYSTEM CONTROLS

### C60 SYSTEM (C-K & G SERIES) - FIG. 1B-5

#### System Operation - C-K Truck

System operation is shown in Fig. 1B-6.

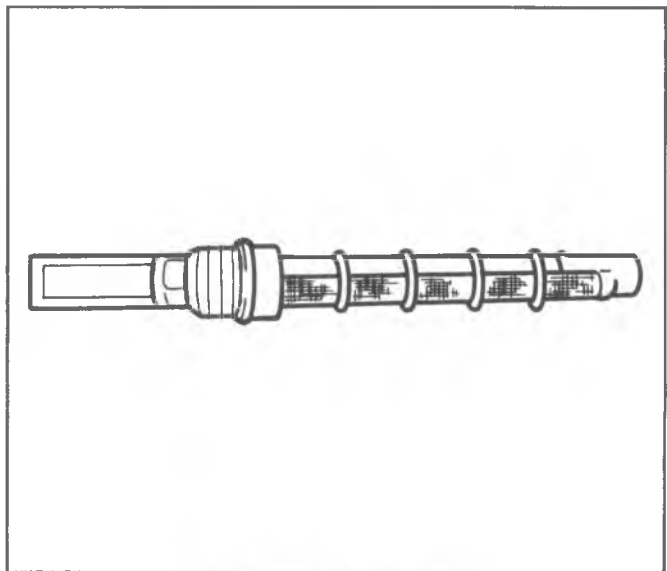
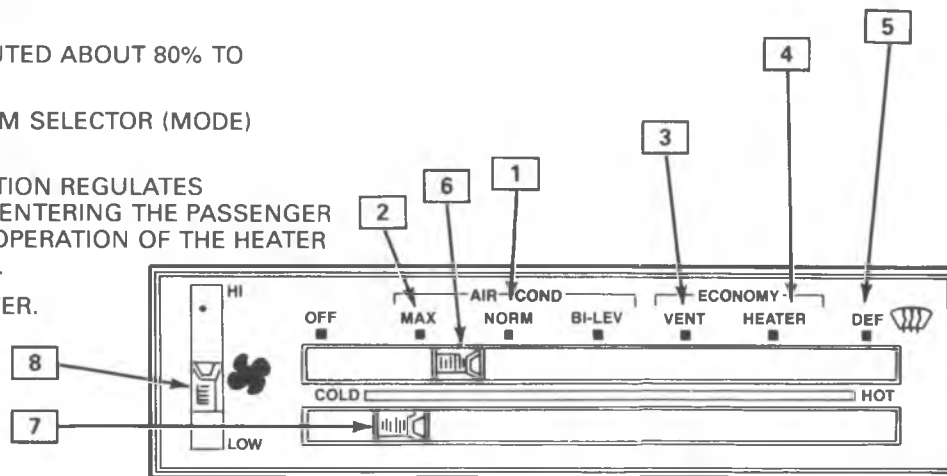

Fig. 1B-4--Expansion Tube



- 1 CONDITIONED AIR IS DIRECTED THROUGH W/SHLD. I.P. & FLOOR DISTRIBUTOR OUTLETS.
- 2 IN THIS MODE LEVER POSITION, MAXIMUM COOLING IS OFFERED WITH THE CONDITIONED AIR DISTRIBUTED THROUGH I.P. OUTLETS AT ANY BLOWER SPEED.
- 3 A NON-COMPRESSOR OPERATING POSITION, WITH OUTSIDE AIR DELIVERED THROUGH I.P. OUTLETS.
- 4 A NON-COMPRESSOR OPERATING POSITION, WITH OUTSIDE AIR DISTRIBUTED ABOUT 80% TO FLOOR & 20% TO W/SHLD.
- 5 CONDITIONED AIR DISTRIBUTED ABOUT 80% TO W/SHLD. & 20% TO FLOOR.
- 6 VACUUM OPERATED SYSTEM SELECTOR (MODE) LEVER.
- 7 TEMPERATURE LEVER POSITION REGULATES TEMPERATURE OF THE AIR ENTERING THE PASSENGER COMPARTMENT BY CABLE OPERATION OF THE HEATER CORE TEMPERATURE DOOR.
- 8 4-SPEED FAN CONTROL LEVER.



104214

SYSTEM OPERATION - CK TRUCK

| SELECTOR LEVER POSITION | COMPRESSOR | BLOWER SPEEDS AVAIL | AIR SOURCE | AIR ENTERS VEHICLE     | HEATER A/C DOOR-OPEN TO: | HEATER DEFROSTER DOOR-OPEN TO: |
|-------------------------|------------|---------------------|------------|------------------------|--------------------------|--------------------------------|
| OFF                     | OFF        | LOW                 | OUTSIDE    | FLOOR OUTLETS          | HEATER                   | HEATER                         |
| MAX A/C                 | ON         | HI                  | INSIDE%    | DASH OUTLETS           | A/C                      | HEATER                         |
| NORM A/C                | ON         | ALL                 | OUTSIDE    | DASH OUTLETS           | A/C                      | HEATER                         |
| BI-LEVEL                | ON         | ALL                 | OUTSIDE    | FLOOR AND DASH OUTLETS | A/C & HEATER             | HEATER                         |
| VENT                    | OFF        | ALL                 | OUTSIDE    | DASH OUTLETS           | A/C                      | HEATER                         |
| HTR                     | OFF        | ALL                 | OUTSIDE    | FLOOR OUTLETS          | HEATER                   | HEATER                         |
| DEF                     | ON         | ALL                 | OUTSIDE    | DEFROST OUTLETS        | HEATER                   | DEFROST                        |

NOTE % 100% Inside air is not available, some bleed through of outside air is allowed.

Fig. 1B-6--System Operation - C-K Truck

### Vacuum Schematic - C-K Truck

The C-K Truck air conditioning vacuum schematic is shown in Fig. 1B-7.

### System Operation - G Models

System operation is shown in Fig. 1B-8.

### Vacuum Schematic - G Models

G Model vacuum schematic is shown in Fig. 1B-9.

### OVERHEAD SYSTEM (C-K & G SERIES)

This system operates in conjunction with the C60 system. Since refrigerant flow is controlled by the front system, the only control provided for on the overhead system is a three-speed fan switch (LOW, MED, HI). The fan

switch is mounted in the instrument panel, to the right of the steering column (Fig. 1B-10).

In the OFF position, the blower is inoperative; however, refrigerant is circulating in the system if the C60 System is ON. In any of the three blower positions (LOW, MED, HI), the blower will be operative regardless if the Four-Season system is ON.

To obtain maximum cooling, the Four-Season System should be on A/C, temperature lever on COLD, blower switch on HI and the overhead unit blower switch should be on HI.

### OVERHEAD SYSTEM (G MODELS)

This system operates in conjunction with the C60 system. Since refrigerant is controlled by the C60 system, the only control provided on the rear overhead system is a

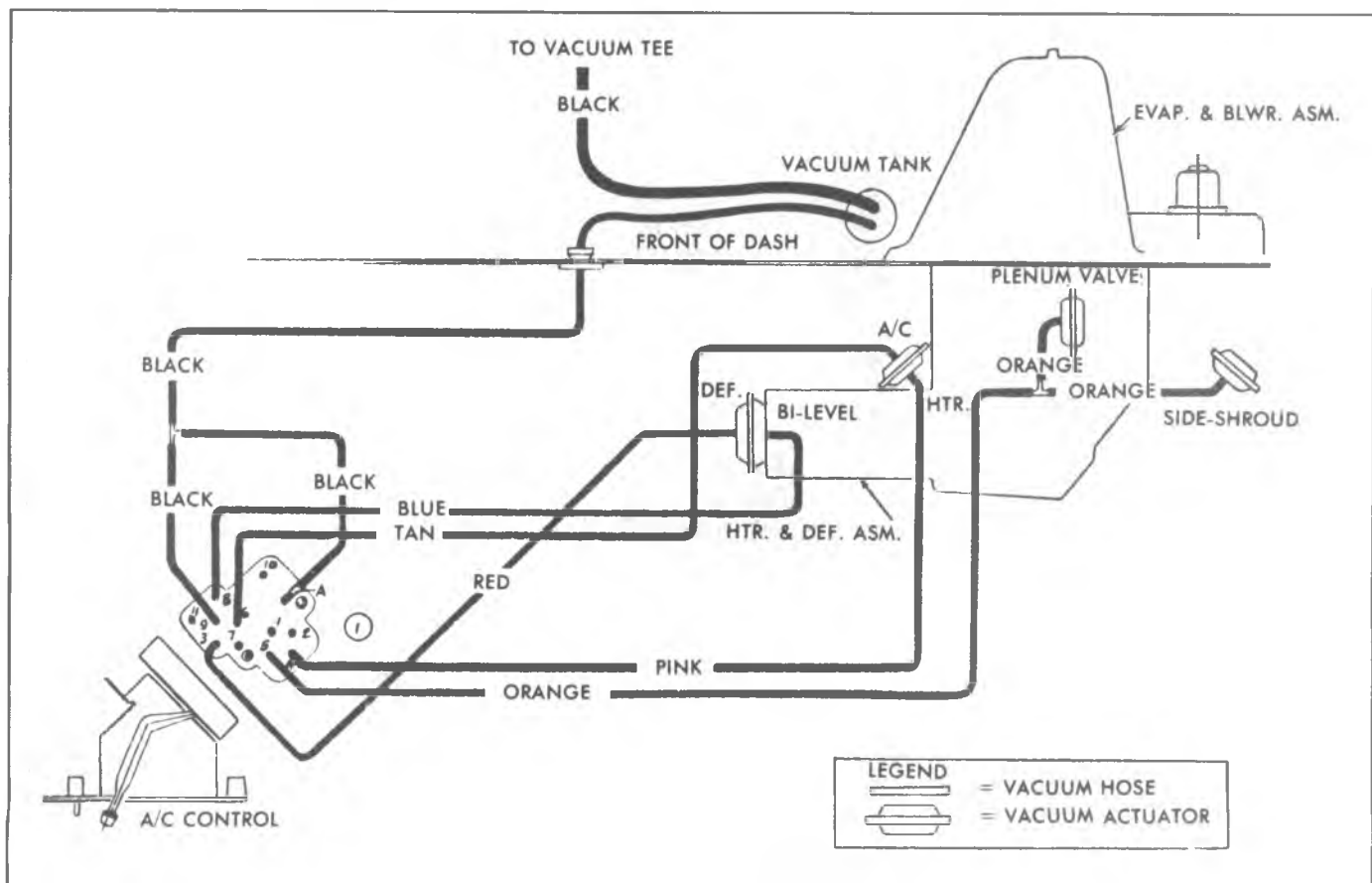

Fig. 1B-7--Air Conditioning Vacuum Schematic - C-K Truck

| COMPRESSOR |     | BLOWER SPEEDS AVAIL | AIR SOURCE | AIR ENTERS VEHICLE                  | HEATER DEFROSTER DOOR | HEATER A/C DOOR |
|------------|-----|---------------------|------------|-------------------------------------|-----------------------|-----------------|
| OFF        | OFF | NONE                | OUTSIDE    | FLOOR OUTLETS                       | OPEN TO               | OPEN TO         |
|            |     |                     |            |                                     | HEATER                | HEATER-DEF      |
| MAX        | ON  | ALL                 | INSIDE %   | DASH OUTLETS                        | HEATER                | A/C             |
| NORM       | ON  | ALL                 | OUTSIDE    | DASH OUTLETS                        | HEATER                | A/C             |
| BI LEV     | ON  | ALL                 | OUTSIDE    | DASH OUTLETS<br>FLOOR OUTLETS       | HEATER                | A/C &<br>HEATER |
| VENT       | OFF | ALL                 | OUTSIDE    | DASH OUTLETS                        | HEATER                | A/C             |
| HEATER     | OFF | ALL                 | OUTSIDE    | BLEED TO DEFROST<br>& FLOOR OUTLETS | HEATER                | HEATER          |
| DEFR       | ON* | ALL                 | OUTSIDE    | DEFROST OUTLETS                     | DEFROST               | HEATER          |

\*PROVIDED COMPRESSOR PRESSURE SWITCH CLOSED

Fig. 1B-8--System Operation - G Models

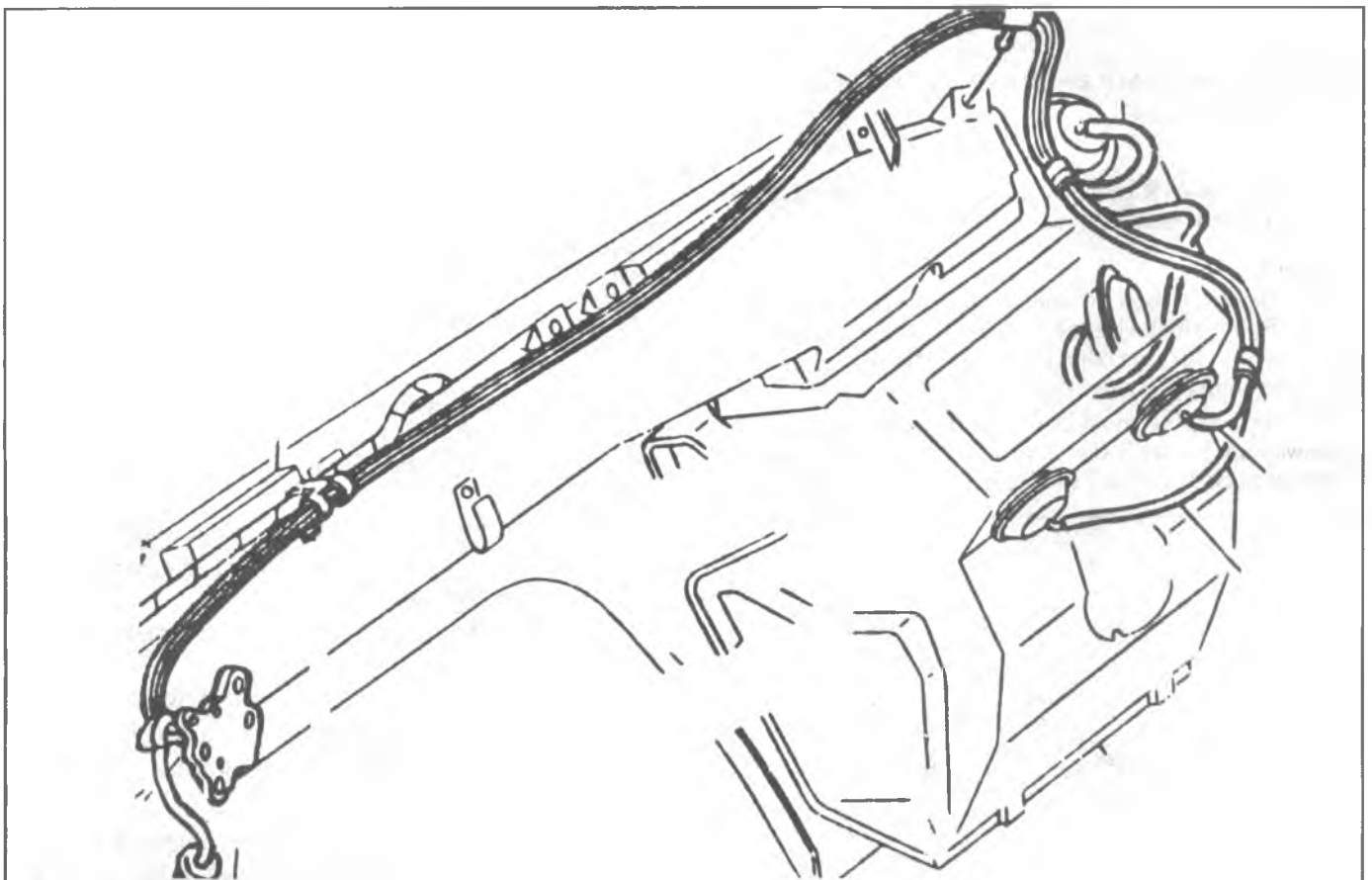

Fig. 1B-9--Vacuum Schematic - G Models

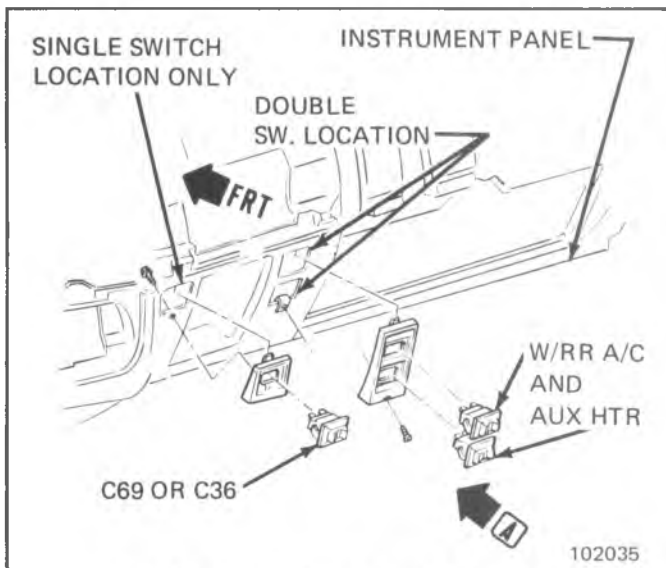

Fig. 1B-10--Overhead Unit Control (C-K Series)

three speed blower switch (Fig. 1B-11).

In the OFF position, the blower is inoperative; however, refrigerant is circulating in the system if the front system is ON. To operate the rear overhead system, simply select the desired blower speed (LOW, MED, HI).

When air circulation only is desired, the rear A/C blower motor may be operated independent of the front A/C blower motor and without the cooling function.

### DASH MOUNTED UNIT (MOTOR HOME CHASSIS UNITS)

This system is self contained and is mounted below the dash by the body manufacturer. System controls consist of an AIR knob and TEMP knob located in the center of the unit face plate (Fig. 1B-12).

#### Air Knob

Turning the AIR knob clockwise operates a three speed (LOW-MED-HI) blower motor.

#### Temp Knob

This knob is used to control the degree of cooling desired. Fully clockwise at CITY provides maximum cooling, while turning the knob to HIWAY provided adequate cooling for highway operation.

Reduced cooling could be encountered when operating at highway speeds with the controls at the CITY setting. The heater must be fully off to obtain maximum cooling.

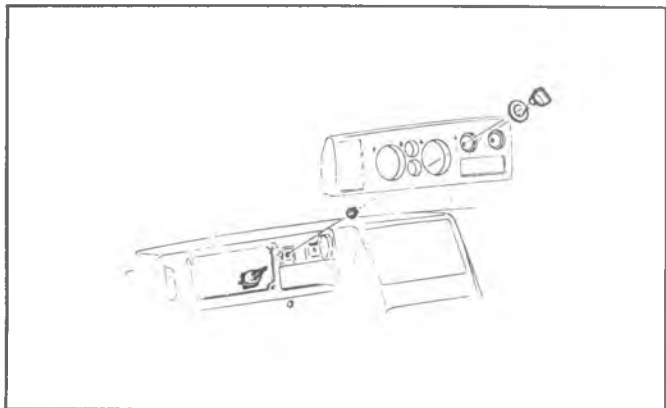

Fig. 1B-11--Overhead Unit Control (G Models)

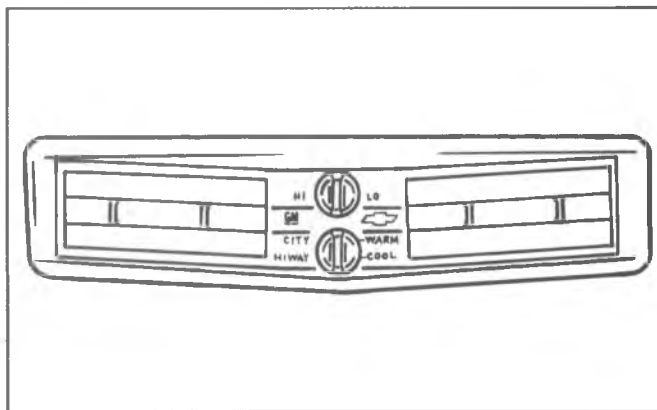

Fig. 1B-12--Motor Home Unit Control

### CCOT SYSTEM COMPONENTS

CCOT Refrigerant System components and refrigerant flow are shown in Fig. 1B-13. Chart 1B-1 shows pressure temperature relationships of R-12.

### Refrigerant and Oil Capacities

Refrigerant and oil charge is shown in Chart 1B-2.

### HANDLING REFRIGERANT-12

Air conditioning systems contain Refrigerant-12. This is a chemical mixture which requires special handling procedures to avoid personal injury.

Always wear goggles and wrap a clean cloth around fittings, valves and connections when performing work that involved opening the refrigerant system. Always work in a well ventilated area and do not weld or steam clean on or near any car installed air conditioning lines or components.

If Refrigerant-12 should come in contact with any part of the body, flush the exposed area with cold water and immediately seek medical help.

All Refrigerant-12 drums are shipped with a heavy metal screw cap. The purpose of the cap is to protect the valve and safety plug from damage. It is good practice to replace the cap after each use of the drum for this same reason.

If it is necessary to transport or carry any container of Refrigerant-12 in a vehicle, do not carry it in the passenger compartment.

If the occasion arises to fill a small Refrigerant-12 drum from a large one, never fill the drum completely. Space should always be allowed above the liquid for expansion.

1. Do not leave drum of Refrigerant-12 uncapped.
2. Do not carry any container of Refrigerant-12 in passenger compartment of car.
3. Do not subject any container of Refrigerant-12 to high temperature.
4. Do not weld or steam clean on or near system.
5. Do not fill drum of Refrigerant-12 completely.
6. Do not discharge vapor into area where flame is exposed.
7. Avoid breathing smoke and fumes produced by the burning of the Refrigerant-12. Such fumes may be hazardous.
8. One of the most important cautions concerns the

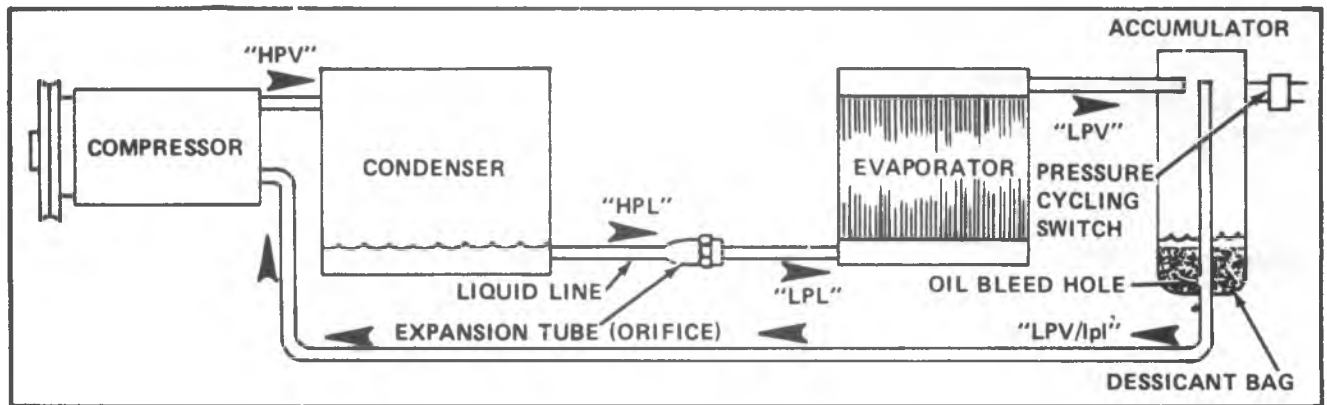

**PRESSURE CYCLING SYSTEM**

- "HPV" - HIGH PRESSURE VAPOR LEAVING COMPRESSOR.
- "HPL" - VAPOR IS COOLED DOWN BY CONDENSER AIR FLOW AND LEAVES AS HIGH PRESSURE LIQUID.
- "LPL" - ORIFICE METERS THE LIQUID R-12, INTO EVAPORATOR, REDUCING ITS PRESSURE, AND WARM BLOWER AIR ACROSS EVAPORATOR CORE CAUSES BOILING OFF OF LIQUID INTO VAPOR.
- "LPV" - LEAVES EVAPORATOR AS LOW PRESSURE VAPOR AND RETURNS WITH THE SMALL AMOUNT OF . . .
- "lpl" - . . . LOW PRESSURE LIQUID THAT DIDN'T BOIL OFF COMPLETELY BACK TO THE COMPRESSOR TO BE COMPRESSED AGAIN.

Fig. 1B-13--CCOT System Components

eyes. Any liquid Refrigerant-12 which may accidentally escape is approximately 21°F (-6°C) below zero. If liquid Refrigerant-12 should touch the eyes, serious damage could result. Always wear goggles to protect the eyes when opening refrigerant connections. If Refrigerant-12 liquid should strike the eye:

- a. Call a doctor or eye specialist immediately and obtain treatment as soon as possible.
- b. **DO NOT RUB THE EYE.** Splash the affected area with quantities of cold water to gradually get the temperature above the freezing point.

- c. The use of an antiseptic oil is helpful in providing a protective film over the eyeball to reduce the possibility of infection. Should liquid Refrigerant-12 come into contact with the skin, the injury should be treated the same as skin which has been frostbitten or frozen.

All Refrigerant-12 drums are shipped with a heavy metal screw cap. The purpose of the cap is to protect the valve

**REFRIGERANT — 12  
PRESSURE — TEMPERATURE  
RELATIONSHIP**

The table below indicates the pressure of Refrigerant — 12 at various temperatures. For instance, a drum of Refrigerant at a temperature of 80°F (26.6°C) will have a pressure of 84.1 PSI (579.9 kPa). If it is heated to 125°F (51.6°C), the pressure will increase to 167.5 PSI (1154.9 kPa). It also can be used conversely to determine the temperature at which Refrigerant — 12 boils under various pressures. For example, at a pressure of 30.1 PSI (207.5 kPa), Refrigerant — 12 boils at 32°F (0°C).

| (°F)(°C) |        | (PSIG)(kPa) |              | (°F)(°C) |       | (PSIG)(kPa) |        |
|----------|--------|-------------|--------------|----------|-------|-------------|--------|
| -21.7    | -29.8C | 0           | (ATMOSPHERIC | 55       | 12.7C | 52.0        | 358.5  |
|          |        |             | 0)(kPa)      | 60       | 15.5C | 57.7        | 397.8  |
|          |        |             | PRESSURE)    | 65       | 18.3C | 63.7        | 439.2  |
| -20      | -28.8C | 2.4         | 16.5         | 70       | 21.1C | 70.1        | 482.7  |
| -10      | -23.3C | 4.5         | 31.0         | 75       | 23.8C | 76.9        | 530.2  |
| -5       | -20.5C | 6.8         | 46.9         | 80       | 26.6C | 84.1        | 579.9  |
| 0        | -17.7C | 9.2         | 63.4         | 85       | 29.4C | 91.7        | 632.3  |
| 5        | -15.0C | 11.8        | 81.4         | 90       | 32.2C | 99.6        | 686.7  |
| 10       | -12.2C | 14.7        | 101.4        | 95       | 35.0C | 108.1       | 745.3  |
| 15       | -9.4C  | 17.7        | 122.0        | 100      | 37.7C | 116.9       | 806.0  |
| 20       | -6.6C  | 21.1        | 145.5        | 105      | 40.5C | 126.2       | 870.2  |
| 25       | -3.8C  | 24.6        | 169.6        | 110      | 43.3C | 136.0       | 937.7  |
| 30       | -1.1C  | 28.5        | 196.5        | 115      | 46.1C | 146.5       | 1010.1 |
| 32       | 0C     | 30.1        | 207.5        | 120      | 48.8C | 157.1       | 1083.2 |
| 35       | 1.6C   | 32.6        | 224.8        | 125      | 51.6C | 167.5       | 1154.9 |
| 40       | 4.4C   | 37.0        | 255.1        | 130      | 54.4C | 179.0       | 1234.2 |
| 45       | 7.2C   | 41.7        | 287.5        | 140      | 60.0C | 204.5       | 1410.0 |
| 50       | 10.0C  | 46.7        | 322.0        |          |       |             |        |

| Refrigerant Charge |                 |                 |
|--------------------|-----------------|-----------------|
|                    | Overhead System | C60 System      |
| C-K Models         | 5 lbs.-4 oz.    | 3 Lbs. - 12 oz. |
| G Models           | 5 lbs.          | 3 lbs.          |

and safety plug from damage. It is good practice to replace the cap after each use of the drum for the same reason.

If it is necessary to transport or carry any container of Refrigerant-12 in a car, keep it in the luggage compartment. If the drum is exposed to the radiant heat of the sun, the resultant increase in pressure may cause the safety plug to release or the drum to burst.

Welding or steam cleaning near any of the refrigerant lines or components of the air conditioning system could build up dangerous and damaging pressures in the system.

If the occasion arises to fill a small Refrigerant-12 drum from a large one, never fill the drum completely. Space should always be allowed above the liquid for expansion. If the Refrigerant-12 drum were completely full and the temperature was increased, tremendous hydraulic force could be developed.

## HANDLING OF REFRIGERANT LINES AND FITTINGS

Tighten all tubing connections as shown in torque chart 1B-7. Insufficient or excessive torque when tightening can result in loose joints or deformed joint parts. Either condition can result in refrigerant leakage.

- All metal tubing lines should be free of dents or kinks to prevent loss of system capacity due to line restriction.
- The flexible hose lines should never be bent to a radius of less than 4 times the diameter of the hose.
- The flexible hose lines should never be allowed to come within a distance of 63.5mm (2-1/2 in.) of the exhaust manifold.
- Flexible hose lines should be inspected regularly for leaks or brittleness and replaced with new lines if deterioration or leaking is found.
- When disconnecting any fitting in the refrigeration system, the system must first be discharged of all refrigerant-12. However, proceed very cautiously regardless of gage readings. Open very slowly, keeping face and hands away so that no injury can occur if there happens to be liquid Refrigerant-12 in the line. If

pressure is noticed when fitting is loosened, allow it to bleed off as described under DISCHARGING, ADDING OIL, EVACUATING AND CHARGING PROCEDURES FOR C.C.O.T. A/C SYSTEMS.

- In the event any line is opened to atmosphere, it should be immediately capped or taped to prevent entrance of moisture and dirt, which can cause internal compressor wear or plugged lines, condenser and evaporator core, expansion tubes (orifice) or compressor inlet screens.
- The use of the proper wrenches when making connections on "O" ring fittings is important. The use of improper wrenches may damage the connection. The opposing fitting should always be backed up with a wrench to prevent distortion of connecting lines or components. When connecting the flexible hose connections it is important that the swaged fitting and the flare nut, as well as the coupling to which it is attached, be held at the same time using three different wrenches to prevent turning the fitting and damaging the ground seat.
- "O" rings and seats must be in perfect condition. A burr or piece of dirt may cause a refrigerant leak. Always replace the "O" ring when a connection has been broken. When replacing the "O" ring, first dip it in clean 525 viscosity refrigeration oil.
- Where steel to aluminum connections are being made, use torque for aluminum tubing (Refer to Chart 1B-11).

## MAINTAINING CHEMICAL STABILITY IN THE REFRIGERATION SYSTEM

The efficient operation of the air conditioning refrigeration system is dependent upon the chemical stability of the refrigeration system.

When foreign materials, such as dirt, air or moisture contaminate the system, they will change the stability of Refrigerant-12. They will also affect pressure-temperature relationships, reduce efficient operation, possibly cause interior corrosion and abnormal wear of moving parts.

The following general practices should be observed to ensure chemical stability in the system:

1. Before disconnecting a refrigerant connection, wipe away any dirt or oil at and near the connection to reduce the possibility of dirt entering the system. Both sides of the connection should be capped, plugged or taped as soon as possible to prevent the entrance of dirt, foreign material and moisture.
2. Keep tools clean and dry. This includes the manifold Gage set and replacement parts.
3. When adding 525 viscosity refrigerant oil (Refer to ADDING OIL in the Discharging, Adding Oil, Evacuating and Charging Procedures for CCOT A/C Systems, the transfer device and container should be clean and dry to assure that refrigeration oil remains as moisture free as possible.
4. When it is necessary to "open" an A/C system, have everything needed ready and handy so that as little time as possible will be required to perform the operation. Do not leave the A/C system open any longer than is necessary.
5. Any time the A/C system has been "opened," it

should be properly Evacuated before recharging with Refrigerant-12 according to the DISCHARGING ADDING OIL, EVACUATING & CHARGING PROCEDURES FOR CCOT A/C SYSTEMS.

All service parts are dehydrated and sealed prior to shipping. They should remain sealed until just prior to

making connections. All parts should be at room temperature before uncapping (this prevents condensation of moisture from the air entering the system). If, for any reason, caps are removed, but the connections are not made, parts should be resealed as soon as possible.

## DIAGNOSIS

### TESTING THE REFRIGERANT SYSTEM

If a malfunction in the refrigerant system is suspected due to abnormal system pressures, check the following:

1. Check outer surfaces of radiator and condenser cores to be sure they are not plugged with dirt, leaves or other foreign material. Be sure to check between the condenser and radiator as well as the outer surfaces.
2. Restrictions or kinks in evaporator core or condenser core, hoses, tubes, etc.
3. Refrigerant leaks.
4. Check all air ducts for leaks or restrictions. Air restriction may indicate a plugged (or partially plugged) evaporator core.
5. Compressor clutch slippage.
6. Improper drive belt tension.
7. Plugged accumulator, expansion tube (orifice) or plugged suction inlet screen (A6 Compressor).
8. Excessive moisture in refrigerant system. Diagnose A/C system according to C.C.O.T. System Diagnostic Procedure (Charts 1B-4 and 1B-5).

### LEAK TESTING THE REFRIGERANT SYSTEM

#### Liquid Leak Detectors

There are a number of locations (fittings, valves, etc.) on the air conditioning system where a liquid leak detector solution may be used to pinpoint refrigerant leaks.

By applying test solution to the area in question with the swab that is attached to the bottle cap, bubbles will form within seconds if there is a leak.

For restricted access areas, such as sections of the evaporator and condenser, a Leak Detector such as J-6084 or equivalent is more practical for determining and locating leaks.

#### J-6084 Leak Detector

Tool J-6084 is a propane gas-burning torch which is used to locate a leak in any part of the system. Refrigerant gas drawn into the sampling tube attached to the torch will cause the torch flame to change color in proportion to the size of the leak. Propane gas fuel cylinders used with the torch are readily available commercially throughout the country.

**CAUTION: Do not use a lighted detector in any place where combustible or explosive gases, dusts or vapors may be present.**

#### Operating Detector

1. Determine if there is sufficient refrigerant in the system for leak testing.
2. Open control valve only until a low hiss of gas is heard, then light gas at opening in chimney.

3. Adjust flame until desired volume is obtained. This is most satisfactory when blue flame is approximately 3/8 in. above reactor plate. The reaction plate will quickly heat to a cherry red.

4. Explore for leaks by moving the end of the sampling hose around possible leak points in the system. Do not pinch or kink hose.

Since Refrigerant-12 is heavier than air, it is good practice to place open end of sampling tube immediately below point being tested, particularly in cases of small leaks.

**CAUTION: Do not breathe the fumes that are produced by the burning of Refrigerant-12 gas in the detector flame, since such fumes can be toxic in large concentrations.**

5. Watch for color changes. The color of the flame which passes through the reaction plate will change to green or yellow-green when sampling hose draws in very small leaks of Refrigerant-12. Large leaks will be indicated by a change in color to a brilliant blue or purple; when the sampling hose passes the leaks, the flame will clear to an almost colorless pale-blue again. Observations are best made in a semi-darkened area. If the flame remains yellow when unit is removed from leak, insufficient air is being drawn in or the reaction plate is dirty.

A refrigerant leak in the high pressure side of the system may be more easily detected if the system is operated for a few minutes, then shut off and checked immediately (before system pressures equalize). A leak on the low pressure side may be more easily detected after the engine has been shut off for several minutes (system pressures equalized); this applies particularly to the front seal.

### PRESSURE CYCLING CCOT SYSTEM

#### C60, C-K and G MODELS

Compressor clutch cycling on C-K&G Series C60 CCOT A/C Systems is accomplished through the use of a pressure sensing switch, (Refer to Fig. 1B-21 & 1B-22) located near the top of the accumulator. The switch performs two functions in the system. In addition to cycling the compressor on and off to control refrigerant flow, the switch shuts off the compressor clutch when pressure falls to a predetermined level, indicating low refrigerant charge in the system.

When diagnosis (Refer to Chart 1B-3 & 1B-4) indicates replacement of the switch is necessary, it should be noted that it will not normally be necessary to discharge the A/C system, as the pressure switch fitting on the accumulator is equipped with a schrader type valve.

When replacing the pressure cycling switch, a new oiled "O" ring must be installed and the switch must be torqued to 10 N·m (7.5 ft lb). Do not exceed this torque, as the threads in the accumulator may be stripped.

INSUFFICIENT COOLING — AC SYSTEMS WITH CYCLING CLUTCH—EXPANSION TUBE (PRESSURE CYCLING)

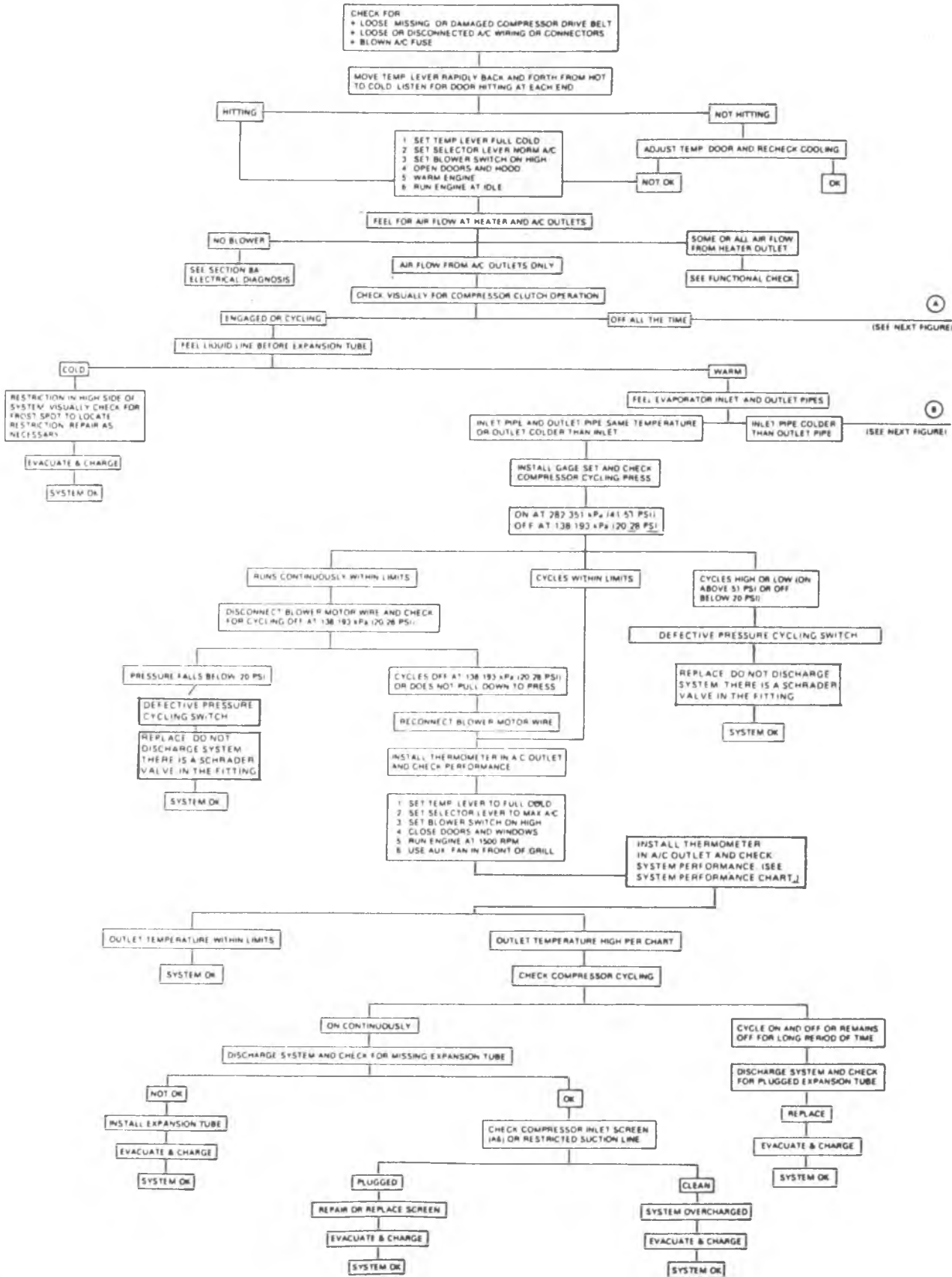



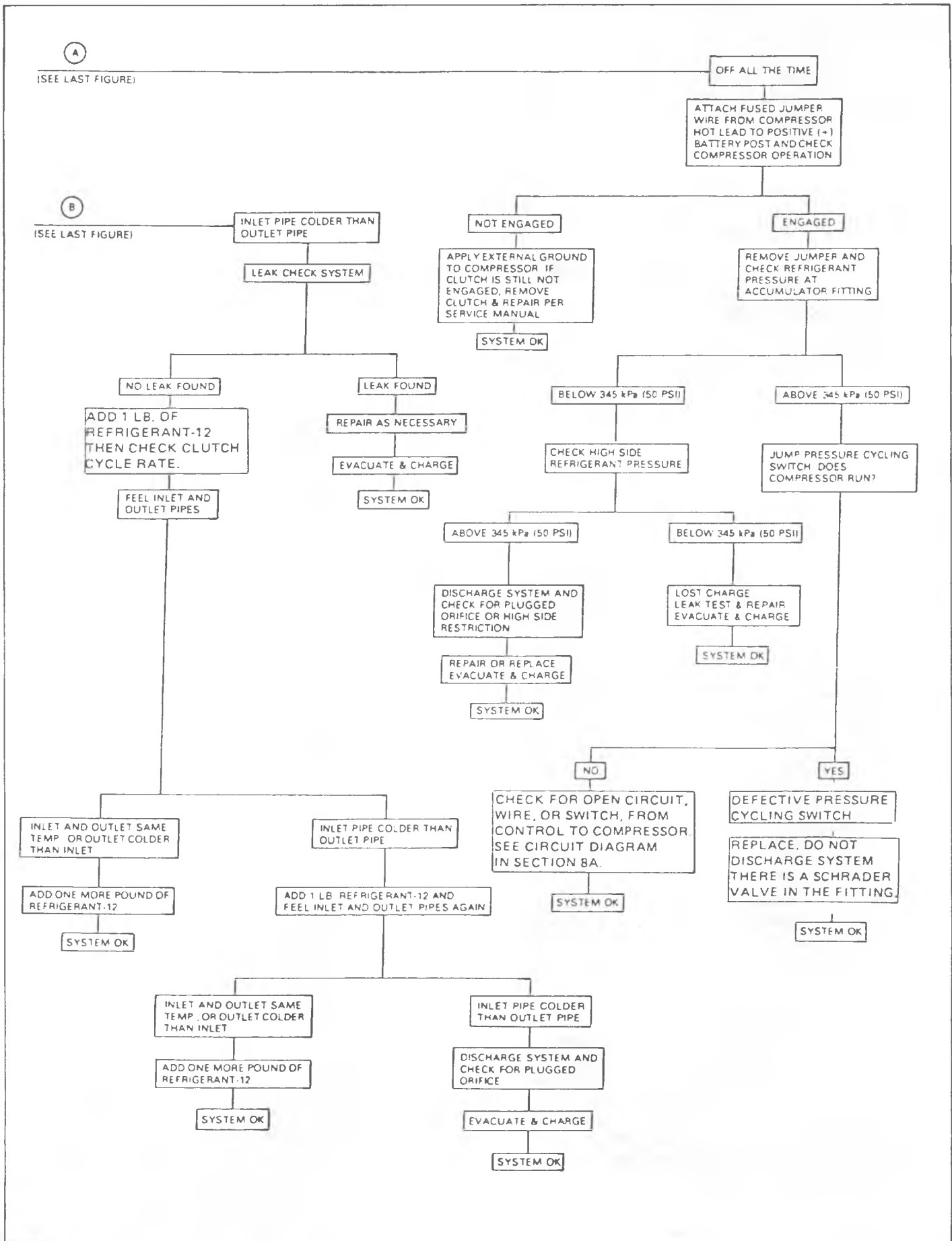

## ELECTRICAL/VACUUM TROUBLE DIAGNOSIS

When diagnosing problems in the electrical and vacuum systems of the air conditioning system, consult electrical wiring diagrams and vacuum diagrams.

Ports on rotary vacuum valves are illustrated in a manner to provide simplicity in following vacuum schematic lines but are numbered in consecutive order on the actual valve.

### Operational Test

To aid in determining whether or not the air conditioning electrical, air, vacuum and refrigeration systems are operating properly and efficiently, refer to Chart 1B-3.

## VACUUM SYSTEM DIAGNOSIS

### C-K and G, C60 SYSTEM

Start the engine and allow it to idle - move the selector lever to each position and refer to the vacuum diagrams and operational charts for proper airflow, air door functioning and vacuum circuits. If air flow is not out of the proper outlets at each selector lever position, then proceed as follows:

1. Check for good hose connections--at the vacuum actuators, control head valve, reservoir, tees, etc.

2. Check the vacuum source circuit as follows:

Install vacuum tee and gage (with restrictor) at the vacuum tank outlet (Refer to Vacuum Diagram). Idle the engine and read the vacuum (a normal vacuum is equivalent to manifold vacuum) at all selector lever positions.

- a. Vacuum Less Than Normal At All Positions -

Remove the tee and connect the vacuum gage line directly to the tank - read the vacuum. If still low, then the problem lies in the feed circuit, the feed circuit to the tank or in the tank itself. If vacuum is now normal, then the problem lies downstream.

- b. Vacuum Less Than Normal at Some Positions.

If vacuum was low at one or several of the selector lever positions, a leak is indicated in these circuits.

- c. Vacuum Normal at All Positions;

If vacuum was normal and even at all positions, then the malfunction is probably caused by improperly connected or plugged lines or a defective vacuum valve or valves.

3. Specific Vacuum Circuit Check

Place the selector lever in the malfunctioning position and check for vacuum at the pertinent vacuum actuators. If vacuum exists at the actuator but the door does not move, then the actuator is defective or the door is mechanically bound. If low or no vacuum exists at the actuator, then the next step is to determine whether the cause is the vacuum harness or the vacuum valve. Check the vacuum harness first.

4. Vacuum Harness Circuit Check

- a. Disconnect the vacuum harness at the control head.

1. Operation of the air conditioning blower at all four speeds and engagement of the compressor clutch would indicate that electrical circuits are functioning properly.
2. The same hand-felt temperature of the evaporator inlet pipe and the accumulator can surface of an operating system would indicate a properly charged R-12 system.
3. Operation of the A/C control selector (mode) lever to distribute air from designed outlets would indicate proper vacuum and diaphragm function.

- b. The black line (#1) should show engine vacuum - if not, trace back through connector to vacuum tank.

- c. To check any individual circuit place the selector lever at the involved circuit position and check for vacuum presence.

## VACUUM AND WIRING DIAGRAMS

Refer to Fig. 1B-14 thru 1B-22.

## A/C REFRIGERANT SYSTEM DIAGNOSIS

### INSUFFICIENT COOLING "QUICK-CHECK" PROCEDURE

The following CCOT "Hand-Feel" procedure can be used to quickly determine whether or not the A/C system has the proper charge of Refrigerant-12 (providing ambient temperature is above 21°C (70°F) This check can be made in a matter of minutes, simplifying system diagnosis by pinpointing the problem to the amount of Refrigerant-12 charge in the system or by eliminating this possibility from the over-all checkout.

1. Engine must be warm (CHOKE OPEN and OFF FAST IDLE SPEED CAM) and at normal idle speed.
2. Hood and body doors open.
3. Selector (mode) lever set at NORM.
4. Temperature lever at COLD.
5. Blower on HI.
6. "Hand-Feel" temperature of evaporator inlet pipe after orifice and accumulator can surface with compressor engaged.
  - a. BOTH SAME TEMPERATURE AND SOME DEGREE COOLER THAN AMBIENT--Proper condition: check for other problems (Refer to A/C System Diagnostic Procedure).
  - b. INLET PIPE COOLER than accumulator surface low refrigerant charge.
    - Add slight amounts 120 ml (1/4 lb.) of refrigerant UNTIL BOTH feel the same temperature. Allow stabilization time between additions.
    - Then add 420 ml (.88 lbs.) one can additional refrigerant. (The 420 ml/14 oz. disposable can of Refrigerant-12 is the equivalent to .88 lbs.)
  - c. INLET PIPE HAS FROST ACCUMULATION--Accumulator surface warmer; proceed as in Step b above.

## COMPRESSOR DIAGNOSIS

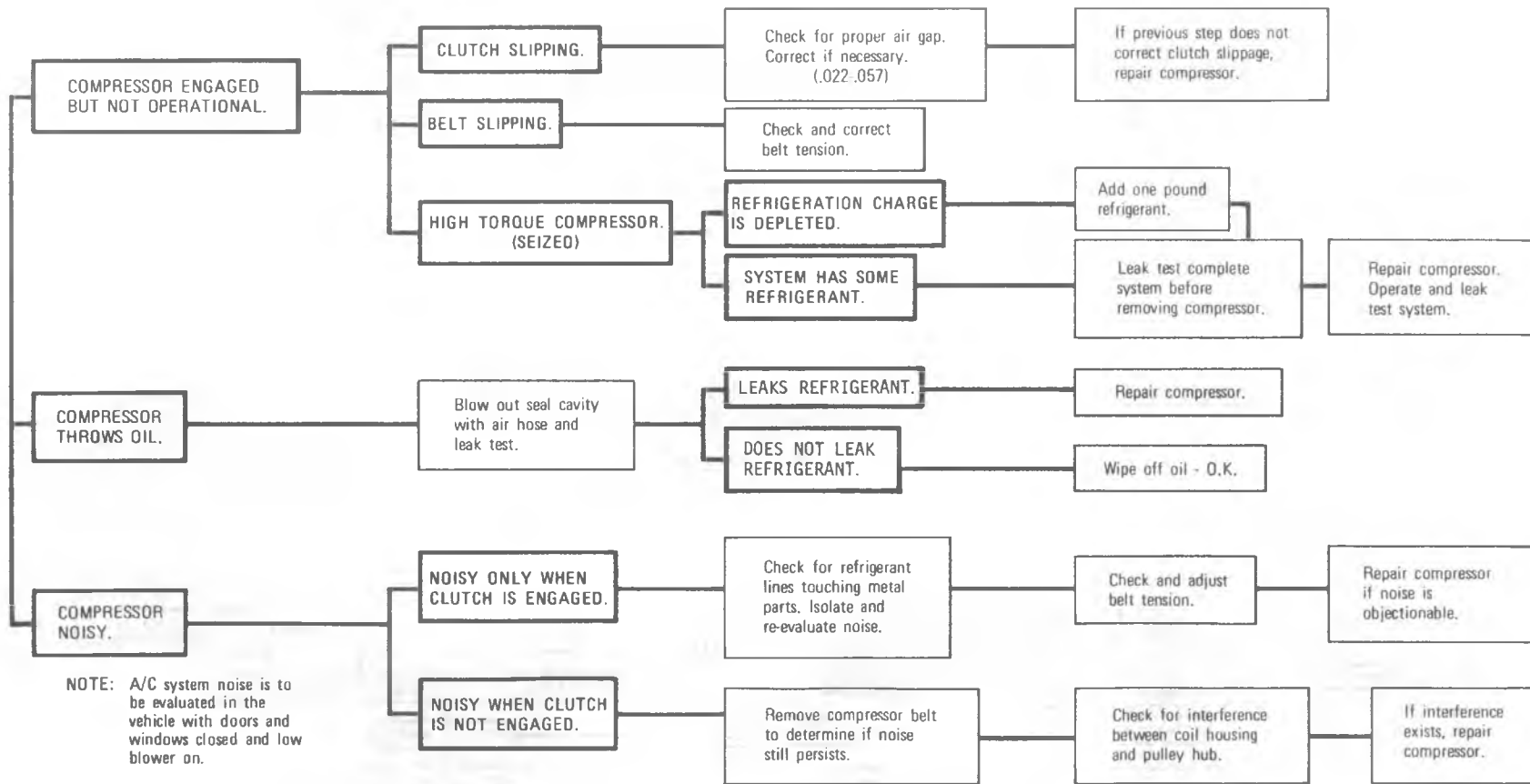

NOTE: A/C system noise is to be evaluated in the vehicle with doors and windows closed and low blower on.

### INSUFFICIENT COOLING DIAGNOSIS CHART DASH MOUNTED UNIT (MOTOR HOME CHASSIS UNITS)

- The following procedures should be applied before performance testing an A/C System.
1. Check for proper belt installation and tension with J-23600.
  2. Check for proper clutch coil terminal connector installation.
  3. Check for clutch air Gap (.022 - .057).
  4. Check for broken, burst, or cut hoses. Also check for loose fittings on all components.
  5. Check for condenser air blockage due to foreign material.
  6. Check for proper air ducting hose connections.
  7. Check heater temperature door adjustment, adjust if incorrect.
  8. Check evaporator sealing for air leak, repair if leaking.
  9. Install pressure gages and thermometer and make performance test.

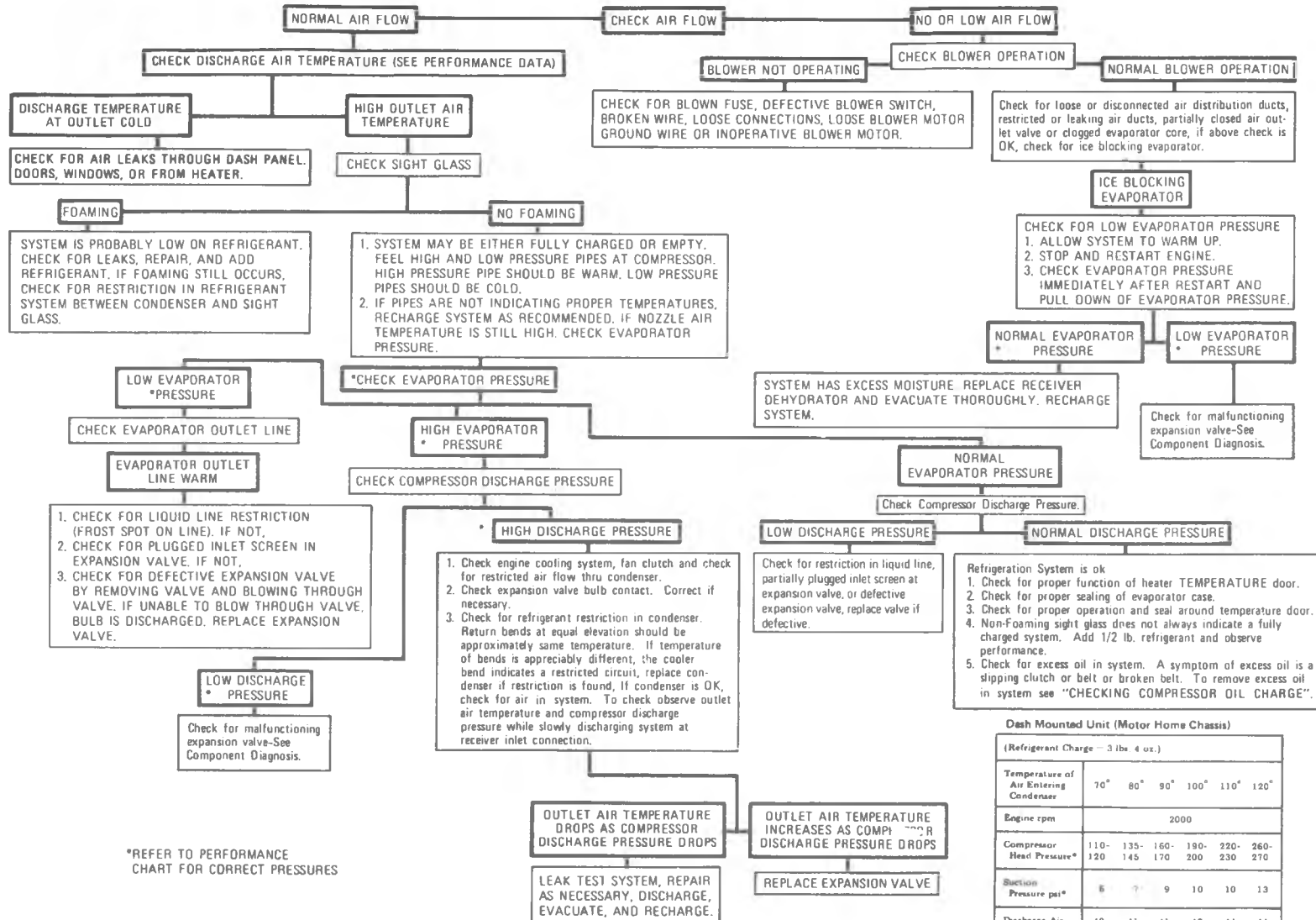

Dash Mounted Unit (Motor Home Chassis)

| (Refrigerant Charge - 3 lbs. 4 oz.)   |         |         |         |         |         |         |
|---------------------------------------|---------|---------|---------|---------|---------|---------|
| Temperature of Air Entering Condenser | 70°     | 80°     | 90°     | 100°    | 110°    | 120°    |
| Engine rpm                            | 2000    |         |         |         |         |         |
| Compressor Head Pressure*             | 110-120 | 135-145 | 160-170 | 190-200 | 220-230 | 260-270 |
| Suction Pressure psi*                 | 5       | 7       | 9       | 10      | 10      | 13      |
| Discharge Air Temperature*            | 40-45   | 41-46   | 41-46   | 42-47   | 44-47   | 44-49   |

\*Just prior to compressor clutch disengagement.

## ELECTRICAL SYSTEM DIAGNOSTIC CHART

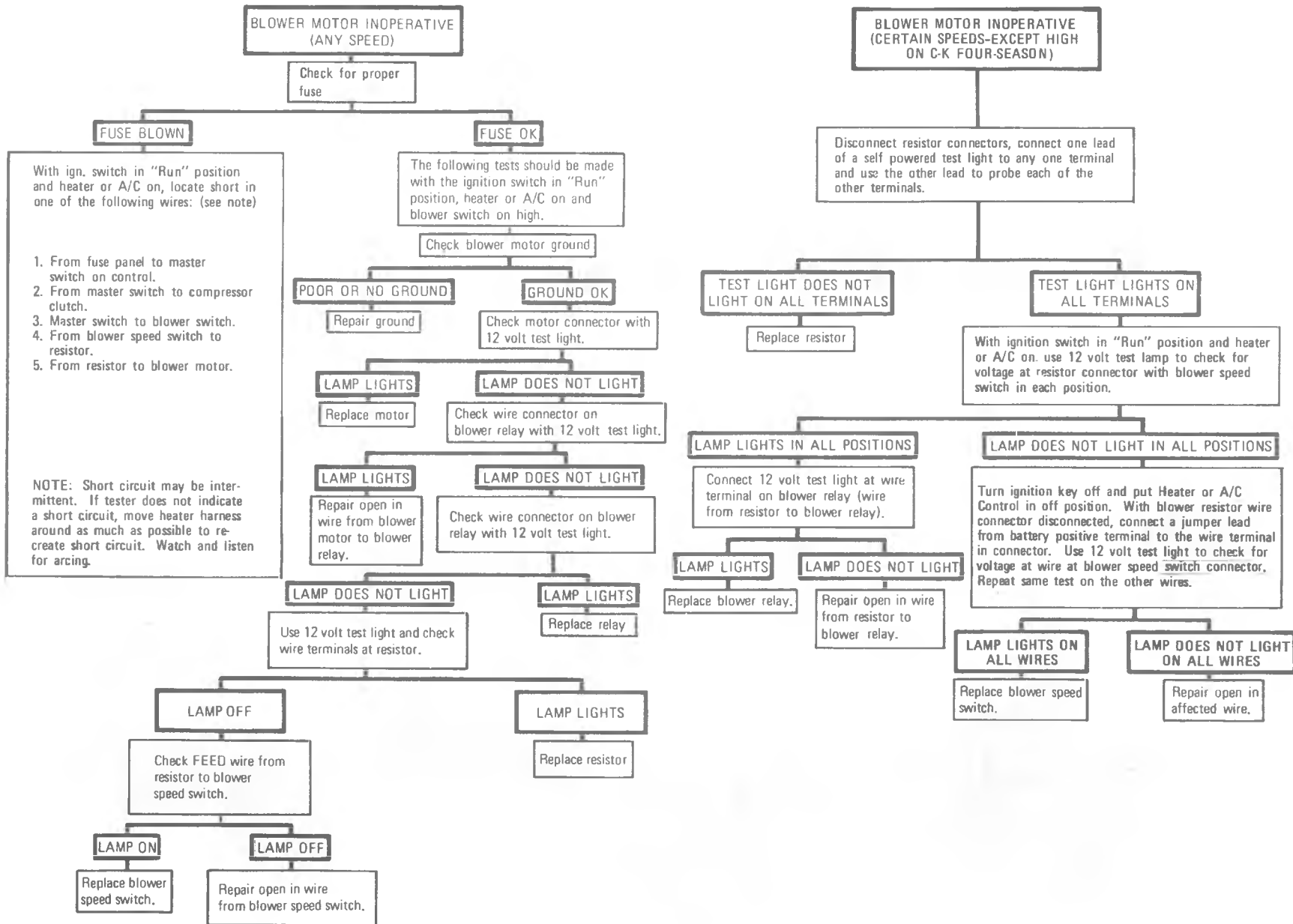

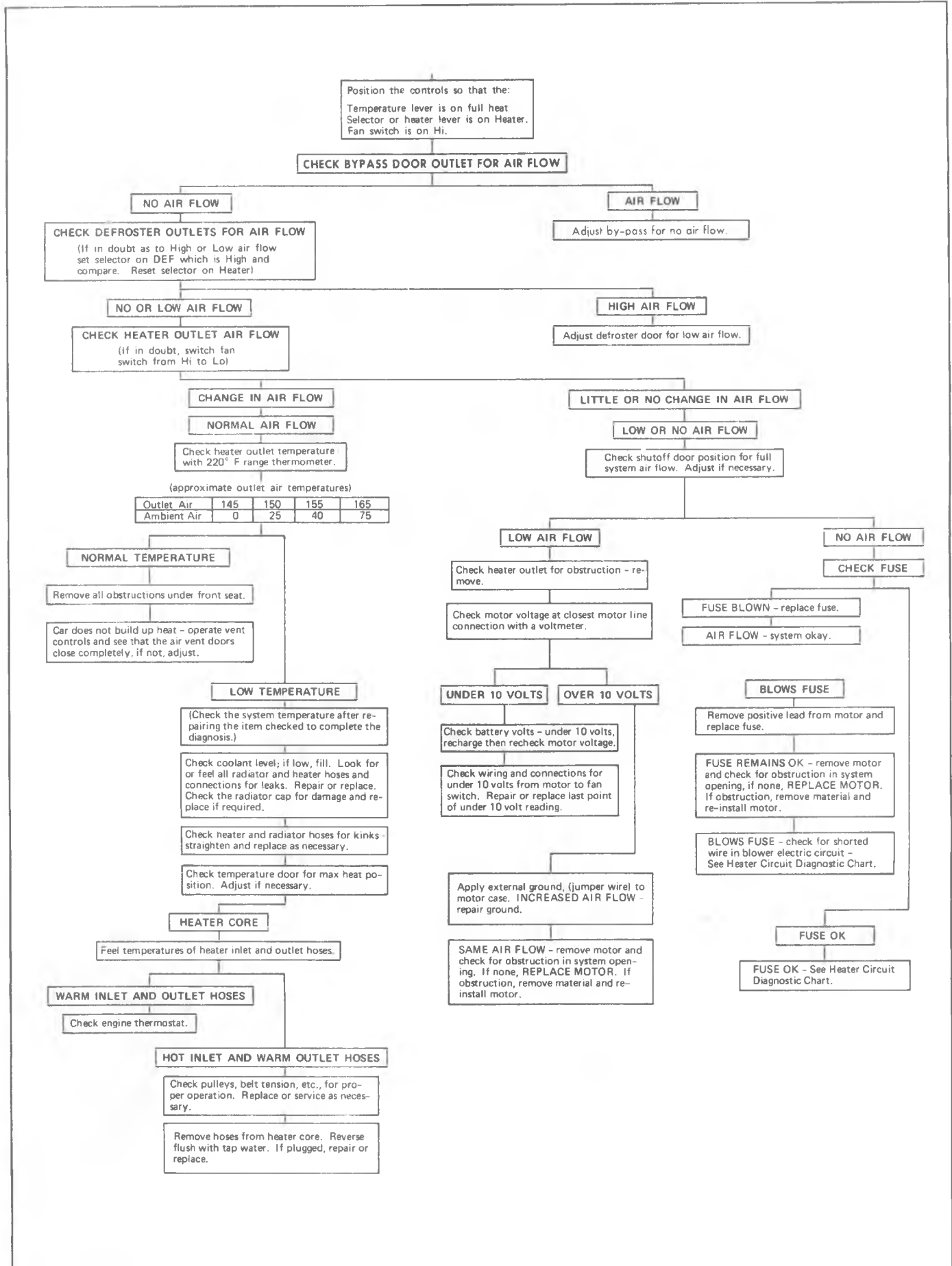

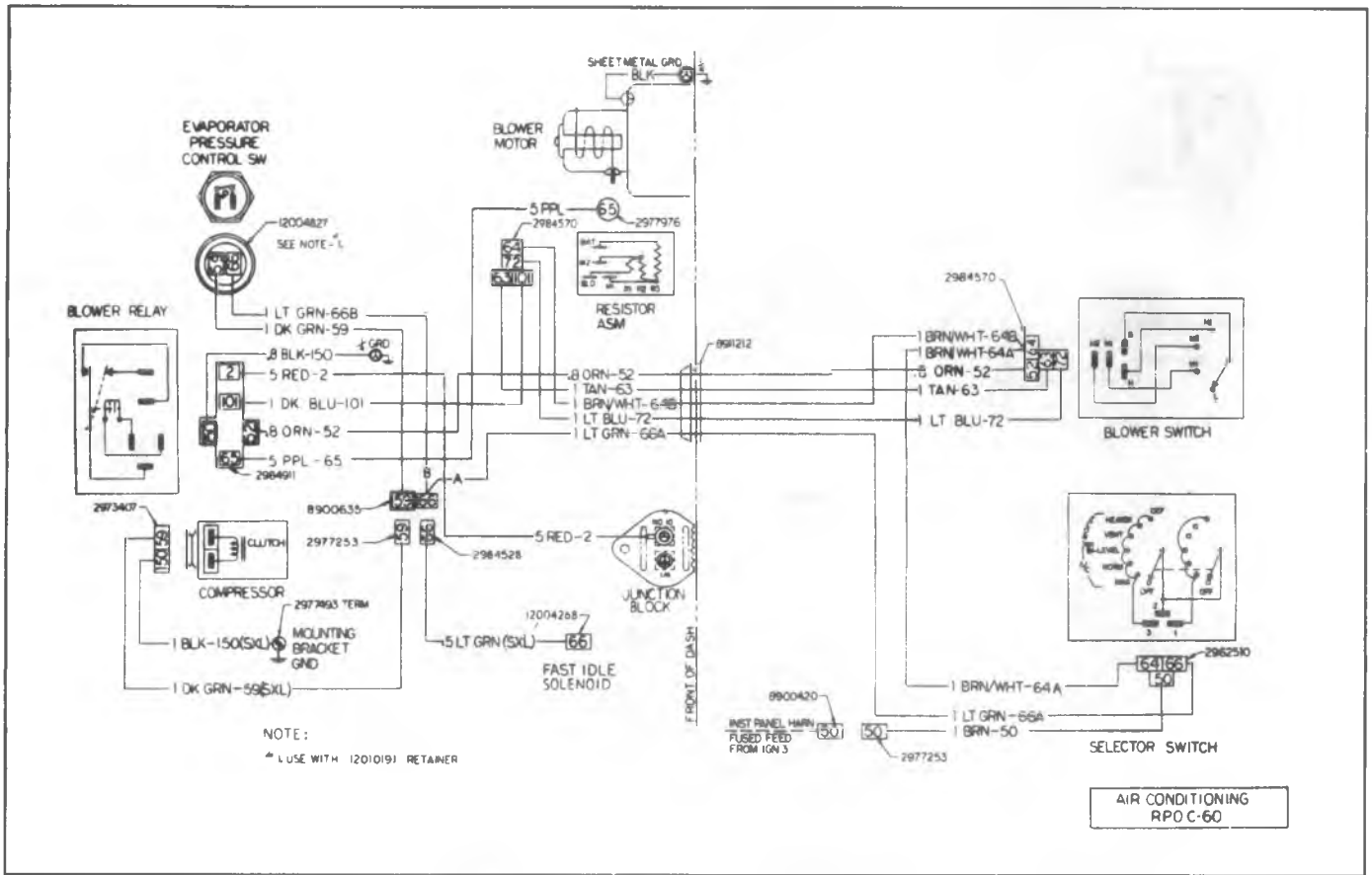

Fig. 1B-14--C60 System Wiring Diagram (C-K Series)

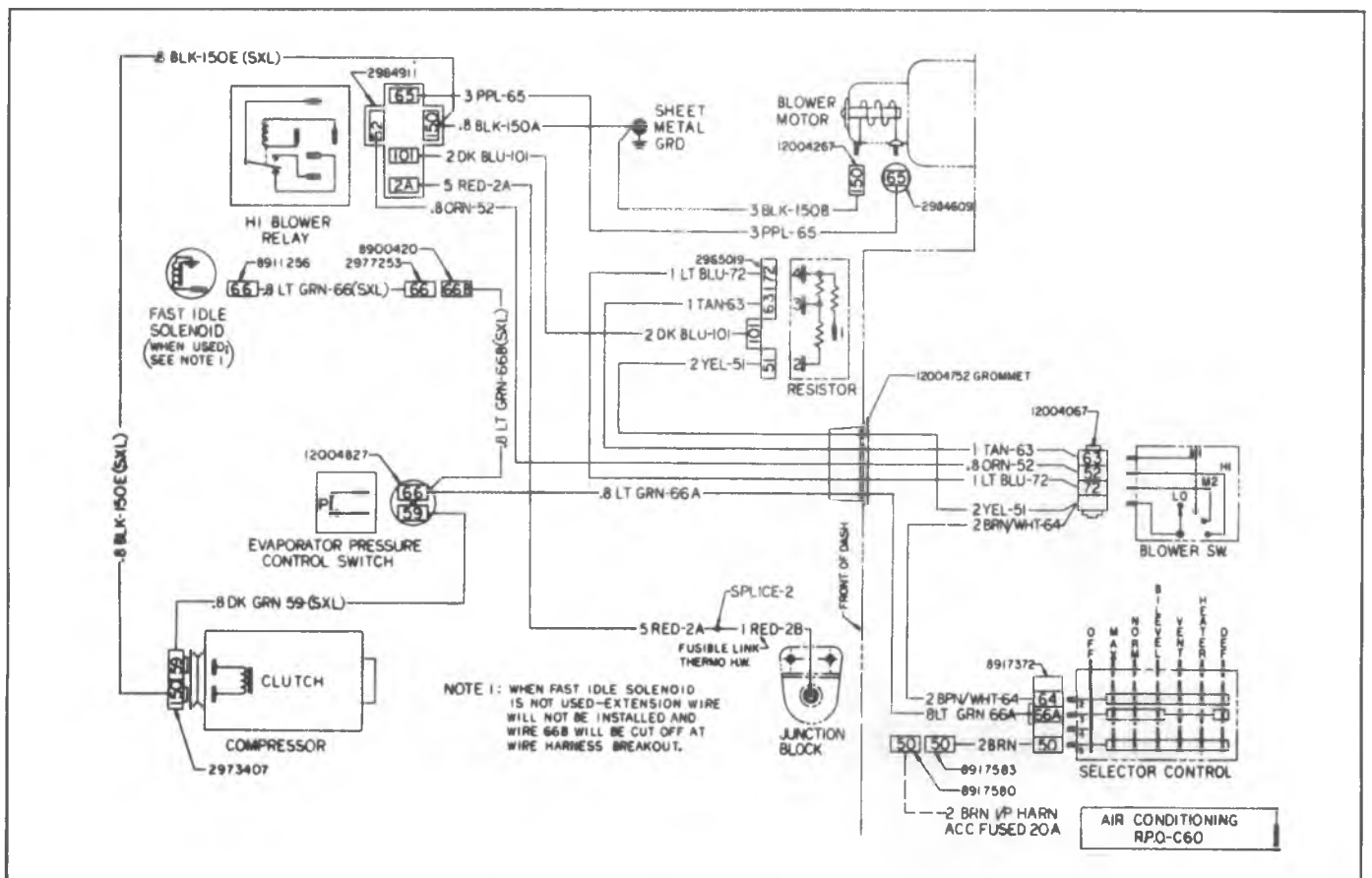

Fig. 1B-15--C60 System Wiring Diagram (G Series)

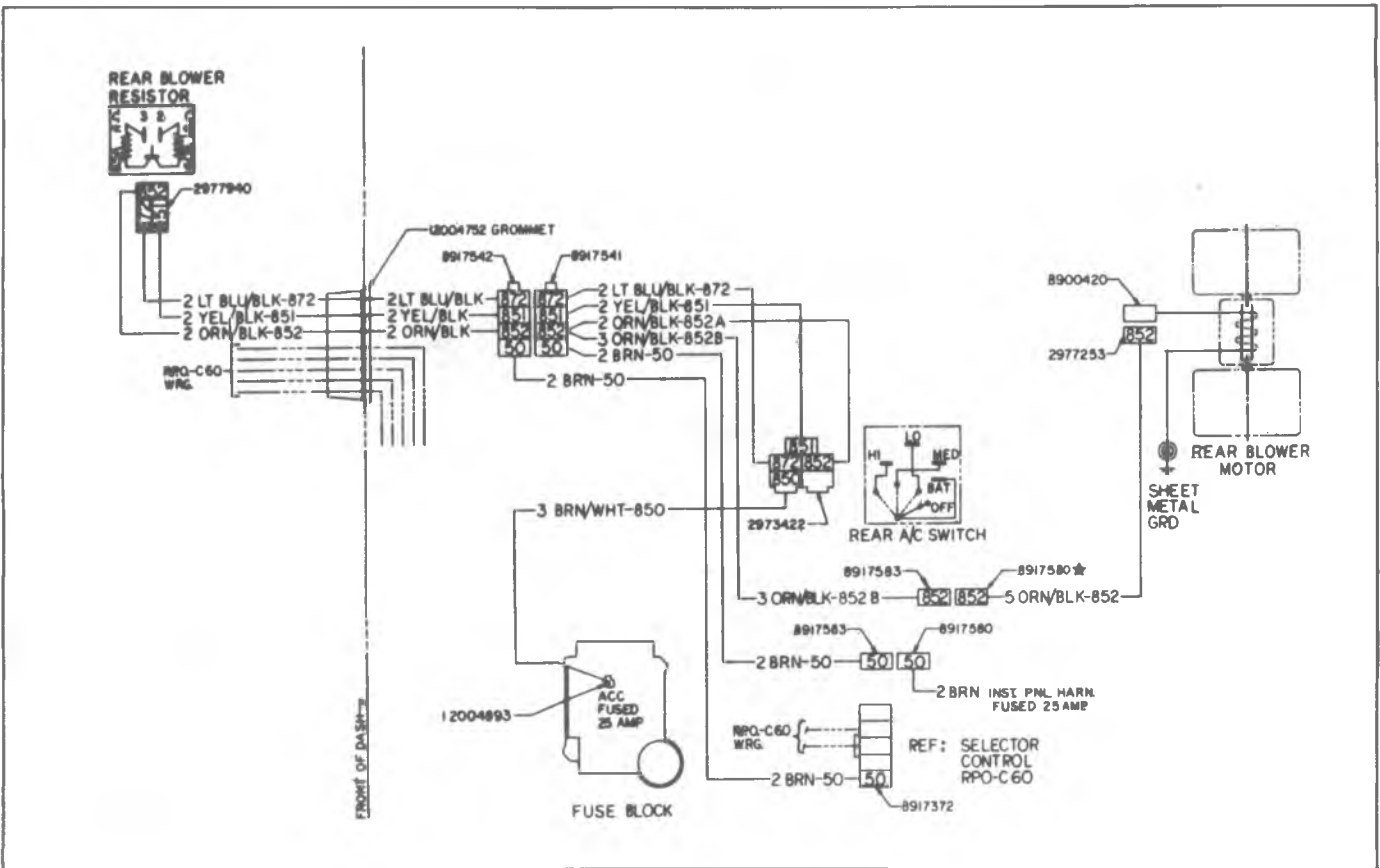
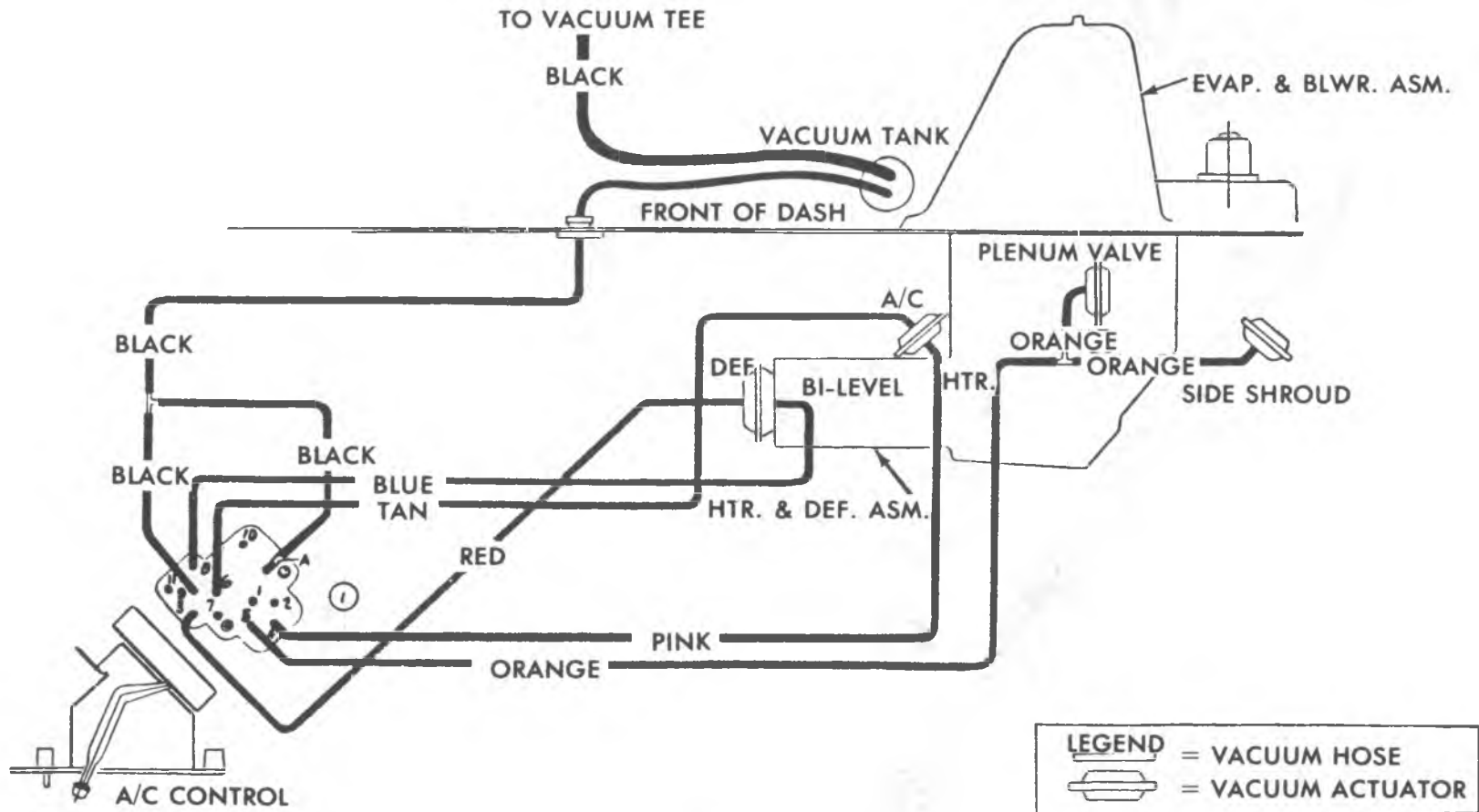

Fig. 1B-16--Overhead Systems Wiring Diagrams-All



Fig. 1B-17-C60 System Vacuum Diagram (C-K Series)



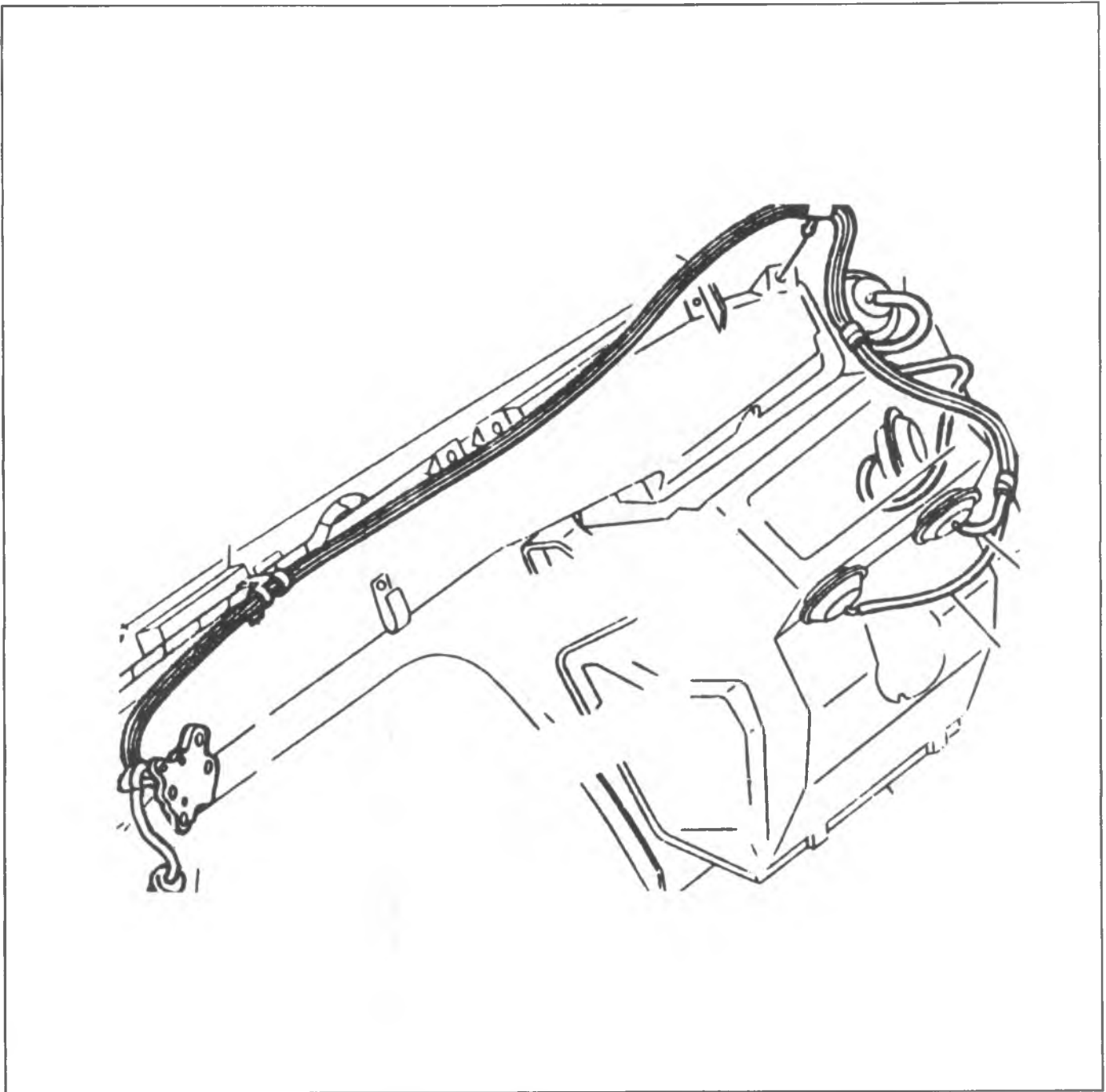
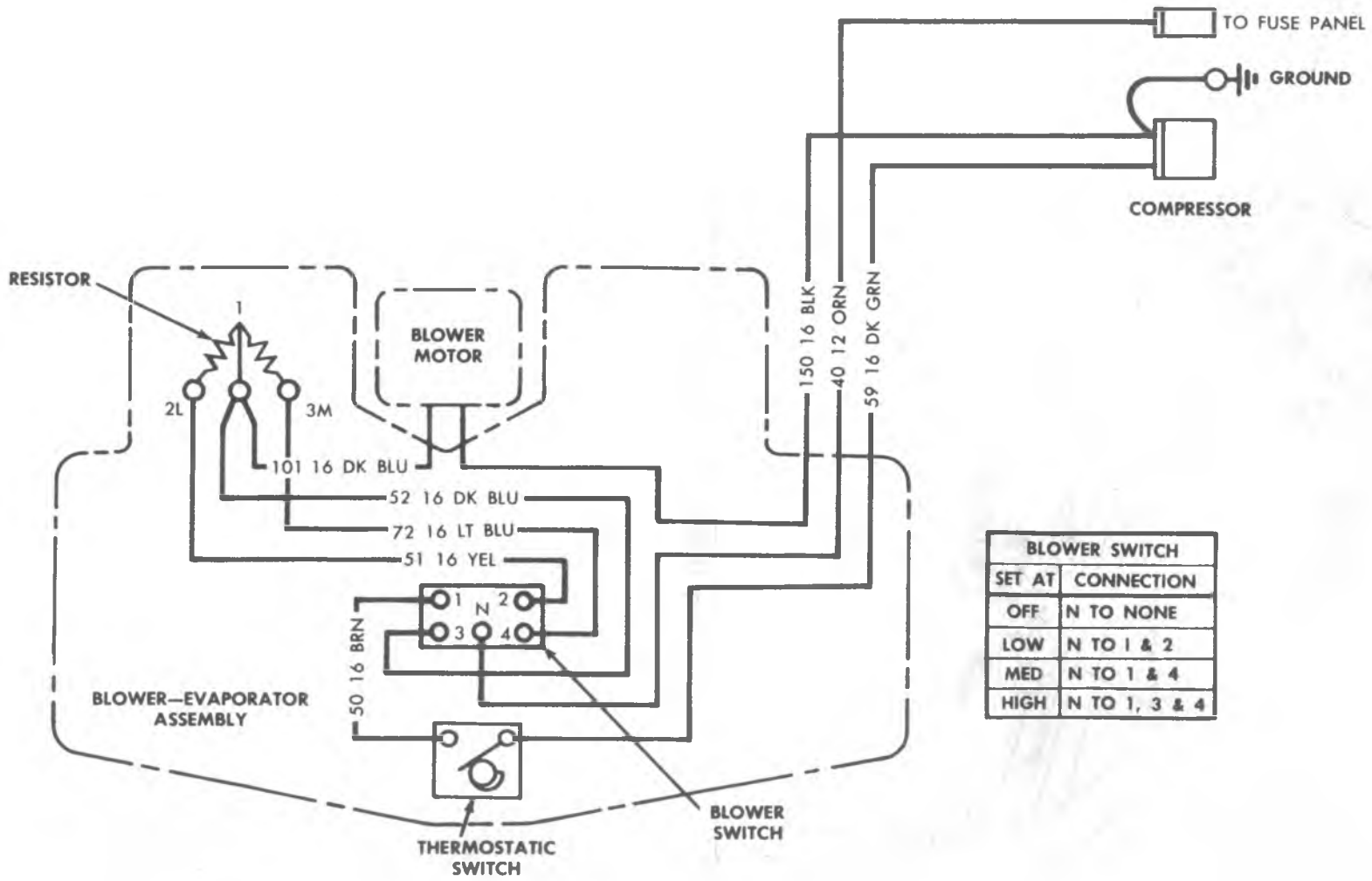

Fig. 1B-18--C60 System Vacuum Diagram (G Series)

Fig. 1B-19--C60 Motor Home Chassis Wiring Diagram



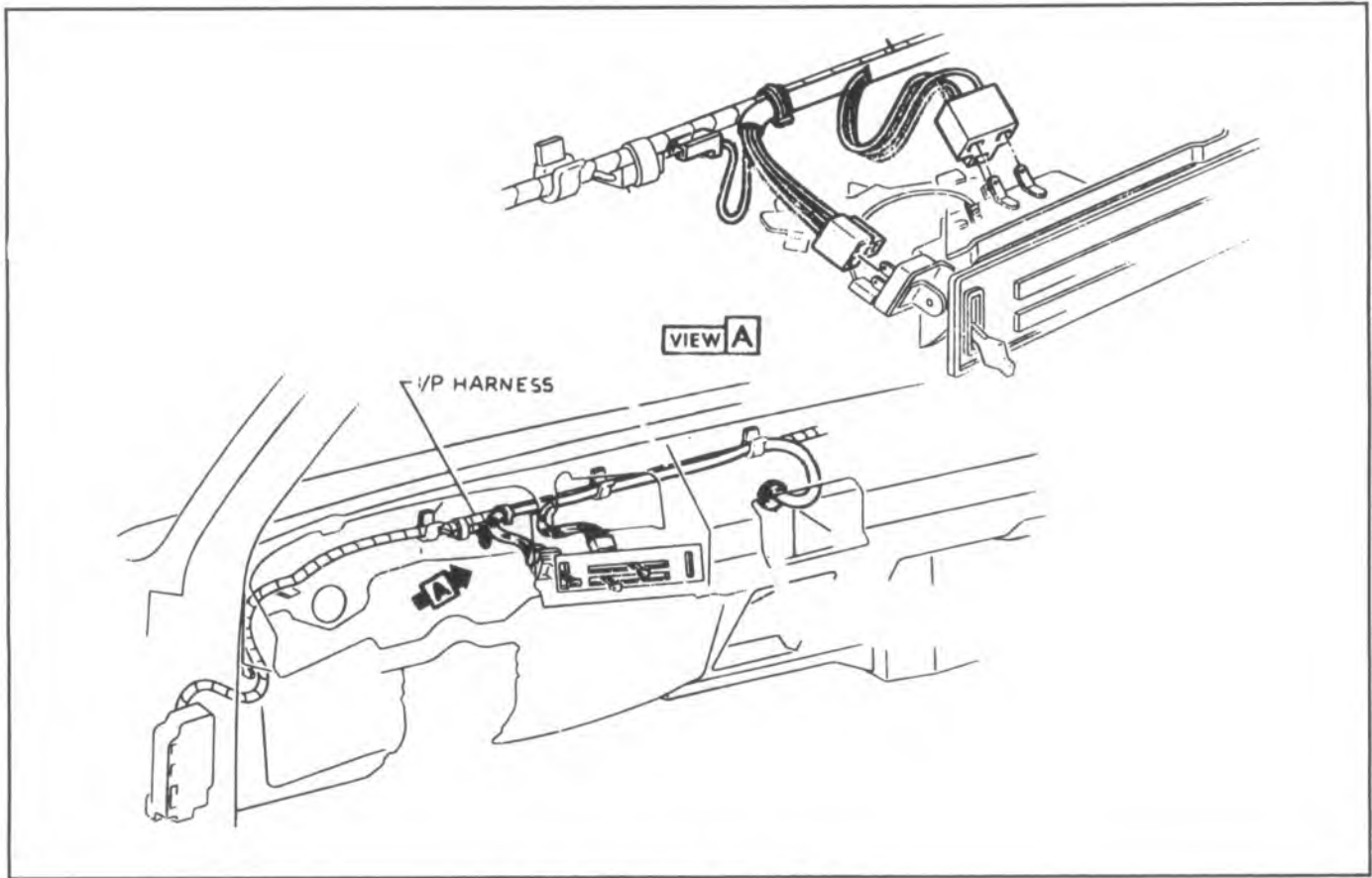

Fig. 1B-20--I.P. A/C Harness Wiring

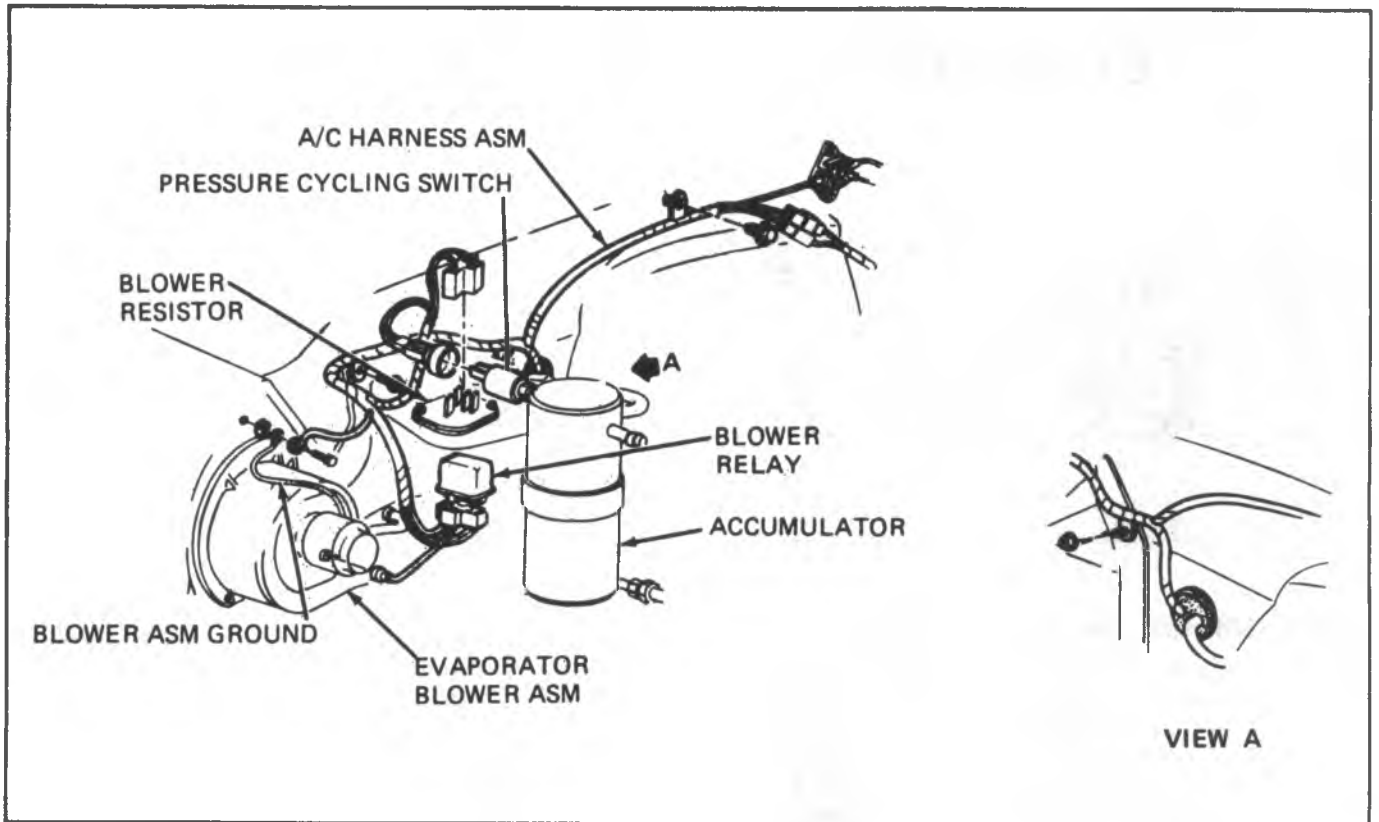

Fig. 1B-21-A/C Compressor wiring

## ON VEHICLE SERVICE EVACUATING AND CHARGING PROCEDURES

| METAL TUBE<br>OUTSIDE<br>DIAMETER | THREAD AND<br>FITTING SIZE | STEEL<br>TUBING<br>TORQUE |       | ALUMINUM OR<br>COPPER<br>TUBING<br>TORQUE |       | NOMINAL<br>TORQUE<br>WRENCH SPAN |
|-----------------------------------|----------------------------|---------------------------|-------|---|-------|----------------------------------|
|                                   |                            | LB. FT.                   | N'm   | LB. FT.                                   | N'm   |                                  |
| 1/4                               | 7/16                       | 10-15                     | 14-20 | 5-7                                       | 7-9   | 5/8                              |
| 3/8                               | 5/8                        | 30-35                     | 41-48 | 11-13                                     | 15-18 | 3/4                              |
| 1/2                               | 3/4                        | 30-35                     | 41-48 | 15-20                                     | 20-27 | 7/8                              |
| 5/8                               | 7/8                        | 30-35                     | 41-48 | 21-27                                     | 28-37 | 1 1/16                           |
| 3/4                               | 1 1/16                     | 30-35                     | 41-48 | 28-33                                     | 38-45 | 1 1/4                            |

### PRECAUTIONARY SERVICE MEASURES

Before any service is attempted which requires opening of refrigerant lines or components, the person doing the work should be thoroughly familiar with the information under PRECAUTIONS IN HANDLING Refrigerant-12, PRECAUTIONS IN HANDLING REFRIGERANT LINES AND FITTINGS MAINTAINING CHEMICAL STABILITY IN THE REFRIGERATION SYSTEM, AND REFRIGERANT CHARGING PRECAUTIONS and should follow very carefully the DISCHARGING, EVACUATING, OIL ADDITION AND CHARGING THE REFRIGERANT SYSTEM instructions given on the following pages for the unit being serviced.

Sealing caps should be removed from subassemblies just prior to making connections for final assembly. Use a small amount of clean 525 viscosity refrigerant oil on all tube and hose joints. Always use new "O" rings dipped in the clean 525 viscosity refrigerant oil when assembling joints. The oil will aid in assembly and help provide a leak-proof joint. When tightening joints, use a second wrench to hold stationary part of connection so that a solid feel can be attained. This will indicate proper assembly.

Tighten all tubing connections, as shown in torque Chart 1B-8. Insufficient or excessive torque when tightening can result in loose joints or deformed joint parts. Either condition can result in refrigerant leakage.

### DISCHARGING EVACUATING ADDING OIL AND CHARGING PROCEDURES FOR CCOT A/C SYSTEMS

The refrigerant system may be Discharged, Evacuated and Charged using J-23500-01 air conditioning service Charging Station or the J-5725-04 Manifold and Gage Set, and 420 ml-14 oz. disposable cans of Refrigerant-12.

Charging lines from the Charging Station or Manifold and Gage Set require the use of gage adapters to connect to the system service fittings. A straight gage Adapter J-5420 and a 90° angle gage Adapter J-9459 are available (See A/C Special Tools).

Always wear goggles and wrap a clean cloth around fittings and connections when doing work that involves

opening the refrigeration system. If liquid refrigerant comes into contact with the skin or eyes injury can result.

- Before removing and replacing any of the air conditioning refrigeration lines or components, the system must be completely discharged of Refrigerant-12.
- Always use service valve and pressure gage sets during evacuation and charging procedures.
- Do not charge while compressor system is hot.
- Always discharge system at low-side service fitting and perform the entire evacuate and charging procedure through the low-side service fitting.
- Do not connect high pressure line or any line to the high-side service fitting during discharging and charging procedures.

**CAUTION: Never remove a gage line from its adapter when line is connected to A/C system. Always remove the line adapter from the service fitting to disconnect a line. Do not remove charging hose at gage set while attached to service low-side fitting. This will result in complete discharge of system due to the depressed schrader valve in service low-side fitting and may cause personal injury due to escaping Refrigerant-12.**

### DISCHARGING THE CCOT A/C SYSTEM

In replacing any of the air conditioning refrigeration components the system must be completely discharged of Refrigerant-12.

Always discharge system at low side service fitting.

1. With ignition turned OFF, remove protective cap from LOW-SIDE service fitting and connect Charging Station J-23500-01 Gage Set as indicated in Figure 1B-12.

If charging station J-23500-01 is not being used, discharge system by slowly connecting a gage hose to low-side service fitting on Accumulator and discharging into oil bottle (Fig. 1B-12). As hose is SLOWLY tightened down onto schrader valve, Refrigerant-12 will be in to discharge from the system into the container. If no discharge occurs, check for missing or defective schrader depressor in hose fitting.

2. With the low-side of system fully discharged, check high-side system fitting (on liquid line or muffler) for remaining pressure.
3. If pressure is found, attempt to discharge high-side using same procedure as used for low-side. (This condition indicates a restriction on the high-side and the cause must be diagnosed and corrected before evacuating and charging the system).
4. When the system is completely discharged (no vapor escaping with hose fully-tightened down), measure, record amount and discard the collected refrigerant oil. If this quantity is 15 ml (1/2 oz.) or more, this amount of new 525 viscosity refrigerant oil must be added to system, plus any quantity in removed parts before evacuation and charging with Refrigerant-12 (Refer to CCOT Refrigerant Oil Distribution for specific quantity of oil normally retained in removed parts).

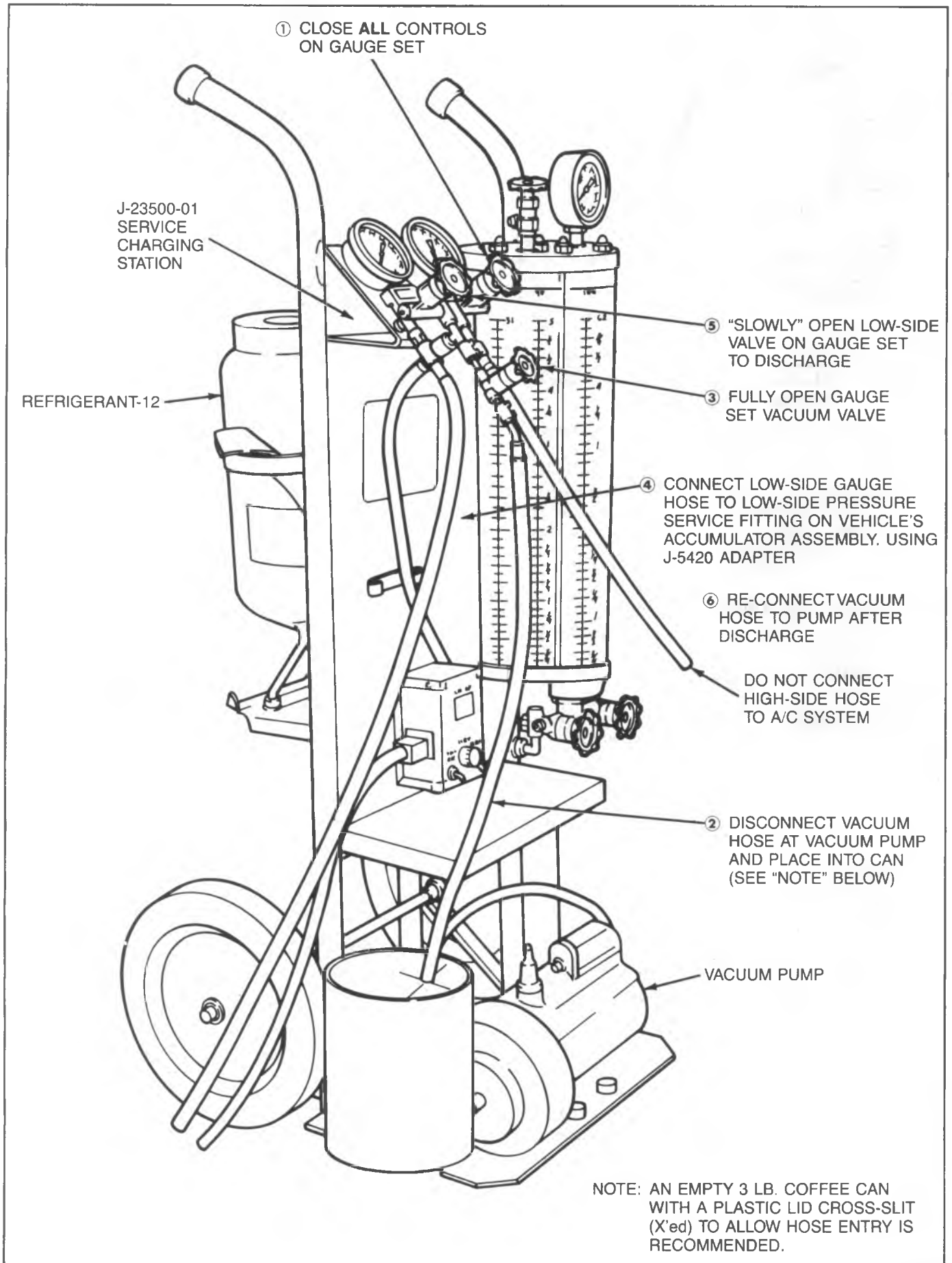

Fig. 1B-22--Discharging The CCOT System With J-23500-01 Charging Station

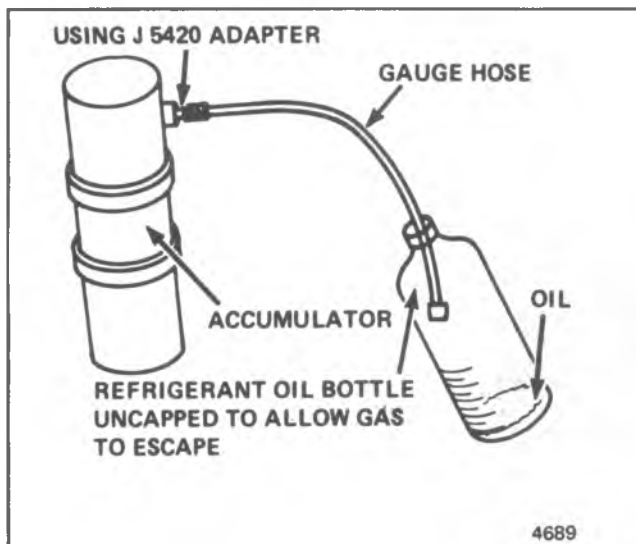

Fig. 1B-23--Discharging the CCOT A/C System Without Charging Station J-23500-01

Distribution for specific quantity of oil normally retained in removed parts).

5. If adding oil is necessary, remove the suction hose at the accumulator outlet pipe connection and pour the correct quantity of refrigerant oil into the hose or pipe and then properly reconnect hose or pipe. (See Discharging Step No. 4 and C.C.O.T. Refrigerant Oil Distribution for specific quantity instructions).

### CCOT REFRIGERANT OIL DISTRIBUTION

A-6 COMPRESSOR -- requires 300 ml (10 oz.) of 525 viscosity refrigerant oil.

R-4 COMPRESSOR -- requires 6 oz. (180 ml) of 525 viscosity refrigerant oil.

New oil quantities must be added to the system during Service component replacement and conditions stated as follows:

- A. WHEN THERE ARE NO SIGNS of excessive oil leakage, for:
  - Compressor - Remove, drain oil, measure, replace same amount of new oil plus 1 oz. (30 ml). On A-6 compressor, if amount of oil drained is 240 ml (8 oz.) or more, an oil overcharge should be suspected.
  - Evaporator - Add 90 ml (3 oz.).
  - Condenser - Add 30 ml (1 oz.).
  - Accumulator - Remove, drain oil, measure, replace same amount of new oil plus 60 ml (2 oz.) to compensate for that retained by the original accumulator dessicant.
- B. WITH SIGNS OF EXCESSIVE OIL LEAKAGE, for:

#### A-6 Compressor Systems

Remove Compressor AND Accumulator. Drain, measure and record TOTAL oil from both components. Discard old oil.

If less than 180 ml (6 oz.), add 180 ml (6 oz.) of new oil to system.

If more than 180 ml (6 oz.), add same amount of new oil as drained.

If a new Accumulator must be added to A-6 system, add 2 additional ounces (60 ml) of oil to compensate for that held/absorbed by the original accumulator dessicant.

#### R-4 Compressor Systems

- A. With no signs of excessive oil leakage, add:
  - Compressor - Remove, drain oil, measure, replace same amount of new oil plus 30ml (1 fl. oz).
  - Evaporator - Add 90ml (3 fl. oz).
  - Condenser - Add 30 ml (1 fl. oz).
  - Accumulator - Remove, drain oil, measure, replace same amount of new oil plus 60ml (2 fl. oz) to compensate for that retained by the original accumulator dessicant.
- B. With signs of excessive oil leakage:
  - Remove only the Accumulator. Drain, measure and record quantity of oil in Accumulator. It is not necessary to remove and drain the R-4 Compressor because the Compressor only retains a minimum quantity of oil.
  - If less than 90ml (3 fl. oz), add 90ml (3 fl. oz) of new oil to system.
  - If more than 90ml (3 fl. oz), add same amount of new oil as drained.
  - If a new Accumulator must be added to R-4 system, add 60ml (2 fl. oz) additional oil, to compensate for that held/absorbed by the original Accumulator dessicant.

### EVACUATING AND CHARGING THE CCOT A/C SYSTEM

If the system has been opened for any repair, or the Refrigerant-12 charge lost, the system must be evacuated prior to charging.

Evacuation and Charging is a combined procedure, and all gage lines must be purged with Refrigerant-12 prior to charging.

There are three standard Refrigerant-12 evacuate and charge procedures:

- J-23500-01 Charging Station Method
- Disposable Can Method
- Drum Method

**NOTICE:** Under no circumstances should alcohol be used in the system in an attempt to remove moisture. Damage to the system components could occur.

### GAGE CALIBRATION

Prior to Evacuation, check the low pressure gage for proper calibration and determine if vacuum system is operating properly. With the gage disconnected from the refrigeration system, be sure that the pointer indicates to the center of "O". Lightly tap gage a few times to be sure pointer is not sticking. If necessary, calibrate as follows:

- a. Remove cover from gage.
- b. Holding gage pointer adjusting screw firmly with one hand, carefully force pointer in the proper direction to position pointer at the "O" position. Tap gage a few times to be sure pointer is not sticking. Replace gage cover.

### VACUUM SYSTEM CHECK

Before connecting vacuum pump to the A/C system, run pump connected to the low pressure gage to determine



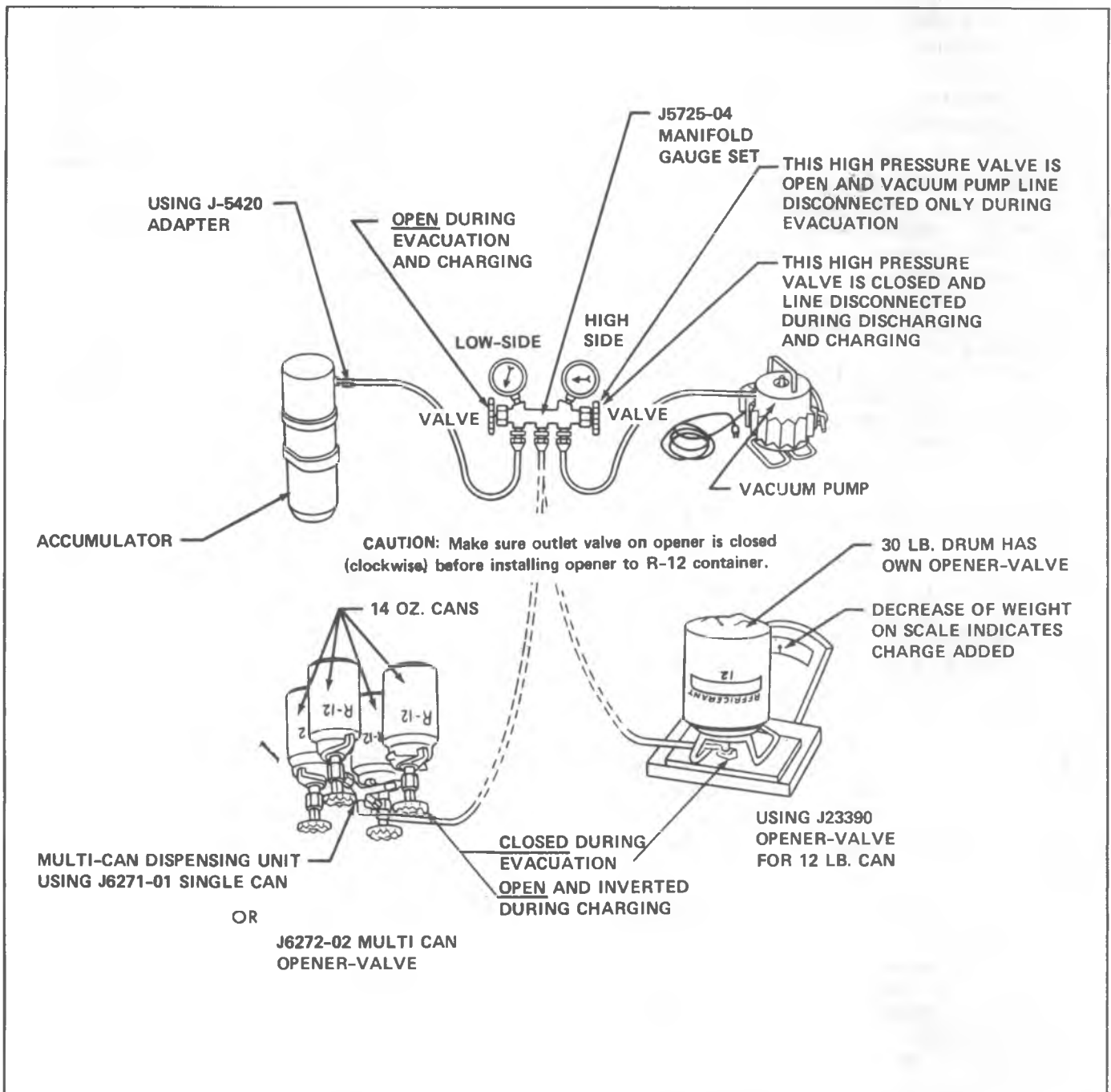

Fig. 1B-24--Charging the CCOT A/C System with Disposable Can or Refrigerant Drum.

vacuum pump capability. If the vacuum system is unable to reach 711.2-736.6mm (28"-29") or more vacuum, the system should be checked for leaks. If no leaks are found, the vacuum pump may require repair.

### J-23500-01 CHARGING STATION METHOD

Follow Charging instructions provided with the J-23500-01 Charging Station in use with the following exceptions:

1. Do not connect the high pressure line to the air conditioning system.
2. Keep the high pressure valve on the charging station closed at all times.
3. Perform the entire evacuate and charge procedure through the accumulator low-side pressure service fitting.

4. Following these procedures will prevent accidental high-side vehicles system pressure being subjected to the Charging Station in the event an error is made in valve sequence during compressor operation to pull in the Refrigerant-12 charge.

### DISPOSABLE CAN OR REFRIGERANT DRUM METHOD

- If the Refrigerant-12 drum is used, place it on a scale and note the total weight before Charging. Watch the scale during Charging to determine the amount of Refrigerant-12 used.
- If disposable 420 ml (14 oz.) Refrigerant-12 cans are used, close the tapping valve and then attach

can(s) following instructions included with the tapping valve or tapping manifold adapter.

1. Connect Manifold Gage Set J-5725-04 as follows. Also see Fig. 1B-12.
  - Low pressure gage set valve to Accumulator fitting
  - Gage set center hose to Refrigerant-12 source
  - High pressure gage to vacuum pump

2. To begin evacuation of the A/C system, with Manifold Gage Set and Vacuum Pump as illustrated in Fig. 1B-13, SLOWLY open high and low-side gage valves and begin vacuum pump operation. Pump the system until the low-side gage reaches 711.2 - 736.6mm (28 to 29 in.) mercury (vacuum) or more.

Note that in all Evacuation procedures, the specification of 711.2 - 736.6mm (28 to 29 in.) of mercury vacuum is used. This specification can only be reached at or near sea level. For each 304.8m (1,000 feet) above sea level, specification should be lowered by one inch of vacuum. At 1524m (5,000) feet elevation only 584.2 - 609.6mm (23 to 24 in.) of mercury (vacuum) is required.

If prescribed mercury (vacuum) cannot be reached, close vacuum control valve, shut off pump and look for a leak at connections or pump.

3. When the gage reaches prescribed vacuum, the system is fully evacuated. Close the high-side gage set valve and turn OFF the vacuum pump.
4. Watch low-side gage to be sure vacuum holds for five (5) minutes. If vacuum is held, disconnect vacuum hose at gage set and then proceed to charging.
5. If vacuum does not hold for five (5) minutes, charge system with 420 ml (1/2 lb.) Refrigerant-12 and leak check. Discharge system again then repair leak as necessary. Repeat Evacuation procedure.

### TO BEGIN CHARGING OF THE CCOT A/C SYSTEM

1. Start engine, run with choke open and fast idle speed reduced to normal idle, set A/C control lever on OFF.
2. With the Refrigerant-12 drum or 420 ml (14 oz.) can(s) inverted, open Refrigerant-12 source valve(s) and allow 480 ml (one (1) pound) or one 420 ml (14 oz.) can of liquid Refrigerant-12 to flow into system through low-side Service fitting on Accumulator (Refer to Fig. 1B-12).
3. As soon as 480 ml (1 lb.) or one 420 ml (14 oz.) can of liquid Refrigerant-12 has been added to system, immediately engage the compressor, by setting the A/C control lever to NORM and blower speed on HI, to draw in the remainder of the Refrigerant-12 charge. The Charging operation can be speeded up by using a large volume fan to pass air over the condenser. If condenser temperature is maintained below charging cylinder temperature, Refrigerant-12 will enter system more rapidly.
4. Shut off Refrigerant-12 source valve and run engine for 30 seconds to clear lines and gages.
5. With the engine running, remove the charging low-side hose adapter from the Accumulator Service fitting. Unscrew rapidly to avoid excess Refrigerant-12 escape from system.

**CAUTION:** Never remove a gage line from its adapter when line is connected to A/C system. Always remove the line adapter from the service fitting to disconnect a line. Do not remove charging hose at gage set while attached to accumulator. This will result in complete discharge of system due to the depressed schrader valve in service low-side fitting, and may cause personal injury due to escaping Refrigerant-12.

6. Replace protective cap on Accumulator fitting.
7. Turn engine off.
8. Leak check system with J-6084 Leak Detector.
9. Start engine.
8. With system fully Charged and leak-checked, continue to operate system and test for proper system pressures as outlined under PERFORMANCE CONDITIONS AND PERFORMANCE PRESSURE-TEMPERATURE DATA in Charts 1B-4 and 1B-5.

### ACCUMULATOR ASSEMBLY

The accumulator assembly for the CCOT system has a service replacement which includes two "O" rings (for the inlet and outlet connections). The desiccant within the shell is NOT serviced separately - it is part of the sealed accumulator assembly. See CCOT Refrigerant Oil and Distribution for presence of refrigerant oil and service conditions when the accumulator must be removed from the vehicle to measure the amount of oil present inside the accumulator.

The accumulator assembly should ONLY be replaced when:

1. A physical perforation to the accumulator is found resulting in a leak.
2. The expansion (orifice) tube screen experiences continued or repeated plugging.
3. The compressor inlet screen is plugged (A6 compressor).
4. An evaporator fails because of inside-out (internal corrosion).

DO NOT REPLACE the accumulator assembly where:

1. Merely a dent is found in the outer shell of the accumulator.
2. A vehicle is involved in a collision and no physical perforation to the accumulator is found. An open refrigerant line should be capped or have a plastic bag tightly taped around it.

### ACCUMULATOR REPLACEMENT

1. Disconnect battery ground cable.
2. Discharge system of refrigerant.
3. Disconnect accumulator inlet and outlet connections. Cap or plug open lines immediately.
4. Remove accumulator attaching screws and check amount of oil in accumulator and install this amount of fresh 525 viscosity refrigerant oil into new accumulator plus 60 ml (2 oz.)
5. Install new accumulator, using clean 525 viscosity refrigerant oil on "O" rings.
6. Evacuate and recharge system.

## EXPANSION TUBE (ORIFICE)

### Removal and Installation

1. Discharge the refrigerant from the system.
2. Disconnect liquid line at evaporator inlet and remove expansion tube (orifice) from the inlet pipe.
3. To install, reverse the above procedure. When installing the expansion tube (orifice) inside the evaporator inlet pipe, it **MUST** be installed with "shorter screen end" inserted first.

## SPECIFIC COMPONENT DIAGNOSIS

The following is a description of the type of symptom each refrigerant component will evidence if a defect occurs:

### COMPRESSOR

A compressor defect will appear in one of four ways: Noise, seizure, leakage, or low discharge pressure.

**NOTICE:** Resonant compressor noises are not cause for alarm; however, irregular noise or rattles may indicate broken parts or excessive clearances due to wear. To check seizure, de-energize the magnetic clutch and check to see if drive plate can be rotated. If rotation is impossible, compressor is seized (Refer to "False Compressor Seizure"). To check for a leak, refer to leak testing. Low discharge pressure may be due to a faulty internal seal of the compressor, or a restriction in the compressor.

**NOTICE:** Furthermore, low discharge pressure may be due to an insufficient refrigerant charge or a restriction elsewhere in the system. These possibilities should be checked prior to servicing the compressor. If the compressor is inoperative, but is not seized, check to see if current is being supplied to the magnetic clutch coil terminals.

### CONDENSER

A condenser may be defective in two ways: it may leak, or it may be restricted. A condenser restriction will result in excessive compressor discharge pressure. If a partial restriction is present, sometimes ice or frost will form immediately after the restriction as the refrigerant expands after passing through the restriction. If air flow through the condenser or radiator is blocked, high discharge pressures will result. During normal condenser operation, the outlet pipe will be slightly cooler than the inlet pipe.

### RECEIVER-DEHYDRATOR - MOTOR HOME CHASSIS

A defective receiver-dehydrator may be due to a restriction inside the body of the unit. A restriction at the inlet to the receiver-dehydrator will cause high head pressures. Outlet tube restrictions will be indicated by low head pressures and little or no cooling. An excessively cold receiver-dehydrator outlet may be indicative of a restriction.

### EXPANSION VALVE

A malfunction of the expansion valve will be caused by one of the following conditions: valve stuck open, valve stuck closed, broken power element, a restricted screen or an improperly located or installed power element bulb. The

first three conditions require valve replacement. The last two may be corrected by replacing the valve inlet screen and by properly installing the power element bulb.

Attachment of the expansion valve bulb to the evaporator outlet line is very critical. The bulb must be attached tightly to the line and must make good contact with the line along the entire length of the bulb. A loose bulb will result in high low side pressures and poor cooling.

Indications of expansion valve trouble are provided by performance tests; consult diagnostic charts.

#### 1. VALVE STUCK OPEN

- a. Noisy Compressor
- b. No Cooling - Freeze Up.

#### 2. Valve stuck closed, broken power element or plugged screen

- a. Very Low Suction Pressure.
- b. No Cooling.

#### 3. POORLY LOCATED POWER ELEMENT BULB

- a. Normal Pressure.
- b. Poor Cooling.

### Diagnosis for Defective Valve

The following procedure must be followed to determine if a malfunction is due to a defective expansion valve.

1. Check to determine if the system will meet the performance test as outlined previously. If the expansion valve is defective, the low pressure readings (evaporator pressure) will be above specifications.
2. The loss of system performance is not as evident when the compressor head pressure is below 1 379 kPa (200 psi). Therefore, it may be necessary to increase the system head pressure by partially blocking the condenser. Disconnect the blower lead wire and repeat the "performance check" to determine if the evaporator pressure can be obtained.
3. The system will also indicate a low refrigerant charge by bubbles occurring in the sight glass (Motor Home Chassis Systems).

### EVAPORATOR

When the evaporator is defective, the trouble will show up as an inadequate supply of cool air. A partially plugged core due to dirt, a cracked case, or a leaking seal will generally be the cause.

### REFRIGERANT LINE RESTRICTIONS

Restrictions in the refrigerant lines will be indicated as follows:

1. Suction Line - A restricted suction line will cause low suction pressure at the compressor, low discharge pressure and little or no cooling.
2. Discharge Line - A restriction in the discharge line generally will cause the pressure relief valve to open.
3. Liquid Line - A liquid line restriction will be evidenced by low discharge and suction pressure, and insufficient cooling.

### Sight Glass Diagnosis (Motor Home Chassis Units)

At temperatures higher than 70°F (21°C), the sight glass may indicate whether the refrigerant charge is sufficient. A shortage of liquid refrigerant is indicated

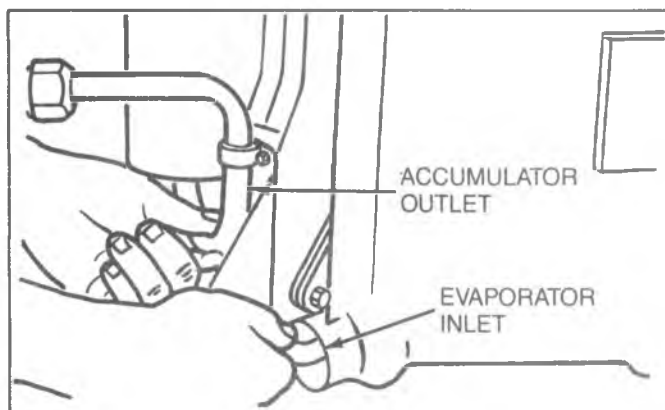

Fig. 1B-25--Checking Evaporator Inlet and Accumulator Outlet Temperatures

after above five minutes of compressor operation by the appearance of slow-moving bubbles (vapor) or a broken column of refrigerant under the glass. Continuous bubbles may appear in a properly charged system on a cool day. This is a normal situation. If the sight glass is generally clear and performance is satisfactory, occasional bubbles do not indicate refrigerant shortage.

If the sight glass consistently shows foaming or a broken liquid column, it should be observed after partially blocking the air to the condenser. If under this condition the sight glass clears and the performance is otherwise satisfactory, the charge shall be considered adequate.

In all instances where the indications of refrigerant shortage continues, additional refrigerant should be added in 120 ml (1/4 lb.) increments until the sight glass is clear. An additional charge of 240 ml (1/2 lb.) should be added as a reserve after the glass clears. In no case should the system be overcharged.

## COMPRESSOR

### C-K SERIES

#### Removal (Fig. 1B-33)

1. Discharge the system.
2. Remove connector attaching bolt and connector. Cap or plug open connections at once.
3. Disconnect electrical lead to clutch actuating coil.
4. Loosen brace and pivot bolts and detach belt.
5. Remove the nuts and bolts attaching the compressor brackets to the mounting bracket. Remove the compressor.
6. Before beginning any compressor disassembly, drain and measure oil in the compressor. Check for evidence of contamination to determine if remainder of system requires servicing. Compressor servicing information is located in the Unit Repair Manual.

#### Installation

1. If oil previously drained from the compressor upon removal shows no evidence of contamination, replace a like amount of fresh refrigeration oil into the compressor before reinstallation. If it was necessary to

service the entire system because of excessive contamination in the oil removed, install a full charge of fresh refrigeration oil into the compressor.

2. Position compressor on the mounting bracket and install all nuts, bolts and lock washers.
3. Install the connector assembly to the compressor rear head, using new "O" rings coated with clean refrigeration oil.
4. Connect the electrical lead to the coil and install and adjust compressor belt.
5. Evacuate, charge and check the system.

## G and Motor Home Chassis Models

#### Removal (Fig. 1B-26)

1. Disconnect battery ground cable.
2. Disconnect compressor clutch connector.
3. Purge the system of refrigerant.
4. Release the belt tension at the idler pulley and remove the belt from the compressor pulley. On some vehicles it may be necessary to remove the crankshaft pulley in order to remove the belt.
5. **G Series**--Remove the two bolts and two clamps that hold the engine cover and remove the cover.
6. Remove the air cleaner to aid access to the compressor.
7. Remove fitting and muffler assembly and cap or plug all open connections.
8. Remove the nuts and bolts attaching the compressor to the bracket.
9. Remove the engine oil tube support bracket bolt and nut from the compressor, and the compressor clutch ground lead.

Before beginning any compressor disassembly, drain and measure oil in the compressor. Check for evidence of contamination to determine if remainder of system requires servicing. Compressor Servicing information is located in the Unit Repair Manual.

#### Installation

1. If the oil drained from the compressor showed no evidence of contamination replace the same amount of fresh refrigeration oil into the compressor before reinstallation. If it is necessary to service the entire system because of excessive contamination in the oil removed, install a full charge of fresh refrigeration oil in the compressor. (Refer to Checking Compressor Oil Charge in the diagnosis section of this service manual.)
2. Position compressor on the mounting bracket and install the nuts, bolts, lock washers, and ground wire.
3. Install the connector assembly to the compressor rear head, using new "O" ring coated with clean refrigeration oil.
4. Connect the electrical lead to the coil and install and adjust compressor belt, using idler pulley. Refer to "Compressor Belt Tension Adjustment."
5. Evacuate, charge and check the system.
6. Replace air cleaner. On G series, replace the engine cover.
7. Connect the battery ground cable.



305-350 V-8 C-K MODELS

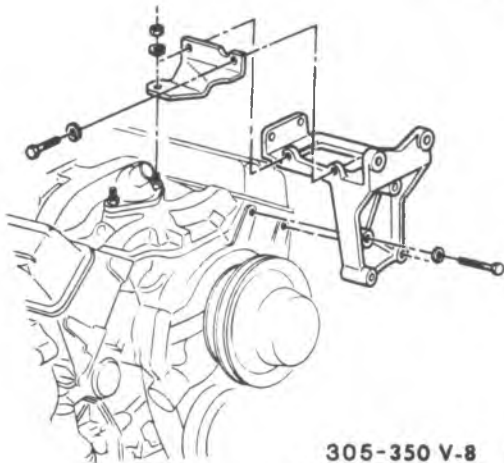
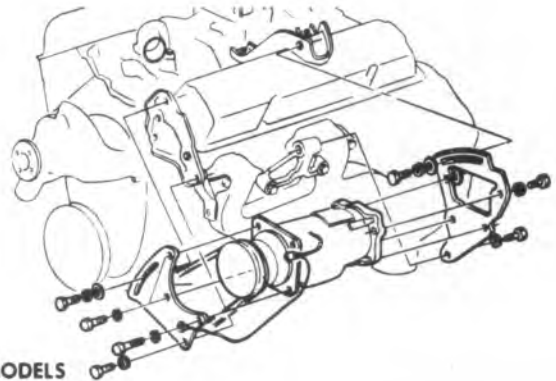

305-350 V-8 G MODELS AND MOTOR HOME CHASSIS

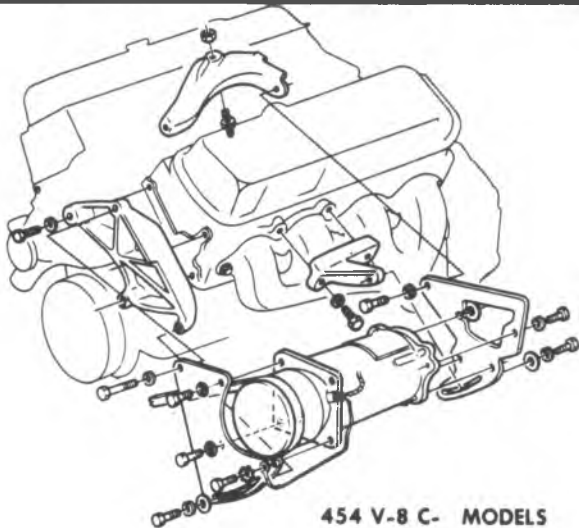
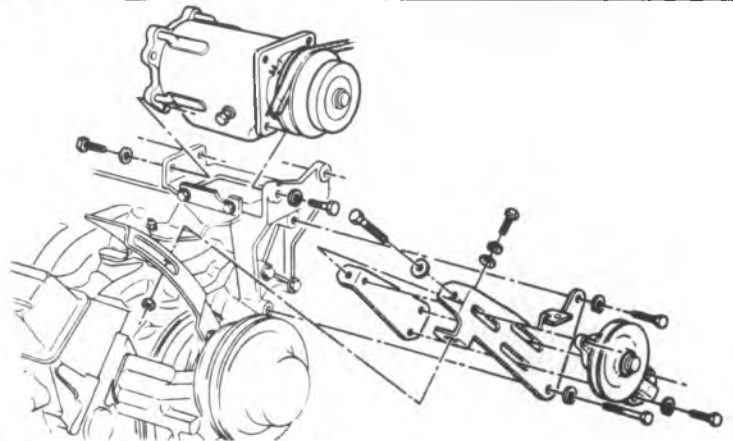

454 V-8 C- MODELS

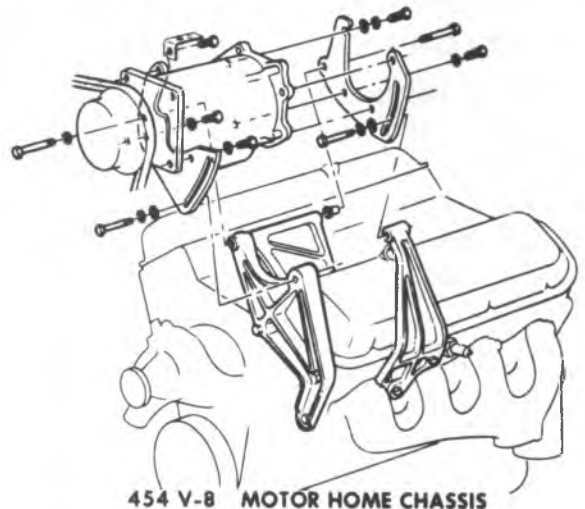

454 V-8 MOTOR HOME CHASSIS

Fig. 1B-26--Compressor Mounting

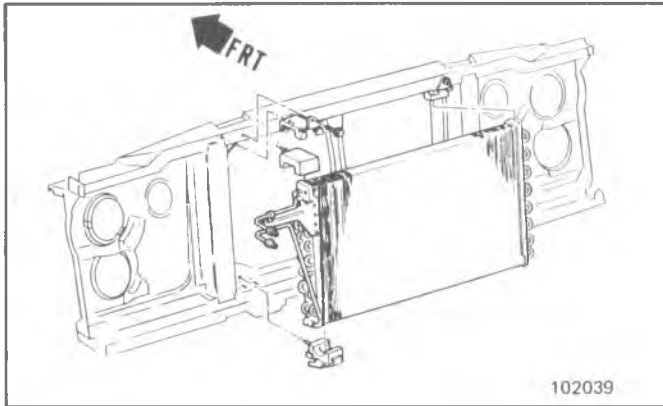

Fig. 1B-27--Condenser Installation (C-K Series)

### Compressor Belt Tension Adjustment

Adjust the compressor belt to the specifications shown in the Engine section of the Service Manual.

On some G and Motor Home Chassis units it may be necessary to increase idler pulley slack adjustment. This may be accomplished by (1) Remove and discard the idler adjustment bolt. (2) Remove the idler backing plate and elongate all 3 adjusting slots 1/2 in. inboard or outboard as required. (3) Reinstall the idler assembly and adjust belt tension using a lever (screwdriver, etc.) to move the pulley outboard until proper belt tension is reached. If the belt is being replaced it may be necessary to remove and replace the throttle cable during the belt replacement. If so check throttle cable adjustment upon completion. It may also be necessary to remove the crankshaft pulley to install a new compressor belt.

## C60 SYSTEM--C-K SERIES

### CONDENSER - C-K SERIES (FIG. 1B-27)

#### Replacement (Fig. 1B-27)

1. Disconnect battery ground cable.
2. Discharge system.
3. Remove the grille assembly.
4. Remove the radiator grille center support.
5. Remove the left grille support to upper fender support (2) screws.
6. Disconnect the condenser inlet and outlet lines and the outlet tube line at the right end of the condenser. Cap or plug all open connections at once.
7. Remove the condenser to radiator support screws.
8. Bend the left grille support outboard to gain clearance for condenser removal.
9. Remove the condenser assembly by pulling it forward and then lowering it from the vehicle.
10. To install a new condenser, reverse Steps 1 thru 9 above. Add one fluid ounce of clean refrigeration oil to a new condenser.

Use new "O" rings, coated with clean refrigeration oil, when connecting all refrigerant lines.

11. Evacuate, charge and check the system.

## ACCUMULATOR - ALL

### Replacement

1. Disconnect the battery ground cable and the compressor clutch connector.
2. Discharge system.
3. Disconnect the accumulator inlet and outlet lines and cap or plug the open connections at once.
4. Remove the accumulator bracket screws and remove the accumulator from the vehicle.
5. Drain any excess refrigerant oil from the accumulator into a clean container. Measure and discard the oil.
6. If a new accumulator is being installed, add one ounce of clean refrigeration oil to the new accumulator **PLUS** an amount equal to that drained in Step 5 above.
7. To install the new accumulator, reverse Steps 1 thru 4 above. Connect all lines using new "O" rings, coated with clean refrigeration oil.  
Do not uncap the new unit until ready to fasten the inlet and outlet line to the unit.
8. Evacuate charge and check the system.

## BLOWER ASSEMBLY - C-K SERIES

### Replacement

1. Disconnect the battery ground cable.
2. Disconnect the blower motor lead and ground wires.
3. Disconnect the blower motor cooling tube.
4. Remove the blower to case attaching screws and remove the blower assembly. Pry the blower flange away from the case carefully if the sealer acts as an adhesive.
5. Remove the nut attaching the blower wheel to the motor shaft and separate the assemblies.
6. To install, reverse Steps 1 thru 5 above; replace sealer as necessary.

## EVAPORATOR CORE

### Replacement (Fig. 1B-28)

1. Disconnect the battery ground cable.
2. Discharge system.
3. Remove the nuts from the selector duct studs projecting through the dash panel.

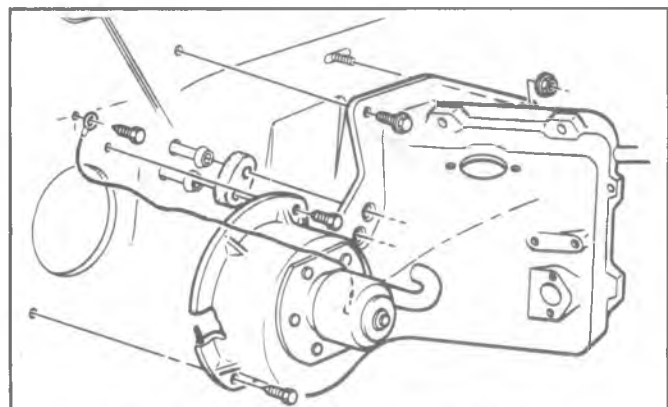

Fig. 1B-28--Blower-Evaporator (C-K Series)

4. Remove the cover to dash and cover to case screws and remove the evaporator case cover.
5. Disconnect the evaporator core inlet and outlet lines and cap or plug all open connectins at once.
6. Remove the expansion tube as outlined under expansion tube replacement.
7. Remove the evaporator core assembly.
8. To install, reverse Steps 1 thru 7 above. Add 90 ml (3 oz.) of clean refrigeration oil to a new evaporator core. Use new "O" rings, coated with clean regrigeration oil, when connecting refrigerant lines. Be sure cover to case and dash panel sealer is intact before reinstalling cover.
9. Evacuate, charge and check the system.

### EXPANSION TUBE-C-K, & G

The expansion tube is located in the evaporator core inlet line.

#### Replacement

1. Discharge system.
2. Disconnect the condenser to evaporator line at the evaporator inlet. Cap the open line at once.
3. Using needle-nose pliers, remove the expansion tube from the evaporator core inlet line.
4. Remove the expansion tube "O" ring from the core inlet line.
5. To install, reverse Steps 1 thru 4 above. Install the expansion tube using a new "O" ring coated with clean regrigeration oil, by inserting the short screen end of the tube into the evaporator inlet line.
6. Evacuate, charge and check the system.

### SELECTOR DUCT AND HEATER CORE ASSEMBLY-C-K

#### Replacement (Fig. 1B-30)

1. Disconnect the battery ground cable.
2. Drain the radiator and remove the heater hoses from the core tubes. Plug the core tubes to prevent coolant spillage during removal.
3. Remove the glove box and door as an assembly.
4. Remove the center duct to selector duct and instrument panel screws and remove the center lower and center upper ducts.
5. Disconnect the bowden cable at the temperature door.
6. Remove the nuts from the three selector duct studs projecting through the dash panel.
7. Remove the selector duct to dash panel screw (inside vehicle).
8. Pull the selector duct assembly rearward until the core tubes clear the dash panel. Lower the selector assembly far enough to gain access to all vacuum and electrical harnesses.
9. Disconnect the vacuum and electrical harness and remove the selector duct assembly.
10. Remove the core mounting strap screws and remove the core.
11. To install, reverse Steps 1 thru 10 above.

12. Refill coolant system and connect the battery ground strap. Check temperature door cable adjustment.

### KICK PAD VALVE - C-K SERIES

#### Replacement (Fig. 1B-31)

1. Disconnect the vacuum hose at the actuator.
2. Unhook the valve return spring at the actuator end.
3. Remove the actuator bracket mounting screws.
4. Remove the cam to actuator arm screw and separate the actuator and bracket from the cam.
5. Remove the actuator to bracket nuts and separate the actuator and bracket.
6. To install reverse Steps 1 thru 5 above.

### PLENUM VALVE - C-K SERIES

#### Replacement (Fig. 1B-31)

1. Raise the hood.
2. Remove the cowl plastic grille.
3. Remove the three cowl to valve assembly screws and remove the valve assembly from the vehicle.
4. Remove the actuator arm pushnut.
5. Remove the actuator to valve nuts and separate the valve and actuator.
6. To install, reverse Steps 1 thru 5 above.

### CONTROL ASSEMBLY - C-K SERIES

#### Removal (Fig. 1B-32)

1. Disconnect the battery ground cable.
2. Remove the radio as outlined in Section 8 of this manual.
3. Remove the instrument panel bezel.
4. Remove the control to instrument panel screws and lower the control far enough to gain access to the control assembly. Be careful not to kink the bowden cable.
5. Disconnect the bowden cable, vacuum harness and electrical harness at the control.
6. Remove the control.
7. If a new unit is being installed, transfer the master blower switches to the new control.
8. To reinstall, reverse Steps 1 thru 6 above. Check control operation.

### TEMPERATURE DOOR CABLE ADJUSTMENT - C-K MODELS

1. Remove glove box and door assembly.
2. Loosen the cable attaching screw at the selector duct assembly.
3. Make sure the cable is installed in the bracket on the selector duct assembly.
4. Place temperature lever in full COLD position and hold while tightening cable attaching screw.

### MASTER SWITCH AND/OR BLOWER SWITCH - C-K SERIES

The master switch is located on rear of the control assembly.

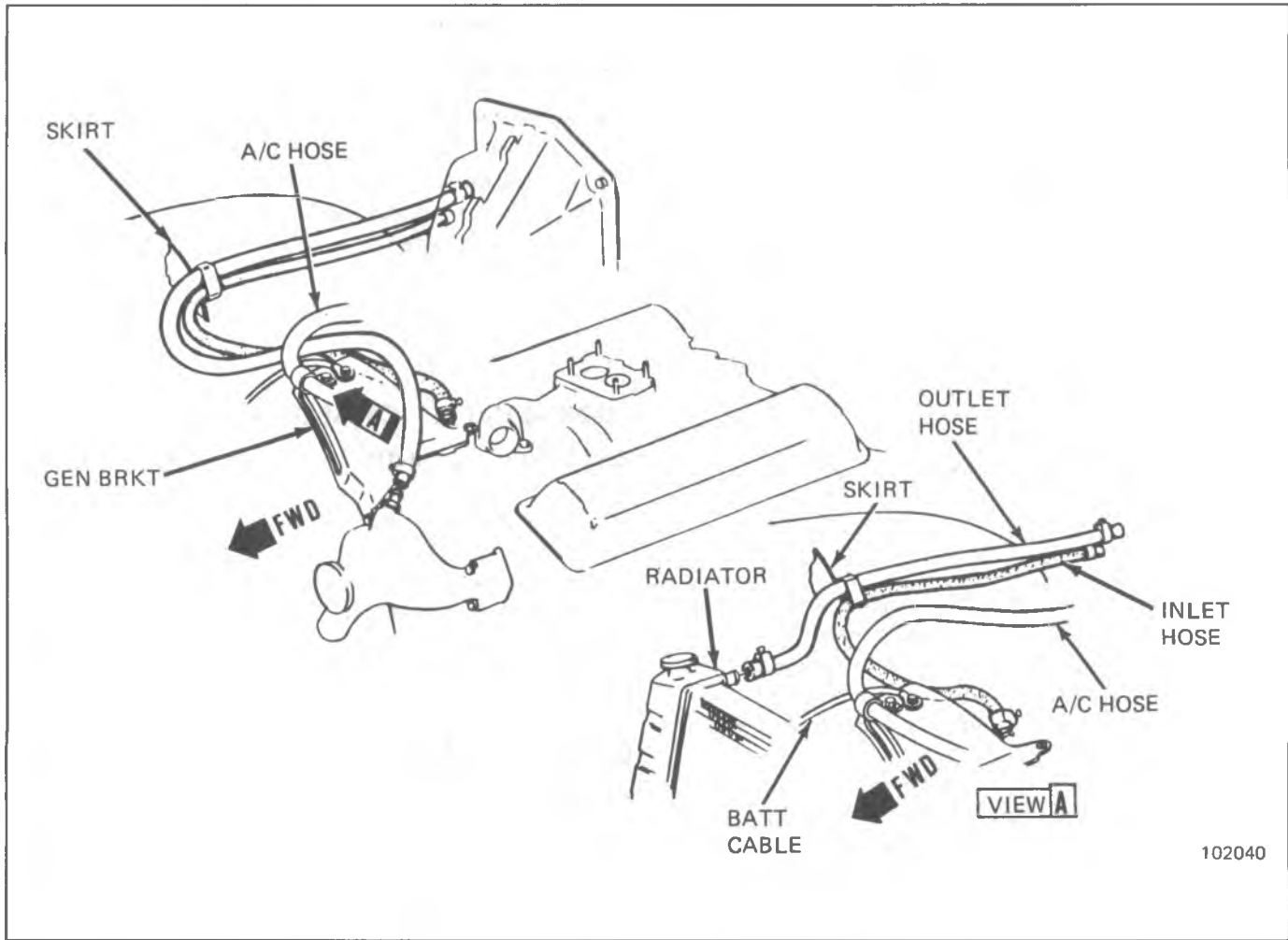

102040

Fig. 1B-29--Heater Hose Routings (C-K Series)



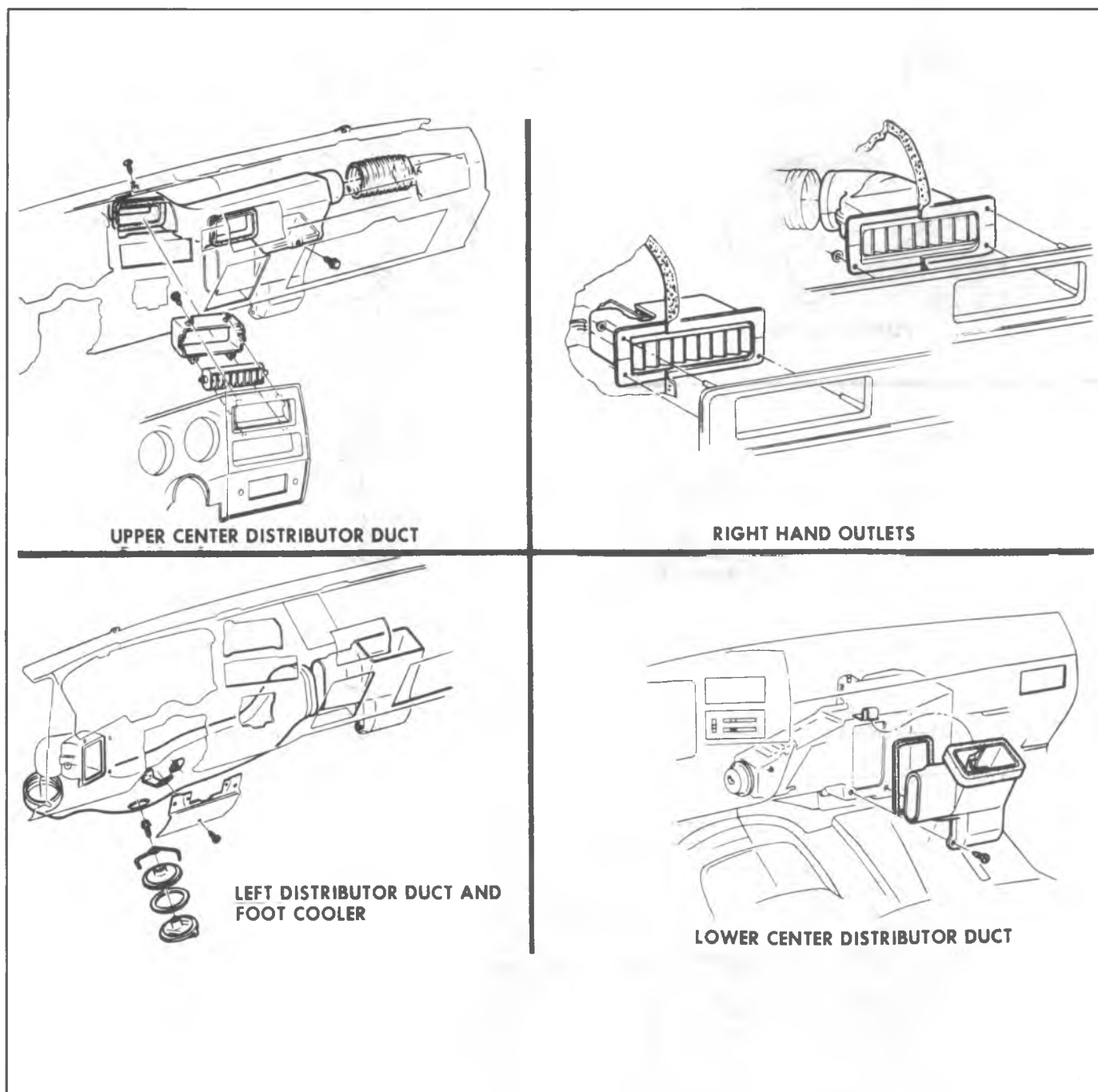

Fig. 1B-30--Air Selector and Ducts (C-K Series)

**Replacement**

1. Disconnect the battery ground cable.
2. Remove the instrument panel bezel.
3. Remove the control to instrument panel screws and allow control to rest on top of the radio.
4. Remove the switch to control screws, disconnect the electrical harness (and vacuum harness on master switch) at the switch and remove the switch assembly.
5. To install a new switch, reverse Steps 1 thru 4 above.

**VACUUM TANK**

The vacuum tank is mounted to the engine side of the dash panel above the blower assembly (Fig. 1B-33).

**Replacement**

1. Disconnect the vacuum lines at the tank.
2. Remove the tank to dash panel screws and remove the tank.
3. To install, reverse Steps 1 and 2 above.

**BLOWER MOTOR RESISTOR**

The blower motor resistor is located in the blower side of the blower-evaporator case (Fig. 1B-35).

**Replacement**

1. Disconnect the wiring harness at the resistor.
2. Remove the resistor to case attaching screws and remove the resistor.
3. Place the new resistor in position and install the

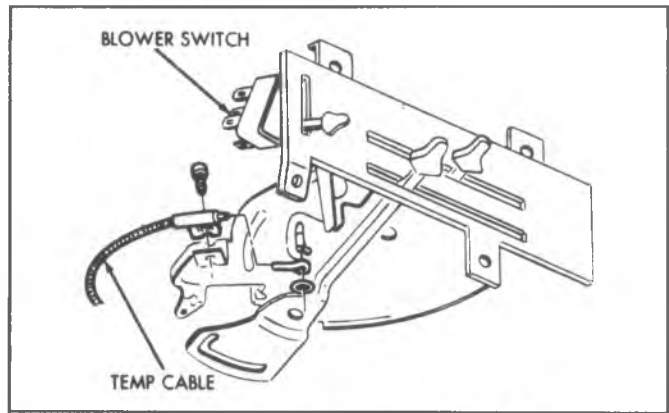
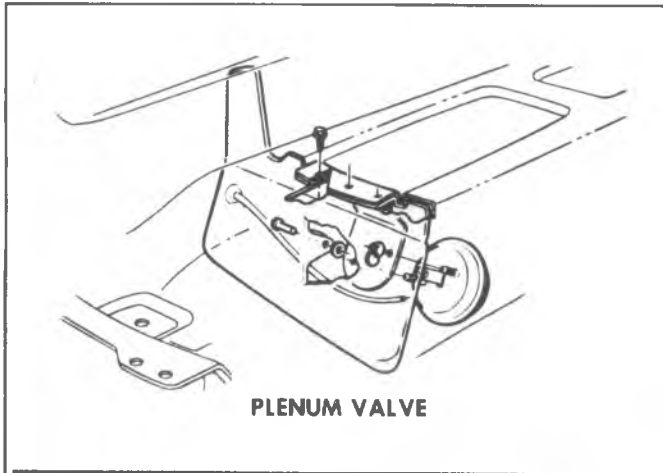

Fig. 1B-32--Control Assembly C-K, C60 System

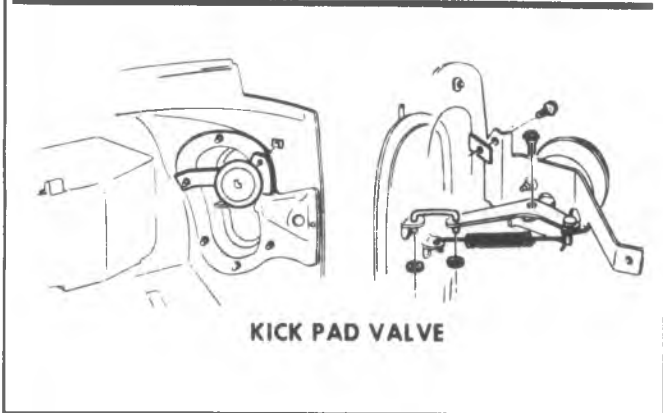

Fig. 1B-31--Air Inlet Valves (C-K Models)

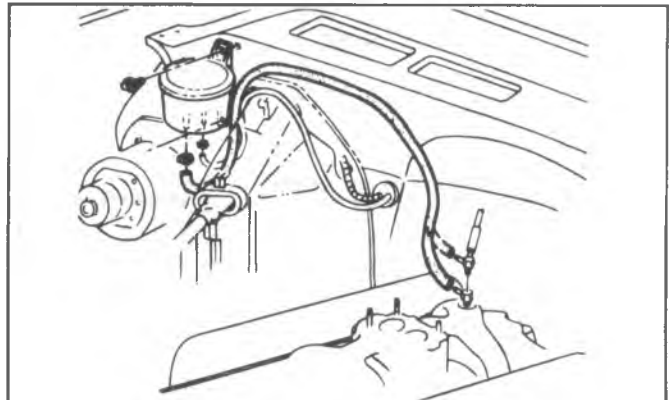

Fig. 1B-33--Vacuum Tank C-K Models

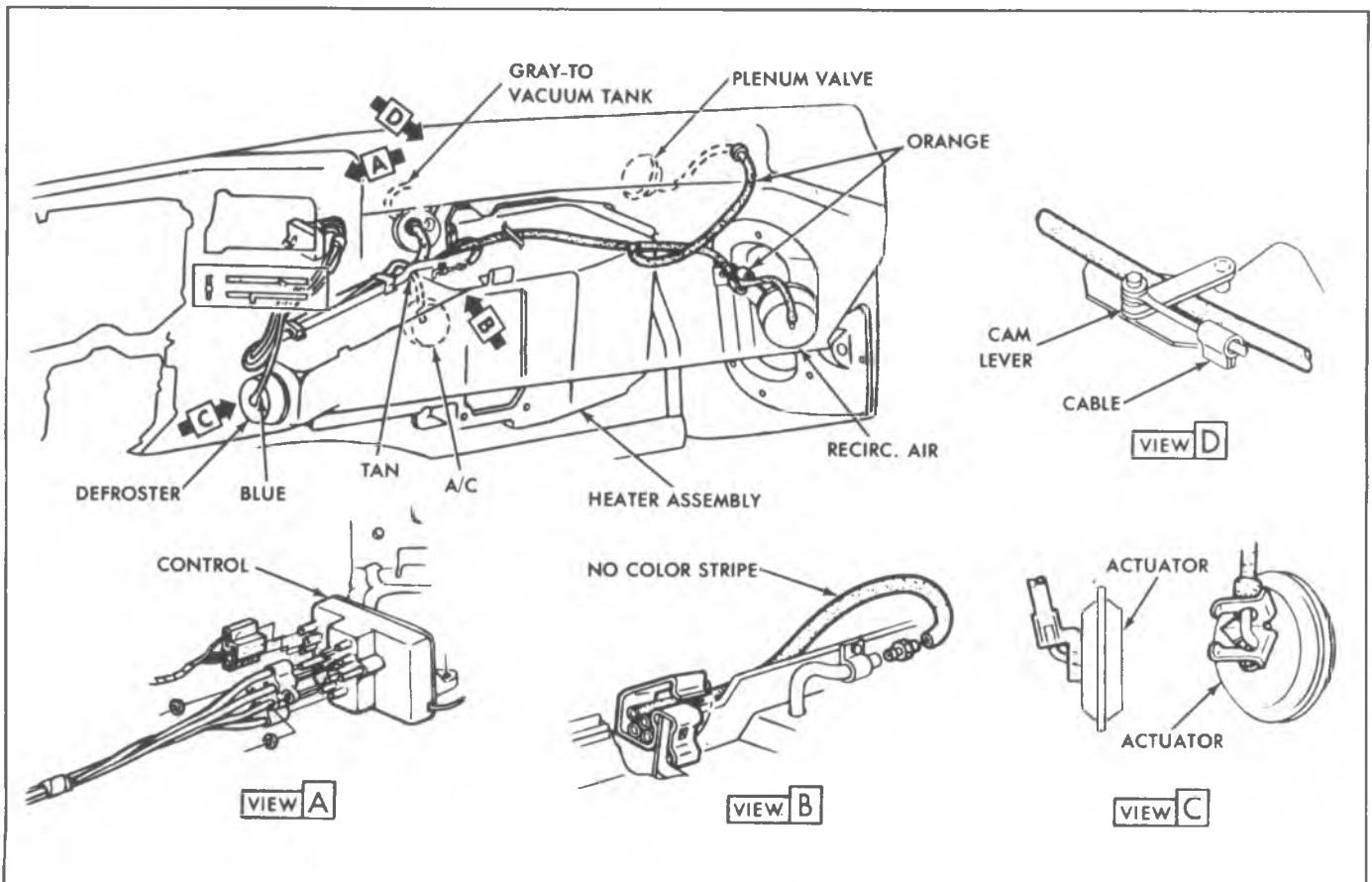

Fig. 1B-34--Vacuum Line Routing - C-K Models

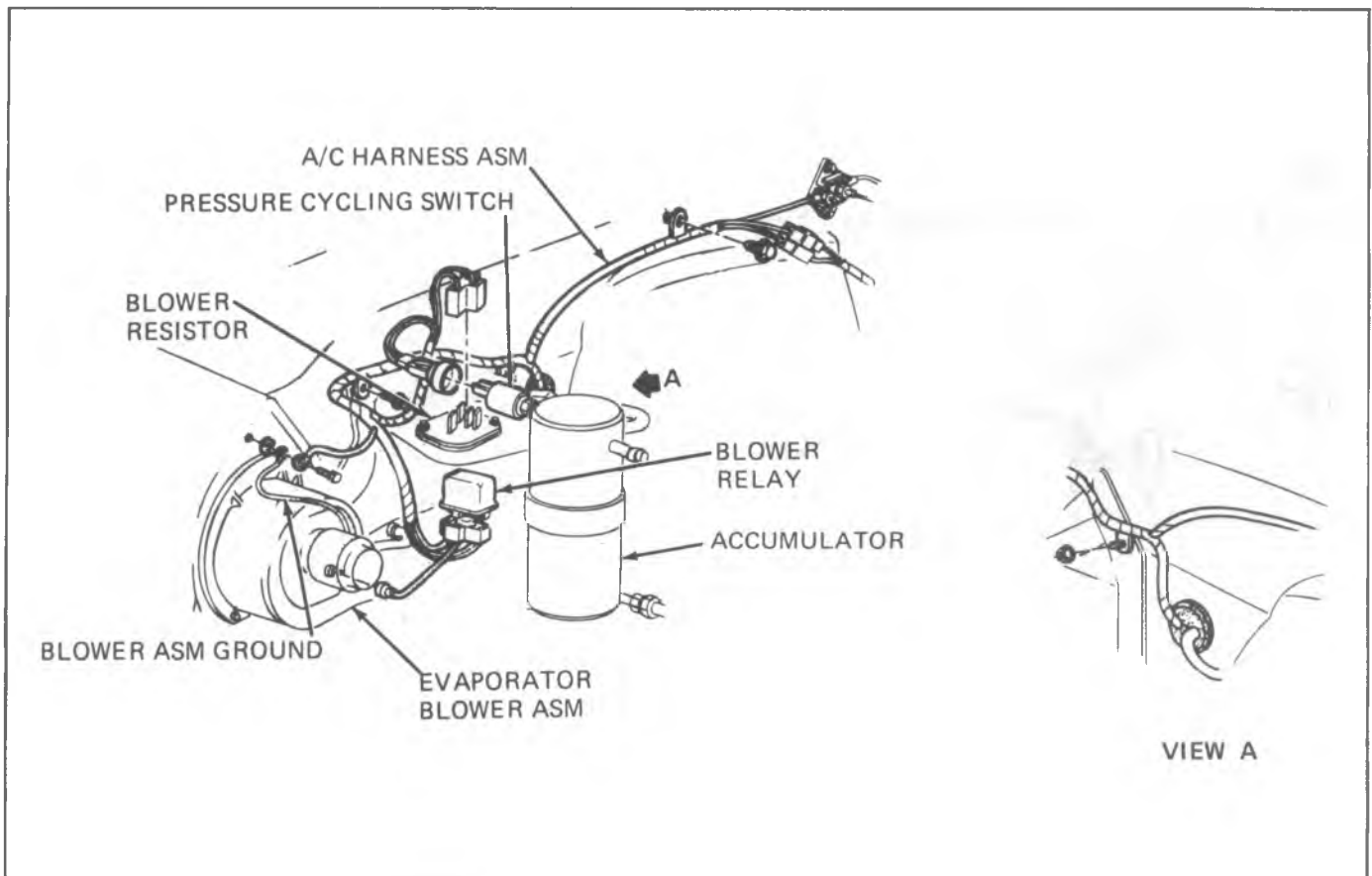

Fig. 1B-35--Engine Compartment Wiring Harness (C-K Models)

attaching screws.

4. Connect the resistor wiring harness.

**BLOWER MOTOR RELAY - ALL**

The blower motor relay is located on the blower side of the blower-evaporator case (Fig. 35).

**Replacement**

1. Disconnect the wiring harness at the relay.
2. Remove the relay to case attaching screws and remove the relay.
3. Place the new relay in position and drive the mounting screws.
4. Connect the relay wiring harness.

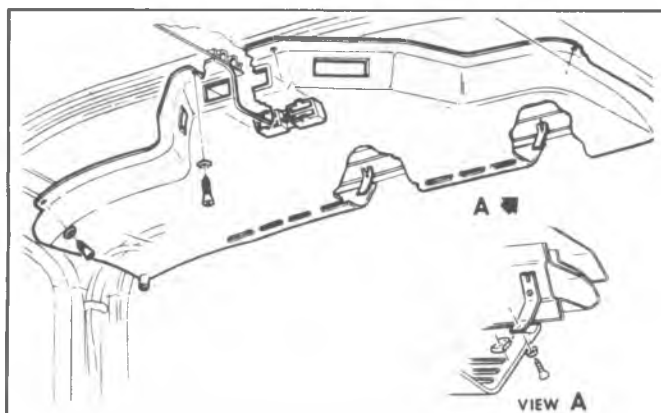

Fig. 1B-36--Rear Duct C-K & G Overhead System

**FUSE**

A 25 amp fuse, located in the junction block protects the entire air conditioning system except for the blower circuit, the fuse for the blower circuit is located in the electrical wiring between the junction block and the blower relay.

**OVERHEAD SYSTEM--C-K MODELS**

The Overhead System is used in conjunction with the C60 System. Since replacement of C60 System components has been covered previously, only those components peculiar to the Overhead System will be covered in this section.

**REAR DUCT**

This duct covers the blower-evaporator assembly, at the rear of the vehicle, and incorporates four adjustable air outlets (Fig. 1B-36).

**Replacement**

1. Disconnect the battery ground cable.
2. Disconnect the drain tube from the rear duct.
3. Remove the screws securing the duct to the roof panel and rear header brackets.
4. Remove the duct.
5. To install, reverse Steps 1 thru 4 above.

**BLOWER MOTOR RESISTOR**

The blower motor resistor is located on the cover side of the C60 System blower-evaporator as shown in Fig. 1B-37.

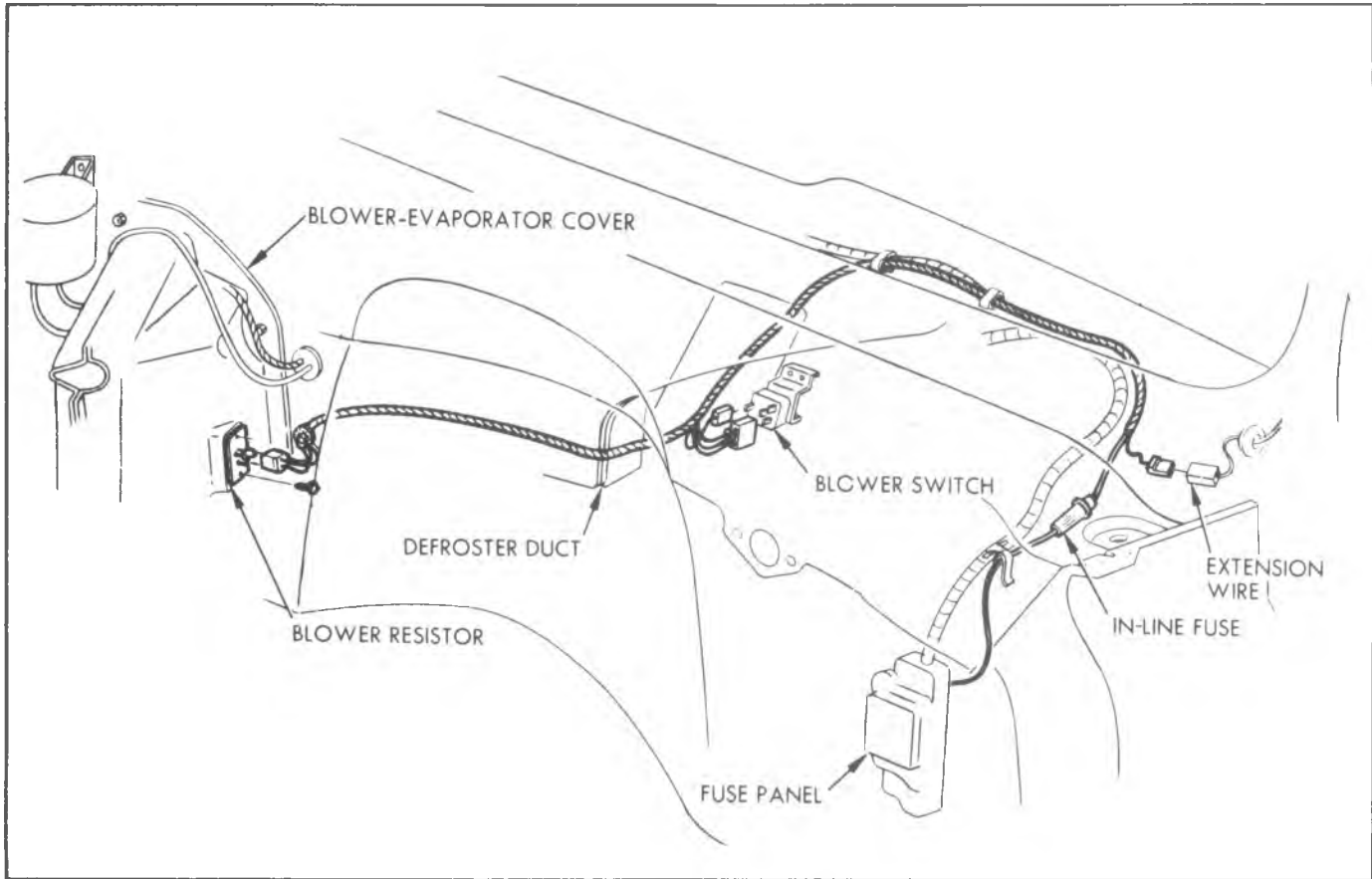

Fig. 1B-37--Overhead System Front Wiring (C-K Models)

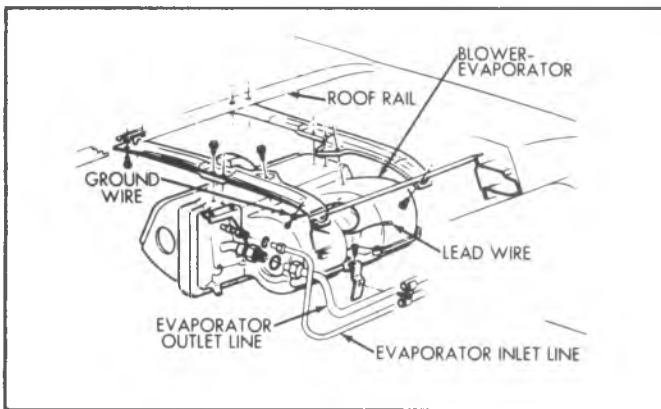

Fig. 1B-38--Blower-Evaporator (C-K Overhead System)

**Replacement**

1. Disconnect battery ground cable.
2. Disconnect the electrical harness at the resistor.
3. Remove the resistor attaching screws and remove the resistor.
4. To install a new resistor, reverse Steps 1 thru 3 above.

**BLOWER MOTOR ASSEMBLY**

**Removal (Fig. 1B-38)**

1. Disconnect the battery ground cable.
2. Remove the rear duct as outlined previously.
3. Disconnect the blower motor ground strap.
4. Disconnect the blower motor lead wire.

5. Remove the lower to upper blower-evaporator case screws and lower the lower case and motor assembly.

**NOTICE:** Before removing the case screws, support the lower case to prevent damage to the case or motor assemblies.

6. Remove the motor retaining strap and remove the motor and wheels. Remove the wheels from the motor shaft.

**Installation**

1. Place the blower wheels onto the motor shaft making sure the wheel tension springs are installed on hub of wheels.

Be sure that the blower wheels are installed as shown in Fig. 1B-39.

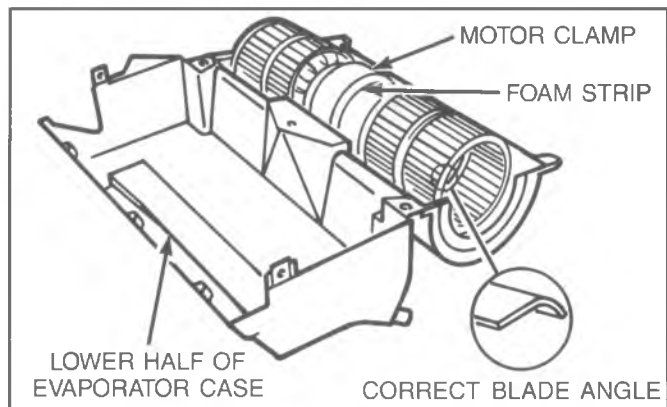

Fig. 1B-39--Blower Motor (C-K Overhead System)

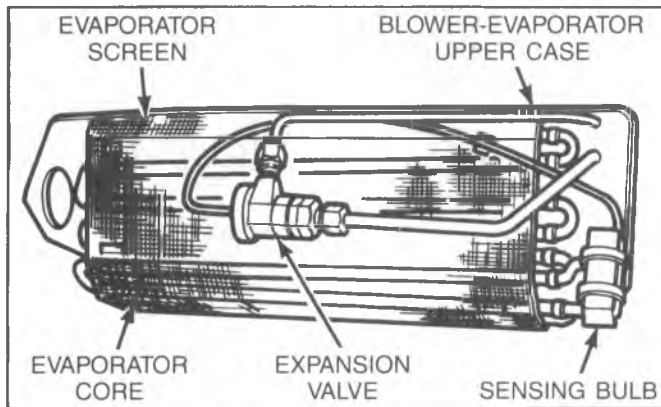

Fig. 1B-40--Expansion Valve C69 System

2. Install the blower motor retaining strap and foam.
3. Place the blower motor and wheel assembly into the lower case. Align the blower wheels so that they do not contact the case.
4. Place the lower case and blower motor assembly in position in the vehicle and install the lower to upper case screws.

**NOTICE:** Rotate the blower wheels to make sure that they do not rub on the case.

5. Install the center ground wire and connect the blower lead wire.
6. Install the rear duct assembly as described previously.
7. Connect the battery ground cable.

## EXPANSION VALVE

This system incorporates an expansion valve which does not utilize an external equalizer line (Fig. 1B-40).

### Removal

1. Disconnect battery ground cable.
2. Purge the system of refrigerant.
3. Remove the rear duct as outlined previously.
4. Disconnect the blower motor lead and ground wires.
5. Remove the lower to upper blower-evaporator case screws and lower the lower case and motor assembly.

**NOTICE:** Before removing the case screws, support the lower case and motor assemblies to prevent damage to the case or motor assemblies.

6. Remove the expansion valve sensing bulb clamps.
7. Disconnect the valve inlet and outlet lines and remove the expansion valve assembly. Cap or plug the open connections at once.

### Installation

1. Remove caps or plugs from system connections and install the new valve assembly using new "O" rings coated with clean refrigeration oil.
2. Install the sensing bulb, making sure that the bulb makes good contact with the core outlet line.
3. Install the lower case and blower motor assemblies. Connect the blower motor lead and ground wires.
4. Install the rear duct as outlined previously.
5. Connect the battery ground cable.
6. Evacuate, charge and check the system.

## EVAPORATOR CORE (Fig. 1B-40)

### Removal

1. Disconnect the battery ground cable.
2. Purge the system of refrigerant.
3. Remove the rear duct as outlined previously.
4. Disconnect the blower motor lead and ground wire connections.
5. Disconnect the refrigerant lines at the rear of the blower-evaporator assembly. Cap or plug the open connections at once.
6. Remove the blower-evaporator support to roof rail screws, lower the blower-evaporator assembly and place it on a work bench upside down.
7. Remove the lower to upper case screws and remove the lower case assembly. Remove the support to upper case screws and remove the upper case from the evaporator core.
8. Remove the expansion valve inlet and outlet lines and cap or plug the open connections at once. Remove the expansion valve capillary bulb from the evaporator outlet line and remove the valve.
9. Remove the plastic pins holding the screen to the core and remove the screen.

### Installation

1. Install the wire screen to the front of the core and insert the plastic pins.
2. Install the expansion valve inlet and outlet lines using new "O" rings coated with clean refrigeration oil. Install the sensing bulb to the evaporator outlet line as shown in Fig. 1B-44; make sure the bulb has good contact with the line.  
Add 3 oz. clean refrigeration oil when installing a new core.
3. Install the upper case and supports to the core.
4. Install the lower core case and blower assembly.
5. Install the blower-evaporator assembly to the roof and install the support to roof rail screws.
6. Connect the refrigerant lines to the blower-evaporator unit using new "O" rings coated with clean refrigeration oil.
7. Connect the blower lead and ground wires.
8. Install the rear duct as outlined previously.
9. Connect the battery ground cable.



Fig. 1B-41--Blower Switch (C-K Overhead System)

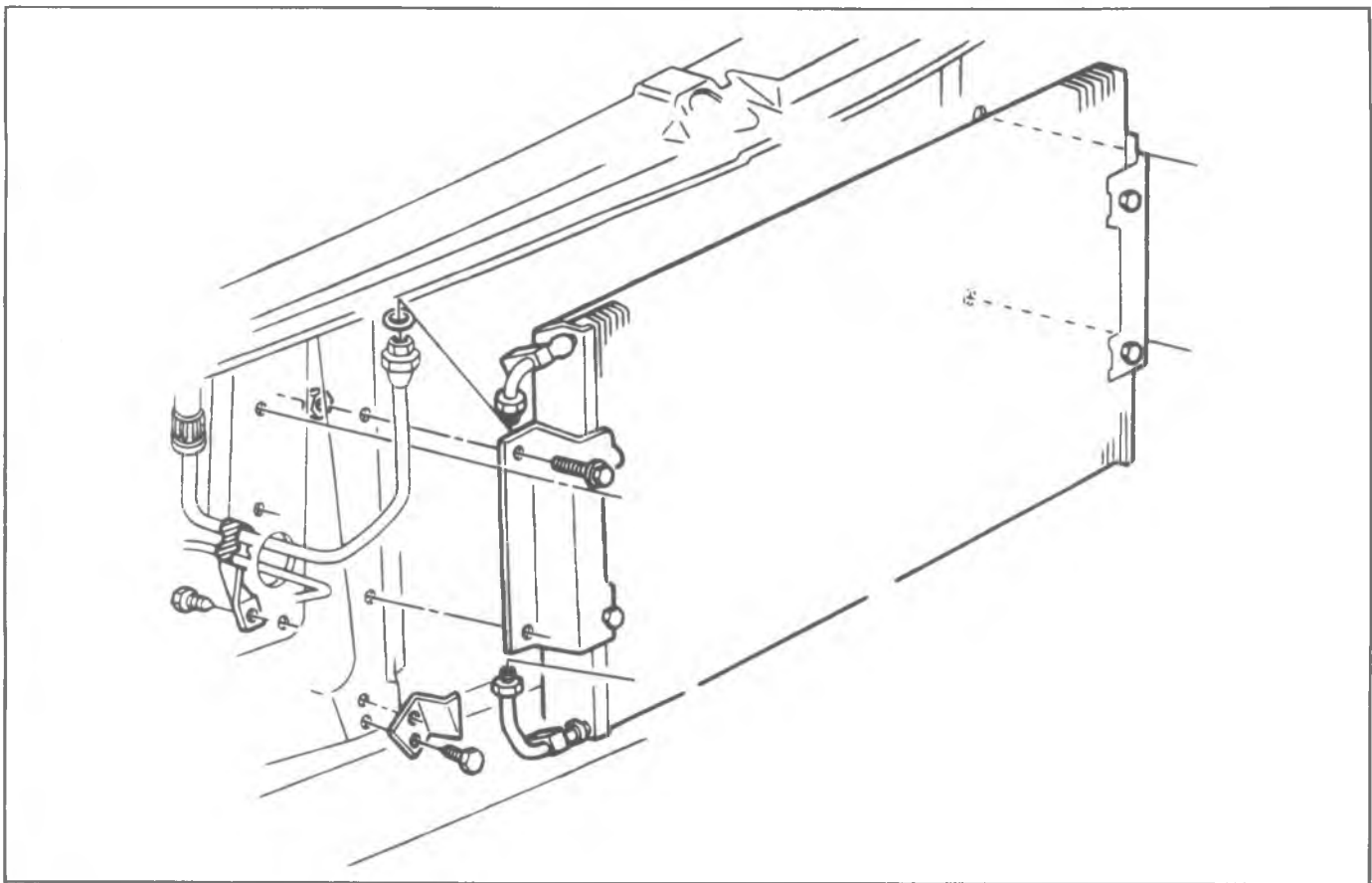

Fig. 1B-42--Condenser-G Series

10. Evacuate, charge and check the system.

### BLOWER MOTOR SWITCH

The three-speed (LO-MED-HI) blower motor switch is located in the instrument panel, just to the left of the ash tray (Fig. 1B-41).

#### Replacement

1. Disconnect the battery ground cable.
2. Remove the switch retaining screws.
3. Disconnect the wiring harness at the switch and remove the switch.
4. To install, reverse Steps 1 thru 3 above.

### FUSE

The Four Season portion of this system is protected by a 25 amp fuse in the junction block.

The rear blower high speed circuit is protected by a 20 amp in-line fuse, located between the junction block and the rear blower motor switch.

## C60 SYSTEM--G SERIES

### CONDENSER - G Series

#### Replacement (Fig. 1B-42)

1. Disconnect battery ground cable.
2. Purge the system of refrigerant.
3. Remove grille, hood lock, and center hood lock support as an assembly.

4. Disconnect condenser inlet and outlet lines at condenser.
5. Remove screws attaching left side condenser bracket to radiator.
6. Remove screws attaching right side condenser bracket to condenser.
7. Remove condenser from vehicle.
8. Remove left hand bracket from condenser.
9. To install new condenser, reverse steps 3 thru 8 above. Add 30 ml (1 oz.) of clean refrigeration oil to a new condenser.
10. Evacuate charge and test the system.

Refer to Fig. 1B-61 thru 1B-66 for condenser inlet and outlet connections, compressor refrigerant line connections, and general refrigerant line routing and connections.

### HEATER AIR DISTRIBUTOR

#### AND EXTENSION DUCT - G SERIES

#### Replacement (Fig. 1B-43)

1. Disconnect battery ground cable.
2. Remove engine cover.
3. Remove evaporator-blower shield.
4. Remove shield bracket.
5. Remove left floor outlet deflector and bracket.
6. Loosen steering column to instrument panel reinforcement screws. Remove one screw. Torque both screws on installation.
7. Disconnect speedometer cable at meter.

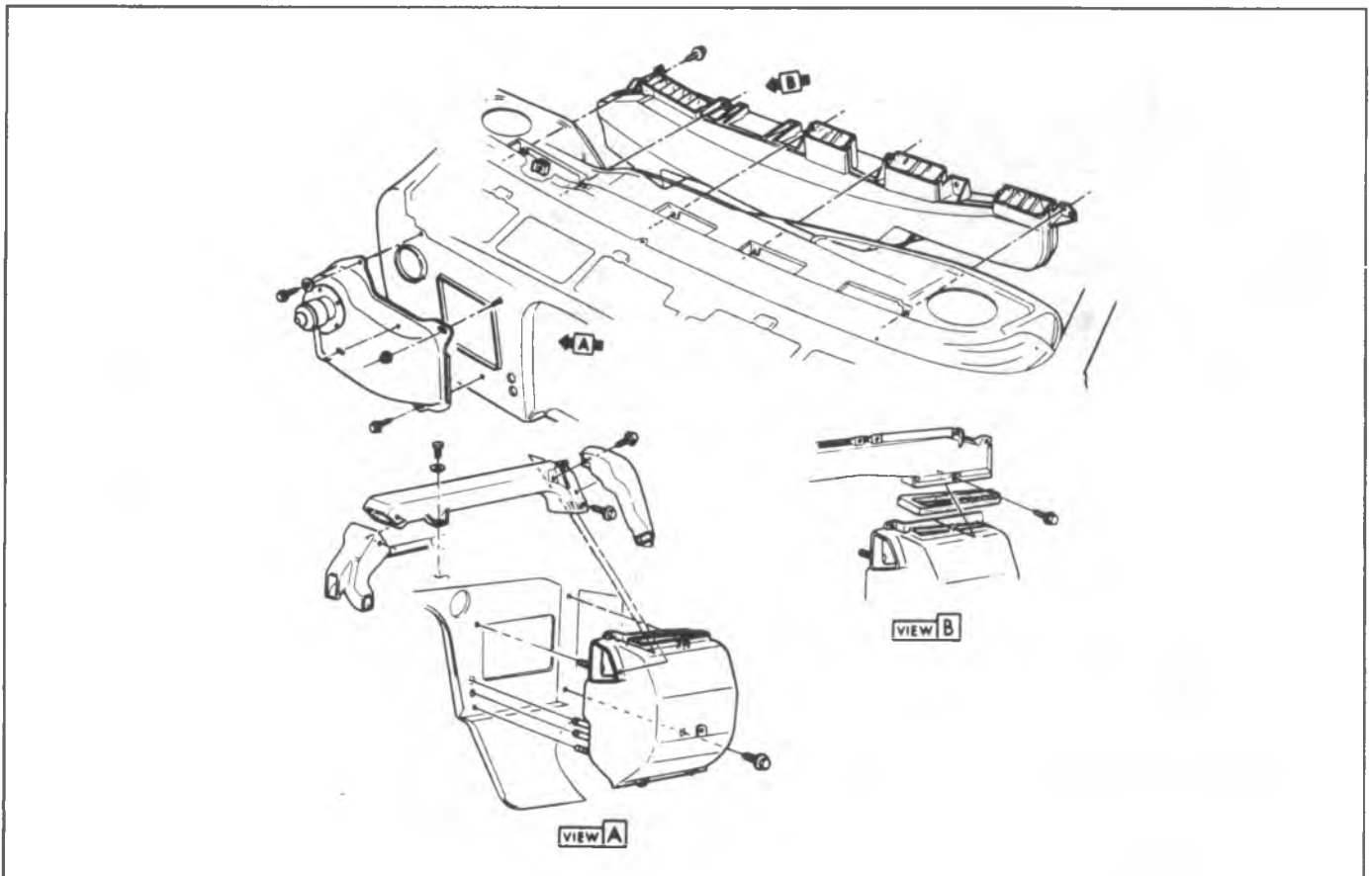

Fig. 1B-43--Heater Distributor Duct-G Series

**HEATER CORE - G SERIES**

**Replacement**

1. Disconnect battery ground cable.
2. Remove engine cover as outlined in Section 6A of this manual.
3. Remove steering column to instrument panel attaching bolts and lower column.
4. Remove upper and lower instrument panel attaching

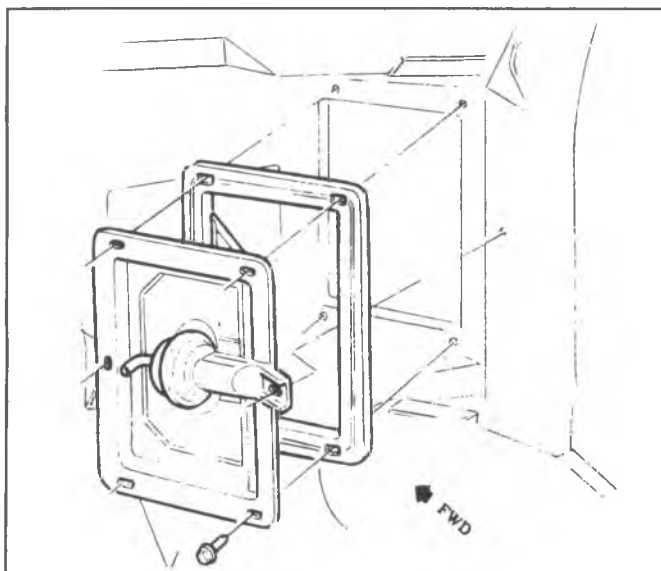

Fig. 1B-44--Recirculating Air Door Vacuum Actuator

screws and radio support bracket attaching screw.

5. Raise and support right side of instrument panel.
6. Remove right lower instrument panel support bracket.
7. Remove recirculating air door vacuum actuator. Refer to Fig. 1B-44.
8. Disconnect temperature cable and vacuum hoses at distributor case.
9. Remove heater distributor duct, refer to Fig. 1B-45.
10. Remove 2 defroster duct to dash panel attaching screws (below windshield).
11. Working from the engine compartment, disconnect heater hoses and plug to prevent water spillage.
12. Remove three (3) nuts from bolts attaching heater core case to dash panel and one (1) screw at lower right corner (inside).
13. Remove distributor assembly from vehicle.
14. Remove gasket to expose screws attaching case sections together as shown in Fig. 1B-46.
15. Remove temperature cable support bracket.
16. Remove case attaching screws and separate case.
17. Remove heater core.
18. To install new heater core, reverse Steps 2 thru 17 above.



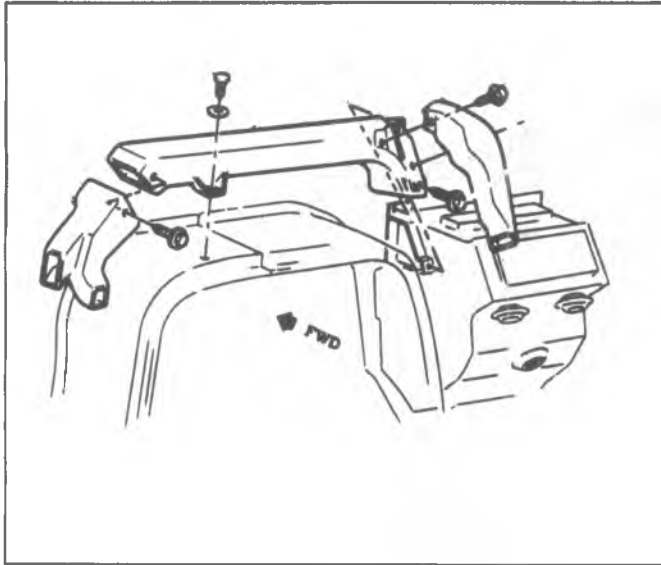

Fig. 1B-45--Heater Distributor Duct

The 6.2 Liter Diesel Engine has extra insulation around the blower motor on vehicles without C60 and around the blower motor and evaporator core with C60 option.

### BLOWER MOTOR INSULATION REMOVAL

1. Remove parking lamp assembly.
2. Remove the radiator overflow tank.
3. See Fig. 1B-46a for location of the screws.
4. Remove insulation through the hood opening.
5. Proceed with normal blower motor removal.
6. To install, reverse the above procedure.

### A/C EVAPORATOR REMOVAL

1. Remove cold air intake.
  2. Disconnect hood latch assembly and cable retainer and place it out of the way.
  3. Remove windshield solvent tank.
  4. Discharge the A/C system.
- NOTICE:** When removing any A/C components, make sure that the component is capped to prevent contamination.
5. Disconnect the low pressure vapor line and move it out of the way.
  6. Remove accumulator.
  7. Disconnect and remove high pressure line inlet to the evaporator and the connecting bracket.
  8. Remove the wiring harnesses going to the blower motor relay and resistors.
  9. Remove the blower motor relay and resistors.
  10. Remove the fan shroud upper half.
  11. Remove the radiator.
  12. Disconnect the heater valve assembly bracket and move it out of the way.
  13. Remove the upper screws of the lower section, see Fig. 1B-46a, and push it down and out of the way.
  14. See Fig. 1B-46a for the location of the insulation mounting screws.

15. Remove insulation through the hood opening.
16. Proceed with the A/C evaporator procedure.
17. Reverse the above procedure for installation.

### BLOWER MOTOR - G SERIES

#### Replacement

1. Disconnect battery ground cable.  
**G Series** - Remove the coolant recovery tank, and power antenna as outlined in Sections 6 and 9.
2. Disconnect the blower motor lead wire.
3. Remove the five blower motor mounting screws and remove the motor and wheel assembly. Pry gently on the blower flange if the sealer acts as an adhesive.
4. Remove the blower wheel to motor shaft nut and separate the wheel and motor assemblies.
5. To install a new motor, reverse Steps 1 thru 4 above.  
 The following steps should be taken to assure proper installation:
  - a. Assemble the blower wheel to the motor with the open end of the wheel away from the blower motor.
  - b. If the motor mounting flange sealer has hardened, or is not intact, remove the old sealer and apply a new bead of sealer to the entire circumference of the mounting flange.
  - c. Check blower operations: blower wheel should rotate freely with no interference.

### EVAPORATOR CORE

#### Replacement (Fig. 1B-54)

1. Disconnect battery ground cable.
2. Purge system of refrigerant.
3. Remove coolant recovery tank and bracket as outlined earlier.
4. Disconnect all electrical connectors from core case assembly.
5. Remove bracket at evaporator case.
6. Remove right hand marker lamp for access.
7. Disconnect accumulator inlet and outlet lines and 2 brackets attaching accumulator to case.
8. Disconnect evaporator inlet line.
9. Remove three (3) nuts and one (1) screw attaching

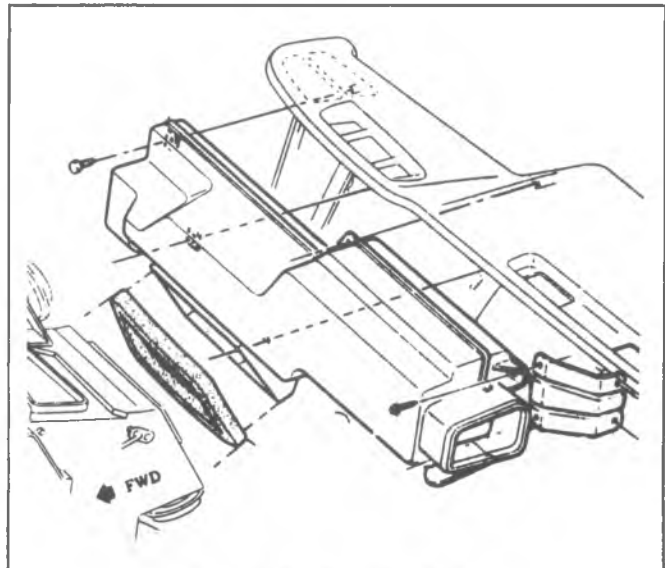

Fig. 1B-46--Distributor Gasket



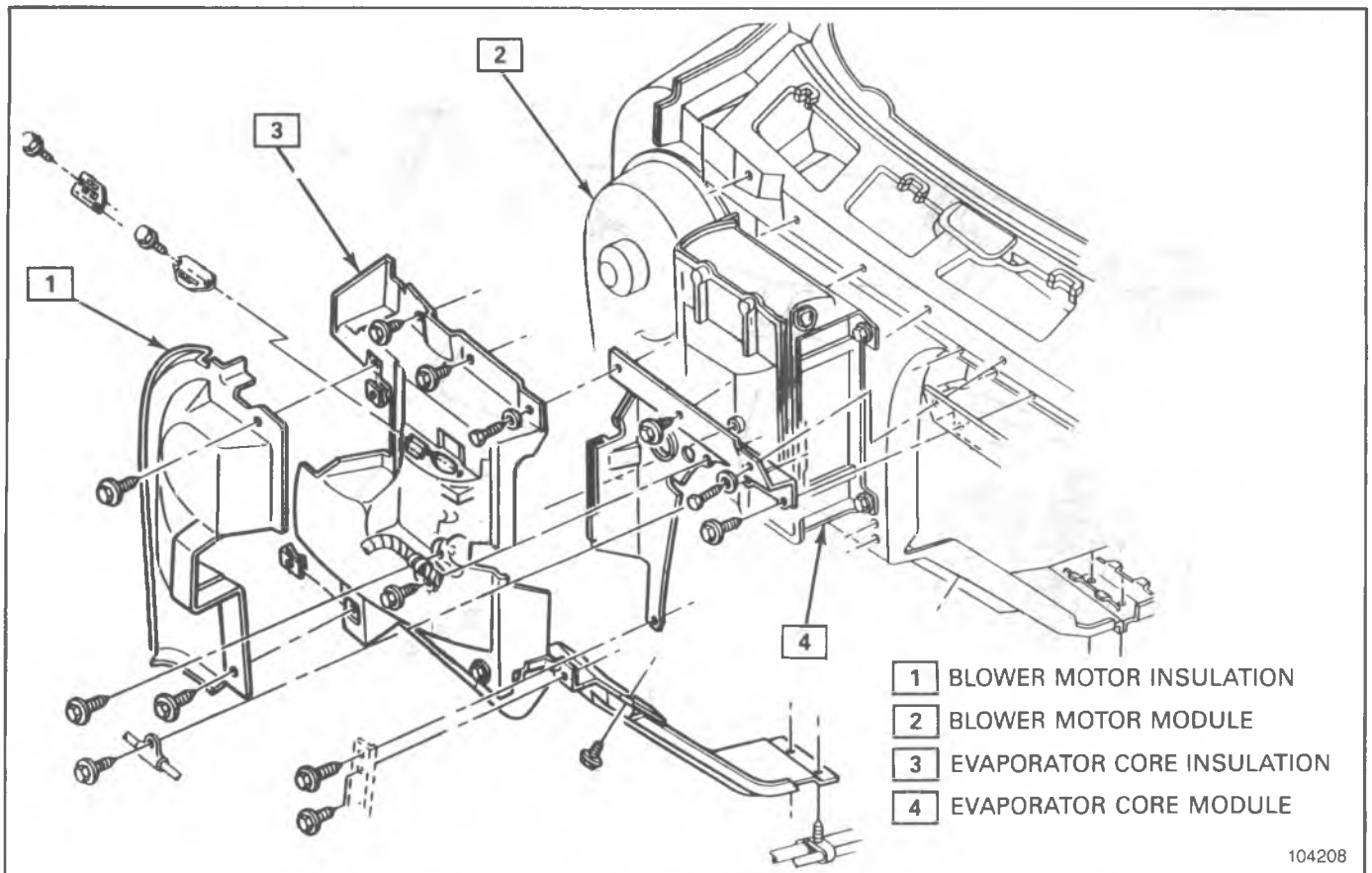

Fig. 1B-46a--G Van Blower Motor

module to dash panel.

10. Remove core case assembly from vehicle.
11. Remove screws and separate case sections.
12. Remove evaporator core.
13. To install new core, reverse Steps 3 thru 14 above.
14. Add 90 ml (3 oz.) 525 viscosity refrigeration oil to a new condenser.
15. Evacuate charge and check the system.

## TEMPERATURE DOOR CABLE - G SERIES

### Replacement

Follow Steps 1 thru 10 of "Heater Air Distributor and Extension Duct Replacement" procedure.

11. Disconnect temperature door control cable at heater case.
12. Disconnect temperature door control cable at control.
13. Make up new cable.
14. To reassemble, Reverse Steps 1 thru 13.

## CONTROL - G SERIES

### Replacement (Fig. 1B-48)

1. Disconnect the battery ground cable.
2. Remove the headlamp switch control knob.
3. Remove the instrument panel bezel.
4. Remove the control to instrument panel attaching screws.

5. Remove the temperature cable eyelet clip and mounting tab screw.
6. Pull the control through the instrument panel opening as follows: First pull the lower right mounting tab through the opening, then the upper tab and finally the lower right tab.
7. Disconnect electrical and vacuum connections and remove the control assembly.
8. To install, reverse Steps 1 thru 7 above. Check temperature door operation; adjust if necessary.

## BLOWER SWITCH

### Replacement (Fig. 1B-48)

1. Disconnect the battery ground cable.
2. Remove the left foot cooler outlet assembly at the instrument panel attachment.
3. Disconnect the switch electrical harness.
4. Remove the switch mounting screws and remove the switch.
5. To install, reverse Steps 1 thru 4 above.

## RESISTORS

### Replacement (Fig. 1B-49)

1. Disconnect electrical harness at the resistor.
2. Remove the resistor mounting screws and remove the resistor.
3. To install, reverse Steps 1 thru 3 above.

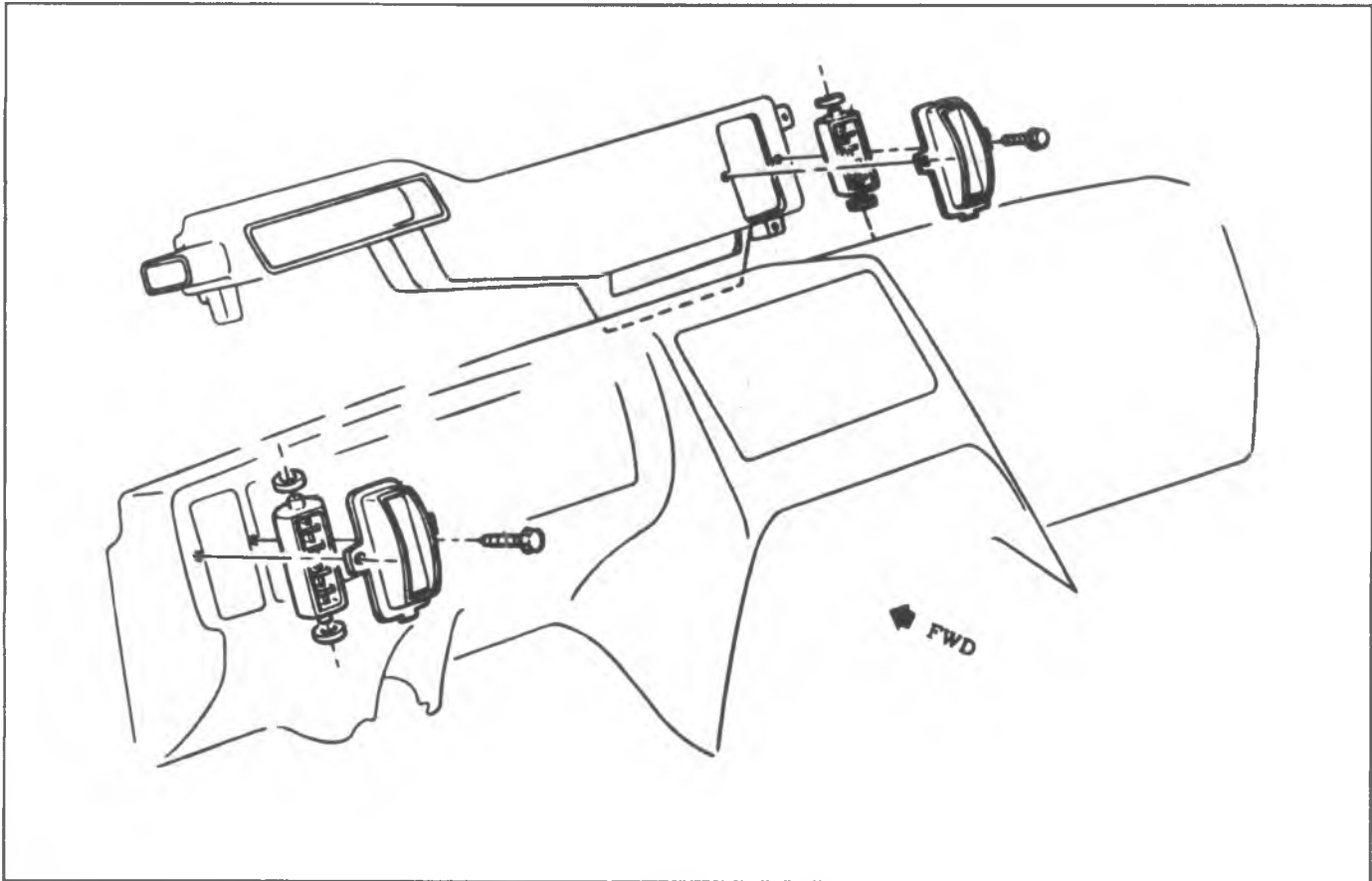

Fig. 1B-47--Air Deflector Outlets (G Series-C60 System)

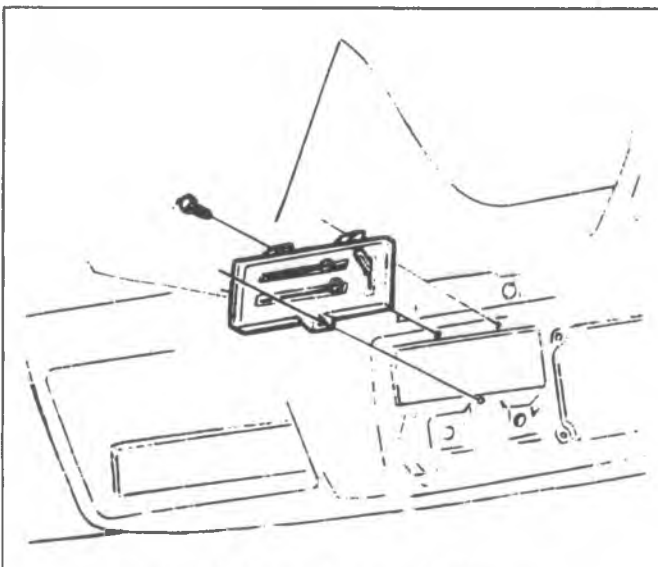

Fig. 1B-48--Control (G Series-C60 System)

### BLOWER MOTOR RELAY - G SERIES

#### Replacement (Fig. 1B-49)

1. Disconnect electrical harness at the relay.
2. Remove the relay mounting screw and remove the relay.

3. To install, reverse Steps 1 thru 3 above.

### CENTER A/C OUTLET - G SERIES

#### Replacement

1. Disconnect negative battery cable.
2. Remove engine cover (Refer to Section 6A).
3. Remove steering column to I.P. attaching screw.
4. Remove radio support bracket screw.
5. Remove I.P. attaching screws.
6. Pull right side of I.P. rearward.
7. Remove duct (distributor) attaching screws.
8. Remove center deflector.
9. To replace, reverse Steps 1 thru 8 above.

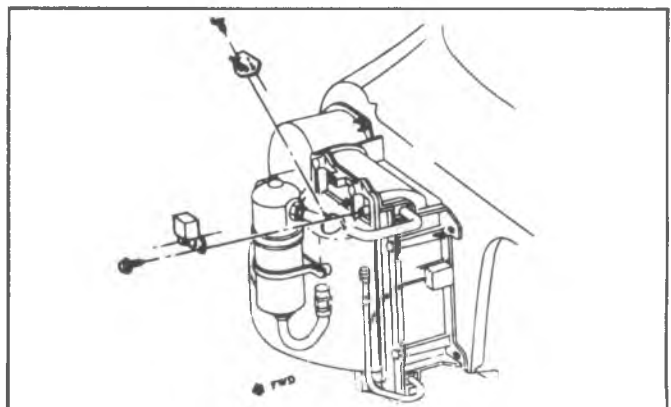

Fig. 1B-49--Blower Motor Relay

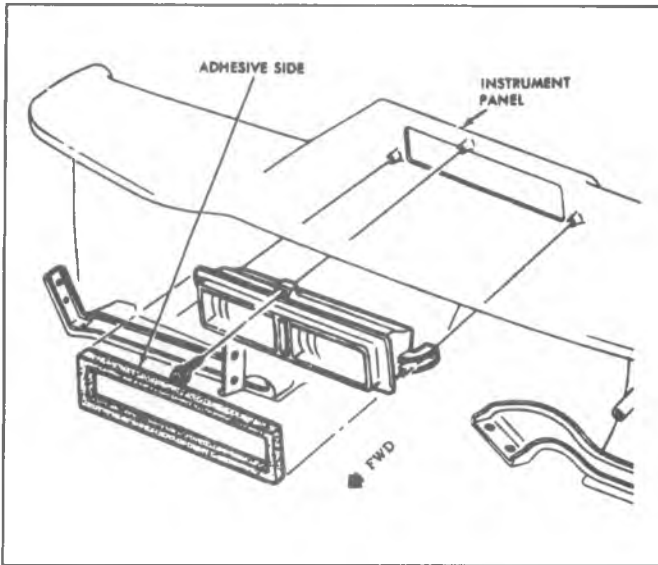

Fig. 1B-50--Center A/C Outlet Assembly-G Series

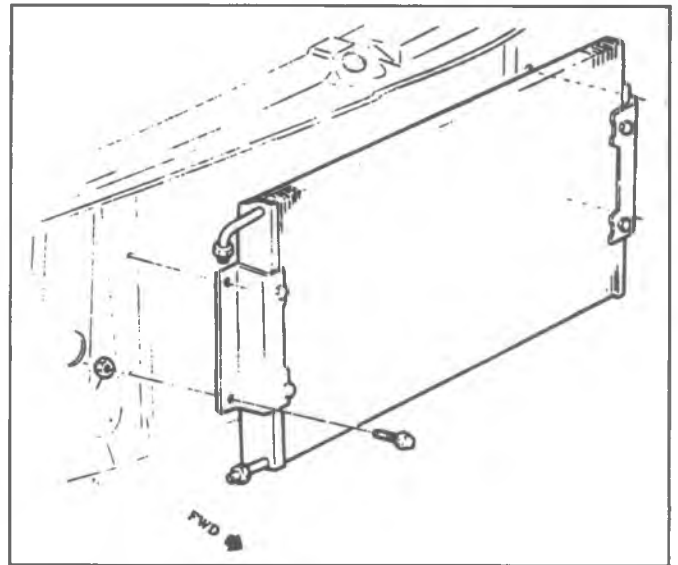

Fig. 1B-53--Condenser Installation-G Series

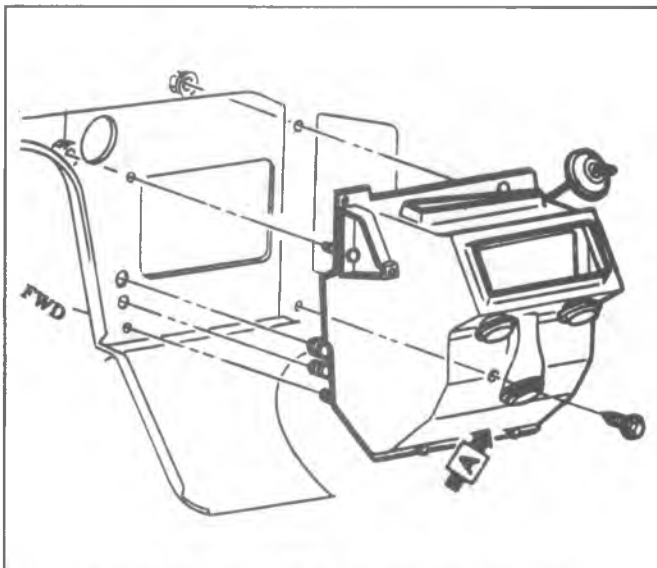

Fig. 1B-51--Heater Defroster Assembly-G Series

### VACUUM LINES-G VAN

#### Replacement

Vacuum line routing is illustrated in Fig. 1B-52.

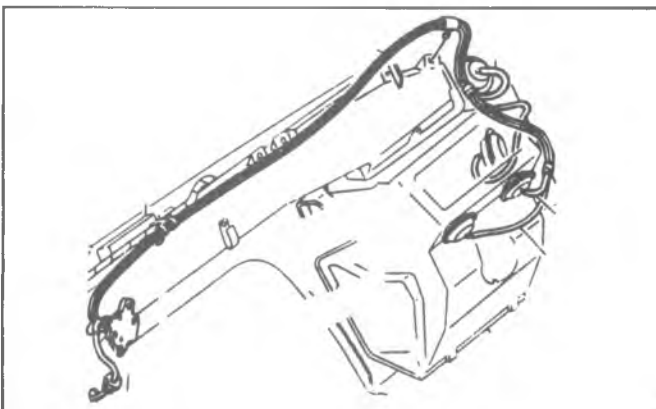

Fig. 1B-52--Vacuum Harness (G Series)

### A/C DUCTWORK

Air Conditioning duct attachment is shown in Fig. 1B-63.

### DEFROSTER DUCT

Defroster duct mounting is shown in Fig. 1B-64.

### TEMPERATURE DOOR CABLE

Temperature cable attachment and routing is shown in Fig. 1B-65.

### VACUUM TANK - G SERIES (Fig. 1B-60 & 1B-61)

#### Replacement

1. Raise the hood.
2. Disconnect the vacuum harness at the tank.
3. Remove the tank attaching screws and remove the tank.
4. To install, reverse Steps 1 thru 3 above.

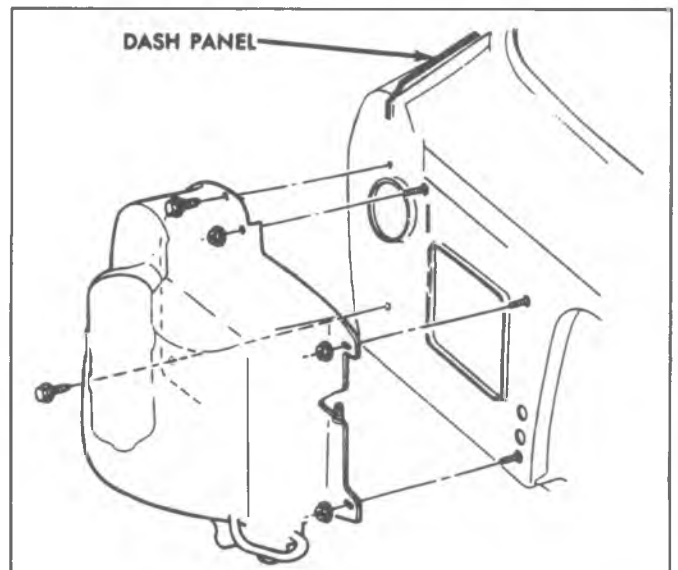

Fig. 1B-54--Evaporator Blower Assembly-G Series

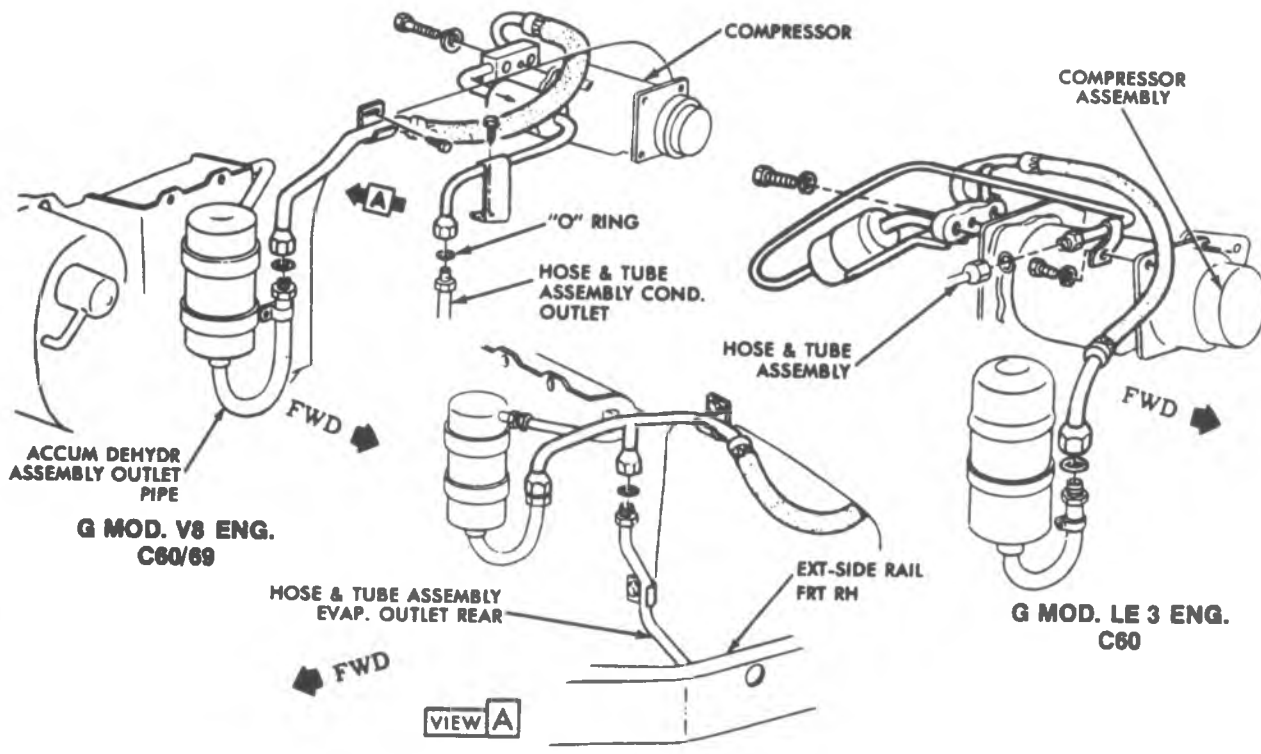

Fig. 1B-55--Refrigerant Lines - G Series

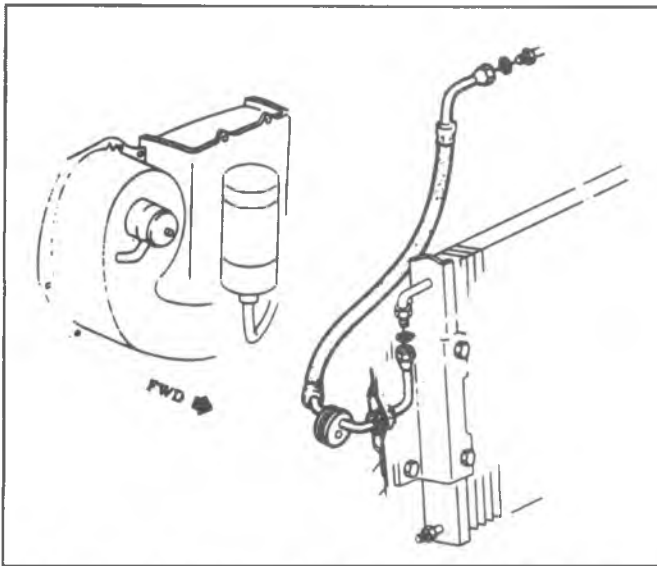

Fig. 1B-56--Refrigerant Lines-Condenser Inlet 6 Cyl Engine

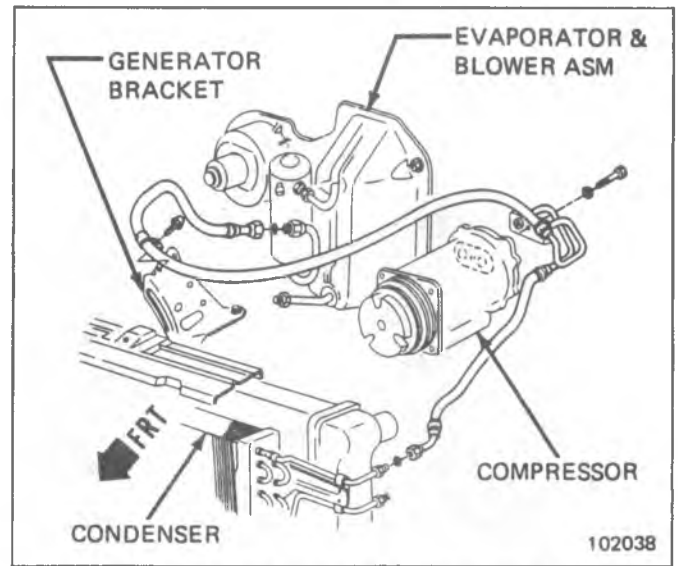

Fig. 1B-58--C-K Models Refrigerant Lines-V8

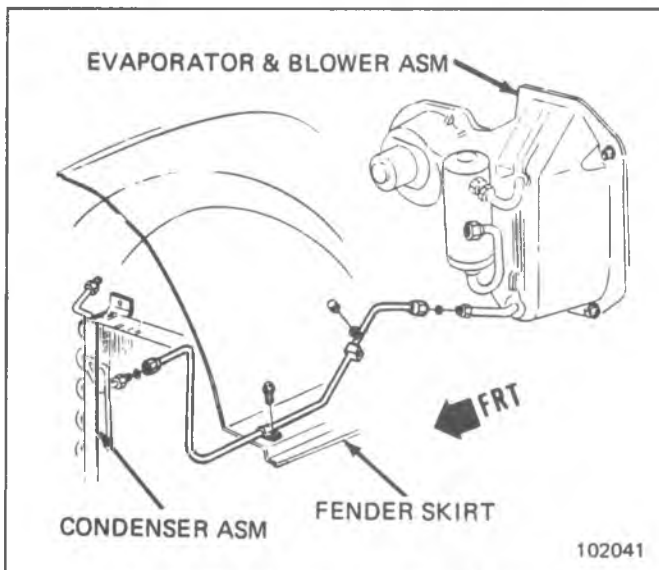

Fig. 1B-57--Refrigerant Lines-Diesel Engine

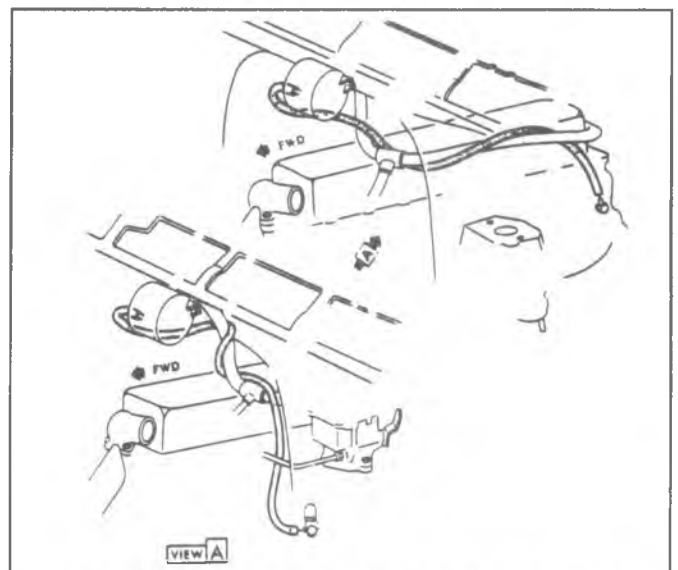

Fig. 1B-60--Vacuum Tank-G Series with 6 Cyl. Engine

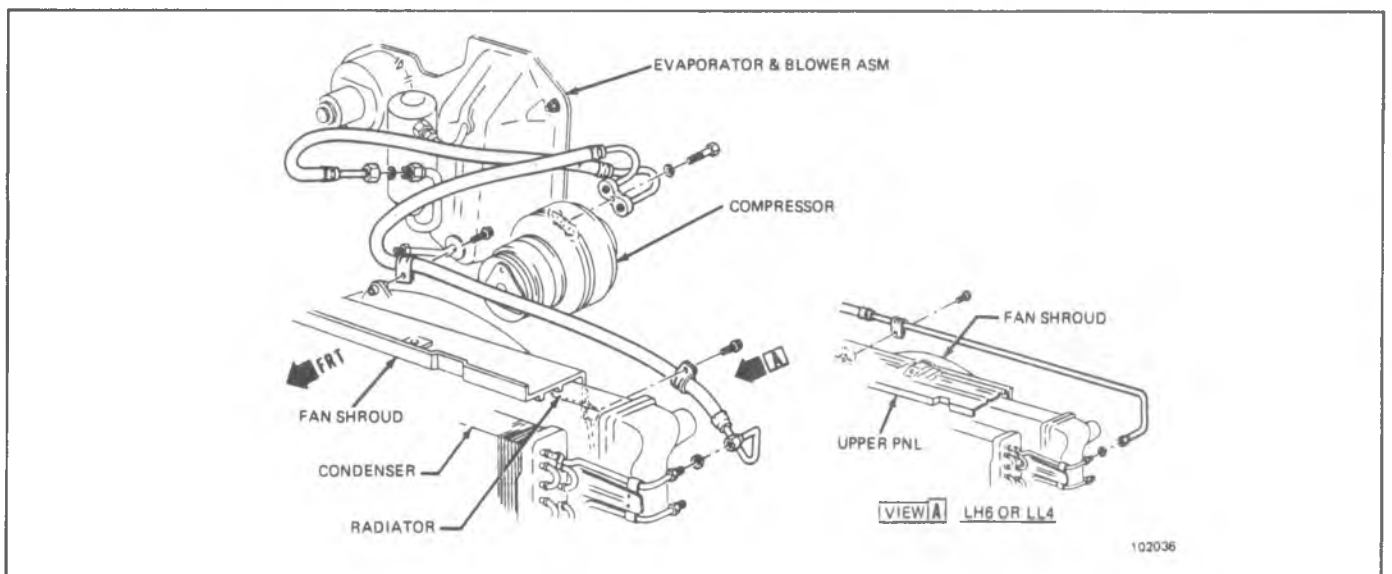

Fig. 1B-59--C-K Models Refrigerant Lines-L6

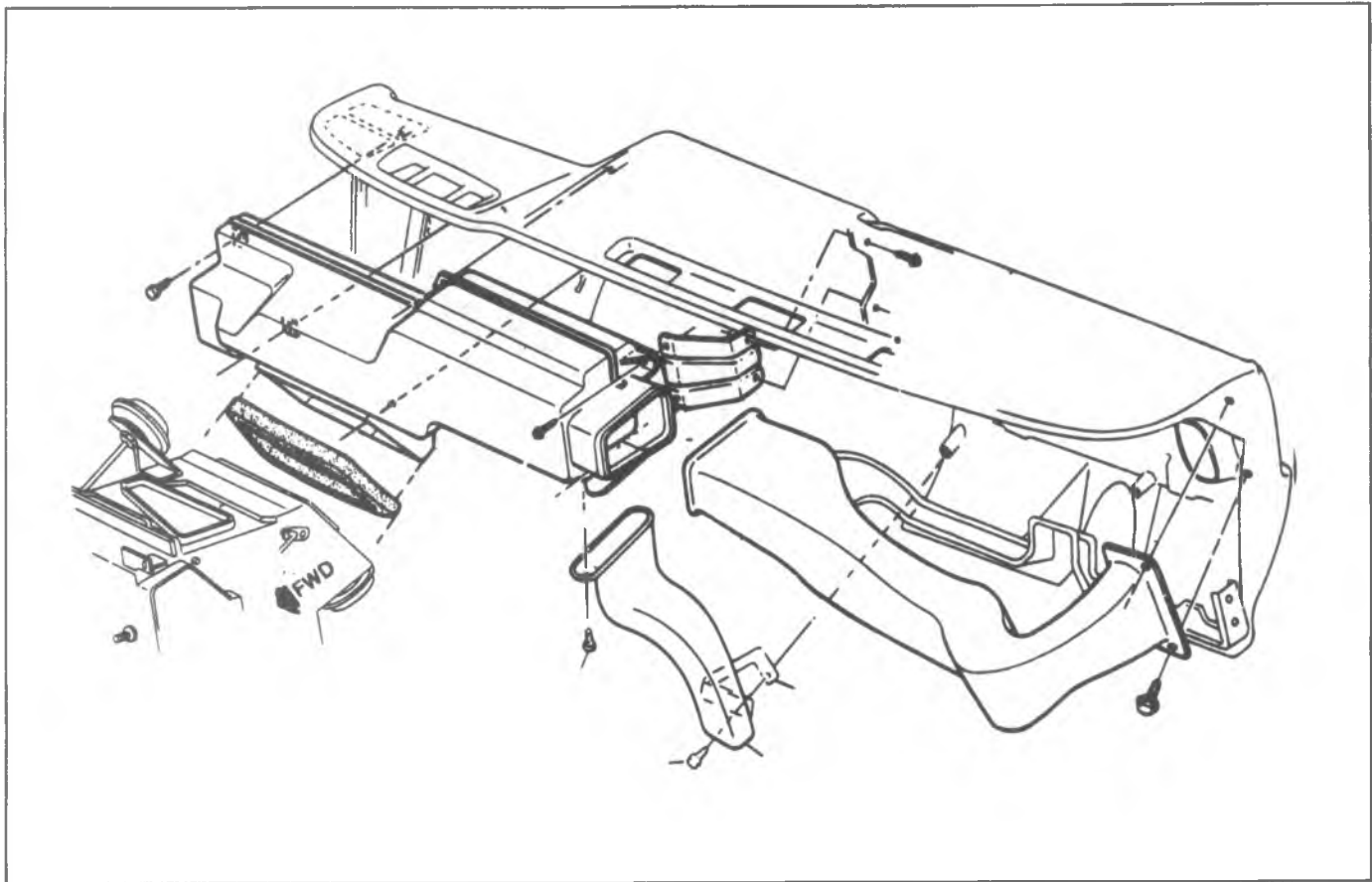

Fig. 1B-63--A/C Ducts-G Series

**CIRCUIT BREAKER**

The entire air conditioning system is protected by a 45 amp circuit breaker located on the left side of the dash, in the engine compartment.

**OVERHEAD SYSTEM--G SERIES**

This system is used in conjunction with the C60 system. The G Van C69 system is almost identical to the C-K

Models overhead system Refer to CK Series overhead system service procedures.

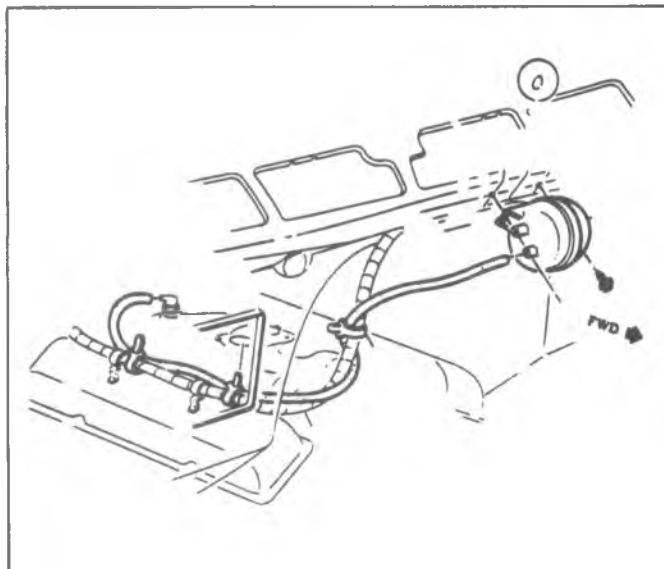

Fig. 1B-61--Vacuum Tank G Series-V8 Engine

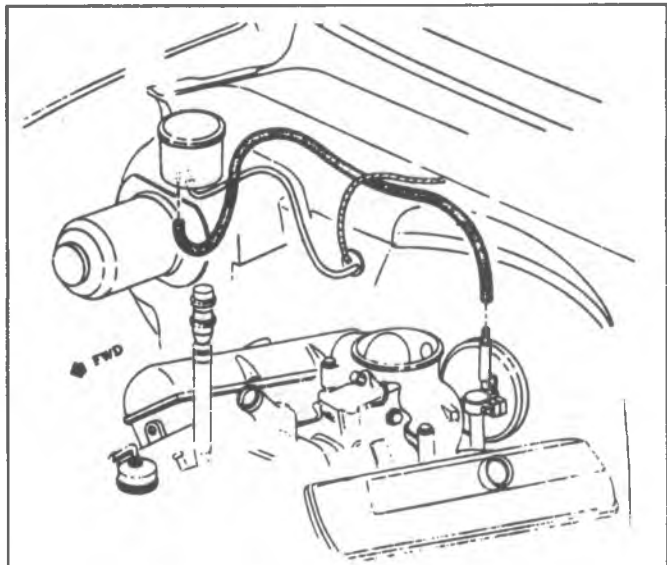

Fig. 1B-62--Vacuum Tank C-K Series-Diesel Engine

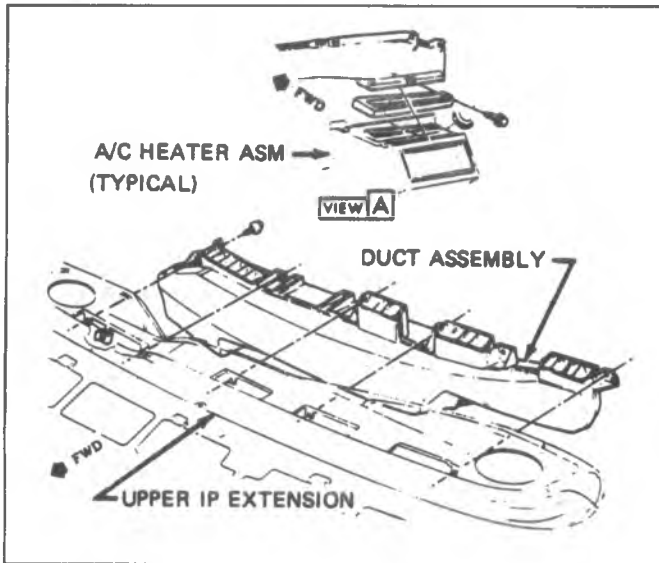

Fig. 1B-64--Defroster Duct-G Series

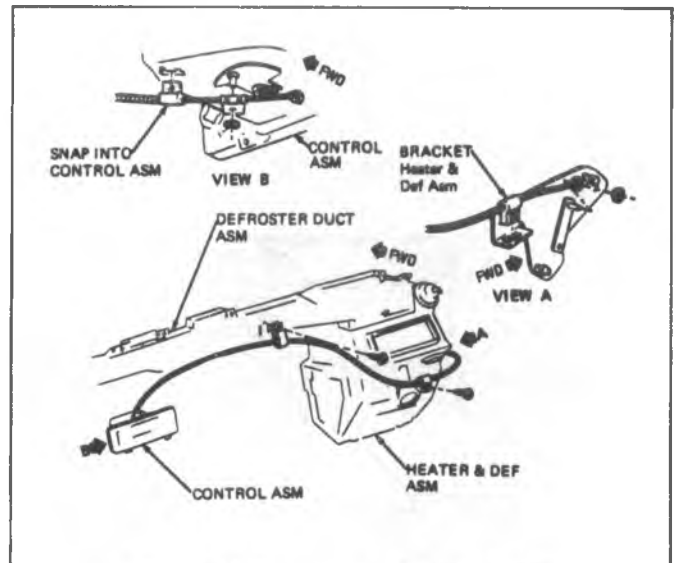

Fig. 1B-65--Temperature Cable-G Series

## DASH MOUNTED SYSTEM--MOTOR HOME CHASSIS

**NOTICE:** Use new "O" rings, coated with clean refrigeration oil, when connecting all refrigerant lines.

6. Evacuate, charge and check the system.

### RECEIVER-DEHYDRATOR

**Replacement (Fig. 1B-67)**

1. Disconnect the battery ground cable.
2. Purge the system of refrigerant.
3. Disconnect the inlet and outlet lines at the receiver-dehydrator and cap or plug the open lines at once.
4. Remove the receiver-dehydrator bracket attaching screws and remove the bracket and receiver-dehydrator.
5. To install a new receiver-dehydrator, reverse Steps 1 thru 4 above. Add one fluid ounce of clean

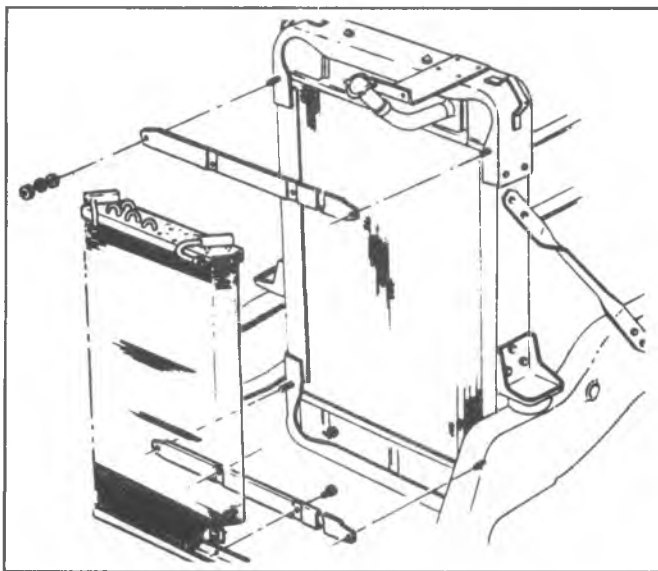

Fig. 1B-66--Condenser (Motor Home Chassis Unit)

This system is installed on the vehicle and checked at assembly. The blower-evaporator is then disconnected and shipped with the chassis unit to the body supplier. For this reason, it will only be possible to give basic replacement procedures on some components.

### CONDENSER

**Replacement (Fig. 1B-66)**

1. Disconnect the battery ground cable.
2. Purge the system of refrigerant.
3. Disconnect the condenser inlet and outlet lines and cap or plug all open connections at once.
4. Remove the condenser to radiator support screws and remove the condenser.
5. To install a new condenser, reverse Steps 1 thru 4 above. Add one fluid ounce of clean refrigeration oil to a new condenser.

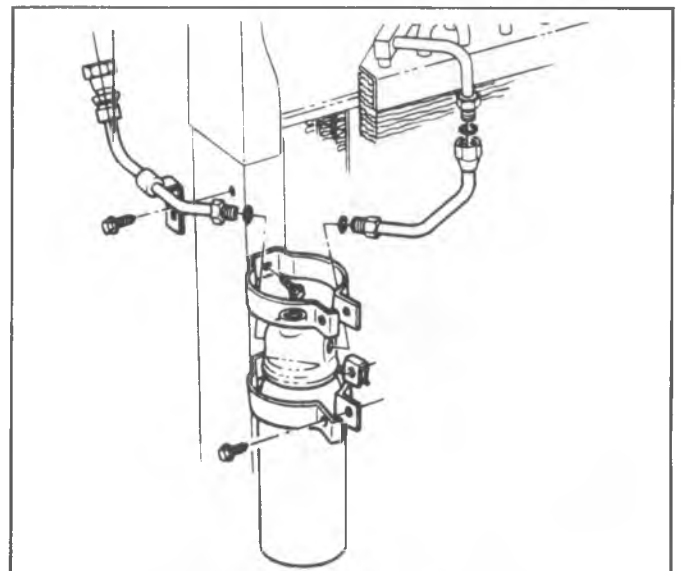

Fig. 1B-67--Receiver-Dehydrator (Motor Home Chassis Unit)



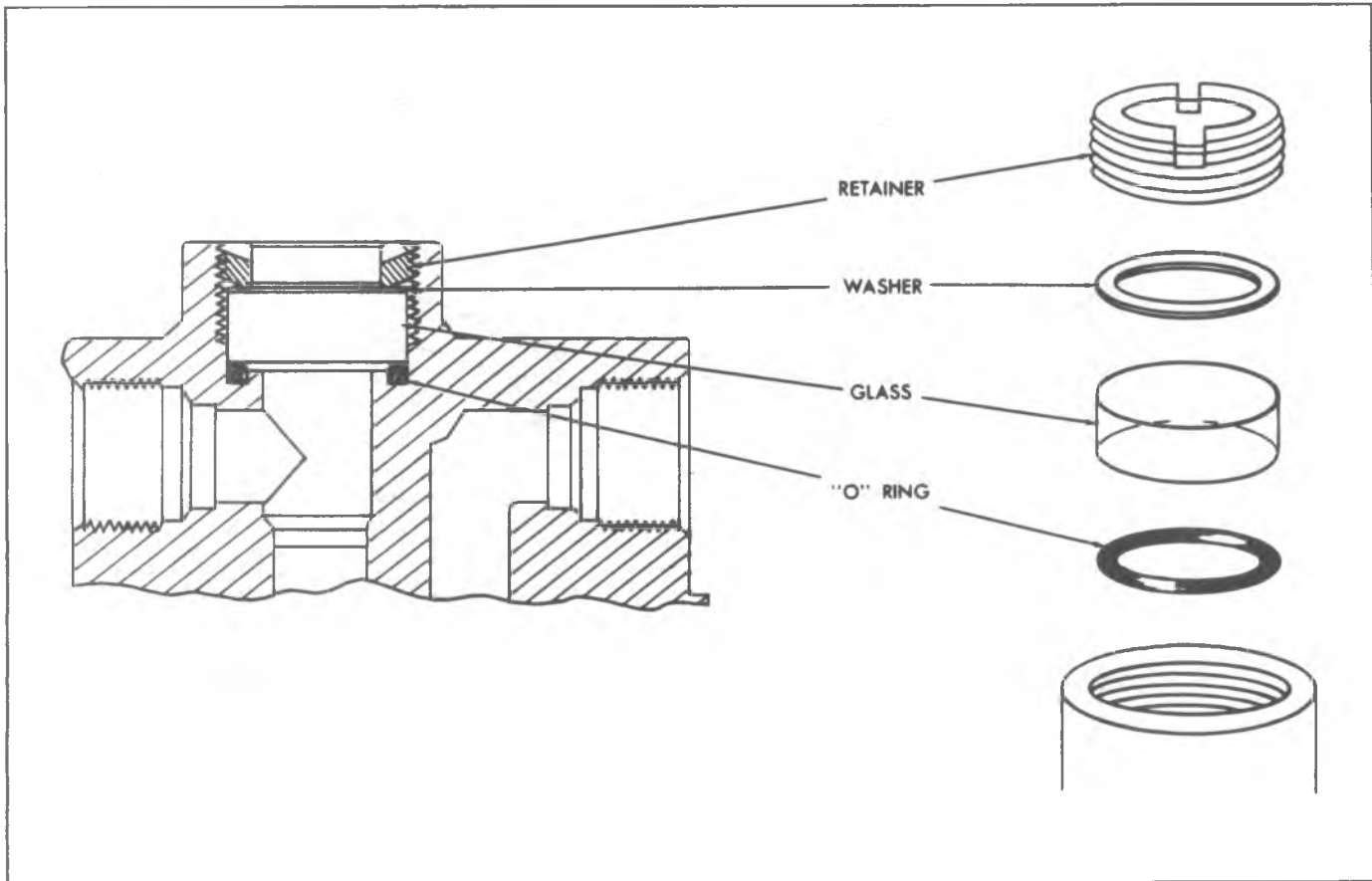

Fig. 1B-68--Sight Glass Replacement

refrigeration oil to a new receiver-dehydrator.

**NOTICE:** Use new "O" rings, coated with clean refrigeration oil, when connecting all refrigerant lines.

6. Evacuate, charge and check the system.

### SIGHT GLASS REPLACEMENT

If damage to the sight glass should occur, a new sight glass kit should be installed. The kit contains the sight glass, seal and retainer. (Refer to Fig. 1B-68).

1. Purge system.
2. Remove the sight glass retainer nut using a screwdriver and remove old glass and "O" ring seal.
3. Install the new glass and seal and retainer nut,

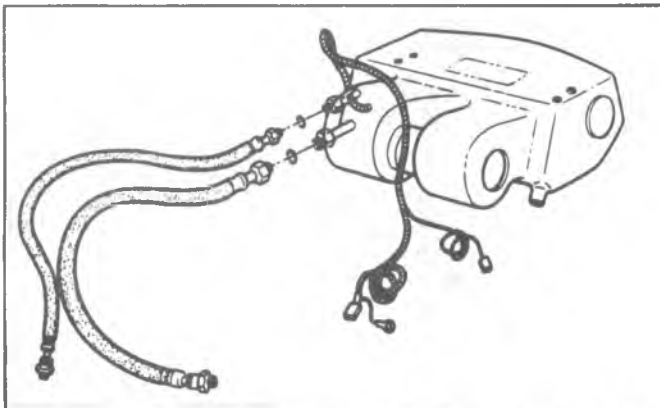

Fig. 1B-69--Blower-Evaporator (Motor Home Chassis Units)

being careful not to turn the nut past the face of the housing. To do so may damage the "O" ring seal.

4. Evacuate, charge and check the system.

### BLOWER-EVAPORATOR ASSEMBLY (Fig. 1B-69)

#### Removal

1. Disconnect battery ground cable.
2. Purge system of refrigerant.
3. Disconnect inlet and outlet refrigerant lines from the back of unit. Cap or plug all open connections at once.
4. Disconnect drain tubes from evaporator case.
5. Disconnect electrical connector from compressor. Remove the terminal (Refer to Fig. 1B-70) and allow connector to hang on ground wire.
6. Remove screws securing grommet retainer to dash panel. Remove wire from grommet through slit.
7. Disconnect electrical lead at connector.
8. Remove unit mounting bolts. Remove unit from vehicle, carefully pulling compressor electrical lead through dash panel.

Once the unit has been removed from the vehicle, continue with component replacement as follows:

### BLOWER ASSEMBLY

#### Removal (Fig. 1B-71)

1. Remove the cover plate and separate the upper and



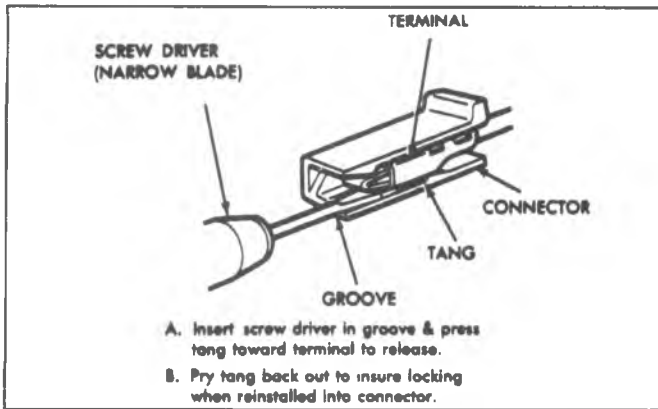

Fig. 1B-70--Terminal Removal

lower case halves. Remove blower motor mounting strap screw and remove strap.

2. Remove blower assembly. Remove the wheels from the motor shaft.

**Installation**

1. Install the blower wheels on the motor so that the lower blades curve toward the dash panel side of the unit when the motor is placed in the case as shown in Fig. 1B-85.
2. Place the motor in the bracket with the electrical connector side of the motor to the right side of the bracket. Attach the mounting strap. Align blower wheels so that they do not contact case.
3. Assemble the case halves and attach the cover plate.
4. Reverse Steps 1-8 on the "Blower-Evaporator Assembly" removal procedure.
5. Evacuate, charge and check the system.

**EXPANSION VALVE, EVAPORATOR AND/OR EVAPORATOR CASE**

**Removal (Fig. 1B-72)**

1. Remove the cover plate and separate upper and lower case halves.
2. Remove inlet and outlet lines from the expansion valve. Remove sensing bulb from the evaporator outlet manifold. Remove expansion valve. Cap or plug open connections at once.
3. Remove evaporator core retaining screws and remove

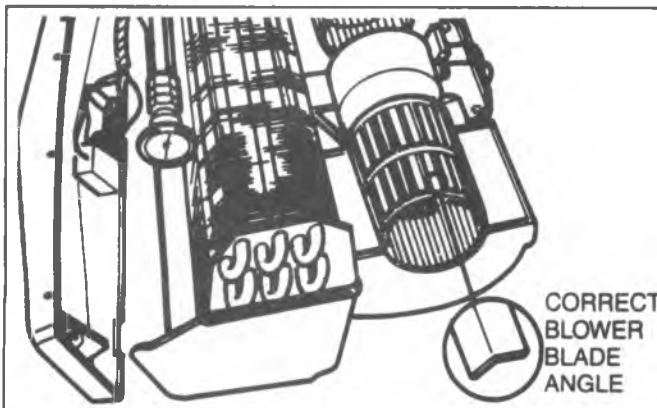

Fig. 1B-71--Blower Assembly (Motor Home Chassis Unit)

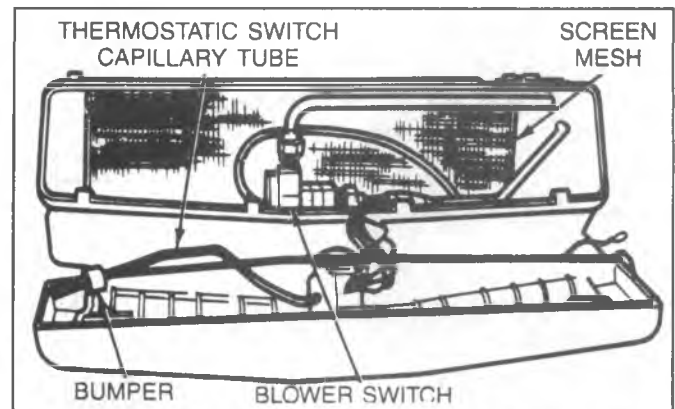

Fig. 1B-72--Expansion Valve (Motor Home Chassis Unit)

core.

4. Remove blower motor and harness assembly from case.

**Installation**

1. Reverse applicable steps in the removal procedure.

**NOTICE:** Use new "O" rings coated with clean refrigeration oil when connecting lines. Add 3 oz. of new refrigeration oil to a new core.

2. Reverse steps 1 thru 8 of the "Blower Evaporator Assembly" removal procedure.
3. Evacuate, charge and check the system.

**THERMOSTATIC AND/OR BLOWER SWITCHES**

**Replacement**

1. Remove the cover plate assembly from the evaporator case.
2. Remove two screws securing either switch to the cover plate and remove appropriate switch (Fig. 1B-73).
3. Install replacement switch, reinstall cover plate and reverse steps 1-8 of the "Blower-Evaporator Assembly" removal procedure.

When installing thermostatic switch, be sure to position sensing capillary as when unit was removed.

**RESISTOR**

The blower motor resistor is located on the top of the unit. The entire unit must be removed to replace the resistor.

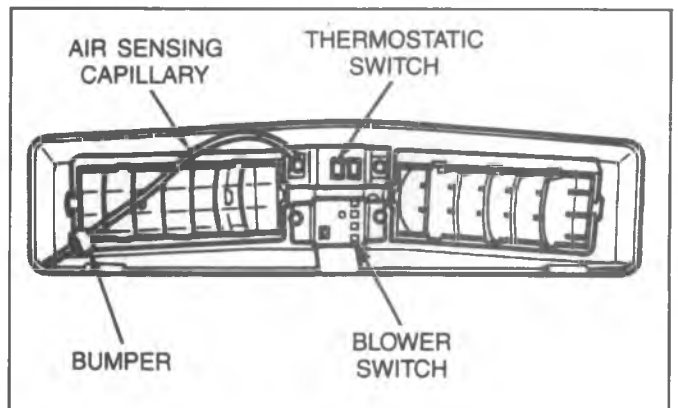

Fig. 1B-73--Thermostatic and Blower Switches

**FUSE**

This Unit does not incorporate an in-line fuse. The lead wire is connected to the Heater Wiring Harness and operates off the 20 amp Heater Fuse.

**SPECIFICATIONS**

**AIR CONDITIONING**

**Compressor**

Type . . . . . 6 Cylinder Axial  
 . . . . . 4 Cylinder Radial

**Displacement**

6 Cylinder Axial . . . . . 12.6 Cu. In.  
 4 Cylinder Radial . . . . . 10.0 Cu. In.

Rotation . . . . . Clockwise  
 . . . . . RPM  
 . . . . . (Cold)

**Blower Motor**

|   | <u>Volts</u> | <u>Amps.</u><br><u>(Cold)</u> | <u>RPM</u><br><u>(Cold)</u> |
|---|--------------|-------------------------------|-----------------------------|
| C-K Four Season . . . . .                                       | 12.0         | 12.9 Max.                     | 3400 Min.                   |
| C-K-G Overhead,<br>G Floor and<br>Motor Home<br>Units . . . . . | 12.0         | 13.7 Max.                     | 3400 Min.                   |

**Compressor Clutch Coil**

Ohms (at 80°F) . . . . . 3.70  
 Amps. (at 80°F) . . . . . 3.33 @ 12 volts

**Torque Specifications**

**Compressor Suction and Discharge**

|   |                   |
|---|-------------------|
| Connector Bolt . . . . .                        | 25 ft. lbs.       |
| Rear Head to Shell Stud Nuts (6 Cyl.) . . . . . | 23 ft. lbs.       |
| Shaft Mounting Nut (6 Cyl.) . . . . .           | 20 ft. lbs.       |
| Shaft Mounting Nut (4 Cyl.) . . . . .           | 8-12 ft. lbs.     |
| High Pressure Relief Valve (6 Cyl.) . . . . .   | 12 ft. lbs.       |
| Oil Charge Screw (6 Cyl.) . . . . .             | 14 ft. lbs.       |
| Air Gap on Clutch (6 Cyl.) . . . . .            | .022 to .057 in.  |
| Compressor Mounting Bracket . . . . .           | 35 ft. lbs.       |
| Compressor to Front Bracket Bolts . . . . .     | 25 ft. lbs.       |
| Belt Tension . . . . .                          | See Tune-Up Chart |

**Fuse Block—**

|                                   |         |
|-----------------------------------|---------|
| C-K Systems . . . . .             | 25 Amp. |
| Motor Home Chassis Unit . . . . . | 20 Amp. |

**In-Line—**

|                                   |         |
|-----------------------------------|---------|
| C-K Systems . . . . .             | 25 Amp. |
| Motor Home Chassis Unit . . . . . | None    |

**Circuit Breaker**

|                           |         |
|---------------------------|---------|
| G Model Systems . . . . . | 45 Amp. |
|---------------------------|---------|

### SPECIAL TOOLS

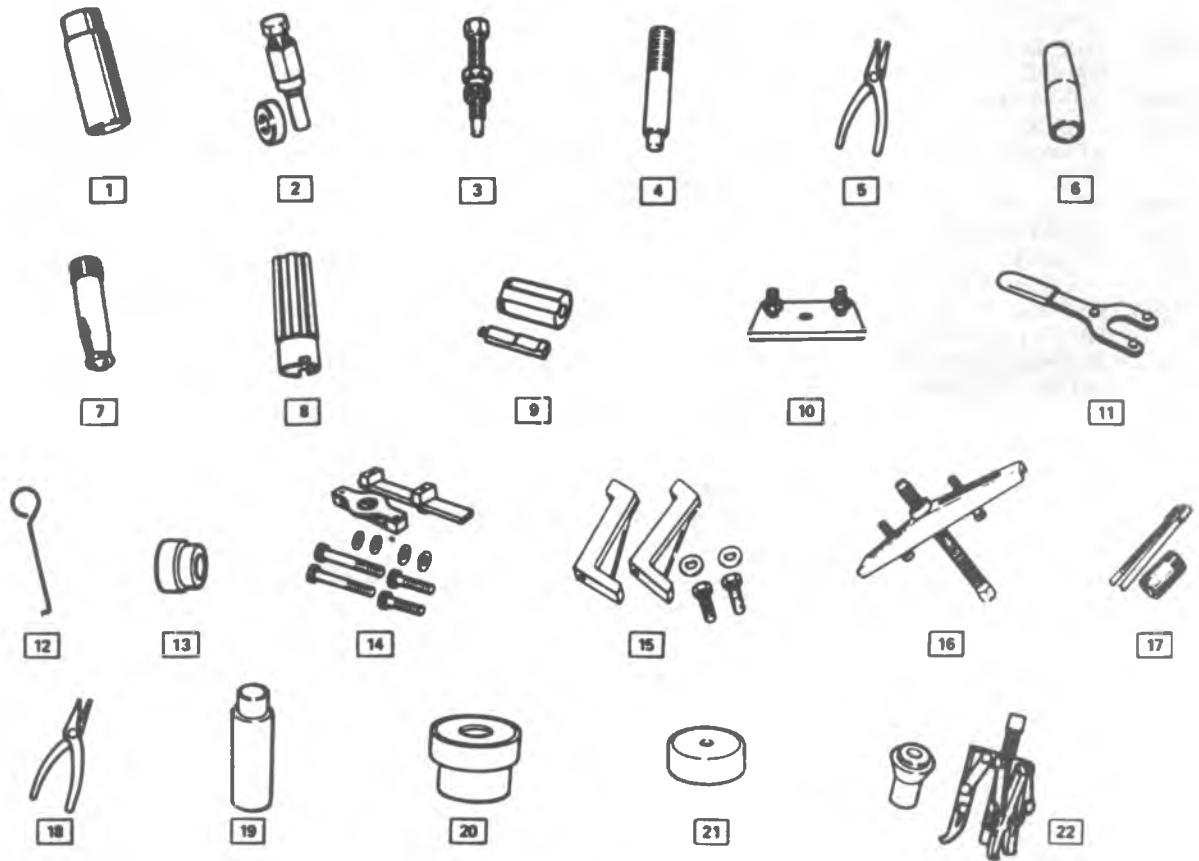

- |   |  |
|---|--|
| <p><b>1</b> J 9398 9/16" THIN WALL SOCKET</p> <p><b>2</b> J 9480-01 HUB AND DRIVE PLATE ASSEMBLY INSTALLER</p> <p><b>3</b> J 9401 HUB AND DRIVE PLATE ASSEMBLY REMOVER</p> <p><b>4</b> J 8092 DRIVER HANDLE</p> <p><b>5</b> J 5403 SNAP RING PLIERS (#21 INTERNAL)</p> <p><b>6</b> J 22974 SHAFT SEAL PROTECTOR</p> <p><b>7</b> J 23128 SEAL SEAT REMOVER AND INSTALLER</p> <p><b>8</b> J 9392 SHAFT SEAL REMOVER AND INSTALLER</p> <p><b>9</b> J 21508 SEAL SEAT O-RING INSTALLER</p> <p><b>10</b> J 9625 PRESSURE TEST CONNECTOR</p> <p><b>11</b> J 25030 CLUTCH HUB HOLDING TOOL</p> | <p><b>12</b> J 9553-01 O-RING REMOVER</p> <p><b>13</b> J 9398 ROTOR BEARING REMOVER</p> <p><b>14</b> J 25008 COMPRESSOR HOLDING FIXTURE</p> <p><b>15</b> J 24092 PULLEY HUB ADAPTER SET (USED WITH J 8433)</p> <p><b>16</b> J 8433 COMPRESSOR PULLEY PULLER</p> <p><b>17</b> J 9393 SEAL SEAT REMOVER &amp; INSTALLER</p> <p><b>18</b> J 6083 SNAP RING PLIERS (#24 EXTERNAL)</p> <p><b>19</b> J 24896 BEARING REMOVER (FRONT HEAD)</p> <p><b>20</b> J 26271 ROTOR AND BEARING INSTALLER (WITHOUT HANDLE)</p> <p><b>21</b> J 24896 BEARING INSTALLER (FRONT HEAD)</p> <p><b>22</b> J 25031-2 ROTOR AND BEARING PULLER WITH GUIDE</p> |
|---|--|

Fig. 1B-74--Air Conditioning Special Tools

|               |                                  |               |                                      |               |                                 |
|---------------|----------------------------------|---------------|--------------------------------------|---------------|---------------------------------|
| 1. J-8393     | CHARGING STATION                 | 11. J-5421-02 | POCKET THERMOMETERS (2)              | 22. J-9398    | PULLEY BEARING REMOVER          |
| 2. J-24095    | OIL INDUCER                      | 12. J-5403    | NO. 21 SNAP RING PLIERS              | 23. J-9481    | PULLEY AND BEARING INSTALLER    |
| 3. J-5453     | GOGGLES                          | 13. J-6435    | NO. 26 SNAP RING PLIERS              | 24. J-8092    | HANDLE                          |
| 4. J-9459     | 7/16"-20 90° GAUGE LINE          | 14. J-9396    | COMPRESSOR HOLDING FIXTURE           | 25. J-21352   | INTERNAL ASSEMBLY SUPPORT BLOCK |
| J-25499       | 3/8"-24 ADAPTER                  | 15. J-25030   | COMPRESSING FIXTURE                  | 26. J-5139    | OIL PICKUP TUBE REMOVER         |
| 5. J-5420     | 7/16"-20 STRAIGHT GAUGE LINE     | 16. J-9403    | CLUTCH HUB HOLDING TOOL              | 27. J-9432    | NEEDLE BEARING INSTALLER        |
| J-25498       | 3/8" ADAPTER                     | 17. J-9399    | 9/16" THIN WALL SOCKET               | 28. J-9553-01 | SEAL SEAT "O" RING REMOVER      |
| 6. J-6084     | LEAK DETECTOR                    | 18. J-9401    | HUB AND DRIVE PLATE ASSEMBLY REMOVER | 29. J-21508   | SEAL SEAT "O" RING INSTALLER    |
| 7. J-8433     | PULLER                           | 19. J-9480-01 | HUB AND DRIVE PLATE ASSEMBLY REMOVER | 30. J-22974   | SHAFT SEAL PROTECTOR            |
| 8. J-9395     | PULLER PILOT                     | 20. J-9392    | SEAL REMOVER                         | 31. J-9625    | PRESSURE TEST CONNECTOR         |
| 9. J-23595    | REFRIGERANT CAN VALVE (SIDE-TAP) | 21. J-23128   | SEAL SEAT REMOVER                    | 32. J-9402    | PARTS TRAY                      |
| 10. J-6271-01 | REFRIGERANT CAN VALVE (TOP-TAP)  |               |                                      |               |                                 |

Fig. 1B-75--Air Conditioning Special Tools

## SECTION 1D

# AIR CONDITIONING COMPRESSOR OVERHAUL

For Compressor REMOVAL AND INSTALLATION, see Air Conditioning Section. For DISCHARGING, ADDING OIL, EVACUATING AND CHARGING PROCEDURES FOR C.C.O.T. A/C SYSTEMS, see Air Conditioning Section.

### CONTENTS OF THIS SECTION

|  |       |
|--|-------|
| Minor Repair Procedures for the A-6 Compressor.....  | 1D-2  |
| A-6 Compressor Clutch Plate and Hub Assembly.....    | 1D-2  |
| A-6 Compressor Pulley and Bearing Assy.....          | 1D-5  |
| A-6 Compressor Pulley Bearing.....                   | 1D-6  |
| A-6 Compressor Clutch Coil and Housing Assembly..... | 1D-7  |
| Major A-6 Compressor Repair Procedures.....          | 1D-8  |
| A-6 Compressor Shaft Seal.....                       | 1D-8  |
| Seal Leak Detection.....                             | 1D-10 |
| A-6 Compressor Pressure Relief Valve.....            | 1D-11 |
| A-6 Compressor Cylinder and Shaft Assembly.....      | 1D-13 |
| Removal.....   | 1D-13 |
| Disassembly.....                                     | 1D-13 |
| Gaging Operation.....                                | 1D-14 |
| A-6 Teflon Piston Ring Replacement.....              | 1D-18 |
| Assembly.....  | 1D-18 |
| Re-Install.....                                      | 1D-21 |
| A-6 Comp. Leak Testing (External and Internal).....  | 1D-25 |

For all practical purposes, all vehicles make use of the same air conditioning 4 and 6-cylinder compressors. Actual differences between compressors are found in their mounting brackets, pulleys, connector assemblies and compressor capacities, none of which will affect the following Overhaul Procedures.

When servicing the compressor, it is essential that steps be taken to prevent dirt or foreign material from getting on or into the compressor parts and system during disassembly

or reassembly of the compressor. Clean tools and clean work area are very important for proper service. The compressor connection areas and the exterior of the compressor should be cleaned off as much as possible prior to any "on car" repairs or removal of the compressor for workbench service. The parts must be kept clean at all times and any parts to be reassembled should be cleaned with naphtha, stoddard solvent, kerosene or equivalent solvent

and dried off with dry air. When necessary to use a cloth on any part, it should be of a non-lint producing type.

Although certain service operations can be performed without completely removing the compressor from the vehicle, the operations described herein are based on bench over-haul with the compressor removed from the vehicle. They have been prepared in sequence in order of accessibility of the components. Pad fender/skirt and secure compressor near top of fender skirt with wire, rope, etc. when performing on-car service.

When an A-6 or R-4 compressor is removed from the vehicle for servicing, the amount of oil remaining in the compressor should be drained and measured. This oil should then be discarded and new 525 viscosity refrigerant oil

added to the compressor (See Fig. 1D-1, and "C.C.O.T. Refrigerant Oil Distribution" in the Air Conditioning section).

Should an A-6 compressor, its compressor shaft seal or any other component ever be removed for servicing because it was determined to be the cause of excessive signs of oil leakage in the A/C system, then the oil in the A-6 compressor must be drained, measured and replaced according to "C.C.O.T. Refrigerant Oil Distribution" in the Air Conditioning section to determine oil loss. The accumulator in this A-6 system then must also be removed - oil drained - measured, etc. according to same section.

**NOTICE:** To avoid possible damage do not kink or place excessive tension on refrigerant lines or hoses.

## MINOR REPAIR PROCEDURES FOR THE A-6 COMPRESSOR

**THE FOLLOWING OPERATIONS TO THE A-6 COMPRESSOR CLUTCH PLATE AND HUB, PULLEY AND BEARING, AND COIL AND HOUSING ARE COVERED AS "MINOR" BECAUSE THEY MAY BE PERFORMED WITHOUT FIRST PURGING THE SYSTEM OR REMOVING THE COMPRESSOR from the vehicle.**

The Compressor Shaft Seal assembly and Pressure Relief Valve may also be serviced without removing the compressor from the vehicle but these operations are covered later in this section as "Major Repair Procedures" because the system must first be purged of Refrigerant-12.

Illustrations used in describing these operations show the compressor removed from the vehicle only to more clearly illustrate the various operations.

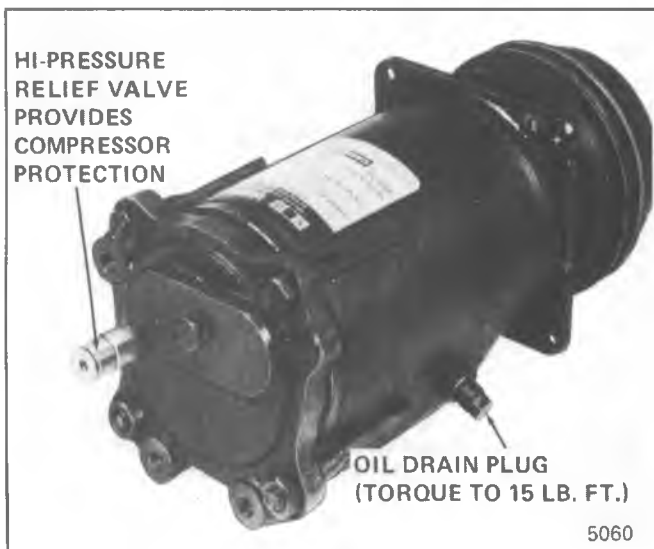

Fig. 1D-1 A-6 Compressor

When servicing the compressor, remove only the necessary components that preliminary diagnosis indicates

are in need of service. Refer to the AIR CONDITIONING section and Fig. 1D-2 and Fig. 1D-3 for information relative to parts nomenclature and location.

Removal and installation of external compressor components and disassembly and assembly of internal components must be performed on a clean workbench. **The work area, tools, and parts must be kept clean at all times.** Parts Tray J 9402 (Fig. 1D-33) should be used for all A-6 internal compressor parts being removed, as well as for replacement parts.

### A-6 COMPRESSOR CLUTCH PLATE AND HUB ASSEMBLY

#### Remove

1. Place Holding Fixture J 9396 in a vise and clamp the compressor in the Holding Fixture.
2. Keep clutch hub from turning with Clutch Hub Holder J 25030 or J 9403, and remove locknut from end of shaft using Thin Wall Socket J 9399 (Fig. 1D-3).

**NOTICE:** To avoid internal damage to the compressor, **DO NOT DRIVE OR POUND** on the Clutch Plate and Hub assembly **OR** on the end of the shaft. If proper tools to remove and replace clutch parts are not used, it is possible to disturb the position of the axial plate (keyed to the main shaft), resulting in compressor damage and seal leakage due to shifting of the crankshaft.

3. Thread Clutch Plate and Hub assembly Remover J 9401 into hub. Hold body of Remover with a wrench and tighten center screw to remove Clutch Plate and Hub assembly (Fig. 1D-4).
4. Remove square drive key from shaft or drive plate hub.
5. Inspect driven plate for cracks or stresses in the drive surface. Do not replace driven plate for a scoring condition (Fig. 1D-5).

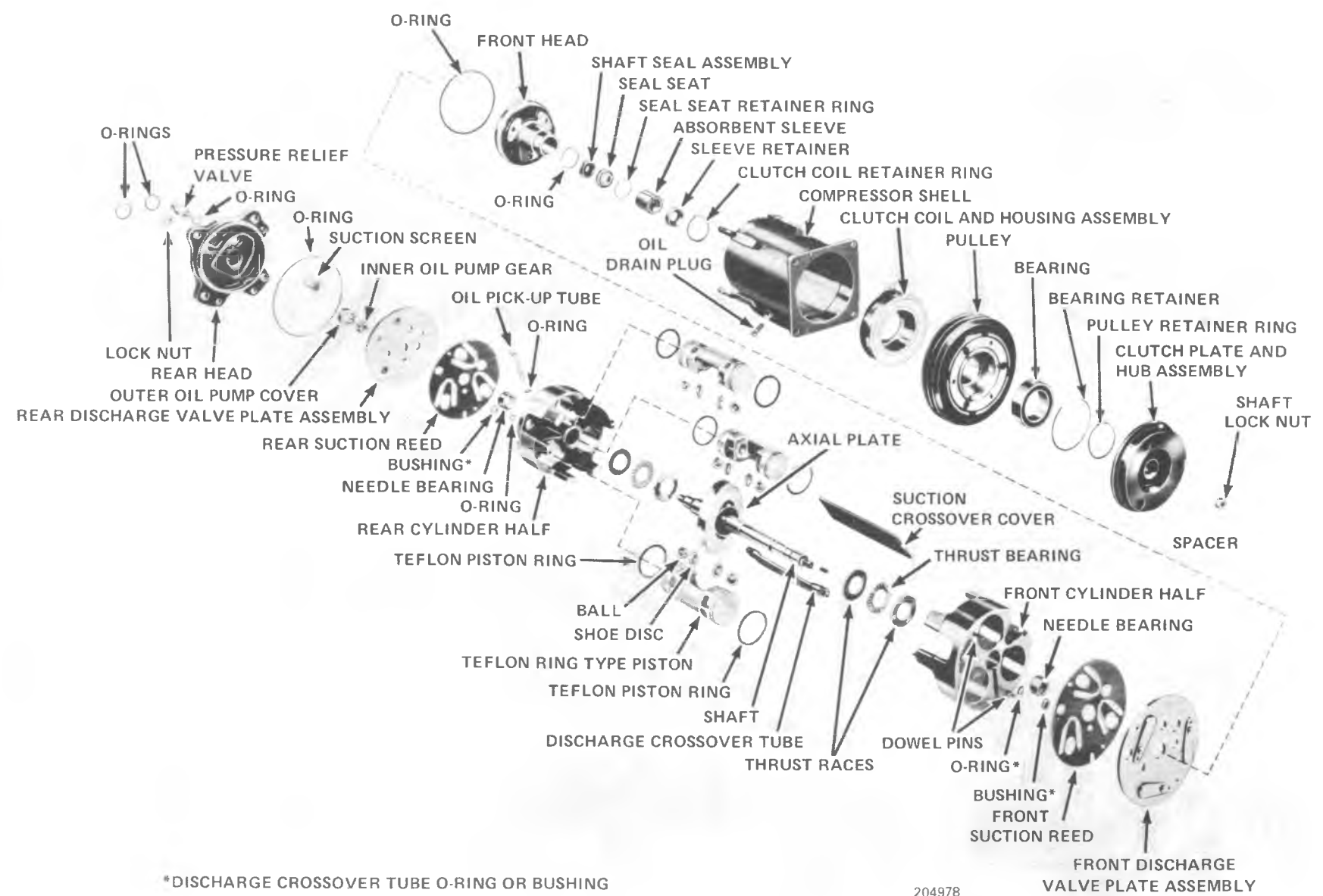

\*DISCHARGE CROSSOVER TUBE O-RING OR BUSHING

204978

Fig. 1D-2 Exploded View of A-6 Compressor

## 1D-4 AIR CONDITIONING COMPRESSOR OVERHAUL

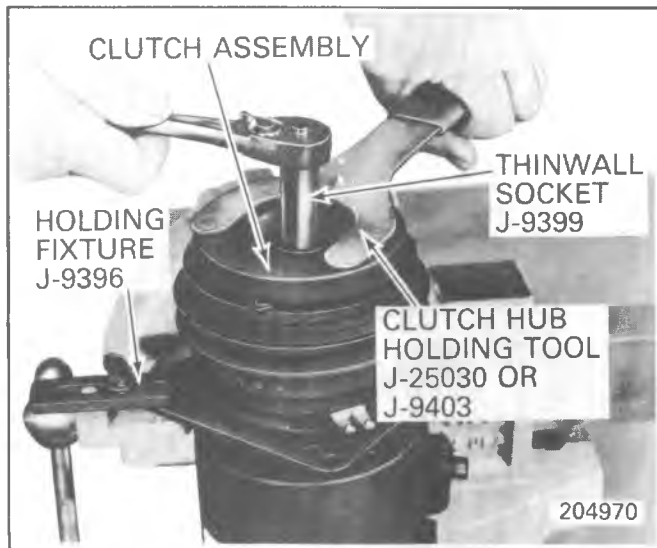

Fig. 1D-3 Removing A-6 Shaft Lock Nut

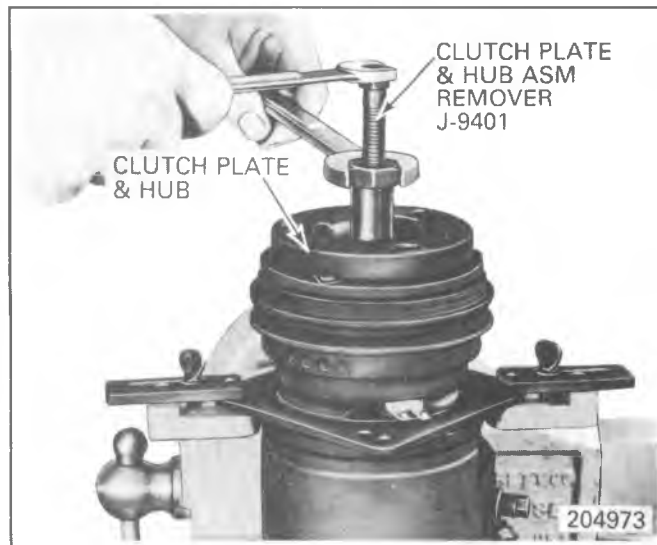

Fig. 1D-4 Removing A-6 Clutch Plate and Hub Asm.

If the frictional surface shows signs of damage due to excessive heat, the Clutch Plate and Hub and Pulley and Bearing should be replaced. Check further for the underlying cause of the damage (i.e. low coil voltage, coil should draw 3.2 amps at 12 volts) binding of the compressor internal mechanism (cylinder and shaft assembly), clutch air gap too wide (see Fig. 1D-8), broken drive plate to hub asm. springs, etc.

### Replace

1. Insert the square drive key into the hub of driven plate; allow it to project approximately 4.8mm (3/16") out of the keyway. The key has a slight curve for interference fit into hub keyway.

2. Line up the key in the hub with keyway in the shaft (Fig. 1D-6).

3. Install the Drive Plate Installer J 9480-1 as illustrated. This Installer has a left hand thread on the body (Fig. 1D-7).

4. Press the driven plate onto the shaft until there is approximately 2.4mm (3/32") space between the frictional

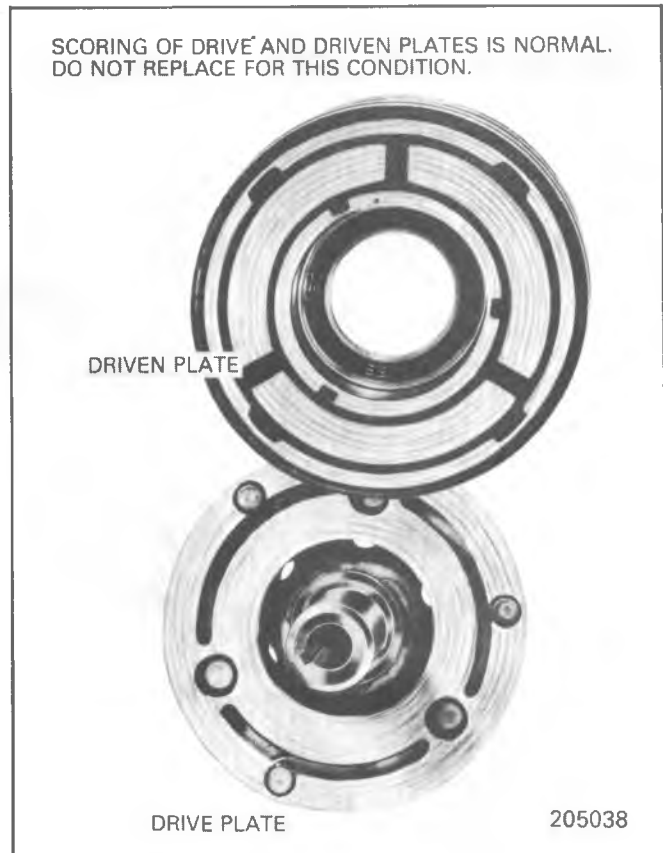

Fig. 1D-5 A-6 Clutch Driven Plate and Drive Plate

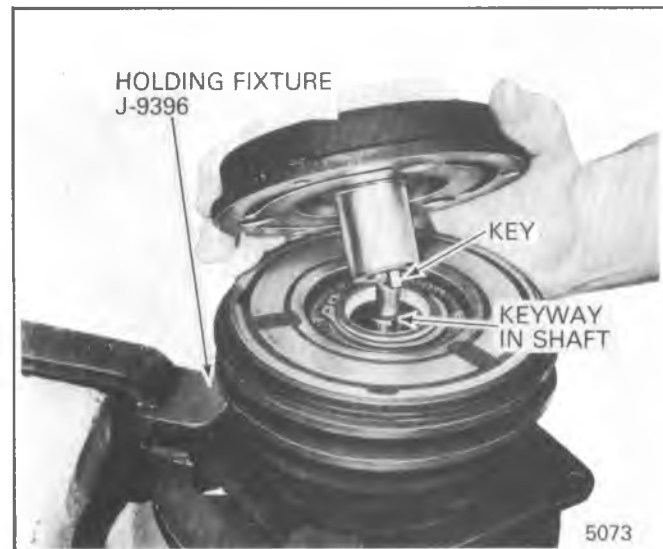

Fig. 1D-6 Aligning A-6 Drive Plate Key

faces of the Clutch Drive Plate and Pulley. Make certain key remains in place when pressing hub on shaft.

A zero thrust race is approximately 2.4mm (3/32") thick and may be used to roughly gage this operation. Use Clutch Hub Holder J 25030 or J 9403 to hold Clutch Plate and Hub if necessary.

6. Using Thin-Wall Socket J 9399 and Clutch Hub Holder J 25030 or J 9403 to install a new shaft locknut. Tighten the nut to 19 to 35 N·m (14-26 lb.ft.) torque. Air gap between the frictional faces should now be .6 to 1.4mm (.022" to .057") (Fig. 1D-8). If not, check for mispositioned key or shaft.



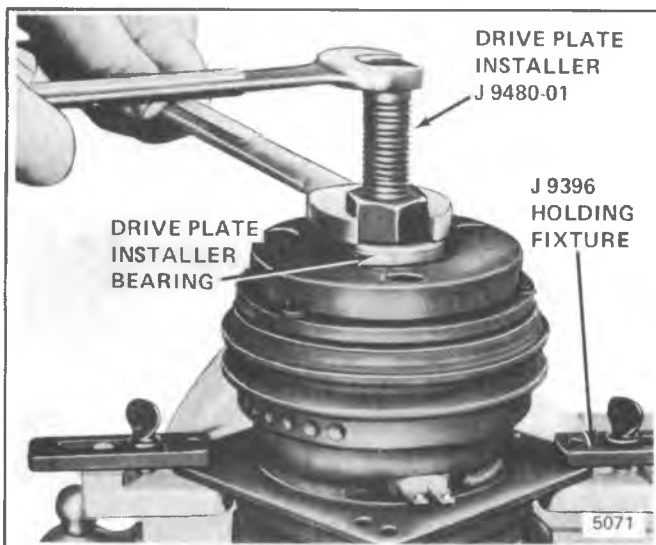

Fig. 1D-7 Installing A-6 Drive Plate

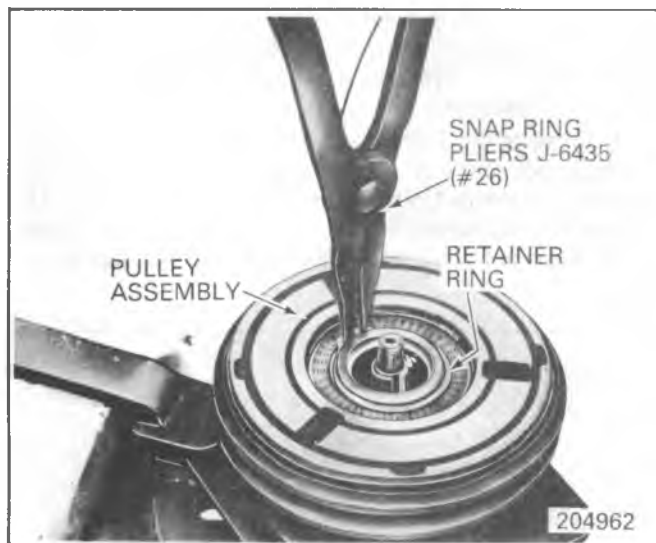

Fig. 1D-9 Removing A-6 Pulley Retainer Ring

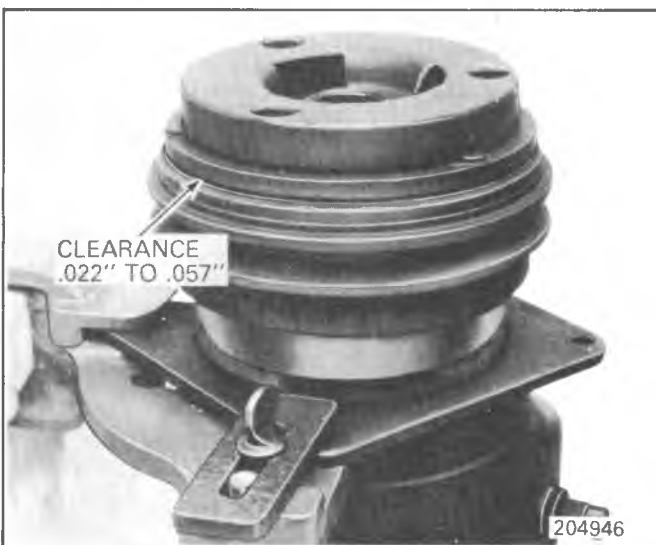

Fig. 1D-8 Checking A-6 Air Gap

**NOTICE:** It is important that Puller Pilot J 9395 be used to prevent internal damage to compressor when removing pulley. Under no circumstances should puller be used directly against threaded end of shaft.

5. Remove Pulley and Bearing Assembly, using Pulley Puller J 8433 (Fig. 1D-10).

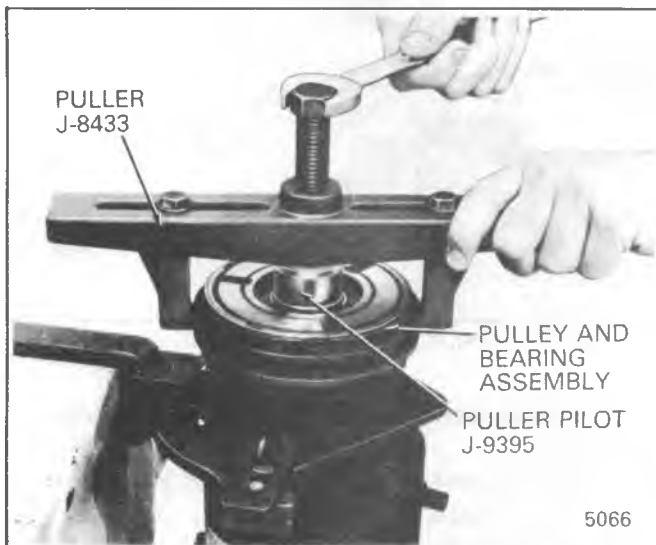

Fig. 1D-10 Removing A-6 Pulley and Bearing Asm.

7. The pulley should now rotate freely.

8. Operate the refrigeration system in the MAX A/C control selector (mode) lever position and warm engine (off fast idle) speed at 2000 RPM. Rapidly cycle the compressor clutch by turning the A/C control selector (mode) lever from OFF-to-MAX at least 15 times at approximately one second intervals to burnish the mating parts of the clutch.

## A-6 COMPRESSOR PULLEY AND BEARING ASSEMBLY

### Remove

1. Remove Clutch Plate and Hub assembly as described in "A-6 Compressor Clutch Plate and Hub Asm." Removal procedure.
2. Remove pulley retainer ring, using Snap-Ring Pliers J 6435, Fig. 1D-9.
3. Pry out absorbent sleeve retainer, and remove absorbent sleeve from compressor neck.
4. Place Puller Pilot J 9395 over end of compressor shaft.

### Inspection

Check the appearance of the Pulley and Bearing assembly (see Fig. 1D-5). The frictional surfaces of the Pulley and Bearing assembly should be cleaned with trichloroethane, naphtha, stoddard solvent, kerosene or equivalent solvent before reinstallation.

### Replace

1. If original Pulley and Bearing assembly is to be reinstalled, wipe frictional surface of pulley clean. If frictional surface of pulley shows any indication of damage due to overheating, the Pulley and Bearing assembly should be replaced.

## 1D-6 AIR CONDITIONING COMPRESSOR OVERHAUL

2. Check bearing for brinelling, excessive looseness, noise, and lubricant leakage. If any of these conditions exist, bearing should be replaced. See "A-6 Compressor Pulley Bearing" Replacement procedure.

3. Press or tap Pulley and Bearing assembly on neck of compressor until it seats, using Pulley and Bearing Installer J 9481 with Universal Handle J 8092 (Fig. 1D-11). The Installer will apply force to inner race of bearing and prevent damage to bearing if tool is installed on handle as shown.



Fig. 1D-11 Installing A-6 Pulley and Bearing Asm.

4. Check pulley for binding or roughness. Pulley should rotate freely.

5. Install retainer ring, using Snap Ring Pliers J 6435.

6. Install absorbent sleeve retainer in neck of compressor. Using sleeve from Seal Seat Remover-Installer J 9393, install retainer so that outer edge is recessed .8mm (1/32") from compressor neck face.

7. Install Clutch Plate and Hub assembly as described in "A-6 Compressor Clutch Plate and Hub Asm." Replacement procedure.

### A-6 COMPRESSOR PULLEY BEARING

#### Remove

1. Remove Clutch Plate and Hub assembly as described in "A-6 Compressor Clutch Plate and Hub Asm." Removal procedure.

2. Remove Pulley and Bearing assembly as described in "A-6 Compressor Pulley and Bearing Asm." Removal procedure.

3. Remove pulley bearing retainer ring with a small screwdriver or pointed tool (Fig. 1D-12).

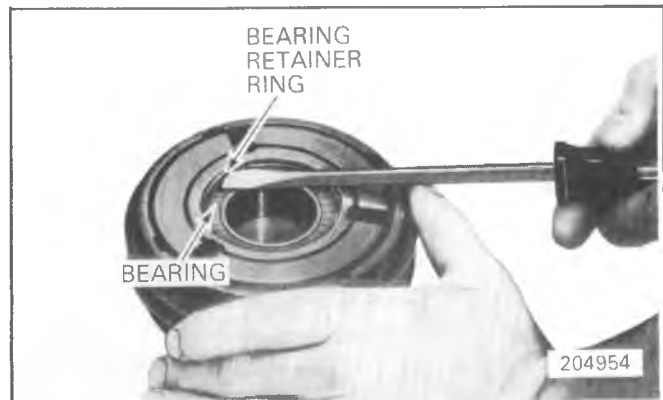

Fig. 1D-12 Removing A-6 Pulley and Bearing Retainer Ring

4. Place Pulley and Bearing assembly on inverted Support Block J 21352 and, using Pulley Bearing Remover J 9398 with Universal Handle J 8092, drive Bearing assembly out of pulley (Fig. 1D-13).

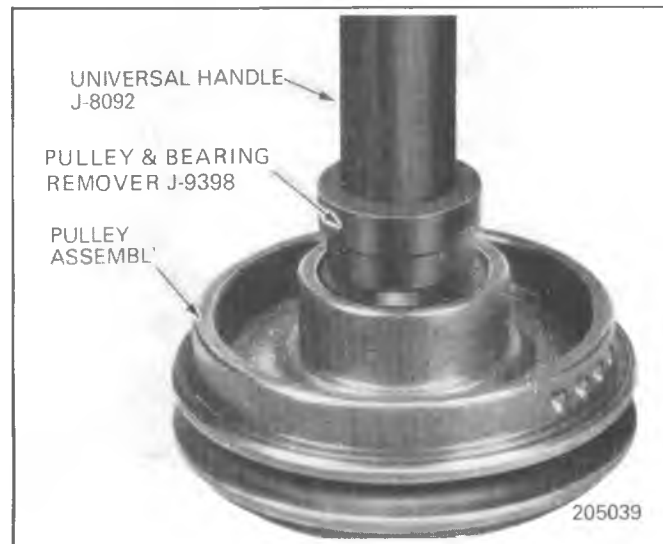

Fig. 1D-13 Removing Bearing From A-6 Pulley Asm.

#### Replace

1. Install new bearing in pulley using Pulley and Bearing Installer J 9481 with Universal Handle J 8092 (Fig. 1D-14). The Installer will apply the force to the outer race of the bearing when tool is used as shown.

**NOTICE:** Do not clean new bearing assembly with any type of solvent. Bearing is supplied with correct lubricant when assembled and requires no other lubricant at any time.

2. Install bearing retainer ring, making certain that it is properly seated in ring groove.

3. Install Pulley and Bearing assembly as described in "A-6 Compressor Pulley and Bearing Asm." Replacement procedure.

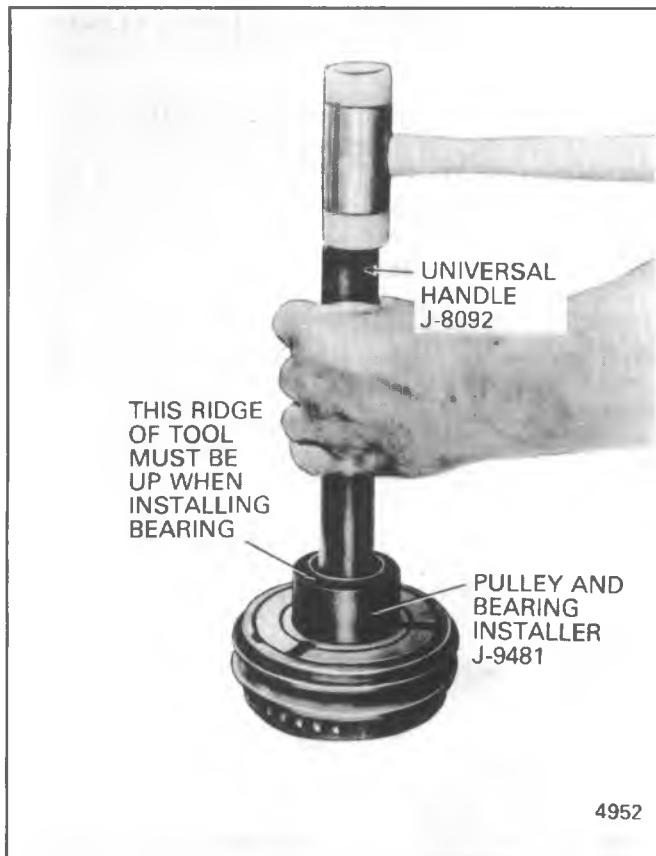

Fig. 1D-14 Installing Bearing on A-6 Pulley

4. Install Clutch Plate and Hub assembly as described in "A-6 Compressor Clutch Plate and Hub Asm." Replacement procedure.

### A-6 COMPRESSOR CLUTCH COIL AND HOUSING ASSEMBLY

#### Remove

1. Remove Clutch Plate and Hub assembly as described in "Compressor Clutch Plate and Hub Asm." Removal procedure.

2. Remove Pulley and Bearing assembly as described in "A-6 Compressor Pulley and Bearing Asm." Removal procedure. Note position of terminals on coil housing and scribe location on compressor front head casting.

3. Remove coil housing retaining ring, using Snap-Ring Pliers J 6435 (Fig. 1D-15).

4. Lift Coil and Housing assembly off compressor front head.

#### Replace

1. Position coil and housing assembly on compressor front head casting so that electrical terminals line up with marks previously scribed on compressor (Fig. 1D-16).



Fig. 1D-15 Removing A-6 Coil Housing Retainer Ring

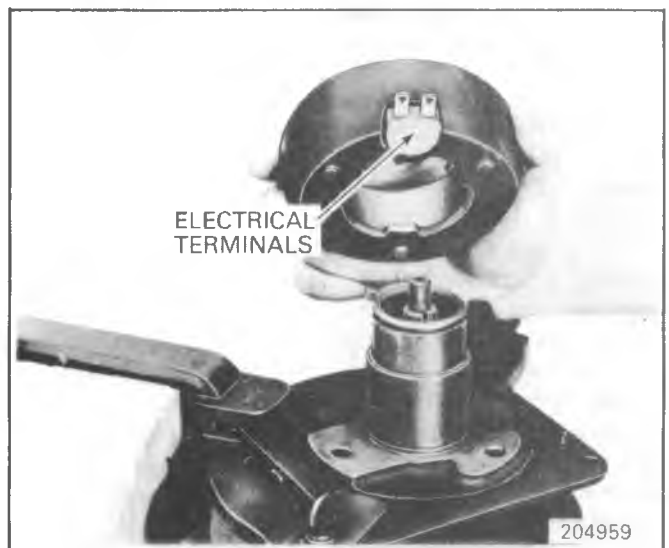

Fig. 1D-16 Installing A-6 Coil Housing

2. Align locating extrusions on coil housing with holes in front head casting.

3. Install coil housing retaining ring with flat side of ring facing coil, using Snap-Ring Pliers J 6435.

4. Install Pulley and Bearing assembly as described in "A-6 Compressor Pulley and Bearing Asm." Replacement procedure.

5. Install Clutch Plate and Hub assembly as described in "A-6 Compressor Clutch Plate and Hub Asm." Replacement procedure.

# MAJOR A-6 COMPRESSOR REPAIR PROCEDURES

Service repair procedures to the Compressor Shaft Seal, Pressure Relief Valve, or disassembly of the Internal Compressor Cylinder and Shaft Assembly are considered "MAJOR" SINCE THE REFRIGERATION SYSTEM MUST BE COMPLETELY PURGED OF REFRIGERANT before proceeding and/or because major internal operating and sealing components of the compressor are being disassembled and serviced.

Should an A-6 compressor, its compressor shaft seal, or any other component ever be removed for servicing because it was determined to be the cause of excessive signs of oil leakage in the A-6 A/C system, then the oil in the compressor must be drained, measured and replaced according to "C.C.O.T. Refrigerant Oil Distribution" in the Air Conditioning section to determine oil loss. The accumulator in this A-6 system must then also be removed - oil drained - measured, etc. according to same section.

When replacing the shaft seal assembly (Fig. 1D-17), pressure relief valve (Fig. 1D-23), even if the compressor remains on the vehicle during the operation, it will be necessary to purge the system of refrigerant as outlined in the Air Conditioning section (see "Discharging, Adding Oil, Evacuating and Charging Procedures for C.C.O.T. A/C Systems"). The same holds true for any disassembly of the internal A-6 compressor cylinder and shaft assembly.

If the A-6 Compressor Internal Cylinder and Shaft Assembly is to be serviced or replaced, then the oil in the compressor must be drained, measured and replaced according to "C.C.O.T. Refrigerant Oil Distribution" in the Air Conditioning section to determine addition of proper oil quantity to new assembly.

A clean workbench, preferably covered with a sheet of clean paper, orderliness in the work area and a place for all parts being removed and replaced is of great importance, as is the use of the proper, clean service tools. Any attempt to use make-shift or inadequate equipment may result in damage and/or improper compressor operation.

These procedures are based on the use of the proper service tools and the condition that an adequate stock of service parts is available. All parts required for servicing the internal compressor are protected by a preservation process and packaged in a manner which will eliminate the necessity of cleaning, washing or flushing of the parts. The parts can be used in the internal assembly just as they are removed from the service package.

Piston shoe discs and shaft thrust races will be identified by "number" on the parts themselves for reference to determine their size and dimension (see Fig. 1D-41).

## A-6 COMPRESSOR SHAFT SEAL

### SEAL LEAK DETECTION

A SHAFT SEAL SHOULD NOT BE CHANGED BECAUSE OF AN OIL-LINE ON THE HOOD INSULATOR. The Seal is designed to seep some oil for lubrication purposes. Only change a Shaft Seal when a leak is detected by evidence of oil sprayed in LARGE AMOUNTS and then only after actual refrigerant leakage is determined by testing with a Leak Detector J 23400.

SHOULD AN A-6 COMPRESSOR SHAFT SEAL EVER HAVE TO BE REPLACED BECAUSE IT WAS DETERMINED TO BE THE CAUSE OF EXCESSIVE SIGNS OF OIL LEAKAGE IN THE A/C SYSTEM, THEN THE OIL IN THE A-6 COMPRESSOR MUST BE DRAINED, measured and replaced according to "C.C.O.T. Refrigerant Oil Distribution" in the AIR CONDITIONING section to determine oil loss. THE ACCUMULATOR IN THIS A-6 SYSTEM MUST THEN ALSO be removed - oil drained - measured, etc. according to same section.

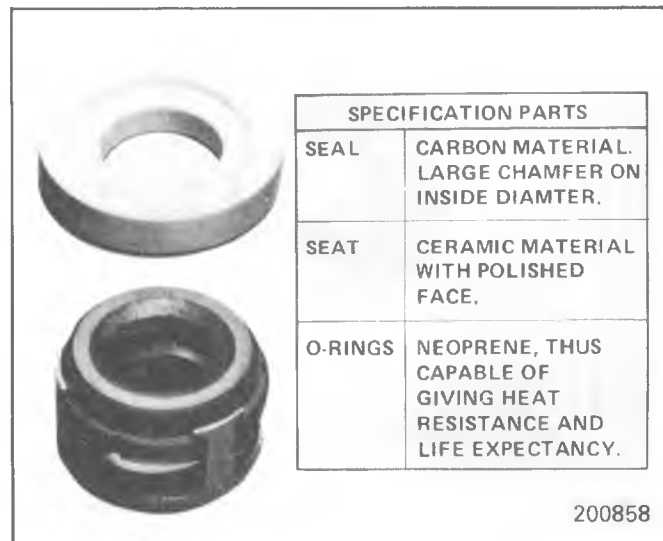

Fig. 1D-17 Specification A-6 and R-4 Compressor Shaft Seal Kit

### Remove

1. "Discharge the Refrigerant System" according to the discharging, adding oil, evacuating and charging procedures for C.C.O.T. A/C systems in the Air Conditioning section.

2. Remove the clutch plate and hub assembly and shaft key as described in "A-6 Compressor Clutch Plate and Hub Asm." removal procedure.

3. Pry out the sleeve retainer and remove the absorbent sleeve. Remove the shaft seal seat retaining ring, using Snap-Ring Pliers J 5403. See Fig. 1D-18.

4. Thoroughly clean inside of compressor neck area surrounding the shaft, the exposed portion of the seal seat and the shaft itself. This is absolutely necessary to prevent any dirt or foreign material from getting into compressor.

5. Place Seal Protector J 22974 over the end of the shaft to prevent chipping the ceramic seat. Fully engage the knurled tangs of Seal Seat Remover-Installer J 23128 into the recessed portion of the seal seat by turning the handle clockwise. Remove the Seal Seat from the compressor with a rotary-pulling motion (Fig. 1D-19). Discard the Seat.

Do not tighten the handle with a wrench or pliers; however, the handle must be hand-tightened securely to remove the Seat.

6. With Seal Protector J 22974 still over the end of the shaft, set Seal Remover-Installer J 9392 down over shaft

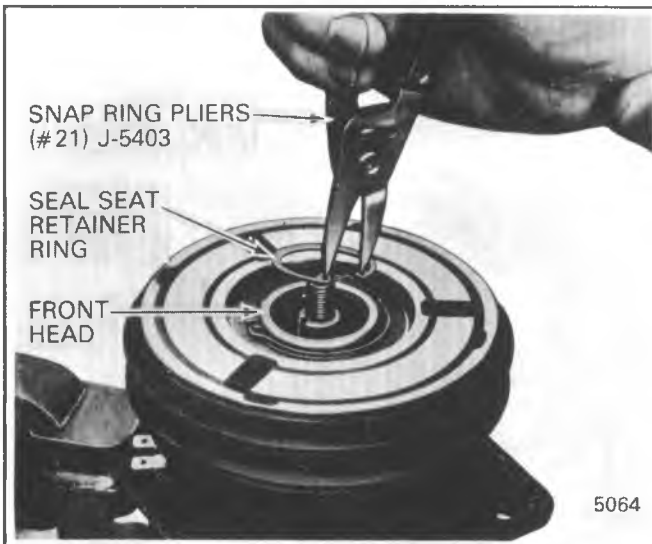

Fig. 1D-18 Removing or Installing A-6 Shaft Seal Seat Retaining Ring

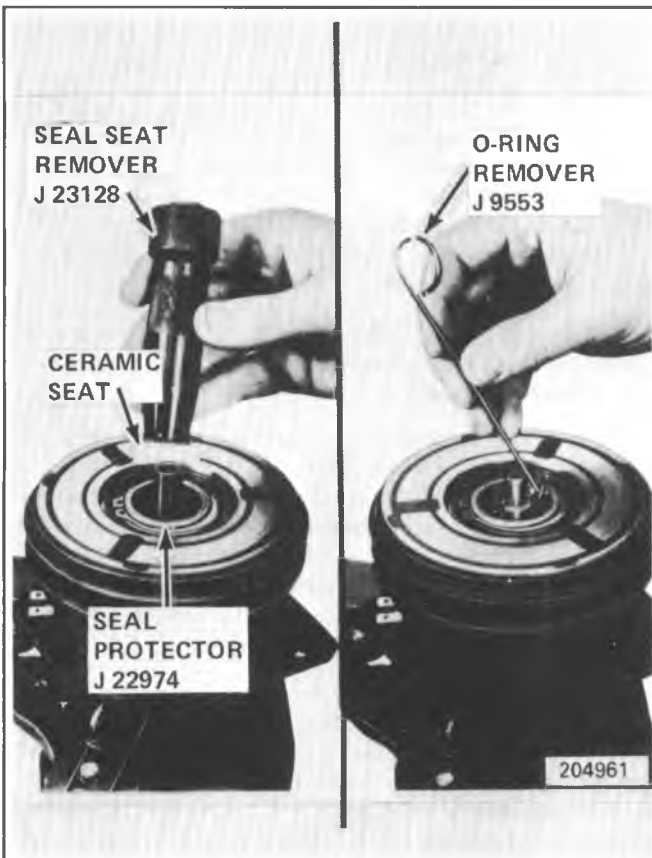

Fig. 1D-19 Removing A-6 Shaft Seal Seat and O-Ring

end, turning clockwise, while pressing down, to engage Remover tangs with the tabs on the Seal assembly. Then lift the Shaft Seal assembly out (see Fig. 1D-20). Discard the Seal.

7. Remove and discard the seal seat O-ring from the compressor neck, using O-Ring Remover J 9533 (see Fig. 1D-19).

8. Recheck the shaft and inside of the compressor neck for dirt or foreign material and be sure these areas are perfectly clean before installing new parts.



Fig. 1D-20 Replacing A-6 Seal and O-Ring

### Inspection

Seals should not be reused. Always use a new seal kit on rebuild (see Fig. 1D-17). Be extremely careful that the face of the Seal to be installed is not scratched or damaged in any way. Make sure that the Seal Seat and Seal are free of lint and dirt that could damage the seal surface or prevent sealing.

### Replace

1. Coat the new seal seat O-ring in clean 525 viscosity refrigerant oil and assemble onto O-Ring Installer J 21508 (see Fig. 1B-20).

2. Insert the O-Ring Installer J 21508 completely down into the compressor neck until the Installer "bottoms." Lower the movable slide of the O-Ring Installer to release the O-ring into the seal seat O-ring lower groove. (The compressor neck top groove is for the shaft seal seal retainer ring.) Rotate the Installer to seat the O-ring and remove Installer (See Fig. 1D-21).

3. Dip the O-ring and seal face of the new Seal assembly into clean 525 viscosity refrigerant oil. Carefully mount the Seal assembly to Seal Installer J 9392 by engaging the tabs of the Seal with the tangs of the Installer (Fig. 1D-20).

4. Place Seal Protector J 22974 (Fig. 1D-20) over end of compressor shaft and carefully slide the new Seal assembly down onto the shaft. Gently twist the Installer J 9392 CLOCK-WISE, while pushing the seal assembly down the shaft until the Seal assembly engages the flats on the shaft and is seated in place. Disengage the Installer by pressing downward and twisting counter-clockwise.

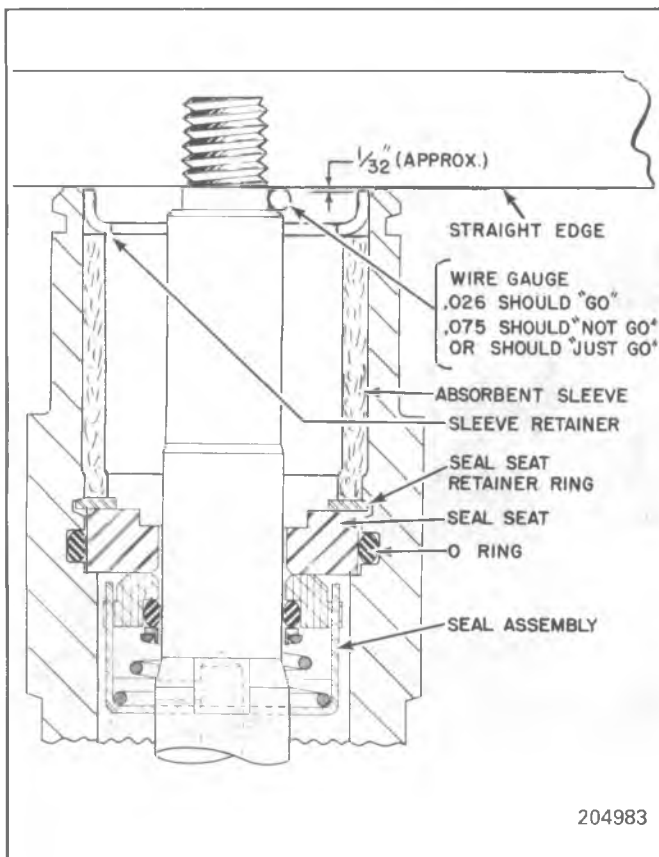

Fig. 1D-21 A-6 Compressor Shaft and Seal

5. Attach the ceramic Seal Seat to the Seal Seat Remover and Installer J 23128 and dip the ceramic Seat in clean 525 viscosity refrigerant oil to coat the seal face and outer surface. Carefully install the Seat over the compressor shaft end and Seal Protector J 22974 and push the Seat into place with a rotary motion. Take care not to dislodge the seat O-ring. However, be sure Seal Seat makes a good seal with O-ring. Remove Installer J 23128 and Seal Protector J 22974 (Fig. 1D-19).

6. Install the new seal seat retainer ring with its flat side against the Seal Seat, using Snap-Ring Pliers J 5403. See Fig. 1D-18. Use the sleeve from Seal Seat Remover-Installer J 9393 to press in on the seal seat retainer ring so that it snaps into its groove.

7. Install Compressor Leak Test Fixture J 9625 (Fig. 1D-22) on rear head of compressor and connect gage charging lines or pressurize suction side (low-pressure side) of compressor on vehicle with Refrigerant-12 vapor to equalize pressure to the drum pressure. Temporarily install the shaft nut and, with compressor in horizontal position and oil sump down, rotate the compressor shaft in normal direction of rotation several times by hand then leak test the Seal. Correct any leak found. Remove, discard and later replace the shaft nut.

8. Remove any excess oil, resulting from installing the new seal parts, from the shaft and inside the compressor neck.

9. Install the new absorbent sleeve by rolling the material into a cylinder, overlapping the ends, and then slipping the sleeve into the compressor neck with the overlap towards the top of the compressor. With a small screwdriver



Fig. 1D-22 Leak Testing A-6 Compressor

or similar instrument, carefully spread the sleeve until the ends of the sleeve butt at the top vertical centerline.

10. Position the new metal sleeve retainer so that its flange face will be against the front end of the sleeve. The sleeve from seal seat remove installer tool J 9393 may be used to install the retainer. Press and tap with a mallet, setting the retainer and sleeve into place (retainer should be recessed approximately .8mm (1/32") from the face of the compressor neck). (See Fig. 1D-21.)

11. Reinstall the Clutch Plate and Hub assembly as described in "A-6 Compressor Clutch Plate and Hub Asm." Replacement procedure.

Some compressor shaft seal leaks may be the result of mispositioning of the axial plate on the compressor shaft. The mispositioning of the axial plate may be caused by improper procedures used during pulley and driven plate removal, pounding, collisions or dropping the compressor. If the axial plate is mispositioned, the carbon face of the shaft seal assembly may not contact the seal seat and the rear thrust races and bearing may be damaged.

To check for proper positioning of the axial plate on the shaft, remove the clutch driven plate and measure the distance between the front head extension and the flat shoulder on the shaft as shown in Fig. 1D-21. To measure this distance, use a wire gage (the clearance should be between .7 and 1.9mm (.026" and .075")). If the shaft has been pushed back in the axial plate (measurement greater than 1.9mm (.075")), disassemble the compressor and replace the shaft and axial plate assembly rear thrust races and thrust bearing.

If there also appears to be too much or insufficient air gap between the drive and driven plates, dislocation of the shaft should be suspected. If the carbon seal is not seating against the seal seat, it will not be possible to completely "Evacuate the System" as outlined under discharging, adding oil, evacuating and charging procedures for C.C.O.T. A/C systems in the Air Conditioning section.

12. "Add Oil, Evacuate and Charge System" (see discharging, adding oil, evacuating and charging procedures for C.C.O.T. A/C systems in the air conditioning section).



### A-6 COMPRESSOR PRESSURE RELIEF VALVE

When necessary to replace the Pressure Relief Valve located in the compressor rear head casting (Fig. 1D-23), the valve assembly should be removed after purging the system of refrigerant. A new valve and O-ring coated with 525 viscosity refrigerant oil should be installed (see discharging, adding oil, evacuating and charging procedures for C.C.O.T. A/C systems in the air conditioning section).

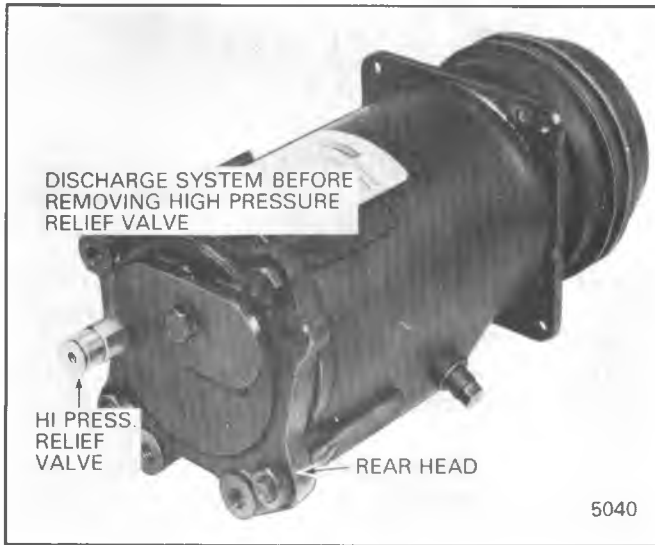

Fig. 1D-23 A-6 High Pressure Relief Valve

### A-6 COMPRESSOR INTERNAL MECHANISM (CYLINDER AND SHAFT ASM.)

Service operations to the A-6 compressor Rear Head or Internal Mechanism (Cylinder and Shaft) of the compressor should be performed with the system purged of refrigerant according to the discharging, adding oil, evacuating and charging procedures for C.C.O.T. A/C systems in the Air Conditioning section. The compressor must also be removed from the vehicle to insure that the necessary degree of cleanliness may be maintained. Additionally, "Compressor Clutch Plate and Hub, Pulley and Bearing, Clutch Coil and Housing and Shaft Seal" Removal procedures, as described earlier in the OVERHAUL section, all are to have been followed. Clean hands, clean tools and a clean bench, preferably covered with clean paper, are of extreme importance.

An inspection should be made of the Internal Mechanism (Cylinder and Shaft) assembly to determine if any service operations should be performed. A detailed inspection of parts should be made to determine if it is necessary to replace them.

#### Removal

1. Before proceeding with disassembly, wipe exterior surface of compressor clean.

2. All oil in compressor should be drained and measured. Assist draining by positioning compressor with

oil drain plug down. Record the amount of oil drained from the compressor (See "C.C.O.T. Refrigerant Oil Distribution" in the Air Conditioning section).

3. Invert compressor and Holding Fixture J 9396, with front end of compressor shaft up, suction - discharge ports now facing downward (Fig. 1D-24).

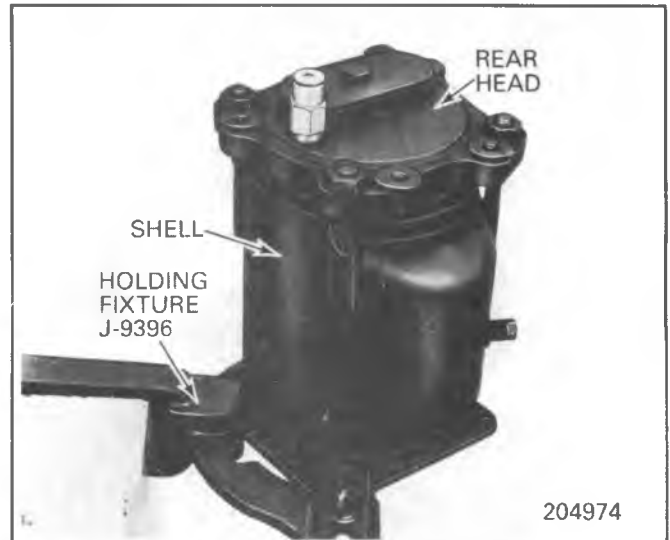

Fig. 1D-24 A-6 Compressor Installed in Holding Fixture

Additional oil may drain from the compressor at this time. All oil must be drained into a container so that total amount can be measured. (SEE STEP 2 ABOVE.) A liquid measuring cup may be used for this purpose. Drained oil should then be discarded.

4. Remove four locknuts from threaded studs on compressor shell and remove rear head. Tap uniformly around rear head if head is binding (Fig. 1D-24).

5. Wipe excess oil from all sealing surfaces on rear head casting webs, and examine sealing surfaces (Fig. 1D-25). If any damage is observed, the Rear Head should be replaced.

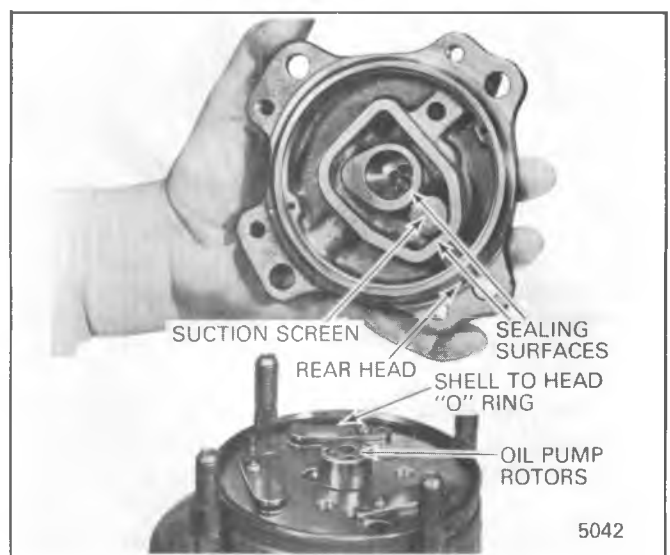

Fig. 1D-25 A-6 Rear Head Removal

6. Remove Suction Screen and examine for any damage or contamination. Clean or replace if necessary.

## 1D-12 AIR CONDITIONING COMPRESSOR OVERHAUL

7. Make an identifying mark on exposed face of inner and outer Oil Pump Gears and then remove gears. Identifying marks are to assure that gears, if re-used, will be installed in identical position.

8. Remove and discard rear head to shell O-ring.

9. Carefully remove Rear Discharge Valve Plate assembly. Use two small screwdrivers under reed retainers to pry up on assembly (Fig. 1D-26). Do not position screwdrivers between reeds and reed seats.

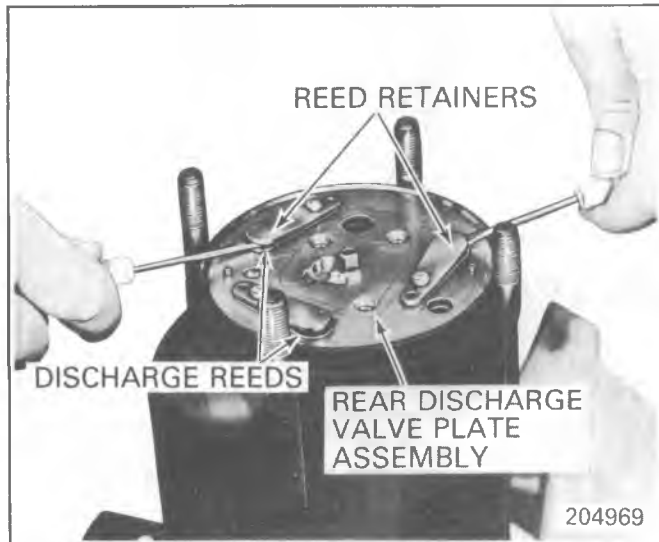

Fig. 1D-26 Removing A-6 Rear Discharge Valve Plate

10. Examine Valve Reeds and Seats. Replace entire assembly if any reeds or seats are damaged.

11. Using two small screwdrivers, carefully remove Rear Suction Reed (Fig. 1D-27). Do not pry up on horseshoe-shaped reed valves.



Fig. 1D-27 Removing A-6 Rear Suction Reed

12. Examine reeds for damage, and replace if necessary.

13. Using Oil Pick-Up Tube Remover J 5139 (Fig. 1D-28), remove Oil Pick-Up Tube. Remove O-ring from oil inlet.

14. Loosen compressor from Holding Fixture J 9396, place Internal Cylinder and Shaft Assembly Support Block J 21352 over oil pump end of shaft and, while holding Support Block in position with one hand, lift compressor from Holding Fixture with other hand. Invert compressor (shaft will now be facing upward) and position on bench with Internal Assembly Support Block resting on bench.



Fig. 1D-28 Removing A-6 Oil Pick-Up Tube

15. Lift Front Head and Compressor Shell Assembly up, leaving Internal Cylinder and Shaft Assembly resting on Internal Assembly Support Block.

**NOTICE:** To prevent damage to shaft, **DO NOT TAP ON END OF COMPRESSOR SHAFT** to remove Internal Cylinder and Shaft Assembly. If Internal Assembly will not slide out of compressor shell, tap on Front Head with a plastic hammer.

16. Rest compressor shell on its side and push Front Head assembly through Compressor Shell, being careful not to damage sealing areas on inner side of front head. Discard O-ring.

It may be necessary to tap on outside of front head, using a plastic hammer, to overcome friction of O-ring seal between front head and compressor shell.

17. Wipe excess oil from sealing surfaces on front head casting webs and examine sealing surface. If any surface damage is observed, the head should be replaced.

18. Remove Front Discharge Valve Plate assembly and Front Suction Reed Plate. Examine reeds and seats. Replace necessary parts.

19. Remove Suction Cross-Over Cover by prying with screwdriver between cylinder casting and cover (Fig. 1D-29).



Fig. 1D-29 Removing A-6 Suction Cross-Over Cover



20. Examine Internal Cylinder and Shaft Assembly for any obvious damage. If Internal Assembly has sustained major damage, due to loss of refrigerant or oil, it may be necessary to use the Service Internal Cylinder and Shaft Assembly rather than replace individual parts.

## A-6 COMPRESSOR INTERNAL CYLINDER AND SHAFT ASM

### Disassembly

Use Parts Tray J 9402 (Fig. 1D-33) to retain compressor parts during disassembly.

1. Remove Internal Cylinder and Shaft Assembly from compressor as described in "A-6 Compressor Internal Mechanism (Cylinder and Shaft Asm.)" Removal procedure.

2. Identify by pencil mark, or some other suitable means, each piston numbering them as 1, 2 and 3 (Fig. 1D-30).

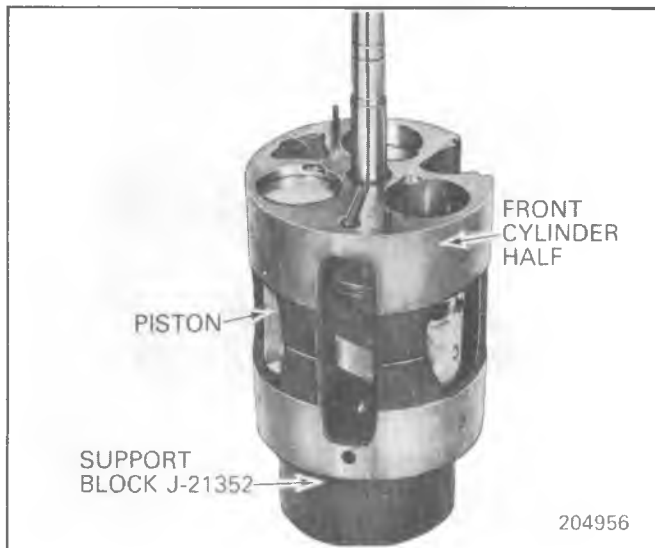

Fig. 1D-30 Numbering A-6 Piston and Cylinder Bores

Number the piston bores in the front cylinder half in like manner, so that pistons can be replaced in their original locations.

3. Separate cylinder halves, using a wood block and mallet (Fig. 1D-31). Make certain that discharge cross-over tube does not contact axial plate when separating cylinder halves (a new Service Discharge Cross-Over Tube will be installed later - see Step 5 of Internal Cylinder and Shaft Assembly procedure).

**NOTICE:** UNDER NO CIRCUMSTANCES SHOULD SHAFT BE STRUCK AT EITHER END in an effort to separate upper and lower cylinder halves because the shaft and the axial plate could be damaged.

4. Carefully remove the Rear Half of the cylinder from the pistons and set the Front Cylinder Half, with the piston, shaft and axial plate in Compressing Fixture J 9397.

5. Pull up on compressor shaft and remove piston previously identified as No. 1, with balls and shoe discs, from axial plate.



Fig. 1D-31 Separating A-6 Cylinder Halves

a. Inspect the Teflon piston rings for nicks, cuts or metal particles imbedded in exposed ring surface and replace the piston rings as required if either condition exists. See "A-6 Teflon Piston Ring" Replacement procedure.

6. Remove and discard the piston shoe discs.

7. Remove and examine piston balls, and if satisfactory for re-use, place balls in No. 1 compartment of Parts Tray J 9402 (Fig. 1D-33).

8. Place piston in No. 1 compartment of Parts Tray J 9402, with notch in casting web at front end of piston (Fig. 1D-32) into the dimpled groove of Parts Tray compartment.

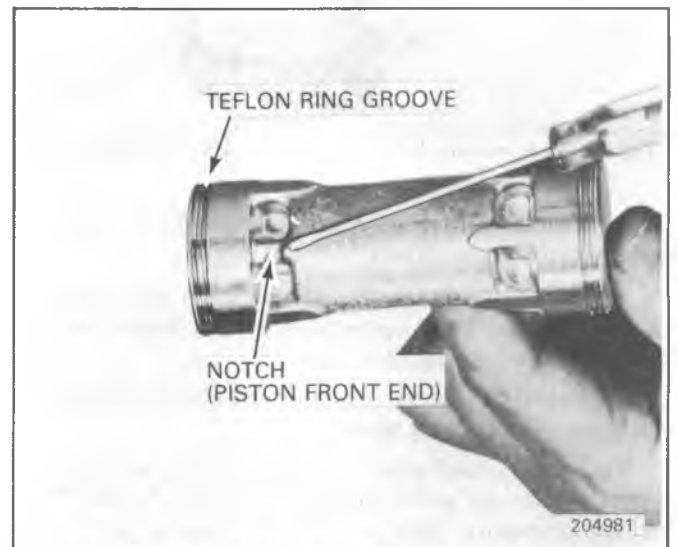

Fig. 1D-32 Notch Identifying Front End of A-6 Piston

9. Repeat Steps 5 through 9 for Pistons No. 2 and No. 3.

10. Remove rear combination of thrust races and thrust bearing from shaft. Discard races and bearing.

11. Remove shaft assembly from front cylinder half. If the Discharge Cross-Over Tube remained in the front cylinder half, it may be necessary to bend discharge cross-over tube slightly in order to remove shaft.

## 1D-14 AIR CONDITIONING COMPRESSOR OVERHAUL

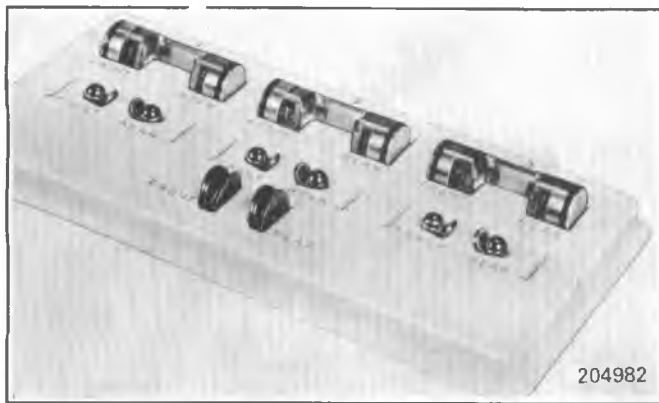

Fig. 1D-33 A-6 Parts Tray

12. Remove front combination of thrust races and bearing from shaft. Discard races and bearing (Fig. 1D-34).

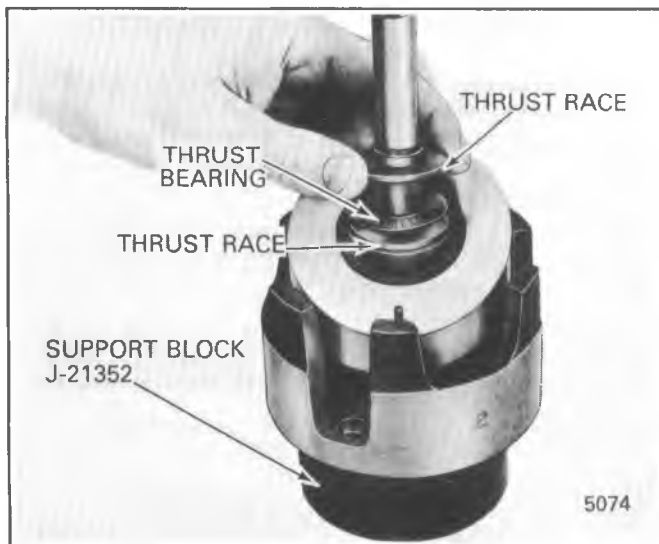

Fig. 1D-34 Removing A-6 Front Thrust Races and Bearings

13. Examine surface of Axial Plate and Shaft. Replace as an assembly, if necessary.

A certain amount of shoe disc wear on axial plate is normal, as well as some markings indicating load of needle bearings on shaft.

14. Remove Discharge Cross-Over Tube from cylinder half, using self-clamping pliers.

This is necessary only on original factory equipment, as ends of the tube are swaged into cylinder halves. The discharge cross-over tube in Internal Cylinder and Shaft Assemblies that have been previously serviced have an O-ring and bushing at each end of the tube, and can be easily removed by hand (see Fig. 1D-53).

15. Examine piston bores and needle bearings in front and rear cylinder halves. Replace front and rear cylinders if any cylinder bore is deeply scored or damaged.

16. Needle bearings may be removed if necessary by driving them out with special Thin-Wall Socket J 9399. Insert socket in hub end (inner side) of cylinder head and drive bearing out.

To install needle bearing, place cylinder half on Support Block J 21352, and insert bearing in end of cylinder head

with bearing identification marks up. Use Needle Bearing Installer J 9432 and drive bearing into cylinder head (Fig. 1D-35 until Installer "bottoms" on the cylinder face.

Two different width needle bearings are used in Production compressors - a 13mm (1/2") size and a 16mm (5/8") size. The bearings are interchangeable. Service replacement bearings are all 12.7mm (1/2").

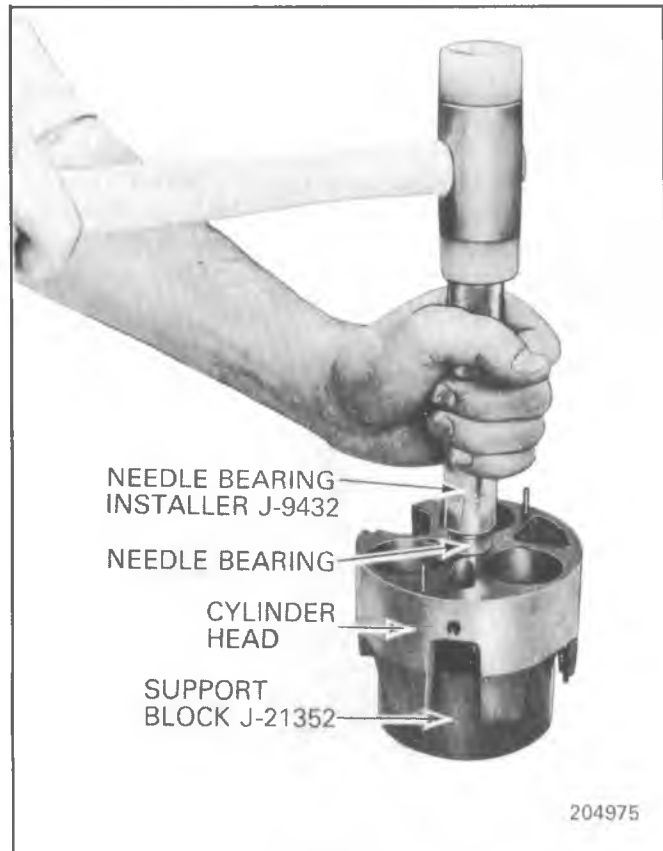

Fig. 1D-35 Installing A-6 Needle Bearing

17. Wash all parts to be re-used with trichloroethane, naphtha, stoddard solvent, kerosene, or a similar solvent. Air-dry parts using a source of clean, dry air.

A-6 compressor internal components may be identified by referring to Fig. 1D-2.

### A-6 COMPRESSOR INTERNAL CYLINDER AND SHAFT ASM

#### Gaging Operation

1. Install Compressing Fixture J 9397 on Holding Fixture J 9396 in vise. Place front cylinder half in Compressing Fixture, flat side down. Front cylinder half has long slot extending out from shaft hole. "Legs" of front cylinder half will be pointed upward.

2. Secure from Service parts stock four zero thrust races, two thrust bearings and three zero shoe discs.

3. Now install a zero thrust race, then one thrust bearing, and a second zero thrust race onto front end of compressor shaft.

4. Insert threaded end of axial shaft through needle bearing in front cylinder half, and allow thrust race and bearing assembly (race-bearing-race) to rest on hub of cylinder.

5. Now install a zero thrust race on rear end of compressor axial shaft (Fig. 1D-36), so that it rests on hub of axial plate. Then add one thrust bearing and a second zero thrust race onto shaft.

At this point, both front end and rear end of axial shaft will have a stack-up of one zero race-one bearing-one zero race.

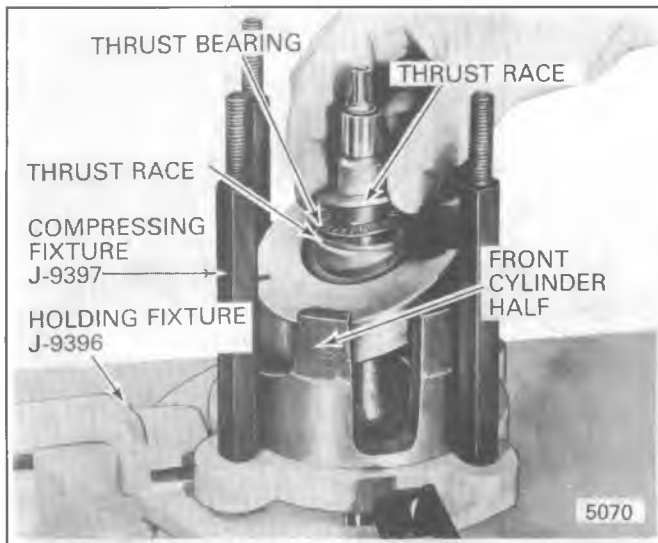

Fig. 1D-36 Installing A-6 Rear Thrust Races and Bearings

6. Lubricate ball pockets of the No. 1 Piston with 525 viscosity refrigerant oil and place a ball in each socket. Use balls previously removed if they were considered acceptable for re-use.

7. Lubricate cavity of a zero shoe disc with 525 viscosity refrigerant oil and place shoe disc over ball in front end of piston (Fig. 1D-37). Front end of piston has an identifying notch in casting web (Fig. 1D-32).

**NOTICE:** Exercise care in handling the Piston and Ring Assembly, particularly during assembly into and removal from the cylinder bores to prevent damage to the Teflon piston rings.

Shoe discs should not be installed on rear of piston during following "Gaging" operation.

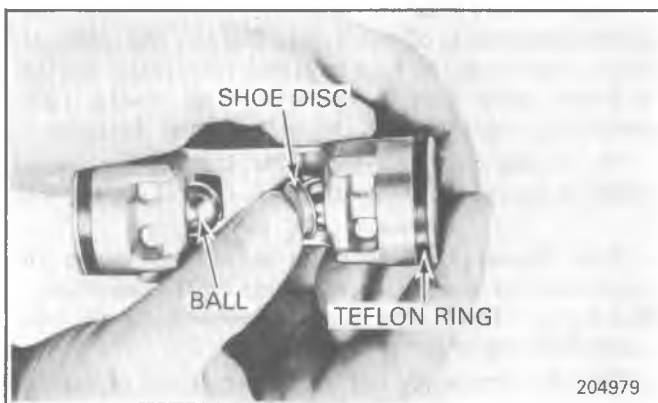

Fig. 1D-37 Installing A-6 Front Shoe Disc

8. Rotate shaft and axial plate until high point of axial plate is over the No. 1 Piston cylinder bore.

9. Lift the axial shaft assembly up a little out of front cylinder half and hold front thrust race and bearing assembly ("zero" race-bearing-"zero" race) against axial plate hub.

10. Position No. 1 Piston over No. 1 cylinder bore (notched end of piston being on bottom and piston straddling axial plate) and lower the shaft to allow No. 1 Piston to drop into its bore (Fig. 1D-38). If ball and shoe will not remain in front socket of piston during assembly use a light smear of petrolatum on the piston and shoe ball socket surfaces.

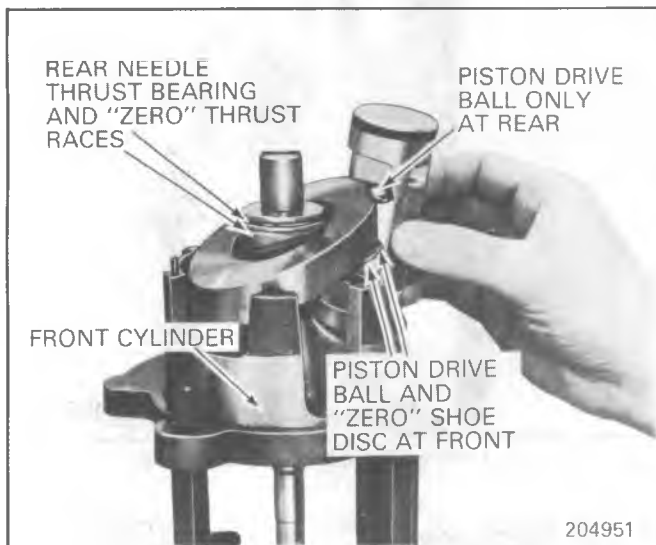

Fig. 1D-38 Installing A-6 Piston During Gaging Operation

11. Repeat Steps 6 through 10 for Pistons No. 2 and No. 3.

12. Now install rear cylinder half onto pistons, aligning cylinder with discharge cross-over tube hole in front cylinder half.

Tap into place using a plastic mallet or piece of clean wood and hammer (Fig. 1D-39).

13. Position discharge cross-over tube opening between a pair of Compressing Fixture J 9397 bolts to permit access for feeler gage.

14. Install top plate on Compressing Fixture J 9397. Tighten nuts to 20 N·m (15 lb. ft.) torque using a 0-60 N·m (0-25 lb.ft.) torque wrench.

### Gaging Procedure (Steps 15 thru 18)

The gaging operations which follow have been worked out on a simple basis to establish and provide necessary running tolerances. Two gaging procedures are necessary.

The first is made to choose the proper size shoe discs to provide, at each piston, a .04 to .06mm (.0016" to .0024") total preload between the seats and the axial plate at the tightest place through the 360-degree rotation of the axial plate. The bronze shoe discs are provided in .01mm (.0005") variations, including a basic ZERO shoe.

The second, performed at the rear shaft thrust race and bearing stack-up, is designed to obtain .06 to .08mm (.0025" to .0030") preload between the hub surfaces of the axial plate and the front and rear hubs of the cylinder. A total



Fig. 1D-39 Assembling A-6 Cylinder Halves

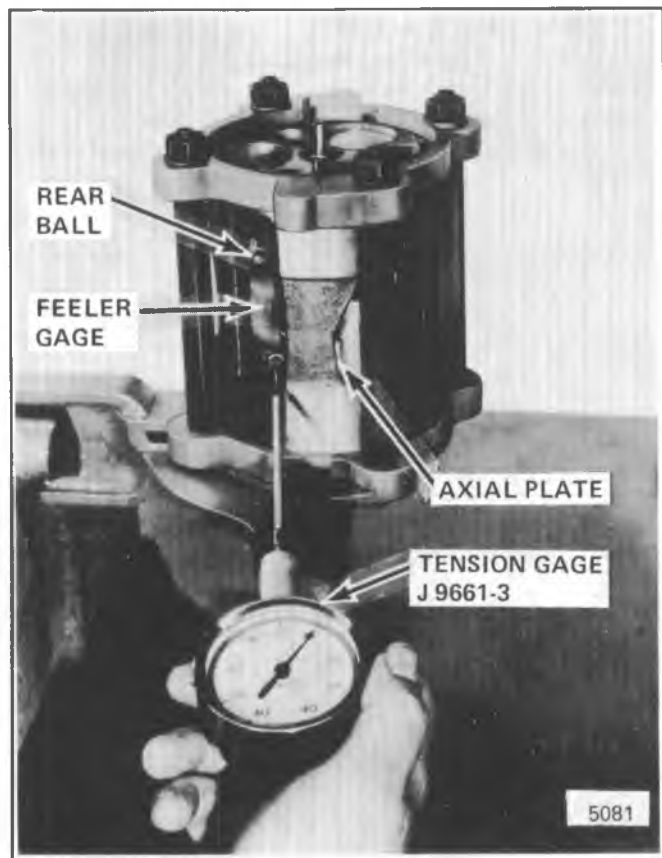

Fig. 1D-40 Gaging A-6 Rear Piston Ball

of 14 steel thrust races, including a basic ZERO race, are provided in increments of .01mm (.0005") thickness to provide the required fit.

Feeler and Tension Gage Set J 9564-01 or J 9661-01 may be used for gaging proper shoe disc size. Feeler Gage Set J 9564-01 or Dial Indicator Set J 8001 may be used to determine proper thrust race size.

Proper selection of thrust races and ball seats is of extreme importance.

15. Measure clearance between rear ball of No. 1 Piston and axial plate, in following manner:

a. Select a suitable combination of well-oiled Feeler Gage leaves to fit snugly between ball and axial plate.

b. Attach Tension Gage J 9661-3 to the feeler gage. A distributor point checking scale or Spring Scale J 544 may be used.

c. Pull on Spring Scale to slide Feeler Gage stock out from between ball and axial plate, and note reading on Spring Scale as Feeler Gage is removed (Fig. 1D-40). Reading should be between 4 and 8 ounces.

d. If reading in Step "c" above is under 4 OR over 8 ounces, reduce or increase thickness of Feeler Gage leaves and repeat Steps a. through c. above until a reading of 4 to 8 ounces is obtained. Record the clearance between ball and axial plate that results in the desired 4 to 8 ounce pull on Spring Scale.

16. Now rotate shaft 120° and repeat Step 15 between this same No. 1 Piston Rear Ball and axial plate. Record this measurement.

If shaft is hard to rotate, install shaft nut onto shaft and turn shaft with wrench.

17. Rotate shaft another 120° and again repeat Step 15 between these same parts and record measurements.

18. Select a "numbered" shoe disc corresponding to minimum feeler gage reading recorded in the three checks just made above. (See example in Fig. 1D-42). Place the selected shoe discs in Parts Tray J 9402 compartment corresponding to Piston No. 1 and Rear Ball pocket position.

Shoe discs are provided in .01mm (.0005") (one-half thousandths) variations. There are a total of 11 sizes available for field servicing. All shoe discs are marked with the shoe size, which corresponds to the last three digits of the piece part number. (See Shoe Disc Size Chart in Fig. 1D-41.)

Once a proper selection of the shoe has been made, the matched combination of shoe disc to rear ball and spherical cavity in piston must be kept in proper relationship during disassembly after Gaging operation, and during final assembly into the Internal Cylinder and Shaft Assembly.

19. Repeat in detail the same Gaging Procedure outlined in Steps 15 through 18 for Piston No. 2 and No. 3.

20A. Mount Dial Indicator J 8001 on edge of Compressing Fixture J 9397 with Clamp J 8001-1 and Sleeve J 8001-2 (Fig. 1D-43). Position Dial Indicator on rear end of axial shaft and adjust to "zero."

From bottom, apply full hand-force at end of shaft a few times before reading clearance. This will help squeeze the oil out from/between mating parts. Now push upward again and record measurement. Dial Indicator increments are .03mm (.001"); therefore, reading must be estimated to nearest .01mm (.0005").

| SHOE DISC          |                      |                          | THRUST BEARING RACE |                      |                        |
|--------------------|----------------------|--------------------------|---------------------|----------------------|------------------------|
| PART NO. ENDING IN | IDENTIFICATION STAMP | MIN. FEELER GAGE READING | PART NO. ENDING IN  | IDENTIFICATION STAMP | DIAL INDICATOR READING |
| 000                | 0                    | .0000                    | 000                 | 0                    | .0000                  |
| 175                | 17-1/2               | .0175                    | 050                 | 5                    | .0050                  |
| 180                | 18                   | .0180                    | 055                 | 5-1/2                | .0055                  |
| 185                | 18-1/2               | .0185                    | 060                 | 6                    | .0060                  |
| 190                | 19                   | .0190                    | 065                 | 6-1/2                | .0065                  |
| 195                | 19-1/2               | .0195                    | 070                 | 7                    | .0070                  |
| 200                | 20                   | .0200                    | 075                 | 7-1/2                | .0075                  |
| 205                | 20-1/2               | .0205                    | 080                 | 8                    | .0080                  |
| 210                | 21                   | .0210                    | 085                 | 8-1/2                | .0085                  |
| 215                | 21-1/2               | .0215                    | 090                 | 9                    | .0090                  |
| 220                | 22                   | .0220                    | 095                 | 9-1/2                | .0095                  |
|                    |                      |                          | 100                 | 10                   | .0100                  |
|                    |                      |                          | 105                 | 10-1/2               | .0105                  |
|                    |                      |                          | 110                 | 11                   | .0110                  |
|                    |                      |                          | 115                 | 11-1/2               | .0115                  |
|                    |                      |                          | 120                 | 12                   | .0120                  |

200913

Fig. 1D-41 Available A-6 Service Shoes and Thrust Races

|              | POSITION 1 | POSITION 2 | POSITION 3 | SELECT AND USE SHOE NO. |
|--------------|------------|------------|------------|-------------------------|
| PISTON NO. 1 | .019"      | .0195"     | .019"      | 19                      |
| PISTON NO. 2 | .020"      | .020"      | .020"      | 20                      |
| PISTON NO. 3 | .021"      | .021"      | .022"      | 21                      |

200914

Fig. 1D-42 Selection of Proper A-6 Shoe Disc

20B. An alternate method of selecting a proper race is to use Gage Set J 9661-01 selecting a suitable feeler gage leaf until the result is a 4 to 8 ounce pull on the scale between the rear thrust bearing and upper (which also happens to be the outer rear) thrust race (Fig. 1D-44). If the pull is just less than 4 ounces, add .01mm (.0005") to the thickness of the feeler stock used to measure the clearance. If the pull on the scale reads just over 8 ounces, then subtract .01mm (.0005") from the thickness of the feeler stock.

21. For either method used, select a thrust race with a "number" corresponding to two (2) full sizes larger than Dial Indicator or Feeler Gage measurement of the amount of end play shown. (If measurement is .17mm (.007"), select a No.9 or 090 race.)

Place thrust race in right-hand slot at bottom center of parts tray J 9402.

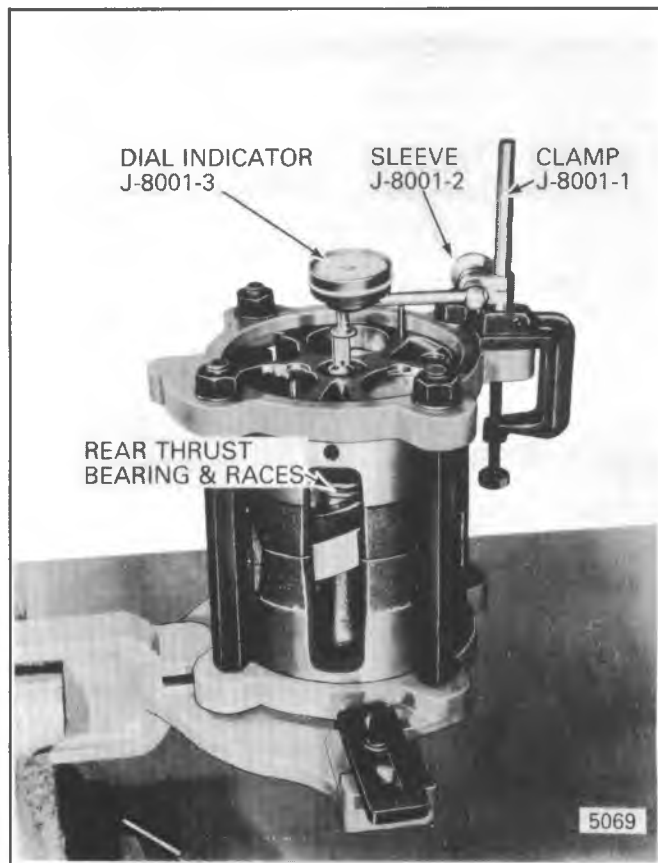

Fig. 1D-43 Gaging A-6 Rear Thrust Race

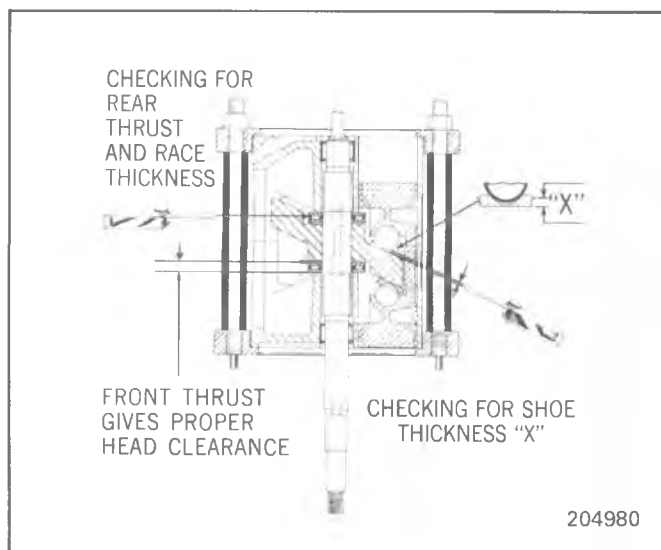

Fig. 1D-44 Checking A-6 Piston and Shaft End Play

Fifteen (15) thrust races are provided in increments of .01mm (.0005") (one-half thousandths) thickness and one ZERO gage thickness, providing a total of 16 sizes available for field service. The thrust race "number" also corresponds to the last three digits of the piece part number. See Thrust Race Size Chart in Fig. 1D-41.

22. Remove nuts from top plate of Compressing Fixture J 9397, and remove top plate.

23. Separate cylinder halves while unit is in Fixture. It may be necessary to use a wooden block and mallet.

24. Remove Rear Cylinder Half and carefully remove one piston at a time from axial plate and front cylinder half. Do not lose the relationship of the front ball and shoe disc and rear ball. Transfer each piston, ball and shoe disc to its proper place in Parts Tray J 9402.

25. Now remove rear outer zero thrust race (it will be on top) from shaft and install the thrust race just selected in Steps 20 and 21 that is presently setting in the right-hand slot at bottom center of Parts Tray J 9402.

The removed zero thrust race may be put aside for re-use in additional Gaging or rebuilding operations.

## A-6 COMPRESSOR CYLINDER AND SHAFT ASSEMBLY

### A-6 Teflon Piston Ring Replacement

The Teflon piston ring installing, sizing and gaging tools are shown in Fig. 1D-45.

1. Remove the old piston rings by carefully slicing through the ring with a knife or sharp instrument, holding the blade almost flat with the piston surface. Be careful not to damage the aluminum piston or piston groove in cutting to remove the ring. Exercise personal care in cutting the piston ring for removal to prevent injury.

2. Clean the piston and piston ring grooves with trichloroethane, naphtha, stoddard solvent, kerosene or equivalent solvent and blow the piston dry with DRY air.

3. Set the piston on-end on a clean, flat surface and install the Ring Installer Guide J 24608-2 on the end of the piston (Fig. 1D-46).

4. Install a Teflon ring on the Ring Installer Guide J 24605-2 as shown in Fig. 1D-47, with the dished or dull-side down and glossy-side up.

5. Push the Ring Installer J 24608-5 down over the Installer Guide J 24608-2 to install the Teflon ring in the piston ring groove (Fig. 1D-47). If the Teflon ring is slightly off position in the ring groove, it can be positioned into place by fingernail or blunt-edged tool that will not damage the piston.

The Ring Installer J 24608-5 will retain the Installer Guide J 24608-2 internally when the Teflon ring is installed on the piston. Remove the Installer Guide from the Ring Installer and do not store the installer guide in the ring installer, as the Ring Installer Segment Retainer O-Ring J 24608-3 will be stretched and possibly weakened during storage. This could result in the O-Ring J 24608-3 not holding the Ring Installer segments tight enough to the Installer Guide J 24608-2 to properly install the Teflon ring on the piston.

6. Lubricate the piston ring area with 525 viscosity refrigerant oil and rotate the Piston and Ring Assembly into the Ring Sizer J 24608-6 at a slight angle (Fig. 1D-48). Rotate the piston, while pushing inward, until the piston is inserted against the center stop of the Ring Sizer J 23608-6.

**NOTICE:** DO NOT push the Piston and Ring Assembly into the Ring Sizer J 24608-6 without proper positioning and rotating as described above, as the ends of the needle bearings of the Ring Sizer may damage the end of the piston.

7. Rotate the Piston and Ring Assembly in the Ring Sizer J 24608-6 several complete turns, until the Assembly rotates relatively free in the Ring Sizer (Fig. 1D-48).

8. Remove the Piston and Ring Assembly, wipe the end of the piston and ring area with a clean cloth and then push the Piston and Ring Assembly into the Ring Gage J 24608-1 (Fig. 1D-49). The piston should go through the Ring Gage with a 2 to 8 lb. force or less without lubrication. If not, repeat Steps 6 and 7.

9. Repeat the procedure for the opposite end of the piston (Fig. 1D-50).

**NOTICE:** DO NOT lay the piston down on a dirty surface where dirt or metal chips might come into contact and become imbedded in the Teflon ring surface.

10. Lubricate both ends of the piston with 525 viscosity refrigerant oil before inserting the piston into the cylinder bore.

**NOTICE:** Reasonable care should be exercised in installing the piston into the cylinder bore to prevent damage to the Teflon ring.

## A-6 COMPRESSOR INTERNAL CYLINDER AND SHAFT ASM.

### Assembly

After properly performing the "Gaging Procedure," choosing the correct shoe discs and thrust races, and





Fig. 1D-45 A-6 Teflon Piston Ring Installing, Sizing and Gaging Tools

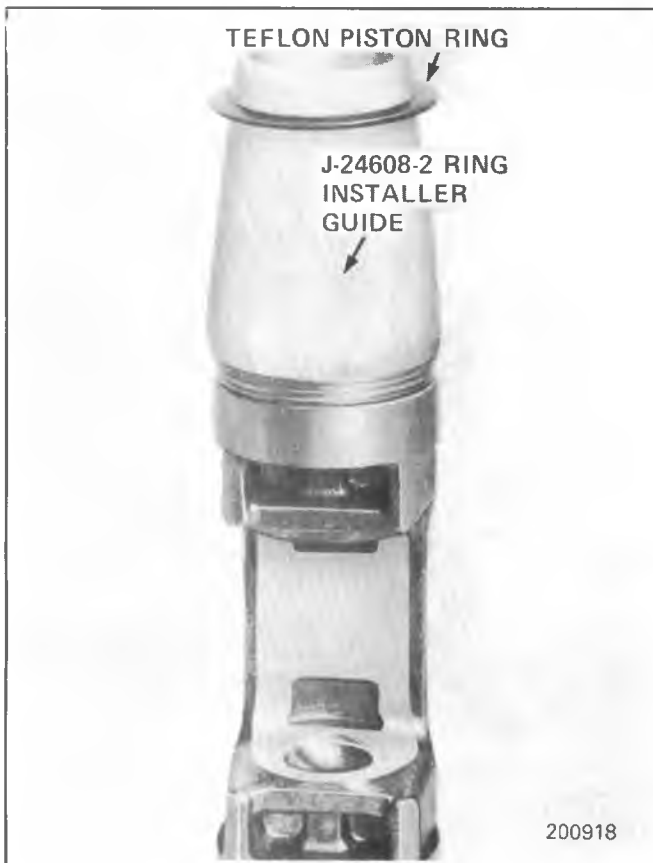

Fig. 1D-46 A-6 Teflon Piston Ring Positioned on Ring Installer Guide



Fig. 1D-47 Installing A-6 Teflon Piston Ring

installing any needed Teflon piston rings, the cylinder assembly may now be reassembled. Be sure to install all new seals and O-rings. All are included in the compressor O-Ring Service Kit.

Assembly procedure is as follows:

1. Support the front half of the cylinder assembly on Compressing Fixture J 9397. Install the shaft and axial plate, threaded end down, with its front bearing race pack (ZERO race-bearing-ZERO race), if this was not already done at the end of the "Gaging Procedure." Install rear bearing race pack (ZERO race-bearing-NUMBERED race).

2. Apply a light smear of petroleum jelly to the shoe discs and piston ball sockets and install all balls and shoe discs in their proper place in the piston assembly.

3. Rotate the axial plate so that the high point is above cylinder bore No. 1.

- a. Carefully assemble Piston No. 1, complete with ball and "zero" shoe disc on the front and ball and "numbered" shoe disc on the rear, over the axial plate.

- b. Hold front thrust bearing pack tightly against axial plate hub while lifting shaft and axial plate to install piston asm.

## 1D-20 AIR CONDITIONING COMPRESSOR OVERHAUL

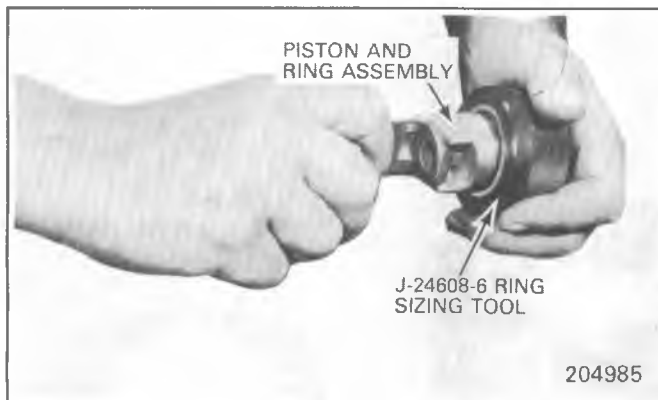

Fig. 1D-48 Turning A-6 Piston and Ring Asm. Into Ring Sizing Tool

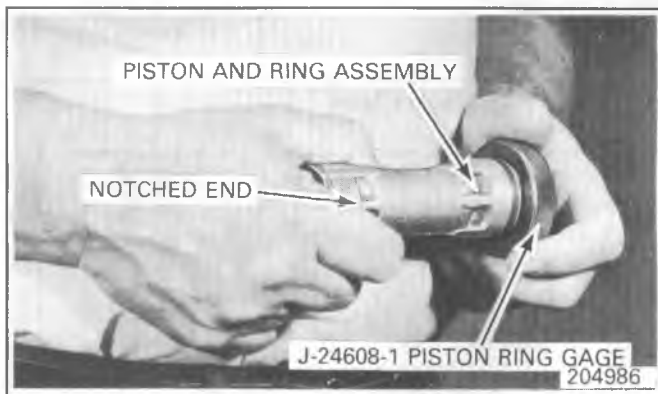

Fig. 1D-49 Gaging A-6 Piston Ring Size

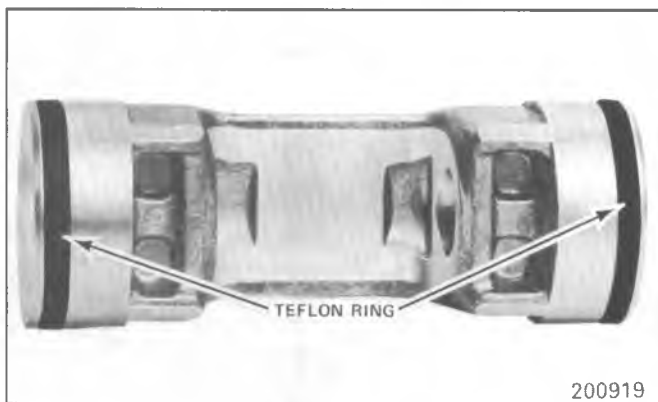

Fig. 1D-50 A-6 Teflon Piston Ring Installed in Piston Groove

c. Insert the Piston Assembly into the Front Cylinder Half (Fig. 1D-51).

4. Repeat this operation for Pistons No. 2 and No. 3 (Fig. 1D-52).

5. Without installing any O-rings or bushings, assemble one end of the new Service Discharge Cross-Over Tube into the hole in the front cylinder half (Figs. 1D-53 and 1D-54).

Be sure the flattened portion of this tube faces the inside of the compressor to allow for axial plate clearance (Fig. 1D-54).

6. Now rotate the shaft to position the pistons in a stair-step arrangement; then carefully place the Rear Cylinder Half over the shaft and start the pistons into the cylinder bore (Fig. 1D-55).

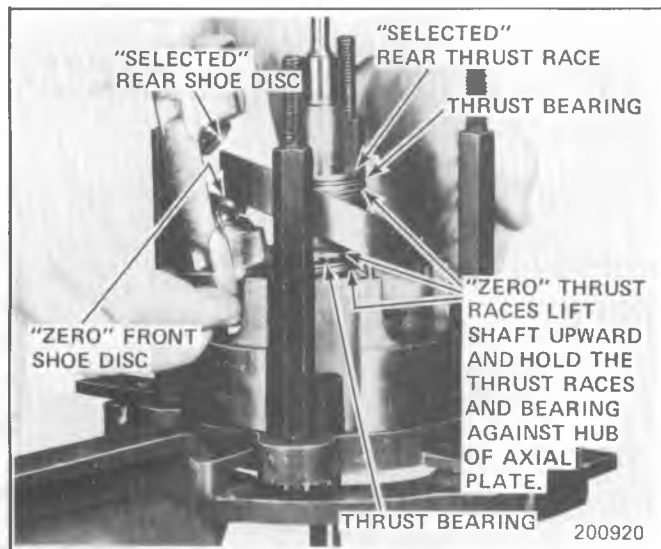

Fig. 1D-51 Installing 1st A-6 Piston Assembly Into Front Cylinder Half

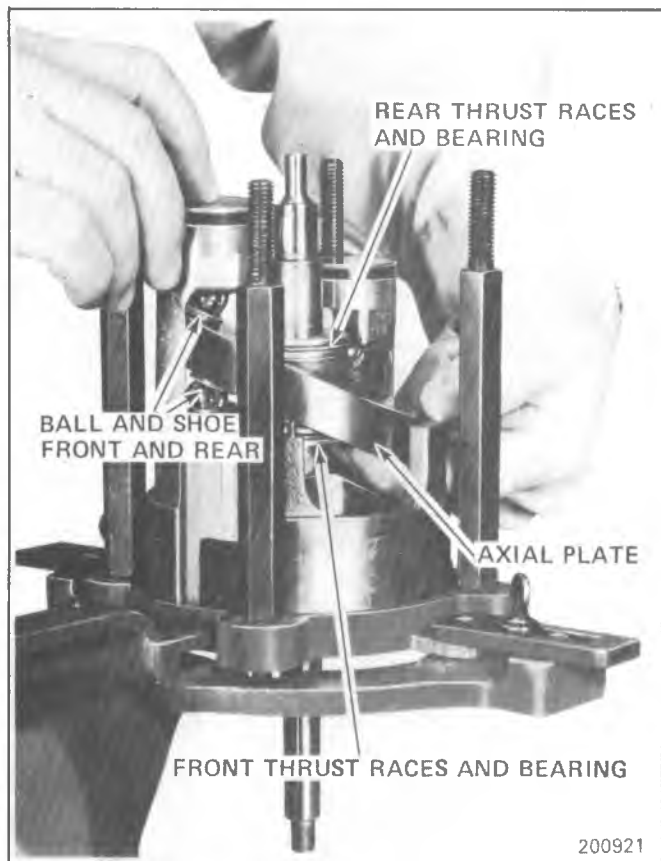

Fig. 1D-52 Installing 2nd A-6 Piston

7. When all three Piston and Ring assemblies are in their respective cylinders, align the end of the discharge cross-over tube with the hole in the rear half of the cylinder.

8. When all parts are in proper alignment, tap with a clean wooden block and mallet to seat the rear half of the cylinder over the locating dowel pins. If necessary, clamp the cylinder in Compressing Fixture J 9397, to complete drawing the cylinder halves together.

9. Generously lubricate all moving parts with clean 525 viscosity refrigerant oil and check for free rotation of the parts.



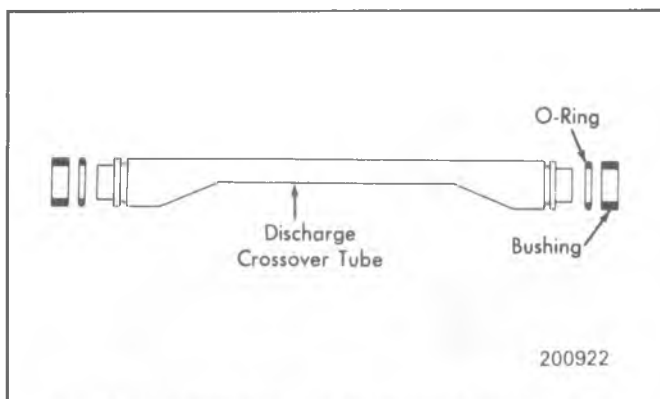

Fig. 1D-53 Service-type A-6 Discharge Cross-Over Tube

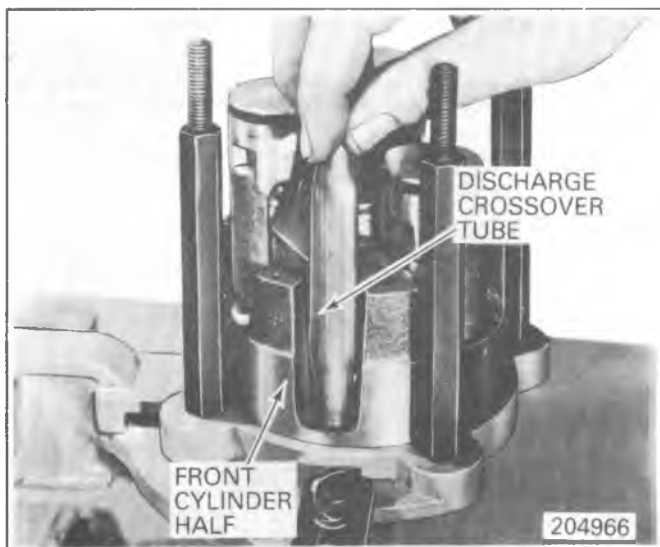

Fig. 1D-54 Installing A-6 Discharge Cross-over Tube

10. Replace the Suction Cross-Over Cover (Fig. 1D-56). Compress the cover as shown to start it into the slot, and then press or carefully tap it in until flush on both ends.

## A-6 COMPRESSOR INTERNAL CYLINDER AND SHAFT ASM

### Re-Install

1. Place Internal Cylinder and Shaft Assembly on Internal Assembly Support Block J 21352, with rear-end of shaft in Support Block hole.

2. Now install new O-ring and bushing in front-end of discharge cross-over tube (Fig. 1D-57). The O-ring and bushing are Service parts only for Internal Cylinder and Shaft Assemblies that have been disassembled in the field (Also see Fig. 1D-53).

3. Install new dowel pins in front cylinder half, if previously removed.

4. Install Front Suction Reed Plate on front cylinder half. Align with dowel pins, suction ports, oil return slot, and discharge cross-over tube (Fig. 1D-58).

5. Install Front Discharge Valve Plate assembly (it has a large diameter hole in the center), aligning holes with dowel pins and proper openings in front suction reed plate (Fig. 1D-59 and Fig. 1D-60.)

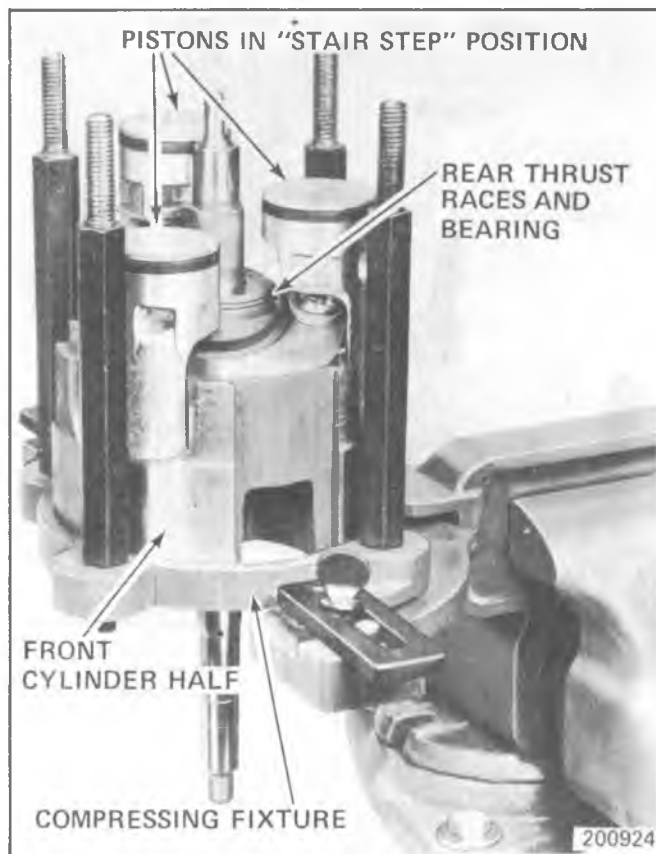

Fig. 1D-55 A-6 Pistons Positioned in Stair-Step Arrangement

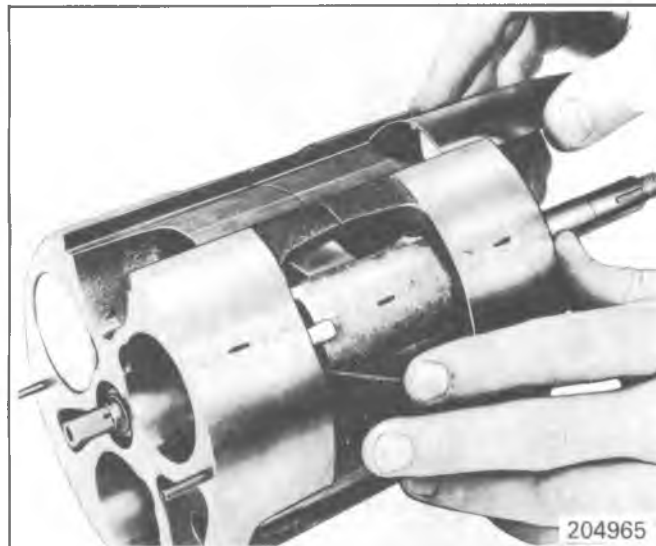

Fig. 1D-56 Installing A-6 Suction Cross-over Cover

6. Coat sealing surfaces on webs of compressor front head casting with clean 525 viscosity refrigerant oil.

7. Determine exact position of Front Head casting in relation to dowel pins on Internal Cylinder and Shaft Assembly. Mark position of dowel pins on sides of Front Head assembly and on sides of Internal Cylinder and Shaft Assembly with a grease pencil. Carefully lower Front Head casting into position (Fig. 1D-61), making certain that sealing area around center bore of head assembly does not contact shaft as head assembly is lowered. Do not rotate head assembly to line up with dowel pins, as the sealing areas would then contact the reed retainers.

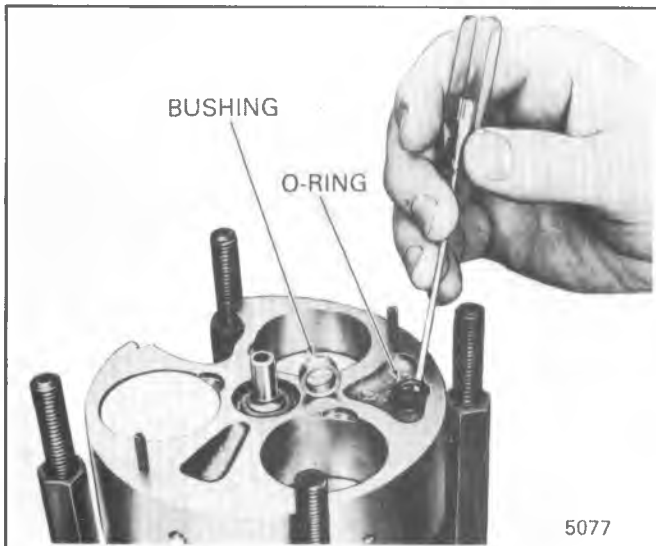

Fig. 1D-57 Installing O-Ring On A-6 Discharge Cross-Over Tube

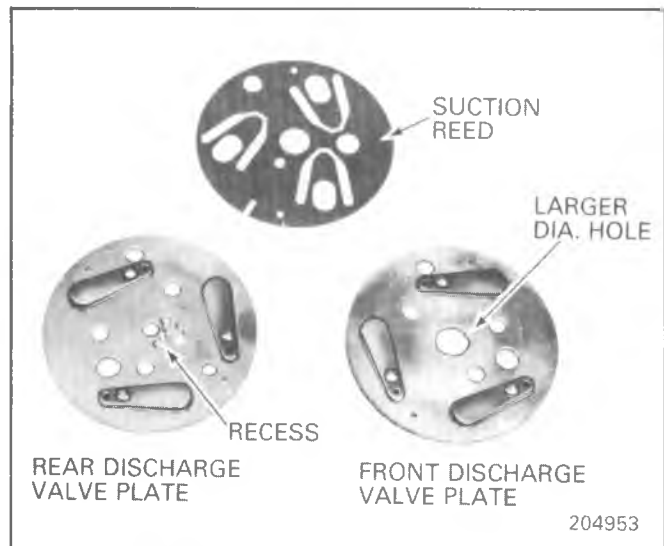

Fig. 1D-60 Front and Rear A-6 Discharge Valve Plates

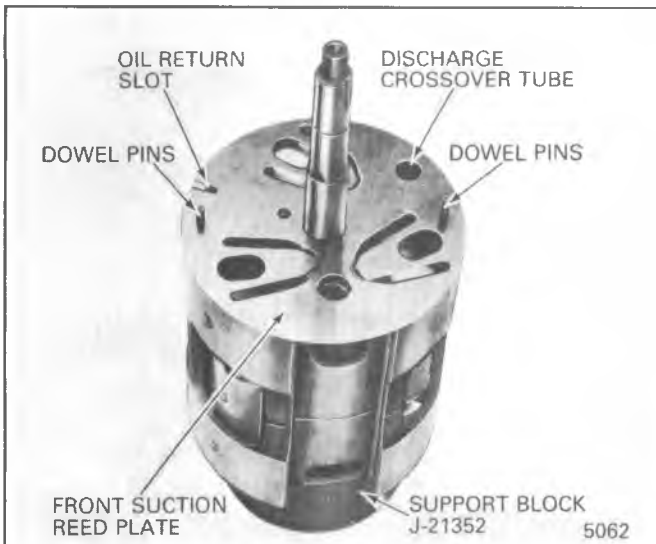

Fig. 1D-58 Installing A-6 Front Suction Reed

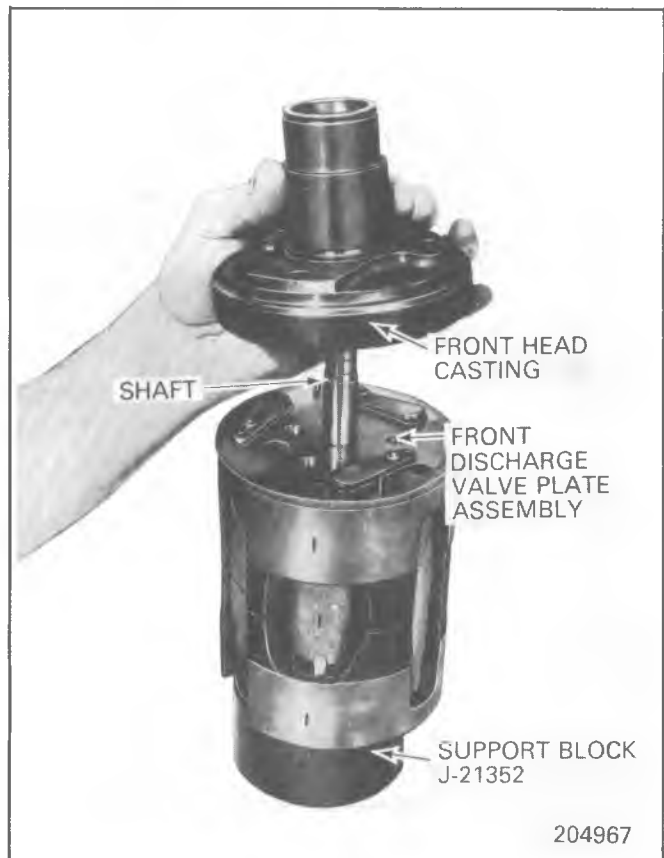

Fig. 1D-61 Installing A-6 Front Head Casting

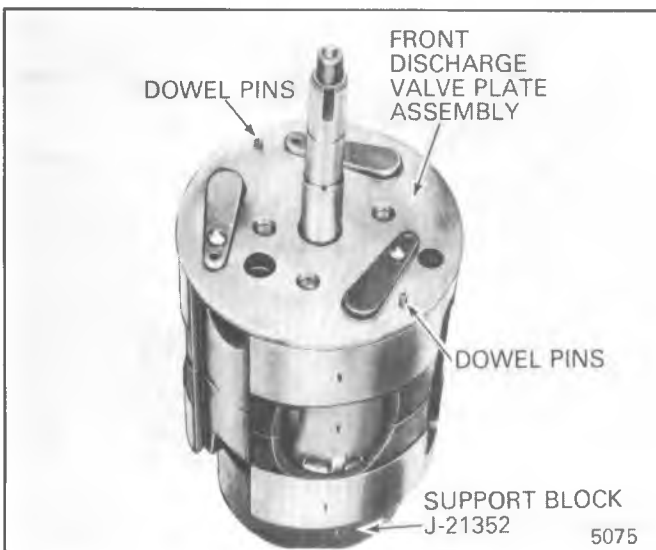

Fig. 1D-59 Installing A-6 Front Discharge Valve Plate

8. Generously lubricate new O-ring and angled groove at lower edge of front head casting with 525 viscosity refrigerant oil and install new O-ring into groove (Fig. 1D-62).

9. Coat inside machined surfaces of compressor shell with 525 viscosity refrigerant oil and position shell on Internal Cylinder and Shaft Assembly, resting on J21352 support block.

10. Using flat-side of a small screwdriver, gently position O-ring in around circumference of Internal Cylinder and Shaft Assembly until Compressor Shell slides down over Internal Cylinder and Shaft Assembly. As shell



Fig. 1D-62 A-6 Front Head O-Ring Installed



Fig. 1D-63 Installing A-6 Compressor Shell

slides down, line up oil sump with oil intake tube hole (Fig. 1D-63).

11. Holding Support Block J 21352 with one hand, invert Internal Cylinder and Shaft Assembly and place back into Holding Fixture J9396 with front end of shaft now facing downward. Remove Support Block.

12. Install new dowel pins in rear cylinder half, if previously removed.

13. Install new O-ring in oil pick-up tube cavity.

14. Lubricate Oil Pick-Up Tube with 525 viscosity refrigerant oil and install into cavity, rotating compressor mechanism to align tube with hole in shell baffle (Fig. 1D-64).

15. Now install new O-ring and bushing on rear-end of discharge cross-over tube (See Fig. 1D-53).

16. Install Rear Suction Reed over dowel pins, with slot towards sump.

17. Install Rear Discharge Valve Plate assembly over dowel pins, with reed retainers UP.

18. Position Inner Oil Pump Gear over shaft with previously applied identification mark UP.

19. Position Outer Oil Pump Gear over inner gear with previously applied identification mark up and, when standing facing oil sump, position outer gear so that it meshes with inner gear at the 9-o'clock position. The resulting cavity between gear teeth is then at 3-o'clock position (Fig. 1D-65).

20. Generously oil Rear Discharge Valve Plate assembly with 525 viscosity refrigerant oil around outer edge where large diameter O-ring will be placed. Oil the valve reeds, pump gears, and area where sealing surface will contact Rear Discharge Valve Plate.



Fig. 1D-64 Installing A-6 Oil Pick-up Tube

21. Using the 525 oil, lubricate new head to-shell O-ring and install on rear discharge valve plate, in contact with shell (Fig. 1D-66).

22. Install Suction Screen in rear head casting, using care not to damage screen.

23. Coat sealing surface on webs of compressor rear head casting with 525 viscosity refrigerant oil.

24. Install Rear Head assembly over studs on compressor shell. The two lower threaded compressor mounting holes should be in alignment with the compressor sump.

Make certain that suction screen does not drop out of place when lowering rear head into position (Fig. 1D-67).

## 1D-24 AIR CONDITIONING COMPRESSOR OVERHAUL

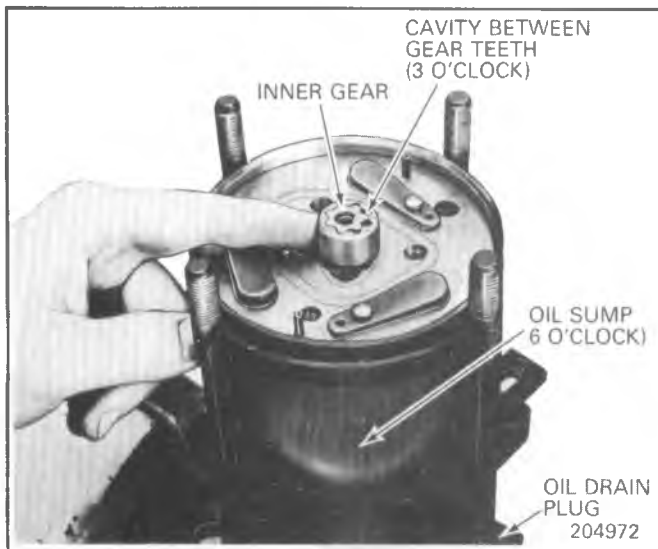

Fig. 1D-65 Positioning A-6 Oil Pump Gears



Fig. 1D-66 A-6 Shell-To-Front Head O-Ring Installation

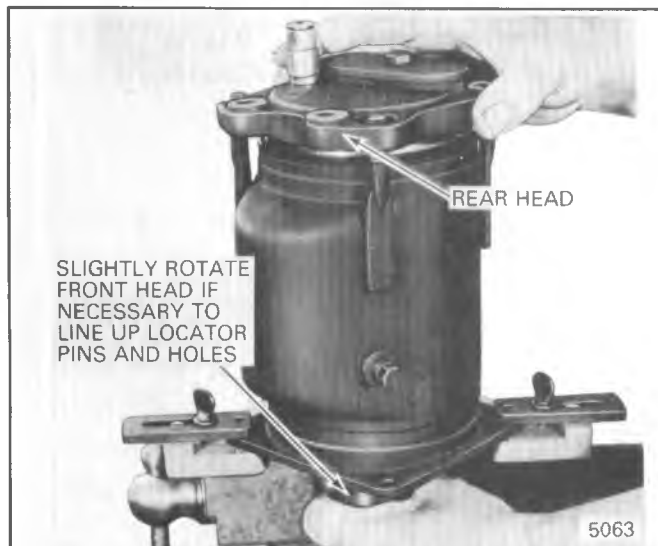

Fig. 1D-67 Installing A-6 Rear Head

If Rear Head assembly will not slide down over dowels in Internal Cylinder and Shaft Assembly, twist Front Head assembly back-and-forth very slightly by-hand until Rear Head drops over dowel pins (Fig. 1D-67).

25. Install nuts on threaded shell studs and tighten evenly to 34 N·m (25 lb. ft.) torque using a 0-60 N·m (0-50 lb. ft.) torque wrench.

26. Invert compressor in Holding Fixture and install compressor Shaft Seal as described in "A-6 Compressor Shaft Seal" Replacement procedure.

27. Install compressor Clutch Coil and Housing assembly as described in "A-6 Compressor Clutch Coil and Housing Asm." Replacement procedure.

28. Install compressor Pulley and Bearing assembly as described in "A-6 Compressor Pulley and Bearing" Replacement procedure.

29. Install compressor Clutch Plate and Hub assembly as described in "A-6 Compressor Clutch Plate and Hub Asm." Replacement procedure.

30. Add required amount of 525 viscosity refrigerant oil (see "C.C.O.T. Refrigerant Oil Distribution" in the Air Conditioning section).

31. Check for external and internal leaks as described in the following "A-6 Compressor Leak Testing" procedure found at the end of this over-haul section.

32. "Evacuate and charge the refrigerant system" according to the Discharging, Adding Oil, Evacuating and Charging Procedures for C.C.O.T. A/C Systems in the Air Conditioning section.

## A-6 COMPRESSOR LEAK TESTING (EXTERNAL AND INTERNAL)

### Bench-Check Procedure

1. Install Test Plate J 9625 on Rear Head of compressor.

2. Attach center hose of Manifold Gage Set on Charging Station to a refrigerant drum standing in an upright position and open valve on drum.

3. Connect Charging Station high and low pressure lines to corresponding fittings on Test Plate J 9625, using J 5420 Gage Adapters if hoses are not equipped with valve depressors.

- Suction port (low-side) of compressor has large internal opening. Discharge port (hi-side) has smaller internal opening into compressor.

4. Open low pressure control, high pressure control and refrigerant control on Charging Station to allow refrigerant vapor to flow into compressor.

5. Using a Leak Detector, check for leaks at Pressure Relief Valve, compressor Shell to cylinder, compressor front head seal, and compressor Shaft Seal. After checking, shut off low pressure control and high pressure control on Charging Station.

6. If an external leak is present, perform the necessary corrective measures and recheck for leaks to make certain the leak has been corrected.

7. Loosen the Manifold Gage hose connections to the Gage Adapters J 5420 connected to the low and high sides and allow the vapor pressure to release from the compressor.

8. Disconnect both Gage Adapters J 5420 from the Test Plate J 9625.

9. Rotate the complete compressor assembly (not the crankshaft or drive plate hub) slowly several turns to distribute oil to all cylinder and piston areas.

10. Install a shaft nut on the compressor crankshaft if the drive plate and clutch assembly are not installed.

11. Using a box-end wrench or socket and handle, rotate the compressor crankshaft or clutch drive plate on the crankshaft several turns to ensure piston assembly to cylinder wall lubrication.

12. Connect the Charging Station high pressure line or a high pressure gage and Gage Adapter J 5420 to the Test Plate J 9625 high side connector.

13. Attach an Adapter J 5420 to the suction or low pressure port of the Test Plate J 9625 to open the schrader-type valve.

Oil will drain out of the compressor suction port adapter if the compressor is positioned with the suction port downward.

14. Attach the compressor to the J 9396 Holding Fixture. Clamp the compressor Holding Fixture in a vise so that the compressor can be manually turned with a wrench.

15. Using a wrench, rotate the compressor crankshaft or drive plate hub 10-complete revolutions at a speed of approximately one-revolution per second.

Turning the compressor at less than one-revolution per second can result in a lower pump-up pressure and disqualify a good pumping compressor.

16. Observe the reading on HIGH pressure gage at the completion of the tenth revolution of the compressor. The pressure reading for a good pumping compressor should be 413.7 kPa (60 P.S.I.) or above for the A-6 compressor. A pressure reading of less than 344.75 kPa (50 p.s.i.) for the A-6 would indicate one or more suction and/or discharge valves leaking, an internal leak, or an inoperative valve and the compressor should be disassembled and checked for cause of leak. Repair as needed, reassemble and repeat the pump-up test. Externally leak test.

17. When the pressure pump-up test is completed, release the air pressure from the HIGH side and remove the Gage Adapters J 5420 and Test Plate J 9625.

18. Remove oil charge screw and drain the oil sump.

19. Allow the compressor to drain for 10 minutes, then charge with the proper amount of oil. The oil may be poured into the suction port.

If further assembly or processing is required, a shipping plate or Test Plate J 9625 should be installed to keep out air, dirt and moisture until the compressor is installed.

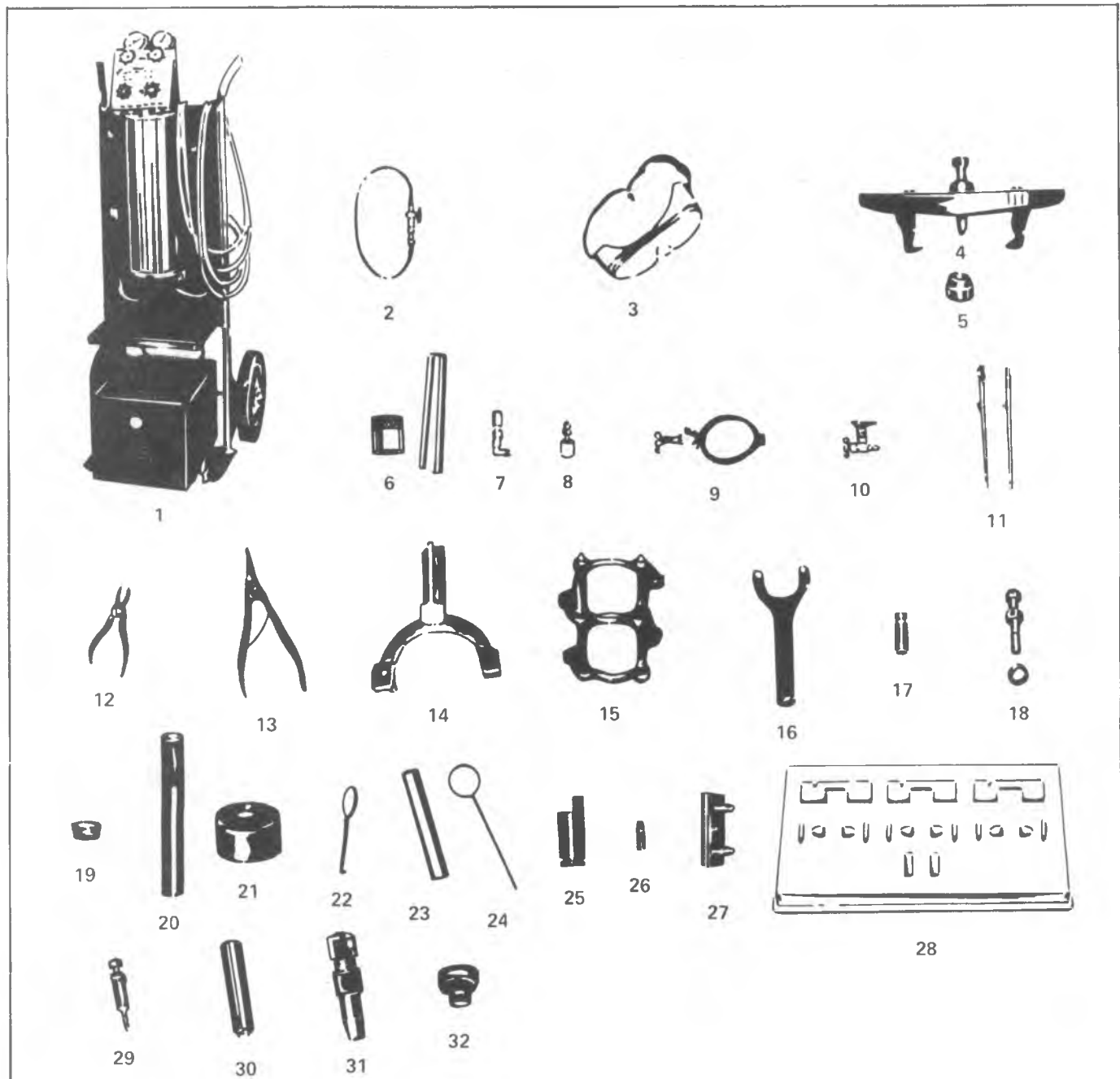

- |     |                     |                                  |     |         |  |     |           |                                      |
|-----|---------------------|----------------------------------|-----|---------|--|-----|-----------|--------------------------------------|
| 1.  | J 23500             | Charging Station                 | 12. | J 5403  | No. 21 Snap Ring Pliers                | 23. | J 9432    | Needle Bearing Installer             |
| 2.  | J 24095             | Oil Inducer                      | 13. | J 6435  | No. 26 Snap Ring Pliers                | 24. | J 9553-01 | Seal Seat "O" Ring Remover           |
| 3.  | J 5453              | Goggles                          | 14. | J 9396  | Compressor Holding Fixture             | 25. | J 21508   | Seal Seat "O" Ring Installer         |
| 4.  | J 8433              | Puller                           | 15. | J 9397  | Compressing Fixture                    | 26. | J 22974   | Shaft Seal Protector                 |
| 5.  | J 9395              | Puller Pilot                     | 16. | J 25030 | Clutch Hub Holding Tool                | 27. | J 9625    | Pressure Test Connector              |
| 6.  | J 9393-1            | Seal Seat                        | 17. | J 9399  | 9/16" Thin Wall Socket                 | 28. | J 9402    | Parts Tray                           |
|     | J 9393-2            | Remover + Installer              | 18. | J 9401  | Hub and Drive Plate Assembly Installer | 29. | J 9480-01 | Hub and Drive Plate Assembly Remover |
| 7.  | J 9459 — 7/16" — 20 | 90° Gauge Line                   | 19. | J 9398  | Pulley Bearing Remover                 | 30. | J 9392    | Seal Remover — Installer             |
|     | J 25499 — 3/8" — 24 | Adapter                          | 20. | J 8092  | Handle                                 | 31. | J 23128   | Seal Seat Remover — Installer        |
| 8.  | J 5420 — 7/16" — 20 | Straight Gauge Line              | 21. | J 21352 | Internal Assembly Support Block        | 32. | J 9481    | Pulley Bearing and Pulley Installer  |
|     | J 25498 — 3/8" — 24 | Adapter                          | 22. | J 5139  | Oil Pickup Tube Remover                |     |           |                                      |
| 9.  | J 23595             | Refrigerant Can Valve (Side-Tap) |     |         |  |     |           |                                      |
| 10. | J 6271-01           | Refrigerant Can Valve (Top-Tap)  |     |         |  |     |           |                                      |
| 11. | J 5421-02           | Pocket Thermometers (2)          |     |         |  |     |           |                                      |

Fig. 1D-105 Special Tools, A/C Refrigerant System and A-6 Compressor

## SECTION 2A

# FRAME

## CONTENTS

|                                  |      |
|----------------------------------|------|
| General Description .....        | 2A-1 |
| On Vehicle Service .....         | 2A-1 |
| Maintenance and Inspection ..... | 2A-1 |
| Underbody Inspection .....       | 2A-1 |
| Frame Inspection .....           | 2A-1 |
| Frame Alignment .....            | 2A-1 |
| Underbody Alignment .....        | 2A-4 |
| Excessive Body Damage .....      | 2A-4 |

## GENERAL DESCRIPTION

Light duty 10-30 Series frames are of the ladder channel section riveted type.

Figure 2A-1 thru 2A-4 illustrates typical light duty truck frames with crossmembers, body mounts and suspension attaching brackets. This section also includes general instructions for checking frame alignment and recommendations on frame repair.

The G-Van frame side rails, cross sills and outriggers are part of the underbody assembly which is a welded unit.

Misalignment of the underbody can affect door opening fits and also influence the suspension system, causing suspension misalignment. It is essential, therefore, that underbody alignment be exact to within  $\frac{1}{16}$  in. (1.9mm) of the specified dimensions.

## ON VEHICLE SERVICE

### MAINTENANCE AND INSPECTION

#### UNDERBODY INSPECTION

Raise the vehicle on a hoist (preferably a twin-post type).

Check for obvious floor pan deterioration.

Check for loose dirt and rust around the inside of the floor pan reinforcement member access holes. This is the first indication that corrosion may exist in hidden areas, and that repairs might be required before the final cleaning and protective treatment is performed.

Using a chisel, ensure that the drain provisions in the floor pan reinforcement members are open.

There are drain holes in the body side panels also. These holes can be opened by using a punch or drift. The side panel drain holes are in the rear section of the rocker panels, and in the lower rear quarter panels.

#### FRAME INSPECTION

Raise the vehicle on a hoist (preferably a twin-post type).

Check for obvious floor pan deterioration.

Check for loose dirt and rust around the inside of the frame rails, on top and at the ends where corrosion may exist in hidden areas. Check especially in the frame box sections for accumulation of debris.

#### FRAME ALIGNMENT

Horizontal frame checking can be made with tramming gages applied directly to the frame or by transferring selected points of measurement from the frame to the floor by means of a plum bob and using the floor layout for measuring. Fig. 2A-2 or 2A-4 may be used as a general guide in the selection of checking points; however, selection of these points is arbitrary depending on accessibility and convenience. An important point to remember is that for each point selected on one side of the frame, a corresponding point on the opposite side of the frame must be used for vertical checks, opposite and alternate sides for horizontal checks.

#### Vehicle Preparation

Points to remember when preparing vehicle for frame checking:

1. Place vehicle on a level surface.
2. Inspect damaged areas for obvious frame misalignment to eliminate unnecessary measuring.
3. Support vehicle so that frame sidemembers are parallel to the ground.

#### Tramming Sequence (Fig. 2A-1)

1. Dimensions to bolts and/or holes in frame extend to dead center of the hole or bolt.
2. Dimensions must be within  $\frac{3}{16}$  in. (4.7 mm).
3. If a tram bar is used, for horizontal alignment "X" - check from opposite and alternate reference points AA, BB and CC, as illustrated by the lines in Fig. 2A-1.

Error will result if a tram bar is not level and centered at the reference points.

4. Obtain vertical dimensions and compare the differences between these dimensions with the dimensions as shown in Fig. 2A-3 or 2A-4.

### Horizontal Check

1. Measure frame width at front and rear. If widths correspond to specifications, draw centerline full length of vehicle halfway between lines indicating front and rear widths. If frame widths are not correct, layout centerline as shown in Step 4.
2. Measure distance from centerline to corresponding points on each side of frame layout over entire length. Opposite side measurement should correspond within 3/16 in. (4.7 mm).
3. Measure diagonals marked A, B and C. If the lengths of intersecting diagonals are equal and these diagonals intersect the centerline, frame area included between these points of measurement may be considered in alignment.
4. If front or rear end of frame is damaged and width is no longer within limits, frame centerline may be drawn through the intersection of any two previously drawn pairs of equal, intersecting diagonals.

### Vertical Check

Vertical dimensions are checked with a tramming bar from indicated points on the frame (Figs. 2A-2 and 2A-4). For example, if the tram bar is set at point B with a vertical pointer length of 8-1/4 in. (206 mm), and at point E with a vertical pointer length of 5-1/4 in. (131 mm) (a height difference of 3 in. (75 mm)), the tram bar should be parallel with the frame. If the area is twisted or misaligned in any way, tram bar will not be parallel. Placing the tram bar vertical pointers on opposite sides of the frame side rail is preferable in that frame twist will show up during this vertical check. Fig. 2A-2 and 2A-4 show typical checking points, with dimensions for various frames shown in Fig. 2A-3.

### Frame Repair

#### Welding

Before welding up a crack in frame, a hole should be drilled at the starting point of the crack to prevent spreading. Widen V groove crack to allow complete weld penetration.

**NOTICE:** Do not weld into corners of frame or along edges of side rail flanges. Welding at these points will tend to weaken the frame and encourage new cracks.

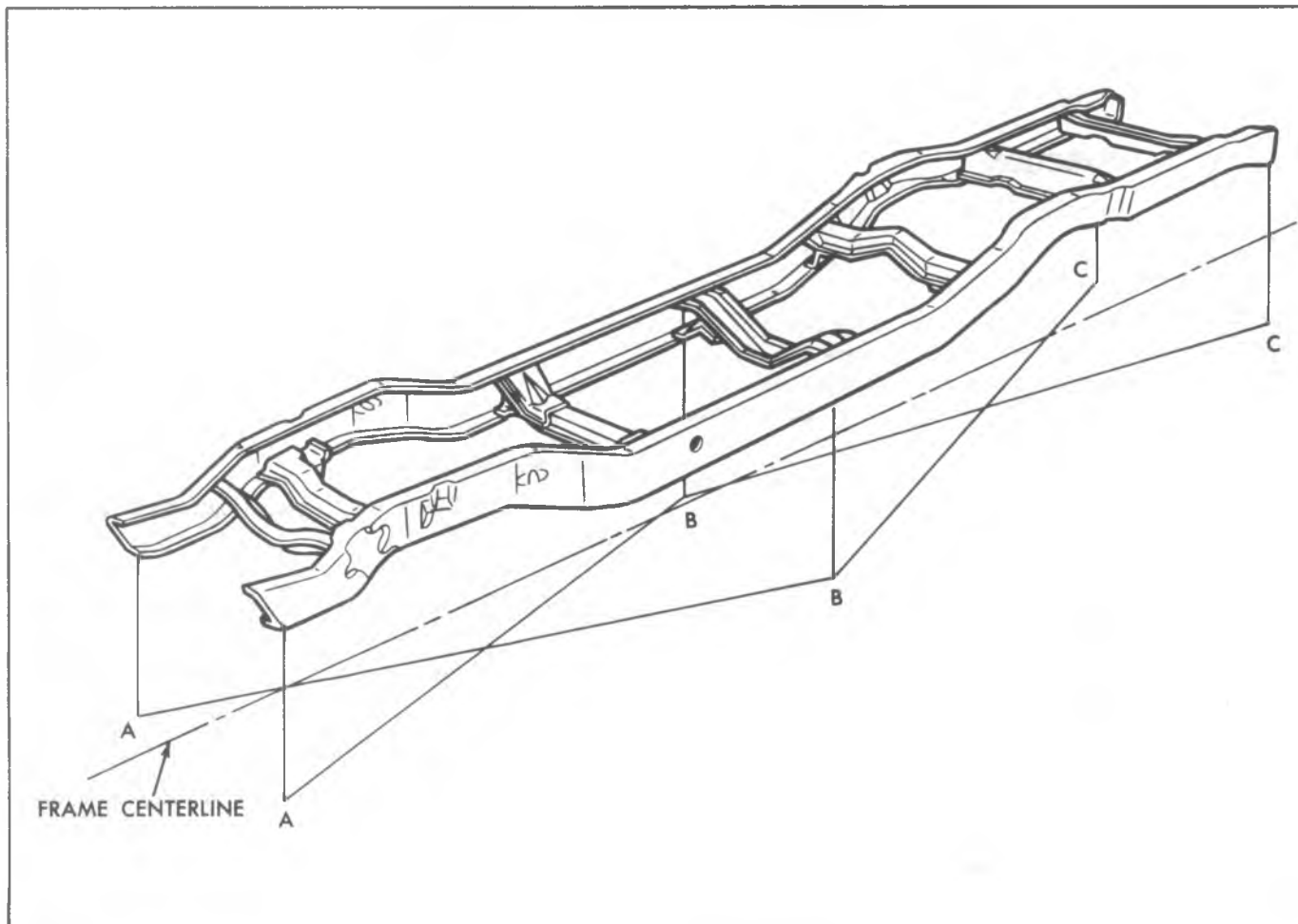

Fig. 2A-1—Frame Horizontal Checking—Typical



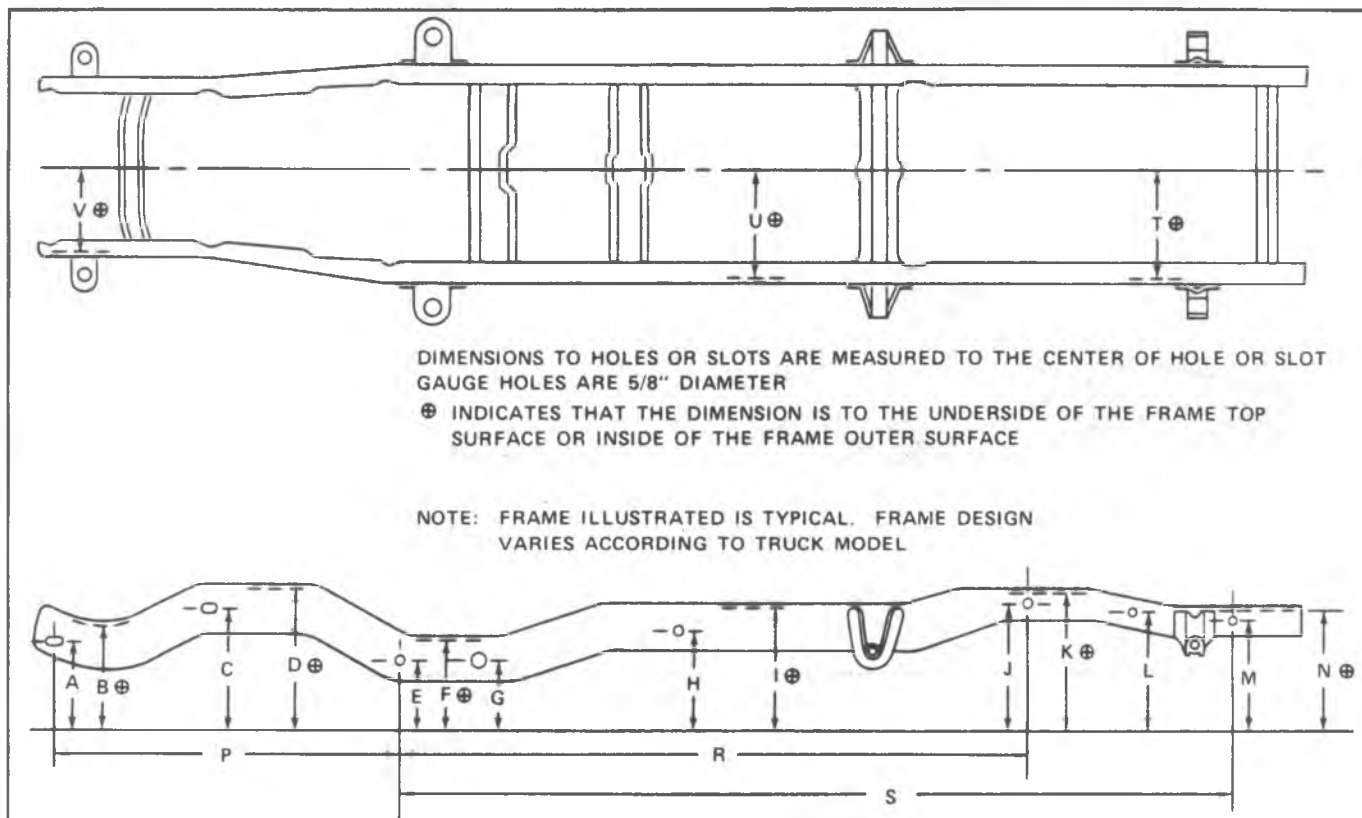

Fig. 2A-2--C-K-P Series Truck Frame

| Model                            | A      | B      | C      | D      | E      | F  | G  | H      | I      | J      | K      | L      | M      | N      | P      | R      | S        | T      | U      | V  |
|----------------------------------|--------|--------|--------|--------|--------|----|----|--------|--------|--------|--------|--------|--------|--------|--------|--------|----------|--------|--------|----|
| CA107                            | 13-3/8 | 15-1/4 | 16     | 19-7/8 | 12     | 13 | 10 | 14-7/8 | 17-3/4 | 17-3/4 | 19-7/8 | 16-3/4 | 15-5/8 | 17 3/4 | 68-1/2 | 76-1/2 | 110      | 16-7/8 | 16-7/8 | 14 |
| CA109                            | 13-3/8 | 15-1/4 | 16     | 19-7/8 | 12     | 13 | 10 | 14-7/8 | 17-3/4 | 17-3/4 | 19-7/8 | 16-3/4 | 15-5/8 | 17-3/4 | 69-5/8 | 86-1/2 | 120      | 16-7/8 | 16-7/8 | 14 |
| CA209                            | 13-3/8 | 15-1/4 | 17     | 19-7/8 | 12     | 13 | 10 | 14-7/8 | 17-3/4 | 17-3/4 | 19-7/8 | 16-3/4 | 15-5/8 | 17-3/4 | 69-5/8 | 86-1/2 | 120      | 16-7/8 | 16-7/8 | 14 |
| CA <sup>210</sup> <sub>310</sub> | 13-3/4 | 15-1/4 | 16     | 18-1/2 | 10     | 13 | 10 | 14-1/4 | 17-3/4 | 17-3/4 | 19-7/8 |        | 15-5/8 | 17-3/4 | 68-3/4 | 105    | 131      | 16-7/8 | 16-7/8 | 14 |
| CA314                            | 13-3/8 | 14 7/8 | 16     | 18-1/2 | 10     | 13 | 10 | 14-1/4 | 17-3/4 | 17-3/4 | 19-7/8 |        | 15-5/8 | 17-3/4 | 69-7/8 | 129    | 155-1/2  | 16-7/8 | 16 7/8 | 14 |
| KA107                            | 13-3/8 | 15-1/4 | 17     | 19-7/8 | 12-1/2 | 13 | 10 | 14-7/8 | 17-3/4 | 17-3/4 | 19-7/8 | 16-3/4 | 15-5/8 | 17-3/4 | 68-1/2 | 76-1/2 | 110      | 16-7/8 | 16-7/8 | 14 |
| KA <sup>109</sup> <sub>209</sub> | 13-3/8 | 15-1/4 | 17     | 19-7/8 | 12-1/2 | 13 | 10 | 14-7/8 | 17-3/4 | 17-3/4 | 19-7/8 | 16-3/4 | 15-5/8 | 17-3/4 | 68-1/2 | 86-1/2 | 120      | 16-7/8 | 16-7/8 | 14 |
| PA100                            | 7-5/8  | 9-3/8  | 11     | 14-5/8 | 9-1/2  | 13 | 10 |        |        | 9-1/2  | 13     |        | 10-7/8 | 13     | 71-7/8 | 36     | 89       | 16-7/8 | 16-7/8 | 14 |
| PA <sup>208</sup> <sub>308</sub> | 7-5/8  | 9-3/8  | 11-5/8 | 14-5/8 | 9-1/2  | 13 | 10 | 9-1/2  | 13     | 9-1/2  | 13     |        | 10-7/8 | 13     | 72-1/4 | 59     | 131      | 16-7/8 | 16-7/8 | 14 |
| PA <sup>210</sup> <sub>310</sub> | 7-5/8  | 9-3/8  | 11-5/8 | 14-5/8 | 9-1/2  | 13 | 10 | 9-1/2  | 13     | 9-1/2  | 13     | 10-7/8 | 10-7/8 | 13     | 71-7/8 | 67     | 153      | 16-7/8 | 16-7/8 | 14 |
| PA314                            | 7-5/8  | 9-3/8  | 11-5/8 | 14-5/8 | 9-1/2  | 13 | 10 | 9-1/2  | 13     | 9-1/2  | 13     | 10-7/8 | 10-7/8 | 13     | 71-7/8 | 91     | 177      | 16-7/8 | 16-7/8 | 14 |
| CA105                            | 13-3/8 | 15 1/4 | 17     | 19-7/8 | 12     | 13 | 10 |        |        | 14-1/4 | 20     | 17-3/4 | 15-5/8 | 17-3/4 | 69-5/8 | 46     | 88       | 16-7/8 | 16-7/8 | 14 |
| KA105                            | 13-3/8 | 15-1/4 | 17     | 19-7/8 | 12-1/2 | 13 | 10 |        |        | 14-1/4 | 20     | 17 3/4 | 15-5/8 | 17 3/4 | 69-5/8 | 46     | 88       | 16-7/8 | 16-7/8 | 14 |
| PE<br>31132<br>(137)             | 9-1/8  | 11-1/2 | 10-7/8 |        | 9-1/2  | 13 | 10 | 9-1/2  | 13     | 9-1/2  | 13     | 10-7/8 | 10-7/8 | 13     | 68-1/2 | 71     | 157      | 16-7/8 | 16-7/8 | 14 |
| PE<br>31432<br>(157)             | 9-1/8  | 11-1/2 | 10-7/8 |        | 9-1/2  | 13 | 10 | 9-1/2  | 13     | 9-1/2  | 13     | 9-7/8  | 10-7/8 | 13     | 68-1/2 | 92-1/2 | 178-1/2  | 16-7/8 | 16-7/8 | 14 |
| PE<br>31832                      | 9-1/8  | 11-1/2 | 10-7/8 |        | 9-1/2  | 13 | 10 | 9-1/2  | 13     | 9 1/2  | 13     | 10-7/8 | 10-7/8 | 13     | 68-1/2 | 112    | 240-3/16 | 16-7/8 | 16-7/8 | 14 |

Fig. 2A-3--C-K-P Series Frame Reference Dimensions

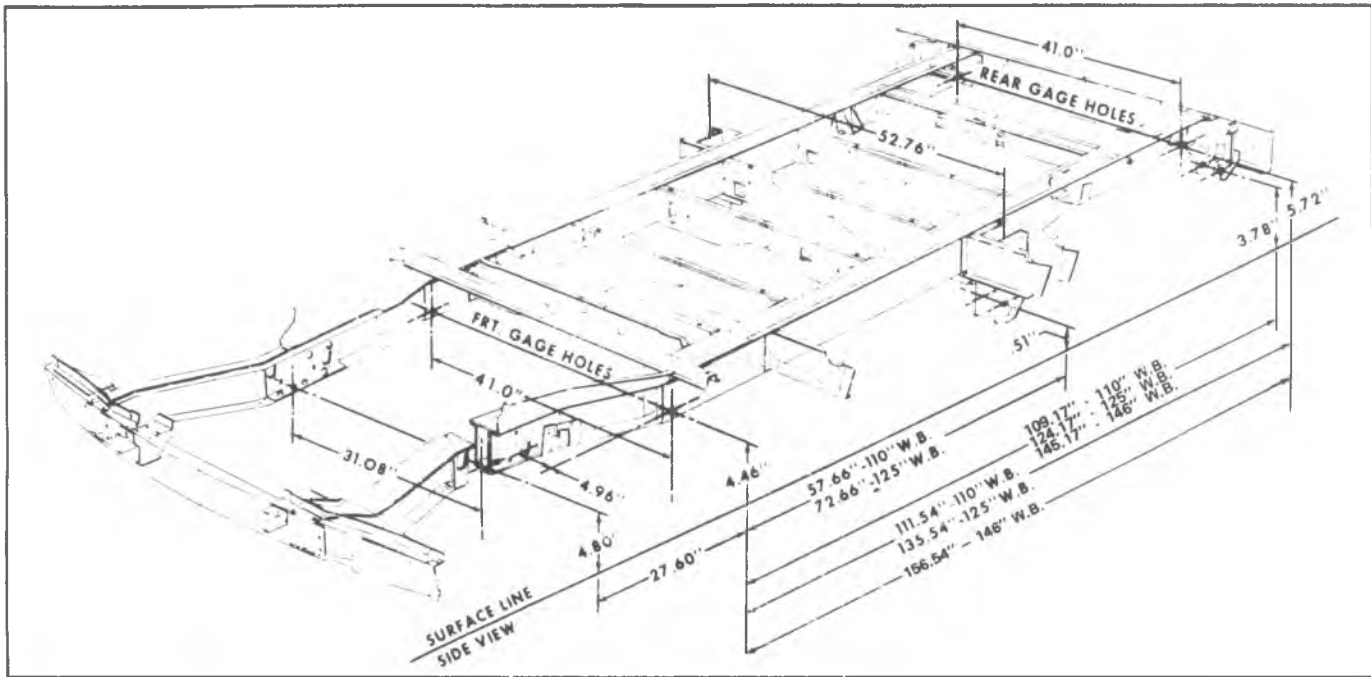

Fig. 2A-4-G Van Truck Reference Dimensions

### Bolting

Wherever rivets or failed bolts are replaced, bolt hole must be as near the O.D. of the bolt as possible to prevent bolt from working and wearing. Drill out and line ream hole (or holes) to the bolt O.D.

### UNDERBODY ALIGNMENT

One method of determining the alignment of the underbody is with a tram gage which should be sufficiently flexible to obtain all necessary measurements up to three quarters the length of the vehicle. A good tramping tool is essential for analyzing and determining the extent of collision misalignment present in underbody construction.

### MEASURING

To measure the distance accurately between any two reference points on the underbody, two specifications are required.

1. The horizontal dimension between the two points to be trammed.

2. The vertical dimension from the datum line to the points to be trammed.

The tram bar should be on a parallel to that of the body plane. The exception to this would be when one of the reference locations is included in the misaligned area; then the parallel plane between the body and the tram bar may not prevail. After completion of the repairs, the tram gage should be set at the specified dimension to check the accuracy of the repair operation.

### EXCESSIVE BODY DAMAGE

If damage is so extensive that key locations are not suitable as reference points, repair operations should always begin with the underbody area. All other components should be aligned progressively from this area. Unlike the conventional type of frame design, the unitized type of body construction seldom develops the two conditions of "twist" and "diamond" in the underbody area as a result of front or rear end collisions, therefore, there usually is an undamaged area suitable as a beginning reference point.

## SECTION 2B

# BUMPERS

**NOTICE:** Fasteners are important attaching parts in that they could affect the performance of vital components and systems, and/or could result in major repair expense. They must be replaced with one of the same part number or with an equivalent part if replacement becomes necessary. Do not use a

replacement part of lesser quality or substitute design. Torque values must be used as specified during reassembly to assure proper retention of these parts. For prevailing torque nut(s) and bolt(s), refer to the "Reuse of Prevailing Torque Nut(s) and Bolt(s)" chart in Section 10.

### CONTENTS

|   |      |   |      |
|---|------|---|------|
| General Description.....                    | 2B-1 | Rear Step Bumper - C and K Models ..... | 2B-2 |
| Service Procedures - 10 thru 30 series..... | 2B-1 | Front Bumper G Series .....             | 2B-2 |
| Front Bumper - C, K and P Models .....      | 2B-1 | Rear Bumper G Series .....              | 2B-3 |
| Rear Bumper - C and K Models.....           | 2B-2 | Rear Bumper G Series .....              | 2B-3 |

## GENERAL DESCRIPTION

All truck front and rear bumpers are of a single piece design. Bumper attachments are the standard bracket and brace to frame mountings. This section contains procedures for the removal and installation of face bar, brackets, braces and license plate brackets.

## SERVICE PROCEDURES-10 THRU 30 SERIES

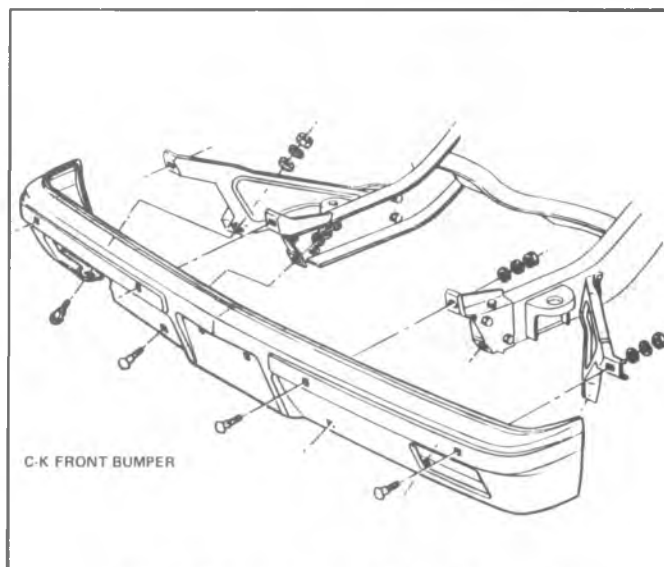

Fig. 2B-1--Front Bumper-C, K and P Models

### FRONT BUMPER-C, K AND P MODELS

#### Removal Fig. 2B-1, 2B-2

1. Remove bolts securing bumper face bar to left and right bumper brackets.
2. Remove bolts securing bumper face bar to left and right bumper braces and remove bumper from vehicle.
3. If necessary, remove the brackets and braces from frame by removing the bolt attachments.
4. If equipped with bumper guards, the bumper is removed in same manner as above.

#### Installation

Assemble and install front bumper following the removal procedure in reverse order.

### REAR BUMPER-C AND K MODELS (FIG 2B- 3)

#### Removal

1. Remove bolts attaching bumper face bar to left and right bumper brace. Disconnect license lamp wiring on suburban, panel and pickup models.
2. Remove bolts attaching bumper face bar to left and

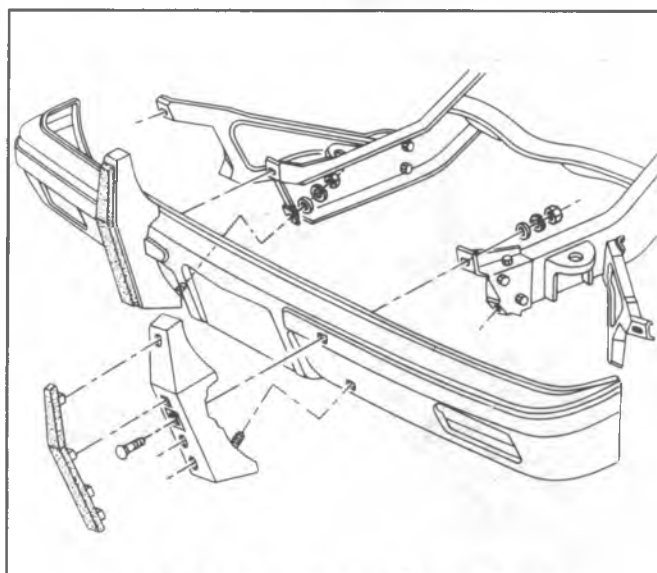

Fig. 2B-2--C, K Model Front Bumper Guards

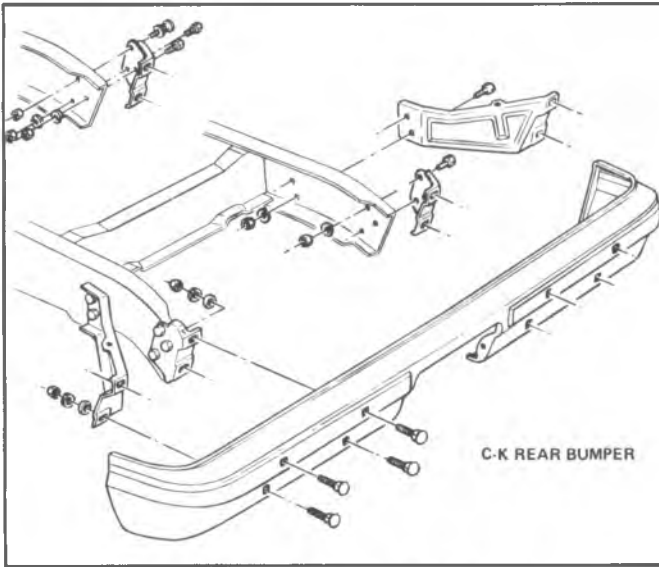

Fig. 2B-3--Rear Bumper - C, K Models

right bumper bracket.

3. Remove bumper from vehicle.
4. If necessary, remove the rear stone shields and the bumper brackets and braces from frame by removing bolt attachments.

**Installation**

Install rear bumper following removal procedure in reverse order. Connect license lamp wiring on suburban, panel, and pickup models.

**REAR STEP BUMPER C AND K MODELS**

**Removal (Fig. 2B-4)**

1. Disconnect license lamp wiring.
2. Remove bolts connecting bumper to braces.
3. Remove bolts retaining bumper to brackets.
4. Remove bumper assembly.
5. Remove bolts securing bumper brace to frame and bumper brackets and reinforcements to frame if necessary.

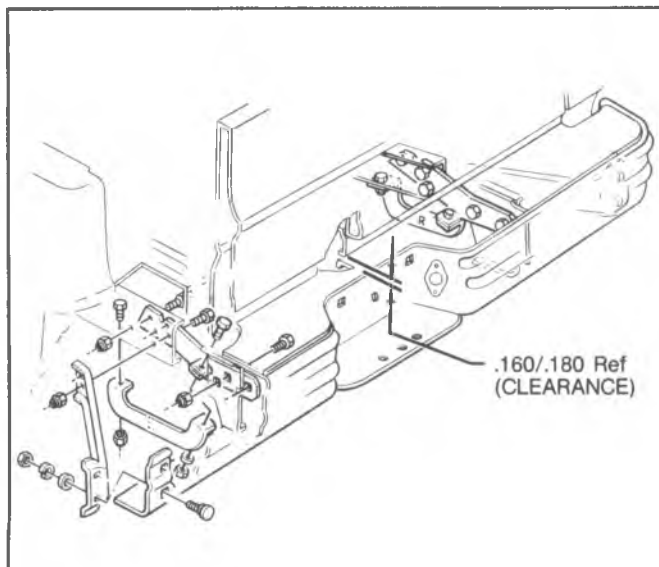

Fig. 2B-4--Rear Step Bumper C and K Models

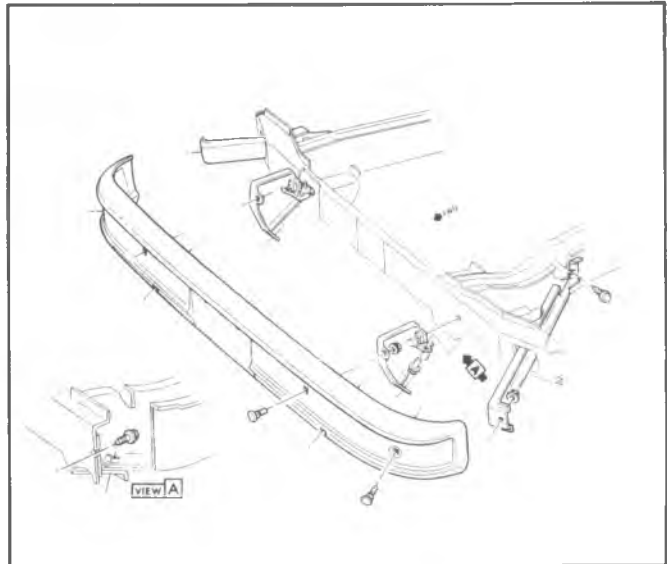

Fig. 2B-5--Front Bumper - G Models

**Installation**

Install rear step bumper by reversing removal procedure. Connect license lamp wiring.

**FRONT BUMPER - G MODELS**

**Removal Fig. 2B-5, 2B-6**

1. Remove nuts securing bumpers to brackets and braces from left and right side. Remove bumper.
2. If necessary to remove the braces and brackets, remove screws securing brackets and braces to sheet metal.
3. If equipped with bumper guards (Fig. 2B-6) they may be removed from the face bar at this time.

**Installation**

Reverse removal steps to install bumpers.

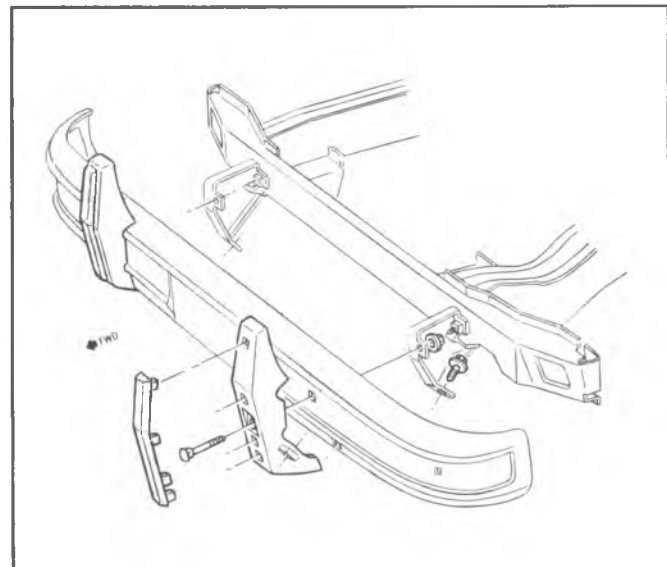

Fig. 2B-6--G-Models Front Bumper Guards

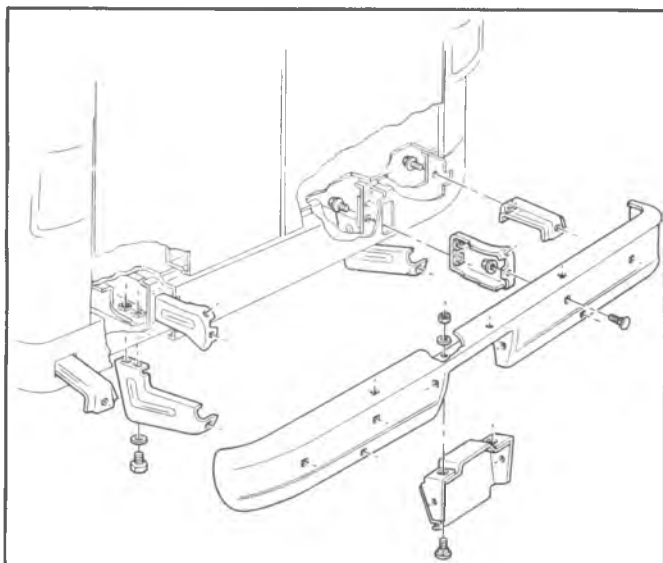

Fig. 2B-7--Rear Bumper-G Models

### REAR BUMPER-G MODELS

#### Removal Fig. 2B-7

1. Remove nuts securing bumper to left hand and right hand brackets and braces and remove the bumper.
2. Remove the license plate support nut and bolts.
3. Remove bolts securing left hand and right hand brackets and braces to body.

The bumper may be removed with brackets and braces attached if necessary.

#### Installation

Install in reverse order of removal.

## SPECIFICATIONS

#### TORQUE SPECIFICATIONS C, P AND K

|  |              |
|--|--------------|
| Front Bumper .....                         | .35 ft.-lbs. |
| Front Bumper Bracket and Brace .....       | .70 ft.-lbs. |
| Rear Bumper to Outer Bracket .....         | .35 ft.-lbs. |
| Rear Bumper Outer Bracket and Brace .....  | .50 ft.-lbs. |
| License Plate Bracket .....                | .18 ft.-lbs. |
| Gravel Deflector .....                     | .85 in.-lbs. |
| Rear Step Bumper to Bracket or Frame ..... | .40 ft.-lbs. |

#### TORQUE SPECIFICATIONS G

|   |               |
|---|---------------|
| Front Face Bar to Bracket .....         | .24 ft.-lbs.  |
| Bracket to Cross Sill .....             | .24 ft.-lbs.  |
| License Plate Bracket to Face Bar ..... | .100 in.-lbs. |
| Rear Face Bar to Brackets .....         | .55 ft.-lbs.  |
| Bracket to Floor .....                  | .55 ft.-lbs.  |

Fig. 2B-ST--Specifications

1990-1991

1991-1992

1992-1993

1993-1994

1994-1995

1995

1996

1997

1998

1999

2000

## SECTION 2C

# SHEET METAL

**NOTICE** Fasteners are important attaching parts in that they could affect the performance of vital components and systems, and/or could result in major repair expense. They must be replaced with one of the same part number or with an equivalent part if replacement becomes necessary. Do not use a replacement part of lesser quality or substitute design. Torque values must be used as specified during reassembly to assure proper retention of these parts. For prevailing torque nut(s) and bolt(s), refer to the "Reuse of Prevailing Torque Nut(s) and Bolt(s)" chart in Section 10.

### CONTENTS

|                           |      |  |       |
|---------------------------|------|--|-------|
| General Description ..... | 2C-1 | Front Sheet Metal .....                        | 2C-6  |
| On Vehicle Service .....  | 2C-1 | Radiator Support .....                         | 2C-7  |
| Hood - CK Models .....    | 2C-1 | Front Fender .....                             | 2C-8  |
| Cowl Top Vent Panel ..... | 2C-1 | Front Fender and Skirt .....                   | 2C-8  |
| Hood Hinge .....          | 2C-2 | Running Board .....                            | 2C-8  |
| Hood Lock Mechanism ..... | 2C-2 | Fender Skirt - P Series .....                  | 2C-8  |
| Hood Assembly .....       | 2C-2 | Adhesive Bodyside Molding (All Vehicles) ..... | 2C-8  |
| Hood .....                | 2C-3 | Wood Grain Applique .....                      | 2C-9  |
| Hood Hinge .....          | 2C-3 | Decal Applique Procedure (All Vehicles) .....  | 2C-10 |
| Hood Lock .....           | 2C-3 | Specifications .....                           | 2C-11 |
| Hood Bumper .....         | 2C-5 |  |       |

## GENERAL DESCRIPTION

### CK MODELS

The chassis sheet metal assembly is attached to the frame and body at adjustment points. The front of the assembly is supported by two mounts located at the frame side rails. Fore and aft and side adjustment is allowed by oversize holes at the fender rear attaching point and chassis sheet metal mounts. Special shims at the rear locations allow adjustment of the rear of the assembly. The lower rear edge of the assembly is attached to the body at the rocker panel by bolts on each side. Shims are used at this location to provide in and out adjustment at the rear of the fender. The bolts that retain the sheet metal braces must be torqued to the required torques. If these bolts are loose, the braces will not provide additional support for the sheet metal assembly.

### G MODELS

The front end sheet metal design does not include the radiator support and fenders as loose items inasmuch that

these items are welded together as an integral part of the body.

Front end sheet metal includes the hood assembly, hood hinges, hood lock catch and support, a hood rod assembly which supports the hood, a bolted radiator-upper tie bar, and series designation plates and hoods emblems.

### Anti-Corrosion Information

"Anti-corrosion materials have been applied to the interior surfaces of some metal panels to provide rust resistance. When servicing these panels, areas on which this material has been disturbed should be properly recoated with service-type anti-corrosion material."

## ON VEHICLE SERVICE

### HOOD - CK MODELS

#### Cowl Top Vent Panel (Fig. 2C-1)

#### Replacement

1. Remove wiper arms.

2. Open hood and remove two screws at each wiper nozzle attachment.
3. Remove four screws at front of cowl panel.
4. Pry the five plastic fasteners loose from windshield frame. Remove the panel.
5. Reverse the above listed procedure to replace.

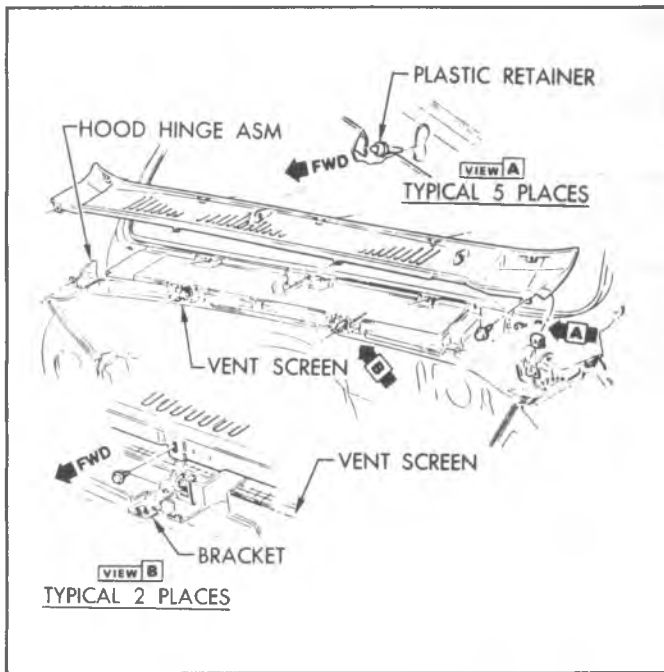

Fig. 2C-1--Cowl Top Vent Panel

**Hood Hinge (Fig. 2C-2)**

**Replacement**

1. Prop the hood in the extreme open position and place protective covering over the cowl and fenders. Scribe position of hinge attachment to hood.
2. Remove two bolts link assembly to hood and two bolts at hinge to the hood.
3. Remove two bolts link assembly to fender inner, remove link.
4. Remove wiper arms and at the cowl cover panel remove four screws and lift up without removing for access.

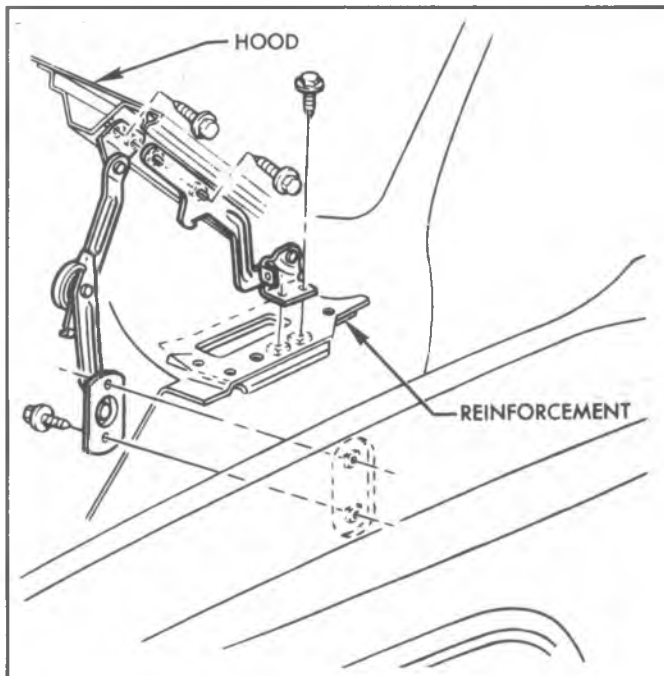

Fig. 2C-2--Hood Hinge -CK Models

5. Remove two bolts hinge to rear reinforcement at the body and remove hinge.
6. Replace by reversing the above procedure.

**Hood Lock Mechanism**

The hood latch assembly and bracket are mounted to the Radiator Support. Elongated holes in the bracket are provided for alignment purposes. A separate secondary latch is mounted to the striker plate in the hood. See Fig. 2C-3 and 2C-4.

**Replacement**

1. Open hood and remove the two bolts holding the hood latch to the bracket.  
If original hood lock assembly is to be replaced, scribe a line around lock for alignment on installation.
2. Replace hood latch assembly and bolts loosely.
3. Align within scribe marks and tighten bolts.

**Hood Bumper Adjustment**

Hood Bumpers must be adjusted until hood and fender line up flush at front corner.

**Hood**

**Removal**

1. Open hood and prop in full open position.  
If hood is to be reinstalled and present alignment is satisfactory, mark each hinge in relation to hood, to assure original alignment.
2. Remove two (2) cap screws which attach each hinge

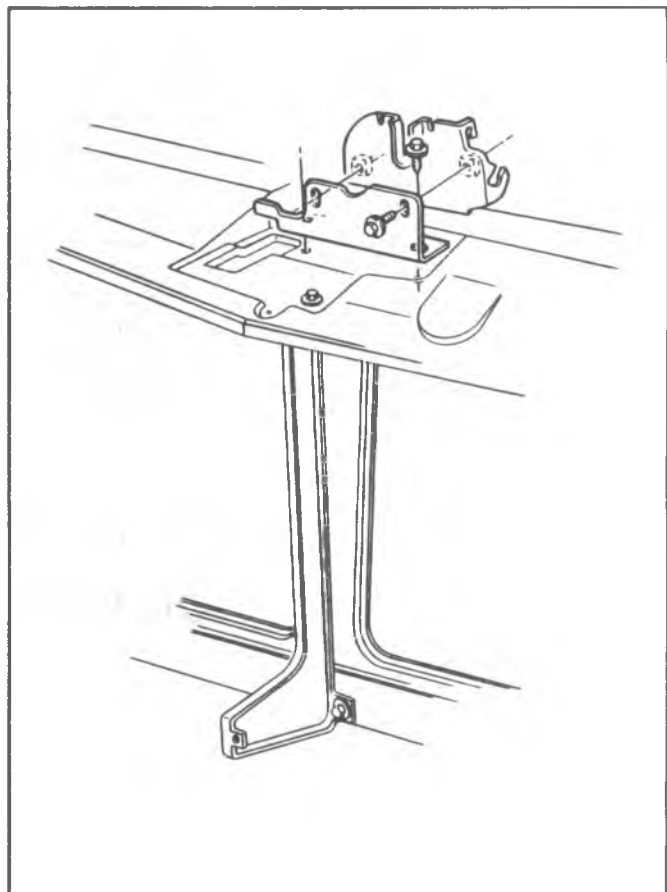

Fig. 2C-3--Primary Hood Latch -CK Models



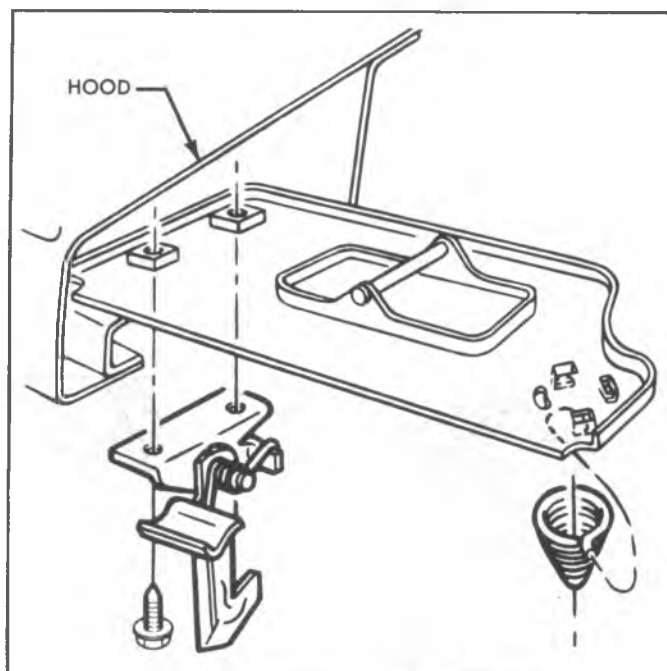

Fig. 2C-4-Secondary Latch -CK Models

and link to hood; then with a helper remove hood from vehicle.

#### Installation

1. If original hood is to be installed, position hood to hinges and links and install four cap screws snug which attach hinges and links to hood.  
If a new hood is to be installed, perform procedures as outlined under Alignment, directly below.
2. Shift hood on hinges to location marks made before removal of hood, then tighten attaching cap screws at hinges firmly. Close hood and check fit. If necessary to align hood perform procedure as outlined under "Alignment" which follows.

#### Alignment

1. Loosen hood hinge bolts.  
Note that the rear most bolt holes in hinge are slotted to allow hood to move back and forth.
2. Adjust bracket at hood latch, as necessary. Slotted hole in the bracket allow movement up or down at the latch, and right or left at the radiator support.
3. Adjust hood bumper as necessary in proportion to the latch.

#### Hood - G Model

The alignment of the hood is controlled by the position of the hood hinges and the height of the two bumpers located one at each side of the radiator support. The adjustment at the hood lock must be made after the hinges and bumpers are properly adjusted (Refer to Hood Lock Adjustment Fig. 2C-7). To align the hood and lock proceed as follows:

#### Hood Hinge (Fig. 2C-5)

#### Hood Lock

A bolt-type hood lock is used as shown in Fig. 2C-7. The lock bolt, located on the hood, dovetails with the mounted striker plate, preventing upward or downward

movement of the hood while the vehicle is in motion. Integral with the striker plate is the combination lock release lever and safety catch.

1. Scribe a line around the entire hinge plate to be repositioned.
2. Loosen the appropriate screws and shift the position of the hood into correct alignment using the scribe marks to check amount of movement. Check alignment by tightening screws and closing the hood.

#### Replacement

1. Open hood and remove the four bolts holding the combination lock catch and lock bolt.  
If original hood lock assembly is to be replaced, scribe a line around lock for alignment on installation.
2. Place hood lock assembly in position.
3. Adjust as outlined under Adjustments.

#### Adjustment

Hood lock assembly to be adjusted fore and aft until hood lock bolt enters center of elongated guide. Bending bolt to accomplish this adjustment may seriously effect lock operation and safety catch engagement and is, therefore not recommended.

1. Adjust lock bolt as shown in Fig. 2C-7.
2. Open hood and adjust tightness of catch assembly so that it is just "snug" enough to hold lock bolt in position.
3. Close hood in a normal manner.
4. Raise hood again; lock bolt assembly will have shifted to operating position. Tighten bolts fully. Further adjustment may be made at lock bolt support, if necessary.
5. Adjust lock bolt to obtain a secure hood closure and reasonable lock release effort.

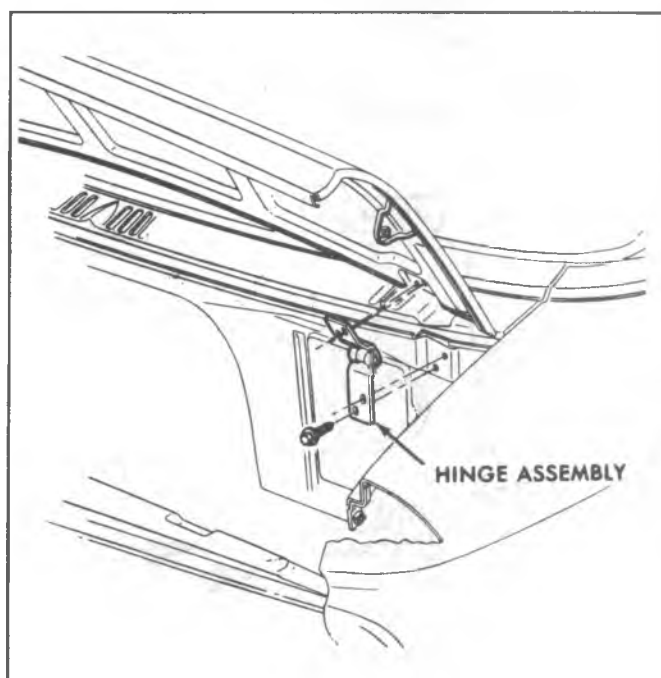

Fig. 2C-5-Hood Hinge-G Model

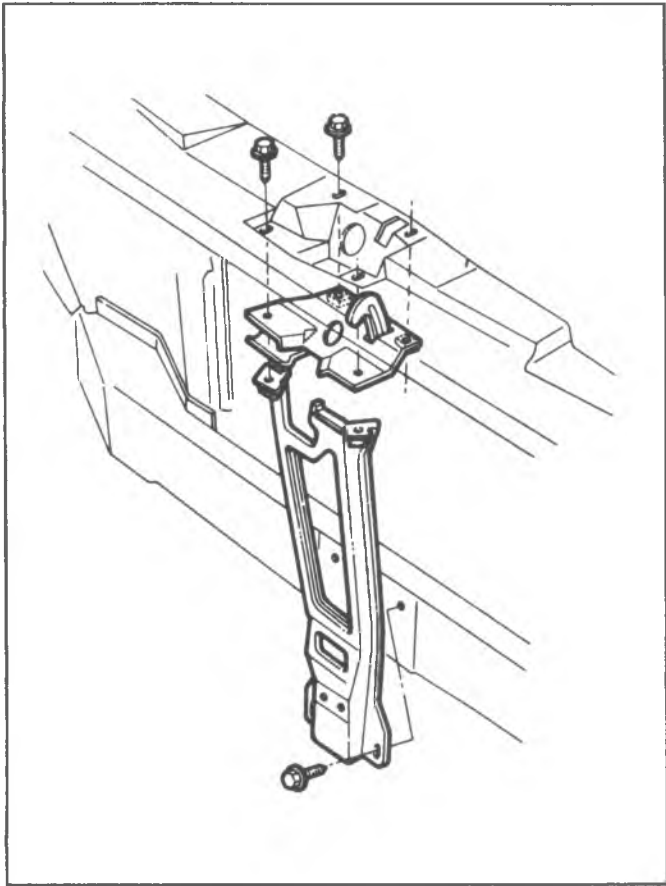

Fig. 2C-6--Hood Lock Catch Assembly-G Model

**HOOD CABLE RELEASE - CK MODELS  
(FIG. 2C-8)**

**Replacement**

1. Release the hood from below, using a suitable rod, by pressing on the hood release tab at the right side of the lock assembly.
2. Remove the cable at the lock assembly.
3. Remove hood release handle to kickpad attaching screws.

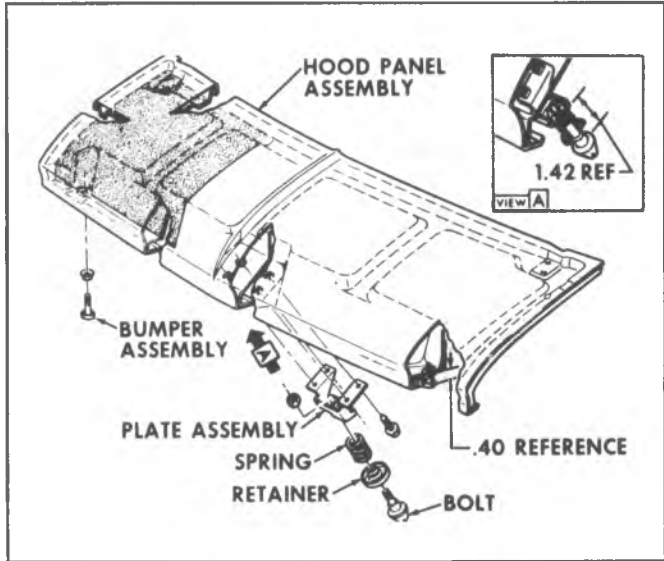

Fig. 2C-7--Hood, Bumpers and Latch-G Model

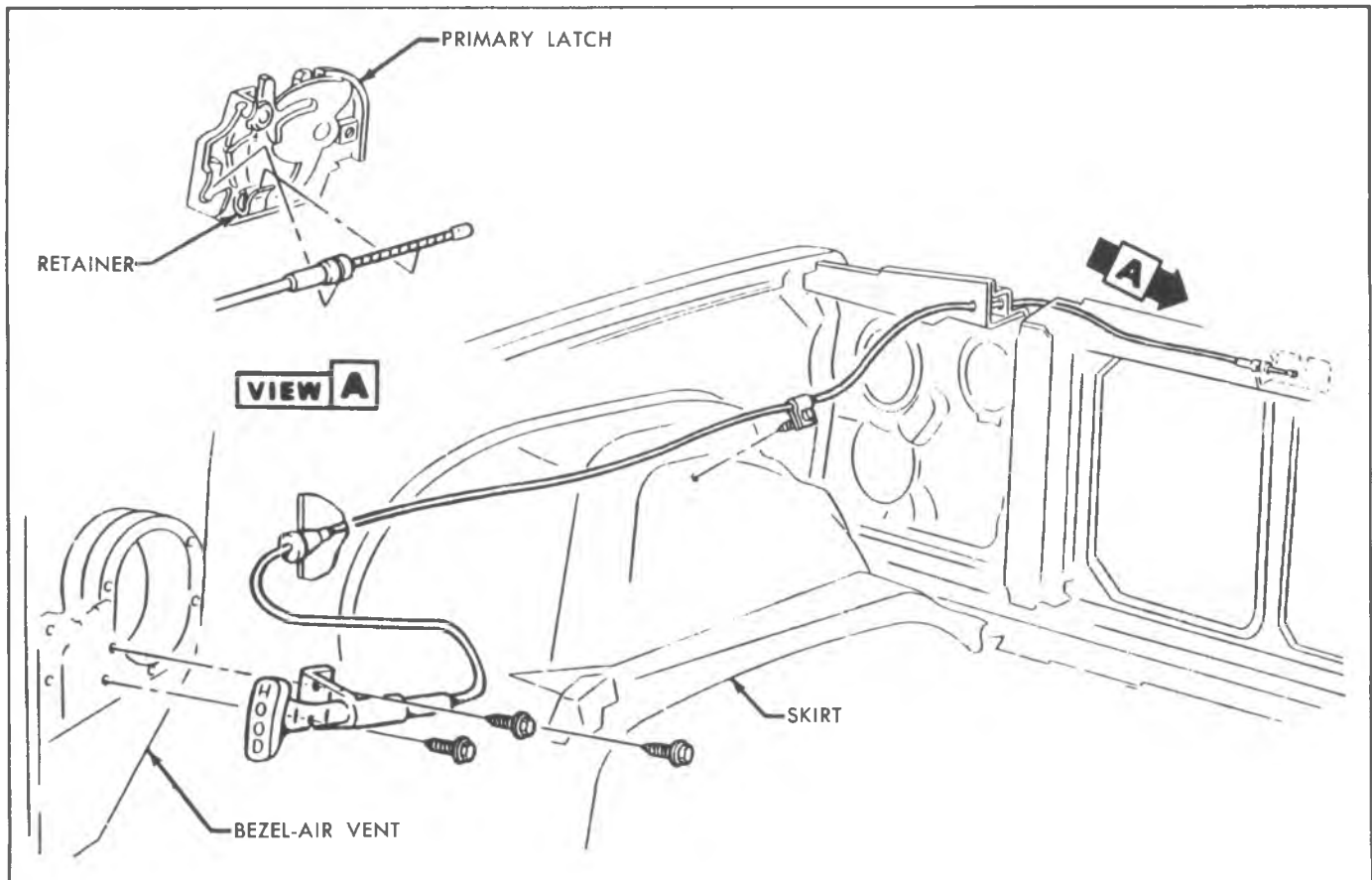

Fig. 2C-8--Hood Release Cable - CK Models

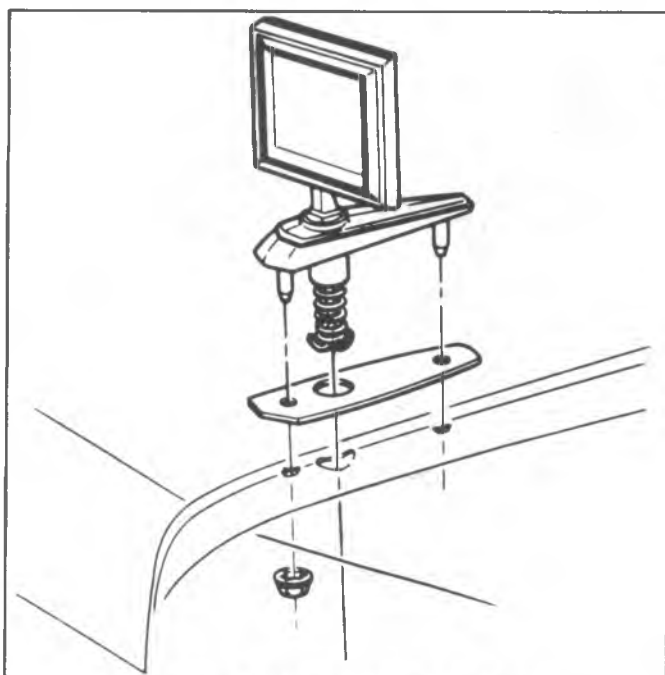

Fig. 2C-9--Hood Emblem - CK Models

4. Remove hood release cable.
5. To install, reverse Steps 2 through 4.

### HOOD EMBLEM - CK MODELS (FIG. 2C-9)

#### Hood Bumper

Adjust hood bumpers so that hood top surface is flush with the fender and grille top surfaces.

#### Hood - G Model (Fig. 2C-7)

##### Removal

1. Lay a fender cover along cowl top to prevent hood from scratching painted surfaces.
2. Open hood and prop in full open position.  
If hood is to be reinstalled and present alignment is satisfactory, mark each hinge in relation to hood, to assure original alignment.
3. Remove two cap screws which attach each hinge to hood; (Fig. 2C-5) then with a helper remove hood from vehicle.

##### Installation

1. If original hood is to be installed, position hood to hinges with helper and install four cap screws snug which attach hinges to hood.
2. Install rod assembly.  
If a new hood is to be installed, perform procedures as outlined under Alignment, directly below.
3. Shift hood on hinges to location marks made before removal of hood, then tighten attaching cap screws at hinges firmly. Close hood and check fit. If necessary to align hood perform procedure as outlined under "Alignment" which follows.

#### Alignment

1. Loosen hood hinge bolts.  
Note that the rear bolt holes in hinge is slotted to allow hood trailing edge to move up and down.
2. Adjust hood bumpers so that hood and adjacent surfaces are flush.
3. Perform hood lock adjustment as outlined in this section if necessary.

Hood Lock Assembly to be adjusted fore and aft until nubble (part of Hood Lock Bolt Support Assembly) enters center of elongated guide (Socket). Bending nubble to accomplish this adjustment may seriously effect lock operation and safety catch engagement and is, therefore, NOT RECOMMENDED.

#### Hood Support Rod - G Model

Refer to Fig. 2C-10 for removal and installation of hood support rod.

### CARBURETOR OUTSIDE AIR INLET

#### SNORKELS (Fig. 2C-11)

##### Removal

1. Raise hood and remove carburetor air duct from air snorkel by sliding duct rearward.
2. Disconnect the attachment incorporated in the duct attaching the air snorkel to radiator support turn and remove from vehicle.

### LOWER RADIATOR GRILLE (FIG. 2C-12)

### RADIATOR GRILLE PANEL OR BRACKETS (FIG. 2C-13)

### GRILLE MOLDING (FIG. 2C-14)

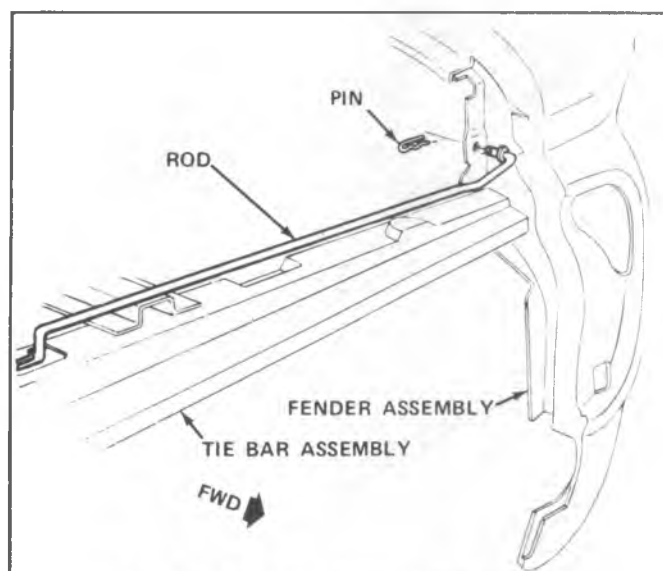

Fig. 2C-10--Hood Rod Support - G Model

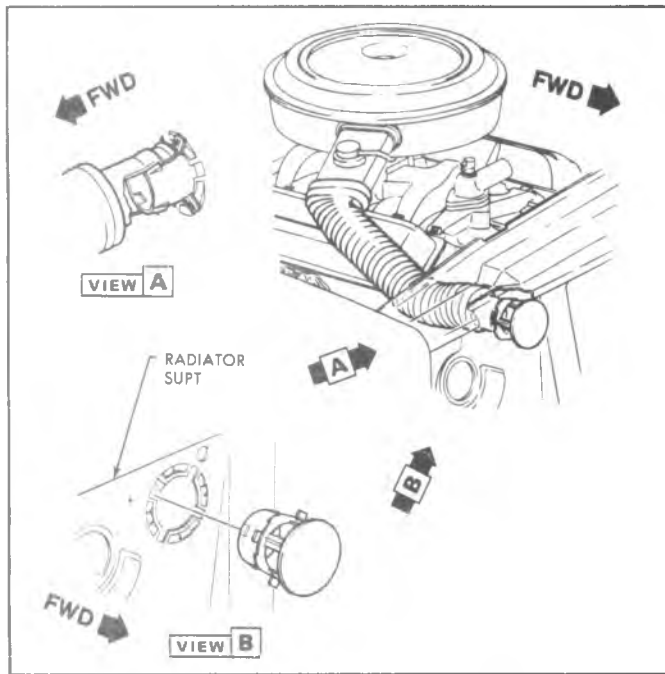

Fig. 2C-11--Typical Carburetor Air Inlet Snorkel - CK Model

**FRONT SHEET METAL - CK MODEL**

Shims which are found at various locations should be recorded to ease installation of sheet metal assembly.

**Removal**

1. Remove bolts at hood hinge and link. Remove hood assembly.

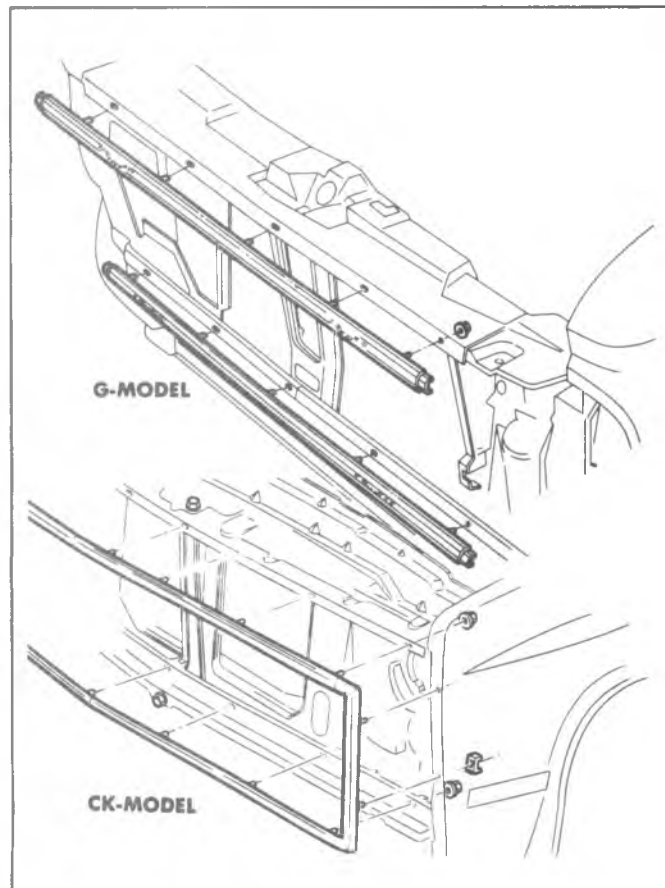

Fig. 2C-14-- Grille Moldings - CK, G Models

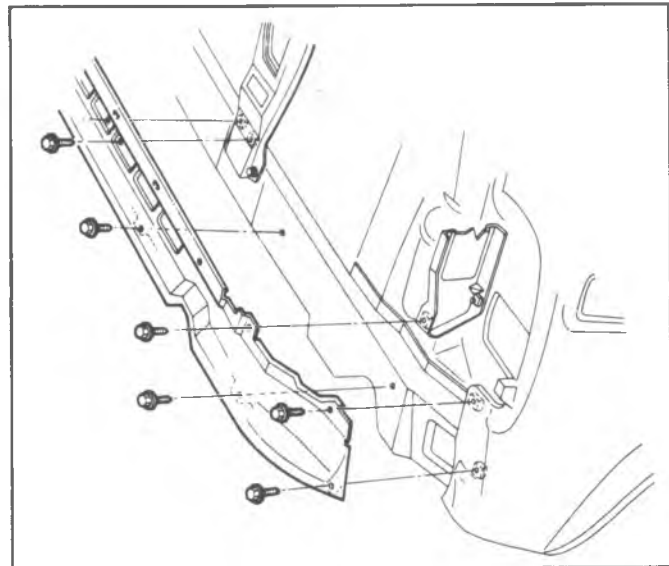

Fig. 2C-12--Lower Radiator Grille - G Models

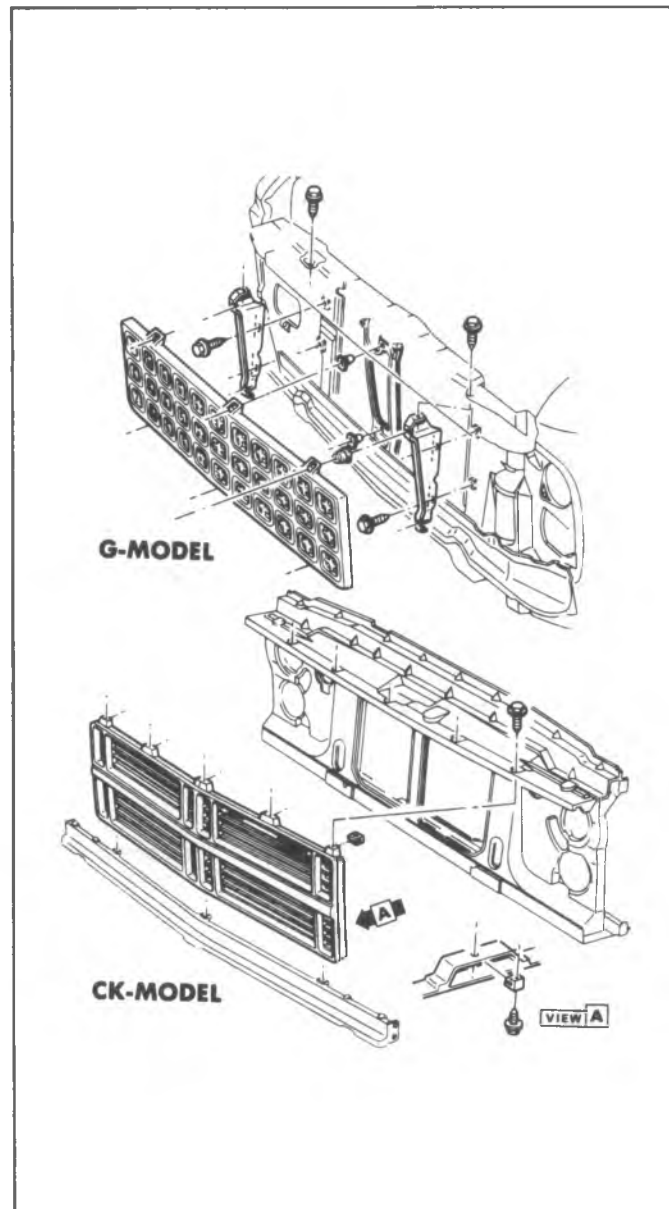

Fig. 2C-13--Grille Panel or Brackets

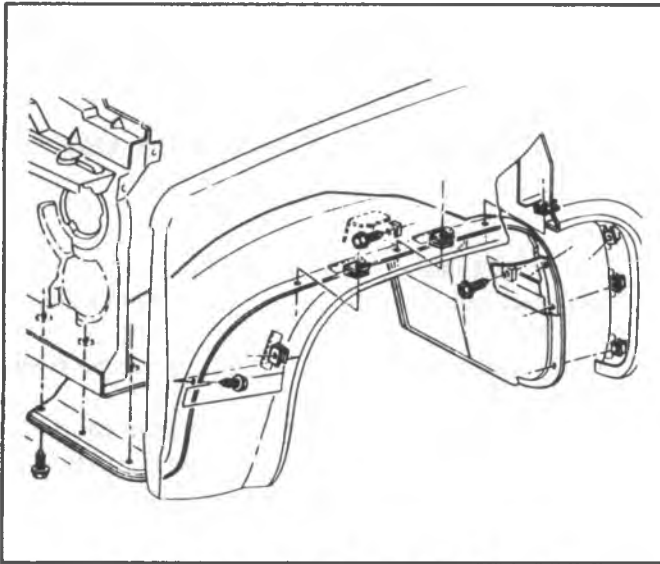

Fig. 2C-15—Fender Skirt Assembly-CK Model

2. Drain radiator and remove radiator hoses. Disconnect oil cooler lines if so equipped.
3. Disconnect wire connectors at the dash and toe panel and wire connector to horn and voltage regulator.
4. Disconnect battery and generator wires.
5. Remove front bumper bolts and remove bumper.
6. Remove bolts attaching fender upper edge to cowl door frame.
7. Remove fan shroud.
8. Working from underneath rear of fender, remove attachment from each fender at the hinge pillar.
9. Remove bolt from each radiator support mounting.
10. Remove bolts at each fender skirt to cab underbody (Fig. 2C-15).
11. With a helper, remove front sheet metal assembly, with radiator, battery, horn and voltage regulator attached.

#### Installation

1. With a helper place sheet metal assembly in position. Install all bolts loosely to facilitate aligning after complete installation.
2. Install fender bolts at cowl.
3. Install combination bolt and flat washer assembly into each fender reinforcement while inserting shims required between fender reinforcement and body (Refer to Fig. 2C-16).
4. Install two bolts and shims required at each fender rear lower edge to hinge pillar.
5. Install bolt in each fender skirt to underbody.
6. Install bolts at steering column skirt reinforcement, final torque 25 ft. lb. (33 N·m).
7. Tighten each radiator support mounting bolt 33 ft. lb. (44 N·m).
8. Torque bolts at fender to cowl 25 ft. lb. (33 N·m)
9. Install front bumper.
10. Connect wire connectors at dash and toe panel. Attach generator and regulator wires.

11. Connect upper and lower radiator hoses. Connect oil cooler lines to the radiator on models so equipped.
12. Connect battery and fill radiator. Start engine and check for leaks.
13. Install Hood.

#### Radiator Support

##### Removal

1. Drain radiator, saving coolant, loosen attachments and remove radiator and coolant recovery tank.
2. Disconnect and remove battery.
3. Remove wiring from radiator support.
4. Disconnect fan shroud and lay back on engine.
5. Remove both head lamp assemblies.
6. Remove grille assembly.
7. Remove lower radiator grille panel. (Fig. 2C-13).
8. Remove screws securing front fenders to radiator support.
9. Remove screws securing fender skirts to radiator support bottom. (Fig. 2C-15).
10. Remove bolt securing center support to radiator support.
11. Remove bolts securing hood latch assembly to radiator support.
12. Remove radiator support bolts secured to frame.
13. Tilt radiator support rearward and lift up and off.

##### Installation

1. Rotate radiator support into position and loosely install attachments to frame.
2. Connect center support to radiator support.
3. Connect hood latch plate.
4. Connect radiator support brackets to fenders.

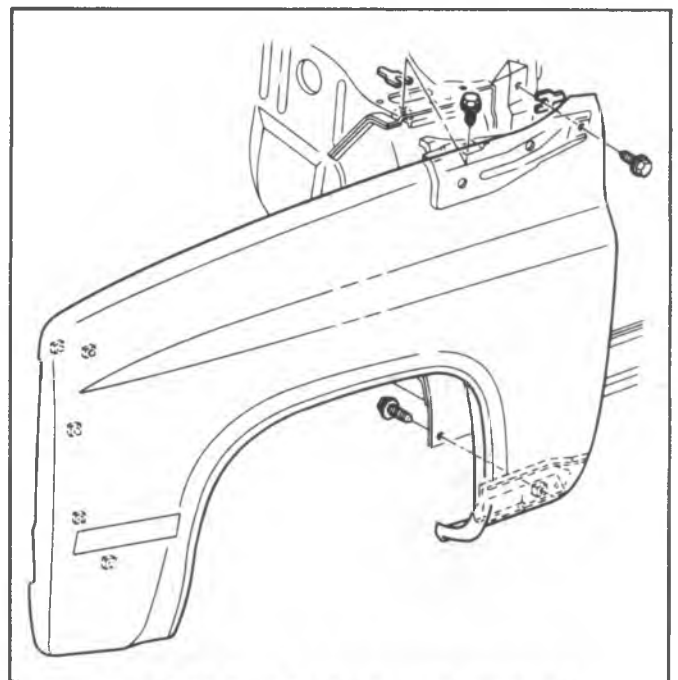

Fig. 2C-16—Front Fender Assembly-CK Model

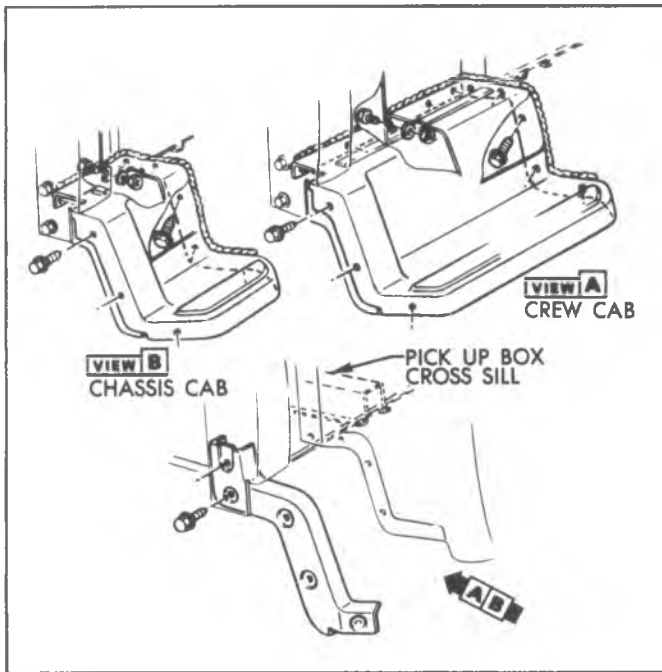

Fig. 2C-17--Running Boards-CK Models

5. Connect support to fenders.
6. Connect screws from underside of fender skirts to support bottom.
7. Attach grille lower panel to fenders.
8. Tighten radiator support bolts.
9. Install radiator coolant recovery tank hoses and shroud.
10. Connect removed wiring to radiator support.
11. Install both head lamp assemblies.
12. Tighten all previously installed bolts and screws.
13. Install battery and connect leads and wires.
14. Install grille assembly.
15. Fill radiator with coolant as specified in Section 6B.

## FRONT FENDER (FIG. 2C-16)

### Removal

1. Remove hood and hinge assembly.
2. Remove head lamp bezel, wiring and attachments from fender.
3. Remove screws attaching lower radiator grille panel.
4. Remove screws attaching fender wheel opening flange to skirt.
5. Remove skirt to fender bolts, located inboard on underside of skirt.
6. Remove two (2) screws attaching battery support bracket to fender.
7. Remove five (5) screws attaching radiator support to front fender.
8. Remove bolt and shim attaching trailing edge of fender to hinge pillar.
9. Remove two bolts and shims at top rear of fender attaching to cowl.

### Installation

To install, reverse the removal procedure using sealing tape between filler panel and fender. Check sheet metal alignment.

## FRONT FENDER AND SKIRT (FIGS. 2C-15 AND 2C-16)

### Removal

1. Remove hood and hood hinge assembly.
2. Disconnect and remove battery (right side or auxiliary left side).
3. Remove head lamp bezel, wiring and attachments from fender.
4. Remove screws attaching lower radiator grille panel.
5. Remove screws attaching skirt to radiator support.
6. Remove two (2) top rear fender bolts and shims.
7. Remove bolt and shims at bottom of fender.
8. Remove bolts attaching skirt to underbody.
9. Remove two (2) screw attaching support bracket to fender.
10. Remove five (5) screws attaching radiator support to front fender.
11. Lift fender and skirt from truck.

### Installation

Install front fender and skirt assembly in reverse order of removal.

## RUNNING BOARDS

Refer to Fig. 2C-17 for removal and installation of running boards.

### Fender Skirt - P Model

Refer to figure 2C-18 for removal and installation of fender skirt, brackets, rear supports and hangers.

## ADHESIVE BODY SIDE MOLDING

Body side moldings are attached to body panels with butyl adhesive tape. To insure a good molding replacement (new or old moldings), the panel surface should be warm (21 to 32°C or 70 to 90°F), clean and free of any wax or oily film residue. Two methods are listed for attaching loose molding ends and completely removed moldings.

### Molding End Loose

1. Wash affected area with detergent and water and wipe dry. Wipe panel and adhesive side of molding with clean naphtha or alcohol.
 

If molding has separated from adhesive backing (tape remains on body panel), do not remove tape from body. Clean back of molding and tape on body with naphtha or alcohol and proceed with step 3.
2. If needed, apply a length of masking tape as a molding guideline. A suitable straightedge may also be used in most cases.
3. Apply adhesive to back of molding and press in place.
  - a. If Loctite 414 adhesive (part no. 1052283) or equivalent is used, apply constant pressure to molding for 30 seconds or until a firm bond has been established.

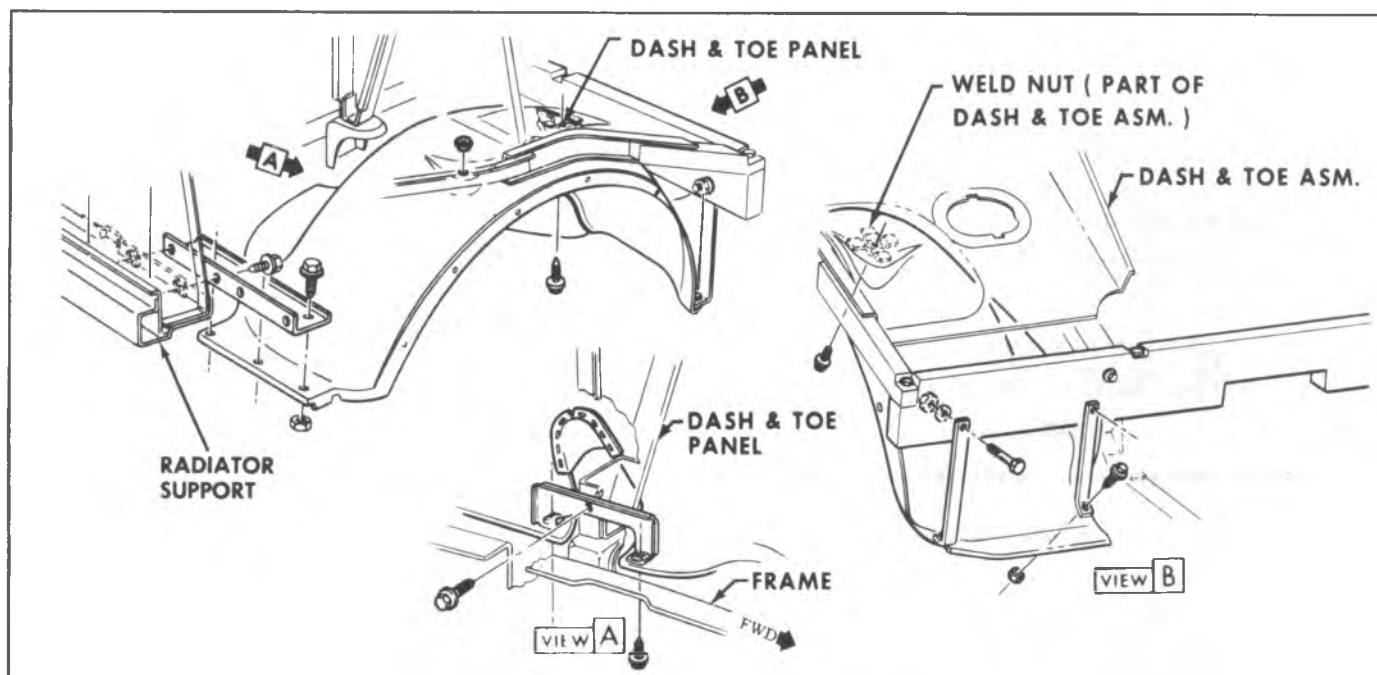

Fig. 2C-18--Fender Skirt, Dash and Toe Pan-P Series

- b. If 3M Super Weatherstrip Adhesive (or equivalent) is used, tape molding in place for 15 minutes. Use naphtha for clean-up.
- c. If 3M Plastic and Emblem Adhesive (or equivalent) is used, follow package instructions for apply adhesive and tape molding in place for 30 minutes.

#### Molding Completely Removed

1. Wash affected panel area with soap and water and wipe dry. Remove all traces of adhesive from body panel and back of molding using oil-free naphtha or alcohol.
2. Mark proper alignment position of molding with a length of masking tape. Use adjacent moldings as a guide, if applicable (view A, Fig. 2C-19.)
3. If body is below 70°F (21°C) due to shop temperature or prior outside temperature, warm body panel with heat lamp or heat gun while proceeding with step 4.
4. Apply 3M Neoprene Fame Tape, Part No. 06377 or 06378 or equivalent to molding.
5. Align molding to previously installed tape guideline and firmly press in place.

## WOOD GRAIN APPLIQUE

### General

The wood grain applique (transfer film) is a vinyl material with a pressure sensitive adhesive backing. The transfers are serviced in precut panels. The transfers are designed with an appealing wood grain pattern and a 50 degree or semigloss finish.

Preparation of the surface to which the transfer will be applied is very important. In cases where body metal repair has been made it is necessary to prime and color coat these areas to blend with the undamaged surface. Apply the transfer film to color coated panels only, never to bare metal or primer.

The surface must be free of any imperfections that might high-light through the film. Remove dirt nibs and other foreign material in the paint by light sanding with 600 grit sandpaper.

The temperature of the body must be maintained at a moderate level between approximately 70 and 90°F (21 and 32°C). Too warm a body will cause the wood grain film to stick prematurely while too cool a body will reduce the adhesion of the wood grain film. Cool the body panel with cool water when too warm and heat the body panel with a heat gun or a heat lamp when too cold.

Transfers should not be replaced in temperatures below 65 ° F (18°C). The transfer should not be subjected to temperature greater than 175°F (79°C) and should not be left at or near this temperature for extended periods of time.

Shelf life of the transfer material is 90 days at a temperature not to exceed 105°F (40°C).

### Removal

Remove the moldings from the affected panel. The transfer film may then be removed by lifting an edge and peeling the material from the painted surface. Exercise care so as not to damage the paint. Application of heat to the transfer and the panel by means of a heat gun or heat lamp will aid in the removal.

### Installation

1. With a solvent dampened sponge, clean entire surface to be covered with applique.
2. Wipe area dry with a clean cloth.
3. Prior to application of transfer, wet down the complete transfer surface of the fender with a solution of 1/4 oz. of neutral detergent cleaner (must not contain oils, perfumes, or bleaches) per gallon of clear water. It is essential that no substitute for this solution be used and that the specified proportions be maintained.
4. While entire area is still wet with solution, remove paper backing from transfer and align upper



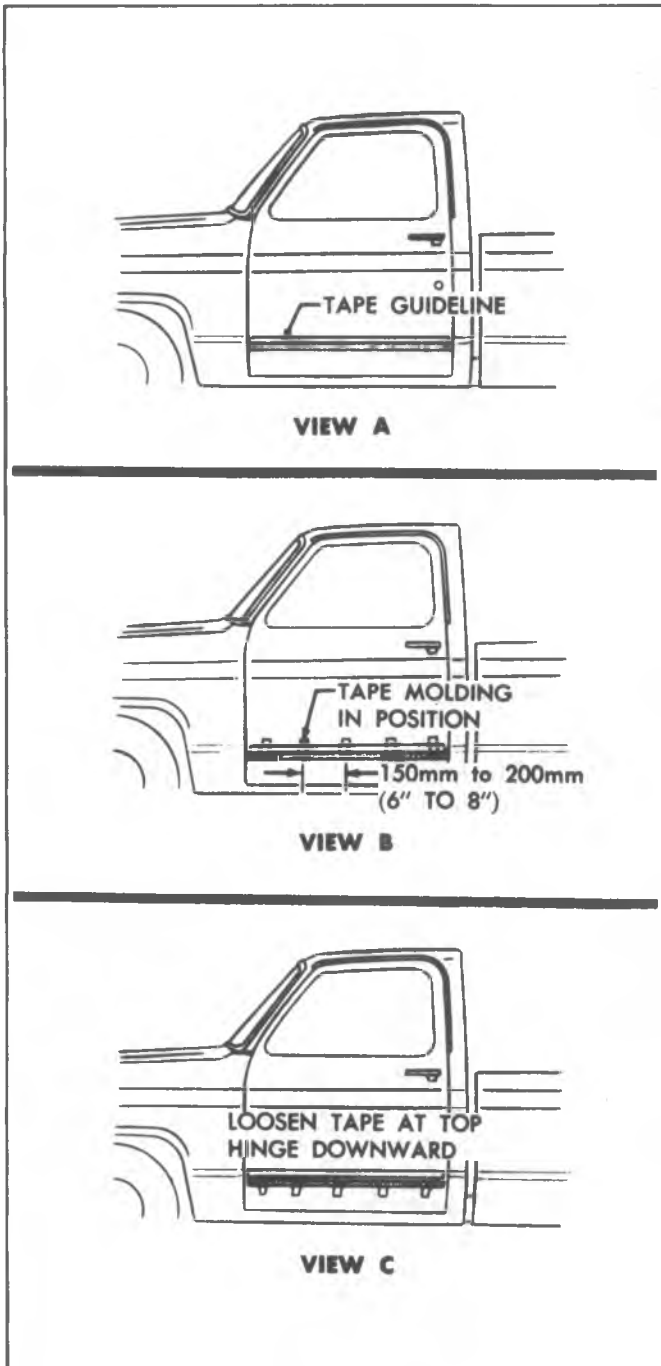

Fig. 2C-19--Molding Application

edge with pierced holes in fender and press on lightly.

5. Start at center of transfer and squeeze outboard from middle to edges removing all air bubbles and wetting solution to assure a satisfactory bond. Use teflon-backed plastic squeegee only.
6. Notch applique at fender rear contour bend areas with scissors. Also notch out front marker lamp.
7. Fold ends of applique over fender flanges using squeegee. Heat the wrap-around area of applique with a heat lamp or gun to approximately 90°F (32°C) and press with squeegee to secure entire edge surface.
8. If the wrap-around of the transfer has trouble sticking to fender edges, brush vinyl adhesive onto the fender or

transfer area. Allow the adhesive to set for one minute then press transfer to fender for adhesion.

9. Inspect transfer installation from critical angle using adequate light reflection to detect any irregularities that may have developed during installation. Remove all air or moisture bubbles by piercing each at an acute angle with a fine pin or needle and by pressing the bubble down.
10. Install previously removed parts and clean up vehicle as required.

### DECAL APPLICATION PROCEDURE (ALL VEHICLES)

1. Wipe clean the entire fender surface, body surface, door jam flanges, door facings, fender flanges, etc, to be covered with the transfer with a sponge dampened with Naptha or equivalent.
2. Wipe cleaned surface dry with clean cloth.
3. Starting with front fender, cut stripe to length. Allow excess at ends if necessary to avoid handling ends of stripe with fingers. Trim excess before wrapping around or tucking ends.
4. Remove about 6.00 in. (152.4mm) of the paper backing from stripe and align stripe on vehicle. Fender stripe should bridge the gap at the fender extension, be tucked in with the edge of the squeegee and then trimmed with a razor blade.
5. Pressurize stripe with a soft squeegee or a felt pad. Do not use thumbs or fingers as adequate pressure cannot be applied.
6. Remove the decal backing about 12.00 in. (304.8mm) at a time careful not to touch adhesive with fingers and repeat step no. 5.
7. After complete pressurization, remove the protective premask from the stripes at 180° angle.
8. Repeat above steps no. 4 thru 7 for the doors, quarter panels, and end caps.
9. Fold material around wrap areas, pressurize, heat to approximately 90°F (32°C) with heat gun, and repressurize.
10. Heat all areas at ends of stripes (end caps, front of fender, rear of quarter panel, etc.)
11. Reinspect entire stripe, especially ends and wraps and re-pressurize and heat where necessary to insure entire stripe is down.
12. Best results are obtained when metal temperature is 70°90°F (21°32°C). Use heat gun or allow cooling time when metal is outside approximate temperature range.
13. The maximum temperature that the tape should be subjected to is 175°F (79°C) (paint repair oven temperature). No tape stripe job should be left in a paint repair oven as damage to the tape may occur.
14. The tape will not be affected by any of the cleaning solvents, waxes or detergents now being used at the assembly plants. Acrylic lacquer solvents will affect the clear coating over the vinyl.
15. This tape stripe highlights metal imperfections so that all dings and rough metal must be repaired before applying the tape.
16. If after application of stripes, there appears to be bubbles in the surface of the tape stripes,



piercing them with an ordinary safety pin will relieve the en- trapped air so that the bubble can be smoothed out.

17. Shelf life of the vinyl tape is 90 days at a maximum temperature of 105°F (40°C).

#### REPAIR

Repair is required when:

1. If the tape is damaged.
2. The paint is damaged as the tape is pulled back for realignment or releasing trapped air.

The following repair procedure is recommended:

1. If the tape is ruined with no paint being removed, the surface should be wiped with a prep-sol to insure a smooth and clean surface. Another section of tape would then be applied according to the application procedure.
2. If a section of paint is removed when the tape is pulled away, the area must be repainted and feathered into the adjoining surfaces. Another section of tape should be applied according to the application procedure.

#### REMOVAL

Removal of decal should cause it to be permanently damaged. Test to be conducted at an ambient temperature not to exceed 90°F (32°C) and after a minimum of 72 hours aging.

#### For Large Decals

1. Prior to application of transfer, wet down the complete transfer surface with a solution of 0.25 oz. of neutral detergent cleaner (must not contain oils, perfumes, or bleaches) per gallon of clear water. It is essential that no substitute for this solution be used and that the specified proportions be maintained.
2. While entire area is still wet with solution, remove paper backing from transfer, locate and press on lightly.
3. Start at center of transfer and squeegee outboard from middle to edges, removing all air bubbles and wetting solution to assure a satisfactory bond. Use teflon-backed plastic squeegee only.

### TORQUE SPECIFICATIONS

|                                | CK                     | G                      |
|--------------------------------|------------------------|------------------------|
| Lock to Bracket & Rad. Support | 27 N·m ( 20 ft. lbs. ) |                        |
| Lock Support to Hood           |                        | 17 N·m (150 in. lbs. ) |
| Lock Bolt Nut                  |                        | 54 N·m ( 40 ft. lbs. ) |
| Bumper Bolt Nut                |                        | 17 N·m (150 in. lbs. ) |
| Hood Hinge                     | 24 N·m ( 18 ft. lbs. ) | 24 N·m ( 18 ft. lbs. ) |
| Hood Lock Catch                | 27 N·m ( 20 ft. lbs. ) | 24 N·m ( 18 ft. lbs. ) |
| Lock Support to Rad. Support   | 17 N·m (150 in. lbs. ) | 24 N·m ( 18 ft. lbs. ) |
| Rad. Support to Frame          | 48 N·m ( 35 ft. lbs. ) |                        |
| Rad. Support to Fender         | 17 N·m (150 in. lbs. ) |                        |
| Fender Skirt to Fender         | 17 N·m (150 in. lbs. ) |                        |
| Fender to Cowl                 | 48 N·m ( 35 ft. lbs. ) |                        |
| Rad. Grille Panel Lower        | 17 N·m (150 in. lbs. ) |                        |



## SECTION 2D

# CAB AND BODY

**NOTICE** Fasteners are important attaching parts in that they could affect the performance of vital components and systems, and/or could result in major repair expense. They must be replaced with one of the same part number or with an equivalent part if replacement becomes necessary. Do not use a replacement part of lesser quality or substitute design. Torque valves must be used as specified during reassembly to assure proper retention of these parts. For prevailing torque nut(s) and bolt(s), refer to the "Reuse of Prevailing Torque Nut(s) and Bolt(s)" chart in Section 10.

### CONTENTS OF THIS SECTION

|                           |       |
|---------------------------|-------|
| General Description ..... | 2D-1  |
| On Vehicle Service        |       |
| C-K Models .....          | 2D-4  |
| G Models .....            | 2D-38 |
| Specifications .....      | 2D-63 |
| Special Tools .....       | 2D-65 |

## GENERAL DESCRIPTION

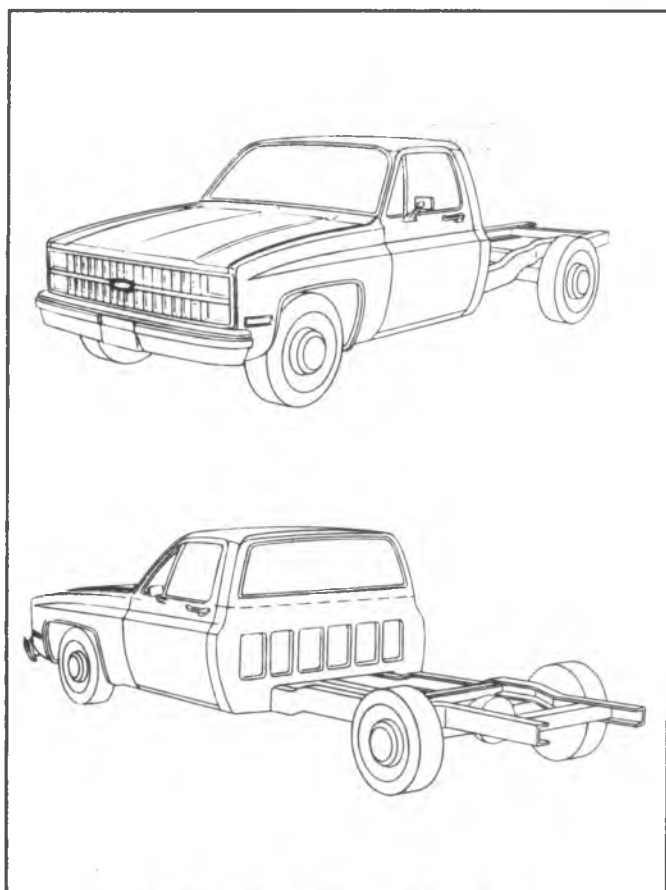

Fig. 2D-1--Typical Chassis/Cab Model

On the following pages, service procedures will be given for components on all 10-20-30 series trucks in C, K and G models. Reference will be made, both in text and

illustrations, to vehicle model lines and to individual model numbers within these model lines.

As an aid to identification of specific models, the following general descriptions are given.

#### **Chassis/Cabs**

Chassis cab models see figure 2D-1. Two-wheel drive units come in C10, C-20 and C-30 series. Four-wheel drive units may be either K-10 or K-20. Optional pickup boxes are available.

#### **Crew Cab/Chassis**

Crew cab/chassis models see figure 2D-2. Optional pickup boxes are available.

#### **Suburban**

Suburban model see figure 2D-3. Base models have rear cargo doors. An optional endgate with moveable window is available.

#### **Utility**

Utility vehicle models see figure 2D-4. Are available with a removable roof or a convertible roof.

#### **Vans**

G-Series Vans are available in three models See figures 2D-5 and 2D-6. Vans without body windows and/or passenger seats, sport vans with body windows and passenger seats and commercial cutaway vans as shown in figure 2D-6.

#### **Anti-Corrosion Information**

"Anti-corrosion materials have been applied to the interior surfaces of some metal panels to provide rust resistance. When servicing these panels, areas on which this material has been disturbed should be properly recoated with service-type anti-corrosion material."

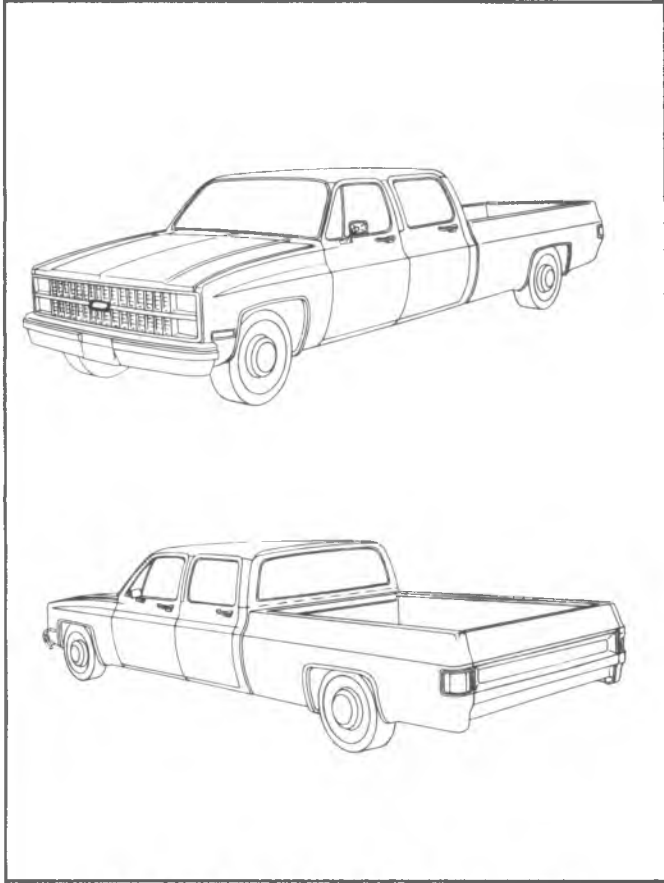

Fig. 2D-2--Typical Crew Cab/Chassis Model



Fig. 2D-3--Typical Suburban Model

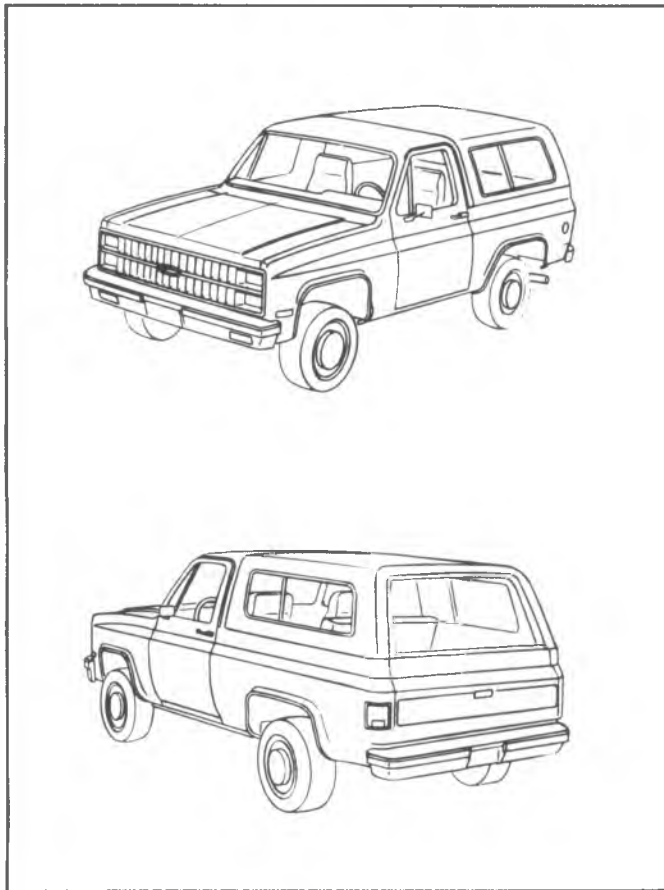

Fig. 2D-4--Typical Utility Vehicle Model

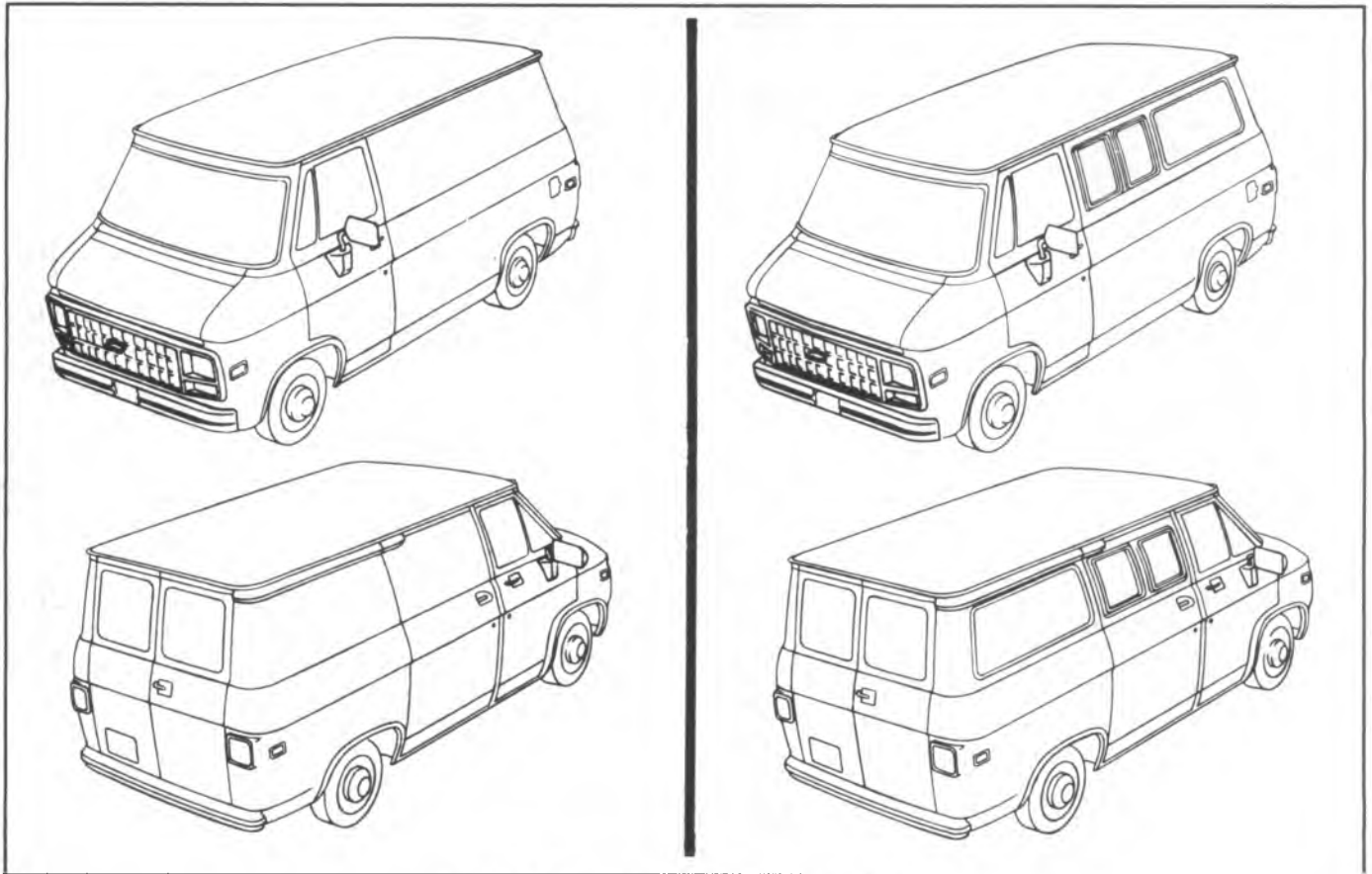

Fig. 2D-5--Typical Vans and Sport Vans Models

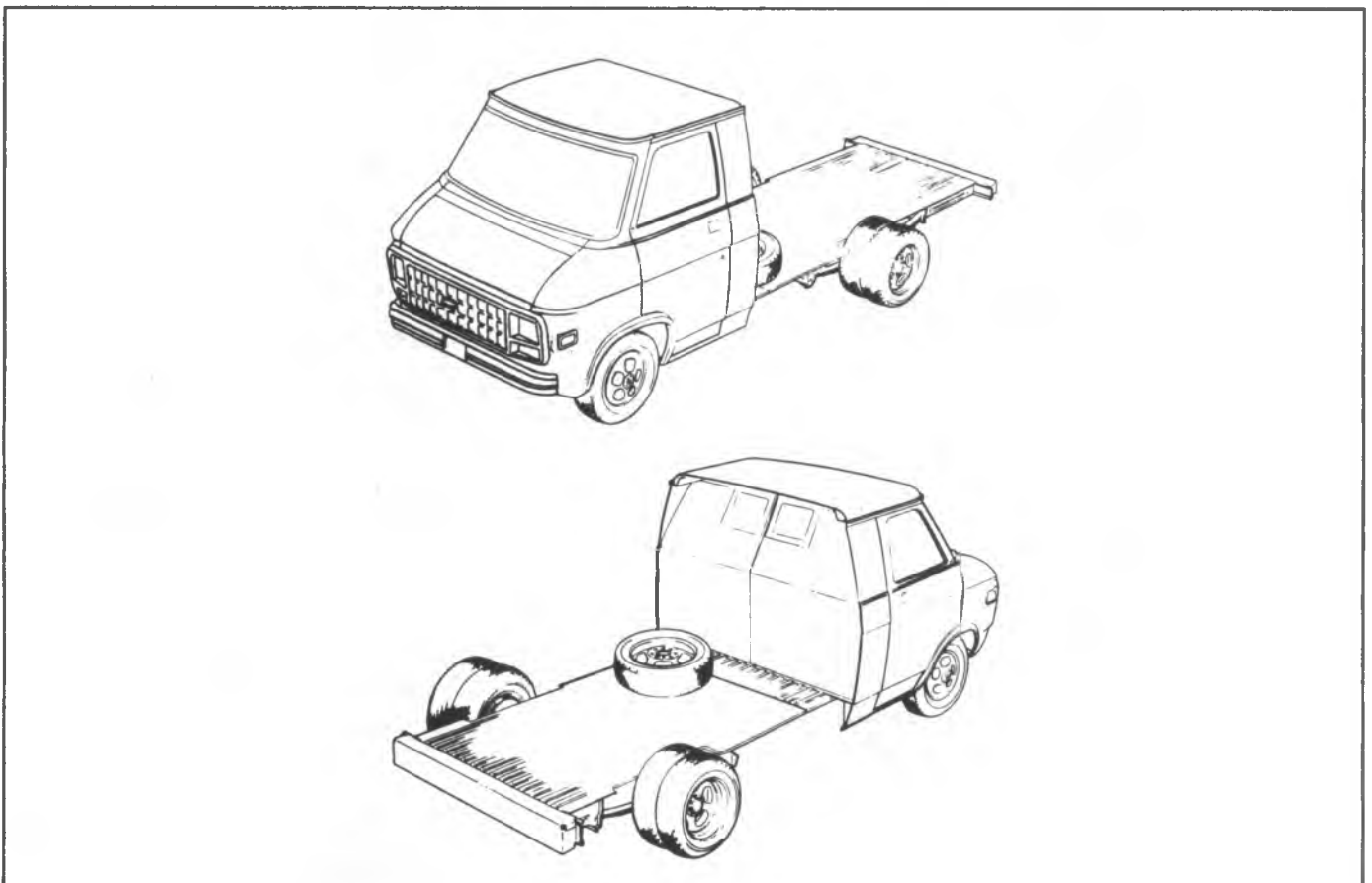

Fig. 2D-6--Typical Commercial Cutaway Model Van

## ON VEHICLE SERVICE

### C-K MODELS

#### INDEX

|                       |       |                             |       |
|-----------------------|-------|-----------------------------|-------|
| Front End             |       |                             |       |
| Windshield Wipers     | 2D-4  | Hinges                      | 2D-15 |
| Glove Box             | 2D-5  | Stationary Glass            | 2D-15 |
| Rear View Mirrors     | 2D-5  | Window and Regulator        | 2D-17 |
| Body Glass            |       | Locks, Handles, Rods        | 2D-17 |
| Windshield Glass      | 2D-6  | Weatherstrip                | 2D-18 |
| Stationary Body Glass | 2D-9  | Rear Doors                  |       |
| Doors                 |       | Adjustments                 | 2D-18 |
| Adjustments           | 2D-9  | Locks, Handles, Rods        | 2D-18 |
| Front Side Door       | 2D-10 | Hinges                      | 2D-18 |
| Replacement           | 2D-10 | Endgates                    | 2D-20 |
| Hinges                | 2D-10 | Tailgates                   | 2D-26 |
| Ventilator            | 2D-11 | Removable Top (Utility)     | 2D-27 |
| Window and Regulator  | 2D-12 | Seat Belts                  | 2D-29 |
| Locks, Handles, Rods  | 2D-14 | Seats                       | 2D-29 |
| Weatherstrip          | 2D-15 | Body Mounting               | 2D-30 |
| Rear Side Doors       | 2D-15 | Appique Procedures          | 2D-30 |
| Replacement           | 2D-15 | Adhesive Body Side Moldings | 2D-30 |

### FRONT END

Pull outer end of arm away from glass which will trip lock spring at base of arm and release spring from undercut of pivot shaft. While holding arm in this position, pull outward on cap section at base of arm to remove arm. Arm can be reinstalled in any one of several positions due to serrations on pivot shaft and in arm cap. See figure 2D-7.

#### Wiper Arm Pivot Shafts and Linkage

##### Removal

1. Remove windshield wiper arms from pivot shafts. Procedure for removing arms is explained previously under "Arm Adjustment".
2. Remove cowl ventilator grille.
3. Remove two nut and lock washer assemblies from the connector link to motor drive arm via the plenum access hole.
4. Remove two screws from each transmission pivot shaft assembly to windshield frame. Remove wiper linkage and transmission from plenum.

##### Installation

1. Place wiper linkage and transmission into position. Secure assembly with two screws at each transmission.
2. Attach end of cross rod to drive arm of motor assembly. Secure rod.
3. Before installing wiper arms or cowl ventilator grille, operate wiper motor momentarily which should rotate pivot shafts to park position.
4. Install arms, grille and shafts.

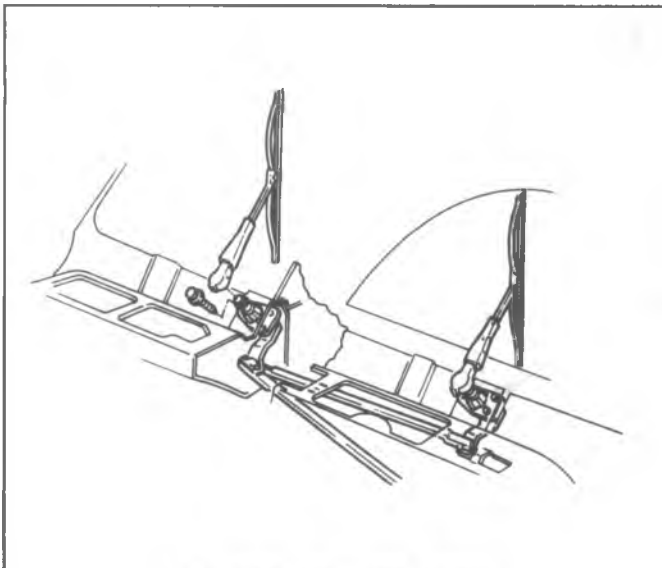

Fig. 2D-7--Windshield Wipers

### WINDSHIELD WIPERS

Windshield wiper units on all models are of the two-speed electric type. A single wiper motor unit, mounted to the left side of the dash panel inside the engine compartment, powers both wiper arms. The wiper arm operating link rods and pivot mountings on these models are located in the outside air inlet plenum chamber.

#### Arm Adjustment

To adjust sweep of blades, turn on wipers and note sweep of arms. If necessary, remove one or both arms as follows:

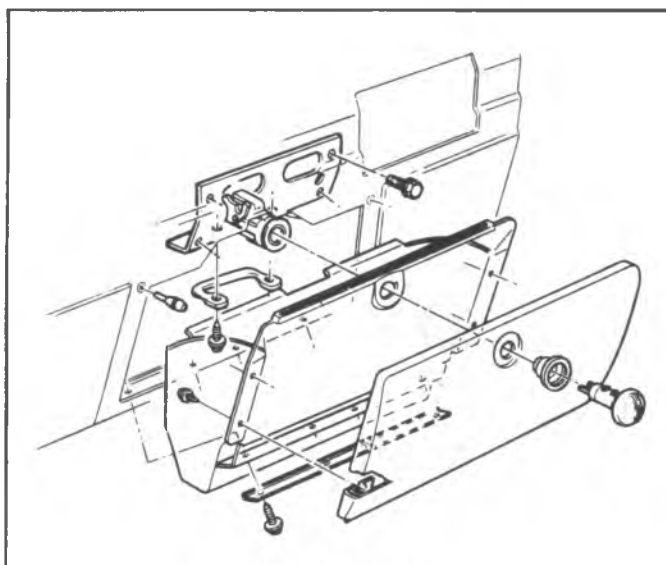

Fig. 2D-8--Glove Box

### INSTRUMENT PANEL COMPARTMENT AND LOCK

#### Replacement

Removal of the entire assembly including door may be accomplished by removing four screws which attach hinge just below box. See figure 2D-8. The outer door panel may be removed, leaving the compartment intact, by removal of four screws. Access to the door stop bumper is gained by reaching into compartment opening with door partially open.

#### Adjustment

Engagement of lock in striker may be adjusted by loosening striker retaining screws and moving the striker to desired position.

### OUTSIDE REAR VIEW MIRRORS

Rear view mirror installations are shown in figure 2D-9, 2D-10 and 2D-11. Occasional tightening of mounting and assembly bolts and screws will sharply decrease occurrence of failure due to door slamming or road shock.

Camper mirror installation is similar to the below eyeline mirror installation.

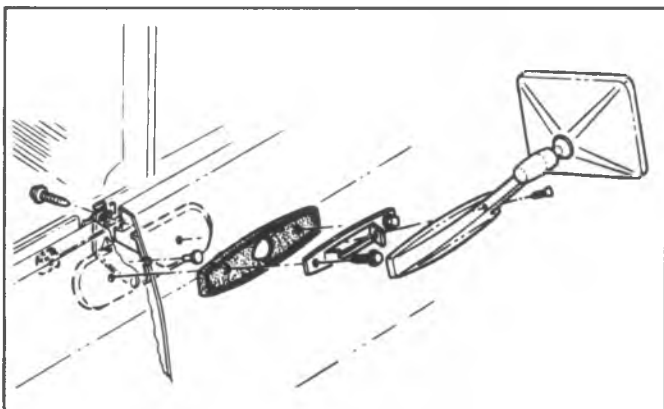

Fig. 2D-9--Rear View Mirror - Base

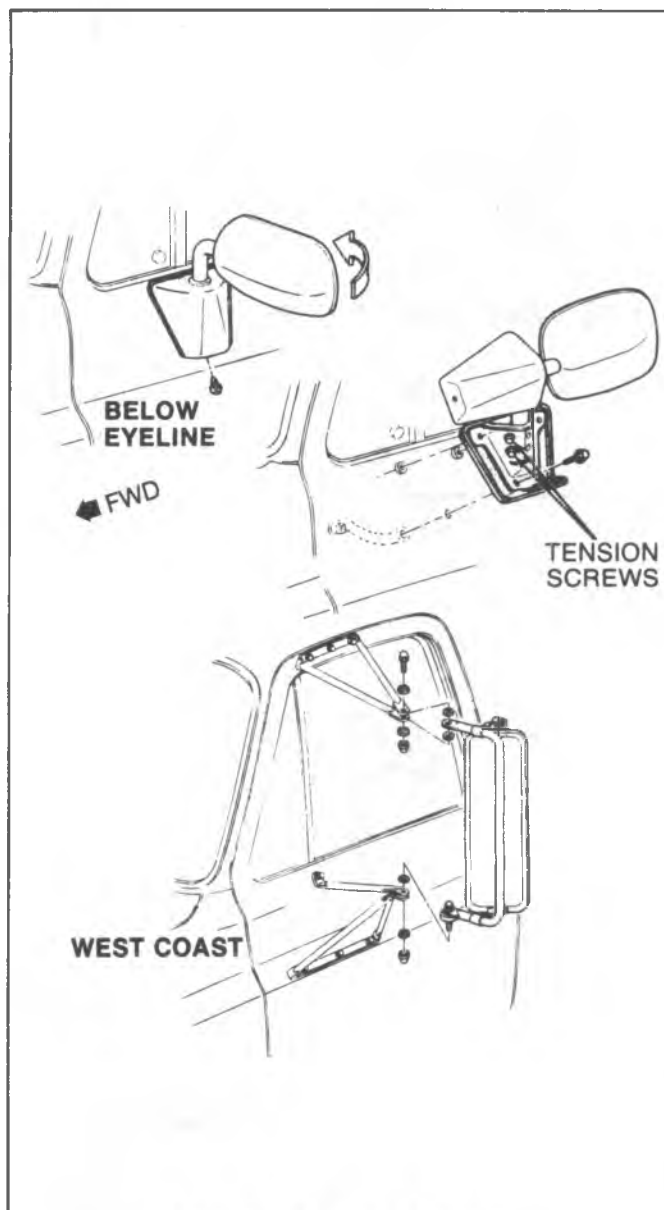

Fig. 2D-10--Rear View Mirrors

**INSIDE REAR VIEW MIRROR - FIGURE 2D-11****Replacement**

1. Remove screw retaining mirror to its glass-mounted bracket and remove mirror.
2. Install mirror into its mounting bracket. Torque screw to specifications.

**COWL VENT VALVE - FIGURE 2D-12**

Two styles are shown in Figure 2D-12. Removing the attaching screws allows removal of the valve from the side panels.

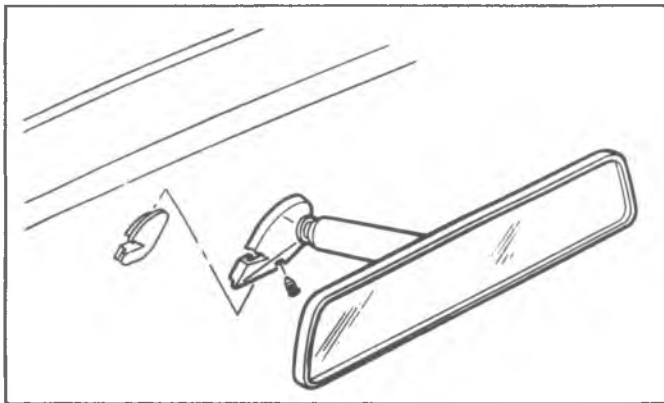

Fig. 2D-11--Inside Rear View Mirror

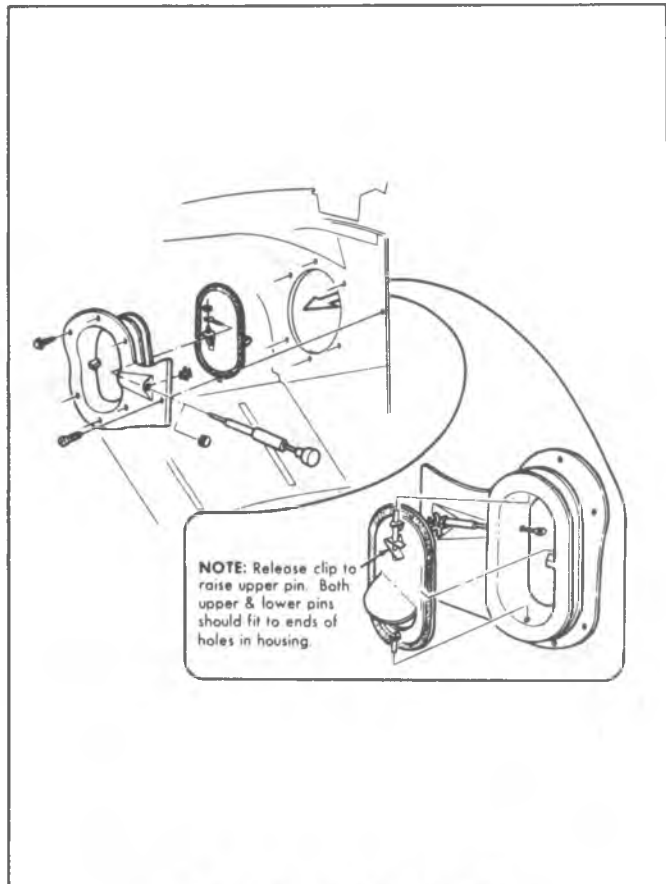

Fig. 2D-12--Cowl Vent Valves

**BODY GLASS**

**CAUTION:** Always wear gloves and eye glasses when handling glass to avoid personal injury.

**CK TRUCK WINDSHIELD REPLACEMENT**

The windshield is a one-piece type and is retained in the windshield opening by a urethane bonded rubber weatherstrip. See figure 2D-13.

When replacing a cracked windshield glass, it is very important that the cause of the glass breakage be determined and the condition corrected before a new glass is installed. Otherwise, it is highly possible that a small obstruction or high spot somewhere around the windshield opening will continue to crack or break the newly installed windshield especially when the strain on the glass caused by this obstruction is increased by such conditions as wind pressures, extremes of temperature, motion of the vehicle, etc.

To replace a window installed with urethane adhesive requires replacement of the adhesive material. Adhesive service kits No. 1052420 and No. 9631000 contain some of the materials needed to remove and replace a urethane adhesive installed glass. These kits and other materials that may be required can be obtained through the service parts system. The components of glass adhesive kits (urethane) No. 1052420 and 9631000 are as follows:

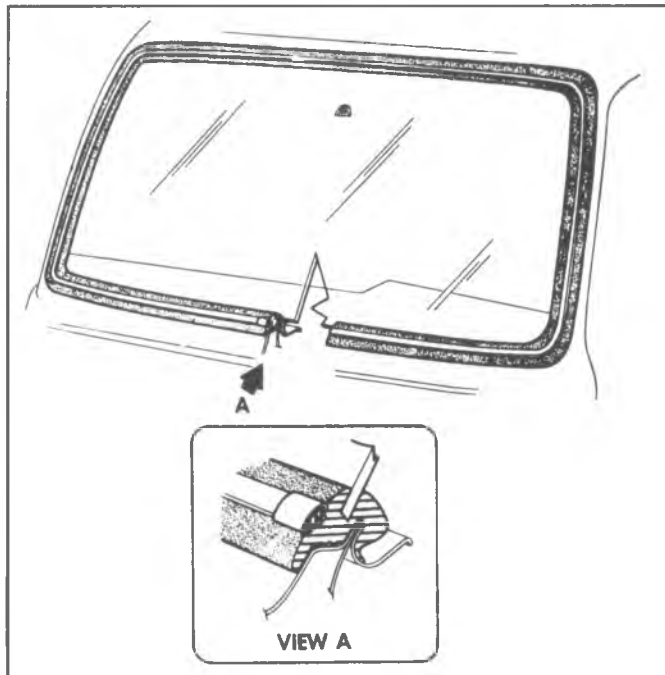

Fig. 2D-13--Typical Windshield



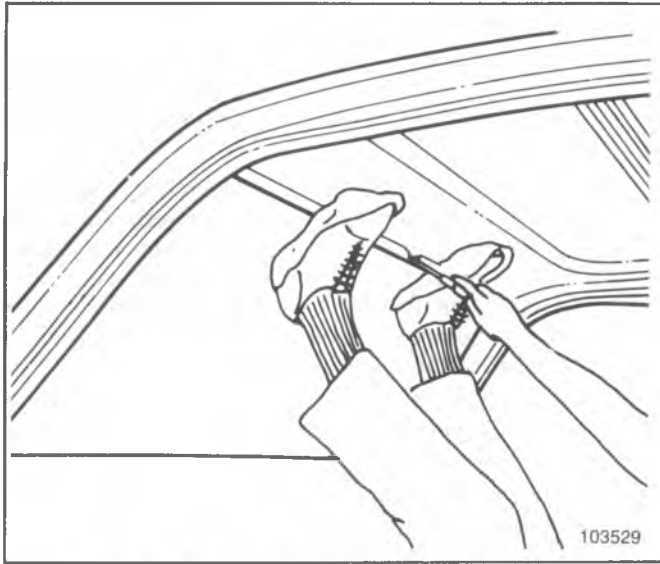

Fig. 2D-14--Applying Pressure to Windshield

1. One tube of urethane adhesive material.
2. One dispensing nozzle.
3. Steel music wire.
4. Rubber cleaner.
5. Rubber primer.
6. Pinch-weld primer.
7. Blackout primer.
8. Filler strip (for use on windshield installations on vehicles equipped with embedded windshield antenna).
9. Primer applicators.

#### Additional Material Required:

1. Rubber lubricant No. 1051717 (available through the service parts system).
2. Alcohol for cleaning edge of glass.
3. Adhesive dispensing gun No. J-24811 or a standard household cartridge type gun reworked as follows:
  - a. Widen end slot to accept dispensing end of adhesive material tube.
  - b. Reduce diameter of plunger disc on rod so that disc can enter large end of adhesive material tube.
4. Commercial type razor knife (for cutting around edge of glass).
5. Weatherstrip tool set J-2189.
6. Six glass spacers J-22577 (for checking windshield glass to opening).

#### Removal

1. Before removing the windshield, mark the location of the break on the windshield rubber channel and the body. Protect the paint finish inside of the cab. Mask around the windshield opening and outside, lay a suitable covering across the hood and fenders.
2. Remove windshield reveal molding (lock strip) and reveal molding cap.
3. To free windshield rubber channel of weatherstrip loosen the lip of the windshield weatherstrip from the pinchweld flange along the top and at the sides by

applying firm, controlled pressure to the edge of the glass. At the same time assist the lip of the rubber weatherstrip channel over the pinchweld flange with a flat bladed tool. See figures 2D-14 and 2D-15.

4. With the aid of an assistant outside the cab, remove the windshield from the opening. See figure 2D-16.
5. Remove all excess urethane adhesive and any remaining pieces of weatherstrip from pinch-weld flange.
6. If sheet metal and paint repairs are required, refer to "Repairing and Refinishing Pinchweld Flange" of this section.

#### Checking Windshield Opening

Due to the expanse and contour of the windshield it is imperative in the event of a stress crack that the windshield opening be thoroughly checked before installing a replacement windshield. The replacement glass is used as a template.

1. Check for the following conditions at the previously marked point of fracture.
  - a. Chipped edges on glass.
  - b. Irregularities in body opening.
  - c. Irregularities in rubber channel weatherstrip.
2. Check flange area for solder, weld high spots, or hardened spot-weld sealer. Remove all high spots.
3. Check windshield glass to opening, by supporting glass with six spacers contained in packet J-22577. See figure 2D-17.

**NOTICE:** Do not strike glass against body metal. Chipped edges on the glass can lead to future breaks.

4. With the windshield supported and centered in its opening, check the relationship of the glass to the body opening flange around the entire perimeter of the glass.
5. Check the relationship of glass to opening as follows:
  - a. Inside edge of glass to body flange.
  - b. Outer edge of glass to parallel body metal.
6. Mark areas of body metal or flange to be reformed. Remove glass and correct as outlined in this section.

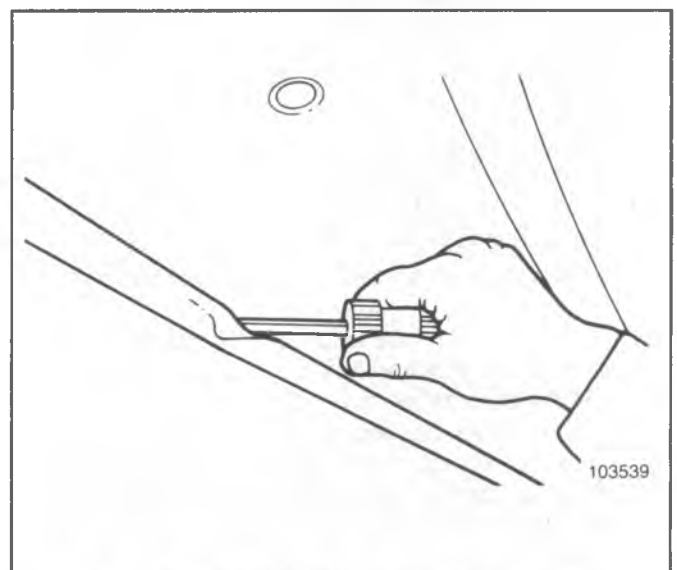

Fig. 2D-15--Assisting Weatherstrip over Flange

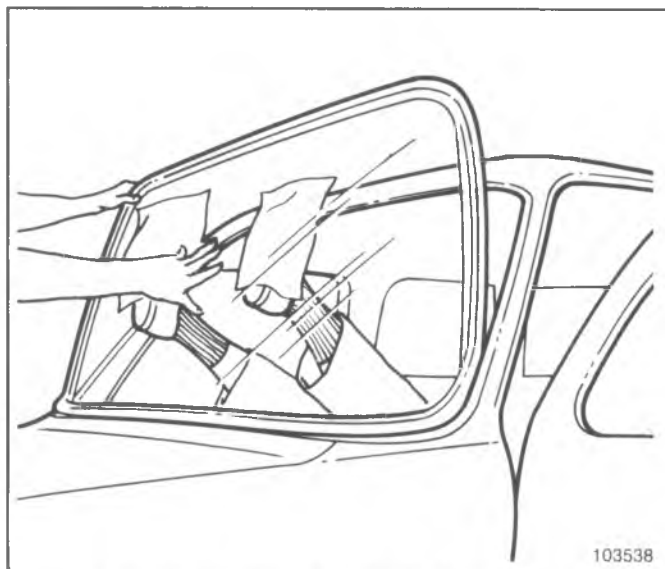

Fig. 2D-16--Removing Windshield from Opening

7. Recheck windshield in its opening and if satisfactory proceed as follows:

### Repairing and Refinishing Pinch-Weld Flange and/or Surrounding Areas

1. Repair all metal deformations in the windshield opening area for appearance.
2. Sand to smooth surface using No. 320 sandpaper.
3. Apply primer - surfacer (DuPont 80 S Primer - Surfacer, PPG 204-1000 Red Flash Primer or PPG 700-345 - Repair Primer/or equivalent) and sand smooth for required surface.
4. Apply color coats of 9984024 acrylic enamel (or equivalent) catalyzed as indicated.

### Installation (Fig. 2D-18)

Installation of the windshield requires a number of timed (cure time) steps. This timing is important and must be followed. All cure times are minimum, unless indicated otherwise. When performing a step that requires a cure time, it is not necessary to stop and wait for the cure time to elapse. Make a note of the cure time and move on to any following step that does not interfere with the timed sequence.

1. Wipe pinch-weld clean with a dry cloth. Make sure most of the previous urethane has been removed.
2. Apply pinch-weld primer with a new applicator to pinch-weld as shown in View B.

Primer must be thoroughly stirred and agitated prior to application.

Allow primer to cure for at least 30 minutes (100 hour maximum). Pinch weld flange must not exceed 160°F (38°C) at time of primer application.

3. Apply rubber cleaner with a new applicator to both channels of rubber weatherstrip as shown in View A. Allow cleaner to remain for at least 5 minutes (4 hour maximum), then wipe both channels with a clean dry cloth.
4. Apply rubber primer to both channels of rubber weatherstrip that were cleaned in the previous step and

are shown in View A. Allow primer to cure for at least 30 minutes (30 day maximum).

5. Thoroughly clean surface of glass to which blackout primer will be applied (around edge of inside surface) by wiping with a clean, alcohol dampened cloth. Allow to air dry.

**NOTICE:** When cleaning windshield glass, avoid contacting edge of plastic laminate material (on edge of glass) with volatile cleaner. Contact may cause discoloration and deterioration of plastic laminate by wicking action. **DO NOT** use a petroleum base solvent such as kerosene or gasoline. The presence of oil will prevent adhesion of new material.

6. Apply blackout primer to the same area of the windshield glass that was cleaned in the previous step and is shown in View C. Allow to dry to touch.
7. Apply a 3/16 inch minimum diameter bead of urethane adhesive around pinch-weld flange as shown in View B. Windshield glass must be installed within 20 minutes after performing this step.
8. Apply a mist of plain water to the urethane bead on the pinch-weld flange, wetting it fully.
9. Install rubber weatherstrip to the pinch-weld flange.
10. Apply a 3/16 inch minimum diameter bead of urethane adhesive to rubber weatherstrip glass channel as shown in View D.
11. Apply a mist of lubricant to surface "C" or weatherstrip as shown in View D, wetting it fully. Install windshield within 5 minutes after performing this step.
12. On windshields equipped with embedded antenna, tape pigtail of antenna to inside surface of windshield glass in a convenient and accessible position.
13. With the aid of a helper, lift glass into window opening. Suction cups may be used but are not mandatory. Then, install glass in channel of weatherstrip.
14. Apply lubricant to lockstrip channel. Windshield must be seated prior to application of lubricant.

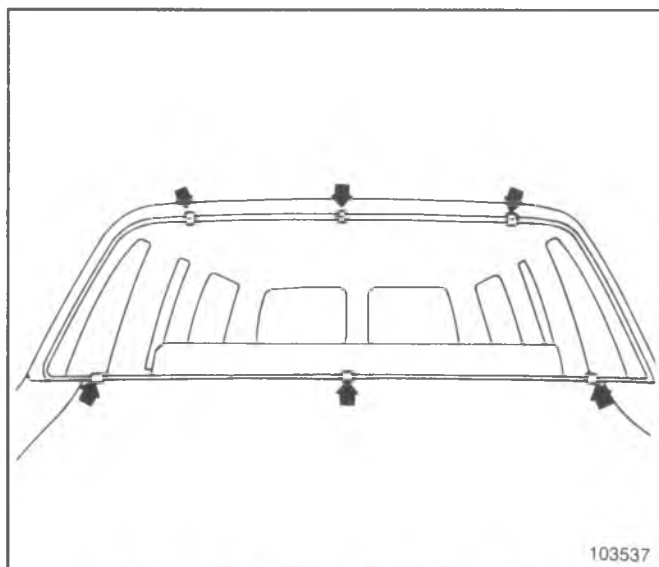

Fig. 2D-17--Checking Windshield Opening

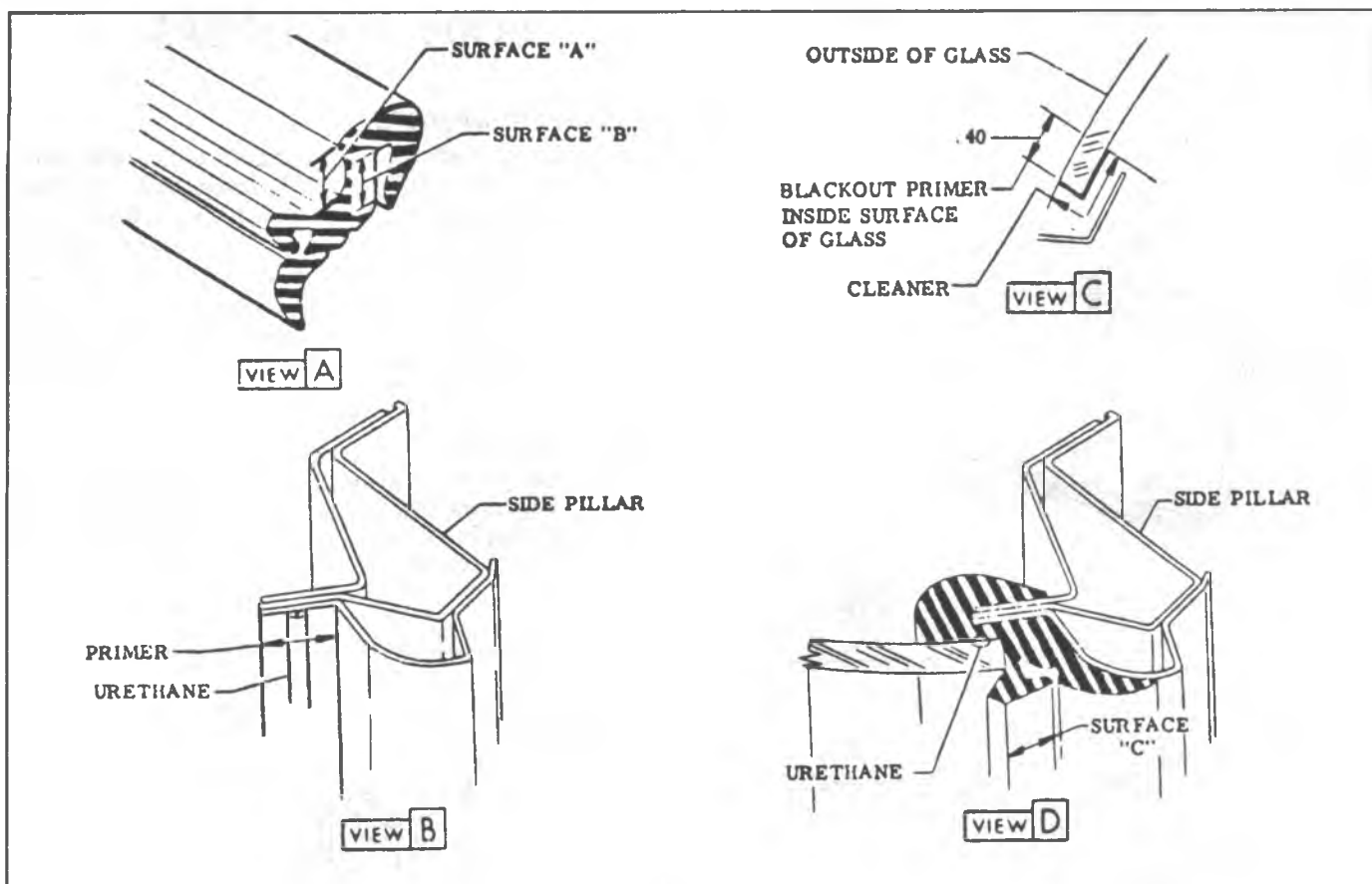

Fig. 2D-18--Windshield Installation-CK Truck

15. Use J-2189 weatherstrip tool set and install lockstrip in channel of weatherstrip. Install lockstrip cap at lockstrip joint.
16. Install windshield wiper arms and blades.
17. On windshields equipped with embedded antenna, connect antenna pigtail to radio antenna lead.
18. Install inside trim panels.
19. Install rear view mirror to windshield.

### STATIONARY BODY GLASS

#### Replacement

The method used to remove the windshield glass may be applied to other stationary glass, such as shown in figures 2D-20 and 2D-21. Remember to check for cause of breakage, and to always wear gloves when handling glass. Installation procedure is similar to "Windshield Replacement" found earlier in this section with exception of steps relating to urethane adhesive.

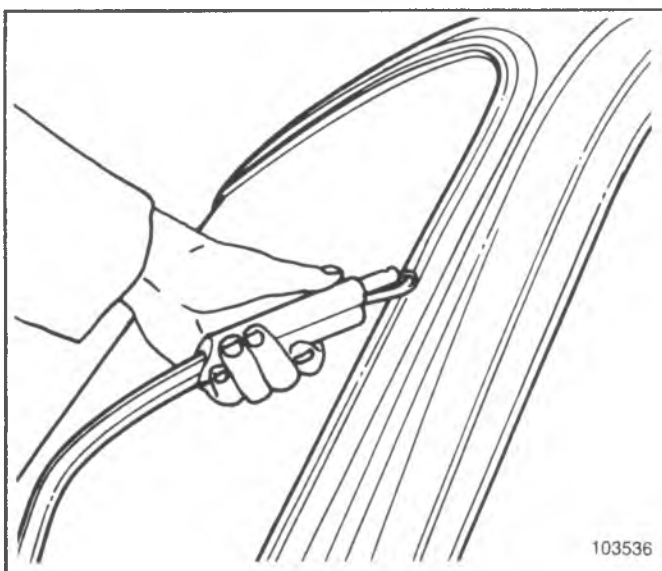

Fig. 2D-19--Installing Reveal Molding

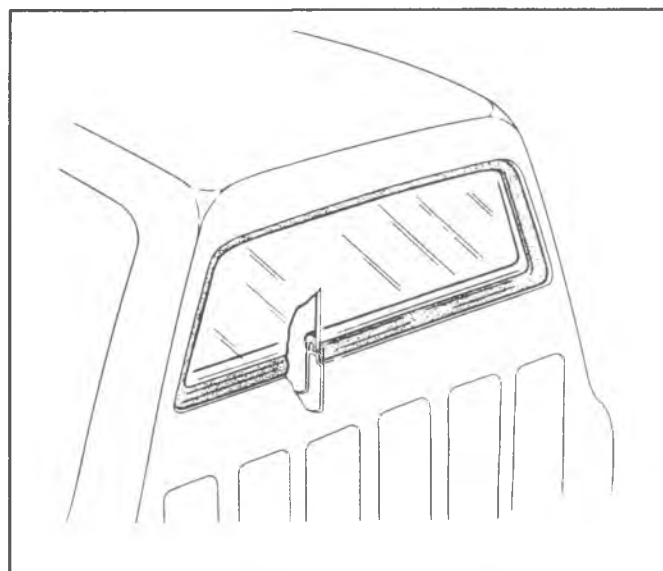

Fig. 2D-20--Back Window Glass

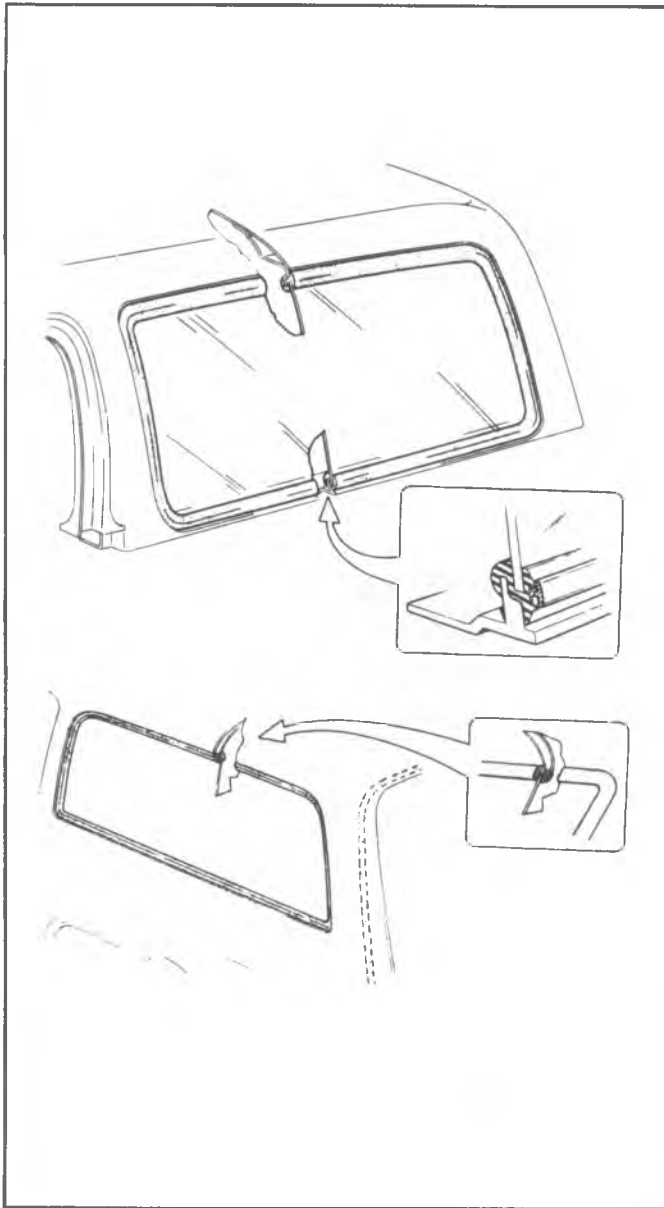

Fig. 2D-21--Body Side Window

## BODY SIDE DOORS

### DOOR ADJUSTMENTS

Doors can be adjusted for alignment of clearance in the cab door opening, and for proper latching. Door alignment adjustments are made at the striker bolt, and at door hinges. The door, when properly located in door opening, will have .19 inch clearance at the top and side edges, and .25 inch clearance at the bottom. The door should be adjusted in the opening so the edge of the door across the top and also at the lock side is parallel with the body opening as nearly as possible.

### Hinge Adjustment

Door hinge bolt holes are oversized to make adjustment possible. Alignment adjustments can be made by loosening the proper hinge bolts, aligning door to proper position, and tightening bolts securely (fig. 2D-22).

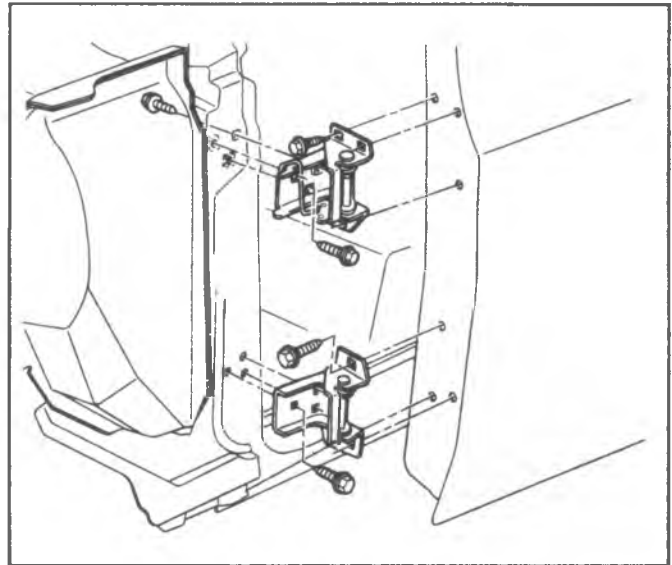

Fig. 2D-22--Door Hinge

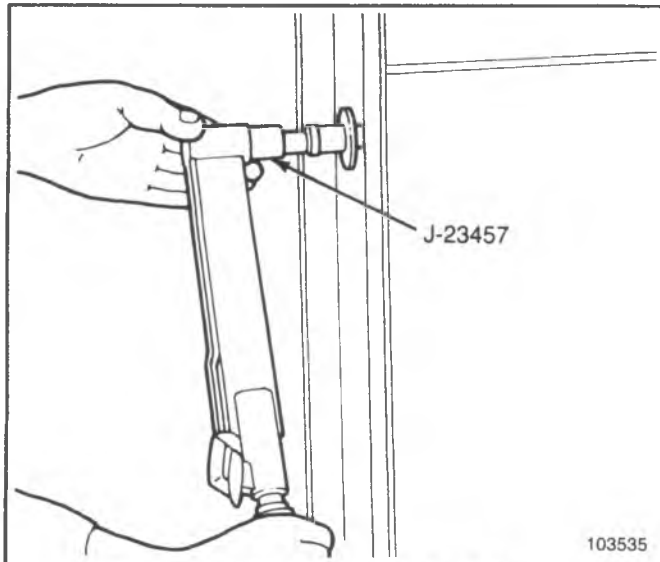

Fig. 2D-23--Loosening Striker Bolt

### Striker Bolt Adjustment

With the use of J-23457, shown in figure 2D-23, the striker bolt can be adjusted in any of three ways. See figure 2D-24.

1. **Up and down** - To adjust striker up or down, loosen bolt, adjust to desired height, and tighten bolt securely. This adjustment is important to assure that the right proportion of door's weight will rest on striker bolt when door is closed. If bolt is positioned too high on pillar, rapid wear will occur to the lock cam; if too low, an extra load will be placed on door hinges as well as pull door downward and out of alignment.
2. **In and Out** - To adjust striker in and out, loosen bolt, adjust horizontally to desired position and tighten bolt securely.
3. **Forward and Rearward**--To make this adjustment, loosen striker bolt, shim to desired position, and tighten bolt securely.

### FRONT SIDE DOOR

#### Replacement

Remove the door assembly from the body by removing the hinge-to-door attaching bolts.

#### DOOR HINGE

The door check is part of the front door upper hinge. The front door torque rod check holds the door in either of two positions between full open and closed. The front door check-hinge assembly is replaced as a complete unit as follows. See figure 2D-22.

#### Removal

1. Loosen front fender rear bolts.
2. With special Tool J-22585 remove 3 bolts securing front door upper hinge to cowl pillar.
  - a. Remove the door to upper hinge retaining bolts.

- b. With aid of an assistant to support weight of door, remove the door to lower hinge retaining bolts and remove door.

#### Installation

1. Install hinge snugly on pillar in same location as hinge removed.
2. With the aid of an assistant fasten the door to the hinge.
3. Adjustment of the door lock and striker plate should be made after the door is positioned in the opening.

### DOOR TRIM PANELS - CK MODELS

#### Removal

1. Using tool J-9886-01, remove clip retaining window crank (fig. 2D-26).
2. Remove door lock knob.
3. Remove (4) screws securing lower edge of trim panel.
4. Remove (2) arm rest attaching screws and remove arm rest pad.
5. Remove (1) screw at door handle cover plate and (1) screw located under arm rest pad.
6. If equipped assist strap, remove (2) screws retaining assist strap.
7. Remove trim panel by carefully prying out at trim retainers located around perimeter of panel.

#### Installation

Before installing door trim assembly, check that all trim retainers are securely installed to the assembly and are not damaged.

1. To install door trim assembly, pull door inside handle inward; then position trim assembly to inner panel, inserting door handle through handle hole in panel.
2. Position trim assembly to door inner panel so trim retainers are aligned with attaching holes in panel and tap retainers into holes with a clean rubber mallet.
3. Install previously removed items.

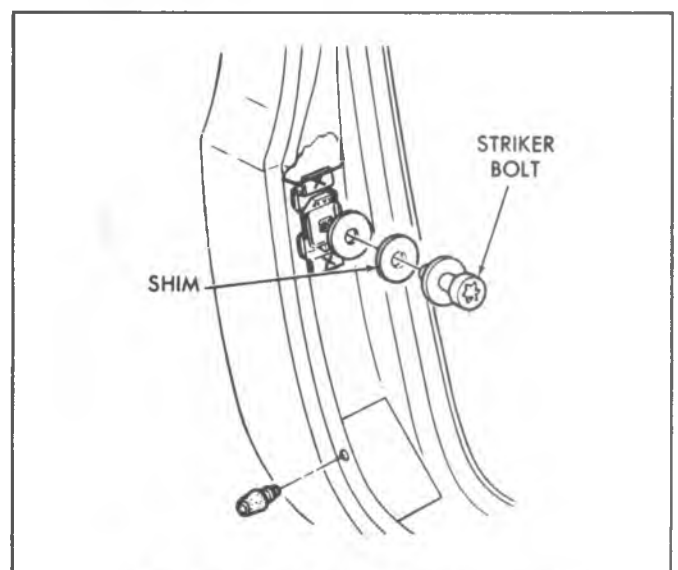

Fig. 2D-24--Typical Striker Bolt Adjustment

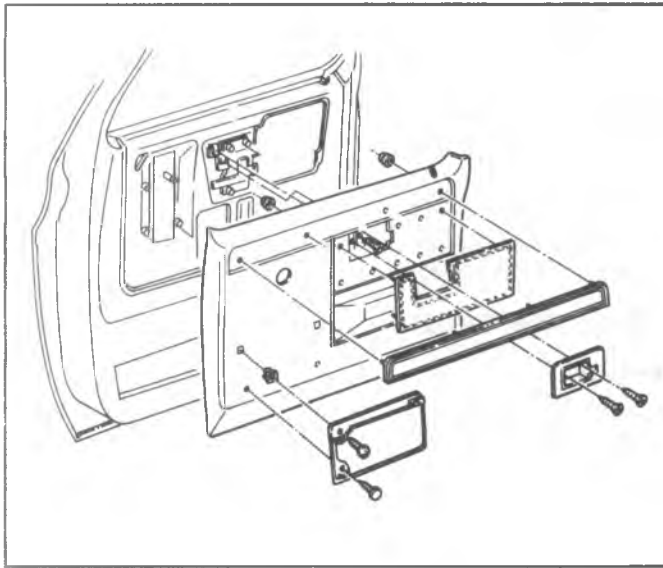

Fig. 2D-25--Door Trim Panel

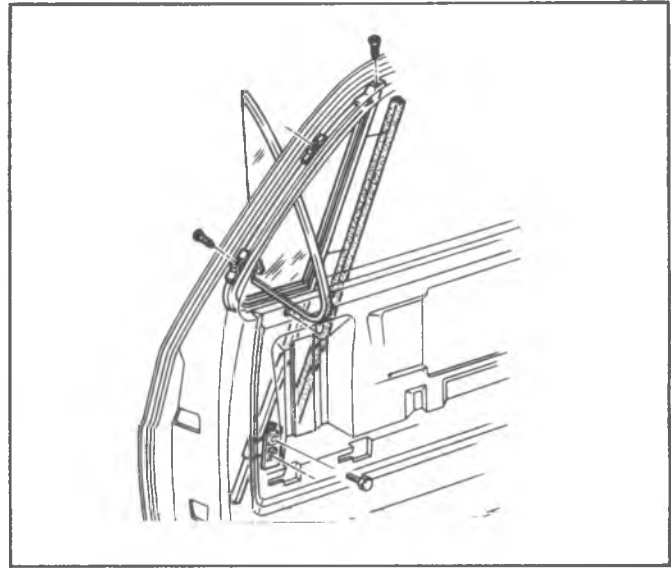

Fig. 2D-28--Door Ventilator Assembly

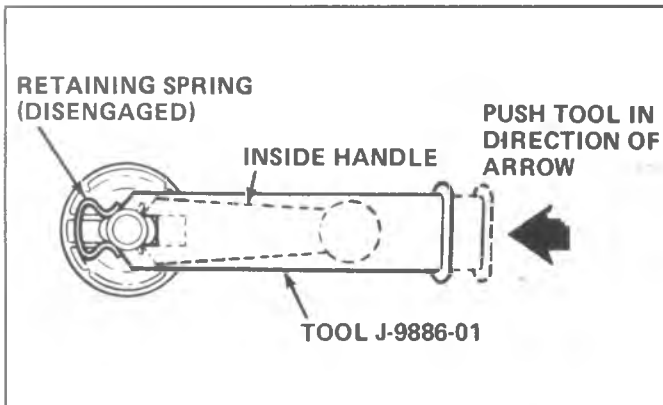

Fig. 2D-26--Clip Retained Inside Handle Removal

**DOOR VENTILATOR ASSEMBLY--Fig. 2D-28**

**Removal**

The channel between the door window glass and door vent is removed as part of the vent assembly.

1. Regulate the door window glass to the full down position.
2. Remove clip from the window regulator handle, and knob from lock rod.
3. Remove arm rest screws and trim panel. See figure 2D-27.
4. Remove screws attaching ventilator lower assembly to door panel.
5. Remove three screws at the upper front of the door frame.
6. Pull upper portion of vent assembly rearward and raise upward while rotating counter clockwise.
7. Turn vent assembly 90° and carefully remove by guiding up and out. See figure 2D-29.

**Ventilator Glass Replacement**

1. Using an oil can or similar means, squirt prepsol or equivalent on the glass filler all around the glass channel or frame to soften the old seal. When

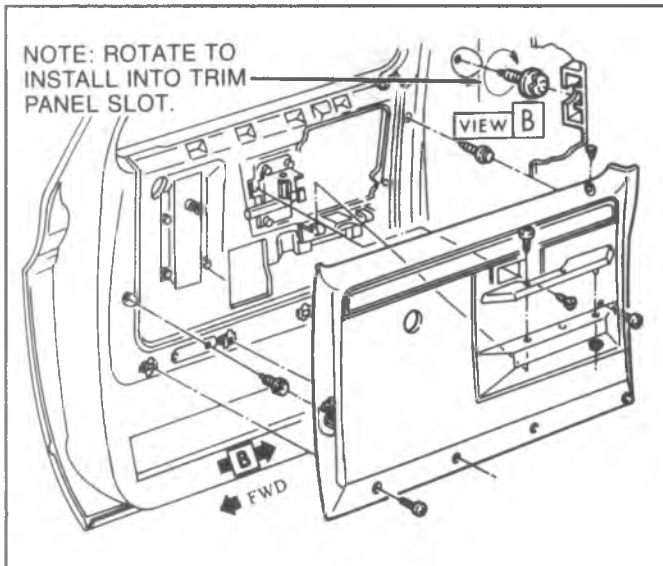

Fig. 2D-27--Door Trim Pad



Fig. 2D-29--Removing Ventilator Assembly

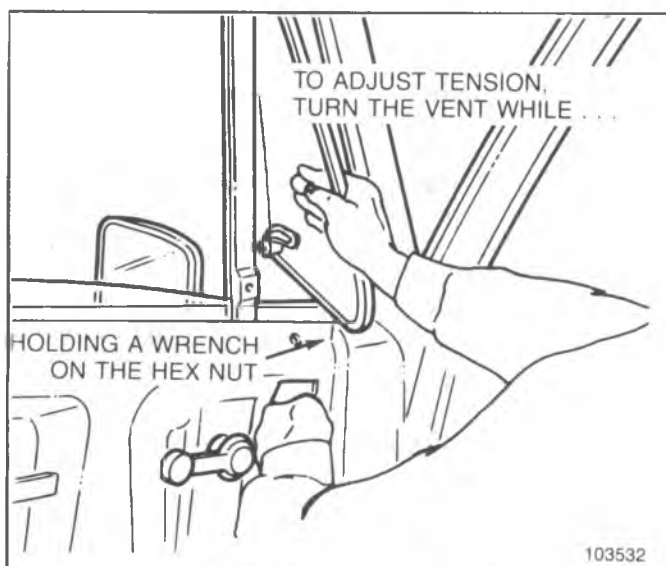

Fig. 2D-30--Adjusting Tension

the seal has softened, remove the glass from the channel.

2. Thoroughly clean the inside of the glass channel with sandpaper, removing all rust, etc.
3. Using new glass channel filler, cut the piece to be installed two inches longer than necessary for the channel. Place this piece of filler (soapstoned side of filler away from glass) evenly over the edge of the glass which will fit in the channel. The extra filler extending beyond the rear edge of the glass should be pinched together to hold it in place during glass installation.

One side of this filler (the outside of the roll) is soapstoned. This is the side which goes into the metal channel.

4. Brush the inside of the metal glass channel freely with ordinary engine oil. This will enable the glass and filler to slide freely into the channel. Push the glass with the filler around it into the channel until it is firmly seated. After the glass is firmly in place, the oil softens the filler, causing it to swell, thereby making a watertight

seal. Trim off the excess filler material around the channel and at the ends of the channel.

Glass should be installed so that rear edge is parallel to the division post. Allow full cure before water testing.

**Installation**

1. Lower the ventilator assembly into the door frame.
2. Make certain the rubber lip is positioned inside the inner and outer panel before tightening screws.
3. Reinstall all screws and tighten.
4. Install and tighten the three screws at the upper front of the door.

**Adjustment**

1. Adjust the ventilator by placing wrench on adjusting nut thru access hole and **turning vent window** to the desired tension. See figure 2D-30.
2. After making adjustment bend tabs over the hex nut on base of assembly. See figure 2D-31.
3. Install arm rest screws and trim panel.
4. Install window regulator handle.

**DOOR WINDOW ASSEMBLY--FIG. 2D-32**

**Replacement**

1. Completely lower glass to bottom of door.
2. Remove door arm rest and trim pad as outlined in this section.
3. Mask or cover upper portion of door window frame. Remove ventilator assembly as previously outlined.
4. Slide glass forward until front roller is in line with notch in sash channel. Disengage roller from channel.
5. Push window forward and tilt front portion of window up until rear roller is disengaged. See figure 2D-33.
6. Put window assembly in normal position (level) and raise straight up and out.
7. Reverse above procedure for installation.

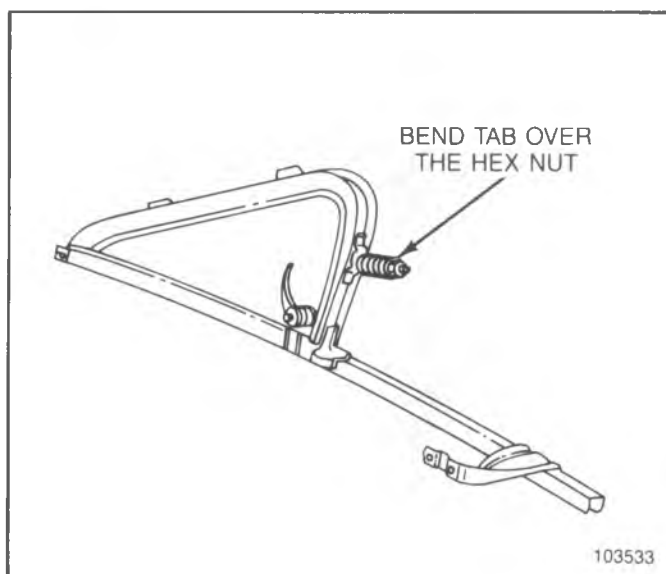

Fig. 2D-31--Bend Tabs Over Hex Nut

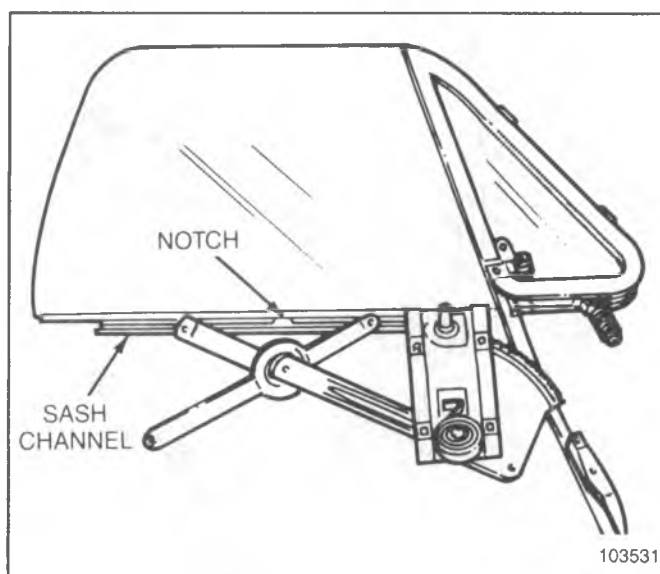

Fig. 2D-32--Door Window and Regulator



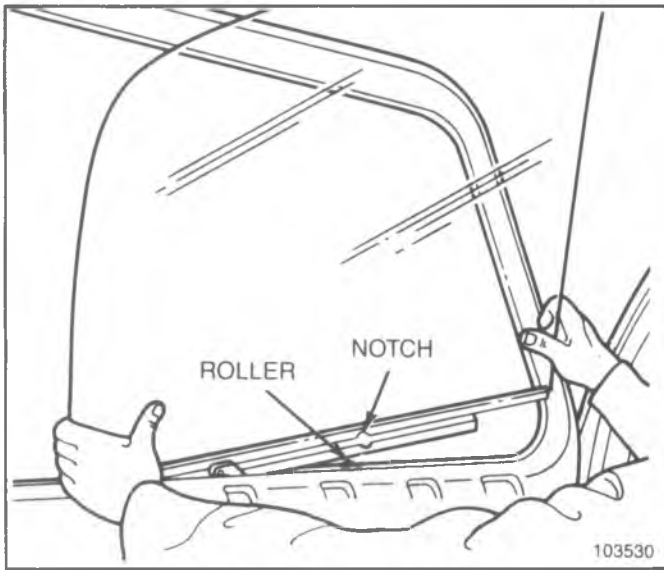

Fig. 2D-33--Removing Door Glass

**WINDOW REGULATOR-MANUAL--FIG. 2D-32**

**Replacement**

1. Raise window and tape glass in full up position using cloth body tape.
2. Remove trim panel as outlined previously.
3. Remove screws attaching regulator to door inner panel.
4. Remove regulator by sliding regulator rearward, disengaging rollers from sash channel.

A notch is provided in the sash channel to allow disengagement of the forward roller on the window regulator (Fig. 2D-32).

5. Install regulator by reversing above steps. Lubricate regulator gear with lubriplate or equivalent.

**WINDOW REGULATOR - POWER - CK MODELS**

In the case that window will not operate, check electrical connections first. Figure 2D-34 illustrates

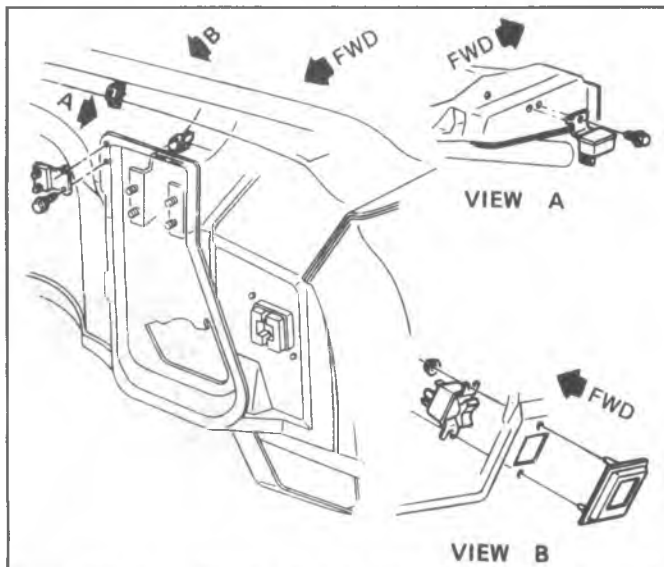

Fig. 2D-34--Power Window Switch, Relay and Breaker Assembly

location of junctions, switch, relay and circuit breaker.

**Replacement**

**CAUTION: Electrical connectors must be removed from window lift motor before performing any operation on the regulator, or personal injury could occur. Figure 2D-35 illustrates location of regulator on door and wiring.**

1. Raise glass to full up position and tape to door frame using cloth body tape.
2. Disconnect battery ground cable.
3. Remove door trim panel as previously outlined.
4. Remove remote control bolts and lay control assembly aside for access.
5. Remove regulator to door panel attaching screws.
6. Disconnect harness from regulator.
7. Slide regulator assembly rearward, disengaging rollers from sash channel.

A notch is provided in the sash channel to allow disengagement of the forward roller on the window regulator (fig. 2D-32).

8. Remove regulator assembly through access hole in door.

**CAUTION: Step 9 must be performed when regulator is removed from door. The regulator lift arms are under tension from the counterbalance spring and can cause serious injury if the motor is removed without locking the sector gear in position.**

9. Drill a hole through the regulator sector gear and back plate. DO NOT drill hole closer than 1/2" (12.7mm) to edge of sector gear or back plate. Install a pan head sheet metal tapping screw (No. 10 - 12 x 3/4) in drilled hole to lock sector gear in position.
10. Remove motor to regulator attaching screws.
11. Remove motor from regulator.

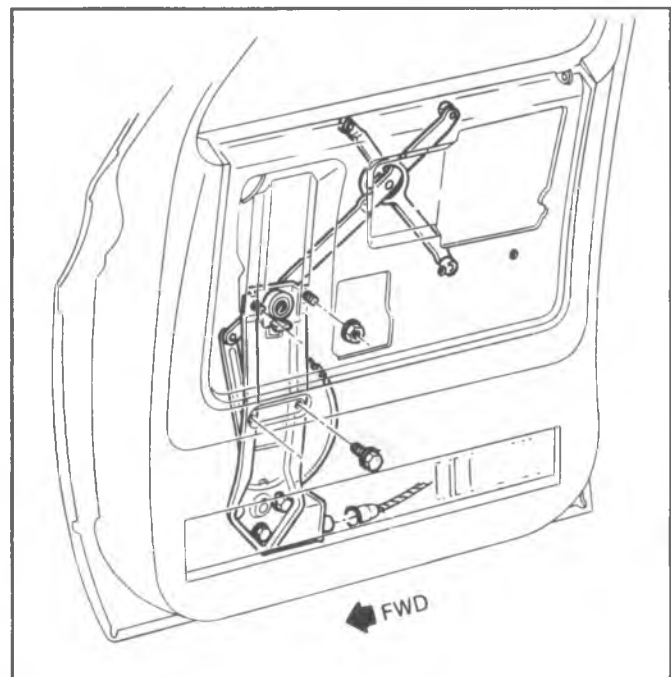

Fig. 2D-35--Power Window Regulator, Motor and Connector



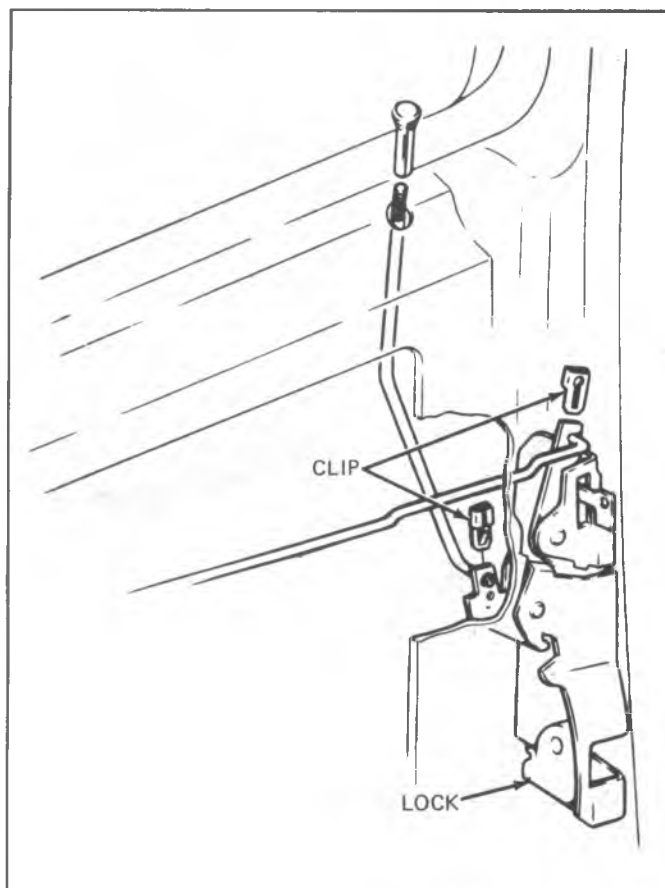

Fig. 2D-36--Door Lock Assembly and Rods

12. Prior to installation, lubricate the motor drive gear and regulator sector teeth. The lubrication used must be cold weather approved to a minimum of minus 20° Fahrenheit (-29°C).
13. Install regulator motor to regulator. Make sure the motor pinion gear teeth mesh properly with the sector gear teeth before installing the three motor attaching screws.
14. Remove screw locking sector gear in a fixed position.
15. Insert regulator into door in such a position that motor connector can be installed onto motor.
16. Reinstall regulator into door.

## LOCKS, HANDLES AND RODS

### Door Lock Assembly--Fig. 2D-36

#### Replacement

1. Raise window to full up position.
2. Remove trim panel as outlined in this section.
3. Remove clip from inside handle rod-to-lock.
4. Remove clip from outside handle rod-to-lock.
5. Remove screws which attach lock assembly to door panel.
6. Remove lock and remote control rod as an assembly.
7. To install lock assembly, reverse above steps. Be sure to replace all clips removed earlier.

### Door Outside Handle--Fig. 2D-37

#### Replacement

1. Raise window to full up position.
2. Remove trim panel as outlined.
3. Remove clip from outside handle rod-to-lock.
4. Remove screws which retain outside handle to door panel.
5. Remove handle and control rod.
6. Reverse above procedures to install outside handle.

### Door Lock Cylinder -Fig 2D-37

#### Replacement

1. Raise door window.
2. Remove trim panel as outlined.
3. Use a screwdriver or other suitable tool to slide the lock cylinder retaining clip out of engagement with the lock cylinder.
4. Remove lock cylinder.
5. To install, reverse the above steps.

### Door Inside Handle

#### Replacement

1. Remove trim panel as outlined.
2. Disconnect control rod from inside handle, as shown in figure 2D-38.
3. Remove screws retaining inside handle to door.
4. Remove inside handle.
5. Reverse above steps to install.

## POWER DOOR LOCKS - CK MODELS (Fig. 2D-39)

#### Replacement

1. Disconnect battery ground cable.
2. Remove door trim panel to gain access to power door lock motor.
3. Disconnect electrical connector from motor.
4. Remove screws attaching motor to door inner panel.

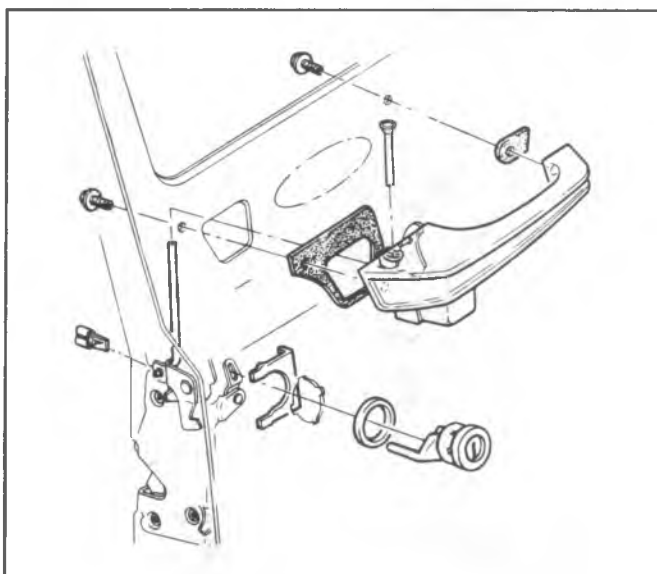

Fig. 2D-37--Outside Handle and Lock Cylinder

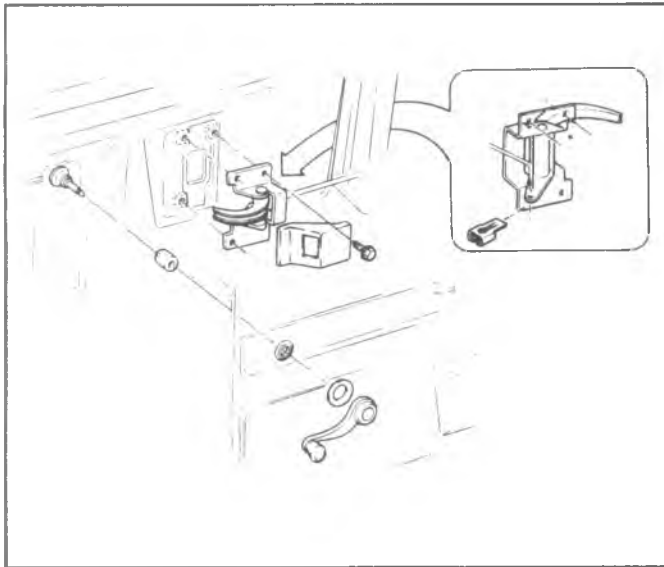

Fig. 2D-38--Inside Handle

5. Remove door lock lever from rubber mount at top of motor actuator and remove motor through access hole.
6. To install, reverse steps 1 through 5 above.

### DOOR TO BODY OPENING WEATHERSTRIP--FIG. 2D-40, 2D-41

Side door sealing incorporates an inner seal Fig. 2D-40 and a secondary seal Fig. 2D-41. The inner seal is mounted on the body opening welding flange and goes completely around the periphery of the opening. The secondary seal is adhered to the upper portion of the door by adhesive and a screw at either end of the seal. The molded weatherstrip material of the inner seal is snapped in place. After removing all foreign material from door opening surface proceed as follows:

1. Open door and block open.
2. Remove sill plate retaining screws and remove sill plate.
3. Remove side door inner weatherstrip seal.
4. Starting at the bottom center of the door opening,

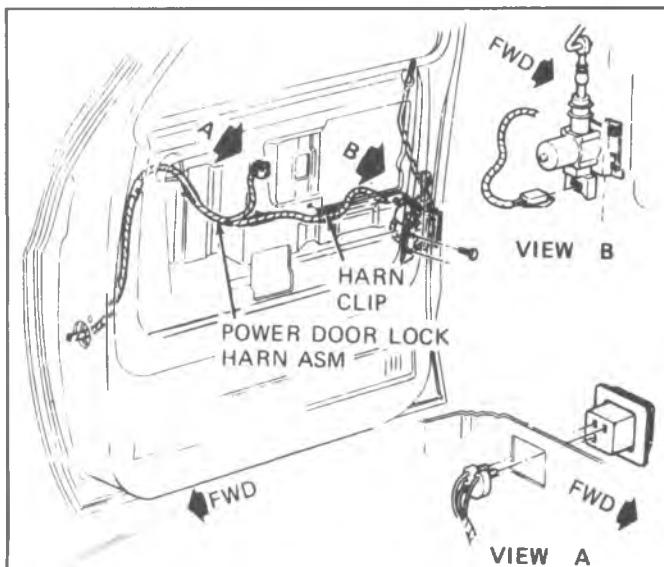

Fig. 2D-39--Power Door Lock Assembly

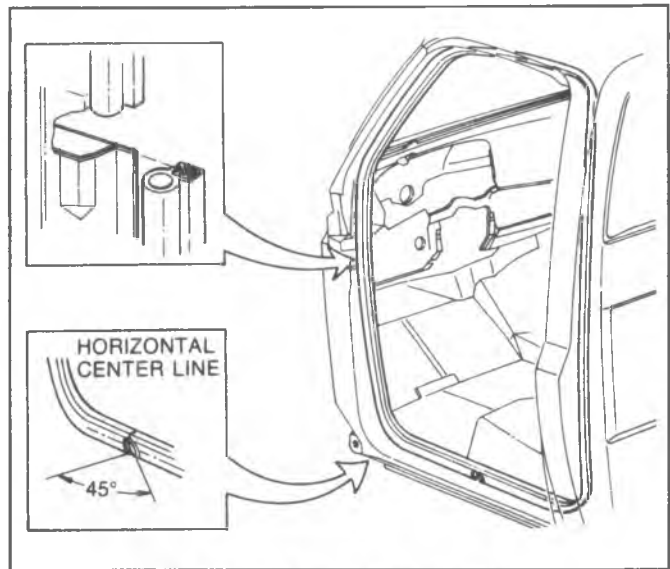

Fig. 2D-40--Door Weatherstrip CK

- install seal on welded flange.
5. Trim inner weatherstrip with a notch and butt ends together.
6. Reinstall sill plate and sill plate retaining screws.

### REAR SIDE DOOR-CREW CAB AND SUBURBAN MODELS

#### Adjustments and Hinge Replacement

The procedures for hinge replacement, and for hinge and striker bolt adjustment are similar to those detailed in the front door adjustment procedure. Access to the hinges of the rear door is shown in figure 2D-42.

### STATIONARY GLASS--REAR DOOR

#### Replacement

1. Lower window to full down position.
2. Remove remote control knob and window regulator handle.

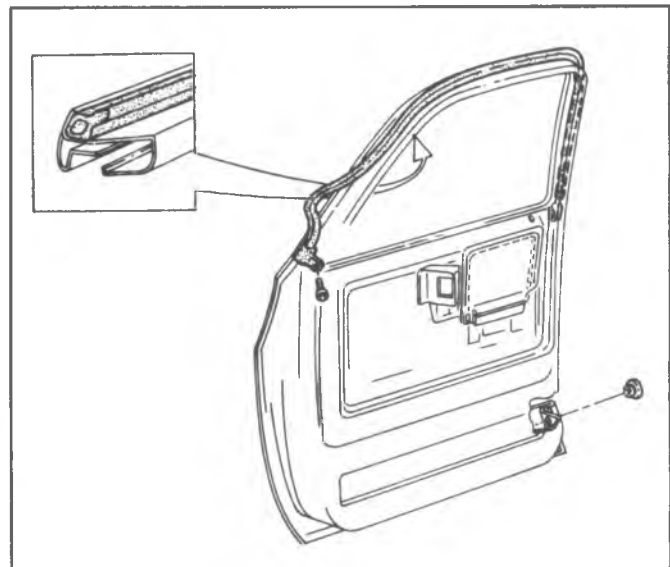

Fig. 2D-41--Door Secondary Seal

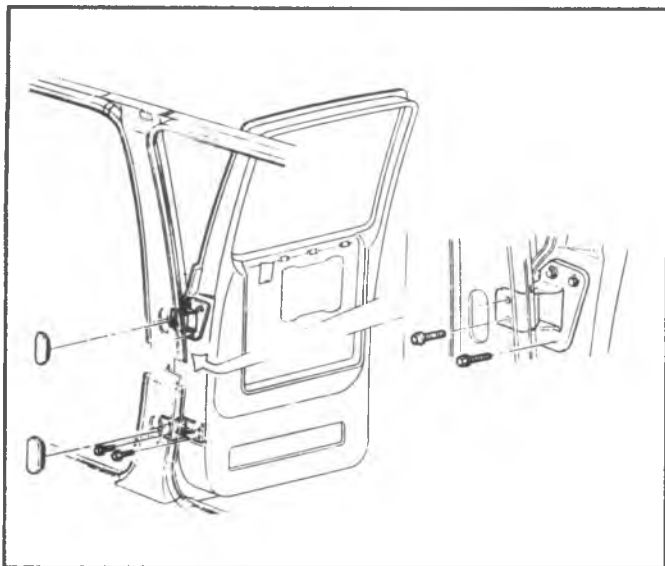

Fig. 2D-42--Rear Door Hinge Location

3. Remove screws retaining door trim pad, and remove trim pad. See figure 2D-43.
4. Remove glass run channel by removing screws retaining channel to door. See figure 2D-44.
5. Remove stationary glass.
6. Replace glass by reversing above procedure.

**Glass Run Channel Adjustment**

Figure 2D-45 illustrates the front run channel. At the lower end, a slotted bracket provides for in-and-out

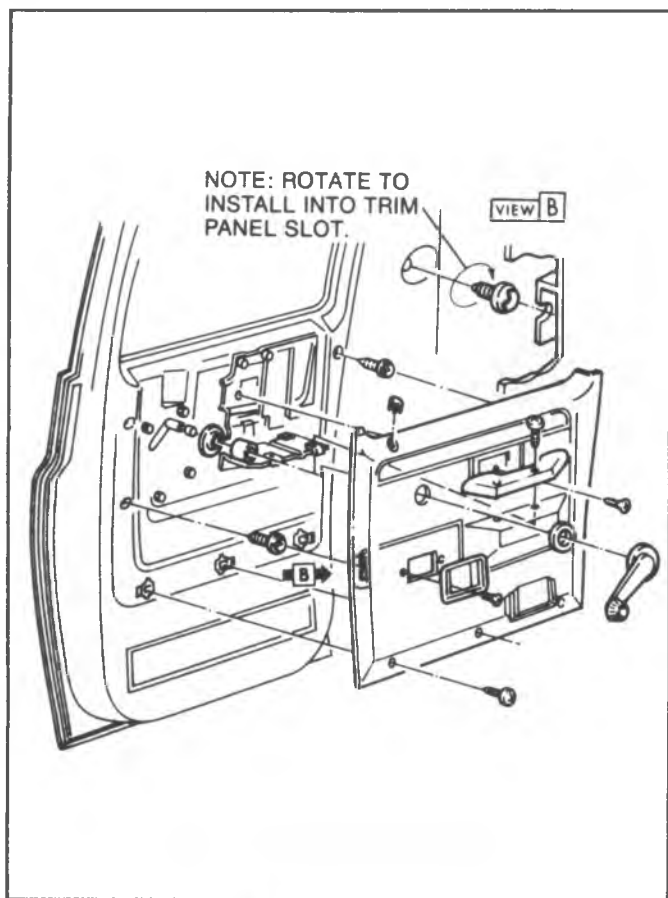

Fig. 2D-43--Side Rear Door Trim Pad

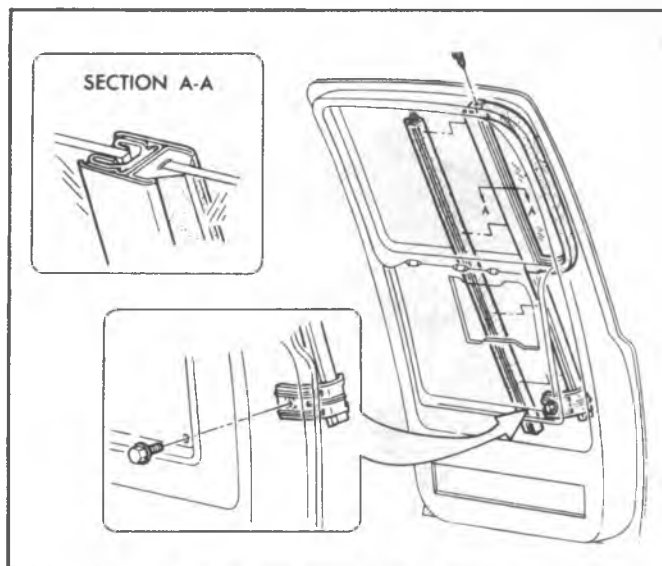

Fig. 2D-44--Glass Run Channel

adjustment. The screw and locknut at that bracket allow fore-and-aft adjustment. Together, this allows proper alignment of the glass to the rear glass run channel for full up and down travel.

**WINDOW GLASS--FIG. 2D-46**

**Replacement**

1. Lower glass to full down position.
2. Remove remote control push button knob, window regulator handle and trim pad.
3. Remove stationary glass as previously outlined. Remove screws from rear division channel, and slide channel rearward in the opening.
4. Raise glass as far as possible, then slide glass until the roller is in line with the notch in the sash channel. See figure 2D-46. Disengage roller from channel.



Fig. 2D-45--Glass Run Channel Adjustment

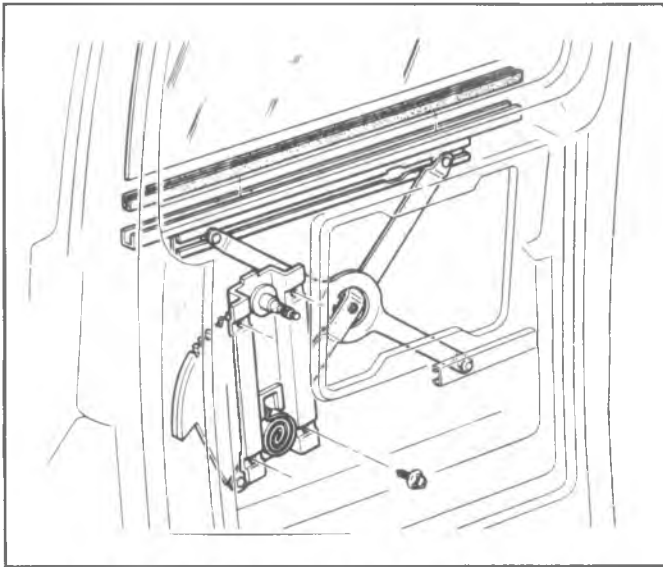

Fig. 2D-46--Window Glass and Regulator Assembly

5. Tilt window outboard and move until other roller can be removed from channel.
6. Raise window up and out.
7. Reverse above procedure for installation.

## WINDOW REGULATOR ASSEMBLY--FIG. 2D-46

### Replacement

1. Remove trim pad, stationary glass, and window glass as outlined earlier.
2. Remove screws attaching regulator assembly to door inner panel.
3. Remove regulator assembly through opening in door.
4. Install regulator by reversing above procedure. Lubricate regulator gear with lubriplate or equivalent.

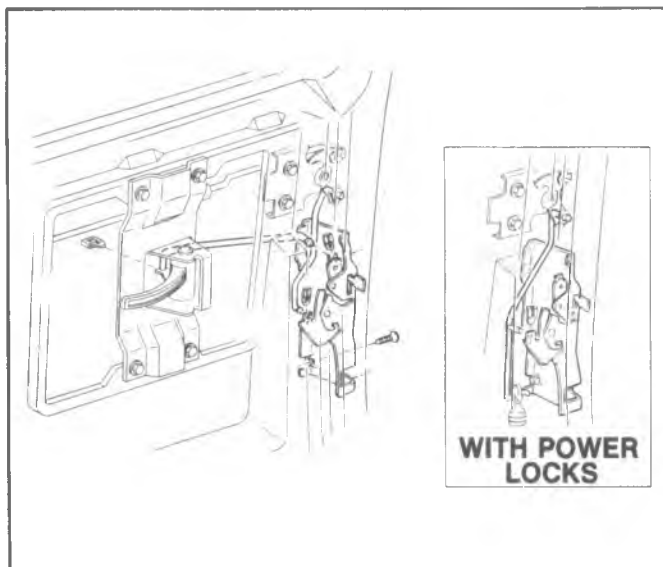

Fig. 2D-47--Lock Assembly and Inside Handle

## LOCKS HANDLES AND RODS

### Lock Assembly--Fig. 2D-47

#### Replacement

1. Remove window regulator handle, remote control push button knob and trim pad as outlined previously.
2. Disengage three clips which retain control rods to lock assembly.
  - a. Inside handle control rod.
  - b. Remote control lower rod.
  - c. Outside handle control rod.
3. Remove screws retaining lock assembly to door panel, then remove lock assembly.
4. Install lock by reversing above procedure. Be sure to replace all clips removed with new clips on installation.

### Inside Handle--Fig. 2D-47

#### Replacement

1. Remove regulator handle, remote control knob and trim pad as outlined previously.
2. Disconnect control rod from inside handle by removing clip as shown in figure 2D-47.
3. Remove inside handle by removing four screws which secure handle to door panel.
4. Replace handle by reversing above procedure.

### Remote Control--Fig. 2D-48

#### Replacement

1. Remove regulator handle, remote control knob and trim pad.
2. Disconnect remote control lower rod from door lock assembly.
3. Remove two screws securing each remote control lever to door panel.
4. Remove remote control levers and rods through door opening.
5. Replace by reversing above procedure.

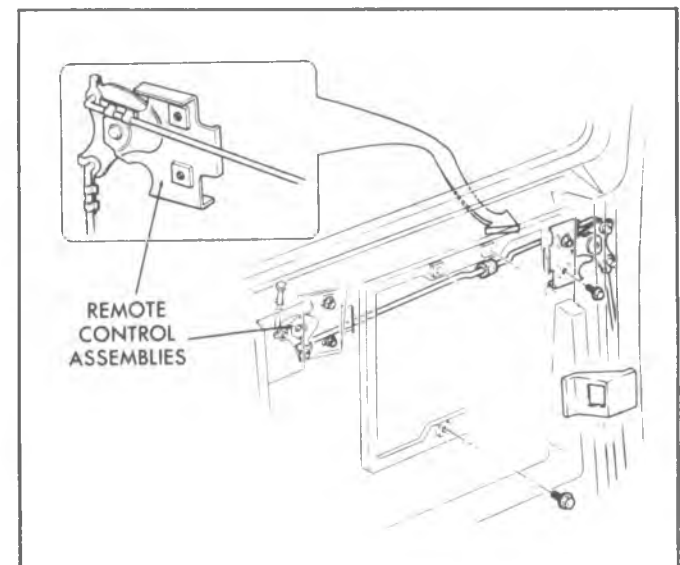

Fig. 2D-48--Remote Control Assembly

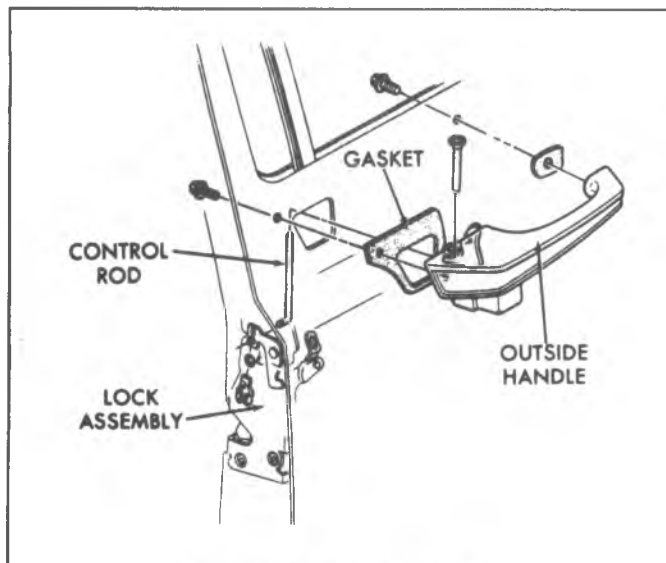

Fig. 2D-49--Outside Handle

### Outside Handle--Fig. 2D-49

#### Replacement

1. Remove the trim pad as outlined previously.
2. Remove two screws securing the handle to the door. Press the handle button and pull the handle control rod and securing clip thru the opening in the door panel. See Fig. 2D-49.
3. Disengage the outside handle control rod from the handle by removing the pin at the handle assembly.
4. Replace by reversing this procedure.

### WEATHERSTRIP--FIG. 2D-50

The procedure outlined in Front Door Weatherstrip may be applied to the Rear Side Door Weatherstrip, shown in figure 2D-50 with the following exception:

- a. Begin installation by positioning the weatherstrip "internal core" (approximately 6" long) center in the upper front corner of the door opening.
- b. Proceed as outlined previously.

### REAR DOORS SUBURBAN MODEL ONLY

#### Adjustments

Rear doors may be adjusted in the body opening by loosening hinge bolts and repositioning door, then

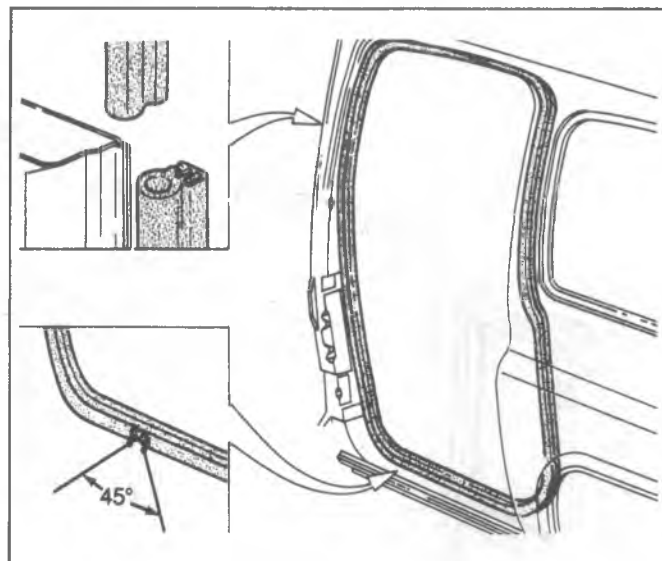

Fig. 2D-50--Side Rear Door Weatherstrip

retightening bolts. See figure 2D-54 for hinge bolt location. Rear door wedges and strikers should be adjusted as shown in figure 2D-55.

Be sure that adjustments are as shown to insure proper latching of the rear doors.

### LOCKS, HANDLES AND RODS

The rear door lock, outside handle, lock cylinder, control rods and latch are shown in figures 2D-51 and 2D-52. The rods can be disconnected from the lock, latch or handle by disengaging the retaining clips, as shown. The lock cylinder is removed in the same manner as the front side door lock cylinder.

### REAR DOOR CHECK STRAP

Figure 2D-53 shows the cloth check strap used for rear doors. The door may be completely opened by removing the strap pin from the bracket. The bracket attaches to the pillar with three screws; the strap is fastened to the door panel with two screws and an attaching bar.

### WEATHERSTRIP

Weatherstrip installation is shown in Figs. 2D-55 and 2D-56. Proper installation is dependent on completely cleaning all foreign material from old installation and using a quality cement on the new installation.

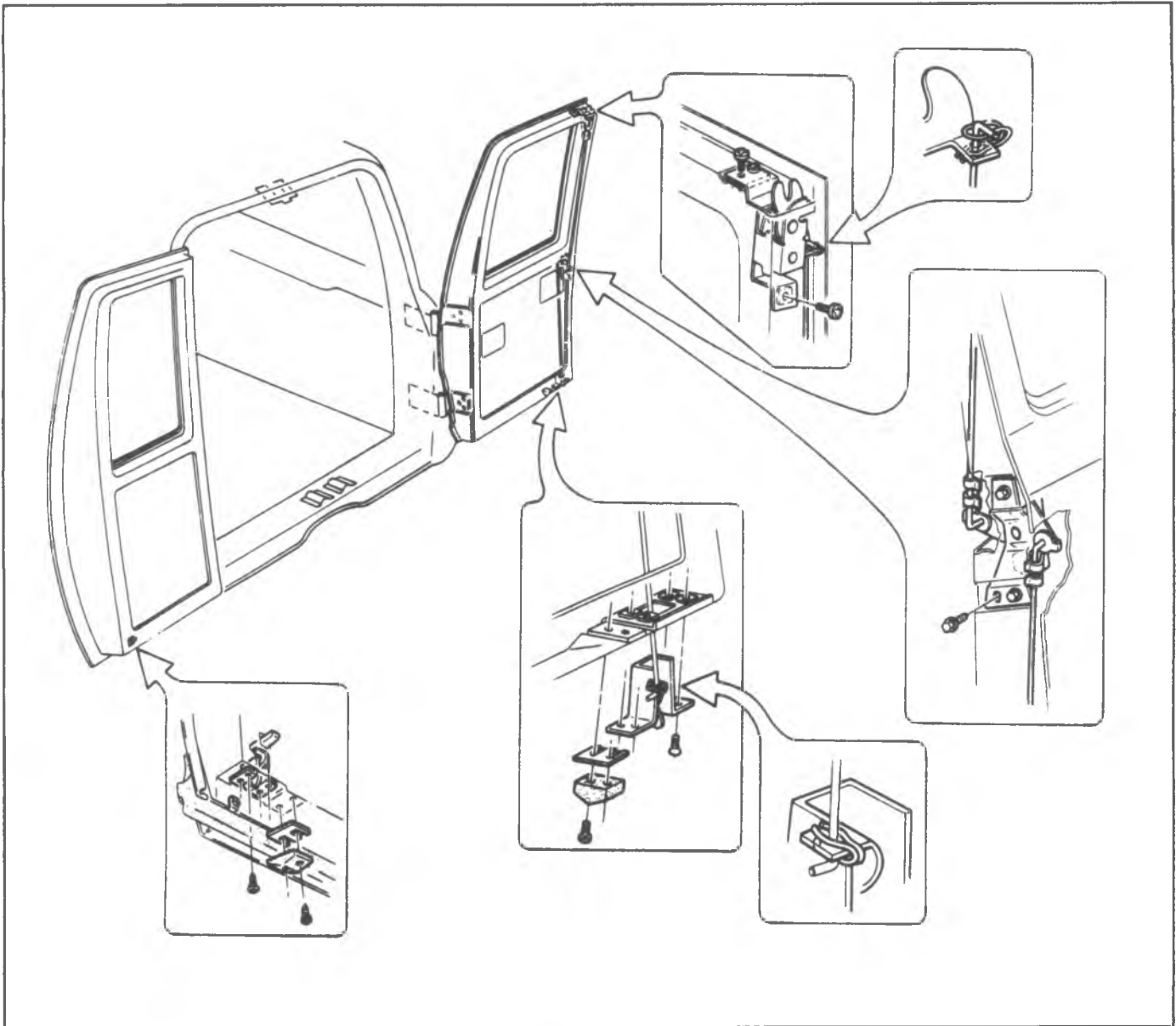

Fig. 2D-51--Rear Door Controls

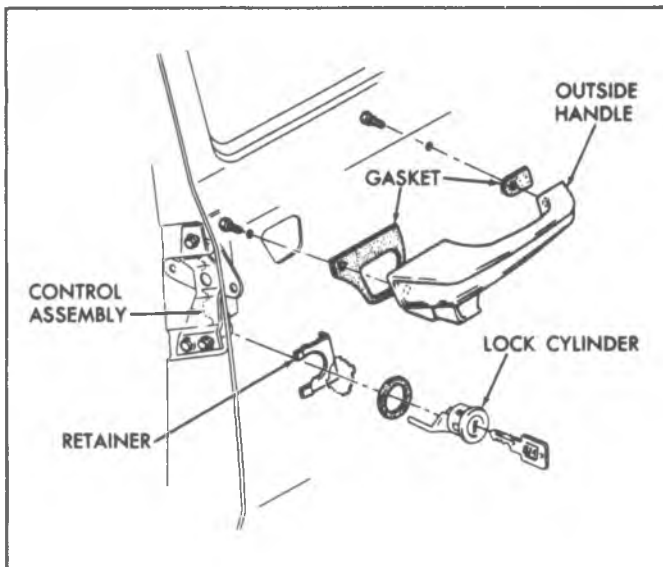

Fig. 2D-52--Rear Door Outside Handle and Lock Cylinder

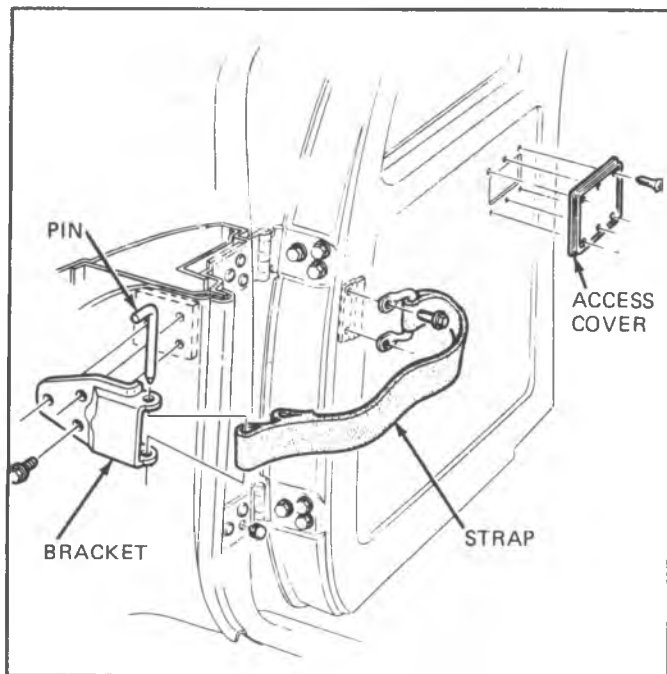

Fig. 2D-53--Rear Door Check Strap

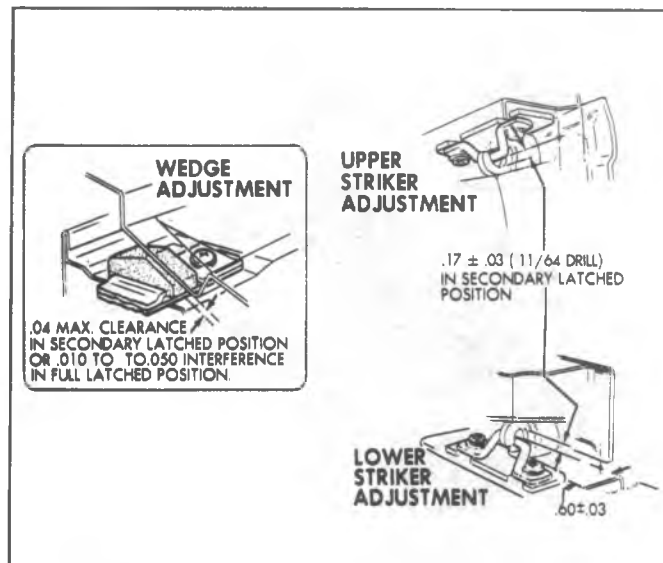

Fig. 2D-54--Wedge and Striker Adjustments

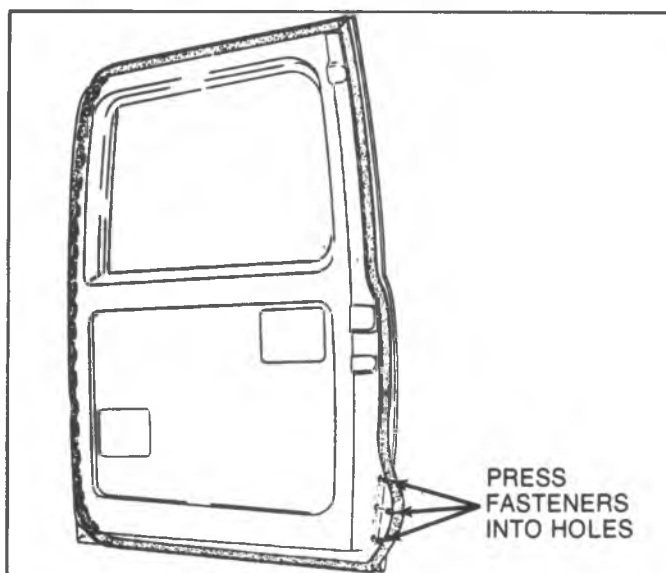

Fig. 2D-56--Weatherstrip--R.H. Rear Door

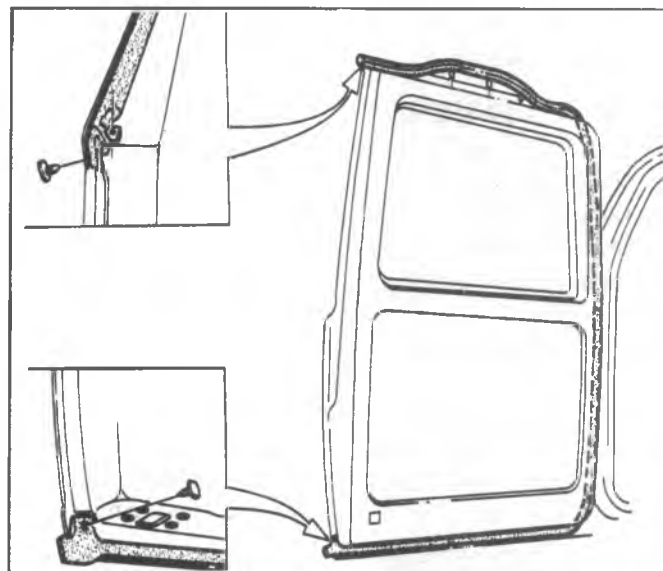

Fig. 2D-55--Weatherstrip - L.H. Rear Door

## ENDGATES SUBURBAN AND UTILITY MODELS

Suburban and utility models use endgates of similar, yet distinct design. Separate procedures follow for service on each of these endgates.

### ENDGATE ASSEMBLY - SUBURBAN MODELS ONLY

#### Replacement

1. Lower endgate, and removed hinge access covers. See figure 2D-57.
2. Remove endgate-to-hinge bolts.
3. Remove L.H. torque rod bracket, shown in figure 2D-58.
4. If equipped with electric powered window, disconnect wiring harness.

5. Lift endgate to almost closed position and remove support cables.
6. Remove endgate with torque rod.
7. To install, reverse removal procedure.

### HINGES

#### Replacement

If necessary to remove hinges, remove endgate as outlined previously, and proceed as follows:

1. Remove bolts from each of the hinge assemblies on the underside of the body. See figure 2D-57.
2. Remove hinge assemblies. If the hinge pins are to



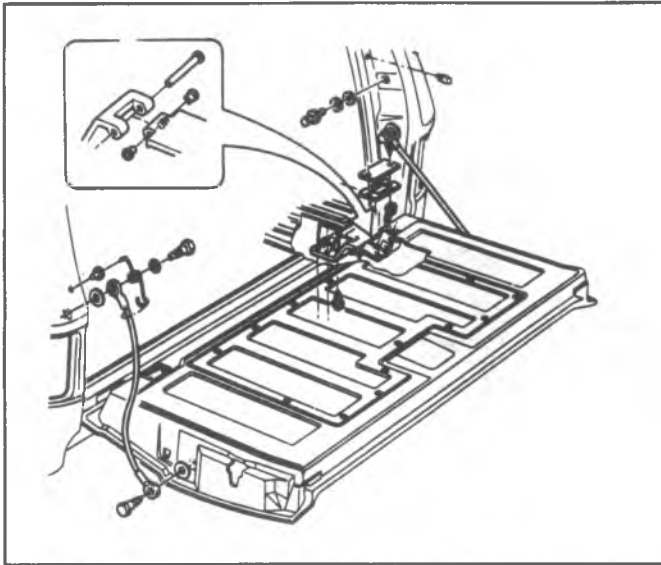

Fig. 2D-57--Endgate, Hinges and Supports--(Suburban)

be removed, note the position of bushings so they may be reinstalled in the same position.

- Reverse procedure to install.

### ENDGATE DISASSEMBLY

- Remove access cover shown in figure 2D-59, to gain access to interior components.
- Detach remote control rods from lock assembly by removing clips.
- Remove bolts securing lock assembly, and remove lock assembly.
- Remove handle assembly bolts and remove inside handle.
- Remove R.H. torque rod bracket screws, figure 2D-58, then remove torque rod from endgate.
- Remove screws connecting cam assemblies to sash assembly, figure 2D-60, then remove cam assemblies.
- Remove glass from endgate.
- Unclip and remove inner and outer seal assemblies.
- Remove screws connecting window regulator assembly

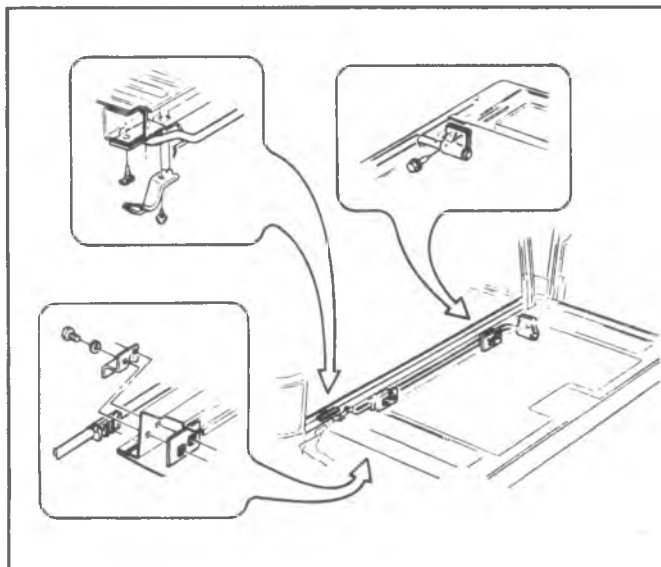

Fig. 2D-58--Torque Rod(Suburban)

to endgate, figure 2D-60, and remove regulator.

**CAUTION:** Step 10 must be performed if the window is removed or disengaged from the regulator lift arms. The lift arms are under tension from the counter-balance spring, and can cause injury if the motor is removed without locking the sector gears in position.

- For endgates with electric window, secure the window regulator lift arms before removing the electric motor, when the window glass has been removed or disengaged from the lift arms.
  - Drill a 1/8 (3.1mm) inch hole through the sector gear and back plate, as shown in figure 2D-60. Install a sheet metal tapping screw into the hole to lock the sector gears in position.
  - Remove the regulator motor attaching screws and remove the motor assembly.
- From inside the endgate, remove the nuts fastening the outside handle to endgate and remove the outside handle. See figure 2D-61.
 

If equipped with power tailgate window, detach wiring harness from motor.
- Remove side bolts connecting left and right glass channels to endgate and remove channels.
- Remove side latch bolts and remove side latches with control rods. See figure 2D-59. Detach wiring harness from R.H. latch if so equipped.
- Separate side latch from control rod by pulling control rod thru nylon guide.
- Reverse the above procedure for reassembly and installation.

### Adjustments

Loosen bolts, adjust at either endgate hinge position or endgate latch, then retighten bolts.

### ENDGATE ASSEMBLY--UTILITY MODELS ONLY

#### Replacement

- Lower endgate, then remove four bolts securing hinge to body on each side. See figure 2D-62. Disconnect wiring harness if so equipped.

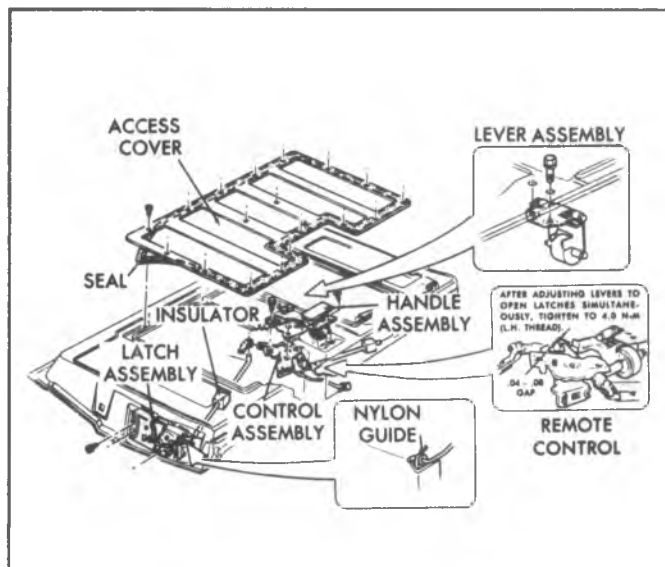

Fig. 2D-59--Latch and Remote Controls(Suburban)



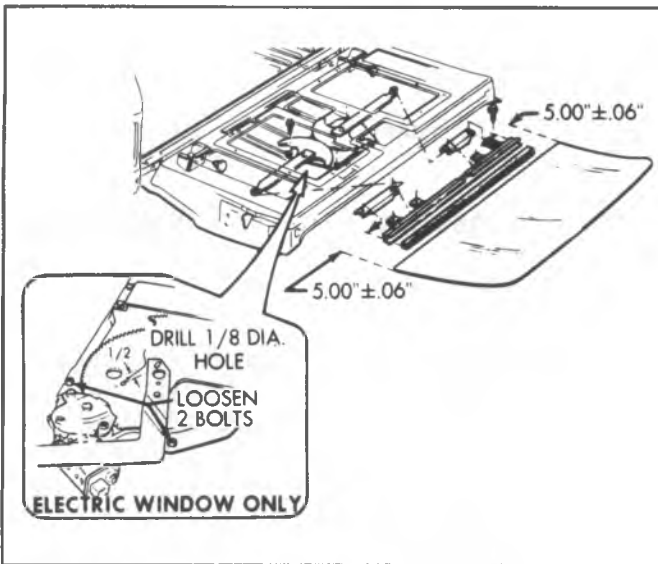

Fig. 2D-60--Window Glass and Regulator(Suburban)

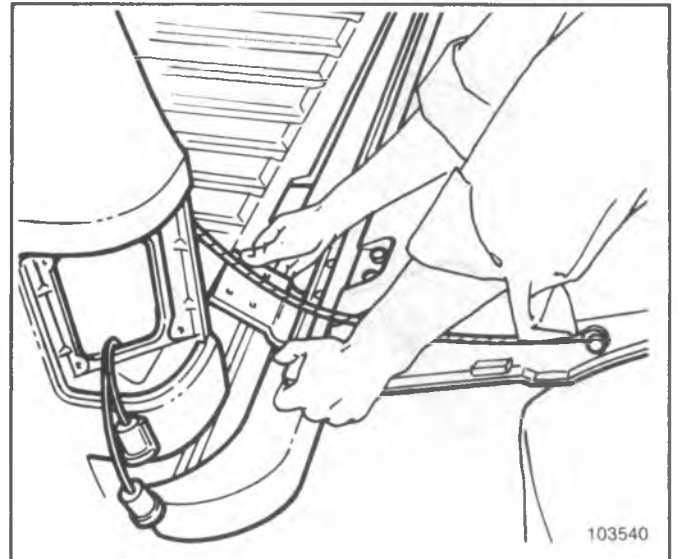

Fig. 2D-63--Pulling Hinge Away From Body (Utility)

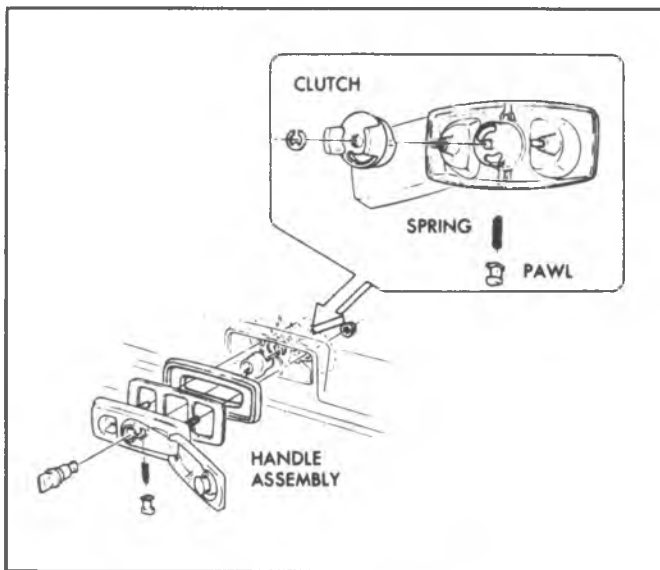

Fig. 2D-61--Outside Handle

2. Disconnect torque rod anchor plate on each side. It is necessary to remove lower bolt only, then let plate swing down. See figure 2D-66.
3. With an assistant, raise endgate part way, then disconnect support cables from endgate. See figure 2D-62.
4. Remove endgate by pulling disconnected hinge from body, figure 2D-63, then grasping torque rod with one hand and pulling torque rod over gravel deflector, as shown in figure 2D-64.
5. Individual components may be removed from the endgate now, or after reinstallation.
6. To install endgate, reverse the above procedure.

**HINGE**

**Replacement**

1. Lower endgate and disconnect hinge to be replaced by removing hinge-to-body bolts. See figure 2D-62.
2. At the other hinge, loosen the hinge-to-body bolts.
3. On the hinge to be replaced, remove the

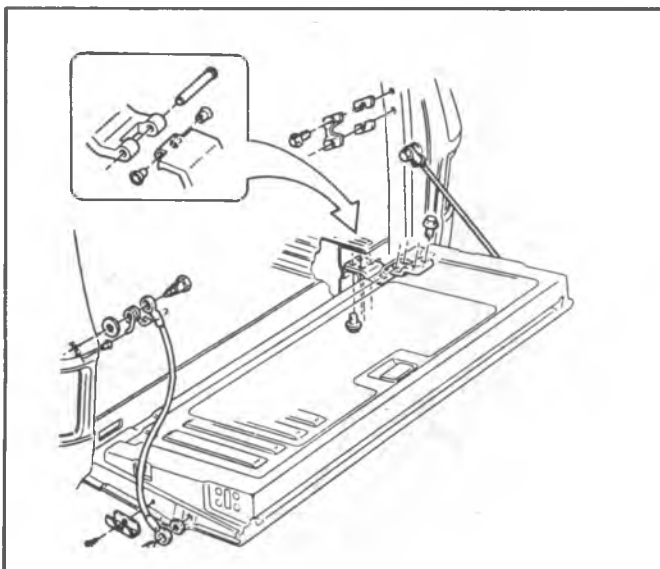

Fig. 2D-62--Endgate, Hinges and Support (Utility)

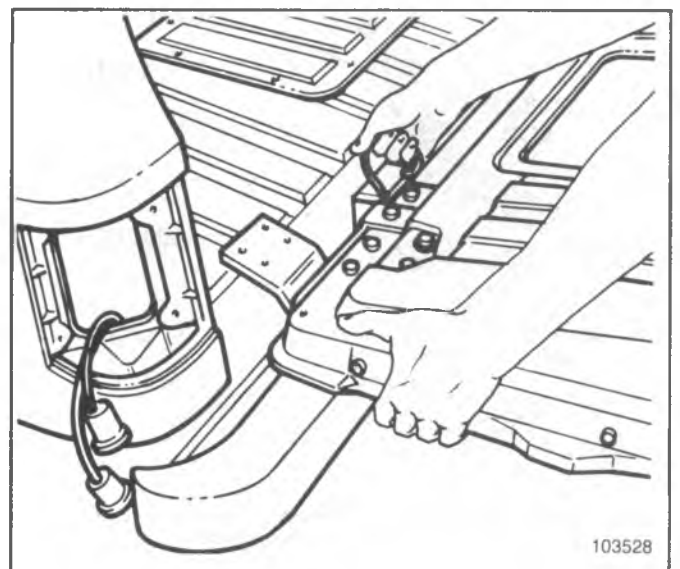

Fig. 2D-64--Grasping Torque Rod (Utility)

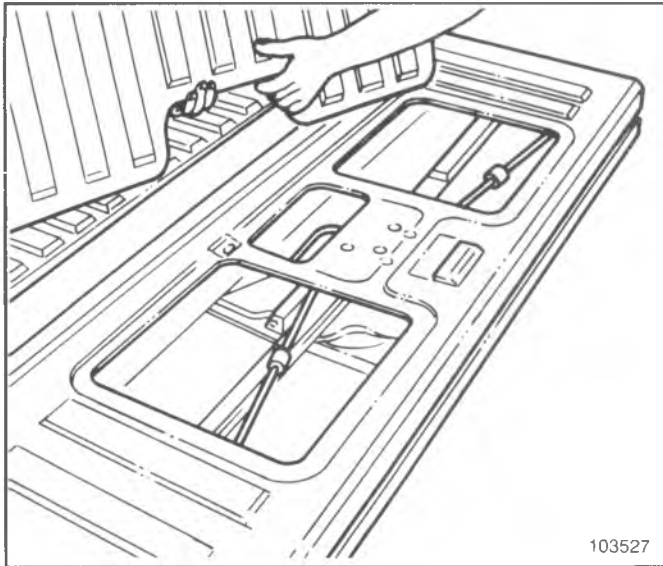

Fig. 2D-65--Removing Access Cover (Utility)

hinge-to-endgate bolts.

4. Pull the endgate away from the body several inches and withdraw hinge from body. Then lift endgate slightly to allow removal of hinge from endgate. See figure 2D-63.
5. To install hinge, reverse the above procedure. Be sure to install hinge into endgate first, then into the body.

## TORQUE ROD

### Replacement

1. Lower endgate and remove access cover, as shown in figure 2D-65.
2. Disconnect torque rod anchor plate. It is necessary to remove the lower bolt only, then let plate swing down. See figure 2D-66.
3. Loosen four bolts retaining endgate hinge to body.
4. Move endgate slightly away from body.
5. Remove torque rod retaining bracket on lower edge of endgate. See figure 2D-66.

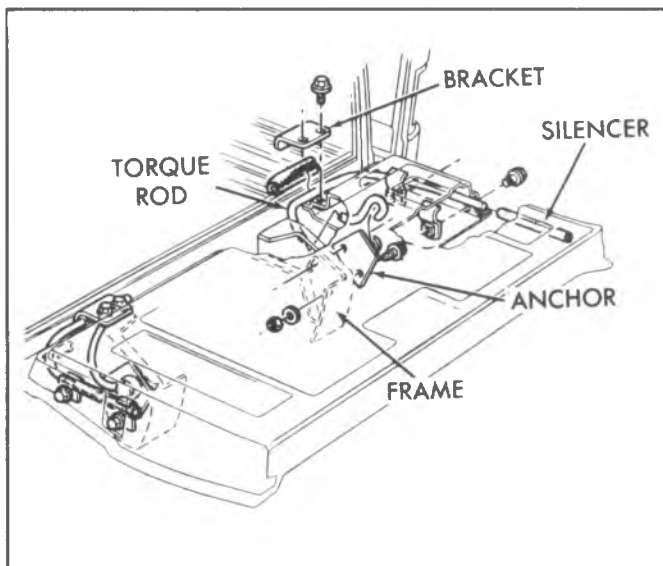

Fig. 2D-66--Torque Rod (Utility)

6. Remove torque rod retaining clip on side edge of endgate.
7. Lift torque rod up and slide from endgate as shown in figure 2D-67.
8. Reverse the procedure above for installation.

## ENDGATE DISASSEMBLY-UTILITY MODELS ONLY

### Manual Window

1. Lower endgate and remove access cover.
2. Disconnect side latch remote control rods from center control by removing retaining clips. See figure 2D-68.
3. Remove four screws from each side latch, and withdraw latch and control rod from endgate, as shown in figure 2D-69.
4. Disconnect control rod from latch.
5. Refer to figure 2D-70 for installation of latch control and blackout rod.
6. Disconnect blackout rod from control assembly by detaching spring and removing two screws retaining rod to inner panel.
7. Disconnect inside handle control rod from control assembly, then remove screws which secure inside handle to inner panel.
8. Remove three screws which retain remote control assembly to inner panel.
9. Remove control assembly and inside handle as shown in figure 2D-71.
10. Refer to figure 2D-72 for window and regulator installation.
11. Roll window to up position.
12. Disconnect sash from regulator as shown in figure 2D-73.
13. Remove glass from endgate.
14. Remove four regulator attaching screws and withdraw regulator from endgate as shown in figure 2D-74.

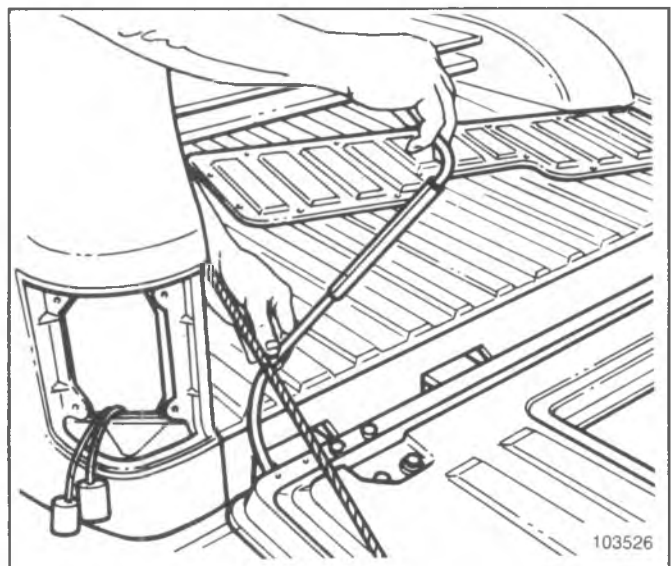

Fig. 2D-67--Removing Torque Rod (Utility)

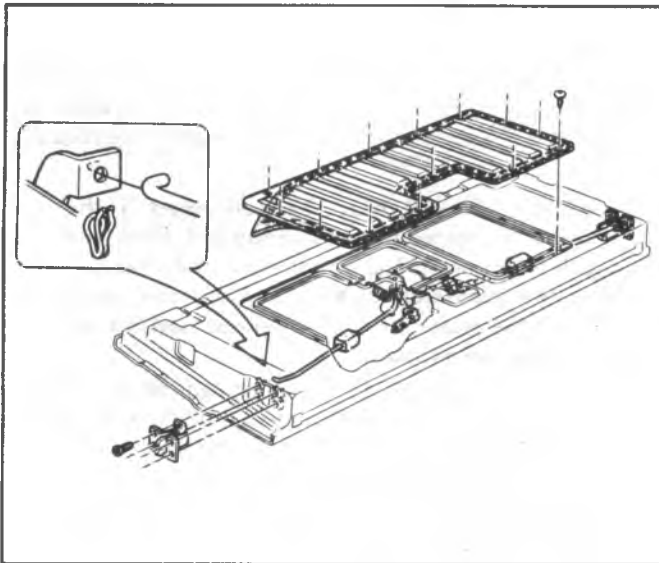

Fig. 2D-68--Latches and Rods

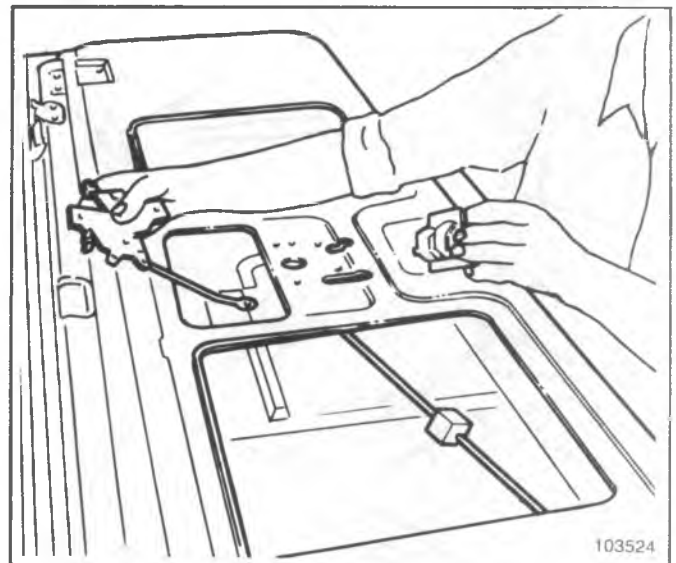

Fig. 2D-71--Removing Control Assembly and Inside Handle

103524

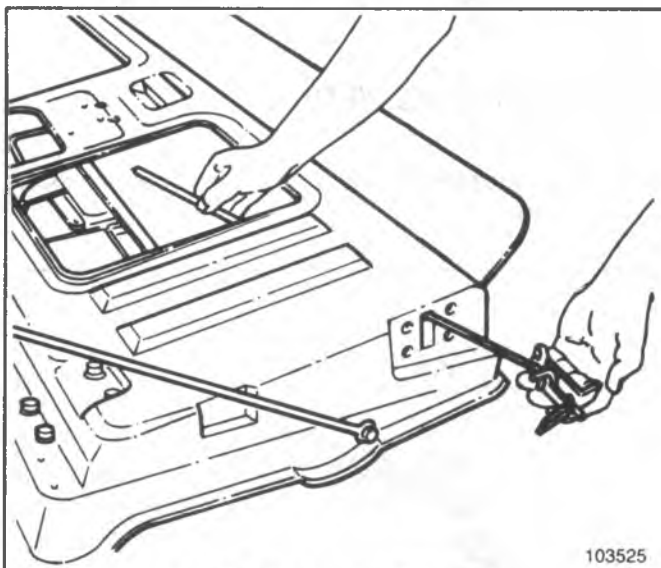

Fig. 2D-69--Removing Side Latch

103525

15. Remove outside handle by removing nuts from inside of outer panel. See figure 2D-61.

16. Reverse the above steps for reassembly.

### ELECTRIC WINDOW-UTILITY MODELS

The window is controlled by a jackscrew mounted to the regulator, drive cable and a 12V DC reversible motor mounted to the endgate inner panel. This circuit also includes a block out switch to prevent operation of the window while the endgate is open (fig. 2D-75).

Service procedures for endgate disassembly are the same as outlined above with the following exceptions:

#### Drive Cable

The drive cable can be replaced by disengaging the cable from the motor and jackscrew assembly and removing the cable. Reverse removal procedure to reinstall cable.

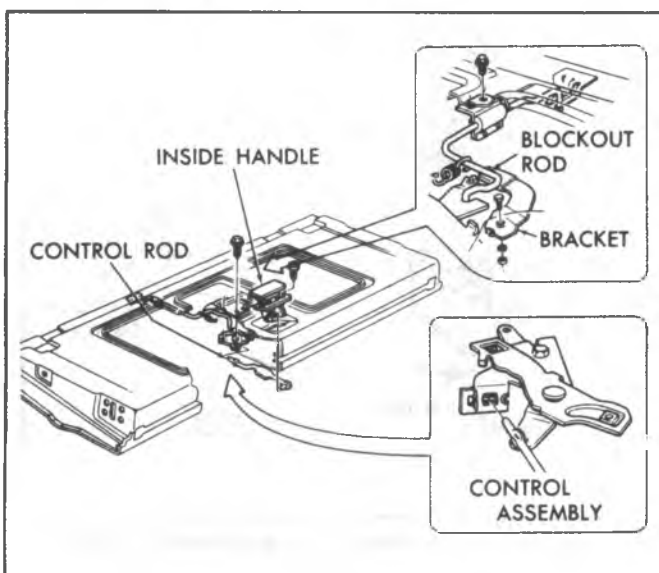

Fig. 2D-70--Control Assembly and Blockout Rod

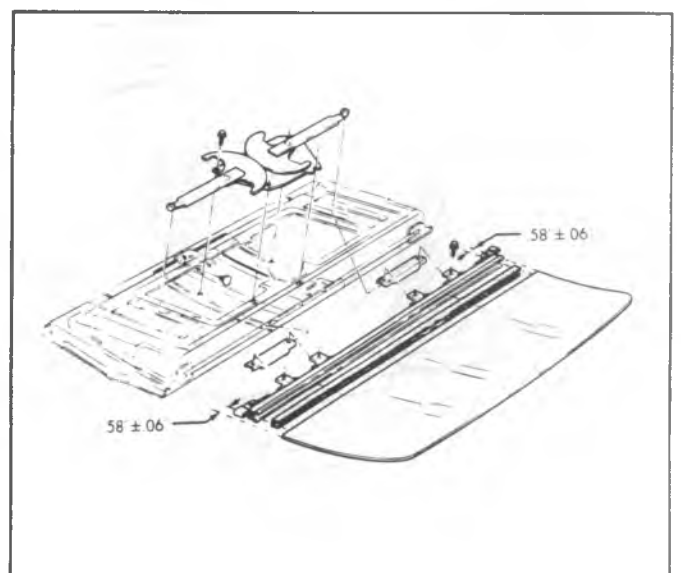

Fig. 2D-72--Window and Regulator

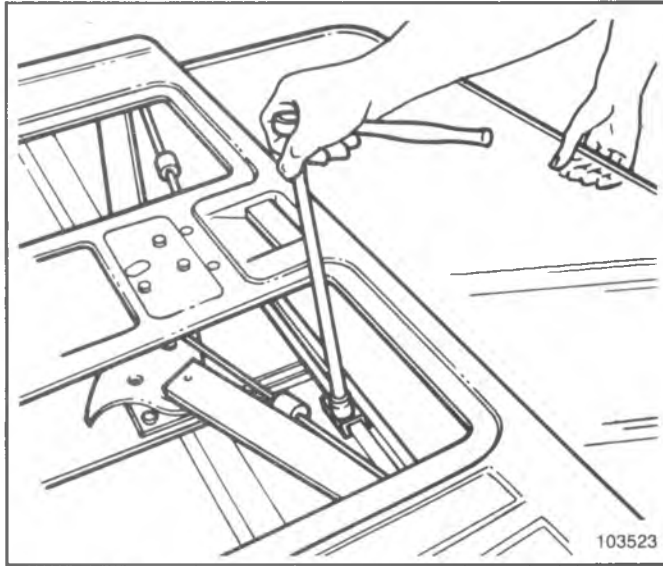

Fig. 2D-73--Disconnecting Sash from Regulator

**Motor (Fig. 2D-76)****Removal**

1. Disconnect drive cable from motor.
2. Disconnect wiring harness from motor.
3. Remove (3) motor attaching screws and remove motor.
4. To install, reverse removal procedure.

**Blockout Switch (Fig. 2D-75)****Removal**

1. Disconnect L.H. side latch remote control rod from center control by removing retaining clip.
2. Remove side latch retaining screws and disconnect blockout switch wiring.
3. Remove side latch assembly and remove screws retaining switch to side latch.
4. Reverse removal procedures for installation.

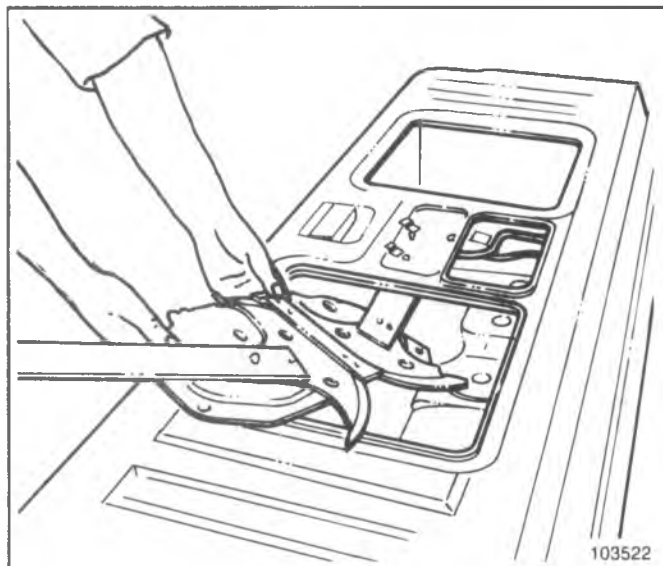

Fig. 2D-74--Removing Regulator

**Jackscrew (Fig. 2D-76)****Removal**

For endgates with electric window, secure the window regulator lift arms before removing the jackscrew when the window glass has been removed or disengaged from the lift arms.

**CAUTION:** Step 1 must be performed if the window is removed or disengaged from the regulator lift arms. The lift arms are under tension from the counterbalance spring, and can cause injury if the motor is removed without locking the sector gears in position.

1. Drill a 1/8 (3.1mm) inch hole through the sector gear and back plate. Install a sheet metal tapping screw into the hole to lock the sector gears in position.
2. Disconnect drive cable at jackscrew.
3. Remove the regulator jackscrew attaching screws and remove the jackscrew assembly.
4. Reverse removal procedure for installation.

**TAILGATES-PICKUP AND UTILITY MODELS****Fleetside****Handle Replacement (Fig. 2D-77)**

1. Open tailgate.
2. Remove screws attaching handle assembly to inner side of tailgate.

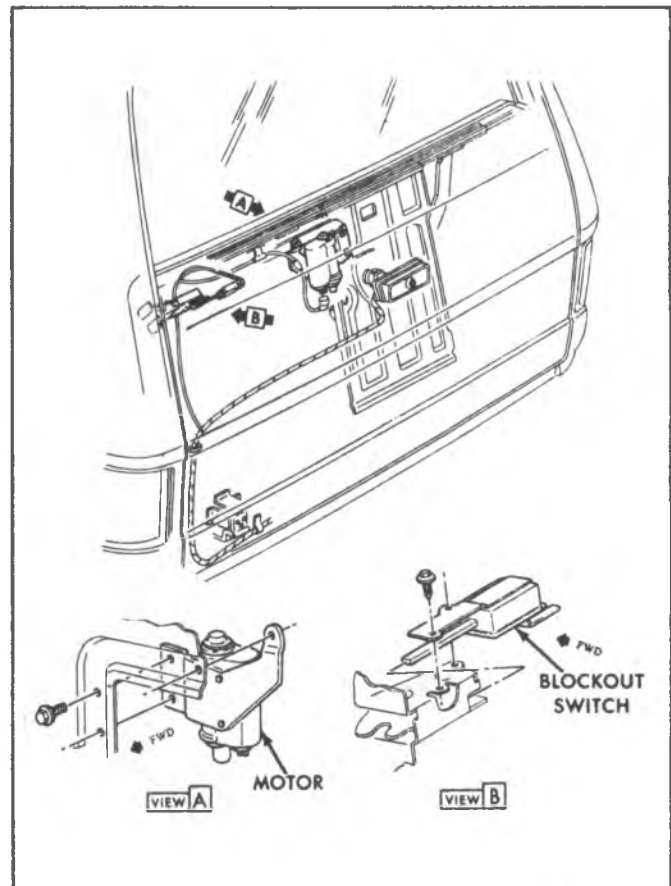

Fig. 2D-75--Power Window Motor and Switches (Utility)

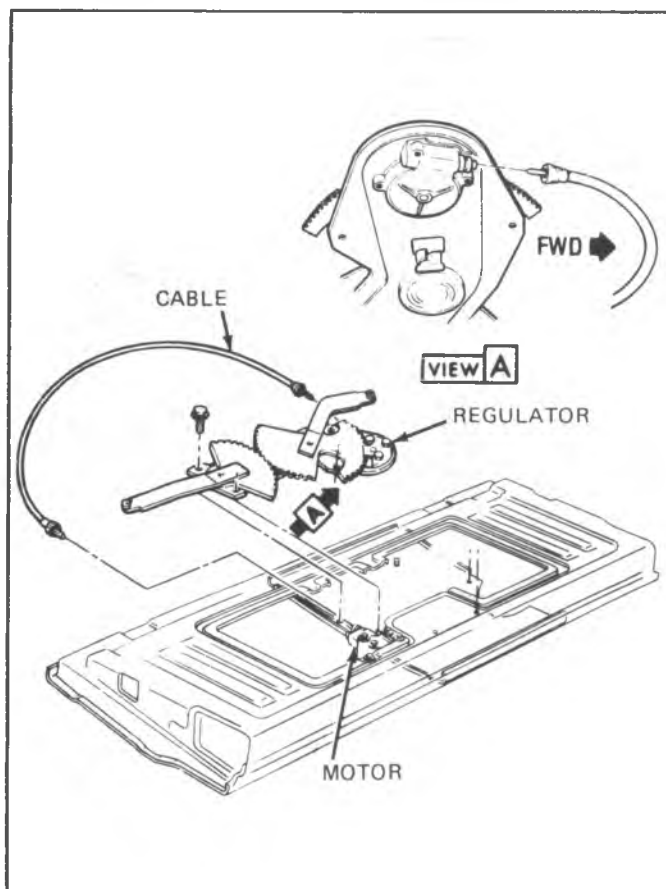

Fig. 2D-76--Endgate Regulator, Drive Cable and Motor

3. Remove clips from handle assembly and remove handle.
4. Remove screws from each latch assembly and lift off, with actuating rods.

**Replacement of Trunnion Assembly**

1. Lower tailgate half way.
2. Remove both retaining straps.
3. Lift up tailgate at the right side and pull out at the left side to remove tailgate assembly.
4. Remove two screws from trunnion and remove trunnion.

**Stepside**

**Endgate Replacement (Fig. 2D-77)**

1. Unhook endgate chain assembly at each side.
2. Remove bolt and lock washer from each trunnion in carrier box endgate.
3. Remove endgate.
4. Reverse procedure for installation. Align slot in trunnion to coincide with hole in endgate to permit using a tool to hold trunnion while tightening nut.

**REMOVABLE TOP-FOLDING TOP-UTILITY MODELS**

**Removal**

1. Remove access and disconnect courtesy light.
2. Lower the tailgate window and lower the tailgate.
3. Remove six top-to-roof mounting bolts.

4. Remove ten top-to-side panel mounting bolts (5 on each side).
5. Remove upper spare tire brace by removing brace bolt. The spare tire brace must be reinstalled after top is removed.
6. Remove only the rear attaching screws for the side trim panel (12 for LH panel and 11 for RH panel) so that the rear of panel can be pulled away to gain access for removal of hidden top bolt.  
If rear roll bar equipment is present, it is necessary to remove all the attaching screws, 20 on LH side and 19 on RH side, and the 1 bolt attaching the shoulder belt retractor located behind the access plate on retractor. Then the trim panel is raised and moved forward approx. 2-1/2 inches so that access can be gained through the cut out in trim panel to remove hidden top bolt.
7. With assistance, lift the top and move rearward for removal. The top should be removed carefully to prevent flexing of the sides and possible damage.

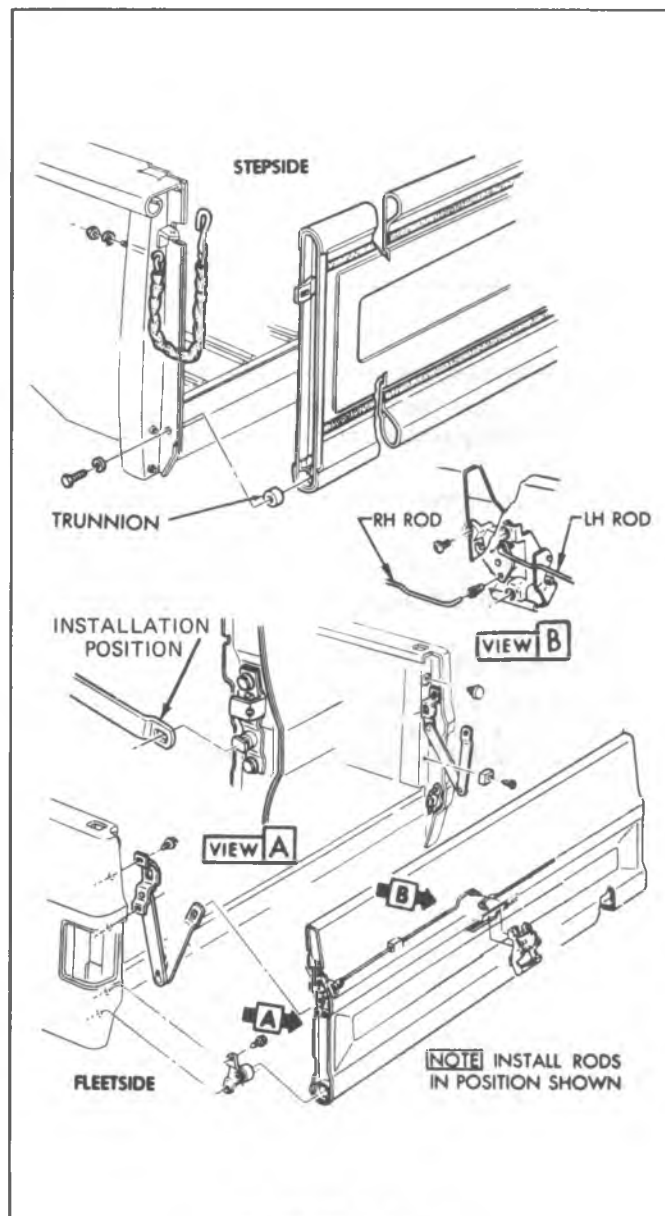

Fig. 2D-77--Tailgate

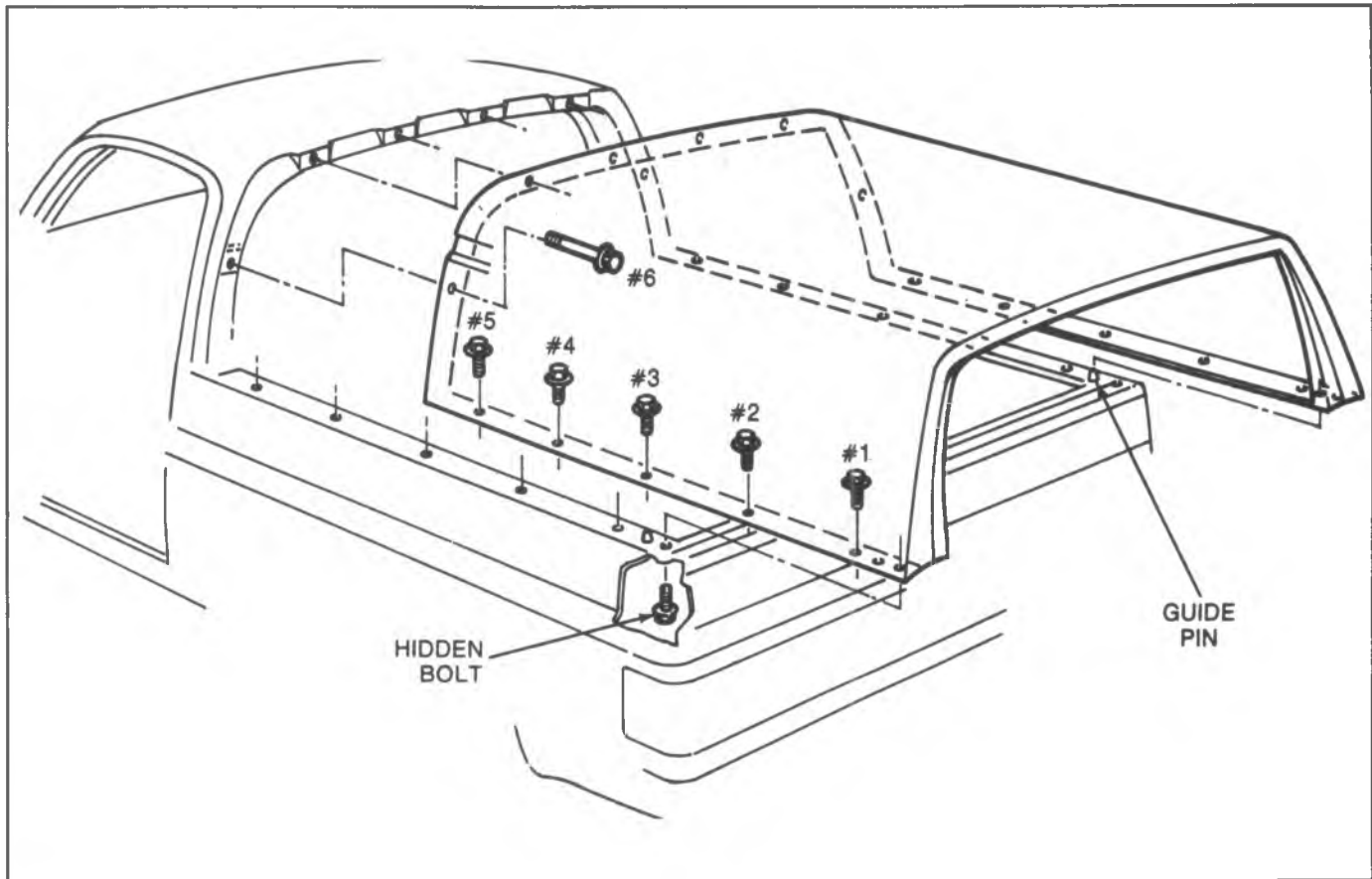

Fig. 2D-78--Removable Top

**Mandatory Assembly Sequence (Fig. 2D-78)**

To prevent possible damage to the top and to ensure proper weatherstrip sealing, the following procedure must be followed:

1. Remove the upper spare tire brace by removing (2) bolts.
2. Remove the necessary side trim panel screws.
3. Place top on box using the two rear guide pins as locators.
4. Install bolts #6 on both sides and tighten.
5. Bolting must start with the rear vertical bolt #1. Now going forward install #2 LH side only, #3 and #4. **The RH side #2 bolt will be installed later.**
6. Loosen bolts #6 on both sides.
7. Install and tighten bolts #5 on both sides.
8. Re-tighten bolts #6 on both sides.
9. Install and tighten remaining bolts to cab.
10. Install and tighten the 2 rear hidden bolts.
11. Install the side trim panel screws that were removed including the shoulder belt retractor bolt if it had to be removed.
12. Finally, reconnect the courtesy light and reinstall the upper spare tire brace using 2 bolts, with one of the bolts being the #2 R.H. top-to-side panel bolt.



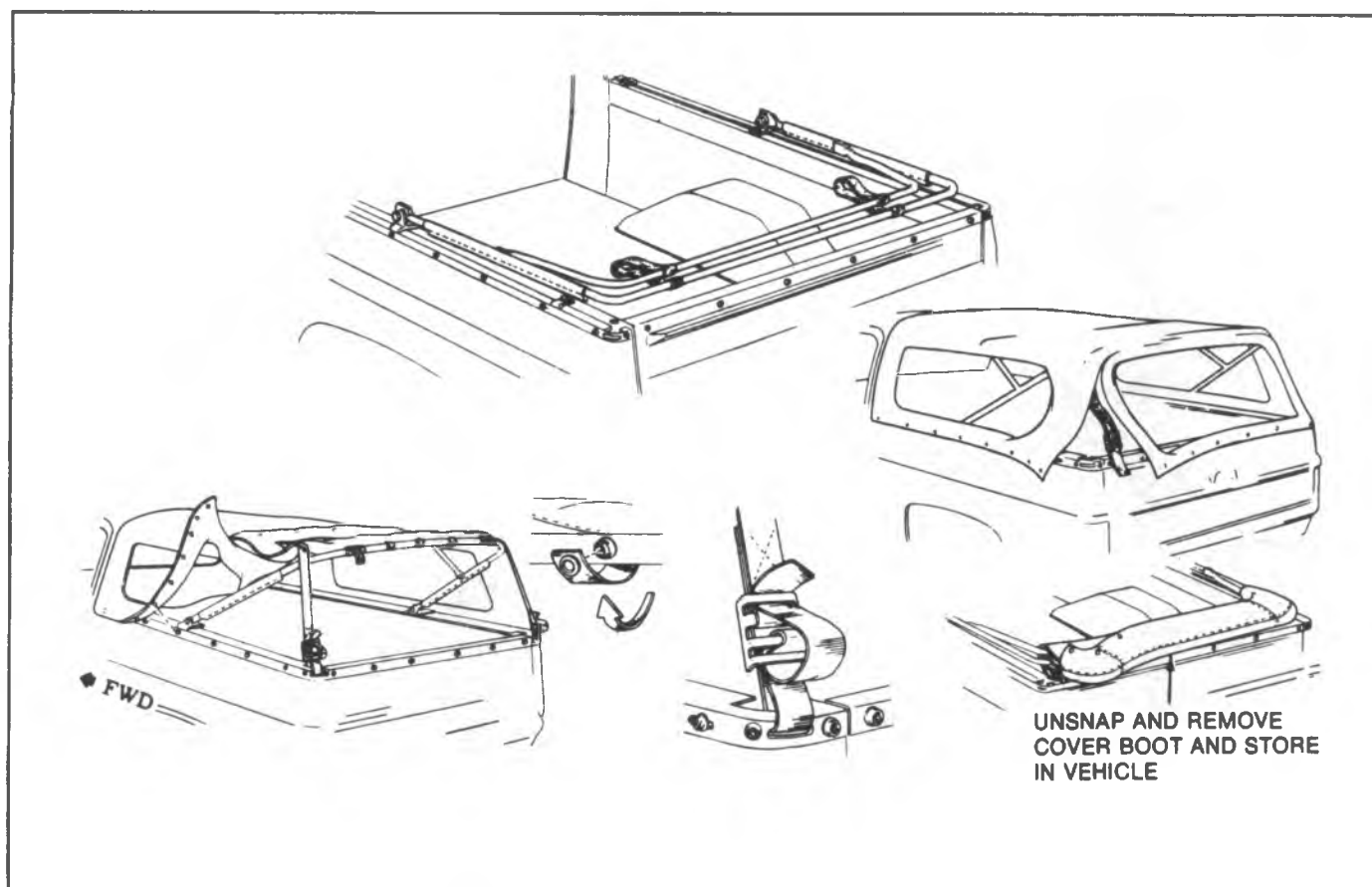

Fig. 2D-79--Folding Top Assembly

### LAP BELTS AND SHOULDER BELTS (ALL MODELS)

Before servicing or replacing lap and shoulder belts, including single loop belt systems, refer to the following precautionary items:

1. Lap and shoulder belts will be serviced as follows:
  - a. All belts will be serviced in complete sets.
  - b. Do not intermix standard and deluxe belts on front or rear seats.
2. Keep sharp edges and damaging objects away from belts.
3. Avoid bending or damaging any portion of the belt buckle or latch plate.
4. Do not bleach or dye belt or strap webbing (clean with a mild soap solution and water).
5. When installing lap or shoulder belt anchor bolt, start bolt by hand to assure that bolt is threaded straight.
6. Do not attempt repairs on lap or shoulder belt retractor mechanisms or lap belt retractor covers. Replace defective assemblies with new service replacement parts.
7. Do not attempt to remove seat belt retractor cover. The cover and the long rivet securing the cover to the retractor are not available as service replacement parts.

The shoulder belts and lap belts are attached to the front seat lap belt latch plate and connected to an inertia locking retractor installed to the floor or quarter inner panel above the right and left side of the front seat. The belts remain unlocked to allow occupants to move freely while the vehicle is being operated. When the vehicle decelerates or changes direction abruptly, the belts are locked in position by a pendulum that causes a locking bar to engage a cog of the retractor mechanism.

#### Removal and Installation

Refer to illustrations on following pages and select the appropriate illustration for removing and installing lap belts and shoulder belts.

Internal drive thread-forming anchor bolts are used to secure lap belts to the floor pan. To remove or install internal drive anchor bolts, use door lock striker and lap belt anchor bolt removal tool J-23457 or equivalent. Start bolt by hand to assure that bolt is threaded straight.

### SEAT MOUNTING

Typical Seat Mounting provisions are shown in figures 2D-83 through 2D-89.

**NOTICE:** See NOTICE on page 1 of this section regarding fasteners used on seats and seat belts.

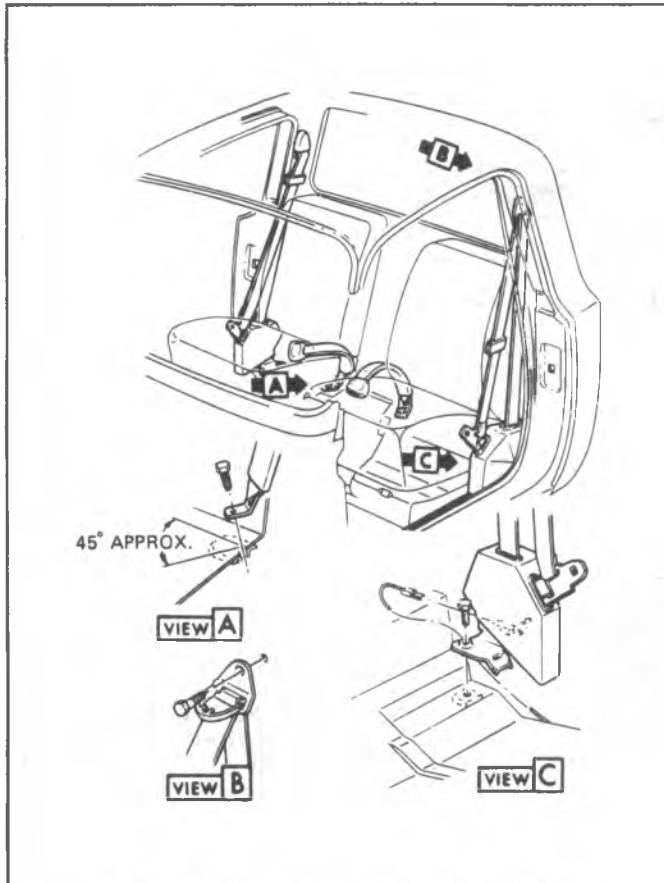

Fig. 2D-80--Seat Belt Installation (Chassis Cab)

### SEAT SEPARATOR COMPARTMENT

Figure 2D-90 illustrates assembly and installation of the CK model seat separator compartment.

### BODY MOUNTING

The removal of anyone bodymount necessitates the loosening of adjacent body mountings to permit the frame to be separated from the body. Care should be exercised to prevent breakage of plastic fan shroud, or damage to frame attachments such as steering column, brake pipes, etc., during replacement of body mounts.

During installation of a body mount, caution should be used to insure that the body mount is properly seated in the frame mounting hole, otherwise a direct metal to metal contact will result between the frame and body. The tube spacer should be in all bolt-in body mounts and the insulator or metal washer positioned to prevent contact with the frame side rail. Do not over-torque the body mount or a stripped bolt may result.

Do not use lubricants of any kind on the rubber parts of the mounts. Proper clamping by the mount depends on clean and dry surfaces. If the body mount bolt does not screw in

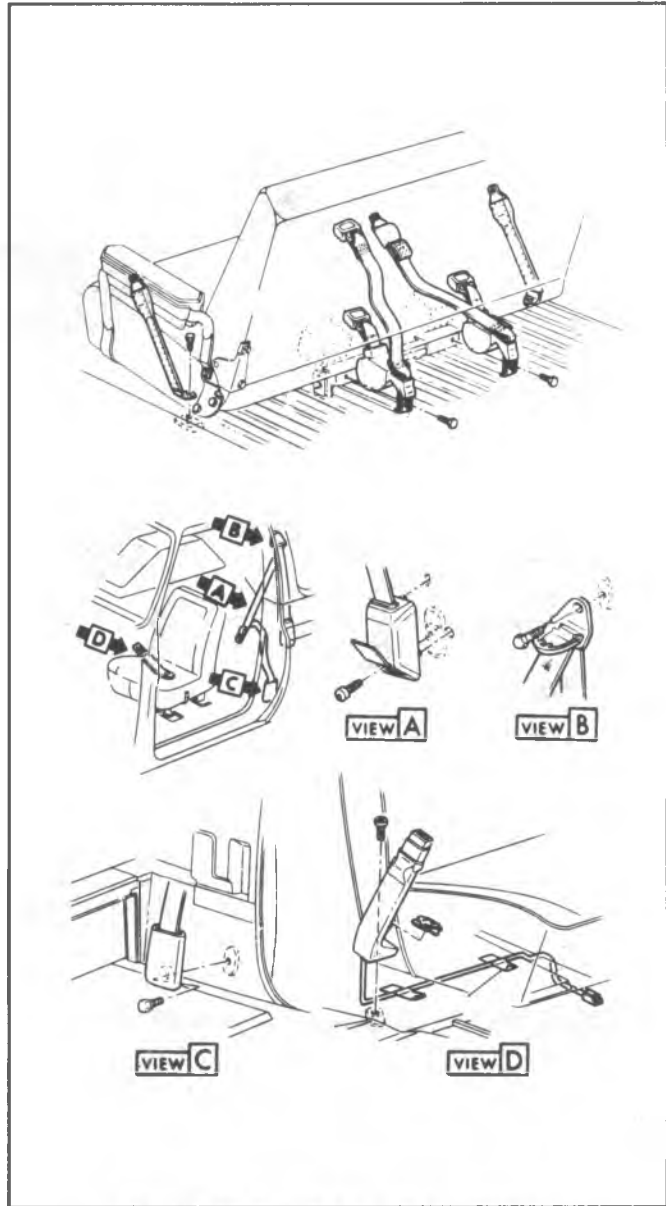

Fig. 2D-81--Seat Belt Installation (Utility)

smoothly, it maybe necessary to run a tap through the cage nut in the body to remove foreign material. Caution should also be used to insure that tap doesn't punch through underbody.

The sequence of mounting attachments is shown in figures 2D-91 through 2D-94.

### APPLIQUE PROCEDURES

Refer to Section 2C, Chassis Sheet Metal, for procedures relating to decal and woodgrain appliques.

### ADHESIVE BODY SIDE MOLDING

Refer to Section 2C, Chassis Sheet Metal, for procedures relating to installation of adhesive moldings.



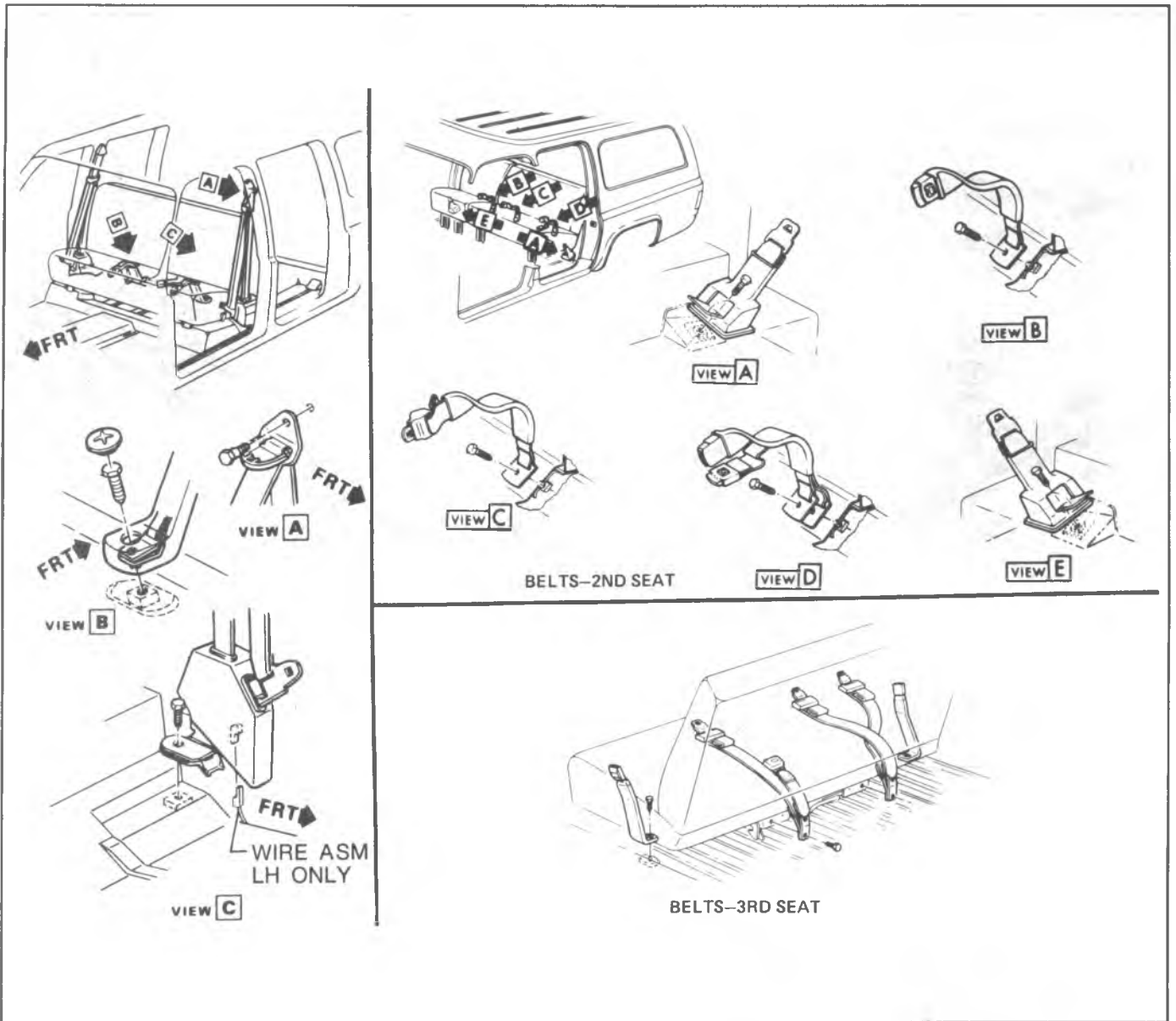

Fig. 2D-82--Seat Belt Installation (Suburban)

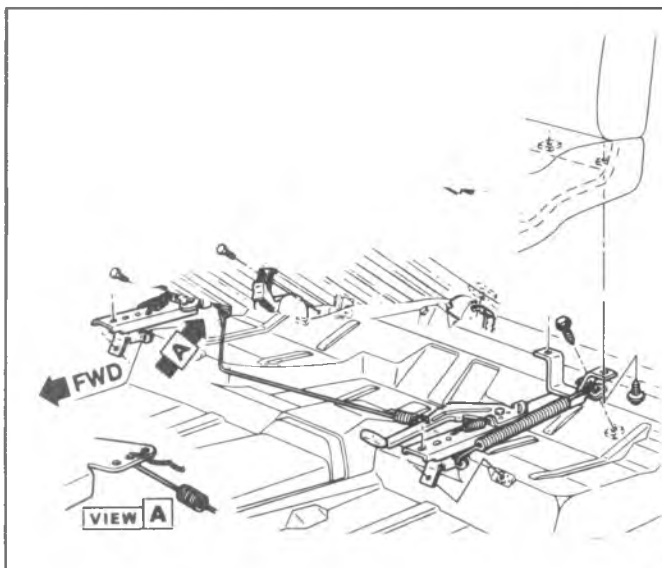

Fig. 2D-83--Front Bench Seat

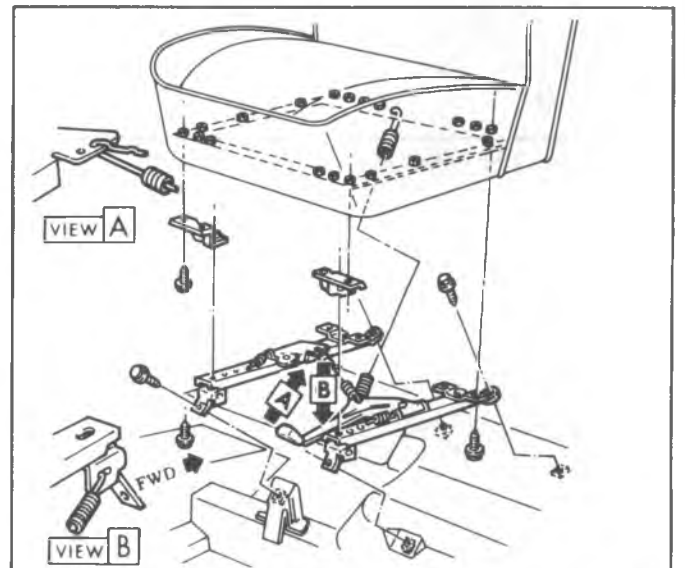

Fig. 2D-84--Driver's Bucket Seat (Chassis Cab) Passenger and Driver Seat (Suburban)

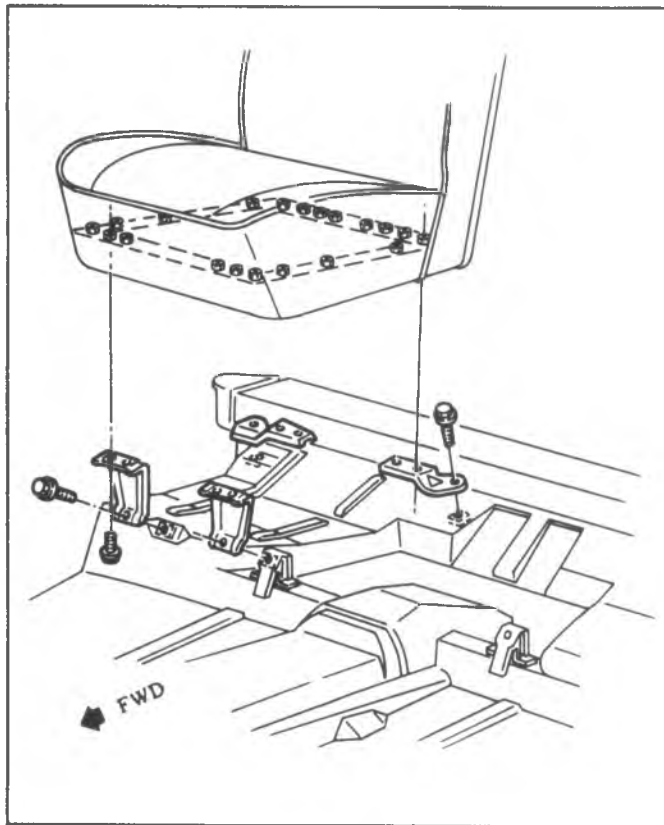

Fig. 2D-85--Passenger's Bucket Seat (Chassis Cab)

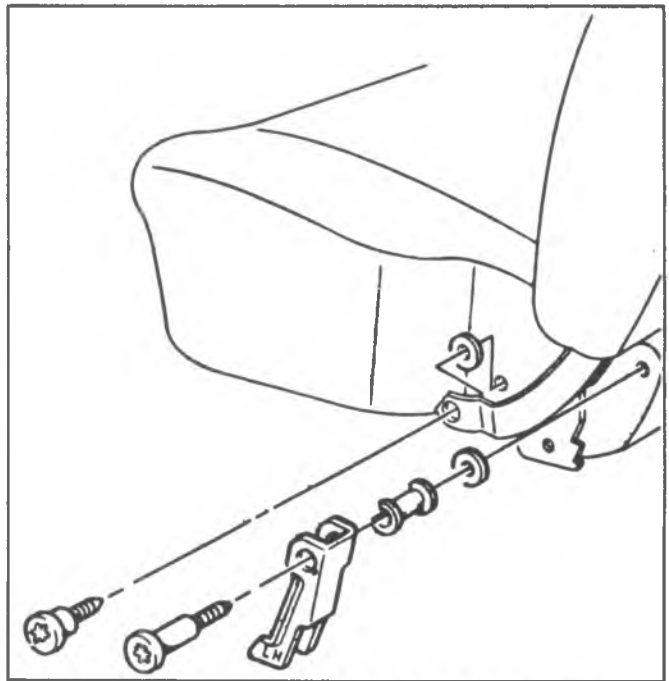

Fig. 2D-86--Folding Seat Back Catch and Striker

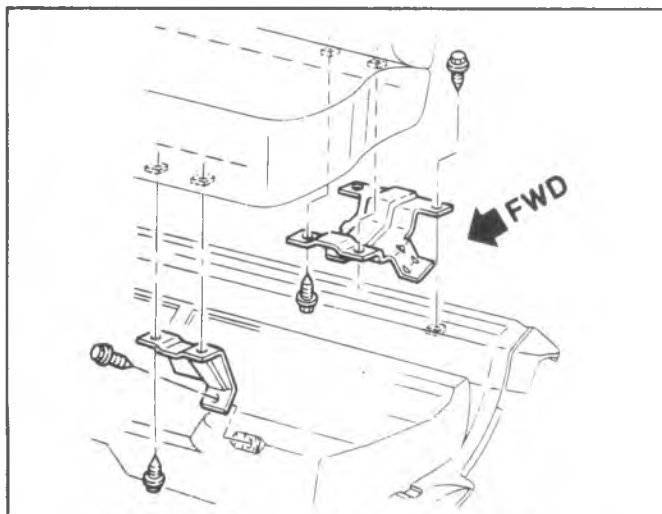

Fig. 2D-87--Rear Bench Seat (Crew Cab)

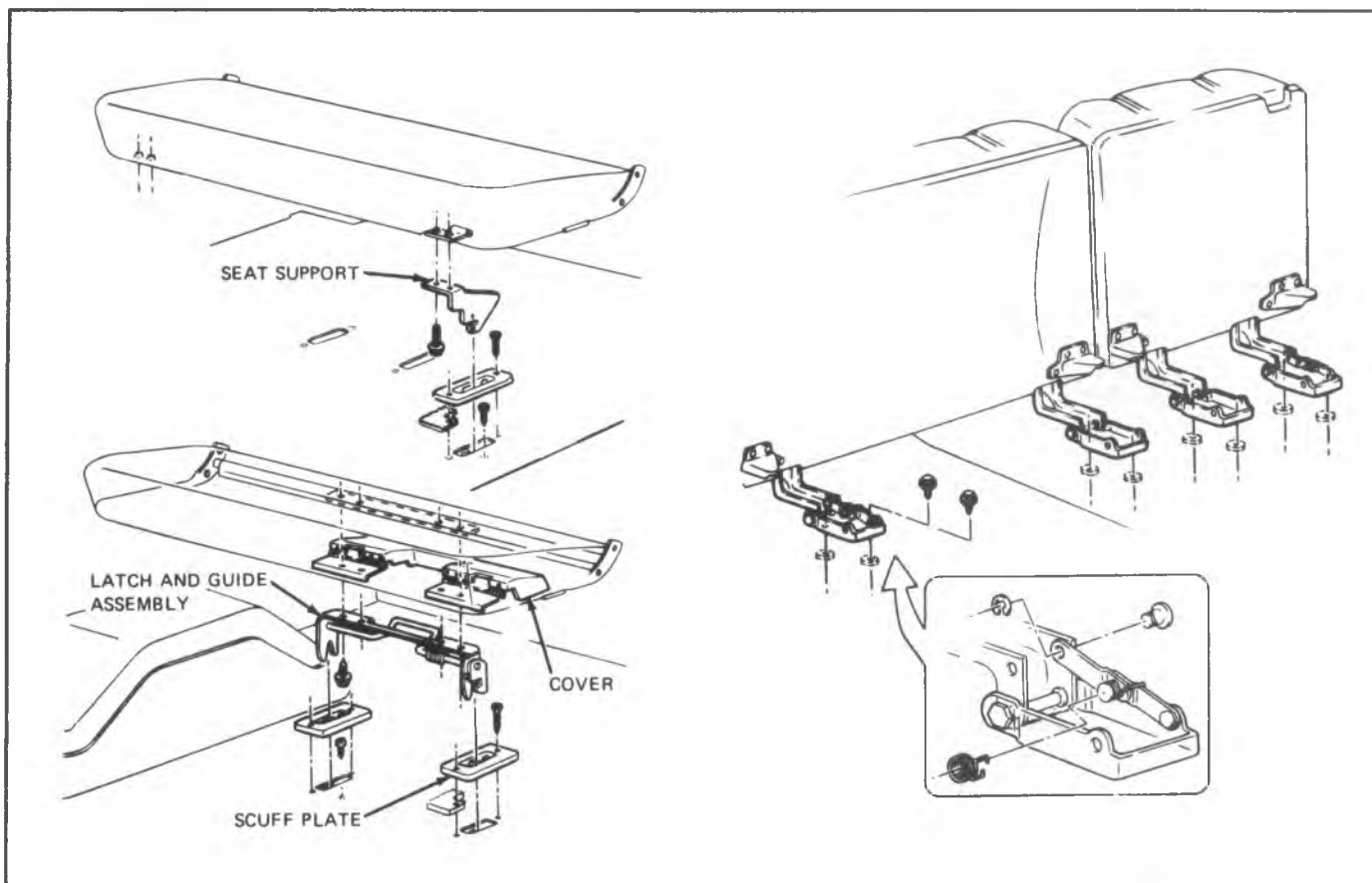

Fig. 2D-88--Rear Bench Seats (Suburban)

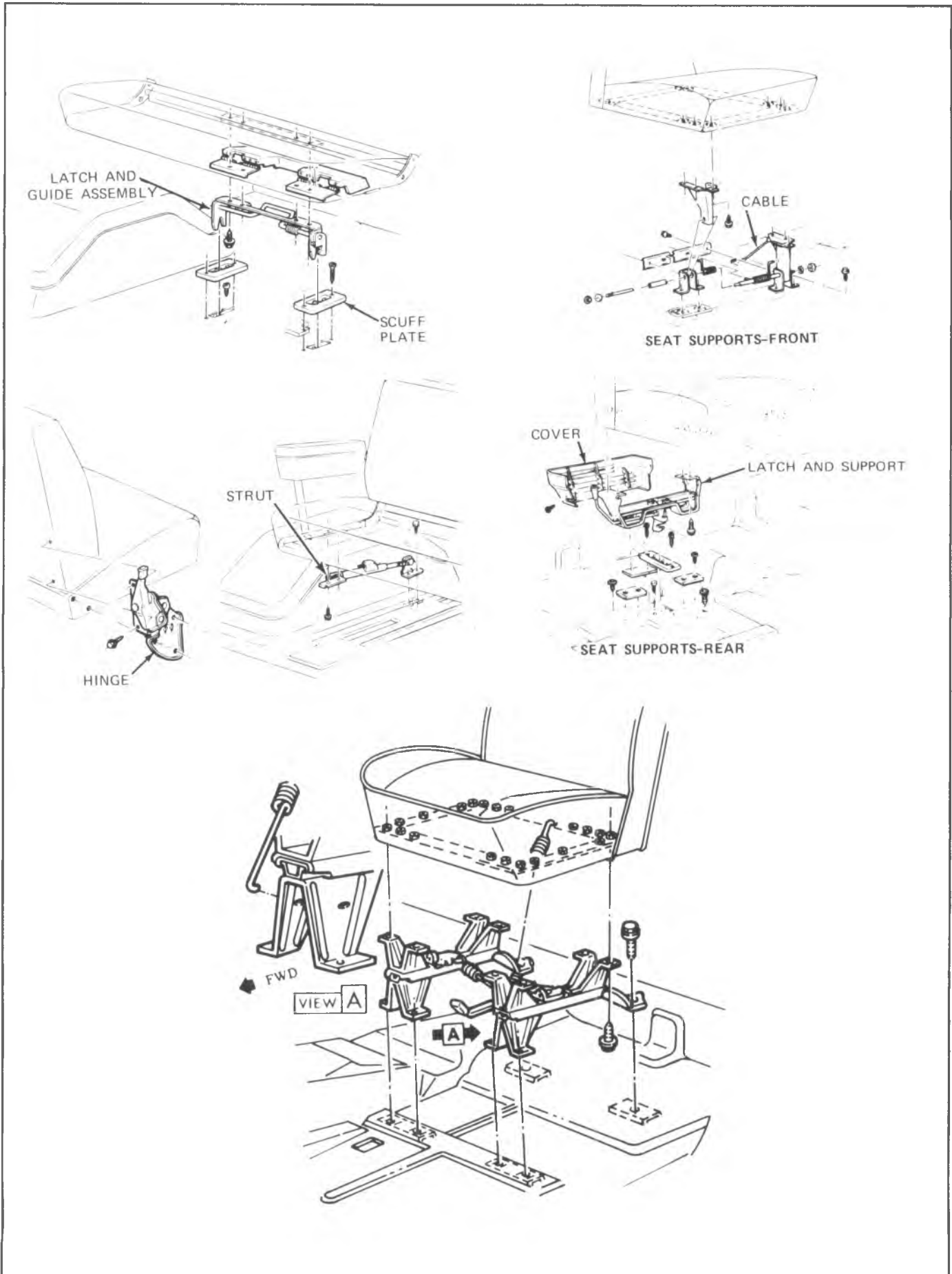

Fig. 2D-89-CK Utility Seat Attachments

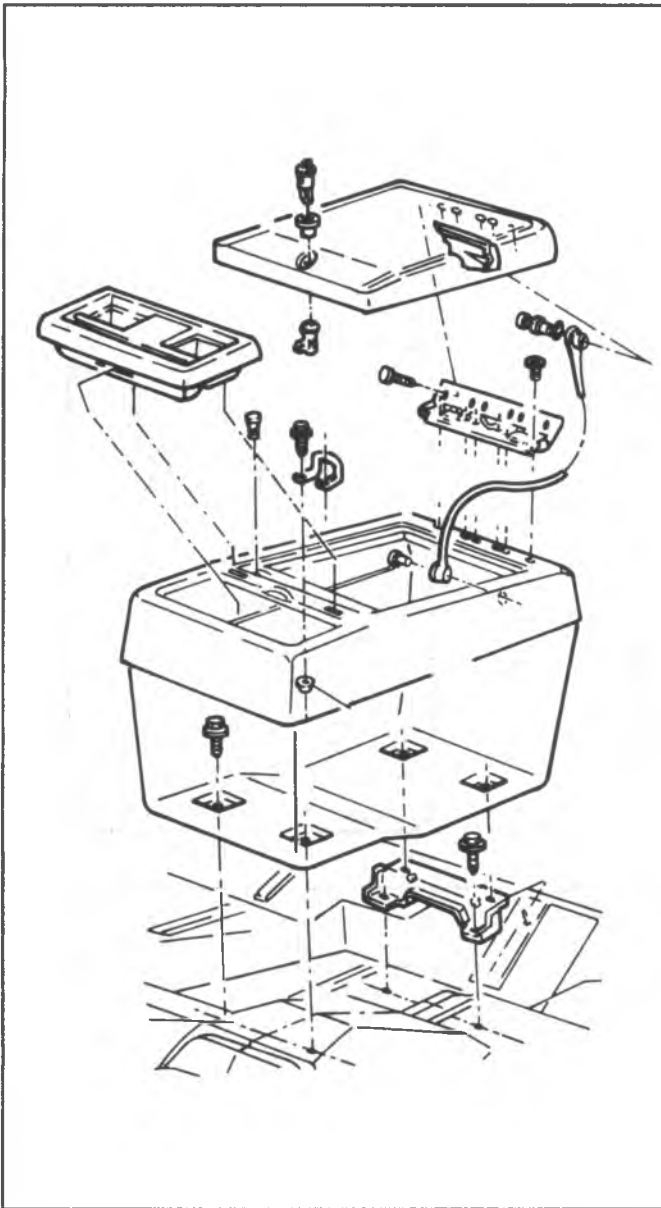

Fig. 2D-90--Seat Separator Compartment and Door--CK Models

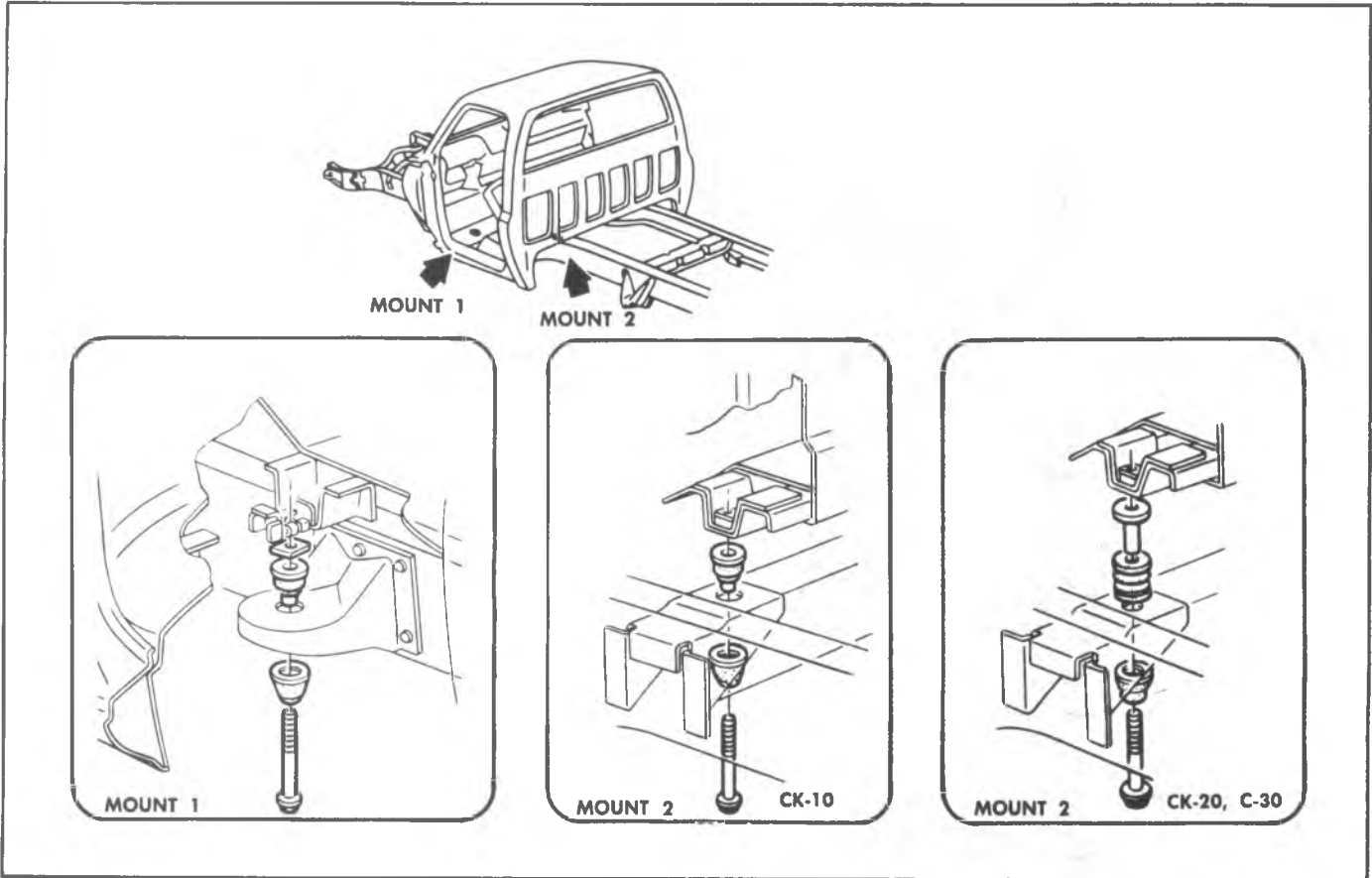

Fig. 2D-91--Body Mounting (Chassis Cab)

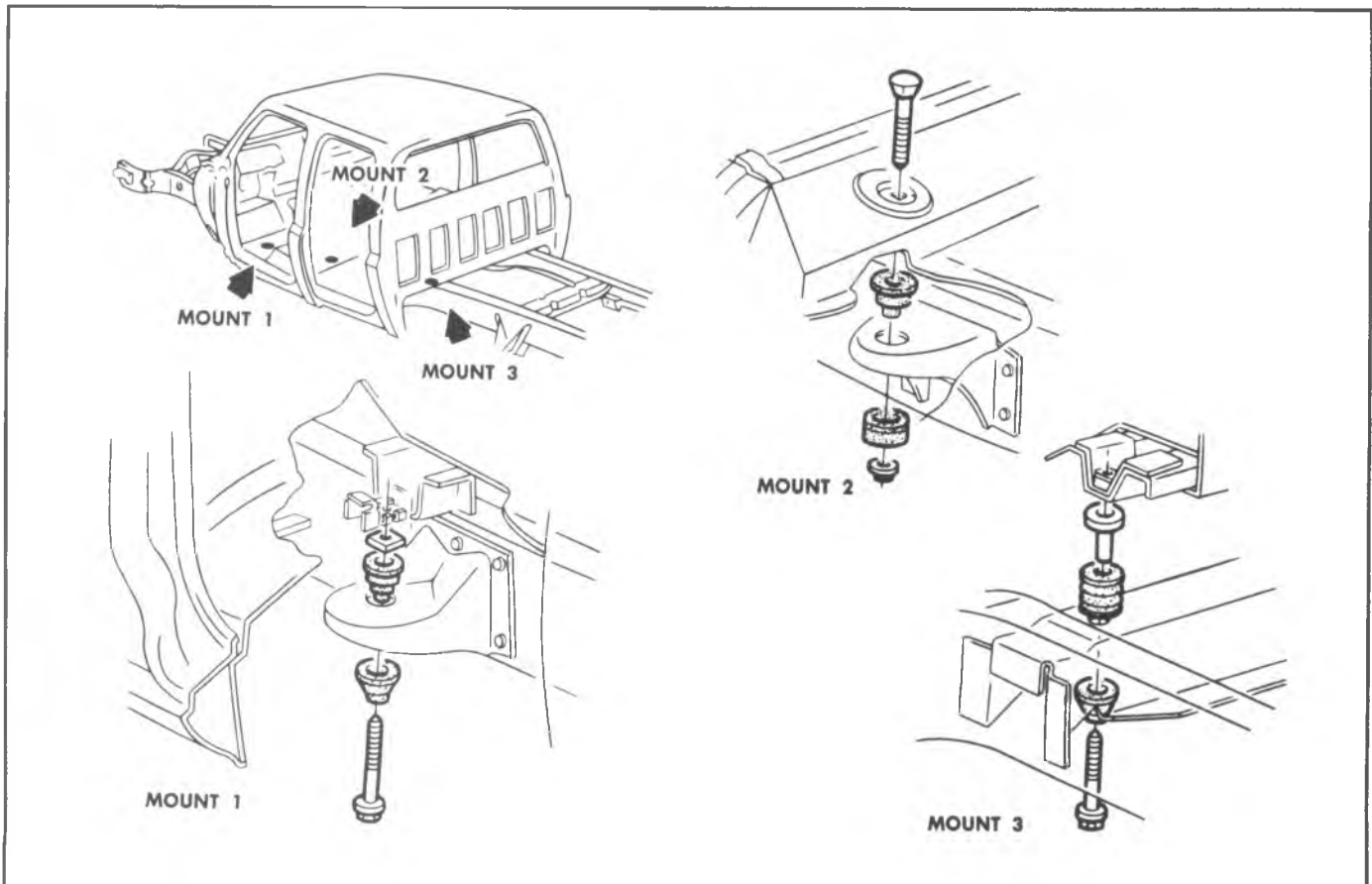

Fig. 2D-92--Body Mounting (Crew Cab)

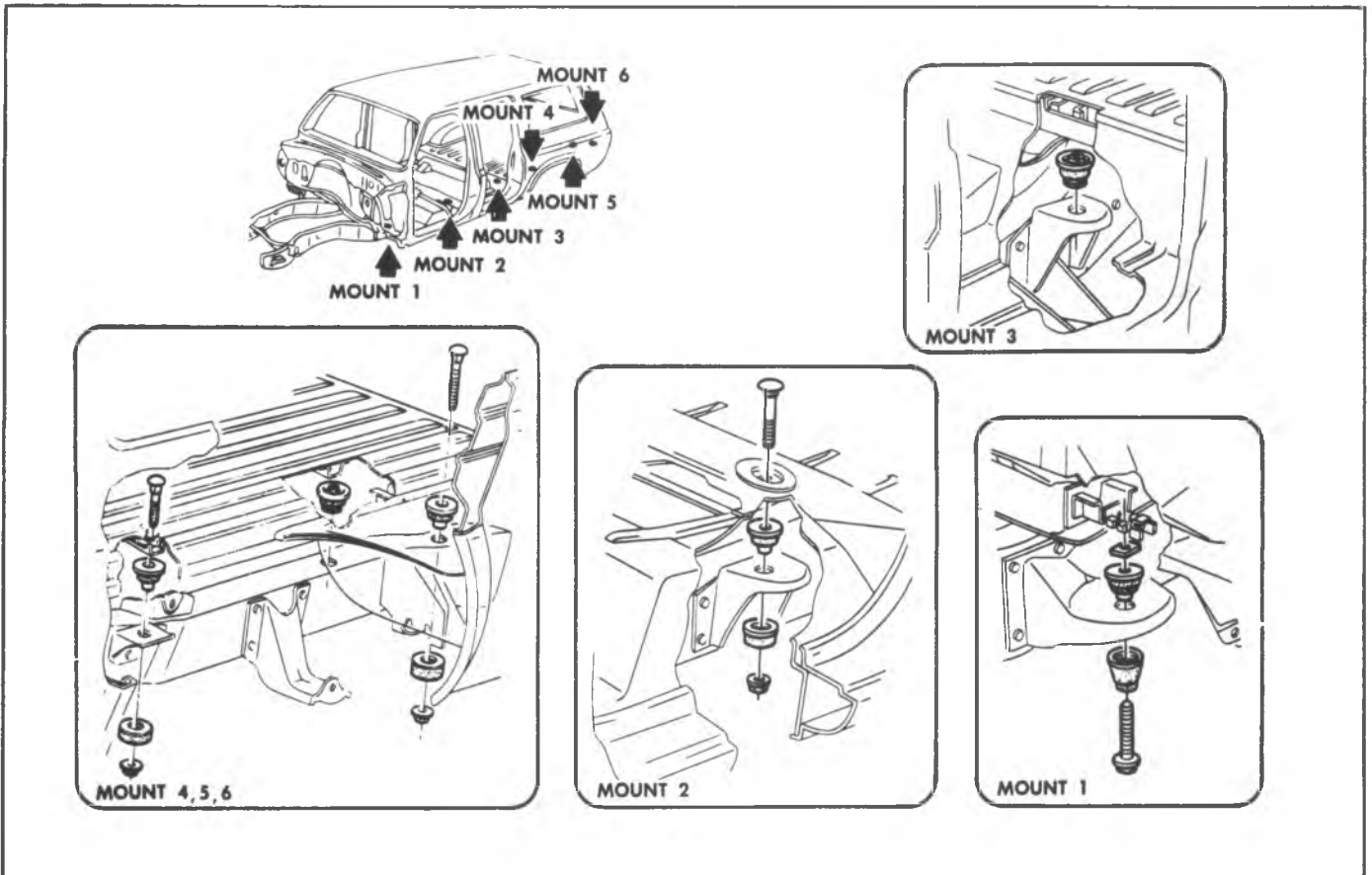

Fig. 2D-93--Body Mounting (Suburban)

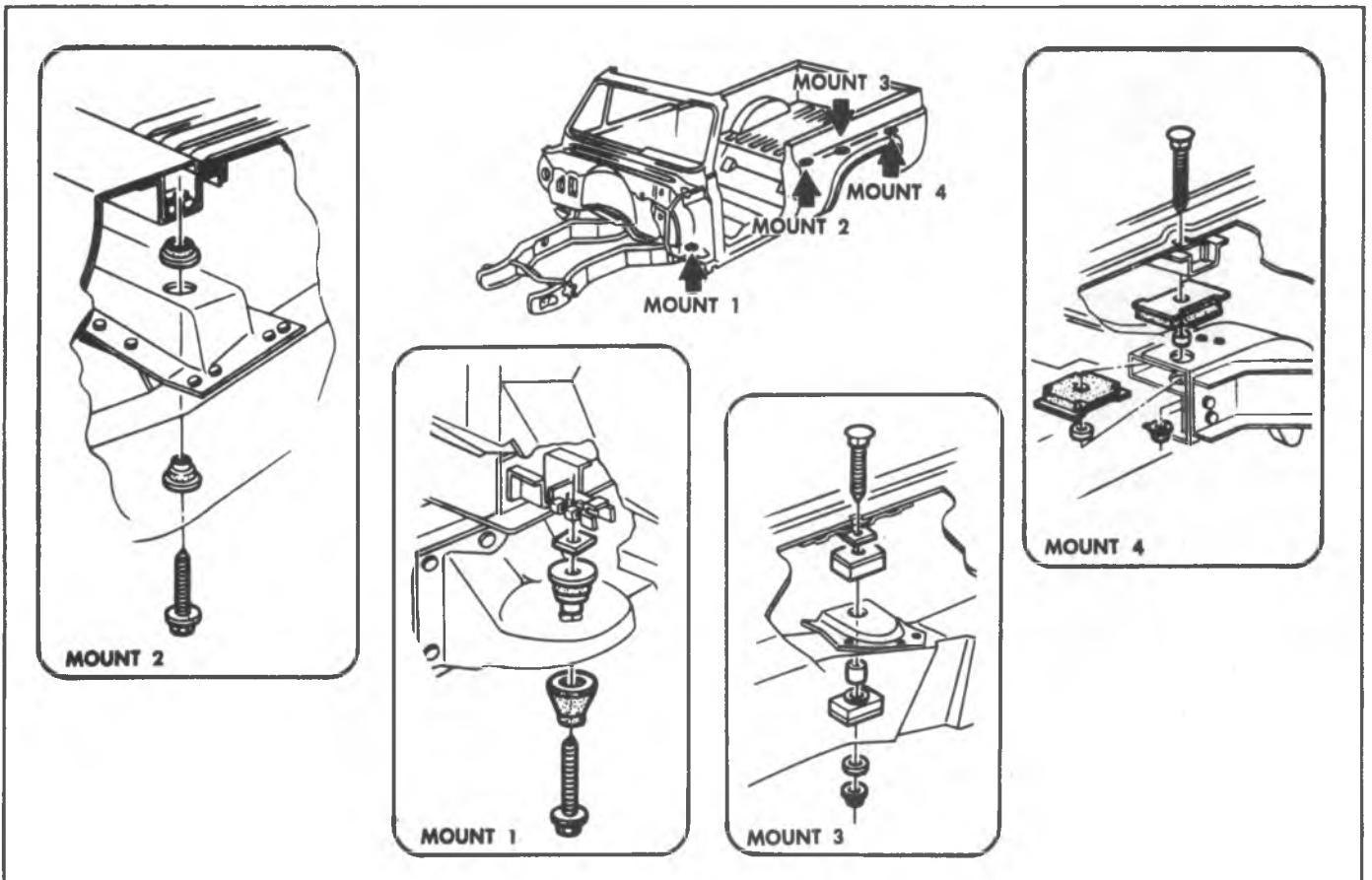

Fig. 2D-94--Body Mounting (Utility)

# G MODELS

## INDEX

|                        |       |                             |       |
|------------------------|-------|-----------------------------|-------|
| Front End              |       | Adjustments                 | 2D-51 |
| Windshield Wipers      | 2D-38 | Strikers                    | 2D-51 |
| Cowl Ventilator Grille | 2D-39 | Front Latch                 | 2D-53 |
| Side Ventilator Valve  | 2D-39 | Rear Latch                  | 2D-54 |
| Rear View Mirror       | 2D-39 | Upper Rear Hinge            | 2D-54 |
| Body Glass             |       | Rear Door                   |       |
| Windshield Glass       | 2D-40 | Hinge                       | 2D-56 |
| Swingout Glass         | 2D-44 | Remote Control              | 2D-56 |
| Front Door             |       | Latches and Rods            | 2D-57 |
| Adjustments            | 2D-44 | Adjustments                 | 2D-57 |
| Hinges                 | 2D-45 | Seats                       |       |
| Weatherstrip           | 2D-45 | Drivers Seat                | 2D-58 |
| Ventilator             | 2D-46 | Passenger Seat              | 2D-58 |
| Window Regulator       | 2D-47 | Rear Seats                  | 2D-59 |
| Locks, Handles, Rods   | 2D-48 | Roof Vent                   | 2D-59 |
| Sliding Side Door      |       | Seat Belts                  | 2D-59 |
| Description            | 2D-51 | Decal Applique Procedure    | 2D-59 |
|                        |       | Adhesive Body Side Moldings | 2D-59 |

## FRONT END

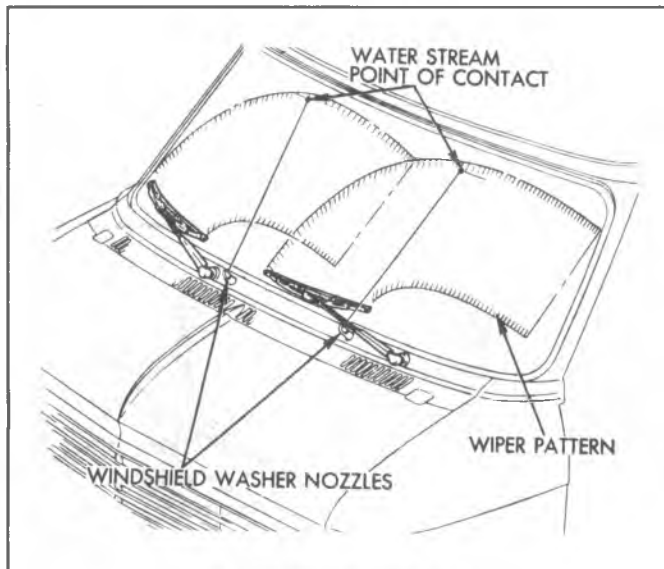

Fig. 2D-95--Wiper Pattern

### WINDSHIELD WIPERS

Windshield wiper units on all models are of the two-speed electric type. A single wiper motor unit, mounted to dash panel at top and to left of engine cover inside cab, powers both wiper blades. The wiper blade operating link rods and pivot mountings on these models are located in the outside air inlet plenum chamber.

#### Arm Adjustment

To adjust sweep of blades turn on wipers, then note sweep of arms. If necessary, remove one or both arms as follows:

Pull outer end of arm away from glass which will trip lock spring at base of arm and release spring from undercut of pivot shaft. While holding arm in this position, pull outward on cap section at base of arm to remove arm. Arm can be reinstalled in any one of several positions due to serrations on pivot shaft and in arm cap. See figure 2D-95.

### WIPER ARM PIVOT SHAFTS AND LINK ROD-FIG. 2D-96

#### Removal

1. Remove windshield wiper arms from pivot shafts. Procedure for removing arms is explained previously under "Arm Adjustments."
2. Remove screws which attach outside air cowl ventilator grille to cowl. Carefully remove grille from cowl.
3. At center of cowl, remove two attaching nuts which attach link rod to motor drive. Disengage link rods from pins.
4. Remove screws which attach each arm transmission pivot shaft assembly to cowl. Remove pivot shaft assembly with link rod from plenum chamber.

#### Installation

1. Place pivot shaft assembly with link rod into position at cowl bracket. Secure assembly to bracket with two screws.
2. Attach end of link rod to motor drive and arm. Secure rod with the two attaching nuts.
3. Install outside air cowl ventilator grille to top of cowl.
4. Before installing wiper arms, operate wiper motor momentarily which should rotate pivot shafts to park position. Install arms.



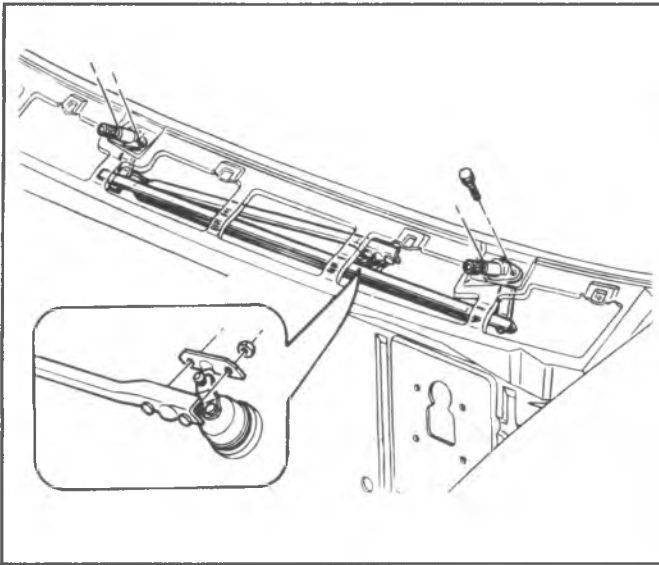

Fig. 2D-96--Windshield Wiper Linkage

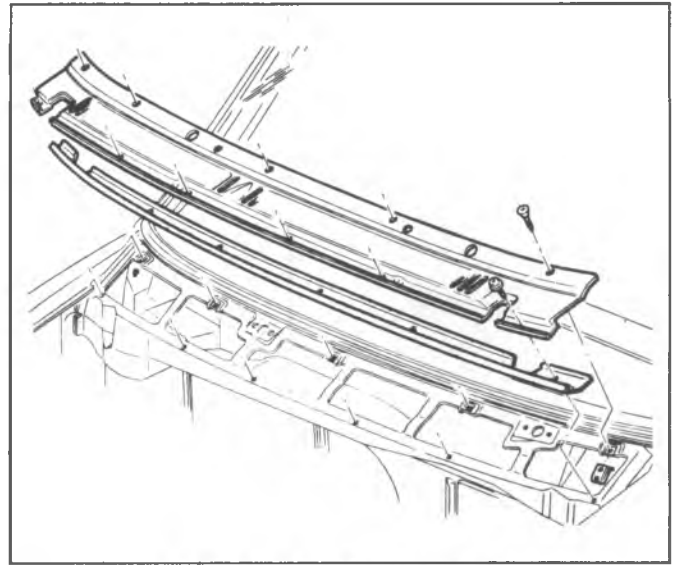

Fig. 2D-97--Cowl Ventilator Grille

**COWL VENTILATOR GRILLE**

**Replacement**

1. Remove windshield wiper arms.
2. Remove screws retaining grille, figure 2D-97.
3. Remove grille and seal.
4. Reverse above steps to install grille.

**SIDE COWL VENTILATOR**

**Replacement**

1. Remove screws retaining valve guide to panel, as shown in figure 2D-98.
2. Remove valve assembly by depressing pins at top and bottom of valve.

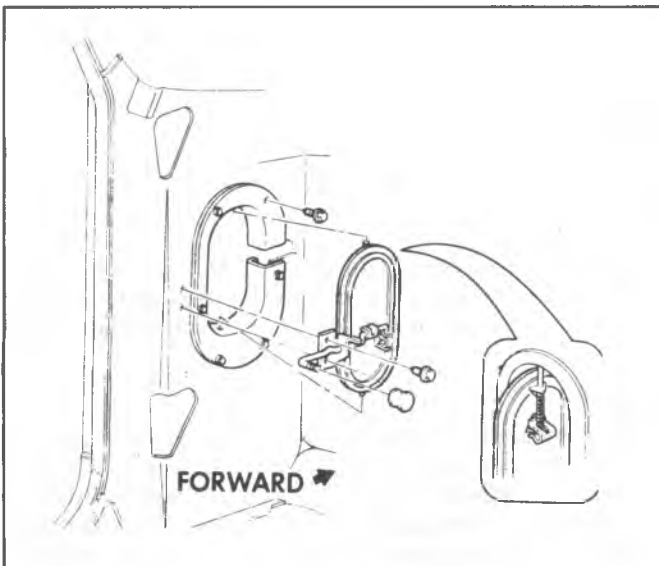

Fig. 2D-98--Side Cowl Ventilator

3. Reverse the above steps for installation.

**REAR VIEW MIRRORS**

**Inside Rear View Mirror**

**Replacement**

The inside mirror may be removed by removing screw retaining mirror to its glass-mounted bracket, and lifting mirror off bracket (fig. 2D-99).

**Outside Rear View Mirrors**

Outside rear view mirror installations are shown in figure 2D-100. Occasional tightening of mounting and assembly bolts and screws will sharply decrease occurrence of failure due to door slamming or road shock.

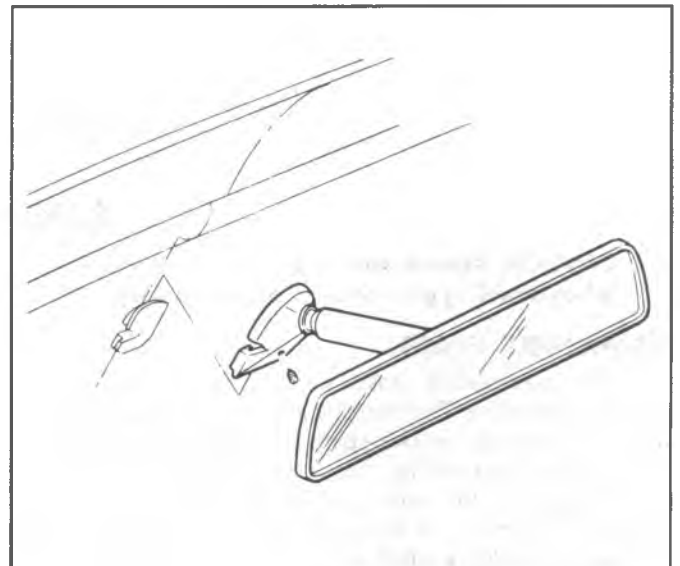

Fig. 2D-99--Inside Rear View Mirror

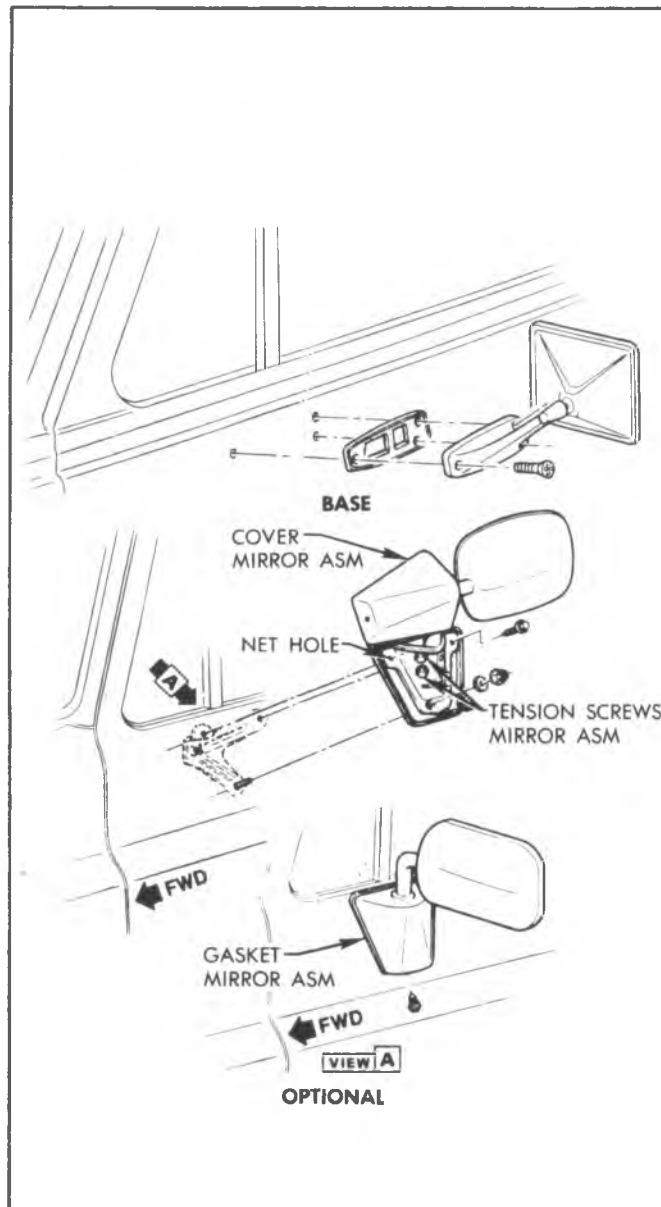

Fig. 2D-100--Outside Rear View Mirrors

## BODY GLASS

**CAUTION:** Always wear gloves and eye glasses when handling glass to avoid personal injury.

### WINDSHIELD GLASS

The windshield glass is retained to the body by urethane adhesive. The windshield reveal moldings are vinyl and are retained by two strips of butyl adhesive on the underside of the molding, attaching to the body on one side and the glass on the other and also by a retention lip in the urethane which retains the glass. The windshield rests upon the support molding which is secured to the pinchweld by a bead of butyl adhesive.

When replacing a cracked windshield glass, it is very important that the cause of the glass breakage be determined and the condition corrected before a new glass is installed. Otherwise, it is possible that a small obstruction or high spot somewhere around the windshield opening will continue to crack or break the newly installed windshield,

especially when the strain on the glass caused by this obstruction is increased by such conditions as wind pressures, extremes of temperature, motion of the vehicle, etc.

### Removal

There are two methods of windshield installation. The windshield removal procedure is the same for both installation methods with one exception. If the short method installation is to be used, more care must be used during removal to make certain that an even bead of adhesive material remains on window opening to serve as a base for replacement glass, there should not be any loose pieces of adhesive left in the opening. Cut away a sufficient amount of material to allow for the installation of the reveal moldings.

1. Place protective coverings around the area where the glass is being removed.
2. Remove windshield wiper arms, exterior reveal

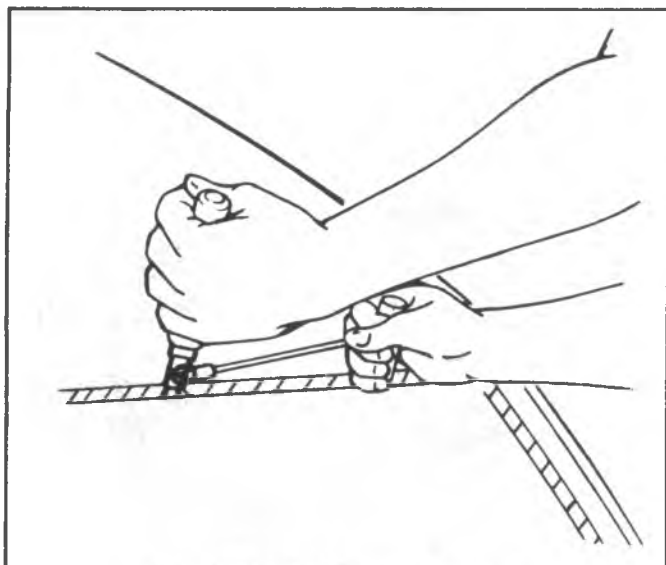

Fig. 2D-101 Knife Removal Method

moldings, interior garnish molding and support molding from the pinchweld. Clean up any remaining adhesive left on the body from the reveal molding.

**The reveal moldings can be removed from the urethane adhesive by taking one end of the molding and pulling it away from the adhesive. The support molding is removed in the same manner from inside the vehicle, pry up one end of the molding and pull it away from the pinchweld. These molding are to be removed prior to windshield removal.**

3. Use a knife as shown in Fig. 2D-101 to cut the adhesive completely around the perimeter of the glass. Knife, J-24402-A or equivalent may be used. With help from an assistant, carefully remove the glass.
4. If original glass is to be reinstalled, place it on a protected bench or holding fixture; remove old material using a razor blade or sharp scraper. Any remaining traces of adhesive material can be removed with denatured alcohol or lacquer thinner dampened cloth.

When cleaning windshield glass, avoid contacting edge of plastic laminate material (on edge of glass) with volatile cleaner. Contact may cause discoloration and deterioration of plastic laminate by wicking action. **DO NOT** use a petroleum base solvent such as kerosene or gasoline. The presence of oil will prevent adhesion of new material.

When replacing the windshield, urethane adhesive (part no. 9631000 or Essex SCD 551.2 or equivalent) **must** be used in order to maintain original installation integrity.

The short method as described previously can be used where original adhesive material left on window opening pinchweld flanges after glass removal serves as a base for the new adhesive to the glass. This method would be used in cases of cracked windshields or removal of windows that are still intact. The amount of adhesive left in window opening can be controlled during glass removal.

However, in some instances all the material must be removed, to make a metal repair or to perform a paint-refinishing operation. In these cases, an additional cleaning and priming step is required before applying the urethane

adhesive. See the instructions at the beginning of "Installation".

#### Adhesive Service Kit or Cartridge

Material listed have a short shelf life. Be sure materials are fresh.

Urethane adhesive cartridge Essex SDC 551.2 or the equivalent are provided singularly. Adhesive Kit No. 9631000 (urethane adhesive) or equivalent contains some of the items needed to remove and replace a urethane adhesive installed glass.

Additional items required:

1. Pinchweld primer for enamel painted surface Essex SCD 435.34 or equivalent.
2. Clear glass primer, Essex SCD 435.18 or equivalent.
3. Black glass primer (included in kit 9631000) or Essex SCD 435.20 or equivalent.
4. Solvent for cleaning edge of glass (preferably alcohol) and adhesive dispensing gun No. J-24811 or an equivalent standard household cartridge type gun reworked as follows:
  - a. Widen end slot to accept dispensing end of adhesive material tube.
  - b. Reduce diameter of plunger disc on rod so that disc can enter large end of adhesive material tube.
5. Commercial type razor knife.
6. Urethane cutting knife No. J-24402-A or equivalent or two pieces of wood for wire handles.
7. Two rubber support spacers.

#### Installation

Steps 1 through 11 are to be used for installing glass onto the original urethane adhesive left behind when the windshield was removed. In those instances where the adhesive was entirely removed, to make a metal repair or to perform a paint refinishing operation, it is necessary to follow this extra step, before starting Step 1.

- Thoroughly clean the metal area surrounding the windshield opening by wiping with a clean alcohol-dampened cloth. Allow to air dry. Then apply primer for enamel painted surface Essex SCD 435.34 or equivalent, to the same area, being careful not to allow any spill over onto exposed paint surfaces as this primer will damage the paint finish. The surface should not exceed 38°C (100°F) at the time of the application. Refer to Fig. 2D-102. Allow the primer to dry for thirty minutes.

1. From inside the vehicle, install the support molding onto the pinchweld flange, the joint is to be located at bottom center of the opening. See Fig. 2D-103.
2. Thoroughly clean the edge of the glass to which the adhesive material will be applied by wiping with a clean alcohol-dampened cloth. Allow to air dry.

When replacing the windshield, urethane adhesive Part No. 9631000 or Essex SCD 551.2 or equivalent must be used in order to maintain original installation integrity.

3. Apply clear glass primer, Essex SCD 435.18 or equivalent around the entire perimeter of glass edge. Refer to Fig. 2D-102.
4. Apply the black glass primer in the urethane

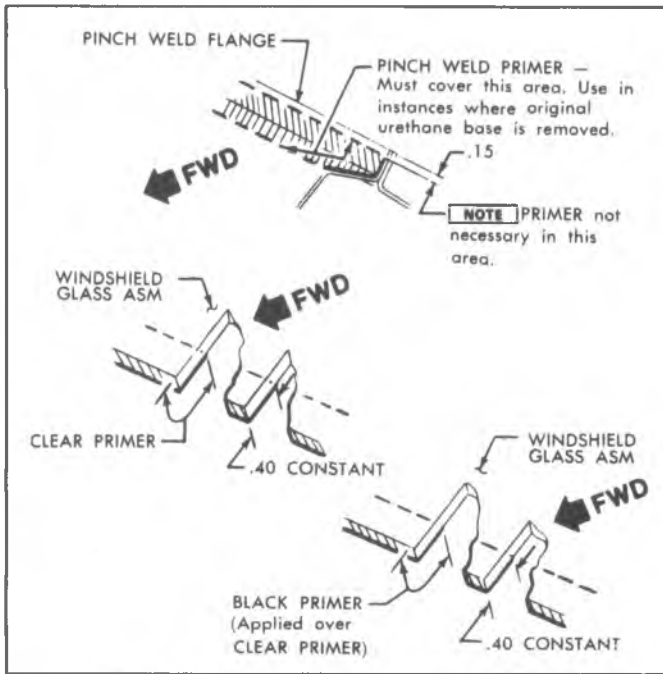

Fig. 2D-102 Windshield Installation Preparation

adhesive kit 9631000 or Essex SCD 435.20 or equivalent around the entire perimeter of the glass edge. Allow to dry to touch (approximately 10 minutes). Refer to Fig. 2D-102.

5. With the aid of a helper, lift the glass into the opening. Carry the glass with one hand on the inside of glass, and one hand on the outside. At the windshield opening, set the glass in a horizontal position. While one partner holds the glass in this position, the other can reach one arm around the pillar and support the glass from the inside, while the first person assumes the same position. With the glass centered in the opening, place the glass against the inside support molding, use small rubber blocks to support the glass in the correct position. Use the last screw on either side of the cowl grille cover as a guide for the positioning of these blocks in the windshield opening. Be sure to center the glass so that gaps on opposite sides and top-to-bottom are equalized. Trim rubber blocks as necessary. If the short method is used, check reveal molding fit and cut away additional solidified urethane base as necessary. See Fig. 2D-104.
6. Cut the tip of the adhesive cartridge to make a small opening of approximately 3/16 inch. First, fill in behind and around spacer blocks with urethane.
7. Then apply a smooth, continuous bead of urethane. Direct the flow of urethane down into gap as shown in Fig. 2D-105. The material should fill the gap between the glass edge and the sheet metal. If necessary, use a flat-bladed instrument to paddle material into position. Be sure that adhesive contacts the entire edge of the glass, and extends to fill the gap between the glass and primed sheet metal or solidified urethane base from the original installation.
8. Spray a mist of water onto the urethane. This adhesive is moisture curing. Water will assist in the

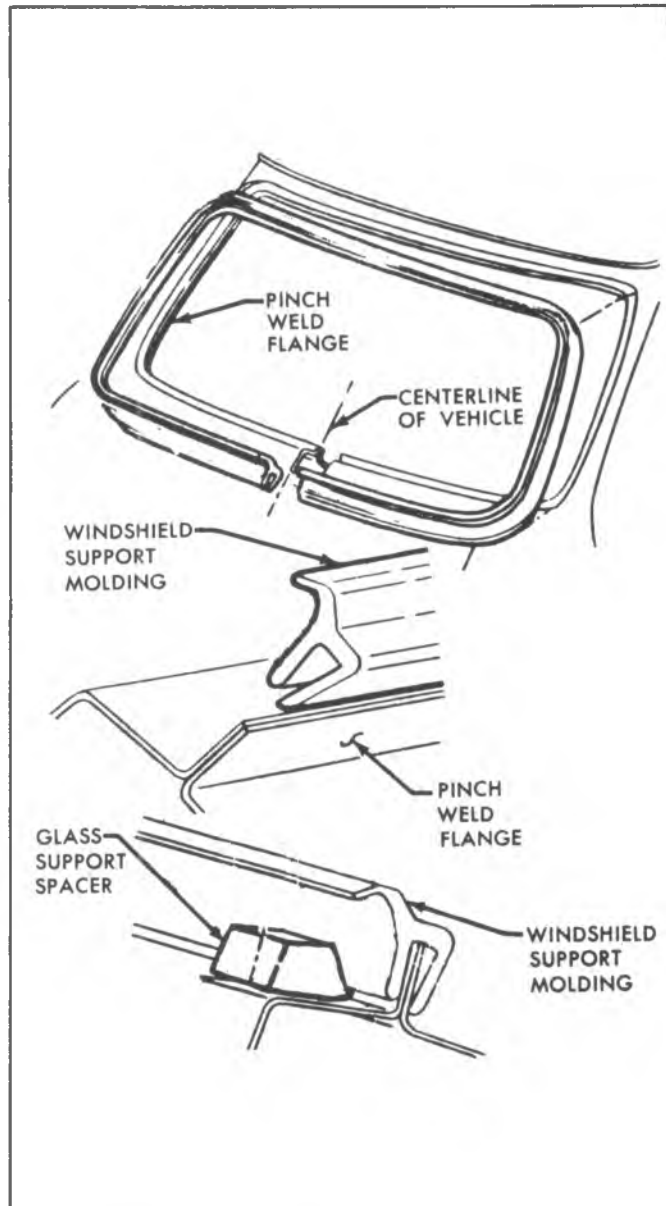

Fig. 2D-103 Support Molding Installation

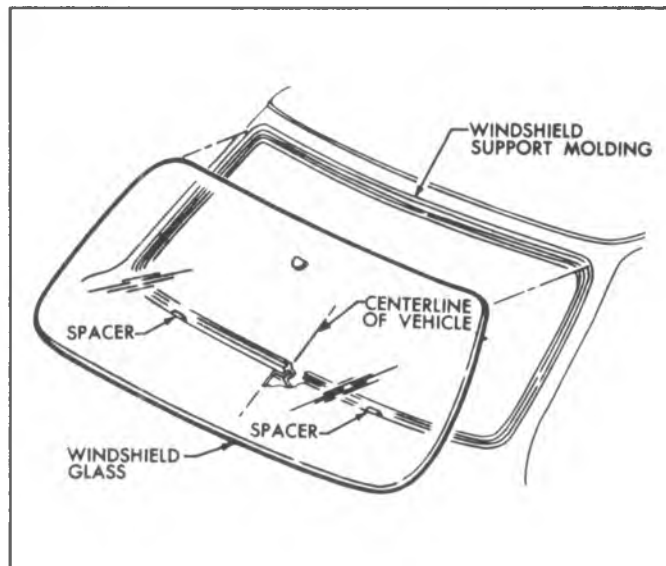

Fig. 2D-104 Windshield Installation

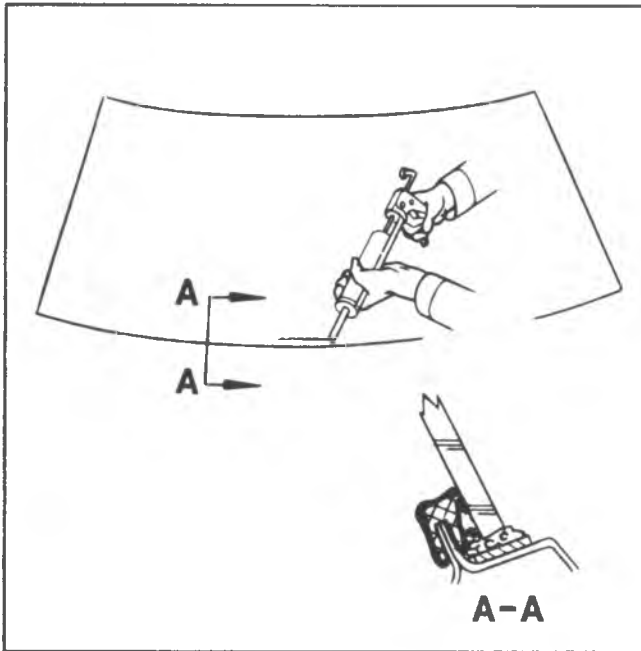

Fig. 2D-105 Adhesive Material Application

curing process. Dry the area where the reveal molding will contact the glass and the body.

9. To install the outside reveal moldings. If new moldings are installed, remove the protective tape covering the butyl adhesive on the underside of the molding. If the original moldings are reusable, remove any excessive butyl or urethane. Push molding caps on to either end of one of the reveal moldings. Press the molding retention lip into the urethane adhesive against the edge of the windshield as shown in Fig. 2D-106 taking care to seat the molding in the corners. Be sure the lip fully contacts the adhesive all around and that the gap is entirely covered by the crown of the molding. Slide molding caps into position between moldings connecting them. Use tape to hold the molding down in the correct position against the body and glass until the adhesive cures.
10. Install wiper arms, and clean up surrounding areas as required.  
Vehicle should not be driven and remain at room temperature for **six hours** to allow proper cure of adhesive.
11. Water leak test the vehicle. If a leak is found, refer to Windshield Waterleak Correction procedure.

**WINDSHIELD WATERLEAK CORRECTION**

With the urethane bonded glass on the G model, water leaks can be corrected without the removal of the reveal moldings or glass from inside the vehicle. Removal of the garnish and support molding will expose the urethane bond from the glass to the body. Refer to Figure 106.

It is not necessary to remove the plastic reveal molding to correct water leaks in most cases.

1. To locate the source of a water leak, remove the windshield garnish molding if so equipped, from the inside of the vehicle.
2. Remove the windshield support molding, Figure 10, from the inside of the vehicle without removing the windshield.
3. Locate the piston of the water leak by applying low air pressure to the urethane seal around inside of the windshield while water or a soapy solution is sprayed

to the exterior windshield reveal molding area. If bubbles appear at the windshield area, a water leak exists in the urethane seal. A minor leak can be repaired with the addition of urethane adhesive (Kit No. 9631000 or Essex SCD 435-20 or equivalent).

To apply sealer in the windshield reveal molding and urethane area, use a heat gun to warm the area slightly and then carefully move the plastic reveal molding with a flat bladed tool sufficiently to allow the sealer to be inserted in the leak area.

4. Water may be leaking through a pinch weld seam in the top of the windshield opening because of sealer voids in the front roof drip rail and not the urethane bond.

To determine if a water leak exists in the roof drip rail sealer, remove one sun visor assembly. Apply low pressure air through the sun visor assembly opening and at the same time, apply water or a soapy solution to the exterior roof drip rail area. If a leak exists in this area, bubbles should appear in the water being applied to the outside roof drip rail area. In these instances the roof drip rail should initially be prepped with a cleaner (such as is available from Kent Part No. 32180 or Dominion Sure Seal Part No. B.S.S.). Then joint and seam sealer, which can later be painted (such as is available from Kent No. 32130 or Dominion Sure Seal Part No. C.S.C.), should be applied.

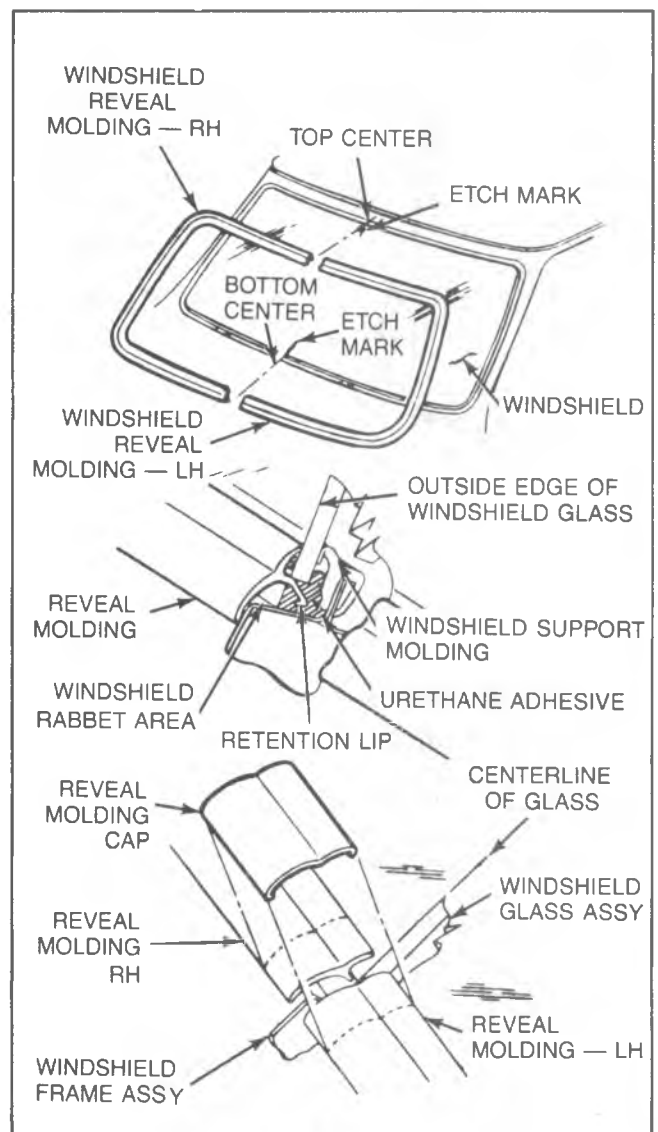

Fig. 2D-106 Reveal Molding Installation

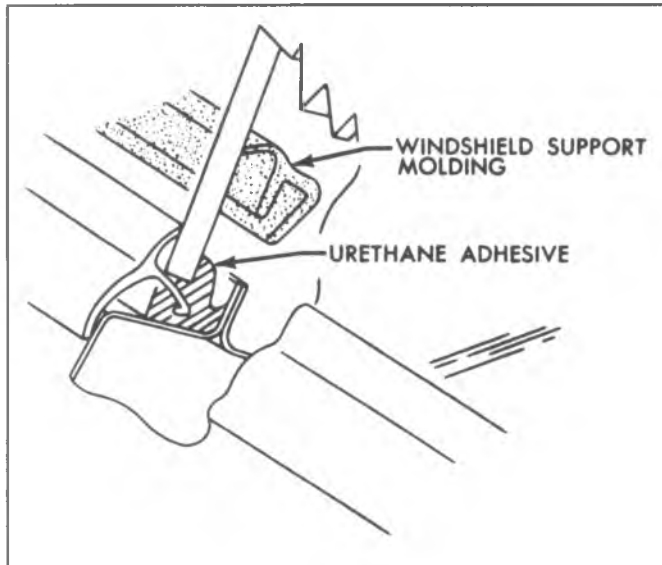

Fig. 2D-107--Support Molding and Adhesive

5. Using warm or hot water, leak test to assure that the leak has been corrected.



Fig. 2D-109--Swingout Window

## DOOR ADJUSTMENTS

Doors can be adjusted for alignment of clearance in the cab door opening, and for proper latching. Door alignment adjustments are made at the striker bolt, and at door hinges. The door, when properly located in door opening, will have equal clearance around its perimeter. The door should be adjusted in the opening so the edge of the door across the top and also at the lock side is parallel with the body opening as nearly as possible.

### Hinge Adjustment

Door hinge bolt holes are oversized to make adjustment possible. Alignment adjustments can be made by loosening the proper hinge bolts, aligning door to proper position, and

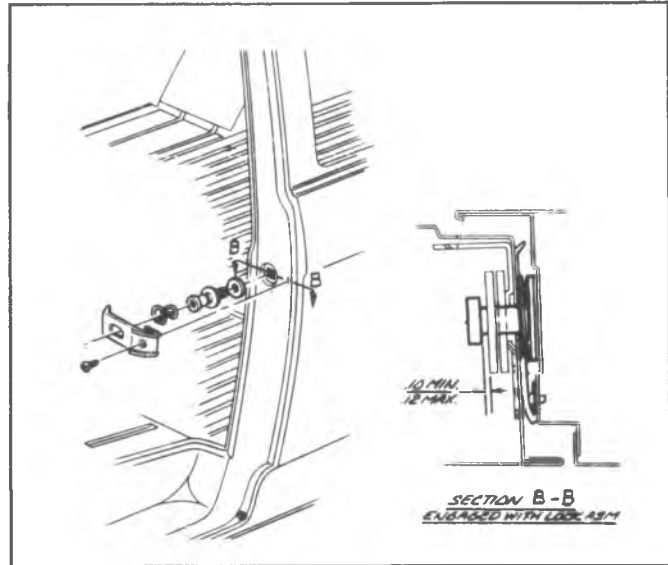

Fig. 2D-108--Body Window Glass

6. Install the support molding immediately.

## SWINGOUT WINDOW

### Replacement

1. Swing out the window. See figure 2D-109.
2. Remove screws retaining latch to body.
3. Remove window by swinging glass out, separating assembly at hinge.
4. Remove latch from glass by twisting and pulling out.
5. Reverse removal procedure to install swingout window.

## LATCH SWINGOUT WINDOW

### Replacement

1. Swing out the window.
2. Remove latch to body attaching screws.
3. Twist and pull latch to remove from glass.
4. Reverse above steps for installation.

## FRONT DOOR

tightening bolts securely. See figure 2D-110, for typical adjustments.

### Striker Bolt Adjustment

With the use of J-23457, shown in figure 2D-111, the striker bolt can be adjusted in any of three ways. See figure 2D-112.

1. **Up and down**-To adjust striker up or down, loosen bolt, adjust to center of lock entry, and tighten bolt securely. This adjustment is important to assure that the right proportion of door's weight will rest on striker bolt when door is closed. If bolt is positioned too high on pillar, rapid wear will occur to the lock cam; if too low, an extra load will be placed on door hinges as well as pulling door downward and out of alignment.

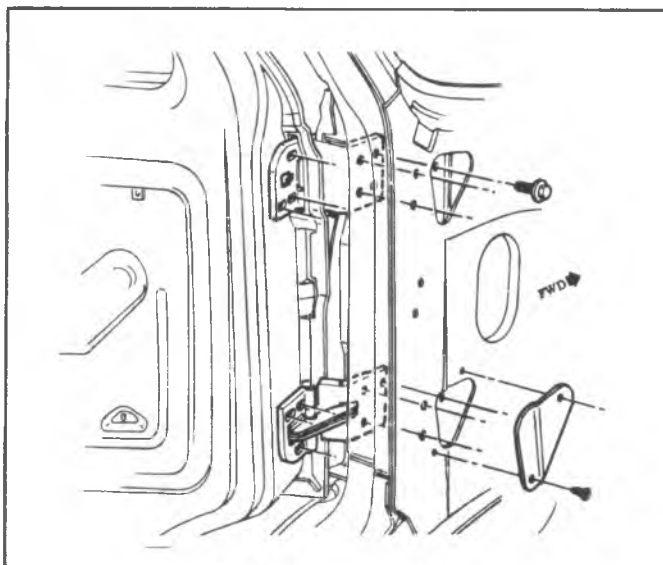

Fig. 2D-110--Door Hinge

2. **In and Out**-To adjust striker in and out, loosen bolt, adjust horizontally to match the door surface to the body surface, and tighten bolt securely.
3. **Forward and Rearward**-To make this adjustment, loosen striker bolt, shim to desired position, and tighten bolt securely.

**DOOR HINGE**

**Remove**

1. Remove hinge access hole cover from door hinge pillar.
2. If removing one hinge, support door in such a manner that weight is taken off other hinge, and that the door will not move.
3. Remove hinge screws from both body and from door and remove hinge. See figure 2D-110.

**Installation**

1. Install hinge to door and body. Snug bolts.
2. Remove door supports.

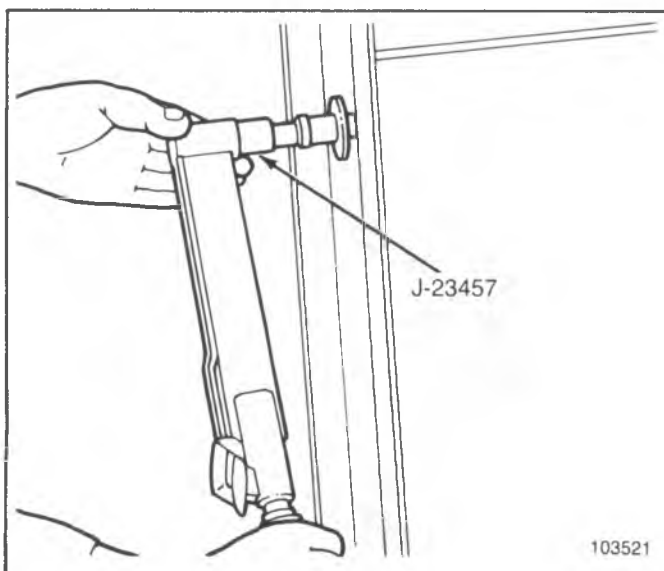

Fig. 2D-111--Loosening Striker Bolt

3. Adjust door as outlined under "Door Adjustment".
4. Torque bolts to specifications.
5. Install hinge access hole covers.

**DOOR WEATHERSTRIP**

Success of weatherstrip replacement depends entirely upon the quality of the cement used and the care with which it is applied. All rust, road dirt and grease or oil must be completely removed as should all old cement and bits of old weatherstrip. After removing all foreign material from door opening surface, wipe down with prepsol or its equivalent. Use only a good quality cement which is made specially for weatherstrip installation, following the manufacturer's directions. Proceed as follows:

1. Open door and block open.
2. Remove side door weatherstrip.
3. Remove used adhesive from door with adhesive or cement remover, and remove all plastic nails.
4. Apply adhesive to door.
5. Position weatherstrip by locating part number at top of vent window, making sure that plastic nails align with holes in door.
6. Install weatherstrip by pressing each nail into the door.

**TRIM PANEL, ARM REST AND HANDLES**

**Removal**

1. Remove screws retaining arm rest to trim panel.
2. Remove door and window handles with Tool J-9886-01 and pull from shaft.
3. Remove trim panel screws and remove panel. If plastic water shield seal is damaged, replace seal.

**Installation**

1. Install trim panel.
2. Install arm rest. Install door and window handle washers and handles.

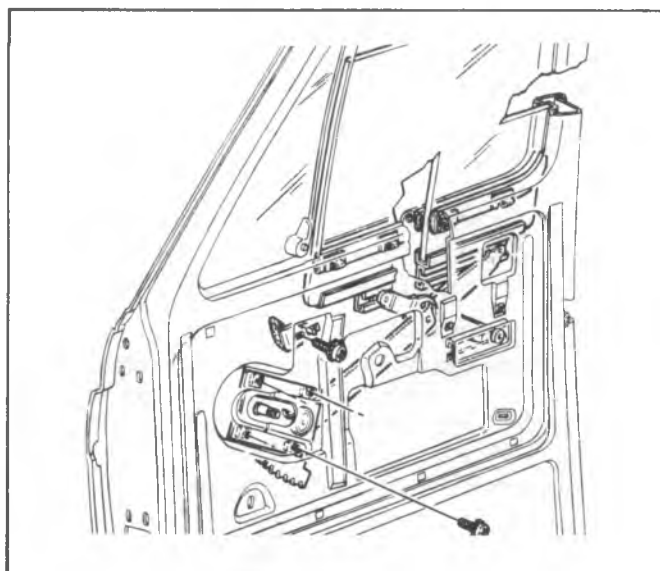

Fig. 2D-112--Typical Striker Bolt Adjustment



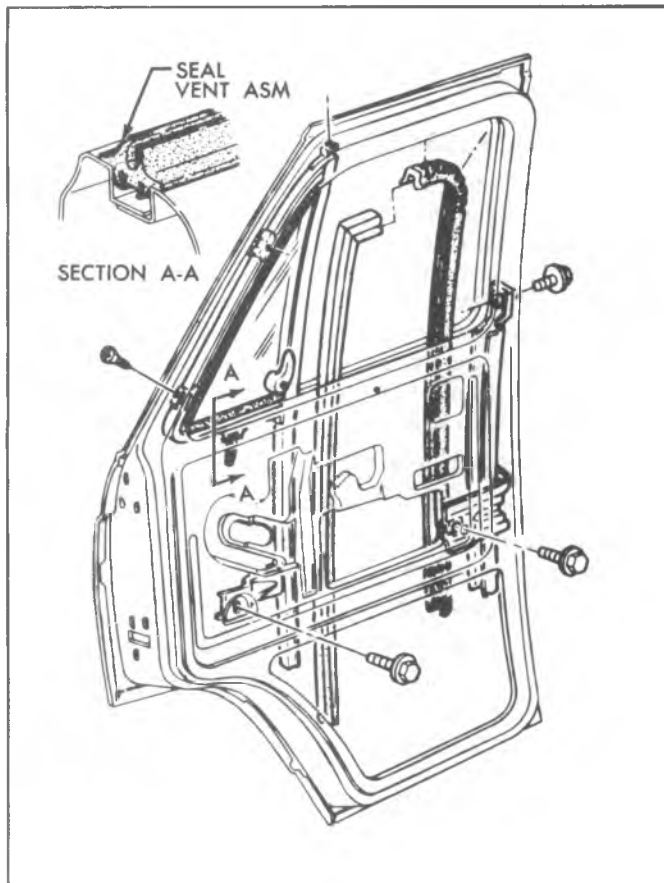

Fig. 2D-113--Channel, Run and Ventilator Assembly

## DOOR VENTILATOR ASSEMBLY

### Removal

The channel between the door window glass and door vent is removed as part of the vent assembly.

1. Regulate the door window glass to the full down position.
2. Remove door and window handles with Tool J-9886-01.
3. Remove trim panel and water shields.
4. Remove rear window run channel screws.
5. Slide door window glass rearward away from ventilator.
6. Remove three screws at the upper front of the door and lower forward channel screw, as shown in figure 2D-113.
7. Pull the upper portion of the ventilator rearward.
8. Turn the vent assembly 90° and carefully remove by guiding up and out, as shown in figure 2D-114.

### Ventilator Glass Replacement

1. Using an oil can or similar means, squirt prepsol on the glass filler all around the glass channel or frame to soften the old seal. When the seal has softened, remove the glass from the channel.
2. Thoroughly clean the inside of the glass channel with sandpaper, removing all rust, etc.
3. Using new glass channel filler, cut the piece to be installed two inches longer than necessary for the channel. Place this piece of filler (soapstoned side of

filler away from glass) evenly over the edge of the glass which will fit in the channel. The extra filler extending beyond the rear edge of the glass should be pinched together to hold it in place during glass installation.

One side of this filler (the outside of the roll) is soapstoned. This is the side which goes into the metal channel.

4. Brush the inside of the metal glass channel freely with ordinary engine oil. This will enable the glass and filler to slide freely into the channel.

Glass should be installed so that rear edge is parallel to the division post. Allow full cure before water testing.

### Installation

Replace the door window glass and regulate to the full down position before installing the door ventilator assembly.

1. Lower the ventilator assembly into the door frame. Center into position.
2. Make certain the rubber lip is positioned before tightening screws.
3. Slide door glass forward engaging glass in vent channel.
4. Reinstall all screws and tighten.
5. Install and tighten the three screws at the upper front of the door.

### Adjustment

1. Adjust the ventilator adjusting nut by turning clockwise to increase operating tension, as shown in figure 2D-115.
2. After making adjustment bend tabs over the hex nut.
3. Install trim panel.
4. Install door and window regulator handles.

## DOOR WINDOW ASSEMBLY

### Replacement

1. Completely lower glass to bottom of door.
2. Remove door arm rest, trim pad and water shields.
3. Mask or cover upper portion of door window frame.

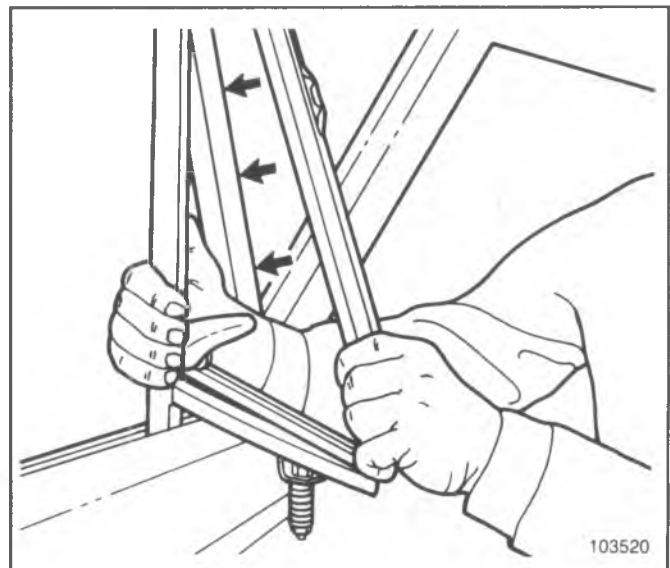

Fig. 2D-114--Removing Ventilator



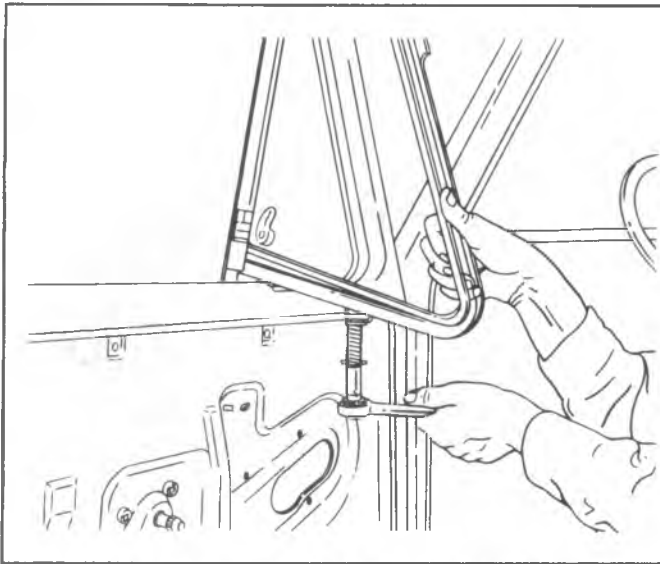

Fig. 2D-115--Adjusting Ventilator Tension

4. Remove ventilator assembly as previously outlined.
5. Raise window until regulator arms are level with access hole in door.
6. Slide glass forward until front roller is in line with notch in sash channel. Disengage roller from channel. See figure 2D-116.
7. Push window forward and tilt front portion of window up until rear roller is disengaged.
8. Put window assembly in normal position (level) and raise straight up and out.
9. Reverse above procedure for installation.

### DOOR WINDOW ADJUSTMENT

To perform the adjustments listed, the door trim panels must be removed.

#### Glass Height (Fig. 2D-116)

Loosen the bolt and adjust the stop assembly located above the regulator sprocket so that the glass height in the lowered position is flush with the top of the sill, then tighten stop assembly bolt.

#### Regulator Raising and Lowering Effort (Fig. 2D-109)

The lower bolt on the run channel assembly provides fore and aft movement to ease regulator effort.

### WINDOW REGULATOR - MANUAL

#### Replacement

1. Wind window all the way up.
2. Remove inside door handles with Tool J-7797.
3. Remove door trim pad.
4. Remove screws securing regulator to inner panel.
5. Push regulator out of door opening while holding rear of assembly, then slide assembly to the notches in the carrier channel and out through the door access hole.
6. Install regulator in reverse order of removal, lubricate regulator gears with lubriplate or equivalent.

### WINDOW REGULATOR - POWER

In the case that window will not operate, check electrical connections first. Figure 2D-118 illustrates location of junctions, switch, relay and circuit breaker.

#### Replacement

**CAUTION:** Electrical connectors must be removed from window lift motor before performing any operation on the regulator, or personal injury could occur.

1. Disconnect battery ground cable.
2. Remove door trim panel.
3. Disconnect harness from regulator.
4. Remove screws securing regulator to inner panel.
5. Push regulator out of door opening while holding rear of assembly, then slide assembly to the notches in the carrier channel and out through the door access hole.

**CAUTION:** Step 6 must be performed when regulator is removed from door. The regulator lift arms are under tension from the counterbalance spring and can cause serious injury if the motor is removed without locking the sector gear in position.

6. Drill a hole through the regulator sector gear and back plate. DO NOT drill hole closer than 1/2" (12.7mm) to edge of sector gear or back plate. Install a pan head sheet metal tapping screw (No. 10 - 12 x 3/4) in drilled hole to lock sector gear in position.
7. Remove motor to regulator attaching screws.
8. Remove motor from regulator.
9. Prior to installation, lubricate the motor drive gear and regulator sector teeth.

The lubrication used must be cold weather approved to a minimum of minus 20° fahrenheit (-29°C).

10. Install regulator motor to regulator. Make sure the motor pinion gear teeth mesh properly with the sector gear teeth before installing the three motor attaching screws.

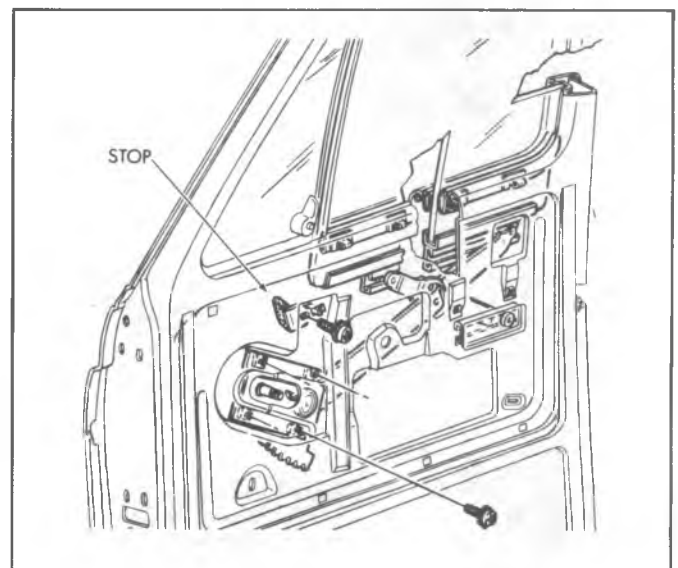

Fig. 2D-116--Window and Regulator

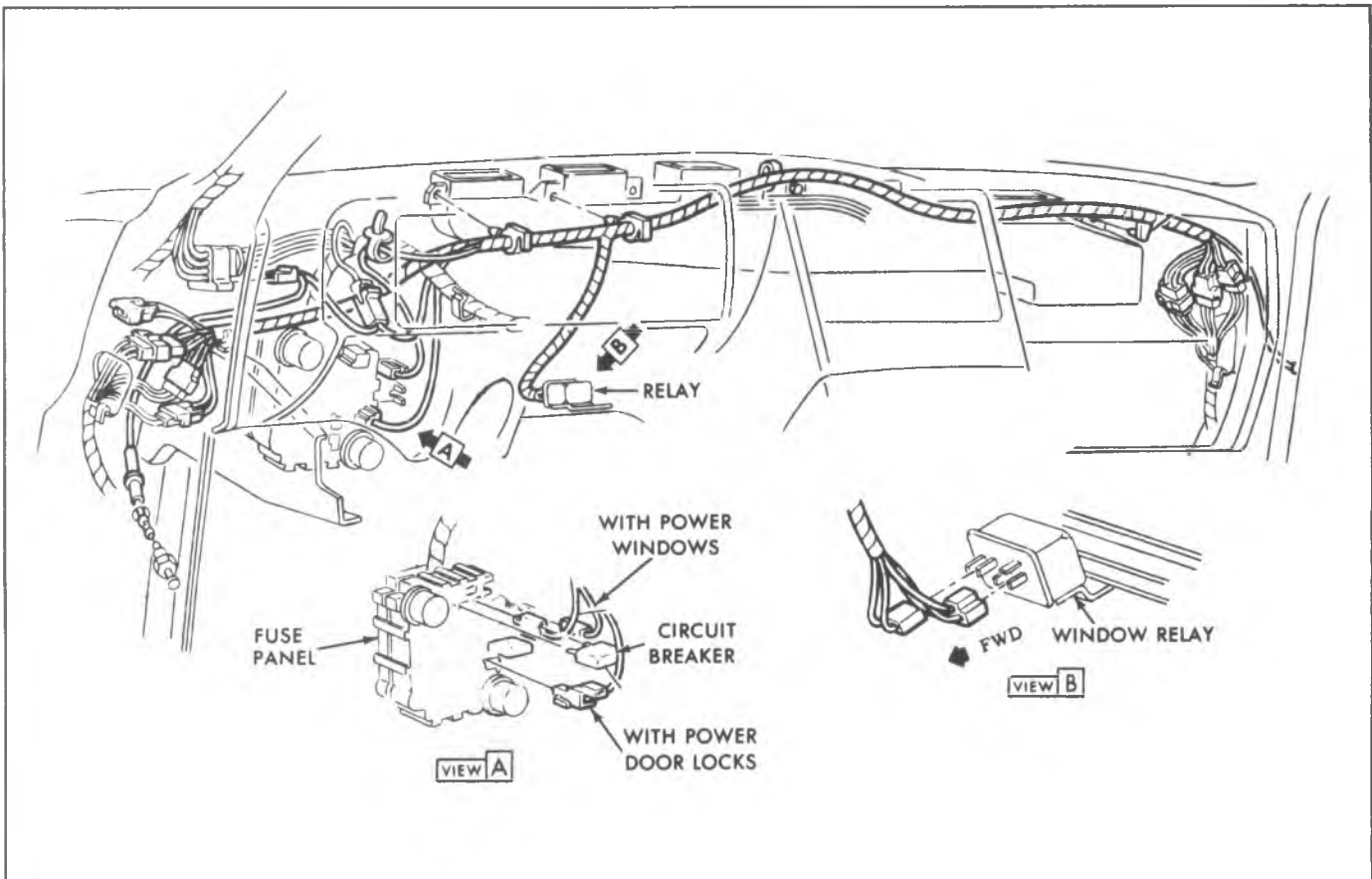

Fig. 2D-117--Power Window and Power Door Lock Wiring

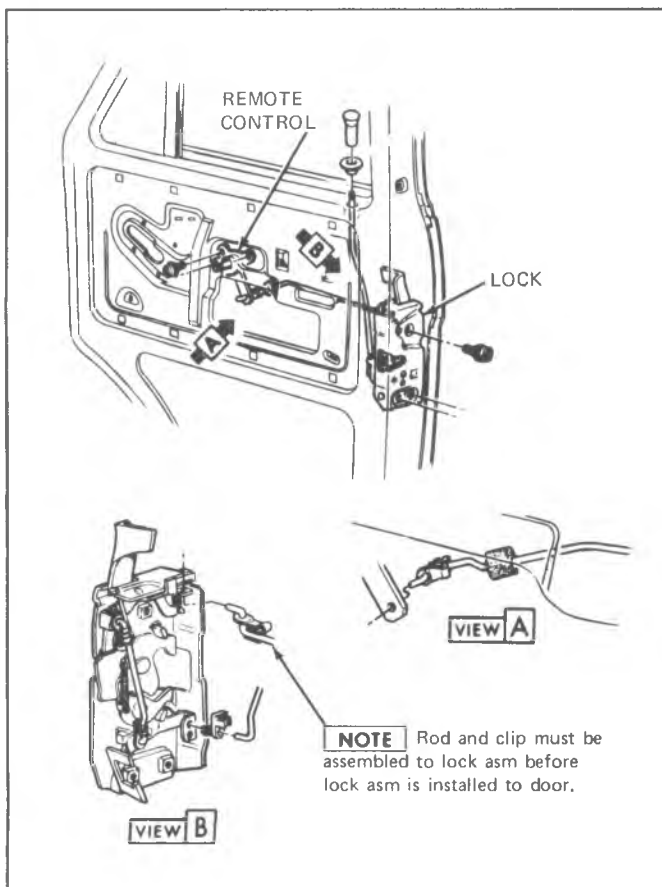

Fig. 2D-118--Lock and Remote Control Assembly

11. Remove screw locking sector gear in a fixed position.
12. Install regulator in reverse order of removal, lubricate regulator gears and rollers with lubriplate or equivalent.

### DOOR LOCK-FIGURE 2D-118

#### Removal

1. Raise window.
2. Remove inside handles with Tool J-9886-01.
3. Remove trim panel.
4. Remove door lock knob.
5. From outside the door remove screws retaining lock to door edge and lower the lock assembly.
6. Remove screws retaining remote control.
7. Remove screws securing glass run guide channel.
8. Remove lock, push button rod and remote control rod as an assembly.

#### Installation

1. Transfer remote rod with clip to new lock.
2. Connect remote door handle rod to lock after lock is positioned.
3. Secure lock screws and glass run guide channel.
4. Secure remote handle.
5. Check all controls for proper operation before reinstalling trim and handles.
6. Install door lock knob.

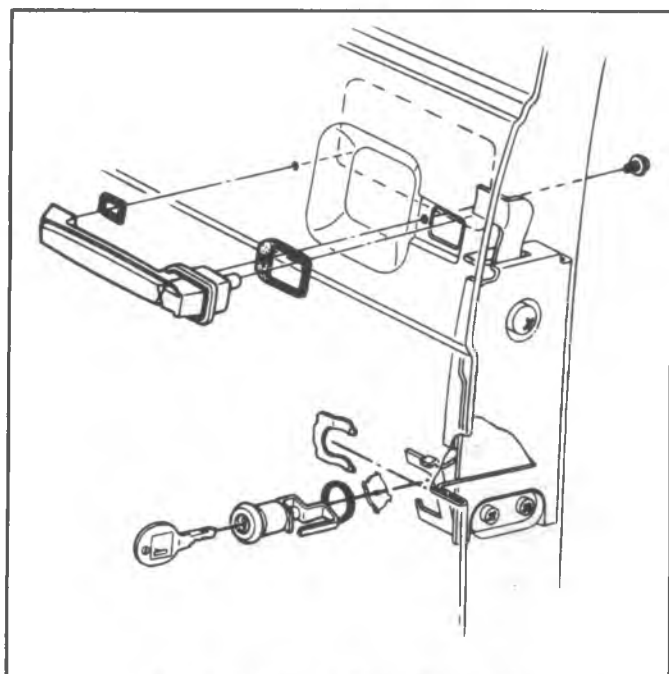

Fig. 2D-119--Lock Cylinder Assembly

## REMOTE CONTROL AND CONNECTING

### ROD--Fig. 2D-118

#### Replacement

1. Raise door window and remove door trim pad.

2. Remove bolts securing remote control to door inner panel.
3. Pivot remote inboard slightly, to disengage connecting rod, and remove remote control from door.  
Connecting rod can be removed at this point by disconnecting spring clip from lock.
4. To install, reverse removal procedure.

## POWER DOOR LOCKS

The power door lock system incorporates a motor actuator in each door which actuates the lock through linkage (fig. 2D-120). See Figure 2D-117 for switches, relay and wire routing.

#### Replacement

1. Disconnect battery ground cable.
2. Remove door trim panel to gain access to power door lock motor.
3. Disconnect electrical connector from motor.
4. Remove screws attaching motor to door inner panel.
5. Remove door lock lever from rubber mount at top of motor actuator and remove motor through access hole.
6. To install, reverse steps 1 through 5 above.

## LOCK CYLINDER ASSEMBLY--FIG. 2D-119

#### Replacement

1. Raise door window and remove door trim pad.
2. With a screwdriver, or other suitable tool, slide lock cylinder retaining clip (on door outer panel) out of engagement and remove lock cylinder.
3. To install, reverse removal procedure.

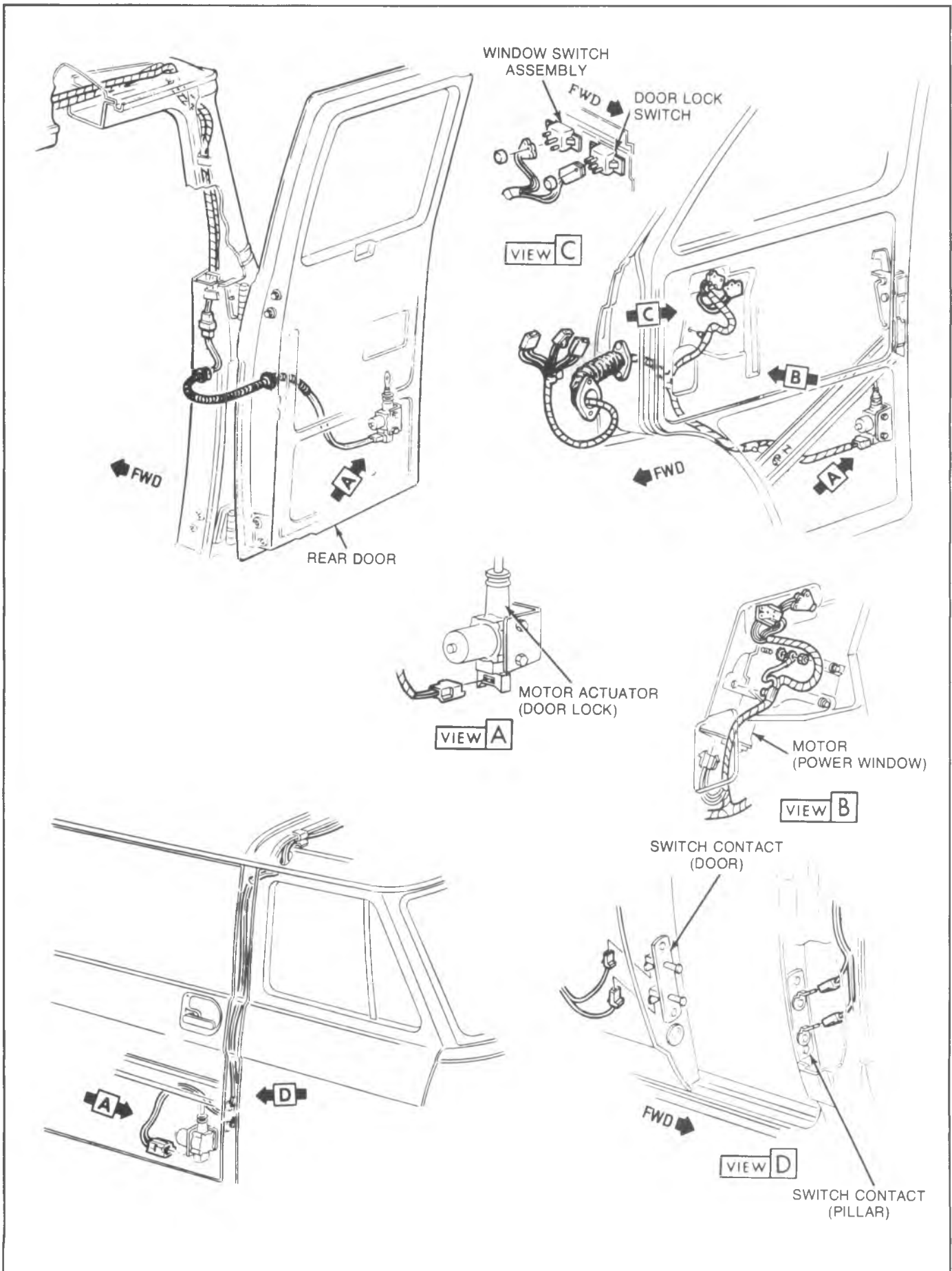

Fig. 2D-120--Power Door Lock Actuators, Power Window Motor, Wiring and Switches

## SLIDING SIDE DOOR

### DESCRIPTION

The weight of the sliding side door is supported by the upper rear hinge-and-roller assembly, and by the lower front catch-and-roller assembly. The front and rear latches retain the door in the locked position, while the rear wedge assembly restricts door vibration on rough road surfaces.

### ADJUSTMENTS

**NOTICE:** See NOTICE on page 1 of this section regarding all sliding door fasteners and adjustments found below.

The side door can be adjusted for alignment and/or clearance in the body opening and for proper latching. When properly positioned in the body opening, the door should have equal clearances around its perimeter. Adjustments for door positioning and proper latching can be made at the locations shown in figure 2D-121.

#### Up and Down

Up and down adjustments are provided by means of slotted holes located at the upper front roller, view B of figure 2D-121; at the lower front catch-and-roller, view D; and at the upper rear hinge-and-roller assembly, view A. To reposition the door up or down:

1. Partially open door and loosen front latch striker on pillar.
2. Remove upper rear hinge cover, shown in figure 2D-122.
3. Loosen upper rear hinge-to-door bolts.
4. Loosen rear lock striker and door wedge assembly.
5. Align rear edge of door up or down, then tighten upper rear hinge-to-door bolts to specifications.
6. Loosen upper front roller bracket-to-door bolts.
7. Partially close door and align front edge of door up or down by loosening front lower hinge-to-door bolts. When door is correctly positioned, tighten bolts to specifications.
8. Position upper front roller in center of track, then tighten roller bracket to door.
9. Adjust front and rear strikers and rear wedge assembly as outlined in their respective procedures later in this section.

#### In and Out

Front in and out adjustments are provided by means of an adjustable lower roller mounting bracket, view D of figure 2D-121, and by a slotted upper bracket, view B of figure 2D-121. Rear in and out adjustment is provided by adjusting the rear latch striker, view E of figure 2D-121. To position the door in or out:

1. Loosen front latch striker.
2. Loosen upper front roller from its bracket.
3. Loosen lower front roller bracket-to-arm bolts.
4. Adjust front of door in or out, then tighten bolts to specifications.

5. Adjust door hold open catch bracket, rear wedge assembly, rear latch striker, upper front roller and front latch striker as outlined later in "Adjustments".

#### Fore and Aft

Fore and aft adjustment is provided at the upper rear hinge striker by means of a slotted bracket mounted to the body, view A of figure 2D-121.

1. Partially open door and remove front latch striker and rear lock striker.
2. Loosen rear wedge assembly.
3. Remove upper rear track cover.
4. Loosen upper rear hinge striker.
5. Move door assembly forward or rearward, then tighten striker bolts to specifications.
6. Reinstall upper rear track cover.
7. Reinstall front and rear latch strikers.
8. Adjust latch strikers and rear wedge assembly as outlined below.

#### Latch Striker Adjustments

##### Front Striker

1. Loosen front latch striker screws, view C of figure 2D-121.
2. Visually align latch-to-striker relationship and adjust if necessary.
3. Slide door slowly toward striker. The guide on the door, just above the latch, must fit snugly within the rubber-lined opening on the striker assembly.
4. Assure that the latch engages fully into the striker. Add or delete shims behind the striker as necessary.
5. Tighten striker screws to specified torque.

##### Rear Striker

1. Loosen striker with J-23457.
2. Loosen rear wedge assembly.
3. Center the striker vertically to door striker opening.
4. Adjust the striker laterally to match outer panel to the body panel surfaces, view E of figure 2D-121.
5. Apply grease to the striker.
6. Gently push the door in until the rear lock contacts the striker enough to make an impression in the grease.
7. Open the door and measure the distance from the rear of the striker head to the impression. The distance should be between .20 inch (5mm) and .30 inch (8mm). Refer to view E of figure 2D-121.
8. Adjust position of striker by adding or deleting shims between the striker and the pillar.
9. Adjust rear wedge assembly as outlined later in this section, and torque all fasteners to specifications.

#### Upper Rear Hinge-To-Striker Adjustment

**NOTICE:** If door has been removed and is being reinstalled, adjust striker-to-lower hinge lever before closing door. Failure to do so may cause possible lever breakage.

The upper rear hinge must be positioned as shown in

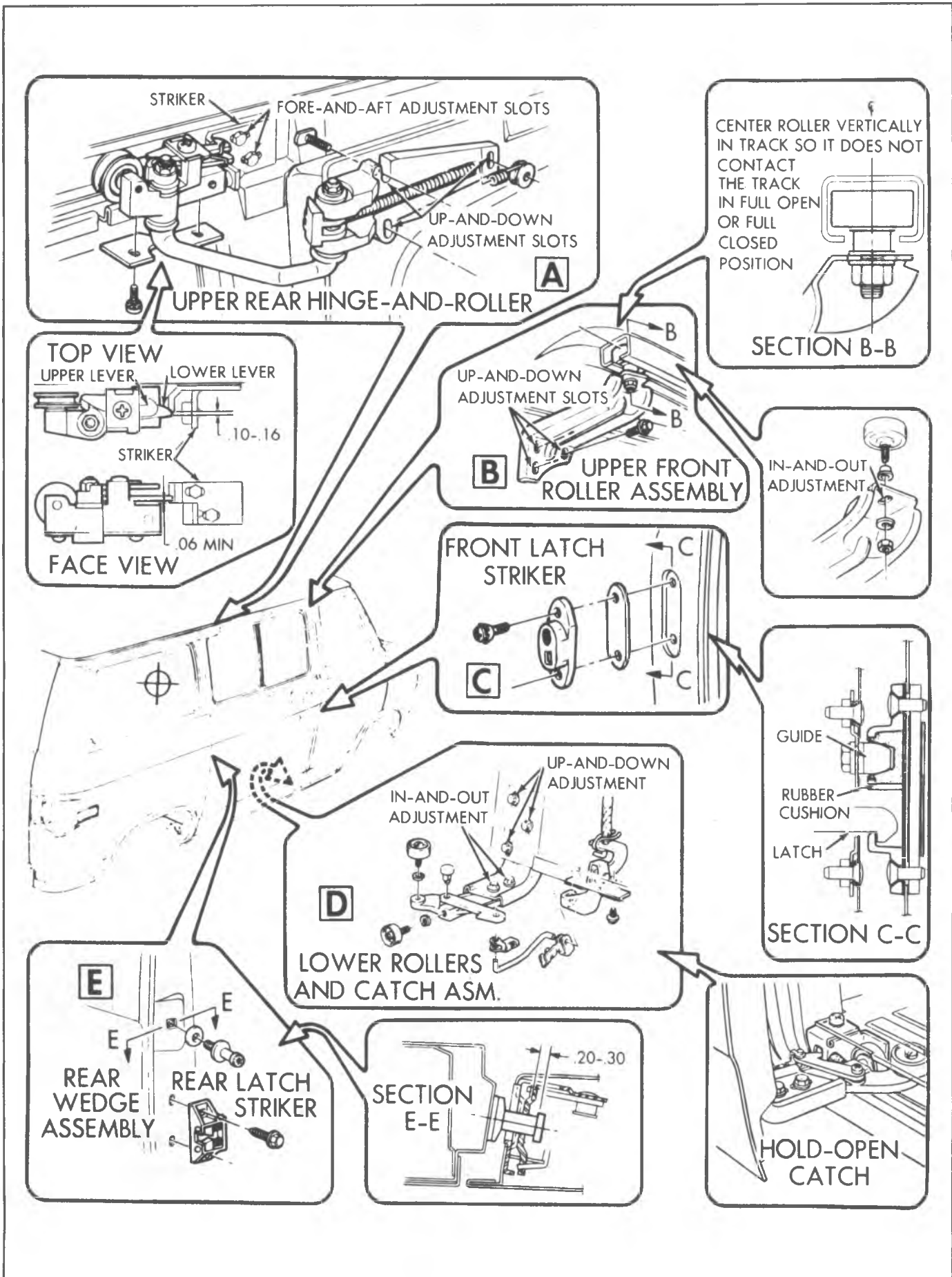

Fig. 2D-121—Sliding Side Door Adjustment Locations

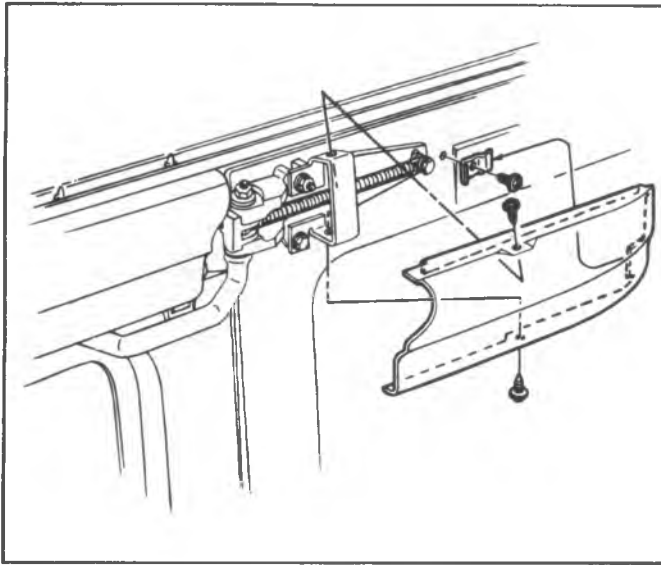

Fig. 2D-122--Hinge Cover

view A of figure 2D-121, in order to insure proper latching.

1. The hinge lower lever must contact the striker at least .06 inch above the lower edge of the striker tang.
2. The lower lever must extend at least .10 inch (2.5mm) outboard of the striker tang. Add or delete shims between the striker and the body as necessary.
3. If necessary to shim roller away from guide, shims are added between the nylon block and hinge and between roller and hinge. They must be installed in pairs. For example, if one shim is added behind the nylon block another must be added behind the roller.

### Door Hold-Open Catch Adjustment

This catch, mounted on the lower front roller bracket, holds the door in the full open position. See figure 2D-123. The catch engages a striker installed at the rear of the lower roller channel, view D of figure 2D-121.

1. Loosen the screws retaining the catch rod bracket to bottom of door.

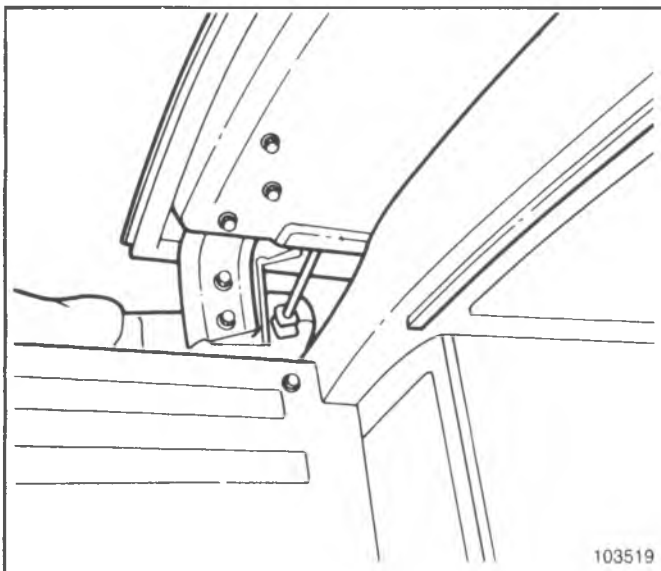

Fig. 2D-123--Hold-Open Catch

2. Adjust catch-to-striker engagement by sliding the bracket laterally. Catch should fully engage striker.

### Rear Wedge Assembly Adjustment

1. Loosen screws attaching rear wedge assembly to the body pillar, then close the door to the fully latched position.
2. Center the wedge assembly on the door wedge, as shown in figure 2D-124, and scribe a line around the wedge assembly.
3. Open the door, and move the wedge assembly 3/16 inch.

### FRONT LATCH ASSEMBLY

#### Removal

1. Remove trim panel, if so equipped.
2. Remove access cover.
3. Unscrew door lock knob from rod.
4. Disconnect the following rods from latch, shown in figure 2D-125.
  - a. Rear latch rods.
  - b. Lock cylinder rod.
  - c. Door lock rod.
5. Remove door handle.
6. Remove screws retaining latch assembly to door.
7. Slide latch rearward and lift front of latch. Disconnect rod leading to lower hinge door catch by pushing rod out of hole and rotating rod clear of latch.
8. Remove latch assembly from door.

#### Installation

1. Install latch assembly into door by working latch assembly behind the lower hinge door catch.
2. Connect lower hinge door catch, lock cylinder rod, door lock rod, and both rear latch rods.
3. Install latch assembly-to-door attaching screws. Torque to specifications.
4. Install door lock knob and door handle.
5. Install access cover and trim panel.

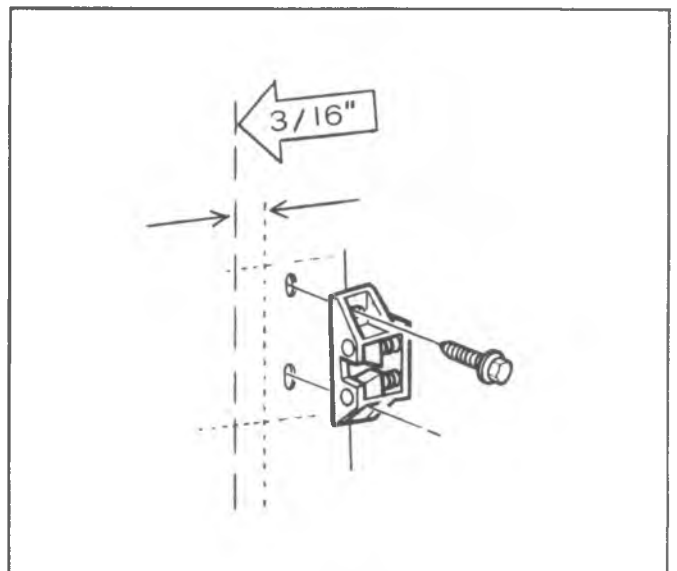

Fig. 2D-124--Adjusting the Rear Wedge Assembly



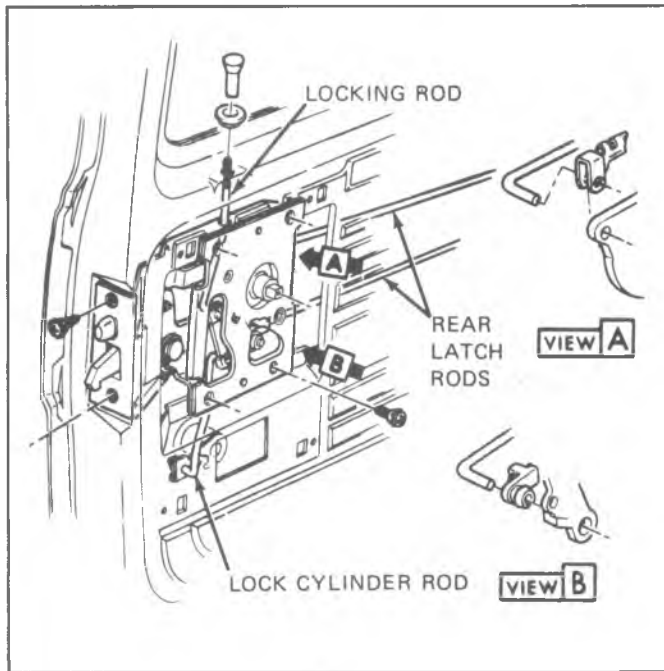

Fig. 2D-125--Sliding Door Front Latch

- Adjust door front striker as outlined earlier under "Adjustments".

## REAR LATCH AND/OR LATCH ACTUATING RODS

### Removal

- Remove trim panel (if so equipped).
- Remove front latch assembly access cover.
- Disconnect rear latch rods from front latch assembly, shown in figure 2D-125.
- Remove rear latch attaching screws. See figure 2D-126.
- Slide rear latch toward front of door until rod clips become exposed. Disconnect rod clips and remove latch from door.

### Installation

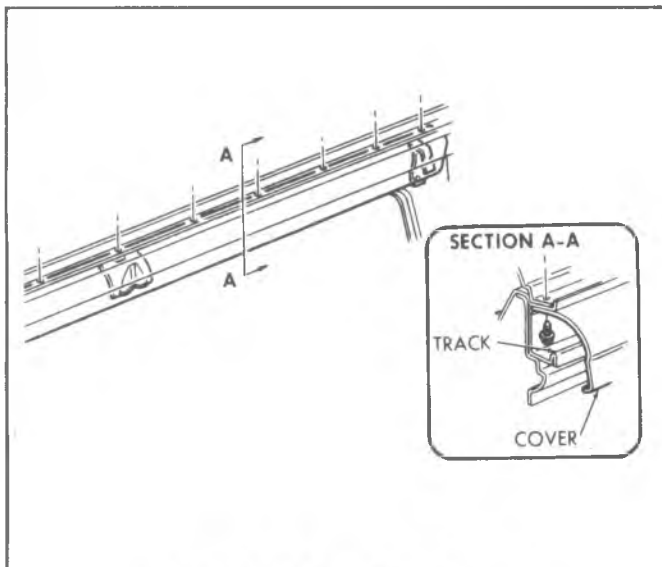

Fig. 2D-127--Rear Track Cover

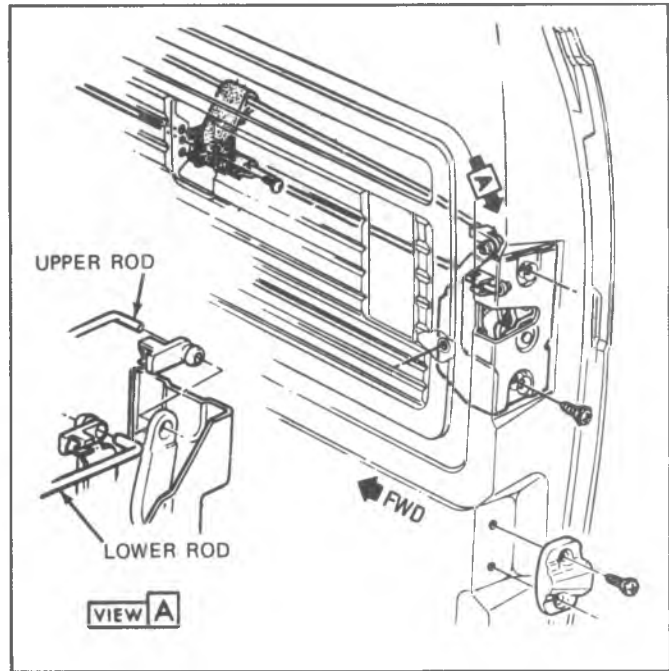

Fig. 2D-126--Sliding Door Rear Latch

- Connect rods to latch and install latch to door. Torque screws to specifications.
- Connect rods to front latch assembly.
- Install access covers and trim panels (if so equipped).
- Adjust rear latch striker as outlined earlier under "Adjustments".

## UPPER REAR HINGE

### Removal

- Remove the hinge cover and rear track cover. See figures 2D-122 and 2D-127.
- Open the door.
- Disengage spring from bolt, using a spring removal tool.
- Close the door.
- Remove the hinge assembly.

### Installation

When holding hinge assembly as in figure 2D-129, the lower latch must engage cam.

- Install hinge assembly to door. Torque bolts to specifications.
- Check and adjust latch to striker position as outlined under "Adjustments".
- Open the door and reconnect the hinge spring.
- Install the rear track cover and hinge cover.
- Check the operation of the door hinge.

## STRIKERS

The front and rear strikers are shown in figure 2D-121. The rear striker can be removed with J-23457 as in figure 2D-111, and the front striker can be removed by removing attaching screws. Refer to "Adjustments" when reinstalling.



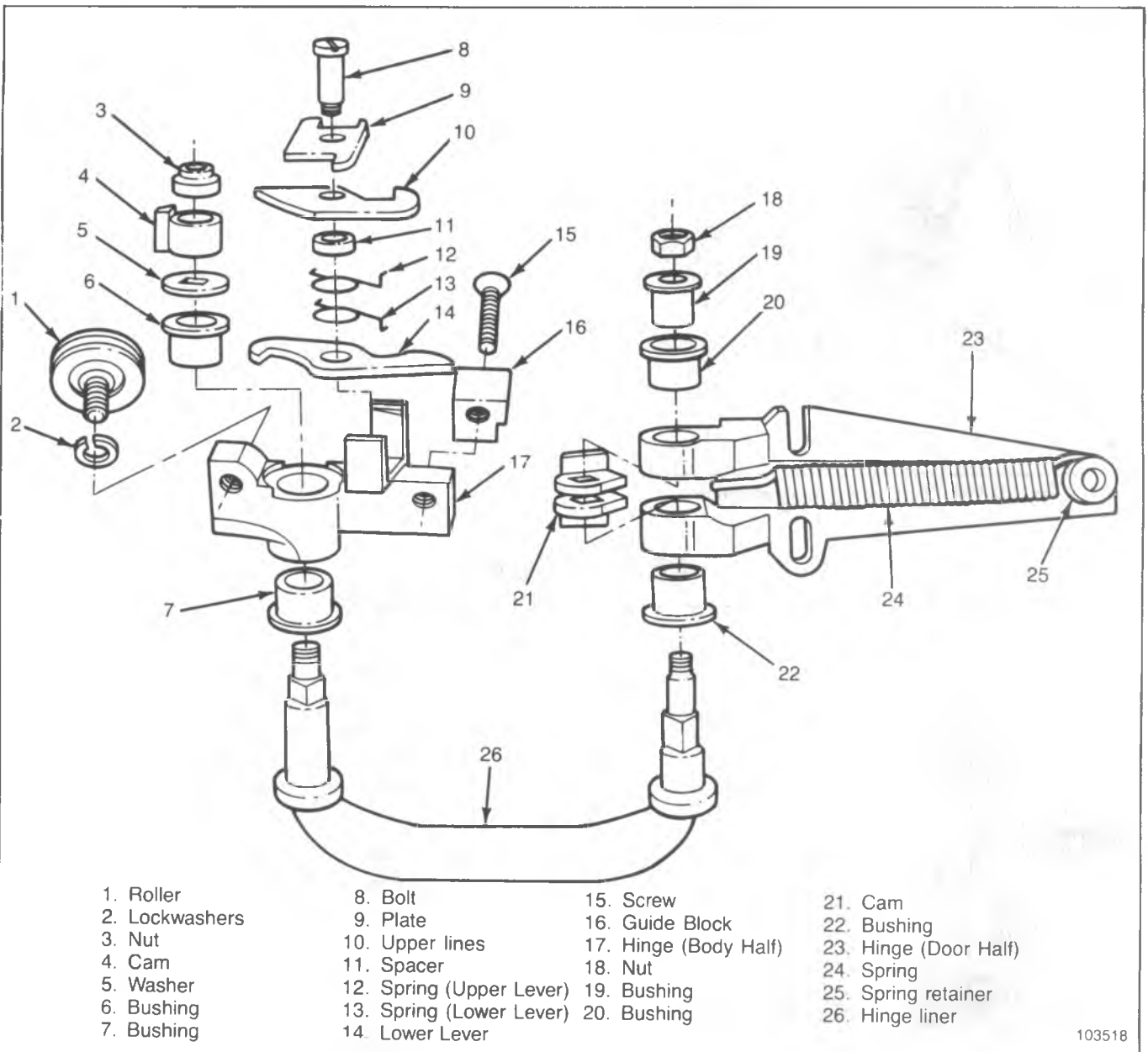

103518

Fig. 2D-128--Upper Rear Hinge Components

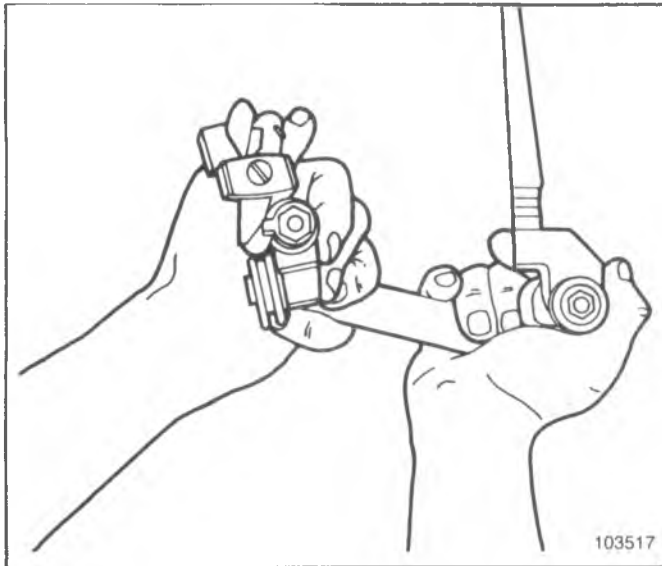

Fig. 2D-129--Checking Assembly of Hinge

## REAR DOORS

### REAR DOOR HINGE

#### Removal

1. Open door. Support door so that when hinge screws are removed door weight will be on support.
2. Remove hinge strap release pin.
3. Remove hinge-to-door bolts and remove door assembly.
4. Remove hinge-to-body bolts and hinge.

#### Installation

1. Install grommet into door hinge opening (if removed).
2. Install hinge into door. Snug bolts.
3. Install seal and retainer on body half of hinge (if removed).
4. Install hinge into body opening and install bolts.
5. Take care to compress seal between body and retainer and snug bolts.
6. Install hinge strap and its retaining pin.
7. Adjust door and torque hinge bolts to specification.

### REAR DOOR REMOTE CONTROL

#### Removal

1. Remove trim panel.
2. Disengage upper and lower latch rods from control by removing retaining clips. See figure 2D-131.
3. Remove remote control by removing its retaining screws.

#### Installation

1. Install remote control screws loosely.
2. Attach upper and lower control rods.
3. Rotate remote control lever clockwise, and hold in this position while torquing the screws to specifications.
4. Install the trim panel.

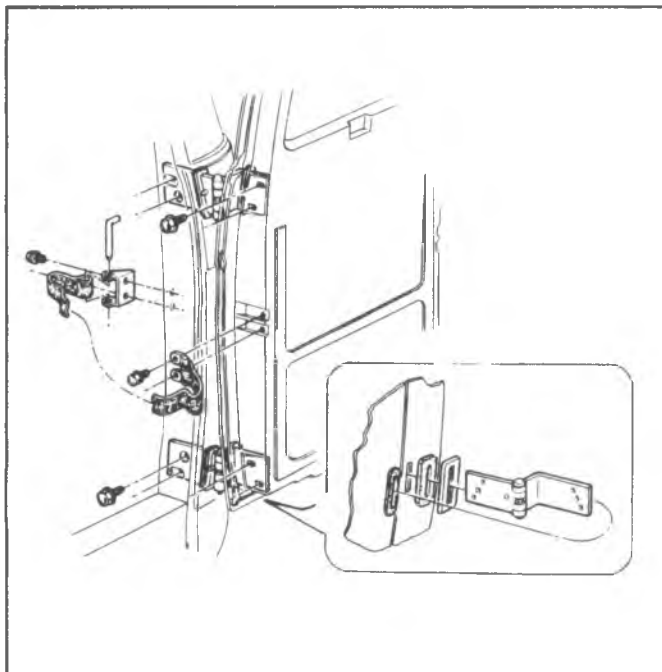

Fig. 2D-130--Rear Door Hinges and Strap

### REAR DOOR HINGE STRAP

#### Replacement

1. Remove strap release pin. See figure 2D-130.
2. Remove screws retaining strap to door.
3. Install strap to door. Torque retaining screws to specifications.

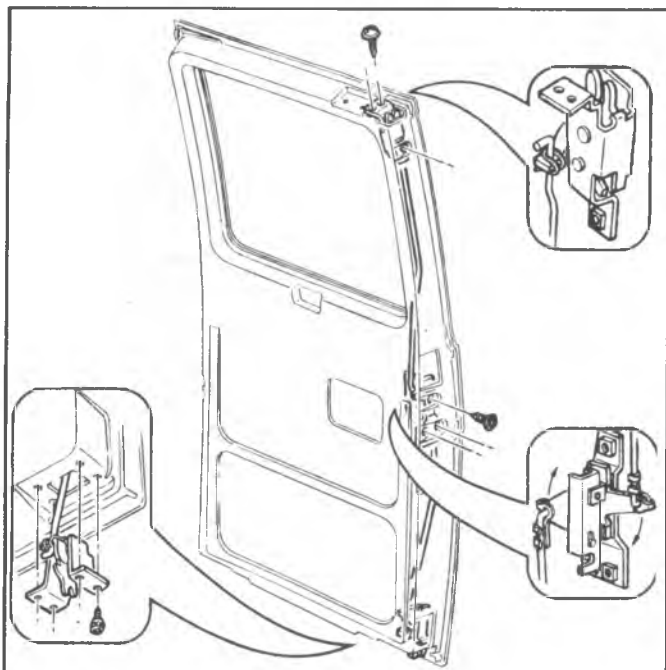

Fig. 2D-131--Remote Control and Latch

### REAR DOOR UPPER OR LOWER LATCHES AND / OR LATCH RODS

#### Removal

1. Remove trim panel.
2. Disengage rod from remote control assembly. See figure 2D-131.
3. Remove latch retaining screws and withdraw latch and control rod.
4. Remove spring clip retaining rod to latch.

#### Installation

1. Install latch rod to latch.  
When reinstalling the lower latch rod to control, the short straight section attaches to the latch.
2. Install latch and rod assembly into door and connect rod to remote control. Lube all moving parts.
3. Install latch retaining screws and torque to specifications.
4. Adjust latch to strikers.

### REAR DOOR OUTSIDE HANDLE

#### Removal

1. Remove trim panel.
2. Remove door handle retaining screws, handle and gaskets. See figure 2D-132.

#### Installation

1. Apply grease to remote control where handle plunger makes contact.
2. Install handle and gaskets. Torque screws to specifications.
3. Install trim panel.

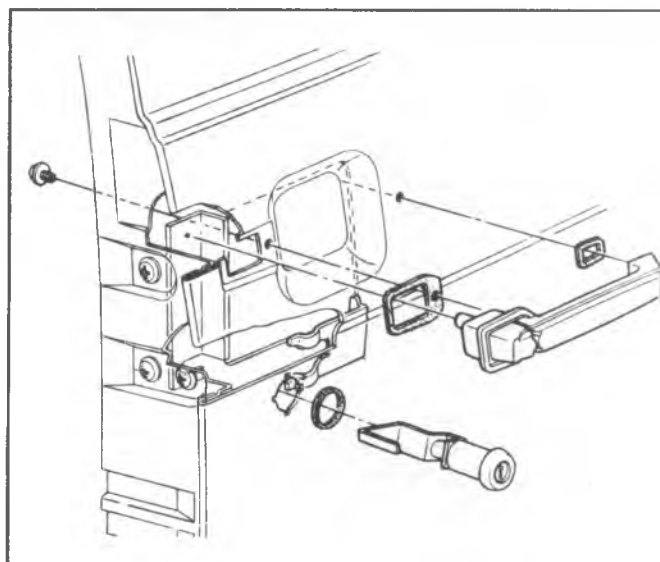

Fig. 2D-132--Outside Handle and Lock Cylinder

### REAR DOOR LOCK CYLINDER

#### Removal

1. Remove trim panel.
2. Remove remote control.
3. Remove lock cylinder retainer and lock cylinder.

#### Installation

1. Install lock cylinder and retainer.
2. Install remote control. Torque screws to specifications.
3. Install trim panel.

### REAR DOOR GLASS AND WEATHERSTRIP

Removal and installation procedures are the same as for the stationary body side windows. Refer to those procedures for rear door glass and weatherstrip replacement.

### REAR DOOR ADJUSTMENTS

Door adjustments are provided by slotted holes, at hinge attachment, in body and door.

1. Remove or loosen door strikers and wedges.
2. Loosen door hinge bolts and adjust door to provide equal clearances between body and door around perimeter of door.
3. Adjust door in and out so that door panel is flush with body.
4. Install door strikers and wedges and adjust as outlined under door striker adjustment.

## REAR DOOR STRIKER AND WEDGE ADJUSTMENT

**NOTICE:** See NOTICE on page 1 of this section regarding Rear Door Striker fasteners.

1. Adjust striker by adding or deleting shims as necessary to obtain dimension as shown in figure 2D-133. This dimension can be checked by applying grease to the latch and slowly closing door until striker fully engages latch. Then open door and measure from grease impression to bottom of latch slot. Torque to specifications.
2. Adjust door wedge by adding or deleting shims as necessary so that wedge contact ramp on body when door is closed. See figure 2D-133.

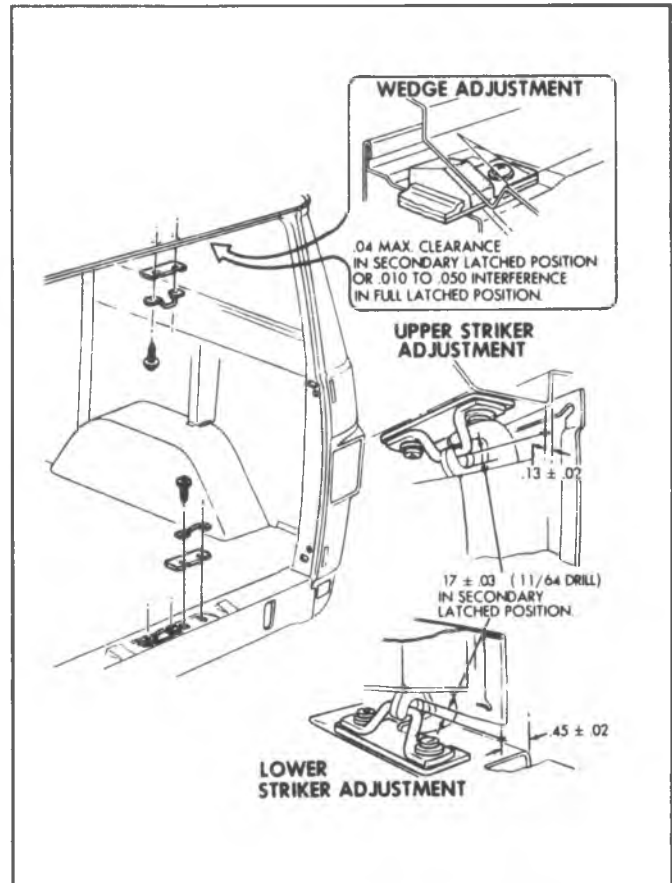

Fig. 2D-133--Rear Door Striker and Wedge Adjustment

## SEATS

### DRIVERS SEAT

#### Seat Adjuster

##### Replacement

1. Remove seat by removing nuts securing seat adjuster to seat riser.
2. Remove adjuster from seat. See figure 2D-134.
3. Install seat adjuster to seat. Torque bolts to specifications.
4. Install seat onto seat riser, and torque nuts to specifications.

#### SEAT RISER

##### Replacement

1. Remove seat and adjusters as an assembly by removing nuts securing seat to riser.
2. Remove nuts securing seat riser to floor.
3. Install seat riser to floor. Torque nuts to specifications.
4. Install seat and torque nuts to specifications.

#### PASSENGER SEAT--MOUNTING BRACKETS

##### Removal

1. Remove seat and brackets from seat riser. See figure 2D-135.

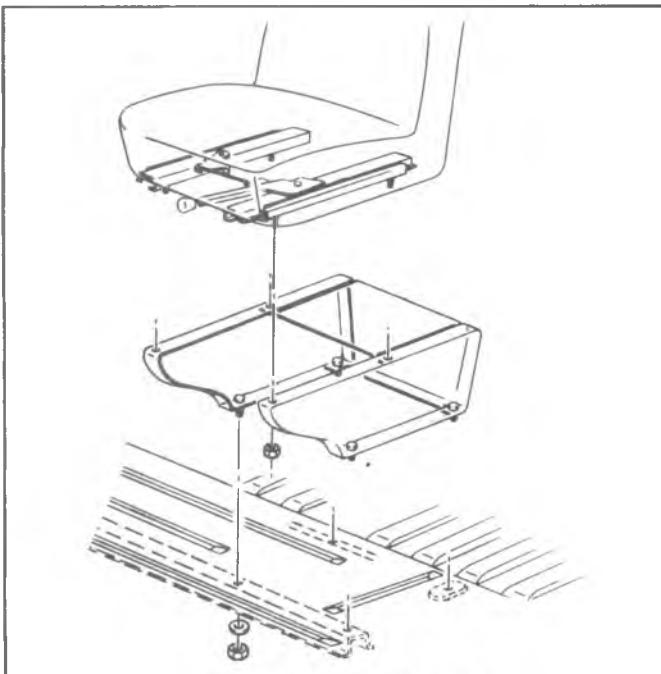

Fig. 2D-134--Driver's Seat

**NOTICE:** See NOTICE on page 1 of this section regarding fasteners used on seats and seat belts.

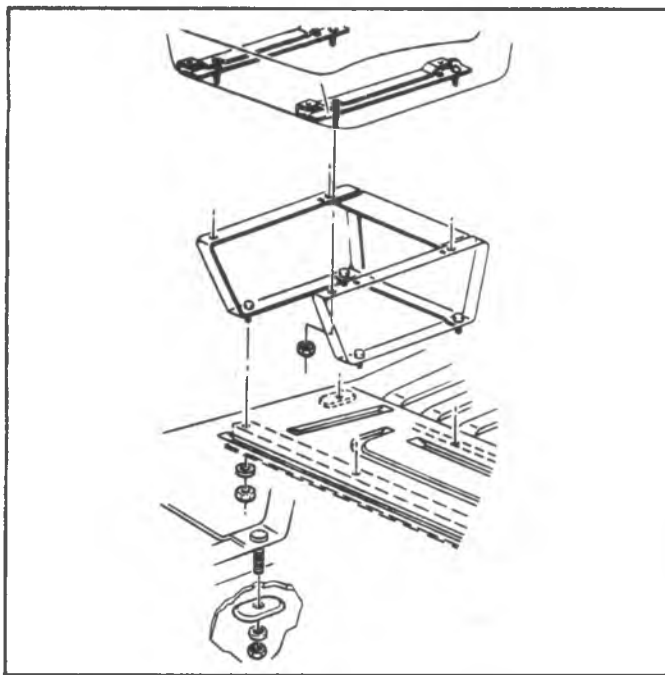

Fig. 2D-135-Passenger Seat

2. Remove brackets from seat.

#### Installation

1. Install brackets to seat. Torque to specifications.
2. Install seat to seat riser. Torque to specifications.

#### SEAT RISER

##### Removal

1. Remove seat and mounting bracket as an assembly.
2. Remove riser from floor.

##### Installation

1. Install riser to floor. Torque nuts to specifications.
2. Install seat riser. Torque nuts to specifications.

#### REAR BENCH SEATS

All models equipped with 2nd, 3rd and 4th bench seat assemblies feature a quick release mechanism which facilitates removal of the seats for added cargo space.

Instead of the conventional clamp and bolt method of seat retention, cam type latch assemblies and hooked

retainers, which fit onto anchor pins in floor anchor plates are used. When the latch assemblies are depressed, their cams and the hooks of the retainers are drawn tightly onto the anchor pins for secure seat attachment.

Removal is accomplished using the following procedure:

1. Pull up on quick release latches located at lower front of seat legs (right and left hand sides).
2. Tilt up front of seat and push seat rearward to clear anchor pins located beneath floor at front and rear of seat legs.
3. Lift seat up and remove from van.
4. To replace, reverse steps 1 to 3.

**NOTICE:** When replacing seats make sure that seat retainer hooks are fully engaged with anchor pins and latching assembly is fully depressed into place.

#### SWIVEL BUCKET SEATS - G MODELS

Refer to the illustration in Figure 2D-137 for swivel Bucket Seat Assembly installation.

#### ROOF VENT - G MODELS

Roof vent installation is illustrated in Figure 2D-138.

#### SERVICING LAP BELTS

Service precautionary items are outlined in the CK portion of this section.

**Internal drive thread-forming anchor bolts are used to secure lap belts to the floor pan. To remove or install internal drive anchor bolts, use door lock striker and lap belt anchor bolt removal tool J-23457 or equivalent. Start bolt by hand to assure that bolt is threaded straight.**

Refer to figures 2D-139 through 2D-141 and select the appropriate illustration for removing and installing lap belts.

#### DECAL APPLIQUE PROCEDURE

Refer to Section 2C, Chassis Sheet Metal, for procedure relating installation of decals or stripes.

#### ADHESIVE BODY SIDE MOLDING

Refer to Section 2C, Chassis Sheet Metal, for procedures relating to installation of adhesive moldings.

Fig. 2D-136-Quick Release Seat Assembly

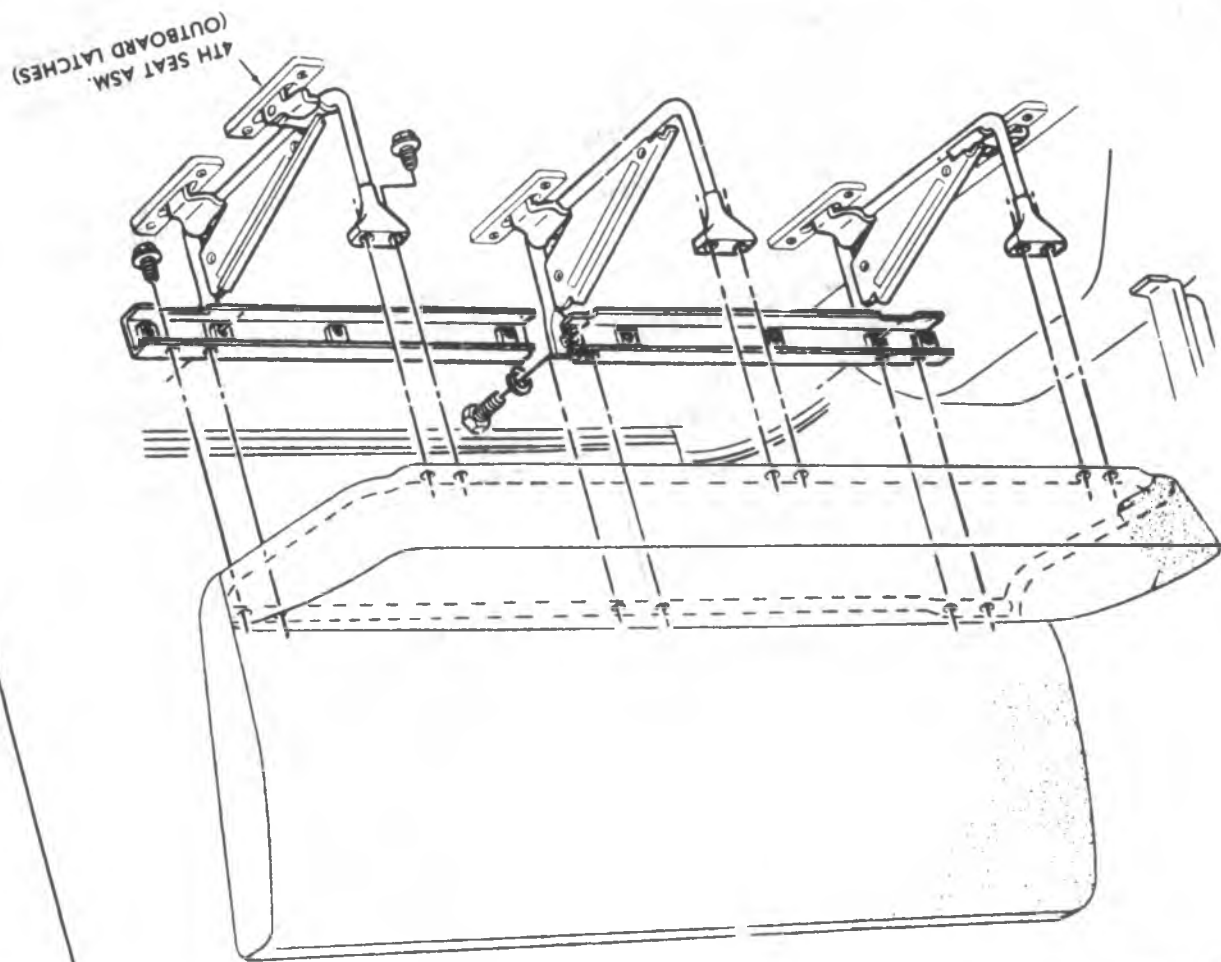
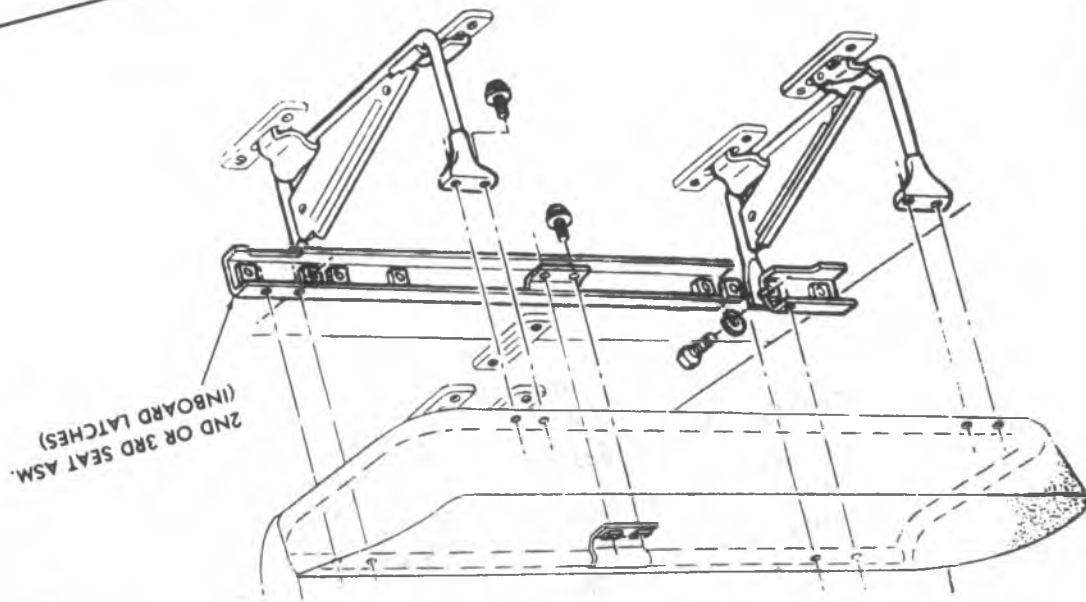

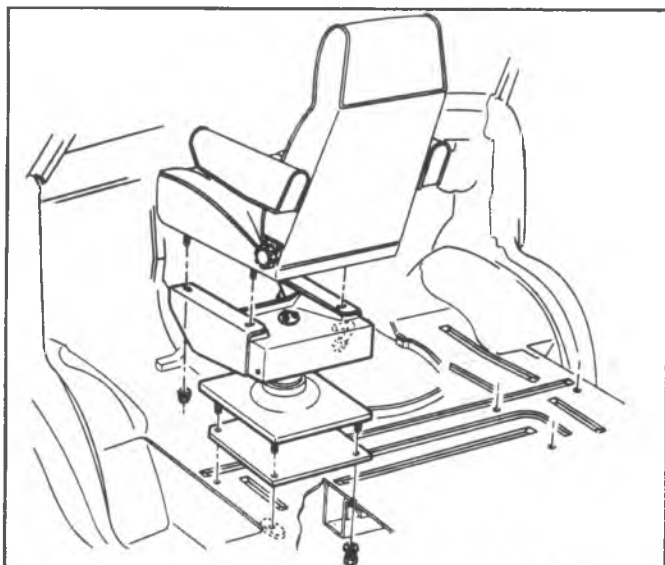

Fig. 2D-137--Swivel Bucket Seat Assembly - G Series

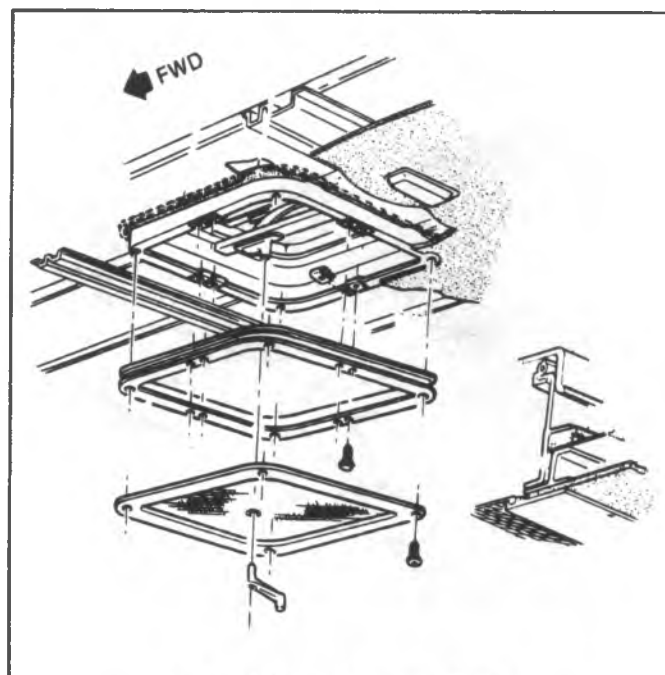

Fig. 2D-138--Roof Vent - G Series

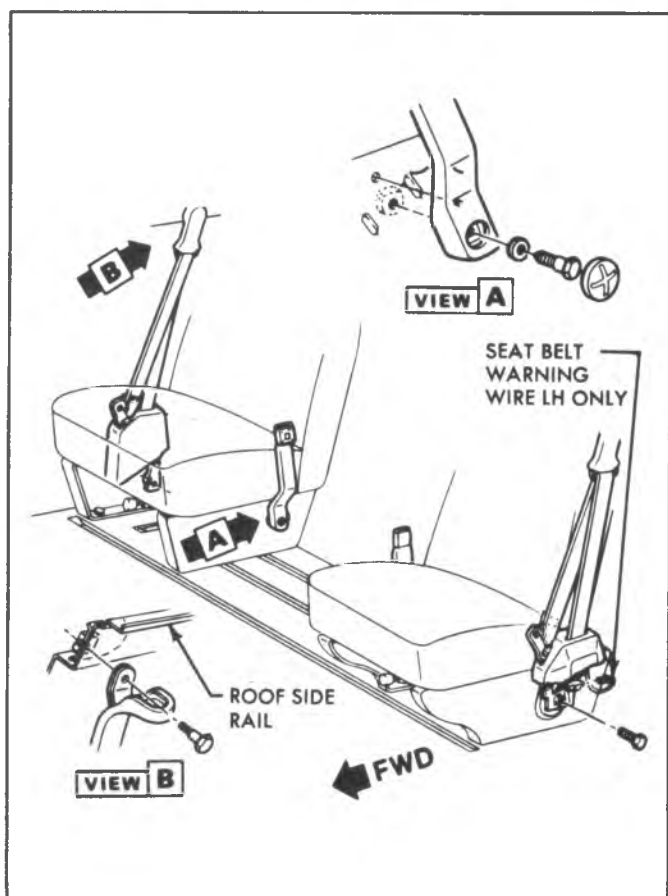

Fig. 2D-139--Front Seat Belt Installation

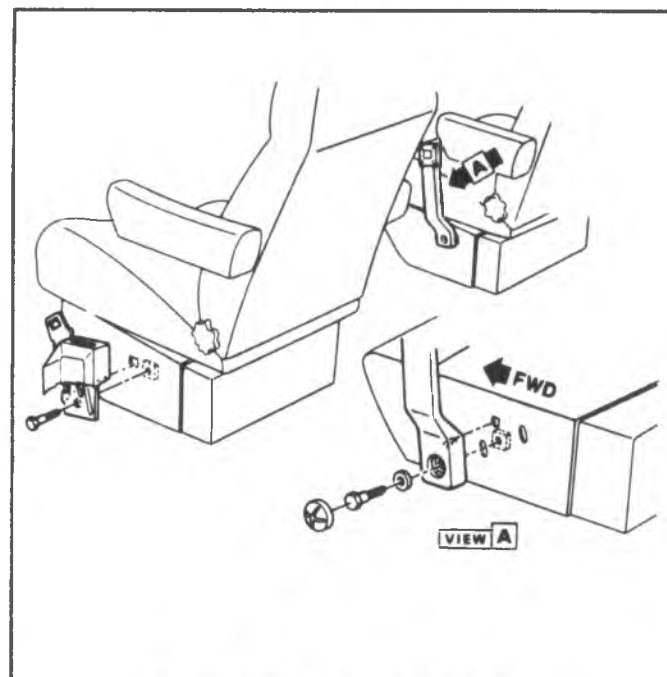

Fig. 2D-140--Seat Belt Swivel Bucket

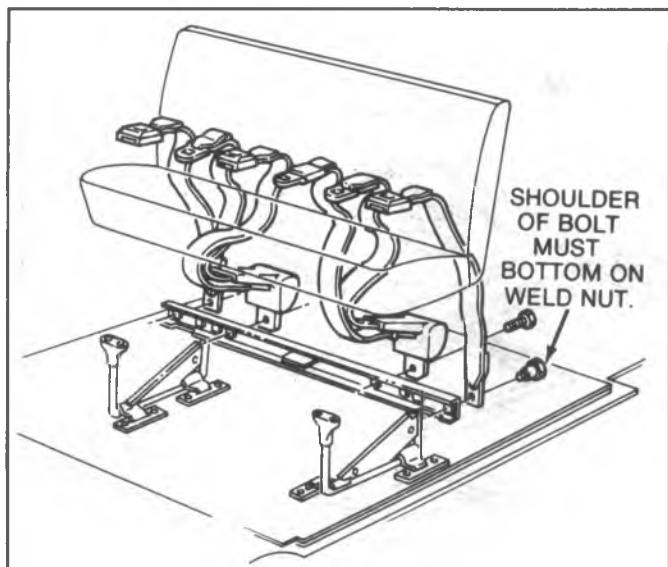

Fig. 2D-141--2nd and 3rd Seat Lap Belt Installation

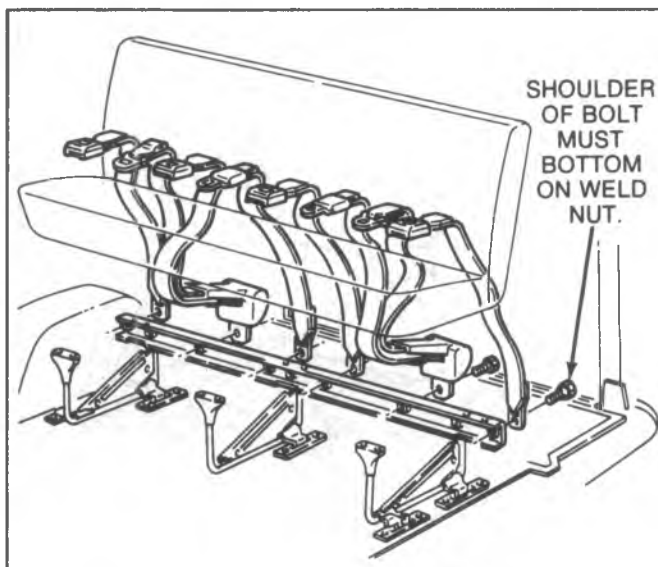

Fig. 2D-142--4th Seat Lap Belt Installation



**FRONT END**

|  |            |    |     |
|--|------------|----|-----|
| Sunshade Support.....                  | 18 in. lb. | 2. | N·m |
| Outside Rear View Mirror to Door Panel |            |    |     |
| Base Mirror.....                       | 18 in. lb. | 2. | N·m |
| West Coast Mirror-                     |            |    |     |
| Lower Bracket to Door.....             | 18 in. lb. | 2. | N·m |
| Upper Bracket to Door.....             | 18 in. lb. | 2. | N·m |

**DOORS**

|   |            |     |     |
|---|------------|-----|-----|
| Window Regulator Assembly                           |            |     |     |
| to Door Panel.....                                  | 85 in. lb. | 9.5 | N·m |
| Remote Control Door Lock                            |            |     |     |
| to Door Panel.....                                  | 45 in. lb. | 8.  | N·m |
| Lock Striker to Body Pillar.....                    | 45 ft. lb. | 60. | N·m |
| Outside Door Handle.....                            | 85 in. lb. | 9.5 | N·m |
| Inside Door Handle.....                             | 85 in. lb. | 9.5 | N·m |
| Hinges to Body and Door.....                        | 31 ft. lb. | 42. | N·m |
| Front Door-Window Rear Channel                      |            |     |     |
| Upper Bolt Assembly.....                            | 85 in. lb. | 9.5 | N·m |
| Lower Bolt Assembly.....                            | 85 in. lb. | 9.5 | N·m |
| Front Door-Ventilator and Glass Run Assembly        |            |     |     |
| Top Vent Screw.....                                 | 20 in. lb. | 2.2 | N·m |
| Side Vent Screws and Spacers.....                   | 22 in. lb. | 2.5 | N·m |
| Lower Vent Channel Bolts.....                       | 85 in. lb. | 9.5 | N·m |
| Side Rear Door-Run Channel                          |            |     |     |
| Front Upper Bolt to Door.....                       | 85 in. lb. | 9.5 | N·m |
| Rear Upper Screw to Door.....                       | 20 in. lb. | 2.  | N·m |
| Front Lower Nut to Door.....                        | 45 in. lb. | 5.  | N·m |
| Rear Lower Bolt to Door.....                        | 85 in. lb. | 9.5 | N·m |
| Lock Lever to Door.....                             | 85 in. lb. | 9.5 | N·m |
| Rear Door-  |            |     |     |
| Lock Striker (Suburban).....                        | 19 ft. lb. | 26. | N·m |
| Rear Door-Latch LH and RH                           |            |     |     |
| to Door (Suburban).....                             | 85 in. lb. | 9.5 | N·m |
| Rear Door-Latch Control Assembly to Door (Suburban) |            |     |     |
| Upper Assembly.....                                 | 19 ft. lb. | 26. | N·m |
| Lower Assembly.....                                 | 85 in. lb. | 9.5 | N·m |

**END GATE**

|                                       |            |     |     |
|---------------------------------------|------------|-----|-----|
| Hinges-Body Half and Gate Half.....   | 35 ft. lb. | 48. | N·m |
| Support Assembly-Cable Bolts.....     | 35 ft. lb. | 48. | N·m |
| Torque Rod to Hinge Pocket.....       | 85 in. lb. | 9.5 | N·m |
| Torque Rod to Body.....               | 18 ft. lb. | 2.  | N·m |
| Latch Assembly to End Gate.....       | 33 ft. lb. | 44. | N·m |
| Latch Control Assembly                |            |     |     |
| to End Gate.....                      | 45 in. lb. | 5.  | N·m |
| Handle to Latch Control Assembly..... | 45 in. lb. | 5.  | N·m |
| Glass Channel (Suburban).....         | 45 in. lb. | 5.  | N·m |
| Glass Channel (Utility).....          | 85 in. lb. | 9.5 | N·m |
| Outside Handle.....                   | 55 in. lb. | 6.  | N·m |
| Cap Assembly to Channel Assembly..... | 24 in. lb. | 2.6 | N·m |
| Striker-Body Mounted.....             | 25 ft. lb. | 34. | N·m |

**TAILGATE-FLEETSIDE**

|                               |            |     |     |
|-------------------------------|------------|-----|-----|
| Trunnion Assembly.....        | 18 ft. lb. | 24. | N·m |
| Linkage and Striker Assembly- |            |     |     |
| Support.....                  | 18 ft. lb. | 24. | N·m |

**TAILGATE-STEPSIDE**

|                             |            |     |     |
|-----------------------------|------------|-----|-----|
| Trunnion Assembly.....      | 18 ft. lb. | 24. | N·m |
| Chain Support Assembly..... | 90 in. lb. | 10. | N·m |

**SEATS**

|                              |             |     |     |
|------------------------------|-------------|-----|-----|
| Front Bench Seat             |             |     |     |
| Adjuster-to-Seat.....        | 50 in. lb.  | 17. | N·m |
| Adjuster-to-Floor.....       | 25 ft. lb.  | 34. | N·m |
| Front Bucket Type            |             |     |     |
| Driver                       |             |     |     |
| Adjuster-to-Seat.....        | 18 ft. lb.  | 24. | N·m |
| Adjuster-to-Floor.....       | 25 ft. lb.  | 34. | N·m |
| Passenger Chassis Cab        |             |     |     |
| Support-to-Seat.....         | 18 ft. lb.  | 24. | N·m |
| Support-to-Floor             |             |     |     |
| (Front).....                 | 25 ft. lb.  | 34. | N·m |
| Support-to-Floor             |             |     |     |
| (Rear).....                  | 40 ft. lb.  | 54. | N·m |
| Passenger Suburban           |             |     |     |
| Latch Support                |             |     |     |
| to Seat (Rear).....          | 18 ft. lb.  | 24. | N·m |
| Striker to Floor             |             |     |     |
| (Rear).....                  | 25 ft. lb.  | 34. | N·m |
| Support (Upper)              |             |     |     |
| to Seat (Front).....         | 18 ft. lb.  | 24. | N·m |
| Support (Lower)              |             |     |     |
| to Floor (Front).....        | 25 ft. lb.  | 34. | N·m |
| Support (Upper)              |             |     |     |
| to Support (Lower).....      | 30 ft. lb.  | 40. | N·m |
| Rear Bench Utility, Suburban |             |     |     |
| Support-to-Seat.....         | 18 ft. lb.  | 24. | N·m |
| Support-to-Floor.....        | 50 ft. lb.  | 70. | N·m |
| Rear Bench Crew Cab          |             |     |     |
| Support-to-Seat.....         | 150 in. lb. | 17. | N·m |
| Support-to-Floor.....        | 35 in. lb.  |     |     |
| Folding Rear Seat Suburban   |             |     |     |
| Support Asm-to-Floor.....    | 150 in. lb. | 17. | N·m |
| Seat-to-Support Asm.....     | 18 in. lb.  | 24. | N·m |

**BODY MOUNTING (C-K MODELS)**

| MODEL       | #1                   | #2                   | #3                   | #4                   | #5 | #6                   |
|-------------|----------------------|----------------------|----------------------|----------------------|----|----------------------|
| CHASSIS CAB | 55 ft. lb.<br>75 N·m | 55 ft. lb.<br>75 N·m |                      |                      |    |                      |
| CREW CAB    | 55 ft. lb.<br>75 N·m | 35 ft. lb.<br>48 N·m | 55 ft. lb.<br>75 N·m |                      |    |                      |
| SUBURBAN    | 55 ft. lb.<br>75 N·m | 35 ft. lb.<br>48 N·m |                      | 35 ft. lb.<br>48 N·m |    | 35 ft. lb.<br>48 N·m |
| UTILITY     | 55 ft. lb.<br>75 N·m | 45 ft. lb.<br>60 N·m | 35 ft. lb.<br>48 N·m | 35 ft. lb.<br>48 N·m |    |                      |

**G MODELS**

**MIRRORS AND SUNSHADE**

Outside Rear View Mirror to Panel...150 in. lb. 17. N·m  
Sunshade Support to Header Panel.....15 in. lb. 1.6 N·m

**SIDE WINDOW (SWINGOUT)**

Latch to Body.....40 in. lb. 4.6 N·m  
Hinge to Body.....55 in. lb. 6.0 N·m

**FRONT SIDE DOORS**

Door Hinges .....30 ft. lb. 40. N·m  
Remote Control Retaining Screws.....45 in. lb. 5. N·m  
Door Lock Striker.....45 ft. lb. 60. N·m  
Door Lock to Door .....22 ft. lb. 30. N·m  
Outside Door Handle.....90 in. lb. 10. N·m  
Regulator Assembly.....90 in. lb. 10. N·m

**REAR DOOR**

Hinge (to body and door).....40 ft. lb. 54. N·m  
Remote Control RH  
Retaining Screws .....70 in. lb. 8. N·m  
Latch-to-Door Retaining  
Screws Upper.....19 ft. lb. 26. N·m  
Latch-to-Door Retaining  
Screws Lower.....70 in. lb. 8. N·m  
Door Strikers-to-Body.....18 ft. lb. 24. N·m  
Outside Door Handle.....90 in. lb. 10. N·m

**SLIDING SIDE DOOR**

Remote Control (front latch)  
to Door.....90 in. lb. 10. N·m  
Rear Latch to Door.....90 in. lb. 10. N·m  
Lower Front Roller and Roller Support  
Support-to-Door.....24 ft. lb. 32. N·m  
Support to Roller Bracket .....24 ft. lb. 32. N·m  
Lower Control Assembly .....90 in. lb. 10. N·m  
Upper Front Roller Bracket  
Bracket to Door .....24 ft. lb. 32. N·m  
Roller to Bracket.....20 ft. lb. 27. N·m  
Upper Rear Hinge (Door Half)  
Hinge to Door .....25 ft. lb. 34. N·m  
Upper Rear Hinge (Body Half)  
Roller to Hinge.....20 ft. lb. 27. N·m  
Guide Block to Hinge.....45 in. lb. 5. N·m  
Lever Arm-to-Hinge  
Retaining Nut .....120 in. lb. 14. N·m  
Lever Retaining Screw .....45 in. lb. 5. N·m  
Rear Striker to Body (Upper Stop).....20 ft. lb. 27. N·m  
Rear Striker Bolt (Body Mounted).....45 ft. lb. 60. N·m  
Front Striker Retaining Screws  
(Body Mounted) .....90 in. lb. 10. N·m

**SEATS**

Seat Belt to Seat .....37 ft. lb. 50. N·m  
Passenger and Drivers  
Seat to Adjuster  
(Mounting Bracket) .....18 ft. lb. 24. N·m  
Seat to Riser.....18 ft. lb. 24. N·m  
Seat Riser-to-Floor .....50 ft. lb. 70. N·m  
Bench Seats  
Seat to Seat Support .....18 ft. lb. 24. N·m  
Seat Support to Leg Assembly.....130 ft. lb. 170 N·m

Keyliner Chart 2D-B--Specifications

Keyliner Chart 2D-B--Specifications

## SECTION 3

**STEERING, SUSPENSION, WHEELS AND TIRES**

|                            |       |
|----------------------------|-------|
| DIAGNOSIS.....             | 3-1   |
| FRONT END ALIGNMENT.....   | 3A-1  |
| STEERING LINKAGE.....      | 3B1-1 |
| MANUAL STEERING GEAR.....  | 3B2-1 |
| POWER STEERING SYSTEM..... | 3B3-1 |
| STEERING COLUMN.....       | 3B4-1 |
| FRONT SUSPENSION.....      | 3C-1  |
| REAR SUSPENSION.....       | 3D-1  |
| WHEELS AND TIRES.....      | 3E-1  |

**CONTENTS**

|                              |      |                          |      |
|------------------------------|------|--------------------------|------|
| Steering Linkage.....        | 3-2  | Man. Trans. Columns..... | 3-15 |
| Manual Steering Gear.....    | 3-4  | Tilt Columns.....        | 3-16 |
| Power Steering System.....   | 3-6  | Front Suspension.....    | 3-21 |
| System Noise.....            | 3-6  | Shock Absorbers.....     | 3-23 |
| System Operation.....        | 3-7  | Ball Joints.....         | 3-26 |
| Steering Columns.....        | 3-11 | Bearings and Races.....  | 3-27 |
| Auto. Transmission Cols..... | 3-11 |                          |      |

| CONDITION  | POSSIBLE CAUSE   | CORRECTION   |
|--|--|--|
| <p>Excessive Play or Looseness in Steering System.</p>   | <p>Front wheel bearings loosely adjusted.</p> <p>Worn steering shaft couplings.</p> <p>Worn upper ball joints.</p> <p>Steering wheel loose on shaft, loose pitman arm, tie rods, steering arms or steering linkage ball studs.</p> <p>Steering gear thrust bearings loosely adjusted.</p> <p>Excessive over-center lash in steering gear.</p> <p>Worn intermediate rod or tie rod sockets.</p> | <p>Adjust bearings to obtain proper end play.</p> <p>Replace part.</p> <p>Check and replace if necessary.</p> <p>Tighten to specified torque, or replace if necessary.</p> <p>Adjust preload to specification.</p> <p>Adjust preload to specification.</p> <p>Replace worn part.</p> |
| <p>Excessive looseness in tie rod or intermediate rod pivots, or excessive vertical lash in idler support.</p> | <p>Seal damage and leakage resulting in loss of lubricant, corrosion and excessive wear.</p>   | <p>Replace damaged parts as necessary. Properly position upon reassembly.</p>  |
| <p>Excessive vertical lash in idler arm (P Series Motorhome)</p>   | <p>Excessive end play in support assembly.</p>   | <p>Adjust end play.</p>  |

Fig. 3-1--Steering Linkage Diagnosis A

| CONDITION  | POSSIBLE CAUSE   | CORRECTION  |
|--|--|---|
| <p><b>Hard Steering – Excessive Effort Required at Steering Wheel.</b></p> | <p>Low or uneven tire pressure.</p> <p>Steering linkage or bolt joints need lubrication.</p> <p>Tight or frozen intermediate rod, tie rod or idler socket.</p> <p>Steering gear to column misalignment.</p> <p>Steering gear adjusted too tightly.</p> <p>Front wheel alignment incorrect. (manual gear)</p> | <p>Inflate to specified pressures.</p> <p>Lube with specified lubricant.</p> <p>Lube replace or reposition as necessary.</p> <p>Align column.</p> <p>Adjust over-center and thrust bearing preload to specification.</p> <p>Check alignment and correct as necessary.</p> |
| <p><b>Poor Returnability.</b></p>  | <p>Steering linkage or ball joints need lubrication.</p> <p>Steering gear adjusted too tightly.</p> <p>Steering gear to column misalignment.</p> <p>Front wheel alignment incorrect. (Caster)</p>  | <p>Lube with specified lubricant.</p> <p>Adjust over-center and thrust bearing preload to specifications.</p> <p>Align column.</p> <p>Check alignment and correct as necessary.</p>   |

Fig. 3-2--Steering Linkage Diagnosis B

| CONDITION                         | POSSIBLE CAUSE   | CORRECTION   |
|-----------------------------------|--|--|
| Rattle or Chuck in Steering Gear. | <p>Insufficient or improper lubricant in steering gear.</p> <p>Pitman arm loose on shaft or steering gear mounting bolt loose.</p> <p>Loose or worn steering shaft bearing.</p> <p>Excessive over-center lash or worm thrust bearings adjusted too loose.</p> <p>NOTE: On turns a slight rattle may occur, due to the increased lash between ball nut and pitman shaft as gear moves off the center of "high point" position. This is normal and lash must not be reduced to eliminate this slight rattle.</p> | <p>Add lube specified.</p> <p>Tighten to specified torque.</p> <p>Replace steering shaft bearing.</p> <p>Adjust steering gear to specified preloads.</p>     |
| Poor Returnability                | <p>Steering column misaligned.</p> <p>Insufficient or improper lubricant in steering gear or front suspension.</p> <p>Steering gear adjusted too tight.</p> <p>Front wheel alignment incorrect (Caster)</p>  | <p>Align column.</p> <p>Lubricate as specified.</p> <p>Adjust over-center and thrust bearing preload to specifications.</p> <p>Adjust to specifications.</p> |

Fig. 3-3--Manual Steering Gear Diagnosis A

| CONDITION  | POSSIBLE CAUSE   | CORRECTION   |
|--|--|--|
| <p>Excessive Play or Looseness in Steering System.</p>             | <p>Front wheel bearings loosely adjusted.</p> <p>Worn upper ball joints.</p> <p>Steering wheel loose on shaft, loose pitman arm, tie rods, steering arms or steering linkage ball nuts.</p> <p>Excessive over-center lash.</p> <p>Worm thrust bearings loosely adjusted.</p> | <p>Adjust to obtain proper end play.</p> <p>Check and replace ball joints if necessary.</p> <p>Tighten to specification, replace if worn or damaged.</p> <p>Adjust over-center preload to specifications.</p> <p>Adjust worm thrust bearing preload to specifications.</p> |
| <p>Hard Steering – Excessive Effort Required at Steering Wheel</p> | <p>Low or uneven tire pressure.</p> <p>Insufficient or improper lubricant in steering gear or front suspension.</p> <p>Steering shaft flexible coupling misaligned.</p> <p>Steering gear adjusted too tight.</p> <p>Front wheel alignment incorrect. (Manual Gear)</p>       | <p>Inflate to specified pressures.</p> <p>Lubricate as specified. Re-lubricate at specified intervals.</p> <p>Align column and coupling.</p> <p>Adjust over-center and thrust bearing preload to specifications.</p> <p>Adjust to specifications.</p>                      |

Fig. 3-4--Manual Steering Gear Diagnosis B

| CONDITION  | POSSIBLE CAUSE   | CORRECTION  |
|--|--|---|
| <p><b>SYSTEM NOISE</b></p> <p>There is some noise in all power steering systems.</p> <p>Common complaints are listed as follows:</p> |  |   |
| Pump noise-"chirp".  | Loose belt.  | Adjust belt tension to specification.   |
| Belt squeal.   | Loose belt.  | Adjust belt tension to specification.   |
| Gear noise ("hissing" sound)   | There is some noise in all power steering systems. One of the most common is a hissing sound most evident at standstill parking. There is no relationship between this noise and performance of the steering. "Hiss" may be expected when steering wheel is at end of travel or when slowly turning at standstill. | Do not replace valve unless "hiss" is extremely objectionable. Slight "hiss" is normal and in no way affects steering. A replacement valve will also exhibit slight noise and is not always a cure for the objection. Investigate clearance around flexible coupling rivets. Be sure steering shaft and gear are aligned so flexible coupling rotates in a flat plane and is not distorted as shaft rotates. Any metal-to-metal contacts through flexible coupling will transmit "hiss" into passenger compartment. Also, check for proper sealing between steering column and toe pan. |
| Rattle.  | Pressure hose touching other parts of car.<br><br>Loose pump pulley nut<br><br>Pump vanes not installed properly.<br><br>Pump vanes sticking in rotor slots.   | Adjust hose position.<br><br>Replace nut, torque to specs.<br><br>Install properly.<br><br>Free up by removing burrs, varnish or dirt.  |
| Gear noise (rattle or chuckle).  | Improper over-center adjustment<br><br>NOTE: A slight rattle may occur on turns because of increased clearance off the "high point". This is normal and clearance must not be reduced below specified limits to eliminate this slight rattle.<br><br>Loose pitman arm.<br><br>Gear loose on frame.                 | Adjust to specifications.<br><br><br><br><br><br>Tighten to specifications<br><br>Check gear-to-frame mounting bolts. Tighten bolts to 70 foot-pounds.  |
| Rattle or chuckle.   | Steering linkage looseness.  | Check linkage pivot points for wear. Replace if necessary.  |
| Groan.   | Low oil level.   | Fill reservoir to proper level.   |
| Groan.   | Air in the oil. Poor pressure hose connection.   | Bleed system by operating steering from right to left - full turn. Check connections, torque to specs.  |
| Growl.   | Excessive back pressure caused by hoses or steering gear. (restriction)  | Locate restriction and correct. Replace part if necessary.  |

Fig. 3-5--Power Steering System Diagnosis A



| CONDITION  | POSSIBLE CAUSE  | CORRECTION  |
|--|---|---|
| Pump growl<br>Note: Most noticeable at full wheel travel and stand still parking | Scored pump pressure plates, thrust plate or rotor.<br>Extreme wear of pump cam ring.   | Replace affected parts, flush system.<br>Replace affected parts.  |
| Swish in pump  | Defective pump flow control valve   | Replace valve   |
| Whine in pump  | Pump shaft bearing scored.  | Replace housing and shaft, flush system   |
| Squawk in gear (not belt)  | Damper "O" ring on valve spool cut  | Replace "O" ring.   |
| <b>SYSTEM OPERATION</b><br>Excessive wheel kick-back or loose steering.          | Backlash in steering linkage.<br>Air in system.<br>Excessive "over-center" lash.<br>Loose thrust bearing preload adjustment.<br>Worn poppet valve (Gear)<br>Steering gear loose on frame.<br>Steering gear flexible coupling too loose on shaft or rubber disc mounting screws loose.<br>Steering linkage ball studs worn enough to be loose.<br>Front wheel bearings incorrectly adjusted or worn. | Adjust parts affected or replace worn parts.<br>Add oil to pump reservoir and bleed by operating steering. Check all connections.<br>Adjust to specification.<br>Adjust to specification.<br>Replace poppet valve.<br>Tighten attaching bolts to 70 foot-pounds.<br>Tighten flange pinch bolts to 30 foot-pounds, if serrations are not damaged. Tighten upper flange to coupling nuts to 20 foot-pounds.<br>Replace loose components.<br>Adjust bearings or replace with new parts as necessary. |
| Poor return of steering.   | Tires under-inflated.<br>Lower coupling flange rubbing against steering gear adjuster plug.<br>Steering wheel rubbing against directional signal housing.<br>Tight or frozen steering shaft bearings.<br>Steering linkage or ball joints binding.<br>Steering gear to column misalignment.<br>Tie rod pivots not centralized.<br>Lack of lubricant in suspension ball joints and steering linkage   | Inflate to specified pressure.<br>Loosen pinch bolt and assemble properly.<br>Adjust steering jacket.<br>Replace bearings.<br>Replace affected parts.<br>Align steering column.<br>Adjust tie rod ends as required to center pivots.<br>Lubricate and relubricate at proper intervals   |

Fig. 3-6--Power Steering System Diagnosis B

| CONDITION  | POSSIBLE CAUSE  | CORRECTION   |
|--|---|--|
| Poor return of steering. (Cont'd.)   | <p>Steering gear adjustments over specifications.</p> <p>Sticky or plugged valve spool.</p> <p>Rubber spacer binding in shift tube.</p> <p>Improper front suspension alignment.</p> <p>Tight steering shaft bearings.</p>   | <p>Check adjustment with pitman arm disconnected. Readjust if necessary.</p> <p>Remove and clean or replace valve.</p> <p>Make certain spacer is properly seated. Lubricate inside diameter with silicone lubricant.</p> <p>Check and adjust to specifications.</p> <p>Replace bearings.</p> |
| Car leads to one side or the other. (Keep in mind road condition and wind. Test car on flat road going in both directions) | <p>Front suspension misaligned</p> <p>Steering shaft rubbing ID of shift tube.</p> <p>Unbalanced or badly worn steering gear valve.</p> <p><b>NOTE:</b> If this is cause, steering effort will be very light in direction of lead and heavy in opposite direction.</p> <p>Steering linkage not level.</p> | <p>Adjust to specifications.</p> <p>Align column.</p> <p>Replace valve.</p> <p>Adjust as required.</p>   |
| Steering wheel surges or jerks when turning with engine running especially during parking.                                 | <p>Low oil level in pump.</p> <p>Loose pump belt.</p> <p>Sticky flow control valve.</p> <p>Insufficient pump pressure.</p> <p>Steering linkage hitting engine oil pan at full turn.</p>   | <p>Check oil level, add as necessary.</p> <p>Adjust tension to specification.</p> <p>Inspect for varnish or damage, replace if necessary.</p> <p>Check pump pressure. (See pump pressure test). Replace relief valve if defective.</p> <p>Correct clearance.</p>                             |
| Momentary increase in effort when turning wheel fast to right or left.   | <p>Pump belt slipping.</p> <p>Low oil level in pump.</p> <p>High internal leakage.</p>  | <p>Tighten or replace belt.</p> <p>Check oil level, add as necessary.</p> <p>Check pump pressure (Test)</p>  |
| Hard steering or lack of assist.   | <p>High internal leakage. (Gear or pump)</p> <p>Loose pump belt.</p> <p>Low oil level in reservoir.</p>   | <p>Check pump pressure. (See pump pressure test).</p> <p>Adjust belt tension to specification.</p> <p>Fill to proper level. If excessively low, check all lines and joints for evidence of external leakage, torque to specs.</p>  |

Fig. 3-7--Power Steering System Diagnosis C

| CONDITION   | POSSIBLE CAUSE  | CORRECTION  |
|---|---|---|
| <p>Hard Steering or lack of assist (Continued)</p>                              | <p>Lack of lubricant in suspension or ball joints.</p> <p>Tires not properly inflated.</p> <p>Steering gear to column misalignment.</p> <p>Steering gear adjusted too tight.</p> <p>Excessive friction in steering linkage.</p> <p>Lower coupling flange rubbing against steering gear adjuster plug.</p> <p>Sticky flow control valve.</p> <p>Frame bent.</p> <p>Front springs weak and sagging.</p> <p>Insufficient oil pressure.</p> | <p>Lubricate, relubricate at proper intervals.</p> <p>Inflate to recommended pressure.</p> <p>Align steering column.</p> <p>Test steering system for binding with front wheels off floor. Adjust as necessary.</p> <p>Check tie rod pivot points for excessive friction. Replace the affected pivot.</p> <p>Loosen pinch bolt and assemble properly.</p> <p>Replace or clean valve.</p> <p>Check frame for proper alignment or cracking. Repair or replace as necessary.</p> <p>Check standing height. Weak or sagging springs should be replaced with new ones.</p> <p>If above checks do not reveal cause of hard steering, diagnose hydraulic system to determine problem.</p> |
| <p>Low oil pressure due to restriction in hoses:</p>                            | <p>Check for kinks in hoses.</p> <p>Foreign object stuck in hose.</p>   | <p>Remove kink.</p> <p>Remove hoses and remove restricting object or replace hose.</p>  |
| <p>Low oil pressure due to steering gear:<br/><br/>(See pump pressure test)</p> | <p>Pressure loss in cylinder due to worn piston ring or scored housing bore.</p> <p>Leakage at valve rings, valve body to worm seal.</p> <p>Loose fit of spool in valve body or leaky valve body.</p> <p>Damaged poppet valve.</p>  | <p>Remove gear from car for disassembly and inspection of ring and housing bore. Replace affected parts.</p> <p>Remove gear from car for disassembly and replace seals.</p> <p>Replace valve.</p> <p>Replace valve.</p>   |

Fig. 3-8--Power Steering System Diagnosis D

| CONDITION   | POSSIBLE CAUSE   | CORRECTION   |
|---|--|--|
| <p>Low oil pressure due to steering pump:<br/>(See pump pressure test.)</p> <p>Note: Steering system external leakage</p> <p>Foaming milky power steering fluid, low level and possible low pressure.</p> | <p>Loose belt.</p> <p>Low oil level.</p> <p>Air in the oil.</p> <p>Defective hoses or steering gear.</p> <p>Flow control valve stuck or inoperative.</p> <p>Loose screw in end of flow control valve.</p> <p>Cracked or broken thrust or pressure plate.</p> <p>Pressure plate not flat against cam ring.</p> <p>Extreme wear of cam ring.</p> <p>Scored pressure plate, thrust plate or rotor.</p> <p>Vanes not installed properly.</p> <p>Vanes sticking in rotor slots.</p> <p>Air in the fluid, and loss of fluid due to internal pump leakage causing overflow.</p> | <p>Adjust tension to specification</p> <p>Fill reservoir to proper level.</p> <p>Locate source of leak and correct. Bleed system.</p> <p>Correct as necessary.</p> <p>Remove burrs or dirt or replace.</p> <p>Tighten.</p> <p>Replace part.</p> <p>Replace pressure plate.</p> <p>Replace parts, flush system</p> <p>Replace parts. (If rotor, replace with rotating group kit), flush system</p> <p>Install properly. Radius edge to outside.</p> <p>Free-up by removing burrs, varnish or dirt.</p> <p>Check for leak and correct. Bleed system. Extremely cold temperatures will cause system aeration should the oil level be low. If oil level is correct and pump still foams, remove pump from vehicle and separate reservoir from housing. Check welsh plug and housing for cracks. If plug is loose or housing is cracked, replace housing.</p> |

Fig. 3-9--Power Steering System Diagnosis E

**Instrument Panel Bracket Capsule Damage**

**NOTE:** The bolt head must not contact surface "A". If contact is made, the capsule shear load will be increased. If this condition exists replace the bracket.

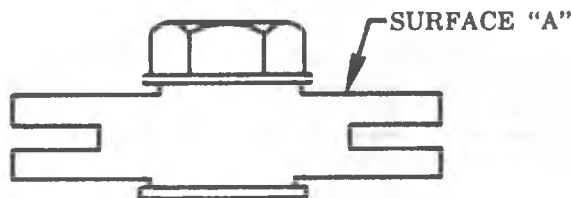

**AUTOMATIC TRANSMISSION COLUMNS**

**LOCK SYSTEM – WILL NOT UNLOCK**

| Cause                                      | Solution                            |
|--|-------------------------------------|
| A. Lock bolt damaged.                      | A. Replace lock bolt.               |
| B. Defective lock cylinder.                | B. Replace or repair lock cylinder. |
| C. Damaged housing.                        | C. Replace housing.                 |
| D. Damaged or collapsed sector.            | D. Replace sector.                  |
| E. Damaged rack.                           | E. Replace rack.                    |
| F. Shear Flange on sector shaft collapsed. | F. Replace.                         |

**LOCK SYSTEM WILL NOT LOCK**

| Cause   | Solution                           |
|---|------------------------------------|
| A. Lock bolt spring broken or defective.                  | A. Replace spring.                 |
| B. Damaged sector tooth, or sector installed incorrectly. | B. Replace, or install correctly.  |
| C. Defective lock cylinder.                               | C. Replace lock cylinder           |
| D. Burr or lock bolt or housing.                          | D. Remove Burr.                    |
| E. Damaged housing.                                       | E. Replace housing.                |
| F. Transmission linkage adjustment incorrect.             | F. Readjust (see Sec. 7).          |
| G. Damaged rack.  | G. Replace rack.                   |
| H. Interference between bowl and coupling (tilt).         | H. Adjust or replace as necessary. |
| I. Ignition switch stuck.                                 | I. Readjust or replace.            |
| J. Actuator rod restricted or bent.                       | J. Readjust or replace.            |

**LOCK SYSTEM – HIGH EFFORT**

| Cause  | Solution                   |
|--|----------------------------|
| A. Lock cylinder defective.  | A. Replace lock cylinder.  |
| B. Ignition switch defective.  | B. Replace switch.         |
| C. Rack preload spring broken or deformed.   | C. Replace spring.         |
| D. Burrs on sector, rack, housing, support, tang of shift gate or actuator rod coupling. | D. Remove Burr.            |
| E. Bent sector shaft.  | E. Replace shaft.          |
| F. Distorted rack.   | F. Replace rack            |
| G. Misalignment of housing to cover (tilt only).   | G. Replace either or both. |

Fig. 3-10--Auto Transmission Column Diagnosis A

| <b>LOCK SYSTEM – HIGH EFFORT (CONT'D.)</b>  |   |
|---|---|
| <b>Cause</b>  | <b>Solution</b>   |
| H. Distorted coupling slot in rack (tilt).<br>I. Bent or restricted actuator rod.<br>J. Ignition switch mounting bracket bent.  | H. Replace rack.<br>I. Straighten remove restriction or replace.<br>J. Straighten or replace. |
| <b>HIGH EFFORT LOCK CYLINDER – BETWEEN “OFF” AND “OFF-LOCK” POSITIONS</b>   |   |
| <b>Cause</b>  | <b>Solution</b>   |
| A. Burr on tang of shift gate.<br>B. Distorted rack.  | A. Remove burr.<br>B. Replace rack.   |
| <b>STICKS IN “START” POSITION</b>   |   |
| <b>Cause</b>  | <b>Solution</b>   |
| A. Actuator rod deformed.<br>B. Any high effort condition.  | A. Straighten or replace.<br>B. Check items under high effort section.                        |
| <b>KEY CAN NOT BE REMOVED IN “OFF-LOCK” POSITION</b>  |   |
| <b>Cause</b>  | <b>Solution</b>   |
| A. Ignition switch is not set correctly.<br>B. Defective lock cylinder.   | A. Readjust ignition switch.<br>B. Replace lock cylinder.                                     |
| <b>LOCK CYLINDER CAN BE REMOVED WITHOUT DEPRESSING RETAINER</b>   |   |
| <b>Cause</b>  | <b>Solution</b>   |
| A. Lock cylinder with defective retainer.<br>B. Lock cylinder without retainer.<br>C. Burr over retainer slot in housing cover. | A. Replace lock cylinder.<br>B. Replace lock cylinder.<br>C. Remove burr.                     |
| <b>LOCK BOLT HITS SHAFT LOCK IN “OFF” AND “PARK” POSITIONS</b>  |   |
| <b>Cause</b>  | <b>Solution</b>   |
| A. Ignition switch is not set correctly.  | A. Readjust ignition switch.  |
| <b>IGNITION SYSTEM – ELECTRICAL SYSTEM WILL NOT FUNCTION</b>  |   |
| <b>Cause</b>  | <b>Solution</b>   |
| A. Defective fuse in “accessory” circuit.<br>B. Connector body loose or defective.<br>C. Defective wiring.                      | A. Replace fuse.<br>B. Tighten or replace.<br>C. Repair or replace.                           |

Fig. 3-11—Auto Transmission Column Diagnosis B

**IGNITION SYSTEM – ELECTRICAL SYSTEM –  
WILL NOT FUNCTION (CONT'D.)**

| <b>Cause</b>   | <b>Solution</b>  |
|--|--|
| D. Defective ignition switch.<br>E. Ignition switch not adjusted properly.   | D. Replace ignition switch.<br>E. Readjust ignition switch.  |
| <b>SWITCH WILL NOT ACTUATE MECHANICALLY</b>  |  |
| <b>Cause</b>   | <b>Solution</b>  |
| A. Defective ignition switch.  | A. Replace ignition switch.  |
| <b>SWITCH CAN NOT BE SET CORRECTLY</b>   |  |
| <b>Cause</b>   | <b>Solution</b>  |
| A. Switch actuator rod deformed.<br>B. Sector to rack engaged in wrong tooth (tilt).   | A. Repair or replace switch actuator rod.<br>B. Engage sector to rack correctly.   |
| <b>NOISE IN COLUMN</b>   |  |
| <b>Cause</b>   | <b>Solution</b>  |
| A. Coupling bolts loose.<br>B. Column not correctly aligned.<br>C. Coupling pulled apart.<br>D. Sheared intermediate shaft plastic joint.<br>E. Horn contact ring not lubricated.<br>F. Lack of grease on bearings or bearing surfaces.<br>G. Lower shaft bearing tight or frozen.<br>H. Upper shaft tight or frozen.<br>I. Shaft lock plate cover loose.<br><br>J. Lock plate snap ring not seated.<br>K. Defective buzzer dog cam on lock cylinder.<br>L. One click when in "off-lock" position and the steering wheel is moved. | A. Tighten pinch bolts to specified torque.<br>B. Realign column.<br>C. Replace coupling and realign column.<br>D. Replace or repair steering shaft and realign column.<br>E. Lubricate with lubriplate.<br>F. Lubricate bearings.<br>G. Replace bearing. Check shaft and replace if scored.<br>H. Replace housing assembly.<br>I. Tighten three screws or, if missing, replace.<br><b>CAUTION: Use specified screws. (15 in. lbs.)</b><br>J. Replace snap ring. Check for proper seating in groove.<br>K. Replace lock cylinder.<br>L. Normal condition - lock bolt is seating. |

Fig. 3-12--Auto Transmission Column Diagnosis C

| <b>HIGH STEERING SHAFT EFFORT</b>  |  |
|--|--|
| <b>Cause</b>   | <b>Solution</b>  |
| <ul style="list-style-type: none"> <li>A. Column assembly misaligned in vehicle.</li> <li>B. Improperly installed or deformed dust seal.</li> <li>C. Tight or frozen upper or lower bearing.</li> <li>D. Flash on I.D. of shift tube from plastic joint.</li> </ul>  | <ul style="list-style-type: none"> <li>A. Realign.</li> <li>B. Remove and replace.</li> <li>C. Replace affected bearing or bearings.</li> <li>D. Replace shift tube.</li> </ul>  |
| <b>HIGH SHIFT EFFORT</b>   |  |
| <b>Cause</b>   | <b>Solution</b>  |
| <ul style="list-style-type: none"> <li>A. Column not aligned correctly in car.</li> <li>B. Improperly installed dust seal.</li> <li>C. Lack of grease on seal or bearing areas.</li> <li>D. Burr on upper or lower end of shift tube.</li> <li>E. Lower bowl bearing not assembled properly (tilt).</li> <li>F. Wave washer with burrs (tilt only).</li> </ul>   | <ul style="list-style-type: none"> <li>A. Realign.</li> <li>B. Remove and replace.</li> <li>C. Lubricate bearings and seals.</li> <li>D. Remove burr.</li> <li>E. Reassemble properly.</li> <li>F. Replace wave washer.</li> </ul>   |
| <b>IMPROPER TRANSMISSION SHIFTING</b>  |  |
| <b>Cause</b>   | <b>Solution</b>  |
| <ul style="list-style-type: none"> <li>A. Sheared shift tube joint.</li> <li>B. Improper transmission linkage adjustment.</li> <li>C. Loose lower shift lever.</li> <li>D. Improper gate plate.</li> <li>E. Sheared lower shift lever weld.</li> </ul>   | <ul style="list-style-type: none"> <li>A. Replace shift tube assembly.</li> <li>B. Readjust linkage.</li> <li>C. Replace shift tube assembly.</li> <li>D. Replace with correct part.</li> <li>E. Replace tube assembly.</li> </ul>   |
| <b>LASH IN MOUNTED COLUMN ASSEMBLY</b>   |  |
| <b>Cause</b>   | <b>Solution</b>  |
| <ul style="list-style-type: none"> <li>A. Instrument panel mounting bolts loose.</li> <li>B. Broken weld nuts on jacket.</li> <li>C. Instrument panel bracket capsule sheared.</li> <li>D. Instrument panel to jacket mounting bolts loose.</li> <li>E. Loose shoes in housing (tilt only).</li> <li>F. Loose tilt head pivot pins (tilt only).</li> <li>G. Loose shoe lock pin in support (tilt only).</li> </ul> | <ul style="list-style-type: none"> <li>A. Tighten to specifications. (20 ft. lbs.)</li> <li>B. Replace jacket assembly.</li> <li>C. Replace bracket assembly.</li> <li>D. Tighten to specifications. (15 ft. lbs.)</li> <li>E. Replace.</li> <li>F. Replace.</li> <li>G. Replace.</li> </ul> |
| <b>MISCELLANEOUS</b>   |  |
| <b>Cause</b>   | <b>Solution</b>  |
| <ul style="list-style-type: none"> <li>A. Housing loose on jacket - will be noticed with ignition in "Off-Lock" and a torque applied to the steering wheel.</li> <li>B. Shroud loose on shift bowl.</li> </ul>   | <ul style="list-style-type: none"> <li>A. Tighten four mounting screws - (60 in. lbs.)</li> <li>B. Bend tabs on shroud over lugs on bowl.</li> </ul>   |

Fig. 3-13--Auto Transmission Column Diagnosis D



## MANUAL TRANSMISSION COLUMNS

### GENERAL INFORMATION

All of the preceding diagnosis information for automatic transmission will apply to the manual transmission. The following information is supplied in addition to and specifically for manual transmission columns.

### DRIVER CAN LOCK STEERING IN SECOND GEAR

| Cause  | Solution   |
|--|--|
| <ul style="list-style-type: none"> <li>A. Defective upper shift lever.</li> <li>B. Defective shift lever gate.</li> <li>C. Loose relay lever on shift tube.</li> </ul> | <ul style="list-style-type: none"> <li>A. Replace shift lever.</li> <li>B. Replace shift lever gate.</li> <li>C. Replace shift tube assembly.</li> </ul> |

### HIGH SHIFT EFFORT

| Cause  | Solution   |
|--|--|
| <ul style="list-style-type: none"> <li>A. Column not aligned correctly in car.</li> <li>B. Lower bowl bearing not assembled correctly.</li> <li>C. Improperly installed seal.</li> <li>D. Wave washer in lower bowl bearing defective.</li> <li>E. Improper adjustment of lower shift levers.</li> <li>F. Lack of grease on seal, bearing areas or levers.</li> <li>G. Damaged shift tube in bearing areas.</li> </ul> | <ul style="list-style-type: none"> <li>A. Realign column.</li> <li>B. Reassemble correctly.</li> <li>C. Remove and replace.</li> <li>D. Replace wave washer.</li> <li>E. Readjust (see Sec. 7).</li> <li>F. Lubricate seal, levers and bearings.</li> <li>G. Replace shift tube assembly.</li> </ul> |

### IMPROPER TRANSMISSION SHIFTING

| Cause   | Solution  |
|---|---|
| <ul style="list-style-type: none"> <li>A. Loose relay lever on shift tube.</li> </ul> | <ul style="list-style-type: none"> <li>A. Replace shift tube assembly.</li> </ul> |

## TILT COLUMNS

### GENERAL INFORMATION

All of the preceding diagnosis will generally apply to tilt columns. The following is supplied in addition to and specifically for tilt columns.

#### HOUSING SCRAPING ON BOWL

| Cause                                    | Solution         |
|--|------------------|
| A. Bowl bent or not concentric with hub. | A. Replace bowl. |

#### STEERING WHEEL LOOSE

| Cause   | Solution                       |
|---|--------------------------------|
| A. Excessive clearance between holes in support or housing and pivot pin diameters. | A. Replace either or both.     |
| B. Defective or missing anti-lash spring in spheres.                                | B. Add spring or replace both. |
| C. Upper bearing seat not seating in bearing.                                       | C. Replace both.               |
| D. Upper bearing inner race seat missing.   | D. Install seat.               |
| F. Loose support screws.  | F. Tighten to 60 in. lbs.      |
| G. Bearing preload spring missing or broken.  | G. Replace preload spring.     |

#### STEERING WHEEL LOOSE EVERY OTHER TILT POSITION

| Cause   | Solution         |
|---|------------------|
| A. Loose fit between shoe and shoe pivot pin. | A. Replace both. |

#### NOISE WHEN TILTING COLUMN

| Cause                              | Solution                |
|------------------------------------|-------------------------|
| A. Upper tilt bumper worn.         | A. Replace tilt bumper. |
| B. Tilt spring rubbing in housing. | B. Lubricate.           |

#### STEERING COLUMN NOT LOCKING IN ANY TILT POSITION

| Cause                                   | Solution                       |
|---|--------------------------------|
| A. Shoe seized on its pivot pin.        | A. Replace shoe and pivot pin. |
| B. Shoe grooves may have burrs or dirt. | B. Replace shoe.               |
| C. Shoe lock spring weak or broken.     | C. Replace lock spring.        |

#### STEERING WHEEL FAILS TO RETURN TO TOP TILT POSITION

| Cause                                  | Solution                |
|--|-------------------------|
| A. Pivot pins are bound up.            | A. Replace pivot pins.  |
| B. Wheel tilt spring is defective.     | B. Replace tilt spring. |
| C. Turn signal switch wires too tight. | C. Reposition wires.    |

Fig. 3-15--Tilt Column Diagnosis

| <b>SIGNAL SWITCH DIAGNOSIS</b>             |   |   |
|--|---|---|
| <b>CONDITION</b>                           | <b>POSSIBLE CAUSE</b>   | <b>CORRECTION</b>   |
| Turn signal will not cancel                | <ul style="list-style-type: none"> <li>A. Loose switch mounting screws</li> <li>B. Switch or anchor bosses broken</li> <li>C. Broken, missing or out of position detent, return or cancelling spring</li> <li>D. Uneven or incorrect cancelling cam to cancelling spring interference. (.120)/side</li> </ul> | <ul style="list-style-type: none"> <li>A. Tighten to specified torque (25 in-lbs)</li> <li>B. Replace switch</li> <li>C. Reposition or replace springs as required</li> <li>D. Adjust switch position               <ul style="list-style-type: none"> <li>1. If interference is correct and switch will still not cancel, replace switch.</li> <li>2. If interference cannot be corrected by switch adjustment, replace cancelling cam.</li> </ul> </li> </ul> |
| Turn signal difficult to operate           | <ul style="list-style-type: none"> <li>A. Actuator rod loose</li> <li>B. Yoke broken or distorted</li> <li>C. Loose or misplaced springs</li> <li>D. Foreign parts and/or materials</li> <li>E. Switch mounted loosely</li> </ul>   | <ul style="list-style-type: none"> <li>A. Tighten mounting screw (12 in-lb)</li> <li>B. Replace switch</li> <li>C. Reposition or replace springs</li> <li>D. Remove foreign parts and/or material</li> <li>E. Tighten mounting screws (25 in-lbs)</li> </ul>  |
| Turn signal will not indicate lane change  | <ul style="list-style-type: none"> <li>A. Broken lane change pressure pad or spring hanger</li> <li>B. Broken, missing or misplaced lane change spring</li> <li>C. Jammed base or wires</li> </ul>  | <ul style="list-style-type: none"> <li>A. Replace switch</li> <li>B. Replace or reposition as required</li> <li>C. Loosen mounting screws, reposition base or wires and retighten screws (25 in-lbs)</li> </ul>   |
| Turn signal will not stay in turn position | <ul style="list-style-type: none"> <li>A. Foreign material or loose parts impeding movement of yoke</li> <li>B. Broken or missing detent or cancelling springs</li> <li>C. None of the above</li> </ul>   | <ul style="list-style-type: none"> <li>A. Remove material and/or parts</li> <li>B. Replace spring</li> <li>C. Replace switch</li> </ul>   |
| Hazard switch cannot be turned off         | <ul style="list-style-type: none"> <li>A. Foreign material between hazard support cancelling leg and yoke</li> </ul>  | <ul style="list-style-type: none"> <li>A. Remove foreign material               <ul style="list-style-type: none"> <li>1. No foreign material impeding function of hazard switch – replace turn signal switch</li> </ul> </li> </ul>  |

Fig. 3-16--Turn Signal Switch Diagnosis A

| <b>SIGNAL SWITCH DIAGNOSIS</b>                          |   |  |
|---|---|--|
| <b>CONDITION</b>  | <b>POSSIBLE CAUSE</b>   | <b>CORRECTION</b>  |
| Hazard switch will not stay on or difficult to turn off | <ul style="list-style-type: none"> <li>A. Loose switch mounting screws</li> <li>B. Interference with other components</li> <li>C. Foreign material</li> <li>D. None of the above</li> </ul>   | <ul style="list-style-type: none"> <li>A. Tighten mounting screws (25 in-lbs)</li> <li>B. Remove interference</li> <li>C. Remove foreign material</li> <li>D. Replace switch</li> </ul>  |
| No turn signal lights                                   | <ul style="list-style-type: none"> <li>A. Defective or blown fuse</li> <li>B. Inoperative turn signal flasher</li> <li>C. Loose chassis to column connector</li> <li>D. Disconnect column to chassis connector. Connect new switch to chassis and operate switch by hand. If vehicle lights now operate normally, signal switch is inoperative</li> <li>E. If vehicle lights do not operate check chassis wiring for opens, grounds, etc.</li> </ul>  | <ul style="list-style-type: none"> <li>A. Replace fuse and check operation</li> <li>B. Replace turn signal flasher</li> <li>C. Connect securely, check operation</li> <li>D. Replace signal switch</li> <li>E. Repair chassis wiring as required using manual as guide</li> </ul>  |
| Turn indicator lights on, but not flashing              | <ul style="list-style-type: none"> <li>A. Inoperative turn flasher</li> <li>B. Loose chassis to column connection</li> <li>C. Inoperative turn signal switch</li> <li>D. To determine if turn signal switch is defective, substitute new switch into circuit and operate switch by hand. If the vehicle's lights operate normally, signal switch is inoperative</li> <li>E. If the vehicle's lights do not operate, check light sockets for high resistance connections, the chassis wiring for opens, grounds, etc.</li> </ul> | <ul style="list-style-type: none"> <li>A. Replace turn flasher<br/>Note: There are two flashers in the system. Consult manual for location.</li> <li>B. Connect securely and check operation</li> <li>C. Replace turn signal switch</li> <li>D. Replace signal switch</li> <li>E. Repair chassis wiring as required using manual as guide</li> </ul> |

Fig. 3-17--Turn Signal Switch Diagnosis B

| <b>SIGNAL SWITCH DIAGNOSIS</b>                |  |   |
|---|--|---|
| <b>CONDITION</b>                              | <b>POSSIBLE CAUSE</b>  | <b>CORRECTION</b>   |
| Front or rear turn signal lights not flashing | <ul style="list-style-type: none"> <li>A. Burned out fuse</li> <li>B. Burned out or damaged turn signal bulb</li> <li>C. High resistance connection to ground at bulb socket</li> <li>D. Loose chassis to column connector</li> <li>E. Disconnect column to chassis connector. Connect new switch into system and operate switch by hand. If turn signal lights are now on and flash, turn signal switch is inoperative.</li> <li>F. If vehicle lights do not operate, check chassis wiring harness to light sockets for opens, grounds, etc.</li> </ul> | <ul style="list-style-type: none"> <li>A. Replace fuse and check operation</li> <li>B. Replace bulb</li> <li>C. Remove or repair defective connection and check operation</li> <li>D. Connect securely and check operation</li> <li>E. Replace turn signal switch.</li> <li>F. Repair chassis wiring as required using manual as guide</li> </ul> |
| Stop light not on when turn indicated         | <ul style="list-style-type: none"> <li>A. Burned out fuse</li> <li>B. Loose column to chassis connection</li> <li>C. Disconnect column to chassis connector. Connect new switch into system without removing old. Operate switch by hand. If brake lights work with switch in the turn position, signal switch is defective</li> <li>D. If brake lights do not work check connector to stop light sockets for grounds, opens, etc.</li> </ul>  | <ul style="list-style-type: none"> <li>A. Replace fuse and check operation</li> <li>B. Connect securely and check operation</li> <li>C. Replace signal switch</li> <li>D. Repair connector to stop light circuits using manual as guide.</li> </ul>   |
| Turn indicator panel lights not flashing      | <ul style="list-style-type: none"> <li>A. Burned out bulbs</li> <li>B. High resistance to ground at bulb socket</li> <li>C. Opens, grounds in wiring harness from front turn signal bulb socket to indicator lights</li> </ul>   | <ul style="list-style-type: none"> <li>A. Replace bulbs</li> <li>B. Replace socket</li> <li>C. Locate and repair as required. Use shop manual as guide.</li> </ul>  |

Fig. 3-18--Turn Signal Switch Diagnosis C

| <b>SIGNAL SWITCH DIAGNOSIS</b>  |   |  |
|---|---|--|
| <b>CONDITION</b>  | <b>POSSIBLE CAUSE</b>   | <b>CORRECTION</b>  |
| <p>Turn signal lights flash very slowly</p>                                 | <p>A. Inoperative turn signal flasher</p> <p>B. System charging voltage low</p> <p>C. High resistance ground at light sockets</p> <p>D. Loose chassis to column connection</p> <p>E. Disconnect column to chassis connector. Connect new switch into system without removing old. Operate switch by hand. If flashing occurs at normal rate, the signal switch is defective.</p> <p>F. If the flashing rate is still extremely slow, check chassis wiring harness from the connector to light sockets for grounds, high resistance points, etc.</p> | <p>A. Replace turn signal flasher</p> <p>B. Increase voltage to specified. See Sec. 6Y</p> <p>C. Repair high resistance grounds at light sockets</p> <p>D. Connect securely and check operation</p> <p>E. Replace signal switch</p> <p>F. Locate and repair as required. Use manual as guide. See Section 12</p> |
| <p>Hazard signal lights will not flash — turn signal functions normally</p> | <p>A. Blown fuse</p> <p>B. Inoperative hazard warning flasher</p> <p>C. Loose chassis to column connection</p> <p>D. Disconnect column to chassis connector. Connect new switch into system without removing old. Depress the hazard warning button and observe the hazard warning lights. If they now work normally, the turn signal switch is defective.</p> <p>E. If the lights do not flash, check wiring harness "K" lead (brown) for open between hazard flasher and harmonica connector. If open, fuse block is defective.</p>               | <p>A. Replace fuse and check operation</p> <p>B. Replace hazard warning flasher</p> <p>C. Connect securely and check operation</p> <p>D. Replace the turn signal switch</p> <p>E. Replace fuse block (See Sec. 12)</p>   |

Fig. 3-19--Turn Signal Switch Diagnosis D

## FRONT SUSPENSION DIAGNOSIS

### HARD STEERING

| Probable Cause                                       | Probable Remedy   |
|--|---|
| a. Ball joints and steering linkage need lubrication | a. Lubricate ball joints and linkage                    |
| b. Low or uneven front tire pressure                 | b. Inflate tires to the proper recommended pressure     |
| c. Power steering partially or not operative         | c. Check power steering components for proper operation |
| d. Steering gear not properly adjusted               | d. Adjust steering gear                                 |
| e. Incorrect front wheel alignment (manual steering) | e. Check and align front suspension                     |

### POOR DIRECTIONAL STABILITY

|  |   |
|--|---|
| a. Ball joints and steering linkage need lubrication | a. Lubricate at proper intervals                    |
| b. Low or uneven front or rear tire pressure         | b. Inflate tires to the proper recommended pressure |
| c. Loose wheel bearings                              | c. Adjust wheel bearings                            |
| d. Steering Gear not on high point                   | d. Adjust steering gear                             |
| e. Incorrect front wheel alignment (caster)          | e. Check and align front suspension                 |
| f. Broken springs                                    | f. Replace springs                                  |
| g. Malfunctioning shock absorber.                    | g. Diagnose shock absorbers.                        |
| h. Broken stabilizer bar, or missing link            | h. Replace stabilizer or link                       |

### FRONT WHEEL SHIMMY (SMOOTH ROAD SHAKE)

|   |                                 |
|---|---------------------------------|
| a. Tire and wheel out of balance, or out of round | a. Balance tires, check run-out |
| b. Worn or loose wheel bearings                   | b. Adjust wheel bearings        |
| c. Worn tie rod ends                              | c. Replace tie rod end          |
| d. Worn ball joints                               | d. Replace ball joints          |
| e. Malfunctioning shock absorber                  | e. Diagnose shock absorbers     |

### VEHICLE PULLS TO ONE SIDE (NO BRAKING ACTION)

|   |   |
|---|---|
| a. Low or uneven tire pressure              | a. Inflate tires to the proper recommended pressure |
| b. Front or rear brake dragging             | b. Adjust brakes                                    |
| c. Broken or sagging front spring           | c. Replace spring                                   |
| d. Incorrect front wheel alignment (camber) | d. Check and align front suspension                 |

### EXCESSIVE PLAY IN STEERING

|                                       |                         |
|---------------------------------------|-------------------------|
| a. Incorrect steering gear adjustment | a. Adjust steering gear |
| b. Worn steering gear parts           | b. Overhaul gear        |

**NOISE IN FRONT END****Probable Cause**

- a. Ball joints and steering linkage need lubrication
- b. Shock absorber loose or bushings worn
- c. Worn control arm bushings
- d. Worn tie rod ends
- e. Worn or loose wheel bearings
- f. Loose stabilizer bar
- g. Loose wheel nuts
- h. Spring improperly positioned
- i. Loose suspension bolts

**Probable Remedy**

- a. Lubricate at recommended intervals
- b. Tighten bolts and/or replace bushings
- c. Replace bushings
- d. Replace tie rod ends
- e. Adjust or replace wheel bearings
- f. Tighten all stabilizer bar attachments
- g. Tighten the wheel nuts to proper torque
- h. Reposition
- i. Torque to specifications or replace

**WHEEL TRAMP**

- a. Tire and wheel out of balance
- b. Tire and wheel out of round
- c. Blister or bump on tire
- d. Improper shock absorber action

- a. Balance wheels
- b. Replace tire
- c. Replace tire
- d. Replace shock absorber

**EXCESSIVE OR UNEVEN TIRE WEAR**

- a. Underinflated or overinflated tires
- b. Improper toe-in
- c. Wheels out of balance
- d. Hard Driving
- e. Overloaded vehicle

- a. Inflate tire to proper recommended pressure
- b. Adjust toe-in
- c. Balance wheels
- d. Instruct driver
- e. Instruct driver

**SCUFFED TIRES**

- a. Toe-in incorrect
- b. Excessive speed on turns
- c. Tires improperly inflated
- d. Suspension arm bent or twisted

- a. Adjust toe-in to specifications
- b. Advise driver
- c. Inflate tires to proper recommended pressure
- d. Replace arm

**CUPPED TIRES**

- a. Front shock absorbers defective
- b. Worn ball joints
- c. Wheel bearings incorrectly adjusted or worn
- d. Wheel and tire out of balance
- e. Excessive tire or wheel runout

- a. Replace shock absorbers
- b. Replace ball joints
- c. Adjust or replace wheel bearings
- d. Balance wheel and tire
- e. Compensate for runout



## SHOCK ABSORBER DIAGNOSIS

### ON VEHICLE CHECKS

(Follow the Procedures Outlined Below in the Order Indicated.)

#### Preliminary Inspection and Ride Test:

##### Tire Pressure

Check tire pressure, compare to vehicle specifications and adjust as required. Poor vehicle control and ride complaints are caused in many cases by improper tire inflation.

##### Special Suspension Equipment

Check Service Parts Identification Sticker for any special suspension equipment; such as, a heavy duty suspension. Vehicles equipped with this type of option have a somewhat stiffer or harsh ride, and this should be kept in mind during the following tests. If complaint about stiffness should occur while vehicle is still new (under 5,000 miles) (8 000 km), owner should be advised to have ride rechecked after 7,000 to 8,000 miles (11 200 to 12 800 km).

##### Vehicle Load Conditions

Note any exceptional load conditions under which the owner normally operates the vehicle; such as, large tool boxes full of tools, pick up bed full etc. If exceptional loading is apparent, check the distribution of this weight. Note if it is all toward one side of the vehicle or at the extreme rear of the vehicle. Reposition load as required to obtain a more uniform weight distribution.

##### Check Vehicle Ride and Handling

After completing previous checks, ride vehicle with owner to determine if problem has been corrected or to definitely establish type of problem that still exists. If problem still exists (poor handling, bottoming, noise, ride sway, etc.), proceed.

##### Inspecting and Testing the Shocks

Three procedures are included in this step. They are (a) Bounce Test, (b) Inspecting Shock Mountings for Noise (Looseness) and (c) Manually Operating Shocks to Determine if Shocks are Weak, Leaking Hydraulic Fluid, and/or if Shocks have an Internal Noise Condition.

Test procedures (b) and (c) require vehicle to be on a hoist that supports wheels or rear axle housing and front lower control arms.

##### Bounce Test

This is only a comparison type test to help locate the suspected shock or noise condition before proceeding.

Test each front and rear shock by bouncing each corner of the vehicle. This can usually be done by lifting up and pushing down on the end of the bumper near each corner of the vehicle until maximum movement up and down is reached. Then let go of bumper and observe if the up and down motion stops very quickly. If up and down motion continues longer at one corner when compared to opposite corner (example, both front shocks), the one having the longer up and down motion may be suspect. **Do Not** compare front to rear. If complaint is noise, this test should help to locate the suspected area.

##### Inspecting Shock Mountings

If noisy and/or loose shock mountings are suspected, place vehicle on hoist that supports wheels and check all mountings for the following conditions:

- (1) Worn or defective grommets
- (2) Loose mounting nuts
- (3) Possible interference condition
- (4) Bump stops missing

If no apparent defects are noted in this step but noise condition still exists when vehicle is bounced up and down, proceed.

##### Inspecting Shocks for Leaks and

##### Manually Operating Shocks

This procedure is subdivided into two general areas, (1) Inspecting Shocks for Loss of Hydraulic Fluid and (2) Manually Operating Shock. It should aid the technician to localize defective shocks caused by internal noise in the shock, weakness, leaking etc.

##### 1. Inspecting Shocks for Possible Loss of Hydraulic Fluid.

- (a) Disconnect each shock lower mounting as required and pull down on the shock until it is fully extended.
- (b) Inspect shocks for leaks in seal cover area. Shock fluid is a very thin hydraulic fluid and has a characteristic odor and dark brown tint.

Certain precautions should be observed when inspecting shocks for leaks:

- shocks may have glossy paint on them. Do not confuse this paint with a leak condition.
- a slight trace of shock fluid around the seal cover area is **not** cause for replacement. The shock seal is engineered to permit a slight seepage to lubricate the rod. The shock absorber has reserve fluid to compensate for the slight seepage.
- shocks are sometimes incorrectly diagnosed as leakers due to oil spray originating from some other source. If in doubt, wipe the wet area from and manually operate shock as described in Step (2). Fluid will reappear if shock is leaking.

103404

Fig. 3-22--Shock Absorber Diagnosis

## 2. Manually operating shocks.

It may be necessary with certain types of shock mountings to fabricate a bracket that can be installed on a shock to enable a technician to securely grip the shock when manually operating the shock. See Figure 3C-9 for suggested methods of providing temporary grip.

This test should help the mechanic to isolate the following shock defects:

- binding condition internally
- verify leaking shock
- improper or defective valving

(a) If suspected problem is in front shocks, disconnect both front shock lower mountings and stroke each shock as follows: Grip the lower end of the shock securely and pull down (rebound stroke) then push up (compression stroke). The control arms will limit the movement of the front shocks during the compression stroke. Compare the rebound resistance between both front shocks, then compare the compression resistance. If a noticeable difference can be felt during either stroke, usually the shock having the least resistance is at fault.

(b) If shock has an internal noise condition, extend shock fully, then exert an extra pull. If noisy, shock should be replaced.

Other noise conditions that require shock replacement are:

- a grunt or squeal after one full stroke in both directions
- a clicking noise on fast reverse
- a skip or lag at reversal near mid-stroke

When air adjustable shocks are being manually operated, the air line must be disconnected at the shock absorber.

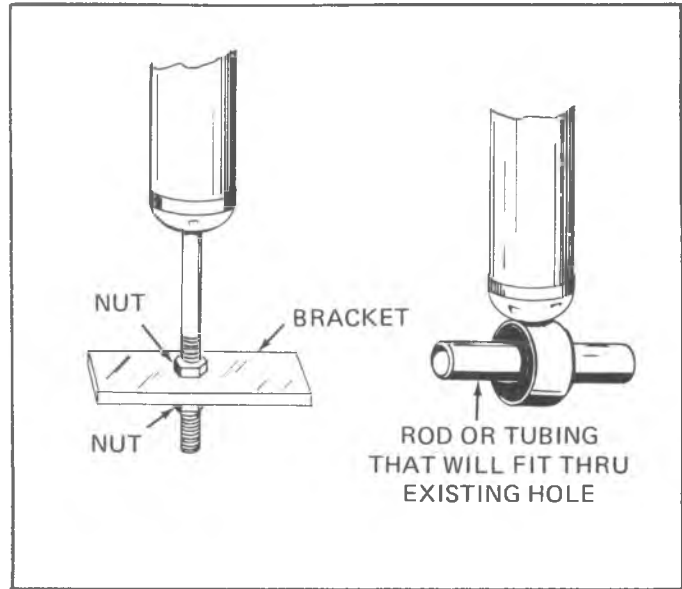

Gripping Methods

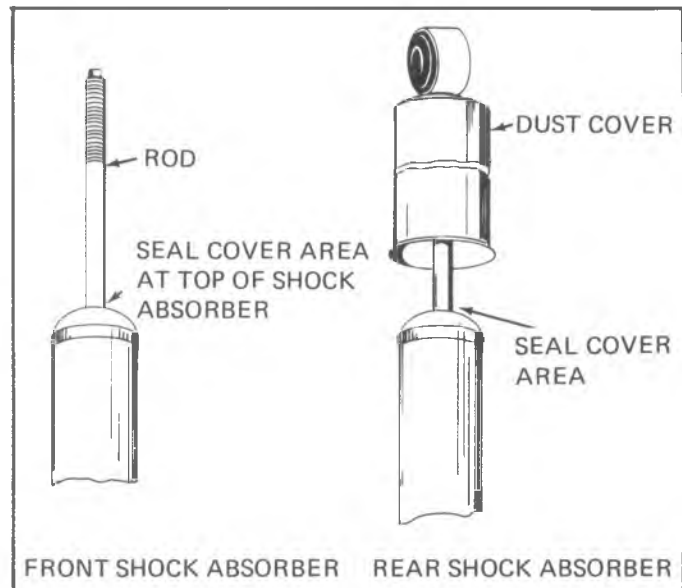

Seal Cover Area of Shock

## BENCH CHECKS

The bench checks are recommended if the proper type hoist is not available to perform the "on vehicle" tests, or if there is still some doubt as to whether the shocks are defective. In addition, the bench test allows a more thorough visual inspection.

Bench check procedures are discussed for three general types of shocks.

### SPIRAL GROOVE RESERVOIR

If this type of shock has been stored or allowed to lay in a horizontal position for any length of time, an air void will develop in the pressure chamber of the shock absorber. This air void if not purged, can cause a technician to diagnose the shock as defective. To purge the air from the pressure chamber, proceed as follows:

- Holding the shock in its normal vertical position (top end up), fully extend shock.
- Hold the top end of the shock down and fully collapse the shock.
- Repeat Steps (a) and (b) at least five (5) times to assure air is purged.

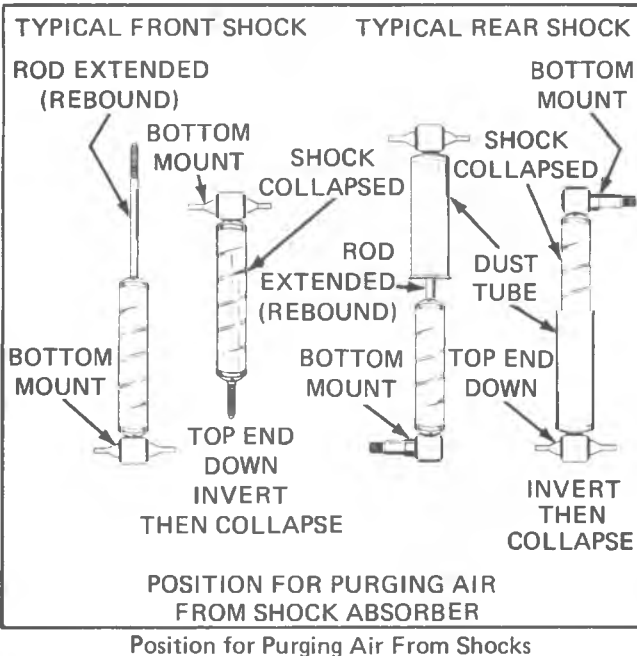

### Bench Test Procedure

- This is a comparison type test. If possible, obtain a new or known good shock with same part number as shock under test.
- With shocks in vertical position (top end up), clamp bottom mounts in vise. Do not clamp on reservoir tube or mounting threads.

- Manually pump each shock by hand at various rates of speed and compare resistance of suspected shock with the new one.

Rebound resistance (extending the shock) is normally stronger than the compression resistance (approximately 2:1). However, resistance should be smooth and constant for each stroking rate.

- Observe or listen for the following conditions that will indicate a defective shock:
  - a skip or lag when reversing stroke at mid travel.
  - seizing or binding condition except at extreme end of either stroke.
  - a noise, such as a grunt or squeal, after completing one full stroke in both directions.
  - a clicking type noise at fast reversal.
  - fluid leakage.
- To check for a loose piston, completely extend shock to full rebound; then exert an extra hard pull. If a give is felt, a loose piston is indicated and shock should be replaced.

### PLIACELL OR GENETRON

Pliacell and Genetron are some of the trade names used to indicate a gas-filled cell in the shock reservoir. The reservoirs of Pliacell and Genetron shocks are smooth, compared to the spiral groove type. The cell takes the place of air in the reservoir. Thus, aeration or foaming of the fluid is eliminated, as air and fluid cannot mix.

Due to this feature, these shocks should be bench checked in an **inverted position** (top end down). If, when stroked, a lag is noticed, it means the gas-filled cell has been ruptured, and the shock should be replaced. If no lag is noticed, the remainder of the bench check is the same as given in the Spiral Groove Reservoir, Section 1, Bench Check Procedure.

### AIR ADJUSTABLE SHOCKS

This type of shock contains an air chamber like the spiral groove reservoir type, and must have the air purged from the working chamber. See Section 1, Spiral Groove Reservoir. After air has been purged from shock, proceed as follows:

- Clamp lower shock mounting ring in vise in vertical position with larger diameter tube at the top.
- Pump unit by hand at different rates of speed. Smooth resistance should be felt through the length of the stroke. Since the units are normally pressurized, the sound of air bubbles or a gurgling noise is **normal**.
- The remainder of the bench check is the same as given in the Spiral Groove Reservoir, Section 1, Bench Check Procedure.

BALL JOINT DIAGNOSTIC PROCEDURE

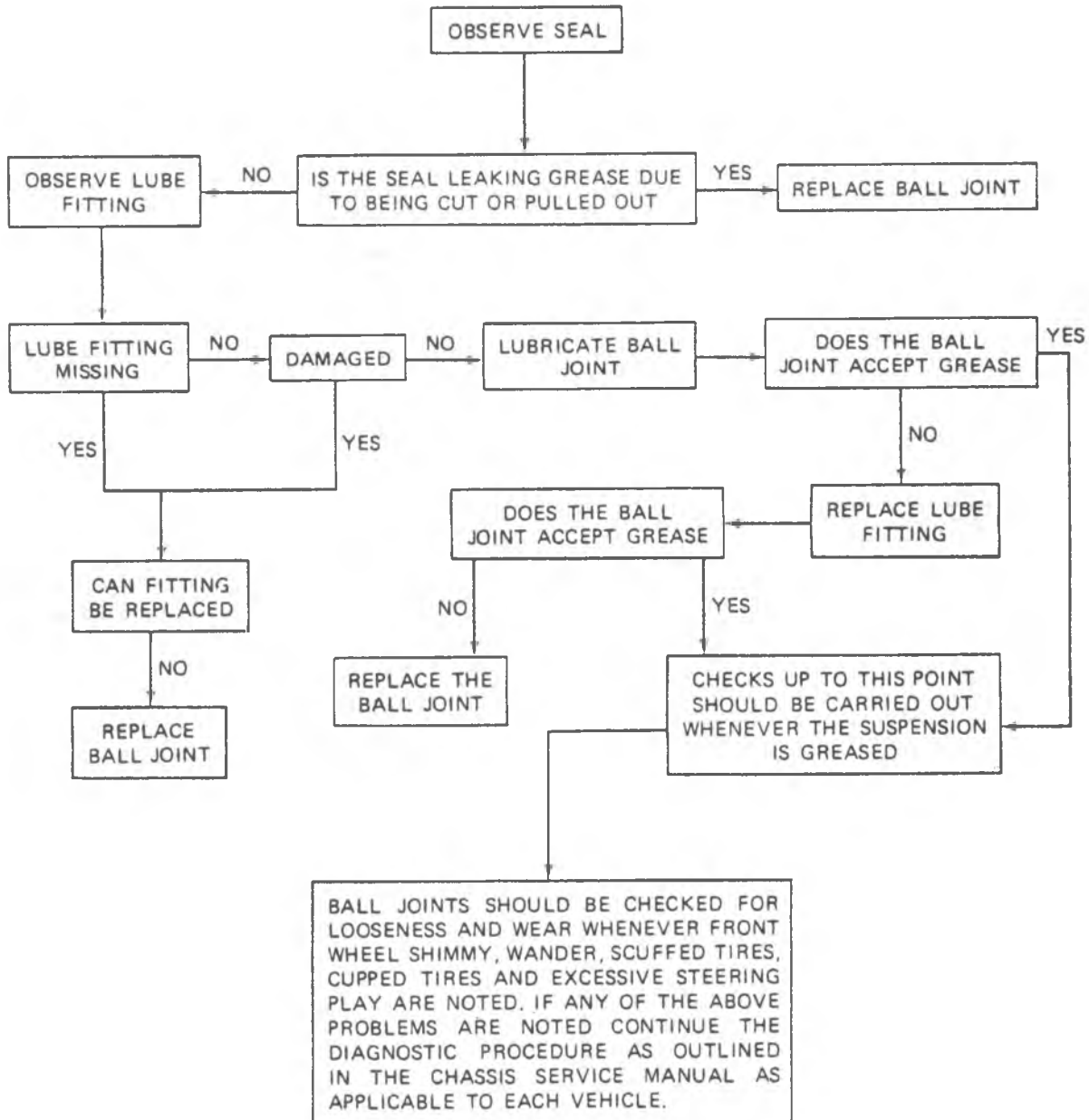

Fig. 3-23--Ball Joint Diagnosis

**BEARINGS AND RACES  
BENCH DIAGNOSTIC PROCEDURE**

This section describes common types of bearing distress and their causes. Illustrations are included to help diagnose the cause of distress and comments are provided to help make effective repairs.

**Consider The Following Factors When Diagnosing Bearing Distress:**

1. Note General Condition of all parts during teardown and examinations.
2. Classify the failure with the aid of these illustrations where possible.
3. Determine the cause. Recognizing the cause will permit correction of the problem and prevent a repeat failure of the same type.
4. Make all repairs following recommended procedures.

**Common Causes For Bearing Distress Include The Following:**

1. Improper adjustment or preloading.
2. Mounting or teardown abuse.
3. Improper mounting methods.
4. Inadequate or wrong lubricants.
5. Entrance of dirt or water.
6. Wear from dirt or metal chips.
7. Corrosion or rusting.
8. Overload.
9. Overheating causing tempering.
10. Fretting of bearing seats.
11. Brinelling from impact loads and shipping.
12. Manufacturing defects.

**FRONT WHEEL, PINION, DIFFERENTIAL SIDE AND REAR WHEEL ROLLER BEARINGS  
DIAGNOSIS**

|                                     | EXCESS NOISE COMPLAINT<br>DIAGNOSTIC PROCEDURE   |
|-------------------------------------|--|
| Road Test                           | <ol style="list-style-type: none"> <li>1. Check tires for irregular wear</li> <li>2. Check tire pressure</li> <li>3. Check lubricant level</li> <li>4. Drive to warm-up rear axle</li> <li>5. Test at various speeds in drive, float, coast and cornering</li> </ol>   |
| Tire Noises                         | <ol style="list-style-type: none"> <li>1. Change tire pressure to minimize noises</li> <li>2. Drive over different road surfaces</li> <li>3. Smooth black-top minimizes tire noise</li> <li>4. Cross switch tires, if necessary</li> <li>5. Snow tire treads and studs caused added noises</li> </ol>  |
| Engine or Exhaust Noises            | <ol style="list-style-type: none"> <li>1. Drive slightly above speed where noise occurs, place transmission in neutral</li> <li>2. Let engine speed drop to idle</li> <li>3. Stop car</li> <li>4. Run engine at various speeds</li> </ol>  |
| Test for Wheel Bearing Noise        | <ol style="list-style-type: none"> <li>1. Drive car at low speed on a smooth road</li> <li>2. Turn car to develop left and right motions, traffic permitting</li> <li>3. Noise should change due to cornering loads</li> <li>4. Jack-up wheels to verify roughness at wheels</li> </ol>  |
| Test for Differential Bearing Noise | <ol style="list-style-type: none"> <li>1. Drive car at low speed on a smooth road</li> <li>2. Constant low pitch bearing noise may be heard</li> <li>3. Noise should not change in reversing turns</li> <li>4. Noise pattern should vary with wheel speed</li> </ol>   |
| Test for Pinion Bearing Noise       | <ol style="list-style-type: none"> <li>1. Roughness or whine noise should increase with speed</li> <li>2. Noise pitch should be higher than differentials</li> <li>3. Test on smooth road to minimize tire noises</li> <li>4. Test at various speeds in drive, float, and coast</li> <li>5. Rear pinion bearing noise may be louder on acceleration</li> <li>6. Front pinion bearing noise may be louder on deceleration</li> <li>7. Gear noises tend to peak in a narrow speed range</li> </ol> |

103407

Fig. 3-24--Bearing Diagnosis Chart A

## FRONT WHEEL BEARING DIAGNOSIS

CONSIDER THE FOLLOWING FACTORS WHEN DIAGNOSING BEARING CONDITION:

1. GENERAL CONDITION OF ALL PARTS DURING DISASSEMBLY AND INSPECTION.
2. CLASSIFY THE FAILURE WITH THE AID OF THE ILLUSTRATIONS.
3. DETERMINE THE CAUSE.
4. MAKE ALL REPAIRS FOLLOWING RECOMMENDED PROCEDURES.

|  |  |   |
|--|--|---|
|  <p style="text-align: center;"><b>GOOD BEARING</b></p>   |  <p style="text-align: center;"><b>BENT CAGE</b></p> <p>CAGE DAMAGE DUE TO IMPROPER HANDLING OR TOOL USAGE.</p> <p>REPLACE BEARING.</p>   |  <p style="text-align: center;"><b>BENT CAGE</b></p> <p>CAGE DAMAGE DUE TO IMPROPER HANDLING OR TOOL USAGE.</p> <p>REPLACE BEARING.</p>  |
|  <p style="text-align: center;"><b>GALLING</b></p> <p>METAL SMEARS ON ROLLER ENDS DUE TO OVERHEAT, LUBRICANT FAILURE OR OVERLOAD.</p> <p>REPLACE BEARING – CHECK SEALS AND CHECK FOR PROPER LUBRICATION.</p> |  <p style="text-align: center;"><b>ABRASIVE STEP WEAR</b></p> <p>PATTERN ON ROLLER ENDS CAUSED BY FINE ABRASIVES.</p> <p>CLEAN ALL PARTS AND HOUSINGS, CHECK SEALS AND BEARINGS AND REPLACE IF LEAKING, ROUGH OR NOISY.</p>                    |  <p style="text-align: center;"><b>ETCHING</b></p> <p>BEARING SURFACES APPEAR GRAY OR GRAYISH BLACK IN COLOR WITH RELATED ETCHING AWAY OF MATERIAL USUALLY AT ROLLER SPACING.</p> <p>REPLACE BEARINGS – CHECK SEALS AND CHECK FOR PROPER LUBRICATION.</p> |
|  <p style="text-align: center;"><b>MISALIGNMENT</b></p> <p>OUTER RACE MISALIGNMENT DUE TO FOREIGN OBJECT.</p> <p>CLEAN RELATED PARTS AND REPLACE BEARING. MAKE SURE RACES ARE PROPERLY SEATED.</p>          |  <p style="text-align: center;"><b>INDENTATIONS</b></p> <p>SURFACE DEPRESSIONS ON RACE AND ROLLERS CAUSED BY HARD PARTICLES OF FOREIGN MATERIAL.</p> <p>CLEAN ALL PARTS AND HOUSINGS, CHECK SEALS AND REPLACE BEARINGS IF ROUGH OR NOISY.</p> |  <p style="text-align: center;"><b>FATIGUE SPALLING</b></p> <p>FLAKING OF SURFACE METAL RESULTING FROM FATIGUE.</p> <p>REPLACE BEARING – CLEAN ALL RELATED PARTS.</p>  |

Fig. 3-25--Bearing Diagnosis Chart B

**FRONT WHEEL BEARING DIAGNOSIS (CONT'D)**

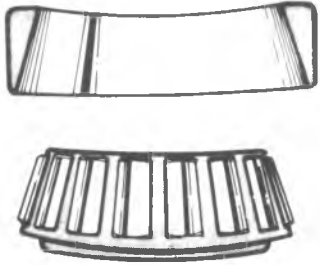
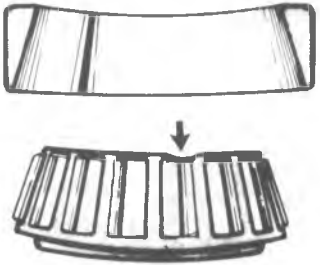
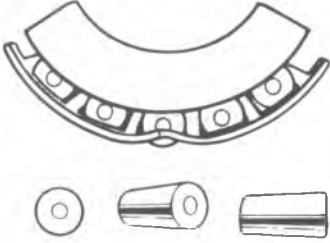
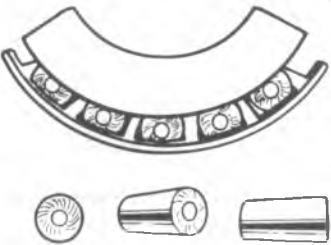
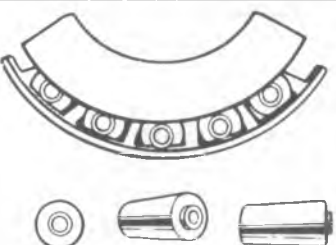
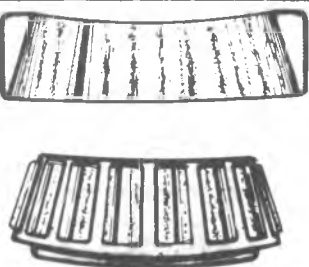
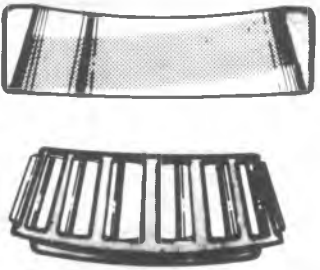
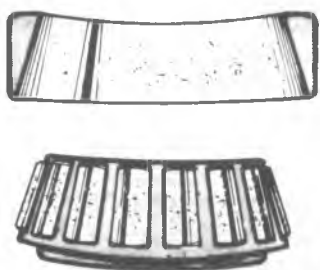
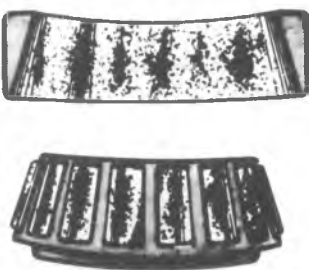

|   |  |  |
|---|--|--|
|  <p><b>BRINELLING</b></p> <p>SURFACE INDENTATIONS IN RACEWAY CAUSED BY ROLLERS EITHER UNDER IMPACT LOADING OR VIBRATION WHILE THE BEARING IS NOT ROTATING.</p> <p>REPLACE BEARING IF ROUGH OR NOISY.</p>   |  <p><b>CAGE WEAR</b></p> <p>WEAR AROUND OUTSIDE DIAMETER OF CAGE AND ROLLER POCKETS CAUSED BY ABRASIVE MATERIAL AND INEFFICIENT LUBRICATION. CHECK SEALS AND REPLACE BEARINGS.</p>   |  <p><b>ABRASIVE ROLLER WEAR</b></p> <p>PATTERN ON RACES AND ROLLERS CAUSED BY FINE ABRASIVES.</p> <p>CLEAN ALL PARTS AND HOUSINGS, CHECK SEALS AND BEARINGS AND REPLACE IF LEAKING, ROUGH OR NOISY.</p> |
|  <p><b>CRACKED INNER RACE</b></p> <p>RACE CRACKED DUE TO IMPROPER FIT, COCKING, OR POOR BEARING SEATS.</p>  |  <p><b>SMEARS</b></p> <p>SMEARING OF METAL DUE TO SLIPPAGE, SLIPPAGE CAN BE CAUSED BY POOR FITS, LUBRICATION, OVERHEATING, OVERLOADS OR HANDLING DAMAGE.</p> <p>REPLACE BEARINGS, CLEAN RELATED PARTS AND CHECK FOR PROPER FIT AND LUBRICATION.</p> <p>REPLACE SHAFT IF DAMAGED.</p>                       |  <p><b>FRETTAGE</b></p> <p>CORROSION SET UP BY SMALL RELATIVE MOVEMENT OF PARTS WITH NO LUBRICATION.</p> <p>REPLACE BEARING. CLEAN RELATED PARTS. CHECK SEALS AND CHECK FOR PROPER LUBRICATION.</p>    |
|  <p><b>HEAT DISCOLORATION</b></p> <p>HEAT DISCOLORATION CAN RANGE FROM FAINT YELLOW TO DARK BLUE RESULTING FROM OVERLOAD OR INCORRECT LUBRICANT.</p> <p>EXCESSIVE HEAT CAN CAUSE SOFTENING OF RACES OR ROLLERS.</p> <p>TO CHECK FOR LOSS OF TEMPER ON RACES OR ROLLERS A SIMPLE FILE TEST MAY BE MADE. A FILE DRAWN OVER A TEMPERED PART WILL GRAB AND CUT METAL, WHEREAS, A FILE DRAWN OVER A HARD PART WILL GLIDE READILY WITH NO METAL CUTTING.</p> <p>REPLACE BEARINGS IF OVER HEATING DAMAGE IS INDICATED. CHECK SEALS AND OTHER PARTS.</p> |  <p><b>STAIN DISCOLORATION</b></p> <p>DISCOLORATION CAN RANGE FROM LIGHT BROWN TO BLACK CAUSED BY INCORRECT LUBRICANT OR MOISTURE.</p> <p>RE-USE BEARINGS IF STAINS CAN BE REMOVED BY LIGHT POLISHING OR IF NO EVIDENCE OF OVERHEATING IS OBSERVED.</p> <p>CHECK SEALS AND RELATED PARTS FOR DAMAGE.</p> |  |

Fig. 3-26--Bearing Diagnosis Chart C



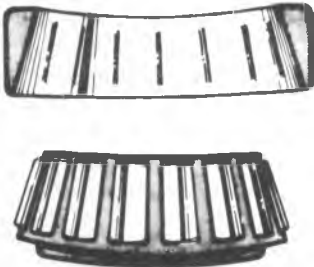
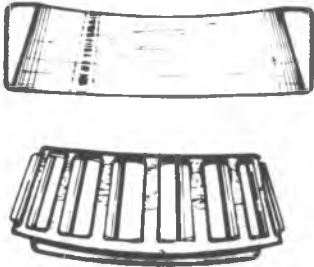
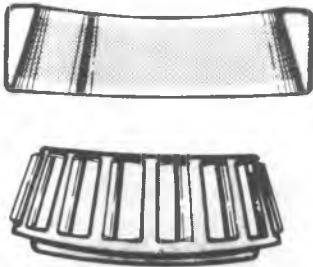
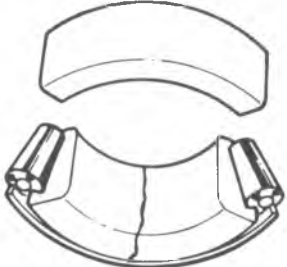
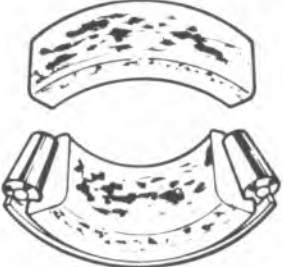
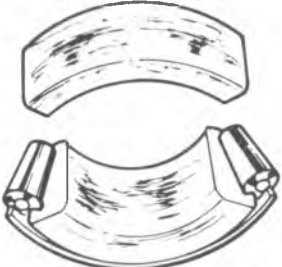

## SECTION 3A

# FRONT ALIGNMENT

### CONTENTS

|                                   |      |
|-----------------------------------|------|
| General Description .....         | 3A-1 |
| Maintenance and Adjustments ..... | 3A-2 |
| Specifications .....              | 3A-5 |

## GENERAL DESCRIPTION

### FRONT ALIGNMENT

The term "front alignment" refers to the angular relationships between the front wheels, the front suspension attaching parts and the ground.

The pointing in or "toe-in" of the front wheels, the tilt of the front wheels from vertical (when viewed from the front of the vehicle) and the tilt of the suspension members from vertical (when viewed from the side of the vehicle), all these are involved in front alignment. The various factors that enter into front alignment are covered here each one under its own heading.

### CASTER

Caster is the tilting of the front steering axis either forward or backward from the vertical (when viewed from the side of the vehicle). A backward tilt is said to be positive (+) and a forward tilt is said to be negative (-).

On the short and long arm type suspension you cannot see a caster angle without a special instrument, but you can understand that if you look straight down from the top of the upper control arm to the ground you would find that the ball joints do not line up (fore and aft) when a caster angle other than 0° is present. If you had a positive caster angle the lower ball joint would be slightly ahead (toward the front of the vehicle) of the upper ball joint center line. In short then, caster is the forward or backward tilt of the steering axis as

viewed from a side elevation. Caster is designed into the front axle assembly on all K series vehicles (four-wheel drive), and is non-adjustable. See caster copy under ADJUSTMENTS.

### CAMBER

Camber is the tilting of the front wheels from the vertical when viewed from the front of the vehicle. When the wheels tilt outward at the top, the camber is said to be positive (+). When the wheels tilt inward at the top, the camber is said to be negative (-). The amount of tilt is measured in degrees from the vertical and this measurement is called the camber angle. Camber is designed into the front axle assembly of all K series vehicles and is non-adjustable. See camber copy under ADJUSTMENTS.

### TOE-IN

Toe-in is the turning in of the front wheels. The actual amount of toe-in is normally only a fraction of an inch. The purpose of a toe specification is to ensure parallel rolling of the front wheels. (Excessive toe-in or toe-out will cause tire wear). Toe-in also serves to offset the small deflections of the wheel support system which occurs when the vehicle is rolling forward. In other words, even when the wheels are set to toe-in slightly when the vehicle is standing still, they tend to roll parallel on the road when the vehicle is moving. See toe-in copy under ADJUSTMENTS.

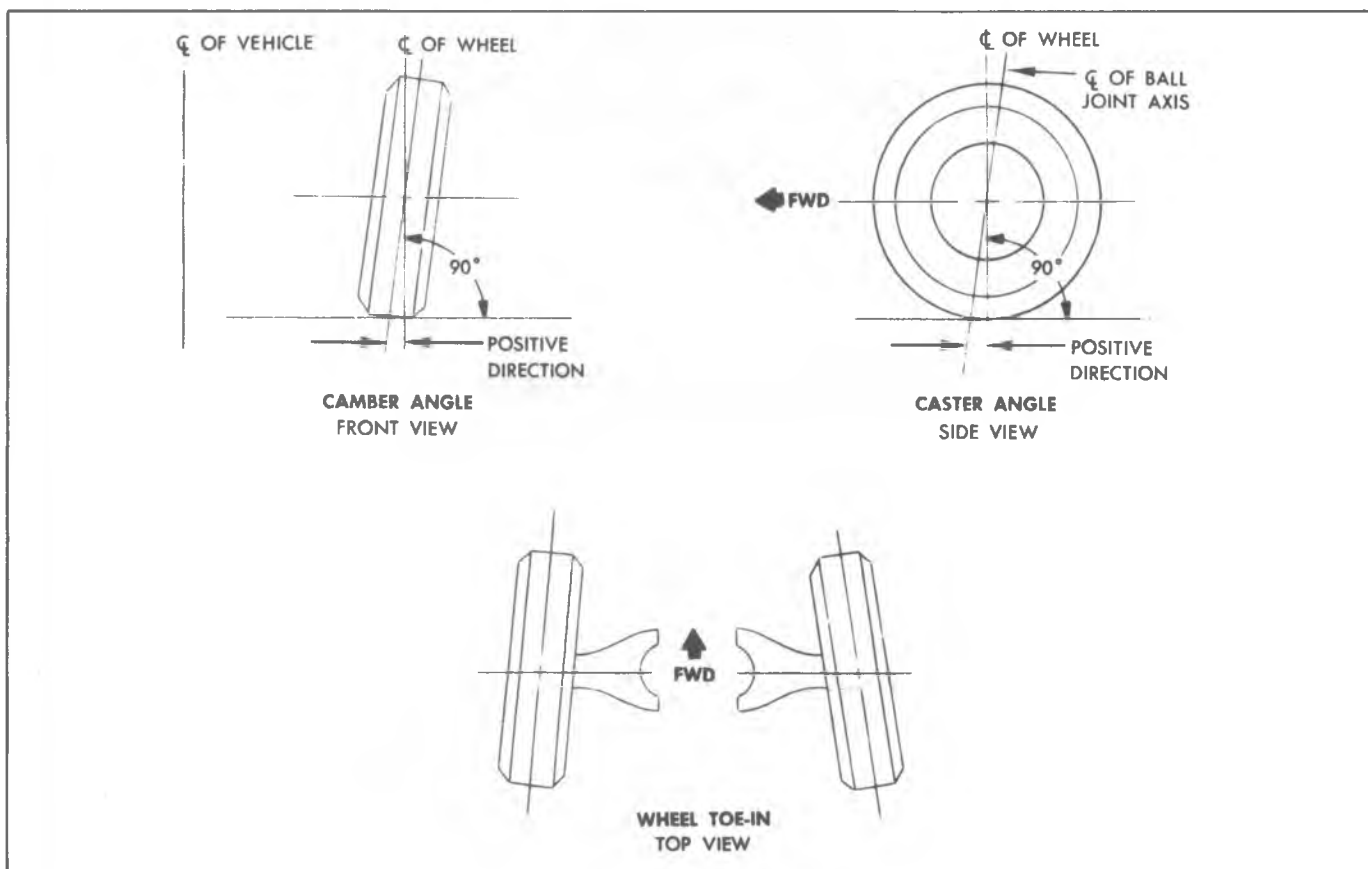

Fig. 3A-1--Caster - Camber - Toe-In

## MAINTENANCE AND ADJUSTMENTS

### PRELIMINARY CHECKS PRIOR TO ADJUSTING FRONT ALIGNMENT

Before making any adjustment affecting caster, camber or toe-in, the following checks and inspections should be made to insure correctness of alignment readings and alignment adjustments.

1. Check all tires for proper inflation pressures and approximately the same tread wear.
2. Check front wheel bearings for looseness (.001-.008 end play is correct) and adjust if necessary.
3. Check for looseness of ball joints, tie rod ends and steering relay rods; if excessive looseness is noted, it must be corrected before adjusting.
4. Check for run-out of wheels and tires.
5. Check dimension A in Fig. 3A-4; if out of specifications and a correction is to be made, the correction must be made before adjusting caster.
6. Check for steering gear looseness at frame.
7. Check for improperly operating shock absorbers.
8. Check for loose control arms.
9. Check for loose or missing stabilizer bar attachments.
10. Consideration must be given to excess loads, such as tool boxes. If this excess load is **normally** carried in the vehicle, it should remain in the vehicle during alignment checks.

11. Consider the condition of the equipment being used to check alignment and follow the manufacturer's instructions.
12. Regardless of equipment used to check alignment, the vehicle must be on a level surface both fore and aft and transversely.
13. Steering and vibration complaints are not always the result of improper alignment. An additional item to be checked is the possibility of tire lead due to worn or improperly manufactured tires. "Lead" is the deviation of the vehicle from a straight path on a level road without hand pressure on the steering wheel. Section 3E of this manual, "Wheels and Tires", contains a procedure for determining the presence of a tire lead problem.

### FRONT ALIGNMENT REQUIREMENTS

Satisfactory vehicle operation may occur over a wide range of front end wheel alignment settings. Nevertheless, should settings vary beyond certain tolerances, readjustments of alignment is advisable. The specifications stated in column 1 of the chart in the specifications section of this manual should be used by owners, dealers and repairmen as guidelines in vehicle diagnosis either for repairs under the new vehicle warranty or for maintenance service at customer's request. These specifications provide an acceptable all-around operating range in that they prevent abnormal tire wear caused by wheel alignment.

Governmental Periodic Motor Vehicle Inspection programs usually include wheel alignment among items that are inspected. To provide useful information for such inspections, the specifications stated in column 2 of the wheel alignment chart are given and these are well within the range of safe vehicle operation.

In the event the actual settings are beyond the specifications set forth in column 1 or 2 (whichever is applicable), or whenever for other reasons the alignment is being reset, the specifications given in column 3 of the wheel alignment chart should be used.

It is good practice to set front end alignment to specifications while the vehicle is in its **normally loaded** condition. Trucks which are **consistently operated with heavy loads should have toe-in adjusted with the truck under heavy load**. This procedure should result in longer tire life.

## ALIGNMENT ADJUSTMENTS

A normal shim pack will leave at least two (2) threads of the bolt exposed beyond the nut. If two (2) threads cannot be obtained, check for damaged control arms and related parts. The difference between front and rear shim packs must not exceed 7.62mm (.30 inches). Front shim pack must be at least 2.54mm (.10 inches).

### Access to Shim Packs

#### G10-20 Models, C10 Models with 3/4" Nut:

With vehicle on front end rack, jack at frame and raise the wheel off the ground. This will allow the upper control arm to pivot down far enough to use a socket on the nuts and permit shim removal.

#### G30 Models, C20 and 30 Models with 7/8" Nut:

Remove the upper control arm bumper; then follow the same procedure as above. Reinstall the upper control arm bumper when alignment is completed.

## Caster

All caster specifications are given assuming a frame angle of zero. Therefore, it will be necessary to know the angle of the frame (whether "up" in rear or "down" in rear) before a corrected caster reading can be determined. Camber and toe can be read "as is" from the alignment equipment.

### How to Determine Caster (Fig. 3A-4)

All caster specifications are given assuming vehicle frame angle is zero. Therefore, it is necessary to adjust specifications when applying them to vehicles with any frame angle other than zero.

1. With vehicle on a level surface, determine frame angle (whether up or down in rear) with the use of a bubble protractor or inclinometer. Record this measurement (See Figure 4).
2. Measure dimension "A" (See Figure 4).
3. Check and record specifications for caster under that column related to dimension "A" as measured in step 2.
4. Using one of the following rules, add or subtract frame angle found in step 1 to or from specification found in step 3.
  - a. A down-in-rear frame angle must be added to a positive caster specification.
  - b. An up-in-rear frame angle must be subtracted from a positive caster specification.
  - c. A down-in-rear frame angle must be subtracted from a negative caster specification.
  - d. An up-in-rear frame angle must be added to a negative caster specification.

Vehicle caster specification should be adjusted to answer arrived at in step 4.

## Camber

1. Determine the camber angle from the alignment equipment.
2. Add or subtract shims from both the front and rear bolts to affect a change.

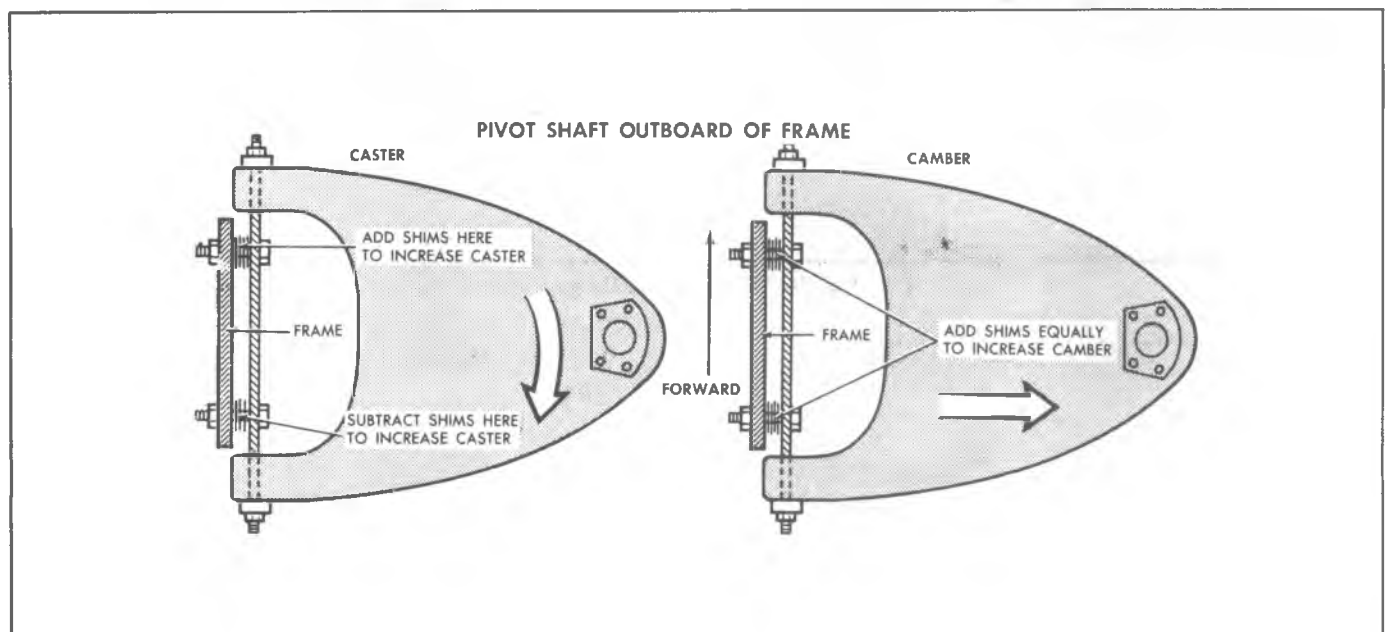

Fig. 3A-2--Caster - Camber Adjustment

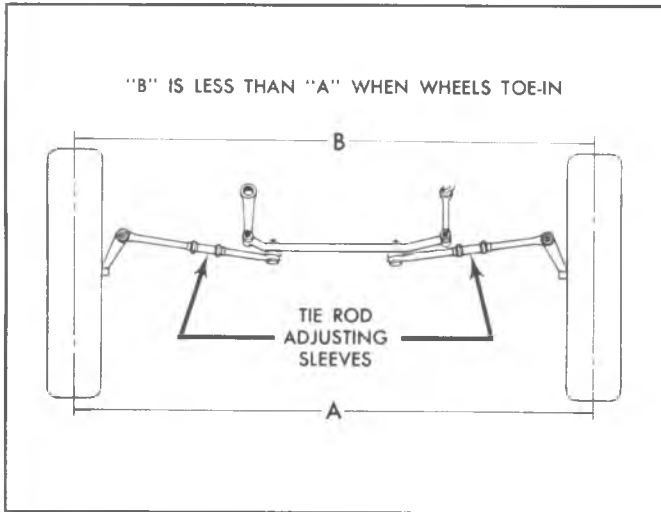

Fig. 3A-3--Toe-In Adjustment

### Toe-In

1. Determine the wheel toe-in from the alignment equipment.
2. Change the length of both tie rod sleeves to affect a toe change.

Toe-in can be increased or decreased by changing the length of the tie rods. A threaded sleeve is provided for this purpose.

When the tie rods are mounted ahead of the steering knuckle they must be decreased in length in order to increase toe-in. When the tie rods are mounted behind the steering knuckle they must be lengthened in order to increase toe-in.

See Section 3B for proper tie rod clamp orientation and positioning.

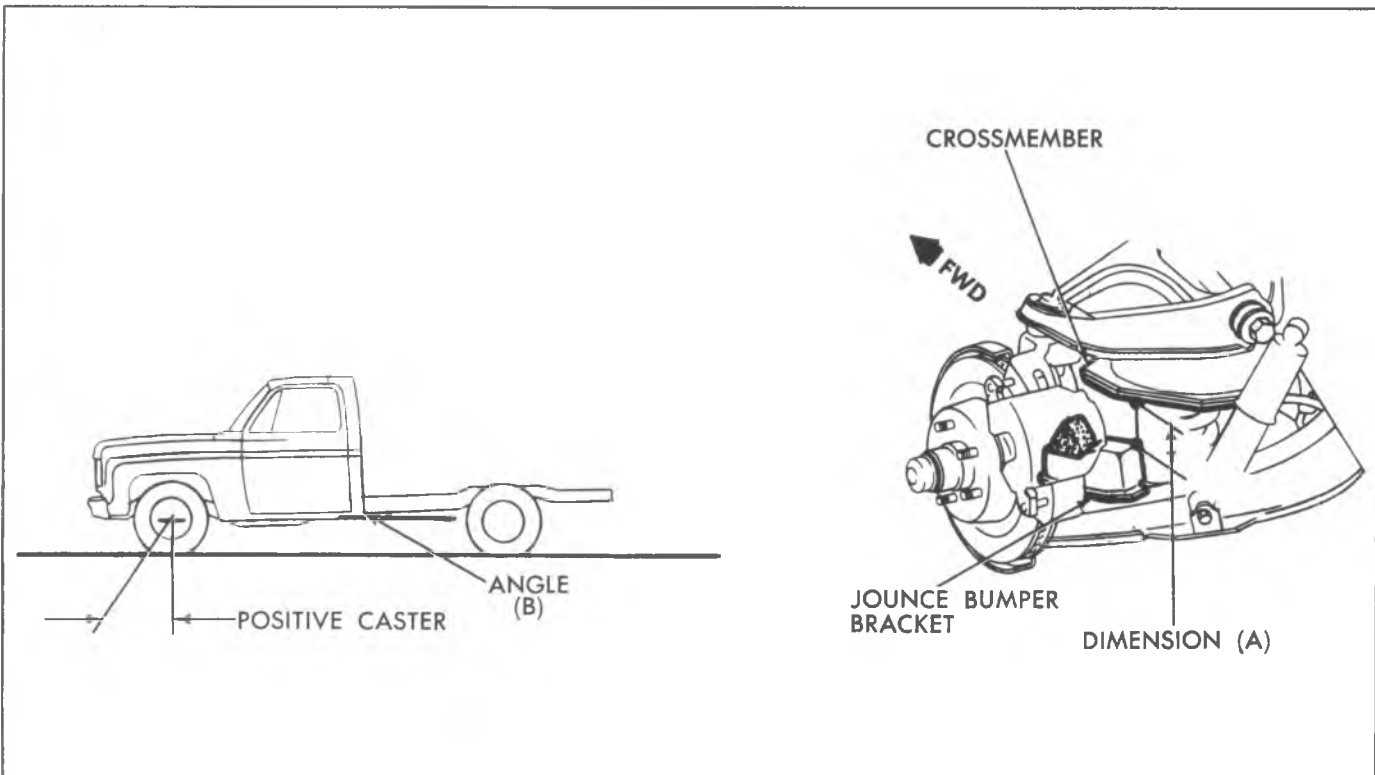

Fig. 3A-4--Determining Caster

# SPECIFICATIONS

## WHEEL ALIGNMENT SPECIFICATIONS CASTER

### DIMENSION "A"

|  |                                |      |      |      |      |      |       |       |       |       |       |       |
|--|--------------------------------|------|------|------|------|------|-------|-------|-------|-------|-------|-------|
| <b>MODELS</b><br>(mm)                              | 2½"                            | 2¾"  | 3"   | 3¼"  | 3½"  | 3¾"  | 4"    | 4¼"   | 4½"   | 4¾"   | 5"    |       |
|  | 63.5                           | 69.8 | 76.2 | 82.5 | 89.0 | 95.2 | 102.0 | 107.9 | 114.3 | 121.6 | 127.0 |       |
| <b>C10</b>   | 3.6°                           | 3.4° | 3.1° | 2.8° | 2.6° | 2.4° | 2.0°  | 1.8°  | 1.5°  | 1.2°  | 1.0°  |       |
| <b>C20, 30</b>                                     | 1.5°                           | 1.2° | 0.9° | 0.6° | 0.3  | 0.1° | 0°    | -0.1° | 0.7   | -1.0  | 1.2°  |       |
| <b>K10,20,30</b>                                   | (8°) (NO ADJUSTMENT PROVISION) |      |      |      |      |      |       |       |       |       |       |       |
| (mm)   | 1½"                            | 1¾"  | 2"   | 2¼"  | 2½"  | 2¾"  | 3"    | 3¼"   | 3½"   | 3¾"   | 4"    | 4¼"   |
|  | 38.0                           | 44.4 | 51.0 | 57.1 | 63.5 | 69.8 | 76.2  | 82.5  | 89.0  | 95.2  | 102.0 | 107.9 |
| <b>G10, 20</b>                                     | 3.5                            | 3.3  | 3.1  | 2.9  | 2.7  |      | 2.4   | 2.2   | 2.1   | 1.9   | 1.8   | 1.6   |
| <b>G30</b>   | 2.8                            | 2.5  | 2.2  | 1.9  | 1.6  |      | 1.0   | 7     | 5     | 2     | 0     | -0.2  |
| (mm)   | 2½"                            | 2¾"  | 3"   | 3¼"  | 3½"  | 3¾"  | 4"    | 4¼"   | 4½"   | 4¾"   | 5"    |       |
|  | 63.5                           | 69.8 | 76.2 | 82.5 | 89.6 | 95.2 | 102.0 | 107.9 | 114.3 | 120.6 | 127.0 |       |
| <b>P10</b>   | 2.3°                           | 2.0° | 1.7° | 1.5° | 1.2° | 0.9° | 0.6°  | 0.4°  | 0.1°  | -0.1° | -0.3° |       |
| (mm)   | 2"                             | 2¼"  | 2½"  | 2¾"  | 3"   | 3¼"  | 3½"   | 3¾"   | 4"    | 4¼"   | 4½"   | 4¾"   |
|  | 51.0                           | 57.1 | 63.5 | 69.8 | 76.2 | 82.5 | 89.0  | 95.2  | 102.0 | 107.9 | 114.3 | 120.6 |
| <b>*P20, 30</b>                                    | 2.9°                           | 2.6° | 2.3° | 2.0° | 1.7° | 1.4° | 1.2°  | 0.9°  | 0.6   | 0.4°  | 0.2°  | 0.1°  |
| * ADD .3° WITH JB8 OR JF9<br>SUBTRACT .4° WITH R05 |                                |      |      |      |      |      |       |       |       |       |       |       |
| <b>MOTOR HOME (32)</b><br>(mm)                     | 2½"                            | 2¾"  | 3"   | 3¼"  | 3½"  | 3¾"  | 4"    | 4¼"   | 4½"   | 4¾"   | 5"    |       |
|  | 63.5                           | 69.8 | 76.2 | 82.5 | 89.0 | 95.2 | 102.0 | 107.9 | 114.3 | 120.6 | 127.0 |       |
|  | 5.5°                           | 5.3° | 5.0° | 4.7° | 4.4° | 4.1° | 3.8°  | 3.6°  | 3.3°  | 3.1°  | 2.9°  |       |

| CAMBER          |                                |
|-----------------|--------------------------------|
| MODEL           |                                |
| C10             | .7°                            |
| C20,30          | 2°                             |
| K10, 20         | 1.0° (NO ADJUSTMENT PROVISION) |
| K30             | 5° (NO ADJUSTMENT PROVISION)   |
| G10, 20         | 5°                             |
| G30             | 2°                             |
| P10, 20, 30     | 2°                             |
| MOTOR HOME (32) | 2°                             |

| ALIGNMENT TOLERANCES |                          |                  |                                   |
|----------------------|--------------------------|------------------|-----------------------------------|
|                      | Warranty Repair Checking | Resetting Target | Periodic Motor Vehicle Inspection |
| Caster               | + 1°                     | + 0.5°           | + 2°                              |
| Camber               | ± 0.7°                   | ± 0.5°           | ± 1.5°                            |
| Toe-In               | ± 1/8" (3.2 mm)          | ± 1/16" (1.6 mm) | ± 3/8" (9.5 mm)                   |

| TOE-IN              |                |
|---------------------|----------------|
| C10, C20, C30       | 3/16" (4.7 mm) |
| K10, K20, K30       | 3/16" (4.7 mm) |
| G10, G20, G30       | 3/16" (4.7 mm) |
| P10, P20, P30       | 3/16" (4.7 mm) |
| MOTOR HOME P30 (32) | 5/16" (7.9 mm) |



## SECTION 3B1

# STEERING LINKAGE

The following notice applies to one or more steps in the assembly procedure of components in this portion of the manual as indicated at appropriate locations by the terminology "See Notice on page 1 of this Section".

**NOTICE:** These fasteners are important attaching parts in that they could affect the performance of vital components and systems, and/or could result in major repair expense. They must be replaced with one of the same part number or with an equivalent part if replacement becomes necessary. Do not use a replacement part of lesser quality or substitute design. Torque values must be used as specified during reassembly to assure proper retention of these parts. For prevailing torque nut(s) and bolt(s), refer to the "Reuse of Prevailing Torque Nut(s) and Bolt(s)" chart in Section 10.

### CONTENTS

|                                   |       |
|-----------------------------------|-------|
| General Description.....          | 3B1-1 |
| Maintenance and Adjustments ..... | 3B1-2 |
| On-Vehicle Service .....          | 3B1-2 |
| Tie Rods.....                     | 3B1-2 |
| Relay Rod .....                   | 3B1-5 |
| Idler Arm.....                    | 3B1-6 |
| Pitman Arm.....                   | 3B1-6 |
| Steering Connecting Rod .....     | 3B1-7 |

### GENERAL DESCRIPTION

The steering linkage is located forward of the front crossmember. Refer to Fig. 3B1-1, for a typical system. Steering effort is transmitted to left and right hand adjustable tie rods through a relay rod. The relay rod is connected to an idler arm on the right and to the pitman arm on the left.

### DIAGNOSIS

Reference should be made to the correct method of disassembly, repair, adjustment and reassembly. Damaged, broken or deformed parts must be replaced with the correct replacement. See Section 3.

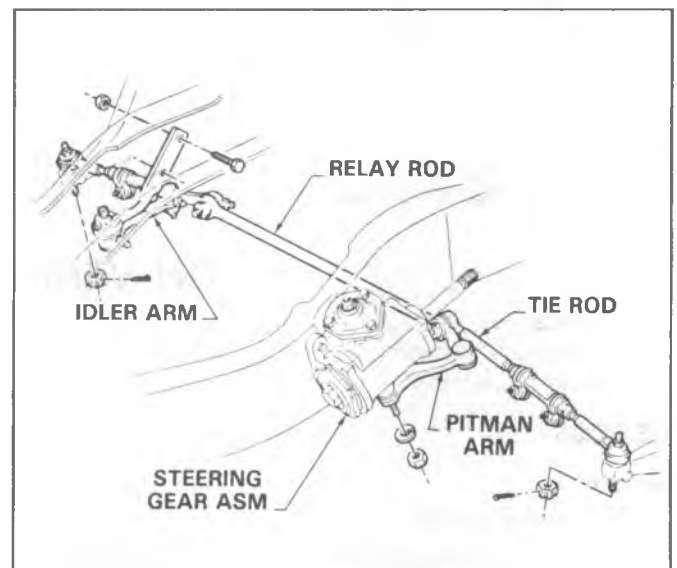

Fig. 3B1-1--Typical Steering Linkage

## MAINTENANCE AND ADJUSTMENTS

### LUBRICATION

#### LUBRICATION OF STEERING LINKAGE

The steering linkage under normal conditions should be lubricated with any water resistant EP type chassis lubricant every 7,500 miles (12 000 km) or six months,

whichever occurs first. Lubricate every 3,000 miles (4 800 km) or two months whichever occurs first when operating in dusty or muddy conditions or if the vehicle is used "off-road". Lubrication points and additional information on the chassis lubricant recommended can be found in Section 0--General Information and Lubrication.

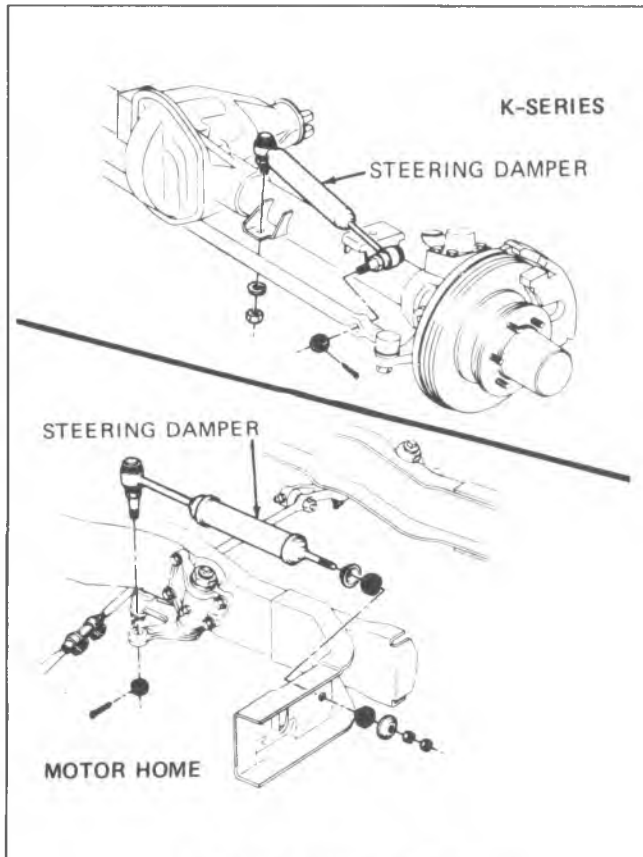

Fig. 3B1-2--Steering Dampers

### STEERING DAMPER CHECK

(Fig. 3B1-2)

This type of steering damper is nonadjustable, nonrefillable and is not repairable. At each lubrication interval make check #1 and #2 on the steering damper system.

1. **Inspecting Damper Mountings:** Check the damper attachments to be sure they are properly and securely installed. (Tighten, if loose). Replace the damper assembly if the rubber bushings are badly worn.
2. **Inspecting Damper For Leaks:** Inspect the damper for evidence of fluid leakage. A light film of fluid is permissible on the body of the damper near the shaft seal. A dripping damper should be replaced.

If a Functional or Noise Complaint is Reported, Make the Following Inspections:

3. **Inspecting Damper For Noise:** Disconnect the frame or axle end of the damper. Extend and compress the damper using as much travel as possible. The damper action should be smooth throughout each stroke.
4. **Inspecting Damper For Functioning:** While checking the damper in step (3) above, observe the operation of the damper for fluid leakage, effort and lag. Items from this check that require damper replacement are:
  - a. Any fluid leakage during this check.
  - b. Seizing or binding condition during travel of damper.
  - c. A skip or lag at reversal near mid-stroke of damper.
5. **Reinstall Disconnected End of Damper Using Proper Torque.**

## ON-VEHICLE SERVICE

**NOTICE:** See NOTICE on page 1 of this section regarding all fasteners referred to in servicing steering linkage components.

### TIE RODS

#### Removal

1. Raise vehicle on hoist.
2. Remove nuts from ball studs. The inner tie rod ends use crimp nuts, while the outer ends use castellated nuts and cotter pins.
3. To remove outer ball stud, tap on steering arm at tie rod end with a hammer while using a heavy hammer or similar tool as a backing.
4. Remove inner ball stud from relay rod using same procedure as described in Step 3.
5. To remove tie rod ends from tie rod, loosen clamp bolts and unscrew end assemblies.

#### Installation

**NOTICE:** See the NOTICE on page 1 of this section regarding the fasteners referred to in steps 4 and 6.

Tie rod adjuster components often become rusted in service. In such cases, it is recommended that if the torque required to remove the nut from the bolt after breakaway exceed 7 pounds, discard the nuts and bolts. Apply penetrating oil between the clamp and tube and rotate the clamps until they move freely. Install new bolts and nuts having the same part number to assure proper clamping at the specified nut torque.

As a guide to correct orientation of the inner tie rod end relative to the outer tie rod end, rotate both ends to the extremes of travel in the same direction before clamping. The position of each tie rod end must be maintained as the clamps are tightened to ensure free movement of each joint. Return the rod assembly to midposition of its travel. This should result in the inner and outer ball studs being retained in a parallel relationship with the intermediate (relay) rod and steering knuckle (arm) respectively. The following procedure should be used when installing tie rods.

1. If the tie rod ends were removed, lubricate the tie rod threads with EP Chassis lube and install ends on tie rod making sure both ends are threaded an equal distance from the tie rod.



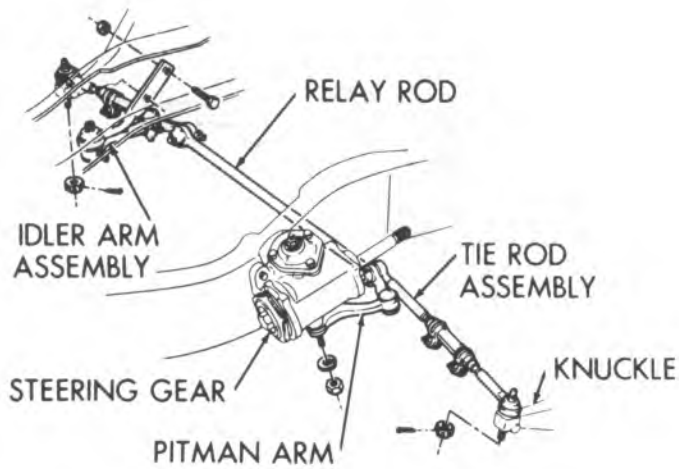

**C-SERIES**

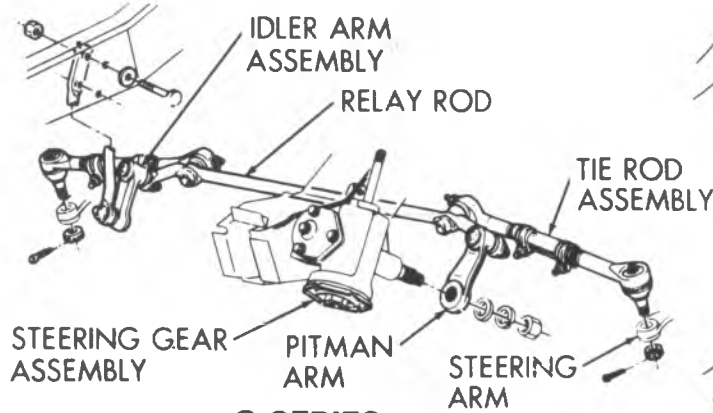

**G-SERIES**

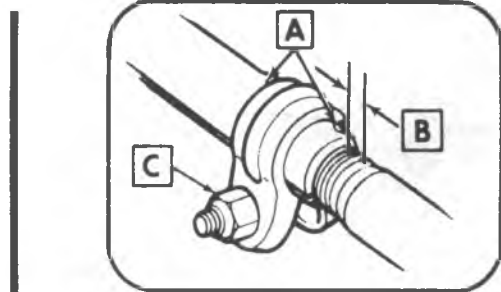

- A** **CAUTION** All clamps must be between & clear of dimples before torquing nut.
- B** Exposed socket thread length must be equal within  $\pm .06$  at each end of adjusting sleeve on L.H. & R.H. tie rod asm.
- C** All bolts must be installed in directions shown -

ADJUSTABLE CONNECTING ROD

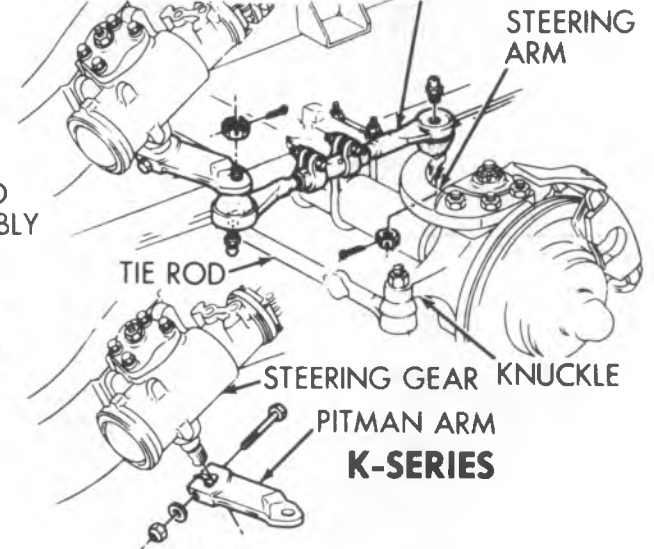

**K-SERIES**

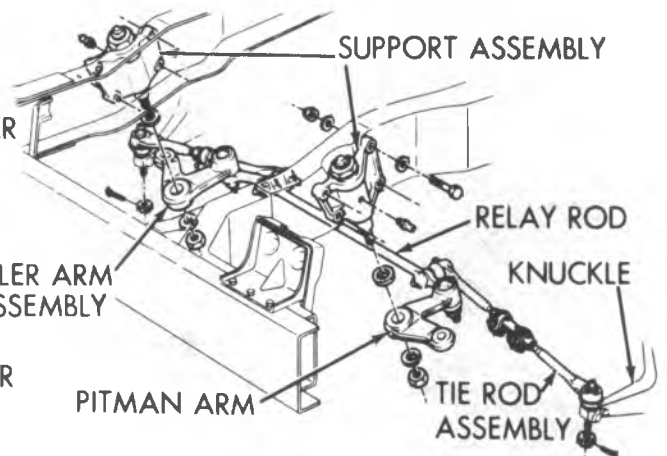
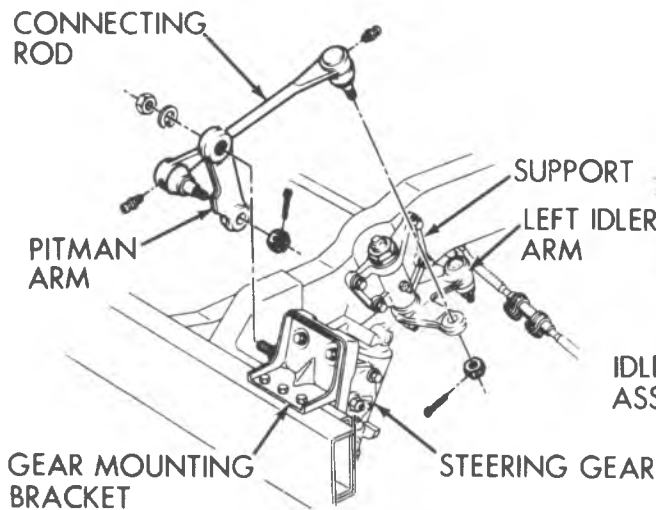

**P-SERIES**

Fig. 3B1-3--Steering Linkage

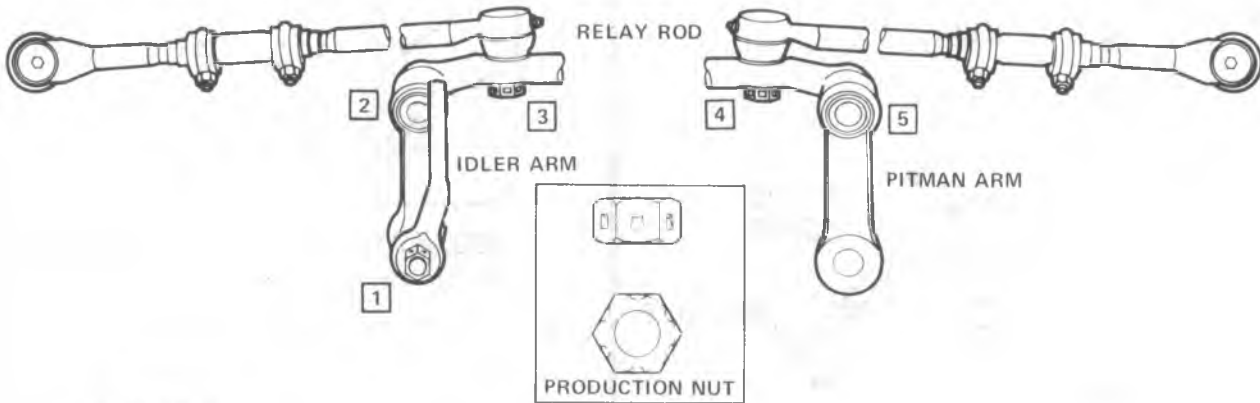

**IMPORTANT**

WHENEVER ANY OF THE CRIMP NUTS OR STUDS AT THE (5) LOCATIONS SHOWN ARE LOOSENED OR REMOVED, THE FOLLOWING STEPS MUST BE TAKEN:

- A. WHEN RE-ATTACHING ANY TWO COMPONENTS BY MEANS OF A BALL STUD, CAREFULLY POSITION THE TWO PARTS. THEN INSTALL A FREE-SPINNING NUT, AND DRAW THE ITEMS TOGETHER TO SEAT THE TAPER, TORQUE NUT TO 54 N·m (40 FT-LBS), THEN REMOVE NUT.
- B. THEN USE A TORQUE PREVAILING SERVICE REPLACEMENT NUT (#351249) AND TORQUE TO 90 N·m (66 FT-LBS).

Fig. 3B1-4--Typical Crimp Nut Locations

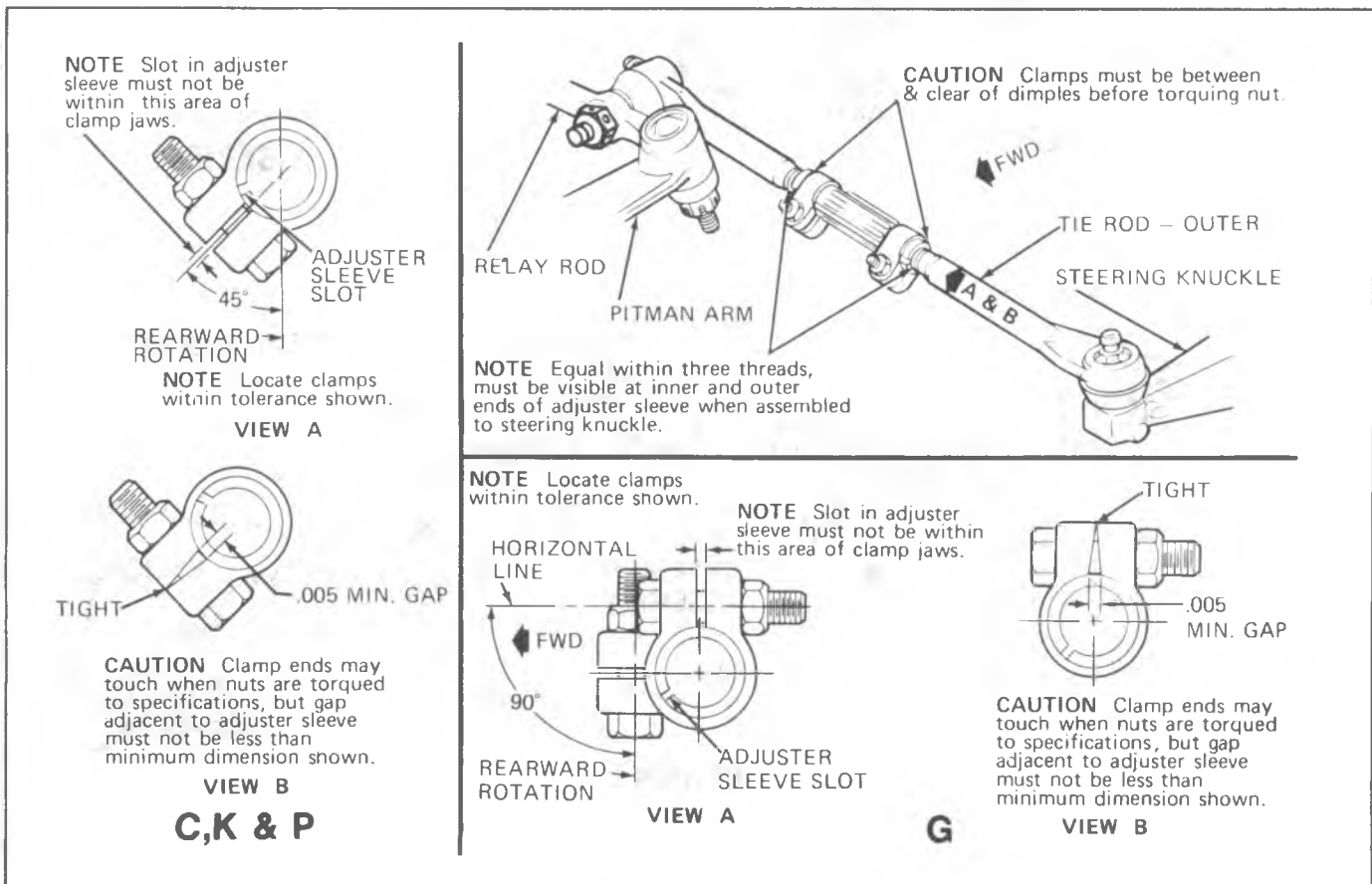

Fig. 3B1-5--Tie Rod Clamp Relationship

2. Make sure that threads on ball studs and in ball stud nuts are clean and smooth. If threads are not clean and smooth, ball studs may turn in tie rod ends when attempting to tighten nut. Check condition of ball stud seals; replace if necessary. Tool J-24434 may be used to install ball stud seals.
3. Install ball studs in steering arms and relay rod. For the inner tie rod ends, use J-29193 or J-29194 to seat the tapers, as shown in Fig. 3B1-4. A torque of 20 N·m is required. With the tapers seated, remove the tool.
4. For the inner tie rod ends, install a torque prevailing ball stud nut, and tighten to 54 N·m (40 ft. lbs.). At the outer tie rod ends, install a ball stud nut, tighten to 70 N·m (50 lb. ft.), and install new cotter pins. Lubricate tie rod ends.
5. Adjust toe-in as described in Section 3A.

Before tightening the tie rod adjusting sleeve clamp bolts, be sure that the following conditions have been met:

- a. The sleeve clamps must be positioned between the locating dimples at either end of the sleeve.
- b. The clamps must be positioned within the angular travel indicated in Figure 3B1-5.
- c. The relationship of the clamp slot with the slit in the sleeve should be maintained as shown in Figure 3B1-4.
- d. Rotate both inner and outer tie rod housing rearward to the limit of ball joint travel before tightening clamps. Tighten clamps to 22 N·m, 16 ft. lbs. Return tie rod assembly to the center of travel.
- e. All procedures for alignment, adjustment and assembly of tie rods applies to each side.
- f. Check each assembly to be sure that a total travel of at least 35° can be obtained using a bubble protractor and a pair of vise grips.

### Inspection

To ensure proper installation, it is necessary to perform the following inspection after any change of toe setting or removal of any ball stud:

1. Check the total rotation of the tie rod assembly using the following procedure:
  - a. Lubricate inner and outer tie rod ends.
  - b. Attach vise grip pliers to the outer tie rod end.
  - c. Rotate outer tie rod end counterclockwise (up) to maximum position. Attach bevel protractor. Center protractor bubble indicator and record reading.
  - d. Rotate tie rod end clockwise (down) to maximum position. Center protractor bubble indicator and record reading.
  - e. Compare protractor readings obtained in Steps c and d. Total rotation of tie rod assembly should measure at least 35°.
  - f. If rotation is less than 35°, loosen one tie rod sleeve clamp and rotate both tie rod ends to their maximum limit **both ends must be rotated in the same direction.**
  - g. Tighten tie rod clamp and again rotate both ends to their maximum limits, repeating Steps c and d. This recheck of total rotation will result in a minimum of 35° travel.
  - h. After obtaining the correct amount of rotation (35° or greater), position the outer tie rod end approximately midway in this travel.

If rotating checks, outlined above, reveal a rough or lumpy feel, the inner or outer tie rod end assembly may have excessive wear and should be replaced.

If all of the above mentioned conditions are met, proper tie rod installation is assured.

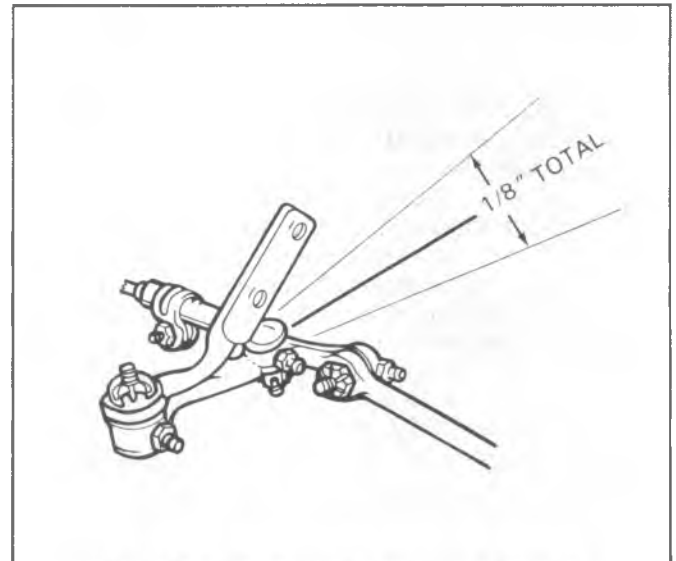

Fig. 3B1-6--Checking Idler Movement, Typical

### RELAY ROD

#### Removal

1. Raise vehicle on hoist.
2. Remove inner ends of the tie rods from relay rod as described under "Tie Rod-Removal".
3. Remove the nuts from the pitman and idler arm ball studs at the relay rod.
4. Remove the relay rod from the pitman and idler arms by tapping on the relay rod ball stud bosses with a hammer, while using a heavy hammer as a backing (Fig. 3B1-4).
5. Remove the relay rod from the vehicle.

#### Installation

**NOTICE:** See the NOTICE on page 1 of this section regarding the fasteners referred to in steps 2 and 3.

1. Make sure that threads on the ball studs and in the ball stud nuts are clean and smooth. If threads are not clean and smooth, ball studs may turn in sockets when attempting to tighten nut. Check condition of ball stud seals; replace if necessary.
2. Install the relay rod to the idler arm and pitman arm ball studs, making certain the seals are in place. Use a free-spinning nut to seat the tapers, as shown in Fig. 3B1-4.
3. Install the tie rods to the relay rod as previously described under "Tie Rod- Installation". Lubricate the tie rod ends.
4. Lower the vehicle to the floor.
5. Adjust toe-in (see Section 3A) and align steering wheel as described previously in Section 3B4 under "Steering Wheel Alignment and High Point Centering".

**IDLER ARM (EXCEPT P SERIES MOTORHOME)**

Use of the proper diagnosis and checking procedure is essential to prevent needless replacement of good idler arms.

1. Raise the vehicle in such a manner as to allow the front wheels to rotate freely and the steering mechanism freedom to turn. Position the wheels in a straight ahead position.
2. Using a spring scale located as near the relay rod end of the idler arm as possible, exert a 25 lb. force upward and then downward while noticing the total distance the end of the arm moves. This distance should not exceed  $\pm 1/16$  inch for a total acceptable movement of  $1/8$  inch (Figure 3B1-6). It is necessary to ensure that the correct load is applied to the arm since it will move more when higher loads are applied. It is also necessary that a scale or ruler be rested against the frame and used to determine the amount of movement since observers tend to over-estimate the actual movement when a scale is not used. The idler arm should always be replaced if it fails this test.

Jerking the right front wheel and tire assembly back and forth, thus causing an up and down movement in the idler arm is not an acceptable method of checking since there is no control on the amount of force being applied.

Caution should be used in assuming shimmy complaints are caused by loose idler arms. Before suspecting suspension or steering components, technicians should eliminate shimmy excitation factors, such as dynamic imbalance, run-out or force variation of wheel and tire assemblies and road surface irregularities.

**Removal**

1. Raise vehicle on a hoist.
2. Remove the nut from ball stud at the relay rod. Remove the ball stud from the relay rod by tapping on the relay rod boss with a hammer, while using a heavy hammer as a backing.
3. Remove the idler arm to frame bolt and remove the idler arm assembly.

**Installation**

**NOTICE:** See the NOTICE on page 1 of this section regarding the fasteners referred to in steps 1 and 3.

1. Position the idler arm on the frame and install the mounting bolts (special plain washers under bolt heads); torque the nuts to 40 N·m, 30 ft. lbs.
2. Make sure that the threads on the ball stud and in the ball stud nut are clean and smooth. If threads are not clean and smooth, ball stud may turn in the socket when attempting to tighten nut. Check condition of ball stud seal; replace if necessary.
3. Install the idler arm ball stud in the relay rod, making certain the seal is positioned properly. Use a 5/8-18 free-spinning nut to seat the tapers, as shown in Fig. 3B1-4.
4. Lower the vehicle to the floor.

**IDLER ARM--P SERIES MOTORHOME**

The frame mounted idler support assembly is adjustable for support shaft end play. Check for idler arm movement at the relay rod end as indicated above. If the movement at the end of the arm exceeds  $\pm 1/16$  inch ( $1/8$  inch total movement), readjust the support shaft end-play as follows:

1. Loosen the support assembly jam nut.
2. Tighten the adjusting plug to metal-to-metal contact.
3. Back off the adjusting plug  $1/8$  of a turn ( $1/2$  of a flat on the square nut, or  $45^\circ$ ).
4. Retorque the jam nut to 25-35 ft. lbs., while taking care that the adjusting plug does not rotate.

**PITMAN ARM****Removal**

1. Raise vehicle on hoist.
2. Remove nut from pitman arm ball stud.
3. Remove pitman arm or relay rod from ball stud by tapping on side of rod or arm (in which the stud mounts) with a hammer while using a heavy hammer or similar tool as a backing. Pull on linkage to remove from stud.
4. Remove pitman arm nut from pitman shaft or clamp bolt from pitman arm, and mark relation of arm position to shaft.
5. Remove pitman arm, using Tool J-6632 or J-5504.

**Installation**

**NOTICE:** See the NOTICE on page 1 of this section regarding the fasteners referred to in steps 3 and 4.

1. Install pitman arm on pitman shaft, lining up the marks made upon removal.

**NOTICE:** If a clamp type pitman arm is used, spread the pitman arm just enough, with a wedge, to slip arm onto pitman shaft. Do not spread pitman arm more than required to slip over pitman shaft with hand pressure. Do not hammer or damage to steering gear may result. Be sure to install the hardened steel washer before installing the nut.

2. Make sure that threads on ball studs and in ball stud nuts are clean and smooth. If threads are not clean and smooth, ball studs may turn in sockets when attempting to tighten nut. Check condition of ball stud seals; replace if necessary.
3. Install pitman shaft nut or pitman arm clamp bolt and torque to specifications; (C, G Series - 260 N·m (192 ft. lbs.), K Series - 125 N·m (92 ft. lbs.), P Series - 180 N·m (132 ft. lbs.).
4. Position ball stud onto pitman arm or relay rod. Use a 5/8-18 free spinning nut to seat the tapers, as shown in Fig. 3B1-4.
5. Lubricate ball studs.
6. Lower the vehicle to the floor.

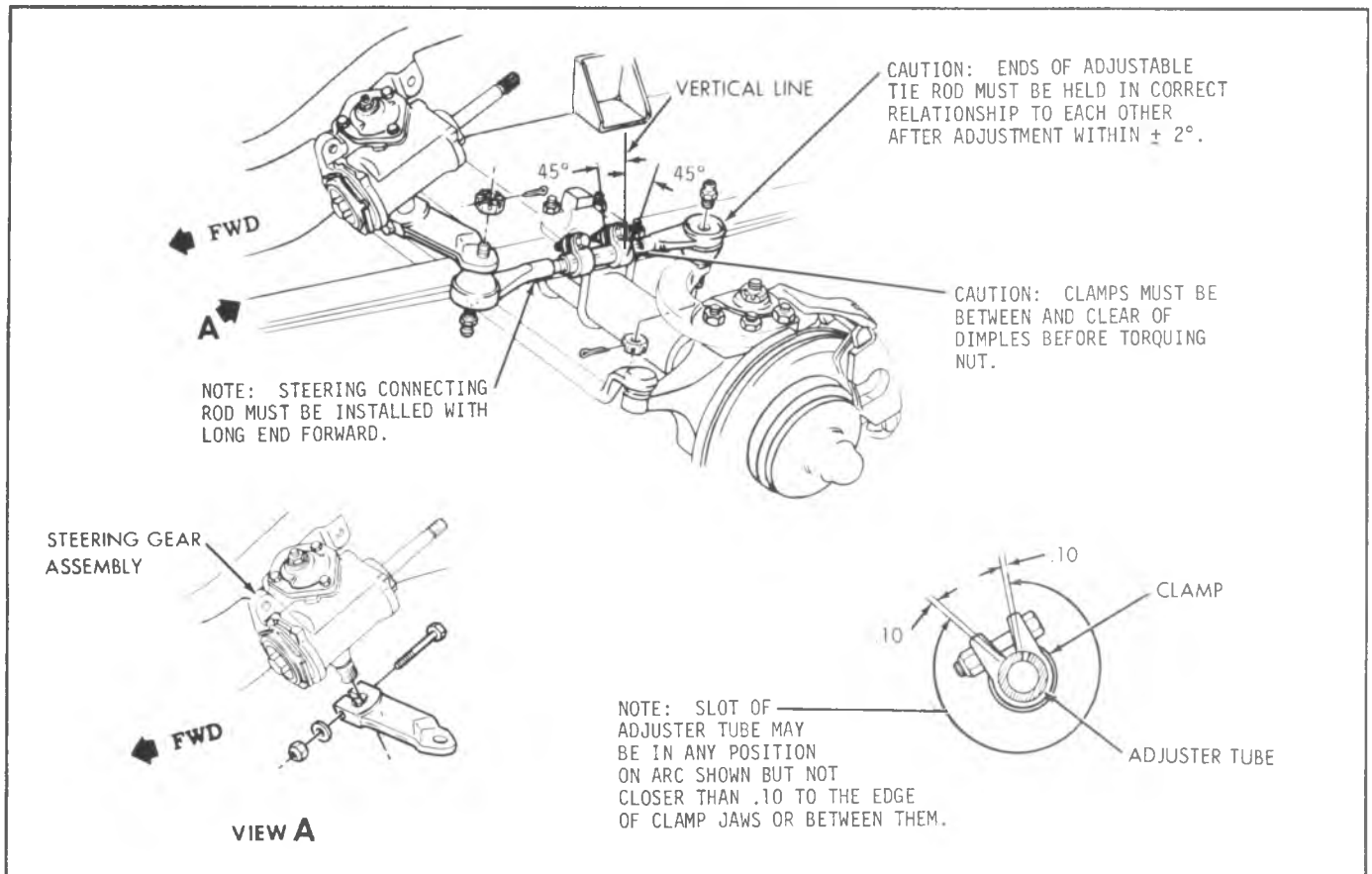

Fig. 3B1-7--Adjustable Connecting Rod Assembly - K Series

## STEERING CONNECTING ROD (K MODELS ONLY)

### Removal

1. Remove cotter pins from ball studs, and then remove the castellated nuts.
2. Remove ball studs from steering arm and pitman arm boss with a heavy hammer and striking other side of boss with lighter hammer (similar to method shown in (Fig. 3B5-5).

### Installation

**NOTICE:** See the NOTICE on page 1 of this section regarding the fasteners referred to in step 3.

1. Make sure that threads on ball studs and in ball stud nuts are clean and smooth. If threads are not clean and

smooth, ball studs may turn in connecting rod when attempting to tighten nut. Check condition of ball stud seals-replace if necessary.

2. Install ball studs and torque to 120 N·m, 89 ft. lbs. Never back off nut to install cotter pin, always tighten nut to next slot that lines up with hole in stud.
3. Install ball stud nuts and to 95 N·m (70 ft. lbs.)
4. Install cotter pins and lubricate ball studs. For proper alignment and orientation of connecting rod clamps see Figure 3B1-7.

## SPECIFICATIONS AND SPECIAL TOOLS

Refer to Specifications and Special Tools at end of Section 3B4.

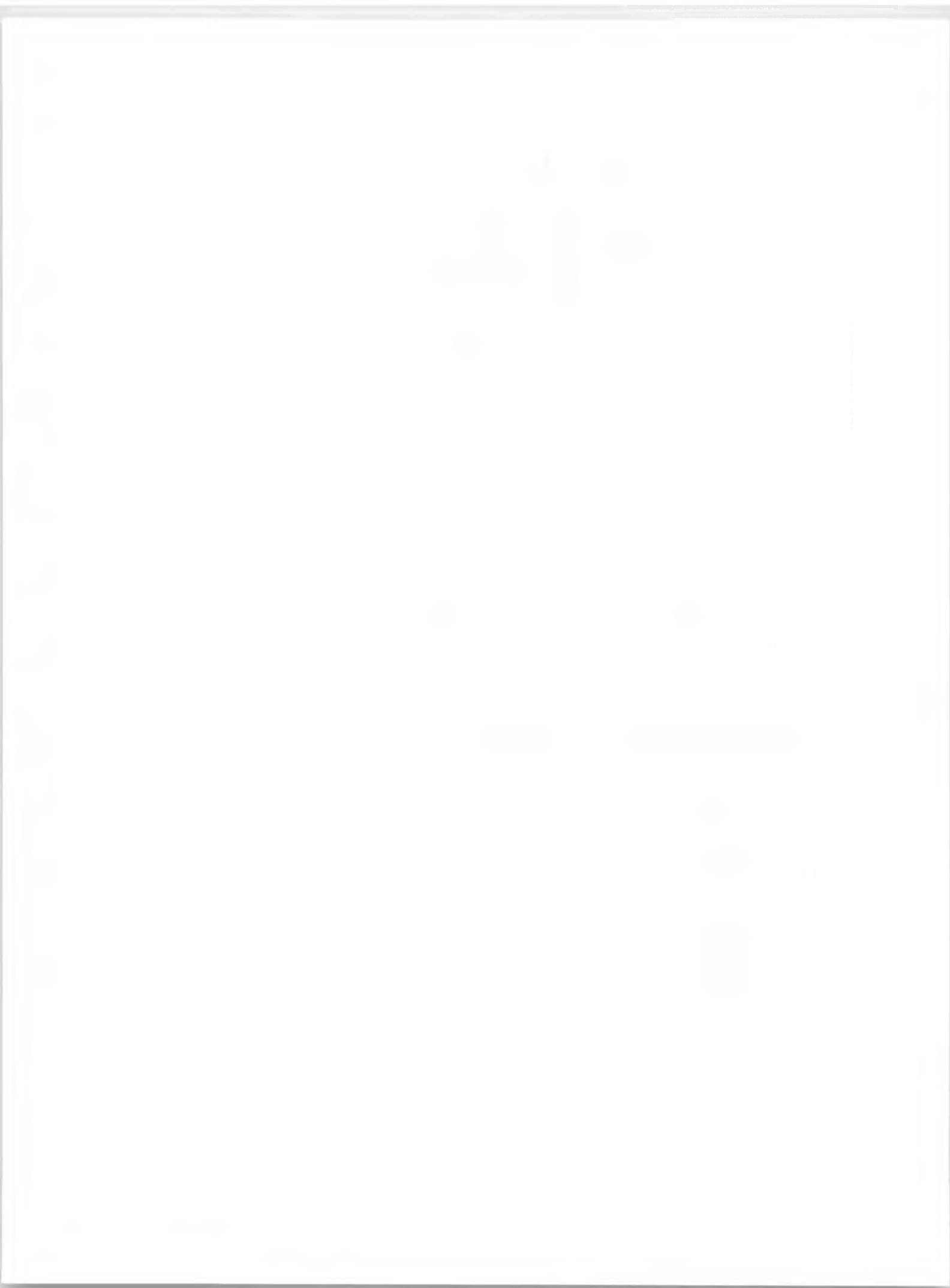

## SECTION 3B2

# MANUAL STEERING GEAR

The following notice applies to one or more steps in the assembly procedure of components in this portion of the manual as indicated at appropriate locations by the terminology "See Notice on page 1 of this Section".

**NOTICE:** This fastener is an important attaching part in that it could affect the performance of vital components and systems, and/or could result in major repair expense. It must be replaced with one of the same part number or with an equivalent part if replacement becomes necessary. Do not use a replacement part of lesser quality or substitute design. Torque values must be used as specified during reassembly to assure proper retention of this part.

### CONTENTS

|                                   |       |
|-----------------------------------|-------|
| General Description.....          | 3B2-1 |
| Maintenance and Adjustments ..... | 3B2-2 |
| On-Vehicle Service .....          | 3B2-3 |
| Manual Gear.....                  | 3B2-3 |
| Pitman Shaft Seal.....            | 3B2-4 |
| Unit Repair.....                  | 3B2-6 |
| .....                             |       |

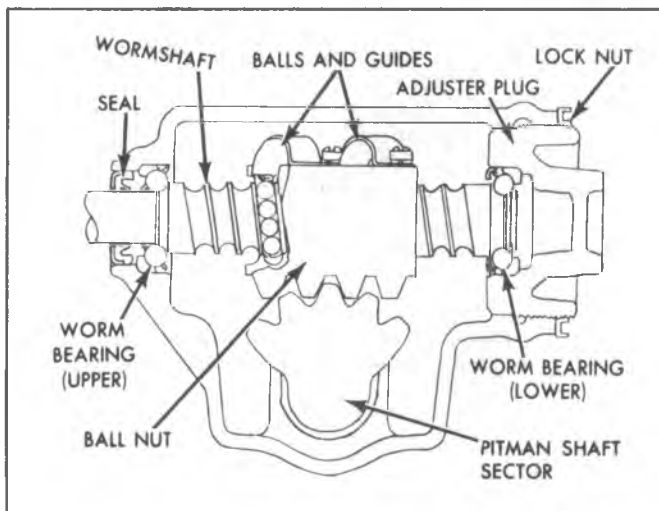

Fig. 3B2-1--Manual Steering Gear

### GENERAL DESCRIPTION

The steering gear is of the recirculating ball type. This gear provides for ease of handling by transmitting forces from the wormshaft to the pitman shaft through the use of ball bearings.

## MAINTENANCE AND ADJUSTMENTS

### LUBRICATION OF MANUAL STEERING GEAR

The manual steering gear is factory-filled with steering gear lubricant. Seasonal change of this lubricant should not be performed and the housing should not be drained—**no lubrication is required for the life of the steering gear.**

According to the intervals listed in Section 0B, the manual gear should be inspected for seal leakage (**actual solid grease - not just oily film**). If a seal is replaced or the gear is overhauled, the gear housing should be refilled with **1051052 (13 oz. container) Steering Gear Lubricant which meets GM Specification GM 4673M, or its equivalent.**

**NOTICE:** Do not use EP Chassis Lube, which meets GM Specification GM 6031M, to lubricate the gear **DO NOT OVER-FILL** the gear housing, or damage may occur to the gear.

### ADJUSTMENT OF MANUAL STEERING GEAR

**NOTICE:** See Notice on page one of this section regarding the fasteners referred to in steps 9d and 10.

Before any adjustments are made to the steering gear attempt to correct complaints of loose or hard steering, or other wheel disturbances, a careful check should be made of front end alignment, shock absorbers, wheel balance and tire pressure for possible steering system problems. See Diagnosis earlier in this section.

Correct adjustment of steering gear is very important. While there are but two adjustments to be made, the following procedure must be followed step-by-step in the order given.

1. Disconnect the battery ground cable.
2. Raise the vehicle.
3. Remove the pitman arm nut. Mark the relationship of the pitman arm to the pitman shaft. Remove the pitman arm with Tool J-6632 or J-5504 as shown in Figure 3B2-4.
4. Loosen the steering gear adjuster plug locknut and back the adjuster plug off 1/4 turn (Fig. 3B2-5).
5. Remove the horn shroud or button cap.

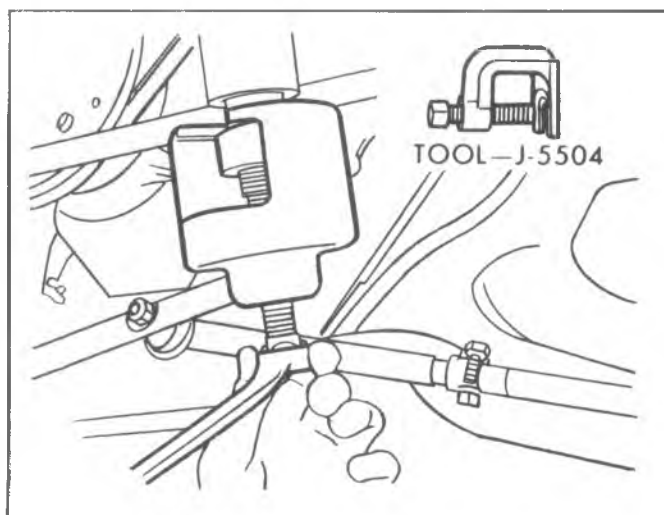

Fig. 3B2-4--Removing Pitman Arm

6. Turn the steering wheel gently in one direction until stopped by the gear; then turn back one-half turn.

**NOTICE:** Do not turn the steering wheel hard against the stops when the steering linkage is disconnected from the gear as damage to the ball guides could result.

7. Measure and record "bearing drag" by applying a torque wrench with a socket on the steering wheel nut and rotating through a 90° arc (Fig. 3B2-6). Do not use a torque wrench having a maximum torque reading of more than 50 inch pounds.
8. Adjust "thrust bearing preload" by tightening the adjuster plug until the proper "thrust loading preload" is obtained (See specifications section). When the proper preload has been obtained, tighten the adjuster plug locknut to specifications and recheck torque. If the gear feels "lumpy" after adjustment, there is probably damage in the bearings due to severe impact or

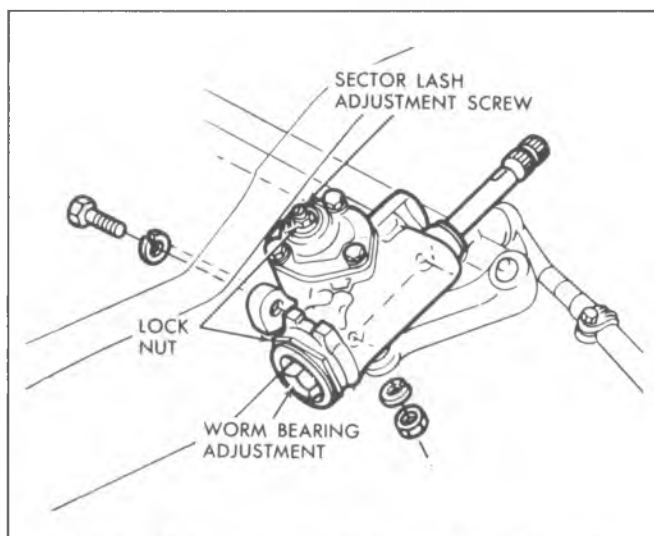

Fig. 3B2-5--Steering Gear Adjustment Points-Typical

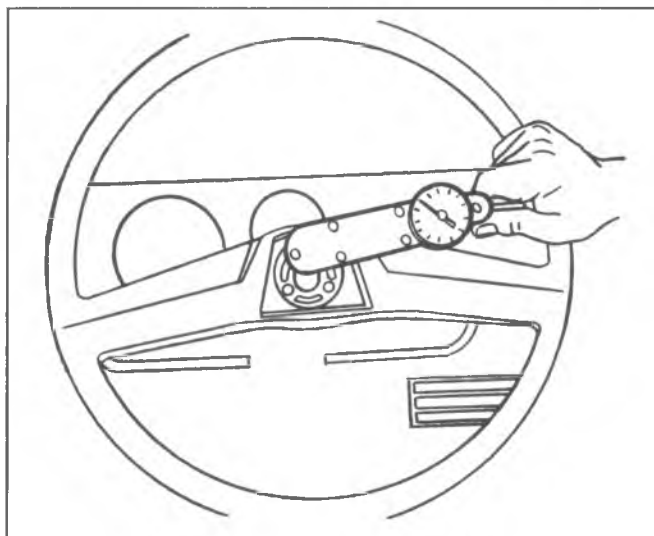

Fig. 3B2-6--Checking Torque at Steering Wheel



improper adjustment; the gear must be disassembled and inspected for replacement of damaged parts.

9. Adjust "over-center preload" as follows:
  - a. Turn the steering wheel gently from one stop all the way to the other carefully counting the total number of turns. Turn the wheel back exactly half-way, to center position.
  - b. Turn the lash adjuster screw clockwise to take out all lash between the ball nut and pitman shaft sector teeth and then tighten the locknut.
  - c. Check the torque at the steering wheel, taking the highest reading as the wheel is turned through center position. See Specifications for proper over-center preload.
  - d. If necessary, loosen locknut and readjust lash adjuster screw to obtain proper torque. Tighten the locknut to specifications and again check torque reading through center of travel. If maximum specification is exceeded, turn lash adjuster screw counterclockwise, then come up on adjustment by turning the adjuster in a clockwise motion.
10. Reassemble the pitman arm to the pitman shaft, lining up the marks made during disassembly. Torque the pitman shaft nut to specifications.  
 If a clamp type pitman arm is used, spread the pitman arm just enough, with a wedge, to slip the arm onto the pitman shaft. Do not spread the clamp more than required to slip over pitman shaft with hand pressure. Do not hammer the pitman arm onto the pitman shaft. Be sure to install the hardened steel washer before installing the nut.

11. Install the horn button cap or shroud and connect the battery ground cable.
12. Lower the vehicle to the floor.

**STEERING GEAR HIGH POINT CENTERING**

1. Set front wheels in straight ahead position. This can be checked by driving vehicle a short distance on a flat surface to determine steering wheel position at which vehicle follows a straight path.
2. With front wheels set straight ahead, check position of mark on wormshaft designating steering gear high point. This mark should be at the top side of the shaft at 12 o'clock position and lined up with the mark in the coupling lower clamp.
3. On C, G and P series, if the gear has been moved off high point when setting wheel in straight ahead position, loosen adjusting sleeve clamps on both left and right hand tie rods. Then turn both sleeves an equal number of turns in the same direction to bring gear back on high point.  
 Turning the sleeves an unequal number of turns or in different directions will disturb the toe-in setting of the wheels.
4. On K series, if the gear has been moved off high point when setting wheels in straight ahead position, loosen adjusting sleeve clamps on the connecting rod. Then turn sleeve to bring gear back on high point.
5. Readjust toe-in as outlined in Section 3A (if necessary).
6. Be sure to properly orient sleeves and clamps when fastening and torquing clamps to proper specifications.

**ON-VEHICLE SERVICE**

**STEERING GEAR**

**Removal**

1. Set the front wheels in straight ahead position by driving vehicle a short distance on a flat surface.

2. Remove the flexible coupling to steering shaft flange bolts (C-K models) or the lower universal joint pinch bolt (P models). Mark the relationship of the universal yoke to the wormshaft.
3. Mark the relationship of the pitman arm to the pitman shaft. Remove the pitman shaft nut or pitman arm pinch bolt and then remove the pitman arm from the pitman shaft using Puller J-6632 (Fig. 3B2-9).

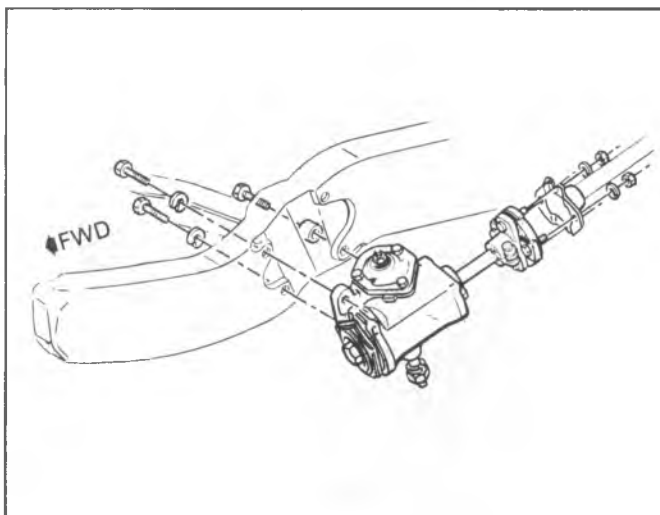

Fig. 3B2-7--Steering Gear Attachment, C-K Models

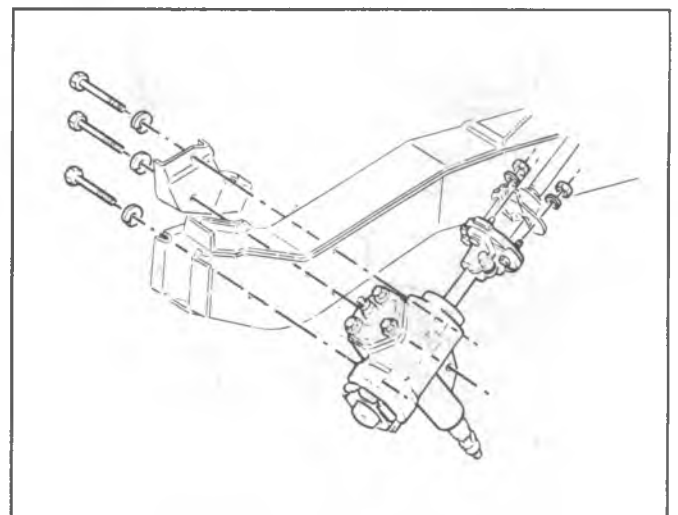

Fig. 3B2-8--Steering Gear Attachment, G-P Models

4. Remove the steering gear to frame bolts and remove the gear assembly.
5. **C-K Models** - Remove the flexible coupling pinch bolt and remove the coupling from the steering gear wormshaft.

#### Installation

**NOTICE:** See NOTICE on page 1 of this section regarding the fasteners referred to in steps 1a, 1c, 1d, 1e, 2b, 2c and 3.

#### 1. C-K Models

- a. Install the flexible coupling onto the steering gear wormshaft, aligning the flat in the coupling with the flat on the shaft. Push the coupling onto the shaft until the wormshaft bottoms on the coupling reinforcement. Install the pinch bolt and torque to specifications. The coupling bolt must pass through the shaft undercut.
- b. Place the steering gear in position, guiding the coupling bolt into the steering shaft flange.
- c. Install the steering gear to frame bolts and torque to specifications.
- d. If flexible coupling alignment pin plastic spacers were used, make sure they are bottomed on the pins, torque the flange bolt nuts to specifications and then remove the plastic spacers.
- e. If flexible coupling alignment pin plastic spacers were not used, center the pins in the slots in the steering shaft flange and then install and torque the flange bolt nuts to specifications.

#### 2. P Models

- a. Place the steering gear in position, guiding the wormshaft into the universal joint assembly and lining up the marks made at removal. If a new gear was installed, line up the mark on the wormshaft with the slit in the universal joint yoke.
- b. Install the steering gear to frame bolts and torque to specifications.
- c. Install the universal joint pinch bolt and torque to specification. The pinch bolt must pass through the shaft undercut.

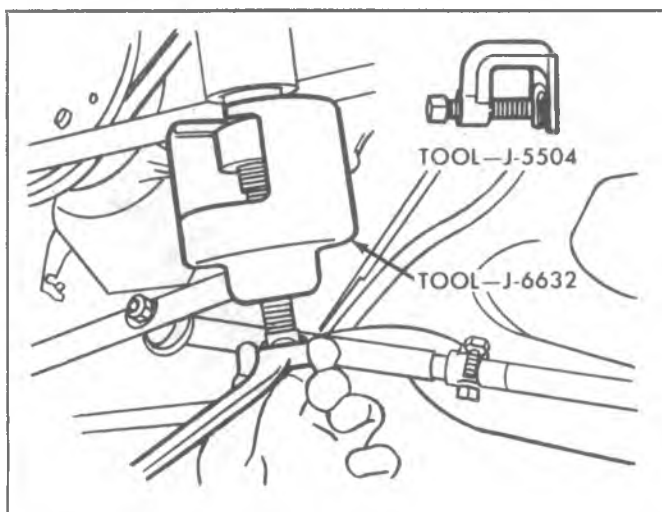

Fig. 3B2-9--Removing Pitman Arm-Typical

3. Install the pitman arm onto the pitman shaft, lining up the marks made at removal. Install the pitman shaft nut or pitman arm pinch bolt and torque to specifications.

If a clamp type pitman arm is used, spread the pitman arm just enough, with a wedge, to slip the arm onto the pitman shaft. Do not spread the clamp more than required to slip over pitman arm onto the pitman shaft. Be sure to install the hardened steel washer before installing the nut.

#### PITMAN SHAFT SEAL REPLACEMENT

A faulty seal may be replaced without removal of steering gear from C, G and P trucks by removing pitman arm as outlined under Maintenance and Adjustments - Steering Gear Adjustments and proceed as follows:

On K series vehicles remove the gear from the vehicle first.

1. Rotate the steering wheel from stop to stop, counting the total number of turns. Then turn back exactly half-way, placing the gear on center (the wormshaft flat should be at the 12 o'clock position).
2. Remove the three self-locking bolts attaching side cover to the housing and lift the pitman shaft and side cover assembly from the housing.
3. Pry the pitman shaft seal from the gear housing using a screwdriver and being careful not to damage the housing bore. See Fig. 3B2-10.

**NOTICE:** Inspect the lubricant in the gear for contamination. If the lubricant is contaminated in any way, the gear must be removed from the vehicle and completely overhauled as outlined in the Unit Repair Manual, or damage to the gear could result.

4. Coat the new pitman shaft seal with Steering Gear Lubricant meeting GM Specification GM4673M (or equivalent). Position the seal in the pitman shaft bore and tap into position using a suitable size socket.
5. Remove the lash adjuster lock nut. Remove the side cover from the pitman shaft assembly by turning the lash adjuster screw clockwise.

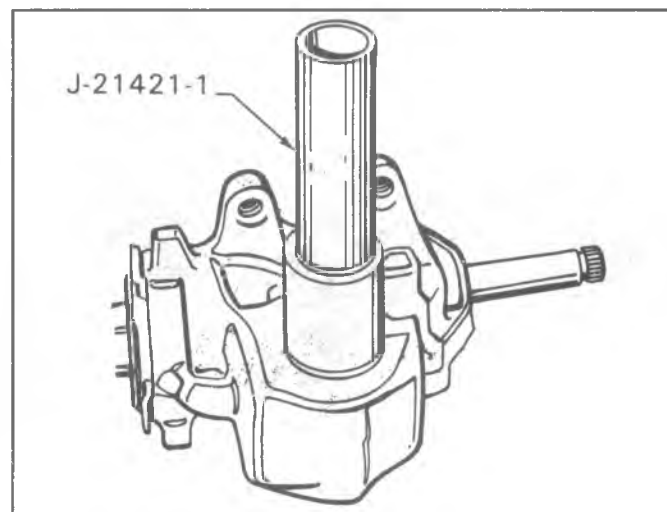

Fig. 3B2-10--Pitman Shaft Seal Replacement

6. Place the pitman shaft in the steering gear such that the center tooth of the pitman shaft sector enters the center tooth space of the ball nut.
7. Fill the steering gear housing with Steering Gear Lubricant meeting GM Specification GM4673M (or equivalent).
8. Install a new side cover gasket onto the gear housing.
9. Install the side cover onto the lash adjuster screw by reaching through the threaded hole in the side cover with a small screwdriver and turning the lash adjuster screw counter- clockwise until it bottoms and turns back in 1/4 turn.
10. Install the side cover bolts and torque to specifications.
11. Install the lash adjuster screw locknut, perform steering gear adjustment and install the pitman arm as outlined under "Maintenance and Adjustments".

On K series install the gear into the vehicle using previously outlined procedure.

#### **SPECIFICATIONS AND SPECIAL TOOLS**

Refer to Specifications and Special Tools at end of Section 3B4.

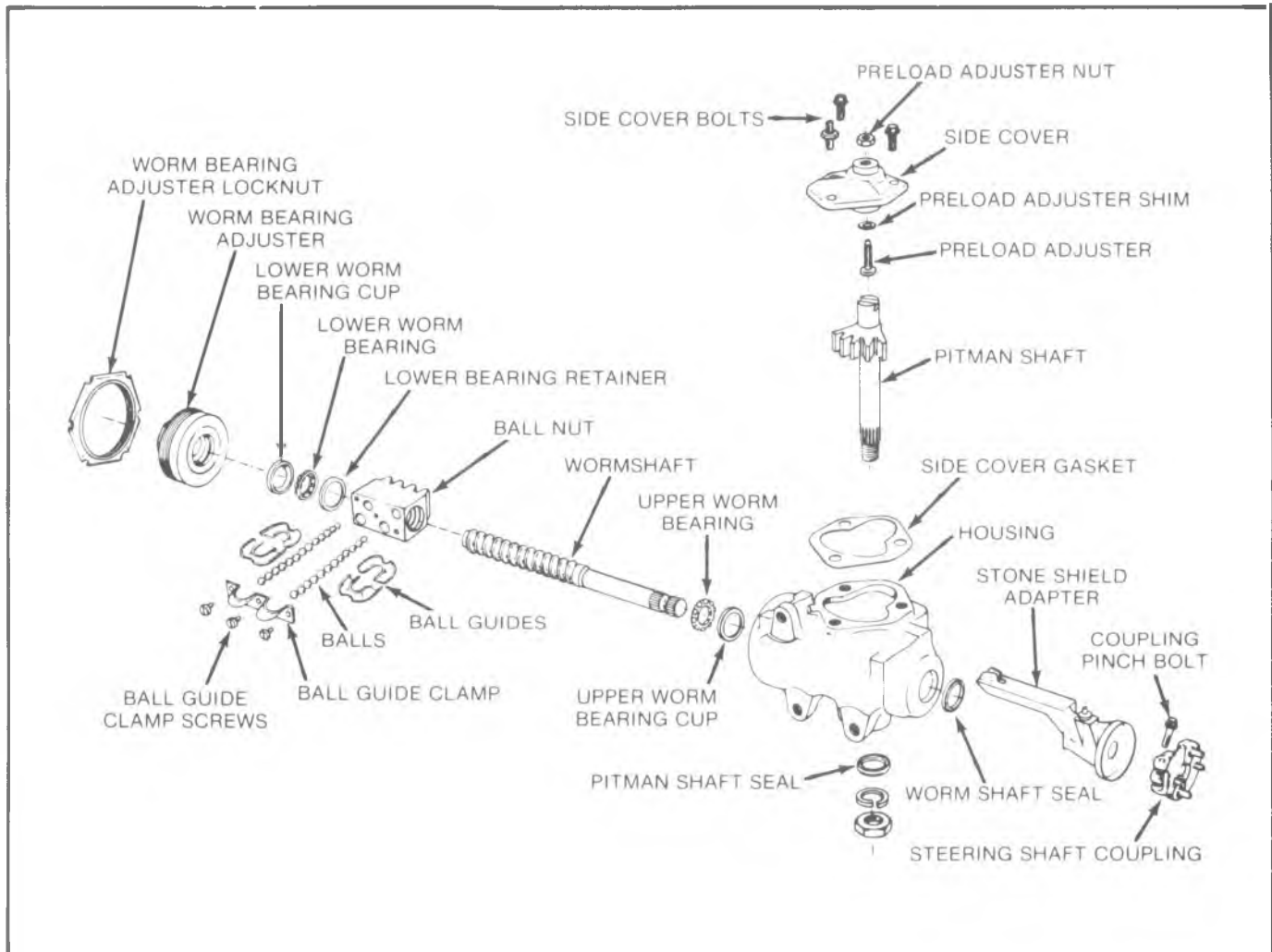
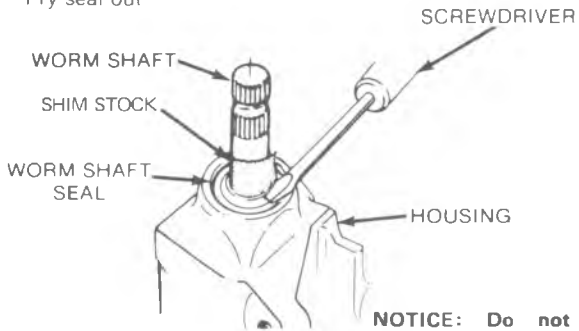

Fig. 3B2-11--Manual Steering Gear, Exploded View

### 1. REMOVE AND INSTALL WORM SHAFT SEAL-GEAR ASSEMBLED

**REMOVE**

1. Wrap 0.1 mm to 0.2 mm (.005" to .008") shim stock around shaft and insert between shaft and seal. Pry seal out.



**INSTALL**

1. Install parts as shown.

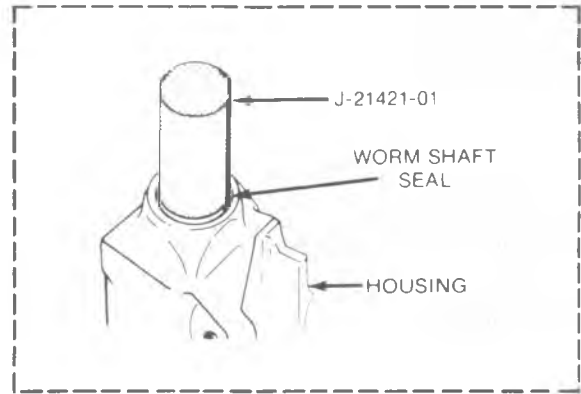

Install seal

**NOTICE:** Do not turn steering wheel hard against "stops" when linkage is disconnected, as damaged to the ends of ball guides may occur.

### 2. REMOVE AND INSTALL PITMAN SHAFT AND SIDE COVER

**REMOVE**

1. Center steering gear.
2. Remove parts as shown.

**INSTALL**

1. Before installing turn preload adjuster screw counter-clockwise until it bottoms, then back screw off one half turn.
2. Install parts as shown.

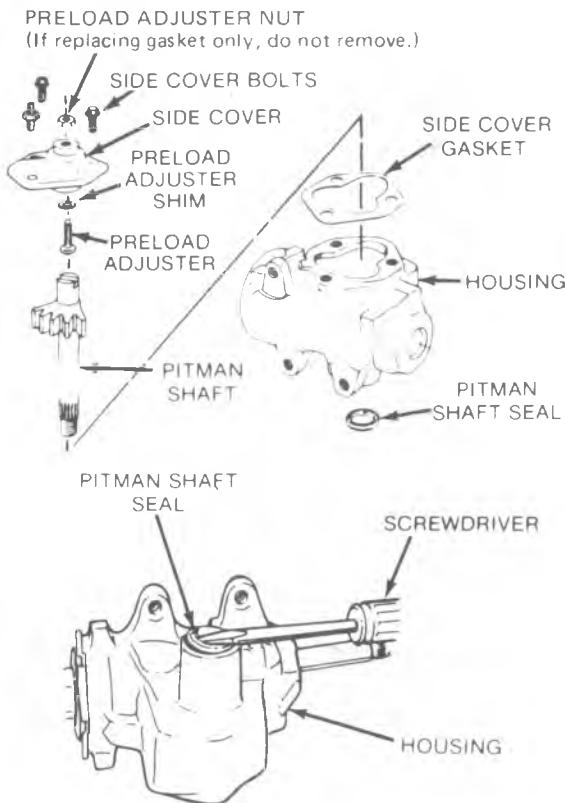

Checking end clearance

If clearance is greater than .05 mm (.002") a steering gear lash adjuster kit is available

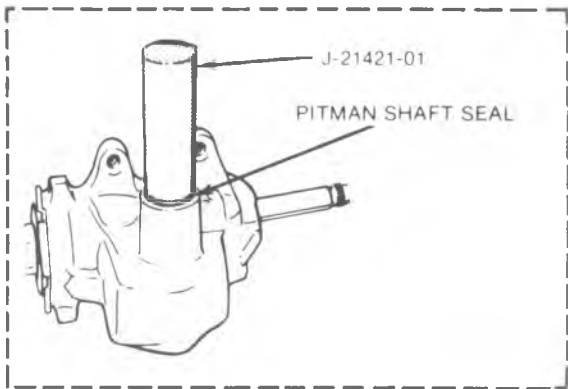
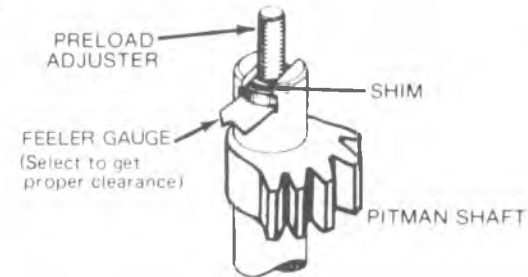

Install seal

**LUBRICATION**

The steering gear requires 3118 kg (11 oz.) of lubricant GM4673M or equivalent

Fig. 3B2-12--Manual Gear Overhaul, Chart A

### 3. REMOVE AND INSTALL WORMSHAFT AND BALL NUT

**REMOVE**

1. Loosen lock nut. Use punch against edge of slot.
2. Remove parts as shown.

**INSTALL**

1. Install parts as shown.

**NOTICE:** Use care that the ball nut does not run down to either end of the worm. Damage may be done to the ends of the ball guides if the ball nut is allowed to rotate until stopped at the end of the worm

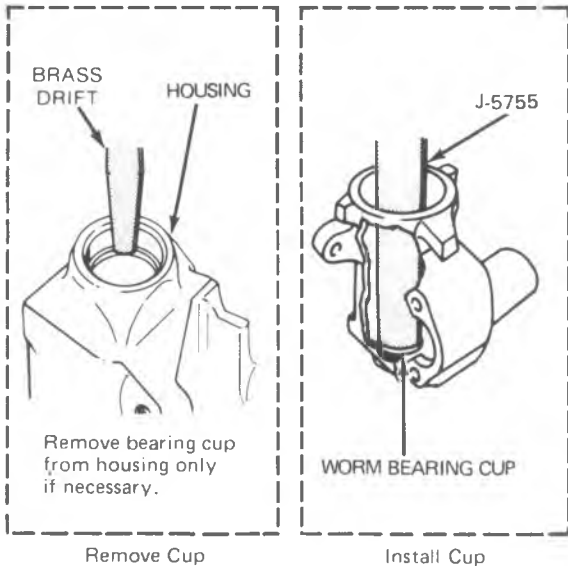
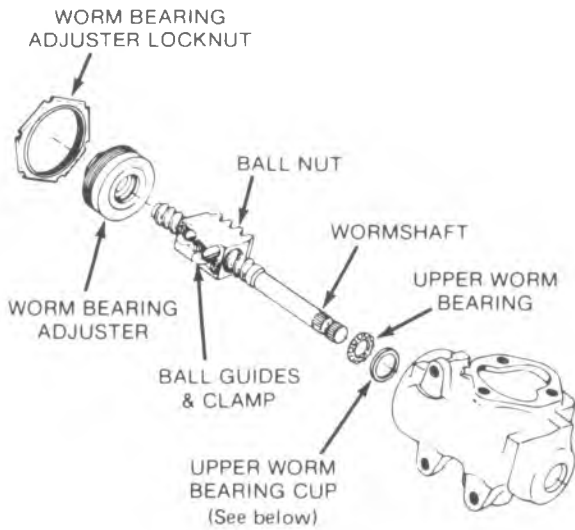

Remove bearing cup from housing only if necessary.

WORM BEARING CUP

Remove Cup

Install Cup

### 4. DISASSEMBLE AND ASSEMBLE WORM BEARING ADJUSTER

**DISASSEMBLE**

1. Pry lower bearing retainer out with screwdriver
2. Remove cup using J-5822 puller and slide hammer.

**ASSEMBLE**

1. Press cup into adjuster using J-5755.
2. Install parts as shown

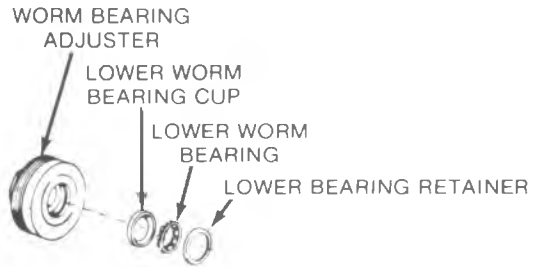

### 5. DISASSEMBLE AND ASSEMBLE WORMSHAFT AND BALL NUT

**DISASSEMBLE**

1. Disassemble parts as shown
2. Clean and inspect all parts for excessive wear

**ASSEMBLE**

1. Assemble parts as shown
2. Refer to Fig A for number of balls used

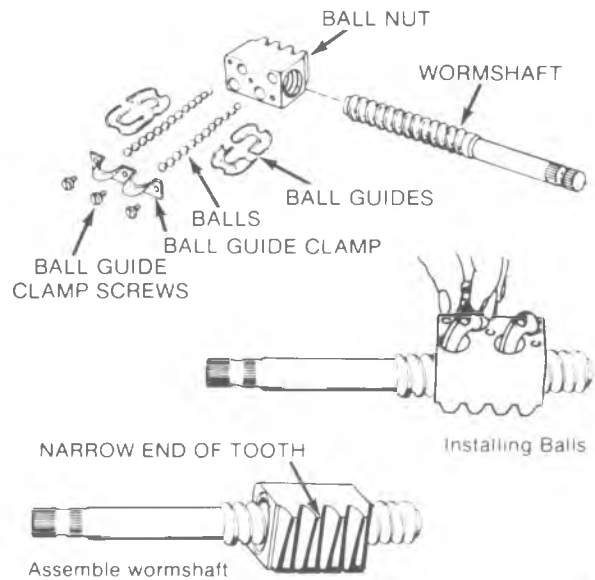

Assemble wormshaft

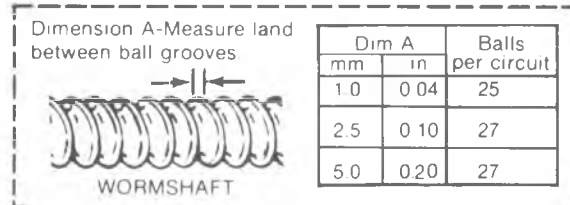

Dimension A-Measure land between ball grooves

| Dim A |      | Balls per circuit |
|-------|------|-------------------|
| mm    | in   |                   |
| 1.0   | 0.04 | 25                |
| 2.5   | 0.10 | 27                |
| 5.0   | 0.20 | 27                |

WORMSHAFT

Fig A

Fig. 3B2-13--Manual Gear Overhaul, Chart B

**6. ADJUST WORM BEARING PRELOAD**

1. Tighten worm bearing adjuster until it bottoms then loosen one-quarter turn
2. Carefully turn the wormshaft all the way to end of travel then turn back one-half turn
3. Tighten adjuster plug until torque wrench reads 0.6 to 1.0 N.m (5 to 8 in. lbs.)
4. Tighten locknut using punch against edge of slot.

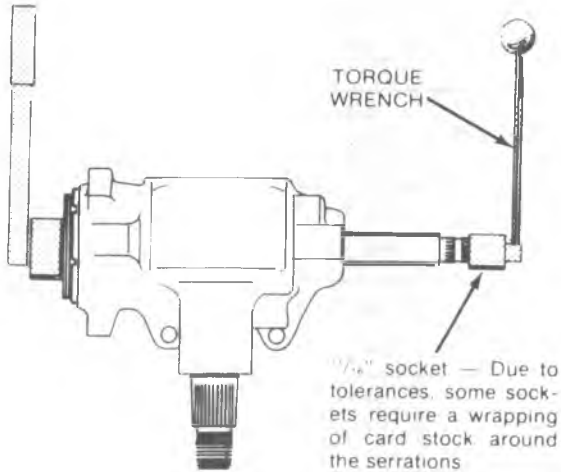

**7. ADJUST "OVER CENTER" PRELOAD**

A Back off preload adjuster until it stops, then turn it in one full turn.

B Turn adjuster in until torque to turn stub shaft is 0.5 to 1.2 N.m (4 to 10 in. lbs.) more than reading #1

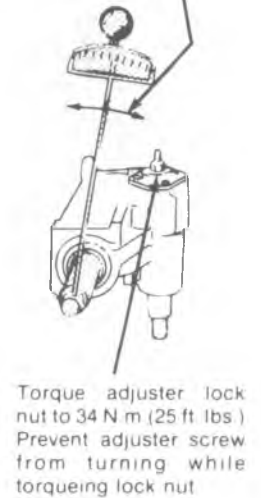
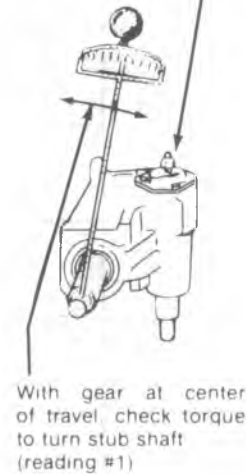

**ADJUSTMENT SPECIFICATIONS – MANUAL STEERING**

| ADJUSTMENT                  | TORQUE TO TURN WORM SHAFT |  |
|-----------------------------|---------------------------|--|
| Worm Bearing                | 0.6-1.0 N-m               | 5-8 In. Lbs.                                     |
| Over Center Preload         | 0.5-1.2 N-m               | 4-10 In. Lbs. in excess of Worm Bearing Preload. |
| Total Steering Gear Preload | 1.8 N-m                   | 16 In. Lbs. Maximum                              |

**RECOMMENDED TORQUE SPECIFICATIONS**

| MANUAL STEERING GEAR                 | N-m | FT. LB. |
|--------------------------------------|-----|---------|
| Gear to Frame Bolts                  | 95  | 70      |
| Pitman Shaft Nut                     |     |         |
|                                      | 251 | 185     |
| Side Cover Bolts                     | 40  | 30      |
| Pitman Shaft Adjusting Screw Locknut | 34  | 25      |
| Coupling Flange To Gear Pinch Bolt   | 40  | 30      |
| Coupling Clamp Nut (Starfire)        | 70  | 50      |
| Clamp To Ball Nut Screw              | 5.5 | 4       |

**TOOLS**

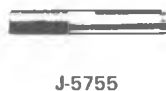

- J-21421-01 Seal Installer
- J-5755 Worm Bearing Cup Installer
- J-5822 Worm Bearing Adjuster Cup Puller

Fig. 3B2-14--Manual Gear Overhaul, Chart C

### STEERING GEAR RATIOS

| Vehicle    | Manual     |                  | Power        |                  |
|------------|------------|------------------|--------------|------------------|
|            | Gear Ratio | Overall Ratio    | Gear Ratio   | Overall Ratio    |
| G10-20     | 24:1       | 29.4:1 to 36.7:1 | 14:1         | 21.4:1 to 26.7:1 |
| G30        | 24:1       | 29.4:1 to 36.4:1 | 14:1         | 21.4:1 to 26.5:1 |
| P20-30     | —          | —                | 17.5:1       | 21.2:1 to 25.7:1 |
| Motor Home | —          | —                | 14:1         | 16.0:1 to 21.9:1 |
| C10        | 24:1       | 29.1:1 to 37.0:1 | 16:1 to 13:1 | 16.9:1 to 20.2:1 |
| C20-30     | 24:1       | 29.4:1 to 36.3:1 | 16:1 to 13:1 | 17.2:1 to 20.6:1 |
| K10-20     | —          | —                | 16:1 to 13:1 | 13.2:1 to 17.2:1 |

### MANUAL STEERING GEAR

| Components                  | All C-G           |
|-----------------------------|-------------------|
| Thrust Bearing Preload      | 5 to 8 lbs. in.   |
| Adjuster Plug Lock Nut      | 85 lbs. ft.       |
| Over Center Preload         | 4 to 10 lbs. in.* |
| Over Center Lock Nut        | 25 lbs. ft.       |
| Total Steering Gear Preload | 18 lbs. in. Max.  |

\* In excess of thrust bearing preload.

### POWER STEERING PUMP PRESSURES

| Vehicle        | Pressure        |                 |
|----------------|-----------------|-----------------|
| C10-30         | 1200 - 1300 psi |                 |
| G10-20-30      | w/o Hydroboost  | 900 - 1000 psi  |
| G30            | with Hydroboost | 1350 - 1450 psi |
| P10-30         | 1200 - 1300 psi |                 |
| Motor Home & K | 1350 - 1450 psi |                 |

Fig. 3B2--Specs



## SECTION 3B3

# POWER STEERING SYSTEM

The following notice applies to one or more steps in the assembly procedure of components in this portion of the manual as indicated at appropriate locations by the terminology. "See Notice on Page 1 of this section".

**NOTICE** This fastener is an important attaching part in that it could affect the performance of vital components and systems, and/or could result in major repair expense. It must be replaced with one of the same part number or with an equivalent part if replacement becomes necessary. Do not use a replacement part of lesser quality or substitute design. Torque values must be used as specified during reassembly to assure proper retention of this part.

### CONTENTS

|                                   |        |
|-----------------------------------|--------|
| General Description.....          | 3B3-1  |
| Maintenance and Adjustments ..... | 3B3-1  |
| On-Vehicle Service .....          | 3B3-4  |
| Power Steering Gear .....         | 3B3-4  |
| Power Steering Pump.....          | 3B3-4  |
| Power Steering Hoses.....         | 3B3-5  |
| Specifications .....              | 3B3-5  |
| Unit Repair.....                  | 3B3-11 |
| Special Tools.....                | 3B3-24 |

#### GENERAL DESCRIPTION

The steering gear is of the recirculating ball type. This gear provides for ease of handling by transmitting forces

from the wormshaft to the pitman shaft through the use of ball bearings.

## MAINTENANCE AND ADJUSTMENTS

#### LUBRICATION OF POWER STEERING PUMP

Check the fluid level in the pump reservoir according to the intervals listed in Section 0B. Use only an approved power steering lubricant in the pump.

**NOTICE:** Never use brake fluid in the power steering pump, or damage may occur.

#### ADJUSTMENTS

##### Power Steering Gear Adjustment Procedure

Adjustment of the steering gear in the vehicle is not recommended because of the difficulty encountered in adjusting the worm thrust bearing preload and the confusing effects of the hydraulic fluid in the gear. Since a gear adjustment is made only as a correction and not as a periodic adjustment, it is better to take the extra time and make the adjustment correctly the first time.

Since a handling stability complaint can be caused by improperly adjusted worm bearings as well as an improper gear over-center adjustment, it is necessary that the steering gear assembly be removed from the vehicle and both thrust bearing and over-center preload be checked and corrected as necessary. An in-vehicle check of the steering gear will not pin-point a thrust bearing looseness.

Before any adjustments are made to the steering gear attempt to correct complaints of loose or hard steering, or

other wheel disturbances, a careful check should be made of front end alignment, shock absorbers, wheel balance and tire pressure for possible steering system problems. See Diagnosis steps listed earlier in Section 3.

Once it is determined to make adjustments, refer to Section 3B of the Overhaul Manual for specific instructions.

#### STEERING GEAR HIGH POINT CENTERING

1. Set front wheels in straight ahead position. This can be checked by driving vehicle a short distance on a flat surface to determine steering wheel position at which vehicle follows a straight path.
2. With front wheels set straight ahead, check position of mark on wormshaft designating steering gear high point. This mark should be at the top side of the shaft at 12 o'clock position and lined up with the mark in the coupling lower clamp.
3. On C, G and P series, if gear has been moved off high point when setting wheel in straight ahead position, loosen the adjusting sleeve clamps on both left and right hand tie rods. Then turn both sleeves an equal number of turns in the same direction to bring gear back on high point.

Turning the sleeves an unequal number of turns or in different directions will disturb the toe-in setting of the wheels.

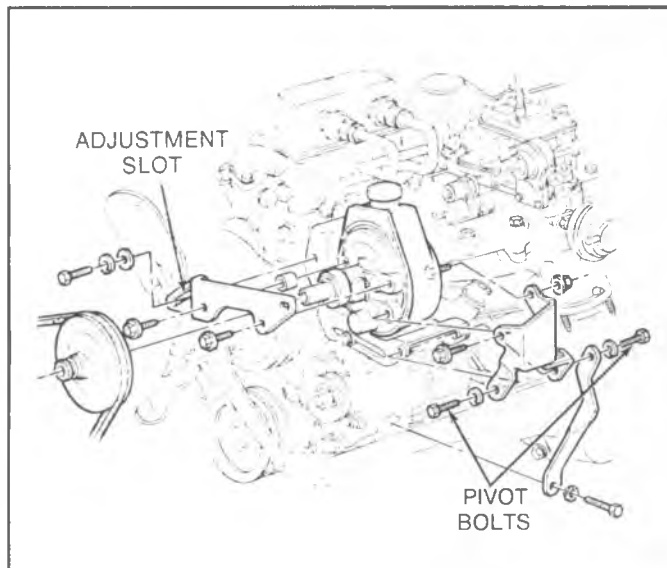

Fig. 3B3-1--Adjusting Pump Position

4. On K series, if the gear has been moved off high point when setting wheels in straight ahead position, loosen the adjusting sleeve clamps on the connecting rod. Then turn sleeve to bring gear back on high point.
5. Readjust toe-in as outlined in Section 3A (if necessary).
6. Be sure to properly orient sleeves and clamps, as shown in Section 3B1, when fastening and torquing clamps to proper specifications.

**PUMP BELT TENSION ADJUSTMENT**

1. Loosen pivot bolt and pump brace adjusting nuts. See Fig. 3B3-1.  
**NOTICE:** Do not move pump by prying against reservoir or by pulling on filler neck, or damage to the pump could occur.
2. Move pump, with belt in place until belt is tensioned to specifications as indicated by Tool J-23600 (Fig. 3B3-2). See Figure 3B3-3.
3. Tighten pump brace adjusting nut. Then tighten pivot bolt nut.

**FLUID LEVEL ADJUSTMENT**

1. Check oil level in the reservoir by checking the dipstick when oil is at operating temperature. On models equipped with remote reservoir, the oil level should be maintained approximately 1/2 to 1 inch from top with wheels in full left turn position.
2. Fill, if necessary, to proper level with GM Power Steering Fluid or equivalent.

**NOTICE:** Never use brake fluid in the power steering pump, or damage may occur.

**BLEEDING HYDRAULIC SYSTEM**

1. Fill oil reservoir to proper level and let oil remain undisturbed for at least two minutes.
2. Start engine and run only for about two seconds.
3. Add oil if necessary.

4. Repeat above procedure until oil level remains constant after running engine.
5. Raise front end of vehicle so that wheels are off the ground.
6. Increase engine speed to approximately 1500 rpm.
7. Turn the wheels (off ground) right and left, lightly contacting the wheel stops.
8. Add oil if necessary.
9. Lower the vehicle and turn wheels right and left on the ground.
10. Check oil level and refill as required.
11. If oil is extremely foamy, allow vehicle to stand a few minutes with engine off and repeat above procedure.
  - a. Check belt tightness and check for a bent or loose pulley. (Pulley should not wobble with engine running.)
  - b. Check to make sure hoses are not touching any other parts of the truck, particularly sheet metal except where design calls for a clamp.
  - c. Check oil level, filling to proper level if necessary, following operations 1 through 10. This step and Step "d" are extremely important as low oil level and/or air in the oil are the most frequent causes of objectional pump noise.
  - d. Check the presence of air in the oil. If air is present, attempt to bleed system as described in operations 1 through 10. If it becomes obvious that the pump will not bleed after a few trials, proceed as outlined under Hydraulic System Checks.

**HYDRAULIC SYSTEM CHECKS**

The following procedure outlines methods to identify and isolate power steering hydraulic circuit difficulties. The test provides means of determining whether power steering system hydraulic parts are actually faulty. This test will result in readings indicating faulty hydraulic operation, and will help to identify the faulty component.

Before performing hydraulic circuit test, carefully check belt tension, fluid level and condition of driving pulley.

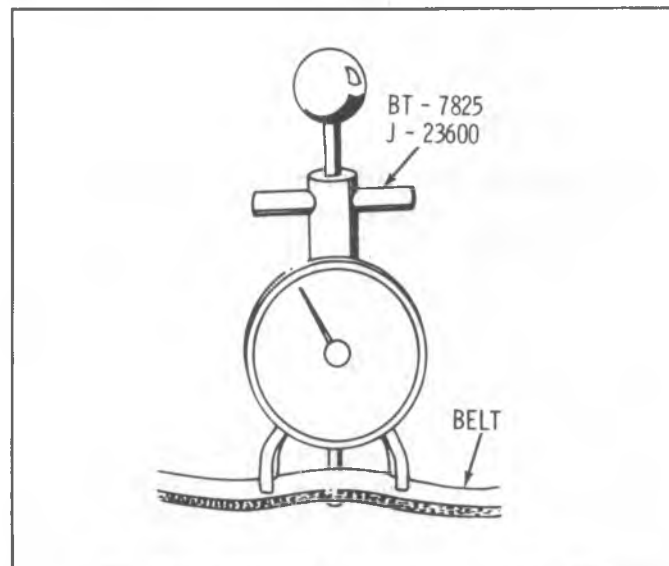

Fig. 3B3-2--Checking Belt Tension with J-23600

BELT TENSION

|                         | 5/16"<br>WIDE              | 3/8"<br>WIDE                | 15/32"<br>WIDE              |
|-------------------------|----------------------------|-----------------------------|-----------------------------|
| <b>NEW BELT</b>         | 350 N Max.<br>80 Lbs. Max. | 620 N Max.<br>140 Lbs. Max. | 750 N Max.<br>165 Lbs. Max. |
| <b>USED BELT</b>        | 200 N Min.<br>50 Lbs. Min. | 300 N Min.<br>70 Lbs. Min.  | 400 N Min.<br>90 Lbs. Min.  |
| <b>USED COGGED BELT</b> |                            | 250 N Min.<br>60 Lbs. Min.  |                             |

Fig. 3B3-3--Belt Tension Chart

### Power Steering System Test

Engine must be at normal operating temperature. Inflate front tires to correct pressure. All tests are made with engine idling. Check idle adjustment and, if necessary, adjust engine idle speed to correct specifications listed in Section 6C and proceed as follows:

1. With engine **NOT** running disconnect pressure hose from pump and install Tool J-5176 using a spare pressure hose between gage and pump. Gage must be between shut-off valve and pump (Fig. 3B3-4). Open shut-off valve.
2. Remove filler cap from pump reservoir and check fluid level. Fill pump reservoir to full mark on dipstick. Start engine and, momentarily holding steering wheel against stop, check connections at Tool J-5176 for leakage.
3. Bleed system as outlined under Maintenance and Adjustments.
4. Insert thermometer (Tool J-5421) in reservoir filler opening. Move steering wheel from stop to stop several times until thermometer indicates that hydraulic fluid in reservoir has reached temperature of 150° to 170°F.

**NOTICE:** To prevent scrubbing flat spots on tires, do not turn steering wheel more than five times without rolling vehicle to change tire-to-floor contact area.

5. Start engine and check fluid level adding any fluid if required. When engine is at normal operating temperature, the initial pressure read on the gage (valve open) should be in the 80-125 PSI range. Should this pressure be in excess of 200 PSI, check the hoses for restrictions and the poppet valve for

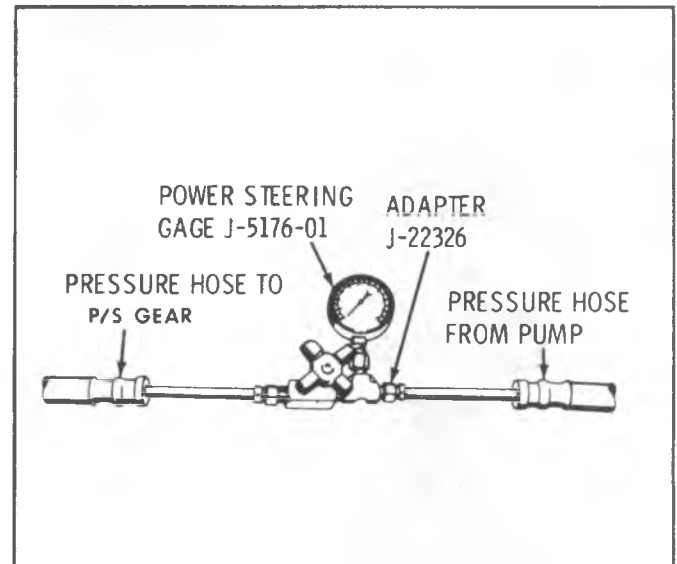

Fig. 3B3-4--Checking Power Steering Pressures

proper assembly.

6. Close gate valve fully 3 times. Record the highest pressure attained each time.

**NOTICE:** Do not leave valve fully closed for more than 5 seconds as the pump could be damaged internally.

- a. If the pressures recorded are within the listed specs and the range of readings are within 50 PSI, the pump is functioning within specs. (Ex. Spec. 1250-1350 PSI - readings - 1270-1275-1280).
  - b. If the pressures recorded are high, but do not repeat with 50 PSI, the flow controlling valve is sticking. Remove the valve, clean it and remove any burrs using crocus cloth or fine hone. If the system contains some dirt, flush it. If it is exceptionally dirty, both the pump and the gear must be completely disassembled, cleaned, flushed and reassembled before further usage.
  - c. If the pressures recorded are constant, but more than 100 PSI, below the low listed spec., replace the flow control valve and recheck. If the pressures are still low, replace the rotating group in the pump.
7. If the pump checks within specifications, leave the valve open and turn (or have turned) the steering wheel into both corners. Record the highest pressures and compare with the maximum pump pressures recorded. If this pressure cannot be built in either (or one) side of the gear, the gear is leaking internally and must be disassembled and repaired. See the current Overhaul Manual.
  8. Shut off engine, remove testing gage, spare hose, reconnect pressure hose, check fluid level and/or make needed repairs.

## ON-VEHICLE SERVICE

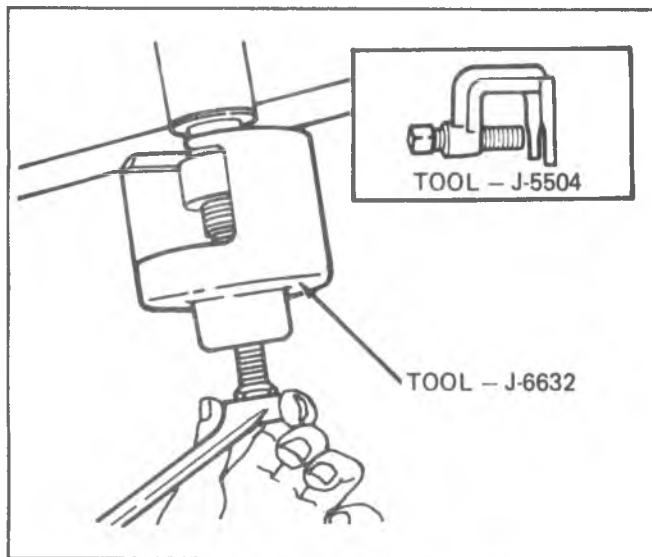

Fig. 3B3-5--Removing Pitman Arm

### POWER STEERING GEAR

#### Removal

1. Disconnect hoses at gear. When hoses are disconnected, secure ends in raised position to prevent drainage of oil. Cap or tape the ends of the hoses to prevent entrance of dirt.
2. Install two plugs in gear fittings to prevent entrance of dirt.
3. Remove the flexible coupling to steering shaft flange bolts (G, C and K models) or the lower universal joint pinch bolt (P models). Mark the relationship of the universal yoke to the stub shaft.
4. Mark the relationship of the pitman arm to the pitman shaft. Remove the pitman shaft nut or pitman arm pinch bolt and then remove the pitman arm from the pitman shaft using Puller J-6632 (Fig. 3B3-5).
5. Remove the steering gear to frame bolts and remove the gear assembly.
6. G, C and K Models - Remove the flexible coupling pinch bolt and remove the coupling from the steering gear stub shaft.

#### Installation (Fig. 3B3-6)

**NOTICE:** (See NOTICE on Page 1 of this section regarding the fasteners referred to in Steps 1, 3, 4 and 5.

1. Install the flexible coupling onto the steering gear stub shaft, aligning the flat in the coupling with the flat on the shaft. Push the coupling onto the shaft until the stub shaft bottoms on the coupling reinforcement. Install the pinch bolt and torque to specifications.

**NOTICE:** The coupling bolt must pass through the shaft undercut, or damage to the components could occur.

2. Place the steering gear in position, guiding the coupling bolt into the steering shaft flange.
3. Install the steering gear to frame bolts and torque to specifications.

4. If flexible coupling alignment pin plastic spacers were used, make sure they are bottomed on the pins, tighten the flange bolt nuts to specifications and then remove the plastic spacers.
5. If flexible coupling alignment pin plastic spacers were not used, center the pins in the slots in the steering shaft flange and then install and torque the flange bolt nuts to specifications.

#### P Models

- a. Place the steering gear in position, guiding the stud shaft into the universal joint assembly and lining up the marks made at removal. If a new gear was installed, line up the mark on the stub shaft with the mark on the universal yoke.
- b. Install the steering gear to frame bolts and torque to specifications.
- c. Install the universal joint pinch bolt and torque to specification. The pinch bolt must pass through the shaft undercut.

#### All Models

6. Install the pitman arm onto the pitman shaft, lining up the marks made at removal. Install the pitman shaft nut or pitman arm pinch bolt and torque to specifications.
7. Remove the plugs and caps from the steering gear and hoses and connect the hoses to the gear. Tighten the hose fittings to specified torque.

### POWER STEERING PUMP (3B3-7 THROUGH 3B3-19)

#### Removal

1. Disconnect hoses at pump. When hoses are disconnected, secure ends in raised position to prevent drainage of oil. Cap or tape the ends of the hoses to prevent entrance of dirt.

On Models with remote reservoir, disconnect reservoir

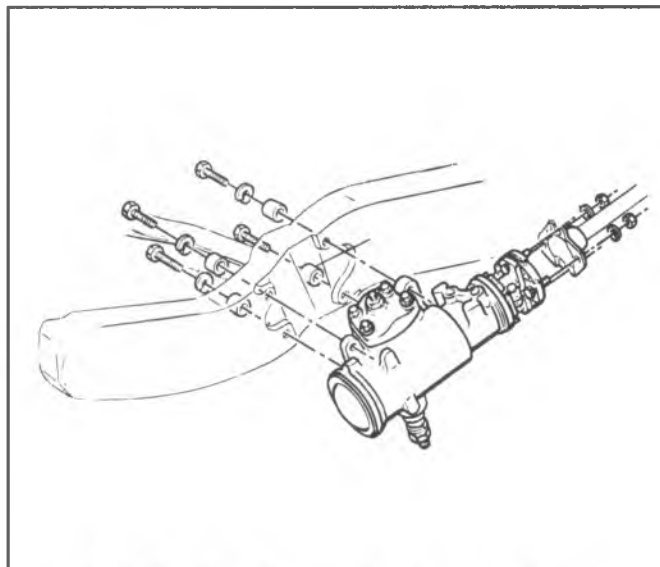

Fig. 3B3-6--Power Steering Gear Mounting-Typical

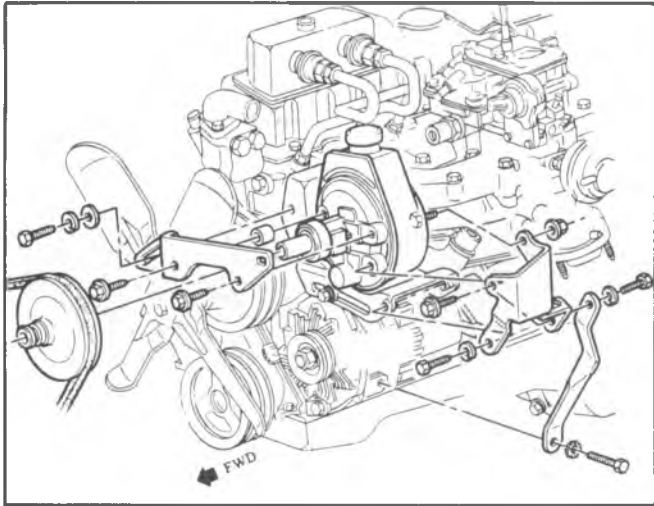

Fig. 3B3-7--P/S Pump Mounting; CK100, CK200 (03) with LE3 NA5 Engines

hose at pump and secure in raised position. Cap hose pump fittings.

2. Install two caps at pump fittings to prevent drainage of oil from pump.
3. Loosen bracket-to-pump mounting nuts.
4. Remove pump belt.
5. Remove pump from attaching parts and remove pump from vehicle.

#### Installation

1. Position pump assembly on vehicle and install attaching parts loosely.
2. Connect and tighten hose fittings.
3. Fill reservoir. Bleed pump by turning pulley backward (counter-clockwise as viewed from front) until air bubbles cease to appear.
4. Install pump belt over pulley.
5. Tension belt as outlined under "Pump Belt Tension-Adjustment" in this section.
6. Bleed as outlined under "Bleeding Power Steering System".

#### POWER STEERING HOSES

When servicing the power steering hoses be sure to align the hoses in their correct position as shown in the following figures.

It is important that the power steering hoses be installed correctly. Hoses installed out of position may be subjected to chafing or other abuses during sharp turns. Do not twist hoses unnecessarily during installation.

**NOTICE:** Do not start engine with any power steering hose disconnected, or damage to the components could occur.

#### SPECIFICATIONS

Refer to Specifications at end of Section 3B4.

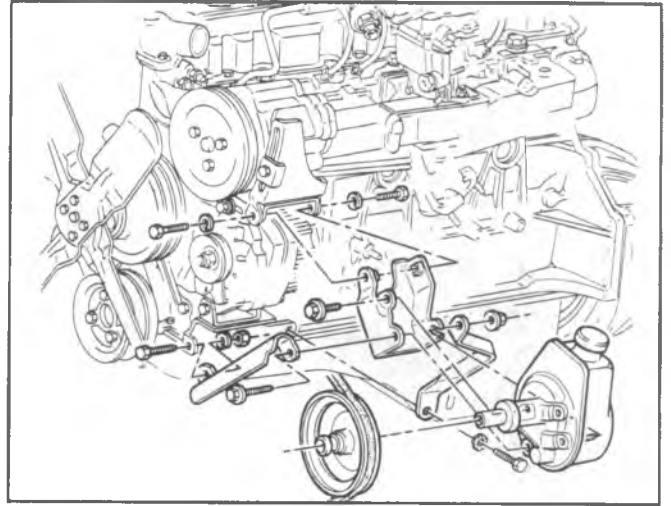

Fig. 3B3-8--P/S Pump Mounting; CK200, CK300 with LE3/L25 NB2 Engines

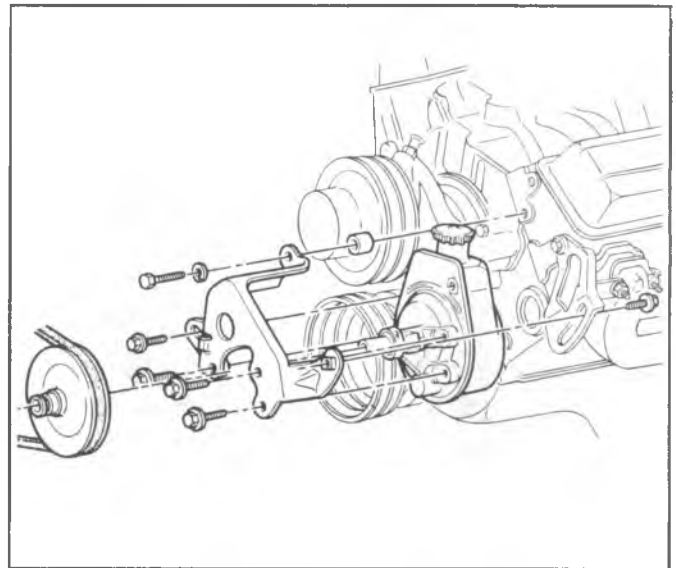

Fig. 3B3-9--P/S Pump Mounting; CK100, CK200, CK300-LE9, LF3, LS9, LT9 (Exc. C60, C69)

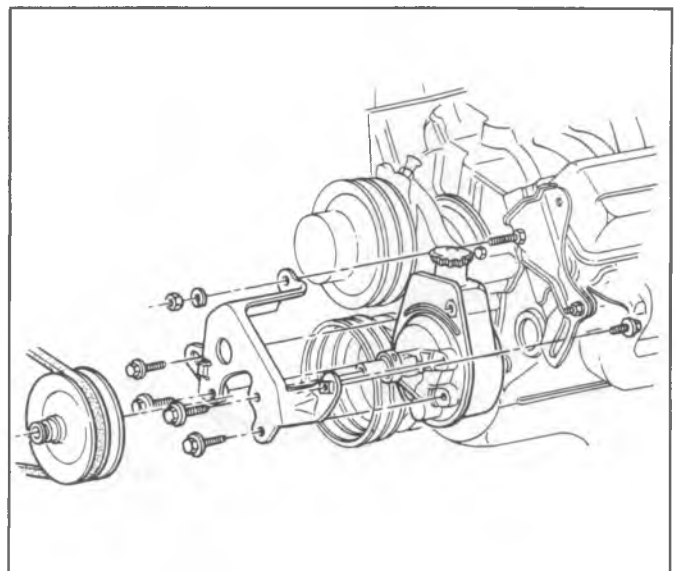

Fig. 3B3-10--P/S Pump Mounting; CK100, CK200, CK300-LE9, LS9, LT9 and C69

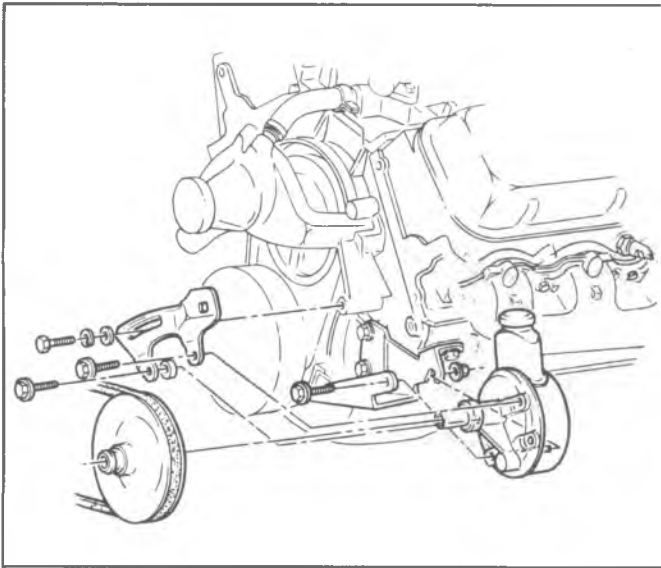

Fig. 3B3-11--P/S Pump Mounting; C100, C200, C300 with LE8 Engine

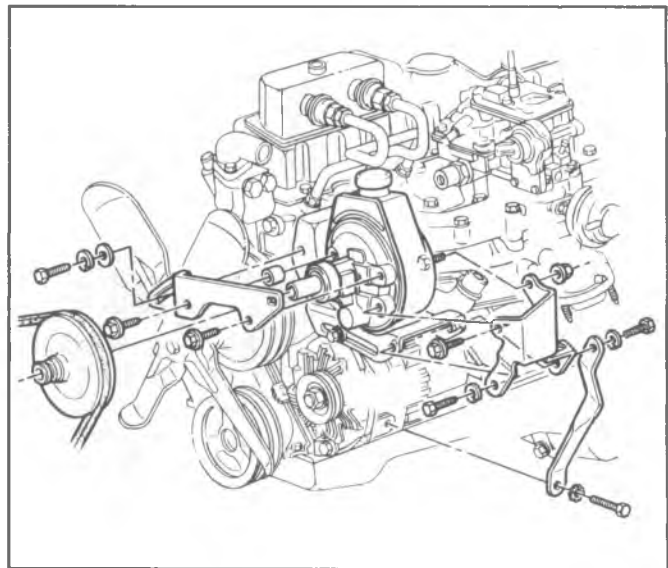

Fig. 3B3-14--P/S Pump Mounting; G100, G200, G300-LE3 NB2

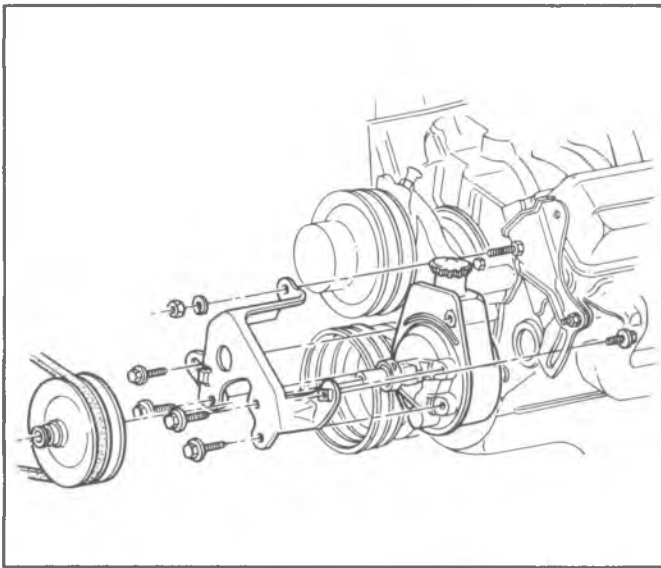

Fig. 3B3-12--P/S Pump Mounting; CK100, CK200, CK300-LE9, LF3, L89, LT9 C60

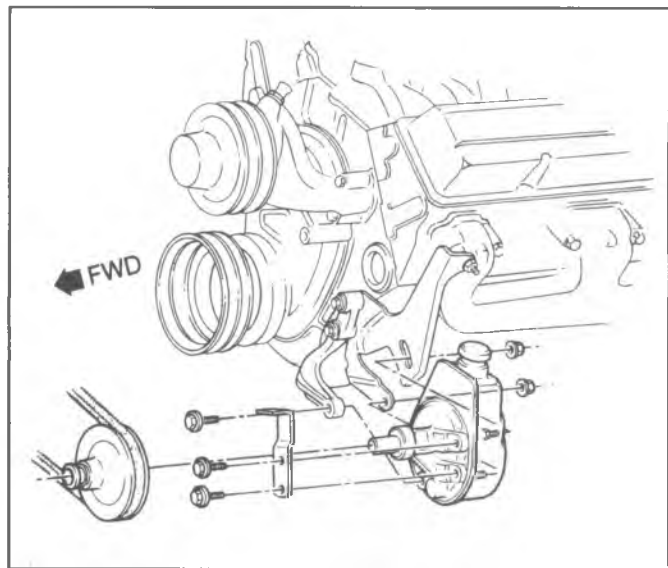

Fig. 3B3-15--P/S Pump Mounting; G100, G200, G300-LE9, LF3, LS9, LT9, N40

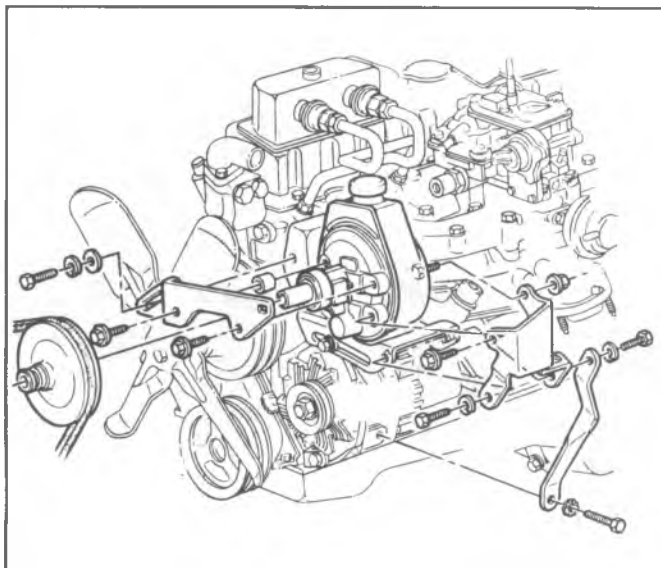

Fig. 3B3-13--P/S Pump Mounting; G100, G200, G300-LE3, NA5

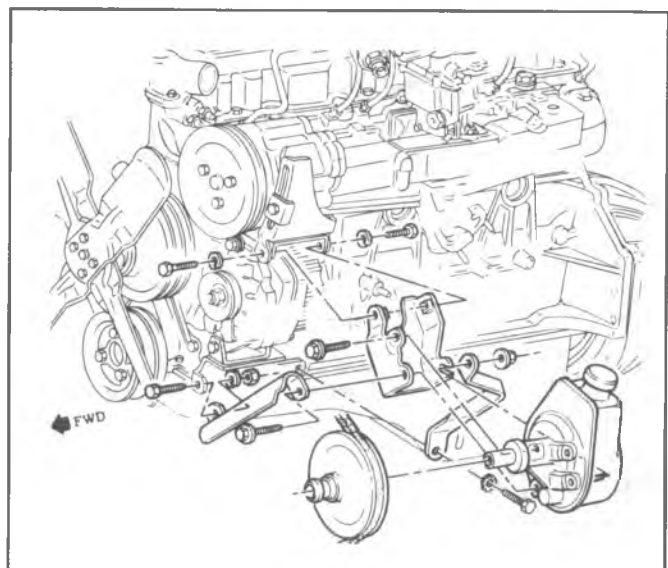

Fig. 3B3-16--P/S Pump Mounting; P200, P300 (42) with L25 Engine



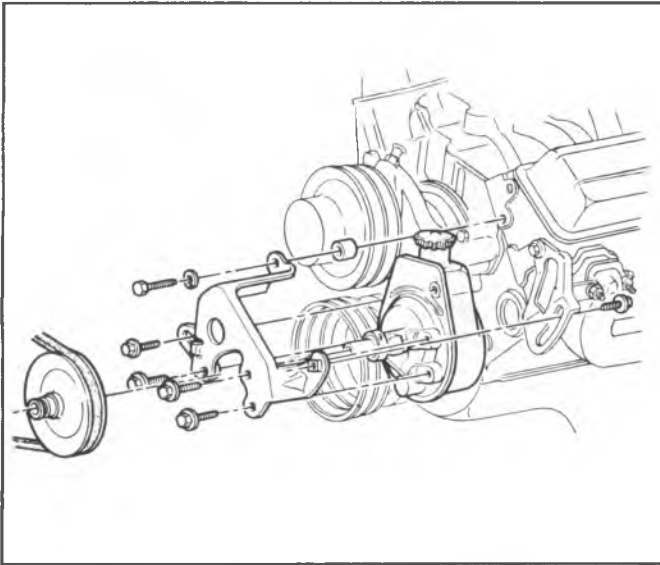

Fig. 3B3-17--P/S Pump Mounting, P200, P300 (42) with LT9

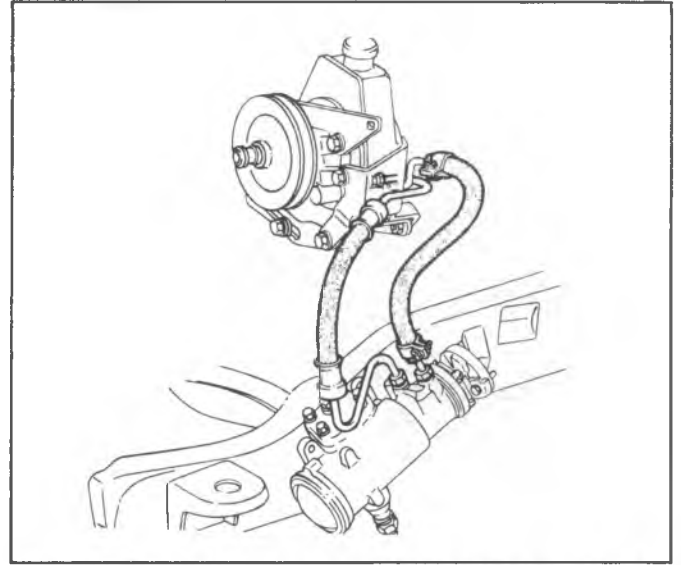

Fig. 3B3-20--P/S Hose Routing; CK100, CK200 (03) with LE3

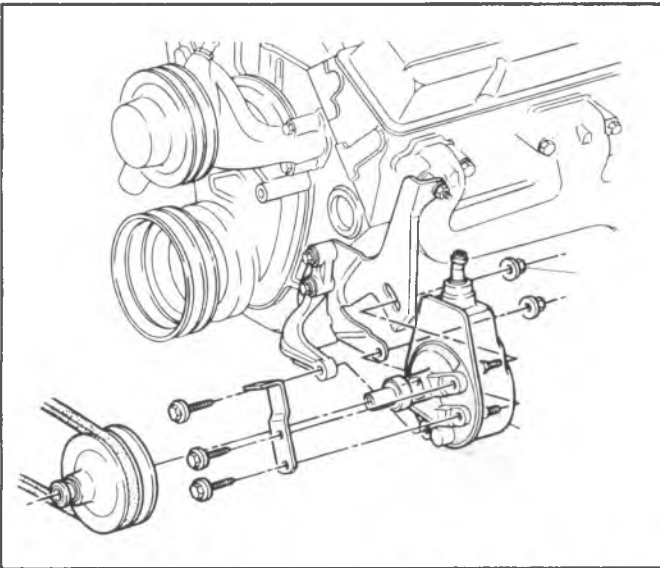

Fig. 3B3-18--P/S Pump Mounting; P200, P300 (32) with LT9 Engine

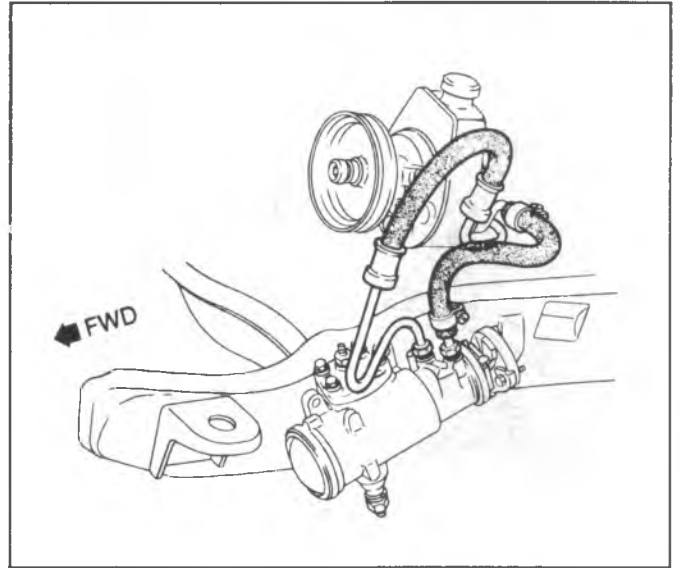

Fig. 3B3-21--P/S Hose Routing; CK200, CK300-L25

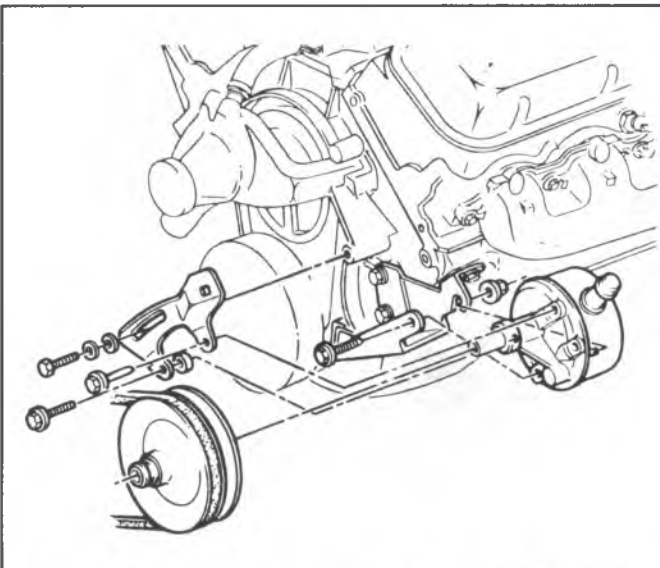

Fig. 3B3-19--P/S Pump Mounting; P300 (32) with LE8 Engine

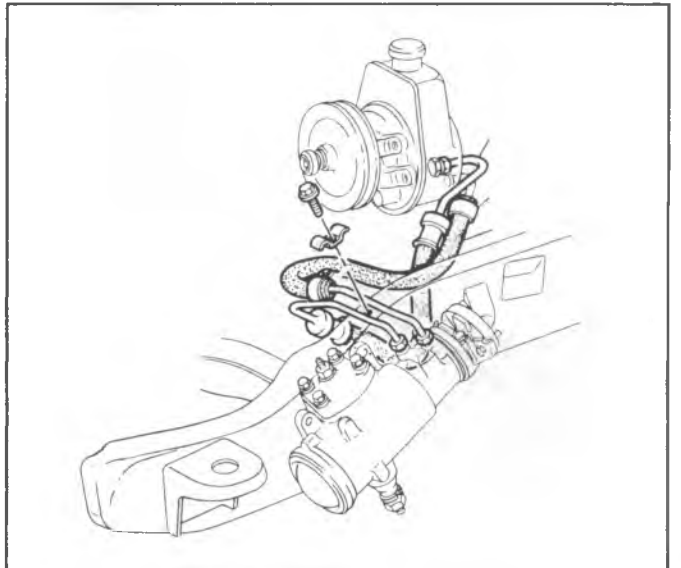

Fig. 3B3-22--P/S Hose Routing, CK100, CK200, CL300-LE9, LF3, LS9, LT9 (Exc. C60, JB8)

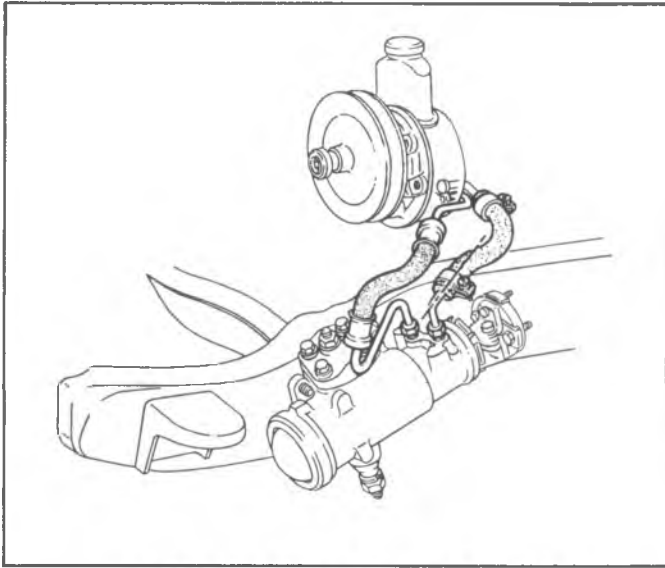

Fig. 3B3-23--P/S Hose Routing; C200-LE8

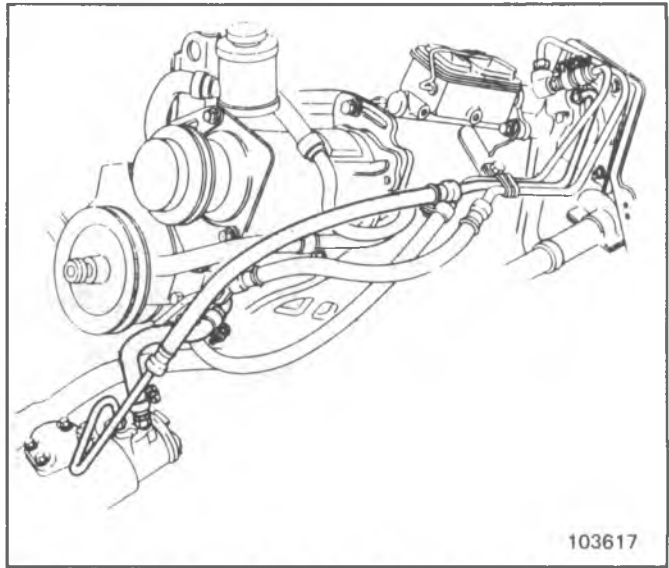

Fig. 3B3-26--P/S Hose Routing, CK100, CK200, CK300-LHG/LL4 (Exc. C60)

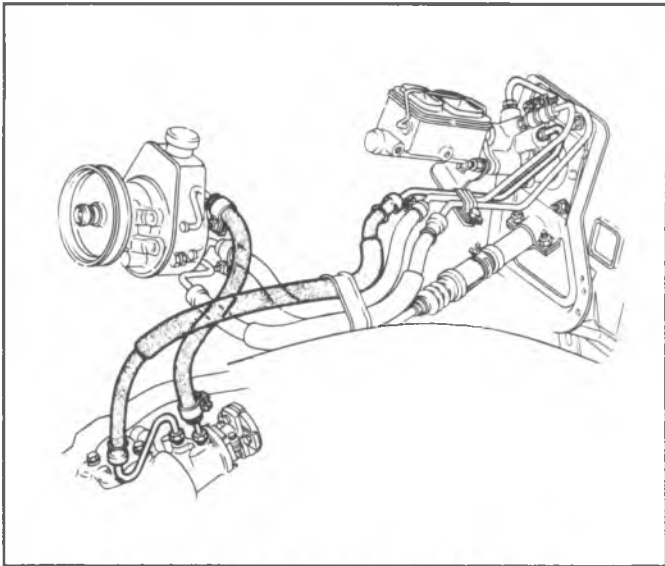

Fig. 3B3-24--P/S Hose Routing; CK300-L25

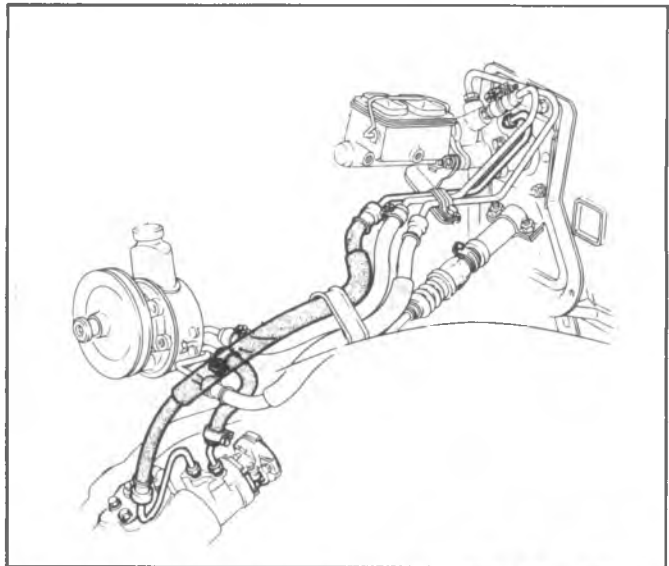

Fig. 3B3-27--P/S Hose Routing; C300-LE8 JB8 (Exc. HC4)

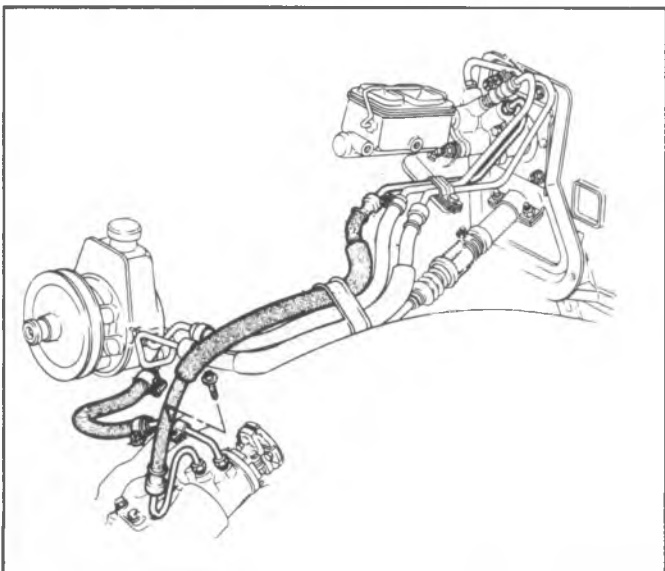

Fig. 3B3-25--P/S Hose Routing; CK300-LF5, LT9, LE8

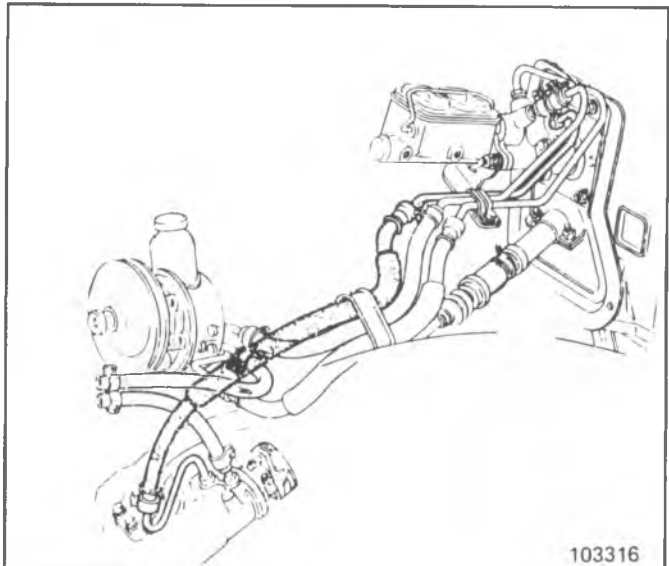

Fig. 3B3-28--P/S Hose Routing; CK300-LE3, HC4



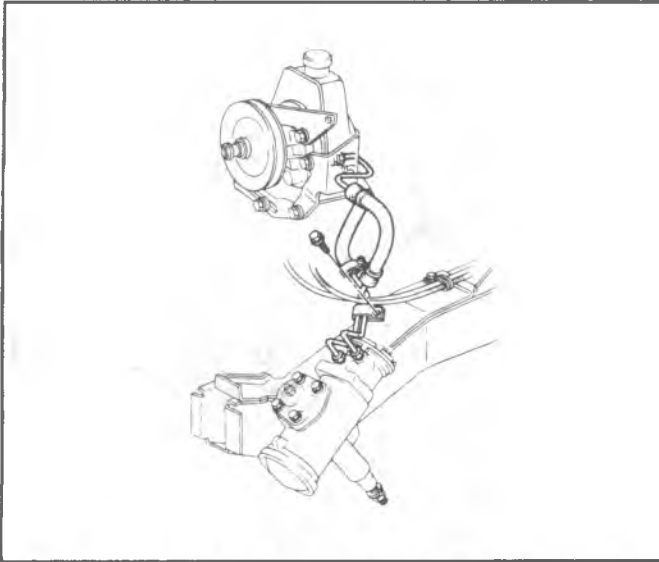

Fig. 3B3-29--P/S Hose Routing, G100, G200, G300-LE3

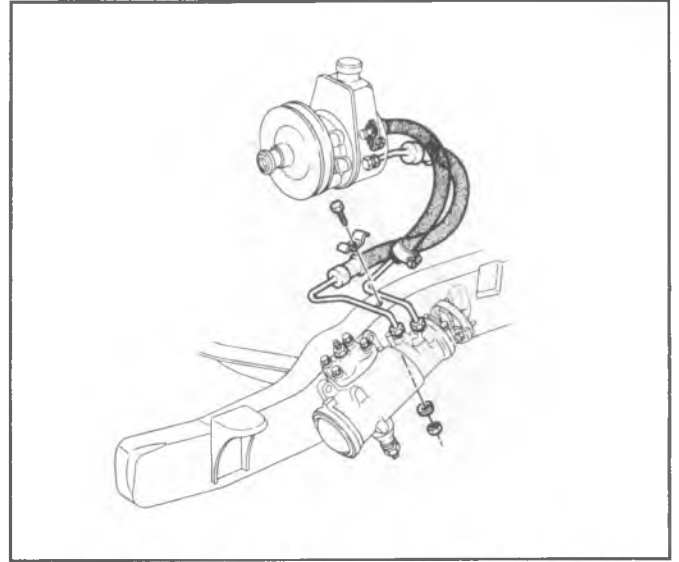

Fig. 3B3-32--P/S Hose Routing; P200-L25 (Exc. JB8/JF9)

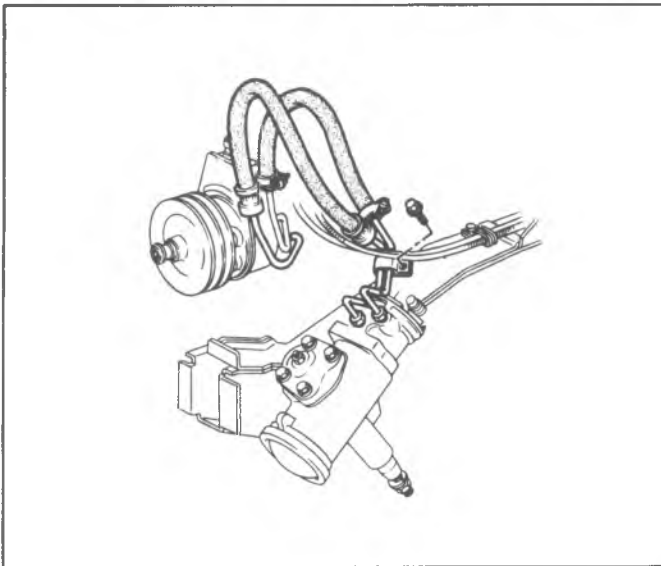

Fig. 3B3-30--P/S Hose Routing; G100, G200, G300-LE4, LG9, LF4, LS9, LT9, JB7

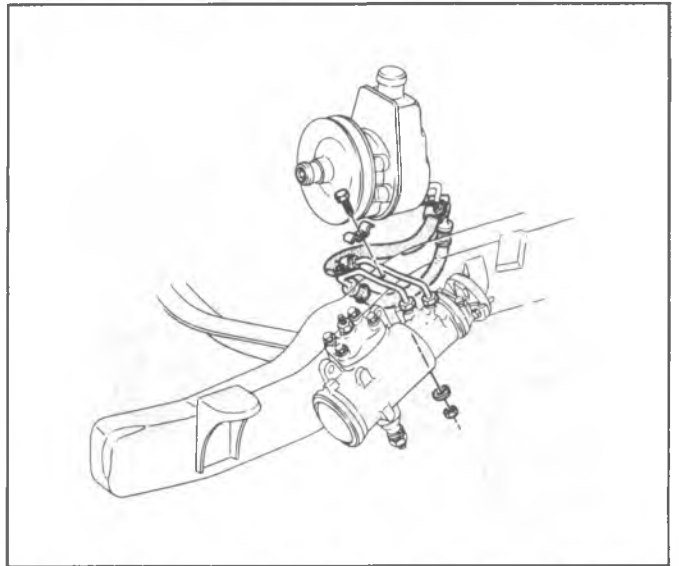

Fig. 3B3-33--P/S Hose Routing; P200, P300 (42)-LT9 (Exc. JB8/JD7/JF9)

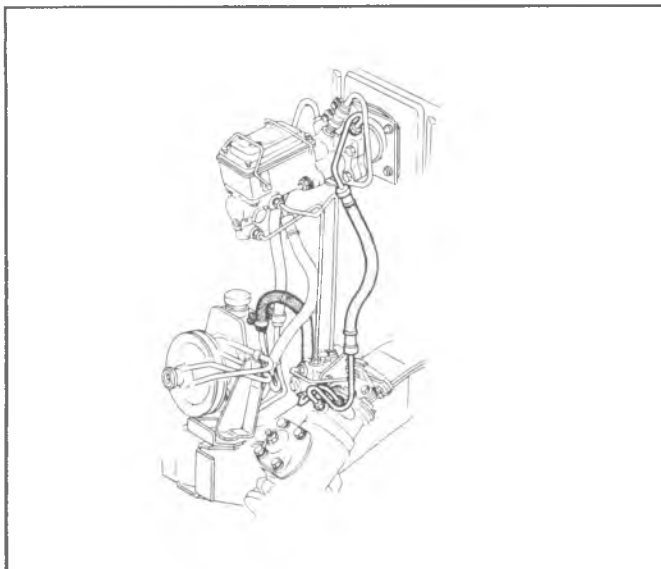

Fig. 3B3-31--P/S Hose Routing; G300-LE4, LG9, LT9

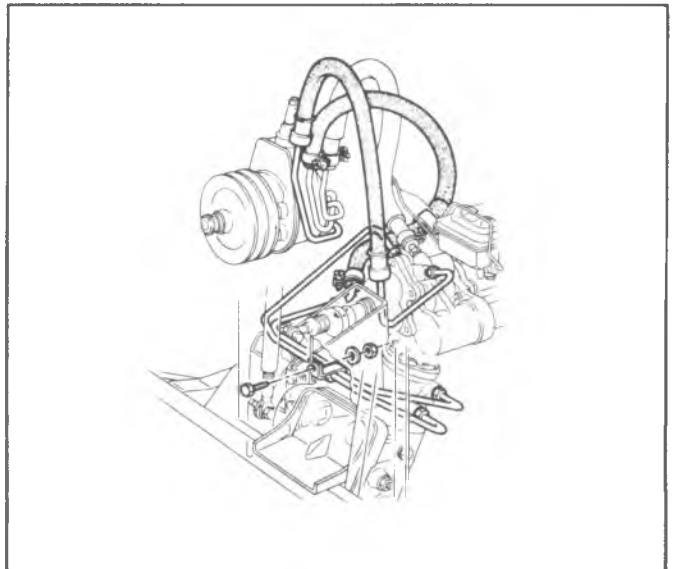

Fig. 3B3-34--P/S Hose Routing; P300 (42)-LT9

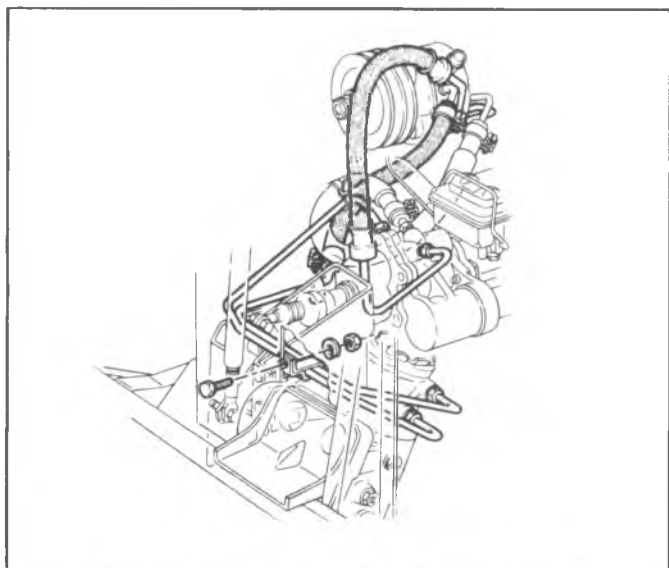

Fig. 3B3-35--P/S Hose Routing; P300 (32)-LE8

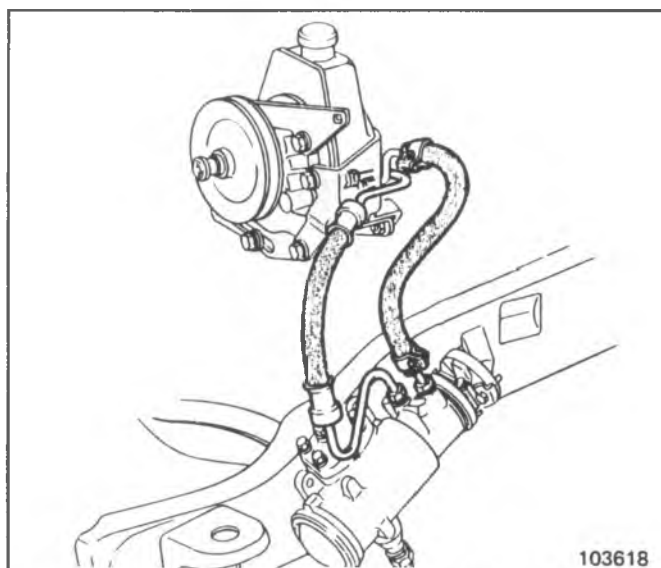

Fig. 3B3-37--P/S Hose Routing; P300 (42) LT9, JB8/JD7/JD9

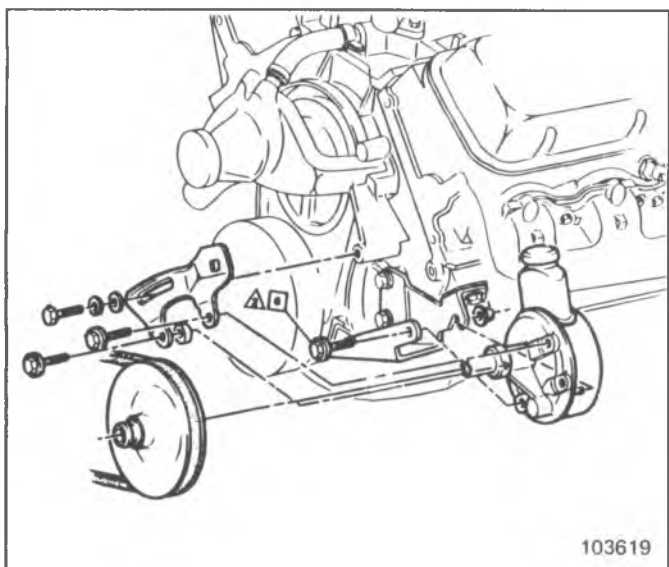
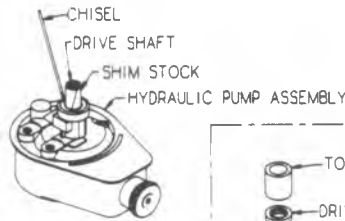

Fig. 3B3-36--P/S Hose Routing; P300-L25, JB8/JF9

**1. REMOVE AND INSTALL DRIVE SHAFT SEAL WITHOUT DISASSEMBLING THE PUMP.**

**REMOVE**

1. PROTECT DRIVE SHAFT WITH SHIM STOCK.
2. USE CHISEL TO CUT SEAL AND REMOVE.



**INSTALL**

1. COAT DRIVE SHAFT SEAL WITH HYDRAULIC PUMP FLUID. REFER TO INSET FOR DRIVE SHAFT SEAL INSTALLATION.

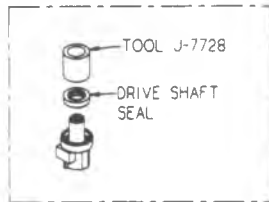

INSTALL DRIVE SHAFT SEAL.

**2. REMOVE AND INSTALL PUMP RESERVOIR ASSEMBLY**

**REMOVE**

1. DRAIN OIL FROM RESERVOIR ASSEMBLY BEFORE REMOVAL.
2. REMOVE PARTS AS SHOWN.

**INSTALL**

1. USE ALL NEW SEALS AND LUBRICATE WITH POWER STEERING FLUID BEFORE INSTALLATION.
2. INSTALL PARTS AS SHOWN.

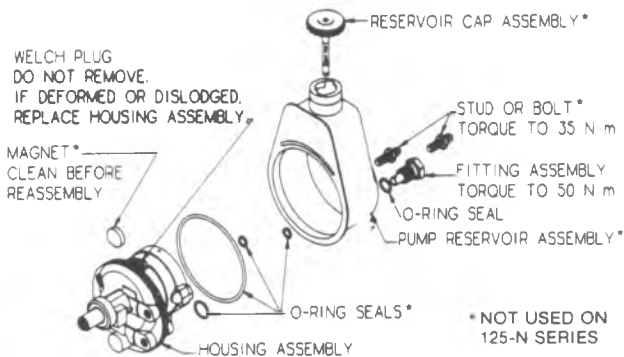

\* NOT USED ON 125-N SERIES

**3. REMOVE AND INSTALL END PLATE.**

**REMOVE**

1. REFER TO INSET FOR RETAINING RING REMOVAL.



REMOVE RETAINING RING

**INSTALL**

1. LUBRICATE END PLATE AND RETAINING RING. INSTALL PARTS AS SHOWN. REFER TO INSET FOR POSITIONING OF RETAINING RING IN HOUSING.



POSITIONING OF RETAINING RING.

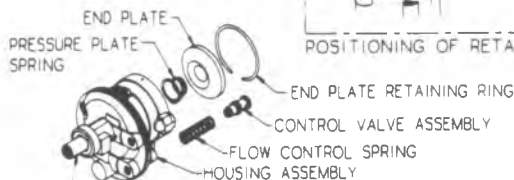

NOTICE BEFORE PROCEEDING. EXAMINE THIS PART OF THE DRIVE SHAFT. IF IT IS CORRODED, CLEAN WITH CROCUS CLOTH BEFORE REMOVING. THIS WILL PREVENT DAMAGE TO THE SHAFT BUSHING WHICH MIGHT REQUIRE REPLACEMENT OF THE ENTIRE HOUSING.

**4. REMOVE AND INSTALL ROTATING GROUP.**

**REMOVE**

1. USING A RUBBER Mallet, TAP LIGHTLY ON DRIVE SHAFT UNTIL PRESSURE PLATE IS FREE.
2. REMOVE RETAINING RING FROM DRIVE SHAFT AND DISCARD. REMOVE PARTS AS SHOWN.

**INSTALL**

1. INSTALL PARTS AS SHOWN ON DRIVE SHAFT. INSTALL NEW RETAINING RING ON DRIVE SHAFT AND INSTALL IN PUMP HOUSING.
2. REFER TO INSET FOR POSITIONING OF PUMP RING IN HOUSING.

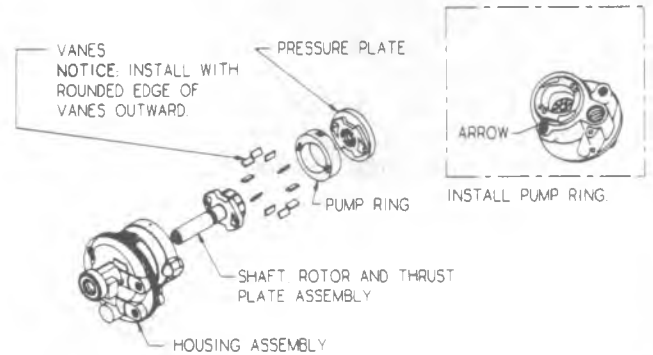

INSTALL PUMP RING

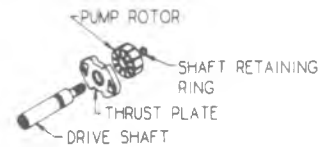

RETAINING RING REMOVAL

**5. REMOVE AND INSTALL DRIVE SHAFT AND O-RING SEALS.**

**REMOVE**

1. REMOVE PARTS AS SHOWN.



INSTALL DRIVE SHAFT SEAL

**INSTALL**

1. REFER TO THE INSET FOR DRIVE SHAFT SEAL INSTALLATION. USE ALL NEW SEALS AND LUBRICATE SEALS WITH POWER STEERING FLUID BEFORE INSTALLATION.
2. INSTALL PARTS AS SHOWN.

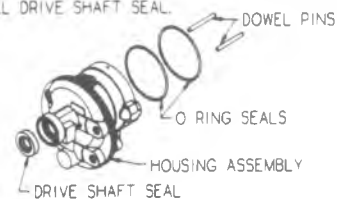

Fig. 3B3-38--Power Steering Pump Overhaul

## POWER STEERING GEAR (605 MODEL)

### GENERAL DESCRIPTION

This Integral Power Steering Gear has a control valve which directs oil to either side of the rack piston. The rack piston converts hydraulic power into mechanical force. This force is transmitted to the mating pitman shaft teeth, through the pitman shaft to the steering linkage.

This is a small design steering gear. To determine this gear from our large steering gear see difference in side cover below.

**NOTE:** Whenever a part which forms a sealing surface for an "O" ring seal is removed, the "O" ring seal should also be removed and replaced with a new seal. Whenever one of the Pitman shaft or stub shaft seals are removed all adjacent seals should be removed and replaced with new seals. Lubricate all new seals with power steering fluid to ease assembly.

Round side cover — held in place with retaining ring



(605 MODEL)

- | Key No. | Part Name                           |
|---------|-------------------------------------|
| 1       | HOUSING, STEERING GEAR              |
| 2       | RETAINER STRG COUPLING SHIELD       |
| 3       | BEARING ASSY. NEEDLE (STUB SHAFT)   |
| 4       | SEAL, STUB SHAFT                    |
| 5       | SEAL, STUB SHAFT DUST               |
| 6       | RING, RETAINING (STUB SHAFT SEAL)   |
| 7       | BEARING ASSY. NEEDLE (PITMAN SHAFT) |
| 8       | SEAL PITMAN SHAFT                   |
| 9       | WASHER, SEAL BACK-UP (PITMAN SHAFT) |
| 10      | SEAL, PITMAN SHAFT DUST             |
| 11      | RING, RETAINING (PITMAN SHAFT SEAL) |
| 12      | WASHER LOCK (PITMAN SHAFT)          |
| 13      | NUT, PITMAN ARM                     |
| 14      | BEARING ASSY. RACE & UPPER          |
| 15      | RING, VALVE BODY (3)                |
| 16      | SEAL, "O" RING (VALVE BODY) (3)     |
| 17      | BODY ASSY. VALVE                    |
| 18      | SEAL, "O" RING (DAMPNER)            |
| 19      | SPOOL, VALVE                        |

- | Key No. | Part Name                        |
|---------|----------------------------------|
| 20      | SHAFT ASSY. STUB                 |
| 21      | SEAL, "O" RING (SHAFT TO WORM)   |
| 22      | WORM ASSY., PIN & STRG           |
| 23      | RING, RETAINING (SHAFT TO WORM)  |
| 24      | RING, RACK PISTON                |
| 25      | SEAL, "O" RING (RACK PISTON)     |
| 26      | RACK PISTON-NUT                  |
| 27      | BEARING ASSY., SUPPORT & LWR THR |
| 28      | SEAL, "O" RING (ADJUSTER PLUG)   |
| 29      | PLUG, ADJUSTER                   |
| 30      | NUT, ADJUSTER LOCK               |
| 31      | SPRING, SIDE COVER               |
| 32      | SEAL, "O" RING (ADJUSTER PLUG)   |
| 33      | GEAR ASSY., PITMAN SHAFT         |
| 34      | COVER ASSY. HOUSING SIDE         |
| 35      | RING, RETAINING (SIDE COVER)     |
| 36      | NUT, PRELOAD ADJUSTER SEALING    |
| 37      | CONNECTOR, INVERTED FLARE (2)    |

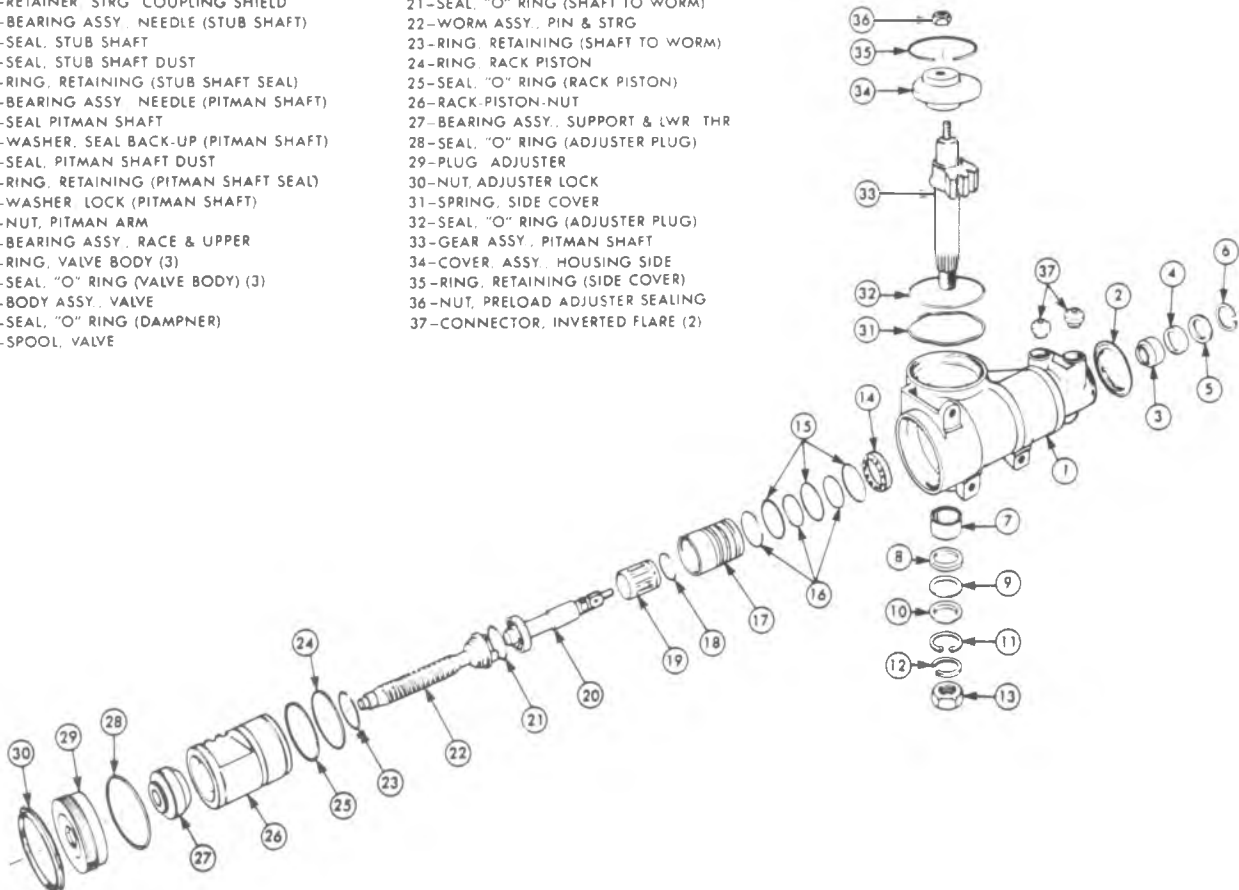

Fig. 3B3-39--Overhaul 605 Gear, Chart A

### 1. REMOVE AND INSTALL PITMAN SHAFT SEALS IN CAR

#### REMOVE

1. Clean exposed end of pitman shaft and end of housing after removing arm.
2. Remove retaining ring.
3. Start engine and turn wheels fully to the right to force seals and washer out.
4. Turn off engine.
5. Inspect housing and shaft.

**PITMAN SHAFT** — Inspect seal surface for roughness and pitting.

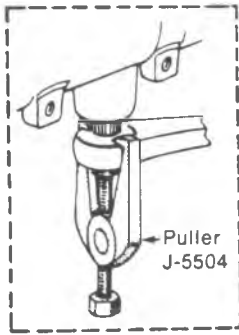

Remove Pitman Arm

#### INSTALL

1. Install parts as shown. Inspect for burrs.

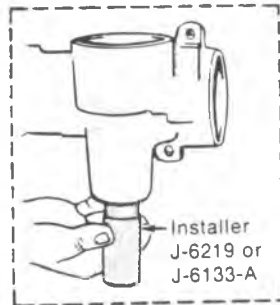
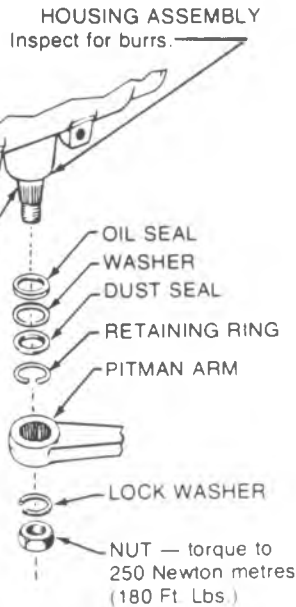

Install Seals

### 2. REMOVE AND INSTALL STUB SHAFT SEALS WITHOUT DISASSEMBLING GEAR

#### REMOVE

1. Remove retaining ring and dust seal. Take care not to scratch shaft.
2. Wrap 0.1mm to 0.2mm (.005" to .008") shim stock around shaft and insert between shaft and sealing lip until it bottoms. Pry seal out.\*

#### INSTALL

1. Install stub shaft seal. Liberally coat top of seal with anhydrous calcium grease.
2. Install dust seal just deep enough to clear retaining ring groove, then install retaining ring.

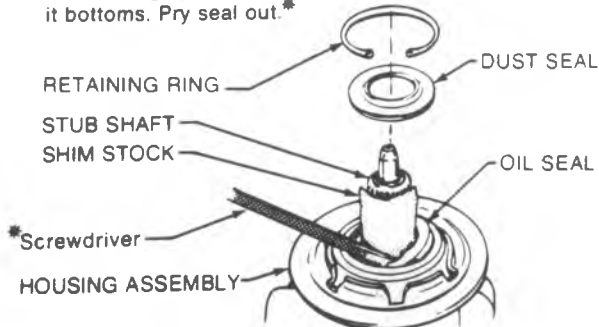

### 3. REMOVE AND INSTALL PITMAN SHAFT AND SIDE COVER

#### REMOVE

1. If pitman shaft and side cover are to be separated, remove preload adjuster nut. IT IS A LEFT HAND THREAD.
2. Rotate stub shaft to center gear, then remove parts as shown. Tap on thread end of pitman shaft with plastic hammer.

#### INSTALL

1. Install parts as shown. Use new retaining ring, make sure that open end of retaining ring is approx. 13mm (1/2") from access hole.
2. Depress side cover to make sure retaining ring seats properly.

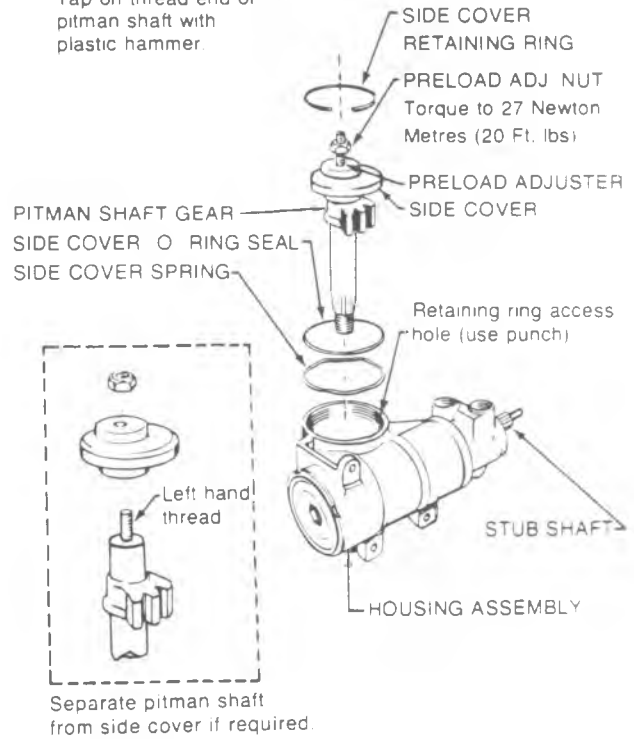

### 4. REMOVE AND INSTALL LOWER BEARING AND ADJUSTER

#### REMOVE

1. Loosen lock nut. Use punch against edge of one slot.
2. Remove parts as shown.
3. Inspect lower thrust bearing assembly.

#### INSTALL

1. Install parts as shown.
2. Adjust thrust bearing preload (see adjustment procedure) before tightening lock nut.

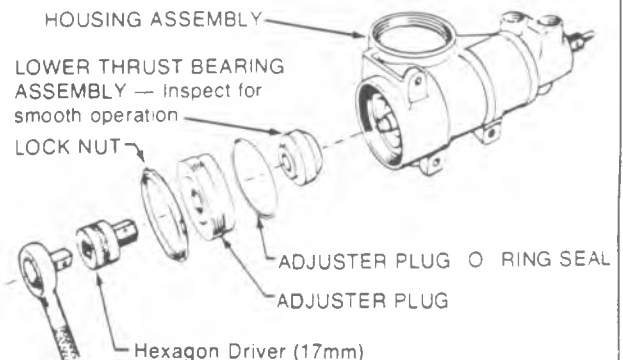

Fig. 3B3-40--Overhaul 605 Gear, Chart B

**5. REMOVE AND INSTALL RACK PISTON AND VALVE ASSEMBLY**

**REMOVE**

1. Remove parts as shown. Push on stub shaft. DO NOT remove upper bearing assembly (see stub shaft seal removal)

**INSTALL**

1. Install parts as shown. Make sure rack piston teeth are positioned toward side cover opening.

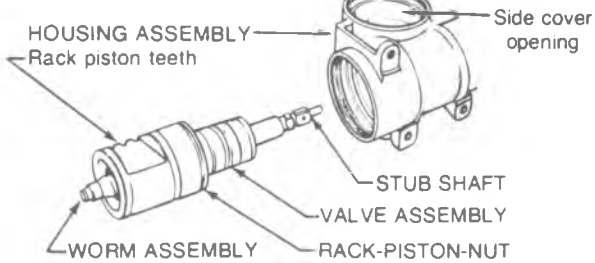

**6. REMOVE AND INSTALL VALVE AND WORM ASSEMBLY FROM RACK PISTON**

**REMOVE**

1. Unscrew valve and worm from rack.
2. Remove teflon ring and rack piston "O" ring from rack piston.

**INSTALL**

1. Install "O" ring and teflon ring as shown.
2. Screw worm and valve into rack piston. See procedure below.

**VALVE AND WORM ASSEMBLY**

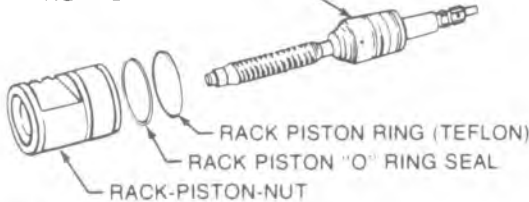

**A. Assemble worm and valve to rack piston**

1. Hold rack teeth and worm drive pin in relation shown with light pressure to hold worm thread against piston.
2. Turn worm and valve counterclockwise slowly until one "Click" is felt.

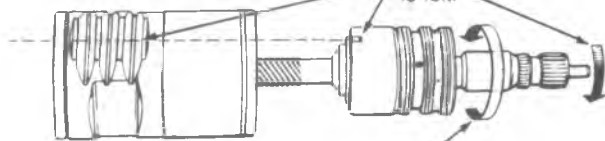

3. Turn worm and valve clockwise to complete assembly.

**B. Check relation of stub shaft and rack piston**

1. Screw worm and valve into rack piston until valve face and rack piston face are flush.

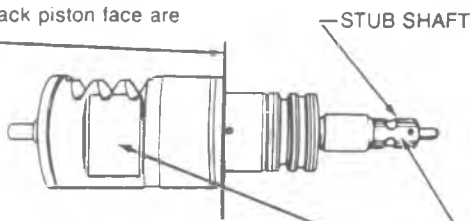

2. With rack piston in position shown, flats on stub shaft and piston are to be parallel. If not parallel, disassemble and repeat "A." above.

**7. REMOVE AND INSTALL VALVE ASSEMBLY FROM WORM ASSEMBLY**

**REMOVE**

1. Remove parts as shown.

**INSTALL**

1. Install parts as shown. See below.

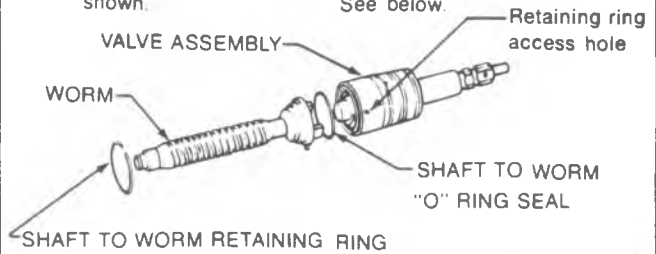

**Assemble worm to valve**

RETAINING RING — Install with "curved in end" on same side as access hole.



**8. DISASSEMBLE AND ASSEMBLE VALVE**

**DISASSEMBLE**

1. Disassemble parts as shown.

**ASSEMBLE**

2. Assemble parts as shown.

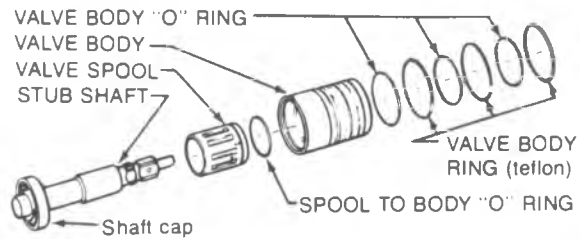

**A. Loosen shaft cap**



**B. Remove and install stub shaft.**

Pull cap out approx. 6 mm (1/4")

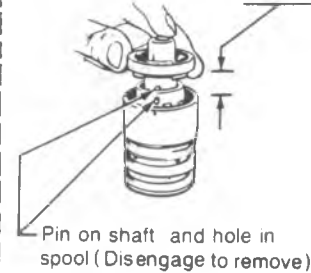

**C. Remove and install spool**



Lubricate spool and body with power steering fluid.

**D. Engage stub shaft**

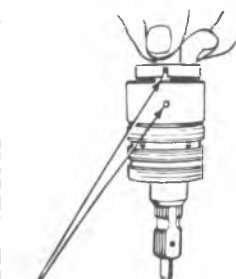

Notch must fully engage pin and cap must seat against shoulder.

Fig. 3B3-41--Overhaul 605 Gear, Chart C

### 9. REMOVE AND INSTALL STUB SHAFT SEALS AND BEARINGS

**REMOVE**

1. Clean end of housing to prevent dirt from entering gear.
2. Remove parts as shown, being careful not to score housing bore.
3. Remove stub shaft needle bearing and upper thrust bearing if required. Put a finger into the stub shaft cavity and hook it onto the upper thrust bearing race. Turn the race while pulling up. If bearing operation is smooth, it does not need removal. Check the stub shaft needle bearing for smoothness. If O.K., do not remove.

**INSTALL**

1. If removed, install new stub shaft needle bearing. Bottom tool on housing counterbore. **NOTE: SERVICE thrust bearing DOES NOT SNAP ON needle bearing** If removed, install as shown below.
2. Install stub shaft seal. Liberally coat top of seal with anhydrous calcium grease.
3. Install dust seal just deep enough to clear retaining ring groove, then install retaining ring.

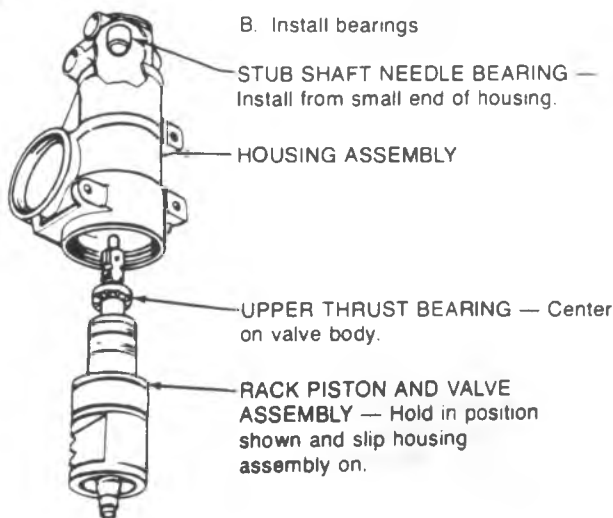
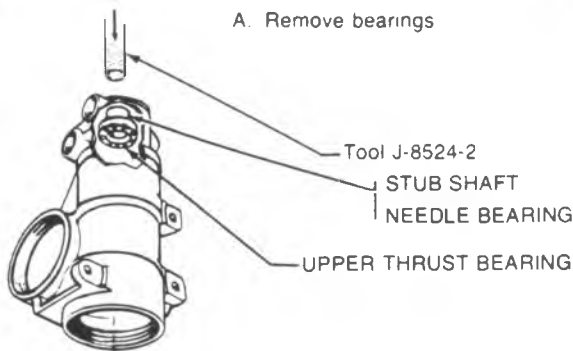
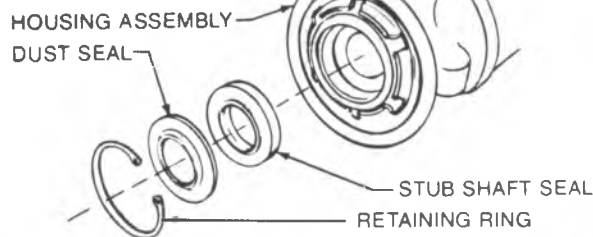

### 10. REMOVE AND INSTALL PITMAN SHAFT SEALS AND BEARING

**REMOVE**

1. Remove parts as shown **CAUTION: Do not damage housing bore**

**INSTALL**

1. Bottom oil seal in counterbore. Install washer. Coat seal lip and washer face with anhydrous calcium grease.
2. Install remaining parts as shown.

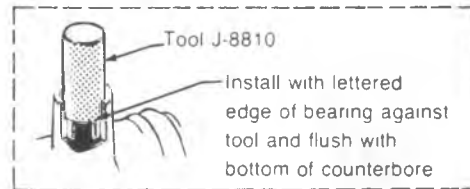
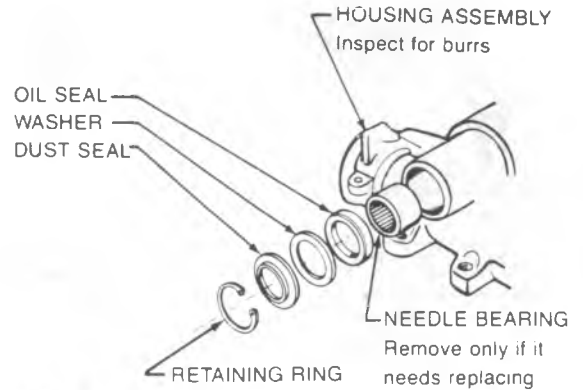

Remove and install bearing (not necessary unless bearing is to be replaced)

### 11. REMOVE AND INSTALL CONNECTORS

**REMOVE**

1. Remove Parts As Shown

**INSTALL**

1. Install Parts As Shown

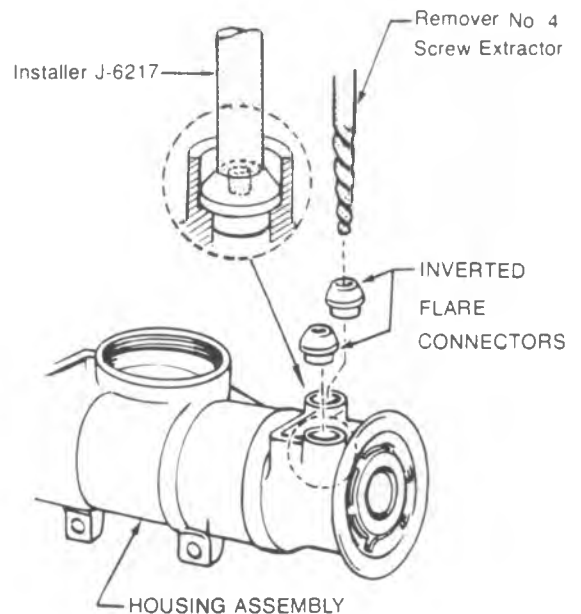
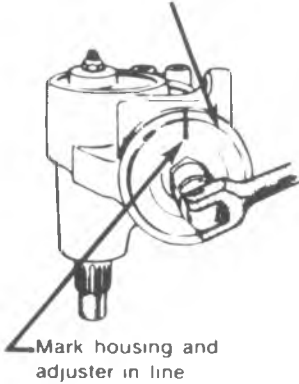

Fig. 3B3-42--Overhaul 605 Gear, Chart D

### 12. ADJUST WORM BEARING PRELOAD

A Tighten adjuster plug until it bottoms (use 17mm hex. driver). Torque to approx. 40 Newton meters (30 ft. lbs.)



B Measure 13mm (½") counter-clockwise and mark housing only

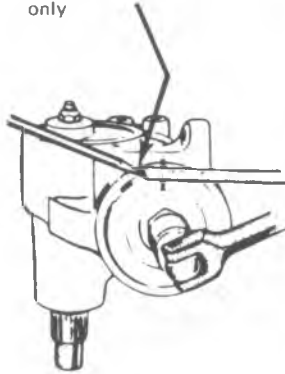

C Turn adjuster back until mark lines up with second mark on housing

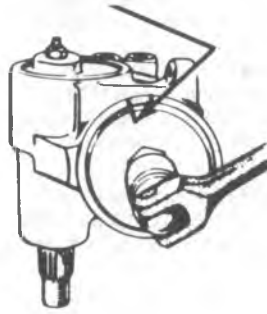

D Tighten lock nut. Use punch in notch



### 13. ADJUST "OVER CENTER" PRELOAD

A. Whenever a power steering gear requires adjustment, the gear should be drained of hydraulic fluid.



To drain the fluid, position the assembly with hydraulic line ports pointing downward over a container and cycle the rack-piston-nut from stop to stop three or four times.

B. When a unit has been disassembled for any reason, the side cover must be firmly seated against its retaining ring before any adjustment is attempted.

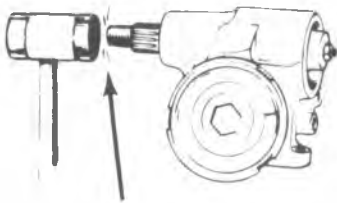

To seat the side cover, tap on the end of the pitman shaft with a soft hammer.

C. Back off preload adjuster (LEFT HAND THREAD) until it stops, then turn it in one full turn.

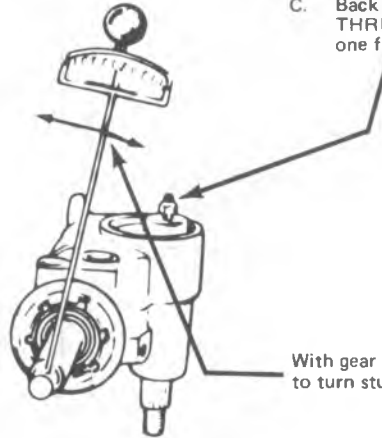

With gear at center of travel, check torque to turn stub shaft (reading No. 1)

D. Turn adjuster in until torque to turn stub shaft is 0.6 to 1.2 Newton meters (6 to 10 in. lbs.) more than reading No. 1.



Torque adjuster lock nut to 27 Newton meters (20 ft. lbs.) Prevent adjuster screw from turning while torquing lock nut.

### SPECIAL TOOLS

- |           |   |         |   |
|-----------|---|---------|---|
| J-4245    | — Snap Ring Pliers                                  | J-8058  | — 0-125 Newton-meter Torque Wrench (0-50 foot-pounds) |
| J-29107   | — Pitman Arm Puller                                 | J-8810  | — Pitman Shaft Bearing Remover And Installer          |
| J-6133-01 | — Pitman Shaft Seal Installer                       | J-25323 | — Power Steering Analyzer                             |
| J-6217    | — Connector Seat Installer                          |         |   |
| J-7754    | — 0-5 Newton-meter Torque Wrench (0-25 inch-pounds) |         |   |

Fig. 3B3-43--Overhaul 605 Gear, Chart E



## POWER STEERING GEAR (800 MODEL)

### GENERAL DESCRIPTION

These Integral Power Steering Gears have a control valve which directs oil to either side of the rack piston. The rack piston converts hydraulic power into mechanical force. This force is transmitted to the mating pitman shaft teeth, through the pitman shaft to the steering linkage.

The model 800 incorporates a recirculating ball system in which steel balls act as a rolling thread between a steering worm-shaft and the rack-piston.

Repair procedures for these two models are different. Note the side cover differences in the sketch below.

Whenever a part which forms a sealing surface for an "O" ring is removed, the "O" ring seal should also be removed and replaced with a new seal. Whenever one of the Pitman shaft or stub shaft seals are removed all adjacent seals should be removed and replaced with new seals. Lubricate all new seals with power steering fluid to ease assembly.



Rectangular side cover held in place with four bolts

(800 MODEL)

| Key No. | Part Name                          | Key No. | Part Name                           | Key No. | Part Name                          |
|---------|------------------------------------|---------|-------------------------------------|---------|------------------------------------|
| 1       | HOUSING, STEERING GEAR             | 19      | PLUG, ADJUSTER                      | 37      | SCREW ASSY, LOCKWASHER & (2)       |
| 2       | RACE, THRUST BEARING (WORM)        | 20      | BEARING, NEEDLE                     | 38      | PLUG RACK PISTON                   |
| 3       | BEARING ASSY, ROLLER THRUST (WORM) | 21      | SEAL, STUB SHAFT                    | 39      | SEAL, "O" RING (RACK PISTON)       |
| 4       | RACE, THRUST BEARING (WORM)        | 22      | SEAL, STUB SHAFT DUST               | 40      | RING, RACK PISTON                  |
| 5       | WORM, STEERING                     | 23      | RING, RETAINING                     | 41      | SEAL, "O" RING (HOUSING END PLUG)  |
| 6       | SEAL, "O" RING (STUB SHAFT)        | 24      | NUT, ADJUSTER PLUG LOCK             | 42      | PLUG, HOUSING END                  |
| 7       | SHAFT, STUB                        | 25      | BEARING ASSY, NEEDLE (PITMAN SHAFT) | 43      | RING, RETAINING (HOUSING END PLUG) |
| 8       | SPOOL, VALVE                       | 26      | SEAL, PITMAN SHAFT (SINGLE LIP)     | 44      | GEAR ASSY, PITMAN SHAFT            |
| 9       | SEAL, "O" RING (SPOOL)             | 27      | WASHER, SEAL BACK-UP (PITMAN SHAFT) | 45      | SEAL ASSY, GASKET                  |
| 10      | BODY, VALVE                        | 28      | SEAL, PITMAN SHAFT (DOUBLE LIP)     | 46      | COVER ASSY, HOUSING SIDE           |
| 11      | RING, VALVE BODY (3)               | 29      | WASHER, SEAL BACK-UP (PITMAN SHAFT) | 47      | BOLT, HEX HEAD (SIDE COVER) (4)    |
| 12      | SEAL, "O" RING (VALVE BODY) (3)    | 30      | RING, RETAINING (PITMAN SHAFT SEAL) | 48      | NUT, LASH ADJUSTER                 |
| 13      | RETAINER, BEARING (ADJUSTER)       | 31      | WASHER, PITMAN SHAFT LOCK           | 49      | SPRING, CHECK VALVE                |
| 14      | SPACER, THRUST BEARING             | 32      | NUT, PITMAN SHAFT                   | 50      | POPPET CHECK VALVE                 |
| 15      | RACE, UPPER THRUST BEARING (SMALL) | 33      | NUT, RACK PISTON                    | 51      | CONNECTOR INVERTED FLARE           |
| 16      | BEARING, UPPER THRUST              | 34      | BALL                                | 52      | CONNECTOR INVERTED FLARE           |
| 17      | RACE, UPPER THRUST BEARING (LARGE) | 35      | GUIDE, BALL RETURN (2)              |         |                                    |
| 18      | SEAL, "O" RING (ADJUSTER)          | 36      | CLAMP, BALL RETURN GUIDE            |         |                                    |

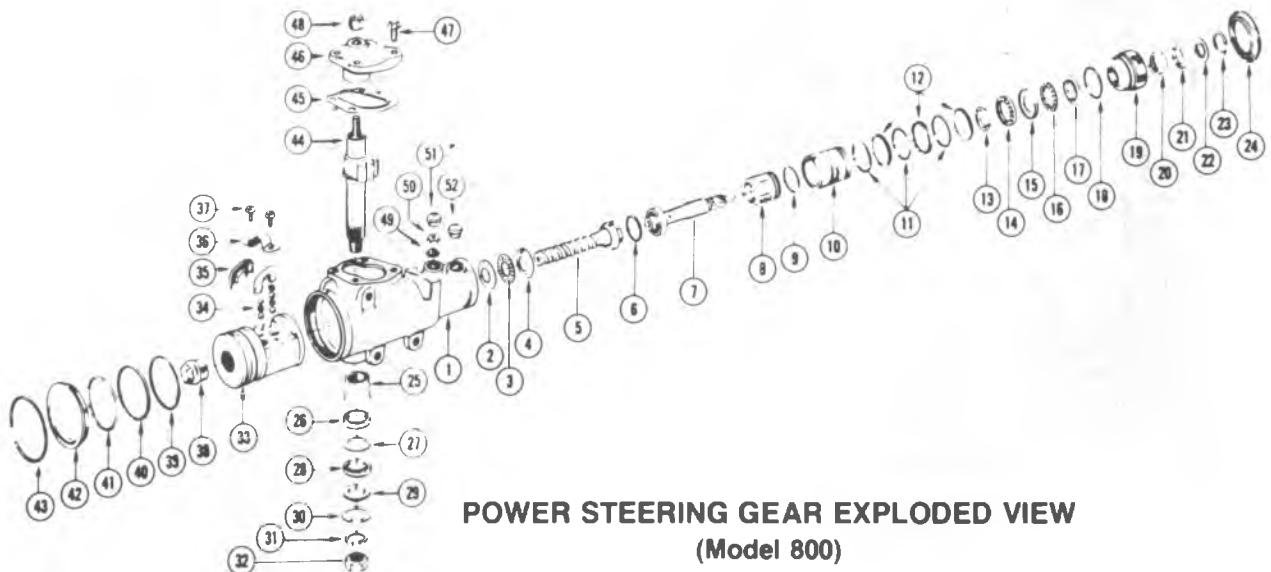

POWER STEERING GEAR EXPLODED VIEW  
(Model 800)

Fig. 3B3-44--Overhaul 800/808 Gear, Chart A

- | Key No. | Part Name                           |
|---------|-------------------------------------|
| 1       | HOUSING, STEERING GEAR              |
| 2       | RACE, THRUST BEARING (WORM)         |
| 3       | BEARING ASSY., ROLLER THRUST (WORM) |
| 4       | RACE, THRUST BEARING (WORM)         |
| 5       | WORM, STEERING                      |
| 6       | SEAL, "O" RING (STUB SHAFT)         |
| 7       | SHAFT, STUB                         |
| 8       | SPOOL, VALVE                        |
| 9       | SEAL, "O" RING (SPOOL)              |
| 10      | BODY, VALVE                         |
| 11      | RING, VALVE BODY (3)                |
| 12      | SEAL, "O" RING (VALVE BODY) (3)     |
| 13      | RETAINER, BEARING (ADJUSTER)        |
| 14      | SPACER, THRUST BEARING              |
| 15      | RACE, UPPER THRUST BEARING (SMALL)  |
| 16      | BEARING, UPPER THRUST               |
| 17      | RACE, UPPER THRUST BEARING (LARGE)  |
| 18      | SEAL, "O" RING (ADJUSTER)           |

- | Key No. | Part Name                            |
|---------|--------------------------------------|
| 19      | PLUG, ADJUSTER                       |
| 20      | BEARING, NEEDLE                      |
| 21      | SEAL, STUB SHAFT                     |
| 22      | SEAL, STUB SHAFT DUST                |
| 23      | RING, RETAINING                      |
| 24      | NUT, ADJUSTER PLUG LOCK              |
| 25      | BEARING ASSY., NEEDLE (PITMAN SHAFT) |
| 26      | SEAL, PITMAN SHAFT (SINGLE LIP)      |
| 27      | WASHER, SEAL BACK-UP (PITMAN SHAFT)  |
| 28      | SEAL, PITMAN SHAFT (DOUBLE LIP)      |
| 29      | WASHER, SEAL BACK-UP (PITMAN SHAFT)  |
| 30      | RING, RETAINING (PITMAN SHAFT SEAL)  |
| 31      | WASHER, PITMAN SHAFT LOCK            |
| 32      | NUT, PITMAN SHAFT                    |
| 33      | NUT, RACK PISTON                     |
| 34      | BALL                                 |
| 35      | GUIDE, BALL RETURN (2)               |
| 36      | CLAMP, BALL RETURN GUIDE             |

- | Key No. | Part Name                          |
|---------|------------------------------------|
| 37      | SCREW ASSY., LOCKWASHER & (2)      |
| 38      | PLUG, RACK PISTON                  |
| 39      | SEAL, "O" RING (RACK PISTON)       |
| 40      | RING, RACK PISTON                  |
| 41      | SEAL, "O" RING (HOUSING END PLUG)  |
| 42      | PLUG, HOUSING END                  |
| 43      | RING, RETAINING (HOUSING END PLUG) |
| 44      | GEAR ASSY., PITMAN SHAFT           |
| 45      | SEAL ASSY., GASKET                 |
| 46      | COVER ASSY., HOUSING SIDE          |
| 47      | BOLT, HEX. HEAD (SIDE COVER) (4)   |
| 48      | NUT, LASH ADJUSTER                 |
| 49      | SPRING, CHECK VALVE                |
| 50      | POPPET, CHECK VALVE                |
| 51      | CONNECTOR, INVERTED FLARE          |
| 52      | CONNECTOR, INVERTED FLARE          |
| 53      | BOLT, COUPLING PINCH               |
| 54      | COUPLING, STEERING SHAFT           |



USED ON SOME MODELS

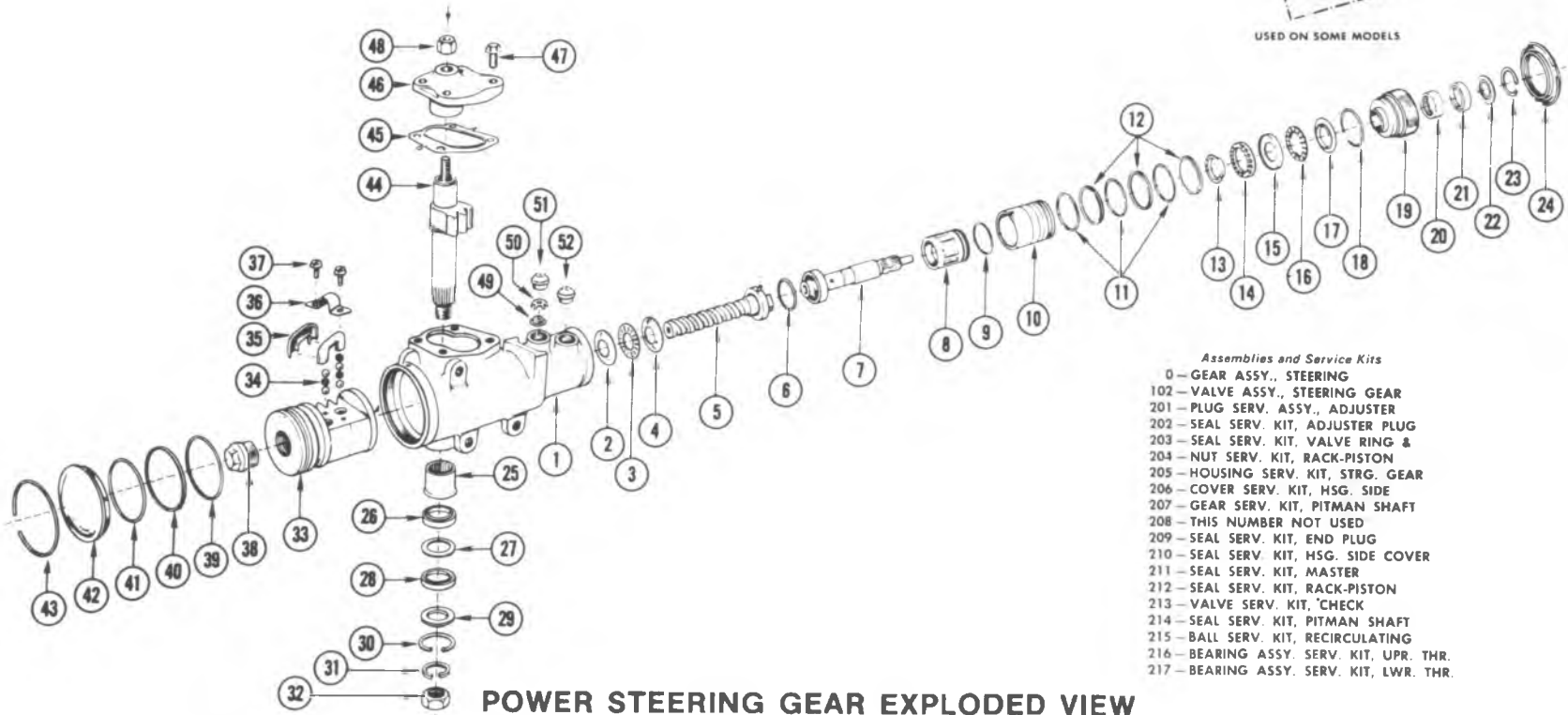

POWER STEERING GEAR EXPLODED VIEW

- Assemblies and Service Kits*
- 0 - GEAR ASSY., STEERING
  - 102 - VALVE ASSY., STEERING GEAR
  - 201 - PLUG SERV. ASSY., ADJUSTER
  - 202 - SEAL SERV. KIT, ADJUSTER PLUG
  - 203 - SEAL SERV. KIT, VALVE RING &
  - 204 - NUT SERV. KIT, RACK-PISTON
  - 205 - HOUSING SERV. KIT, STRG. GEAR
  - 206 - COVER SERV. KIT, HSG. SIDE
  - 207 - GEAR SERV. KIT, PITMAN SHAFT
  - 208 - THIS NUMBER NOT USED
  - 209 - SEAL SERV. KIT, END PLUG
  - 210 - SEAL SERV. KIT, HSG. SIDE COVER
  - 211 - SEAL SERV. KIT, MASTER
  - 212 - SEAL SERV. KIT, RACK-PISTON
  - 213 - VALVE SERV. KIT, CHECK
  - 214 - SEAL SERV. KIT, PITMAN SHAFT
  - 215 - BALL SERV. KIT, RECIRCULATING
  - 216 - BEARING ASSY. SERV. KIT, UPR. THR.
  - 217 - BEARING ASSY. SERV. KIT, LWR. THR.

Fig. 3B3-45--Overhaul 800/808 Gear, Chart B

### 1. REMOVE AND INSTALL PITMAN SHAFT SEALS IN CAR

#### REMOVE

1. Clean exposed end of pitman shaft and end of housing after removing pitman arm.
2. Remove retaining ring with snap ring pliers J-4245.
3. Start engine and turn wheels fully to the left to force seals and washer out.
4. Turn off engine.
5. Inspect housing and shaft.

**PITMAN SHAFT**  
Inspect seal surface for roughness and pitting

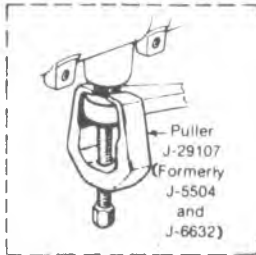

Remove Pitman Arm

#### INSTALL

1. Install parts as shown.

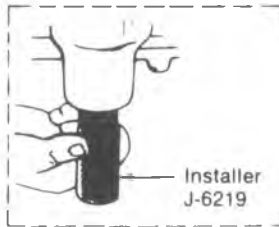
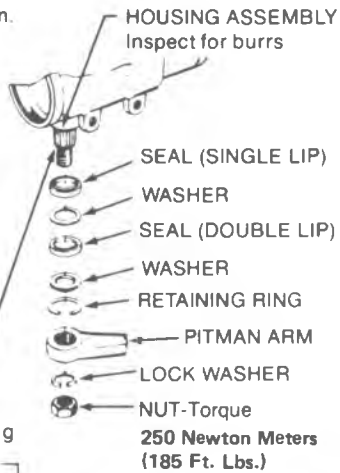

Install Seals

### 2. REMOVE AND INSTALL PITMAN SHAFT AND SIDE COVER

#### REMOVE

1. If pitman shaft and side cover are to be separated, remove preload adjuster nut.
2. Rotate stub shaft to center gear, then remove parts as shown.

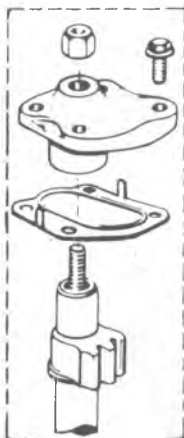

Separate pitman shaft and gasket seal from side cover if required.

#### INSTALL

1. If removed, install gasket seal by bending tabs around cover edges.
2. Install parts as shown.

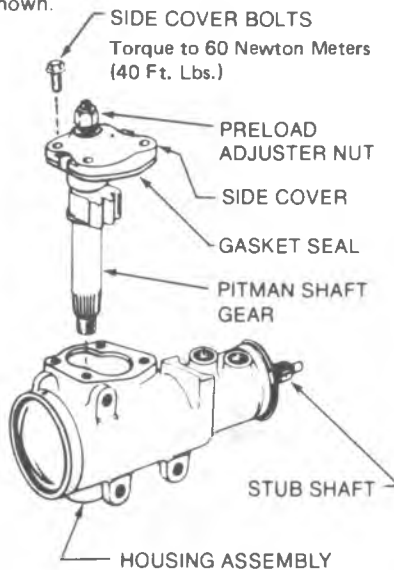

### 3. REMOVE AND INSTALL HOUSING END PLUG

#### REMOVE

1. Remove parts as shown.

#### INSTALL

1. Install parts as shown. Open end of retaining ring to be approx. 25 mm (1 inch) from access hole.

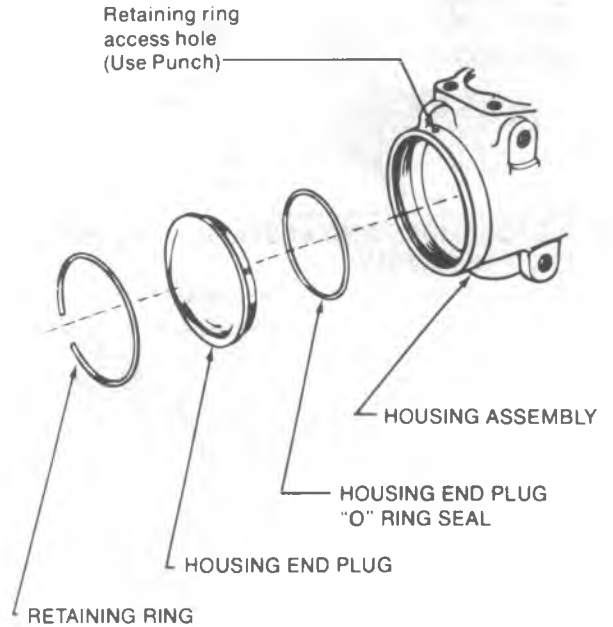

### 4. REMOVE AND INSTALL RACK PISTON

#### REMOVE

1. Remove parts as shown.

#### INSTALL

1. Install parts as shown.

When installing rack, care should be taken not to cut teflon seal, rack piston seal compressor J-7576 or J-8947 may be used to compress seal.

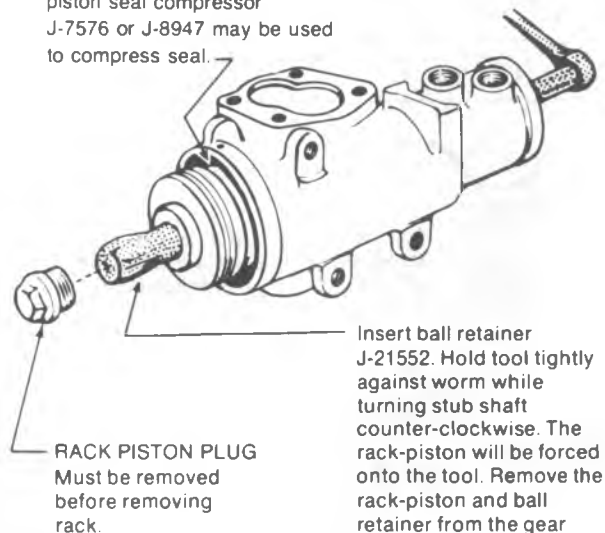

Fig. 3B3-46--Overhaul 800/808 Gear, Chart C

**5. REMOVE AND INSTALL ADJUSTER PLUG ASSEMBLY**

**REMOVE**

1. Loosen lock nut. Use punch against edge of slots.
2. Remove adjuster plug using spanner wrench J-7624.

**INSTALL**

1. Install parts as shown.

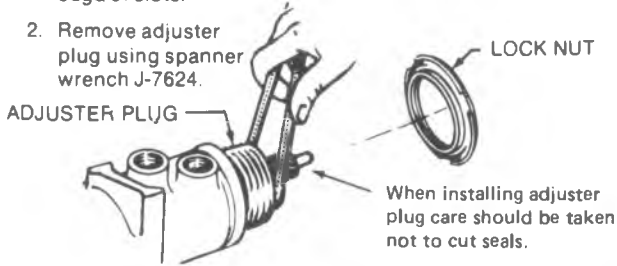

**6. DISASSEMBLE AND ASSEMBLE ADJUSTER PLUG ASSEMBLY**

**DISASSEMBLE**

1. Disassemble parts as shown.

**ASSEMBLE**

1. Assemble parts as shown.

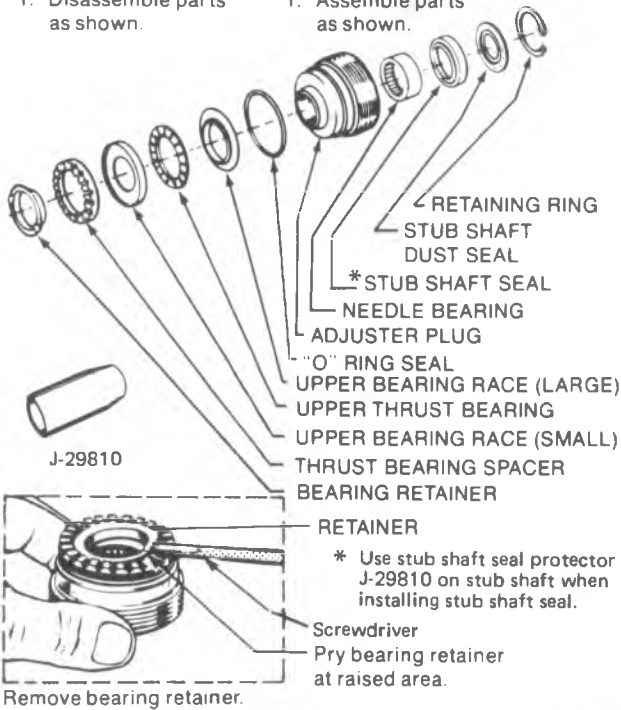

Remove bearing retainer.

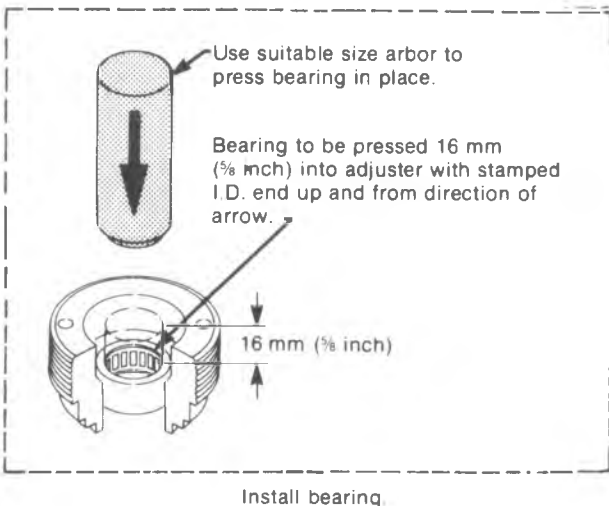

Install bearing.

**7. REMOVE AND INSTALL BEARING, WORM, AND VALVE ASSEMBLY**

**REMOVE**

1. Grasp stub shaft and remove valve and worm assembly as a unit.

**INSTALL**

1. Install parts as shown.

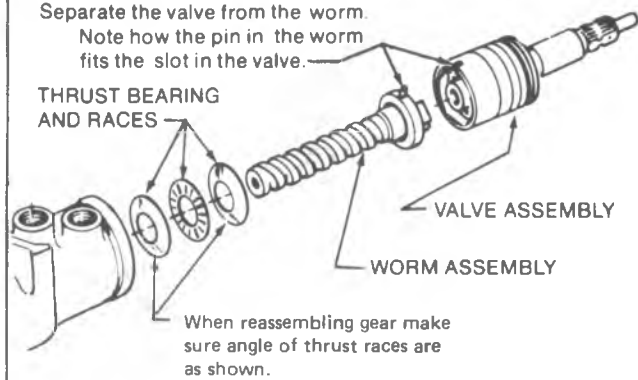

**8. DISASSEMBLE AND ASSEMBLE VALVE**

**DISASSEMBLE**

1. Disassemble parts as shown.

**ASSEMBLE**

1. Assemble parts as shown.

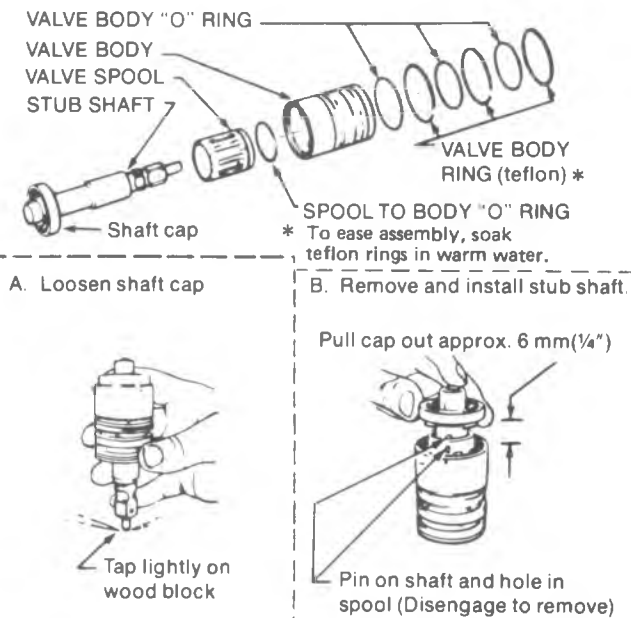

A. Loosen shaft cap



B. Remove and install stub shaft

Pull cap out approx. 6 mm (1/4")

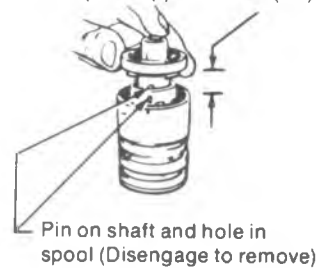

C. Remove and install spool

Rotate while removing or installing



D. Engage stub shaft



Fig. 3B3-47--Overhaul 800/808 Gear, Chart D

**9. DISASSEMBLE AND ASSEMBLE RACK PISTON**

**DISASSEMBLE**

1. Disassemble parts as shown.
2. Clean and inspect all parts for excessive wear.

**ASSEMBLE**

1. Assemble parts as shown.

**The black balls are smaller than the silver balls. The black and silver balls must be installed alternately into the rack-piston and return guide to maintain rack piston to worm gear preload.**

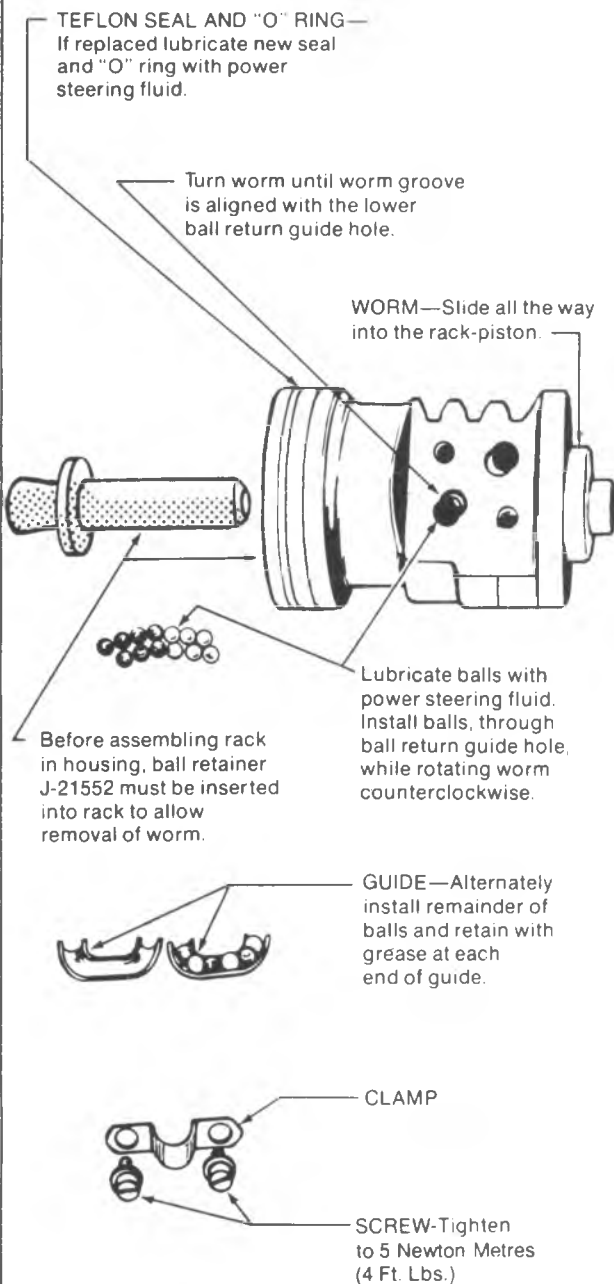

**10. REMOVE AND INSTALL PITMAN SHAFT SEALS AND BEARING**

**REMOVE**

1. Clean end of housing thoroughly to prevent dirt from entering and be extremely careful not to score the housing bore.
2. Remove retaining ring with snap ring pliers J-4245.
3. Using screw driver, pry seals and washers from bore.

**INSTALL**

1. Coat seal lip and washer face with anhydrous calcium grease.
2. Install parts as shown.

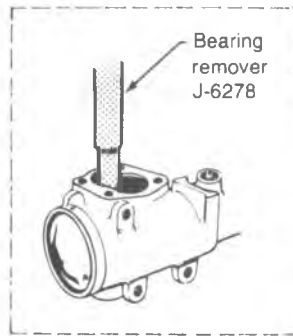
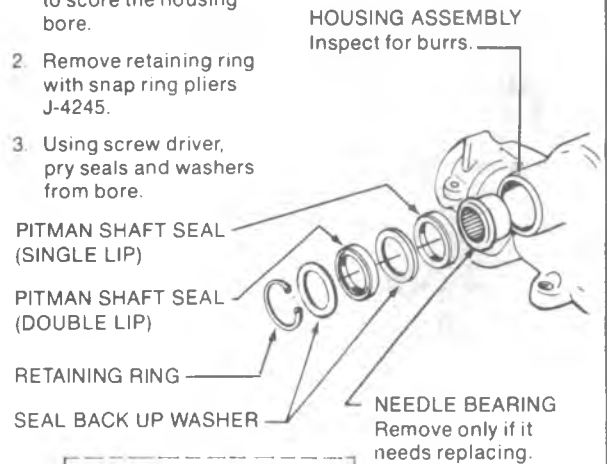

Removing bearing

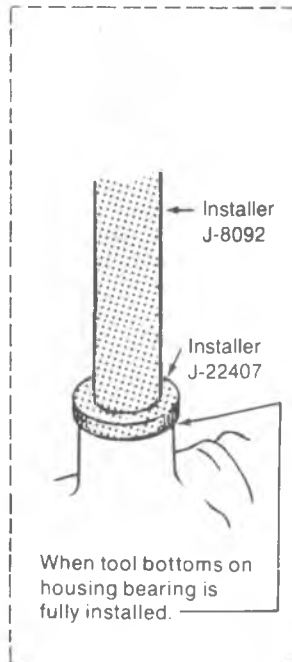

Install Pitman shaft bearing.

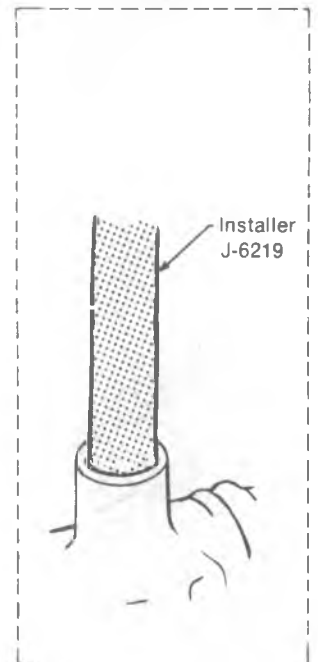

Install Pitman shaft seals.

Fig. 3B3-48--Overhaul 800/808 Gear, Chart E

**11. REMOVE AND INSTALL CHECK VALVE**

**REMOVE**

1. Remove parts as shown.

**INSTALL**

1. Install parts as shown.

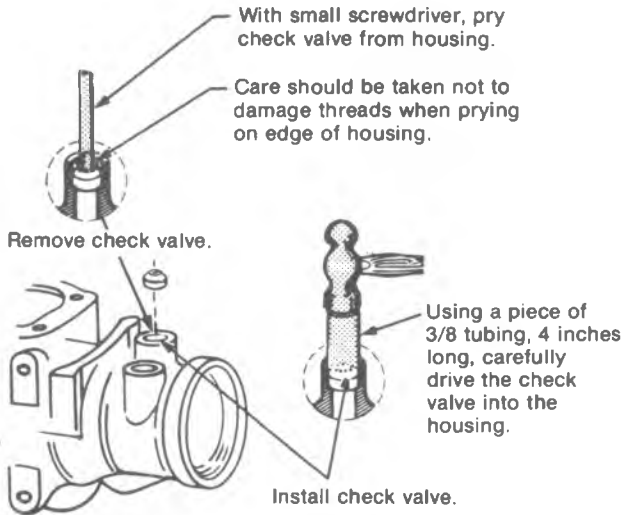

**13. PITMAN SHAFT "OVER-CENTER" SECTOR ADJUSTMENT**

A.

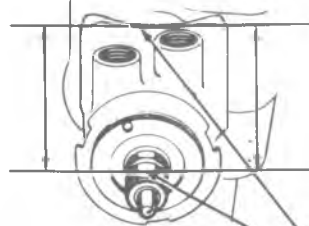

When gear is on center flat on stub shaft is normally on same side as, and parallel with, side cover.

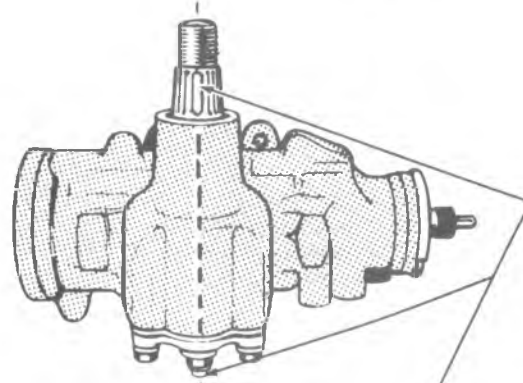

The block tooth on the Pitman shaft is in line with the over-center preload adjuster

**12. ADJUST THRUST BEARING PRELOAD**

A. Using spanner wrench J-7624, tighten adjuster plug until thrust bearing is firmly bottomed, 27 Newton Metres (20 Ft. Lbs.)

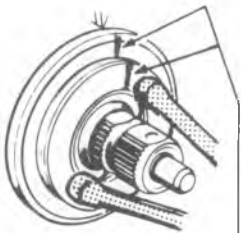

Mark housing and face of adjuster plug.

B.

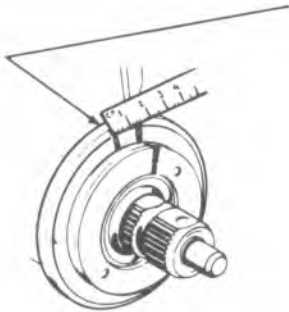

Measure back counterclockwise 13 mm (1/2") and place a second mark on housing.

C.

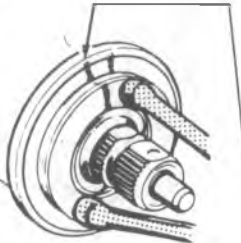

Turn adjuster counterclockwise until mark on face of adjuster lines up with second mark on housing.

D.

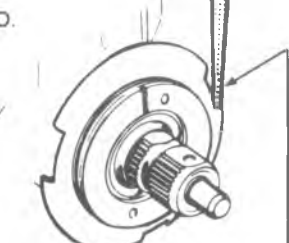

Using punch in notch tighten lock nut securely. Hold adjuster plug to maintain alignment of the marks.

B. Back off preload adjuster until it stops, then turn it in one full turn.



With gear at center of travel, check torque to turn stub shaft (reading #1).

C. Turn adjuster in until torque to turn stub shaft is 0.6 to 1.2 Newton Metres (6 to 10 in. Lbs.) more than reading #1.



Torque adjuster lock nut to 27 Newton Metres (20 Ft. Lbs.)

Prevent adjuster screw from turning while torquing lock nut.

Fig. 3B3-49--Overhaul 800/808 Gear, Chart F

**GENERAL SPECIFICATIONS**

**LUBRICATION**

Lubricant . . . . . Power Steering Fluid No. 1050017 or equivalent

**ADJUSTMENTS**

Valve Assembly and Seal Drag . . . . . 0.1 to 0.4 N•m (1 to 4 in. lbs.)  
 Thrust Bearing Pre-load . . . . . 0.3 to 0.4 N•m (3 to 4 in. lbs.) in excess of valve assembly and seal drag.  
 Overcenter Adjustment . . . . . 0.6 to 1.2 N•m (6 to 10 in. lbs.) (new gear) 0.4 to 0.5 N•m (or 4 to 5 in. lbs.) (used gear)  
 in excess of combined thrust bearing pre-load.

Adjustment of the steering gear in the car is not recommended because of the difficulty encountered in adjusting the worm thrust bearing preload and the confusing effects of the hydraulic fluid in the gear. Since a gear adjustment is made only as a correction and not as a periodic adjustment, it is better to take the extra time and make the adjustment correctly the first time.

Since a handling stability complaint can be caused by improperly adjusted worm thrust bearings as well as an improper gear over-center adjustment, it is necessary that the steering gear assembly be removed from the car and both thrust bearing and over-center preload be checked and corrected as necessary. An in-car check of the steering gear will not show a thrust bearing adjustment error.

**TORQUE SPECIFICATIONS**

| POWER STEERING PUMP            | N•m | FT. LBS. |
|--------------------------------|-----|----------|
| Reservoir Bolt . . . . .       | 48  | 35       |
| Flow Control Fitting . . . . . | 48  | 35       |
| Pressure Hose . . . . .        | 27  | 20       |

**GENERAL SPECIFICATIONS**

**POWER STEERING**

**LUBRICATION**

Lubricant . . . . . Power Steering Fluid No. 1050017 or equivalent  
 Capacity (Exc. Diesel) - Complete System . . . . . 1-1/4 Liters 1-1/4 Qts.  
 Capacity (Diesel) - Complete System . . . . . 1-3/4 Liters 1-3/4 Qts.  
 Capacity - Pump Only . . . . . 1/2 Liter 1/2 Qt.

**STEERING GEAR**

**RECOMMENDED TORQUE SPECIFICATIONS**

|  | NEWTON METERS | FOOT-POUNDS |
|--|---------------|-------------|
| Gear to Frame Bolts . . . . .                  | 110           | 80          |
| High Pressure Line Fitting (At Gear) . . . . . | 27            | 20          |
| Oil Return Line Fitting (At Gear) . . . . .    | 27            | 20          |
| Adjusting Screw Locknut . . . . .              | 27            | 20          |
| Side Cover Bolts . . . . .                     | 60            | 45          |
| Adjuster Plug Locknut . . . . .                | 110           | 80          |
| Coupling Flange Nuts . . . . .                 | 27            | 20          |
| Return Guide Clamp Screws . . . . .            | 5             | 4           |
| Rack-Piston Plug . . . . .                     | 100           | 75          |
| Pitman Shaft Nut . . . . .                     | 240           | 185         |
| Coupling Flange Bolt . . . . .                 | 40            | 30          |

Fig. 3B3-50--Overhaul 800/808 Gear, Chart G

POWER STEERING PUMP

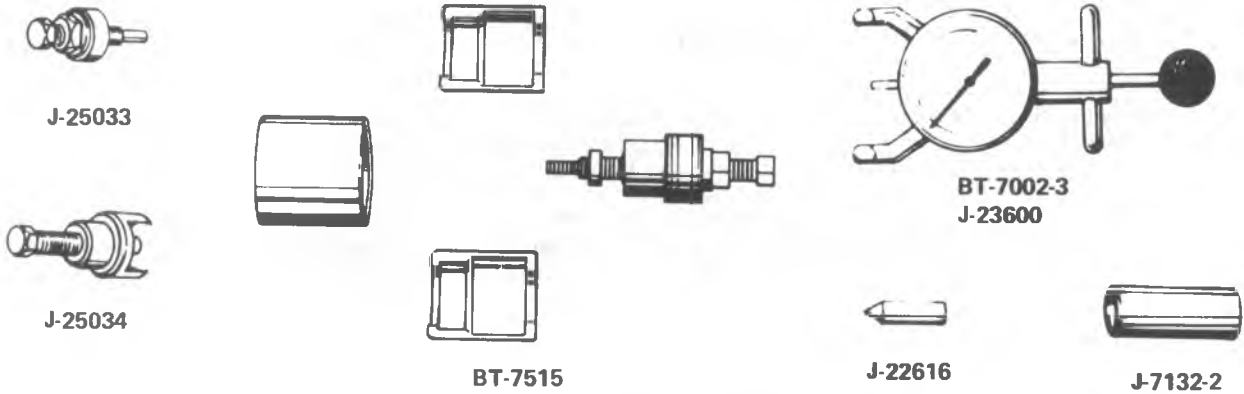

POWER STEERING GEAR

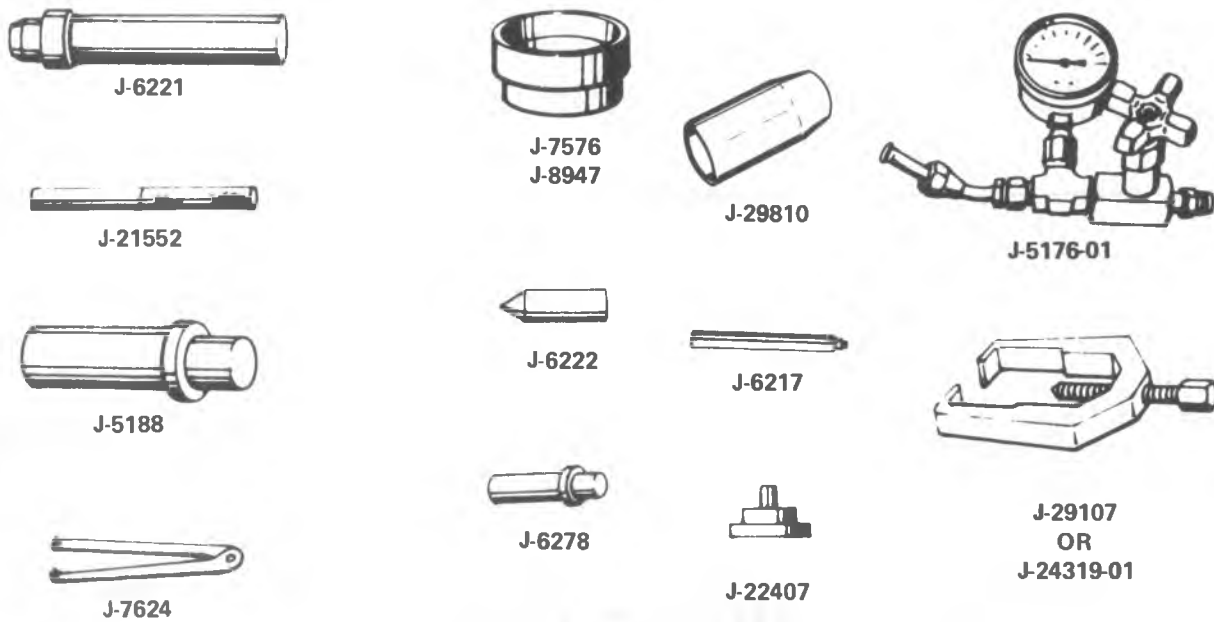

- |           |  |            |                                      |
|-----------|--|------------|--------------------------------------|
| J-5176-01 | Pressure Testing Manifold  | J-7576     | Rack-Piston Teflon Ring Compressor   |
| J-5188    | End Cover Seal and Needle Bearing Installer                              | J-7624     | Spanner Wrench                       |
| J-6217    | Hose Connector Installer   | J-8947     | Rack-Piston Teflon Ring Compressor   |
| J-6221    | Bearing Installer  | J-21552    | Ball Retainer                        |
| J-6222    | End Cover Seal Protector (Used for Installing Adjuster Plug)             | J-24319-01 | Puller                               |
| J-6278    | Pitman Shaft Bearing Remover and Installer                               | J-22407    | Pitman Bearing Installer             |
| J-6278-2  | Adapter (Used with J-6278 for Installing Pitman Shaft Seals and Bearing) | J-22616    | Seal Protector                       |
| BT-7002-3 | Belt Tension Gage  | J-23600    | Belt Tension Gage                    |
| J-7132-2  | Seal Installer   | J-25033    | Power Steering Pump Pulley Installer |
| BT-7515   | Pulley Remover and Installer   | J-25034    | Power Steering Pump Pulley Remover   |
|           |  | J-29107    | Pitman Arm Puller                    |
|           |  | J-29810    | Stub Shaft Seal Protector            |

Fig. 3B3-51--Special Tools



**STEERING GEAR RATIOS**

| Vehicle    | Manual     |                  | Power        |                  |
|------------|------------|------------------|--------------|------------------|
|            | Gear Ratio | Overall Ratio    | Gear Ratio   | Overall Ratio    |
| G10-20     | 24:1       | 29.4:1 to 36.7:1 | 14:1         | 21.4:1 to 26.7:1 |
| G30        | 24:1       | 29.4:1 to 36.4:1 | 14:1         | 21.4:1 to 26.5:1 |
| P20-30     | —          | —                | 17.5:1       | 21.2:1 to 25.7:1 |
| Motor Home | —          | —                | 14:1         | 16.0:1 to 21.9:1 |
| C10        | 24:1       | 29.1:1 to 37.0:1 | 16:1 to 13:1 | 16.9:1 to 20.2:1 |
| C20-30     | 24:1       | 29.4:1 to 36.3:1 | 16:1 to 13:1 | 17.2:1 to 20.6:1 |
| K10-20     | —          | —                | 16:1 to 13:1 | 13.2:1 to 17.2:1 |

**MANUAL STEERING GEAR**

| Components                  | All C-G           |
|-----------------------------|-------------------|
| Thrust Bearing Preload      | 5 to 8 lbs. in.   |
| Adjuster Plug Lock Nut      | 85 lbs. ft.       |
| Over Center Preload         | 4 to 10 lbs. in.* |
| Over Center Lock Nut        | 25 lbs. ft.       |
| Total Steering Gear Preload | 18 lbs. in. Max.  |

\* In excess of thrust bearing preload.

**POWER STEERING PUMP PRESSURES**

| Vehicle        | Pressure        |                 |
|----------------|-----------------|-----------------|
| C10-30         | 1200 - 1300 psi |                 |
| G10-20-30      | w/o Hydroboost  | 900 - 1000 psi  |
| G30            | with Hydroboost | 1350 - 1450 psi |
| P10-30         | 1200 - 1300 psi |                 |
| Motor Home & K | 1350 - 1450 psi |                 |

Fig. 3B3--Specs



## SECTION 3B4

# STEERING COLUMNS

The following notice applies to one or more steps in the assembly procedure of components in this portion of the manual as indicated at appropriate locations by the terminology "See Notice on page 1 of this Section".

**NOTICE:** This fastener is an important attaching part in that it could affect the performance of vital components and systems, and/or could result in major repair expense. It must be replaced with one of the same part number or with an equivalent part if replacement becomes necessary. Do not use a replacement part of lesser quality or substitute design. Torque values must be used as specified during reassembly to assure proper retention of this part.

### CONTENTS

|                                   |        |
|-----------------------------------|--------|
| General Description.....          | 3B4-1  |
| Maintenance and Adjustments ..... | 3B4-3  |
| On-Vehicle Service .....          | 3B4-4  |
| C-Series, K-Series.....           | 3B4-4  |
| G-Series, P-Series .....          | 3B4-20 |
| Specifications .....              | 3B4-35 |
| Special Tools.....                | 3B4-36 |

## GENERAL DESCRIPTION

### FUNCTION LOCKING COLUMNS

The function locking energy absorbing steering column includes three important features in addition to the steering function:

1. The column is energy absorbing, designed to compress in a front-end collision to minimize the possibility of injury to the driver of the vehicle.
2. The ignition switch and lock are mounted conveniently on the column.
3. With the column mounted lock, the ignition, steering and gearshifting operation can be locked to inhibit theft of the vehicle.

The function locking energy absorbing column may be easily disassembled and reassembled. It is important that only the specified screws, bolts and nuts be used as designated and that they are tightened to their specified torque. This precaution will insure the energy absorbing action of the assembly. Over-length bolts should not be used, as they may prevent a portion of the assembly from compressing under impact. Equally as important is correct torque of bolts and nuts. Care should be taken to assure that the bolts or nuts securing the column mounting bracket to the instrument panel are torqued to the proper specification in order that the bracket will break away under impact.

When the function locking energy absorbing column assembly is installed in a vehicle, it is no more susceptible to damage through usage than an ordinary column; however,

when the column is removed, special care must be taken in handling this assembly. Only the specified wheel puller should be used. When the column is removed from the vehicle, such actions as a sharp blow on the end of the steering shaft or shift lever, leaning on the column assembly, or dropping of the assembly could shear or loosen the plastic fasteners that maintain column rigidity. It is, therefore, important that the removal and installation and the disassembly and reassembly procedures be carefully followed when servicing the assembly.

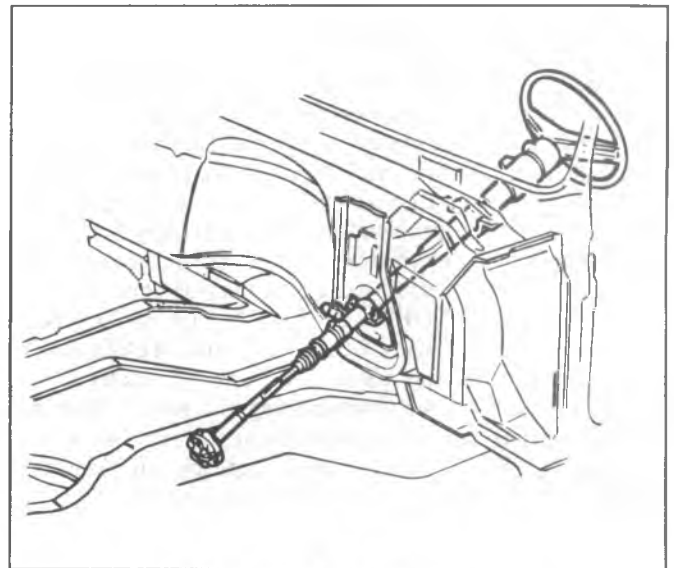

Fig. 3B4-1--Steering Column

## GENERAL INFORMATION

This section contains diagnostic information to help locate the cause of the problem in the column. Reference should be made to the correct method of column disassembly, repair, adjustment and reassembly. Damaged, broken or deformed parts must be replaced with the correct replacement.

To perform diagnostic procedures on the steering column upper end components, it is not necessary to remove the column from the vehicle.

The steering wheel, horn components, directional signal switch, ignition switch and lock cylinder may be removed with the column remaining in the vehicle as described in the Service Manual under "Component Part Replacement".

**CAUTION: The outer mast jacket shift tube, steering shaft and instrument panel mounting bracket are designed as energy absorbing units. Because of the design of these components, it is absolutely necessary to handle the column with care when performing any service operation. Avoid hammering, jarring, dropping or leaning on any portion of the column. When reassembling the column components, use only the specified screws, nuts and bolts and tighten to specified torque. Care should be exercised not to use over-length screws or bolts as they may prevent a portion of the column from compressing under impact. Personal injury could result from lack of care when servicing the steering column.**

## STEERING COLUMN ELECTRICAL ANALYZER J-23980

### For C-Series and K-Series

Tool J-23980 will help the technician analyze the steering column wiring harness for electrical problems. The tool in actuality eliminates the steering column, related wiring and components; and replaces them with the tool itself. In this way disassembly of the column is not performed until the problem has been determined to be in the column. By moving the tester switch, (with the key in the "on" position), the various functions may be checked. The switch positions are "OFF", "HORN", "LEFT TURN", "RIGHT TURN", "KEY BUZZER", and "HAZARD". (Trucks do not incorporate a Key Buzzer Switch) if the systems function properly while using the tester, then the malfunction has been narrowed to the column wiring or components. When this has been determined then the column may be serviced to correct the malfunction.

To use the tool just unfasten the harmonica connector on the column and plug the harness from J-23980 into the vehicle chassis harness. The "A", "B", and "C" terminals on the tester will overhang the chassis connector. This does not affect the test results. These terminals are for vehicles with cornering lights. Connect the single black jumper to a good ground. The tester is now ready for use.

## COLLISION DIAGNOSIS

To determine if the energy absorbing steering column components are functioning as designed, or if repairs are required, a close inspection should be made. An inspection is called for in all cases where damage is evident or whenever the vehicle is being repaired due to a front end collision. Whenever a force has been exerted on the steering wheel or steering column, or its components, inspection should also be made. If damage is evident, the affected parts must be replaced. See Section 3 for Diagnosis.

The inspection procedure for the various steering column components on C and K trucks is as follows:

### Column Support Bracket

Damage in this area will be indicated by separation of the mounting capsules from the bracket. The bracket will have moved forward toward the engine compartment and will usually result in collapsing of the jacket section of the steering column.

### COLUMN JACKET

Inspect jacket section of column for looseness, and/or bends.

### SHIFTER SHAFT

Separation of the shifter shaft sections will be internal and cannot be visually identified. Hold lower end of the "shifter shaft" and move "shift lever" on column through its ranges and up and down. If there is little or no movement of the "shifter shaft", the plastic joints are sheared.

### Steering Shaft

If the steering shaft plastic pins have been sheared, the shaft will rattle when struck lightly from the side and some lash may be felt when rotating the steering wheel while holding the rag joint. It should be noted that if the steering shaft pins are sheared due to minor collision with no appreciable damage to other components, that the vehicle can be safely steered; however, steering shaft replacement is recommended.

Because of the differences in the steering column types, be sure to refer to the set of instructions below which apply to the column being serviced.

### METHOD TO DETERMINE COLUMN COLLAPSE

Measure distance between top of neutral-start switch window opening and the bottom of the upper jacket. The correct value is shown below:

- a. C-Truck 5 11/16" to 5 1/2".
- b. K-Truck 5 11/16" to 5 1/2".

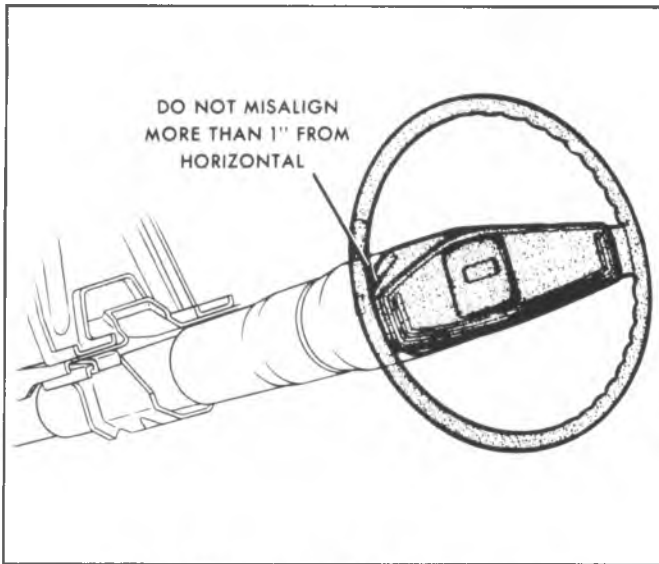

Fig. 3B4-2--Steering Wheel Alignment

## MAINTENANCE AND ADJUSTMENTS

### STEERING WHEEL ALIGNMENT

On all series vehicles, check steering gear for high point centering as shown in Sections 3B2 and 3B3 before checking steering wheel alignment.

1. Set wheels in straight ahead position by driving vehicle a short distance.
2. Note steering wheel position. If off more than 1 inch from center (Fig. 3B4-2), remove steering wheel as outlined under "Steering Wheel - Removal", center high point on gear, reposition and reinstall the wheel.

### STEERING COLUMN LOWER BEARING ADJUSTMENT

G and P Series Only

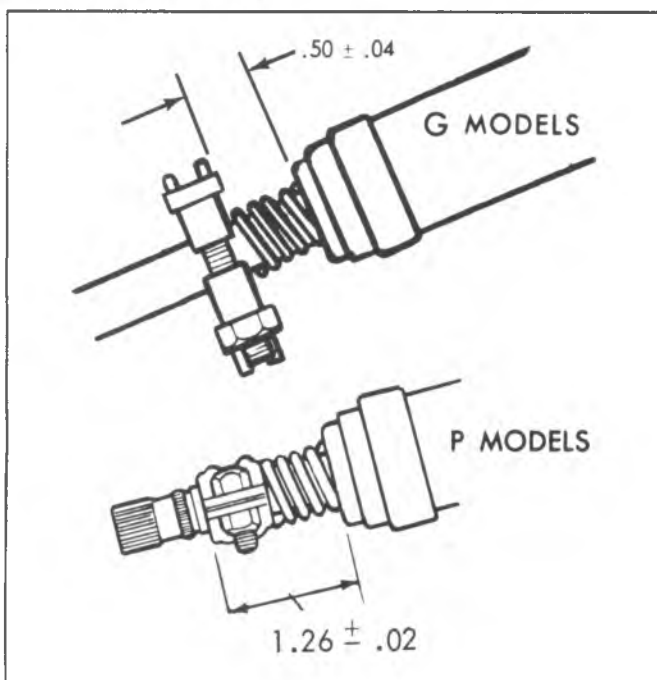

Fig. 3B4-3--Steering Column Lower Bearing Adjustment

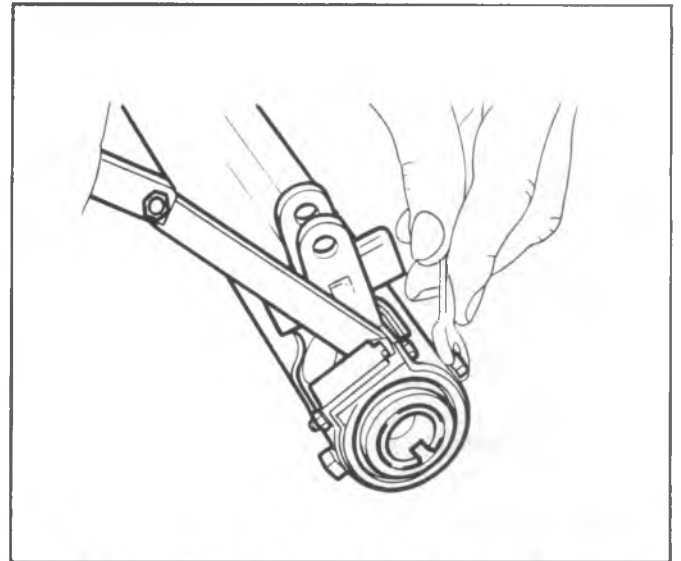

Fig. 3B4-4--Shift Tube Adjustment-3 Speed Manual Transmission

1. Loosen clamp on steering shaft.
2. Applying 50 lb. force to the steering wheel end of the steering shaft, adjust clamp to obtain clearances indicated in Figure 3B4-3.
3. Tighten clamp bolt to specified torque.

### SHIFTER TUBE ADJUSTMENT G and P Series Only

#### 3-Speed Transmission

1. Loosen adjusting ring attaching screws and clamp bolt.
2. Rotate adjusting ring to give .005" end play between adjusting ring and first and reverse shifter lever (Fig. 3B4-4).
3. Tighten attaching screws and clamp bolt.

#### Automatic Transmission

1. Place the shift tube lever in "Neutral" or "Drive".
2. Loosen adjusting ring clamp screws and rotate the shift tube adjusting ring to obtain .33" to .36" clearance between the shift tube lever and adjusting ring (Fig. 3B4-5).
3. Tighten the adjusting ring clamp screws to 70 in. lbs.

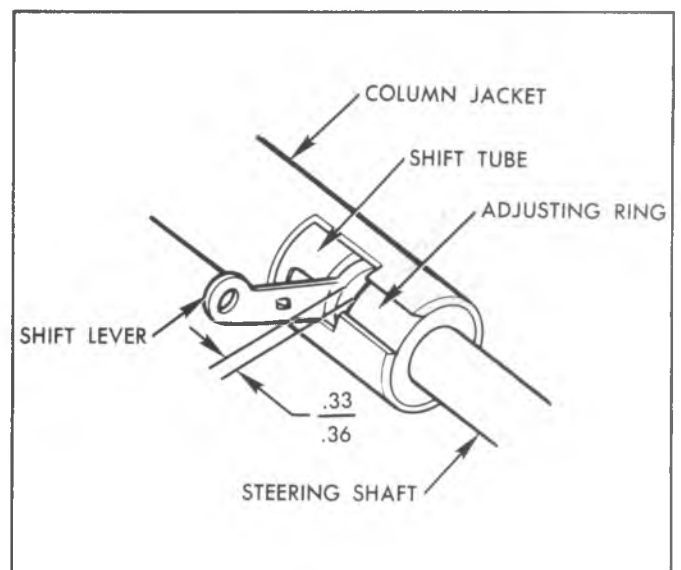

Fig. 3B4-5--Shift Tube Adjustment-Automatic Transmission

## ON-VEHICLE SERVICE

### INDEX

|  |        |
|--|--------|
| C-Series and K-Series .....            | 3B4-4  |
| Steering Wheel .....                   | 3B4-4  |
| Flexible Coupling.....                 | 3B4-4  |
| Intermediate Shaft.....                | 3B4-5  |
| Directional Signal Switch.....         | 3B4-6  |
| Lock Cylinder .....                    | 3B4-7  |
| Ignition Switch.....                   | 3B4-7  |
| Steering Column.....                   | 3B4-8  |
| Removal .....                          | 3B4-9  |
| Disassembly, Standard Column .....     | 3B4-10 |
| Disassembly, Tilt Column .....         | 3B4-10 |
| Installation, Mandatory Sequence ..... | 3B4-20 |

|  |        |
|--|--------|
| G-Series and P-Series.....             | 3B4-20 |
| Steering Wheel .....                   | 3B4-20 |
| Flexible Coupling.....                 | 3B4-21 |
| Intermediate Shaft.....                | 3B4-21 |
| Column Upper Bearing .....             | 3B4-23 |
| Column Lower Bearing .....             | 3B4-23 |
| Tilt Column Bearing Housing.....       | 3B4-24 |
| Directional Signal Switch.....         | 3B4-25 |
| Steering Column .....                  | 3B4-27 |
| Removal .....                          | 3B4-27 |
| Disassembly, Standard Column .....     | 3B4-27 |
| Disassembly, Tilt Column .....         | 3B4-29 |
| Installation, Mandatory Sequence ..... | 3B4-33 |

### STEERING WHEEL

#### Removal

1. Disconnect battery ground cable.
2. Remove horn button cap.
3. Remove snap ring and steering wheel nut.
4. Using tool J-1859-03, thread puller anchor screws into holes provided on steering wheel. See Fig. 3B4-6. Turn center bolt of tool clockwise to remove wheel.

**NOTICE:** Do not hammer on puller, or damage could occur to the components. The tool centering adapters need not be used.

#### Installation

**NOTICE:** See NOTICE on page 1 of this section regarding the fasteners referred to in step 1.

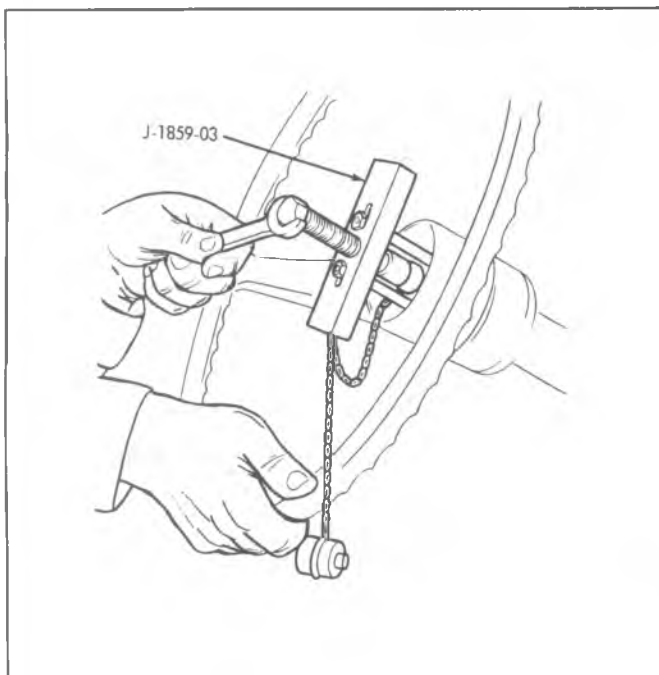

Fig. 3B4-6--Steering Wheel Removal

1. With turn signal in neutral position, align marks and set wheel onto steering shaft. Torque steering shaft nut to specifications and install snap ring.

**NOTICE:** Do not over torque shaft nut or steering wheel rub may result.

2. Place steering wheel horn button on wheel and snap into proper position.
3. Connect battery ground cable.

### STEERING COUPLING (FLEXIBLE TYPE)

#### Removal

1. Remove the coupling to steering shaft flange bolt nuts.
2. Remove the coupling clamp bolt. This is a special bolt and will require a 12 pt. socket or box wrench.
3. Remove the steering gear to frame bolts and lower the steering gear far enough to remove the flexible coupling. It is not necessary to disconnect the pitman arm from the pitman shaft.
4. Tap lightly on the flexible coupling with a soft mallet to remove the coupling from the steering gear wormshaft.

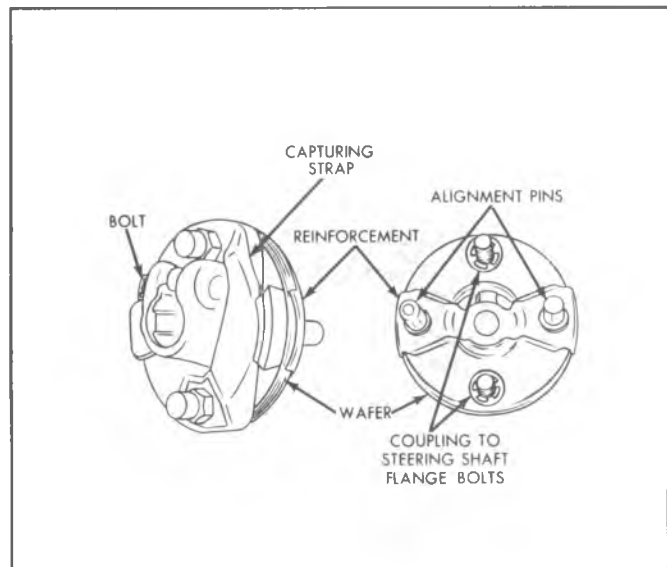

Fig. 3B4-7--Flexible Type Steering Coupling

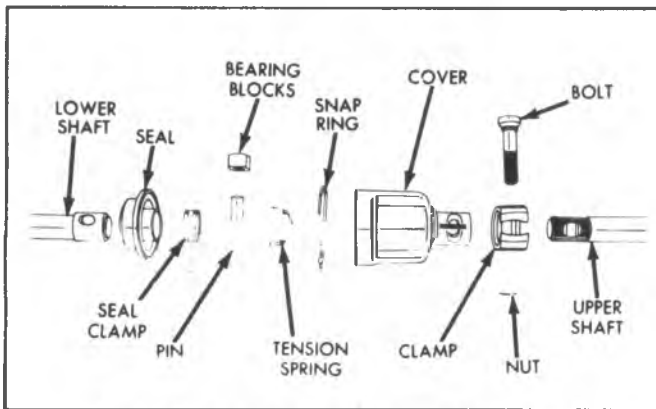

Fig. 3B4-8--Steering Shaft Intermediate Coupling

#### Installation

**NOTICE:** See NOTICE on page 1 of this section regarding the fasteners referred to in steps 2, 4 and 5.

1. Install the flexible coupling onto the steering gear wormshaft, aligning the flat on the shaft with the flat in the coupling. Push the coupling onto the wormshaft until the coupling reinforcement bottoms against the end of the worm.
2. Install the special bolt into the split clamp and torque to specifications.
 

**NOTICE:** The bolt must pass through the shaft undercut, or damage could occur to the components.
3. Place the steering gear into position, guiding the flexible coupling bolts into the proper holes in the steering shaft flange.
4. Install and tighten the steering gear to frame bolts.
5. Install the coupling to flange bolt nuts and washers and torque to specifications. Be sure to maintain a coupling to flange dimension of .250" to .375". The coupling alignment pins should be centered in the flange slots.

### INTERMEDIATE STEERING SHAFTS WITH POT JOINT COUPLINGS

#### Removal

1. Remove the lower shaft flange to flexible coupling bolts.
2. Remove upper shaft to intermediate coupling bolt.
3. If necessary, remove the steering gear to frame bolts and lower the steering gear far enough to remove the intermediate shaft assembly. It is not necessary to remove the pitman arm from the pitman shaft.

#### Disassembly

1. Mark cover to shaft relationship. Pry off snap ring and slide cover from shaft.
2. Remove bearing blocks and tension spring from pivot pin.
3. Clean grease off pin and end of shaft. Scribe location mark on pin on same side as chamfer in shaft.

4. Supporting shaft assembly securely, with chamfer up, press pin out of shaft with arbor press.

**NOTICE:** Do not drive pin out with hammer. This could cause sticky or binding bearings when reassembled.

5. Remove seal clamp and slide seal off end of shaft.

#### Assembly

1. Be sure all parts are free of dirt. Slide seal onto steering shaft. With lip of seal against step in shaft clamp seal.
2. Press pin back into shaft from chamfered side. Locate pin in shaft using scribe mark as reference.

**NOTICE:** Pin must be centered within .012 in. or binding in the coupling could result.

3. Check centering of pin (Fig. 3B4-9).
  - a. Place just enough 3/8" flat washers on pin to prevent bearing block from bottoming when installed.
  - b. Measure distance from end of pin to top of bearing with micrometer.
  - c. Remove bearing and washers and place same bearing and washers on other end of pin. Measure distance from end of pin to top of bearing. If micrometer readings in Steps b and c differ more than .012, repeat last part of Step 2 and recheck.
4. Apply a liberal amount of wheel bearing grease to inside and outside of bearing blocks and inside of cover.
5. Position tension spring and bearing blocks on pin.
6. Slide cover over bearing blocks aligning reference mark on cover with mark on shaft. Install seal into end of cover and secure with snap ring retainer.

#### Installation

**NOTICE:** See NOTICE on page 1 of this section regarding the fasteners referred to in steps 1, 3 and 4.

1. Install the intermediate shaft assembly onto the

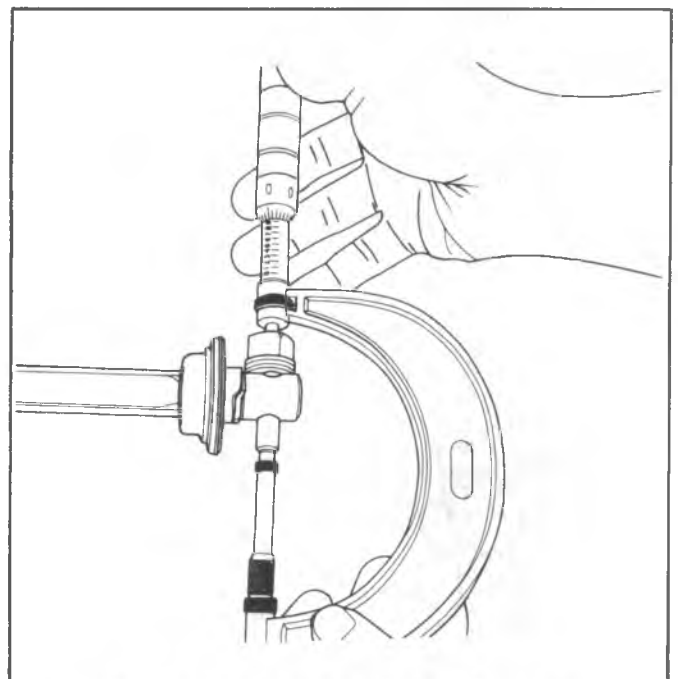

Fig. 3B4-9--Checking Coupling Pin Centering

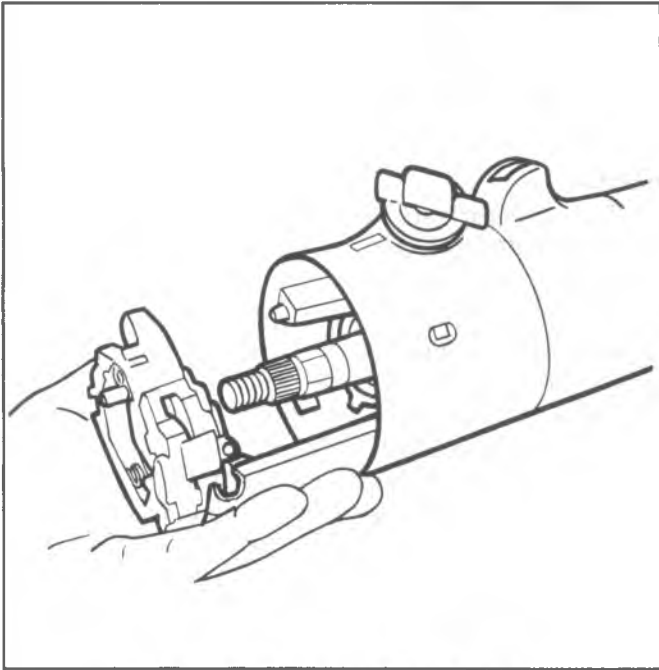

Fig. 3B4-10--Directional Signal Switch

steering shaft, aligning the flat on the shaft with the flat in the coupling. Install the pot joint clamp bolt and torque to specifications.

2. Lift the steering gear into position, guiding the flexible coupling bolts into the shaft flange holes.
3. Install the steering gear to frame bolts and torque to specifications.
4. Install the flexible coupling to steering shaft flange bolt lockwashers and nuts. Check that the coupling alignment pins are centered in the flange slots and then torque the coupling bolts to specifications.

### DIRECTIONAL SIGNAL SWITCH

The directional signal switch can be removed with the steering column in the vehicle and without disturbing any of the column mountings.

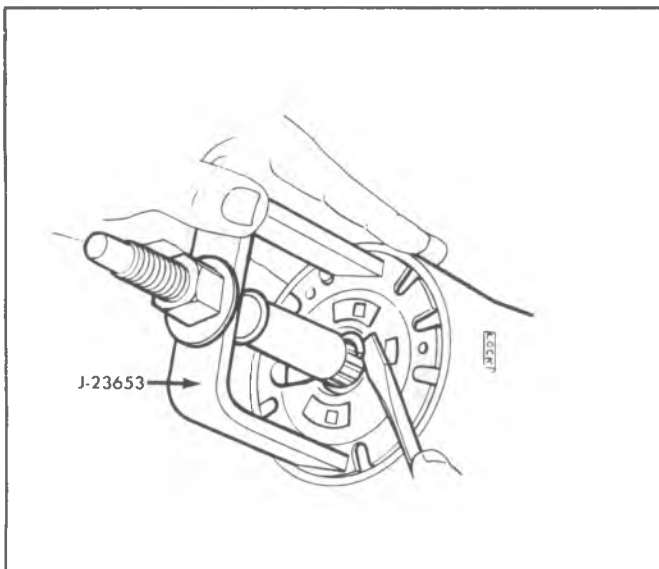

Fig. 3B4-11--Removing Lock Plate Retaining Ring

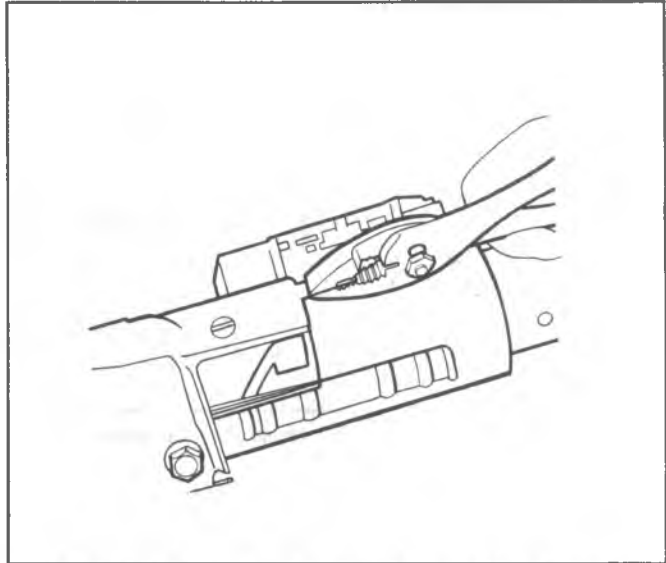

Fig. 3B4-12--Removing Directional Signal Wire Protector

### Removal (Fig. 3B4-10)

1. Remove the steering wheel as outlined under "Steering Wheel - Removal".
  2. Remove the column to instrument panel trim cover.
  3. Position screwdriver blade into cover slot. Pry up and out to free cover from lock plate.
  4. Screw the center post of Lock Plate Compressing Tool J-23653 onto the steering shaft as far as it will go. Compress the lock plate by turning the center post nut clockwise (Fig. 3B4-11). Pry the round wire snap ring out of the shaft groove and discard the ring. Remove Tool J-23653 and lift the lock plate off the end of the shaft.
- NOTICE:** If the column is being disassembled on the bench, with the snap ring removed the shaft could slide out of the lower end of the mast jacket, damaging the shaft assembly.
5. Slide the directional signal cancelling cam, upper bearing preload spring and thrust washer off the end of the shaft.

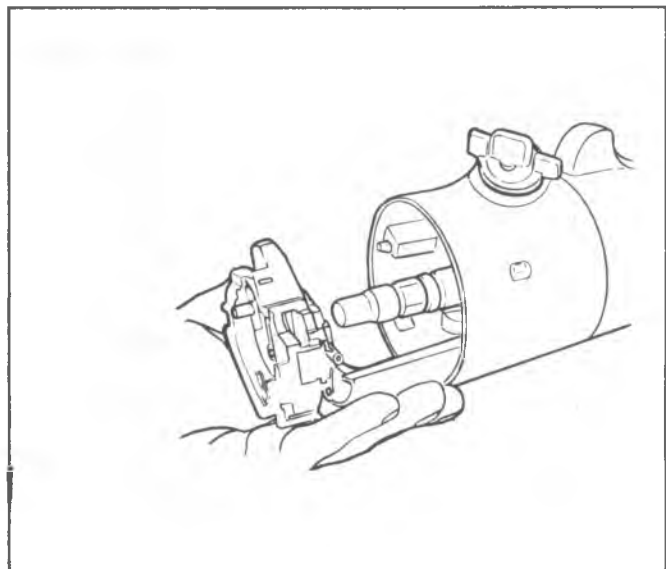

Fig. 3B4-13--Removing Directional Signal Switch Assembly



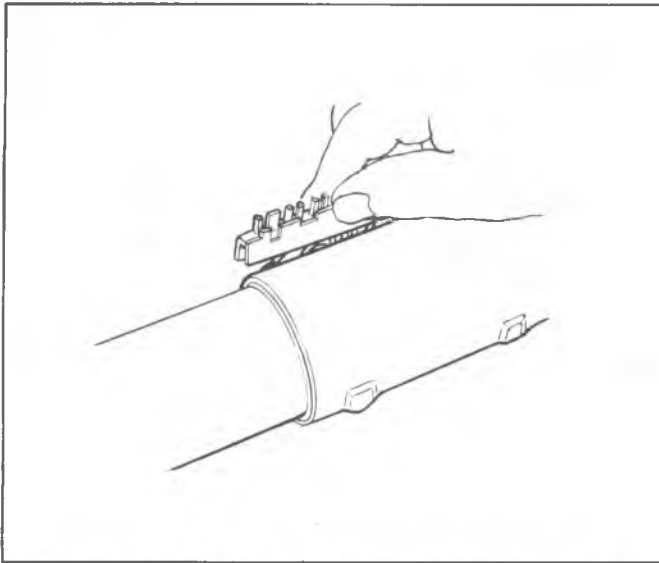

Fig. 3B4-14--Installing Switch Connector Onto Jacket Clips

6. Remove the directional signal lever screw and remove the lever.
7. Push the hazard warning knob in and unscrew the knob.
8. Remove the three switch mounting screws.
9. **All Columns** - Pull the switch connector out of the bracket on the jacket and feed switch connector through column support bracket and pull switch straight up, guiding the wiring harness through the column housing and protector.
10. Remove wire protector by pulling downward out of column with pliers using tab provided (Fig. 3B4-12).  
**Tilt Column** - Position the direction signal and shifter housing in the "low" position. Remove the harness cover by pulling toward the lower end of the column, be careful not to damage the wires.
11. Remove the three switch mounting screws and pull the switch straight up, guiding the wiring harness and cover through the column housing (Fig. 3B4-13).

#### Installation

**CAUTION:** It is extremely important that only the specified screws, bolts and nuts be used at assembly, or personal injury could result. Use of overlength screws could prevent a portion of the assembly from compressing under impact.

1. **All except Tilt** - Be sure that the wiring harness is in the protector. Feed the connector and cover down through the housing and under the mounting bracket (column in vehicle).  
**Tilt** - Feed the connector down through the housing and under the mounting bracket. Then install the cover on the harness.
2. Install the three mounting screws and clip the connector to the bracket on the jacket (Fig. 3B4-14).
3. Install the column to instrument panel trim plate.
4. Install the hazard warning knob and directional signal lever.

5. Make certain that the switch is in "Neutral" and the hazard warning knob is out. Slide the thrust washer, upper bearing preload spring and cancelling cam onto the upper end of the shaft.
6. Place the lock plate onto the end of the shaft. Screw the center post of Lock Plate Compressing Tool J-23653 onto the steering shaft as far as it will go. Place a NEW snap ring over the center post. Place the "C" bar over the center post and then compress the lock plate by turning the nut clockwise. Slide the new snap ring down the tapered center post and into the shaft groove (Fig. 3B4-15). Remove Tool J-23653.  
Always use a new snap ring when reassembling.
7. Place cover on the lock plate and snap into position.
8. Install the steering wheel as outlined under "Steering Wheel-Installation".

#### LOCK CYLINDER

The lock cylinder is located on the upper right hand side of the column. The lock cylinder should be removed in the "RUN" position only.

#### Replacement

1. Remove the steering wheel as outlined under "Steering Wheel - Removal".
2. Remove the directional signal switch as outlined under "Directional Signal Switch - Removal".  
It is not necessary to completely remove the directional signal switch from the column. Pull the switch rearward far enough to slip it over the end of the shaft - do not pull the harness out of the column.
3. Refer to Fig. 3B4-16 for details on replacement of lock cylinder.

#### IGNITION SWITCH

The ignition switch is mounted on top of the column jacket near the front of the dash. For anti-theft reasons, the switch is located inside the channel section of the brake pedal support and is completely inaccessible without first lowering the steering column (see steering column removal).

The switch is actuated by a rod and rack assembly. A portion of the rack is toothed and engages a gear on the end

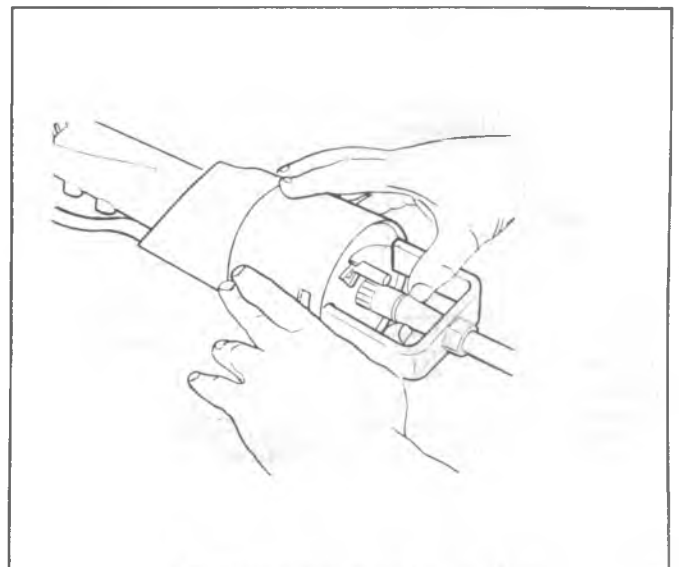

Fig. 3B4-15--Installing Snap Ring

### LOCK CYLINDER INSTALLATION

#### DISASSEMBLE

1. Place lock in "run".
2. Remove lock plate, turn signal switch and buzzer switch (see service manual.)
3. Remove screw & lock cylinder. **CAUTION:** If screw is dropped on removal, it could fall into the column, requiring complete disassembly to retrieve the screw.

#### ASSEMBLE

1. Rotate as shown, align cylinder key with keyway in housing.
2. Push lock all the way in.
3. Install screw. Tighten to 4.5 N·m for regular columns—2.5 N·m for adjustable columns.

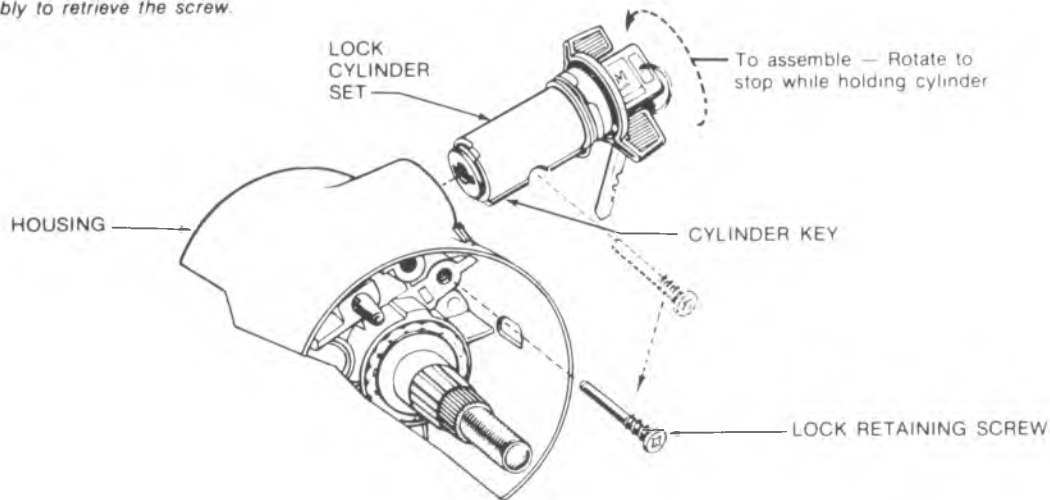

Fig. 3B4-16--Lock Cylinder Removal

of the lock cylinder, thus enabling the rod and rack to be moved axially (with respect to the column) to actuate the switch when the lock cylinder is rotated.

#### Removal

1. Lower the steering column as outlined under "Steering Column Removal" later in this section. It is not necessary to remove the steering wheel.

If the steering column is not removed from the vehicle, be sure that it is properly supported, before proceeding.

2. The switch should be positioned in "Lock" position before removing. If the lock cylinder has already been removed, the actuating rod to the switch should be pulled up until there is a definite stop, then moved down one detent, which is the "Lock" position.
3. Remove the two switch screws and remove the switch assembly.

#### Installation

1. Before replacing the switch, be sure that the lock is in the "Lock" position (Fig. 3B4-17); if it is not, a screwdriver (placed in the locking rod slot) can be used to move the switch to "Lock".
2. Install the activating rod into the switch and assemble the switch on the column; tighten the mounting screws.

**CAUTION:** Use only the specified screws since over-length screws could prevent a portion of the assembly from compressing under impact, which could result in personal injury.

3. Reinstall the steering column assembly following the "Mandatory Installation Sequence" outlined later in this section.

#### STEERING COLUMN

To perform service procedures on the steering column upper end components, it is not necessary to remove the column from the vehicle.

The steering wheel, horn components, directional signal switch, and ignition lock cylinder may be removed with the column remaining in the vehicle as described earlier in this section.

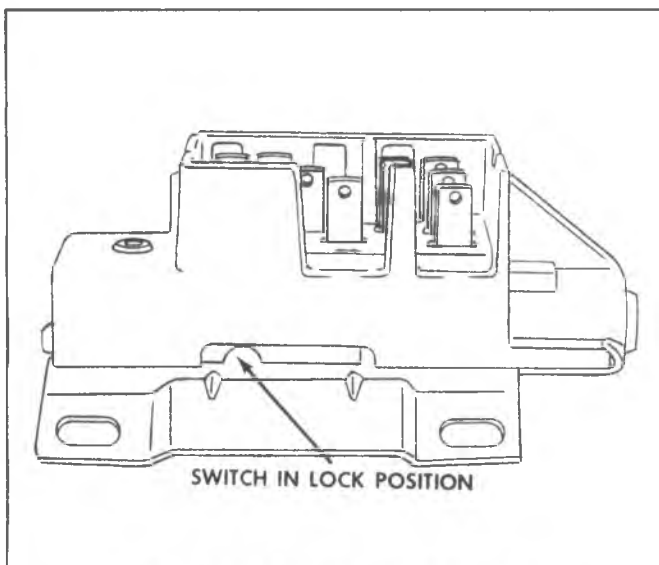

Fig. 3B4-17--Ignition Switch Assembly

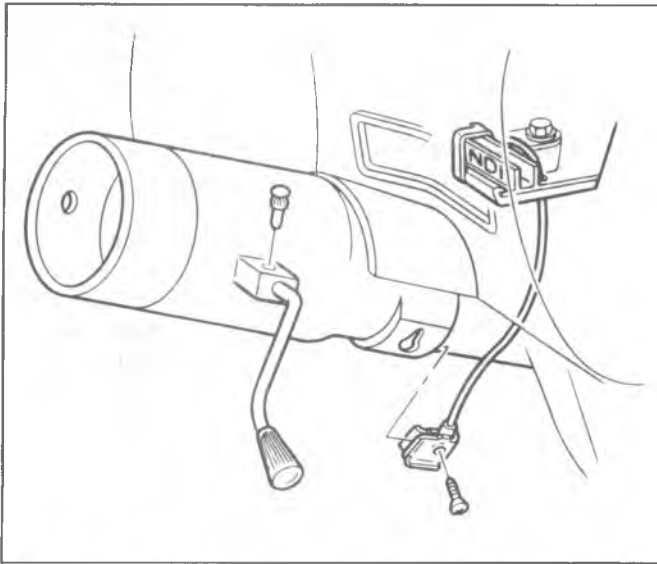

Fig. 3B4-18--Automatic Transmission Indicator Connection-CK-Typical

**CAUTION:** The outer mast jacket shift tube, steering shaft and instrument panel mounting bracket are designed as energy absorbing units. Because of the design of these components, it is absolutely necessary to handle the column with care when performing any service operation. Avoid hammering, jarring, dropping or leaning on any portion of the column. When reassembling the column components, use only the specified screws, nuts and bolts and tighten to specified torque. Care should be exercised in using over-length screws or bolts as they may prevent a portion of the column from compressing under impact.

#### Inspection

To determine if the energy absorbing steering column components are functioning as designed, or if repairs are required, a close inspection should be made. Inspection is called for in all cases where damage is evident or whenever the vehicle is being repaired due to a front end collision. Whenever a force has been exerted on the steering wheel or steering column, or its components, inspection should also be made. If damage is evident, the affected parts must be replaced.

The inspection procedure for the various steering column components on all C and K Series Trucks is as follows:

#### Column Support Bracket

Damage in this area will be indicated by separation of the mounting capsules from the bracket. The bracket will have moved forward toward the engine compartment and will usually result in collapsing of the jacket section of the steering column.

#### Column Jacket

Inspect jacket section of column for looseness, and/or bends.

#### Shifter Shaft

Separation of the shifter shaft sections will be internal and cannot be visually identified. Hold lower end of the "shifter shaft" and move "shift lever" on column through its ranges and up and down. If there is little or no movement of the "shifter shaft", the plastic joints are sheared.

#### Steering Shaft

If the steering shaft plastic pins have been sheared, the shaft will rattle when struck lightly from the side and some lash may be felt when rotating the steering wheel while holding the rag joint. It should be noted that if the steering shaft pins are sheared due to minor collision the vehicle can be safely steered; however, steering shaft replacement is recommended.

Because of the differences in the steering column types, be sure to refer to the set of instructions below which apply to the column being serviced.

#### Removal

Front of dash mounting plates must be loosened whenever the steering column is to be lowered from the instrument panel.

1. Disconnect the battery ground cable.
2. Remove the steering wheel as outlined under "Steering Wheel Removal".
3. Remove the nuts and washers securing the flanged end of the steering shaft to the flexible coupling.
4. Disconnect the transmission control linkage from the column shift tube levers.
5. Disconnect the steering column harness at the connector. Disconnect the neutral-start switch and back-up lamp switch connectors if so equipped.
6. Remove the floor pan trim cover screws and remove the cover.
7. Remove the transmission indicator cable, if so equipped (Fig. 3B4-18).
8. Remove the screws securing the two halves of the floor pan cover; then remove the screws securing the halves and seal to the floor pan and remove the covers (Fig. 3B4-19).
9. Move the front seat as far back as possible to provide maximum clearance.
10. Remove the two column bracket-to-instrument panel

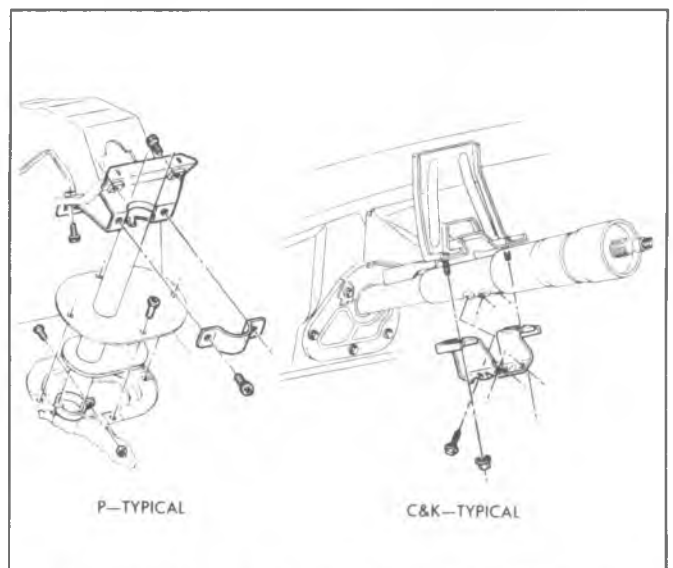

Fig. 3B4-19--Steering Column to Dash Panel-C, K Typical

nuts and carefully remove from vehicle. Additional help should be obtained to guide the lower shift levers through the firewall opening.

### C and K Series, Standard Column - (Fig. 3B4-21)

#### Disassembly

1. Remove the four dash panel bracket-to-column screws and lay the bracket in a safe place to prevent damage to the mounting capsules.
2. Place the column in a vise using both weld nuts of either Set A or B as shown in Figure 3B4-22. The vise jaws must clamp onto the sides of the weld nuts indicated by arrows shown on Set B.

**NOTICE:** Do not place the column in a vise by clamping onto one weld nut of both sets A and B or by clamping onto the sides not indicated by arrows, since damage to the column could result.

3. Remove the Directional Signal Switch, Lock Cylinder, and Ignition Switch as outlined previously in this section.
4. **Column Shift Models** - Drive out the upper shift lever pivot pin and remove the shift lever.
5. Remove the upper bearing thrust washer. Remove the four screws attaching the turn signal and ignition lock housing to the jacket and remove the housing assembly (Fig. 3B4-23).
6. Remove the thrust cap from the lower side of the housing.
7. Lift the ignition switch actuating rod and rack assembly, the rack preload spring and the shaft lock bolt and spring assembly out of the housing (Fig. 3B4-24).
8. Remove the shift lever detent plate (shift gate).
9. Remove the ignition switch actuator sector through the lock cylinder hole by pushing firmly on the block tooth of the sector with a blunt punch or screwdriver (Fig. 3B4-25).
10. Remove the gearshift lever housing and shroud from the jacket assembly (transmission control lock tube housing and shroud on floor shift models).
11. Remove the shift lever spring from the gearshift lever housing (lock tube spring on floor shift models).
12. Pull the steering shaft from lower end of the jacket assembly.
13. Remove the two screws holding the back-up switch or neutral-safety switch to the column and remove the switch.
14. Remove the lower bearing retainer clip (Fig. 3B4-26).
15. **Automatic and Floorshift Columns** - Remove the lower bearing retainer, bearing adapter assembly, shift tube thrust spring and washer. The lower bearing may be removed from the adapter by light pressure on the bearing outer race. Slide out the shift tube assembly.

**Manual Transmission - Column Shift** - Remove the lower bearing adapter, bearing and the first reverse shift lever. The lower bearing may be removed from the

adapter by light pressure on the bearing outer race. Remove the three screws from bearing at the lower end and slide out the shift tube assembly. Remove the gearshift housing lower bearing from the upper end of the mast jacket.

#### Assembly of Standard Columns

Apply a thin coat of lithium soap grease to all friction surfaces.

1. Install the sector into the turn signal and lock cylinder housing. Install the sector in the lock cylinder hole over the sector shaft with the tang end to the outside of the hole. Press the sector over the shaft with a blunt tool.
2. Install the shift lever detent plate onto the housing.
3. Insert the rack preload spring into the housing from the bottom side. The long section should be toward the handwheel and hook onto the edge of the housing (Fig. 3B4-27).
4. Assemble the locking bolt onto the crossover arm on the rack and insert the rack and lock bolt assembly into the housing from the bottom with the teeth up (toward hand-wheel) and toward the centerline of the column (Fig. 3B4-24). Align the 1st tooth on the sector with the 1st tooth on the rack; if aligned properly, the block teeth will line up when the rack assembly is pushed all the way in.
5. Install the thrust cup on the bottom hub of the housing.
6. Install the gearshift housing lower bearing. Insert the bearing from the very end of the jacket. Aligning the indentations in the bearing with the projections on the jacket (Fig. 3B4-28). If the bearing is not installed correctly, it will not rest on all of the stops provided.
7. Install the shift lever spring into the gearshift lever (or lock tube) housing. Install the housing and shroud assemblies onto the upper end of the mast jacket. Rotate the housing to be sure it is seated in the bearing.
8. With the shift lever housing in place, install the turn signal and lock cylinder housing onto the jacket. The gearshift housing should be in "Park" position and the rack pulled downward. Be sure the turn signal housing is seated on the jacket and drive the four screws.
9. Press the lower bearing into the adapter assembly.
10. Insert the shift tube assembly into the lower end of the jacket and rotate until the upper shift tube key slides into the housing keyway.
11. **Automatic and Floor shift Columns** - Assemble the spring and lower bearing and adapter assembly into the bottom of the jacket. Holding the adapter in place, install the lower bearing reinforcement and retainer clip. Be sure the clip snaps into the jacket and reinforcement slots.
12. **Manual Transmission - Column Shift** - Loosely attach the three screws in the jacket and shift tube bearing. Assemble the 1st-Reverse lever and lower bearing and adapter assembly into the bottom of the jacket. Holding the adapter in place, install the bearing reinforcement and retaining clip. Be sure the retaining clip snaps into the jacket and reinforcement slots. Refer to Fig. 3B4 — 29 for adjustment procedure.

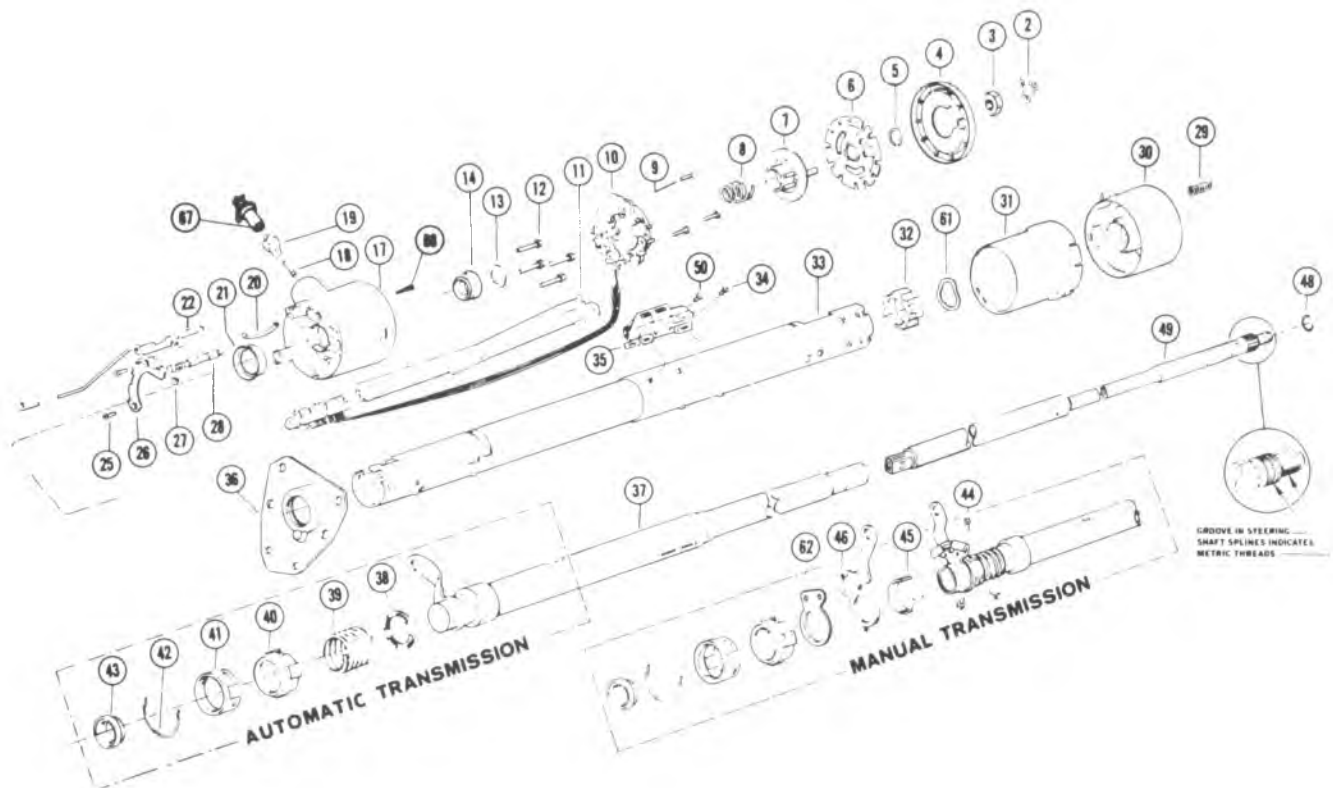

- |  |  |
|--|--|
| <ul style="list-style-type: none"> <li>1. STEERING COLUMN</li> <li>2. RETAINER</li> <li>3. NUT, Hexagon Jam</li> <li>4. COVER, Shaft Lock</li> <li>5. RING, Retaining</li> <li>6. LOCK, Steering Shaft</li> <li>7. CAM ASM, Turn Signal Cancelling</li> <li>8. SPRING, Upper Bearing</li> <li>9. SCREW, Pan Head Cross Recess</li> <li>10. SWITCH ASM, Turn Signal</li> <li>11. PROTECTOR, Wiring</li> <li>12. SCREW, Hex Washer Head Tapping</li> <li>13. WASHER, Thrust</li> <li>14. BEARING ASM</li> <li>17. HOUSING, Steering Column</li> <li>18. SHAFT, Sector</li> <li>19. SECTOR, Switch Actuator</li> <li>20. SPRING, Rack Preload</li> <li>21. CUP, Thrust</li> <li>22. RACK ASM, Rod &amp;</li> <li>23. SCREW, Dimmer Switch Mounting</li> <li>24. SWITCH ASM, Dimmer</li> <li>25. SCREW, Flat Head Cross Recess</li> <li>26. GATE, Shift Lever</li> <li>27. WASHER, Spring Thrust</li> <li>28. BOLT ASM, Spring &amp;</li> <li>29. SPRING, Upper Shift Lever</li> </ul> | <ul style="list-style-type: none"> <li>30. BOWL, Gearshift Lever</li> <li>31. SHROUD, Shift Bowl</li> <li>32. BEARING, Bowl Lower</li> <li>33. JACKET ASM, Steering Column</li> <li>34. SCREW, Washer Head</li> <li>35. SWITCH ASM, Ignition</li> <li>36. SEAL, Dash</li> <li>37. TUBE ASM, Shift</li> <li>38. WASHER, Spring Thrust</li> <li>39. SPRING, Shift Tube Return</li> <li>40. ADAPTER, Lower Bearing</li> <li>41. RETAINER, Bearing Adapter</li> <li>42. CLIP, Lower Bearing Adapter</li> <li>43. BEARING ASM</li> <li>44. SCREW ASM, Lockwasher &amp;</li> <li>45. SPACER, Lower Shift Lever</li> <li>46. LEVER, Lower Shift</li> <li>47. BUSHING ASM, Steering Shaft</li> <li>48. RING, Retaining</li> <li>49. SHAFT ASM, Steering</li> <li>50. SCREW, Flat Head</li> <li>51. ROD, Dimmer Switch Actuator</li> <li>61. WASHER, Wave</li> <li>62. PLATE, Support &amp; Alignment</li> <li>67. LOCK CYLINDER SET, Strg Column</li> <li>68. SCREW, Lock Retaining</li> </ul> |
|--|--|

Fig. 3B4-20--Std. Column; Auto. Trans. or 3-Speed

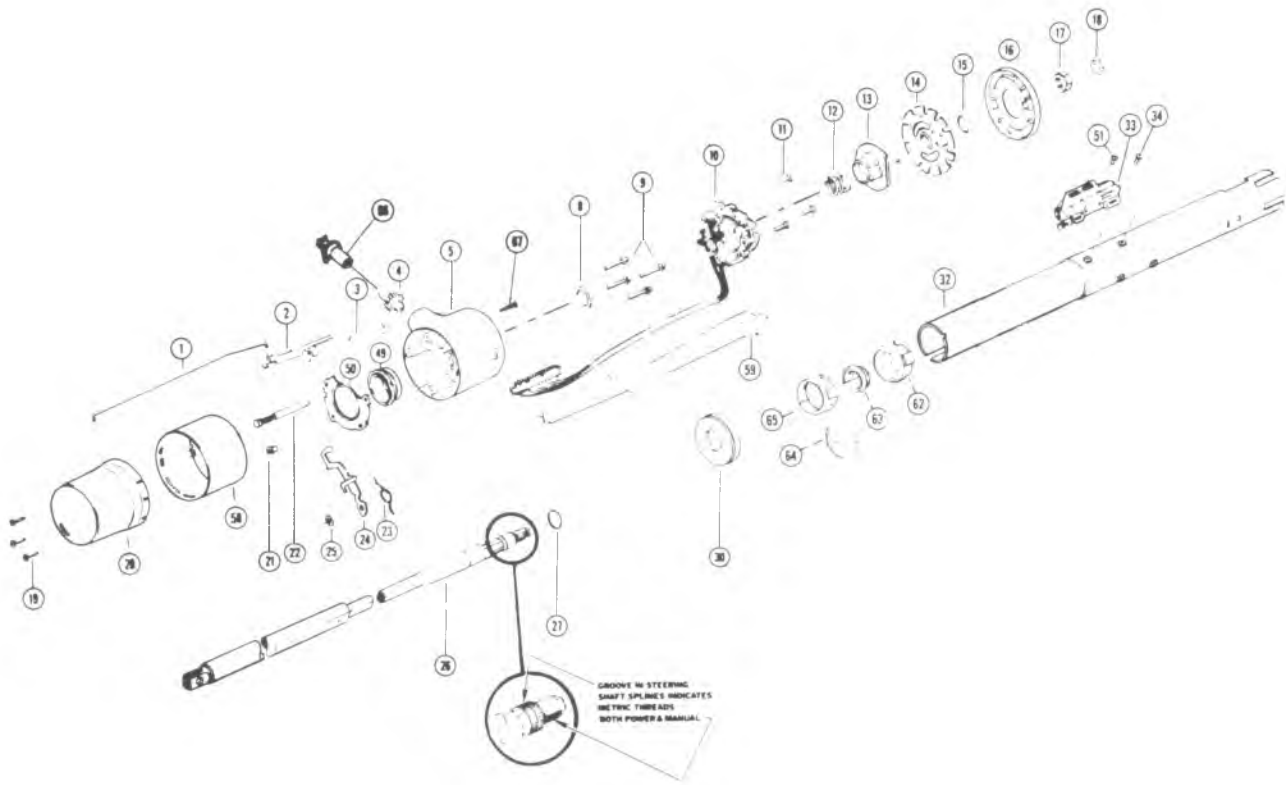

- |                                     |                                    |
|-------------------------------------|------------------------------------|
| 1. ROD, Switch Actuator             | 23. SPRING, Key Release            |
| 2. RACK, Switch Actuator            | 24. LEVER, Key Release             |
| 3. SPRING, Rack Preload             | 25. WASHER, Wave                   |
| 4. SECTOR, Switch Actuator          | 26. SHAFT ASSEMBLY, Steering       |
| 5. HOUSING, Steering Column         | 27. RING, Retaining                |
| 8. WASHER, Thrust                   | 30. SEAL, Jacket & Dash Bracket    |
| 9. SCREW, Hex Washer Head Tapping   | 32. JACKET ASSEMBLY, Sleeve        |
| 10. SWITCH ASSEMBLY, Turn Signal    | 33. SWITCH ASSEMBLY, Ignition      |
| 11. SCREW, Pan Head Cross Recess    | 34. SCREW, Washer Head             |
| 12. SPRING, Upper Bearing           | 49. BEARING ASM                    |
| 13. CAM ASM, Turn Signal Cancelling | 50. RETAINER, Upper Bearing        |
| 14. LOCK, STEERING SHAFT            | 51. SCREW, Flat Head               |
| 15. RING, Retaining                 | 58. BOWL, Floor Shift              |
| 16. COVER, Shaft Lock               | 59. PROTECTOR, Wiring              |
| 17. NUT, Hexagon Jam                | 62. ADAPTER, Lower Bearing         |
| 18. RETAINER                        | 63. BEARING ASM                    |
| 19. SCREW, Pan Head Cross Recess    | 64. CLIP, Lower Bearing Adapter    |
| 20. SHROUD, Steering Column         | 65. RETAINER, Bearing Adapter      |
| 21. WASHER, Spring Thrust           | 66. LOCK CYLINDER SET, Strg Column |
| 22. BOLT ASSEMBLY, Spring           | 67. SCREW, Lock Retaining          |

Fig. 3B4-21--Std. Column, 4-Speed Trans.

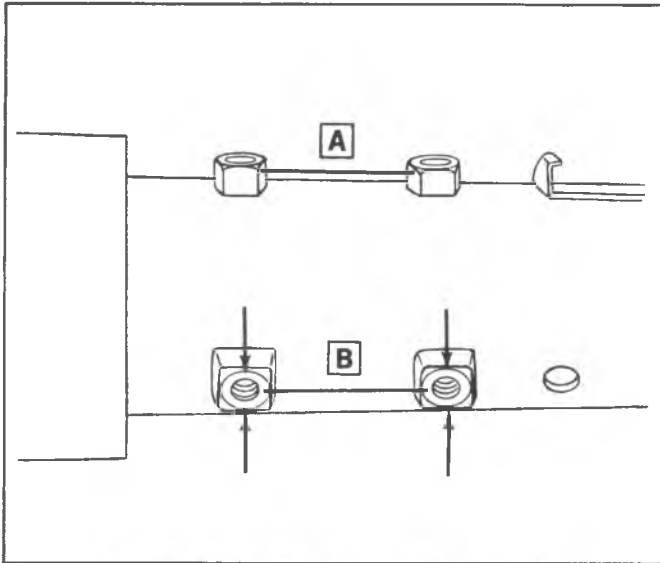

Fig. 3B4-22--Installing Steering Column in Vise

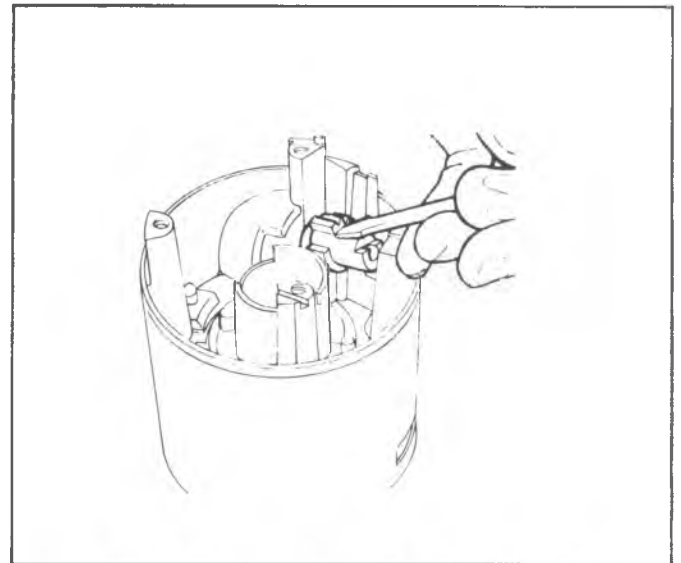

Fig. 3B4-25--Removing Ignition Switch Actuator Sector

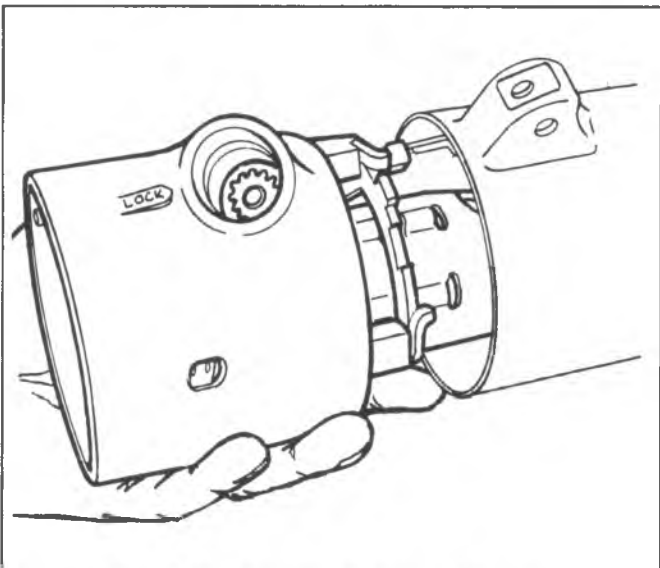

Fig. 3B4-23--Removing Turn Signal Housing

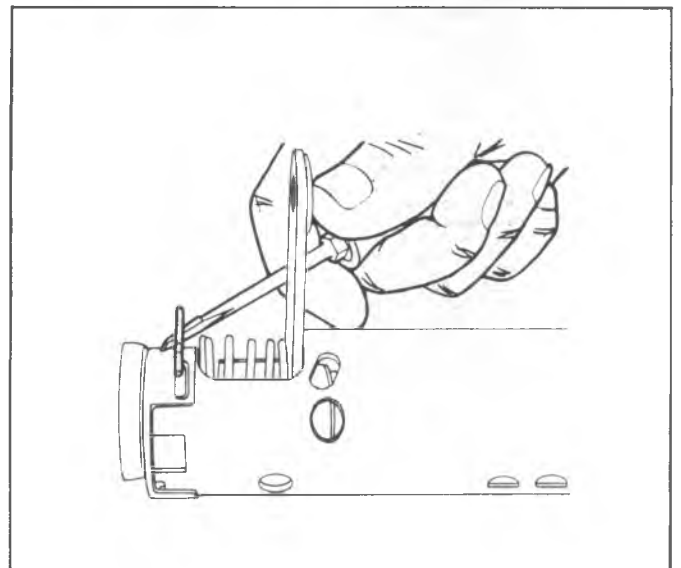

Fig. 3B4-26--Removing Lower Bearing Retainer

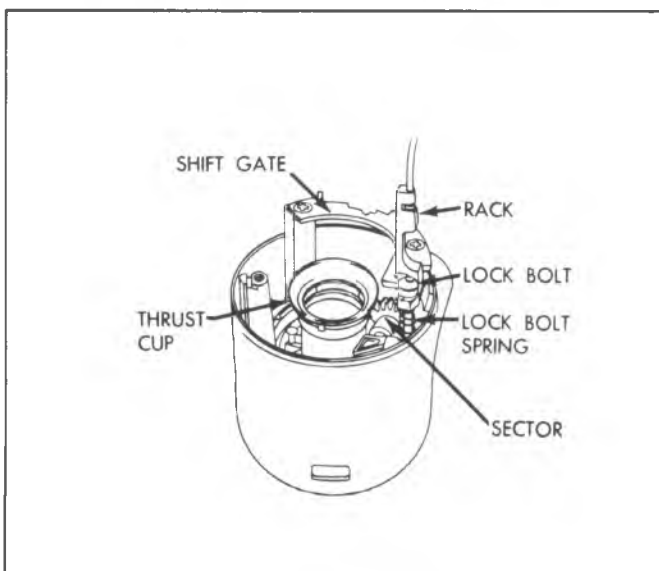

Fig. 3B4-24--Turn Signal Housing Assembly

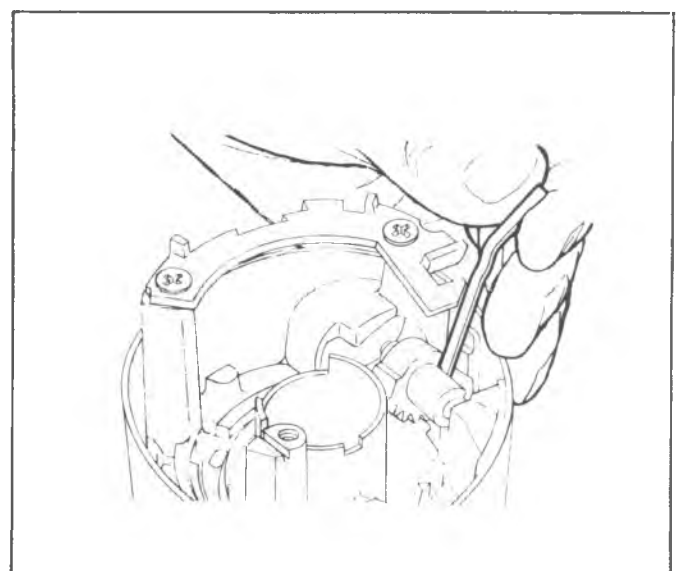

Fig. 3B4-27--Installing Rack Preload Spring

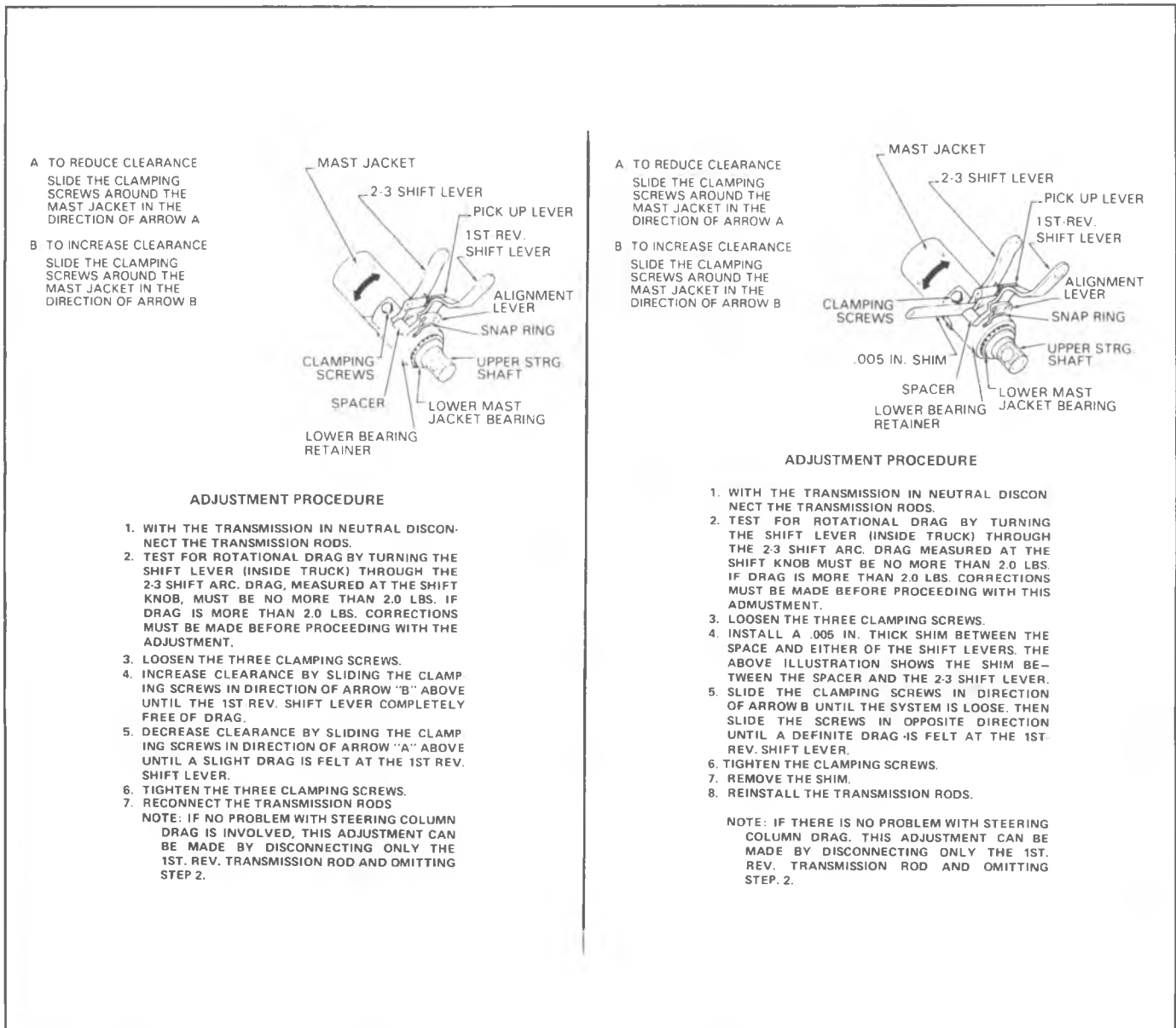

Fig. 3B4-29--Adjusting Lower Bearing-Typical

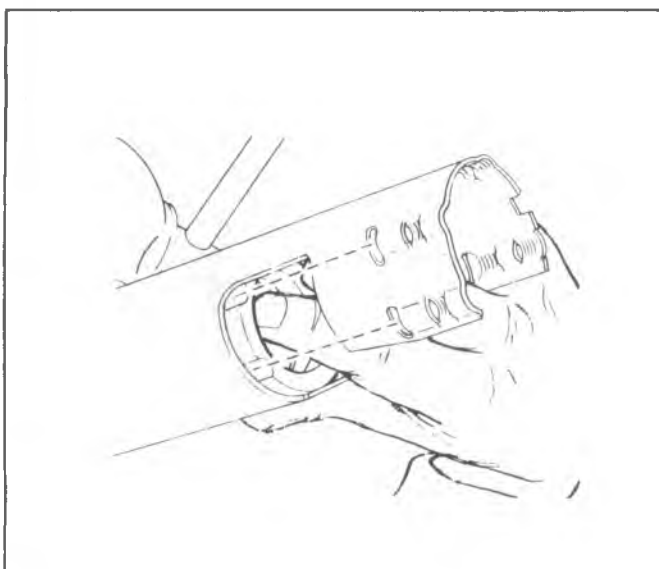

Fig. 3B4-28--Installing Gearshift Housing Lower Bearing

A TO REDUCE CLEARANCE  
SLIDE THE CLAMPING  
SCREWS AROUND THE  
MAST JACKET IN THE  
DIRECTION OF ARROW A

B TO INCREASE CLEARANCE  
SLIDE THE CLAMPING  
SCREWS AROUND THE  
MAST JACKET IN THE  
DIRECTION OF ARROW B

**ADJUSTMENT PROCEDURE**

1. WITH THE TRANSMISSION IN NEUTRAL DISCONNECT THE TRANSMISSION RODS.
  2. TEST FOR ROTATIONAL DRAG BY TURNING THE SHIFT LEVER (INSIDE TRUCK) THROUGH THE 2-3 SHIFT ARC. DRAG, MEASURED AT THE SHIFT KNOB, MUST BE NO MORE THAN 2.0 LBS. IF DRAG IS MORE THAN 2.0 LBS. CORRECTIONS MUST BE MADE BEFORE PROCEEDING WITH THE ADJUSTMENT.
  3. LOOSEN THE THREE CLAMPING SCREWS.
  4. INCREASE CLEARANCE BY SLIDING THE CLAMPING SCREWS IN DIRECTION OF ARROW "B" ABOVE UNTIL THE 1ST REV. SHIFT LEVER COMPLETELY FREE OF DRAG.
  5. DECREASE CLEARANCE BY SLIDING THE CLAMPING SCREWS IN DIRECTION OF ARROW "A" ABOVE UNTIL A SLIGHT DRAG IS FELT AT THE 1ST REV. SHIFT LEVER.
  6. TIGHTEN THE THREE CLAMPING SCREWS.
  7. RECONNECT THE TRANSMISSION RODS
- NOTE: IF NO PROBLEM WITH STEERING COLUMN DRAG IS INVOLVED, THIS ADJUSTMENT CAN BE MADE BY DISCONNECTING ONLY THE 1ST. REV. TRANSMISSION ROD AND OMITTING STEP 2.

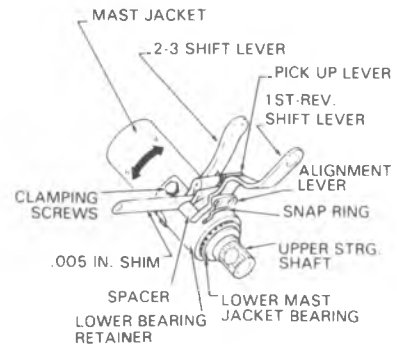

**ADJUSTMENT PROCEDURE**

1. WITH THE TRANSMISSION IN NEUTRAL DISCONNECT THE TRANSMISSION RODS.
  2. TEST FOR ROTATIONAL DRAG BY TURNING THE SHIFT LEVER (INSIDE TRUCK) THROUGH THE 2-3 SHIFT ARC. DRAG MEASURED AT THE SHIFT KNOB MUST BE NO MORE THAN 2.0 LBS. IF DRAG IS MORE THAN 2.0 LBS. CORRECTIONS MUST BE MADE BEFORE PROCEEDING WITH THIS ADJUSTMENT.
  3. LOOSEN THE THREE CLAMPING SCREWS.
  4. INSTALL A .005 IN. THICK SHIM BETWEEN THE SPACE AND EITHER OF THE SHIFT LEVERS. THE ABOVE ILLUSTRATION SHOWS THE SHIM BETWEEN THE SPACER AND THE 2-3 SHIFT LEVER.
  5. SLIDE THE CLAMPING SCREWS IN DIRECTION OF ARROW B UNTIL THE SYSTEM IS LOOSE. THEN SLIDE THE SCREWS IN OPPOSITE DIRECTION UNTIL A DEFINITE DRAG IS FELT AT THE 1ST-REV. SHIFT LEVER.
  6. TIGHTEN THE CLAMPING SCREWS.
  7. REMOVE THE SHIM.
  8. REINSTALL THE TRANSMISSION RODS.
- NOTE: IF THERE IS NO PROBLEM WITH STEERING COLUMN DRAG, THIS ADJUSTMENT CAN BE MADE BY DISCONNECTING ONLY THE 1ST. REV. TRANSMISSION ROD AND OMITTING STEP 2.

13. Install the neutral-safety or back-up switch as outlined in Section 8 of this manual.
14. Slide the steering shaft into the column and install the upper bearing thrust washer.
15. Install the turn signal switch, lock cylinder assembly and ignition switch as previously outlined in this section.
16. Install the shift lever and shift lever pivot pin.
17. Remove the column from the vise.
18. Install the dash bracket to the column; torque the screws to specifications.

**Disassembly-Tilt Columns**

Steps 3-14 may be performed with the steering column in the vehicle.

1. Remove the four screws retaining the dash mounting bracket to the column and set the bracket aside to protect the breakaway capsules.



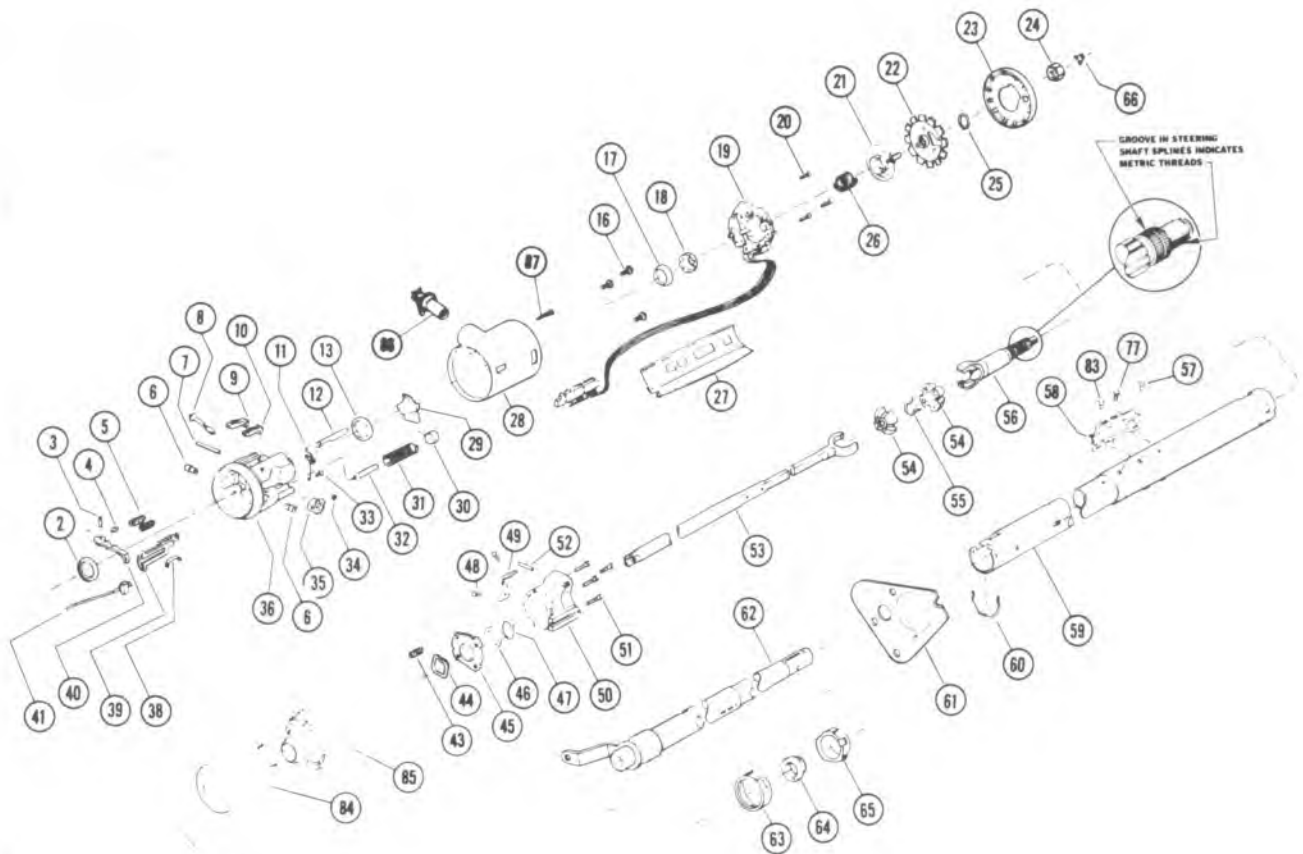

- |                                     |                                   |                                    |
|-------------------------------------|-----------------------------------|------------------------------------|
| 1. STEERING COLUMN                  | 26. SPRING, Upper Bearing         | 51. SCREW, Support                 |
| 2. BEARING ASM                      | 27. PROTECTOR, Wiring             | 52. PIN, Dowel                     |
| 3. PIN, Release Lever               | 28. COVER, Lock Housing (Painted) | 53. SHAFT ASM, Lower Steering      |
| 4. SPRING, Release Lever            | 29. SHIELD, Tilt Lever Opening    | 54. SPHERE, Centering              |
| 5. SPRING, Shoe                     | 30. RETAINER, Spring              | 55. SPRING, Joint Preload          |
| 6. PIN, Pivot                       | 31. SPRING, Wheel Tilt            | 56. SHAFT ASM, Race & Upper        |
| 7. PIN, Dowel                       | 32. GUIDE, Spring                 | 57. SCREW, Wash. Hd.               |
| 8. SHAFT, Drive                     | 33. SCREW, Hex. Washer Head       | 58. SWITCH ASM, Ignition           |
| 9. SHOE, Steering Wheel Lock        | 34. RING, Retaining               | 59. JACKET ASM, Steering Column    |
| 10. SHOE, Steering Wheel Lock       | 35. SECTOR, Switch Actuator       | 60. CLIP, Lower Bearing Adapter    |
| 11. SPRING, Lock Bolt               | 36. HOUSING, Steering Column      | 61. SEAL, Dash                     |
| 12. BOLT, Lock                      | 38. SPRING, Rack Preload          | 62. TUBE ASM, Shift                |
| 13. BEARING ASM                     | 39. RACK, Switch Actuator         | 63. RETAINER, Bearing Adapter      |
| 16. SCREW, Oval Head Cross Recess   | 40. LEVER, Shoe Release           | 64. BEARING ASM                    |
| 17. RACE, Inner                     | 41. ACTUATOR ASM, Ignition Switch | 65. ADAPTER, Lower Bearing         |
| 18. SEAT, Upper Bearing Inner Race  | 43. SPRING, Shift Lever           | 66. RETAINER                       |
| 19. SWITCH ASM, Turn Signal         | 44. WASHER, Wave                  | 77. SCREW, Flat Head               |
| 20. SCREW, Binding HD. Cross Recess | 45. PLATE, Lock                   | 84. SHROUD, Gearshift Bowl         |
| 21. CAM ASM, Turn Sig. Cancelling   | 46. WASHER, Thrust                | 85. BOWL, Gearshift Lever          |
| 22. LOCK, Shaft                     | 47. RING, Shift Tube Retaining    | 86. LOCK CYLINDER SET, Strg Column |
| 23. COVER, Shaft Lock               | 48. SCREW, Oval Head Cross Recess | 87. SCREW, Lock Retaining          |
| 24. NUT, Hexagon Jam                | 49. GATE, Shift Lever             |                                    |
| 25. RING, Retaining                 | 50. SUPPORT, Strg. Column Housing |                                    |

Fig. 3B4-30--Tilt Column With Auto. Trans.

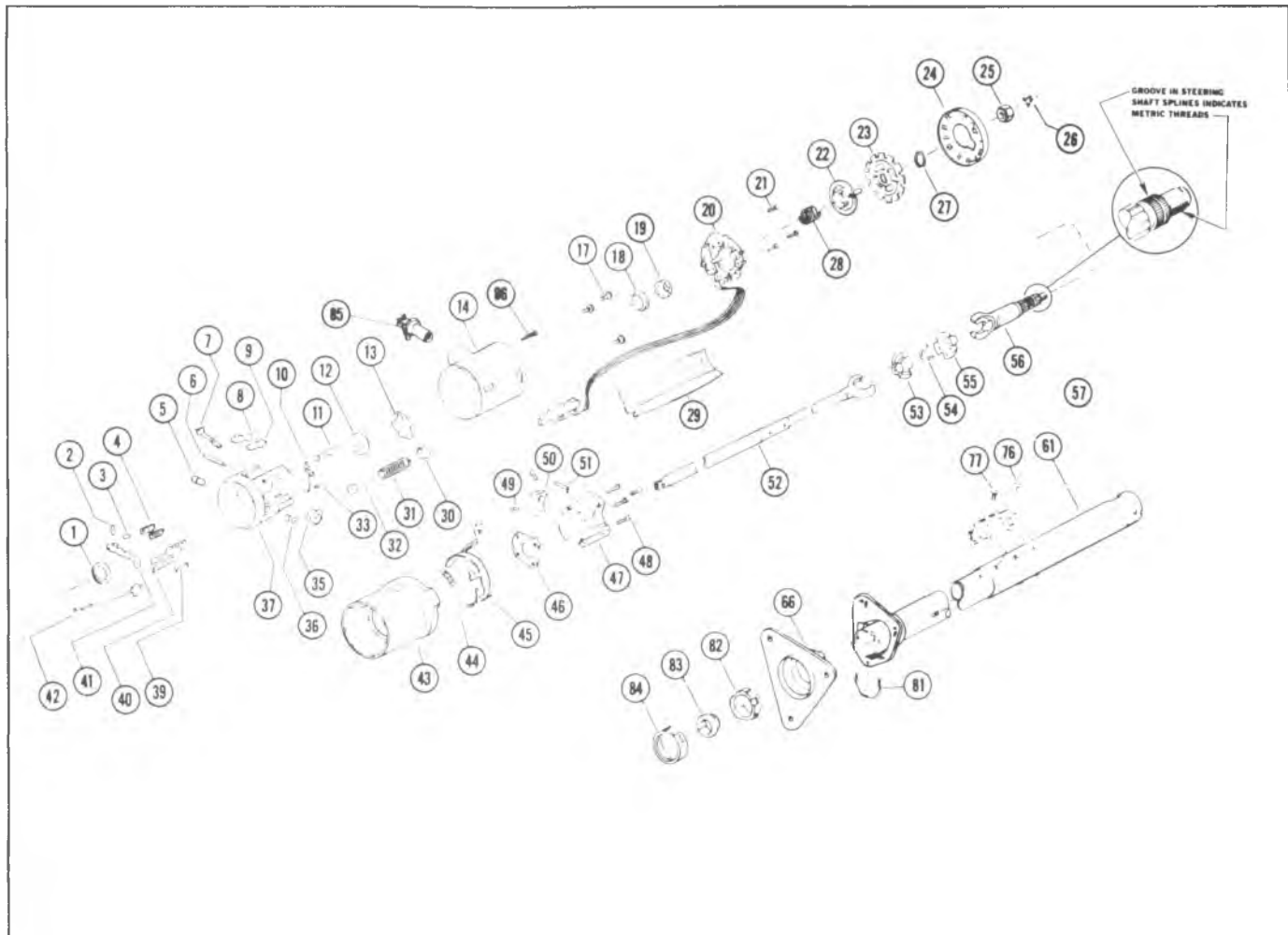

- |                                     |                                      |                                       |
|-------------------------------------|--------------------------------------|---------------------------------------|
| 1. BEARING ASM                      | 26. RETAINER                         | 51. PIN, Dowel                        |
| 2. PIN, Release Lever               | 27. RING, Retainer                   | 52. SHAFT ASM, Lower Steering         |
| 3. SPRING, Release Lever            | 28. SPRING, Upper Bearing            | 53. SPHERE, Centering                 |
| 4. SPRING, Shoe                     | 29. PROTECTOR, Wiring                | 54. SPRING, Joint Preload             |
| 5. PIN, Pivot                       | 30. RETAINER, Spring                 | 55. SPHERE, Centering                 |
| 6. PIN, Dowel                       | 31. SPRING, Wheel Tilt               | 56. SHAFT ASM, Race & Upper           |
| 7. SHAFT, Drive                     | 32. GUIDE, Spring                    | 57. SWITCH ASM, Ignition              |
| 8. SHOE, Steering Wheel Lock        | 33. SCREW, Hex. Washer Head          | 61. JACKET ASM, Sleeve &              |
| 9. SHOE, Steering Wheel Lock        | 35. SECTOR, Switch Actuator          | 62. BEARING ASM, Adapter &            |
| 10. SPRING, Lock Bolt               | 36. PIN, Pivot                       | 63. BEARING ASM                       |
| 11. BOLT, Lock                      | 37. HOUSING, Steering Column         | 64. SPACER, Steering Shaft            |
| 12. BEARING ASM                     | 39. SPRING, Rack Preload             | 65. SEAL, Jacket & Dash Bracket       |
| 13. SHIELD, Tilt Lever Opening      | 40. RACK, Switch Actuator            | 66. BRACKET ASM, Column Dash          |
| 14. COVER, Lock Housing             | 41. LEVER, Shoe Release              | 76. SCREW, Washer Head (#10-24 x .25) |
| 17. SCREW, Oval Head Cross Recess   | 42. ACTUATOR ASM, Switch             | 77. SCREW, Flat Head (#10-24 x .31)   |
| 18. RACE, Inner                     | 43. SHROUD, Column Housing           | 81. CLIP, Lower Bearing Adapter       |
| 19. SEAT, Upper Bearing Inner Race  | 44. SPRING, Key Release              | 82. ADAPTER, Lower Bearing            |
| 20. SWITCH ASM, Turn Signal         | 45. LEVER, Key Release               | 83. BEARING ASM                       |
| 21. SCREW, Binding HD Cross Recess  | 46. PLATE, Lock                      | 84. RETAINER, Bearing Adapter         |
| 22. CAM ASM, Turn Signal Cancelling | 47. SUPPORT, Steering Column Housing | 85. LOCK CYLINDER SET, Strg Column    |
| 23. LOCK, Shaft                     | 48. SCREW, Support                   | 86. SCREW, Lock Retaining             |
| 24. COVER, Shaft Lock               | 49. SCREW, Oval Head Cross Recess    |                                       |
| 25. NUT, Hexagon Jam (9/16-18)      | 50. PLATE, Shroud Retaining          |                                       |

Fig. 3B4-31--Tilt Column With 4-Speed

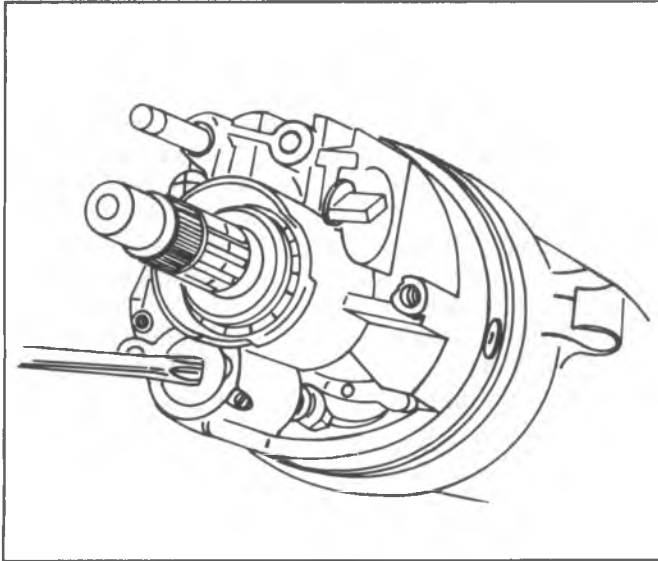

Fig. 3B4-32--Removing Tilt Lever Spring Retainer

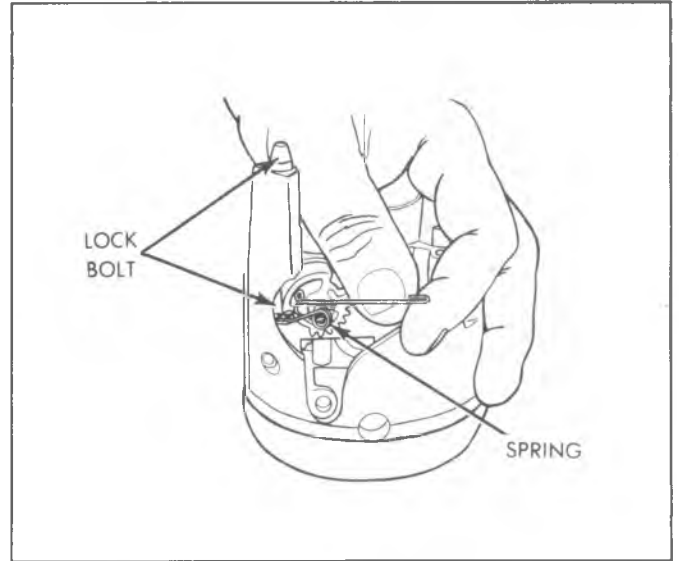

Fig. 3B4-35--Replacing Lock Bolt Spring

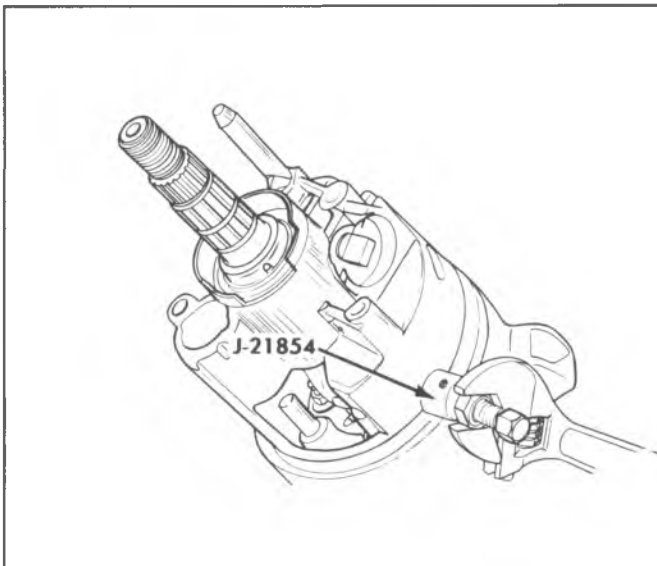

Fig. 3B4-33--Removing Bearing Housing Pivot Pins

2. Mount the column in a vise using both weld nuts of either Set A or B as shown in Figure 3B4-22. The vise jaws must clamp onto the sides of the weld nuts indicated by arrows shown on Set B.

**NOTICE:** Do not place the column in a vise by clamping onto only one weld nut, by clamping onto one weld nut of both Sets A and B or by clamping onto the sides not indicated by arrows, since damage to the column could result.

3. Remove the directional signal switch, lock cylinder and ignition switch as outlined previously in this section.
4. Remove the tilt release lever. Drive out the shift lever pivot pin and remove the shift lever from the housing.
5. Remove the three turn signal housing screws and remove the housing.
6. Install the tilt release lever and place the column in the full "up" position. Remove the tilt lever spring retainer using a #3 Phillips screwdriver that just fits into the slot opening. Insert the Phillips screwdriver in the slot,

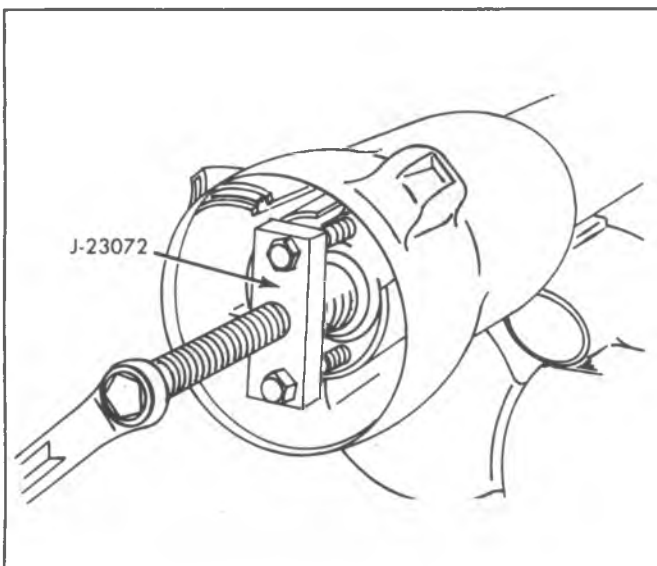

Fig. 3B4-34--Removing Shift Tube

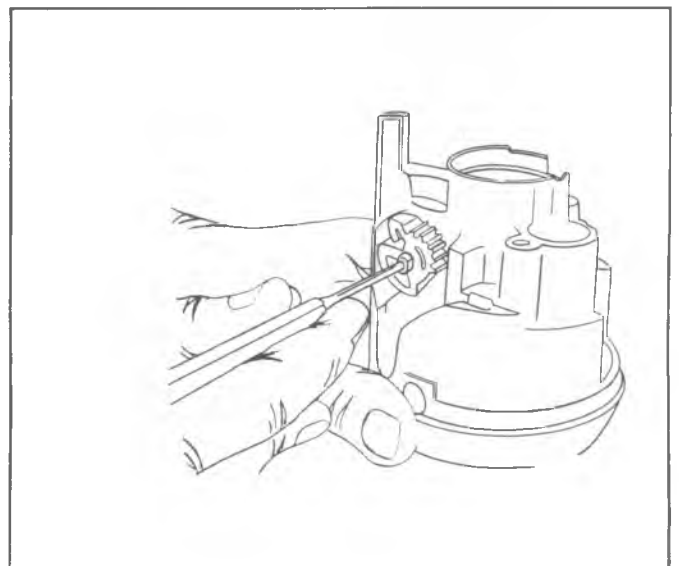

Fig. 3B4-36--Removing Sector Drive Shaft

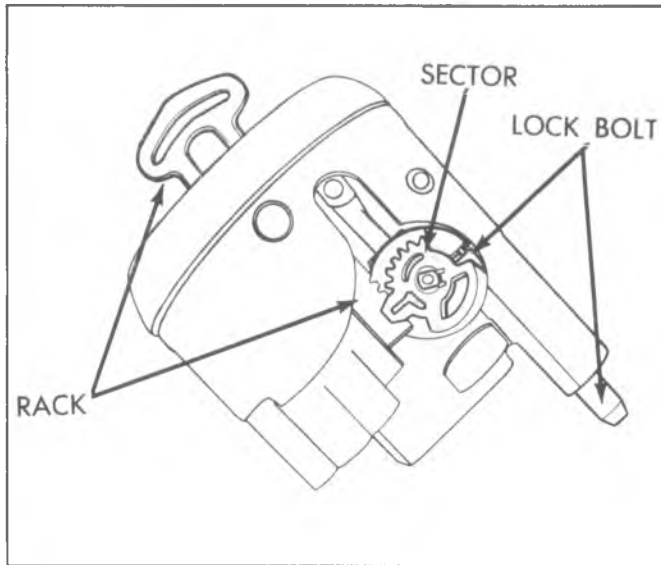

Fig. 3B4-37--Installing Lock Bolt and Rack Assemblies

press in approximately  $3/16$ ", turn approximately  $1/8$  turn counterclockwise until the ears align with the grooves in the housing and remove the retainer, spring and guide (Fig. 3B4-32).

7. Remove the pot joint to steering shaft clamp bolt and remove the intermediate shaft and pot joint assembly. Push the upper steering shaft in sufficiently to remove the steering shaft upper bearing inner race and seat. Pry off the lower bearing retainer clip and remove the bearing reinforcement, bearing and bearing adapter assembly from the lower end of the mast jacket.
8. Remove the upper bearing housing pivot pins using Tool J-21854-1 (Fig. 3B4-33).
9. Install the tilt release lever and disengage the lock shoes. Remove the bearing housing by pulling upward to extend the rack full down, and then moving the housing to the left to disengage the ignition switch rack from the actuator rod.
10. Remove the steering shaft assembly from the upper end of the column.
11. Disassemble the steering shaft by removing the centering spheres and the anti-lash spring.
12. Remove the transmission indicator wire, if so equipped.
13. Remove the four steering shaft bearing housing support to gearshift housing screws and remove the bearing housing support. Remove the ignition switch actuator rod.
14. Remove the shift tube retaining ring with a screwdriver and then remove the thrust washer.
15. Install Tool J-23072 into the lock plate, making sure that the tool screws have good thread engagement in the lock plate. Then, turning the center screw clockwise, force the shift tube from the housing (Fig. 3B4-34). Remove the shift tube (transmission control lock tube on floor shift models) from the lower end of the mast jacket. Remove Tool J-23072.

**NOTICE:** When removing the shift tube, be sure to guide the lower end through the slotted opening in the

mast jacket. If the tube is allowed to interfere with the jacket in any way, damage to the tube and jacket could result.

16. Remove the bearing housing support lock plate by sliding it out of the jacket notches, tipping it down toward the housing hub at the 12 o'clock position and sliding it under the jacket opening. Remove the wave washer.
17. **All Columns** - Remove the shift lever housing from the mast jacket (transmission control lock tube housing on floor shift models). Remove the shift lever spring by winding the spring up with pliers and pulling it out. On floor shift models, remove the spring plunger.
18. Disassemble the bearing housing as follows:
  - a. Remove the tilt lever opening shield.
  - b. Remove the lock bolt spring by removing the retaining screw and moving the spring clockwise to remove it from the bolt (Fig. 3B4-35).
  - c. Remove the snap ring from the sector drive shaft. With a small punch, lightly tap the drive shaft from the sector (Fig. 3B4-36). Remove the drive shaft, sector and lock bolt. Remove the rack and rack spring.
  - d. Remove the tilt release lever pin with a punch and hammer. Remove the lever and release lever spring. To relieve the load on the release lever, hold the shoes inward and wedge a block between the top of the shoes (over slots) and bearing housing.
  - e. Remove the lock shoe retaining pin with a punch and hammer. Remove the lock shoes and lock shoe springs. With the tilt lever opening on the left side and shoes facing up, the four slot shoe is on the left.
  - f. Remove the bearings from the bearing housing only if they are to be replaced. Remove the separator and balls from the bearings. Place the housing on work bench and with a pointed punch against the back surface of the race, carefully hammer the race out of the housing until a bearing puller can be used. Repeat for the other race.

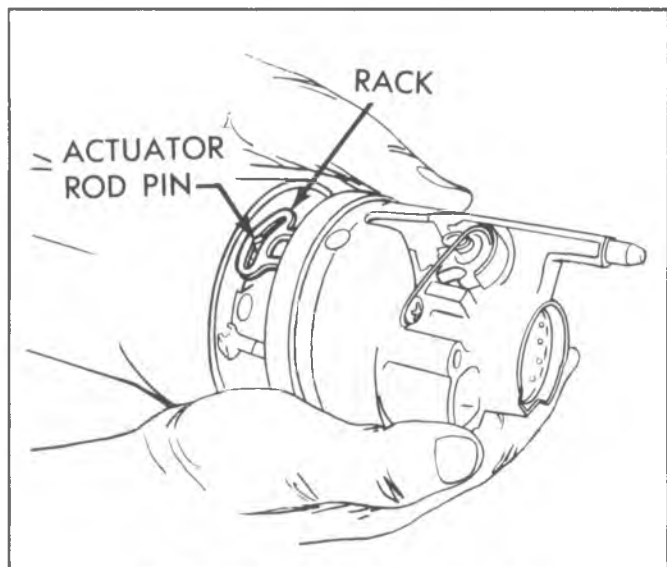

Fig. 3B4-38--Installing Bearing Housing

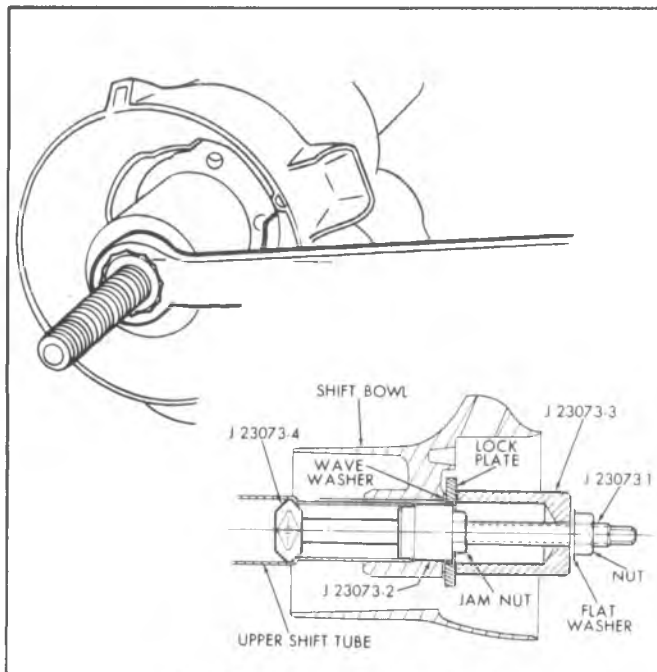

Fig. 3B4-39--Installing Shift Tube

#### Assembly-Tilt Columns

Apply a thin coat of lithium grease to all friction surfaces.

1. If the bearing housing was disassembled, repeat the following steps:
  - a. Press the bearings into the housing, if removed, using a suitable size socket. Be careful not to damage the housing or bearing during installation.
  - b. Install the lock shoe springs, lock shoes and shoe pin in the housing. Use an approximate .180" rod to line up the shoes for pin installation.
  - c. Install the shoe release lever, spring and pin. To relieve the load on the release lever, hold the shoes inward and wedge a block between the top of the shoes (over slots) and bearing housing.
  - d. Install the sector drive shaft into the housing. Lightly tap the sector onto the shaft far enough to install the snap ring. Install the snap ring.
  - e. Install the lock bolt and engage it with the sector cam surface. Then install the rack and spring. The block tooth on the rack should engage the block tooth on the sector (Fig. 3B4-37). Install the external tilt release lever.
  - f. Install the lock bolt spring and retaining screw (Fig. 3B4-32). Tighten the screw to 35 in. lbs.
2. Install the shift lever spring into the housing by winding it up with pliers and pushing it into the housing. On floor shift models, install the plunger, slide the gearshift lever housing onto the mast jacket.
3. Install the bearing support lock plate wave washer.
4. Install the bearing support lock plate. Work it into the notches in the jacket by tipping it toward the housing hub at the 12 o'clock position and sliding it under the jacket opening. Slide the lock plate into the notches in the jacket.
5. Carefully install the shift tube into the lower end of the mast jacket. Align keyway in the tube with the key in the shift lever housing. Install the wobble plate end of Tool J-23073 into the upper end of the shift tube far enough to reach the enlarged portion of the tube. Then install the adapter over the end of the tool, seating it against the lock plate. Place the nut on the threaded end of the tool and pull the shift tube into the housing (Fig. 3B4-39). Remove Tool J-23073.
 

**NOTICE:** Do not push or tap on the end of the shift tube. Be sure that the shift tube lever is aligned with the slotted opening at the lower end of the mast jacket or damage to the shift tube and mast jacket could result.
6. Install the bearing support thrust washer and retaining ring by pulling the shift lever housing up far enough to compress the wave washer.
7. Install the bearing support by aligning the "V" in the support with the "V" in the jacket. Insert the screws through the support and into the lock plate and torque to 60 lbs. in.
8. Align the lower bearing adapter with the notches in the jacket and push the adapter into the lower end of the mast jacket. Install lower bearing, bearing reinforcement and retaining clip, being sure that the clip is aligned with the slots in the reinforcement, jacket and adapter.
9. Install the centering spheres and anti-lash spring in the upper shaft. Install the lower shaft from the same side of the spheres that the spring ends protrude.
10. Install the steering shaft assembly into the shift tube from the upper end. Carefully guide the shaft through the shift tube and bearing.
11. Install the ignition switch actuator rod through the shift lever housing and insert in the slot in the bearing support. Extend the rack downward from the bearing housing.
12. Assemble the bearing housing over the steering shaft and engage the rack over the end of the actuator rod (Fig. 3B4-38).
13. With the external release lever installed, hold the lock shoes in the disengaged position and assemble the bearing housing over the steering shaft until the pivot pin holes line up.
14. Install the pivot pins.
15. Place the bearing housing in the full "up" position and install the tilt lever spring guide, spring and spring retainer. With a suitable screwdriver, push the retainer in and turn clockwise to engage in the housing.
16. Install the upper bearing inner race and race seat.
17. Install the tilt lever opening shield.
18. Remove the tilt release lever, install the turn signal housing and torque the three retaining screws to 45 lbs. in.
19. Install the tilt release lever and shift lever. Drive the shift lever pin in.
20. Install the lock cylinder, turn signal switch and ignition switch as outlined previously in this section.

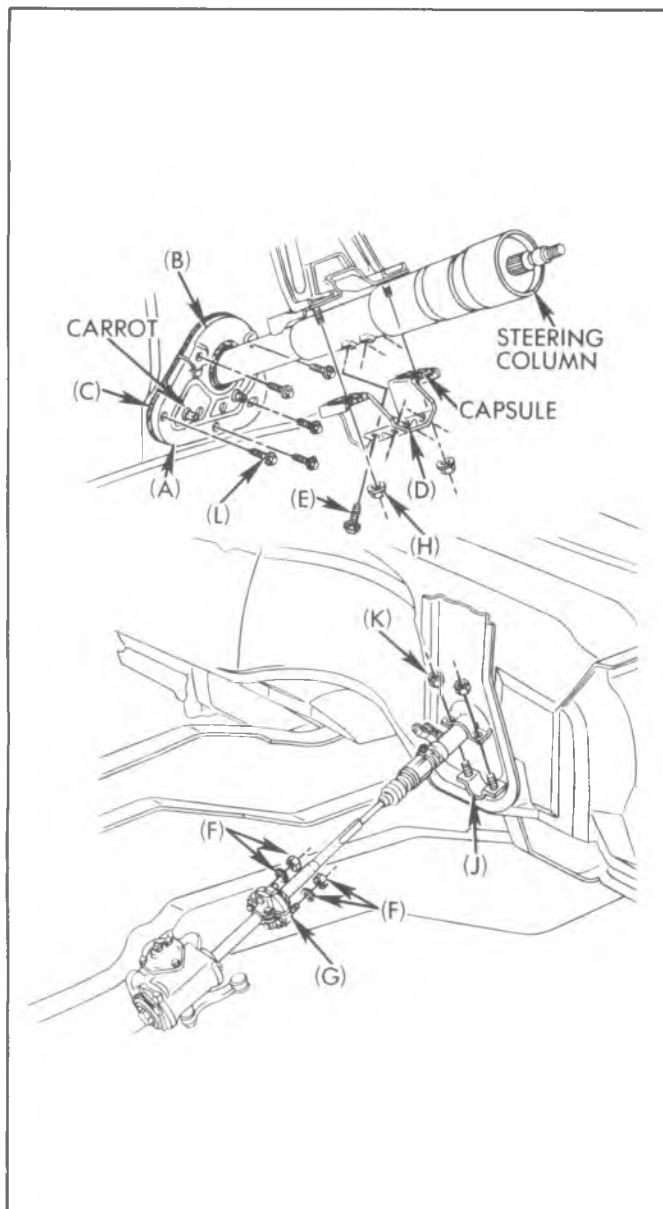

Fig. 3B4-40--Steering Column Installation-CK

21. Align the groove across the upper end of the pot joint with the flat on the steering shaft. Assemble the intermediate shaft assembly to the upper shaft. Install the clamp and bolt and torque the nut to specifications.

**NOTICE:** The clamp bolt must pass through the shaft undercut, or damage may occur to the components.

22. Install the neutral-safety switch or back-up switch as outlined in Section 12 of this manual.
23. Install the four dash panel bracket to column screws and torque to specifications.

**CAUTION:** Be sure that the slotted openings in the bracket (for the mounting capsules) face the upper end of the steering column.

## COLUMN INSTALLATION-MANDATORY SEQUENCE

### Mandatory Preliminary Instructions

1. Assemble lower dash cover (A) and upper dash cover (B) to seal (C) with "Carrots" (part of seal).

2. Attach bracket (D) to jacket and tighten four bolts (E) to specified torque.

### Mandatory Installation Sequence

1. Position column in body and position flange to rag joint and install lock washers and nuts (F) (May be tightened to specified torque at this time). Coupling (G) on manual steering must be installed prior to column installation.
2. Loosely assemble (2) capsules nuts (H) at the instrument panel bracket (D).
3. Position lower clamp (J) and tighten attaching nuts (K) to specified torque.
4. Tighten two nuts (H) at capsules to specified torque.
5. Install seal (C) and covers (A and B) to dash.
6. Install attaching screws (L) and tighten to specified torque.
7. Tighten two nuts (F) at capsules to specified torque if not already done.
8. Remove plastic spacers from flexible coupling pins.
9. Install transmission indicator cable on column automatics.
10. Install the instrument panel trim cover.
11. Connect the transmission control linkage at the shift tube levers.
12. Install the steering wheel as outlined previously in this section.
13. Connect the battery ground cable.

### Mandatory System Requirements

1. Pot joint operating angle must be  $1\ 1/2^\circ \pm 4^\circ$ .
2. Flexible coupling must not be distorted greater than  $\pm .06$  due to pot joint bottoming, in either direction.

## STEERING COLUMN SERVICE FOR G AND P SERIES

### STEERING WHEEL

#### Removal

1. Disconnect battery ground cable.
2. Remove horn button or shroud, receiving cup, Belleville spring and bushing and mark steering wheel to steering shaft relationship.
3. Remove snap ring, and steering shaft nut.
4. Use Tool J-1859-03 to remove wheel (Fig. 3B4-41).

#### Installation

**NOTICE:** See NOTICE on page 1 of this section regarding the fastener referred to in step 2.

**NOTICE:** Directional signal control assembly must be in neutral position when assembling steering wheel to prevent damage to cancelling cam and control assembly.

1. Place the steering wheel onto the steering shaft, aligning the marks made at removal.
2. Position into place and secure to proper torque with nut. Install snap ring.
3. Install horn button assembly.
4. Connect battery ground cable.

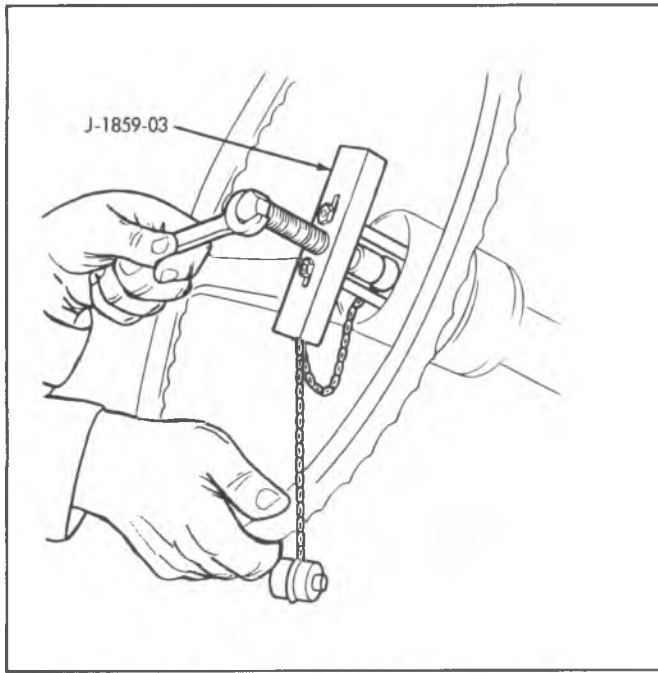

Fig. 3B4-41--Steering Wheel Removal-Typical

**STEERING COUPLING (FLEXIBLE TYPE)**

**Removal (Fig. 3B4-42)**

1. Remove the coupling to steering shaft flange bolt nuts.
2. Remove the coupling clamp bolt. This is a special bolt and will require a 12 pt. socket or box wrench.
3. Remove the steering gear to frame bolts and lower the steering gear far enough to remove the flexible coupling. It is not necessary to disconnect the pitman arm from the pitman shaft.
4. Tap lightly on the flexible coupling with a soft mallet to remove the coupling from the steering gear wormshaft.

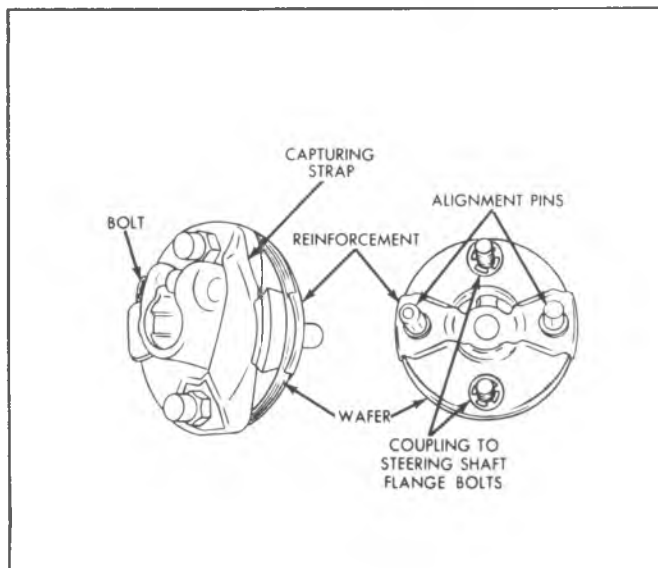

Fig. 3B4-42--Flexible Type Steering Coupling

**Installation**

**NOTICE:** See NOTICE on page 1 of this section regarding the fasteners referred to in steps 2, 4 and 5.

1. Install the flexible coupling onto the steering gear wormshaft, aligning the flat on the shaft with the flat in the coupling. Push the coupling onto the wormshaft until the coupling reinforcement bottoms against the end of the worm.

2. Install the special bolt into the split clamp and torque to specifications.

**NOTICE:** The bolt must pass through the shaft undercut, or damage may occur to the components.

3. Place the steering gear into position, guiding the flexible coupling bolts into the proper holes in the steering shaft flange.
4. Install and tighten the steering gear to frame bolts.
5. Install the coupling to flange bolt nuts and washers and torque to specifications. Be sure to maintain a coupling to flange dimension of .250" to .375". The coupling alignment pins should be centered in the flange slots.

**INTERMEDIATE STEERING SHAFTS WITH POT JOINT COUPLINGS**

**Removal (Fig. 3B4-43)**

1. Remove the lower shaft flange to flexible coupling bolts.
2. Remove upper shaft to intermediate coupling bolt
3. If necessary, remove the steering gear to frame bolts and lower the steering gear far enough to remove the intermediate shaft assembly. It is not necessary to remove the pitman arm from the pitman shaft.

**Disassembly**

1. Mark cover to shaft relationship. Pry off snap ring and slide cover from shaft.
2. Remove bearing blocks and tension spring from pivot pin.
3. Clean grease off pin and end of shaft. Scribe location mark on pin on same side as chamfer in shaft.
4. Supporting shaft assembly securely, with chamfer up, press pin out of shaft with arbor press.

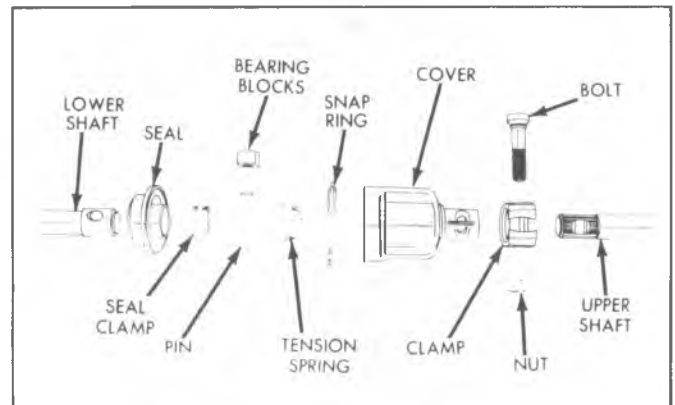

Fig. 3B4-43--Steering Shaft Intermediate Coupling

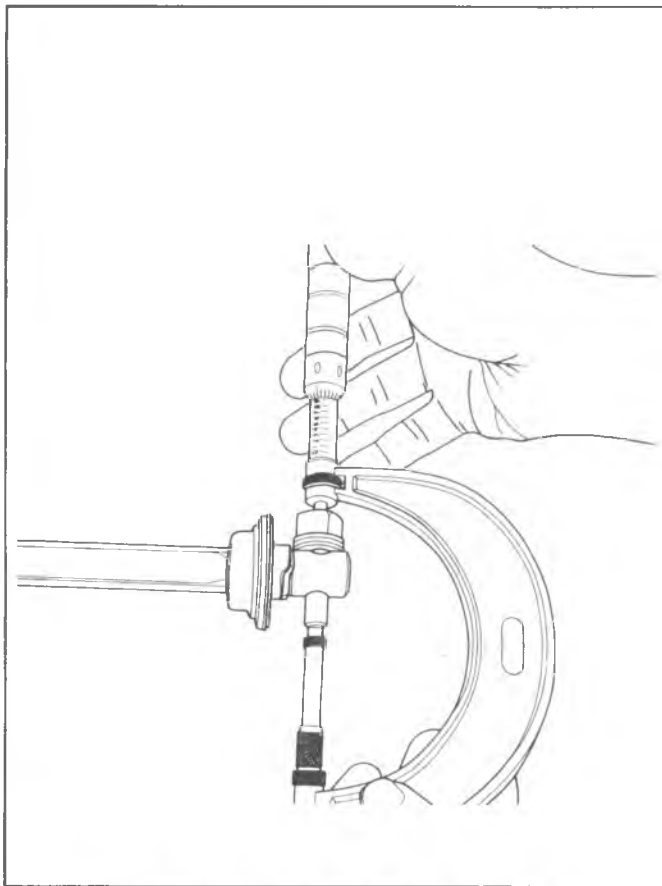

Fig. 3B4-44--Checking Coupling Pin Centering

**NOTICE:** Do not drive pin out with hammer. This may cause sticky or binding bearings when reassembled.

5. Remove seal clamp and slide seal off end of shaft.

#### Assembly

1. Be sure all parts are free of dirt. Slide seal onto steering shaft. With lip of seal against step in shaft clamp seal.
2. Press pin back into shaft from chamfered side. Locate pin in shaft using scribe mark as reference.

**NOTICE:** Pin must be centered within .012 in. or binding in the coupling could result.

3. Check centering of pin (Fig. 3B4-44).
  - a. Place just enough 3/8" flat washers on pin to prevent bearing block from bottoming when installed.
  - b. Measure distance from end of pin to top of bearing with micrometer.
  - c. Remove bearing and washers and place same bearing and washers on other end of pin. Measure distance from end of pin to top of bearing. If micrometer readings in Steps b and c differ more than .012, repeat last part of Step 2 and recheck.
4. Apply a liberal amount of wheel bearing grease to inside and outside of bearing blocks and inside of cover.
5. Position tension spring and bearing blocks on pin.
6. Slide cover over bearing blocks aligning reference mark on cover with mark on shaft. Install seal into end of cover and secure with snap ring retainer.

#### Installation

**NOTICE:** See NOTICE on page 1 of this section regarding the fasteners referred to in steps 1, 3 and 4.

1. Install the intermediate shaft assembly onto the steering shaft, aligning the flat on the shaft with the flat in the coupling. Install the pot joint clamp bolt and torque to specifications.
2. Lift the steering gear into position, guiding the flexible coupling bolts into the shaft flange holes.
3. Install the steering gear to frame bolts and torque to specifications.
4. Install the flexible coupling to steering shaft flange bolt lockwashers and nuts. Check that the coupling alignment pins are centered in the flange slots and then torque the coupling bolts to specifications.

#### INTERMEDIATE STEERING SHAFT WITH UNIVERSAL JOINT COUPLINGS

##### Removal (Fig. 3B4-43)

1. Set front wheels in straight ahead position. This can be done by driving the vehicle a short distance on a flat surface.
2. Mark upper universal joint yoke to steering shaft relationship and lower yoke to steering gear wormshaft relationship.
3. Remove both upper and lower universal yoke pinch bolts.
4. Remove steering gear to frame bolts and lower the gear. It is not necessary to disconnect the pitman arm from the steering gear pitman shaft.
5. Remove the intermediate steering shaft and universal joint assembly.

##### Disassembly

1. If the upper or lower half of the intermediate steering shaft is to be replaced, proceed as follows:
  - a. With the shaft assembly on a bench, straighten the tangs on the dust cap. Separate the upper and

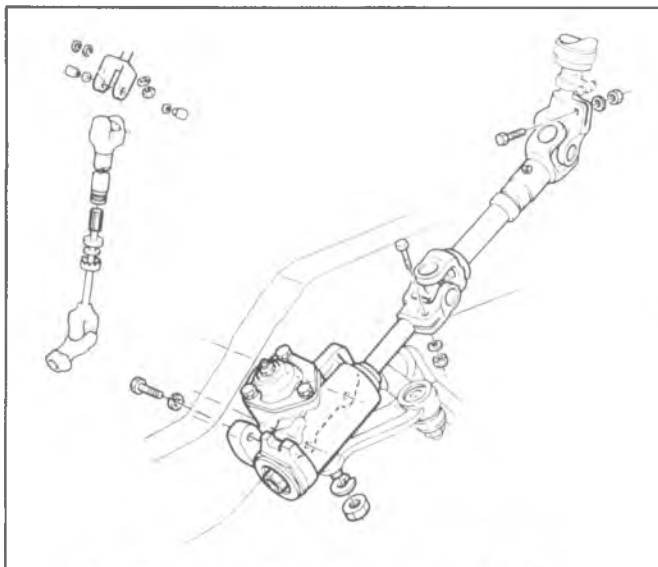

Fig. 3B4-45--Intermediate Steering Shaft-P Series



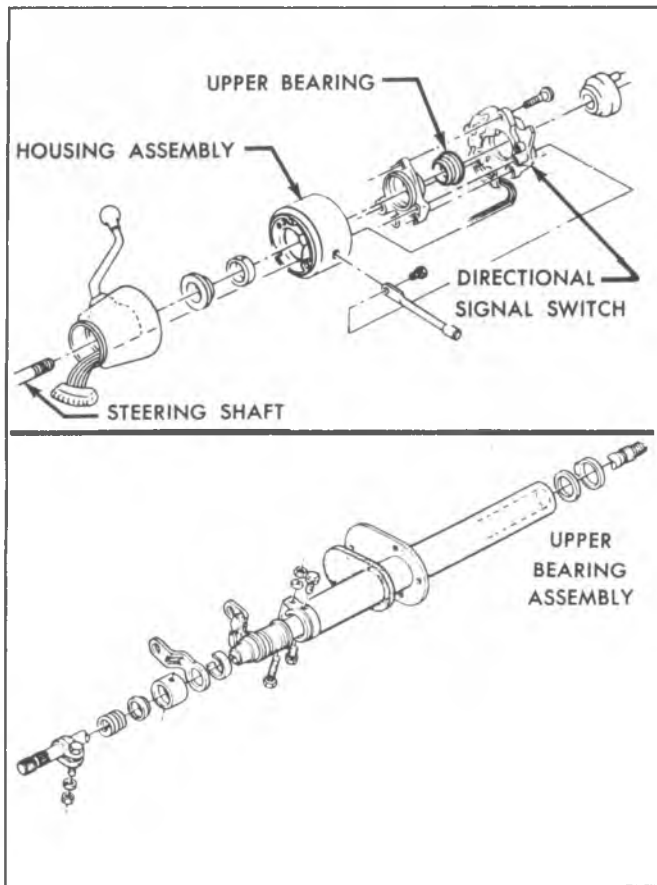

Fig. 3B4-46--Steering Column Upper Bearing

lower portions of the shaft assembly.

- b. Remove the felt washer, plastic washer and dust cap. Discard the felt washer.
2. If the trunion assemblies are to be replaced, proceed as follows:
  - a. Remove the snap rings retaining the trunion bushings in one of the yokes.
  - b. Support the yoke on a bench vise and drive out one bushing by tapping on the opposite bushing using a soft drift and hammer.
  - c. Support the other side of the yoke and drive out the remaining bushing as in Step b above.
  - d. Move the yoke on the trunion as necessary to separate the upper and lower yokes.
  - e. Remove the trunion from the lower yoke as outlined in Steps a through d above. Remove and discard the seals.

#### Assembly

1. If the yoke trunnions were removed, reassemble as follows:
  - a. Place the new trunion into the lower yoke.
  - b. Place new seals onto the trunion and then press the new bushings into the yoke and over the trunion hubs far enough to install the snap rings.
  - c. Install the snap rings.
  - d. Repeat Steps a through c to attach the upper yoke to the trunion.
2. Reassemble the intermediate shaft assembly as follows:

- a. Place the dust cap, plastic washer and a new felt seal over the shaft on the lower yoke assembly.
- b. Align the arrow on the lower yoke assembly shaft with the arrow on the upper yoke assembly tube and push the two assemblies together.
- c. Push the dust cap, plastic washer and felt washer into position on the lower end of the upper yoke assembly and bend the tangs of the dust cap down against the yoke tube.

#### Installation

**NOTICE:** See NOTICE on page 1 of this section regarding the fasteners referred to in steps 1, 3 and 4.

1. Align the marks made at removal and assemble the intermediate shaft lower yoke onto the steering gear wormshaft. Install the pinch bolt and torque to specifications. The pinch bolt must pass through the shaft undercut. If a new yoke was installed, the slit in the yoke should be in the 12 o'clock position.
2. Raise the steering gear into position while guiding the upper yoke assembly onto the steering shaft. The marks on the coupling and steering shaft must align. If a new yoke was installed, assemble the upper yoke to the steering shaft with the steering wheel in straight ahead position (gear must be on high point).
3. Install the steering gear to frame bolts and torque to specifications.
4. Install the upper yoke to steering shaft pinch bolt and torque to specifications.

**NOTICE:** The pinch bolt must pass through the shaft undercut, or damage may occur to the components.

### STEERING COLUMN UPPER BEARING-G AND P SERIES

#### Standard Column

##### Removal

1. Remove steering wheel as outlined in this section.
2. Remove directional signal cancelling cam.
3. Pry out upper bearing.

##### Installation

**NOTICE:** See NOTICE on page 1 of this section regarding the fasteners referred to in step 1.

1. Replace all component parts in reverse order of removal making sure that directional switch is in neutral position before installing steering wheel. Torque steering wheel nut to specifications.

#### Tilt Column

The upper bearings on the tilt column are spun into the bearing housing assembly. If the bearings indicate need of replacement, the entire bearing housing must be replaced. See "Tilt Steering Column - Disassembly and Assembly" for the correct replacement procedure.

### STEERING COLUMN LOWER BEARING P SERIES

##### Removal

1. Remove the intermediate steering shaft and universal joint assembly as outlined earlier in this section. Remove the preload spring clamp and spring

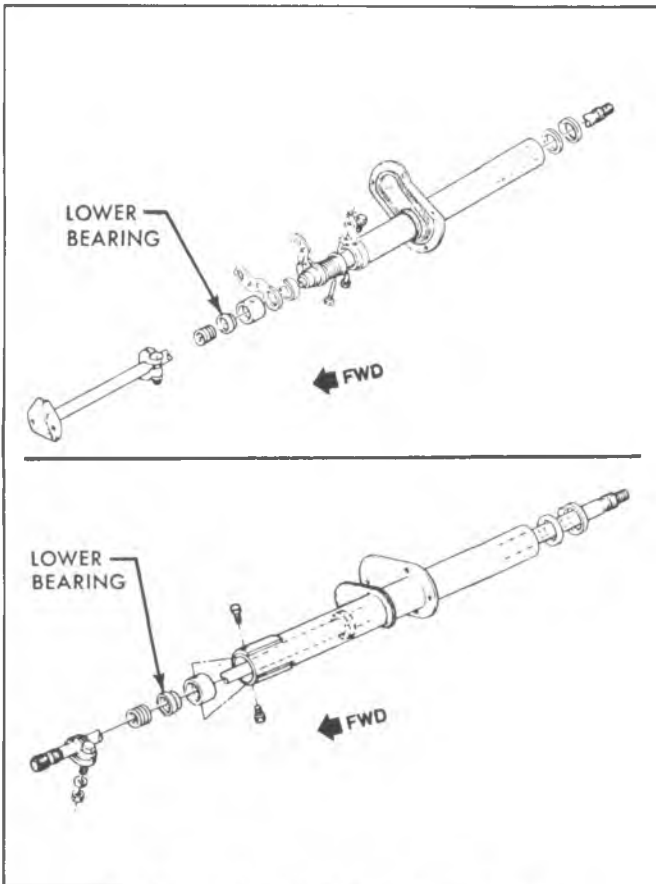

Fig. 3B4-47--Steering Column Lower Bearing

from the end of the steering shaft.

2. Pry out the lower bearing assembly.

#### Installation

**NOTICE:** See NOTICE not on page 1 of this section regarding fasteners referred to in step 2.

1. Place the new bearing over the end of the steering shaft and press into position in the column.
2. Install the preload spring and clamp and torque the clamp bolt nut to specifications. Refer to "Bearing Adjustment" in "Maintenance and Adjustment Section. Reinstall the intermediate shaft and universal joint assembly as outlined under "Intermediate Steering Shaft with Universal Joint Couplings - Installation".

### TILT COLUMN BEARING HOUSING ASSEMBLY - G AND P SERIES

#### Removal (Column in Vehicle)

1. Disconnect the battery ground cable.
2. Remove the steering wheel as outlined under "Steering Wheel - Removal".
3. Remove the directional signal switch as outlined under "Directional Signal Switch - Removal".
4. **Column Shift Models** - Using a suitable size punch, drive out the shift lever pivot pin and remove the shift lever.
5. Install the tilt release lever and place the column in the full "up" position. Remove the tilt lever spring and

retainer using a screwdriver that just fits into the slot opening. Insert the screwdriver into the slot, push in approximately 3/16", rotate clockwise approximately 1/8 turn until the retainer ears align with the grooves in the housing and remove the retainer and spring.

6. Remove the steering shaft bearing locknut using Socket J-22599. Remove the upper bearing race seat and race.
7. Remove the two bearing housing pivot pins using Tool J-21854.
8. Pull up on the tilt release lever (to disengage the lock shoes) and remove the bearing housing.

If the bearing housing is being replaced or it is necessary to disassemble the bearing housing, proceed as follows:

- a. Press the upper and lower bearings out of the housing.
- b. Using Puller J-5822 and Slide Hammer J-2619, pull the bearing races from the housing.
- c. Remove the tilt release lever.
- d. Drive out the shoe release pivot pin using Tool J-22635 or a suitable punch. Remove the lever spring and remove the wedge.
- e. Using a suitable size punch, drive out the lock shoe retaining pin. Remove the shoes and shoe springs.

If the upper steering shaft, lower steering shaft, or centering spheres are being removed, proceed as follows:

9. To remove the steering shaft assembly through the upper end of the column. If it is necessary to

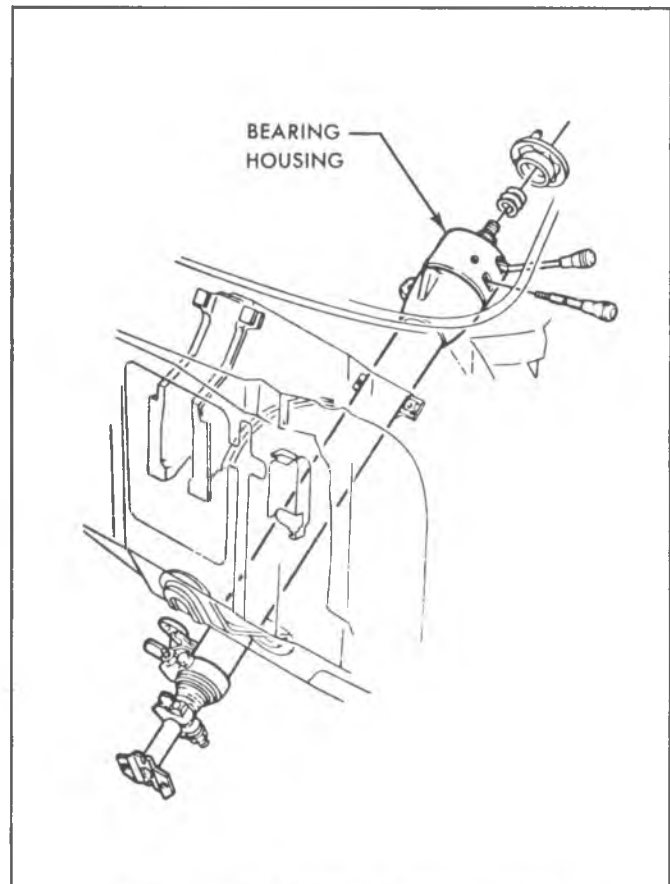

Fig. 3B4-48--Tilt Column Bearing Housing

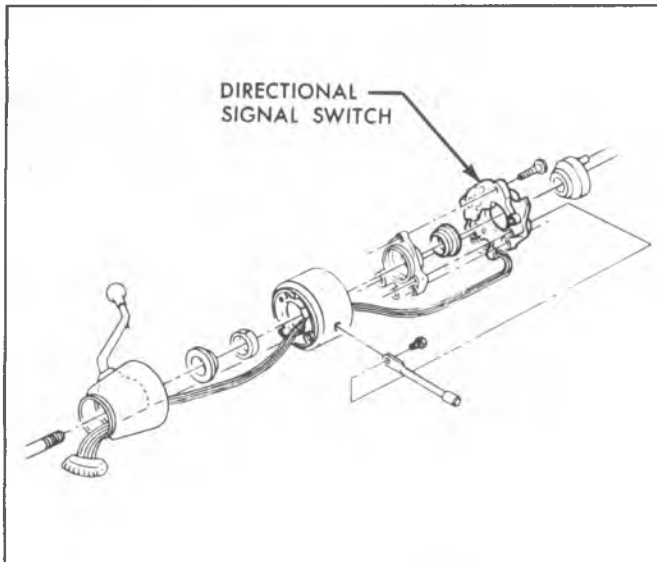

Fig. 3B4-49--Directional Signal Switch

disassemble the shaft, proceed as follows:

- a. To remove the lower steering shaft first disconnect the shaft at the pot joint coupling clamp.
- b. Turn the upper shaft 90° to the lower shaft and slide the upper shaft and centering spheres from the lower shaft.
- c. Rotate the centering spheres 90° and remove the centering spheres and preload spring from the upper shaft.

If the bearing housing support is being replaced, proceed as follows:

10. Remove the four bearing housing support screws and remove the support.

#### Assembly

**NOTICE:** See NOTICE on page 1 of this section regarding the fasteners referred to in steps 3, 9 and 11.

1. Assemble the steering shaft as follows:
  - a. Lubricate and assemble the centering spheres and preload spring.
  - b. Install the spheres into the upper (short) shaft and rotate 90°.
  - c. Install the lower shaft 90° to the upper shaft and over the centering spheres. Slowly straighten the shafts while compressing the preload spring.
2. Install the shaft assembly into the housing from the upper end.
3. Install the lower shaft to the pot joint coupling clamp. Install the coupling clamp bolt and torque to specifications.

**NOTICE:** The coupling bolt must pass through the shaft undercut, or damage may occur to the components.

4. Assemble the bearing housing as follows:
  - a. Press the new upper and lower bearing races into the bearing housing.
  - b. Lubricate and install the bearings into the bearing races.

- c. Place the lock shoe springs in position in the housing. Install each shoe in place and compress the spring until a suitable size straight punch can be used to hold the shoe in position (it may be necessary to acquire assistance to install the shoes). Once the shoes are in place, drive in the shoe retaining pin.
  - d. Install the shoe release lever and drive in the pivot pin.
  - e. Install the tilt release lever.
  - f. Lubricate the shoes and release lever.
5. Install the bearing housing assembly to the support. Hold the tilt release lever in the "up" position until the shoes have fully engaged the support. Lubricate and install the bearing housing pivot pins. Press the pins in flush with the housing.
  6. Place the housing in the full "up" position and then install tilt spring and retainer (tapered end of spring first). Push into the housing approximately 3/16" and rotate counterclockwise 1/8 turn.
  7. Lubricate and install the upper bearing race, race seat and locknut. Tighten the locknut (using Socket J-22599) to remove the lash and then carefully further tighten 1/16 to 1/8 of a turn (column must be in straight ahead position).
  8. Remove the tilt release lever.
  9. Install the directional signal switch as outlined under "Directional Signal Switch - Installation".
  10. Column Shift Models - Install the shift lever and pivot pin.
  11. Install the steering wheel as outlined under "Steering Wheel - Installation".
  12. Check electrical and mechanical functioning of column.

#### DIRECTIONAL SIGNAL SWITCH

If the directional signal switch must be replaced, the steering column does not have to be removed from the vehicle.

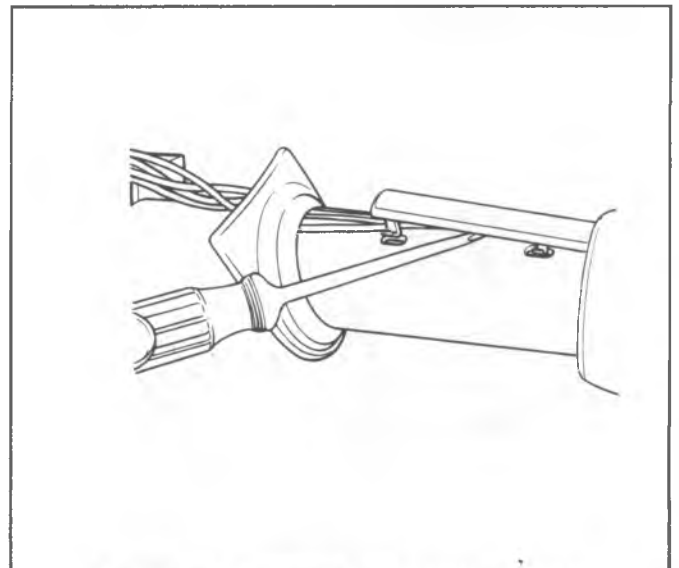

Fig. 3B4-50--Removing Wiring Harness Protector

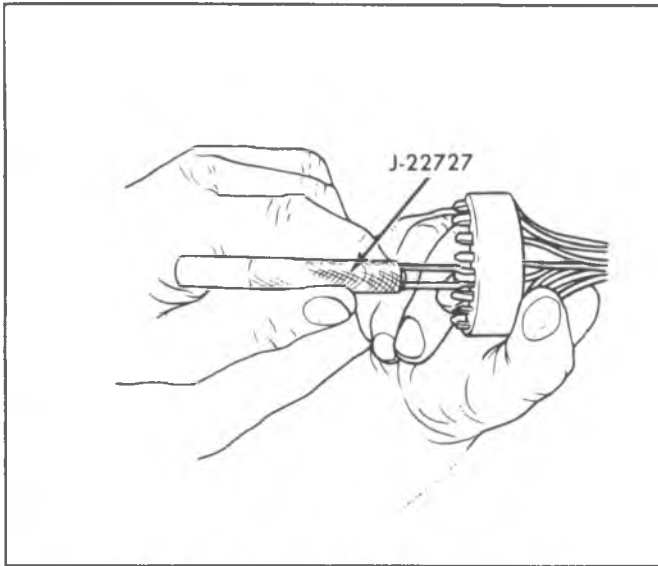

Fig. 3B4-51--Removing Wires from Connector

### Removal

1. Remove the steering wheel as outlined under "Steering Wheel - Removal".
2. Remove the directional signal switch cancelling cam and spring.
3. Remove the column to instrument panel trim plate (if so equipped).
4. Disconnect the directional signal switch wiring harness at the half-moon connector.
5. Pry the wiring harness protector out of the column retaining slots as shown in Figure 3B4-50.
6. Mark the location of each wire in the half-moon connector and then remove each individual wire from the connector using Tool J-22727 (Fig. 3B4-51). Insert the tool into the lower end of the connector and push in until the tool bottoms on the connector. Remove the tool and then pull the wire from the connector.
7. Remove the directional signal lever screw and remove the lever.

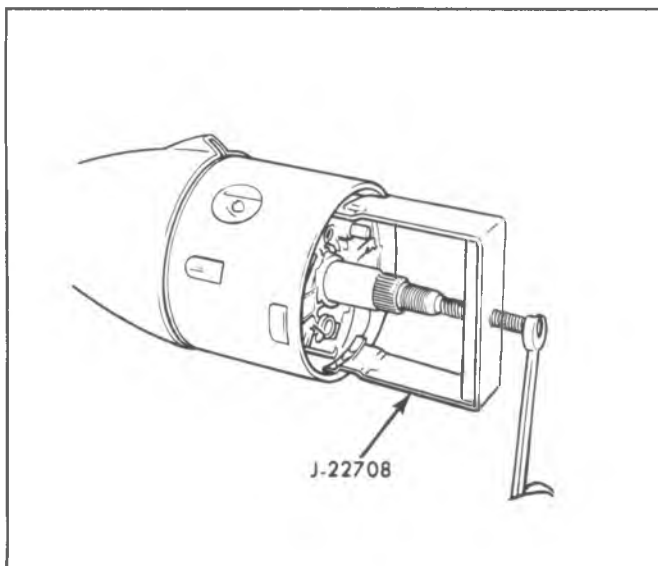

Fig. 3B4-52--Removing Directional Signal Housing Cover

8. Push in on the hazard warning light knob and then unscrew and remove the knob.
9. **Tilt Columns Only**
  - a. Automatic Transmission Models - Remove the PRNDL dial screws and remove the dial and indicator needle. Remove the cap and dial illumination bulb from the housing cover.
  - b. Unscrew and remove the tilt release lever.
  - c. Assemble Tool J-22708 inside the directional signal housing cover; push in until the tangs lock inside the cover flange (Fig. 3B4-52). Turn the tool center screw clockwise to pull the cover from the housing.
10. Remove the three directional signal switch mounting screws and then carefully remove the switch assembly from the column while guiding the wiring harness through the opening in the shift lever housing.

### Installation

**NOTICE:** See NOTICE on page 1 of this section regarding the fasteners referred to in step 9.

1. Wrap the ends of the directional signal switch wires with tape and then guide them through the opening at the lower left hand side of the bearing housing (tilt columns), out the lower end of the shift lever housing and under the dash seal.
2. Place the directional signal switch in position and install the three mounting screws; torque to 25 lbs. in. after screw head has been firmly seated.
3. **Tilt Columns Only-**
  - a. Align the openings in the directional signal switch cover with the proper lever positions and tap the cover into place using a plastic hammer.
  - b. Install the tilt release lever.
  - c. Automatic Transmission Model - Install the PRNDL dial, pointer, dial illumination bulb and cap.
4. Install the directional signal switch lever and hazard warning knob.
5. Bend the wire retaining tabs slightly outward on each wire in the wiring harness as shown in Figure

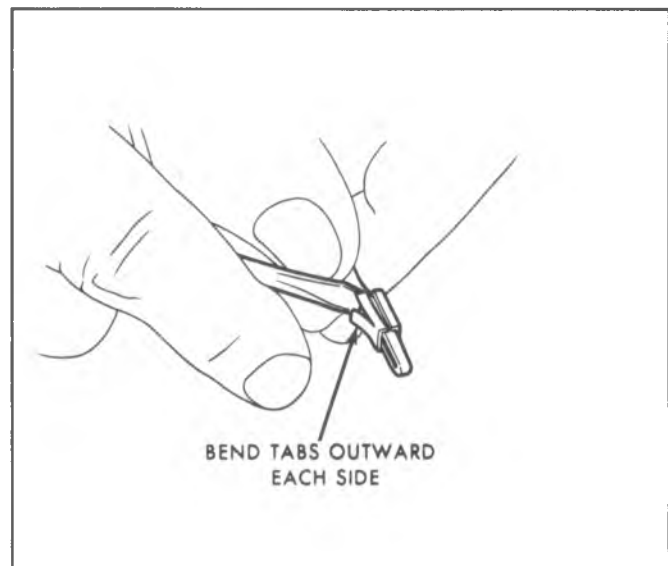
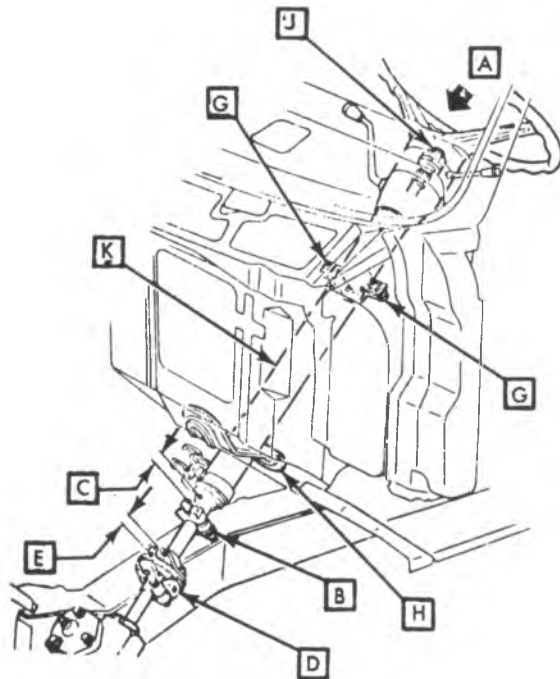

Fig. 3B4-53--Preparing Wire Retaining Tabs for Installation



#### STEERING SYSTEM MANDATORY REQUIREMENTS

1. Using a 50 lb. force applied to the steering wheel end of Shaft **A**, Lower Clamp Nut **B** must be tightened to the specified torque to give a compressed spring dimension **C** of  $.50 \pm .04$  after assembly.
2. Flexible Coupling **D** setup dimension **E** must be  $.250/.375$ . **NOTICE** This dimension must be held to prevent distortion of Flexible Coupling with resultant bind and harshness.
3. All Mast Jacket attachments **G** & **H** must be tightened to recommended torque.
4. Threaded portion of Steering Shaft **J** must be completely free of lubricant after Mast Jacket **K** assembly to maintain steering wheel clamping load and hub clearance.

Fig. 3B4-54--Steering Column Attachment-G Series

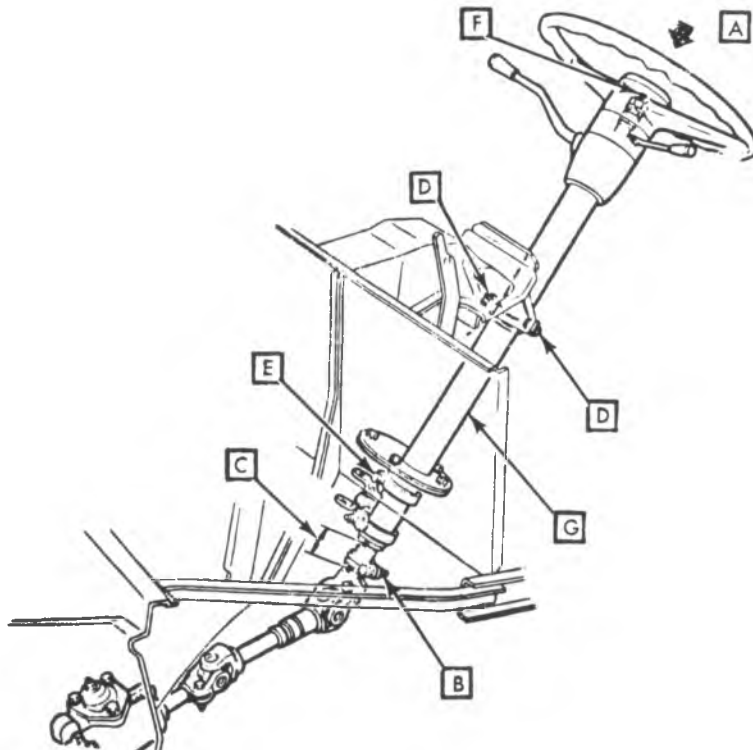

#### STEERING SYSTEM MANDATORY REQUIREMENTS

1. Using a 50 lb. force applied to the steering wheel end of Shaft **A**, Lower Clamp Nut **B** must be tightened to the specified torque to give a compressed spring dimension **C** of  $1.26 \pm .02$  after assembly.
2. All Mast Jacket attachments **D** & **E** must be tightened to recommended torque.
3. Threaded portion of Steering Shaft **F** must be completely free of lubricant after Mast Jacket **G** assembly to maintain steering wheel clamping load and hub clearance.

Fig. 3B4-55--Steering Column Attachment - P Series

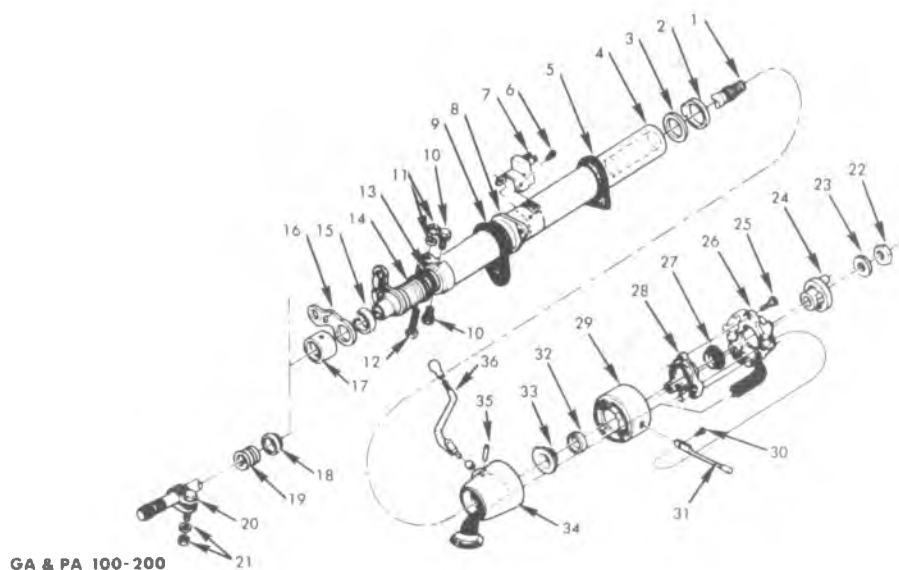

GA &amp; PA 100-200

- |                                 |                                  |                                    |
|---------------------------------|----------------------------------|------------------------------------|
| 1. Upper Steering Shaft         | 13. Shift Tube Felt Washer       | 25. Turn Signal Switch Screw       |
| 2. Shift Housing Bushing        | 14. Shift Tube Assembly          | 26. Turn Signal Switch             |
| 3. Bushing Seat                 | 15. Shift Lever Spacer           | 27. Steering Shaft Upper Bearing   |
| 4. Mast Jacket                  | 16. 1st-Reverse Shift Lever      | 28. Switch Contact Support         |
| 5. Column Cover                 | 17. Adjusting Ring               | 29. Turn Signal Housing            |
| 6. Back-Up Lamp Switch Screw    | 18. Shaft Lower Bearing          | 30. Turn Signal Switch Lever Screw |
| 7. Back-Up Lamp Switch          | 19. Lower Bearing Preload Spring | 31. Turn Signal Switch Lever       |
| 8. Toe Pan Seal Retainer        | 20. Preload Spring Clamp         | 32. Rubber Ring                    |
| 9. Toe Pan Seal                 | 21. Nut and Lockwasher           | 33. Plastic Thrust Washer          |
| 10. Adjusting Ring Clamp Screws | 22. Steering Shaft Nut           | 34. Shift Lever Housing            |
| 11. Nut and Lockwasher          | 23. Lockwasher                   | 35. Shift Lever Pin                |
| 12. Adjusting Ring Clamp Bolt   | 24. Turn Signal Cancelling Cam   | 36. Shift Lever                    |

Fig. 3B4-56--Standard Column-Typical G &amp; P

- 3B4-53; this will provide proper retention of the wire in the half-moon connector.
- Install each wire in its marked location in the half-moon connector. Push in until square part of clip is flush with the bottom side of the connector. Connect the directional signal switch wiring harness.
  - Snap the wiring harness protector into the column retaining slots.
  - Install the directional signal cancelling cam and spring.
  - Install the steering wheel as outlined under "Steering Wheel - Installation".
  - Install the column to instrument panel trim plate (if so equipped).

## STEERING COLUMN G AND P SERIES

### Removal

- Disconnect the battery ground cable.
- Column Shift Models - Disconnect transmission shifter rods at the lower end of the column.
- G Models** - Remove the intermediate steering shaft flange to flexible coupling bolts.  
**P Models** - Remove the intermediate steering shaft upper universal yoke to steering shaft pinch bolt. Mark the coupling to shaft relationship.
- Remove column clamp screw(s) on engine side of firewall, if equipped, and remove or slide the clamp down the column.
- From inside the vehicle, remove the screws from the toe pan cover and slide the cover and seal up the column.
- Remove the steering wheel as outlined under "Steering Wheel-Removal", and reinstall the shaft nut and washer.
- All Columns - Disconnect the directional signal wiring harness. Standard Column with Automatic Transmission - Disconnect the conductor tube (for transmission indicator) at the instrument panel.  
Tilt Column with Automatic Transmission - Disconnect the single wire at the fuse block and unclip it from the parking brake bracket.

8. Remove the cap screws from the column support bracket at the dash panel.
9. Carefully lower and then withdraw the column assembly, rotating so that the shift levers clear the toe pan opening.

#### Disassembly of Standard Column (Fig. 3B4-56)

For floor shift transmission models, omit Steps 4, 14, 15 and 16.

1. Remove the steering wheel nut and lock washer and then slide the steering shaft assembly from the lower end of the column.
2. G Models - Remove the lower bearing preload spring and clamp from the steering shaft.  
P Models - Remove the lower bearing preload spring and clamp.
3. Remove the back-up lamp switch.
4. Drive out the shift lever pivot pin and remove the shift lever.
5. Remove the directional signal cancelling cam. Remove the directional signal switch lever.
6. Remove the column wiring harness cover.
7. Remove the directional signal switch screws.
8. Rotate the directional signal switch housing counterclockwise and remove the housing from the column. The housing and switch cannot be fully removed from the column until the shift lever housing is removed.
9. Remove the plastic thrust washer assembly and then remove the shift lever housing (or extension housing) from the column.
10. Separate the directional signal switch, switch control support assembly, directional signal housing and shift lever housing (or housing extension) assemblies.
11. Press the steering shaft upper bearing out of the switch contact support.
12. Remove the shift lever housing (or extension housing) seat and bushing from the upper end of the column.
13. Remove the bolt and screws from the adjusting ring clamp and remove the clamp, adjusting ring and lower bearing. Press the lower bearing out of the adjusting ring.
14. 3-Speed Columns - Remove 1st-reverse shift lever and lever spacer.  
Automatic Columns - Remove the selector plate clamping ring screws (3).
15. Place the column upright on the floor, supporting it with two pieces of wood. Place a block of wood on the upper end of the shift tube. Press down on the shift lever with foot while tapping on the wood block to withdraw the tube from the column jacket.  
**NOTICE:** In some tolerance stack-up cases it may be necessary to use a press. Be careful not to damage the tube or jacket.
16. Remove the felt seal from the shift tube.
17. Remove firewall clamp, toe pan seal and dash panel seals from the jacket.

#### Assembly

In the following assembly sequence use any general purpose lithium soap grease for lubricating those components so indicated.

1. Install the dash panel seal, toe panel and firewall clamps over the end of the jacket.
2. Lubricate all bearing surfaces on the shift tube.
3. Place the felt seal onto the shift tube (next to spring) and then place the shift tube in the jacket.
4. 3-Speed Columns - Temporarily install spacer, 1st-reverse shift lever and lower adjusting ring. Place a block of wood on top of the adjusting ring and tap until the shift tube bottoms. Remove adjusting ring, shift lever and spacer.  
Automatic Columns - Align the three holes in the selector plate with the three holes in the jacket, position the clamping ring and install the three screws. The shift tube spring retainer must be bottomed against the jacket stops.
5. 3-Speed Columns - Lubricate and install the spacer and 1st-reverse shift lever (tang of lever towards top of column).
6. Install lower bearing in the adjusting ring and then install the adjusting ring, clamp and screws.
7. Install the shift lever housing (or extension housing) seat and bushing to upper end of housing.
8. Thread directional signal switch wiring harness through the switch and lever (or extension) housings, lubricate the inner diameter of the shift housing, and then place the shift lever (or extension) housing onto the upper end of the column.
9. Install the switch housing plastic washer assembly. Press the upper bearing into the switch contact support.
10. Install the directional signal switch housing, contact support, bearing and switch and torque the switch screws to 25 lbs. in.
11. Install the column wiring harness cover and back-up lamp switch.
12. Install the directional signal and gearshift levers.
13. Adjust the shift tube as outlined under "Shifter Tube Adjustment."
14. Loosely install the lower bearing preload spring and clamp.
15. Slide the steering shaft assembly up through the column assembly. Install the directional signal cancelling cam, steering shaft nut and lock washer.

#### Disassembly Of Tilt Column (Fig. 3B4-57)

1. If the column is removed from the vehicle, place the column in a bench vise using Holding Fixtures J-22573 (Fig. 3B4-58).

**NOTICE:** Clamping the column directly in a vise, could result in a damaged column.

2. Remove the directional signal switch as outlined under "Directional Signal Switch-Removal".

3. Remove the lower steering shaft and pot joint assembly and lower bearing and adapter assembly as outlined under "Lower Bearing and Adapter-Removal".
4. Column Shift Models - Using a suitable size punch, drive out the shift lever pivot pin and remove the shift lever.
5. Install the tilt release lever and place the column in the full "up" position. Remove the tilt lever spring and retainer using a screwdriver that just fits into the slot opening (Fig. 3B4-59). Insert the screwdriver clockwise approximately 1/8 turn until the retainer ears align with the grooves in the housing and remove the retainer and spring.
6. Remove the steering shaft bearing locknut using socket J-22599. Remove the upper bearing race seat and race.
7. Remove the two bearing housing pivot pins using Tool J-21854 (Fig. 3B4-60).
8. Pull up on the tilt release lever (to disengage the lock shoes) and remove the bearing housing. If it is necessary to disassemble the bearing housing, proceed as follows:
  - a. Press the upper and lower bearings out of the housing.
  - b. Using Puller J-5822 and Slide Hammer J-2619 pull the bearing races from the housing (Fig. 3B4-61).
  - c. Remove the tilt release lever.
  - d. Drive out the shoe release lever pivot pin using Tool J-22635 or a suitable punch (Fig. 3B4-62). Remove the lever spring and remove the wedge.
  - e. Using a suitable size punch, drive out the lock shoe retaining pin. Remove the shoes and shoe springs.
9. Remove the steering shaft assembly through the upper end of the column. If it is necessary to disassemble the shaft proceed as follows:
  - a. Turn the upper shaft 90° to the lower shaft and slide the upper shaft and centering spheres from the lower shaft.
  - b. Rotate the centering spheres 90° and remove the center spheres and preload spring from the upper shaft.
10. Remove the four bearing housing support screws and remove the support.
 

Column Shift Models - If the shift tube index plate must be removed, remove the two retaining screws and remove the plate.
11. Remove the shift tube retaining ring with a screwdriver (Fig. 3B4-63). Remove the thrust washer.
12. Remove the neutral-safety or back-up lamp switch screws and remove the switch.
13. Rework Shift Tube Removing Tool J-22551 by removing 1/2" from the pilot end of the tool (Fig. 3B4-

64). This allows the shift tube to be pushed further out of the housing and will not affect the use of the tool on other columns.

14. Remove the shift tube assembly using Tool J-22551 (Fig. 3B4-65). Insert the hooked end of the tool into the notch in the shift tube just below the shift lever housing key. Pilot the sleeve over the threaded end of the tool and into the upper end of the shift tube. Force the shift tube out of the housing by turning the nut onto the tool. If the shift tube is not completely free when the nut is bottomed on the threads, complete the removal by hand.
 

**NOTICE:** Do not hammer or pull on the shift tube during removal. On column shift models, guide the lower shift lever through the slotted opening in the column to prevent damage to the tube or column.
15. Remove the lock plate by sliding out of the column notches, tipping the plate downward toward the housing (to compress the wave washer) and then removing as shown in Figure 3B4-66. Remove the wave washer.
16. Remove the shift lever housing.
17. Column Shift Models - Remove the shift lever spring by winding the spring up with pliers.
18. If necessary, remove the dash panel seal, mounting plate and the instrument panel seal from the column jacket.

#### Assembly of Tilt Column

When lubricating components during the following installation sequence, use any general purpose lithium soap grease.

1. Install the dash panel seal, mounting plate and the instrument panel seal on the column.
2. Column Shift Models - Press a new shift lever spring into the shift lever housing.
3. Slide the shift lever housing over the upper end of the column.
4. Place the wave washer and lock plate in position. Work the lock plate into the notches by tipping the plate toward the housing (compressing the wave washer) at the open side of the column. Lubricate the lock plate and upper end of the shift tube.
5. Carefully install the shift tube into the lower end of the column (make sure the foam seal is at lower end of the shift tube). Align the keyway in the tube with the key in the shift lever housing and complete installation of the shift tube using Tool J-22549 (Fig. 3B4-67). The shift lever housing key must bottom in the shift tube slot to be fully installed. Remove Tool J-22549 from the column. Lubricate and push foam seal in flush with column housing.

**NOTICE:** Do Not hammer or force the tube when



Fig. 3B4-57--Tilt Steering Column-G & P

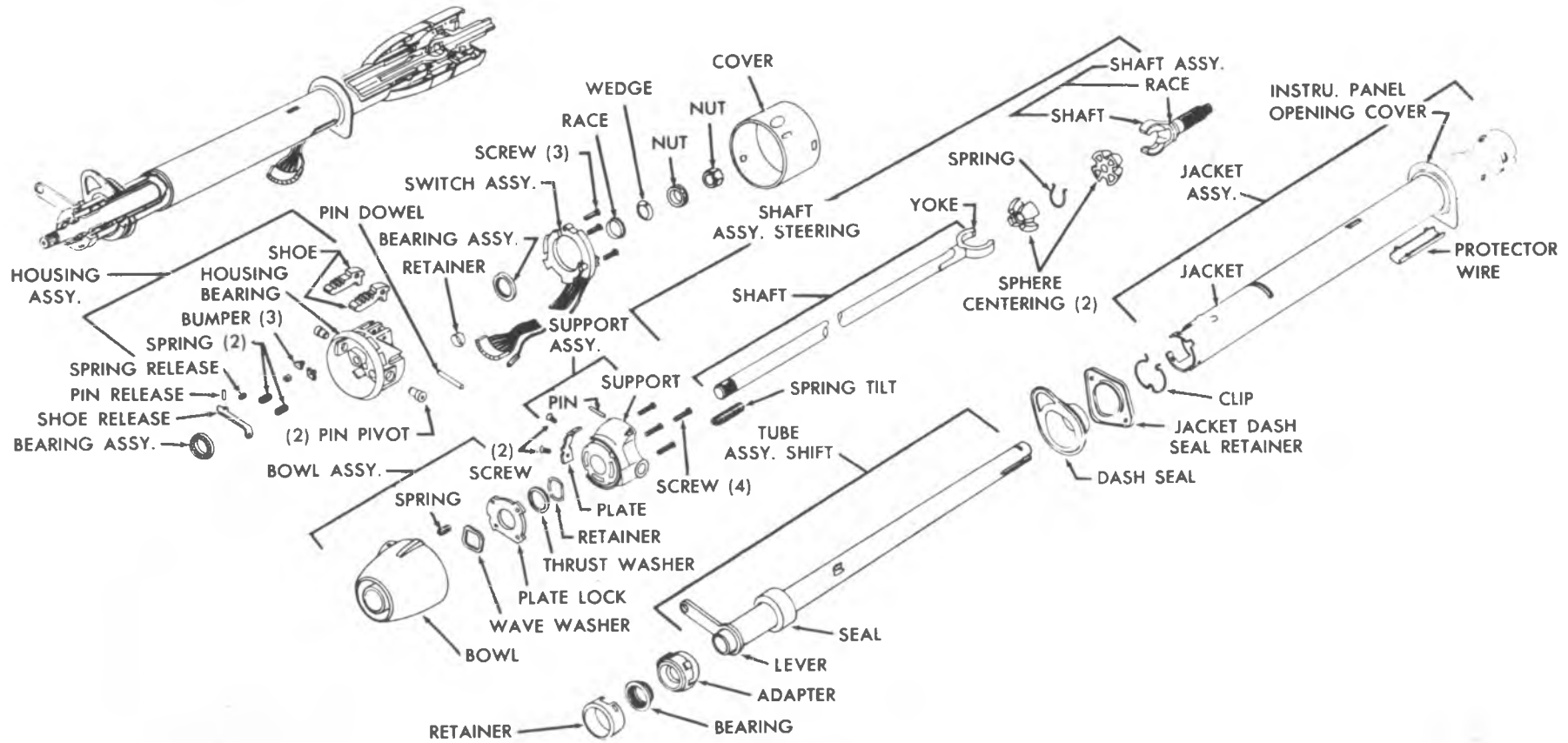

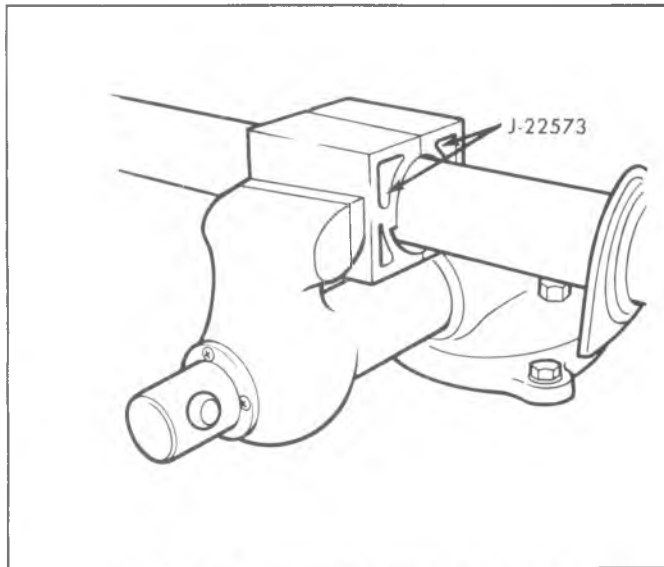

Fig. 3B4-58--Securing Column with J-22573

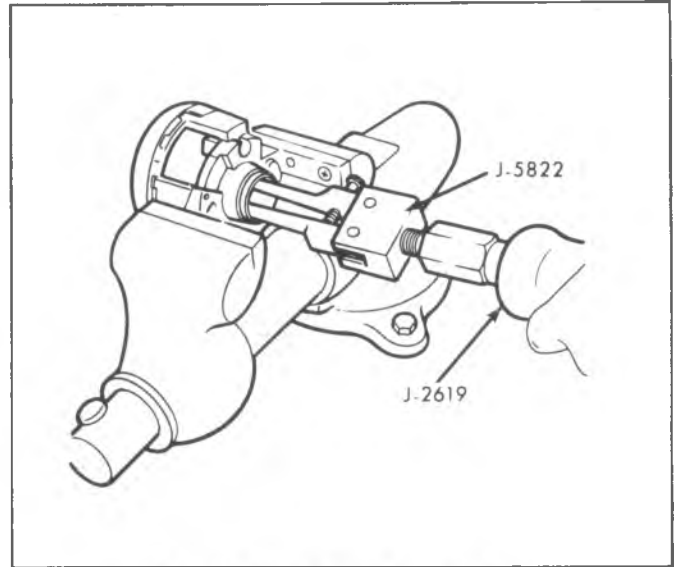

Fig. 3B4-61--Removing Bearing Race

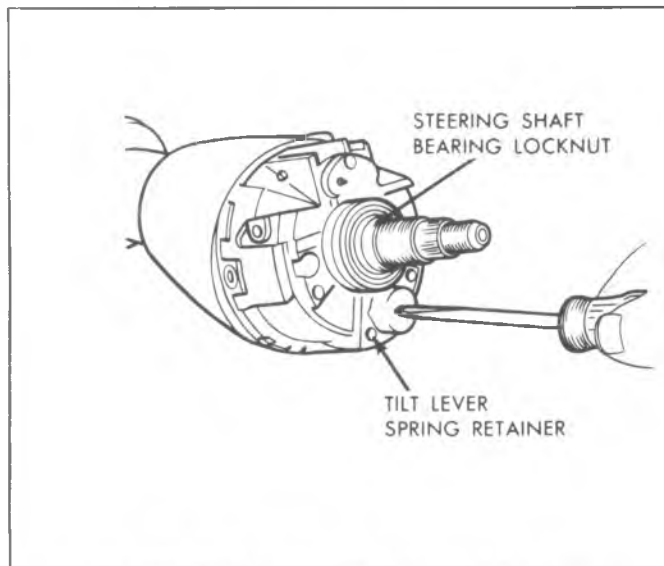

Fig. 3B4-59--Removing Tilt Spring and Retainer

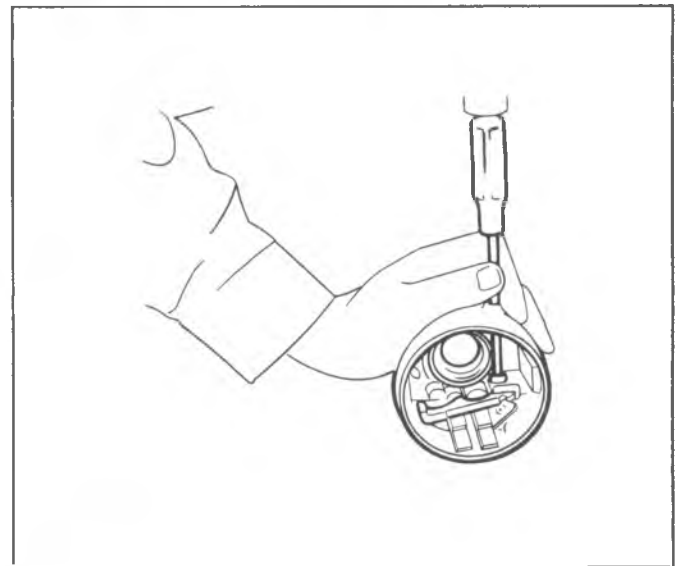

Fig. 3B4-62--Removing Release Lever Pivot Pin

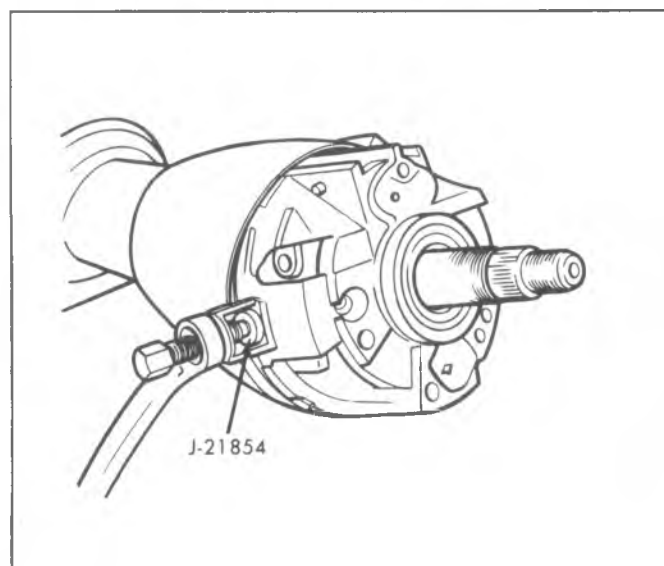

Fig. 3B4-60--Removing Bearing Housing Pivot Pin

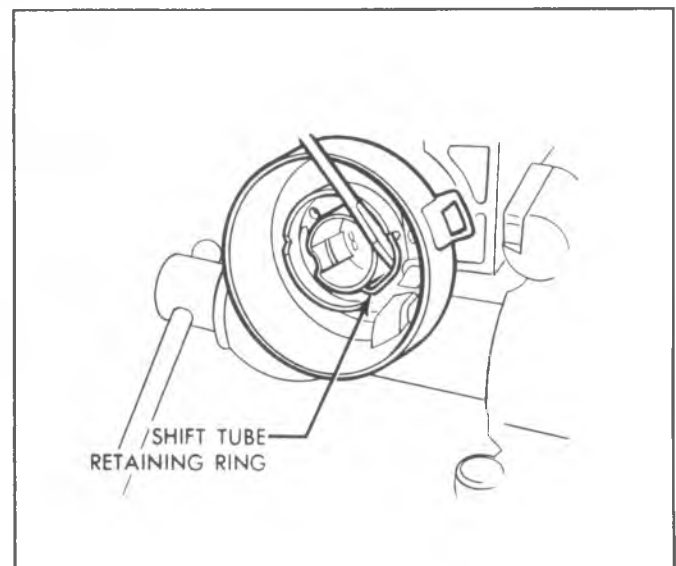

Fig. 3B4-63--Removing Shift Tube Retaining Ring

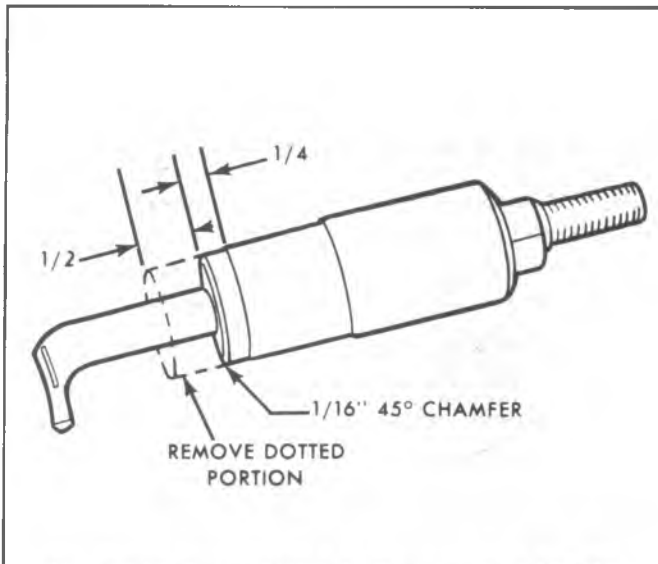

Fig. 3B4-64--Revised Shift Tube Removing Tool J-22551

The alignment pin plastic spacers must be removed before the vehicle can be driven. installing in the column, or damage could occur to the components.

6. Pull up on the shift lever housing (to compress the wave washer) and install the thrust washer and retaining ring. Be sure the ring is seated in both slots of the shift tube.
7. Lubricate the I.D. of the bearing housing support and install the support, aligning the bolt holes in the support with the bolt holes in the lock plate. Install the four support screws and torque to 45 in. lbs.
8. Assemble the steering shaft as follows:
  - a. Lubricate and assemble the centering spheres and preload spring.
  - b. Install the spheres into the upper (short) shaft and rotate 90°.

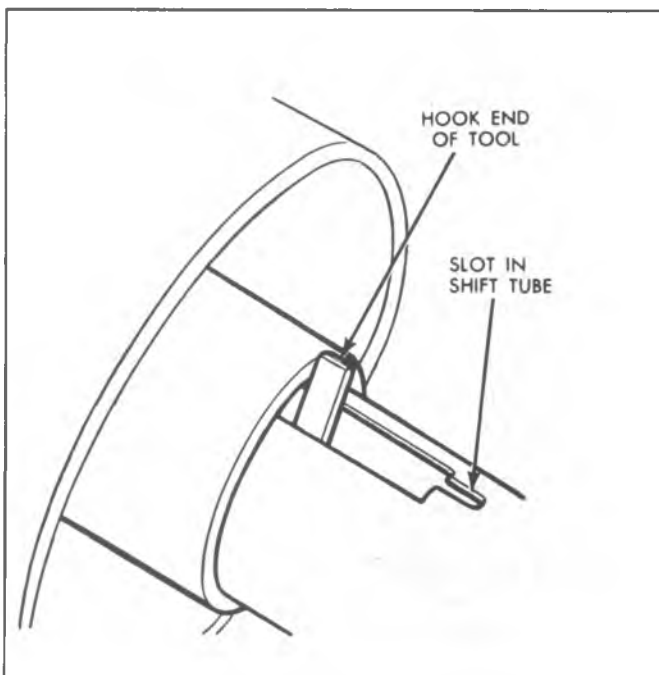

Fig. 3B4-65--Removing Shift Tube Assembly

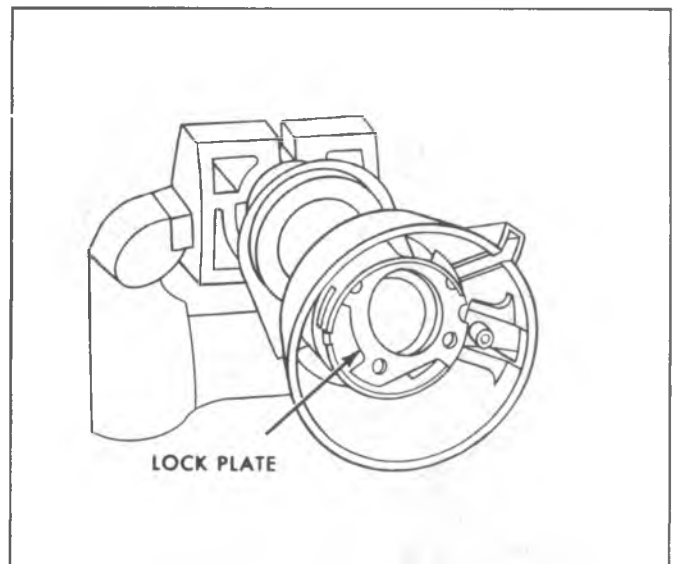

Fig. 3B4-66--Removing Lock Plate Assembly

- c. Install the lower shaft 90° to the upper shaft and over the centering spheres. Slowly straighten the shafts while compressing the preload spring.
9. Install the shaft assembly into the housing from the upper end.
10. Install the lower bearing and adapter, bearing reinforcement, wire clip, pot joint coupling and lower shaft as described under "Lower Bearing Installation".
11. Assemble the bearing housing as follows:
  - a. Press the new upper and lower bearing races into the bearing housing.
  - b. Lubricate and install the bearings into the bearing races.
  - c. Place the lock shoe springs in position in the housing. Install each shoe in place and compress the spring until a suitable size straight punch can be used to hold the shoes in position (it may be necessary to acquire assistance to install the shoes). Once the shoes are in place, drive in the shoe retaining pin.

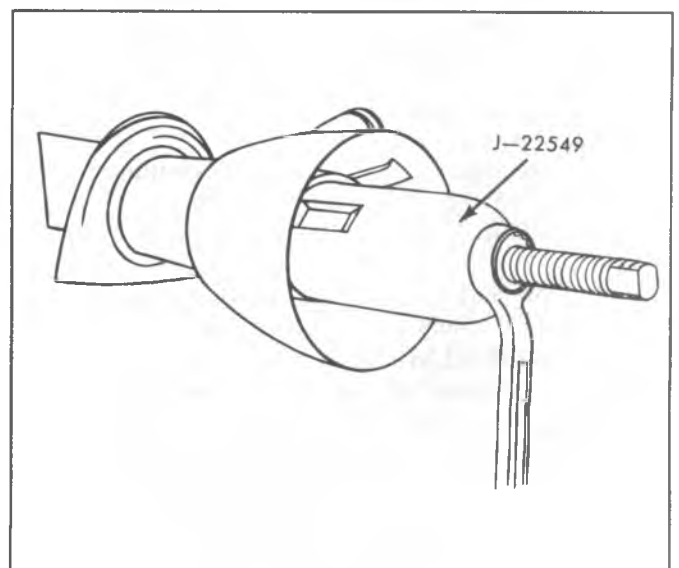
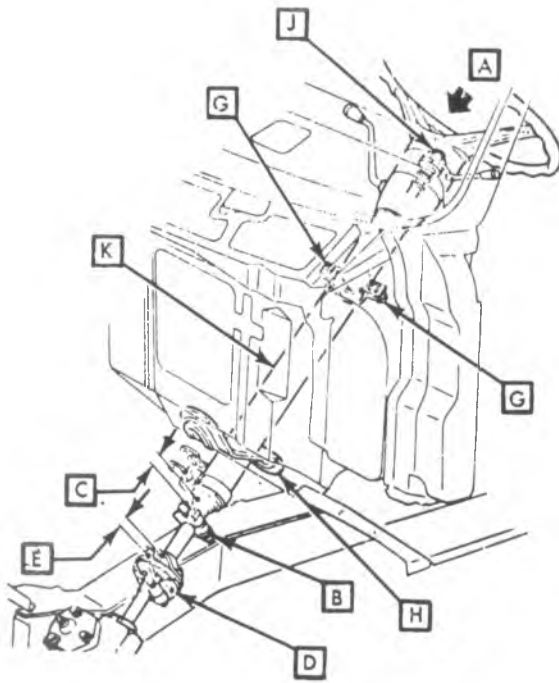

Fig. 3B4-67--Installing Shift Pin Tube



### STEERING SYSTEM MANDATORY REQUIREMENTS

1. Using a 50 lb. force applied to the steering wheel end of Shaft **A**, Lower Clamp Nut **B** must be tightened to the specified torque to give a compressed spring dimension **C** of  $.50 \pm .04$  after assembly.
2. Flexible Coupling **D** setup dimension **E** must be  $.250/.375$ . **NOTICE** This dimension must be held to prevent distortion of Flexible Coupling with resultant bind and harshness.
3. All Mast Jacket attachments **G** & **H** must be tightened to recommended torque.
4. Threaded portion of Steering Shaft **J** must be completely free of lubricant after Mast Jacket **K** assembly to maintain steering wheel clamping load and hub clearance.

Fig. 3B4-68--Mandatory Sequence For Installation Of G Series Column

- d. Install the shoe release lever and drive in the pivot pin.
- e. Install the tilt release lever.
- f. Lubricate the shoes and release lever.
12. Install the bearing housing assembly to the support. Hold the tilt release lever in the "up" position until the shoes have fully engaged the support. Lubricate and install the bearing housing pivot pins. Press the pins in flush with the housing.
13. Place the housing in the full "up" position and then install tilt spring and retainer (tapered end of spring first). Push into the housing approximately  $3/16$ " and rotate counter clockwise  $1/8$  turn.
14. Lubricate and install the upper bearing upper race, race seat and locknut. Tighten the locknut (using Socket J-22549) to remove the lash and then further tighten  $1/16$  to  $1/8$  of a turn (column must be in straight ahead position).
15. Remove the tilt release lever.
16. Install the directional signal switch as outlined under "Directional Signal Switch-Installation".
17. Column Shift Models - Install the shift lever and pivot pin.
18. Install the neutral-safety or back-up lamp switch.
19. Remove the column from the bench vise.
2. Install the plastic spacers onto the flexible coupling alignment pins.
3. From inside the vehicle, carefully insert the lower end of the column through the toe pan opening guiding the steering shaft flange onto the flexible coupling. Install and torque the glange to coupling bolts.
4. Locate the index slot in the column jacket with the protrusion on the clutch and brake pedal support.
5. Loosely install the column dash bracket and screws.
6. Push the column down until the steering shaft flange bottoms on the plastic spacers on the flexible coupling and then torque the dash bracket screws.
7. Remove the plastic spacer from the alignment pins using a wire hook. Check the flexible coupling to steering shaft flange clearance ( $.25$ " to  $.325$ " ), if not within specifications, the dash bracket screws must be loosened and the column raised or lowered as required. Retorque the bracket screws.
8. Push the toe pan seal to the toe pan, install and torque the mounting screws.
9. All Columns-Connect the directional signal switch wiring harness.  
Automatic Columns-Connect the conductor tube (for transmission indicator) to the instrument panel. See Fig. 3B4-69.
10. Install the steering wheel as outlined under "Steering Wheel Installation".
11. Connect the transmission linkage.
12. Connect the battery ground cable.

## COLUMN INSTALLATION

### Mandatory Installation Sequence G Series

**NOTICE:** See NOTICE on page 1 of this section regarding the fasteners referred to in steps 3 and 10.

1. Adjust the column lower bearing preload by applying a force on the steering wheel end of the steering shaft (A). Position the spring and clamp to maintain the dimension as detailed under "Maintenance and Adjustments."

### Mandatory Sequence P Series

**NOTICE:** See NOTICE note on page 1 of this section regarding the fasteners referred to in steps 1, 2, 3 and 10.

1. Applying 50 lbs. force on the steering wheel end of the steering shaft, adjust the lower bearing preload to allow

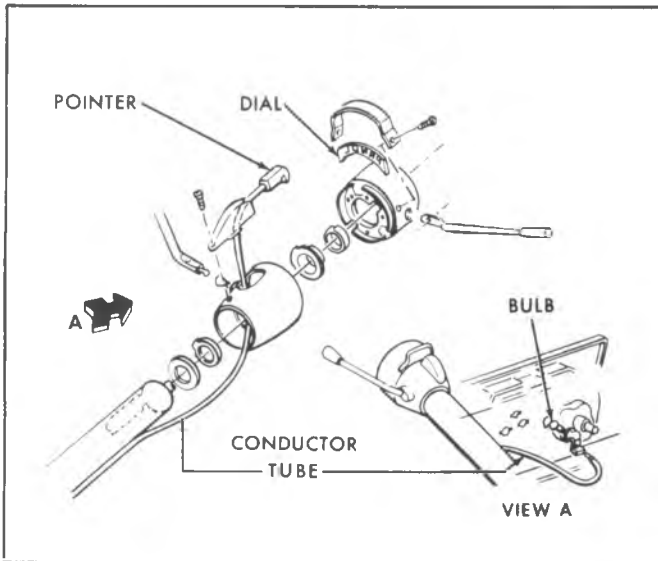

Fig. 3B4-69--Conductor Tube For Automatic Transmission Indicator

steering shaft end play as indicated in "Maintenance and Adjustments". Tighten the shaft clamp on pot joint bolt to specifications.

- From the passenger side of the dash panel, carefully insert the lower end of the steering column through the toe panel opening. Guide the steering shaft into the universal yoke, lining

up the marks made at removal. Install the yoke pinch bolt and torque to specifications. The pinch bolt must pass through the shaft undercut.

- Position and attach the lower clamp mounting bracket to the firewall. Locate the steering column protrusions against the toe pan bracket while at the same time, aligning protrusion in brake and clutch pedal support with index slot in the steering column, as shown in Figure 3B4-69. Install the column to bracket clamp and torque the clamp bolt to specifications. The toe pan bracket must not override the protrusions on the steering column.
- Position the steering column to dash panel bracket, install the attaching bolts and torque to specifications.
- If plastic spacers were used on the flexible coupling alignment pins, remove the spacers after all bolts have been properly torqued.
- Install the seal at the toe pan and then install the toe pan bracket screws; torque to specifications.
- Install the dash panel trim plate (if so equipped).
- Connect the transmission shift linkage on column shift models.
- All Columns - Connect the directional signal wiring harness.
- Standard Column with Automatic Transmission - Connect the conductor tube (for transmission indicator) at the instrument panel (Fig. 3B4-70).
- Install steering wheel as outlined under "Steering Wheel-Installation".
- Connect battery ground cable.

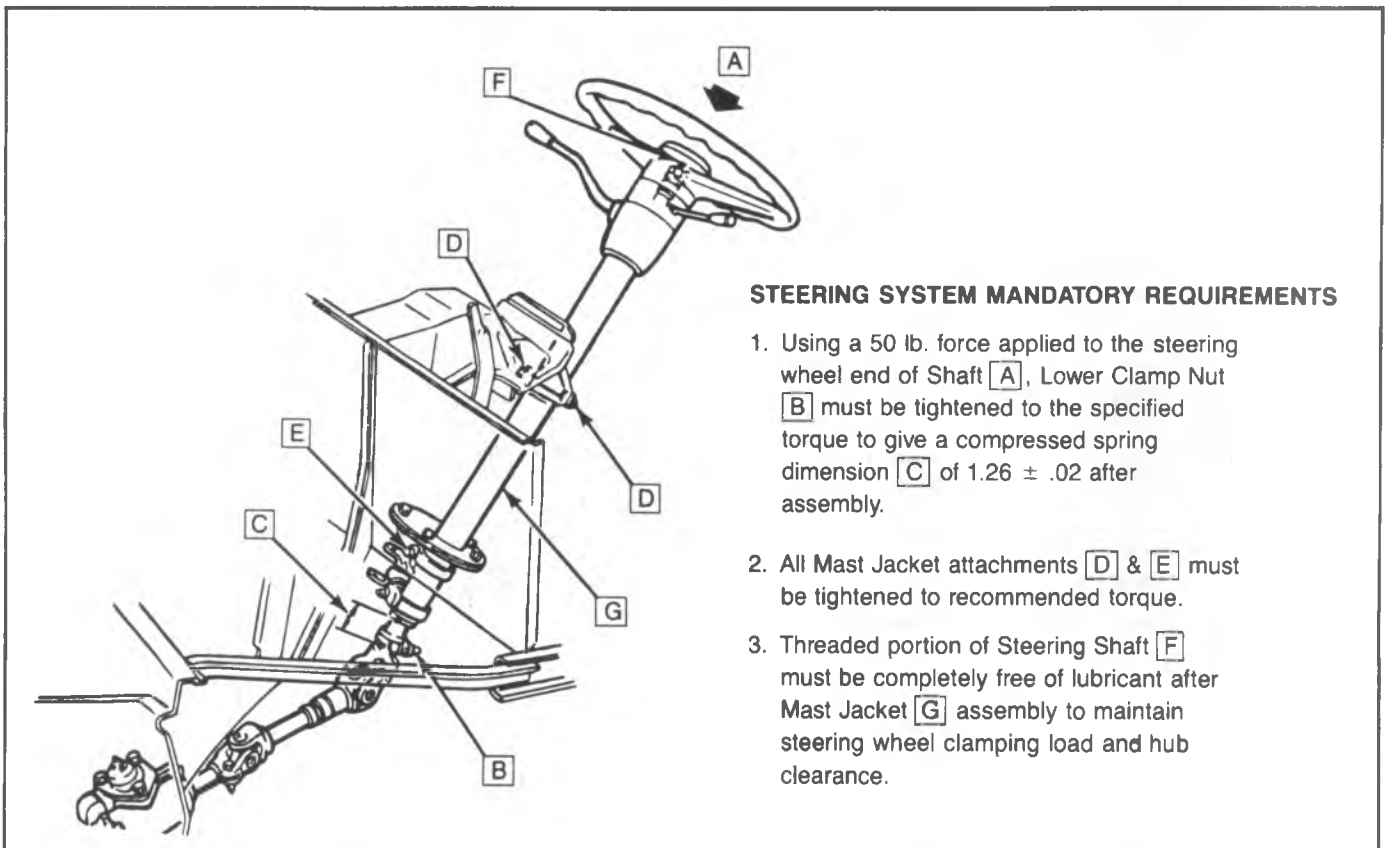

**STEERING SYSTEM MANDATORY REQUIREMENTS**

- Using a 50 lb. force applied to the steering wheel end of Shaft **A**, Lower Clamp Nut **B** must be tightened to the specified torque to give a compressed spring dimension **C** of  $1.26 \pm .02$  after assembly.
- All Mast Jacket attachments **D** & **E** must be tightened to recommended torque.
- Threaded portion of Steering Shaft **F** must be completely free of lubricant after Mast Jacket **G** assembly to maintain steering wheel clamping load and hub clearance.

Fig. 3B4-70--Mandatory Sequence For Installation of P Series Column

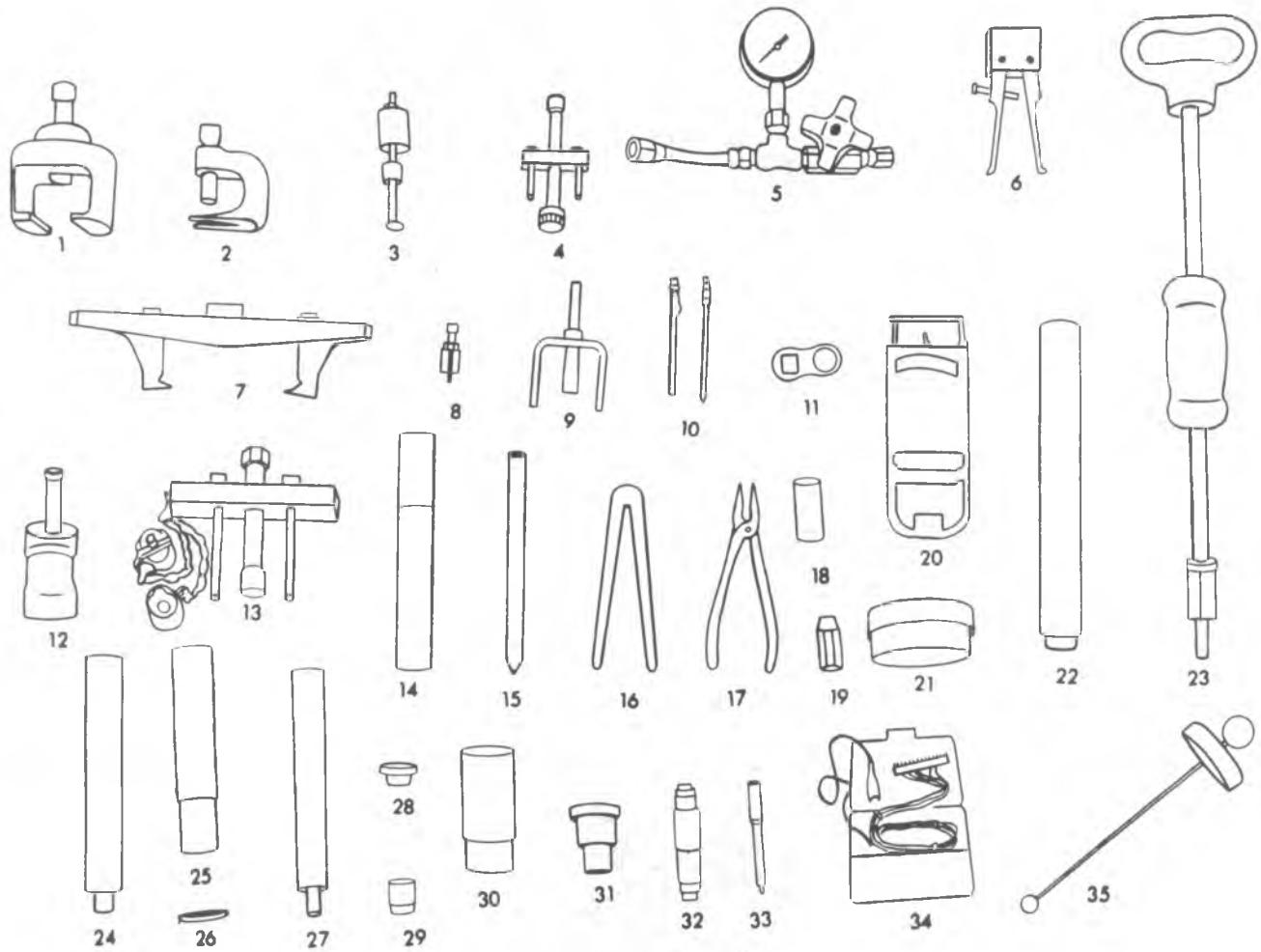

- |             |                                      |              |                                     |
|-------------|--------------------------------------|--------------|-------------------------------------|
| 1. J-6632   | Pitman Arm Puller                    | 19. J-6222   | Shaft Seal Protector                |
| 2. J-5504   | Pitman Arm Puller                    | 20. J-23600  | Belt Tension Gauge                  |
| 3. J-23073  | Shift Tube Installer                 | 21. J-8947   | Rack-Piston Seal Compressor         |
| 4. J-23072  | Shift Tube Remover                   | 22. J-5755   | Wormshaft Bearing Race Installer    |
| 5. J-5176   | Oil Pressure Gauge                   | 23. J-2619   | Slide Hammer                        |
| 6. J-5822   | Wormshaft Bearing Cup Remover        | 24. J-8092   | Handle                              |
| 7. J-8433   | Pump Pulley Remover (Cast Pulley)    | 25. J-6278   | Pitman Shaft Bearing Remover        |
| 8. J-21854  | Column Pivot Pin Remover             | 26. J-6278-2 | Pitman Shaft Bearing Installer      |
| 9. J-23653  | Lock Plate Compressor                | 27. J-7079-2 | Handle                              |
| 10. J-5421  | Thermometer                          | 28. J-8524-1 | Adjuster Plug Bearing Installer     |
| 11. J-5860  | Torque Wrench Adapter                | 29. J-8524-2 | Adjuster Plug Bearing Remover       |
| 12. J-21239 | Pump Pulley Remover (Stamper Pulley) | 30. J-6219   | Pitman Shaft Seal Installer         |
| 13. J-2927  | Steering Wheel Puller                | 31. J-22407  | Pitman Shaft Bearing Installer      |
| 14. J-1614  | Sector Shaft Bushing Remover         | 32. J-8937   | Ball Seal Remover                   |
| 15. J-7539  | Ball Retainer                        | 33. I-6217   | Connector Seat Installer            |
| 16. J-7624  | Spanner Wrench                       | 34. J-23980  | Steering Column Electrical Analyzer |
| 17. J-4245  | #23 Internal Pliers                  | 35.          | Torque Wrenches                     |
| 18. J-22670 | Pump Shaft Seal Installer            |              |                                     |

Fig. 3B-1ST--Special Tools C and K Models

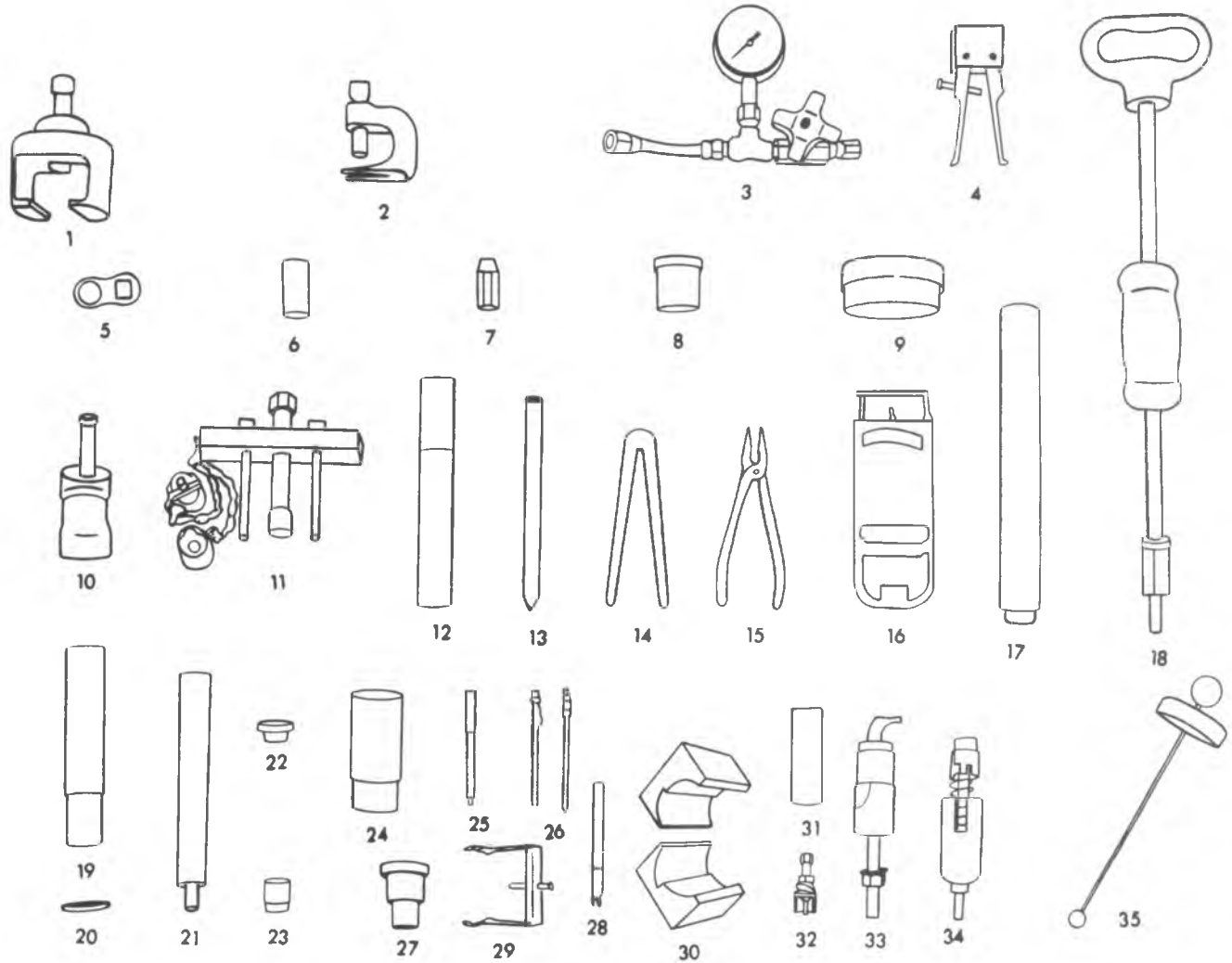

- |             |                                 |              |                                 |
|-------------|---------------------------------|--------------|---------------------------------|
| 1. J-6632   | Pitman Arm Puller               | 19. J-6278   | Pitman Shaft Bearing Remover    |
| 2. J-5504   | Pitman Arm Puller               | 20. J-6278-2 | Pitman Shaft Bearing Installer  |
| 3. J-5176   | Pressure Gauge                  | 21. J-7079-2 | Drive Handle                    |
| 4. J-5822   | Wormshaft Bearing Cup Puller    | 22. J-8524-1 | Adjuster Plug Bearing Installer |
| 5. J-5860   | Torque Wrench Adapter           | 23. J-8524-2 | Adjuster Plug Bearing Remover   |
| 6. J-22670  | Pump Shaft Seal Installer       | 24. J-6219   | Pitman Shaft Seal Installer     |
| 7. J-6222   | Shaft Seal Protector            | 25. J-6217   | Connector Seat Installer        |
| 8. J-9226   | Pitman Shaft Bushing Replacer   | 26. J-5421   | Thermometer                     |
| 9. J-7576   | Rack-Piston Seal Compressor     | 27. J-22407  | Pitman Shaft Bearing Installer  |
| 10. J-21239 | Pump Pulley Remover             | 28. J-22727  | Terminal Remover                |
| 11. J-2927  | Steering Wheel Puller           | 29. J-22708  | Turn Signal Cover Remover       |
| 12. J-1614  | Sector Shaft Bushing Remover    | 30. J-22573  | Steering Column Holding Fixture |
| 13. J-7539  | Ball Retainer                   | 31. J-22599  | Lock Nut Socket                 |
| 14. J-7624  | Spanner Wrench                  | 32. J-21854  | Pivot Pin Remover               |
| 15. J-4245  | #23 Internal Pliers             | 33. J-22551  | Shift Tube Remover              |
| 16. J-23600 | Belt Tension Gauge              | 34. J-22549  | Shift Tube Installer            |
| 17. J-5755  | Wormshaft Bearing Cup Installer | 35.          | Torque Wrenches                 |
| 18. J-2619  | Slide Hammer                    |              |                                 |

Fig. 3B-2ST--Special Tools G and P Models





## SECTION 3C

# FRONT SUSPENSION

The following notice applies to one or more steps in the assembly procedure of components in this portion of the manual as indicated at appropriate locations by the terminology "See Notice on page 1 of this section".

**NOTICE** This fastener is an important attaching part in that it could affect the performance of vital components and systems, and/or could result in major repair expense. It must be replaced with one of the same part number or with an equivalent part if replacement becomes necessary. Do not use a replacement part of lesser quality or substitute design. Torque values must be used as specified during reassembly to assure proper retention of this part.

### CONTENTS OF THIS SECTION

|                                       |       |
|---------------------------------------|-------|
| Front Suspension (C-G-P Series) ..... | 3C-2  |
| Front Suspension (K-Series) .....     | 3C-14 |

## FRONT SUSPENSION, TWO-WHEEL DRIVE

### INDEX

|                                   |      |                               |       |
|-----------------------------------|------|-------------------------------|-------|
| General Description .....         | 3C-2 | Upper Control Arm Shaft ..... | 3C-7  |
| Maintenance and Adjustments ..... | 3C-3 | Lower Control Arm Shaft ..... | 3C-7  |
| Component Parts Replacement ..... | 3C-5 | Upper Control Arm .....       | 3C-8  |
| Wheel Hubs, Bearings .....        | 3C-5 | Lower Control Arm .....       | 3C-9  |
| Shock Absorber .....              | 3C-6 | Ball Joint .....              | 3C-11 |
| Stabilizer .....                  | 3C-6 | Steering Knuckle .....        | 3C-12 |
| Coil Spring .....                 | 3C-6 | Suspension Unit .....         | 3C-13 |
|                                   |      | Specifications .....          | 3C-30 |
|                                   |      | Special Tools .....           | 3C-31 |

## GENERAL DESCRIPTION

### C-G-P Series

The C-G-P Series trucks incorporate an independent coil spring front suspension system, as shown in Figures 3C-1 and 3C-2. The control arms are of unequal length (S.L.A. Type).

This suspension system consists of upper and lower control arms pivoting on steel threaded or rubber bushings on upper and lower control arm shafts. The lower control arms are attached to the crossmember. The upper control arms are attached to a frame bracket. These control arms are connected to the steering knuckle through pivoting ball joints.

A coil spring is located between the lower control arm and a formed seat in the suspension crossmember, thus the lower control arm is the load carrying member. Double acting shock absorbers are also attached to the lower control arms and connect with the frame to the rear on the upper end. The front wheel bearings are tapered roller type and are used on all models.

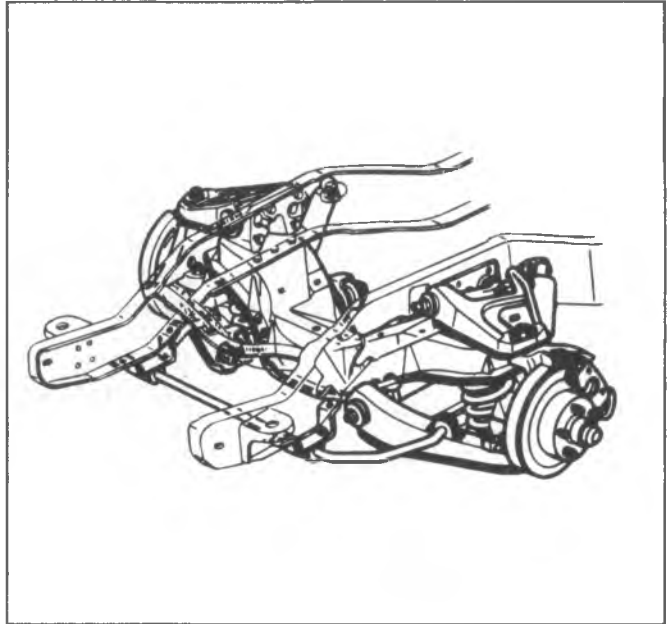

Fig. 3C-1--Front Suspension, C-P Series

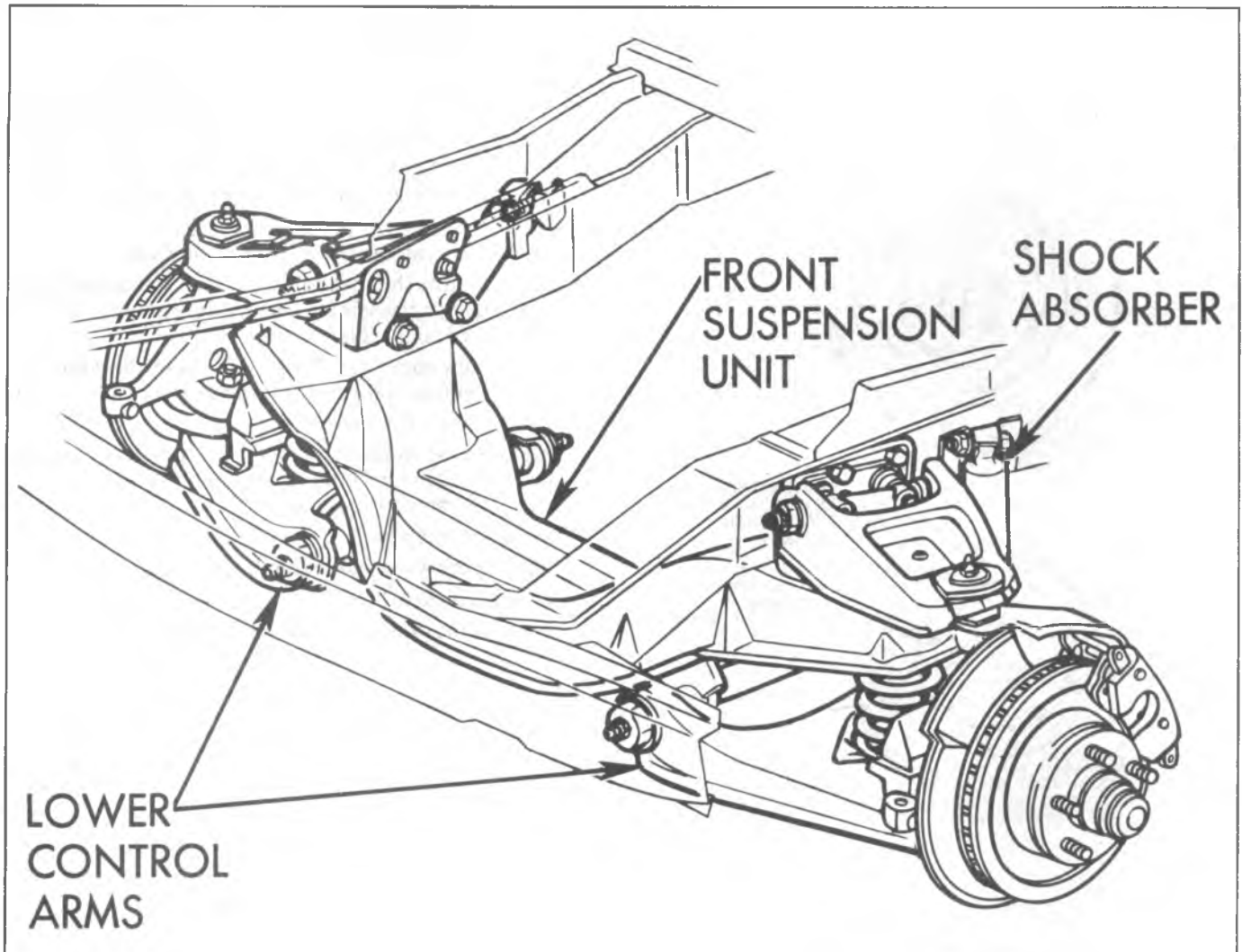

Fig. 3C-2--Front Suspension - G-Typical

## MAINTENANCE AND ADJUSTMENTS

**NOTICE:** See NOTICE on page 1 of this section regarding the fasteners referred to in the maintenance and adjustment procedures below.

### WHEEL BEARINGS-CHECK ADJUSTMENT

**NOTICE:** Tapered roller bearings are used on all series vehicles and they have a slightly loose feel when properly adjusted. A design feature of front wheel taper roller bearings is that they must NEVER be pre-loaded. Damage can result by the steady thrust on roller ends which comes from preloading.

1. Raise vehicle and support at front lower control arm.

2. Spin wheel to check for unusual noise or roughness.

3. If bearings are noisy, tight, or excessively loose, they should be cleaned, inspected and relubricated prior to adjustment. If it is necessary to inspect bearings, see "Wheel Hubs, Bearings" under "Component Parts Replacement."

To check for tight or loose bearings, grip the tire at the top and bottom and move the wheel assembly in and out on the spindle. Measure movement of hub assembly. If movement is less than .025 mm (.001") or greater than .127 mm (.005"), adjust bearings per adjustment procedure.

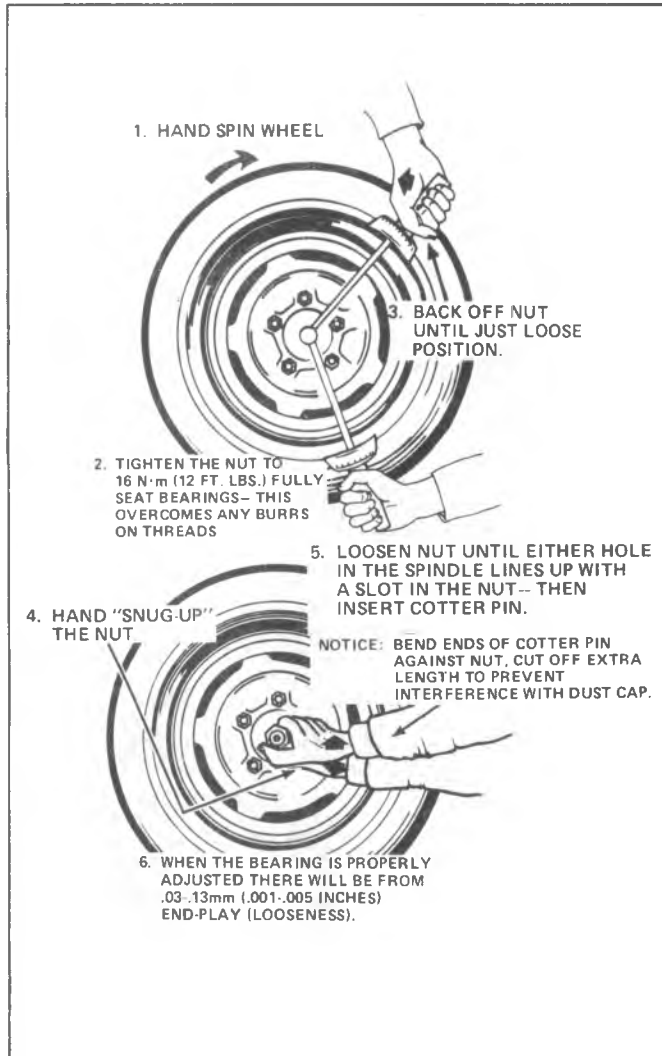

Fig. 3C-3--Wheel Bearing Adjustment

**ADJUSTMENT OF WHEEL BEARINGS (FIG. 3C-3)**

1. Remove hub cap or wheel disc from wheel.
2. Remove dust cap from hub.
3. Remove cotter pin from spindle and spindle nut.
4. Tighten the spindle nut to 16 N·m (12 ft. lbs.) while turning the wheel assembly forward by hand to fully seat the bearings. This will remove any grease or burrs which could cause excessive wheel bearing play later. See Fig. 3C-3.
5. Back off the nut to the "just loose" position.
6. Hand tighten the spindle nut. Loosen spindle nut until either hole in the spindle lines up with a slot in the nut. (Not more than 1/2 flat).
7. Install new cotter pin. Bend the ends of the cotter pin against nut, cut off extra length to ensure ends will not interfere with the dust cap.
8. Measure the looseness in the hub assembly. There will be from .025 mm (.001) to .127 mm (.005 inches) end play when properly adjusted.
9. Install dust cap on hub.
10. Replace the wheel cover or hub cap.
11. Lower vehicle to floor.
12. Perform the same operation for each front wheel.

## COMPONENT PARTS REPLACEMENT

### WHEEL HUBS, BEARINGS (Fig. 3C-14)

#### Removal C, G and P Series

1. Raise vehicle on hoist and remove wheel and tire assembly. Remove dust cap from end of hub and withdraw cotter pin.
2. Remove the brake caliper and hang by wire to the suspension. Do not allow the caliper assembly to hang by the brake flex line.
3. Remove hub and disc assembly.
4. Remove outer bearing from hub. The inner bearing will remain in the hub and may be removed by prying out the inner grease seal.
5. Wash all parts in cleaning solvent.

#### Inspection

1. Check all bearings for cracked bearing cages, worn or pitted rollers.
2. Check bearing races for cracks or scoring, check brake discs for out-of-round or scored conditions and check bearing outer races for looseness in hubs.

#### Repairs

##### Replacement of Bearing Cups

If necessary to replace an outer race, drive out old race from the hub with a brass drift inserted behind race in notches in hub. Install new race by driving it into hub with the proper race installer J-8457, J-8458, J-8849 or J-9276-2. Remove and install the inner race in the same manner.

**NOTICE:** Use care when installing new race to start it squarely into hub, to avoid distortion and possible cracking.

##### Wheel Stud Replacement (Fig. 3C-14)

Use a piece of water pipe or other similar tool to support the hub while pressing a wheel stud either in or out.

#### Installation

**NOTICE:** See NOTICE on page 1 of this section regarding the fasteners referred to in steps 8 and 9.

1. Clean off any grease in the hub and spindle and thoroughly clean out any grease in the bearings. Use

cleaning solvent. Use a small brush with no loose bristles to clean out all old grease. Do not spin the bearing with compressed air while drying it or the bearing may be damaged.

2. Use a GM approved high temperature front wheel bearing grease or equivalent. Do not mix greases as mixing may change the grease properties and result in poor performance.
3. Apply a thin film of grease to the spindle at the outer bearing seat and at the inner bearing seat, shoulder, and seal seat.
4. Put a small quantity of grease inboard of each bearing cup in the hub. This can be applied with your finger forming a dam to provide extra grease availability to the bearing and to keep thinned grease from flowing out of the bearing.
5. Fill the bearing cone and roller assemblies 100% fill of grease. A method for doing this is with a cone type grease machine that forces grease into the bearing. If a cone greaser is not available, the bearings can be packed by hand. If hand packing is used, it is extremely important to work the grease thoroughly into the bearings between the rollers, cone, and the cage. Failure to do this could result in premature bearing failure.
6. Place the inner bearing cone and roller assembly in the hub. Then using your finger, put an additional quantity of grease outboard of the bearing.
7. Install a new grease seal using a flat plate until the seal is flush with the hub. Lubricate the seal lip with a thin layer of grease.
8. Carefully install the hub and rotor assembly. Place the outer bearing cone and roller assembly in the outer bearing cup. Install the washer and nut and initially tighten the nut to 12 ft. lbs. while turning the wheel assembly forward by hand. Put an additional quantity of grease outboard the bearing. This provides extra grease availability to the bearing.
9. Final wheel bearing adjustment should be performed as previously outlined.

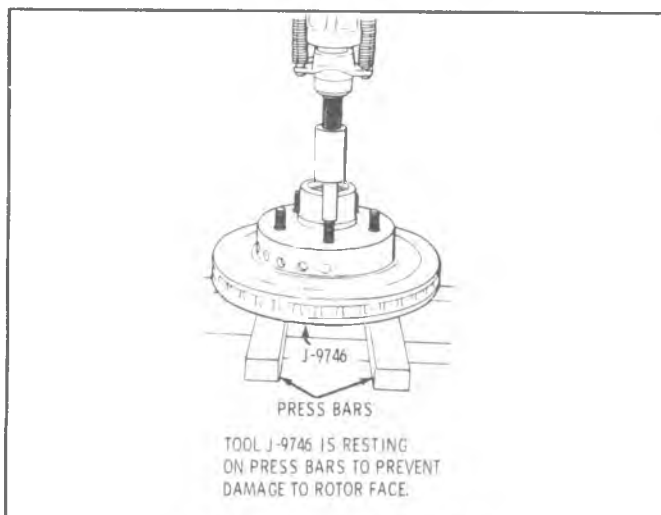

Fig. 3C-14--Pressing Hub Bolt

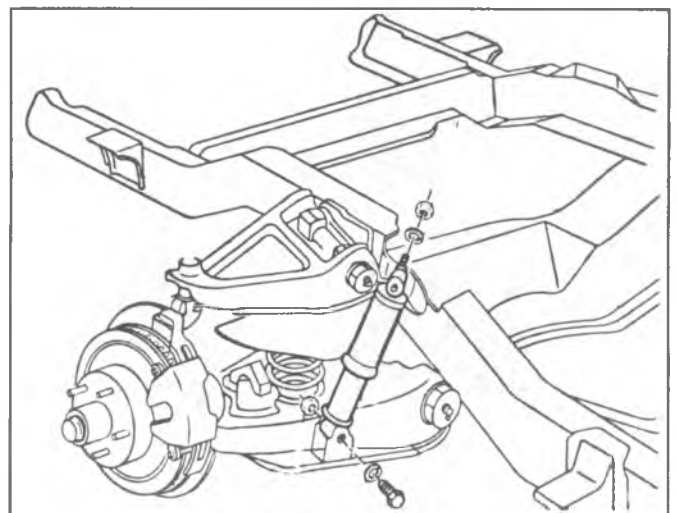

Fig. 3C-15--Shock Absorber Attachments

## SHOCK ABSORBER

### Removal (Fig. 3C-15)

1. Raise vehicle on hoist.
2. Remove nuts and eye bolts securing upper and lower shock absorber eyes.
3. Withdraw shock absorber and inspect rubber eye bushings. If defective, replace shock absorber assembly.

### Installation

Place shock absorber into position over mounting bolts or into mounting brackets. Install eye bolts and nuts and torque as shown in Specifications Section. Lower vehicle to floor.

## STABILIZER BAR

### Removal (Fig. 3C-16)

1. Raise vehicle on hoist and remove nuts and bolts attaching stabilizer brackets and bushings at frame location.
2. Remove brackets and bushings at lower control arms and remove stabilizer from vehicle.

### Inspection

Inspect rubber bushings for excessive wear or aging—replace where necessary. Use rubber lubricant when installing bushings over stabilizer bar.

### Installation

**NOTICE:** See NOTICE on page 1 of this section regarding the fasteners referred to in step 2.

Slit in bar to frame bushings should be facing forward.

1. Place stabilizer in position on frame and install frame brackets over bushings. Install nuts and bolts loosely.
2. Install brackets over bushings at lower control arm location. Be sure brackets are positioned properly over bushings. Torque all nuts and bolts to specifications.
3. Lower vehicle to floor.

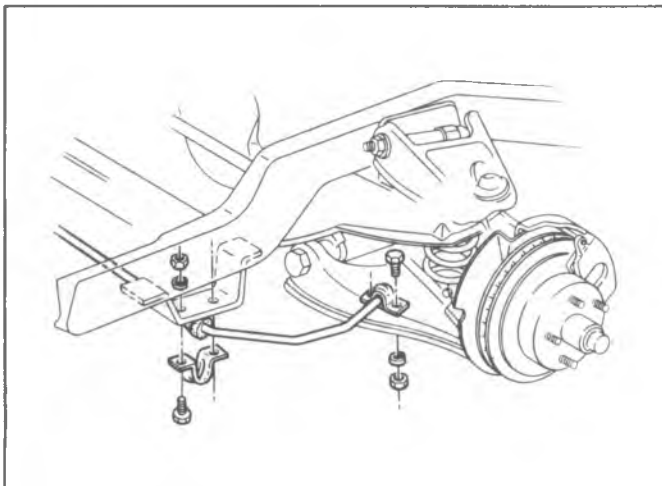

Fig. 3C-16—Stabilizer Bar - C, P and G Typical

## COIL SPRING

### Removal (Fig. 3C-17)

1. Place vehicle on hoist and place jack stands under frame, allowing control arms to hang free.
2. Disconnect shock absorber at lower end and move aside. Disconnect the stabilizer bar attachments to the lower control arm.
3. Bolt Tool J-23028 to a suitable jack.
4. Place tool under cross-shaft so that the cross-shaft seats in the grooves of the tool. As a safety precaution install and secure a chain through the spring and lower control arm.
5. Raise the jack to remove tension on the lower control arm cross-shaft and remove the two "U" bolts securing the cross-shaft to crossmember. The crossshaft and lower control arm keeps the coil spring compressed. Use care when lowering.
6. Lower control arm by slowly releasing the jack until spring can be removed. Be sure all compression is relieved from spring.
7. Remove spring.

### Installation

**NOTICE:** See NOTICE on page 1 of this section regarding the fasteners referred to steps 3 and 4.

1. Properly position spring on the control arm, and lift control arm using jack and tool J-23028. Some models are equipped with air cylinders in the coil springs. These cylinders should be checked for leaks and damage at this time. Air pressure in these cylinders should be 40 PSI  $\pm$  10.
2. Position control arm cross-shaft to crossmember and install "U" bolts and attaching nuts. Make certain front indexing hole in cross-shaft is lined up with crossmember attaching saddle stud.
3. Torque nut to specifications.
4. Install shock absorber to lower control arm and install stabilizer bar.
5. Remove tool J-23028 and safety chain.
6. Lower vehicle to floor.

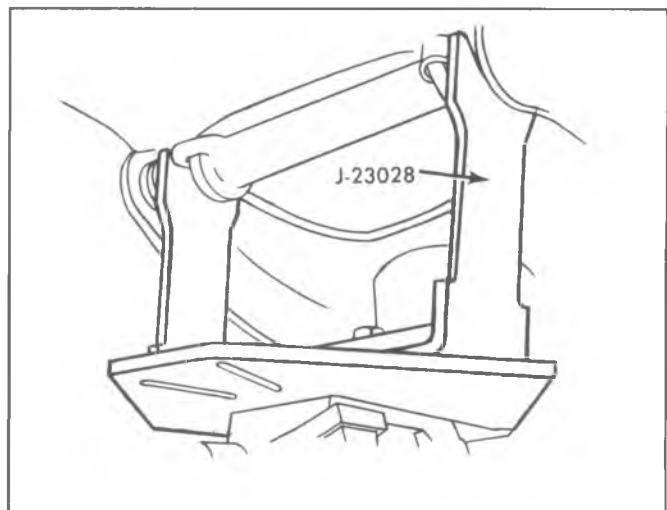

Fig. 3C-17—Removing Coil Spring with Tool J-23028

## UPPER CONTROL ARM INNER PIVOT SHAFT AND/OR BUSHING REPLACEMENT

### C20-30, G30 and P20-30 (Steel Bushings)

#### Pivot Shaft Removal

1. Raise vehicle and remove tire and wheel assembly.
2. Support the lower control arm with a floor jack. Position jack under the ball joint assembly or as near as possible and still have good support.
3. Loosen the upper control arm shaft end nuts before loosening the shaft to frame attaching nuts.
4. Loosen the shaft to frame nuts and remove the caster and camber shims. Tape the shims together as they are removed and mark for position.
5. Remove the pivot shaft to frame nuts but do not allow the arm to swing too far away from the frame.

Use a safety chain to retain the arm in a close relationship to the frame. See Fig. 3C-18.

6. Remove the shaft end nuts and remove shaft from arm.

#### Bushing Replacement (Steel Bushings)

1. Remove grease fittings from bushing outer ends and unscrew bushings from control arm and shaft.
2. Slide new seal on each end of shaft and insert shaft into control arm.
3. Start new bushings on shaft and into control arm. Adjust shaft until it is centered in control arm, then turn bushings in and torque to specifications. Figure 3C-19 shows correct final positioning of shaft. Check shaft for free rotation and install grease fittings.

#### Installation

**NOTICE:** See NOTICE on page 1 of this section regarding the fasteners referred to in steps 3, 5 and 6.

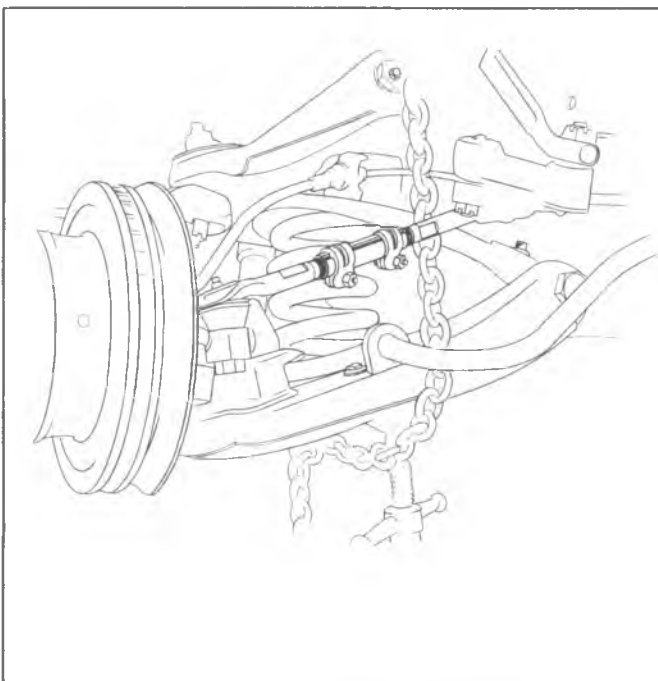

Fig. 3C-18--Removing Inner Pivot Shaft

When installing the upper control arm be sure to properly position the special aligning washers to the pivot shaft with convex and concave sides together.

1. Install the shaft to the control arm and install end nuts. Do not torque nuts at this time.
2. Position cross shaft to frame bolts and start cross shaft nuts.
3. Torque the shaft end nuts. See Fig. 3C-19 for proper spacing. The shaft should rotate by hand after the nuts are torqued.
4. Install caster and camber shim in their appropriate places.
5. Torque the cross-shaft to frame nuts.
6. Remove the safety chain and install the tire.
7. Lower vehicle to the floor.

## LOWER CONTROL ARM INNER PIVOT SHAFT AND/OR BUSHING REPLACEMENT

### C20-30, G30, P20-30 (Steel Bushings)

#### Lower-Removal (Fig. 3C-18)

1. Raise vehicle and support the frame so that control arms hang free.
2. Position an adjustable floor jack under the control arm inboard of spring and into depression in lower arm.
3. Install a chain over upper arm (Fig. 3C-18). Inboard of stabilizer and outboard of shock absorber as a safety measure.
4. Disconnect shock absorber at lower control arm.
5. Loosen shaft end nuts.
6. Remove "U" bolts.
7. Lower jack just enough to get at shaft.
8. Remove shaft end nuts and remove shaft.

#### Bushing Replacement (Steel Bushings)

1. Remove grease fittings from ends of bushings and unscrew bushings from shaft and control arm. Remove shaft and seals.

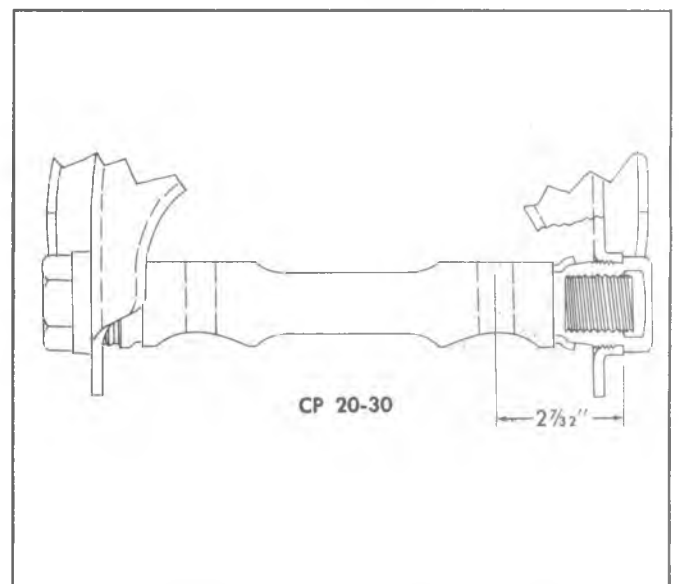

Fig. 3C-19--Positioning U.C.A. Shaft (Steel Bushings)

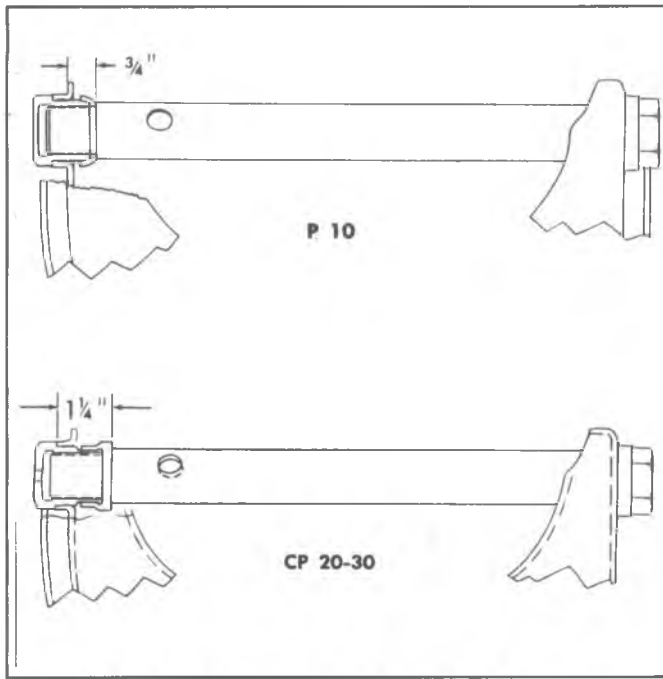

Fig. 3C-20--Positioning L.C.A. Shaft (Steel Bushings)

2. Slide new seal on each end of shaft and insert shaft into control arm.
3. Start new bushings on shaft and into control arm. Adjust shaft until it is centered in control arm, then turn bushings in and torque to specifications. Check shaft for free rotation. Figure 3C-20 shows correct final positioning of shaft.

**Installation**

**NOTICE:** See NOTICE on page 1 of this section regarding the fasteners referred to in steps 4 and 5.

1. Install shaft to control arm and install end nuts. Do not torque nuts at this time.
2. Raise jack and position shaft into crossmember saddle. Be sure to index hole in shaft to mate with bolt head in saddle.

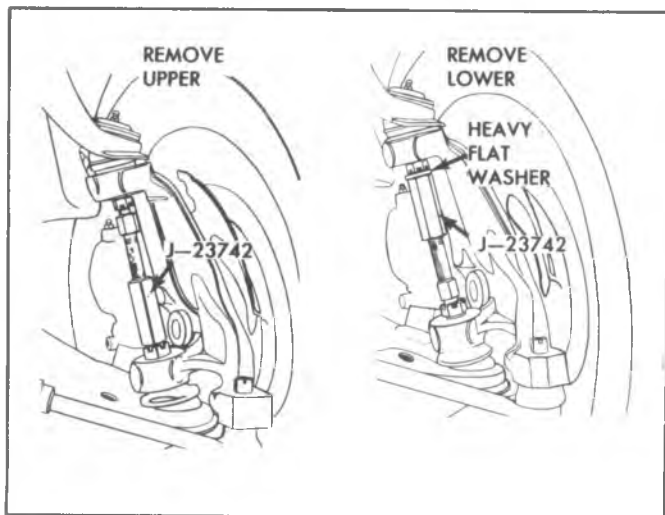

Fig. 3C-21--Disconnecting Ball Joints from Knuckle

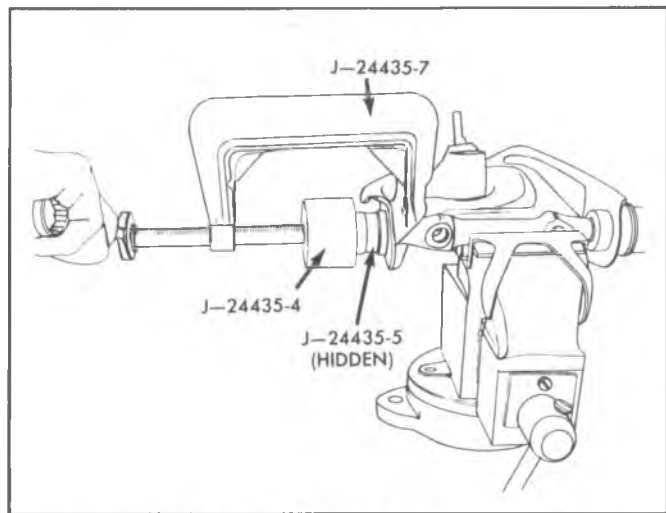

Fig. 3C-22--U.C.A. Rubber Bushing Removal

3. Install "U" bolts. Do not torque nuts at this time.
4. Torque cross-shaft end nuts. The shaft should rotate by hand after the nuts are torqued.
5. Torque "U" bolt nuts.
6. Remove safety chain.
7. Lower vehicle to floor.

**UPPER CONTROL ARM ASSEMBLY**

**All Removal**

1. Raise vehicle on hoist, remove wheel and tire assembly and support lower control arm assembly with adjustable jackstand.
2. It is necessary to remove the brake caliper assembly and wire it to the frame to gain clearance for tool J-23742. See section 5 for proper procedure.
3. Remove cotter pin from upper control arm ball stud and loosen stud nut one turn.
4. Loosen upper control arm ball stud in steering knuckle, using Tool J-23742 position as shown in Figure 3C-21. Remove the nut from the ball stud and raise upper arm to clear steering knuckle.

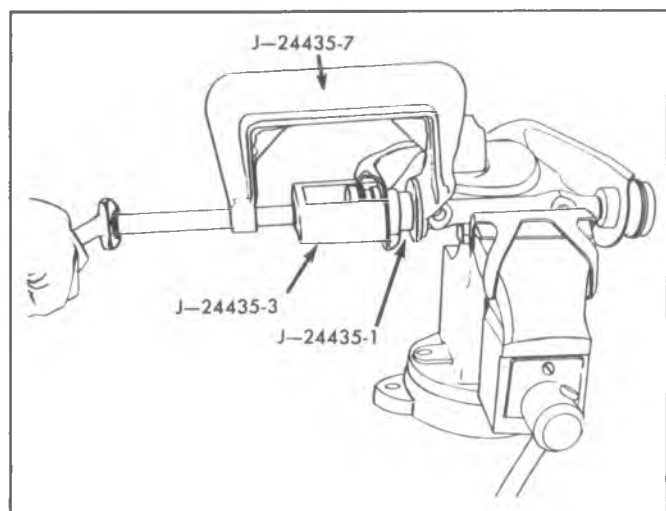

Fig. 3C-23--U.C.A. Rubber Bushing Installation



- Remove nuts securing control arm shaft to frame. Withdraw control arm assembly. Tape shims together and tag for proper relocation when control arm is reinstalled.

### Upper Control Arm Inner Pivot Shaft and/or Bushing Replacement

#### C10, G10-20, P10 (Rubber Bushings)

##### Removal (Fig. 3C-22)

- Remove the upper control arm using the preceding procedure and mount the control arm in a vise.
- Install remover J-24435-1, receiver J-24435-3 and "C" clamps J-24435-7 as shown in Figure 3C-22.
- Tighten the clamp to draw out the old bushing. Discard old bushing.
- The pivot shaft may now be removed from the control arm assembly.
- Reposition the control arm in the vise and repeat the removal procedure on the remaining bushing.

##### Bushing Installation

- Again using "C" clamp J-24435-7 and installers J-24435-4 (outer) and J-24435-5 (inner) tighten clamp to install bushing onto control arm.
- Install pivot shaft into inside diameter of first installed bushing.
- Install remaining bushing as shown in Figure 3C-23 and described in step 1.
- Remove tools and install control arm on vehicle following procedure described below. Torque all fasteners to proper specifications.

##### Upper Control Arm Installation

**NOTICE:** See NOTICE on page 1 of this section regarding the fasteners referred to in steps 1, 2 and 3.

When installing the upper control arm be sure to position the special aligning washers to the pivot shaft with concave and convex sides together.

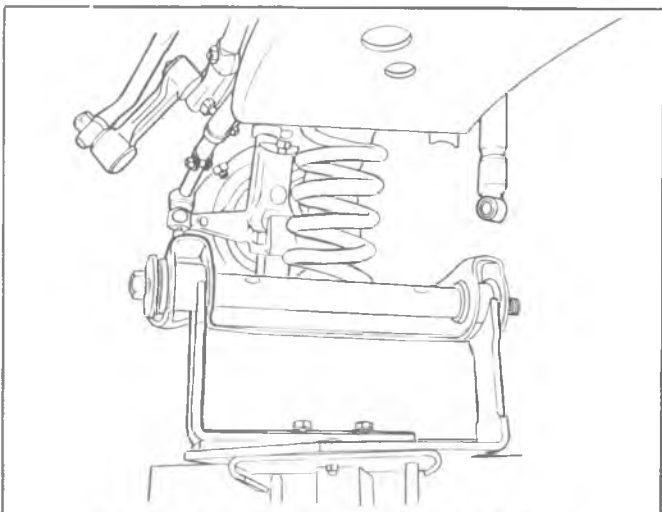

Fig. 3C-24--Lowering Control Arm for Bushing Replacement

- Place control arm in position on bracket and install nuts. Before tightening nuts, insert caster and camber shims in the same order as when removed. Torque the nuts to specifications.

A normal shim pack will leave at least two (2) threads of the bolt exposed beyond the nut. If two (2) threads cannot be obtained: Check for damaged control arms and related parts. Difference between front and rear shim packs must not exceed 7.62 mm (.30 inches). Front shim pack must be at least 6.09 mm (.24 inches). Always tighten the thinner shim packs' nut first for improved shaft to frame clamping force and torque retention.

- Insert ball joint stud into steering knuckle and install nut. Torque stud nut to specifications and install cotter pin.
- Install brake caliper assembly if removed (see section 5).
- Remove adjustable support from under lower control arm. Install wheel and tire assembly.
- Lower the vehicle to the floor.

### LOWER CONTROL ARM ASSEMBLY

##### Removal

- Raise vehicle on hoist and remove spring as outlined under spring removal. Support the inboard end of the control arm after spring removal.
- Remove cotter pin from lower ball stud and loosen stud nut one turn.
- Install Ball Stud Remover J-23742, position large cup end of the tool over the upper ball stud nut and piloting the threaded end of tool on end of the lower ball stud. Extend bolt from Tool J-23742 to loosen lower ball stud in steering knuckle. When stud is loosened, remove tool and nut from lower stud.

It is necessary to remove the brake caliper assembly and wire it to the frame to gain clearance for tool J-23742. See section 5 for proper procedure.

- Remove the lower control arm.

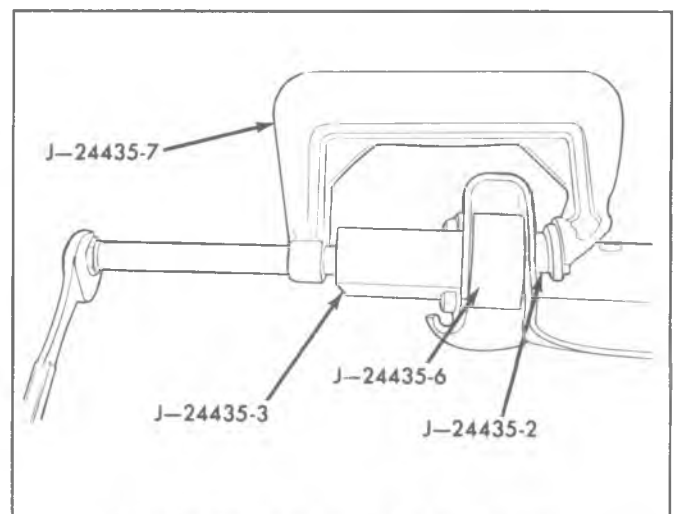

Fig. 3C-25--L.C.A. Rubber Bushing Removal

## Lower Control Arm Inner Pivot Shaft and/or Bushing Replacement-On Vehicle

### C10 (Rubber Bushings)

#### Removal (Figs. 3C-24, 3C-25)

If just bushings or pivot shaft are to be replaced the lower control arm does not have to be removed from the vehicle.

1. Raise vehicle on hoist and support the frame so that the control arms hang free.
2. Position an adjustable floor jack under the lower control arm inboard of spring and into depression of control arm.
3. Install a chain over the upper arm inboard of the stabilizer and outboard of shock absorber as a safety measure.
4. Disconnect shock and stabilizer bar attachments at lower control arm.
5. Loosen shaft end nuts.
6. Remove "U" bolts that retain the inboard end of the lower control arm.
7. Lower jack SLOWLY to release spring compression (Fig. 3C-24) and gain clearance to remove bushings. Be sure all compression is released from coil springs.
8. Remove the stakes on the front bushing using tool J-22717 or equivalent tool.
9. Bushings may now be replaced. Install "C" clamps J-24435-7 and receiver J-24435-3 with remover J-24435-2 and spacer J-24435-6 as shown in Figure 3C-25.
10. Tighten the "C" clamp to remove the bushing.
11. Remove tools and discard old bushing.
12. Pivot shaft may now be removed if necessary.
13. Remove second bushing (leave pivot shaft in to pilot tool) by the same method as in steps 8-12.

#### Bushing Installation (Fig. 3C-26)

**NOTICE:** See NOTICE on page 1 of this section regarding the fasteners referred to in step 5.

1. Install new bushings as shown in Figure 3C-26 using spacer J-24435-6, installer J-24435-4 and "C" clamp J-24435-7.
2. Turn clamp in until bushing seats firmly.

**NOTICE:** Be sure spacer J-24435-6 is in position as shown in Figure 3C-26 to avoid collapsing control arm during assembly.

3. Install one bushing then insert the pivot shaft and install second bushing.
4. Stake front bushing at least in two places when installed.
5. Install the lower control arm to the vehicle as described under "Lower Control Arm - Installation", being sure to torque all fasteners to the proper specification.

## Lower Control Arm Inner Pivot Shaft And Bushing Replacement-G10-G20 Models

### Removal

1. Remove lower control arm as previously outlined.

2. Remove pivot shaft nuts.
3. Place control arm in an arbor press, press front end of pivot shaft to remove rear bushing, and pivot shaft assembly.
4. Remove the stakes on the front bushing using Tool J-22717 or equivalent tool.
5. Install "C" clamp J-24435-7 and receiver J-24435-3 with remover J-24435-2 and spacer J-24435-6 as shown in Figure 3C-25.
6. Tighten "C" clamp to remove the bushing.

### Installation

**NOTICE:** See NOTICE on page 1 of this section regarding the fasteners referred to in step 5.

1. Install new bushings as shown in Figure 3C-26 using spacer J-24435-6, installer J-24435-4 and "C" clamp J-24435-7.
  2. Turn clamp in until bushing seats firmly. Be sure outer tube hole is to the front or forwards to the staked bushing.
- NOTICE:** Be sure spacer J-24435-6 is in position as shown in Figure 3C-26 to avoid collapsing control arm during assembly.
3. Stake front bushing at least in two places when installed.
  4. Insert the pivot shaft and install second bushing.
  5. Install the lower control arm to the vehicle as described under "Lower Control Arm - Installation", being sure to torque all fasteners to the proper specification.

### Lower Control Arm Installation

**NOTICE:** See NOTICE on page 1 of this section regarding the fasteners referred to in steps 2 and 3.

1. Install lower ball stud through steering knuckle and tighten nut.
2. Install spring and control arm as outlined under spring installation.
3. Torque lower control arm ball stud to specifications and install cotter pin.
4. Install brake caliper assembly if removed (see section 5).
5. Lower the vehicle to the floor.

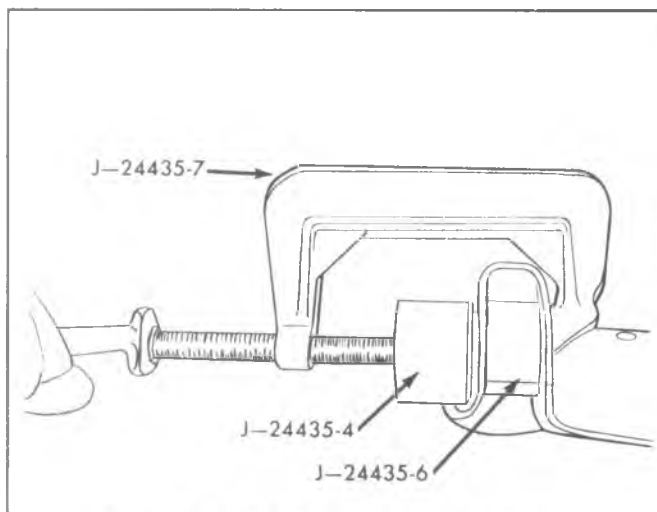

Fig. 3C-26--L.C.A. Rubber Bushing Installation

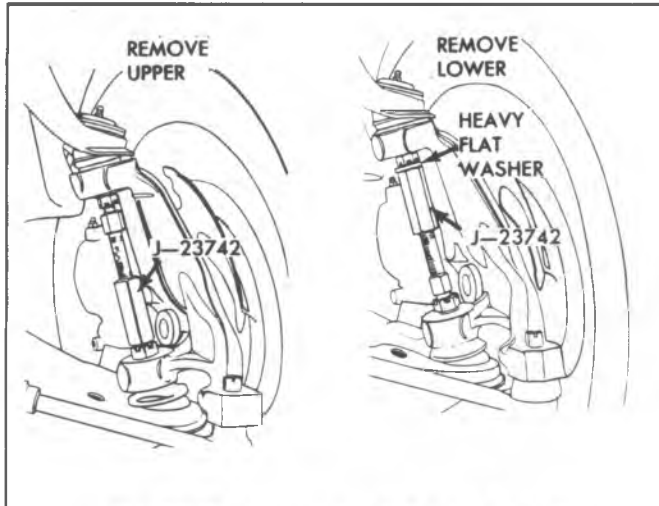

Fig. 3C-27--Disconnecting Ball Joints-Typical

## BALL JOINT SERVICE-ON VEHICLE

### Ball Joint-Inspection

The upper ball stud is spring loaded in its socket. This minimizes looseness at this point and compensates for normal wear, if the upper stud has any perceptible lateral shake, or if it can be twisted in its socket with the fingers, the upper ball joint should be replaced.

### Ball Joint Seals — Inspection

Ball joint seals should be carefully inspected for cuts and tears. Whenever cuts or tears are found, the ball joint must be replaced.

### Upper-Removal

1. Raise vehicle on hoist. If a frame hoist is used, it will be necessary to support the lower control arm with a floor jack.
2. Remove cotter pin from upper ball stud and loosen stud nut (two turns) but do not remove nut.
3. Install J-23742 between the ball studs as shown in Figure 3C-27.

It is necessary to remove the brake caliper assembly and wire it to the frame to gain clearance for tool J-23742. See section 5 for the proper procedure.

4. Be sure lower control arm is supported as pointed out in step 1. Extend bolt from Tool J-23742 to loosen ball stud in steering knuckle. When stud is loose, remove tool and stud nut.
5. Center punch rivet heads and drill out rivets.
6. Remove the ball joint assembly.

### Installation

**NOTICE:** See NOTICE on page 1 of this section regarding the fasteners referred to in steps 1, 3 and 6.

1. Install new service ball joint, using bolts and nuts supplied with joint, to upper arm. Torque nuts to 60 N·m (45 ft. lbs.).
2. Mate ball stud to steering knuckle and install stud nut.
3. Torque the ball stud nut as follows:
  - A. 10 Series 54-80 N·m (40-60 ft. lbs.) plus additional torque to align cotter pin not to exceed 120 N·m (90 ft. lbs.). Never back off to align cotter pin.
  - B. 20-30 Series 110-140 N·m (80-100 ft. lbs.) plus additional torque to align cotter pin not to exceed 175 N·m (130 ft. lbs.) Never back off to align cotter pin.
4. Install new cotter pin as shown in Figure 3C-28.
5. Install lube fitting and lube new joint.
6. Install brake caliper assembly if removed (see section 5).
7. Install tire and wheel assembly.
8. Lower the vehicle to the floor.

## Ball Joint-Inspection

### Lower

Lower ball joints are a loose fit when not connected to the steering knuckle. Wear may be checked without disassembling the ball stud, as follows:

1. Support weight of control arms at wheel hub and drum.
2. Accurately measure distance between tip of ball stud and tip of grease fitting below ball joint.
3. Move support to control arm to allow wheel hub and drum to hang free. Measure distance as in Step 2. If the difference in measurements exceeds 2.38 mm (.094" (3/32")) for all models, ball joint is worn and should be replaced (Fig. 3C-29).

### Lower-Removal

1. Raise vehicle on a hoist. If a frame hoist is used it will be necessary to support the lower control arm with a floor stand.
2. Remove the tire and wheel assembly.
3. Remove the lower stud cotter pin and loosen (two turns) but do not remove the stud nut.

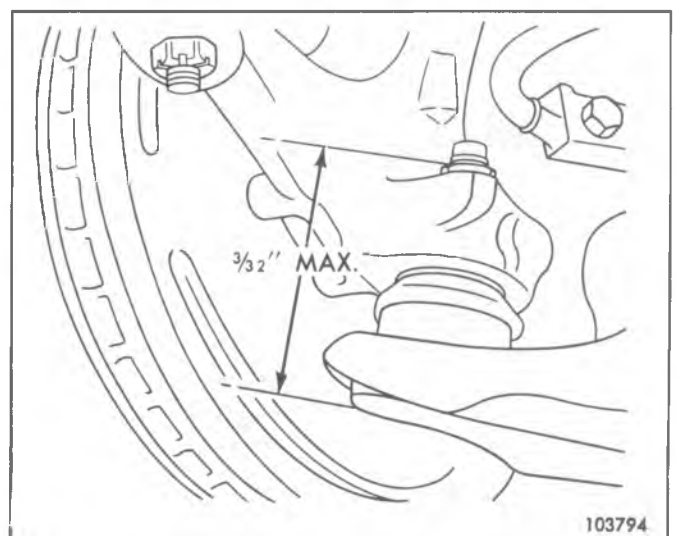

Fig. 3C-29--Checking Lower Ball Joint

4. Install J-23742 between the ball studs as shown in Figure 3C-27.

It may be necessary to remove the brake caliper assembly and wire it to the frame to gain clearance for tool J-23742. See section 5 for proper procedure.

5. Be sure lower control arm is supported as pointed out in Step 1. Extend bolt from Tool J-23742 to loosen ball stud in steering knuckle. When stud is loosened, remove tool and ball stud nut.
6. Pull the brake disc and knuckle assembly up off the ball stud and support the upper arm with a block of wood so that assembly is out of working area.

**NOTICE:** Do not put stress on the brake line flex hose or damage to the brake line may result.

7. Install Tools J-9519-10 and J-9519-2 and J-9519-29 as shown in Fig. 3C-30.
8. Turn hex head screw until ball joint is free of control arm.
9. Remove tools and the ball joint.

**Installation (Fig. 3C-31)**

**NOTICE:** See NOTICE on page 1 of this section regarding the fasteners referred to in steps 4, 5 and 7.

1. Start the new ball joint into the control arm and install J-9519-10 and J-9519-16 as shown. Position bleed vent in rubber boot facing inward.
2. Turn hex head screw until ball joint is seated in control arm.
3. Lower the upper arm and mate the steering knuckle to the lower ball stud.
4. Install brake caliper assembly if removed (see Section 5).
5. Install ball stud nut and torque as follows. All Series, 110 - 140 N·m (80-100 ft. lbs.) plus additional torque to align cotter pin hole not to exceed 175 N·m (130 ft. lbs.) maximum. Never back off to align cotter pin.
6. Install a lube fitting and lube the joint.
7. Install tire and wheel assembly and lower vehicle to floor.

**STEERING KNUCKLE**

It is recommended that vehicle be raised and supported as on a twin-post hoist so that the front coil spring remains compressed, yet the wheel and steering knuckle assembly remain accessible. If a frame hoist is used, support lower control arm with an adjustable jackstand to safely retain spring in its curb height position.

**Steering Knuckle-Inspection**

Inspect the tapered hole in the steering knuckle. Remove any dirt. If out-of-roundness, deformation, or damage is noted, the knuckle must be replaced.

**Removal**

1. Raise vehicle on hoist and support lower control arm as noted above.
2. Remove wheel and tire assembly.
3. Remove caliper as outlined under "Front Wheel Hub - Removal".
4. Remove disc splash shield bolts securing the shield to the steering knuckle. Remove Shield.
5. Refer to Section 3B-Steering for service removal operations.
6. Remove upper and lower ball stud cotter pins and loosen ball stud nuts. Free steering knuckle from ball studs by installing Special Tool J-23742. Remove ball stud nuts and withdraw steering knuckle.

**Installation**

**NOTICE:** See NOTICE on page 1 of this section regarding the fasteners referred to in steps 2, 3, 4 and 5.

1. Place steering knuckle in position and insert upper and lower ball studs into knuckle bosses. Steering knuckle hole, ball stud and nut should be free of dirt and grease before tightening nut.
2. Install ball stud nuts and tighten nut to specifications. (See Specification Section.)  
If necessary, tighten one more notch to insert cotter pins. Do not loosen nut to insert cotter pin. Refer to Ball Joint text for proper nut installation sequence.
3. Reverse remaining removal procedure, and tighten splash shield mounting bolt. Tighten two caliper assembly mounting bolts to 48 N·m (35 ft. lbs.) torque.
4. Adjust wheel bearings as outlined under Front Wheel Bearing Adjustment.
5. Tighten wheel nuts to 100 N·m (75 ft. lbs.).

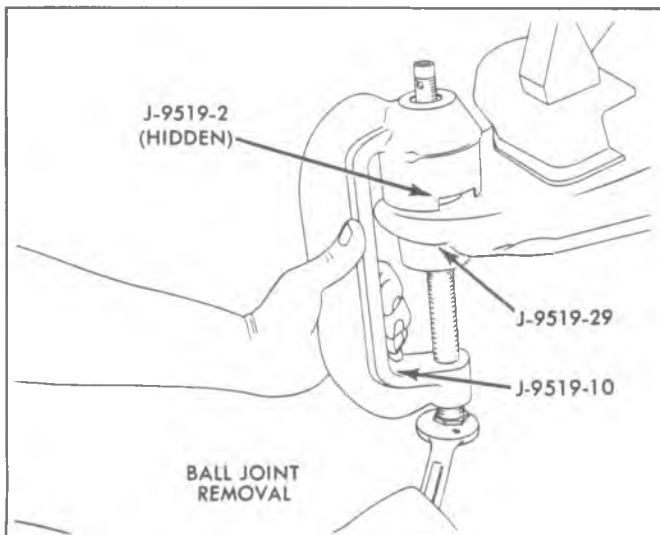

Fig. 3C-30--Ball Joint Removal

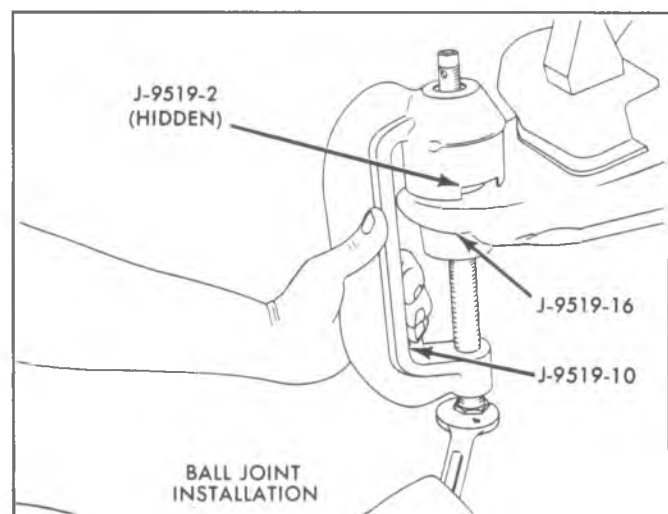

Fig. 3C-31--Installing Ball Joint

## CROSSMEMBER AND SUSPENSION UNIT

Component parts of the front suspension may be serviced separately as outlined in the preceding service operations. However, if extensive service is to be performed to crossmember, frame, etc., the unit can be removed and installed as follows:

### Removal (Fig. 3C-32)

1. Raise hood and disconnect negative battery cable from battery.
2. Raise vehicle on hoist.
3. Remove front wheels.
4. Disconnect front brake hose clip from each upper control arm.
5. Support front of vehicle with jack stands at frame side rails. Lower front hoist.
6. Clean area adjacent to brake hose fittings. Disconnect front brake hoses from calipers. Discard special washers (2 each hose). Cover disconnected end of each hose with suitable material.
7. Disconnect tie rod ends from steering knuckles. Discard cotter pins. Refer to Section 3B.
8. If equipped, disconnect front stabilizer from lower control arms.

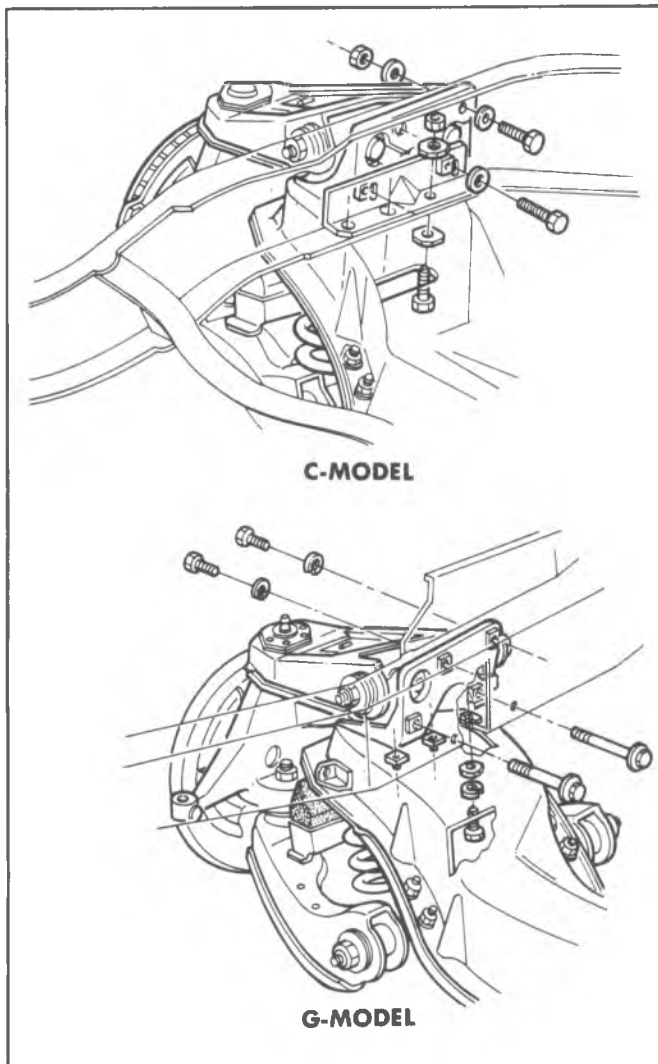

Fig. 3C-32--Suspension Unit to Frame

9. Disconnect front shock absorbers from lower control arms.
10. Remove brake line clip bolts from front suspension crossmember. On C-Models the clip is located under right hand engine mount support bracket.

**NOTICE:** Failure to disconnect these clips from the front suspension unit will result in severe damage to the brake line when unit is lowered from vehicle.

11. Remove engine mount support bracket to front suspension crossmember bolts.
12. Remove crossmember to lower frame rail bolts.
13. Raise hoist to support front suspension unit.
14. Support engine. Engine must be supported adequately before front suspension unit is lowered from vehicle.
15. Remove upper control arm bracket to frame side rail bolts. Suspension unit is now disconnected from vehicle.
16. Lower hoist to lower front suspension unit from vehicle.

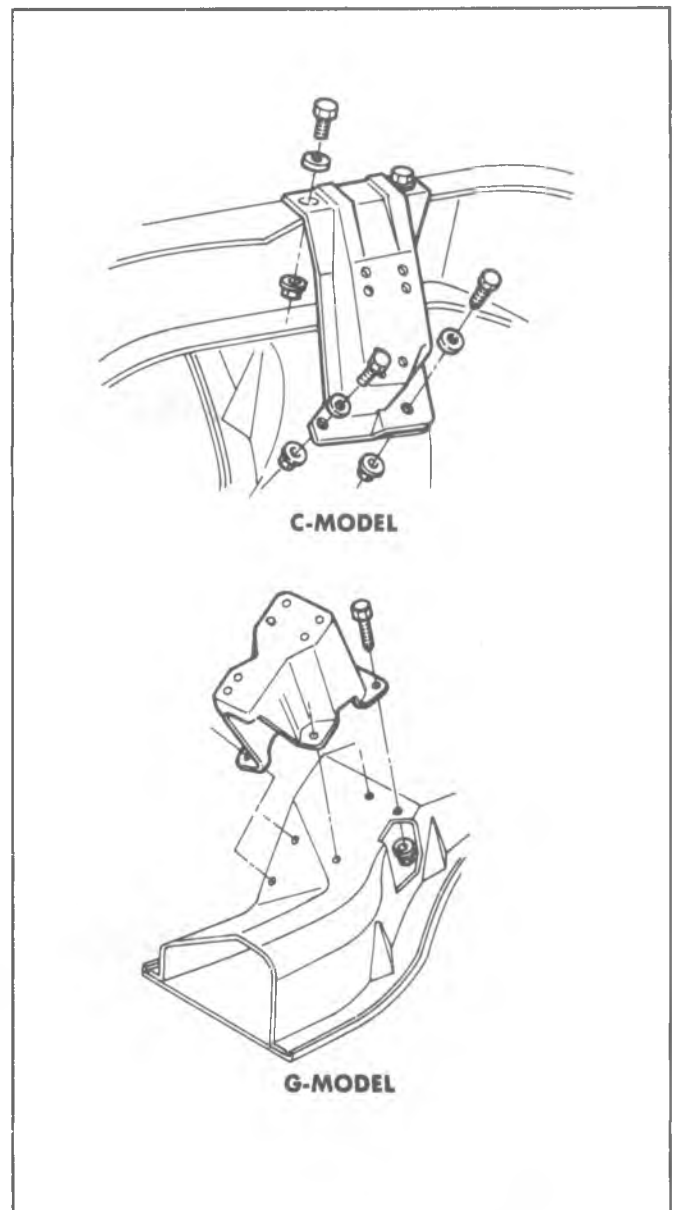

Fig. 3C-33--Engine Front Mounting Bracket

**Installation**

1. Raise hoist to align new suspension unit with frame rail holes.

**NOTICE:** See NOTICE, on page 1 of this section regarding fasteners referred to in steps 2-14.

2. Assemble (finger-tight) upper control arm bracket bolts and crossmember bolts to frame rails.
3. Torque upper control arm bracket bolts to frame side rails to 90 N·m (65 ft. lbs.). Control arm bracket bolts must be torqued before crossmember bolts are torqued. Crossmember must be in contact with siderails.
4. Torque crossmember bolts to frame lower rails 100 ft. lbs. Engine support can be removed at this time.
5. Lower hoist.
6. Assemble (finger-tight) engine mount support bracket to front suspension crossmember bolts.
7. Torque engine mount support bracket bolts to 48 N·m (35 ft. lbs.).

8. Install brake line clip bolt to front suspension crossmember. Torque to 17 N·m (150 in. lbs.) (C-models), 12 N·m (100 in. lbs.) (G-models).
9. Connect front shock absorbers to L.C.A.'s. Torque to 80 N·m (60 ft. lbs.) (C-models), 95 N·m (70 ft. lbs.) (G-models).
10. If equipped, connect front stabilizer to L.C.A.'s. Torque to 34 N·m (25 ft. lbs.).
11. Connect tie rod ends to steering knuckles. Refer to Section 3B.
12. Connect front brake hose to caliper, using new special washers. Refer to Section 5.
13. Connect front brake hose clips to upper control arms. Torque nuts to 17 N·m (150 in. lbs.).
14. Lubricate upper and lower ball joints.
15. Install front wheels.
16. Bleed brake system. Refer to Section 5 for correct bleeding procedures.
17. Lower vehicle.
18. Connect battery cable.

## FRONT SUSPENSION, FOUR-WHEEL DRIVE

### SERIES K10, K20, K30

#### INDEX

|                                   |       |                                  |       |
|-----------------------------------|-------|----------------------------------|-------|
| General Description.....          | 3C-23 | Spindle .....                    | 3C-30 |
| Maintenance and Adjustments ..... | 3C-26 | Steering Knuckle (K10, K20)..... | 3C-31 |
| Ball Joint Adjustment .....       | 3C-26 | Steering Knuckle (K30).....      | 3C-34 |
| Bearing Lubrication .....         | 3C-26 | Shock Absorber .....             | 3C-36 |
| Wheel Bearing Adjustment.....     | 3C-26 | Stabilizer Bar.....              | 3C-36 |
| Component Replacement .....       | 3C-27 | Leaf Spring.....                 | 3C-37 |
| Hubs, Automatic Locking.....      | 3C-27 | Specifications .....             | 3C-39 |
| Hub-and-Disc .....                | 3C-30 | Special Tools.....               | 3C-40 |

## GENERAL DESCRIPTION

### Knuckle Attachment

At the wheel ends of the axle tubes, two types of steering knuckle attachment are used. Figure 3C-1K shows the K10 and K20 knuckle attached with ball joints. Figure 3C-2K shows the king-pin attachment used in K30. The tapered upper king pin fits in a tapered nylon bushing. The

lower king pin is part of the bearing cap, and this king pin rides in a tapered roller bearing.

### Hub Design

An automatic locking hub is used on all models. This system, automatically engages the hub whenever four-wheel drive is selected.

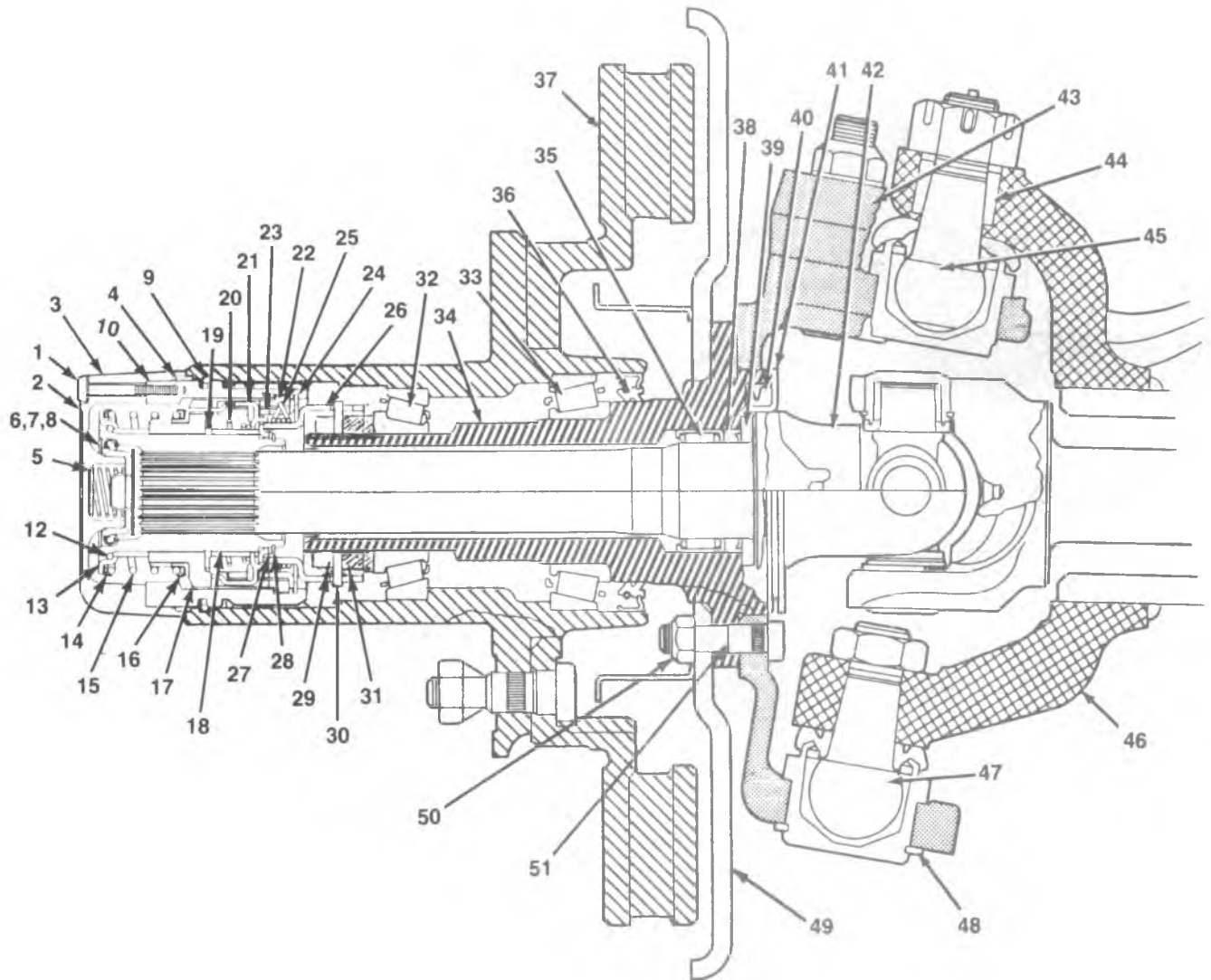

- |  |                             |                           |                             |
|--|-----------------------------|---------------------------|-----------------------------|
| 1. RETAINING SCREW                     | 14. SPRING RETAINER         | 27. SPACER                | 40. DUST SEAL               |
| 2. COVER PLATE                         | 15. RETURN SPRING           | 28. RETAINING RING        | 41. DEFLECTOR               |
| 3. COVER                               | 16. SPRING RETAINER         | 29. LOCK NUT              | 42. AXLE OUTER SHAFT        |
| 4. SEALING RING                        | 17. CLUTCH GEAR             | 30. RETAINING WASHER      | 43. KNUCKLE                 |
| 5. SPRING, BEARING RACE                | 18. HUB SLEEVE              | 31. ADJUSTING NUT         | 44. ADJUSTING SLEEVE        |
| 6. } BEARING ASSEMBLY                  | 19. 'C' TYPE RETAINING RING | 32. OUTER-WHEEL BEARING   | 45. UPPER BALL JOINT        |
| 7. } BEARING ASSEMBLY                  | 20. CONICAL SPRING          | 33. INNER-WHEEL BEARING   | 46. YOKE                    |
| 8. } BEARING ASSEMBLY                  | 21. CAM FOLLOWER            | 34. SPINDLE               | 47. LOWER BALL JOINT        |
| 9. WIRE RETAINING RING                 | 22. OUTER CAGE              | 35. SPINDLE BEARING       | 48. RETAINING RING          |
| 10. OUTER CLUTCH HOUSING               | 23. INNER CAGE              | 36. SEAL                  | 49. CALIPER SUPPORT BRACKET |
| 11. SEAL BRIDGE — RETAINER (NOT SHOWN) | 24. SNAP RING               | 37. HUB-AND-DISC ASSEMBLY | 50. SPINDLE RETAINING NUT   |
| 12. RETAINING RING                     | 25. BRAKE BAND              | 38. OIL SEAL              | 51. SPINDLE RETAINING BOLT  |
| 13. SPRING SUPPORT WASHER              | 26. DRAG SLEEVE AND DETENT  | 39. SPACER                |                             |

Fig. 3C-1K-K10, K20 with Auto. Locking Hub and Ball Joints

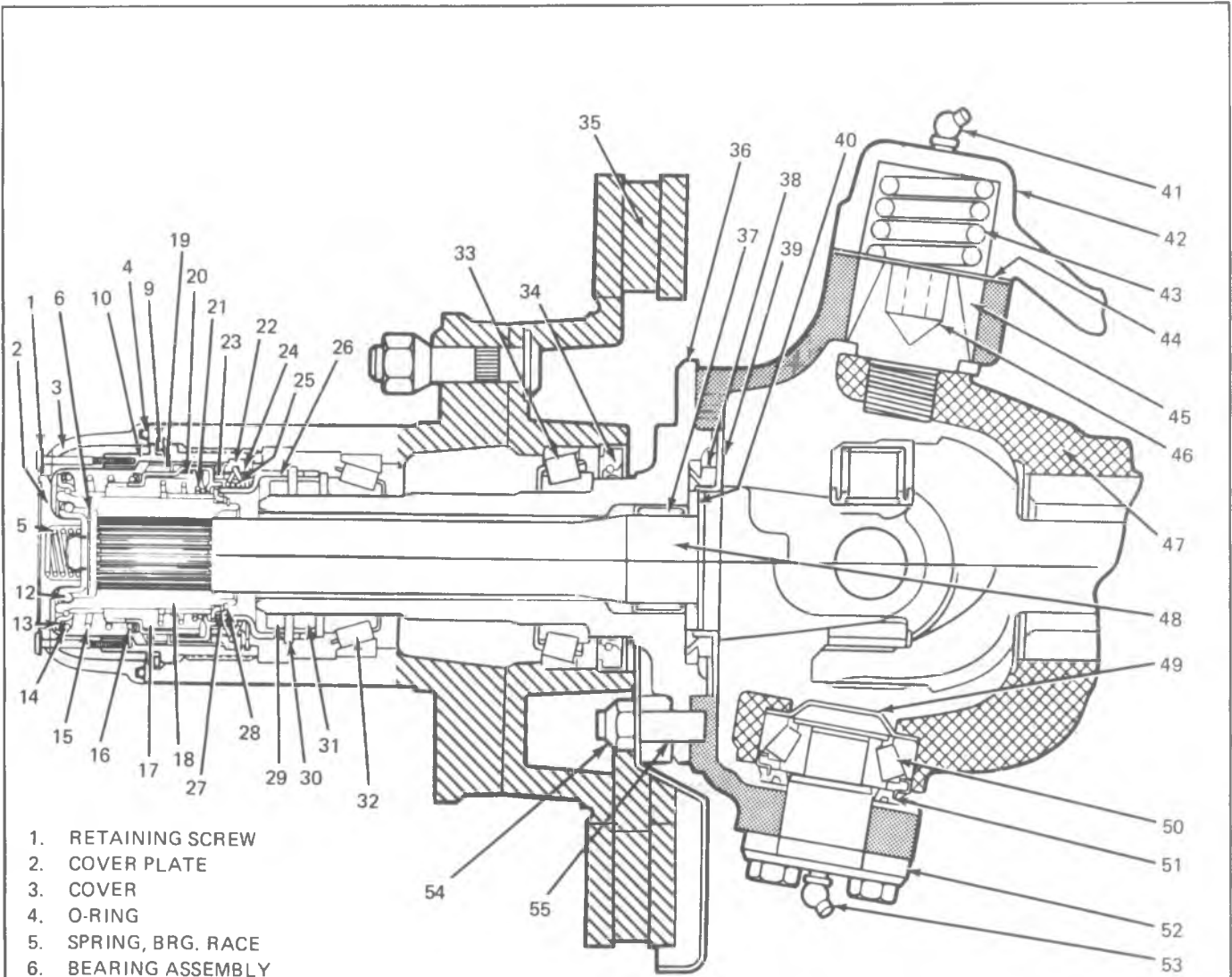

- |   |                             |                         |                            |
|---|-----------------------------|-------------------------|----------------------------|
| 1. RETAINING SCREW                      | 19. 'C' TYPE RETAINING RING | 31. ADJUSTING NUT       | 43. PRESSURE SPRING        |
| 2. COVER PLATE                          | 20. CONICAL SPRING          | 32. OUTER-WHEEL BEARING | 44. GASKET                 |
| 3. COVER                                | 21. CAM FOLLOWER            | 33. INNER-WHEEL BEARING | 45. BUSHING, KING-PIN      |
| 4. O-RING                               | 22. OUTER CAGE              | 34. SEAL                | 46. KING-PIN               |
| 5. SPRING, BRG. RACE                    | 23. INNER CAGE              | 35. HUB-AND-DISC ASM    | 47. YOKE                   |
| 6. BEARING ASSEMBLY                     | 24. SNAP RING               | 36. SPINDLE             | 48. OUTER AXLE SHAFT       |
| 9. WIRE RETAINING RING                  | 25. BRAKE BAND              | 37. SPINDLE BEARING     | 49. GREASE RETAINER        |
| 10. OUTER CLUTCH HOUSING                | 26. DRAG SLEEVE AND DETENT  | 38. SEAL                | 50. LOWER BEARING          |
| 11. SEAL BRIDGE -- RETAINER (NOT SHOWN) | 27. SPACER                  | 39. DEFLECTOR           | 51. SEAL                   |
| 12. RETAINING RING                      | 28. RETAINING RING          | 40. SPACER              | 52. BEARING CAP            |
| 13. SPRING SUPPORT WASHER               | 29. LOCK NUT                | 41. LUBE FITTING        | 53. LUBE FITTING           |
| 14. SPRING RETAINER                     | 30. RETAINING WASHER        | 42. UPPER BEARING CAP   | 54. SPINDLE ATTACHING NUT  |
| 15. RETURN SPRING                       |                             |                         | 55. SPINDLE ATTACHING BOLT |
| 16. SPRING RETAINER                     |                             |                         |                            |
| 17. CLUTCH GEAR                         |                             |                         |                            |
| 18. HUB SLEEVE                          |                             |                         |                            |

Fig. 3C-2K--K30 with Auto. Locking Hub and King-Pins



## MAINTENANCE AND ADJUSTMENTS

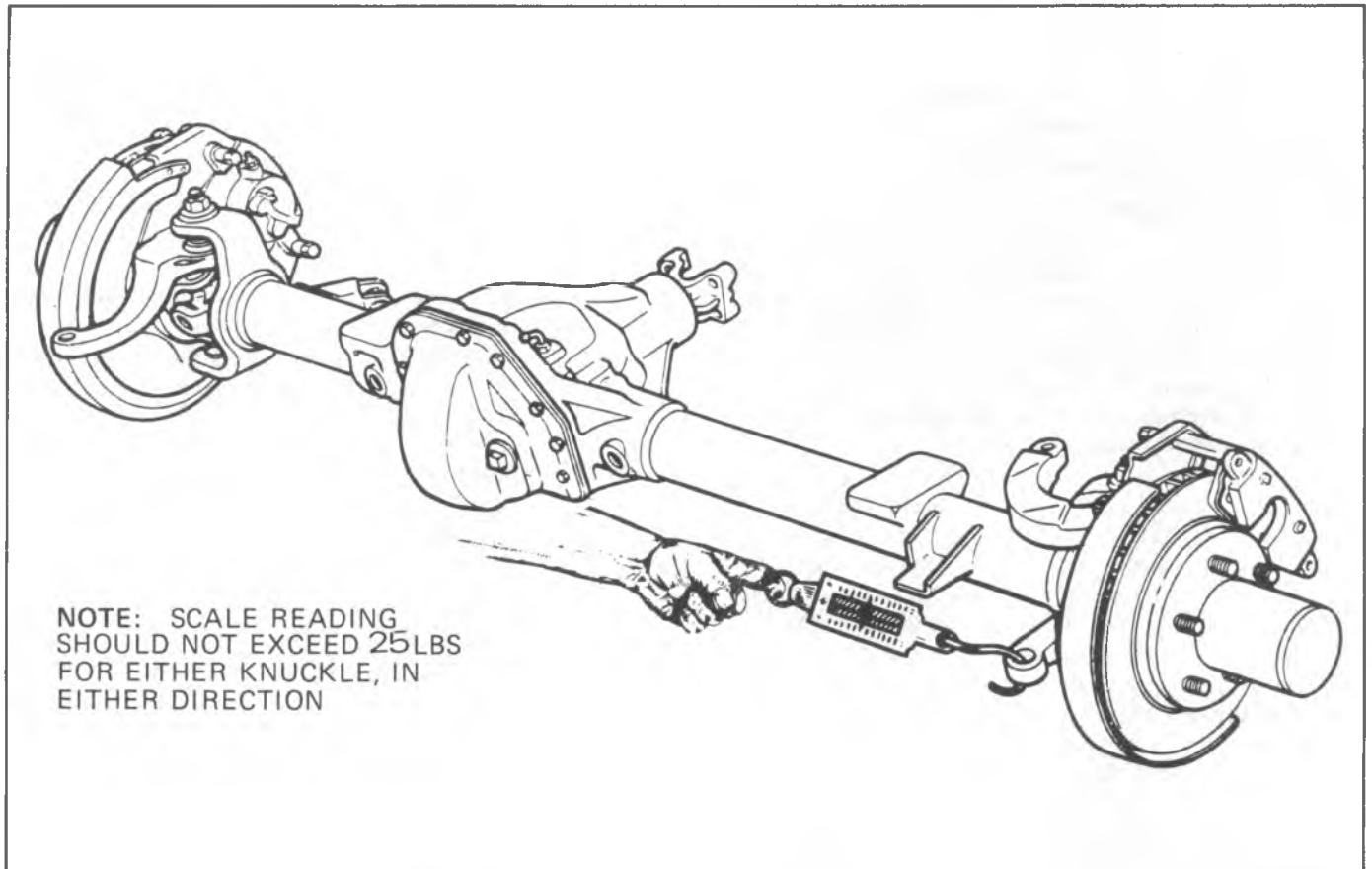

Fig. 3C-3K--Determining Front Axle Ball Joint Turning Effort

### BALL JOINT TURNING EFFORT (K10, K20)

1. Raise vehicle on hoist then place jack stands just inside of front springs.
2. Disconnect connecting rod and tie rod to allow independent movement of each steering knuckle.
3. Apply a fish-scale to the tie rod mounting hole of the steering knuckle arm. With the knuckle assembly in the straight-ahead position, determine the right angle pull required to keep the knuckle assembly turning after initial break-away. Refer to fig. 3C-15K for Ball Stud Sleeve Adjustment. This pull should not exceed 25 lbs., for each knuckle assembly, in either direction. See Figure 3C-3K.

### BEARING LUBRICATION

#### Front Wheel Bearings

#### Spindle Bearings

Whenever front wheel bearings are lubricated, the spindle needle bearings should also be lubricated, with the same chassis grease. Under normal conditions, the lubrication interval should be 12,000 miles; off-road use such as in mud or water will require shorter intervals. The

spindle bearings are accessible after removing the spindle, as shown in Figure 3C-6K.

### WHEEL BEARING ADJUSTMENT

1. After lubricating the wheel bearings and the spindle bearings, install the hub-and-disc, and the outer wheel bearing to the spindle.
2. Torque the inner adjusting nut to 50 foot pounds, (60 N·m) while rotating the hub-and-disc to seat the bearings. Use Tool J-6893 and Adapter J-23446 or J-6893-01 for K10, K20; use J-26878 for K30. Back off the inner adjusting nut and retorque to 35 ft. lbs. (47 N·m) while the hub is being rotated.
3. Back off the inner adjusting nut again 3/8 turn maximum. Assemble the drag sleeve retainer washer over the axle shaft against the bearing adjusting nut (Item #30, Fig. 3C-3K). The tang on the inside diameter of this washer is assembled in the keyway of the spindle. The pin on the inner nut (Item #31) MUST pass through one of the holes in the retainer washer. Assemble and tighten the outer lock nut to 217-310 N·m (160-205 lb. ft.).  
Hub assembly should have .025 to .254 mm (.001 to .010 inch) end play.
4. Install the locking hub assembly. Refer to hub assembly and installation procedures.

## COMPONENT REPLACEMENT

### HUB REPLACEMENT

**NOTICE:** See NOTICE on page 1 of this section, regarding the fasteners in the following procedures for Locking Hub Replacement.

#### AUTOMATIC LOCKING HUBS

##### General Description (All Models)

The Automatic Locking Hub, shown in Fig. 3C-4K, engages or disengages to lock the front axle shaft to the hub of the front wheel. Engagement occurs whenever the vehicle is operated in four-wheel drive. Disengagement occurs whenever two-wheel drive has been selected and the vehicle is moved rearward. Disengagement will not occur when the vehicle is moved rearward if four-wheel drive is selected and the hub has already been engaged.

The outer clutch housing is splined to the wheel. The hub sleeve is splined to the front axle shaft. The clutch gear is splined to the hub sleeve. The drag sleeve is keyed to the wheel bearing retainer washer. Engagement occurs when the clutch gear is moved on the splines of the hub sleeve to engage the internal teeth of the outer clutch housing.

The cam surface of the steel inner cage forces the cam follower and clutch gear to move outward toward the cover and into engagement with the clutch teeth of the outer clutch housing. A lug on the inside of the drag sleeve retainer washer keys the washer to the spindle and two lock nuts retain this washer in position on the spindle. Cutouts in the drag sleeve engage the four tabs on the drag sleeve retainer washer to hold the drag sleeve in a fixed position with respect to the axle shaft. The one way clutch spring (called a brake band) is positioned over the serrated portion of the drag sleeve.

Engagement is accomplished (when four-wheel drive is selected) by the movement of the axle shaft, causing one of the tangs of the brake band to engage the steel outer cage and hold the cage while the cam follower moves the clutch gear into mesh with the outer clutch housing. One of the tangs of the brake band is used for engagement. The other tang is used to maintain free motion of the brake band relative to the drag sleeve during four-wheel drive operation (after the hub lock engages). Disengagement is accomplished (after two-wheel drive has been selected) by the reverse movement of the wheel causing the clutch gear, hub sleeve, and cam follower to rotate. The cam follower rotates away from the lugs of the plastic outer cage, allowing the follower to move to the disengaged condition. The release spring then moves the clutch gear out of mesh with the outer clutch housing to disengage the wheel from the axle shaft.

##### Preliminary Checking

Before disassembling a unit for complaint of abnormal noise, read the following:

- To obtain all-wheel drive, the transfer case lever must be placed in (4L) or (4H), at which time the hub locks will automatically engage.
- To unlock (free wheel) the hubs, shift the transfer case lever to (2H), then slowly reverse vehicle direction approximately ten feet.
- Incomplete shift from 2WD to 4WD, or disengagement of only one hub lock may cause an abnormal sound

from the front axle. Shift to 4WD to stop the noise, then unlock the hubs as described above.

- To avoid breaking plastic parts, allow assembly to come to room temperature before disassembling.

##### Removal of Hub Lock Assembly

1. Remove the five screws (item #1, Fig. 3C-4K) which retain the cover (#3) to the outer clutch housing (#10).
2. Remove the cover, seal (#4), seal bridge (#11), and bearing components (#5, 6, 7, 8).
3. Use needle-nose pliers to compress the wire retaining ring (#9), and pull the remaining components from the wheel.

##### DISASSEMBLE LOCKING HUB COMPONENTS

1. Remove the snap ring (#28) from the groove of the hub sleeve (#18).
2. Turn the clutch gear (#17) until it drops into engagement with the outer clutch housing (#10). Lift and cock the drag sleeve (#26) to unlock the tangs of the brake band (#25) from the window of the inner cage (#23) and remove drag sleeve and brake assembly.

It is important that the brake band should never be removed from the drag sleeve. The spring tension of the brake band can be changed if the coils are over-expanded and this could affect the operation of the hub.

3. Remove the snap ring (#24) from the groove in the outer clutch housing.
4. Use a small screwdriver to pry the plastic outer cage (#22) free from the inner cage (#23) while the inner cage is being removed.
5. Use a small screwdriver to pry the plastic outer cage tabs free from the groove in the outer clutch housing. Remove outer cage.
6. Remove the clutch sleeve (#18) and attached components from the outer clutch housing.
7. Compress the return spring (#15) and hold the spring in the compressed condition with fabricated clamps as shown in Fig. 3C-5K. After the clamps are installed, position the entire assembly in a bench vise so that the vise holds both ends of the clutch sleeve. Remove the retaining ring (#12).
8. With the clutch sleeve assembly still in the vise, remove the clamps holding the return spring. Slowly open the vise to permit releasing of the return spring in a controlled manner. Remove the retainer seat, spring and spring support washers (#13, 14) from the hub sleeve.
9. Remove the C-type retaining ring (#19) from the clutch sleeve. It is necessary to position the sleeve assembly so that the C-ring ends are aligned with the legs of the cam follower, allowing removal between the two legs.
10. Remove the conical spring (#20) from between the cam follower and the clutch gear.
11. Separate the cam follower (#21) from the clutch gear (#17).

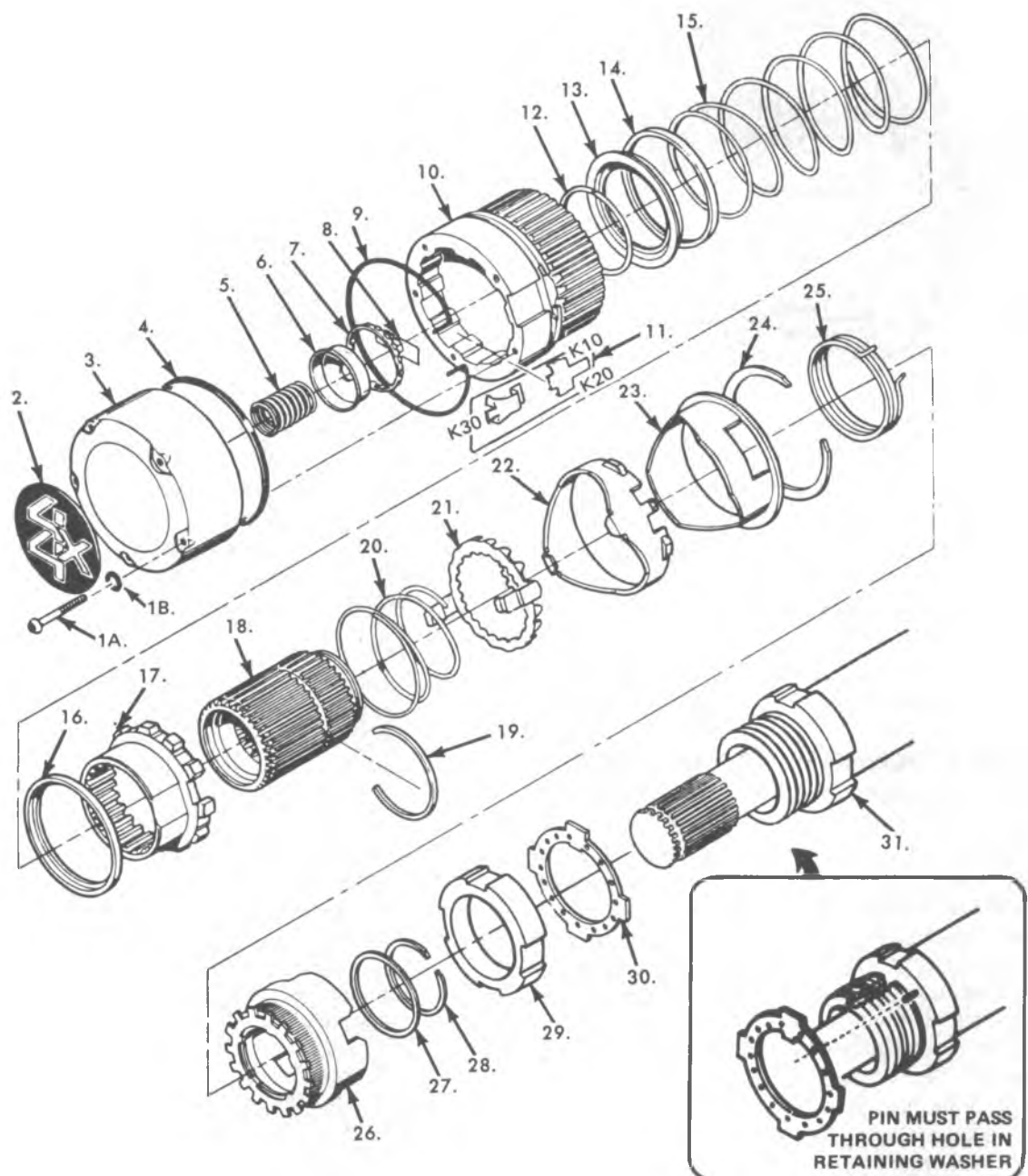

1A. Machine Screw  
1B. O-Ring Seal

2. Cover Plate  
3. Cover  
4. Sealing Ring  
5. Bearing Race Spring  
6. Bearing Inner Race  
7. Bearing  
8. Bearing Retainer Clip  
9. Wire Retaining Ring  
10. Outer Clutch Housing

11. (K10-20) Seal Bridge-Retainer  
(K30) Assembly Aid-Retainer

12. Retaining Ring  
13. Spring Support Washer  
14. Spring Retainer  
15. Return Spring  
16. Spring Retainer  
17. Clutch Gear  
18. Hub Sleeve  
19. "C" Type Retaining Ring  
20. Conical Spring

21. Cam Follower  
22. Outer Cage

23. Inner Cage  
24. Snap Ring  
25. Brake Band  
26. Drag Sleeve and Detent  
27. Small Spacer  
28. Retaining Ring  
29. Lock Nut  
30. Drag Sleeve Retainer Washer  
31. Adjusting Nut, Wheel Bearing

Fig. 3C-4K--Automatic Locking Hubs

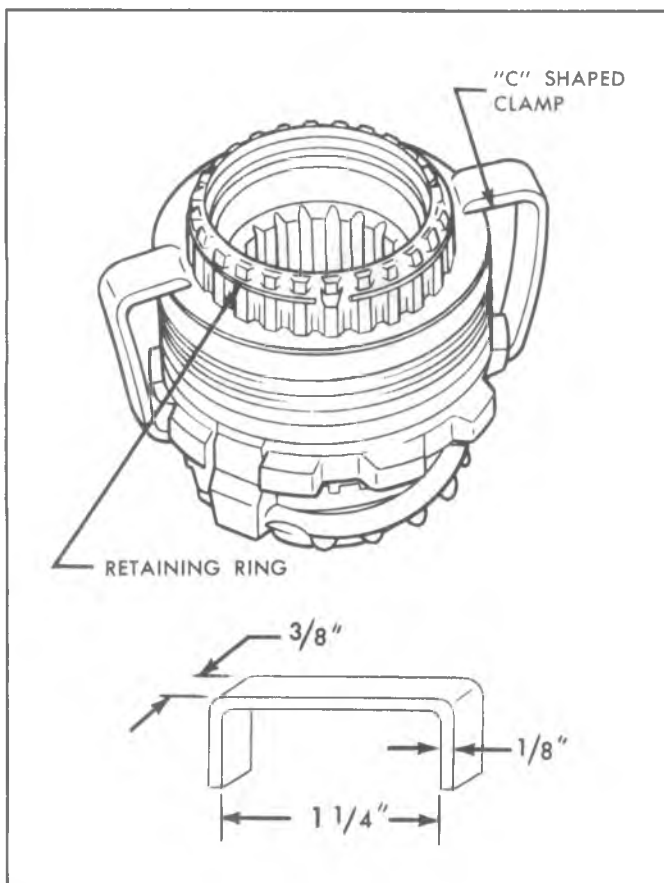

Fig. 3C-5K--Using Clamp and Vise to Compress Return Spring

### REASSEMBLE LOCKING HUB COMPONENTS

1. Snap the tangs of the cam follower (#21) over the flats of the clutch gear (#17).
2. Compress the conical spring (#20) and slide it into position with the large diameter of the spring located against the clutch gear.
3. Position the clutch gear assembly over the splines of the hub sleeve ((#18). The teeth of the cam follower should be located at the end of the hub sleeve which has no splines. The clutch gear and spring should slide freely over the splines of the hub sleeve.
4. Assemble the "C" shaped retainer ring (#19) in the groove of the hub sleeve.
5. Assemble a spring retainer (#14, 16) over each end of the return spring (#15).
6. Position one end of the return spring with retainer (#16) against the shoulder of the clutch gear.
7. Place the spring support washer (#13) against the retainer on the end of the return spring. Compress the return spring and assemble the retainer ring (#12) in the groove of the hub sleeve. Two "C" shaped clamps may be used to retain the return spring while the retainer ring is being assembled. Refer to Fig. 3C-4K.
8. The two "C" shaped clamps may be fabricated from 3/8" (9.5mm) wide by 3/32" or 1/8" (2.4-3.2mm) thick stock. The distance between the two legs of the clamps should be approximately 1-1/4" (31.8mm).

9. Place the components assembled in steps 1 through 7 into the outer housing (#10). The cam follower should be positioned with the two legs directed outboard.
10. Screw three of the cover screws (#1) into three holes of the outer clutch housing. These screws will support the component to permit the clutch hub to drop down so that the tangs of brake band (#25) may be assembled.
11. Carefully work the plastic outer cage (#22) into the outer clutch housing with the ramps facing toward the cam follower. The small external tabs of the plastic cage should be located in the wide groove of the outer clutch housing.
12. Assemble the steel inner cage (#23) into the outer cage, aligning the tab of the outer cage with the "window" of the inner cage.
13. Assemble the retaining ring (#24) into the groove of the outer clutch housing above the outer cage.
14. The brake band and drag sleeve are serviced as an assembly.

In the event that the original lubricant has been removed or contaminated, Part No. 14050324, or equivalent, MUST be used to lubricate this assembly. DO NOT USE any other type lubricant.

15. Assemble one of the two tangs of the brake band (#25) on each side of the lug of the outer cage which is located in the window of the steel inner cage. It will be necessary to cock these parts to engage the tangs in this position as the drag sleeve is positioned against the face of the cam follower.
16. Remove the three screws and rest the end of the hub sleeve on a suitable support. Assemble the washer (#27) and snap ring (#28) above the drag sleeve. The following steps may be completed as hub is assembled to vehicle.
17. Assemble the wire retaining ring (#9) in the groove in the unsplined end of the outer clutch housing. The tangs of the retainer ring should point away from the splined end of the clutch housing.
18. Hold the tangs of the wire retainer together and assemble Item #11 over the tangs. This holds the wire retainer ring in a clamped condition in the groove of the outer clutch housing. For K10 and K20, assemble the "O" ring in the groove of the outer clutch housing and over seal bridge.
19. Assemble the bearing (#7) over the inner race (#6). Lubricate the bearing as it is assembled with light wheel bearing grease. The steel balls should be visible when bearing is properly assembled.
20. Snap the bearing retainer clip (#8) into the hole in the outer race.
21. Assemble the bearing and retainer assembly in the end of the hub sleeve. Assemble the seal ring (#4) over the outer clutch housing.
22. Assemble the bearing race spring (#5) into the bore in the cover.
23. Assemble the cover and spring assembly. Align the hole in the cover to the holes in the outer clutch housing and assemble the five screws.
24. For K10 and K20, assemble the O-ring over the seal

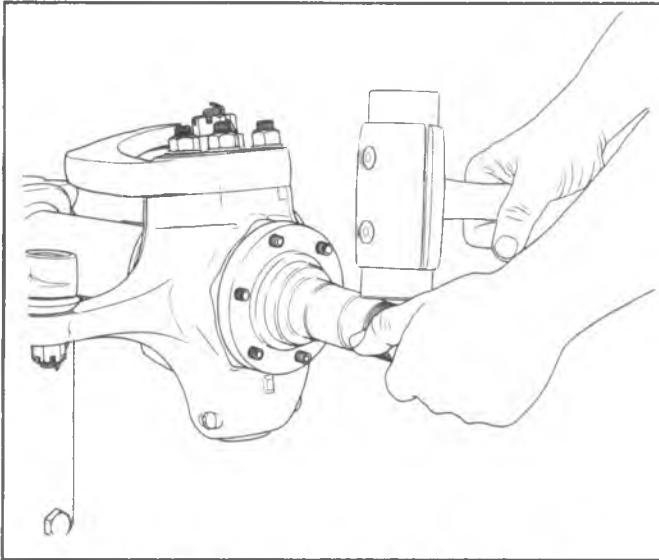

Fig. 3C-6K--Removing Spindle and Thrust Washer

bridge (Item #11) to prevent it from jumping out of position during handling prior to the hub bearing assembled to the vehicle. This "O" ring may be left on but is not required.

25. The hub sleeve and attached parts should turn freely after the unit has been completely assembled.
26. The five cover screws must be loosened to assemble the hub to the vehicle. Torque these screws after hub is installed to 4.5-5.6 N·m (40-50 in-lbs.).

### Assemble New Hub to Wheel

27. A drag sleeve retainer washer (#30) is supplied with each new assembly. Assemble this washer between the wheel bearing adjustment nut and the lock nut. Adjust the inner nut to give proper bearing adjustment as follows.
28. Use J-6893 to torque adjusting nut (#31) to 60 N·m (50 ft. lbs.), to seat the bearings; then, back off the nut and torque to 47 N·m (35 ft. lbs.) while the hub is being rotated. Finally, back the adjusting nut off a maximum of 3/8 turn. Assemble the drag sleeve retainer washer (Item #30) over the axle shaft against the bearing adjustment nut. The tang on the inside diameter of this washer is assembled in the keyway of the axle shaft. The pin on the adjusting nut **MUST** pass through one of the holes in the washer. Assemble and tighten the outer lock nut to 217-310 N·m (160-205 lb-ft).
29. Align the cut-outs in the drag sleeve with tabs on the drag sleeve washer as the splines of the outer clutch housing are assembled into splines of the hub of the wheel. Loosen the cover screws three or four turns and push in on these screws, to allow the retaining ring to expand into groove in hub of wheel as the seal bridge is forced from position over the retaining ring as the tang of seal bridge contacts wheel hub. Torque the cover screws to 4.5-5.6 N·m (40-50 lb. in.)

### Assemble a Rebuilt Hub to Wheel

30. Steps 1-17 in the assemble procedure are usually completed whenever the hub is rebuilt and then assembled to the wheel.

31. Hold the two tangs of the retaining ring in the clamped condition as the assembled components are assembled to the hub of the wheel. See step 29 for installation of drag sleeve washer.
32. Assemble the retainer (Item #11) in the cut-out of the outer clutch housing. For K10 and K20, assemble the sealing ring over the outer clutch housing.
33. Assemble the bearing and retainer assembly into the hub sleeve.
34. Assemble the bearing race spring to the cover.
35. Assemble the cover and cover bolts. Be sure that O-rings are in position under the bolts. Tighten cover screws to 4.5-5.6 N·m (40-50 lb. in.).

## HUB-AND-DISC

### Removal

1. Remove automatic locking hub as described earlier.
2. Remove the wheel bearing outer lock nut, retaining washer, and wheel bearing inner adjusting nut using Tool J-6893 and Adapter J-23446 or Tool J-6893-01.
3. Remove the hub-and-disc assembly and the outer wheel bearing.
  - a. Remove the oil seal and inner bearing cone from the hub using a brass drift and tapping with a hammer. Discard the oil seal.
  - b. Remove the inner and outer bearing cups using a brass drift and hammer.
  - c. Clean, inspect and lubricate all parts as required.

### Installation of Hub-and-Disc

**NOTICE:** All parts should be lubricated for normal operation during assembly with an ample amount of high speed grease. Lubrication **MUST** be applied to prevent deterioration before the unit is placed in service.

1. Assemble the outer wheel bearing cup into the wheel hub using Installer J-6368 and Driver Handle J-8092.
2. Assemble the inner wheel bearing cup into the wheel hub using Installer J-23448 and Driver Handle J-8092.
3. Pack the wheel bearing cone with a high melting point type wheel bearing grease and insert the cone into the cup.
4. After lubricating the wheel bearings, install the hub-and-disc and the bearings to the spindle.
5. Adjust wheel bearings as listed in "Maintenance and Adjustments".

## SPINDLE

### Removal

1. Remove the hub-and-disc assembly as outlined earlier.
2. Remove the spindle retaining bolts.
3. Remove the spindle and thrust washer by tapping the end of the spindle lightly with a soft hammer to break it loose from the knuckle as shown in Figure 3C-6K. Replace the thrust washer if excessive wear has occurred.

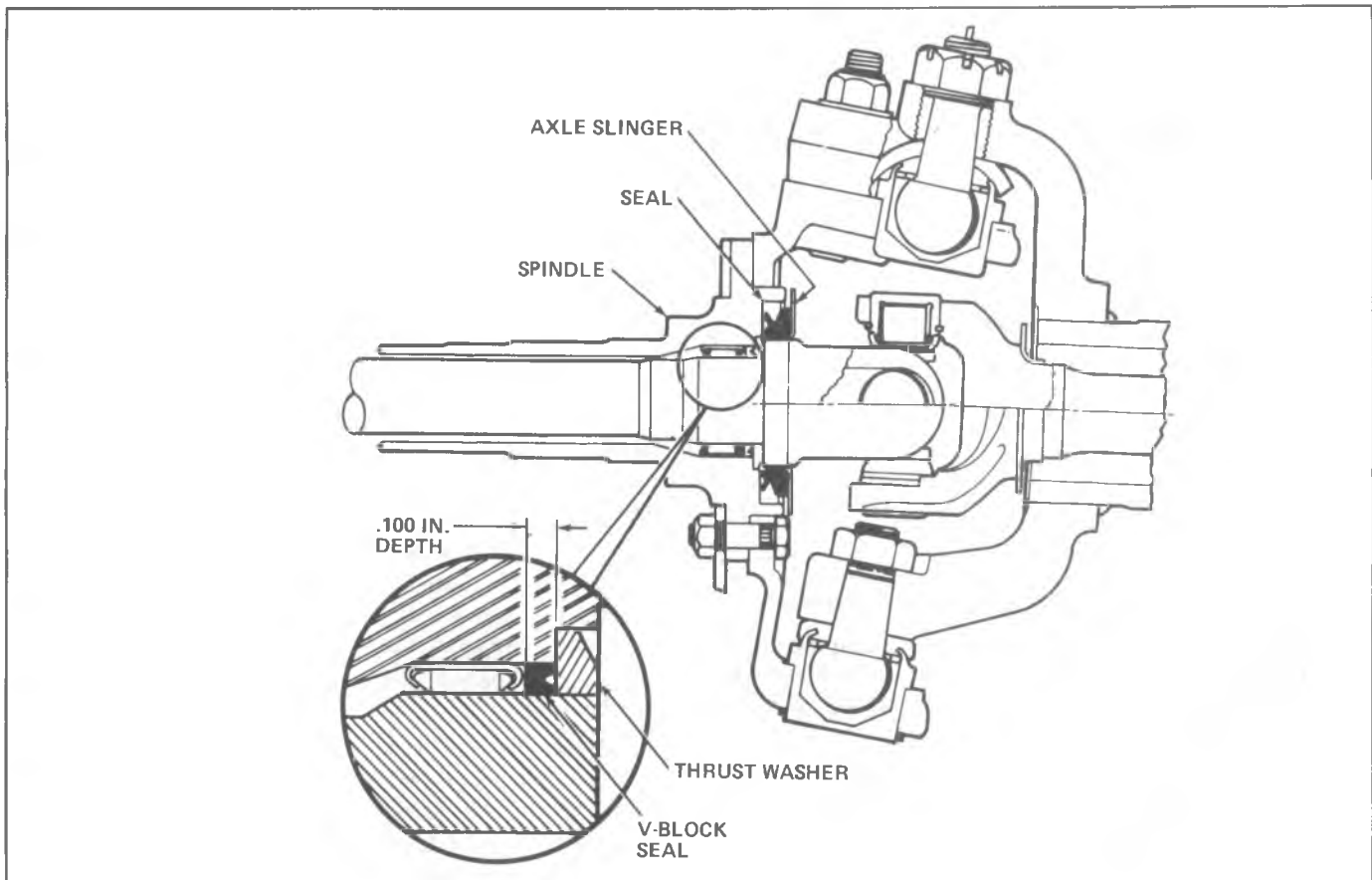

Fig. 3C-7K--Front Spindle Grease Seals

**Servicing Spindle Components**

When servicing the spindle check the spindle grease seals (Fig. 3C-7K).

1. Secure the spindle in a vise by locating on the high step diameter. Be sure that the machined surface of the spindle will not be damaged by the vise jaws.
2. Remove the oil seal.
3. Remove the needle roller bearing.
4. Place the spindle in a vise on the high step and

install needle roller bearing.

- a. Use J-23445 and Drive Handle J-8092 for K10, K20.
- b. Use J-21465-17 for K-30.

5. Install grease seal onto slinger with lip toward spindle.
6. Relubricate the needle bearing and the spindle end with a high melting point type wheel bearing grease.

**Installation**

1. Install the thrust washer over the axle shaft with the chamfer toward the slinger and install the spindle as shown in Figure 3C-8K.
2. Assemble spindle to knuckle. Use **new** spindle nuts and torque to 88 N·m (65 lb. ft.).

**NOTICE:** See NOTICE on page 1 of this section.

**KNUCKLE - K10, K20 (WITH BALL JOINTS)**

**Removal**

1. Remove the automatic locking hub, hub-and-disc assembly, and spindle components as outlined earlier.
2. If the steering arm is to be removed, disconnect the tie rod.
  - a. Remove cotter pin.
  - b. Loosen tie rod nuts and tap on nut with a soft hammer to break the studs loose from the knuckle arm.
  - c. Remove nuts and disconnect the tie rod. If it is necessary to remove the steering arm, discard the

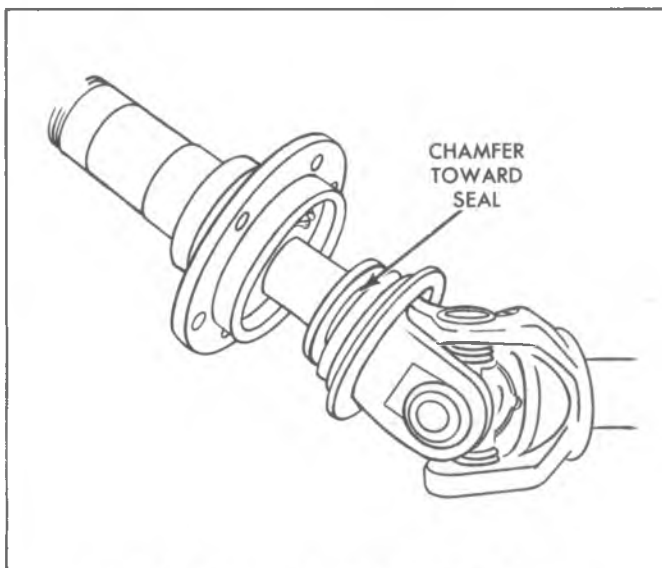

Fig. 3C-8K--Installing Spindle and Thrust Washer

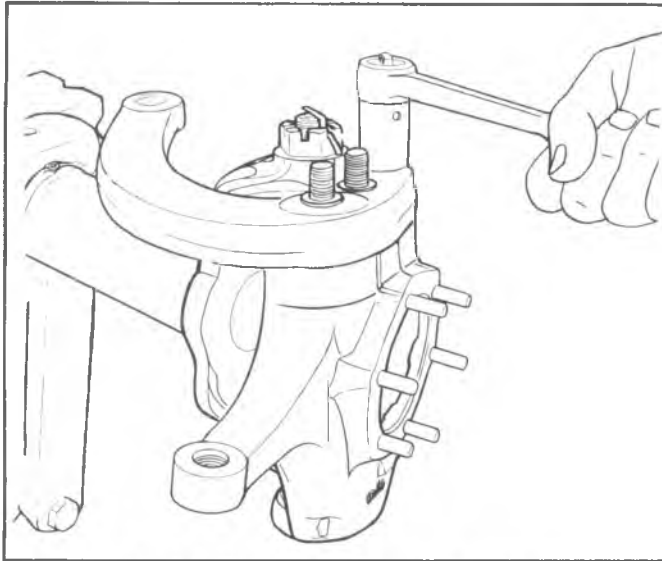

Fig. 3C-9K--Removing Steering Arm Nuts

self-locking nuts (Fig. 3C-9K) and replace with new nuts at assembly.

3. Remove the cotter pin from the upper ball socket nut.
4. Remove the retaining nuts from the upper and lower ball sockets as shown in Figure 3C-10K.
5. Remove the knuckle assembly from the yoke by inserting a suitable wedge-shaped tool between the lower ball stud and the yoke and tapping on the tool to release the knuckle assembly. Repeat as required at the upper ball stud location.

**Ball Joint Service**

**NOTICE:** Do not remove the yoke upper ball stud adjusting sleeve unless new ball studs are being installed. If it is necessary to loosen the sleeve to remove the knuckle, do not loosen it more than two threads using Spanner J-23447 as shown in Figure 3C-15K. The nonhardened threads in the yoke can be easily damaged by the hardened threads in the adjusting sleeve if caution is not used during knuckle removal.

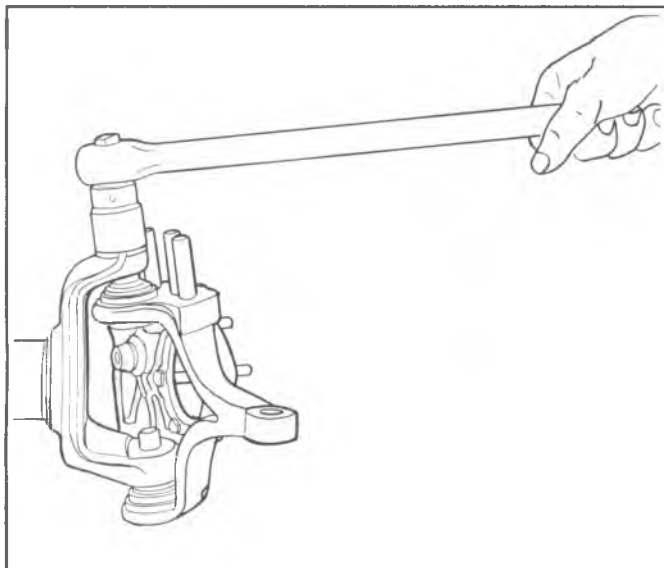

Fig. 3C-10K--Removing Ball Socket Retaining Nut

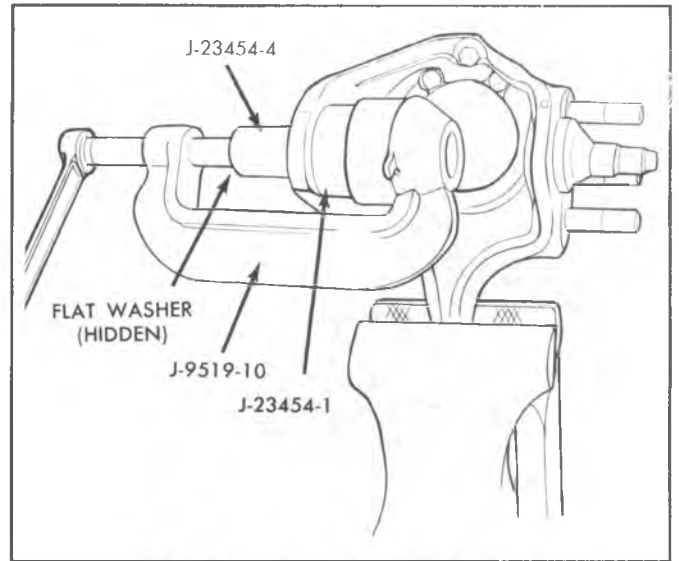

Fig. 3C-11K--Removing Lower Ball Joint

- On the LH knuckle, it is necessary to remove the steering arm before servicing the upper ball joint.
- Remove the lower ball joint snap ring before beginning. Lower ball joint must be removed before any service can be performed on the upper ball joint.

1. Remove the lower ball joint using tools J-9519-10, J-23454-1, and sleeve J-23454-4 or equivalent as shown in Figure 3C-11K.

If Tool J-23454-4 is not available, a suitable tool may be fabricated from 2-3/8" O.D. steel tubing with a minimum of 2-1/16" I.D., cut 63.50mm (2-1/2") long.

2. Remove the upper ball joint using tools J-9519-10, J-23454-1, and sleeve J-23454-4 or equivalent as shown in Figure 3C-12K.
3. Install the lower ball joint into the knuckle. Make sure that the lower ball joint (the joint without cotter pin hole in the stud end) is straight. Press the stud into the knuckle until properly seated using tools J-9519-10, J-23454-2, and J-23454-4 or equivalent as shown in Figure 3C-13K and install snapping.

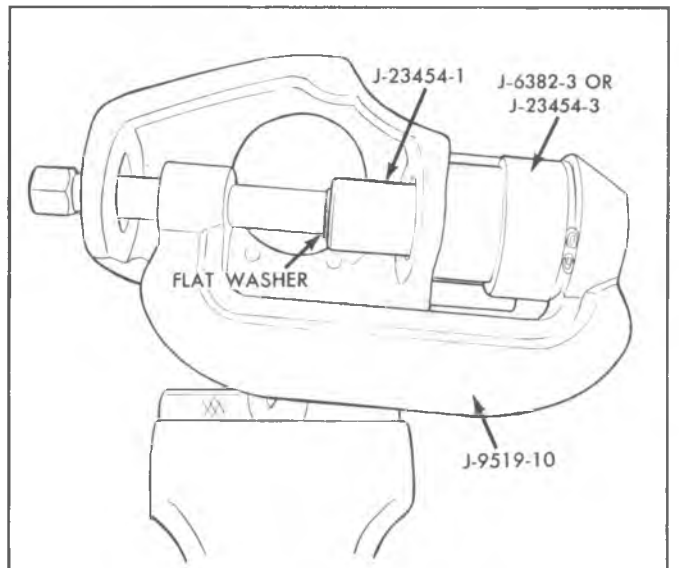

Fig. 3C-12K--Removing Upper Ball Joint



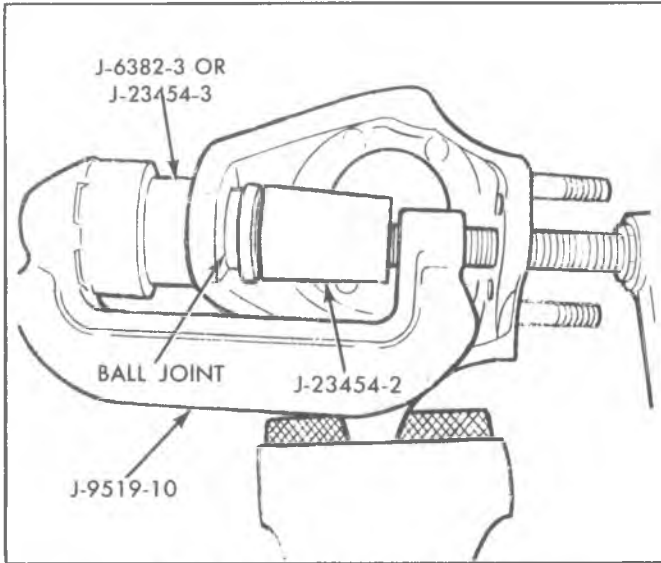

Fig. 3C-13K--Installing Lower Ball Joint

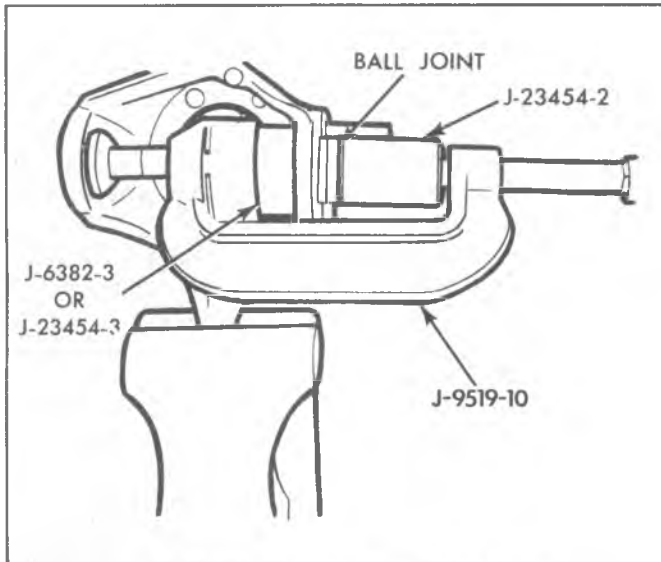

Fig. 3C-14K--Installing Upper Ball Joint

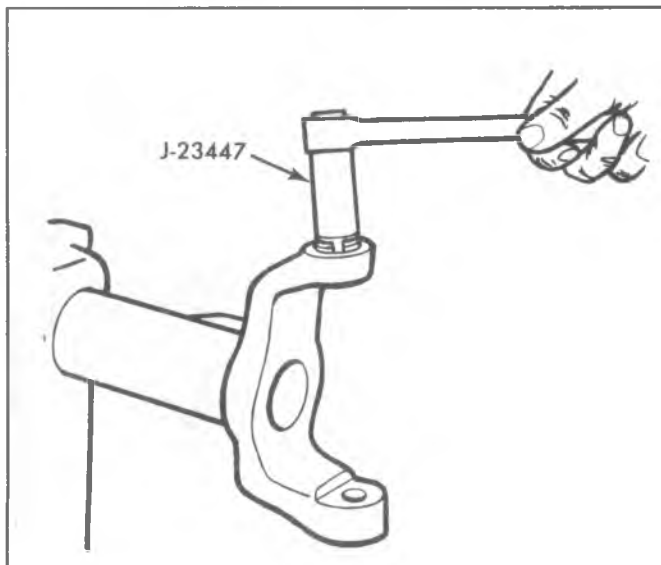

Fig. 3C-15K--Ball Stud Adjusting Sleeve

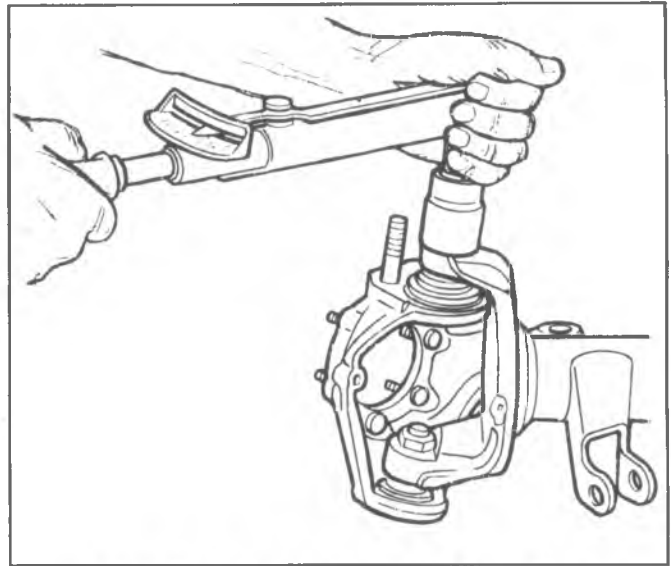

Fig. 3C-16K--Torquing Upper Ball Socket Nut

4. Install the upper ball joint into the knuckle. Press the stud into the knuckle until properly seated using Tools J-9519-10, J-23454-2, and J-23454-4 or equivalent as shown in Figure 3C-14K.

#### Installation

**NOTICE:** See NOTICE on page 1 of this section regarding the fasteners in the following steps.

1. Position the knuckle and sockets to the yoke. Install new nuts finger tight to the upper (the nut with the cotter pin slot) and lower ball socket studs.
2. Push up on the knuckle (to keep the ball socket from turning in the knuckle) while tightening the lower socket retaining nut. PARTIALLY torque lower nut to 40 N·m (30 ft. lbs.)
3. Torque the yoke upper ball stud adjusting sleeve to 70 N·m (50 ft. lbs.) using Spanner J-23447. See Figure 3C-15K.

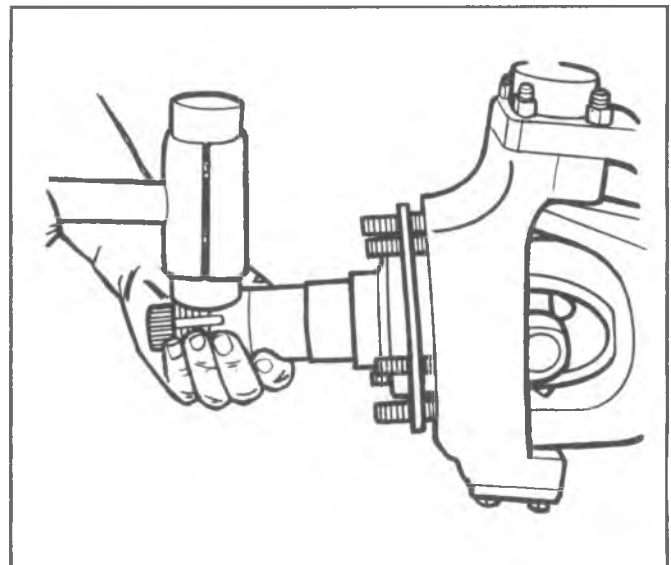

Fig. 3C-17K--Removing Spindle



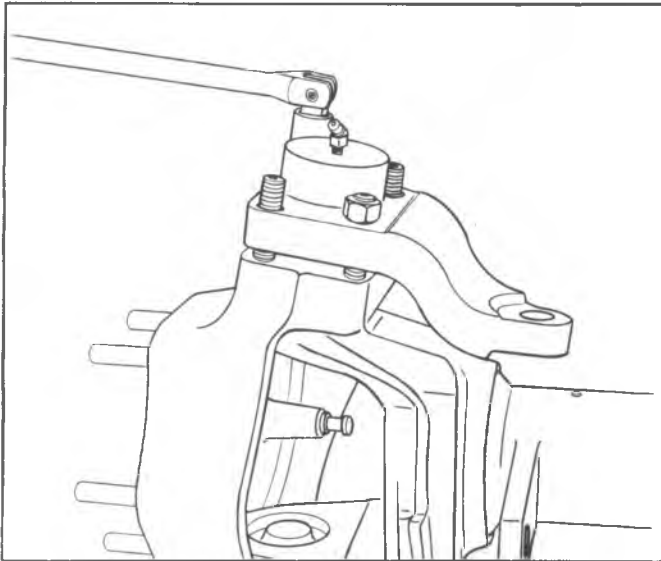

Fig. 3C-18K--Removing Nuts Alternately

4. Torque the upper ball socket nut to 100 ft. lbs. as shown in Figure 3C-16K. After torquing the nut, do not loosen to install cotter pin, apply additional torque, if necessary, to line up hole in stud with slot in nut.
5. Apply FINAL torque to lower nut, 95 N·m (70 ft. lbs.).
6. If the tie rod and steering arm were removed:
  - a. Assemble the steering arm using the three stud adapters and three new self-locking nuts. Torque the nuts to 120 N·m (90 ft. lbs.).
  - b. Assemble the tie rod to the knuckle arm. Torque the tie rod nuts to 60 N·m (45 ft. lbs.) and install cotter pin.

### KNUCKLE - K30 (WITH KING PINS)

#### Removal

1. Remove the hub and spindle as outlined earlier. If necessary, tap lightly with a rawhide hammer to free it from the knuckle. Check bronze spacer located

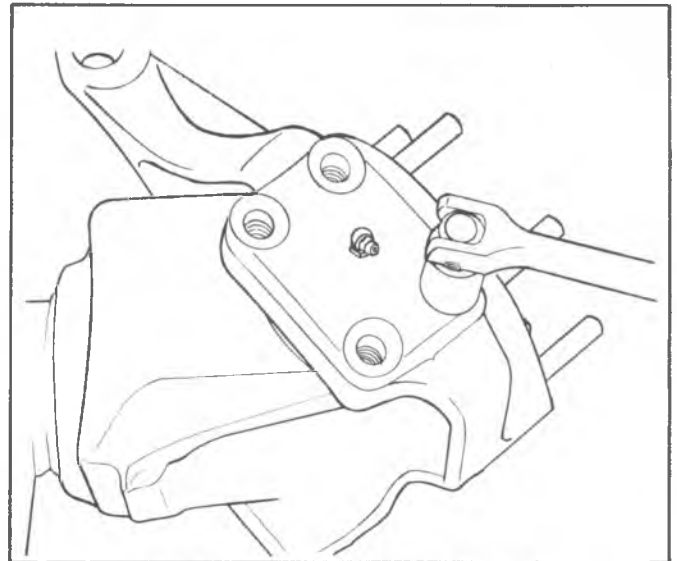

Fig. 3C-20K--Removing Lower Bearing Cap

- between axle shaft joint assembly and bearing. If wear is evident, replace with a new one. See Figure 3C-17K.
2. Remove four nuts from upper king pin cap. Remove nuts alternately as compression spring will force cap up. Refer to Figure 3C-18K.
3. Remove cap, compression spring, and gasket, as shown in Figure 3C-19K. Discard gasket, replace with new one at time of assembly.
4. From the underside of the knuckle, remove four cap screws from the lower king pin bearing cap. Remove the bearing cap-and-lower king pin. See Figure 3C-20K.
5. Remove upper king pin tapered bushing and knuckle from yoke. Remove king-pin felt seal. See Figure 3C-21K. Remove knuckle.
6. Remove upper king-pin from yoke with large breaker bar and J-26871, as seen in Figure 3C-22K.  
Torque specification is 677-813 N·m (500-600 ft. lbs.).

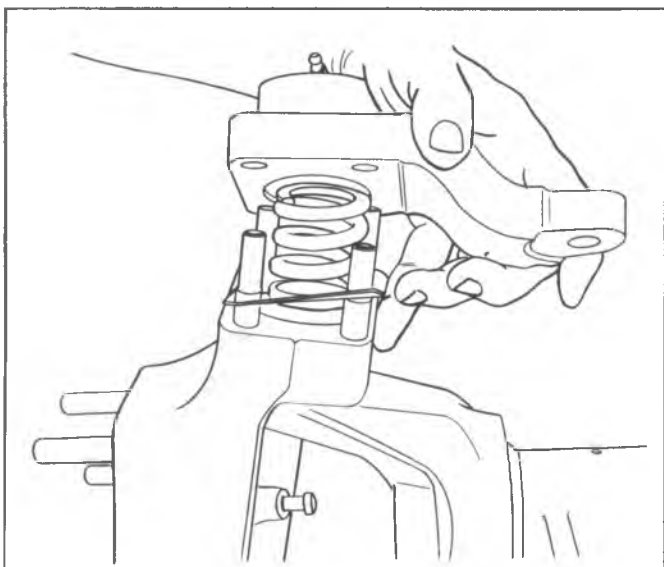

Fig. 3C-19K--Removing Cap, Spring and Gasket

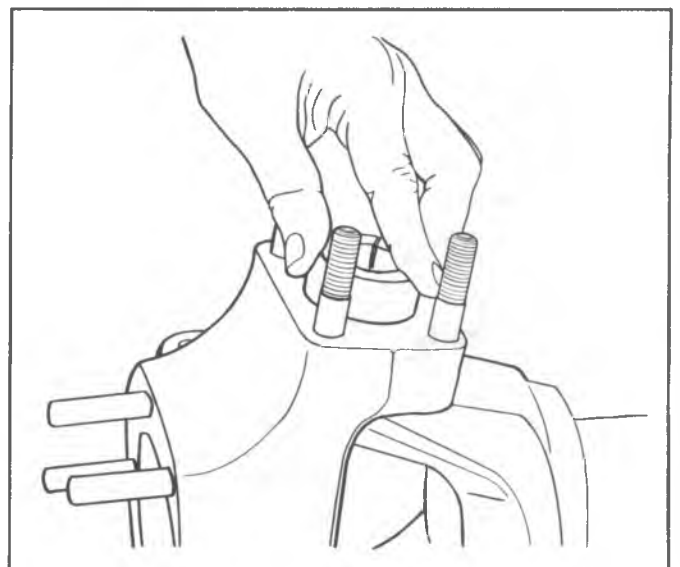

Fig. 3C-21K--Removing Tapered Bushing

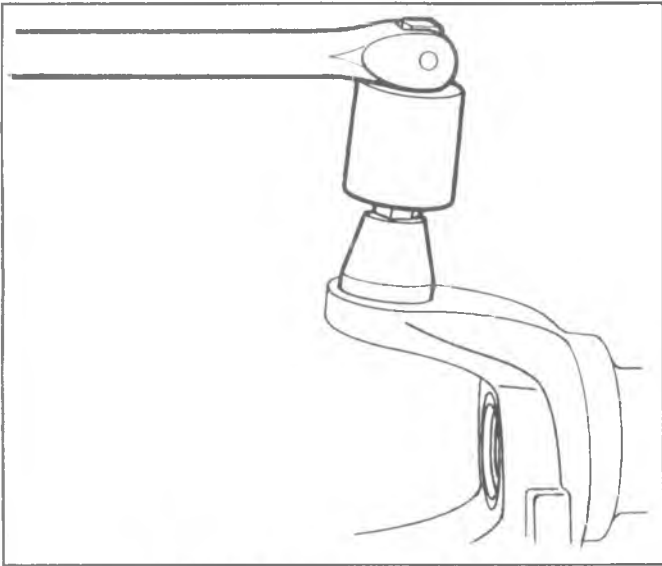

Fig. 3C-22K--Removing Upper King Pin

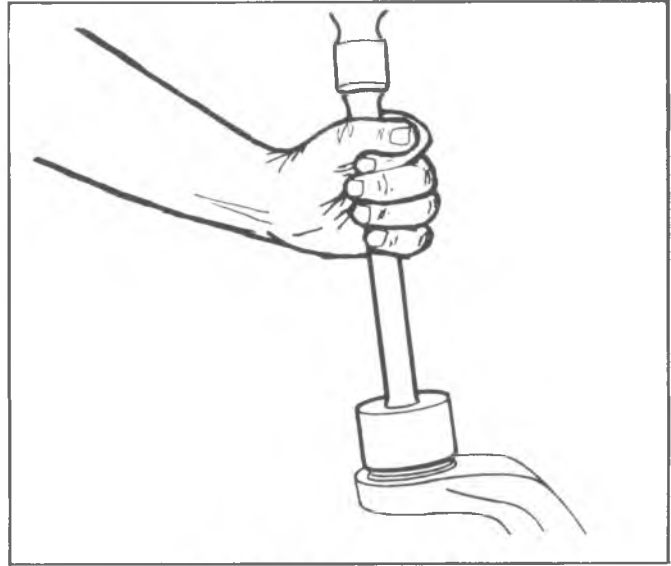

Fig. 3C-25K--Installing Oil Seal

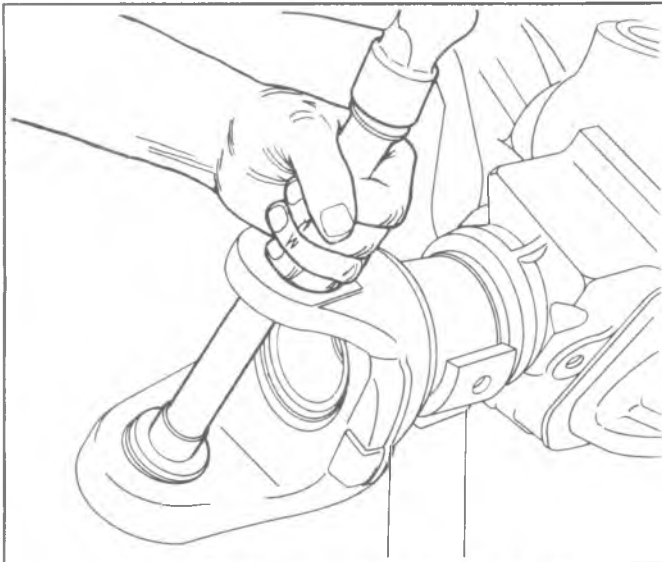

Fig. 3C-23K--Removing Cup, Cone and Seal

7. Remove lower king pin bearing cup, cone, grease retainer, and seal all at the same time, as shown in Figure 3C-23K. Discard seal and replace with new one at time of assembly. If grease retainer is damaged, replace with new one at time of assembly.

#### Installation

**NOTICE:** See the NOTICE on page 1 of this section regarding the fasteners in the following steps.

1. Assemble new grease retainer and lower king pin bearing cup, using J-7817, as shown in Figure 3C-24K.
2. Fill the area in grease retainer with specified grease, then grease the bearing cone and install. Install new lower king pin bearing oil seal, using J-22281, as shown in Figure 3C-25K.

Do not distort oil seal. It will protrude slightly from the surface of yoke flange when fully installed.

3. Install upper king-pin, using J-28871 as shown in Figure 3C-26K. Torque to 677.50-813.00 N·m (500-600 ft. lbs.).

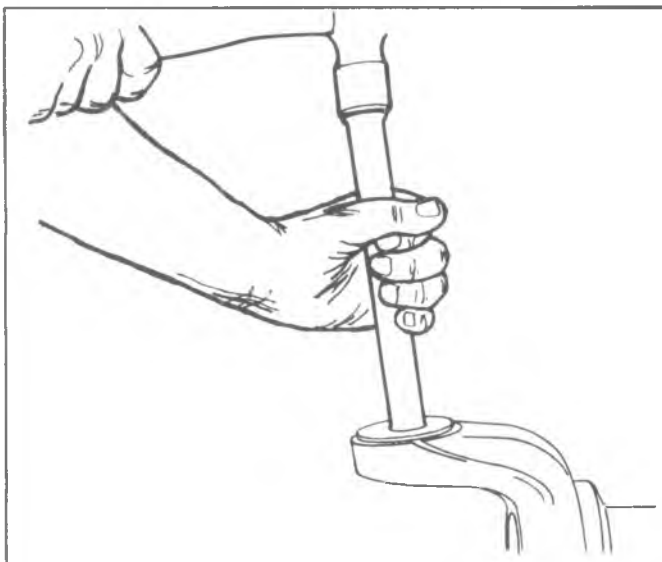

Fig. 3C-24K--Installing Grease Retainer

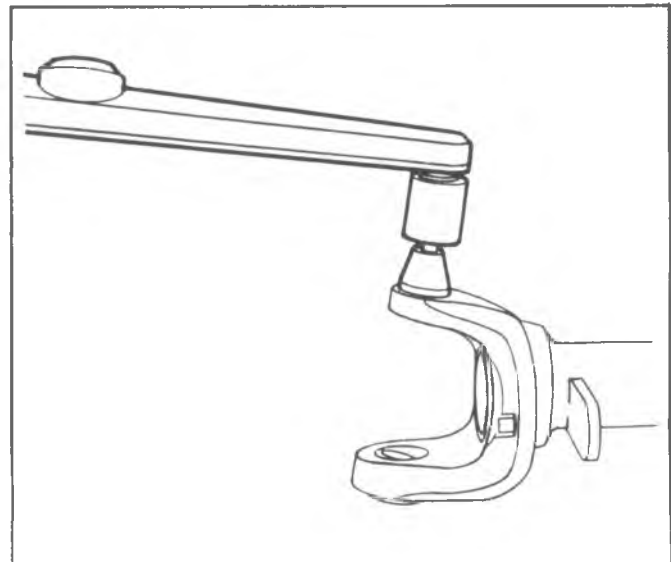

Fig. 3C-26K--Installing Upper King-Pin

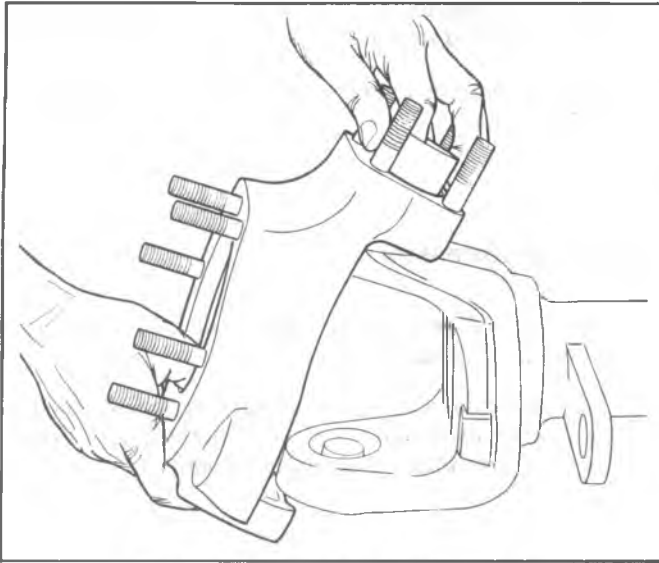

Fig. 3C-27K--Installing Knuckle to Yoke

4. Assemble felt seal to king pin, assemble knuckle, assemble tapered bushing over king pin, as shown in Figure 3C-27K.
5. Assemble lower bearing cap-and-king pin with four cap screws. Tighten cap screws alternately and evenly; see Figure 3C-28K. Torque cap screws to 95-120 N·m (70-90 ft. lbs.).
6. Assemble compression spring on upper king pin bushing. Assemble bearing cap, with new gasket, over four studs. Tighten nuts alternately and evenly. Torque nuts to 95-120 N·m (70-90 lb. ft.) See Figure 3C-29K.

## SHOCK ABSORBER

### Removal (Fig. 3C-30K)

1. Raise vehicle on hoist.
2. Remove nuts and eye bolts securing upper and lower shock absorber eyes.
3. Withdraw shock absorber and inspect rubber eye bushings. If defective, replace shock absorber

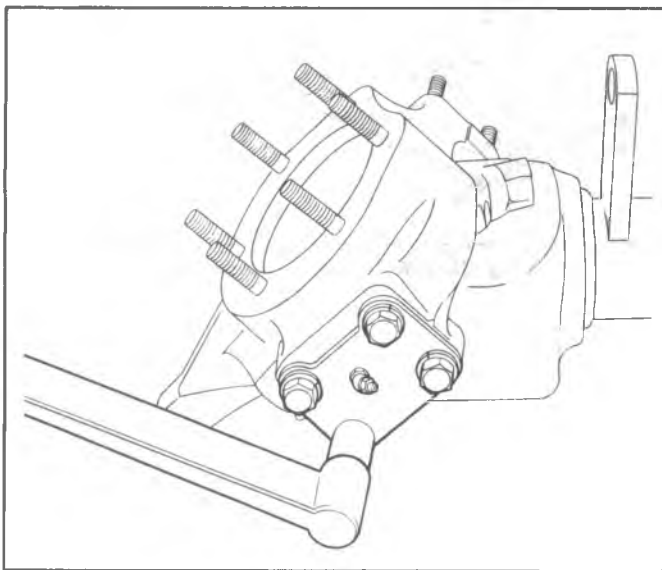

Fig. 3C-28K--Installing Lower Bearing Cap-and-King Pin

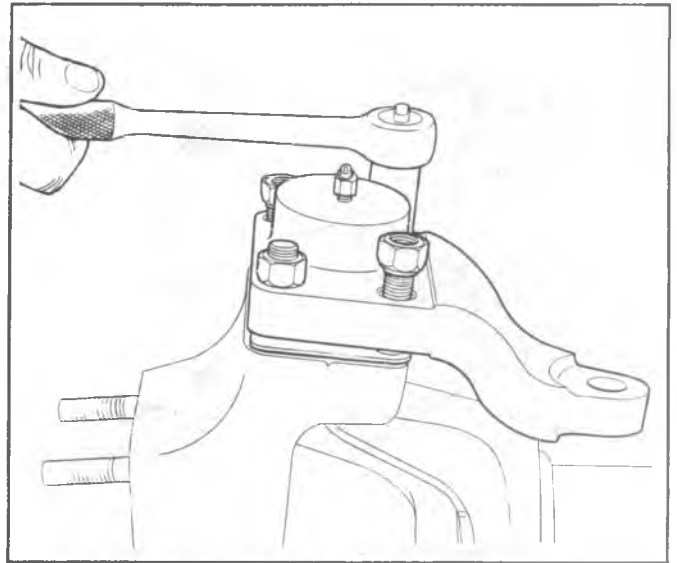

Fig. 3C-29K--Installing Bearing Cap/Steering Arm

assembly.

### Installation

Place shock absorber into position over mounting bolts or into mounting brackets. Install eye bolts and nuts and torque as shown in Specifications Section. Lower vehicle to floor.

## STABILIZER BAR-TYPICAL

### Removal (Fig. 3C-31K)

1. Raise vehicle on hoist and remove nuts and bolts attaching stabilizer brackets and bushings at frame location.
2. Remove brackets and bushings at lower spring anchor plates and remove stabilizer from vehicle.

### Inspection

Inspect rubber rushings for excessive wear or aging—replace where necessary. Use rubber lubricant when installing bushings over stabilizer bar.

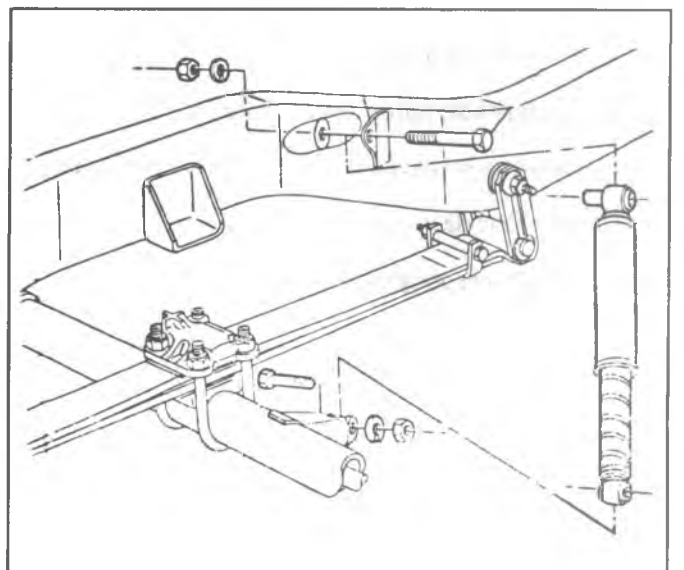

Fig. 3C-30K--Shock Absorber Attachment

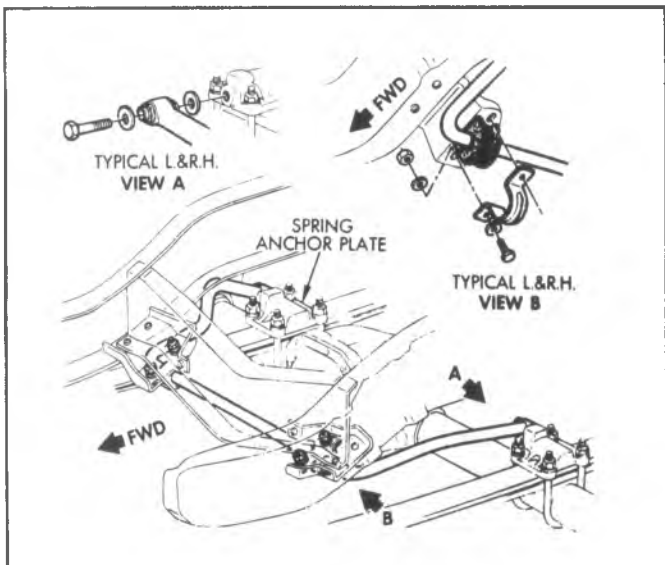

Fig. 3C-31K--Stabilizer Bar Attachment

#### Installation

**NOTICE:** See NOTICE on page 1 of this section regarding the fasteners referred to in step 2.

Slit in bar to frame bushings should be facing forward.

1. Place stabilizer in position on frame and install frame brackets over bushings. Install nuts and bolts loosely.
2. Install brackets over bushings at lower control arm location. Be sure brackets are positioned properly over bushings. Torque all nuts and bolts to specifications.
3. Lower vehicle to floor.

### LEAF SPRING AND BUSHINGS (Figs. 3C-32K and 3C-33K)

#### Removal

1. Raise vehicle on hoist.
2. Place adjustable lifting device under axle.
3. Position axle so that all tension is relieved from spring.
4. Remove shackle upper retaining bolt.
5. Remove front spring eye bolt.

6. Remove spring-to-axle u-bolt nuts and remove spring, lower plate and spring pads.
7. Remove shackle to spring bolt and remove bushings and shackle.

#### Bushing Replacement

1. Place spring on press and press out bushing using a suitable rod, pipe, or tool.
2. Press in new bushing; assure that tool presses on steel outer shell of bushing. Install until bushing protrudes an equal amount on each side of spring.

#### Spring Inserts (Liners) or Leaf Replacement

1. Place spring in vise and remove clips.
2. Remove center bolt. Open vise slowly, allowing spring to expand.
3. Wire brush, clean, and inspect for broken leaves.
4. Replace leaf or liners.

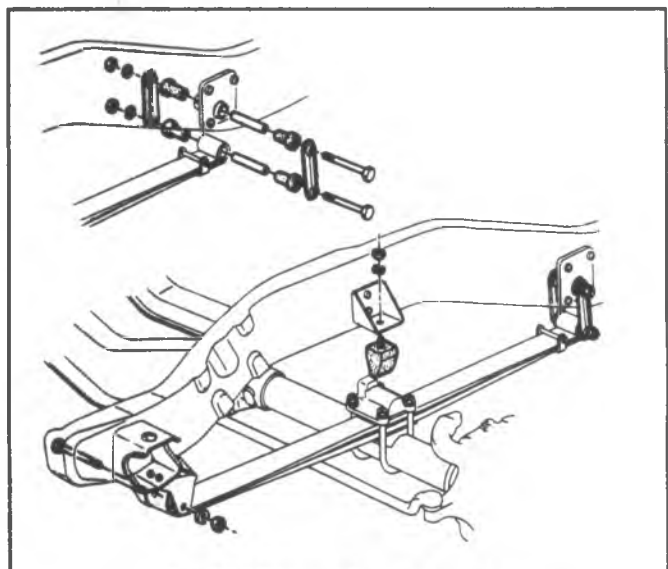

Fig. 3C-32K--Leaf Spring Assembly

**TIGHTENING SEQUENCE**

1. Install all four nuts to uniform engagement on 'U' Bolts to retain and position anchor plate in design position (perpendicular to axis of 'U' Bolts).
2. Torque nuts in positions 1 and 3 to 10-25 ft. lbs. (14-34 N·m).
3. Torque all nuts to full torque in following sequence: 2-4-1-3.

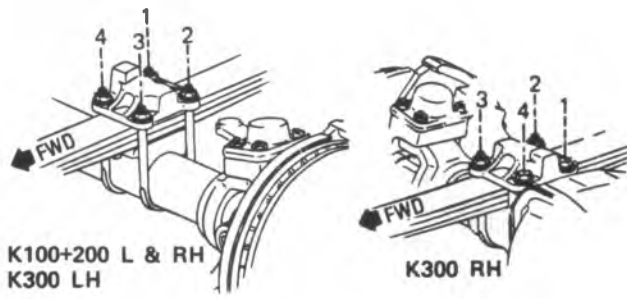

Fig. 3C-33K-U-Bolt Tightening Sequence

**Installation**

**NOTICE:** See NOTICE on page one of this section regarding the fasteners referred to in steps 5 and 6.

1. Install spring shackle bushings into spring and attach shackle. Do not tighten bolt.
2. Position spring upper cushion on spring.
3. Insert front of spring into frame and install bolt. Do not tighten.
4. Install shackle bushings into frame and attach rear shackle. Do not tighten bolt.
5. Install lower spring pad and spring retainer plate. Torque bolts to specifications, Fig. 3C-33K.
6. Torque front and rear spring eye and shackle bolts to specifications.
7. Remove stands and lower vehicle to floor.

## SPECIFICATIONS

### FRONT SUSPENSION BOLT TORQUE (ft. lbs.) \* †

|                                    | C -10        | CP-20-30            | K-All                 | G-10-20      | G-30                |
|------------------------------------|--------------|---------------------|-----------------------|--------------|---------------------|
| Lower Control Arm Shaft U-Bolt     | 85           | 85                  | —                     | 65           | 85                  |
| Upper Control Arm Shaft Nuts       | 70           | 105                 | —                     | 70           | 105                 |
| Control Arm Rubber Bushings        | 115          | —                   | —                     | 115          | —                   |
| Upper Control Arm Bushing Steel †† |              | New 190<br>Used 115 | —                     | —            | New 190<br>Used 115 |
| Lower Control Arm Bushing Steel †† |              | New 280<br>Used 130 | —                     | —            | New 280<br>Used 130 |
| Upper Ball Joint Nut               | * 50         | **90                | **100                 | * 50         | **90                |
| Lower Ball Joint Nut               | **90         | **90                | ***80                 | **90         | **90                |
| Nut, Spindle-to-Knuckle            | —            | —                   | 65                    | —            | —                   |
| Crossmember to Side Rail •         | 65           | 65                  | —                     | 65           | 65                  |
| Crossmember to Bottom Rail ••      | 90           | 90                  | —                     | 90           | 90                  |
| Crossmember Brake Support Struts   | 60           | 60                  | —                     | 60           | 60                  |
| Stabilizer Bar to Control Arm      | 25           | 25                  | Anchor<br>Plate —130  | 25           | 25                  |
| Stabilizer Bar to Frame            | 25           | 25                  | .55                   | 25           | 25                  |
| Shock Absorber Upper End           | 140          | 140                 | 65                    | 75           | 75                  |
| Shock Absorber Lower End           | 60           | 60                  | 65                    | 75           | 75                  |
| Brake Splash Shield to Knuckle     | 120 in. lbs. | 120 in. lbs.        | 120 in. lbs.          | 120 in. lbs. | 120 in. lbs.        |
| Wheel Bearing Adjustment           | —            | —                   | Inner 35<br>Outer ••• | —            | —                   |
| Wheel Bearing End Movement         | .001-.005"   | .001-.005"          | .001-.010"            | .001-.005"   | .001-.005"          |
| Caliper Mounting Bolt              | 35           | 35                  | —                     | 35           | 35                  |
| Spring — Front Eye Bolt            | —            | —                   | 90                    | —            | —                   |
| Spring — Rear Eye Bolt             | —            | —                   | 50                    | —            | —                   |
| Spring — To Rear Shackle Bolt      | —            | —                   | 50                    | —            | —                   |
| Spring — To Axle U-Bolt            | —            | —                   | 150                   | —            | —                   |
| Spring — Front Support to Frame    | —            | —                   | 25                    | —            | —                   |
| Suspension Bumper                  | 15           | 15                  | 25                    | 15           | 15                  |
| Stabilizer to Spring Plate         | —            | —                   | 130                   | —            | —                   |

\* Plus additional torque to align cotter pin. Not to exceed 90 ft. lbs. maximum.

\*\* Plus additional torque to align cotter pin. Not to exceed 130 ft. lbs. maximum.

\*\*\* Plus additional torque to align cotter pin.

† All specifications are given in foot pounds of Torque unless indicated otherwise.

†† C10, G10-20 Rubber Bushings; C20-30, P10-30 Steel Bushings.

• P300 (32), P300 (42) and JF9 — 100 ft. lbs.

•• P300 (32) — 215 ft. lbs., P300 (42) and JF9 — 130 ft. lbs.

••• (K10-20) 205 ft. lbs., (K30) 65 ft. lbs.

# SPECIAL TOOLS

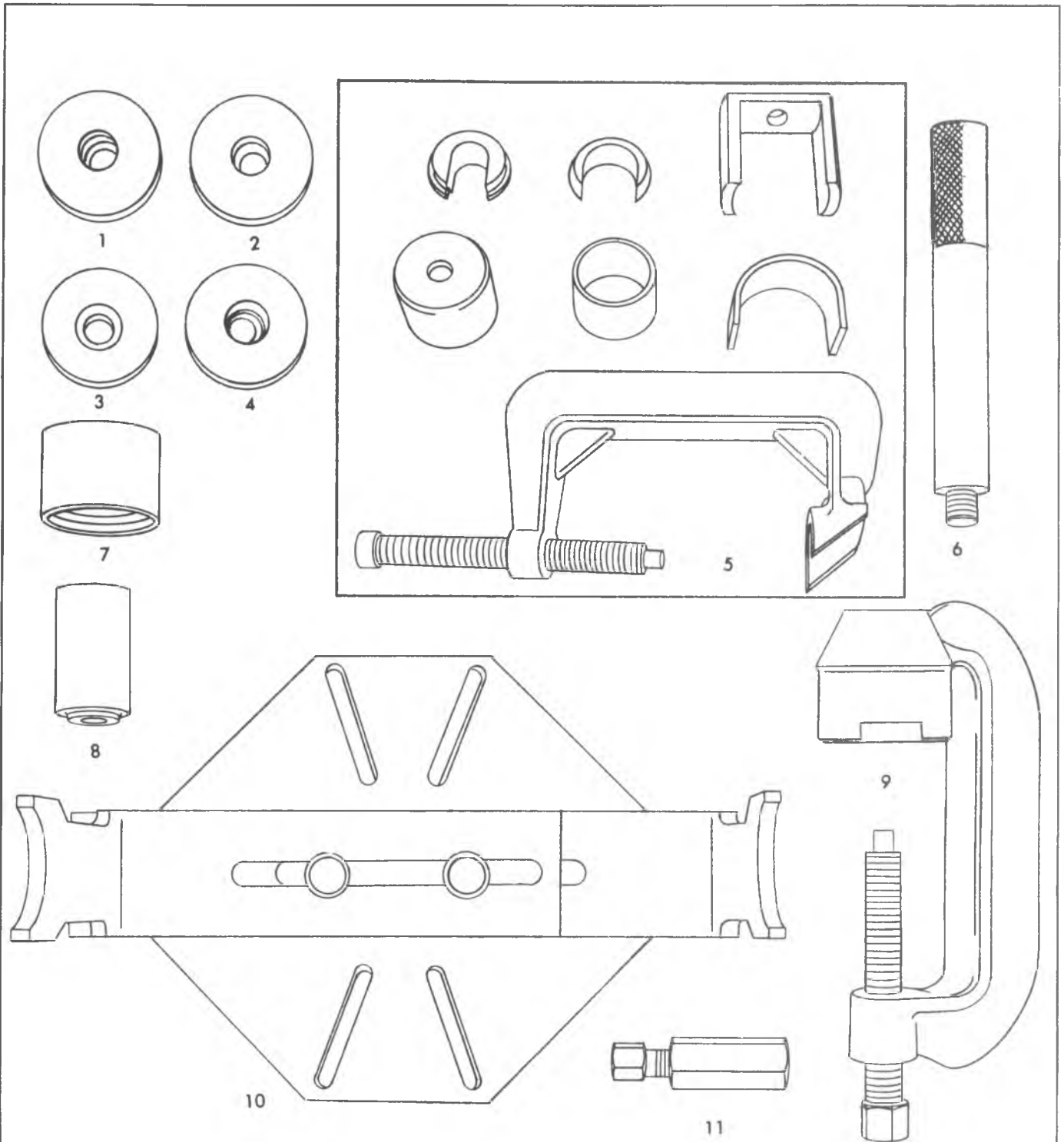

- |    |           |                        |     |            |                      |
|----|-----------|------------------------|-----|------------|----------------------|
| 1. | J-8457    | Bearing Race Installer | 6.  | J-8092     | Driver Handle        |
| 2. | J-8458    | Bearing Race Installer | 7.  | J-9519-9   | Ball Joint Installer |
| 3. | J-8849    | Bearing Race Installer | 8.  | J-9519-7   | Ball Joint Remover   |
| 4. | J-9276-2  | Bearing Race Installer | 9.  | J-9519-10  | "C" Clamp            |
| 5. | J-24435-1 | Bushing Replacement    | 10. | J-23028-01 | Spring Remover       |
|    | thru 7    | C 10, G 10-20          | 11. | J-23742-1  | Ball Joint Remover   |

Fig. 3C-ST--Special Tools

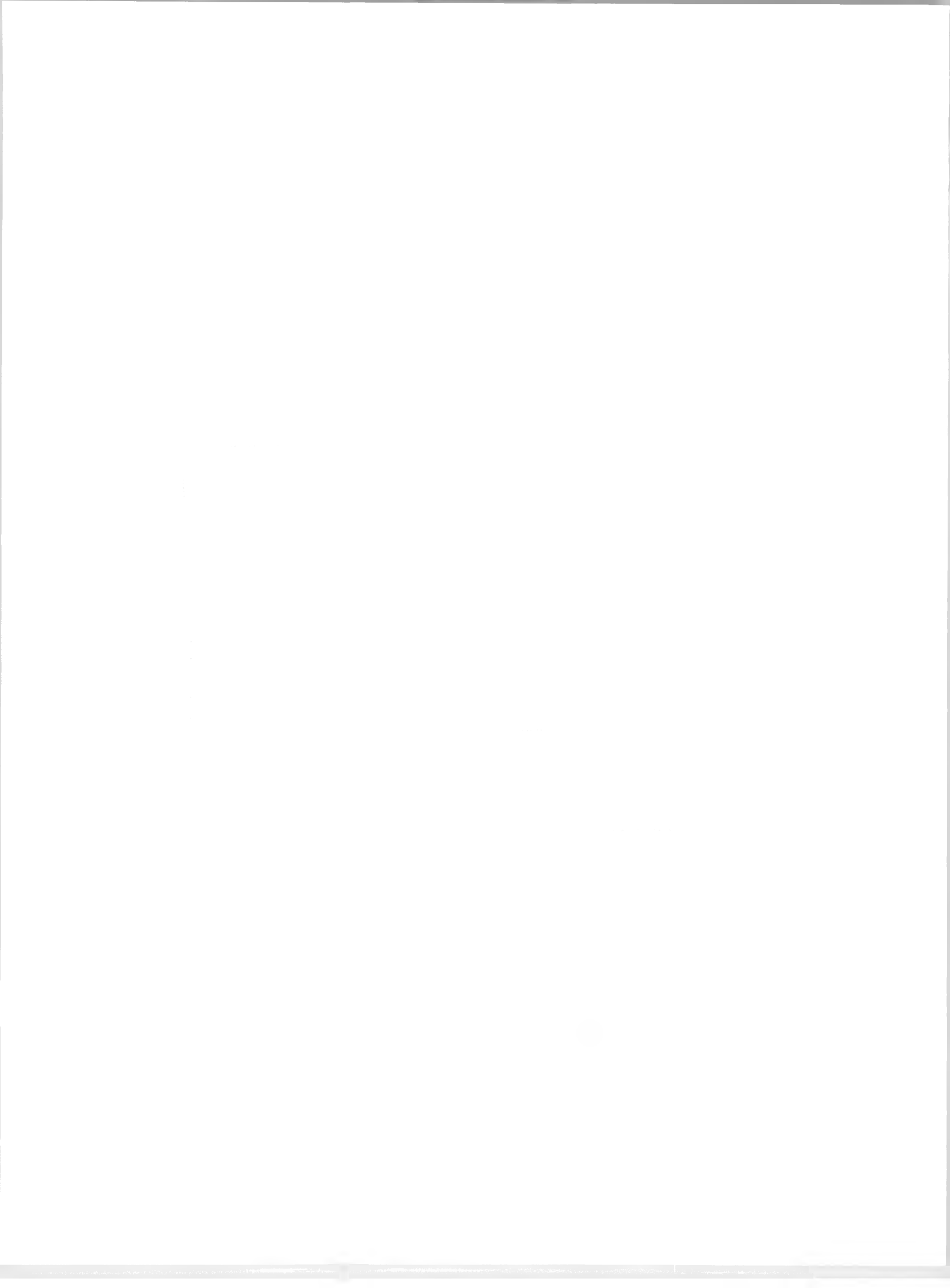



## SECTION 3D

# REAR SUSPENSION

The following notice applies to one or more steps in the assembly procedure of components in this portion of the manual as indicated at the appropriate locations by the terminology "See Notice on page 1 of this Section".

**NOTICE** This fastener is an important attaching part in that it could affect the performance of vital components and systems, and/or could result in major repair expense. It must be replaced with one of the same part number or with an equivalent part if replacement becomes necessary. Do not use a replacement part of lesser quality or substitute design. Torque values must be used as specified during reassembly to assure proper retention of this part.

### INDEX

|                                   |       |
|-----------------------------------|-------|
| General Description .....         | 3D-1  |
| Component Parts Replacement ..... | 3D-2  |
| Shock Absorbers.....              | 3D-2  |
| Stabilizer Shaft .....            | 3D-3  |
| Leaf Spring Assembly.....         | 3D-4  |
| Specifications .....              | 3D-10 |

## GENERAL DESCRIPTION

All 10-30 series vehicles use a leaf spring/solid rear axle suspension system. Typical systems are illustrated in Fig. 3D-1, 3D-2 and 3D-3.

The rear axle assembly is attached to multi-leaf springs by "U" bolts. The spring front eyes are attached to the frame at the front hangers, through rubber bushings. The rear ends of the springs are attached to the frame by the use of shackles which allow the spring to "change its length" while the vehicle is in motion. Control arms are not required with leaf springs.

Ride control is provided by two identical direct double acting shock absorbers angle-mounted between the frame and brackets attached to the axle tubes.

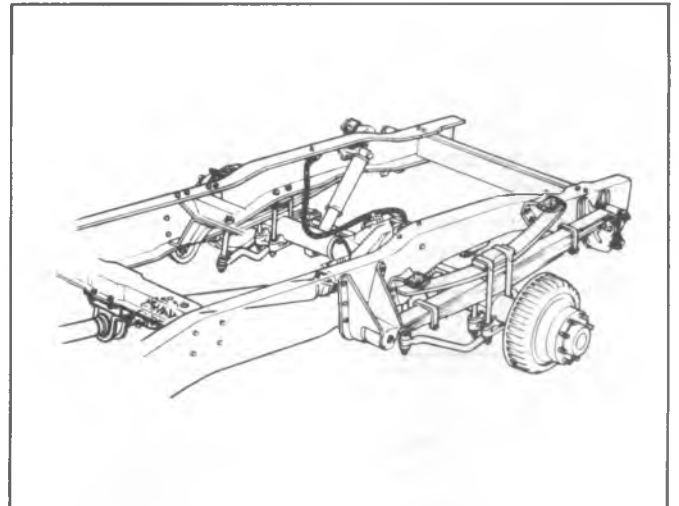

Fig. 3D-1--Typical C-30 H.D. Truck Rear Suspension

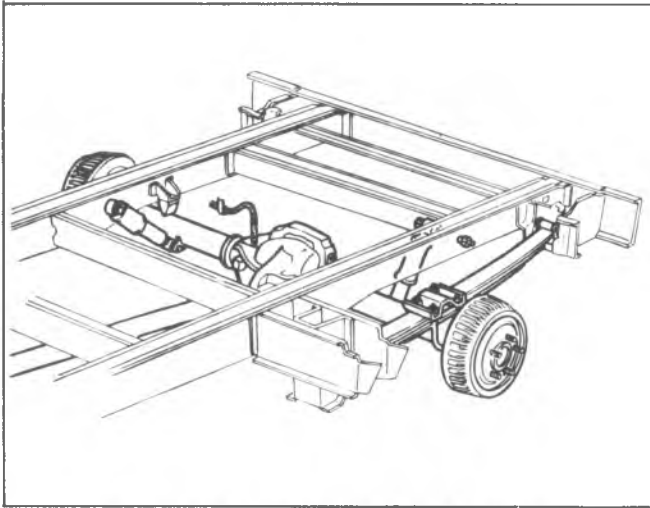

Fig. 3D-2--Typical G-Truck Rear Suspension

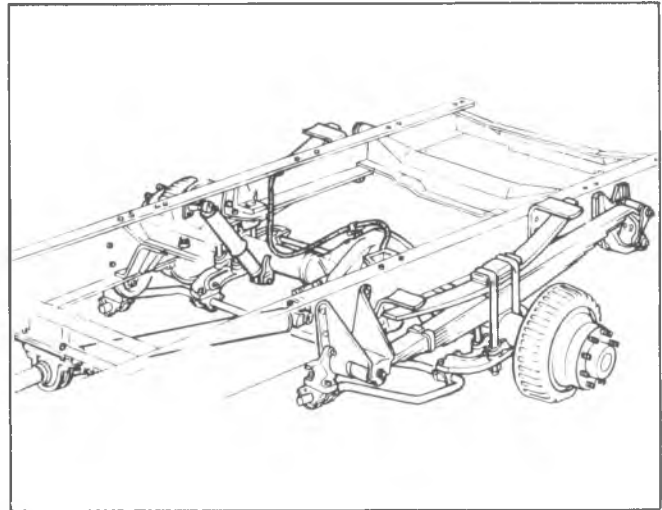

Fig. 3D-3--Typical P-30 H.D. Truck Rear Suspension

## COMPONENT PARTS REPLACEMENT

### SHOCK ABSORBERS

#### Replacement

Refer to Figs. 3D-4 through 3D-8 for specific vehicle mounting provisions.

1. Raise vehicle on hoist, and support rear axle.
2. At the upper mounting location, disconnect shock absorber by removing nut and washers shown, and bolt on G-models.
3. At the lower mounting location, remove nut, washers and bolt as shown.
4. Remove shock absorbers from vehicle.

5. To install shock absorber, place into position and reattach at upper mounting location. Be sure to install nuts and washers as shown.

6. Align lower end of shock absorber with axle bracket, and install bolt, washers and nut, as shown.

7. Tighten nuts to specifications.

**NOTICE:** See NOTICE on page 1 of this section regarding shock absorber fasteners.

8. Lower vehicle and remove from hoist.

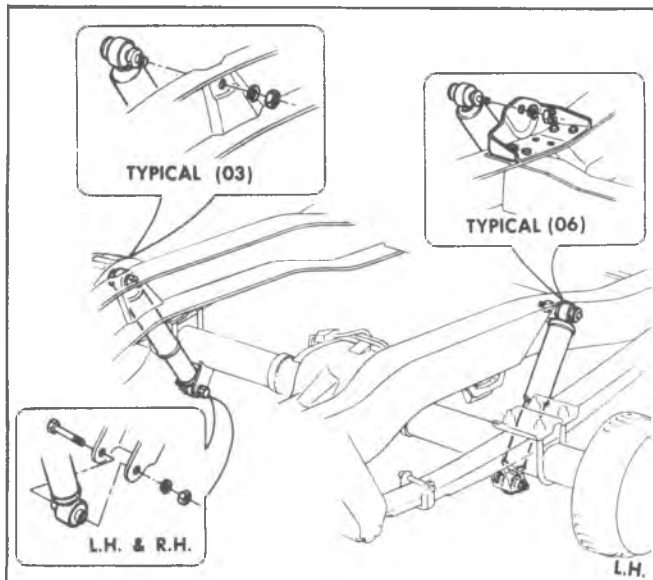

Fig. 3D-4--Shock Absorber-CK-10, CK-20 (03, 06)

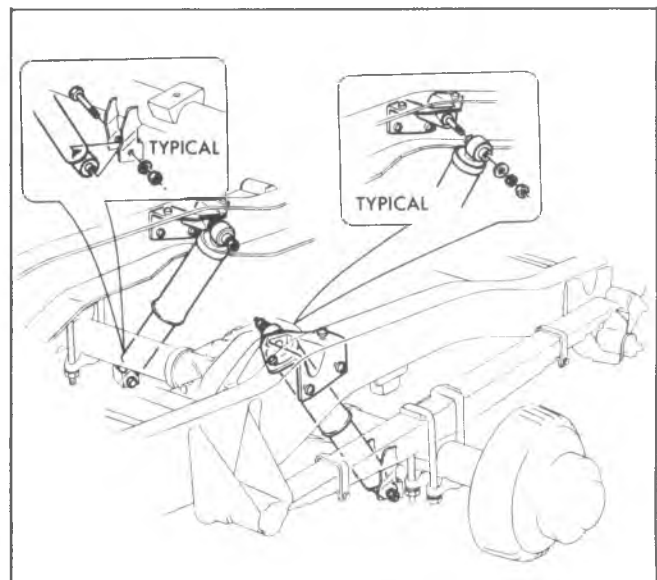

Fig. 3D-5--Shock Absorber-CK-20 (43), CK30

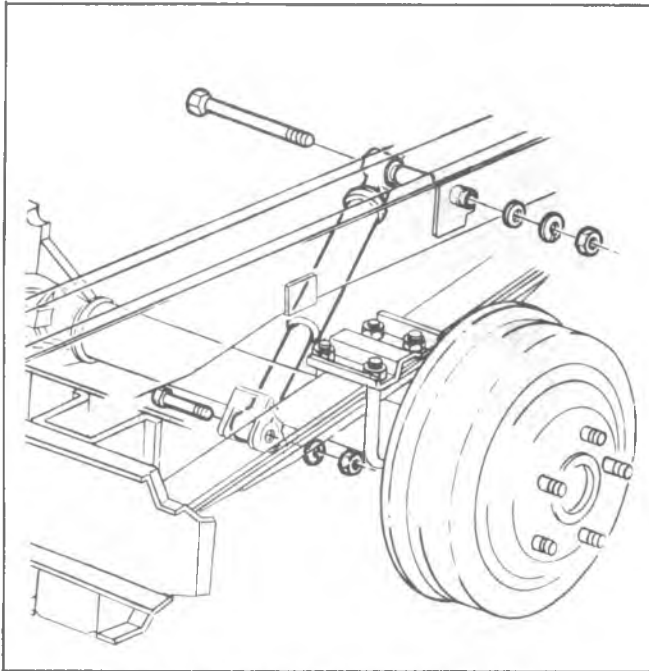

Fig. 3D-6--Shock Absorber-G-10, 20, 30

### STABILIZER SHAFTS

Refer to Fig. 3D-9, 3D-10 and 3D-11 for specific rear stabilizer shaft mounting on C and P models.

#### Replacement

1. Raise vehicle on hoist and support rear axle.
2. Remove nut, washer and grommet from link bolt at the frame side member on each side.
3. Withdraw link bolt, washers, grommets and spacer.

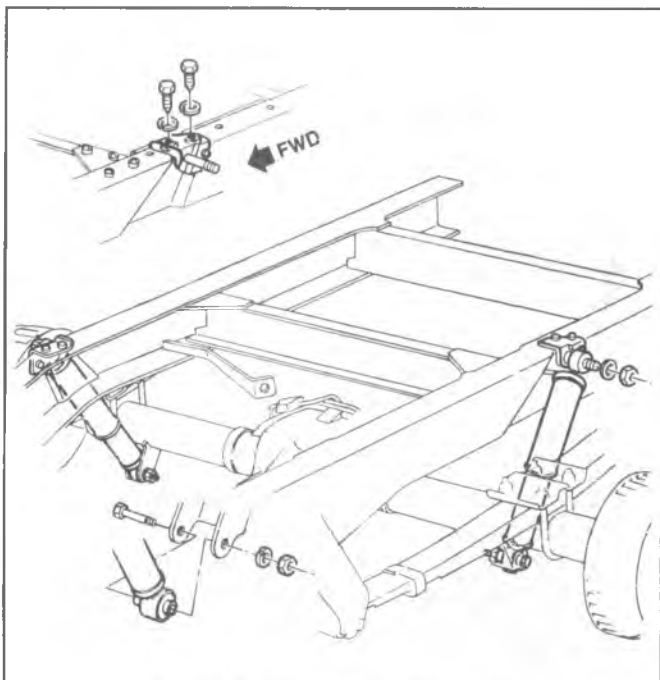

Fig. 3D-7--Shock Absorber-P-10, 20

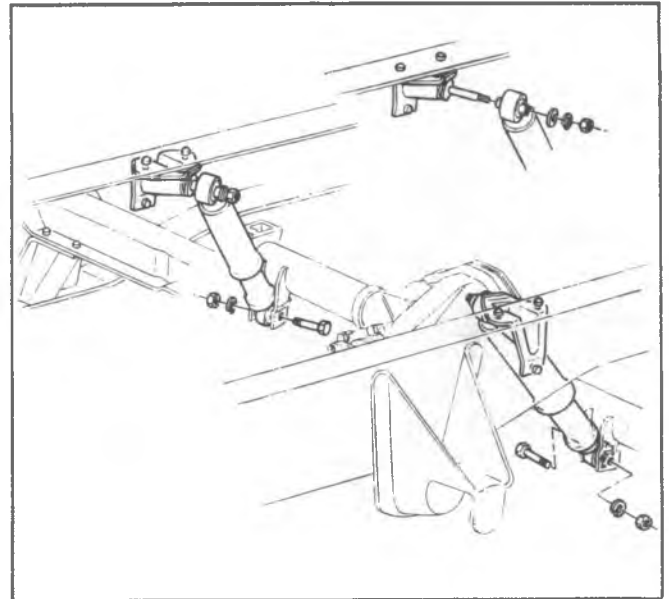

Fig. 3D-8--Shock Absorber-P30

4. Remove brackets from anchor plates by removing attaching screws.
5. Remove stabilizer shafts.
6. Reverse above steps to install stabilizer shaft. On installation, position shaft so parking brake cable is routed over stabilizer.
7. Torque all bolts to specifications.

**NOTICE:** See NOTICE on page 1 of this section, regarding stabilizer fasteners.

8. Lower hoist and remove vehicle.

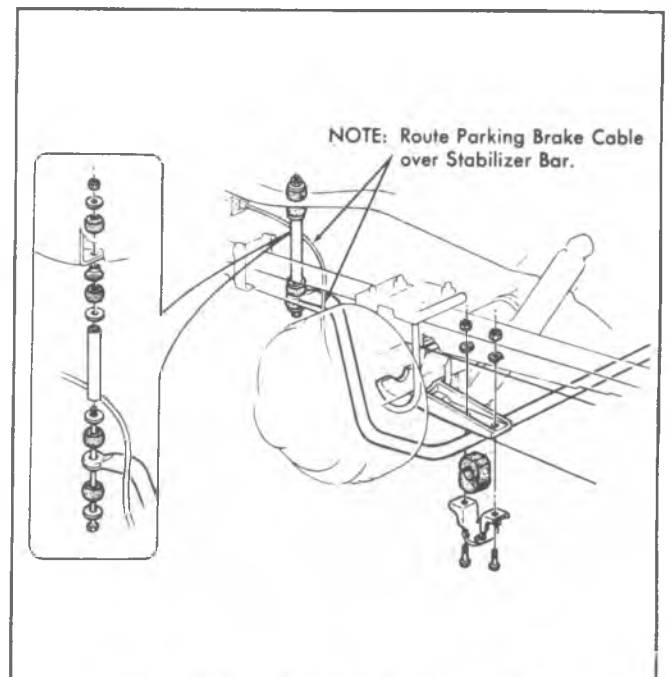

Fig. 3D-9--Rear Stabilizer Shaft-C-20(03)

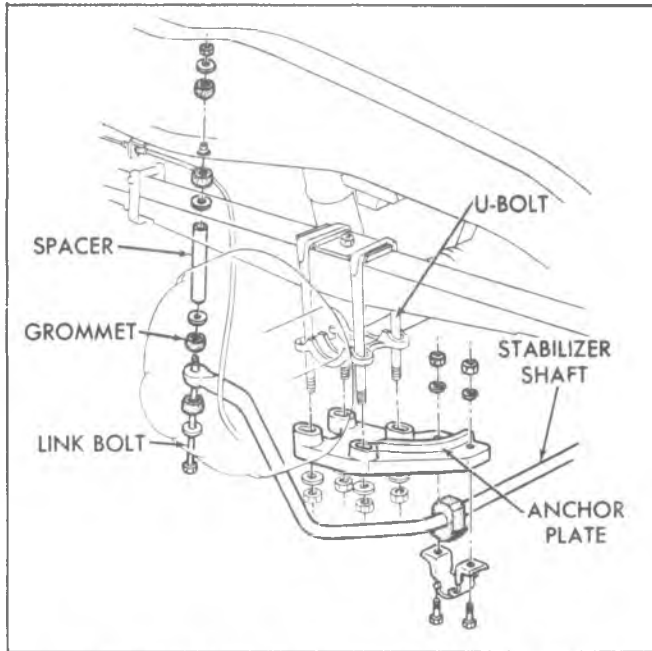

Fig. 3D-10--Rear Stabilizer Shaft-C-20(43), C-30

### LEAF SPRING ASSEMBLY

Refer to Figs. 3D-12 - 3D-21 for specific leaf spring mounting provisions of C, K, G and P models. Fig. 3D-22 illustrates a typical U-bolt anchor plate installation with the mandatory tightening sequence.

**NOTICE:** See NOTICE on page 1 of this section, regarding leaf spring fasteners.

#### Removal

1. Raise vehicle on hoist so that load in spring is relieved.
2. Loosen, but do not remove, spring-to-shackle retaining nut.
3. Remove nut and bolt securing shackle to spring hanger.
4. Remove nut and bolt securing spring to front hanger.
5. Remove "U" bolt retaining nuts, withdraw "U" bolts and spring plate from spring-to-axle housing attachment.
6. Withdraw spring from vehicle.
7. Inspect spring. Replace bushings, repair or replace spring unit as outlined in this section.

#### Bushing Replacement

1. Place spring on press and press out bushing using a suitable rod, pipe or tool.
2. Press in new bushing; assure that tool presses on steel outer shell of bushing.  
Rear Spring, Front Eye-Heavy Duty leaf springs on C20, CK30, and some P30 trucks use a staked-in-place flanged front eye bushing. Before this bushing is pressed out of the spring, the staked locations must be straightened with a chisel or drift. After a new bushing is installed, it must be staked in three equally spaced locations.

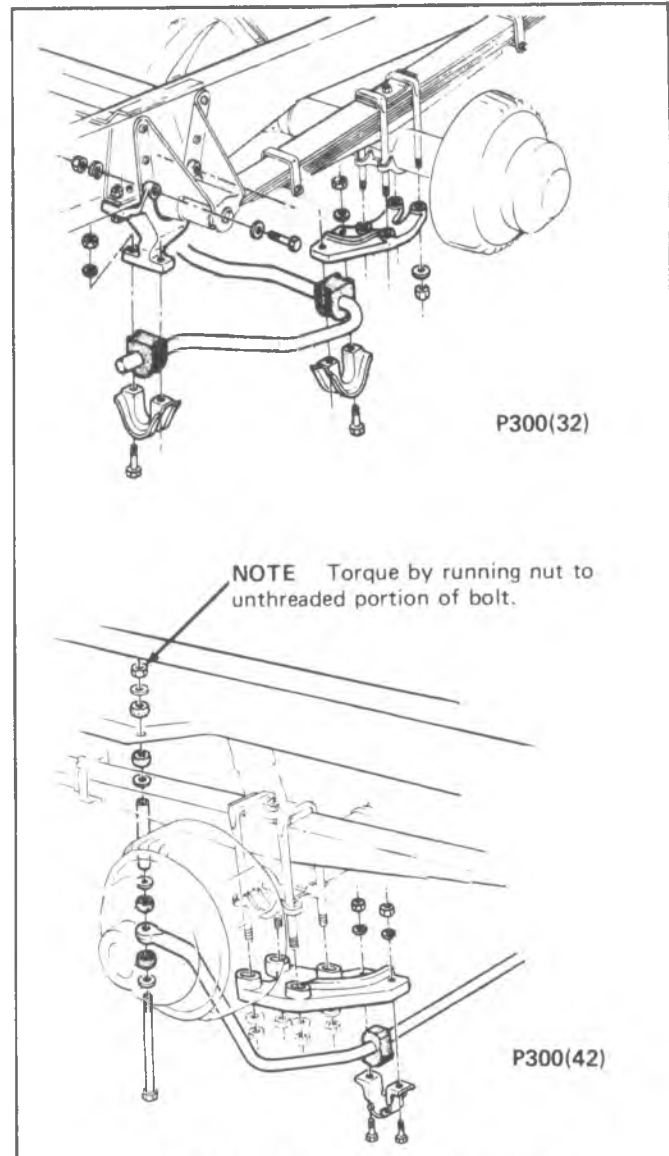

Fig. 3D-11--Rear Stabilizer Shaft-P30

#### Spring Leaf Replacement

1. Place spring assembly in a bench mounted vise and remove spring clips or pry clips open.
2. Position spring in vise jaws, compressing leaves at center and adjacent to center bolt.
3. File peened end of center bolt and remove nut. Open vise slowly to allow spring assembly to expand.
4. Wire brush and clean spring leaves. Inspect spring leaves to determine if replacement is required; also replace defective spring leaf liners at this time.
5. Align center holes in spring leaves by means of a long drift and compress spring leaves in a vise.
6. Remove drift from center hole and install a new center bolt. Tighten nut and peen bolt to retain nut.
7. Align spring leaves by tapping with hammer, then reinstall alignment clips. Spring clips should be bent sufficiently to maintain alignment, but not tight enough to bind spring action.

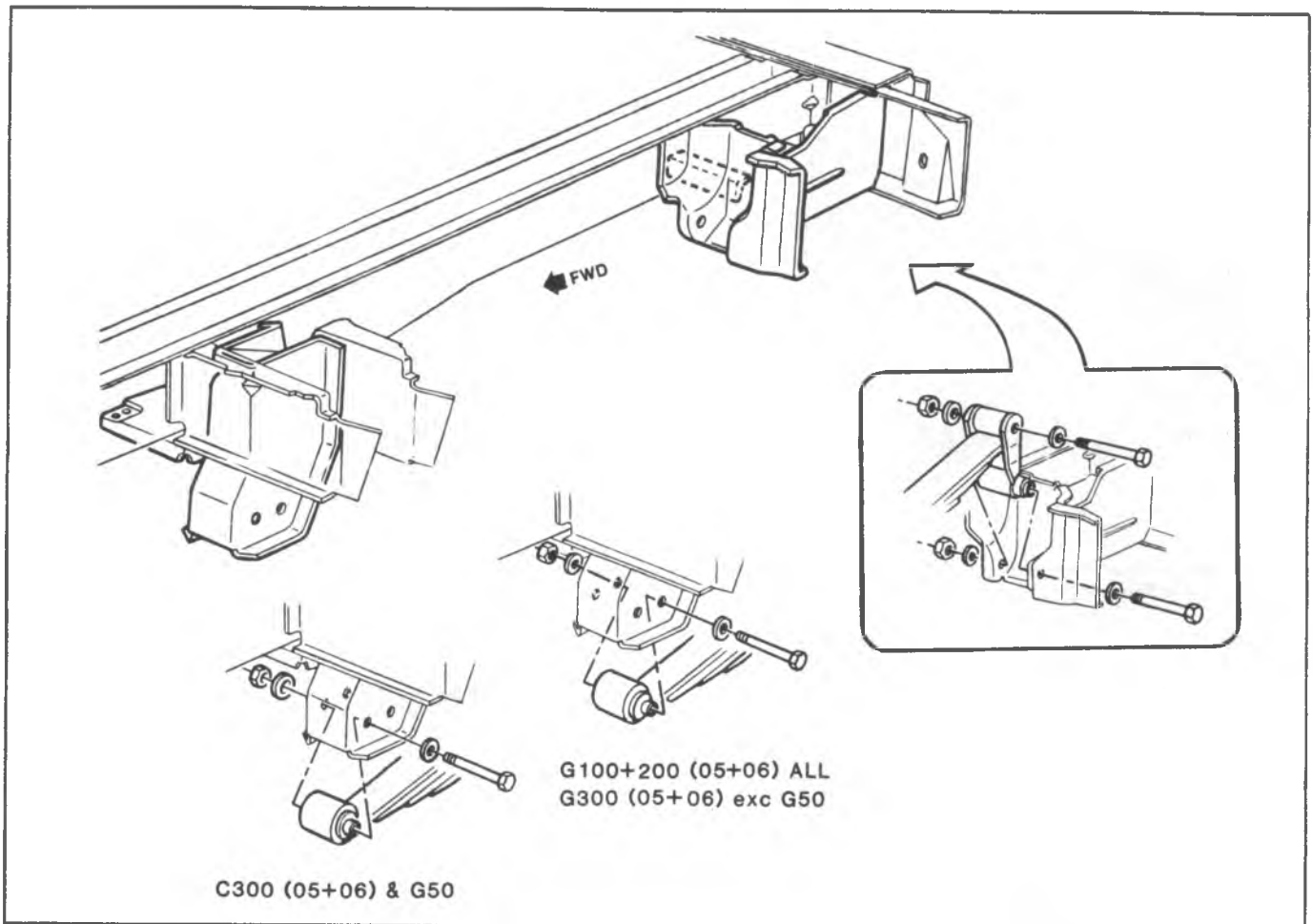

Fig. 3D-12--Rear Spring Hangers And Installation-G Models

**Leaf Spring Installation**

1. Clean axle spring pad and position spring assembly to axle. Position spring to insure clearance to hangers. The shackle assembly must be attached to the rear spring eye before installing shackle to rear hanger

shackle must be positioned with arrow pointing forward.

2. Install spring retainer plate and "U" bolts. Loosely install retaining nuts evenly, but do not torque at this time.

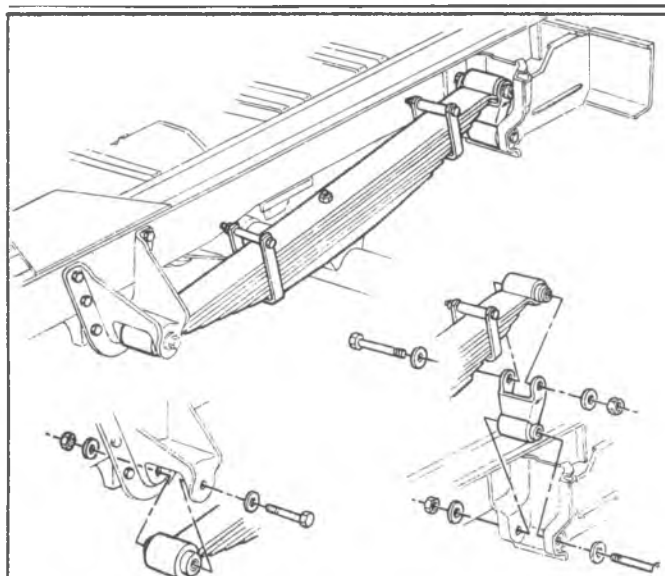

Fig. 3D-13--Rear Spring Installation - G Models (Cutaway Vans)

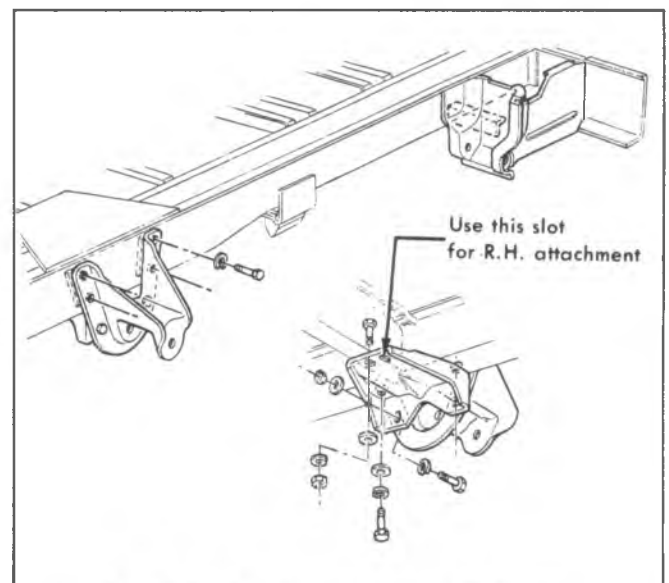

Fig. 3D-14--Rear Spring Hangers - G Models (Cutaway Vans)

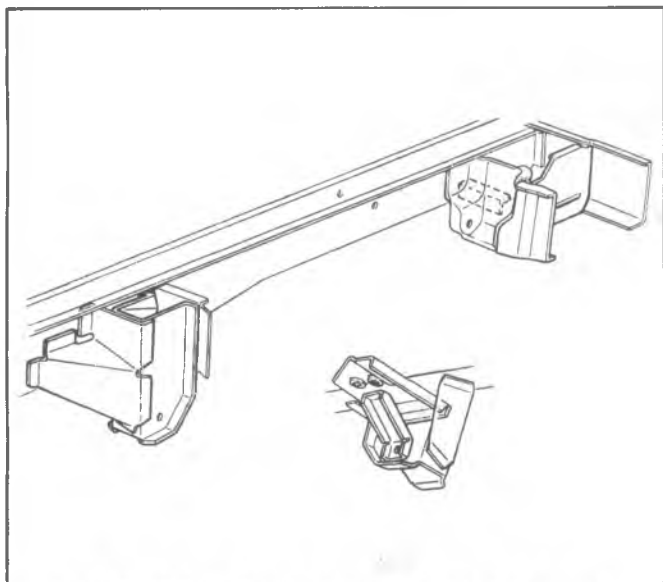

Fig. 3D-15--Rear Spring Hangers-G Models (Cutaway Vans)

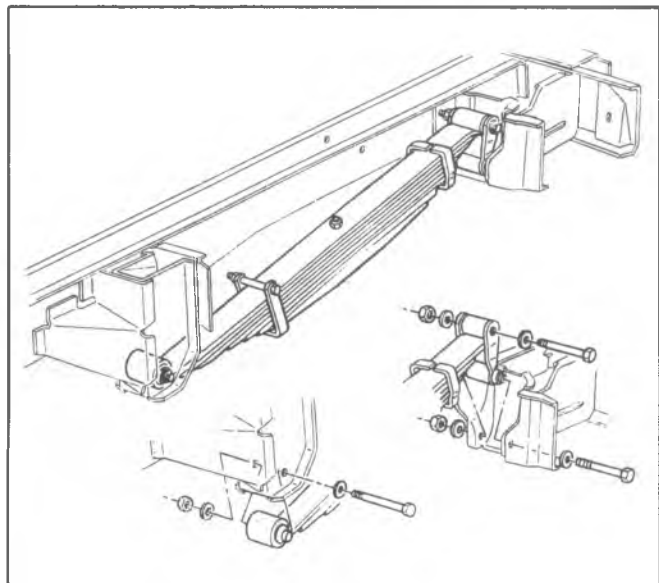

Fig. 3D-16--Rear Spring Installation - G Models (Cutaway Vans)

3. Jack frame as required to align spring and shackle with spring hangers.
4. Install shackle bolt and nut and again reposition spring, if necessary to align front eye. Install front eye bolt and nut. Torque hanger and shackle nuts to specifications. Make certain that the bolts are free-turning in their bushings prior to torquing.
5. Lower vehicle so that weight of vehicle is on suspension components and torque U-bolt nuts to specifications.
6. Lower vehicle and remove from hoist.

**U-Bolt and Anchor Plate Installation**

Fig. 3D-23 illustrates the mandatory sequence of tightening U-bolt nuts.

**NOTICE:** See NOTICE on page 1 of this section, regarding "U"-Bolt fasteners.

**SHACKLE REPLACEMENT**

1. Raise vehicle on hoist. Place adjustable lifting device under axle.
2. Remove load from spring by jacking frame.
3. Loosen spring-to-shackle retaining bolt, but do not remove.
4. Remove shackle-to-frame bracket retaining bolt then remove shackle bolt from spring eye.
5. Position shackle to spring eye and loosely install retaining bolt. Do not torque retaining bolt at this time.
6. Position shackle to frame bracket and install retaining bolt. Arrow stamped on shackle must point forward.
7. Rest vehicle weight on suspension components and torque both shackle bolt retaining nuts to specifications.

**NOTICE:** See NOTICE on page 1 of this section, regarding these fasteners.

8. Lower vehicle and remove from hoist.

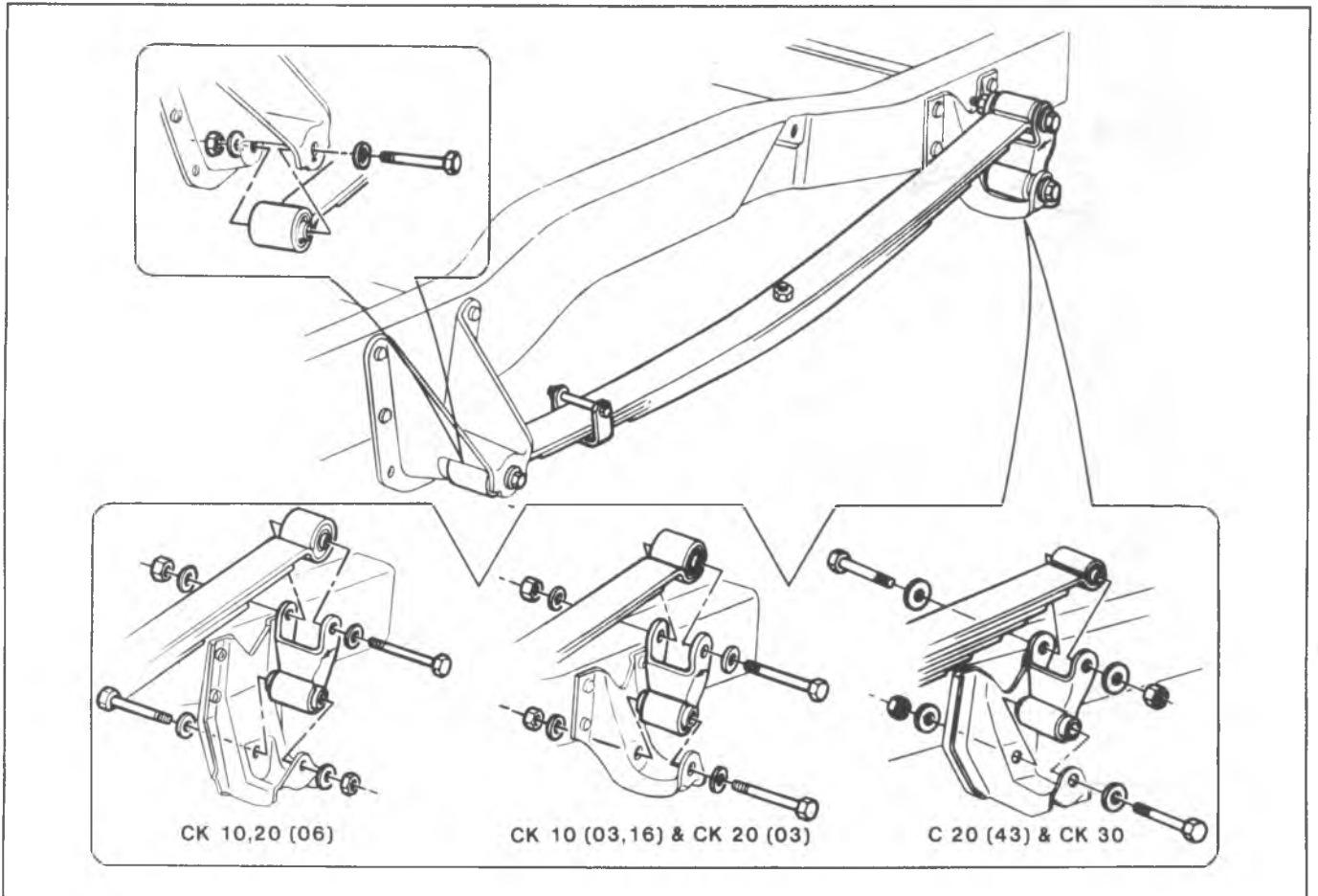

Fig. 3D-17--Rear Spring Installation-C-K Models

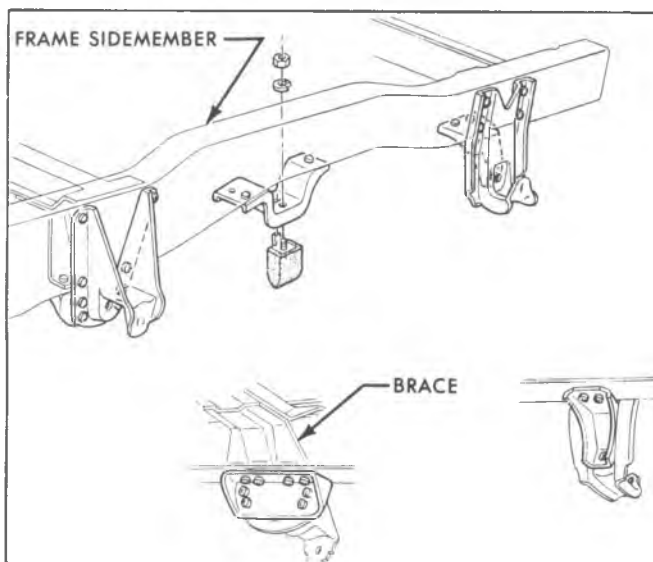

Fig. 3D-18--Rear Spring Hangers (K30)

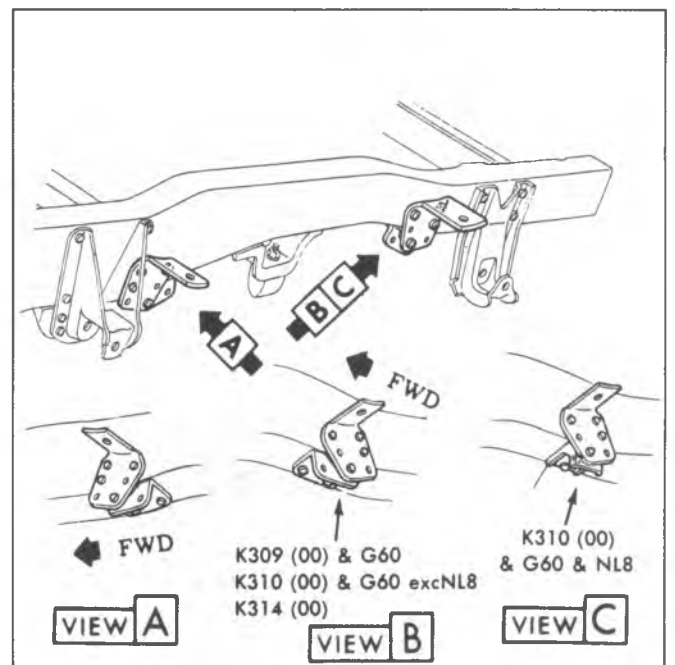

Fig. 3D-19--Auxiliary Spring Bracket (K30)

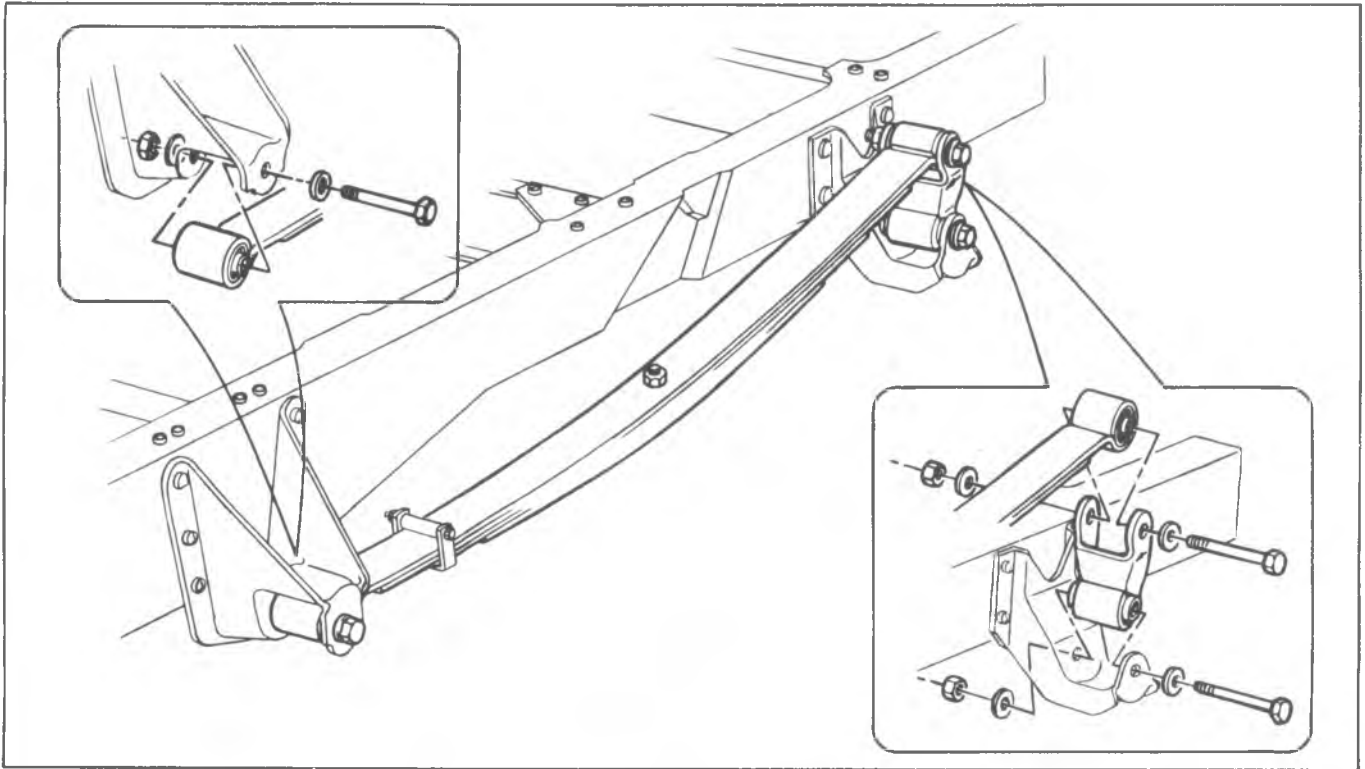

Fig. 3D-20--Rear Spring Installation-P10,20

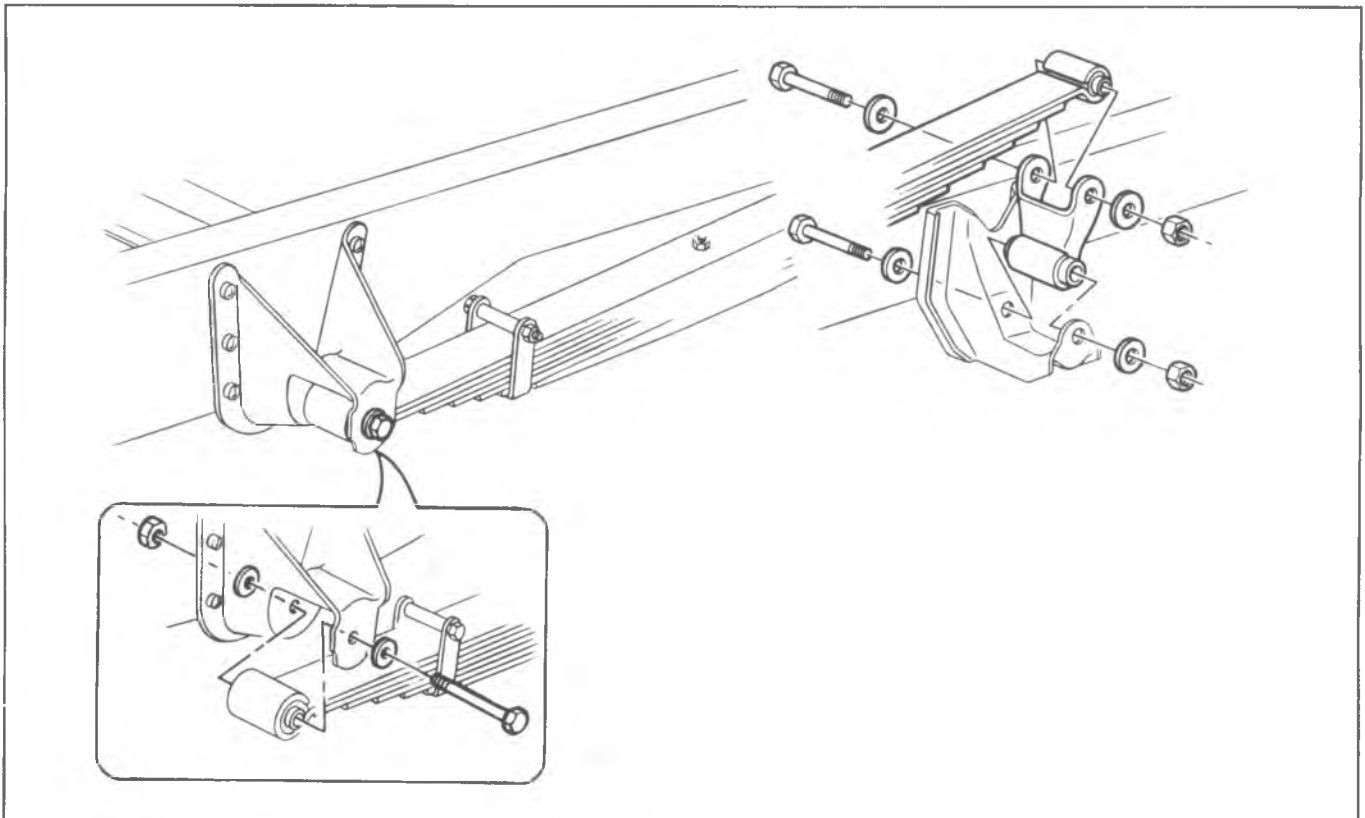
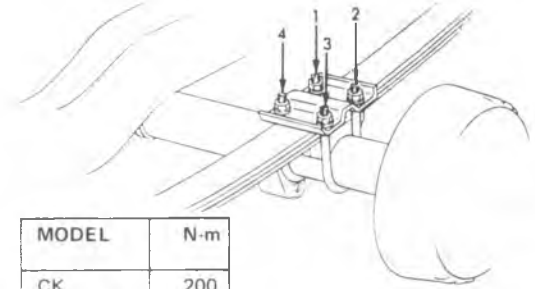

Fig. 3D-21--Rear Spring Installation-P30



1. Install all four nuts to uniform engagement on 'U' Bolts to retain and position anchor plate in design position (perpendicular to axis of 'U' Bolts).
2. Torque all nuts in a diagonal sequence (e.g. 1-3-2-4) to 14.35 N·m.
3. Torque all nuts to full torque using a diagonal sequence.



| MODEL    | N·m |
|----------|-----|
| CK       | 200 |
| G10, G20 | 170 |
| G30      | 240 |

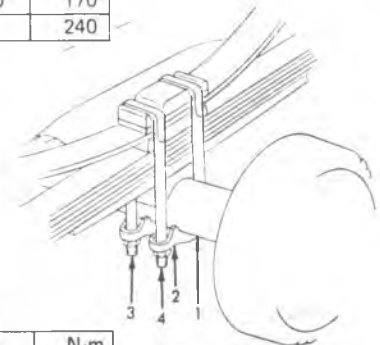

| MODEL | N·m |
|-------|-----|
| CK    | 230 |
| G     | 240 |

100828

Fig. 3D-23--U-Bolt Installation

## SPECIFICATIONS

### TORQUE SPECIFICATION

|                                 | C-K                    | G   | P   |
|---------------------------------|------------------------|---|---|
| Spring-to-Axle "U" Bolt Nuts    |                        |   | P10 190 N·m (140 ft. lbs.)<br>P20 190 N·m (140 ft. lbs.)<br>P30 230 N·m & 170 ft. lbs.)<br>(Exc. W/3/4" Bolt)<br>272 N·m (20 ft. lbs.)<br>(W/3/4" Bolt) |
| Leaf Spring                     |                        |   |   |
| —Front Bushing Bolt             | 150 N·m (110 ft. lbs.) | 122/183* N·m<br>(90/135* ft. lbs.)<br>(G316 . . . 90) | 195 N·m (144 ft. lbs.)  |
| —Rear Shackle Bolt              | 150 N·m (110 ft. lbs.) | 122/183* N·m<br>(90/135* ft. lbs.)<br>(G316 . . . 90) | 195 N·m (144 ft. lbs.)  |
| Shock Absorber                  |                        |   |   |
| —Upper Attachment               | 204 N·m (150 ft. lbs.) | 100 N·m (75 ft. lbs.)                                 | P10 34 N·m (25 ft. lbs.)<br>P20 190 N·m (140 ft. lbs.)<br>P30 68 N·m (50 ft. lbs.)  |
| —Lower Attachment               | 156 N·m (115 ft. lbs.) | 100 N·m (75 ft. lbs.)                                 | 156 N·m (115 ft. lbs.)  |
| Propeller Shaft                 |                        |   |   |
| To Rear Axle (Strap)            | 20 N·m (15 ft. lbs.)   | 20 N·m (15 ft. lbs.)                                  | 20 N·m (15 ft. lbs.)  |
| To Rear Axle ("U" Bolt)         | 28 N·m (20 ft. lbs.)   | 28 N·m (20 ft. lbs.)                                  | 28 N·m (20 ft. lbs.)  |
| Bearing Support-to-Hanger       | 34 N·m (25 ft. lbs.)   | 34 N·m (25 ft. lbs.)                                  | 34 N·m (25 ft. lbs.)  |
| Hanger-to-Frame                 | 60 N·m (45 ft. lbs.)   | —   | —   |
| Rear Stabilizer-to-Anchor Plate | 34 N·m (25 ft. lbs.)   | —   | 34 N·m (25 ft. lbs.)  |

\*When tightening the nut.  
When tightening the bolt.

## SECTION 3E

# WHEELS AND TIRES

**NOTICE:** The Wheel bolt and nut fasteners are an important attaching part in that they could affect the performance of vital components and systems, and/or could result in major repair expense. They must be replaced with one of the same part number or with an equivalent part if replacement becomes necessary. Do not use a replacement part of lesser quality or substitute design. Torque values must be used as specified during reassembly to assure proper retention of this part.

### INDEX

|                                   |      |                                     |       |
|-----------------------------------|------|-------------------------------------|-------|
| General Description.....          | 3E-1 | Tire Inflation Pressure.....        | 3E-3  |
| Replacement Tires.....            | 3E-1 | Correcting Irregular Tire Wear..... | 3E-4  |
| Metric Tires.....                 | 3E-1 | Wheel Installation.....             | 3E-7  |
| Replacement Wheels.....           | 3E-1 | Tire Mounting and Demounting.....   | 3E-8  |
| Certification Label.....          | 3E-2 | Tire Repair.....                    | 3E-9  |
| Service Operations.....           | 3E-2 | Aluminum Wheel Maintenance.....     | 3E-9  |
| Tire Inspection and Rotation..... | 3E-3 | Wheel Nut Torques.....              | 3E-10 |

### GENERAL DESCRIPTION

The factory installed tires and wheels are designed to operate satisfactorily with loads up to and including the full rated load capacity when inflated to the recommended inflation pressures.

Correct tire pressures and driving techniques have an important influence on tire life. Heavy cornering, excessively rapid acceleration, and unnecessary sharp braking increase tire wear.

### REPLACEMENT TIRES

**CAUTION: Do not mix different types of tires on the same vehicle such as radial, bias, and bias-belted tires except in emergencies, because vehicle handling may be seriously affected and may result in loss of control.**

Some truck-type tires and most passenger-car-type radial tires have a TPC Spec. No. (Tire Performance Criteria Specification Number) molded into the tire sidewall near the tire size marking. This shows that the tire meets rigid size and performance standards which were developed for the vehicle. The TPC Spec. No. assures a proper combination of endurance, load capacity, handling, and traction on wet, dry and snow covered surfaces. When replacing tires with tires having the same TPC Spec. No., tires will be compatible with the vehicle. When replacing tires with those not having a TPC spec. use the same size, load range, and construction type (bias, bias-belted, or radial) as the original tires on the vehicle (see the Certification Label Fig. 3E-3). Use of any other size or type tire may affect load carrying capacity, ride, handling, speedometer/odometer calibration, vehicle ground clearance, and tire clearance to the body and chassis. If replacing only a single tire, it should be paired on the same axle with the least worn tire of the others.

All tires on four-wheel drive vehicles must be of equal size (but not necessarily ply rating) and of same tread configuration.

Replace tires when:

1. Tires are worn to a point where 2/32 inch (1.6 millimetres) or less tread remains, or the cord or fabric is exposed. To help detect this, tires have built-in tread wear indicators (Fig. 3E-4) that appear between the tread grooves when the tread depth is 2/32 inch (1.6mm) or less. When the indicators appear in two or more adjacent grooves at three spots around the tire, the tire should be replaced.
2. Tire tread or sidewall is cracked, and, or snagged deep enough to expose the cord or fabric.
3. Tire has a bump, bulge, or split.
4. Tire sustains a puncture, cut, or other injury that can't be correctly repaired because of the size or location of the injury.

**CAUTION: Mounting of wrong size tire can cause personal injury. To help avoid personal injury, mount 16.5 inch diameter tire ONLY on 16.5 inch diameter wheel. Failure to do so could cause tire to explode during inflation and make the tire and wheel a dangerous flying object.**

### METRIC TIRES

Metric tires are available in two load ranges, Standard load and Extra load. Figure 3E-1 shows the meaning of the metric tire format. Most metric tire sizes do not have exact corresponding alpha tire sizes. For example, a P205/75R15 is not exactly equal in size and load carrying capacity to an FR78-15. For this reason, replacement tires should be of the same size, load range, and construction as those originally on the car. If metric tires must be replaced with other sizes, such as in the case of snow tires, a tire dealer should be consulted. Tire companies can best recommend the closest match of alpha to metric sizes within their own tire lines.

The metric term for tire inflation pressure is the Kilopascal (kPa). Tire pressure will usually be printed in both kPa and psi. Metric tire gages are available from tool suppliers. The chart (Fig. 3E-2) converts commonly-used inflation pressures from kPa to psi.

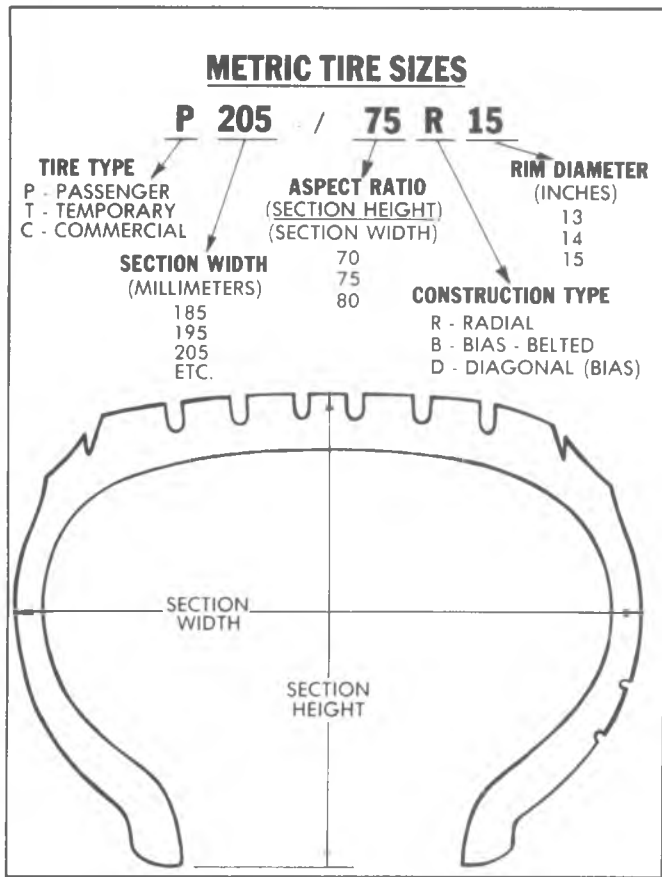

Fig. 3E-1--Metric Tire Size Format

### REPLACEMENT WHEELS

Wheels must be replaced if they become damaged (for example: bent, heavily rusted, leak air) or if wheel nuts often become loose. Do not use bent wheels which have been straightened, and do not use inner tubes in leaking wheels which are designed for tubeless tires. Such wheels may have structural damage and could fail without warning.

The wheels originally equipped on the vehicle will provide optimum life up to the maximum load and inflation pressures shown in the Wheel Code and Limits Chart. Maximum loads, maximum inflation pressures, wheel identification codes, and wheel sizes are stamped on each wheel. Service tested and approved wheels are available from service. When obtaining wheels for any reason from any other source, the replacement wheels should be equal in load capacity, inflation pressure capacity, diameter,

### INFLATION PRESSURE CONVERSION CHART (KILOPASCALS TO PSI)

| kPa | psi | kPa | psi |
|-----|-----|-----|-----|
| 140 | 20  | 215 | 31  |
| 145 | 21  | 220 | 32  |
| 155 | 22  | 230 | 33  |
| 160 | 23  | 235 | 34  |
| 165 | 24  | 240 | 35  |
| 170 | 25  | 250 | 36  |
| 180 | 26  | 275 | 40  |
| 185 | 27  | 310 | 45  |
| 190 | 28  | 345 | 50  |
| 200 | 29  | 380 | 55  |
| 205 | 30  | 415 | 60  |

Conversion: 6.9 kPa = 1 psi

Fig. 3E-2--Inflation Pressure Conversion

width, offset and mounting configurations to those originally installed on the vehicle.

A wheel of the wrong size or type may adversely affect load carrying capacity, wheel and bearing life, brake cooling, speedometer/odometer calibration, stopping ability, headlight aim, bumper height, vehicle ground clearance, and tire clearance to the body and chassis. Replacement with "used" wheels is not advised: they may have been subjected to harsh treatment or very high mileage and could fail without warning.

The use of wheels and/or tires with higher load carrying limits than originally equipped on the vehicle does not in itself increase the GAWR or the GVWR of the vehicle.



Fig. 3E-4--Tread Wear Indicators

MFD BY GENERAL MOTORS CORP

|   |   |   |
|---|---|---|
| <p><b>GM</b></p> <p>08/78<br/>GVWR<br/>14000/6350</p> <p>LB/kg<br/>TIRES<br/>RIMS<br/>PSI/kPa</p> | <p>GAWR FRT<br/>4000/1814<br/>10 5 X 16 5D<br/>16 5 X 9 75<br/>COLD DUAL<br/>36/248</p> | <p>GAWR RR<br/>10000 4536<br/>10 5 X 16 5D<br/>16 6 X 9 75<br/>42/290</p> |
|---|---|---|

THIS VEHICLE CONFORMS TO ALL APPLICABLE FEDERAL MOTOR VEHICLE SAFETY STANDARDS

|                         |                      |
|-------------------------|----------------------|
| ON THE DATE MANUFACTURE | SHOWN ABOVE          |
| CGQ1691100001           | BUS - NOT SCHOOL BUS |

SEE OWNERS MANUAL FOR ADDITIONAL INFORMATION

EXAMPLE ONLY

Fig. 3E-3--Certification Label

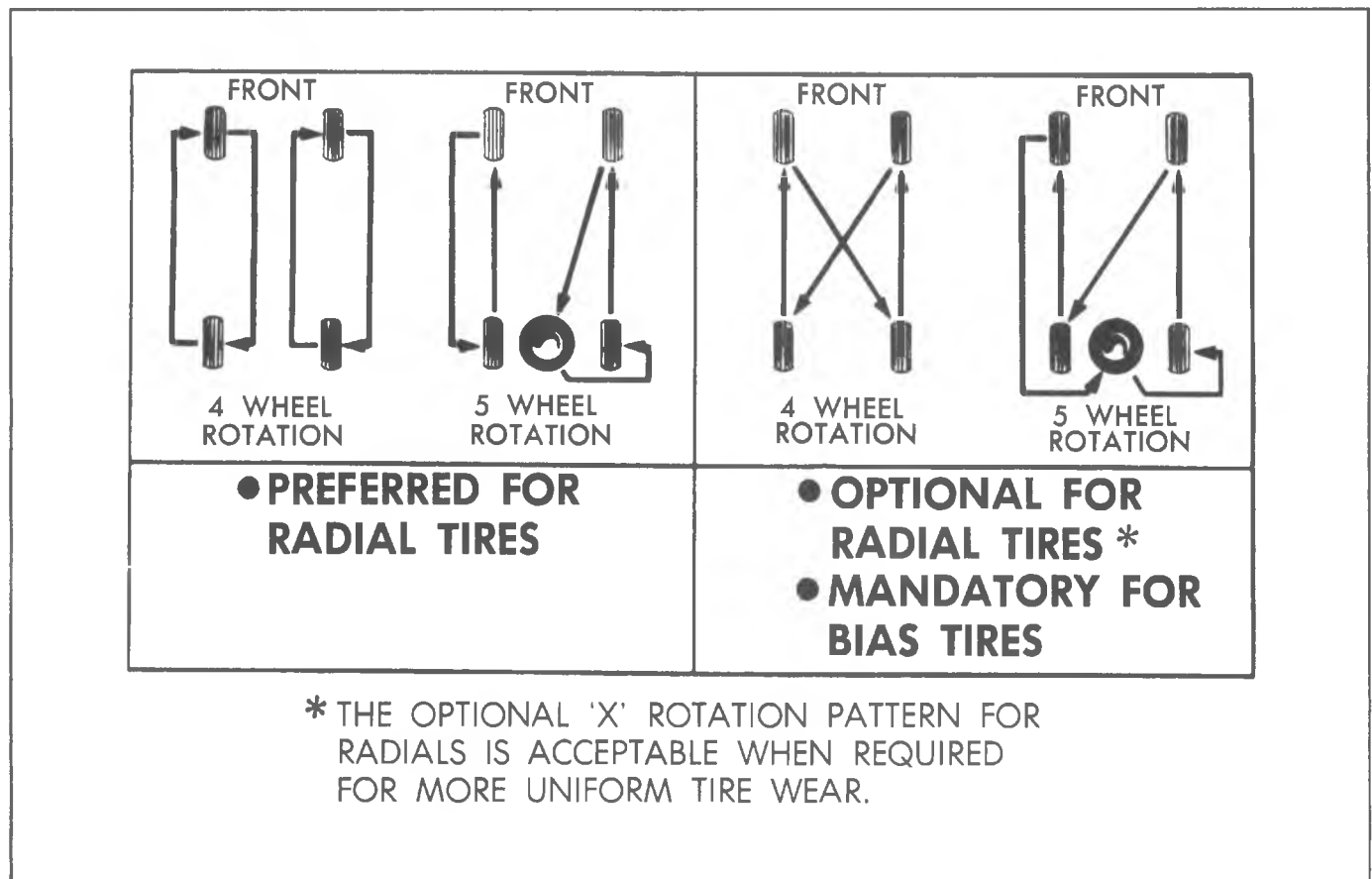

Fig. 3E-5--Tire Rotation

## SERVICE OPERATIONS

**CAUTION:** Servicing of tires mounted on multi-piece rims requires proper tools, safety equipment and specialized training. Severe injuries can result from improper servicing techniques. It is recommended that tires on multi-piece rims be serviced only by competent personnel with proper equipment or by competent truck tire repair shops.

### TIRE INSPECTION AND ROTATION (Figs. 3E-4, 3E-5)

Front and rear tires perform different jobs and can wear differently depending on the type of roads driven, individual driving habits, etc. To obtain maximum tire life, tires should be inspected at intervals shown in Section OB. For the longest tire life, any time irregular wear is noticed, the tires should be inspected and rotated and the cause of the uneven wear corrected. Be certain to check wheel nut tightness and to adjust the tire pressures, front and rear, after rotation to agree with those recommended in the tire inflation charts.

The outer tire on a dual wheel will skid or drag on a turn because of the difference in the turning radii of the inner and outer tires. This results in faster wear of the outer tire. In general, the tire with the largest diameter or least wear should be at the outside of each dual wheel. In addition, when trucks are operated continuously on high crown roads, an increase in air pressure of from 5 to 10 PSI in the outside tire of each dual produces maximum tire life.

As shown in Fig. 3E-5, the X method of rotation is allowed with radial tires if necessary. Due to their design, radial tires tend to wear faster in the shoulder area particularly in the front positions. This makes regular rotation especially necessary.

### INFLATION PRESSURE

The maximum cold inflation pressures for the factory installed tires are listed on the Certification Label. Tires must be inflated to these pressures when the GVWR or an axle GAWR is reached. Improper tire inflation pressures for the load the vehicle is carrying can adversely affect tire life and vehicle performance.

For improved ride comfort in vehicles rated at 8600 GVWR, it is permissible to use the lower tire pressure values shown on the label located on the rear edge of the driver's door provided there is a maximum of 200 lbs. cargo, no slide in camper, and there are three or less occupants.

Too low an air pressure can result in tire overloading, abnormal tire wear, adverse vehicle handling, and reduced fuel economy. The tire flexes more and can build up excessive heat, weakening the tire and increasing susceptibility to damage or failure. Too high an air pressure can result in abnormal wear, harsh vehicle ride, and increased susceptibility to damage from road hazards. Lower inflation pressures should be used only with reduced vehicle loads and the rear tire pressure should be equal to or greater than the front pressure on single wheel application. After determining the load on each tire by

TIRE AND WHEEL LOAD LIMIT CHARTS

(TIRE & WHEEL LOAD LIMITS ARE SHOWN BELOW VEHICLE LOADING MUST BE LIMITED SUCH THAT NEITHER THE WHEEL OR TIRE INFLATION PRESSURE OR LOAD LIMITS ARE EXCEEDED)

RADIAL TIRE SIZE AND LOAD LIMITS - LBS (kg)

| Tire Size | Load Range | Inflation Pressure - PSI (kPa) |          |          |          |          |          |
|-----------|------------|--------------------------------|----------|----------|----------|----------|----------|
|           |            | 36 (250)                       | 44 (300) | 51 (350) | 58 (400) | 65 (450) | 73 (500) |

METRIC RADIAL TIRES USED AS SINGLES

| Tire Size   | Load Range | 1532 (695) | 1742 (790) | 1940 (880)  | 2127 (965)  | 2315 (1050) |             |             |
|-------------|------------|------------|------------|-------------|-------------|-------------|-------------|-------------|
| LT215/85R16 | C          | 1532 (695) | 1742 (790) | 1940 (880)  |             |             |             |             |
| LT215/85R16 | D          | 1532 (695) | 1742 (790) | 1940 (880)  | 2127 (965)  | 2315 (1050) |             |             |
| LT235/85R16 | D          | 1742 (790) | 1984 (900) | 2205 (1000) | 2425 (1100) | 2623 (1190) |             |             |
| LT235/85R16 | E          | 1742 (790) | 1984 (900) | 2205 (1000) | 2425 (1100) | 2623 (1190) | 2844 (1290) | 3042 (1380) |

METRIC RADIAL TIRES USED AS DUALS

| Tire Size   | Load Range | 1389 (630) | 1587 (720) | 1764 (800) | 1918 (870) | 2105 (955) |  |  |
|-------------|------------|------------|------------|------------|------------|------------|--|--|
| LT215/85R16 | C          | 1389 (630) | 1587 (720) | 1764 (800) |            |            |  |  |
| LT215/85R16 | D          | 1389 (630) | 1587 (720) | 1764 (800) | 1918 (870) | 2105 (955) |  |  |

BIAS TIRE SIZE AND LOAD LIMITS - LBS (kg)

| Tire Size | Load Range | Inflation Pressure - PSI (kPa) |          |          |          |          |          |          |          |
|-----------|------------|--------------------------------|----------|----------|----------|----------|----------|----------|----------|
|           |            | 30 (207)                       | 35 (241) | 40 (276) | 45 (310) | 50 (345) | 55 (379) | 60 (414) | 65 (448) |

BIAS TIRES USED AS SINGLES

| Tire Size | Load Range | 1620 (735) | 1770 (803) | 1930 (875) | 2060 (934) | 2190 (993) | 2310 (1048) | 2440 (1107) | 2560 (1161) | 2670 (1211) | 2780 (1261) |
|-----------|------------|------------|------------|------------|------------|------------|-------------|-------------|-------------|-------------|-------------|
| 7.50-16   | C          | 1620 (735) | 1770 (803) | 1930 (875) | 2060 (934) |            |             |             |             |             |             |
| 7.50-16   | D          | 1620 (735) | 1770 (803) | 1930 (875) | 2060 (934) | 2190 (993) | 2310 (1048) | 2440 (1107) |             |             |             |
| 7.50-16   | E          | 1620 (735) | 1770 (803) | 1930 (875) | 2060 (934) | 2190 (993) | 2310 (1048) | 2440 (1107) | 2560 (1161) | 2670 (1211) | 2780 (1261) |

BIAS TIRES USED AS DUALS

| Tire Size | Load Range | 1430 (649) | 1565 (710) | 1690 (767) | 1815 (823) | 1930 (875) | 2040 (925) | 2140 (971) |
|-----------|------------|------------|------------|------------|------------|------------|------------|------------|
| 7.50-16   | C          | 1430 (649) | 1565 (710) | 1690 (767) | 1815 (823) |            |            |            |
| 7.50-16   | D          | 1430 (649) | 1565 (710) | 1690 (767) | 1815 (823) | 1930 (875) | 2040 (925) | 2140 (971) |

WHEEL CODE AND LIMITS

| Code | Wheel Size | Max Load Lbs (kg) | Max Pressure PSI (kPa) |
|------|------------|-------------------|------------------------|
| AA   | 16x6.5 L   | 3045 (1381)       | 90 (621)               |
| AF   | 16x6 K     | 2440 (1107)       | 75 (517)               |
| BF   | 16x6.5 L   | 2780 (1261)       | 85 (586)               |
| BJ   | 15x8JJ     | 1910 (866)        | 40 (276)               |
| BK   | 15x7 JJ    | 1670 (757)        | 40 (276)               |
| BM   | 15x8 JJ    | 2030 (921)        | 40 (276)               |

| Code | Wheel Size | Max Load Lbs (kg) | Max Pressure PSI (kPa) |
|------|------------|-------------------|------------------------|
| CF   | 15x7 JJ    | 1670 (757)        | 40 (276)               |
| CK   | 15x8 JJ    | 1910 (866)        | 40 (276)               |
| UW   | 15x7 JJ    | 2030 (921)        | 41 (283)               |
| UX   | 15x7 JJ    | 2030 (921)        | 41 (283)               |
| XH   | 15x6 JJ    | 1585 (719)        | 40 (276)               |
| XW   | 15x6 JJ    | 1910 (866)        | 70 (483)               |
| XX   | 15x6 JJ    | 2040 (925)        | 70 (483)               |
| ZC   | 15x8 JJ    | 2030 (921)        | 40 (276)               |

Fig. 3E-6--Tire/Wheel Load and Inflation Pressure

weighing the vehicle on a scale, the correct cold inflation pressures for the actual tire loads can be obtained from the Tire/Wheel Load and Inflation Pressure Charts shown in this section. Refer to Section 0B for additional information on inflation pressure.

**CORRECTING IRREGULAR TIRE WEAR**

**Heel and Toe Wear**

This is a saw-toothed effect where one end of each tread block is worn more than the other. The end that wears is the one that first grips the road when the brakes are applied.

Heel and toe wear is less noticeable on rear tires than on front tires, because the propelling action of the rear wheels creates a force which tends to wear the opposite end of the tread blocks. The two forces, propelling and braking, make for more even wear of the rear tires, whereas only the braking forces act on the front wheels, and the saw-tooth effect is more noticeable.

A certain amount of heel and toe wear is normal. Excessive wear is usually due to high speed driving and

excessive use of brakes. The best remedy, in addition to cautioning the owner on his driving habits, is to interchange tires regularly.

**Side Wear**

This may be caused by incorrect wheel camber, underinflation, high cambered roads or by taking corners at too high a rate of speed. The first two causes are the most common. Camber wear can be readily identified because it occurs only on one side of the treads, whereas underinflation causes wear on both sides. Camber wear requires correction of the camber first and then interchanging tires. There is, of course, no correction for high cambered roads. Cornering wear is discussed further on.

**Misalignment Wear**

This is wear due to excessive toe-in or toe-out. In either case, tires will revolve with a side motion and scrape the tread rubber off. If misalignment is severe, the rubber will be scraped off of both tires; if slight, only one will be affected. The scraping action against the face

**TIRE AND WHEEL LOAD LIMIT CHARTS**

(TIRE & WHEEL LOAD LIMITS ARE SHOWN BELOW. VEHICLE LOADING MUST BE LIMITED SUCH THAT NEITHER THE WHEEL OR TIRE INFLATION PRESSURE OR LOAD LIMITS ARE EXCEEDED)

**TIRE SIZE AND LOAD LIMITS – LBS (kg)**

| Tire Size | Load Range | Inflation Pressure – PSI (kPa) |          |          |          |          |          |          |          |          |          |
|-----------|------------|--------------------------------|----------|----------|----------|----------|----------|----------|----------|----------|----------|
|           |            | 30 (207)                       | 35 (241) | 40 (276) | 45 (310) | 50 (345) | 55 (379) | 60 (414) | 65 (448) | 70 (483) | 75 (517) |

**BIAS TIRES USED AS SINGLES**

|           |   |            |            |            |            |            |             |             |             |             |             |  |
|-----------|---|------------|------------|------------|------------|------------|-------------|-------------|-------------|-------------|-------------|--|
| 8.00-16.5 | C | 1360 (617) | 1490 (676) | 1610 (730) | 1730 (785) |            |             |             |             |             |             |  |
| 8.00-16.5 | D | 1360 (617) | 1490 (676) | 1610 (730) | 1730 (785) | 1840 (835) | 1945 (882)  | 2045 (928)  |             |             |             |  |
| 8.75-16.5 | D | 1570 (712) | 1720 (780) | 1850 (839) | 1990 (903) | 2110 (957) | 2240 (1016) | 2350 (1066) |             |             |             |  |
| 8.75-16.5 | E | 1570 (712) | 1720 (780) | 1850 (839) | 1990 (903) | 2110 (957) | 2240 (1016) | 2350 (1066) | 2470 (1120) | 2570 (1166) | 2680 (1216) |  |

**BIAS TIRES USED AS DUALS**

|           |   |            |            |            |            |            |            |            |  |  |  |  |
|-----------|---|------------|------------|------------|------------|------------|------------|------------|--|--|--|--|
| 8.00-16.5 | C | 1195 (542) | 1310 (594) | 1415 (642) | 1520 (689) |            |            |            |  |  |  |  |
| 8.00-16.5 | D | 1195 (542) | 1310 (594) | 1415 (642) | 1520 (689) | 1620 (735) | 1710 (776) | 1800 (816) |  |  |  |  |

**RADIAL TIRES USED AS DUALS**

|           |   |  |            |            |            |            |            |             |             |             |             |             |
|-----------|---|--|------------|------------|------------|------------|------------|-------------|-------------|-------------|-------------|-------------|
| 8.75R16.5 | E |  | 1570 (712) | 1720 (780) | 1850 (839) | 1990 (903) | 2110 (957) | 2240 (1016) | 2350 (1066) | 2470 (1120) | 2570 (1166) | 2680 (1216) |
|-----------|---|--|------------|------------|------------|------------|------------|-------------|-------------|-------------|-------------|-------------|

**WHEEL CODE AND LIMITS**

| Code | Wheel Size | Max Load Lbs (kg) | Max Pressure PSI (kPa) | Code    | Wheel Size | Max Load Lbs (kg) | Max Pressure PSI (kPa) |
|------|------------|-------------------|------------------------|---------|------------|-------------------|------------------------|
| BR   | 15x7 JJ    | 1690 (767)        | 40 (276)               | YD      | 16.5x6     | 2680 (1216)       | 85 (586)               |
| CD   | 15x6.5 JJ  | 1690 (767)        | 40 (276)               | YH      | 16.5x6     | 2680 (1216)       | 85 (586)               |
| XH   | 15x6 JJ    | 1585 (719)        | 40 (276)               | YJ      | 16.5x6.75  | 2680 (1216)       | 85 (586)               |
| XW   | 15x6 JJ    | 1910 (866)        | 70 (483)               | NO CODE | 15x6.5 JJ  | 1690 (207)        | 40 (276)               |

Fig. 3E-7--Tire/Wheel Load and Inflation Pressure-G Models

**TIRE AND WHEEL LOAD LIMIT CHARTS**

(TIRE & WHEEL LOAD LIMITS ARE SHOWN BELOW. VEHICLE LOADING MUST BE LIMITED SUCH THAT NEITHER THE WHEEL OR TIRE INFLATION PRESSURE OR LOAD LIMITS ARE EXCEEDED)

**RADIAL TIRE SIZE AND LOAD LIMITS – LBS (kg)**

| Tire Size | Load Range | Inflation Pressure – PSI (kPa) |          |          |          |          |          |          |
|-----------|------------|--------------------------------|----------|----------|----------|----------|----------|----------|
|           |            | 36 (250)                       | 44 (300) | 51 (350) | 58 (400) | 65 (450) | 73 (500) | 80 (550) |

**METRIC RADIAL TIRES USED AS SINGLES**

| Tire Size   | Load Range | 36 (250)   | 44 (300)   | 51 (350)    | 58 (400)    | 65 (450)    | 73 (500)    | 80 (550)    |
|-------------|------------|------------|------------|-------------|-------------|-------------|-------------|-------------|
| LT215/85R16 | C          | 1532 (695) | 1742 (790) | 1940 (880)  |             |             |             |             |
| LT215/85R16 | D          | 1532 (695) | 1742 (790) | 1940 (880)  | 2127 (965)  | 2315 (1050) |             |             |
| LT235/85R16 | D          | 1742 (790) | 1984 (900) | 2205 (1000) | 2425 (1100) | 2623 (1190) |             |             |
| LT235/85R16 | E          | 1742 (790) | 1984 (900) | 2205 (1000) | 2425 (1100) | 2623 (1190) | 2844 (1290) | 3042 (1380) |

**METRIC RADIAL TIRES USED AS DUALS**

| Tire Size   | Load Range | 36 (250)   | 44 (300)   | 51 (350)   | 58 (400)   | 65 (450)   | 73 (500) | 80 (550) |
|-------------|------------|------------|------------|------------|------------|------------|----------|----------|
| LT215/85R16 | C          | 1389 (630) | 1587 (720) | 1764 (800) |            |            |          |          |
| LT215/85R16 | D          | 1389 (630) | 1587 (720) | 1764 (800) | 1918 (870) | 2105 (955) |          |          |

| Tire Size | Load Range | Inflation Pressure – PSI (kPa) |          |          |          |          |          |          |
|-----------|------------|--------------------------------|----------|----------|----------|----------|----------|----------|
|           |            | 45 (310)                       | 50 (345) | 55 (379) | 60 (414) | 65 (448) | 70 (483) | 75 (517) |

**RADIAL TIRES USED AS SINGLES**

| Tire Size | Load Range | 45 (310) | 50 (345) | 55 (379)   | 60 (414)    | 65 (448)    | 70 (483)    | 75 (517)    | 80 (552)    |
|-----------|------------|----------|----------|------------|-------------|-------------|-------------|-------------|-------------|
| 8R19.5    | D          |          |          | 2110 (957) | 2270 (1030) | 2410 (1093) | 2540 (1152) | 2680 (1216) | 2800 (1270) |

**RADIAL TIRES USED AS DUALS**

| Tire Size | Load Range | 45 (310)   | 50 (345)   | 55 (379)   | 60 (414)    | 65 (448)    | 70 (483)    | 75 (517) | 80 (552) |
|-----------|------------|------------|------------|------------|-------------|-------------|-------------|----------|----------|
| 8R19.5    | D          | 1850 (839) | 1990 (903) | 2110 (957) | 2230 (1012) | 2350 (1066) | 2460 (1116) |          |          |

**BIAS TIRE SIZE AND LOAD LIMITS – LBS (kg)**

| Tire Size | Load Range | Inflation Pressure – PSI (kPa) |          |          |          |          |          |          |          |          |          |
|-----------|------------|--------------------------------|----------|----------|----------|----------|----------|----------|----------|----------|----------|
|           |            | 30 (207)                       | 35 (241) | 40 (276) | 45 (310) | 50 (345) | 55 (379) | 60 (414) | 65 (448) | 70 (483) | 75 (517) |

**BIAS TIRES USED AS SINGLES**

| Tire Size | Load Range | 30 (207)   | 35 (241)   | 40 (276)   | 45 (310)   | 50 (345)   | 55 (379)    | 60 (414)    | 65 (448)    | 70 (483)    | 75 (517)    |
|-----------|------------|------------|------------|------------|------------|------------|-------------|-------------|-------------|-------------|-------------|
| 7.50-16   | C          | 1620 (735) | 1770 (803) | 1930 (875) | 2060 (934) |            |             |             |             |             |             |
| 7.50-16   | D          | 1620 (735) | 1770 (803) | 1930 (875) | 2060 (934) | 2190 (993) | 2310 (1048) | 2440 (1107) |             |             |             |
| 7.50-16   | E          | 1620 (735) | 1770 (803) | 1930 (875) | 2060 (934) | 2190 (993) | 2310 (1048) | 2440 (1107) | 2560 (1161) | 2670 (1211) | 2780 (1261) |
| 8-19.5    | D, E       |            |            |            |            | 2110 (957) | 2270 (1030) | 2410 (1093) | 2540 (1152) | 2680 (1216) | 2800 (1270) |

**BIAS TIRES USED AS DUALS**

| Tire Size | Load Range | 30 (207)   | 35 (241)   | 40 (276)   | 45 (310)   | 50 (345)   | 55 (379)    | 60 (414)    | 65 (448)    | 70 (483)    | 75 (517)    |
|-----------|------------|------------|------------|------------|------------|------------|-------------|-------------|-------------|-------------|-------------|
| 7.50-16   | C          | 1430 (649) | 1565 (710) | 1690 (767) | 1815 (823) |            |             |             |             |             |             |
| 7.50-16   | D          | 1430 (649) | 1565 (710) | 1690 (767) | 1815 (823) | 1930 (875) | 2040 (925)  | 2140 (971)  |             |             |             |
| 8-19.5    | D          |            |            | 1850 (839) | 1990 (903) | 2110 (957) | 2230 (1012) | 2350 (1066) | 2460 (1116) |             |             |
| 8-19.5    | E          |            |            | 1850 (839) | 1990 (903) | 2110 (957) | 2230 (1012) | 2350 (1066) | 2460 (1116) | 2570 (1166) | 2680 (1216) |

**WHEEL CODE AND LIMITS**

| Code | Wheel Size | Max Load Lbs (kg) | Max Pressure PSI (kPa) |
|------|------------|-------------------|------------------------|
| AA   | 16x6.5 L   | 3045 (1381)       | 90 (621)               |
| AF   | 16x6 K     | 2440 (1107)       | 75 (517)               |
| BF   | 16x6.5 L   | 2780 (1261)       | 85 (586)               |
| ZT   | 19.5x6     | 2540 (1152)       | 80 (552)               |
| ZY   | 19.5x6     | 2780 (1261)       | 95 (655)               |

Fig. 3E-8--Tire/Wheel Load and Inflation Pressure-P Models



of the tire causes a small feather edge of rubber to appear on one side of the tread and this feather edge is certain indication of misalignment. The remedy is readjusting toe-in, or rechecking the entire front end alignment if necessary.

#### Uneven Wear

Uneven or spotty wear is due to such irregularities as unequal caster or camber, bent front suspension parts, out-of-balance wheels, brake drums out of round, brakes out of adjustment or other mechanical conditions. The remedy in each case consists of locating the mechanical defect and correcting it.

#### Cornering Wear

When a truck makes an extremely fast turn, the weight is shifted from an even loading on all wheels to an abnormal load on the tires on the outside of the curve and a very light load on the inside tires, due to centrifugal force. This unequal loading may have two unfavorable results.

**First**, the rear tire on the inside of the curve may be relieved of so much load that it is no longer geared to the road and it slips, grinding off the tread on the inside half of the tire at an excessive rate. This type of tire shows much the same appearance of tread wear as tire wear caused by negative camber.

**Second**, the transfer of weight may also overload the outside tires so much that they are laterally distorted resulting in excessive wear on the outside half of the tire, producing a type of wear like that caused by excessive positive camber.

Cornering wear can be most easily distinguished from abnormal camber wear by the rounding of the outside shoulder or edge of the tire and by the roughening of the tread surface which denotes abrasion.

Cornering wear often produces a fin or raised portion along the inside edge of each row in the tread pattern. In some cases this fin is almost as pronounced as a toe-in fin, and in others, it tapers into a row of tread blocks to such an extent that the tire has a definite "step wear" appearance.

The only remedy for cornering wear is proper instruction of operators. Driving more slowly on curves and turns will avoid grinding rubber off tires. To offset normal cornering wear as much as possible tires should be interchanged at regular intervals.

#### Wheel and Tire Balancing

It is desirable from the standpoints of tire wear and vehicle ride and handling ease to maintain proper balance of wheel and tire assemblies on all models. This may be accomplished by either of the two types of balancing systems in correct use which balance wheels either on the vehicle or off. The "on the vehicle" type, however, is the more desirable in that all rolling components (brake drums, bearings, seals, etc.) are included in the balancing procedure and thereby have any existing unbalance corrected.

#### Truck Wheel Balance Weights

All truck wheels equipped with a tubular side ring (rolled flange rim) on the outboard side of the wheel rims require special design weights to fit. Dynamic balancing can be accomplished through use of these special balance weights which are designed only for installations on the

outboard side of these wheels. Conventional weights fit only the inboard side of these wheels.

#### Static Balance

Static balance (sometimes called still balance) is the equal distribution of weight of the wheel and tire assembly about the axis of rotation in such a manner that the assembly has no tendency to rotate by itself, regardless of its position. For example: A wheel with chunk of dirt on the rim will always rotate by itself until the heavy side is at the bottom. Any wheel with a heavy side like this is statically out of balance. Static unbalance of a wheel causes a hopping or pounding action (up and down) which frequently leads to wheel "flutter" and quite often to wheel "tramp".

#### Dynamic Balance

Dynamic balance (sometimes called running balance) means that the wheel must be in static balance, and also run smoothly at all speeds.

To insure successful, accurate balancing, the following precautions must be observed:

- Wheel and tire must be clean and free from all foreign matter.
- The tires should be in good condition and properly mounted with the balance mark on the tire, if any, lined up with the valve.
- Bent wheels that have runout over 1/16" should be replaced.
- Inspect tire and wheel assembly to determine if an eccentric or out-of-round condition exists. Note that this condition, if severe, cannot be "balanced out". An assembly which has an out-of-round condition exceeding 3/16" on tire sizes through 19.5" is not suitable for use on the front of the vehicle. Its use on the rear should be governed by its general condition and whether the roundness defect seriously detracts from overall ride quality.
- When balancing wheels and tires, it is recommended that the instructions covering the operation of the wheel balancer being used be closely followed.
- When balancing truck type nylon tires, tires must be hot (run for several miles) before raising vehicle to balance so that flat spot is eliminated. A tire which is flat spotted will be incorrectly balanced.
- On 10 and 20 series trucks, do not attempt to externally drive the wheels with the transfer case in the neutral position. Although, the transfer case will be uncoupled from the transmission, the front and rear drive trains will be coupled through the transfer case. For example, attempting to balance a rear wheel on the vehicle will cause one or both of the front wheels to also be driven. The wheels may be dynamically balanced on the vehicle with the transfer case in the 2H position. The transfer case neutral position should only be used when it becomes necessary to uncouple the transmission from the transfer case.

#### WHEEL INSTALLATION

##### Single Wheels

When installing the tire and wheel on the vehicle, the following procedure should be followed:

After wheel nuts are put on loosely, turn the wheel

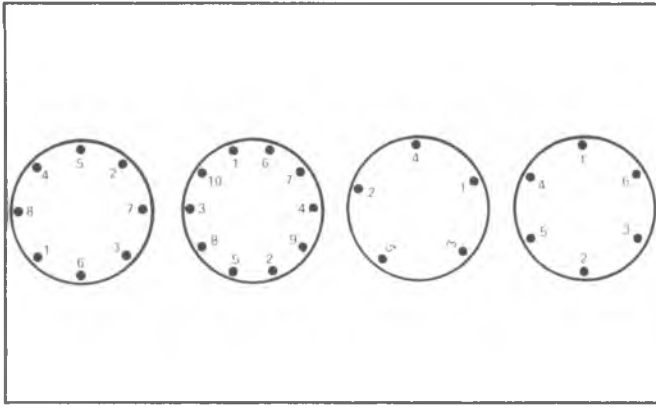

Fig. 3E-9--Wheel Nut Tightening Sequence

until one nut is at the top of the bolt circle; tighten the nut just snug. Snug up the remaining nuts criss-cross to minimize runout, then tighten the nuts to the recommended torque alternately and evenly to avoid excessive runout.

**CAUTION:** Before re-installing wheels, remove any build up of corrosion of the wheel mounting surface and brake drum or disc mounting surface by scraping and wire brushing. Installing wheels without good metal-to-metal contact at the mounting surfaces can cause wheel nuts to loosen which can later allow a wheel to come off while the vehicle is moving, possibly causing loss of control.

#### Dual Wheels

When installing wheels on vehicles with dual rear wheels:

1. Install inner and outer wheel and clamp ring on rear, or wheel and clamp ring on front (be sure pins on clamp ring face outboard).
2. Install and snug nuts finger tight.
3. Torque nuts to specified torque in sequence shown in Fig. 3E-9.

Lateral runout should not exceed 1/8" on front wheel or 3/16" on rear wheel.

#### Attachment of Dual Wheels On P30 Models

To assure secure attachment of the dual disc wheels, it is important that all dirt or rust scale be removed from the mating surface of the wheels, hub, and clamp ring as well as the stud and nut. **MANUALLY TORQUE** to specifications.

#### Inspection for Leaks

1. With wheel assembly removed from vehicle, inflate the tire to recommended operating pressure.
2. Check for leaks at rim bead by placing wheel and tire horizontal and allowing water to stand in groove between rim and tire. Check for other leaks by lowering assembly into water tank or running water over tire.

#### Installing Synthetic Tubes

**NOTICE:** When tube and flap are not properly lubricated and mounted, they will stretch thin in the tire bead and rim region. This will cause premature failure.

1. Before installing tube in tire, clean inside of casing thoroughly.
2. Insert tube in tire and inflate until it is nearly rounded out.
3. Inspect rim for rust scale and bent flanges--clean rust scale and straighten flanges where necessary.
4. Using a brush or cloth swab, apply a solution of neutral vegetable oil soap to the inside and outside of tire beads and also the the rim side of the tube. Do not allow soap solution to run down into tire.
5. When mounting tire and tube on a drop center rim, follow the standard procedure. Be sure tire is centered on rim so that beads are out of rim well before inflating. Do not allow tire to hang loosely on wheel while inflating.
6. Center valve and pull it firmly against the rim. Hold in this position and inflate until tire beads are firmly seated on rim against flanges.
7. Completely deflate tire by removing valve core.
8. Reinflate tire to recommended pressure.

#### TUBELESS TIRES

Tubeless tires mounted on one piece full drop center rims are standard on most trucks.

#### Mounting and Demounting

Use a tire changing machine to mount or demount tires. Follow the equipment manufacturer's instructions. Do not use hand tools or tire irons alone to change tire as they may damage the tire beads or wheel rim.

Rim bead seats should be cleaned with a wire brush or coarse steel wool to remove lubricants, old rubber, and light rust. Before mounting or demounting a tire, the bead area should be well lubricated with an approved tire lubricant.

After mounting, inflate to 40 psi so that beads are completely seated.

**CAUTION:** Do not stand over tire when inflating. Bead may break when beads snaps over safety hump and cause serious personal injury.

**CAUTION:** Do not exceed 275 kPa (40 psi) pressure when inflating. If 275 kPa (40 psi) pressure will not seat beads, deflate, re-lubricate and reinflate. Overinflation may cause the bead to break and cause serious personal injury.

Install valve core and inflate to proper pressure. Check the locating rings of the tire to be sure they show around the rim flanges on both sides (Fig. 3E-10).

#### RADIAL TIRES

Recommended truck tire mounting and inflation procedures are especially important with radial truck tires. Failure to follow these recommendations can cause bead deformation in both tube type and tubeless tires due to incorrect bead seating. Bead deformation may lead to chafing, lower sidewall and bead area cracking, demounting difficulties, eccentric wear, ride vibration and non-retreadable casing.

#### Mounting

To insure correct mounting and bead seating and to prevent bead deformation, the following steps must be taken:

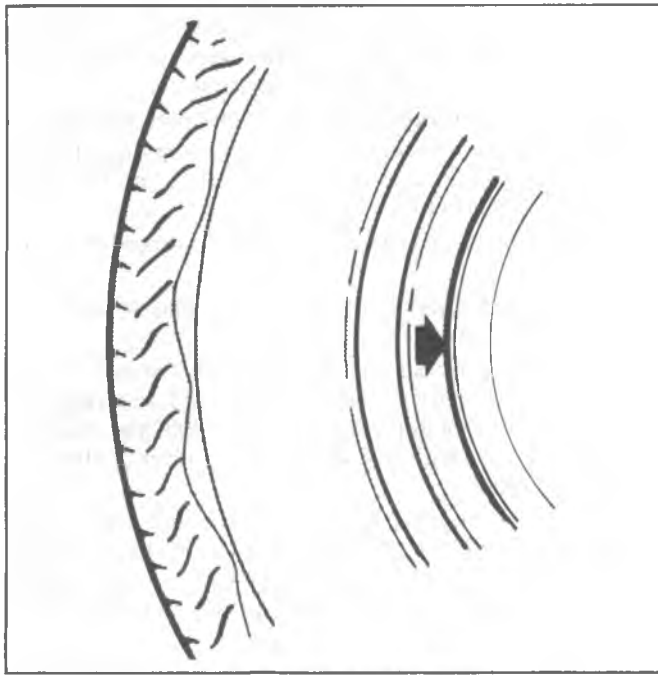

Fig. 3E-10--Tire Locating Rings

#### A. Tube Type Tires

1. Only use rims approved for radial tire usage by rim manufacturer. Thoroughly clean rim parts, removing all rust and other foreign material. Make sure rim parts match and are not sprung or broken.
2. Thoroughly lubricate tire beads, portion of tube between beads, and flaps with an approved rubber lubricant. Radial tubes are identifiable by the letter "R" in the size designation. Example 100R20. Also, to further identify the radial tube, a red band on the valve stem has been required since March, 1975. Radial flaps are also identified by the letter "R". Example - 20R8.

**NOTICE:** Do not use silicone base lubricants - this could cause the tire to slip on the wheel.

3. Double inflate. Inflate to operating pressure, deflate completely and reinflate to operating pressure. This allows tube, flap and tire to fit together properly.
4. Check bead seating. Visually check slot and side ring gap (on two piece rim) to make sure bead is seated. The flange and one of the three lower sidewall rim line rings while the tire is laying flat (measurements should be taken each 90° around the circumference of the rim flange). If spacing is uneven around bead from side to side, repeat Step 1 through 3, and recheck.

#### B. Tubeless Tires.

1. Only use rims approved for radial tire usage by rim manufacturer. Thoroughly clean rim, removing all rust and other foreign material.
2. Thoroughly lubricate tire beads and rim bead seats with an approved rubber lubricant.

**NOTICE:** Do not use silicone base lubricants - this could cause the tire to slip on the wheel.

3. Inflation. Inflate tire to operating pressure. Due to the construction of radial truck tires, particularly in the lower sidewall and bead area, it may be difficult to get the tire to take air. An inflation aid may be necessary to help seat the bead of tubeless radial tires. Two types of inflation aids are commercially available, (1) metal rings which use compressed air to seat beads, and (2) rubber rings which seal between the tire bead and rim bead seat allowing the bead to move out and seat. Lubrication is mandatory with both items.

4. Check bead seating. This check is made by measuring the space between the rim flange and one of the three lower sidewall rim line rings while the tire is laying flat (measurements should be taken each 90° around the circumference of the rim flange). If spacing is uneven around the bead from side to side, repeat Steps 1 through 3, and recheck.

It's important that this procedure be followed to insure proper bead seating in order to prevent bead deformation.

Radial tires, as well as the bias tires, must be mounted and inflated in accordance with safety precautions noted in RMA Radial and Bias Truck Tire Service Manuals.

### TIRE REPAIR

There are many different materials and techniques on the market to repair tires. As not all of these work on all types of tires, tire manufacturers have published detailed instructions on how and when to repair tires. These instructions can be obtained from the tire manufacturer.

### ALUMINUM WHEEL MAINTENANCE

Aluminum wheels can be cleaned, coated and painted using the following procedure. Care should be taken during entire procedure to avoid scratching or damaging the shiny aluminum surfaces.

#### Materials Required

1. Amercian Sure Seal paint remover, product STRIP OFF - stock SSQ or equivalent.
2. 360 grit sand paper.
3. Nylon auto glass type scraper.
4. Amercian Sure Seal Silicone Remover - stock DSR or 3M #8985 Wax Remover.
5. Paint thinners.
6. American Sure Seal Aluminum Cleaner - stock DWC or equivalent.
7. DuPont 228S conversion coating or equivalent.
8. Enamel color coat paint.
9. American Sure Seal Coricone 1700 Wheel Protector.
10. General purpose pads. 3M #7448 or equivalent.
11. American Sure Seal Glaze Cleaner - stock DGC or 3M #5979 clean and glaze.
12. American Sure Seal Wheel Polish - stock DAP or equivalent.

### PROCEDURE

1. Remove the wheel and tire assembly from the car. After marking the wheel-tire relationship, remove tire from wheel. If wheel and tire are not separated, mask off the tire prior to painting and

mark the weights and remove.

2. Using the general purpose pad and glaze cleaner, vigorously rub over the machine surface to remove corrosion and restore the luster of the bright machined surfaces on the wheel.
3. Wipe over the cleaned surface with the wheel polish to obtain maximum luster.
4. Using the silicone remover, clean the entire wheel. Wash off with clean water and air blow dry.

**CAUTION: USE OF RUBBER GLOVES AND EYE GOGGLES IS NECESSARY TO PREVENT PERSONAL INJURY.**

5. Using the "Strip Off " paint remover, spray the entire wheel surface with this product. Wait two to three minutes and then remove with a high pressure water hose.

Steps 6 through 12 are to be used only on aluminum wheels with painted surfaces.

6. If peeling or discoloration is extremely bad, it may be necessary to use the Strip Off more than once. Scrape off any loose paint with a nylon scraper and/or 360 grit sand paper.
7. Wipe entire wheel clean with the silicone remover and flush off again with water, followed by blow drying.
8. Mask off areas of wheel **not** to be painted.

9. Wipe over the painted surface with the aluminum cleaner, then apply the conversion coating, following label directions. (This is a two-step operation which will improve the adhesion of the primer.)
10. To ensure coverage in all areas, an application of zinc chromate primer should be applied to the wheel painted surface in four light applications, rotating the wheel 90°F (32°C) between applications.
11. Apply the color coat using the same procedure as for the primer.
12. After ten minutes of air drying, heat may be applied to the paint to reduce drying time.
13. When the color coat is completely dry, remove masking tape. Wheel must be perfectly clean of foreign material and dry before applying Coricone 1700, and clean the masked area with wax or silicone remover to eliminate tape residue.
14. Spray two light coatings of Coricone 1700 wheel protector on wheel allowing two or three minutes between coats. The clear coat will put an invisible coating on top of the painted surface and the polished aluminum.
15. **Do not** use heat on clear coat, allow to air dry for 24 hours.
16. Reinstall the tire and wheel (realign the index marks and/or the balance weight).

**WHEEL NUT TORQUES**

| Series  | Description                             | Torque       |         |
|---|---|--------------|---------|
|   |   | Ft. Lbs.     | N·m     |
| K   | 7/16" Bolts (6)                         | 90 Ft. Lbs.  | 120 N·m |
| C10, P10, G10, G20                                    | 1/2" Bolts (5)                          | 100 Ft. Lbs. | 140 N·m |
| C20, P20<br>C30, P30 and<br>K20, G30<br>Single Wheels | 9/16" Bolts (5)                         | 120 Ft. Lbs. | 160 N·m |
| CKPG30<br>Dual Wheels                                 | 9/16" Bolts (8)                         | 140 Ft. Lbs. | 190 N·m |
|   | Heavy Duty<br>Wheels<br>5/8" Bolts (10) | 200 Ft. Lbs. | 270 N·m |

## **SECTION 4**

# **CONTENTS**

### **PROPELLER SHAFT**

### **REAR AXLE**

**8-1/2" RING GEAR**

**9-1/2" RING GEAR**

**10-1/2" RING GEAR**

**10-1/2" RING GEAR (DANA)**

**9-3/4" RING GEAR (DANA)**

**12" RING GEAR (ROCKWELL)**

**LIMITED SLIP DIFFERENTIAL**

### **FRONT AXLE**

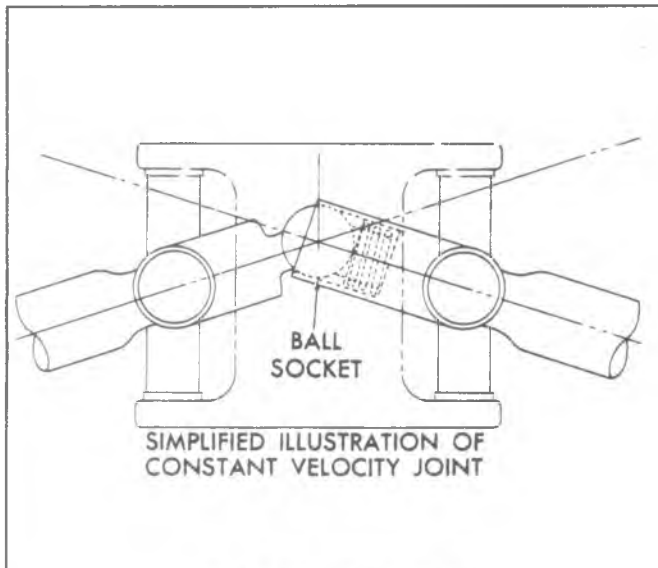

Fig. 3--Ball-Socket Location

The bearings used in universal joints are the needle roller type. The needle rollers are held in place on the trunnion by round bearing cups. The bearing cups are held in the yoke by either (depending on the manufacturer) snap rings or plastic injection. These joints usually are lubricated for life and cannot be lubricated while on the vehicle.

### Constant Velocity Joint-Double Cardan Joint

As mentioned previously, the simple universal joint will operate efficiently through small angles only. Also, two simple universal joints phased properly and operating through the same angle will transmit constant velocity. When a large angle is encountered in a driveline, a simple universal joint will introduce two vibrations in each revolution. It is in this situation that a constant velocity joint is used.

## PROPELLER SHAFT AND UNIVERSAL JOINT DIAGNOSIS

### PROPELLER SHAFT UNBALANCE

#### Checking and Correcting

1. Place vehicle on a twin post hoist so that the rear wheels are free to rotate.
2. Remove both rear tire and wheel assemblies and brake drums.  
Use care not to apply brakes with drums removed.
3. Visually inspect propshaft, U-Joints and attachments for mud undercoating or other discrepancies. Make necessary corrections prior to running.
4. With vehicle running in gear at the indicated speed where disturbance is at its peak, observe the intensity of the disturbance.
5. Stop engine and disconnect drive shaft from companion flange. Reinstall shaft by rotating it 180° from its original position. Determine which position of the companion flange gives the best balance.

Essentially, the constant velocity joint is two simple universal joints closely coupled by a coupling yoke, phased properly for constant velocity.

A centering ball socket between the joints maintains the relative position of the two units. This centering device causes each of the two units to operate through one-half of the complete angle between the drive shaft and differential carrier (Fig. 3).

The ball/socket on this Constant Velocity joint requires periodic lubrication. A lubrication fitting is provided for this purpose, and is illustrated later in this section.

### Propeller Shafts

The propeller shaft is a steel tube which is used to transmit power from the transmission output shaft to the differential. To accommodate various model, wheelbase and transmission combinations, drive shafts differ in length, diameter and the type of splined yoke. Each shaft is installed in the same manner. A universal joint and splined slip yoke are located at the transmission end of the shaft, where they are held in alignment by a bushing in the transmission rear extension. The slip yoke permits fore and aft movement of the drive shaft as the differential assembly moves up and down. The spline is lubricated internally by transmission lubricant or grease. An oil seal at the transmission prevents leakage and protects the slip yoke from dust, dirt and other harmful material.

Since the drive shaft is a balanced unit, it should be kept completely free of undercoating and other foreign material which would upset shaft balance.

Both one piece and two piece propeller shafts are used depending on the model. All are tubular and use needle bearing type universal joints.

On models that use a two piece shaft, the shaft is supported near its splined end in a rubber cushioned ball bearing which is mounted in a bracket attached to a frame crossmember. The ball bearing is permanently lubricated and sealed.

Four wheel drive models use a front propeller shaft incorporating a constant velocity joint.

6. Install rear drums and wheels, and road test vehicle for final check of balance. If balance is still unacceptable, replace drive shaft.

### CHECKING PROPELLER SHAFT RUN-OUT

If a noise or vibration is present at high speed which might be caused by a bent shaft, or if a shaft has been damaged through rough handling or a collision, it may be checked for straightness as follows:

1. Raise vehicle on a twin post hoist so that the rear is supported on the rear axle housing with wheels free to rotate.
2. Mount a dial indicator on a movable support that is high enough to permit contact of the indicator button with the propeller shaft, or mount dial indicator to a magnetic base and attach to a suitable smooth place on the underbody of the vehicle. Readings are to be

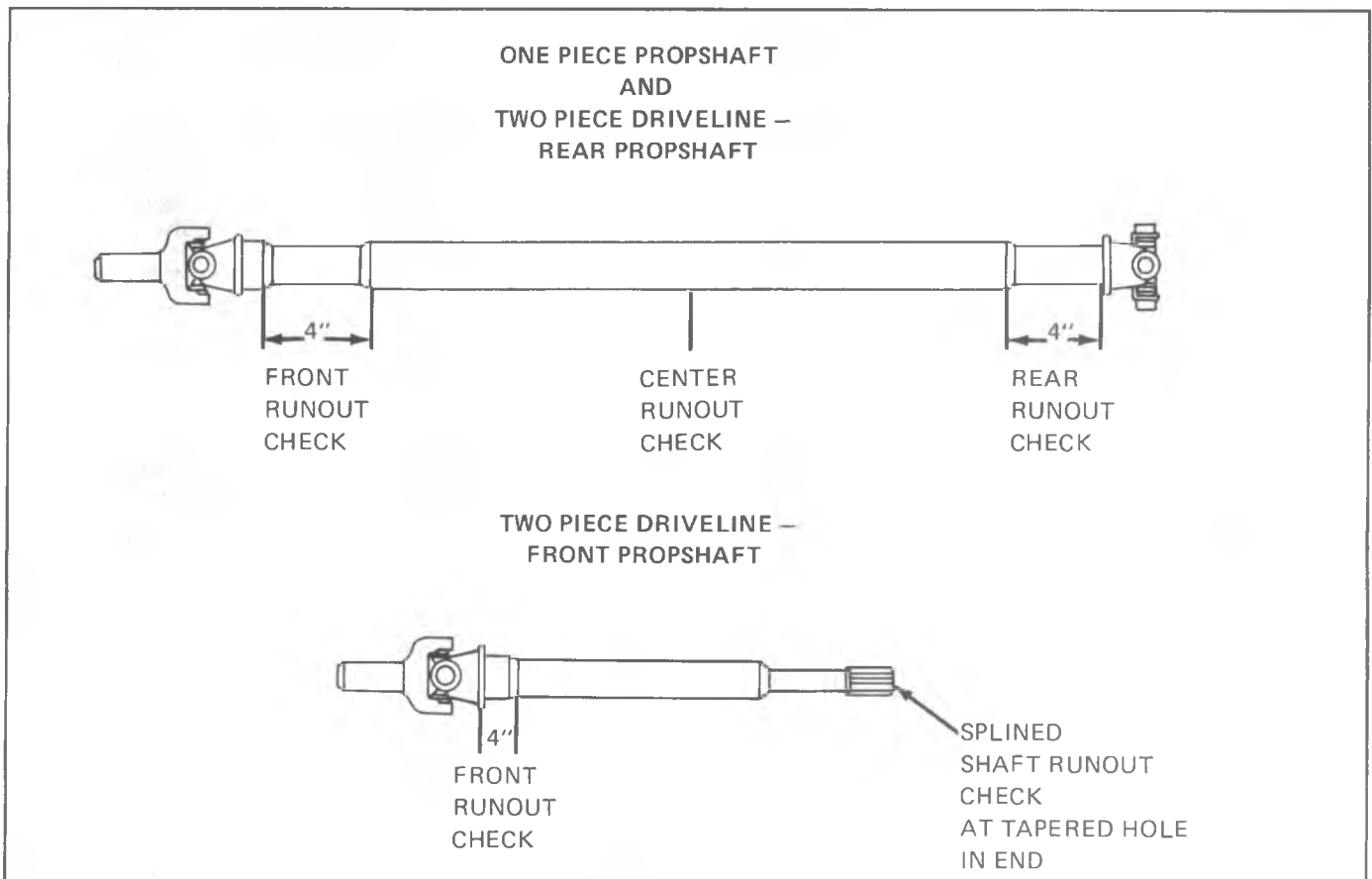

Fig. 4--Checking Prop Shaft Runout

taken at points indicated in Figure 4.

3. With transmission in neutral, check runout by

| PROPELLER SHAFT | FRONT | CENTER | REAR   |
|-----------------|-------|--------|--------|
| ONE PIECE       | .040  | .050   | .055   |
| TWO PIECE FRONT | .020  |        | .008 Δ |
| TWO PIECE REAR  | .030* | .030   | .035   |

Δ NOTE: This measurement must be taken at center of splined shaft after rear prop shaft is removed.

\* NOTE: This measurement must be taken with rear shaft mounted on front shaft which is within specifications.

Fig. 5--Runout Specifications

rotating the axle pinion flange or transmission yoke.

On models with One-Piece Propshaft, measure runouts at front-center-rear on tube. Refer to Fig. 4.

On models with Two-Piece Propshaft, measure runouts on rear shaft at front-center-rear on its tube. Then, index position of rear propshaft in pinion flange and remove rear propshaft. Measure runouts of front propshaft at front on tube and at rear in tapered hole on end of splined shaft.

**NOTICE:** The runout of splined shaft is critical to smooth operation of Two-Piece Driveline. If this runout exceeds specifications, the front propshaft must be replaced.

Care must be taken not to include indicator variation caused by surface contamination, ridges, flat spots, or other variations in the tube.

4. If runout exceeds specifications, rotate the shaft 180° at companion flange and reinstall. Check runout again.
5. If runout is still over specifications at one or more locations, replace the drive shaft, but only after checking vibration or noise, replacement must be rechecked for runout also.
6. If the new drive shaft runout is still over specifications, check for a bent companion flange.

| COMPLAINT  | POSSIBLE CAUSE   | CORRECTION  |
|--|--|---|
| <p>Leak at front slip yoke.</p> <p><b>NOTE:</b> An occasional drop of lubricant leaking from splined yoke is normal and requires no attention.</p>                             | <p>a. Rough outside surface on splined yoke.</p> <p>b. Defective transmission rear oil seal.</p>               | <p>a. Replace seal if cut by burrs on yoke. Minor burrs can be smoothed by careful use of crocus cloth or honing with a fine stone. Replace yoke if outside surface is rough or burred badly.</p> <p>b. Replace transmission rear oil seal.</p> <p>c. Bring transmission oil up to proper level after correction.</p> |
| <p>Knock in drive line, clunking noise when car is operated under floating condition at 10 mph in high gear or neutral.</p>  | <p>a. Worn or damaged universal joints.</p> <p>b. Side gear hub counterbore in differential worn oversize.</p> | <p>a. Disassemble universal joints, inspect and replace worn or damaged parts.</p> <p>b. Replace differential case and/or side gears as required.</p>   |
| <p>Ping, Snap or Click in drive line.</p> <p><b>NOTE:</b> Usually occurs on initial load application after transmission has been put into gear, either forward or reverse.</p> | <p>a. Loose upper or lower control arm bushing bolts.</p> <p>b. Loose companion flange.</p>                    | <p>a. Tighten bolts to specified torque.</p> <p>b. Remove companion flange, turn 180° from its original position, apply white lead to splines and reinstall. Tighten pinion nut to specified torque.</p>  |

Fig. 6--Diagnosis Chart A



| COMPLAINT  | POSSIBLE CAUSE   | CORRECTION  |
|--|--|---|
| <p>Roughness, Vibration or Body Boom at any speed.</p> <div style="border: 1px solid black; padding: 5px;"> <p>NOTE: With tachometer installed in vehicle, determine whether propeller shaft is cause of complaint by driving through speed range and note the engine speed (rpm) at which vibration (roughness) is most pronounced. Then, shift transmission to a different gear range and drive vehicle at same engine speed (rpm) at which vibration was noted before. Note the effect on the vibration in each transmission gear range.</p> <p>If vibration occurs at the same engine speed (rpm) regardless of transmission gear range selected, drive shaft assembly is not at fault, since the shaft speed (rpm) varies.</p> <p>If vibration decreased, or is eliminated, in a different gear range but at the same engine speed (rpm), check the possible causes:</p> </div> | <ul style="list-style-type: none"> <li>a. Bent or dented drive shaft.</li> <li>b. Undercoating on drive shaft.</li> <li>c. Tire unbalance. (30-80 mph, not throttle conscious)</li> <li>d. Worn universal joints.</li> <li>e. Burrs or gouges on companion flange. Check snap ring locating surfaces on flange yoke.</li> <li>f. Excessive drive shaft or companion flange unbalance, or runout.</li> <li>g. Excessive looseness at slip yoke spline.</li> <li>h. Drive shaft runout (50-80 mph throttle conscious)</li> </ul> | <ul style="list-style-type: none"> <li>a. Replace.</li> <li>b. Clean drive shaft.</li> <li>c. Balance or replace as required. *</li> <li>d. Overhaul, replacing necessary parts.</li> <li>e. Rework or replace companion flange.</li> <li>f. Check for missing balance weights on drive shaft. Remove and reassemble drive shaft to companion flange, 180° from original position.</li> <li>g. Replace necessary parts.</li> <li>h. Check drive shaft runout at front and rear. Should be less than specified. If above, rotate shaft 180° and recheck. If still above specified, replace shaft.</li> </ul> |
| <p>Scraping noise.</p>   | <ul style="list-style-type: none"> <li>a. Slinger, companion flange, or end yoke rubbing on rear axle carrier.</li> </ul>  | <ul style="list-style-type: none"> <li>a. Straighten slinger to remove interference.</li> </ul>   |
| <p>Roughness — above 35 mph felt and/or heard.</p>   | <ul style="list-style-type: none"> <li>a. Tires unbalanced or worn.</li> </ul>   | <ul style="list-style-type: none"> <li>a. Balance or replace as required.</li> </ul>  |
| <p>*NOTE: Out-of-round tires cannot be corrected with balance weights. If vehicle disturbance remains after tire balance, recheck with rear wheels and tires and brake drums removed.</p>  |  |   |

Fig. 7--Diagnosis Chart B

## ON VEHICLE SERVICE

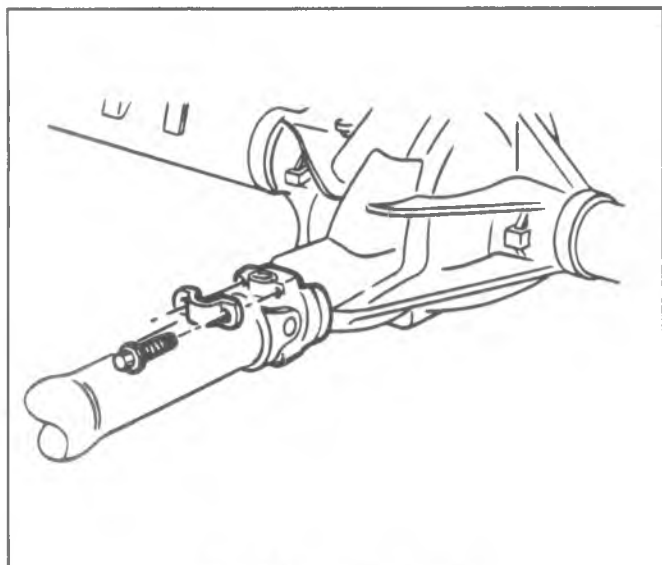

Fig. 8--Strap Attachment

### PROPELLER SHAFT (REAR DRIVE)

The rear universal joint to propshaft bolt on some models requires a #10 "Six Lobed Socket" (J-33051), for proper removal and installation.

#### Removal

**NOTICE:** Do not pound on original propeller shaft yoke ears as injection joints may fracture.

1. Raise vehicle on hoist. Mark relationship of shaft to pinion flange and disconnect the rear universal joint by removing retainers. If bearing cups are loose, tape together to prevent dropping and loss of bearing rollers.
2. For models with two-piece shafts, remove bolts retaining center bearing support to hanger and disconnect grease seal and cap.
3. Slide propeller shaft forward disengaging trunnion from axle flange.
4. Withdraw propeller shaft slip yoke from transmission by moving shaft rearward, passing it under the axle housing. Do not allow drive shaft to drop or allow universal joints to bend to extreme angle, as this might fracture injected joint internally. Support propeller shaft during removal.

#### Installation

Inspect for the following conditions before reinstalling propeller shaft.

- Inspect outer diameter of splined yoke to ensure that it is not burred, as this will damage the transmission seal.
- Inspect splines of slip yoke for damage or wear.

The propeller shaft must be supported carefully during handling to avoid jamming or damaging any of the parts. Do not drive propeller shaft in place with hammer. Check for burrs on transmission output shaft spline, twisted slip yoke splines, or possibly the wrong U-joint yoke. Make sure the

splines agree in number and fit. To prevent trunnion seal damage, do not place any tool between yoke and U-joint.

### One Piece Propeller Shaft

1. Slide propeller shaft into transmission.
2. Position rear universal joint to rear axle pinion flange, making sure bearings are properly seated in pinion flange yoke.

When making rear shaft connection, be sure to align mark on pinion flange with mark on drive shaft rear yoke.

3. Install rear joint fasteners and tighten evenly to torque specified.

### Two Piece Propeller Shaft

1. Install front half into transmission and bolt center bearing support to crossmember.

The front propeller shaft yoke must be bottomed out in the transmission (fully forward) before installation to the support.

2. Torque center support bearing to crossmember attachment. Maintain alignment as shown in Fig. 10.
3. Rotate front propshaft, locate the "bridged" teeth on its output spline, and position at bottom-most (i.e. 6:00) position. Then, find missing tooth in slip yoke, and position yoke to slide over bridged teeth on front shaft.
4. Position rear U-joint to rear axle pinion flange, making sure bearings are properly seated in pinion flange yoke. When making rear shaft connection, be sure to align mark on pinion flange with mark on propshaft.
5. Install rear joint retainers and fasteners and tighten evenly to specified torque.
6. Attach seal and grease cap to center slip yoke. Tighten firmly.

### PROPELLER SHAFT (FRONT)

#### Removal

**NOTICE:** Do not pound on original proeller shaft ears as injection joints may fracture.

1. Raise vehicle on hoist. Make relationship of shaft to front axle and transfer case flanges. Disconnect front U-Joints by removing retainers. Remove bolts at transfer case.
2. Collapse propshaft sufficiently to disengage front U-Joint from front axle.
3. Withdraw propshaft by moving shaft rearward between transfer case. Handle propshaft with care to avoid dropping cap assemblies from yoke ends of U-Joint. Wrap tape around loose caps, if required to hold them in position.

#### Installation

Inspect for the following conditions before reinstalling propeller shaft:

- Inspect slip yoke splines for damage or wear.
- Inspect propeller shaft for burrs on splines or twisted splines.

The propeller shaft must be supported and carefully handled to avoid jamming or damaging any of the parts. Do

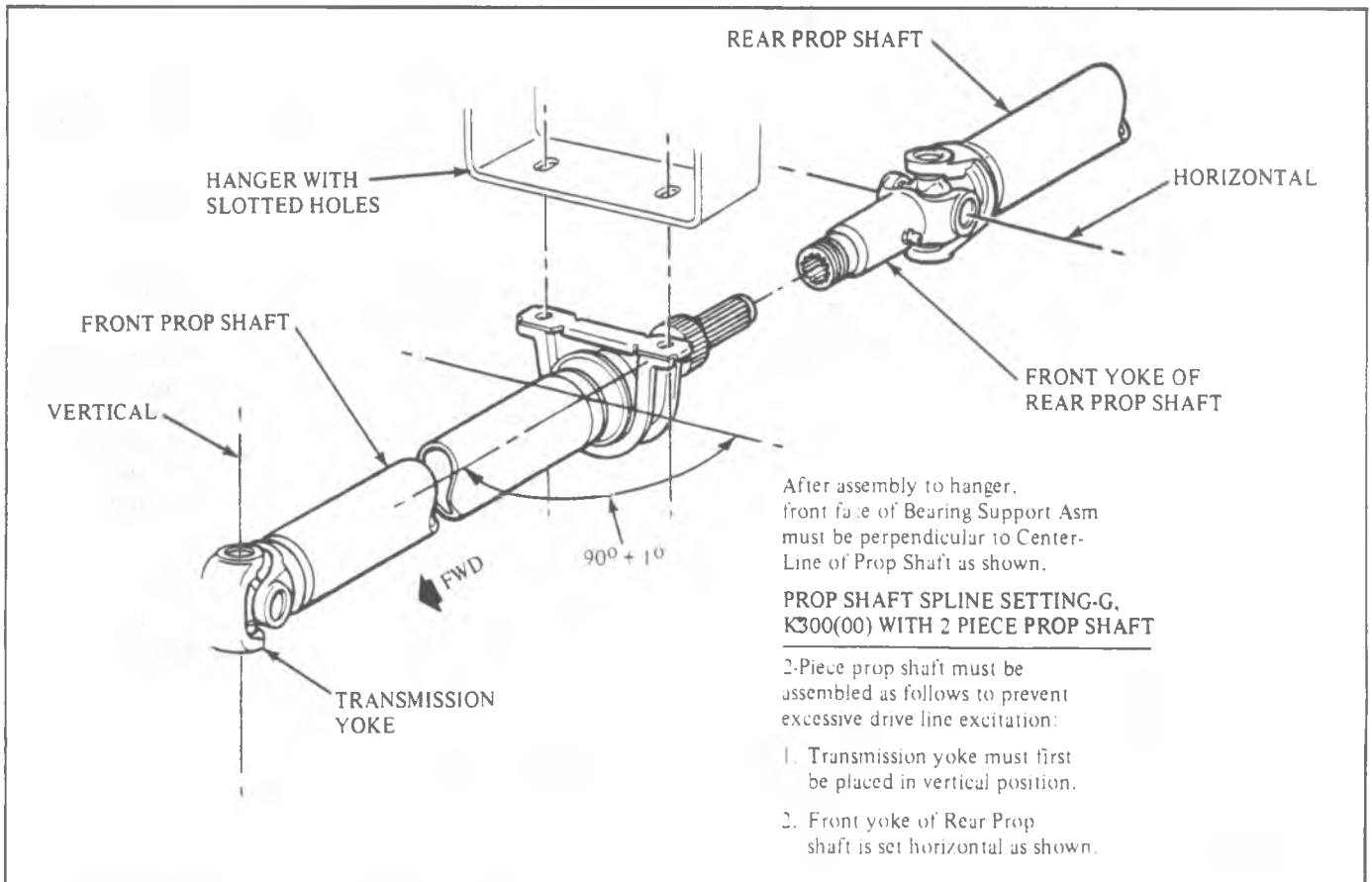

Fig. 10--Alignment For Phasing

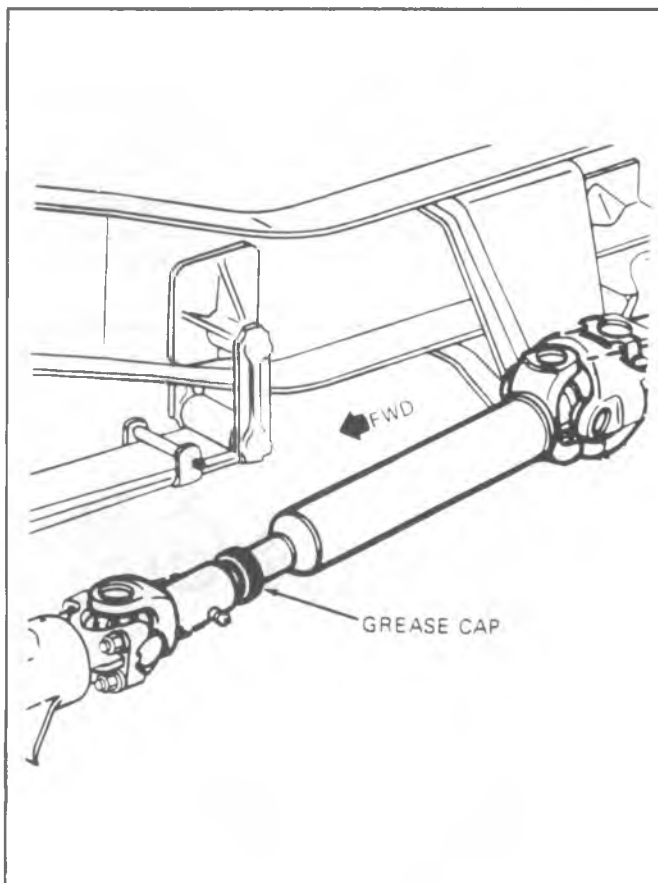

Fig. 9 -- Proper Alignment

not drive propeller shaft in place with a hammer. To prevent possible trunnion seal damage, do not place any tool between U-Joint and yoke.

1. Extend propshaft to full length, then compress it about half of its stroke.
2. Slide slip yoke end of propshaft towards front axle, fitting U-Joint caps within span of tabs on flange.
3. Install retainers and bolts and tighten evenly. U-Joint caps will draw into tabs if they are positioned on inside chamfer of tab, and retainers are tighten uniformly.
4. Torque bolts at front axle to specified amount.
5. Extend propshaft until it fits against transfer case flange.
6. Install bolts and tighten evenly.
7. Torque bolts at transfer case to specified amount.

On models with between center slip propshaft it is important that components are marked prior to disassembly for proper phasing.

## UNIT REPAIR

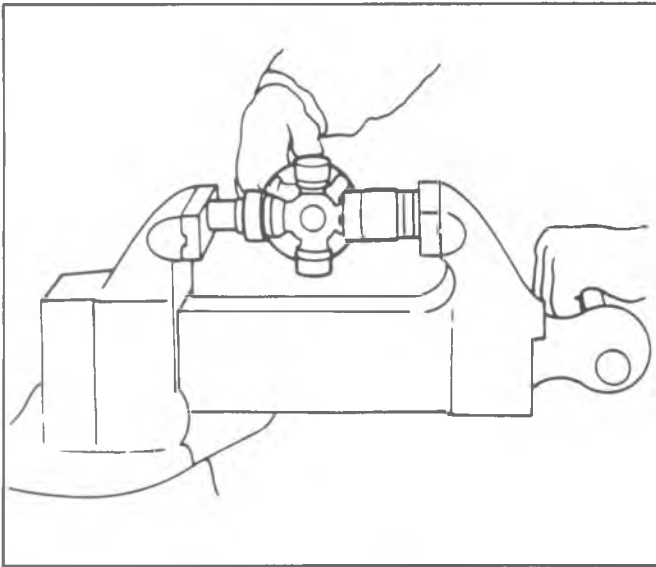

Fig. 11--Bearing Cup Removal with Vise

### UNIVERSAL JOINTS

The universal joints are of the extended-life design and do not require periodic inspection or lubrication; however, when these joints are disassembled, repack bearings and lubricate reservoir at end of trunnions with high-melting point wheel bearing lubricant. Use care not to damage or dislodge seals from trunnion.

#### Snap Ring Type

##### Disassembly

1. Remove bearing lock rings from trunnion yoke.
2. Support trunnion yoke on a piece of 31.75 mm (1-1/4") I.D. pipe on an arbor bed.

Due to length of the propeller shaft it may be more convenient to use a bench vise, for removal and installation, instead of an arbor press. In this case, proceed with disassembly and assembly procedure as with an arbor press Figs. 11 and 12.

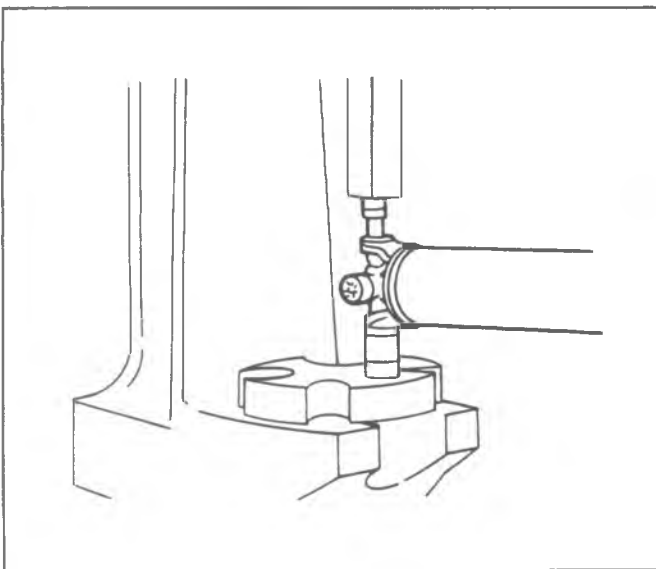

Fig. 12--Bearing Cup Removal with Press

3. Using a suitable socket or rod, press on trunnion until bearing cup is almost out. Grasp cup in vise and work cup out of yoke (Figs. 11 and 12). The bearing cup cannot be fully pressed out.
4. Press trunnion in opposite direction and remove other cup as in Step 3.
5. Clean and inspect dust seals, bearing rollers, and trunnion. Relubricate bearings as indicated in Maintenance and Lubrication Section.

In addition to packing the bearings, make sure that the lubricant reservoir at the end of each trunnion is filled with lubricant. In filling these reservoirs, pack lubricant into the hole so as to fill from the bottom (use of squeeze bottle is recommended). This will prevent air pockets and ensure an adequate supply of lubricant.

##### Reassembly (Fig. 13)

1. Position trunnion into yoke. Partially install one bearing cup into yoke. Start trunnion into bearing cup. Partially install other cup. Align trunnion into cup, and press cups into yoke.
2. Install lock rings.

### Injected Plastic Type

##### Disassembly

**NOTICE:** Never clamp drive shaft tubing in a vise as the tube may be dented. Always clamp on one of the yokes, and support the shaft horizontally. Avoid damaging the slip yoke sealing surface. Nicks may damage the bushing or cut the seal lip.

1. Support the drive shaft in a horizontal position in line with the base plate of a press. Place the universal joint so that the lower ear of the shaft yoke is supported on a 28.57 mm (1-1/8") socket. Place the cross press, J-9522-3, on the open horizontal bearing cups, and press the lower bearing cup out of the yoke ear as shown in Fig. 14. This will shear the plastic retaining the lower bearing cup.

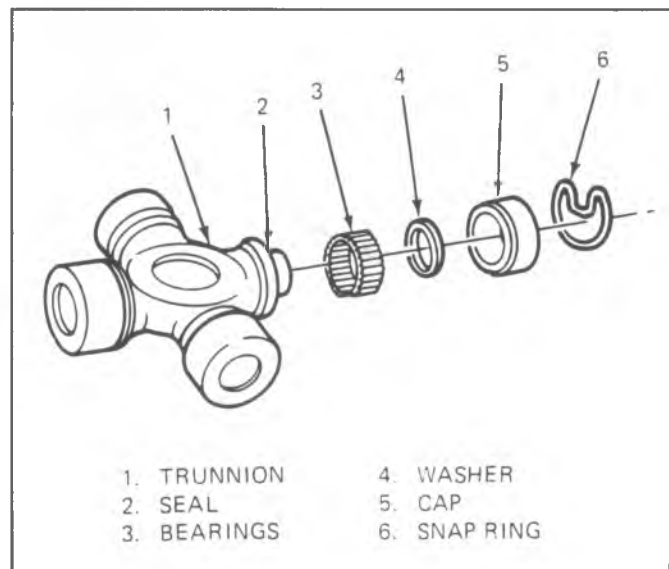

Fig. 13--Universal Joint Repair Kit

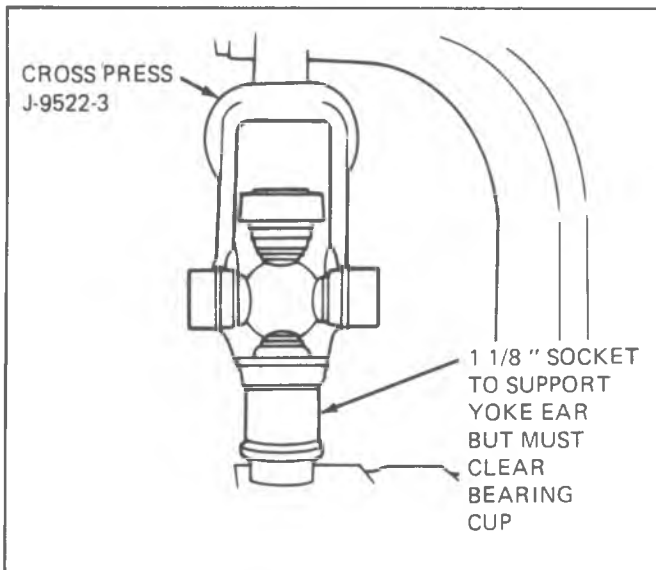

Fig. 14 -- Pressing Out Bearing Cup

2. If the bearing cup is not completely removed, lift the cross and insert Spacer J-9522-5 between the seal and bearing cup being removed, as shown in Fig. 15. Complete the removal of the bearing cup, by pressing it out of the yoke.
3. Rotate the drive shaft, shear the opposite plastic retainer, and press the opposite bearing cup out of the yoke as before, using Spacer J-9522.
4. Disengage cross from yoke and remove. Production universal joints cannot be reassembled. There are no bearing retainer grooves in production bearing cups. Discard all universal joint parts removed.
5. Remove the remains of the sheared plastic bearing retainer from the ears of the yoke. This will aid in reassembly of the service joint bearing cups. It usually is easier to remove plastic if a small pin or punch is first driven through the injection holes.
6. If the front universal joint is being serviced,

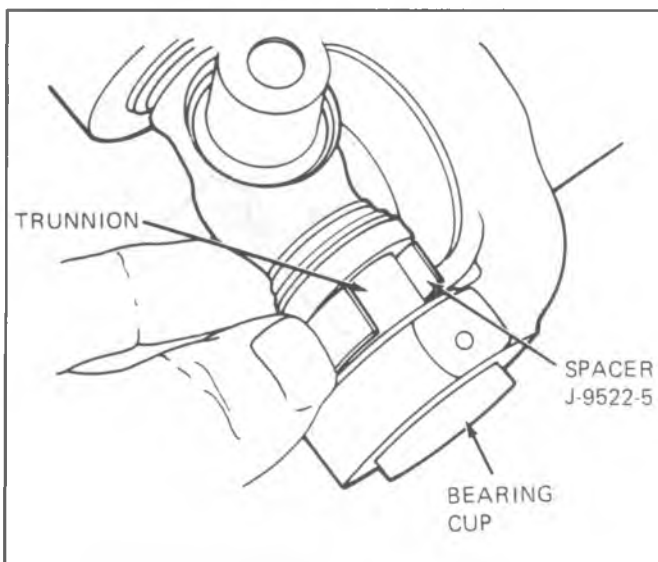

Fig. 15--Using Spacer to Remove Bearing Cup

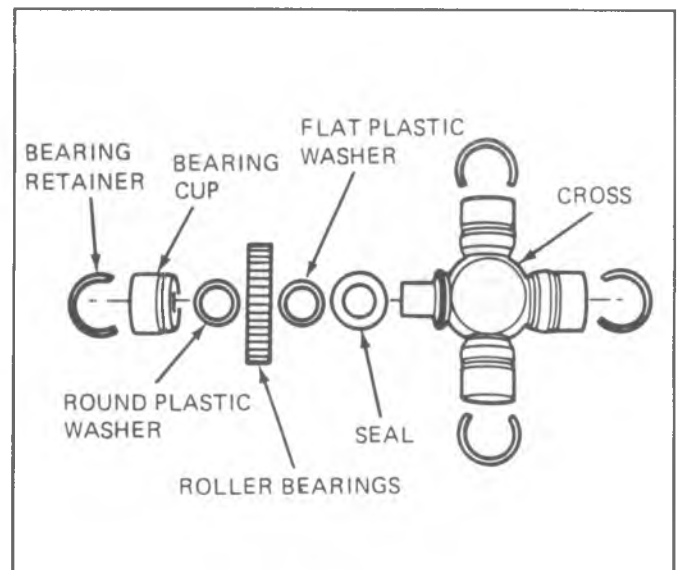

Fig. 16--Repair Kit

remove the pair of bearing cups from the slip yoke in the same manner.

**Reassembly**

A universal joint service kit (Fig. 16) is used when reassembling this joint. This kit includes one pregreased cross assembly, four service bearing cup assemblies with seals, needle rollers, washers, grease and four bearing retainers.

Make sure that the seals are in place on the service bearing cups to hold the needle rollers in place for handling.

1. Remove all of the remains of the sheared plastic bearing retainers from the grooves in the yokes. The sheared plastic may prevent the bearing cups from being pressed into place, and this will prevent the bearing retainers from being properly seated.
2. Install one bearing cup part way into one side of the yoke, and turn this yoke ear to the bottom.
3. Insert cross into yoke so that the trunnion seats freely into bearing cup as shown in Fig. 17.

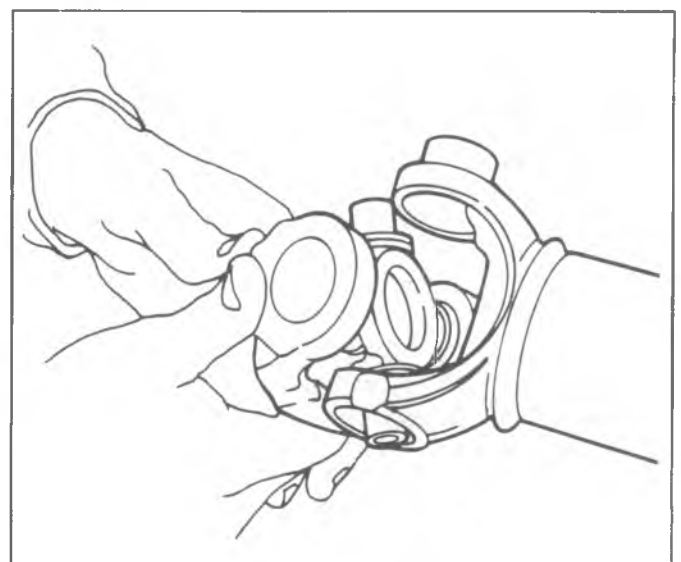

Fig. 17--Installing Trunnion into Yoke

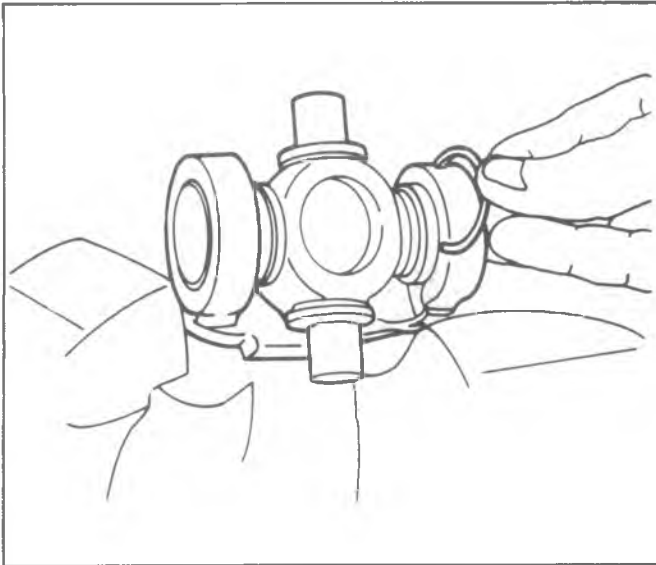

Fig. 18--Installing Snap Ring to Retain Trunnion

4. Install opposite bearing cup part way. Make sure that both trunnions are started straight and true into both bearing cups.
5. Press against opposite bearing cups, working the cross all of the time to check for free movement of the trunnions in the bearings. If there seems to be a hang-up, stop pressing and recheck needle rollers, to determine if one or more of them has been tipped under the end of the trunnion.
6. As soon as one bearing retainer groove clears the inside of the yoke, stop pressing and snap the bearing retainer into place as shown in Fig. 18.
7. Continue to press until the opposite bearing retainer can be snapped into place. If difficulty is encountered, strike the yoke firmly with a hammer to aid in seating bearing retainers (Fig. 19). This springs the yoke ears slightly.
8. Assemble the other half of the universal joint in the same manner.
9. Check the freedom of rotation of both sets of trunnions of the cross. If too tight, again rap the yoke ears as described above. This will loosen the bearings and help seat the bearing retainers.

### CENTER SUPPORT BEARING-FIG (FIG. 20)

**NOTICE:** See NOTICE on page 1 of this section regarding Center Support Bearing fasteners.

1. Remove strap retaining rubber cushion from bearing support.
2. Pull support bracket from rubber cushion and pull cushion from bearing.
3. Pull bearing assembly from shaft.
4. Assemble bearing support as follows:
  - a. Install inner deflector on propeller shaft, if removed, and prick punch deflector at two opposite points to make sure it is tight on shaft. b. Fill space between inner dust shield and bearing with lithium soap grease.
  - c. Start bearing and slinger assembly straight on shaft journal. Support propeller shaft and, using suitable

length of pipe over splined end of shaft, press bearing and inner slinger against shoulder on shaft.

- d. Install dust shield over shaft, small diameter. Install bearing retainer.
- e. Install rubber cushion onto bearing.
- f. Install bracket onto cushion.
- g. Install retaining strap.

### Installation of Propshafts

**NOTICE:** When reinstalling propshafts, it is necessary to place the shafts into particular positions to assure proper operation. This is called phasing. **All models with 32 splines** use an alignment key, as shown in Fig. 21, to obtain proper phasing. The shafts can mate only in the correct position. **G and K models with 16 splines** must be phased as shown in figure 10.

1. For models with one piece propeller shafts, slide shaft into transmission and attach rear U-joint to axle.

On C models, equipped with automatic transmission and one piece shaft only, apply a small amount (approximately 18 grams) of lubricant P/N 9985038 inside the slip yoke before installing propshaft.

*On vehicles with two piece propshafts, the front propshaft yoke must be bottomed out in the transmission fully forward before installation to the hanger.*

2. For C-P and most G models with two-piece propeller shafts, proper phasing is accomplished with the alignment key, shown in Fig. 21.
3. For G-K models with two piece shafts, install front half into transmission and bolt support to crossmember.
  - a. Slide grease cap and gasket onto rear splines.
  - b. Rotate shaft so front U-joint trunnion is in correct position (Fig. 10).
  - c. Take rear propeller shaft and before installing, align U-joint trunnions as shown in Fig. 10. Attach rear U-joint to axle and then tighten grease cap on shaft. Tighten grease cap.
  - d. Torque bearing support to crossmember and U-joint to axle attachments.

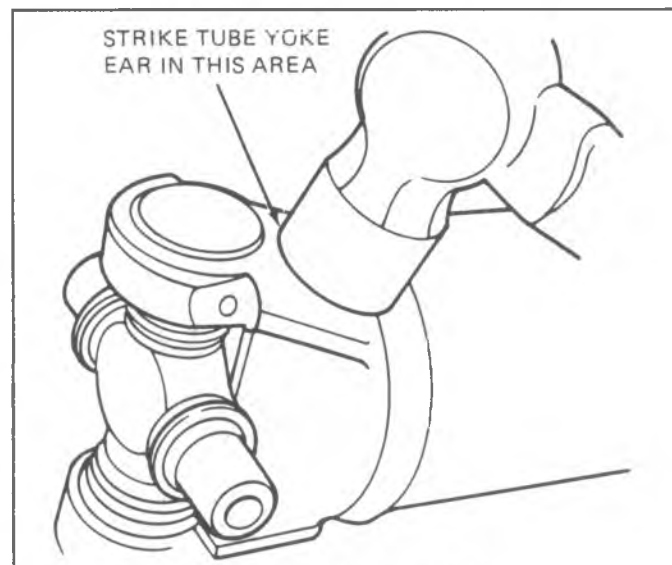

Fig. 19--Seating Snap Rings

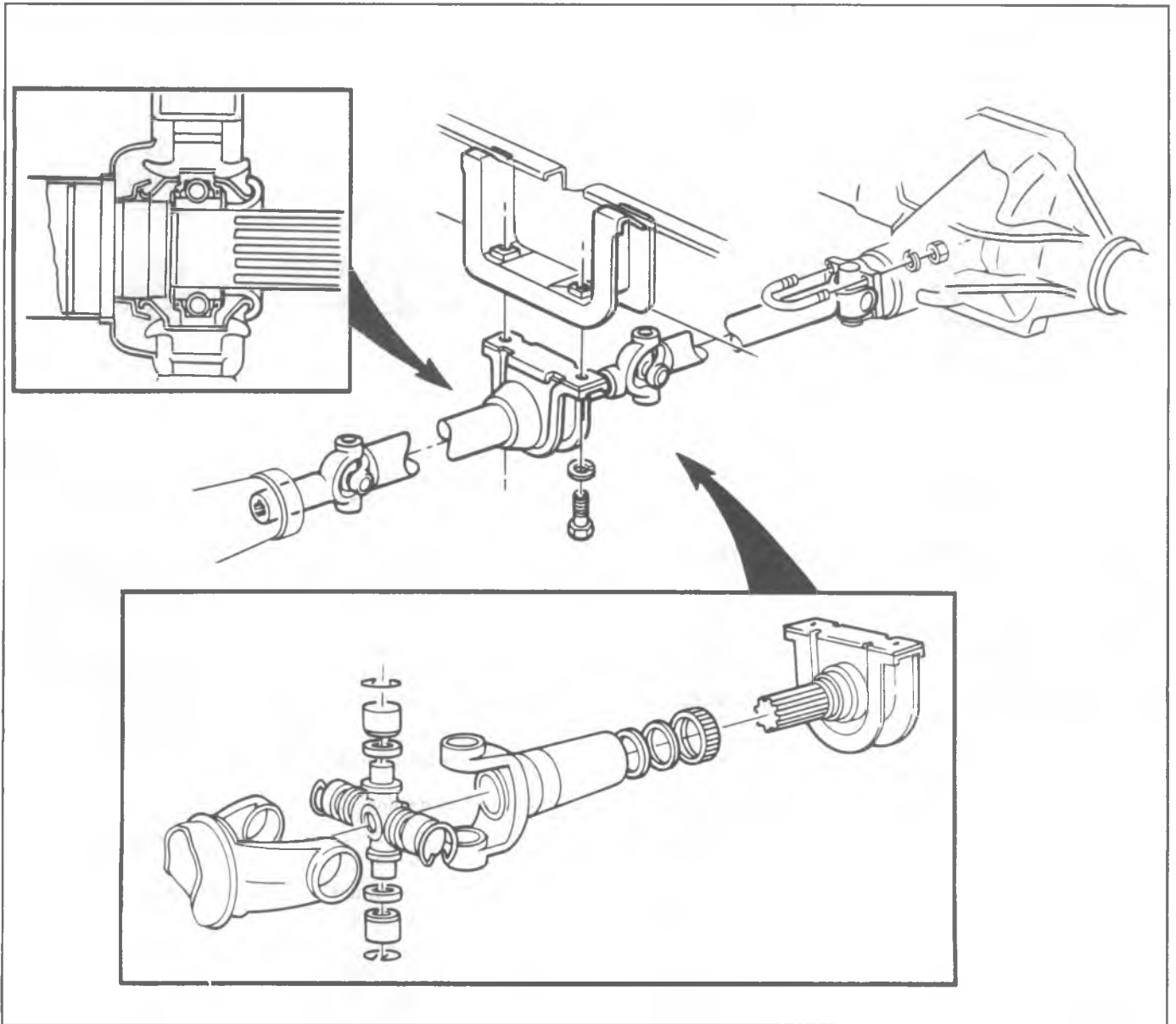

Fig. 20--Propeller Shaft, Universal Joint and Bearing Support

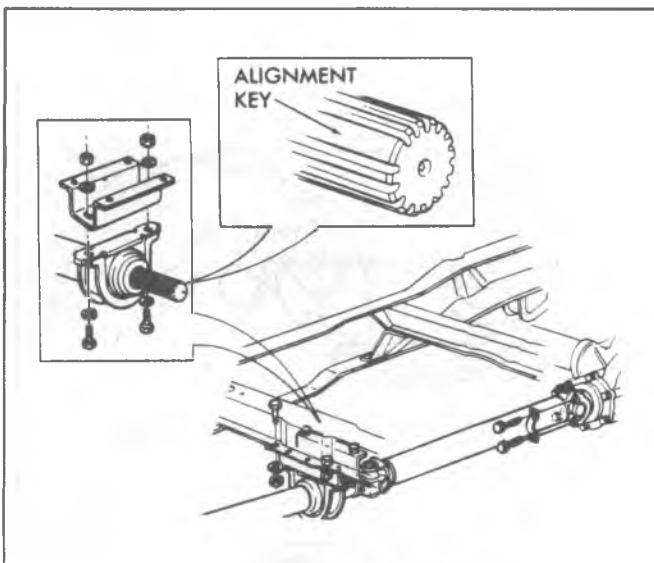

Fig. 21--Alignment Key

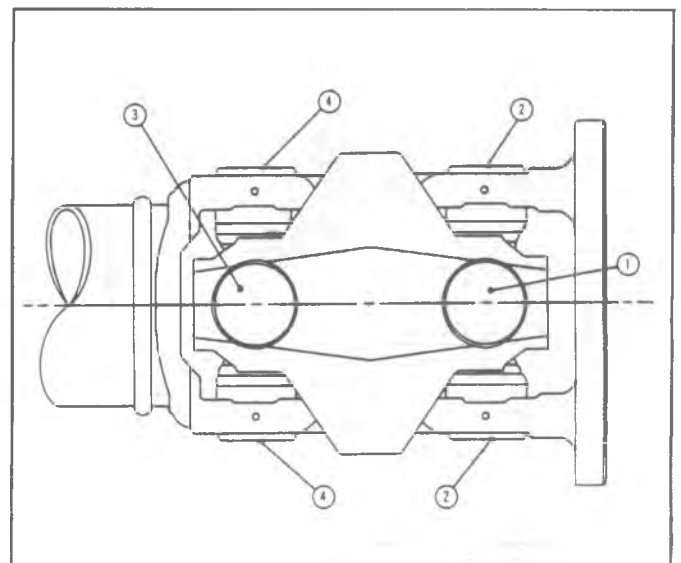

Fig. 22--Bearing Cap Removal Sequence

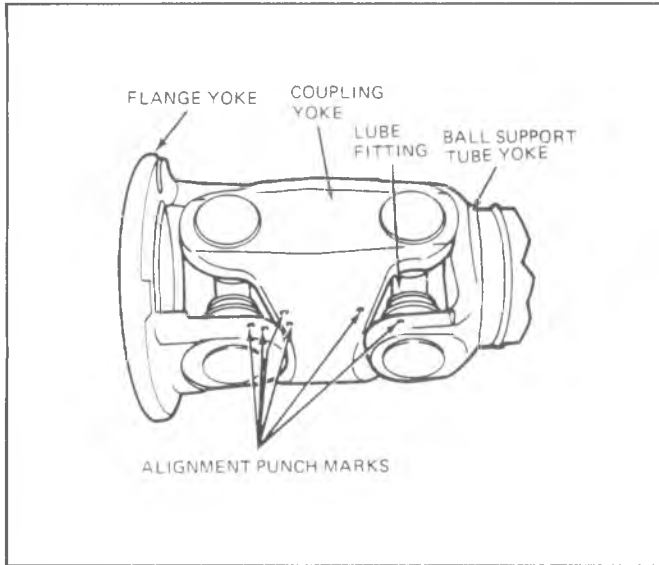

Fig. 23--Reassembling Coupling Yoke

### CONSTANT VELOCITY UNIVERSAL JOINT

#### Inspection

An inspection kit including two bearing caps and two snap rings is available to allow the removal of the two trunnion caps shown at location 1, in Fig. 22. **Mark the flange yoke and coupling yoke for reassembly in the same position, as shown in Fig. 23.**

To service the trunnion caps, use the appropriate procedures given in the beginning of this Section.

When both bearing cups are free, disengage the flange yoke and trunnion from the centering ball. Note that the ball socket is part of the flange yoke assembly, while the centering ball is pressed onto a stud and is part of the ball stud yoke (Fig.24). Pry the seal from the ball socket and remove washers, spring and the three ball seats as illustrated in Fig. 25.

1. Clean and inspect ball seat insert bushing for wear. If bushing is worn, replace flange yoke and cross assembly.

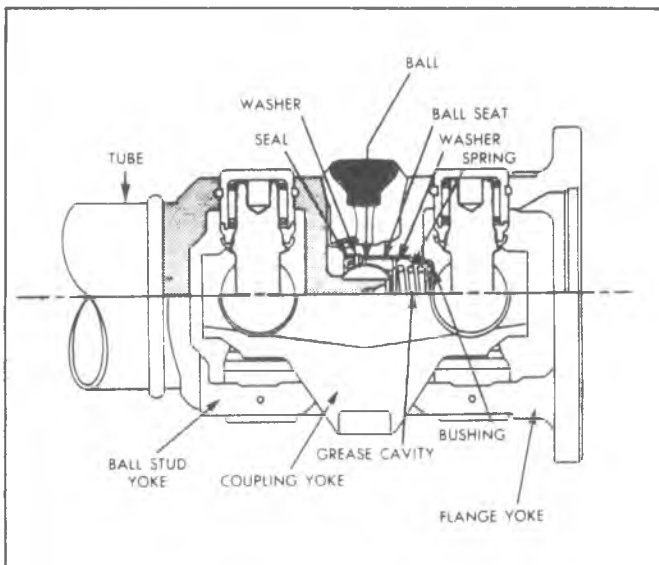

Fig. 24--Cross Sectional View of CV Joint

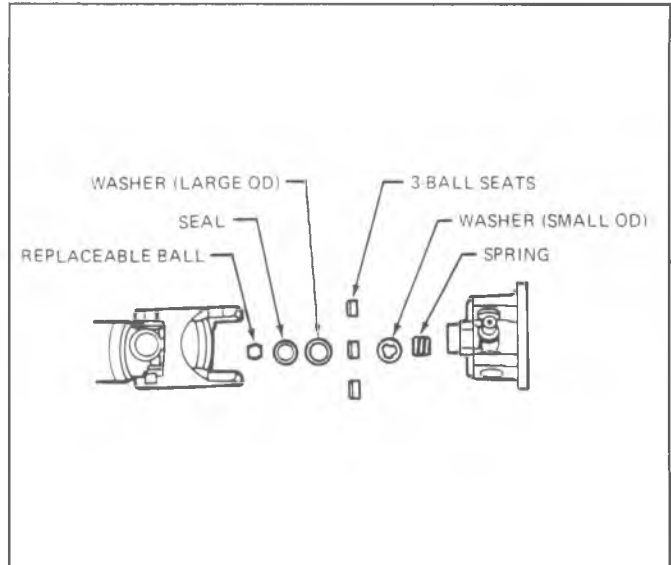

Fig. 25--Exploded View of Centering Ball Mechanism

2. Clean and inspect seal and ball seats along with spring and washers. If any parts show indication of excessive wear or are broken, replace the entire set with a service kit.

Whenever the seal is removed to inspect ball seat parts, it should be discarded and replaced with a new seal.

3. Remove all plastic from groove of coupling yoke.
4. Inspect the centering ball surface. If it shows signs of wear beyond smooth polish, replace it.

#### Centering Ball Replacement

1. Place fingers of inner part of Tool J-23996 under ball as shown in Fig. 26.
2. Place outer cylinder of Tool J-23996 over outside of ball as shown in Fig. 27.
3. Thread nut on Tool J-23996 and draw ball off stud, using wrench as shown in Fig. 29.
4. Place the replacement ball on stud.
5. Using Tool J-23996, drive ball onto stud as in Fig.

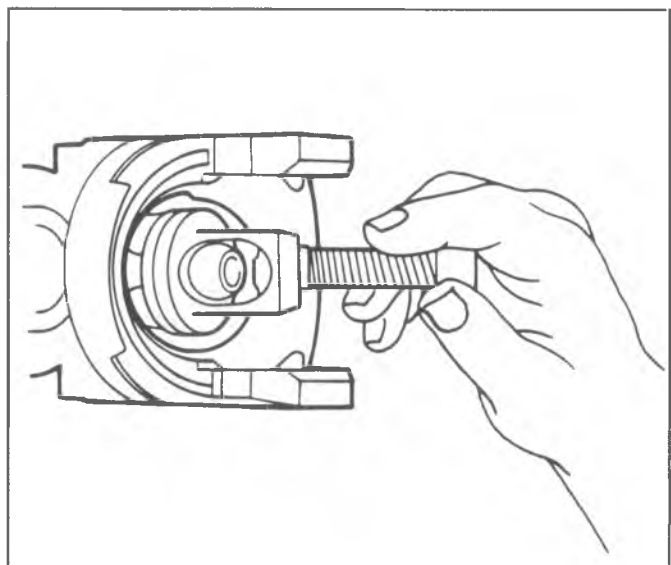

Fig. 26--Installing Tool J-23996 Over Ball



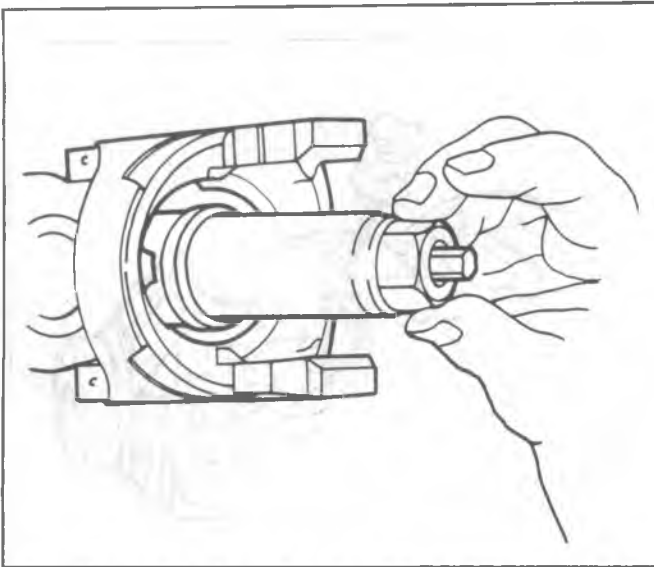

Fig. 27--Installing Outer Cylinder of Tool J-23996 Over Ball

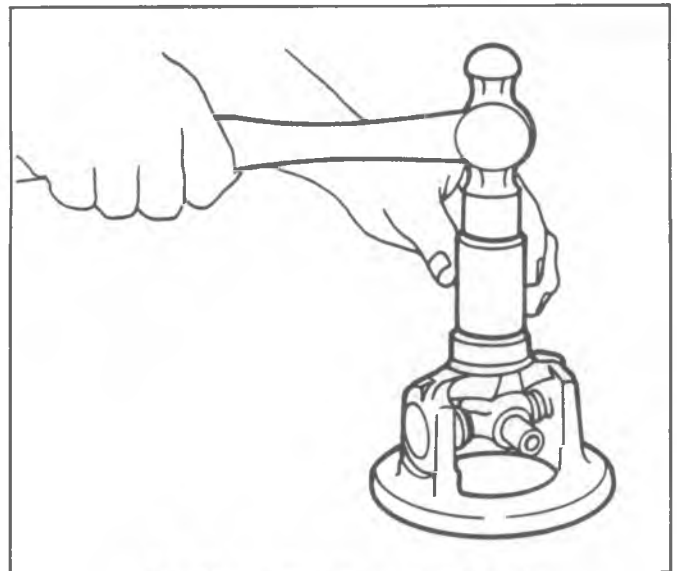

Fig. 30--Installing Centering Ball Seal

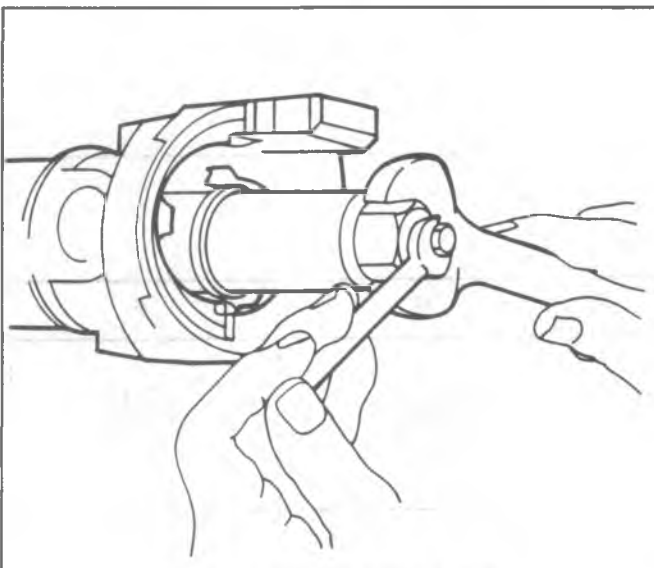

Fig. 28--Removing Centering Ball

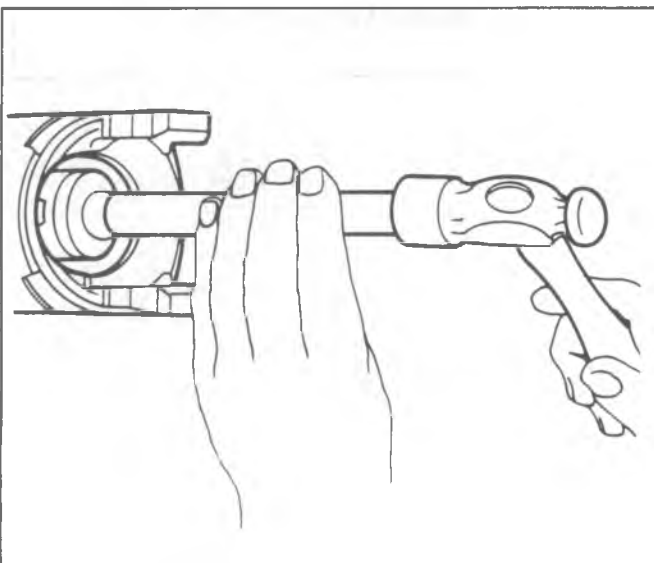

Fig. 29--Installing Centering Ball

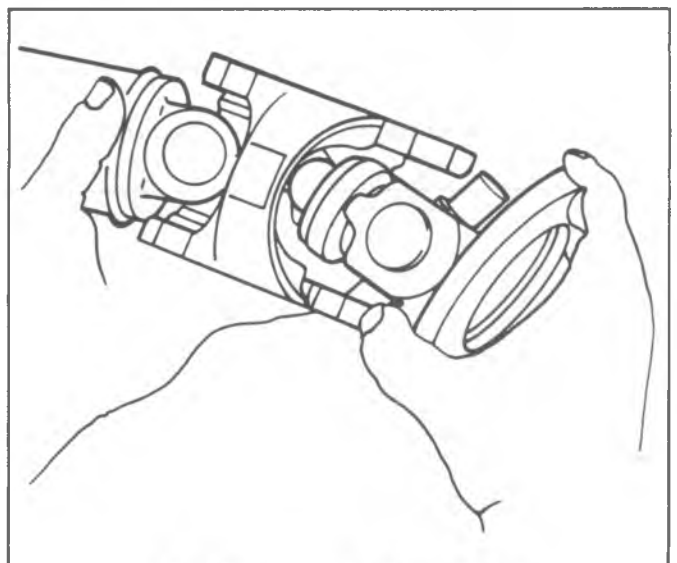

Fig. 31--Reassembling Flange Yoke

29, until the ball can be seen to seat firmly against the shoulder at the base of the stud. This is important as the center of the double Cardan joint is determined by the ball seating tightly in the proper location.

6. Using grease provided in the ball seat kit, lubricate all parts and insert them into the clean ball seat cavity in the following order: spring, washer (smallest OD), three ball seats (with largest opening outward to receive ball), washer (largest OD) and seal.
7. Lubricate seal lip and press seal flush with Tool J-23694, as shown in Fig. 30. Sealing lip should tip inward.
8. Fill cavity with grease provided in kit.
9. Install flange yoke to centering ball as shown in Fig. 31, making sure alignment marks are correctly positioned. Install trunnion and bearing caps as previously outlined.

**LUBRICATION**

The front axle propshaft found on all four-wheel drive trucks requires special lubrication at two locations: The C/V joint, and the slip yoke.

**Constant Velocity Joints (C/V)**

The constant velocity (C/V) joint, located at the transfer case end of the front propshaft, must be lubricated periodically with special lubricant, #1050679, or equivalent. If the fitting cannot be seen from beneath the vehicle Figure 32 shows how the fitting may be lubricated from above the C/V joint, with a special adapter J-25512-2 on the end of a flex hose.

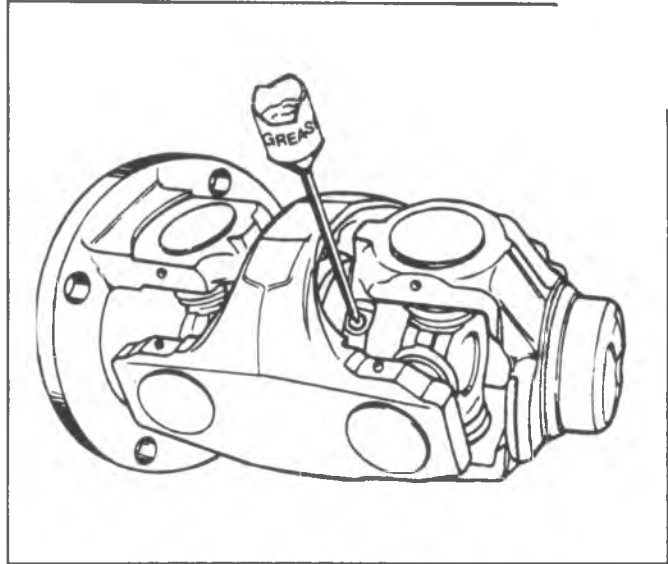

Fig. 32--Lubrication Fitting

**Slip Spline**

Apply chassis lubricant at the fitting until grease begins to leave through the vent hole.

If the slip spline is dry or corroded, it may be necessary to disconnect the propshaft from the truck, remove the slip yoke, and wire brush the affected areas. Wipe clean before reinstallation. When installing the propshaft to transfer case front output flange attaching bolts, torque to specification 95-110 N·m (70-80 ft. lbs.).

| PROPELLER SHAFT  |        |        |       |
|--|--------|--------|-------|
|  | CK     | G      | P     |
| Propeller Shaft  |        |        |       |
| To Rear Axle (Strap)   | 12-17* | 12-17* | 12-17 |
| Bearing Support-to-Hanger  | 23-30  | 20-30  | 20-30 |
| Hanger-to-Frame  | 40-50  | —      | —     |
| To Front Axle (Strap)  | 12-17  |        |       |
| To Transfer Case (Front)   | 70-80  | —      | —     |
| To Transfer Case (Rear)  | 12-17  |        |       |
| Torque Specifications (Ft.-Lbs.)   |        |        |       |
| *Torque Spec. is for Hex Head Bolt, if Straps are Retained with Six Lobe Bolt, Torque to 22 to 30 Ft. Lbs. |        |        |       |

Fig. - SP Specifications

## SECTION 4B

# REAR AXLE

The following notice applies to one or more steps in the assembly procedure of components in this portion of the manual as indicated at appropriate locations by the terminology "See Notice on Page 1 of this Section".

**NOTICE:** This fastener is an important attaching part in that it could affect the performance of vital components and systems, and/or could result in major repair expense. It must be replaced with one of the same part number or with an equivalent part if replacement becomes necessary. Do not use a replacement part of lesser quality or substitute design. Torque values must be used as specified during reassembly to assure proper retention of this part.

### CONTENTS

|   |       |  |        |
|---|-------|--|--------|
| General Description.....                | 4B- 1 | Side Bearing Preload.....                  | 4B-9   |
| Rear Axle Operation.....                | 4B- 2 | Pinion Depth and Backlash.....             | 4B-9   |
| Diagnosis.....                          | 4B- 7 | Chevrolet 8-1/2" and 9-1/2" Ring Gear..... | 4B1-1  |
| Noise Diagnosis.....                    | 4B- 7 | Chevrolet 10-1/2" Ring Gear.....           | 4B2-1  |
| Bearing Diagnosis.....                  | 4B-11 | Dana 10-1/2" Ring Gear.....                | 4B3-1  |
| Maintenance and Lubrication.....        | 4B- 9 | Dana 9-3/4" Ring Gear.....                 | 4B4-1  |
| Axle Identification.....                | 4B-13 | Rockwell 12" Ring Gear.....                | 4B5-1  |
| Operational Checks and Adjustments..... | 4B- 9 | Limited Slip Differential Units.....       | 4B6-1  |
| Gear Tooth Contact Pattern Check.....   | 4B- 9 | Specifications.....                        | 4B10-1 |
| Pinion Bearing Preload.....             | 4B- 9 | Special Tools.....                         | 4B10-1 |

## GENERAL DESCRIPTION

The light duty truck line-up uses six different axles, categorized by ring gear diameter, they are as follows:

### CHEVROLET 8-1/2" AND 9-1/2" RING GEAR AXLE

These axles, shown in figure 4B-1 and 4B-2 are the semifloating, fabricated constructed type consisting of a cast carrier with large bosses on each end into which two welded steel tubes are fitted. The carrier contains an overhung hypoid pinion and ring gear. The differential is a two pinion arrangement.

The axle housing is made up of two steel welded tubes pressed into the crossbore of the cast carrier. Each tube is puddle welded to the carrier. Welded-on brackets provide attachment points for suspension components such as shock absorbers and leaf springs. A welded flange is provided for brake flange plate attachment.

The overhung hypoid drive pinion is supported by two preloaded tapered roller bearings. The pinion shaft is sealed by means of a molded, spring loaded, rubber seal. The hypoid ring gear is bolted to a one-piece differential case which is supported by two preloaded tapered roller bearings.

On the 9 1/2" (Fig. 4B-2) ring gear side bearing preload is controlled by a side bearing adjusting nut threaded into the carrier near the axle tubes. Backlash is adjusted by increasing or decreasing shim thickness.

### CHEVROLET 10-1/2" RING GEAR AXLE

The axle shown in figure 4B-3 is of the full floating type with hypoid ring gear and drive pinion. The full floating construction enables easy removal of axle shafts without removing truck load and without jacking up the axle. The differential carrier is heavily ribbed to provide rigid support for the differential assembly.

The straddle-mounted drive pinion is supported at the front by two opposed tapered roller bearings. The pinion straddle bearing is a roller bearing assembly consisting of an outer race and roller assembly. A precision ground diameter on the pinion pilot functions as an inner race.

Side bearing preload and ring gear-to-pinion backlash are controlled by side bearing adjusting nuts threaded into the carrier near the axle tubes. Pinion depth is controlled by a shim located between the pinion bearing retainer assembly and the differential carrier.

### DANA 10-1/2" RING GEAR AXLE

The Dana axle shown in figure 4B-4 is a Salisbury-type similar in design to the 8-7/8" ring gear axle. It does differ in several points, however. The axle shafts are full floating; the carrier must be spread to remove the differential; and the drive pinion incorporates two shim packs. The inner pack controls pinion depth, while the outer pack controls pinion bearing preload.

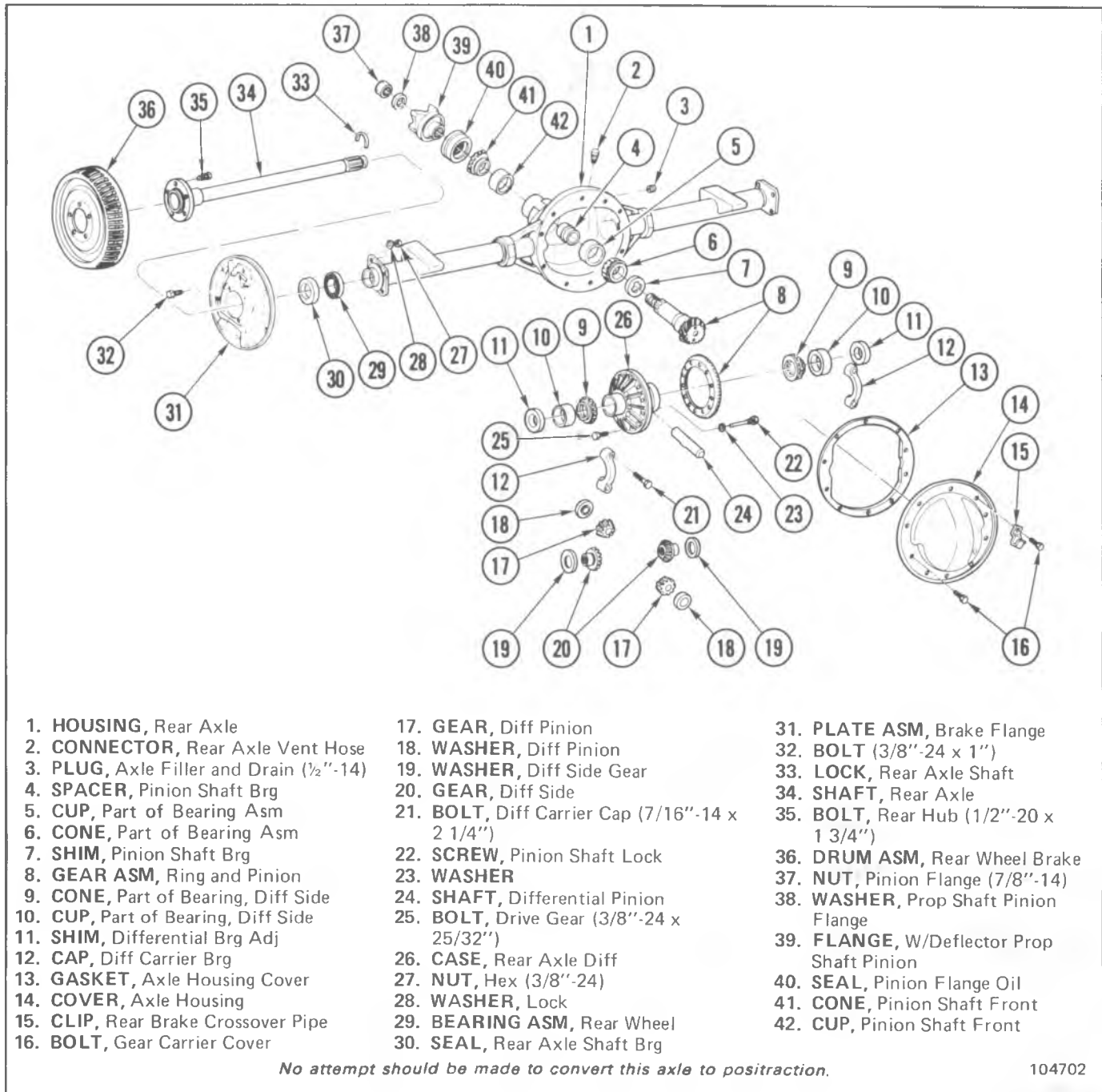

Fig. 4B-1--8-1/2" Ring Gear Axle Typical

**DANA 9-3/4" RING GEAR AXLE**

The Dana axle shown in figure 4B-5 is similar to the unit shown in 4B-4; however, the differential side bearing shims are located between the case and the side bearings.

**ROCKWELL 12" RING GEAR AXLE**

The 11,000 lb. capacity, single-speed hypoid axle, illustrated in figure 4B-5a, has a straddle mounted drive pinion which is supported at the rear by a straight roller bearing. The pinion front bearing consists of a double row ball bearing.

The differential is a conventional four-pinion type. Thrust washers are used between the side gears and case and also between differential pinions and the differential case.

A thrust pad mounted on the end of an adjusting screw threaded into the carrier housing limits deflection of the ring gear under high torque conditions.

Involute splines are incorporated in the axle shaft flange and in the wheel hubs. This design provides for the driving torque to be transmitted from the axle shaft to the hub through the mating splines.

**REAR AXLE OPERATION**

A basic differential consists of a set of four gears. Two of these gears are called differential side gears, and the other two are differential pinion gears. Some differentials have more than two pinion gears. Each side gear is splined to an axle shaft. Consequently, each axle shaft must turn when its side gear rotates.

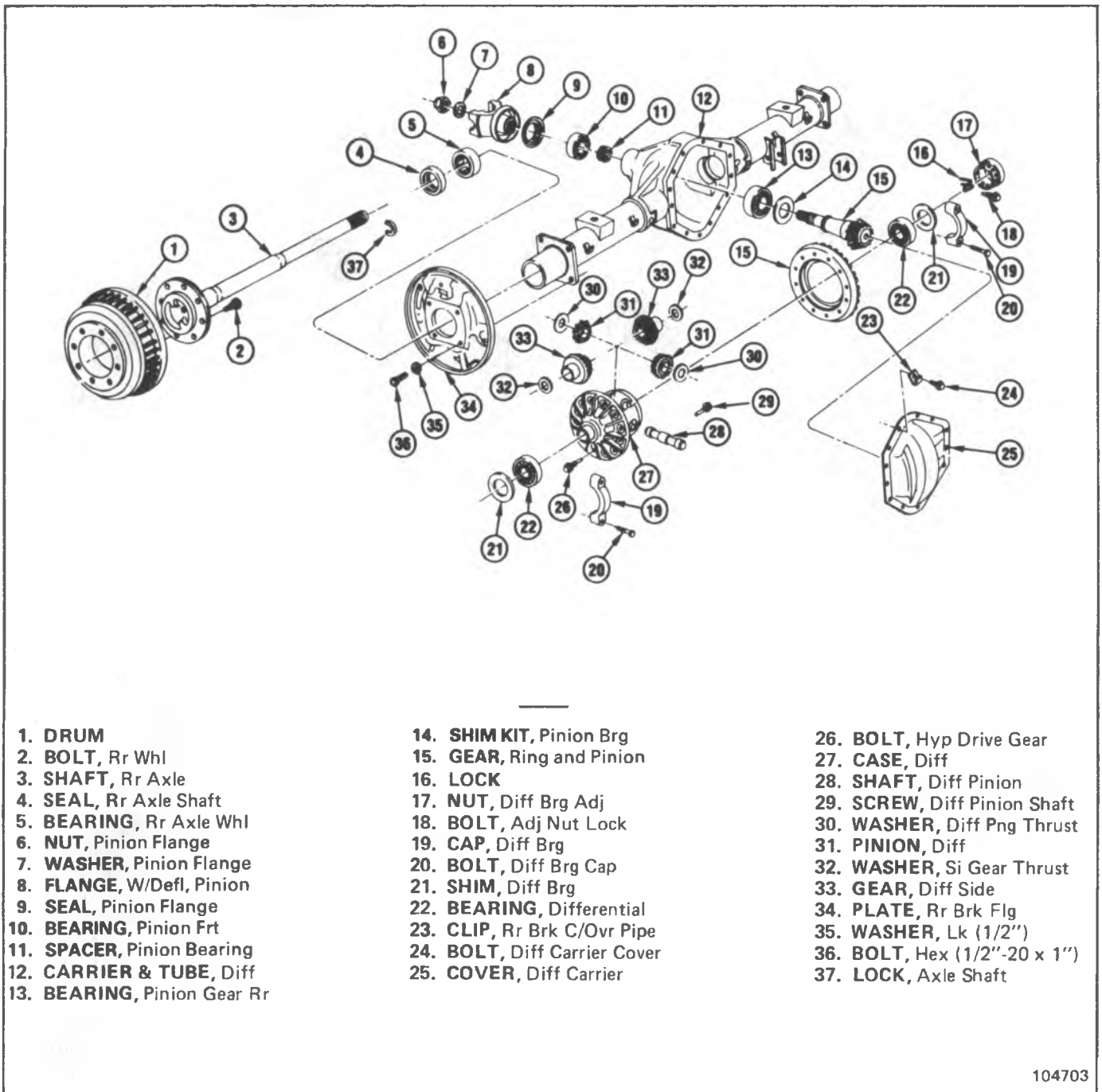

Fig. 4B-2--9 1 1/2" Ring Gear Axle

104703

The differential pinion gears are mounted on a differential pinion shaft, and the gears are free to rotate on this shaft. The pinion shaft is fitted into a bore in the differential case and is at right angles to the axle shafts.

Power flow through the differential is as follows: The drive pinion rotates the ring gear. The ring gear, being bolted to the differential case, rotates the case. The differential pinion, as it rotates with the case, forces the pinion

gears against the side gears. When both wheels have equal traction, the pinion gears do not rotate on the pinion shaft because the input force on the pinion gear is equally divided between the two side gears. Consequently, the pinion gears revolve with the pinion shaft, but do not rotate around the shaft itself. The side gears, being splined to the axle shafts and in mesh with the pinion gears, rotate the axle shafts.

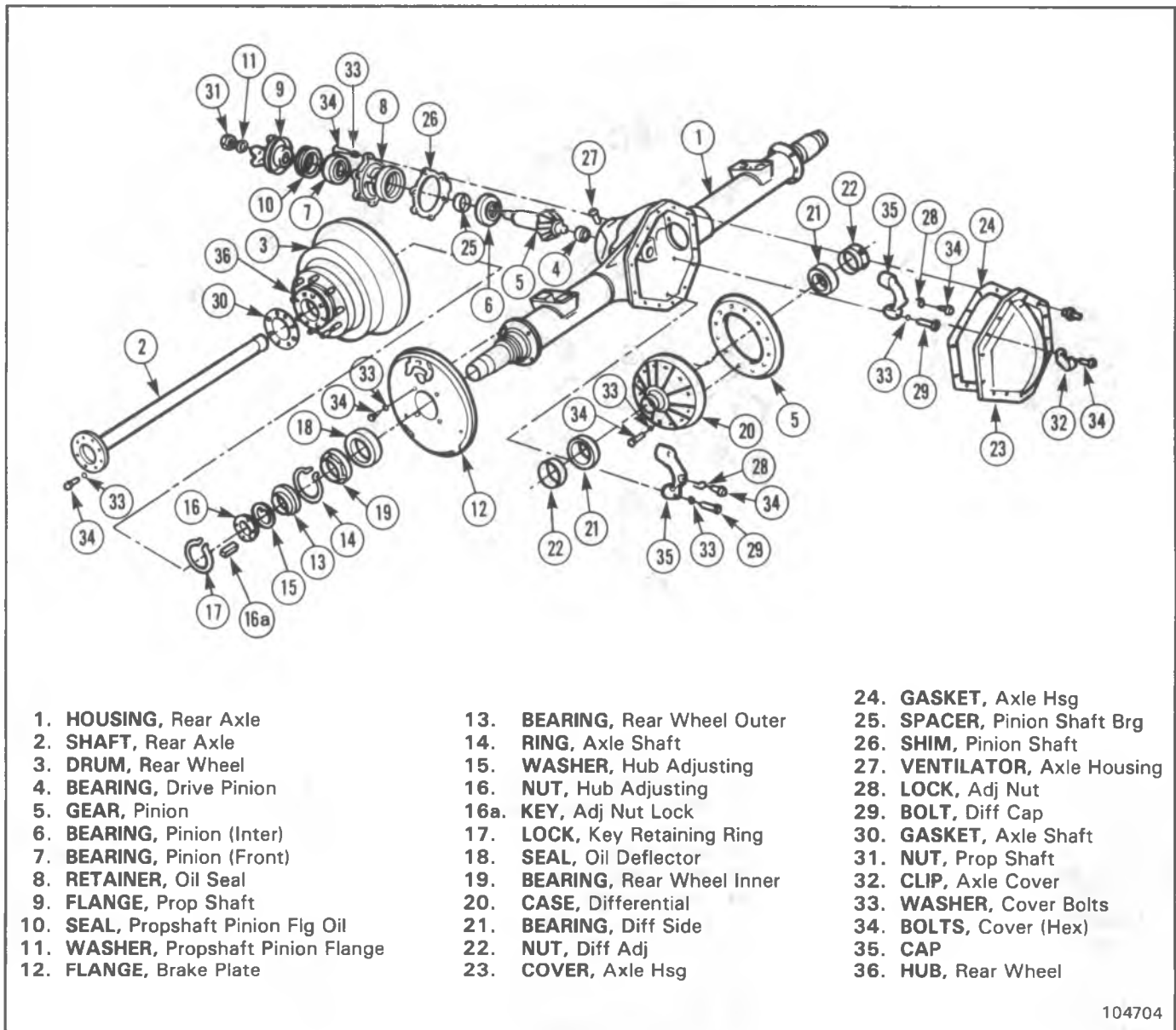

104704

Fig. 4B-3—Chevrolet 10-1/2" Ring Gear Axle Cross-Section

If a vehicle were always driven in a straight line, the ring and pinion gears would be sufficient. The axle shaft could then be solidly attached to the ring gear and both driving wheels would turn at equal speeds.

However, if it became necessary to turn a corner, the tires would scuff and slide because the outer wheel would travel further than the inner wheel. To prevent tire scuffing and sliding, the differential becomes effective and allows the axle shafts to rotate at different speeds.

When the car turns a corner, the outer rear wheel must turn faster than the inner wheel. The inner wheel, turning slower with respect to the outer wheel, slows its rear axle side gear (as the axle shaft is splined to the side gear) and the rear axle pinion gears will roll around the slowed rear axle side gear, driving the other rear axle side gear and wheel faster.

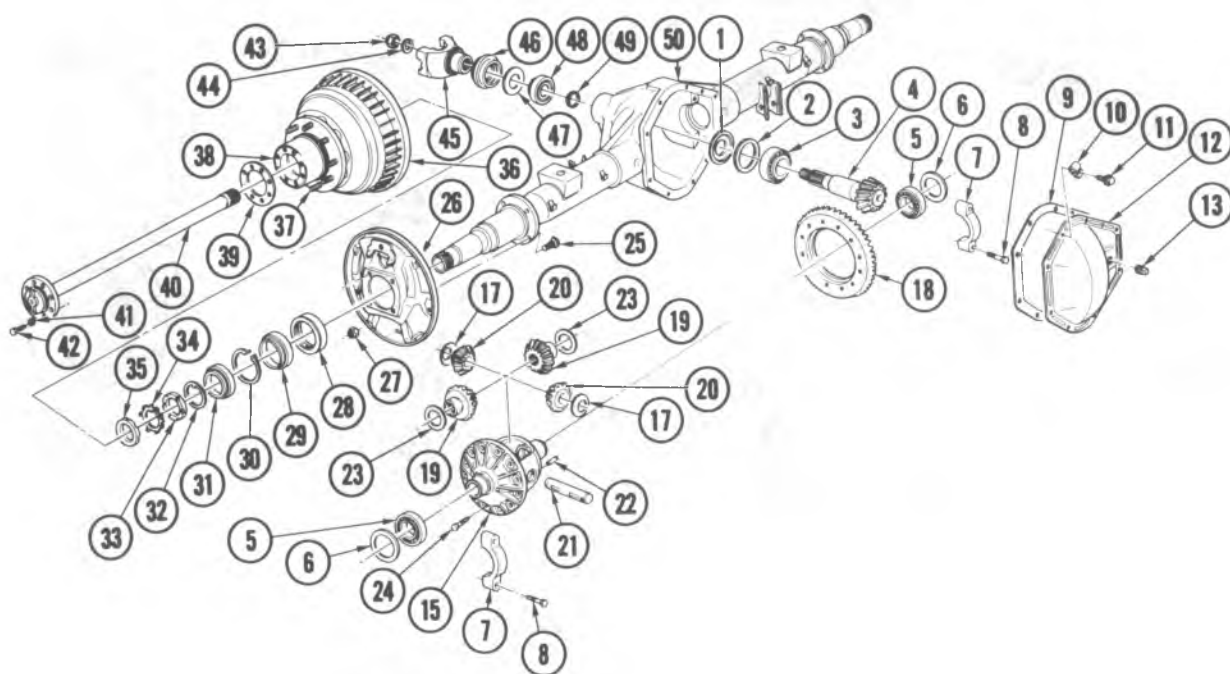

- |  |   |  |
|--|---|--|
| <ul style="list-style-type: none"> <li>1. WASHER, Pinion Brg Spacer</li> <li>2. SHIM, Pinion Shaft Brg Inner</li> <li>3. BEARING ASM, Pinion Rear</li> <li>4. PINION</li> <li>5. BEARING, Diff Side</li> <li>6. SHIM UNIT, Diff Brg Adj</li> <li>7. CAP</li> <li>8. BOLT, Diff Cap</li> <li>9. GASKET, Axle Housing Cover</li> <li>10. CLIP, Axle Cover</li> <li>11. BOLT, Gear Carrier Cover</li> <li>12. COVER, Axle Housing</li> <li>13. PLUG</li> <li>14. BOLT, Diff Case</li> <li>15. CASE, Diff</li> <li>16. PLATE &amp; DISC UNIT, Diff Clu</li> <li>17. WASHER, Diff Pinion</li> </ul> | <ul style="list-style-type: none"> <li>18. RING GEAR</li> <li>19. GEAR, Diff Side</li> <li>20. GEAR, Diff Pinion</li> <li>21. SHAFT, Diff Pinion (Exc P/Trac)<br/>SPIDER, Diff Pinion (W/P/Trac)</li> <li>22. PIN, Pinion Shaft Lock</li> <li>23. WASHER, Diff Side Rear</li> <li>24. BOLT, Ring Gear</li> <li>25. BOLT, Rear Flange Plate</li> <li>26. PLATE ASM, Brg Flange</li> <li>27. NUT (9/16"-18)</li> <li>28. SEAL, Rear Axle Shaft</li> <li>29. BEARING, Rear Wheel Inner</li> <li>30. RING, Rear Axle Shaft Brg</li> <li>31. BEARING, Rear Wheel Outer</li> <li>32. WASHER, Hub Adjusting</li> <li>33. NUT, Hub Adjusting</li> </ul> | <ul style="list-style-type: none"> <li>34. LOCK, Hub Adjusting</li> <li>35. NUT, Hub Adjusting</li> <li>36. DRUM ASM, Rear Wheel</li> <li>37. STUD, Rear Hub</li> <li>38. HUB, Rear Wheel</li> <li>39. GASKET, Rear Axle Shaft</li> <li>40. SHAFT, Rear Axle</li> <li>41. WASHER, Flat</li> <li>42. BOLT, Axle Shaft</li> <li>43. NUT, Pinion Flange</li> <li>44. WASHER, Pinion Flange</li> <li>45. FLANGE, Pinion</li> <li>46. SEAL, Pinion</li> <li>47. SLINGER, Pinion Oil</li> <li>48. BEARING ASM, Pinion Shaft Front</li> <li>49. SHIM, Pinion Shaft Brg Outer</li> <li>50. HOUSING, Rear Axle</li> </ul> |
|--|---|--|

104705

Fig. 4B-4--Dana 10-1/2" Ring Gear Axle Exploded View

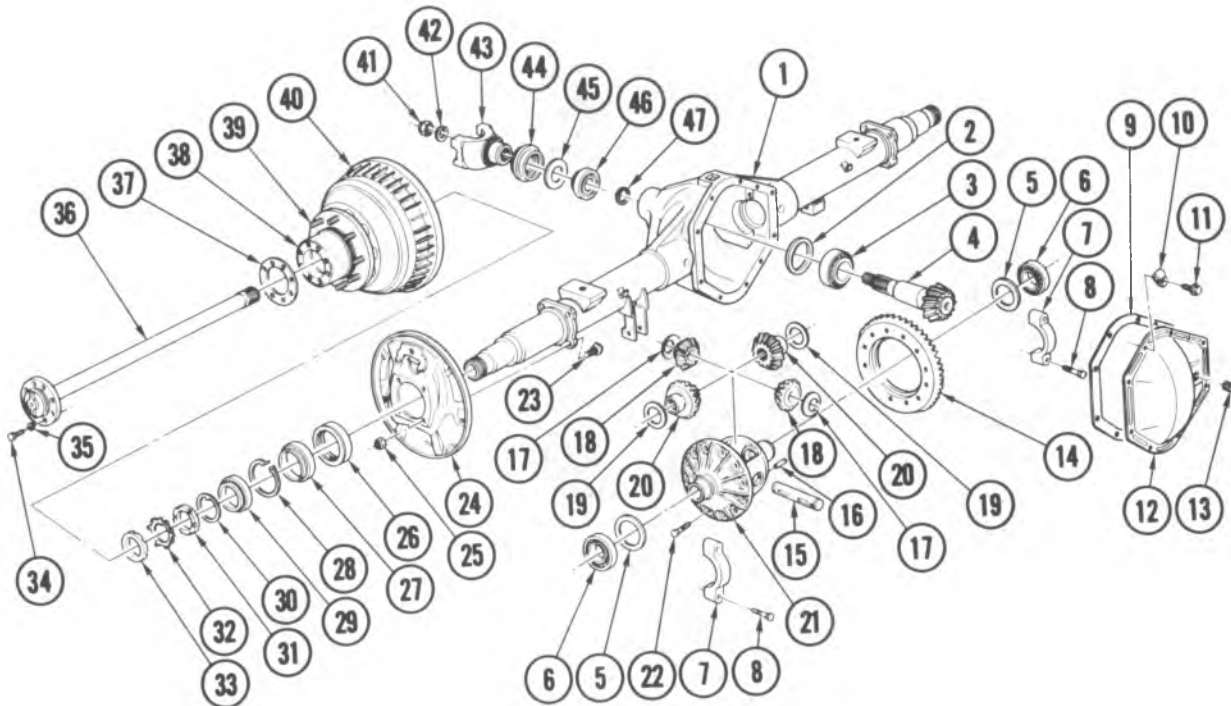

- |                                 |                                   |                                     |
|---------------------------------|-----------------------------------|-------------------------------------|
| 1. HOUSING, Rear Axle           | 17. WASHER, Diff Pinion Thrust    | 33. NUT, Hub Adjusting              |
| 2. SHIM, Pinion Shaft Brg Inner | 18. GEAR, Diff Pinion             | 34. BOLT, Axle Shaft                |
| 3. BEARING ASM, Pinion Rear     | 19. WASHER, Diff Side Gear Thrust | 35. WASHER, Flat                    |
| 4. PINION                       | 20. GEAR, Diff Side               | 36. SHAFT, Rear Axle                |
| 5. SHIM UNIT, Diff Brg Adj      | 21. CASE, Diff                    | 37. GASKET, Rear Axle Shaft         |
| 6. BEARING, Diff Side           | 22. BOLT, Diff Case               | 38. HUB, Rear                       |
| 7. CAP                          | 23. BOLT, Rear Flange Plate       | 39. STUD, Rear Hub                  |
| 8. BOLT, Diff Cap               | 24. PLATE ASM, Brk Flange         | 40. DRUM ASM, Rear Wheel            |
| 9. GASKET, Axle Housing Cover   | 25. NUT (9/16"-18)                | 41. NUT, Pinion Flange              |
| 10. CLIP, Axle Cover            | 26. SEAL, Rear Axle Shaft         | 42. WASHER, Pinion Flange           |
| 11. BOLT, Gear Carrier Cover    | 27. BEARING, Rear Wheel, Inner    | 43. FLANGE, Pinion                  |
| 12. COVER, Axle Housing         | 28. RING, Rear Axle Shaft Brg     | 44. SEAL, Pinion                    |
| 13. PLUG                        | 29. BEARING, Rear Wheel Outer     | 45. SLINGER, Pinion Oil             |
| 14. RING GEAR                   | 30. WASHER, Hub Adjusting         | 46. BEARING ASM, Pinion Shaft Front |
| 15. SHAFT, Diff Pinion          | 31. NUT, Hub Adjusting            | 47. SHIM, Pinion Shaft Brg Outer    |
| 16. PIN, Pinion Shaft Lock      | 32. LOCK, Hub Adjusting           |                                     |

104706

Fig. 4B-5--Dana 9-3/4" Ring Gear Axle Exploded View



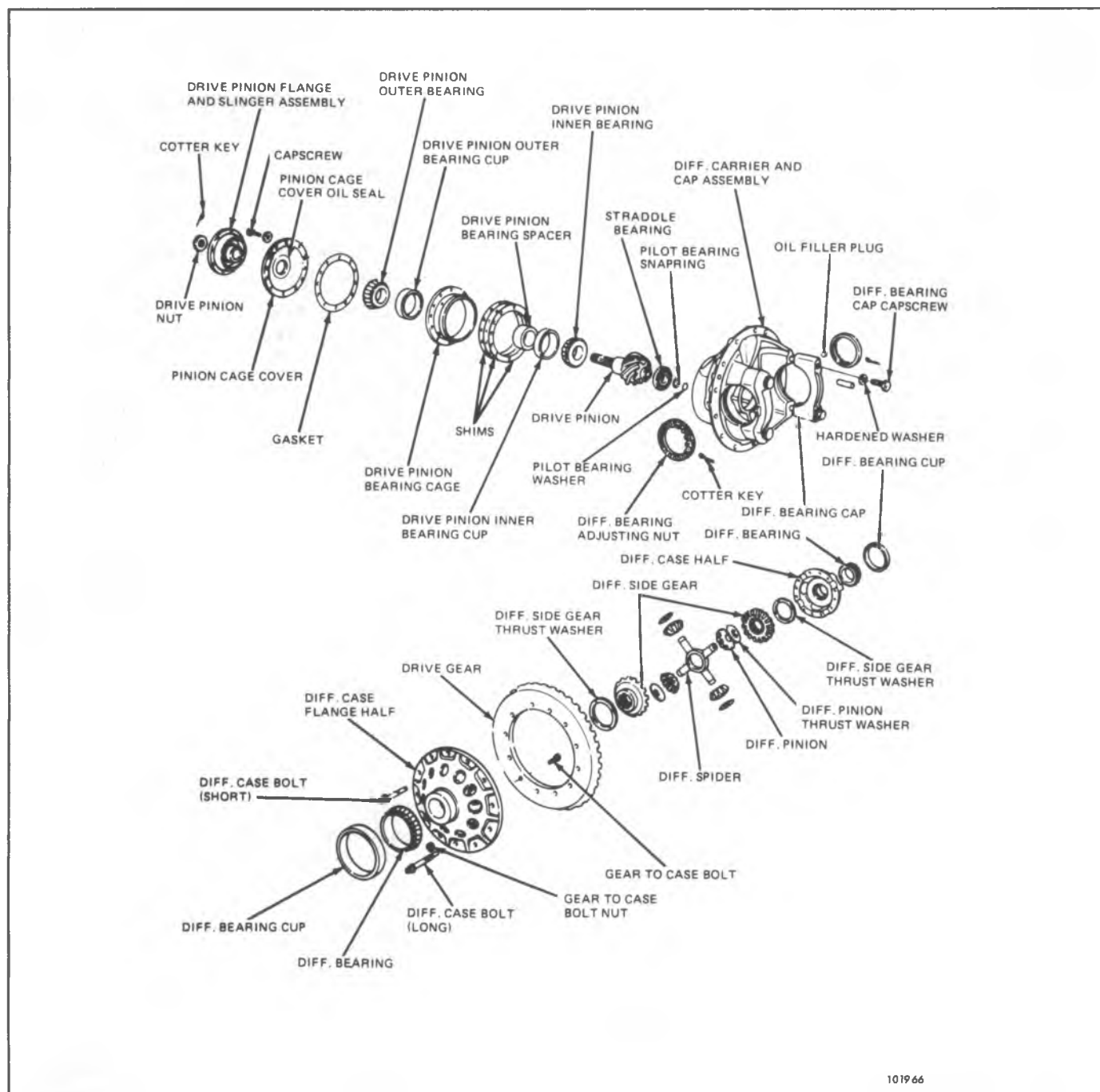

Fig. 4B-5a--Rockwell 12" Ring Gear Axle-11,000# Capacity

## DIAGNOSIS

### NOISE

The most essential part of rear axle service, as with any mechanical repair, is proper diagnosis of the problem, and, in axle work one of the most difficult areas to diagnosis is noise. Locating a broken axle shaft, or broken differential gear, presents little or no problem, but, locating and isolating axle noise can be an entirely different matter.

### Degree of Noise

Any gear driven unit, and especially an automotive drive axle where engine torque multiplication occurs at a

90° turn in the drive line, produces a certain amount of noise. Therefore, an interpretation must be made for each vehicle to determine whether the noise is normal or if a problem actually exists. A normal amount of noise must be expected and cannot be eliminated by conventional repairs or adjustment.

Acceptable noise can be defined as a slight noise heard only at a certain speed or under unusual or remote conditions. For example, this noise tends to reach a "peak" at speeds from 40 to 60 miles per hour (60 to 100 km/h) depending on road and load conditions, or on gear ratio and tire size. This slight noise is in no way

indicative of trouble in the axle assembly.

Drive line noises may baffle even the best diagnostician. Vehicle noises coming from tires, transmission, propeller shaft, universal joints, and front or rear wheel bearings, are often mistaken for axle noise. Such practices as: raising tire pressure to eliminate tire noise (although this will not silence tread noise of mud and snow tires), listening for the noise at varying speeds and road surfaces, on drive, float, and coast conditions will aid in locating the source of alleged axle noises. Thus, every effort should be made to isolate the noise to a specific drive line component instead of making a random guess that could be a costly waste of time.

## Determining Type of Noise

### External Noise

When a rear axle is suspected of being noisy, it is advisable to make a thorough test to determine whether the noise originates in the tires, road surface, front wheel bearings, engine, transmission, or rear axle assembly. Noise which originates in other places cannot be corrected by adjustment or replacement of parts in the rear axle assembly.

**Road Noise**-Some road surfaces, such as brick or rough-surfaced concrete, cause noise which may be mistaken for tire or rear axle noise. Driving on a different type of road, such as smooth asphalt or dirt, will quickly show whether the road surface is the cause of noise. Road noise usually is the same on drive or coast.

**Tire Noise**-Tire noise may easily be mistaken for rear axle noise, even though the noisy tires may be located on the front wheels. Tires worn unevenly, or having surfaces on non-skid divisions worn in saw-tooth fashion, are usually noisy and may produce vibrations which seem to originate elsewhere in the vehicle. This is particularly true with low tire pressure.

**Tire Noise Test**-Tire noise changes with different road surfaces, but rear axle noise does not. Temporarily inflating all tires to approximately 50 pounds pressure, for test purposes only will materially alter noise caused by tires but will not affect noise caused by the rear axle. Rear axle noise usually ceases when coasting at speeds under 30 miles per hour; however, tire noise continues but with lower tone as vehicle speed is reduced. Rear axle noise usually changes when comparing "pull" and "coast" but tire noise remains about the same.

**Engine and Transmission Noises**-Sometimes a noise which seems to originate in the rear axle is actually caused by the engine or transmission. To determine which unit is actually causing the noise, observe approximate car speeds and conditions under which the noise is most pronounced; then stop vehicle in a quiet place to avoid interfering noises. With transmission in neutral, run engine slowly up and down through engine speeds corresponding to vehicle speed at which the noise was most pronounced. If a similar noise is produced with vehicle standing, it is caused by the engine or transmission and not the rear axle.

**Front Wheel Bearing Noise**-Loose or rough front wheel bearings will cause noise which may be confused with rear axle noises; however, front wheel bearing noise does not change when comparing "pull" and "coast". Light application of brake, while holding vehicle speed steady, will often cause wheel bearing noise to diminish, as this takes

some weight off the bearing. Front wheel bearings may be easily checked for noise by jacking up the wheels and spinning them, and also be shaking wheels to determine if bearings are excessively loose.

**Body Boom Noise or Vibration**- Objectional "body boom" noise or vibration at 55-65 mph (90-100 km/h) can be caused by an unbalanced propeller shaft. Excessive looseness at the spline can contribute to this unbalance.

Other items that may also contribute to the noise problem are as follows:

1. Undercoating or mud on the shaft, causing unbalance.
2. Shaft or companion flange balance weights missing.
3. Shaft damage, such as bending, dents, or nicks.
4. Tire-type roughness. Switch tires from a known good car to determine tire fault.

If, after making a comprehensive check of the vehicle, all indications point to the rear axle, further diagnostic steps are necessary to determine the axle components at fault. True axle noises generally fall into two categories: gear noise and bearing noise.

### Rear Axle Noises

If a careful test of vehicle shows that noise is not caused by external items it is then reasonable to assume that noise is caused by rear axle assembly. The rear axle should be tested on a smooth level road to avoid road noise. It is not advisable to test rear axle for noise by running with rear wheels jacked up.

Noises in rear axle assembly may be caused by a faulty propeller shaft, faulty rear wheel bearings, faulty differential or pinion shaft bearings, misalignment between two U-joints, or worn differential side gears and pinions; noises may also be caused by mismatched, improperly adjusted, or scored ring and pinion gear set.

**Rear Wheel Bearing Noise**-A rough rear wheel bearing produces a vibration or growl which continues with vehicle coasting and transmission in neutral. A brinelled rear wheel bearing causes a knock or click approximately every two revolutions of rear wheel, since the bearing rollers do not travel at the same speed as the rear axle and wheel. With rear wheels jacked up, spin rear wheels by hand while listening at hubs for evidence of rough or brinelled wheel bearing.

**Differential Side Gear and Pinion Noise**-Differential side gears and pinions seldom cause noise since their movement is relatively slight on straight ahead driving. Noise produced by these gears will be most pronounced on turns.

**Pinion Bearing** failures can be distinguished because they rotate at higher speeds than differential side bearings and axle shaft bearings. Rough or brinelled pinion bearings produce a continuous low pitched whirring or scraping noise starting at relatively low speed.

**Side Bearings** produce a constant rough noise of a lower pitch than pinion bearings. Side bearing noise may also fluctuate in the above wheel bearing test.

### Gear Noise

There are two basic types of gear noise. The first type is produced by broken, bent, or forcibly damaged gear teeth and is usually quite audible over the entire speed range and presents no particular problem in diagnosis.

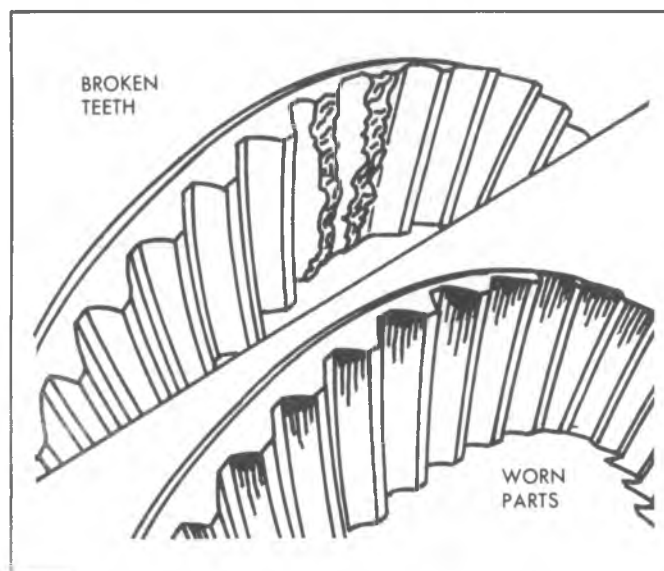

Fig. 4B-6--Two Causes of Gear Noise

For example, hypoid gear tooth scoring generally results from the following: insufficient lubricant improper breakin, improper lubricant, insufficient gear backlash, improper ring and pinion gear alignment, or loss of drive pinion nut torque. The scoring will progressively lead to complete erosion of the gear tooth, or gear tooth pitting and eventual fracture if the initial scoring condition is not corrected. Another cause of hypoid tooth fracture is extended overloading of the gear set which will produce fatigue fracture, or shock loading which will result in sudden failure.

Differential pinion and side gears rarely give trouble. Common causes of differential failure are shock loading, extended overloading, and seizure of the differential pinions to the cross shaft resulting from excessive wheel spin and consequent lubrication breakdown.

The second type of gear noise pertains to the mesh pattern of the gear teeth. This form of abnormal gear noise can be recognized as it produces a cycling pitch (whine) and will be very pronounced in the speed range at which it occurs, appearing under either "drive", "float" or "coast" conditions. "Drive" is acceleration or heavy pull. "Coast" is with a closed throttle and vehicle in gear and "float" is using just enough throttle to keep the car from driving the engine-the vehicle slows down gradually but engine still pulls slightly. Gear noise tends to peak in a narrow speed range or ranges, and will tend to remain constant in pitch. Bearing noise will vary in pitch with vehicle speeds. See figure 4B-7.

## MAINTENANCE AND LUBRICATION

Refer to Section 0B for periodic maintenance and lubrication requirements.

## OPERATIONAL CHECK AND ADJUSTMENTS

Four adjustments are essential for proper operation of the differential and its related parts. These adjustments are a) Pinion Bearing Preload, b) Side Bearing Preload, c) Pinion Depth and d) Ring Gear-to-Pinion Backlash.

Pinion Bearing Preload is set to specifications in step 9 of 'Drive Pinion Reassembly'.

Side Bearing Preload is set to specifications in step 6 of 'Differential Case-Installation and Adjustment'.

Following service to the Differential assembly or to the Drive Pinion, the Pinion Depth and Ring-Gear-to-Pinion Backlash **must** be checked, using a Gear Tooth Contact Pattern Check as outlined below.

## Gear Tooth Contact Pattern Check

Prior to final assembly of the differential, a Gear Tooth Contact Pattern Check is necessary to verify the correct relationship between ring gear and drive pinion. Gear sets which are not positioned properly may be noisy, or have short life, or both. With a pattern check, the most desirable contact between ring gear and drive pinion for low noise level and long life can be assured.

## Gear Tooth Nomenclature

The side of the ring gear tooth which curves outward, or is convex, is referred to as the 'drive' side. The concave side is the 'coast' side. The end of the tooth nearest center of ring gear is referred to as the 'toe-in' end. The end of the tooth farthest away from center is the 'heel' end. Toe end of tooth is smaller than heel end. See figure 4B-8.

## Pattern Check

1. Wipe oil out of carrier and carefully clean each tooth of ring gear.
2. Use gear marking compound and apply this mixture to ring gear teeth. When properly applied, the area of tooth contact will be clearly visible after load is applied.
3. Tighten bearing cap bolts to specifications.
4. Apply load to gears by expanding brake shoes or by wrapping a heavy rag around the companion flange to resist rotation.

**NOTICE:** A test made without loading the gears will not give a satisfactory pattern. Turn companion flange with wrench so that ring gear rotates one full revolution then reverse rotation so that ring gear rotates one revolution in opposite direction. Excessive turning of ring gear is not recommended.

5. Observe pattern on ring gear teeth and compare with figure 4B-9. Make adjustments as outlined below.
6. The important thing to achieve in the pattern check and subsequent adjustments is to locate the contact pattern centrally on the face of the ring gear teeth.

## Pinion Depth Adjustment

1. The pinion depth shim may be replaced as necessary to place the drive pinion at the correct depth. See figure 4B-9.
2. Depth shims are available from .006 inch to .024 inch, in increments of .001 inch.

## Backlash Adjustment

1. Remove locking retainers from side bearing adjusting nuts.
2. Move adjusting nuts **an equal amount** in or out to achieve proper backlash.
  - a. To increase backlash, loosen the left adjusting nut and tighten the right adjusting nut **an equal amount**.
  - b. To decrease backlash, loosen the right adjusting nut and tighten the left adjusting nut **an equal amount**.

| Problem   | Cause   |
|---|---|
| 1. Noise is the same in drive or coast  | 1. a) Road noise<br>b) Tire noise<br>c) Front wheel bearing noise   |
| 2. Noise changes on a different type of road  | 2. a) Road noise<br>b) Tire noise   |
| 3. Noise tone lowers as vehicle speed is lowered                                      | 3. Tire noise   |
| 4. Similar noise is produced with vehicle standing and driving                        | 4. a) Engine noise<br>b) Transmission noise   |
| 5. Vibration  | 5. a) Rough rear wheel bearing<br>b) Unbalanced or damaged propeller shaft<br>c) Tire unbalance<br>d) Worn universal joint in propeller shaft<br>e) Mis-indexed propeller shaft at companion flange<br>f) Companion flange runout too great |
| 6. A knock or click approximately every two revolutions of rear wheel                 | 6. A brinelled rear wheel bearing   |
| 7. Noise most pronounced on turns   | 7. Differential side gear and pinion  |
| 8. A continuous low pitch whirring or scraping noise starting at relatively low speed | 8. Pinion bearing   |
| 9. Drive noise, coast noise or float noise  | 9. Ring and pinion gear   |
| 10. Clunk on acceleration or deceleration   | 10. Worn differential cross shaft in case   |
| 11. Grunt on stops  | 11. No grease in propeller shaft slip yoke  |
| 12. Groan in Forward or Reverse   | 12. Wrong lube in differential  |
| 13. Chatter on turns<br>(locking differential)  | 13. a) Lubricant contaminated<br>b) Clutch plates worn  |
| 14. Clunk or knock on rough road operation  | 14. Excessive end play of axle shafts to differential cross shaft   |

Fig. 4B-7--Diagnosis of Noise Problems

## DIFFERENTIAL AND REAR AXLE BEARING DIAGNOSIS

CONSIDER THE FOLLOWING FACTORS WHEN DIAGNOSING BEARING CONDITION:

1. GENERAL CONDITION OF ALL PARTS DURING DISASSEMBLY AND INSPECTION.
2. CLASSIFY THE FAILURE WITH THE AID OF THE ILLUSTRATIONS.
3. DETERMINE THE CAUSE.
4. MAKE ALL REPAIRS FOLLOWING RECOMMENDED PROCEDURES.

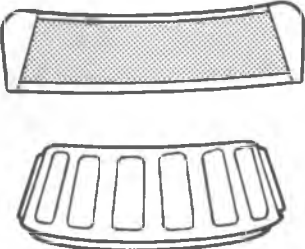
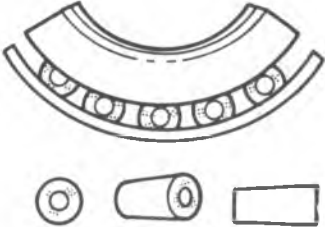
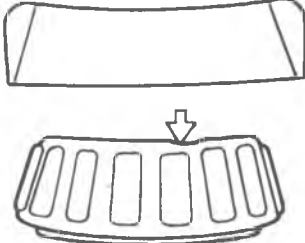
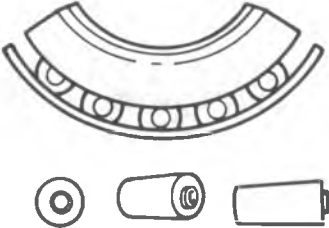
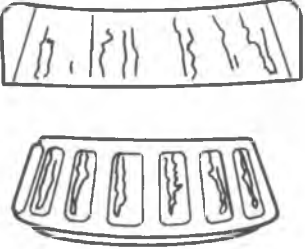
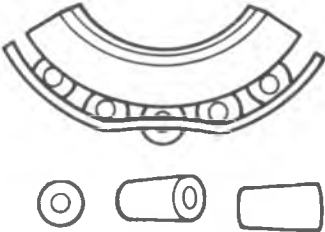
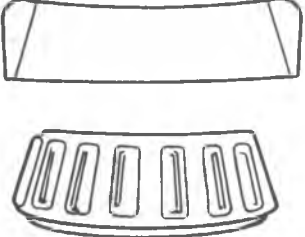
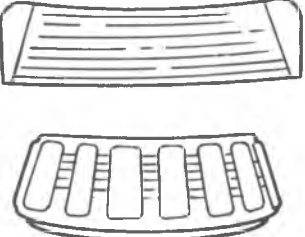
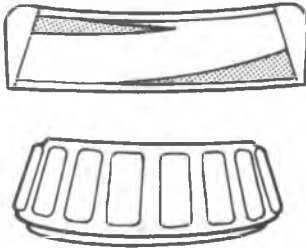
|   |  |  |
|---|--|--|
|  <p><b>ABRASIVE ROLLER WEAR</b></p> <p>PATTERN ON RACES AND ROLLERS CAUSED BY FINE ABRASIVES</p> <p>CLEAN ALL PARTS AND HOUSINGS. CHECK SEALS AND BEARINGS AND REPLACE IF LEAKING, ROUGH OR NOISY.</p>           |  <p><b>GALLING</b></p> <p>METAL SMears ON ROLLER ENDS DUE TO OVERHEAT, LUBRICANT FAILURE OR OVERLOAD</p> <p>REPLACE BEARING CHECK SEALS AND CHECK FOR PROPER LUBRICATION</p>   |  <p><b>BENT CAGE</b></p> <p>CAGE DAMAGE DUE TO IMPROPER HANDLING OR TOOL USAGE</p> <p>REPLACE BEARING</p>   |
|  <p><b>ABRASIVE STEP WEAR</b></p> <p>PATTERN ON ROLLER ENDS CAUSED BY FINE ABRASIVES</p> <p>CLEAN ALL PARTS AND HOUSINGS. CHECK SEALS AND BEARINGS AND REPLACE IF LEAKING, ROUGH OR NOISY</p>                   |  <p><b>ETCHING</b></p> <p>BEARING SURFACES APPEAR GRAY OR GRAYISH BLACK IN COLOR WITH RELATED ETCHING AWAY OF MATERIAL USUALLY AT ROLLER SPACING</p> <p>REPLACE BEARINGS CHECK SEALS AND CHECK FOR PROPER LUBRICATION</p> |  <p><b>BENT CAGE</b></p> <p>CAGE DAMAGE DUE TO IMPROPER HANDLING OR TOOL USAGE</p> <p>REPLACE BEARING</p>  |
|  <p><b>INDENTATIONS</b></p> <p>SURFACE DEPRESSIONS ON RACE AND ROLLERS CAUSED BY HARD PARTICLES OF FOREIGN MATERIAL</p> <p>CLEAN ALL PARTS AND HOUSINGS CHECK SEALS AND REPLACE BEARINGS IF ROUGH OR NOISY</p> |  <p><b>CAGE WEAR</b></p> <p>WEAR AROUND OUTSIDE DIAMETER OF CAGE AND ROLLER POCKETS CAUSED BY ABRASIVE MATERIAL AND INEFFICIENT LUBRICATION</p> <p>CLEAN RELATED PARTS AND HOUSINGS CHECK SEALS AND REPLACE BEARINGS</p> |  <p><b>MISALIGNMENT</b></p> <p>OUTER RACE MISALIGNMENT DUE TO FOREIGN OBJECT</p> <p>CLEAN RELATED PARTS AND REPLACE BEARING MAKE SURE RACES ARE PROPERLY SEATED</p> |

## DIFFERENTIAL AND REAR AXLE BEARING DIAGNOSIS (CONT'D)

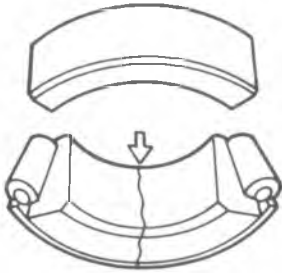

### CRACKED INNER RACE

RACE CRACKED DUE TO IMPROPER FIT, COCKING, OR POOR BEARING SEATS

REPLACE BEARING AND CORRECT BEARING SEATS

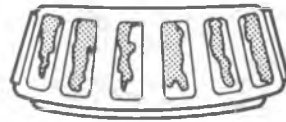

### FATIGUE SPALLING

FLAKING OF SURFACE METAL RESULTING FROM FATIGUE

REPLACE BEARING - CLEAN ALL RELATED PARTS

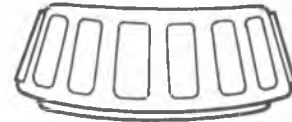

### BRINELLING

SURFACE INDENTATIONS IN RACEWAY CAUSED BY ROLLERS EITHER UNDER IMPACT LOADING OR VIBRATION WHILE THE BEARING IS NOT ROTATING

REPLACE BEARING IF ROUGH OR NOISY



### FRETAGE

CORROSION SET UP BY SMALL RELATIVE MOVEMENT OF PARTS WITH NO LUBRICATION.

REPLACE BEARING. CLEAN RELATED PARTS. CHECK SEALS AND CHECK FOR PROPER LUBRICATION

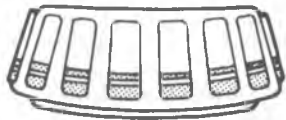

### STAIN DISCOLORATION

DISCOLORATION CAN RANGE FROM LIGHT BROWN TO BLACK CAUSED BY INCORRECT LUBRICANT OR MOISTURE

RE USE BEARINGS IF STAINS CAN BE REMOVED BY LIGHT POLISHING OR IF NO EVIDENCE OF OVER HEATING IS OBSERVED.

CHECK SEALS AND RELATED PARTS FOR DAMAGE.

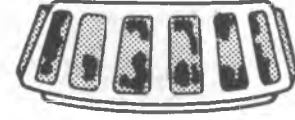

### HEAT DISCOLORATION

HEAT DISCOLORATION CAN RANGE FROM FAINT YELLOW TO DARK BLUE RESULTING FROM OVER LOAD (WAGON'S) OR INCORRECT LUBRICANT

EXCESSIVE HEAT CAN CAUSE SOFTENING OF RACES OR ROLLERS.

TO CHECK FOR LOSS OF TEMPER ON RACES OR ROLLERS A SIMPLE FILE TEST MAY BE MADE. A FILE DRAWN OVER A TEMPERED PART WILL GRAB AND CUT METAL, WHEREAS, A FILE DRAWN OVER A HARD PART WILL GLIDE READILY WITH NO METAL CUTTING

REPLACE BEARINGS IF OVER HEATING DAMAGE IS INDICATED. CHECK SEALS AND OTHER PARTS



### SMEARS

SMEARING OF METAL DUE TO SLIPPAGE. SLIPPAGE CAN BE CAUSED BY POOR FITS, LUBRICATION, OVERHEATING, OVERLOADS OR HANDLING DAMAGE

REPLACE BEARINGS. CLEAN RELATED PARTS AND CHECK FOR PROPER FITS AND LUBRICATION

LIGHT DUTY TRUCK REAR AXLE IDENTIFICATION

Chevrolet Light Duty Trucks use either Chevrolet or Dana produced rear axle assemblies. See examples of production codes below.

CHEVROLET AXLE



Code is staped on top of right axle tube outboard of carrier.

DANA AXLE



Code is stamped on rear surface of right axle tube.

The Chevrolet produced axles use a prefix code stamped into the axle tube for axle ratio identification. Dana produced axles use the same prefix code as the Chevrolet axles but they display these codes on a strip of tape attached to the outboard end of the axle tube.

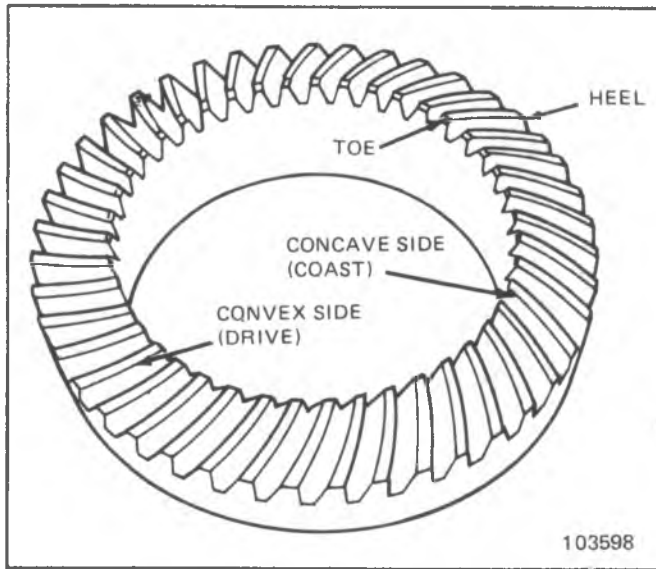

Fig. 4B-8—Gear Tooth Nomenclature

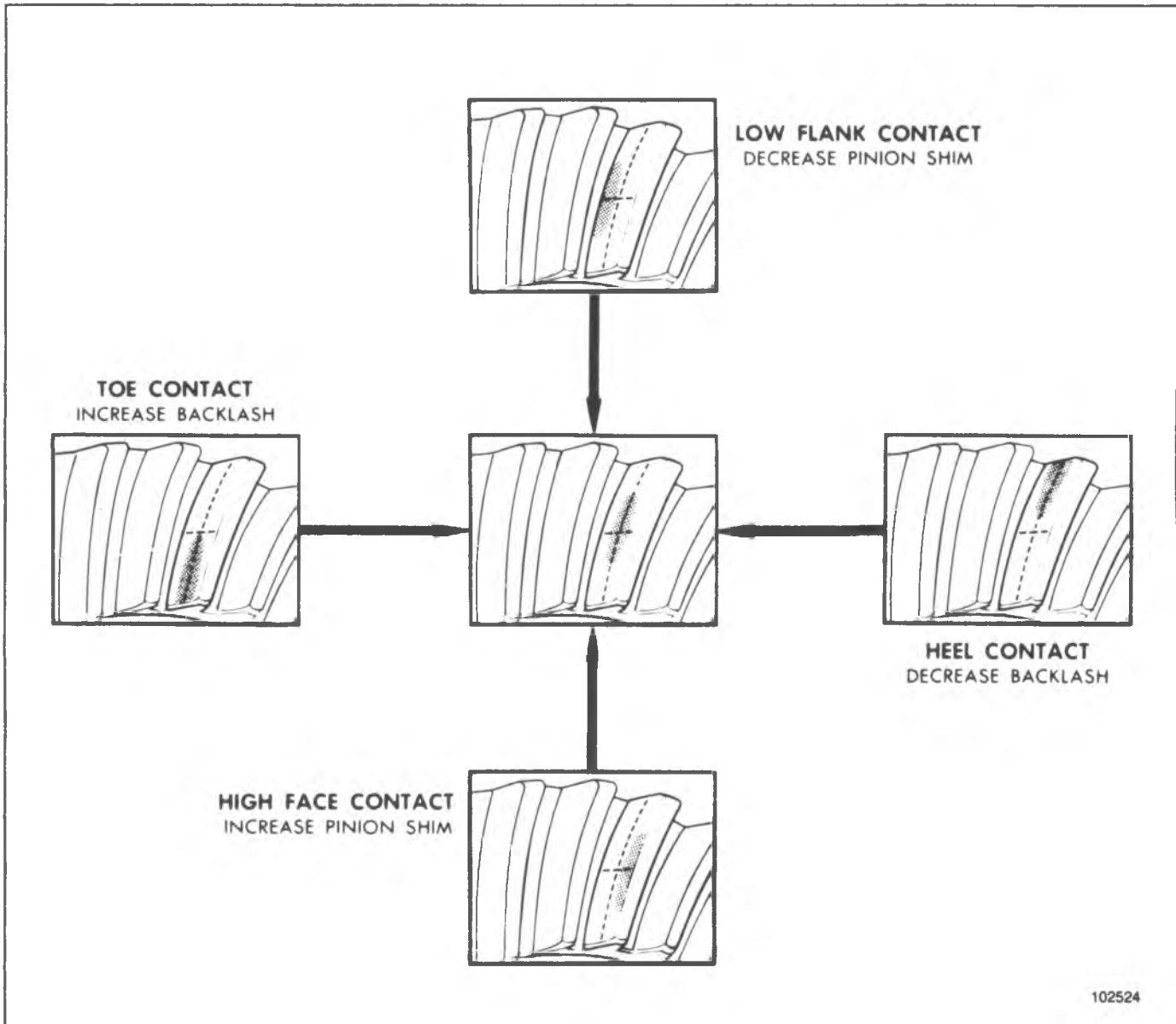

Fig. 4B-9—Gear Tooth Contact Pattern Check



## SECTION 4B1

**8-1/2" and 9-1/2" RING GEAR AXLE**

The following notice applies to one or more steps in the assembly procedure of components in this portion of the manual as indicated at appropriate locations by the terminology "See Notice on Page 1 of this Section".

**NOTICE:** This fastener is an important attaching part in that it could affect the performance of vital components and systems, and/or could result in major repair expense. It must be replaced with one of the same part number or with an equivalent part if replacement

becomes necessary. Do not use a replacement part of lesser quality or substitute design. Torque values must be used as specified during reassembly to assure proper retention of this part.

**CONTENTS**

|                                     |       |  |        |
|-------------------------------------|-------|--|--------|
| On-Vehicle Service .....            | 4B1-1 | Bearing Replacement .....                        | 4B1-6  |
| Axle Assembly .....                 | 4B1-1 | Ring Gear or Differential Case Replacement ..... | 4B1-7  |
| Axle Shaft .....                    | 4B1-1 | Backlash Adjustment.....                         | 4B1-8  |
| Oil Seal/Bearing .....              | 4B1-3 | Drive Pinion .....                               | 4B1-10 |
| Brake Backing Plate.....            | 4B1-4 | Drive Pinion Bearing .....                       | 4B1-11 |
| Wheel Bolts.....                    | 4B1-4 | Setting Pinion Depth .....                       | 4B1-12 |
| Pinion Flange (Dust Deflector)..... | 4B1-4 | Installation and Adjustment.....                 | 4B1-13 |
| Unit Repair .....                   | 4B1-6 | Operational Checks and Adjustments .....         | 4B1-15 |
| Differential Case.....              | 4B1-6 |  |        |

**ON-VEHICLE SERVICE**

Construction of the axle assembly is such that service operations may be performed with the housing installed in the vehicle or with the housing installed in a holding fixture. The following removal and installation procedure is necessary only when the housing requires replacement.

**NOTICE:** See NOTICE on page 1 of this section, regarding Axle Assembly fasteners.

**Removal**

1. Raise vehicle on hoist.
2. Support rear axle assembly with suitable lifting device, so that tension is relieved in springs and shock absorbers.
3. Remove trunnion bearing "U" bolts from the axle companion flange, separate trunnion from flange, position propeller shaft to one side and tie it to frame side rail.  
Secure trunnion bearing caps to trunnion, using masking tape or a large rubber band, to prevent loss of bearings.
4. Disconnect shock absorbers at lower attachment points and position out of the way.
5. Disconnect axle vent hose from vent connector and position vent hose to one side.
6. Disconnect hydraulic brake hose at connector on axle housing. Remove brake drum, disconnect parking brake cable at actuating levers and at flange plate. Refer to Section 5 for cable removal and brake details. Remove axle "U" bolt nuts, "U" bolts, spacers and clamp plates.

7. Lower axle assembly and remove from vehicle.

**Installation**

1. Position axle assembly under vehicle and align with springs.
2. Install spacer, clamp plate and "U" bolts to axle assembly, loosely install retaining nuts to "U" bolts.
3. Position shock absorbers in lower attachment brackets and loosely install nut to retain shock.
4. Connect axle vent hose to vent connector at carrier.
5. Connect hydraulic brake hose to connector on axle housing, connect parking brake cable to actuating levers. Install brake drum and wheel and tire assembly-bleed brakes and adjust parking brake as outlined in applicable portion of Brake Section.
6. Reassemble the propeller shaft to companion flange, making sure that bearing caps are indexed in flange seat. Torque bearing cap retaining nuts to specifications.
7. Position vehicle so that weight is placed on suspension components and torque affected parts to specifications.
8. Lower vehicle and remove from hoist.

**AXLE SHAFT****Removal**

1. Raise vehicle on hoist. Remove wheel and tire assembly and brake drums.
2. Clean all dirt from around carrier cover.
3. Drain lubricant from carrier by removing cover.

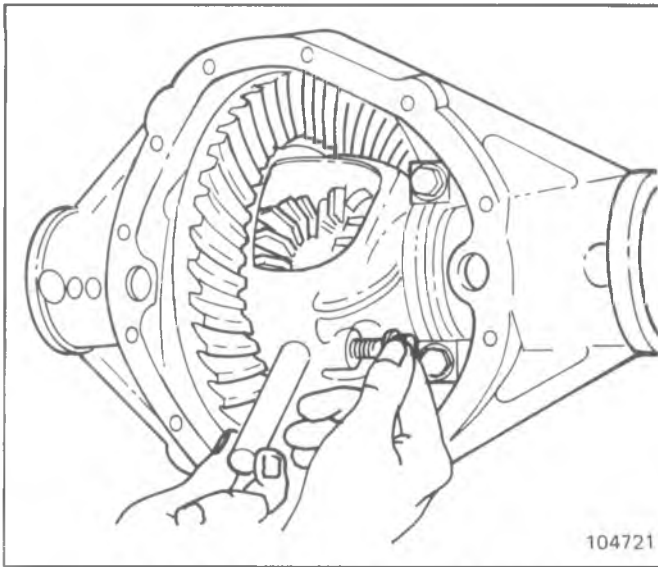

Fig. 4B1-1--Differential Pinion Shaft Removal

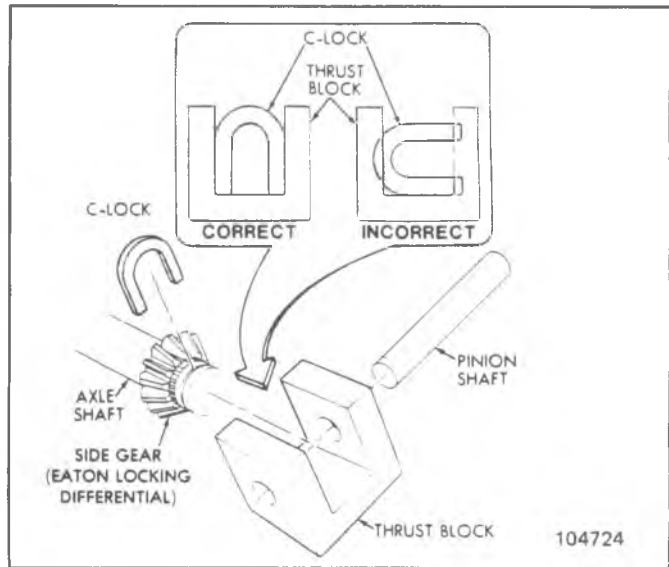

Fig. 4B1-4--Correct C-Lock Position

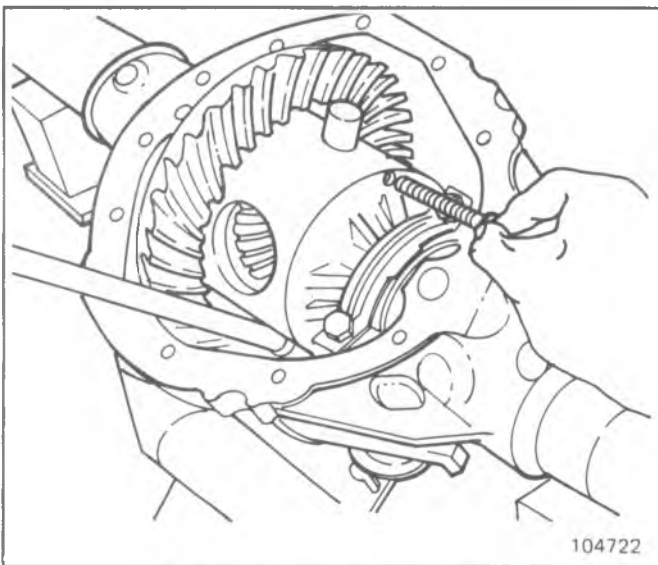

Fig. 4B1-2--Removing Lock Screw

4. Remove the differential pinion shaft lock screw and the differential pinion shaft as shown in figure 4B1-1.
5. Push flanged end of axle shaft toward center of vehicle and remove "C" lock from button end of shaft.
6. Remove axle shaft from housing, being careful not to damage oil seal.

When removing the axle shaft on the 9 1/2" ring gear axle, be sure the thrust washer in the differential case does not slid out.

Axles equipped with Eaton Locking differentials use a thrust block on the pinion shaft which affects the removal of axle shafts as noted below.

1. Raise the vehicle on a hoist. Remove both rear wheel and tire assemblies and both rear brake drums.
2. Remove the rear cover and drain the lubricant.
3. Rotate the case to the position shown in figure 4B1-2. Support the pinion shaft so that it cannot fall into the case, then remove the lock screw.

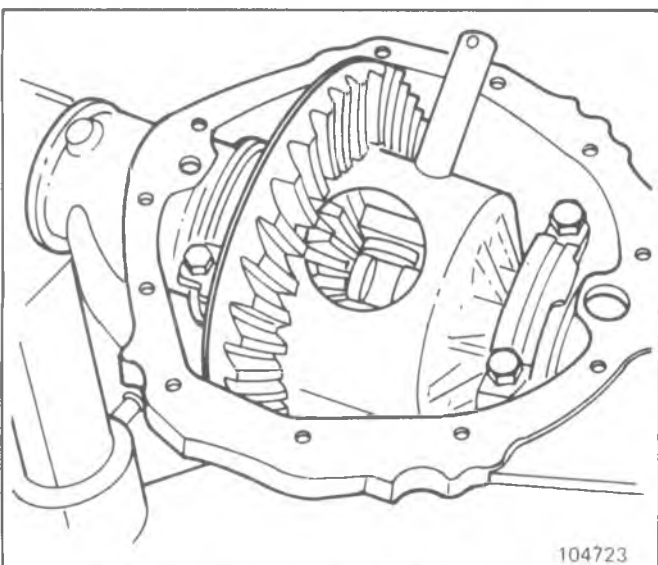

Fig. 4B1-3--Positioning Case For Best Clearance

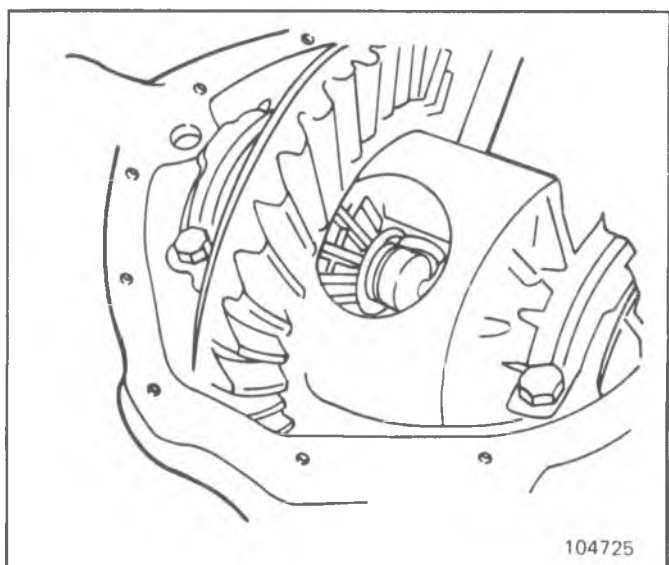

Fig. 4B1-5--Push Axle Shaft Inward

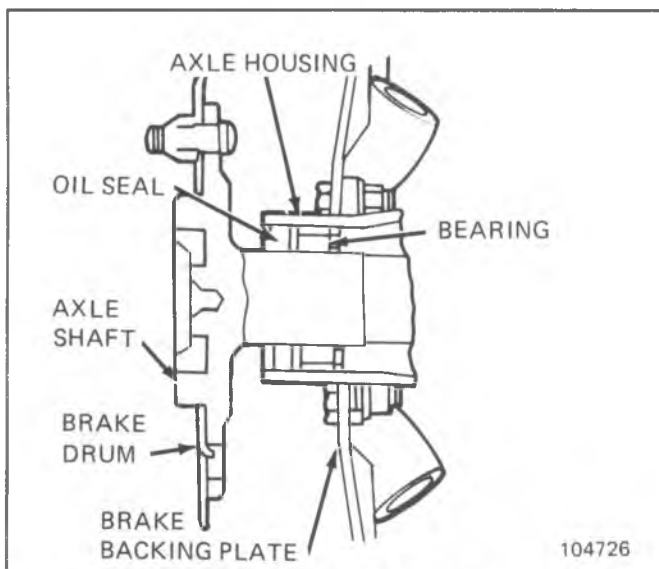

Fig. 4B1-6--Oil Seal and Wheel Bearing

4. Carefully withdraw the pinion shaft part-way out, as shown in figure 4B1-3. Rotate the case until the shaft touches the housing.
5. Reach into the case with a screwdriver or similar tool, and rotate the C-lock until its open end points directly inward, as shown in figure 4B1-4. The axle shaft cannot be pushed inward until the C-lock is properly positioned.  
**Do not force or hammer the axle shaft** in an attempt to gain clearance.
6. When the C-lock is positioned to pass through the end of the thrust block, push the axle shaft inward as shown in figure 4B1-5, and remove the C-lock. Remove the axle shaft and repeat steps 5 and 6 for the opposite axle shaft.

**Oil Seal/Bearing-Replacement Fig. 4B1-6**

1. Remove oil seal by using button end of axle shaft. Insert button end behind the steel case of the oil seal, then pry seal out of bore. If both seal and bearing are being replaced proceed to step 2.

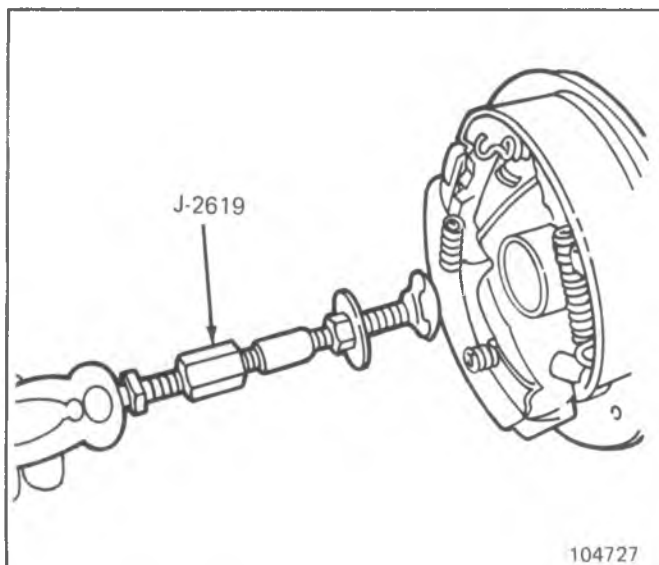

Fig. 4B1-7--Wheel Bearing Removal

2. Using J-23689, insert into bore so that tool grasps bearing behind the bearing. See figure 4B1-7. Slide washer behind outside of seal (or bearing) and turn nut finger tight against washer. Attach Slide Hammer J-2619 and remove bearing and seal.

On 9 1/2 inch ring gear axles, use tool J-29712. Insert (wobble plate) into axle tube so that it grasps behind the bearing. Center receiver on axle tube and tighten nut.

3. Back off nut and remove bearing and seal from tool.
4. Lubricate cavity between seal lips with wheel bearing lubricant and also lubricate new bearing with wheel bearing lubricant.
5. To reinstall bearing, use J-23690 Installer, or J-29709 for the 9 1/2 inch ring gear. Install bearing until tool bottoms against tube as illustrated in figure 4B1-8.
6. To install oil seal, place seal on J-21128 or J-29713 for the 9 1/2 inch ring gear and drive into bore until tool bottoms against end of tube. Refer to figure 4B1-9. This tool installs the seal flush with the end of the tube.

**Axle Shaft-Installation**

1. Slide axle shaft into place. Exercise care that splines on end of shaft do not damage oil seal and that they engage with splines of differential side gear.
2. Install axle shaft "C" locks as follows:
  - a. With standard differential, install axle shaft "C" lock on button end of axle shaft and push shaft outward so that shaft lock seats in counterbore of differential side gear. Then, position differential pinion shaft through case and pinions, aligning hole in shaft with lock screw hole. Install lock screw.
  - b. With locking differential, install "C" locks keeping the pinion shaft partially withdrawn. Place the "C" locks in the same position shown in Fig. 4B1-4. Carefully withdraw the axle shaft until the "C" lock is clear of the thrust block. When both locks are installed, install the pinion shaft aligning hole in shaft

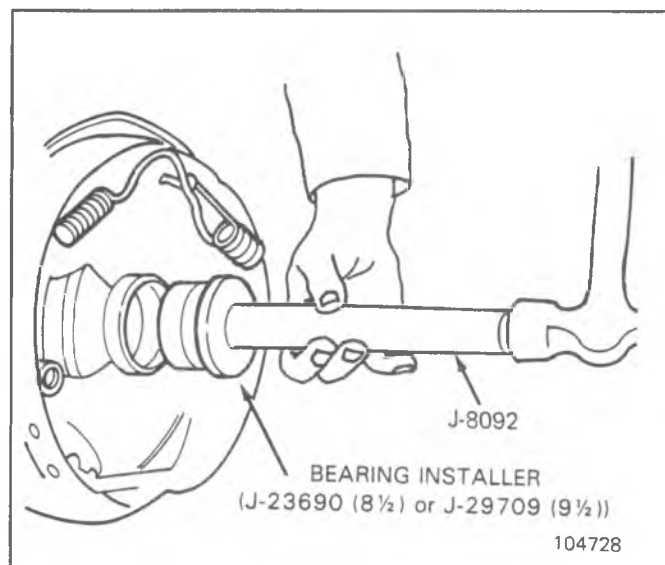

Fig. 4B1-8--Wheel Bearing Installation

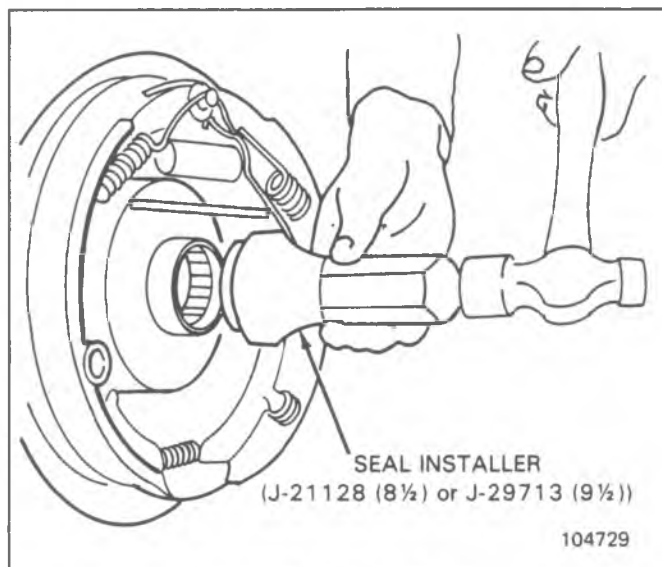

Fig. 4B1-9--Seal Installation

with lock screw hole. A new lock screw must be used when reassembling the differential case.

3. Torque locking screw to 18 N·m (25 ft. lbs.).
4. Using a new gasket, install carrier cover. Make sure both gasket surfaces on carrier and cover are clean before installing new gasket. Torque carrier cover bolts in a crosswise pattern to ensure uniform draw on cover gasket.
5. Fill axle with lubricant as specified in Maintenance and Lubrication Section to a level even with the bottom of filler hole when axle is at operating temperature.
6. Install brake drum and wheel and tire assembly.
7. Lower vehicle and remove from hoist.

#### Brake Backing Plate-Replacement

1. Remove brake line at wheel cylinder inlet and disassemble brake components from flange plate. Refer to the Brake Section for brake disassembly procedure.
2. Remove bolts retaining flange plate to axle, and

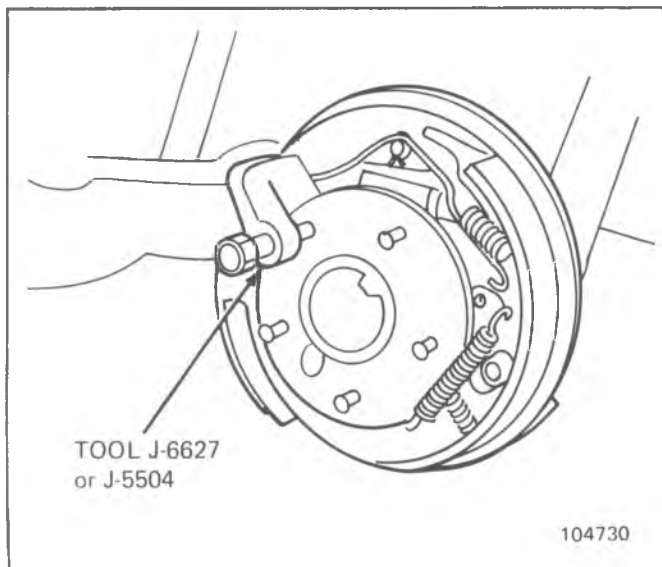

Fig. 4B1-10--Pressing Out Wheel Stud

remove flange plate.

3. Install new flange plate to axle housing and torque nuts to specifications.
4. Install brake components on flange and connect hydraulic line to wheel cylinder inlet. Refer to the Brake Section for brake assembly, bleeding and adjustment procedures.

#### Wheel Bolt-Replacement

1. Raise vehicle on hoist allowing axle to hang freely.
2. Remove wheel and tire and brake drum.
3. Using Tool J-5504 or J-6627 press out stud as shown in figure 4B1-10.
4. Place new stud in axle flange hole. Slightly start stud serrations in hole by firmly pressing back of stud with your hand.
5. Install a lug nut with flat side first (tapered face outboard). Tighten on lug nut drawing stud into flange until stud head is bottomed on back side of flange.
6. Remove lug nut.
7. Reinstall brake drum and wheel and tire.
8. Lower vehicle and remove from hoist.

#### PINION FLANGE, DUST DEFLECTOR

##### AND/OR OIL SEAL

#### Removal

1. Raise vehicle on hoist.
2. Disconnect propeller shaft from axle.
3. Position propeller shaft to one side and tie it to frame side rail.
4. Measure the torque required to rotate the pinion, as shown in figure 4B1-11. Record the torque for later reference.
5. Scribe a line down pinion stem, pinion nut, and flange to aid on reinstallation. Make sure lines show the relationship of components accurately. Count the number of exposed threads on pinion stem, and record for later reference. Refer to figure 4B1-12.

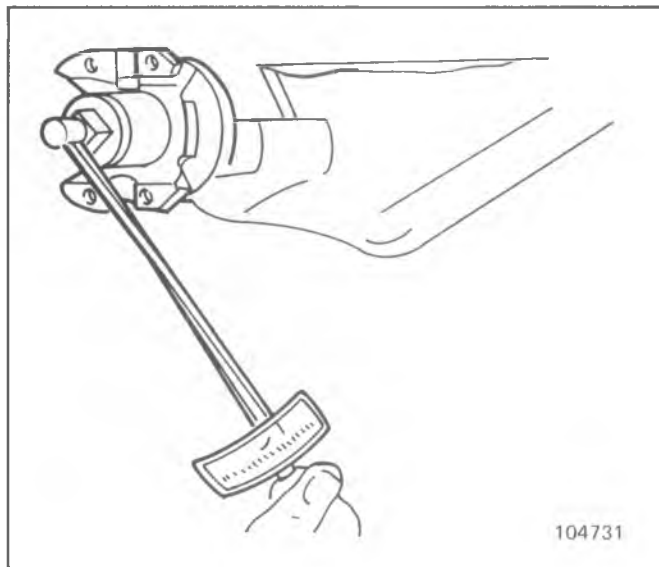

Fig. 4B1-11--Measuring Pinion Rotating Torque

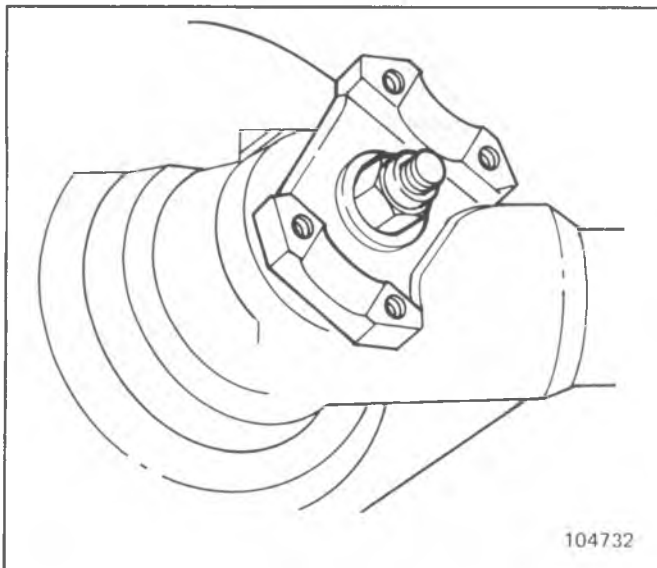

Fig. 4B1-12--Scribe Marks

6. Install Tool J-8614-11 on pinion flange and remove pinion flange self-locking washer faced nut as shown in figure 4B1-13. (Position J-8614-11 on flange so that the four notches are toward flange.) Save scribed nut for reinstallation.
7. Thread pilot end of Tool J-8614-3 into small O.D. end of J-8614-2. Then with J-8614-11 installed as in Step 6, insert J-8614-2 into J-8614-11 and turn it 45 degrees to locked position. Remove flange by turning J-8614-3 while holding J-8614-11 as shown in figure 4B1-14.
8. Pry old seal out of bore, using a screw driver or a hammer and chisel.

#### Inspection

1. Inspect pinion flange for smooth oil seal surface, worn drive splines, damaged ears, and for smoothness of bearing contact surface. Replace if necessary.
2. If deflector requires replacement, remove by tapping from flange, clean up stake points; install new deflector, and stake deflector at three new equally spaced positions.

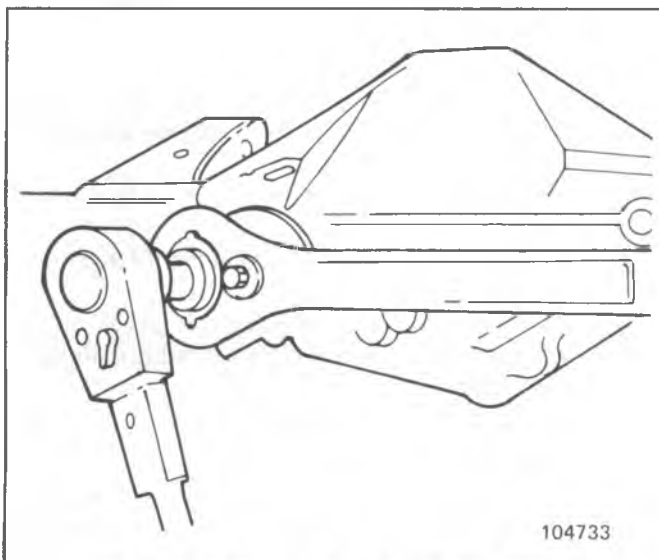

Fig. 4B1-13--Removing Nut from Drive Pinion

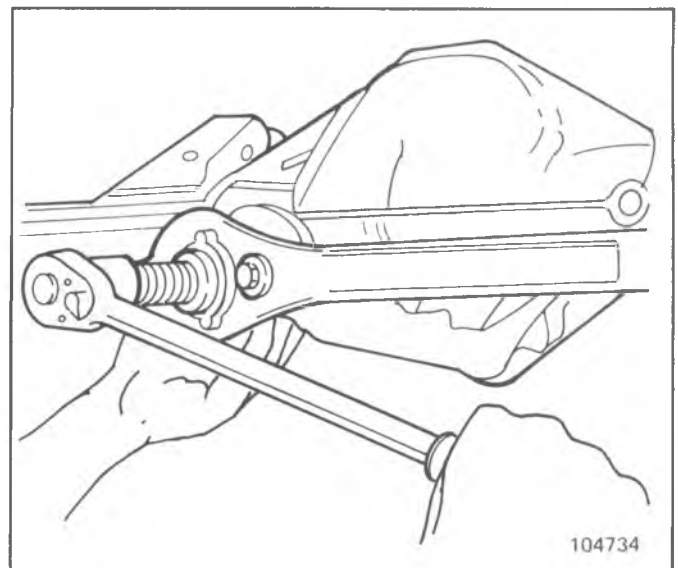

Fig. 4B1-14--Drive Pinion Flange Removal

Staking operation must be performed in such a manner that the seal operating surface is not damaged.

#### Installation

1. Lubricate cavity between the seal lips of the pinion flange oil seal with a lithium-base extreme pressure lubricant.
2. Position seal in bore and place gauge plate J-22804-1 over seal and against seal flange. The gauge plate assures proper seating of seal in carrier bore.
3. Use J-21057 or J-22388 for the 9 1/2 inch ring gear, as shown in figure 4B1-15, to press seal into carrier bore until gauge plate is flush with the carrier shoulder and seal flange. Turn gauge plate 180° from installed position; seal must be square in carrier bore to seal properly against pinion flange.
4. Pack the cavity between end of pinion splines and pinion flange with a non-hardening sealer (such as Permatex Type A or equivalent) prior to installing

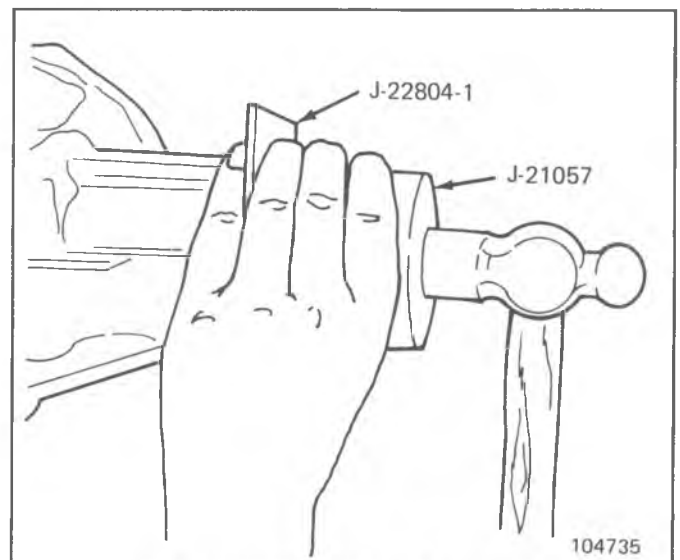

Fig. 4B1-15--Pinion Oil Seal Installation

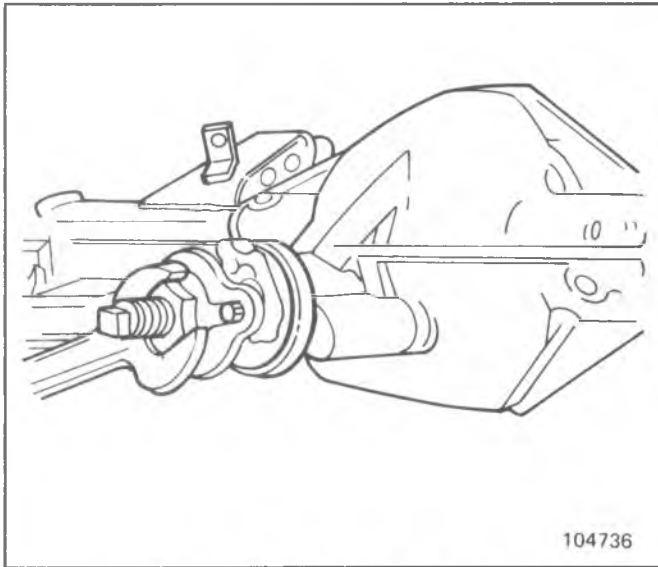

Fig. 4B1-16--Installing Pinion Flange

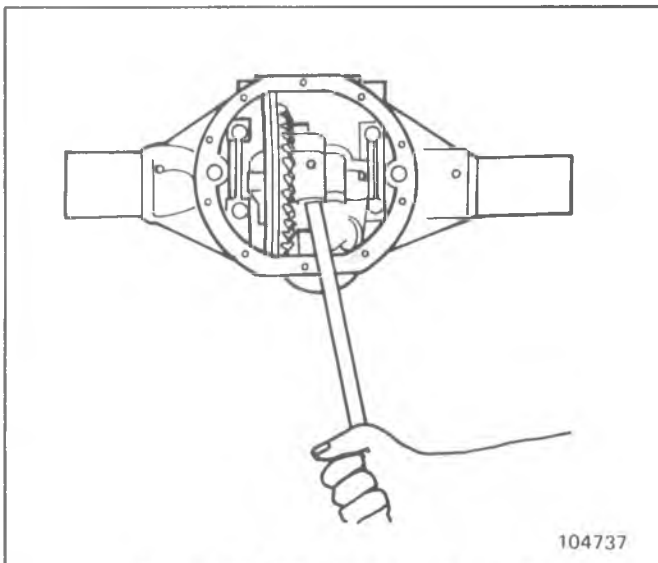

Fig. 4B1-17--Differential Case Removal

If equipped with a locking differential, also refer to Section 4B6.

Before proceeding with following steps, it is advisable to check the existing ring gear to pinion backlash as described under "Operational Checks and Adjustments" (Refer to Section 4B). This will indicate gear or bearing wear or an error in backlash or pinion depth setting which will help in determining cause of axle noise. Backlash should be recorded so that if same gears are reused, they may be reinstalled at original lash to avoid changing gear tooth contact.

1. Remove screw that retains differential pinion shaft, and remove pinion shaft.
2. Remove rear axle shafts.
3. Roll out the differential pinions and thrust washers, then remove side gears and thrust washers. Mark

washer and nut on pinion.

5. Using J-8614-11 as shown in figure 4B1-16, install flange onto pinion. Install washer and nut, and tighten nut to original position. Refer to scribe marks and number of exposed threads, recorded earlier.

**NOTICE:** Do not attempt to hammer the flange onto pinion shaft. To do so may damage the ring gear and pinion.

6. Measure rotating torque of pinion and compare with torque recorded before removal. Tighten pinion nut in additional **small** increments until the torque necessary to rotate the pinion exceeds the original figure by .1-.6 N·m (1-5 in. lbs.). **Do not** exceed the original torque by more than .6 N·m (5 in. lbs.).
7. Reattach propeller shaft and torque to specifications. Reinstall brake drums and wheels.

**NOTICE:** See NOTICE on page 1 of this section regarding the fasteners referred to in step 7.

8. Lower vehicle and remove from hoist.

## UNIT REPAIR

pinions and side gears so that they can be reassembled in original position.

4. Mark the bearing caps and housing for reassembly in same position. Loosen bearing cap bolts. Tap surface of bearing caps to loosen.

**NOTICE:** Do not attempt to pry caps off as this may damage machined face of caps.

5. Using a pry bar as shown in figure 4B1-17, pry differential case out of carrier. Exercise caution in prying on carrier so that gasket sealing surface is not damaged. If the bearings are preloaded, the case will suddenly fall free when it is pried past a certain point; therefore, make sure case is properly supported to prevent damage. The bearing caps may be loosely installed, as shown in figure 4B1-17, to prevent case from falling.
6. Place left and right bearing cups with bearing caps so that they may be reinstalled in original positions. Place shims with appropriate cups.

### Inspection

1. Clean all parts in cleaning solvent; inspect all bearing cups, races and rollers for scoring, chipping or evidence of excessive wear.
2. Inspect axle shaft and side gear splines for evidence of excessive wear.
3. Inspect hypoid ring gear and pinion teeth for possible scoring, cracking or chipping.
4. Inspect differential case, pinions side gears, thrust washers and pinion shaft for cracks, scoring, spalling or excessive wear.
5. Check fit of differential side gears in case.

### Differential Bearing Replacement

1. Install Tool J-22888 and Adapter Plug J-8107-4, J-8107-3 for the 9 1/2" ring gear, assuring puller legs are fitted securely in notches in case and against bearing cone, as shown in figure 4B1-18.

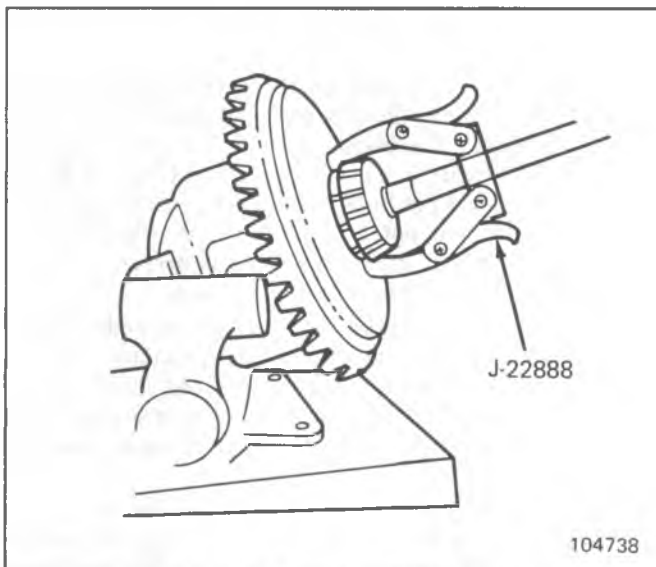

Fig. 4B1-18--Differential Bearing Removal

2. Tighten puller screw to remove bearing.
3. Place new bearing on hub with thick side of inner race toward case and drive into place, using J-22761 for 8-1/2" or J-29710 for the 9 1/2" ring gear and Driver Handle J-8092, as shown in figure 4B1-19.
4. Before bearing installation on opposite hub, support differential case on Adapter Plug J-8107-4 or J-8107-3. This allows differential case to rest on adapter instead of bearing cage. See figure 4B1-19. Install remaining bearing as instructed in step 3.

**Ring Gear or Differential Case Replacement**

1. Remove the ring gear bolts and, using a soft drift and a hammer, tap ring gear off the case.
 

**NOTICE:** Do not attempt to pry ring gear from case. To do so may damage machined surfaces.
2. Remove any nicks or imbedded dirt from case flange surface which mates with ring gear. Clean all surfaces.
3. Liberally coat the differential case pilot with

hypoid lubricant. Pre-align ring gear and differential case bolt holes, and press on adaptor plug J-8107-4 to initially start ring gear on case pilot, as shown in figure 4B1-20.

4. Start all ring gear bolts during initial assembly to maintain bolt hole adlignment. Draw up all bolts evenly, using a criss-cross pattern to avoid cocking the gear on the case.
5. Insure that the gear is seated firmly against the case, then torque the bolts to 145 N·m (105 ft. lbs.) for the 9 1/2" ring gear; 80 N·m (60 ft. lbs.) for the 8 1/2" ring gear.

**Reassembly**

1. Install thrust washers and side gears into case. If original parts are being reused, replace in original positions.
2. Position pinions and thrust washers through loading hole in case 180° apart so they engage side gears.
3. Rotate gears until the differential pinion bores and the case shaft holes are aligned.
4. Install pinion shaft and lock screw. It is not necessary to torque lock screw until axle shafts are installed.
5. Differential may be installed in carrier now, or after service is performed on the drive pinion.

**Installation and Adjustment (8 1/2" Ring Gear)**

1. Check condition of bearing, bearing cups, cup seat in carrier and carrier caps to make sure that they are free from nicks, burrs and foreign material.
2. Lubricate bearings with axle lubricant; position cups on proper bearing, then install differential assembly in carrier and support the assembly to prevent it from falling.
3. Install strap J-22779-6 on left bearing by tightening bearing bolts alternately and evenly to snug fit.
4. With the ring gear tight against the pinion gear (.000" to .001" backlash), insert gaging Tool J-22779 between the left bearing cup and carrier housing as shown in figure 4B1-21.

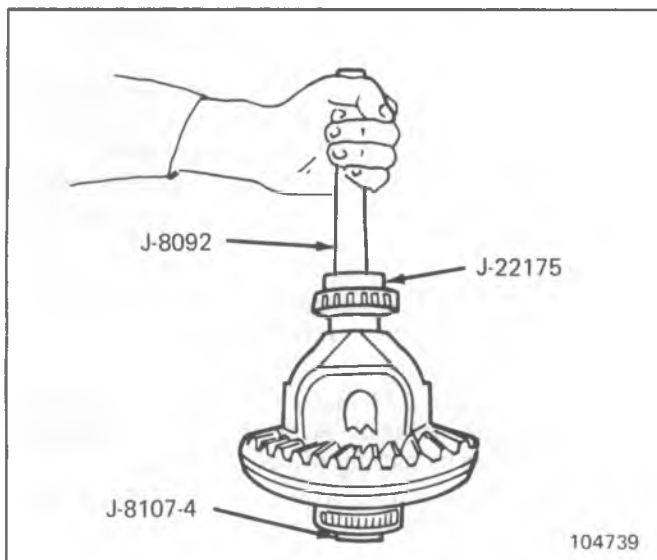

Fig. 4B1-19--Differential Bearing Installation

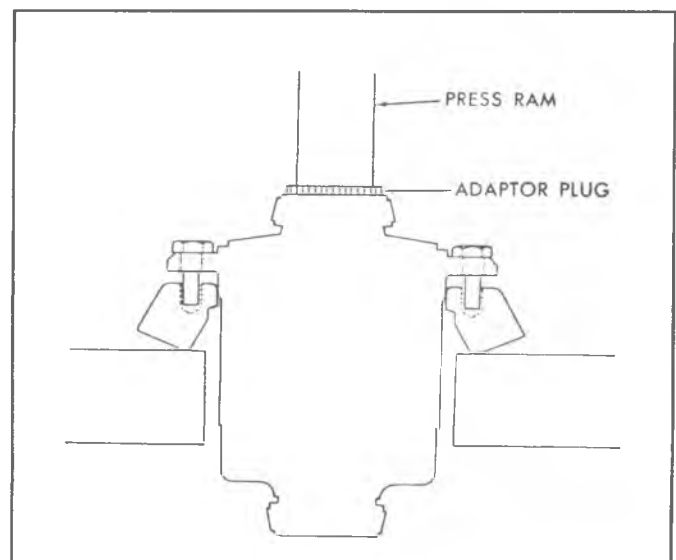

Fig. 4B1-20--Ring Gear-to-Case Installation



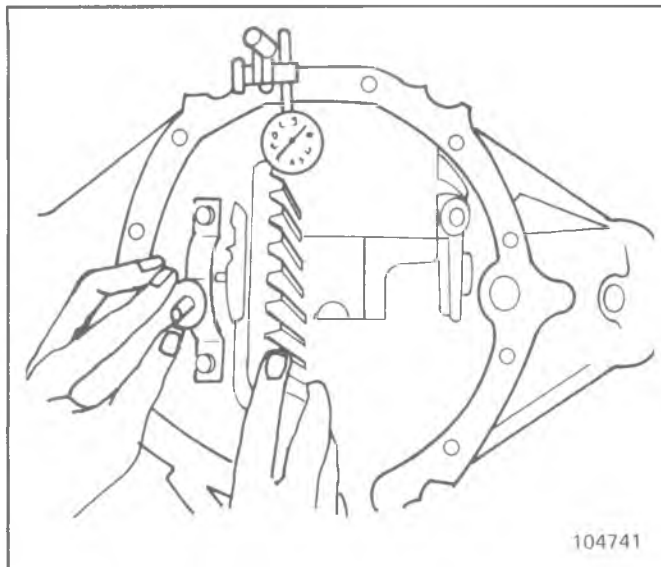

Fig. 4B1-21--Installing Gaging Tool

5. While oscillating tool, turn adjusting nut clockwise until a noticeable drag is produced.
6. Tighten lock bolt on side of tool.
7. Between the right bearing and carrier, install Service Spacer A (.170"), Service Shim B and Feeler Gage C. Thickness of Feeler Gage must be sufficient to produce a slight "drag" when moved between carrier and Service Shim.
8. Now measure the above dimensions as shown in figure 4B1-22.
  - a. Using a micrometer as in figure 4B1-23, measure the thickness of J-22779 in a minimum of three places and average these readings. Record the result.
  - b. Add together the dimensions of the Service Shim, Service Spacer and Feeler Gage. Record the result.
9. Use the sample procedure in figure 4B1-22 to determine the proper thickness for each shim pack.
 

**NOTICE:** Production preloading of the differential bearings is accomplished by the use of cast iron preload shim. These shims cannot be used when rebuilding the carrier as they may break when tapped into place.
10. Install left shim first, then wedge right shim between bearing cup and spacer. Position shim so that chamfered side is outward or next to spacer. If shim does not have sufficient chamfer or lead around O.D. to allow easy installation without scraping spacer, file or grind chamfer before installing.
11. If difficulty is encountered in installing shim, partially remove case and slide case and shim into position. Tap shim into position, using a soft faced hammer, while rotating differential case with free hand as shown in figure 4B1-24.
12. Install bearing caps in original position and torque to 80 N·m (60 ft. lbs.).
 

At this point, the differential side bearings are properly preloaded. If any adjustments are required in later procedures, make sure the preload remains as

established in step 9. If backlash is changed in later steps, be sure the **total** thickness of the two shim packs does not change.

13. Mount a dial indicator on the carrier and check the backlash between the ring gear and pinion, as shown in figure 4B1-25. The backlash should be within the range of 0.005" - 0.008". Check gear lash at four different equally spaced positions around the gear. Variation in readings should not exceed .001". Position the dial indicator so that indicator button is perpendicular to tooth angle and in line with gear rotation.
14. If variation in backlash readings exceeds .002"; measure ring gear and case runout as shown in figure 4B1-26. Gear runout should not exceed .003"; should runout exceed this limit, check ring gear and case for deformation and/or foreign matter between case and gear.
15. If gear lash is not within limits, correct by decreasing shim thickness on one side and increasing thickness of other shim **the same amount**. Total shim thickness must be maintained at all times to maintain proper preload.
16. Backlash changes approximately .002" for each .003" change in shim dimensions.
  - If backlash exceeds .008", increase the shim thickness on the ring gear side, while decreasing the shim thickness on the opposite side **an equal amount**.
  - If backlash is less than .005", decrease the shim thickness on the ring gear side, while increasing the shim thickness on the opposite side **an equal amount**.

#### Differential Backlash Adjustment (9 1/2" Ring Gear)

1. Place bearing cups over side bearings and lift the differential assembly into the carrier.
2. Install bearing shim.
3. Push case towards bearing shim side of carrier.
4. Tighten adjusting nut using tool J-24429 and rotate pinion to seat bearings as shown in Fig. 4B1-27.
5. Back adjusting nut off and install bearing cups loosely.
6. Turn adjusting nut until initial contact and index 3 additional slots.
7. Install bearing caps to 80 N·m (70 ft. lbs.).
8. Install locking retainers into holes and attach fingers to bearing cap loosely.
9. At this time, the differential bearings are properly preloaded. If any additional adjustment is required, make sure that the preload remains established.
10. Mount a dial indicator on the housing and measure backlash between the ring gear and pinion. Backlash should be .075 mm - .25 mm (.003 - .010) with .125 mm - .20 mm (.005 - .008) preferred.
11. If reading is too high, increase bearing shim size. If reading is too low, decrease bearing shim size.
12. Torque locking retainer to 30 N·m (20 ft. lbs.).

A service spacer 5.34 mm (.171) thick is available. Service shims are available from 1.278 - 2.256 mm (0.50 - .088) in increments of .050 mm (.002).

Pinion shims are available from .5080 - .9398 mm (.020 - .037) in increments of .025 mm (.001).



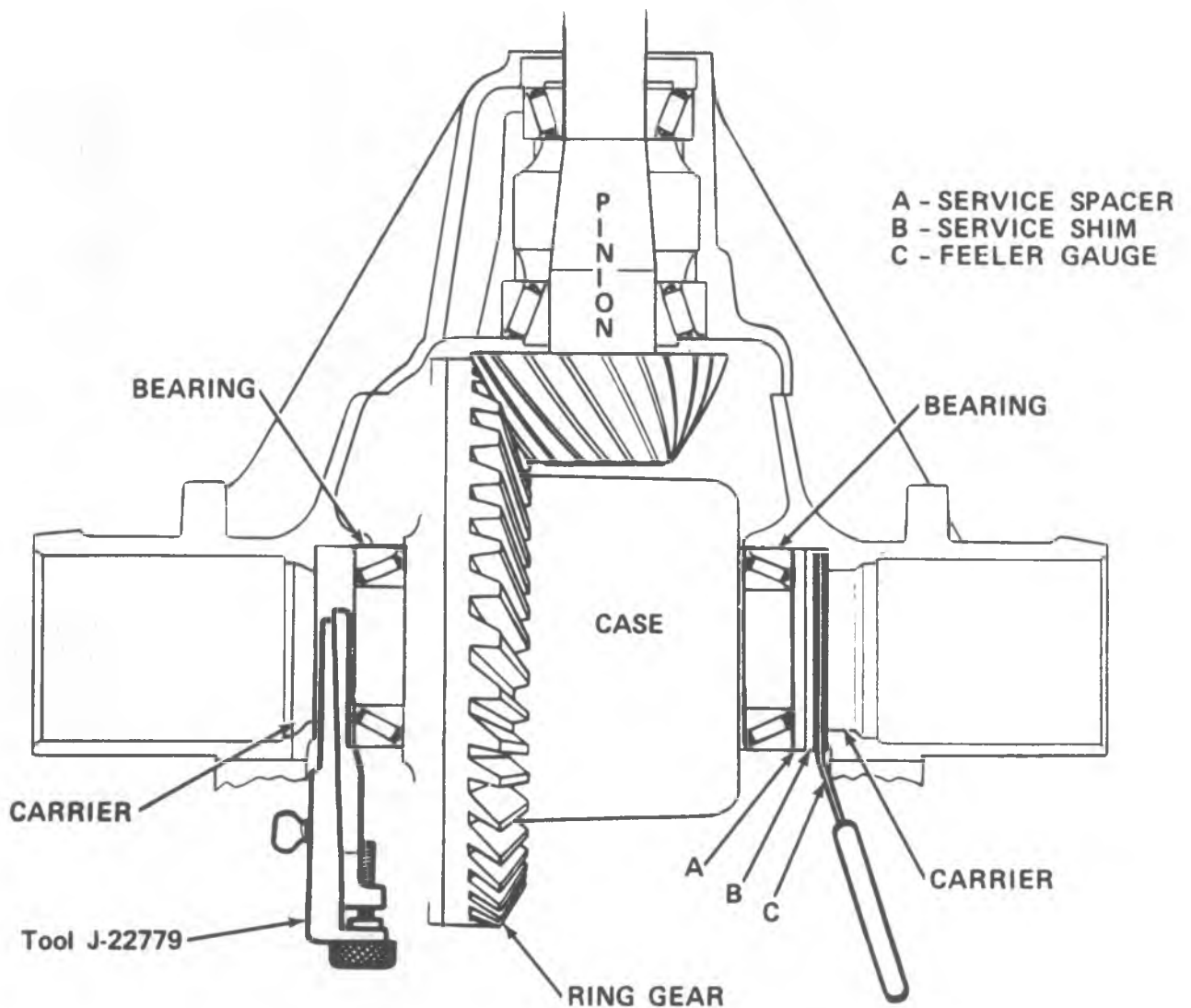

EXAMPLE

RING GEAR SIDE

OPPOSITE SIDE

.250"

Thickness of Tool J-22779 required to force ring gear into contact with pinion

Combined total of:

Service Spacer (A)  
Service Shim (B)  
Feeler Gauge (C)

.265"

$-\frac{.010''}{.240''}$

TO MAINTAIN PROPER BACKLASH (.005" - .008"), ring gear is moved away from pinion by subtracting .010" shims from ring gear side and adding .010" shims to other side

$+\frac{.010''}{.275''}$

$+\frac{.004''}{}$

TO OBTAIN PROPER PRELOAD on side bearings, add .004" shims to each side.

$+\frac{.004''}{}$

.244"

Shim dimension required for ring gear side

Shim dimension required for opposite side

.279"

Fig. 4B1-22--Determining Side Bearing Shim Requirements

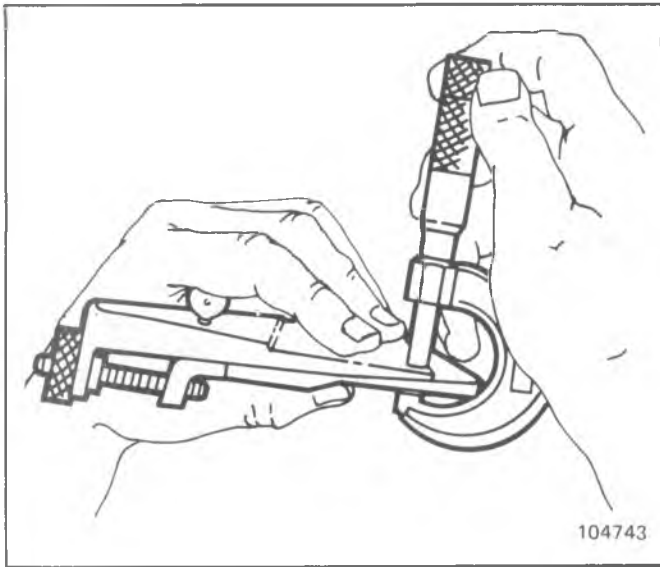

Fig. 4B1-23--Measuring Gage Plate Thickness

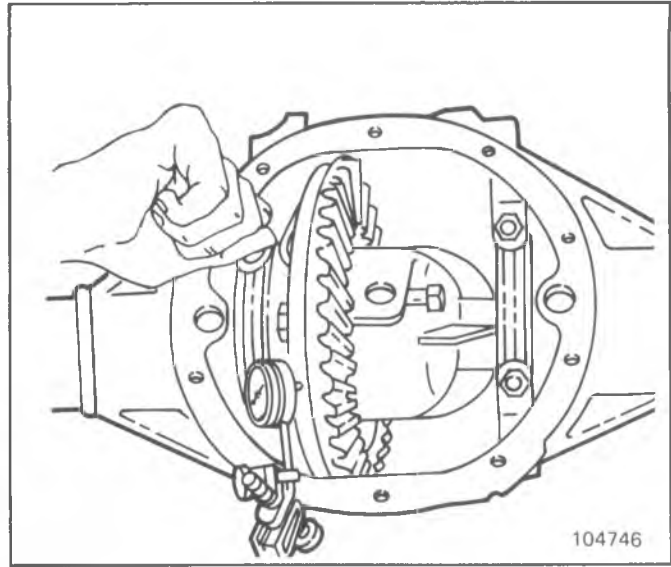

Fig. 4B1-26--Checking Ring Gear Runout

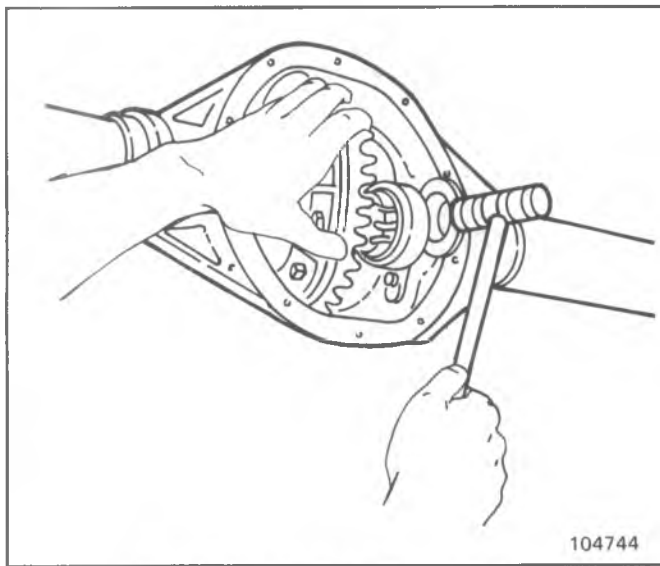

Fig. 4B1-24--Installing Differential Shim

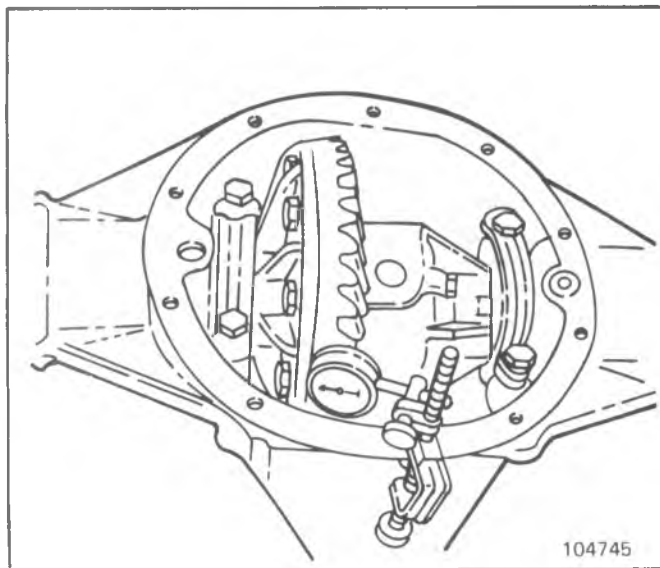

Fig. 4B1-25--Checking Ring Gear Backlash

## DRIVE PINION

### Removal

1. Remove differential as previously outlined.
2. Check torque required to rotate drive pinion, as described under "Drive Pinion - Installation and Adjustment". If there is no preload reading, check for looseness of pinion assembly by shaking (push-pull) the companion flange. Looseness indicates the need for bearing replacement.
3. Install Holder J-8614-11 on flange by using two bolts with flat washers, as shown in figure 4B1-28. Position J-8614-11 on flange so that the four notches are toward the flange.
4. Remove pinion nut and washer.
5. Thread end of J-8614-3 into small O.D. end of J-8614-2. Then with J-8614-11 installed as in step 3, insert J-8614-2 into J-8614-11 and turn it 1/8 of a turn to locked position. Remove flange by turning J-8614-3 while holding J-8614-11 as shown in figure 4B1-29.

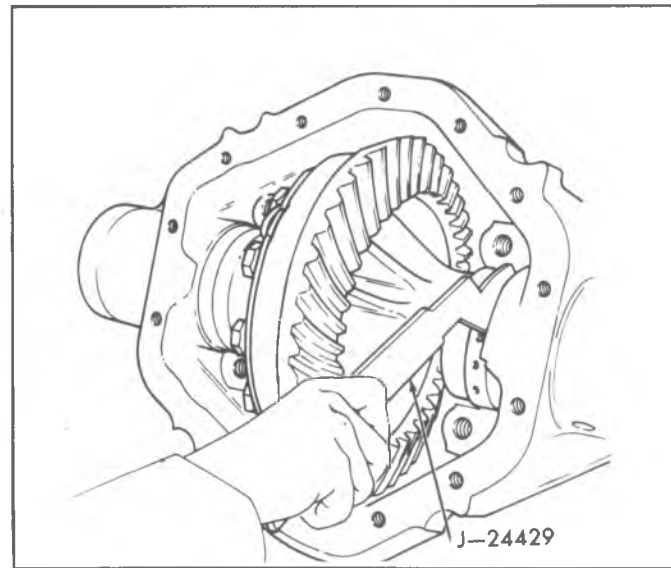

Fig. 4B1-27--Loosening Adjusting Nut

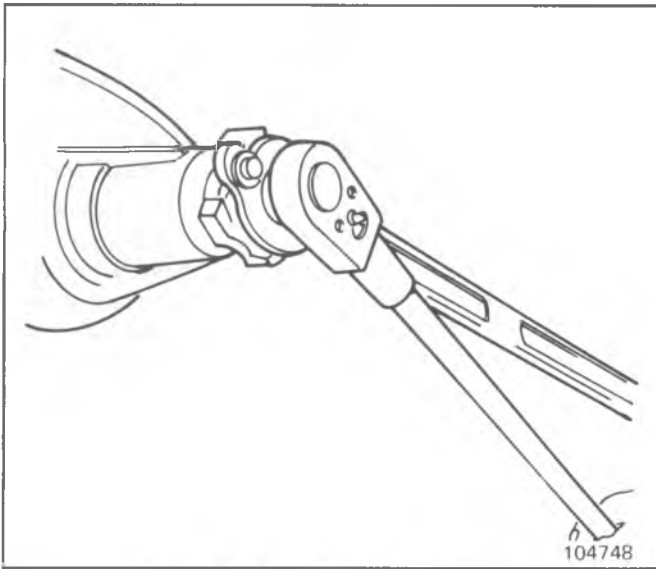

Fig. 4B1-28--Drive Pinion Nut Removal

6. To remove the drive pinion, first thread the original pinion nut half way on the pinion, for thread protection.
7. Place the differential cover temporarily back onto the housing, using two screws. This will prevent the pinion from falling to the floor during removal.
8. Tap the end of the pinion nut with a large hammer and a soft drift, as shown in figure 4B1-30.  
Care must be taken not to damage pinion bearings while removing pinion from carrier. Inspect bearings and cups for damage and replace if needed.
9. Remove the pinion oil seal and the front pinion bearing. Remove the cover and retrieve the drive pinion from the housing. Discard the pinion oil seal, nut, and collapsible spacer. Use a new oil seal, nut and spacer on reassembly.

**Bearing Removal and Cup Replacement**

1. If front pinion bearing is to be replaced, drive outer race from carrier using a drift in slots

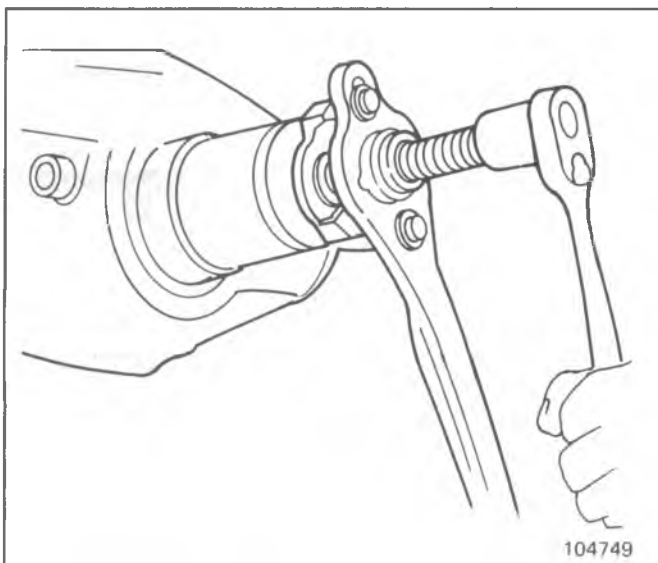

Fig. 4B1-29--Drive Pinion Flange Removal

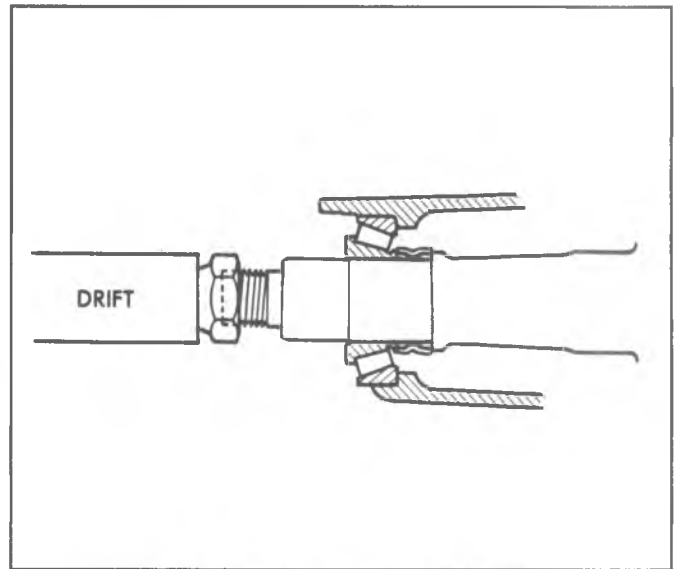

Fig. 4B1-30--Removing Drive Pinion

2. If rear pinion bearing is to be replaced drive outer race from carrier using a drift in slots provided for this purpose.
3. Remove rear pinion bearing from pinion shaft using press plate J-8612 for 8-1/2" ring gear and J-22912-01 for 9 1/2" ring gear as shown in Figure 4B1-31.  
Tighten nuts on tool until plates are under the bearing inner race. Then set the tool on a press. Make sure the plates straddle the opening on the press. Do not position bolts across the opening. To do so may bend the bolts when pressure is applied. Press bearing from pinion. Record the thickness of shim removed from between bearing and pinion head.
4. Inspect carrier pinion bearing bores and shoulders for nicks. Remove as necessary. Clean the bores and the installation tools.
5. Lubricate both bearing cups with liberal amounts of

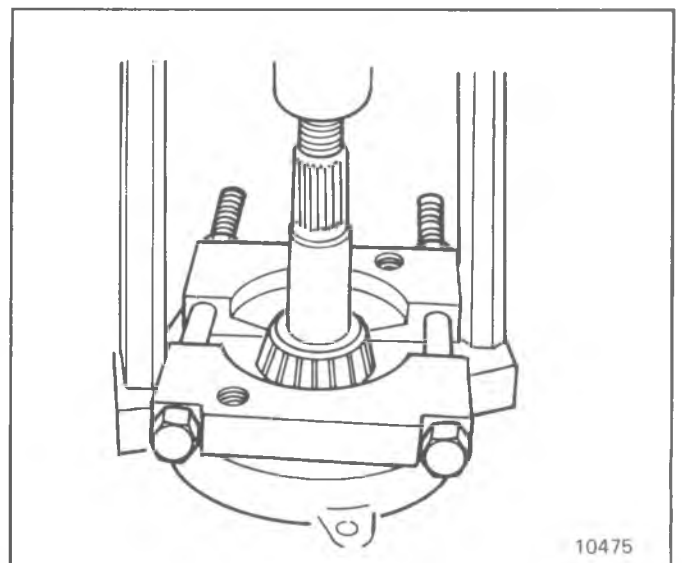

Fig. 4B1-31--Removing Drive Pinion Rear Bearing

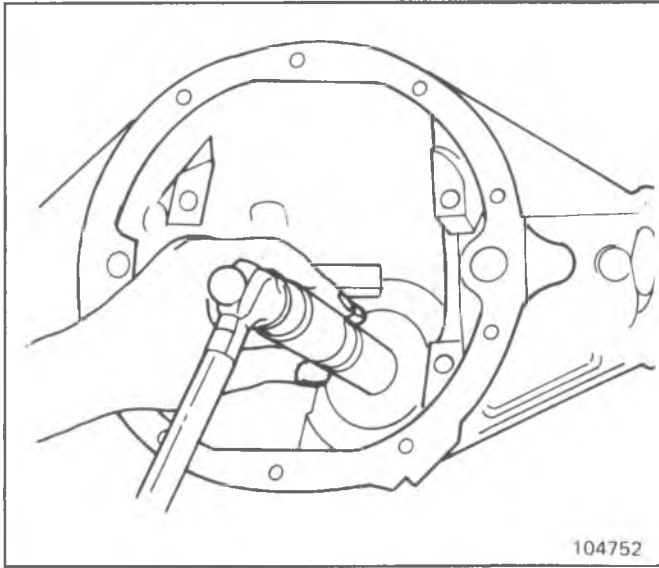

Fig. 4B1-32--Installing Pinion Rear Bearing Cup

hypoid lubricant.

6. Install the rear cup, with the large end against the bore shoulder, using Installer J-8608 for 8-1/2" ring gear and J-22306 for the 9 1/2" ring gear as shown in figure 4B1-32.
7. Install the front cup, with the large end against the bore shoulder, using Installer J-8611-01 for the 8-1/2" ring gear and J-7818 for the 9 1/2" ring gear as shown in figure 4B1-33.
8. Check both bores to make sure cups are fully seated.

#### Setting Pinion Depth and Installing Pinion Bearings

If the original ring gear and pinion and the pinion rear bearing assembly are to be reinstalled, the original shim thickness may be used.

Ring and pinion gear sets are matched in a special test machine which permits adjustment of pinion depth in ring gear until a point is reached where best operation and proper tooth contact under load is obtained. At this point, the setting of the pinion with reference to the centerline

of the ring gear is indicated by the machine. This setting may vary slightly from the design or "nominal" setting due to allowable variation in machining the parts. When a pinion is found having a plus or minus reading recorded in thousandths on the rear face of the pinion, this indicates that the pinion during testing was found to have best tooth contact at a position varying from design or nominal depth.

In order to compensate for all of the allowable machining variables, a procedure of gaging the carrier and shimming the pinion has been developed. After gaging a carrier, the assembler must install the appropriate shim between the drive pinion shoulder and rear bearing so that pinion depth can be adjusted to the required position for best tooth contact in each axle assembly.

Proper pinion depth is determined with Pinion Setting Gage J-21777-01.

1. Clean the housing assembly and all gage parts to insure accurate measurements.
2. Lubricate front and rear pinion bearings which will be used in final assembly and position them in their respective races in the carrier.
3. Use cloverleaf gage plate J-21777-29 for 8-1/2" ring gear and J-21777-85 for 9 1/2" ring gear mounted on preload stud J-21777-43 insert stud through rear bearing and pilot J-21777-35, or J-21777-8 for the 9 1/2" ring gear. and through front bearing and pilot J-21777-42. Install the hex nut until snug and rotate the bearings to make sure they are properly seated. See figure 4B1-34 for illustration of proper positioning.
4. Hold the preload stud stationary with a wrench on the flats and tighten hex nut. Tighten until 2.2 N·m (20 in. lbs.) of torque are required to rotate the bearings, as shown in figure 4B1-35.
5. Mount the side bearing discs J-21777-45 or J-21777-86 on the ends of arbor J-21777-1, using the step of the disc that corresponds to the bore of the carrier.
6. Place the arbor and plunger assembly into the carrier, being sure the side bearing discs are seated properly.
7. Install the bearing caps finger tight to hold the

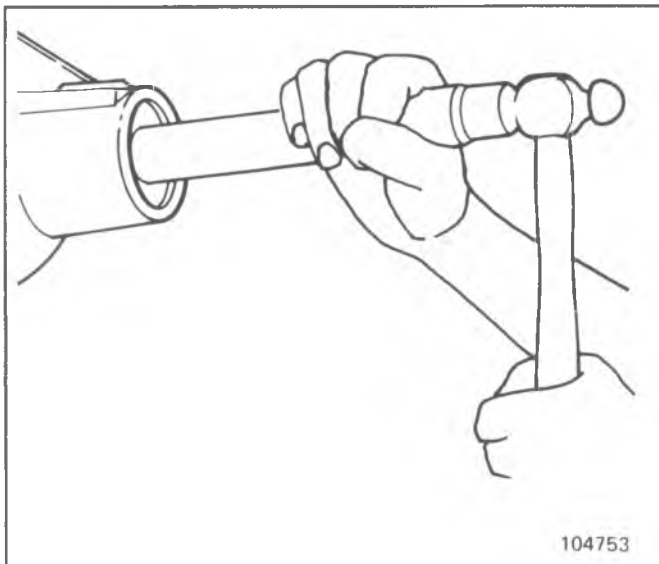

Fig. 4B1-33--Installing Pinion Front Bearing Cup

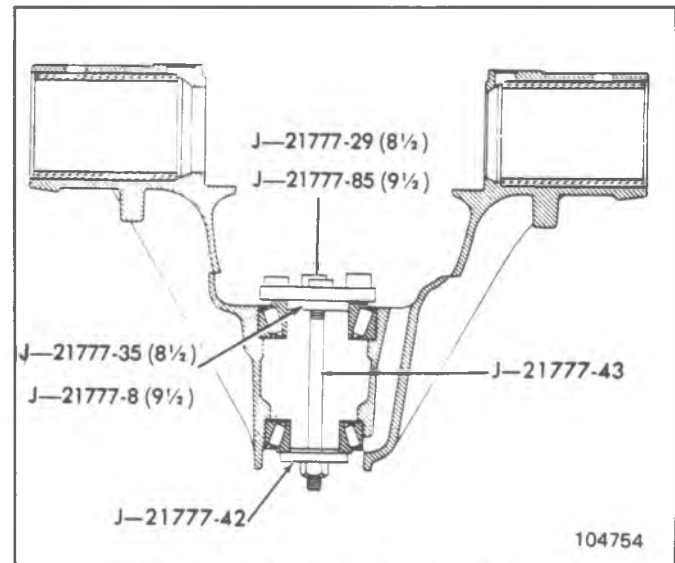

Fig. 4B1-34--Gage Plate Installed

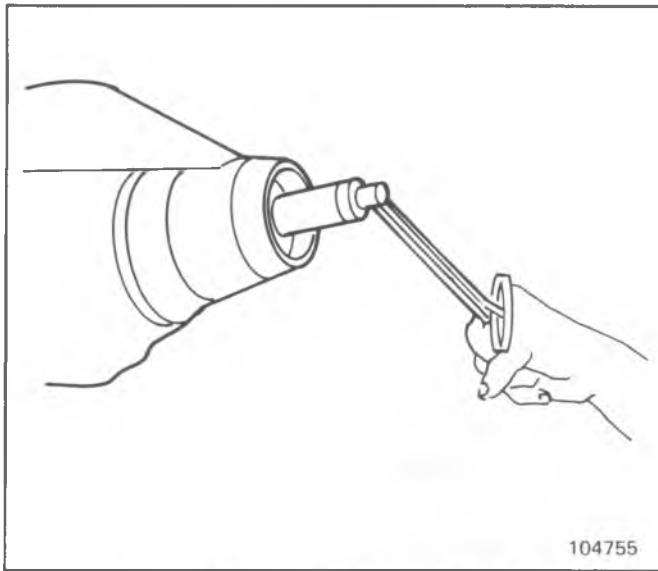

Fig. 4B1-35--Measuring Rotating Torque

- discs from movement.
8. Position dial indicator J-8001 on the mounting post of the arbor with the contact button resting on the top surface of the plunger.
  9. Preload the dial indicator one-half revolution, and tighten in this position.
  10. Select the button on the gage plate or gage block that corresponds to the ring gear size and rotate the plate until the plunger rests directly upon that button.
  11. Rock the plunger rod slowly back and forth across the button until the dial indicator reads the greatest deflection. At this point, set the dial indicator to zero. Tools will now be positioned as shown in figure 4B1-36.

It is important to use a dial indicator correctly when determining pinion depth requirements. Be sure to record the number indicated by the indicator needle; do not record the amount of travel of the needle.

After "zeroing" the dial indicator on the highest point of deflection on the gauge plate, the indicator probe is swung off the gauge plate, allowing the needle to move. The number which the needle points toward is the correct shim thickness required for a nominal pinion (Fig. 4B1-37).

12. Repeat the rocking action of the plunger several times to verify the setting.
13. Once the zero reading is obtained, swing the plunger until it is removed from the gaging plate button. The dial indicator will now read the required pinion shim thickness for a "nominal" pinion. Record this figure.
14. Check the rear face of the drive pinion being installed for a pinion code number. This number indicates the necessary alteration of the pinion shim thickness as determined in step 13.

a. If the pinion is stamped with a plus (+) number, **add** that many thousandths to the indicator reading. For

example, if indicator reading is .019, and pinion is marked (+2), the correct depth shim for installation will be  $.019 + .002 = .021$  inch.

- b. If the pinion has no plus (+) or minus (-), use the indicator reading as the correct shim thickness.
  - c. If the pinion is stamped with a minus (-) number, **subtract** that many thousandths from the indicator reading. For example, if the indicator reading is .031, and pinion is marked (-3), the correct depth shim for installation will be  $.031 - .003 = .028$  inch.
15. Remove bearing caps and depth gaging tools from carrier.
  16. Position the shim selected in step 14 on the pinion shaft against pinion head.
  17. Lubricate the rear pinion bearing with liberal amounts of hypoid lubricant and install rear bearing. Use J-8609-01 for the 8-1/2" ring gear and J-6547 for the 9 1/2" ring gear, as shown in figure 4B1-38.

#### Installation and Adjustment

1. Lubricate the front bearing with liberal amounts of hypoid lubricant, and place into outer cup.
2. For 8-1/2" ring gear place a new seal into position in carrier bore. Tap lightly with a protective plate and a hammer until seal flange seats against carrier. For 9-1/2" ring gear use tool J-22388 pinion seal installer.
3. Coat lips of pinion oil seal and seal surface of pinion flange with hypoid lubricant.
4. Install a new pinion bearing spacer onto drive pinion.
5. Place drive pinion into position, and mount a suitable thick washer or sheet metal plate over the pinion stem. Install the original pinion nut and tighten sufficiently to draw pinion through the front bearing far enough to leave threads exposed when the companion flange is placed into position. Remove the washer and install the companion flange, using J-8614-11.

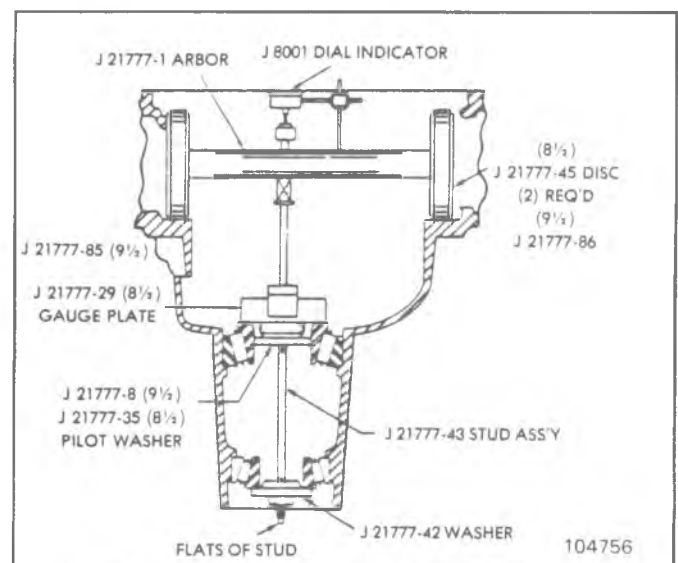

Fig. 4B1-36--Gaging Tools Installed in Carrier

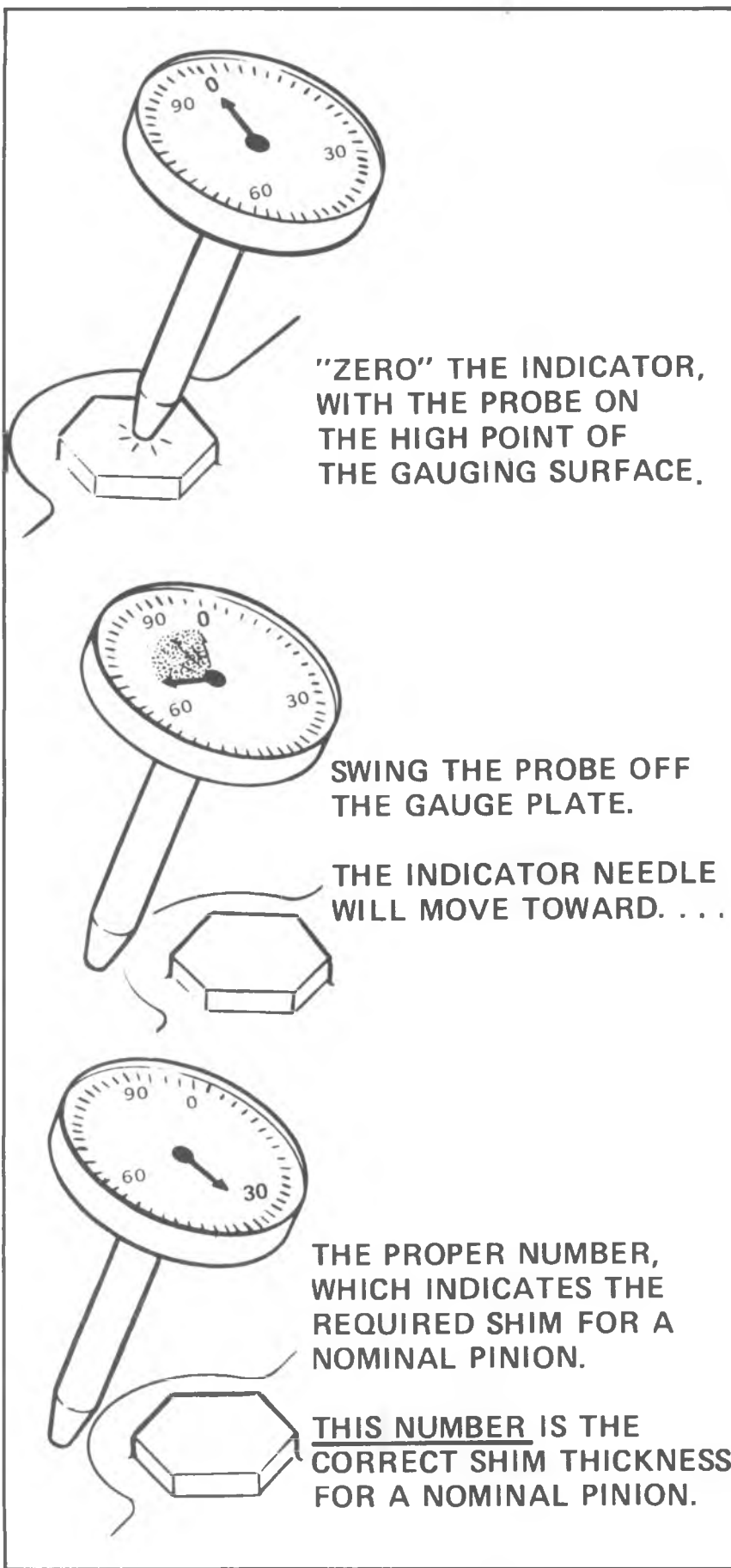

Fig. 4B1-37--Use of Dial Indicator

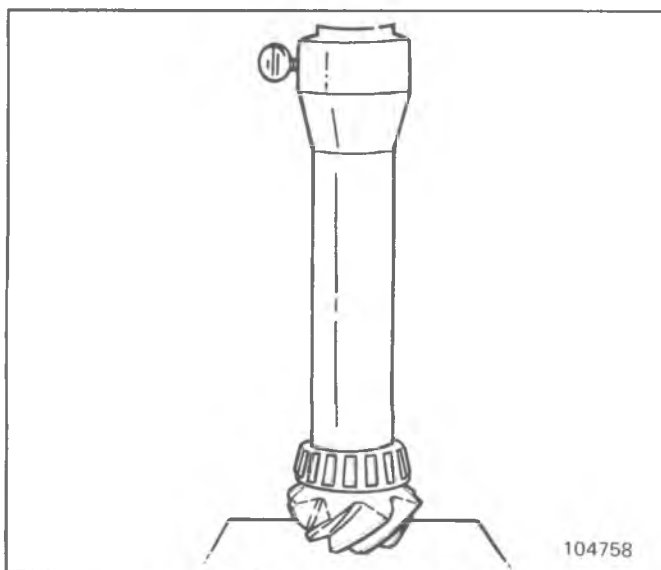

Fig. 4B1-38--Installing Rear Bearing

6. Tighten nut until all end play is removed from drive pinion.

When no further end play is detectable, and when Holder J-8614-11 will no longer pivot freely as pinion is rotated, preload specifications are being neared. Further tightening should be done only after nut and washer installation and preload has been checked.

7. While observing the preceding caution, carefully set preload drag at 20-25 inch pounds on new bearings, or 10-15 inch pounds on reused bearings. Use an inch-pound torque wrench such as J-5853 as shown in figure 4B1-40, to measure the rotating torque.

After torque has been checked, final tightening should be done very carefully. For example, if when checking, torque was found to be 5 inch-pounds, additional tightening of the pinion nut as little as 1/8 turn can add 5 additional inch pounds drag. Therefore, the pinion nut should be further tightened only a little at a time and torque should be checked after each slight amount of tightening. Exceeding torque specifications

may compress the collapsible spacer too far and require its replacement.

8. Rotate the pinion several times to assure that bearings have been seated. Check preload again. If drag has been reduced, re-set preload to specifications.

### OPERATIONAL CHECKS AND ADJUSTMENTS

Four adjustments are essential for proper operation of the differential and its related parts. These adjustments are a) Pinion Bearing Preload, b) Side Bearing Preload, c) Pinion Depth and d) Ring Gear-to-Pinion Backlash.

Refer to Section 4B for description of how to perform these checks and adjustments.

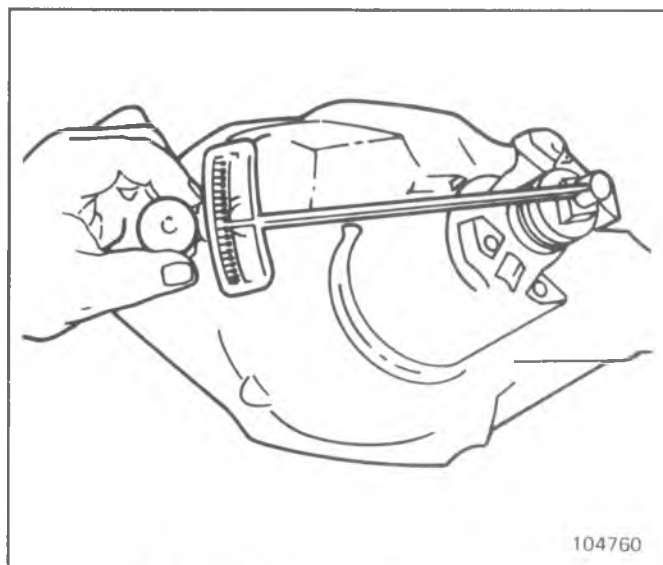

Fig. 4B1-40--Measuring Rotating Torque

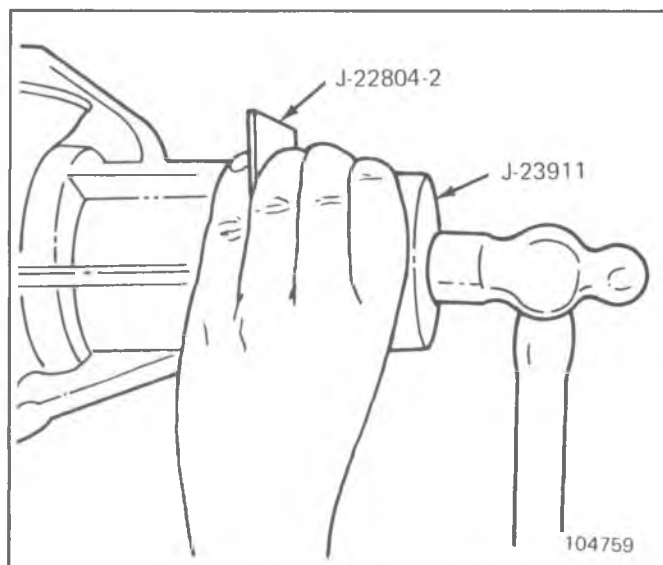

Fig. 4B1-39--Installing Pinion Oil Seal





## SECTION 4B2

# CHEVROLET 10-1/2" RING GEAR AXLE

The following notice applies to one or more steps in the assembly procedure of components in this portion of the manual as indicated at appropriate locations by the terminology "See Notice on Page 1 of this Section".

**NOTICE:** This fastener is an important attaching part in that it could affect the performance of vital components and systems, and/or could result in major repair expense. It must be replaced with one of the same part number or with an equivalent part if replacement

becomes necessary. Do not use a replacement part of lesser quality or substitute design. Torque values must be used as specified during reassembly to assure proper retention of this part.

### CONTENTS

|  |       |  |       |
|--|-------|--|-------|
| On-Vehicle Service . . . . .               | 4B2-1 | Side Bearing Replacement . . . . .           | 4B2-5 |
| Axle Shaft . . . . .                       | 4B2-1 | Ring Gear Replacement . . . . .              | 4B2-5 |
| Hub and Drum . . . . .                     | 4B2-2 | Disassembly and Reassembly . . . . .         | 4B2-5 |
| Drum Non-Demountable Type . . . . .        | 4B2-3 | Installation and Adjustment . . . . .        | 4B2-6 |
| Axle Shaft Bearing . . . . .               | 4B2-2 | Drive Pinion . . . . .                       | 4B2-6 |
| Wheel Bolts . . . . .                      | 4B2-3 | Removal . . . . .                            | 4B2-6 |
| Bearing Adjustment . . . . .               | 4B2-4 | Disassembly . . . . .                        | 4B2-6 |
| Pinion Oil Seal/Companion Flange . . . . . | 4B2-4 | Inspection . . . . .                         | 4B2-7 |
| Unit Repair . . . . .                      | 4B2-4 | Reassembly . . . . .                         | 4B2-7 |
| Differential Case . . . . .                | 4B2-4 | Installation and Adjustment . . . . .        | 4B2-9 |
| Removal . . . . .                          | 4B2-4 | Operational Checks and Adjustments . . . . . | 4B2-9 |

## ON-VEHICLE SERVICE

Service operations on these axle assemblies may be performed with the housing installed in the vehicle or with the housing installed in a holding fixture. There may be occasions, however, when it will be necessary to remove the complete housing assembly. The following axle assembly removal and installation procedure, therefore, is necessary only when housing replacement is required.

**NOTICE:** All axle attachments are important attaching parts. See NOTICE on page 1 of this section.

### Removal

1. Raise vehicle, place stand jacks under frame side rails, and remove rear wheels.
2. Remove two trunnion bearing "U" bolts from the rear yoke, split rear universal joint, position propeller shaft to one side, and tie it to the frame side rail.

The bearings can be left on the trunnion and held in place with tape.

3. Remove hub and drum assembly and disconnect parking brake cable at lever and at flange plate. See Section 5 for cable removal.
4. Disconnect hydraulic brake hose at connector on rear axle housing. Refer to Section 5.
5. Disconnect shock absorbers at axle brackets.
6. Support axle assembly with hydraulic jack, remove spring "U" bolts, and lower axle assembly to the floor.

### Installation

1. Place axle assembly under vehicle, raise into position, install spring "U" bolts, anchor plates and nuts, and tighten securely.
2. Connect and secure shock absorbers to axle brackets.
3. Connect brake hose at connector on rear axle housing.
4. Connect parking brake cable at lever and flange plate. Install hub and drum assembly. Bleed brake hydraulic system and adjust parking brake.  
Before reinstalling wheel hub and drum assembly replace hub oil seal.
5. Reassemble the rear universal joint, making sure that "U" bolts are drawn up tight and locked properly. Caution should be taken not to overtighten "U" bolt nuts and cause bearing cups to become distorted.
6. Install rear wheels, remove stand jacks, and lower vehicle.
7. Test operation of brakes and rear axle.

### AXLE SHAFT

#### Replacement

1. Remove bolts that attach the axle shaft flange to the wheel hub. See figure 4B2-1.
2. Rap on flange with a soft-faced hammer to loosen shaft. Grip the rib on end of flange with a pair of locking pliers and twist to start shaft removal.

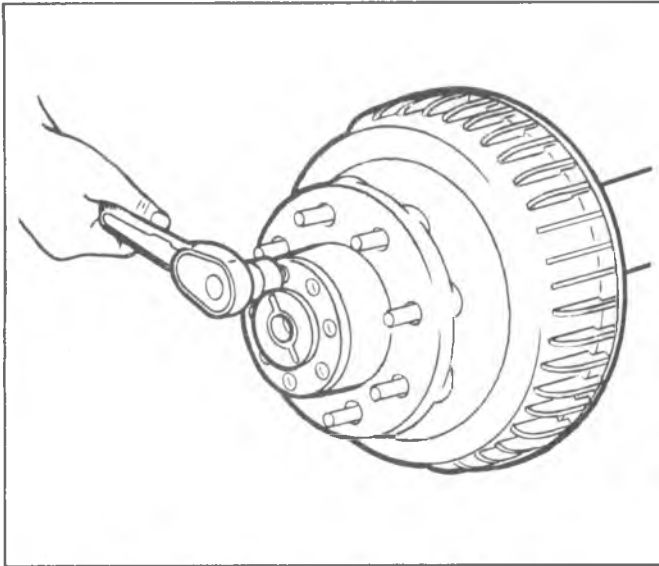
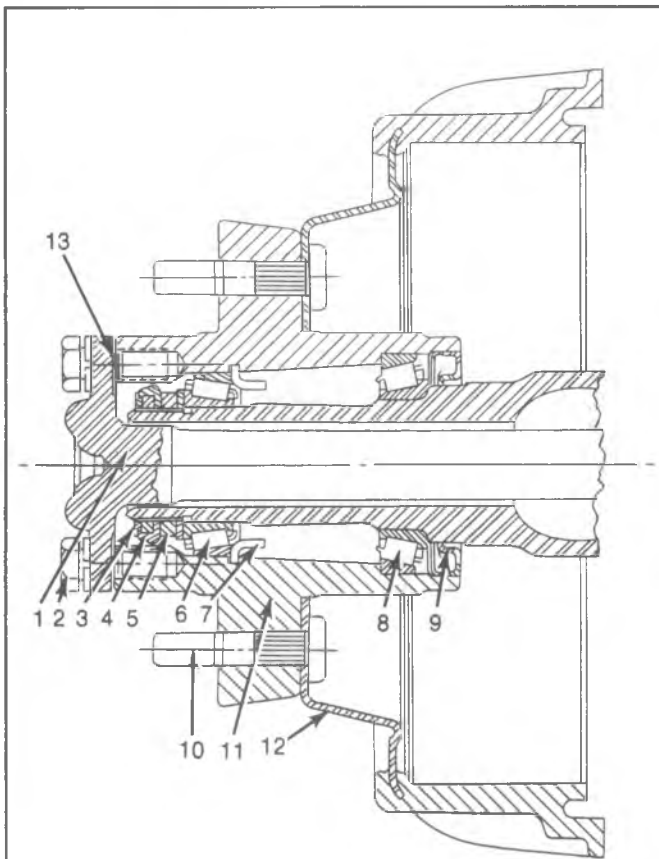

Fig. 4B2-1--Removing Flange-to-Hub Bolts



- |                      |                      |
|----------------------|----------------------|
| 1. Axle Shaft        | 8. Hub Inner Bearing |
| 2. Shaft-to-Hub Bolt | 9. Oil Seal          |
| 3. Retainer          | 10. Wheel Bolt       |
| 4. Key               | 11. Hub Assembly     |
| 5. Adjusting Nut     | 12. Drum Assembly    |
| 6. Hub Outer Bearing | 13. R.T.V.           |
| 7. Snap Ring         |                      |

Fig. 4B2-2--Hub and Drum Assembly-10-1/2" Axle

Remove shaft from axle tube.

3. Thoroughly clean both the axle shaft flange and the end of the wheel hub. Any lubricant on these surfaces tends to loosen axle shaft flange bolts.
4. Place a new gasket over the axle shaft and position the axle shaft in the housing so that the shaft splines enter the differential side gear. Position gasket so that holes are in alignment and install flange-to-hub attaching bolts. Torque bolts to specifications.

**HUB AND DRUM ASSEMBLY-FIG. 4B2-2**

**Removal**

1. Remove axle shaft as outlined earlier.
2. Disengage tang of retainer from slot or flat of locknut, then remove locknut from housing tube, using J-2222, as shown in figure 4B2-3.
3. Disengage tang of retainer from slot or flat of adjusting nut and remove retainer from housing tube.
4. Use appropriate tool as specified in Step 2 to remove adjusting nut from housing tube. Remove thrust washer from housing tube.
5. Pull hub and drum assembly straight off axle housing.
6. Remove oil seal, and discard.

**Bearing /Cup-Removal**

1. Use a hammer and long drift to knock the **inner** bearing, cup and oil seal from the hub assembly.
2. Remove **outer** bearing snap ring with a pair of pliers.
3. With J-24426 on Handle J-8092, as shown in figure 4B2-4, drive **outer** bearing and cup from the hub assembly.

**Inspection and Cleaning of Bearings**

1. Inspect bearing rollers for excessive wear, chipped edges, and other damage. Slowly move rollers around cone to detect any flat or rough spots on rollers or cone.
2. Examine bearing cups in hub for pits, cracks and other damage.

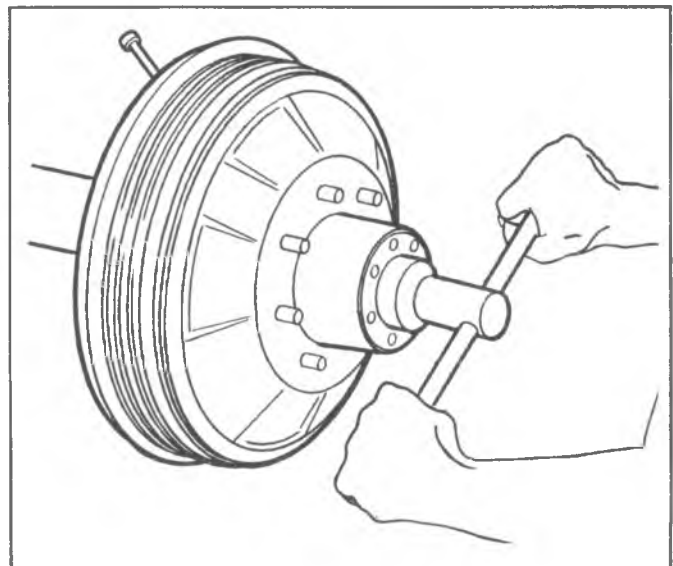

Fig. 4B2-3--Removing Lock Nut-Typical

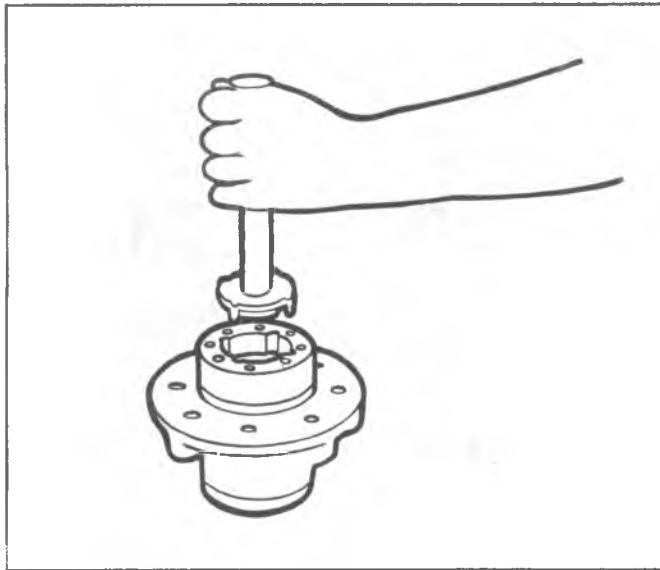

Fig. 4B2-4--Removing Outer Bearing and Cup

3. Examine axle shaft flange studs, wheel studs, hub splines, hub bore, and tapped holes for evidence of damage. Clean up threads or replace parts where required.
4. Examine oil seal sleeve for evidence of wear or roughness, check axle housing oil deflector and brake drum oil deflector for evidence of damage. Replace parts where required.
5. Examine brake drum for excessive scoring and other damage. To replace brake drum refer to "Brake Drum Replacement."
6. Immerse bearing cone and roller assemblies in cleaning solvent. Clean with stiff brush to remove old lubricant. Blow bearings dry with compressed air, directing air stream across bearing. Do not spin bearings while blowing them dry.
7. Thoroughly remove all lubricant from axle housing tube and from inside the hub, wipe dry. Make sure all particles of gasket are removed from outer end of hub, axle shaft, and hub cap.
8. Scrape old sealing compound out of oil seal bore in the hub.

#### Bearing/Cup-Installation

1. Place **outer** bearing into hub.
2. Install cup of outer bearing into hub by using Handle J-8092 and J-8608, **installed upside-down**. Be sure J-8608 is upside down on driver handle, so that chamfer does **not** contact bearing cup.
3. Drive cup **beyond** the snap ring groove.
4. Using a pair of pliers, install snap ring into its groove.
5. Drive cup back **against** snap ring by using J-24426, as shown in figure 4B2-4.
6. To install **inner** bearing cup, use J-24427 on Handle J-8092. Drive cup into place until it seats against shoulder of hub bore.
7. Install new oil seal with J-24428.

### Drum-Non-Demountable-Type-Fig. 4B2-2

#### Replacement

Construction of the nondemountable-type hub and drum assembly is such that replacement cannot be accomplished with the hub assembly installed on the vehicle.

1. Separate the drum and hub by removing the drum-to-hub retaining bolts, hub stud nuts, or by pressing out the wheel studs, as applicable.
2. Position brake drum to hub assembly, making certain that all drain holes are in alignment.
3. Apply a light, even coating of sealing compound to the hub oil deflector contact surface, and position deflector to drum.
4. Install drum-to-hub retaining bolts, hub stud nuts, or press wheel studs into drum, as applicable.

#### Wheel Bolt

##### Replacement

Wheel bolts are serrated and may also be swaged in place; however, replacement procedure remains the same for both types of installation.

Press bolts out of hub flange and press new bolts into place, making sure they are a tight fit. If all bolts are removed, be sure that hub oil deflector is in position under bolt heads. See figure 4B2-5.

#### Installation of Hub and Drum Assembly

1. Using a high melting point EP bearing lubricant, liberally pack bearings and apply a light coat on I.D. of hub bearing contact surface and O.D. of axle housing tube.
2. Make sure inner bearing, oil seal, axle housing oil deflector, and inner bearing race and oil seal are properly positioned.
3. Install hub and drum assembly on axle housing, exercising care so as not to damage oil seal or dislocate other internal components.
4. Install thrust washer so that tang on I.D. of washer is in keyway on axle housing.

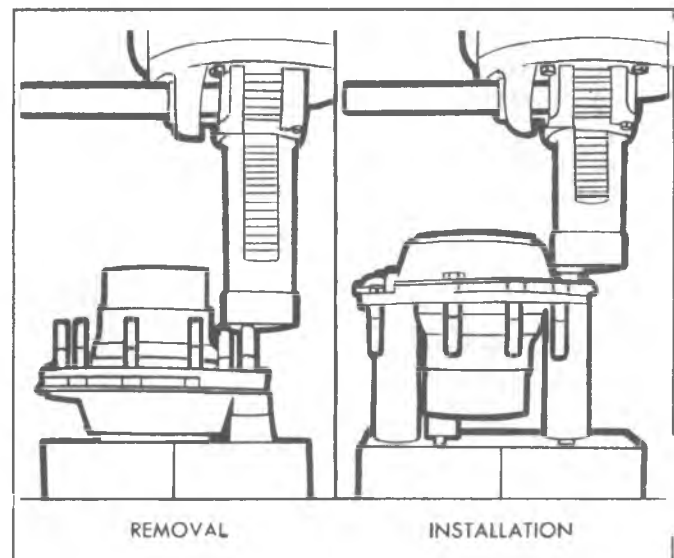

Fig. 4B2-5--Wheel Bolt Replacement

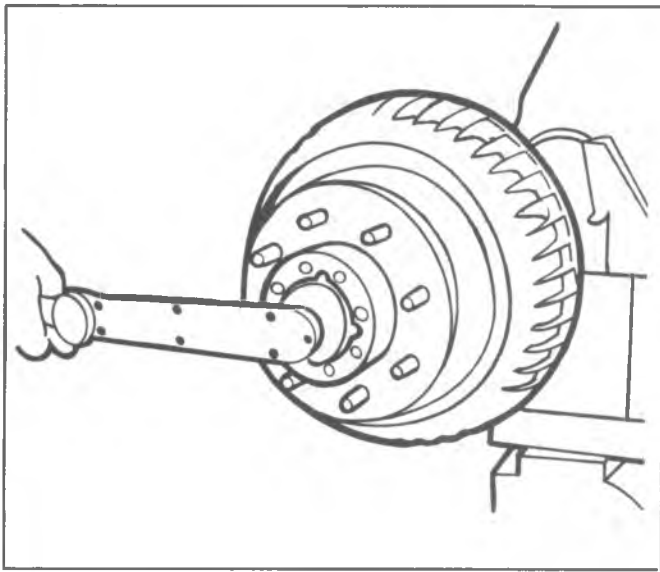

Fig. 4B2-6--Tightening Adjusting Nut-Typical

5. Install adjusting nut and complete the installation as directed under "Bearing Adjustment."

### BEARING ADJUSTMENT

Before checking bearing adjustment, make sure brakes are fully released and do not drag.

Check bearing play by grasping tire at top and pulling back and forth, or by using a pry bar under tire. If bearings are properly adjusted, movement of brake drum in relation to brake flange plate will be barely noticeable and wheel will turn freely. If movement is excessive, adjust bearing as follows:

1. Remove axle shaft and raise vehicle until wheel is free to rotate.
2. Keyways and threads on tube and nut must be clean and free from chips, burrs and shavings.
3. Disengage tang of retainer and remove retainer from axle housing tube.
4. Torque adjusting nut to 70 N·m (50 ft. lbs.), at the same time rotating the hub assembly and making sure bearing cones are seated and in contact with the spindle shoulder (figure 4B2-6).

Proper wheel bearing adjustment can be made using tool J-2222-02 with some modification or tool J-2222-L figure 4B2-7.

5. Back off nut until loose.

### DIFFERENTIAL CASE

If equipped with a locking differential, also refer to Section 4B6.

#### Removal

1. Mount axle assembly in a bench vise or holding fixture.
2. Remove cover bolts and cover, as seen in figure 4B2-8, and allow lubricant to drain into pan.
3. Remove axle shafts.

Before proceeding with following steps, it is advisable

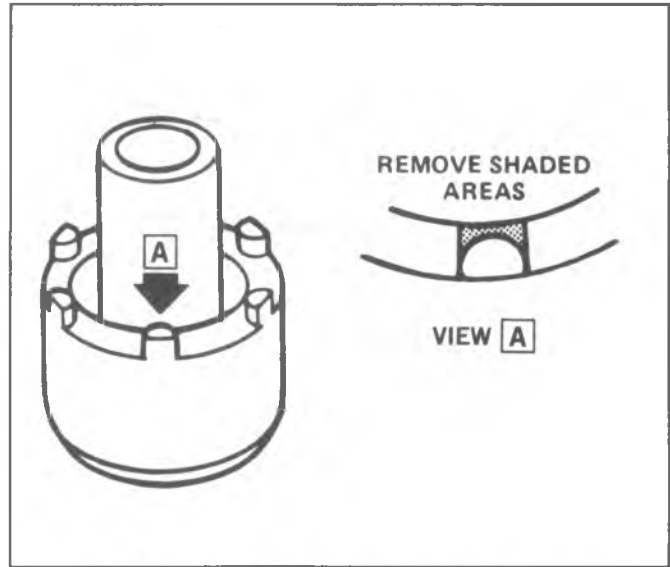

Fig. 4B2-7--Wheel Bearing Adjusting Tool

6. If adjusting nut slot in alignment with keyway in axle spindle, insert square key into slot. If adjusting nut slot is not aligned, back off nut a slight amount and insert square key into slot. Do not back off nut more than one slot to align key.
7. Assemble snap ring at end of spindle to retain key in position.

### PINION OIL SEAL / COMPANION FLANGE

#### Replacement

The pinion oil seal may be replaced with the carrier assembly installed in the vehicle.

1. Disconnect propeller shaft.
2. Scribe a line down the pinion stem, pinion nut and companion flange.
3. Use J-8614-11 to remove the pinion nut and the companion flange.
4. Pry the oil seal from the bore, using care not to damage the machined surfaces. Thoroughly clean all foreign material from contact area.
5. Lubricate the cavity between the seal lips with a high melting point bearing lubricant.
6. Install a new pinion oil seal into the bore, using J-24434.
7. Reinstall the companion flange, pinion nut and propeller shaft.

**NOTICE:** See NOTICE on page 1 of this section, regarding the above fasteners.

## UNIT REPAIR

to check the existing ring gear to pinion backlash as described in Step 9 of 'Differential Case - Installation.' This will indicate gear or bearing wear or an error in backlash or pinion depth setting which will help in determining cause of axle noise. Backlash should be recorded so that if same gears are reused, then may be reinstalled at original lash to avoid changing gear tooth contact.

4. Remove adjusting nut lock retainers from bearing caps.
5. Mark bearing caps for reinstallation in the same position, and remove caps.

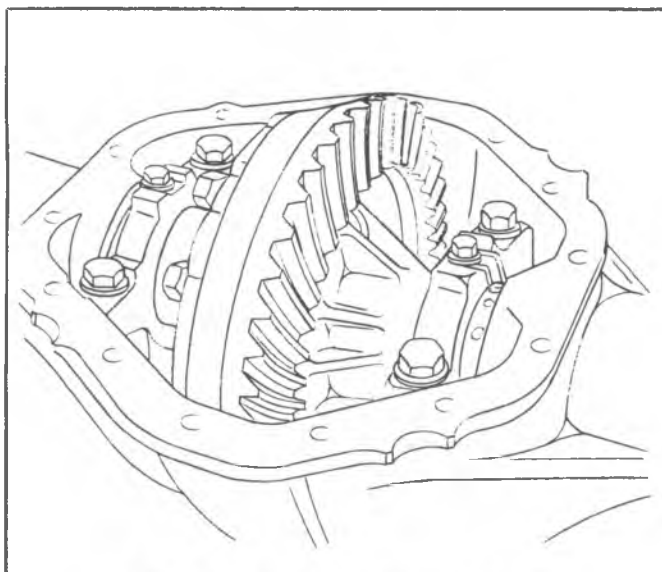

Fig. 4B2-8--Cover Removed from Carrier

6. Loosen side bearing adjusting nuts, using J-24429 as shown in figure 4B2-9.
7. Remove differential from carrier.

**Side Bearing Replacement**

1. Install bearing puller J-8107 onto one side bearing, with puller screw centered on pilot plug as shown in figure 4B2-10. Be sure to install puller fingers into notches of case, in order to pull on inner race only.
2. Tighten puller screw, while rotating bearing to insure that bearing cage is not being distorted.
3. Remove the other bearing in the same manner.
4. Inspect bearings and hub for nicks, burrs or evidence of abnormal wear.
5. To install bearings, place bearing onto hub, and use driver handle J-8092 and bearing installer J-24430 to drive bearing onto hub until it seats against the shoulder.

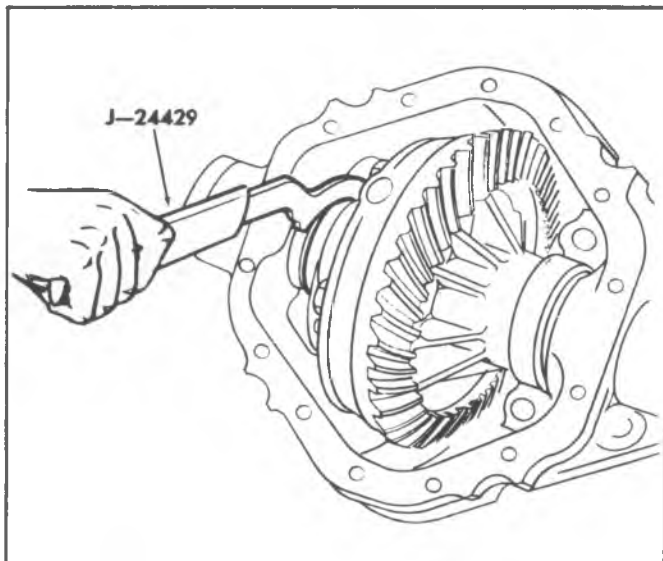

Fig. 4B2-9--Loosening Adjusting Nuts

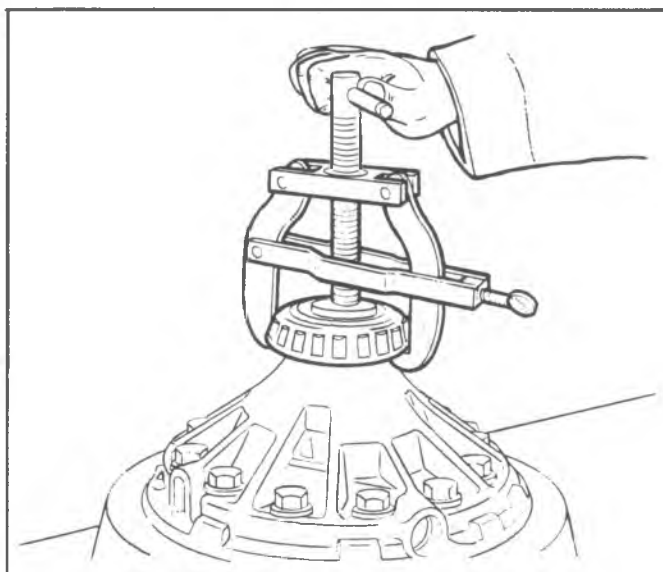

Fig. 4B2-10--Differential Bearing Removal

6. When installing the second bearing, support case on pilot plug as shown in figure 4B2-11 to prevent damage to first bearing installed.

**Ring Gear Replacement**

1. Remove the ring gear bolts and lock washers, and use a soft faced hammer to tap the ring gear from the case.
2. Place new ring gear into position on case and install lock washers and bolts.

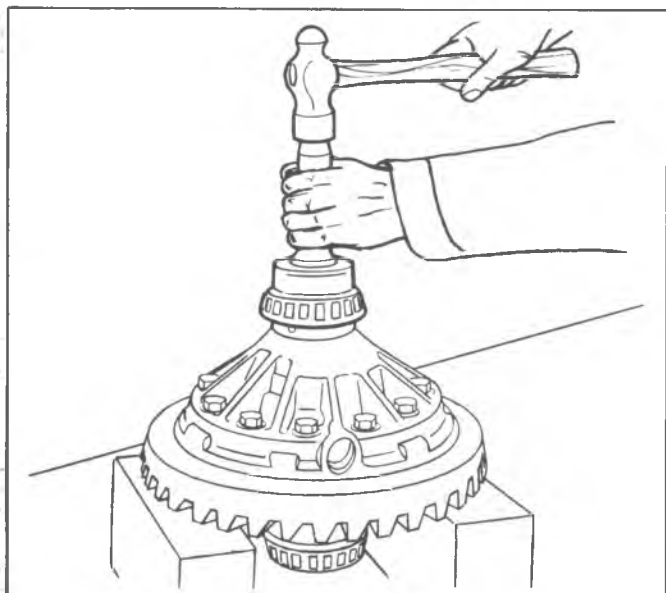

Fig. 4B2-11--Differential Bearing Installation

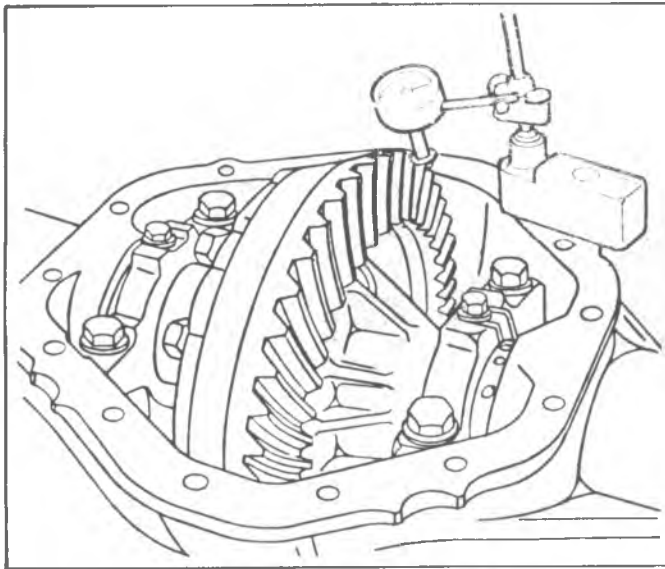

Fig. 4B2-12--Measuring Backlash

3. Torque bolts alternately to specifications.

#### Disassembly of Case

1. Mark the case and cover halves with a scribe line for reassembly in the same position.
2. With ring gear removed, separate case and cover.
3. Remove the internal parts and keep separated so they may be installed in the same relative positions.

#### Inspection

1. Inspect the differential gears, pinions, thrust washers, spider and all mating surfaces for evidence of abnormal wear.
2. Clean all parts thoroughly in suitable solvent.
3. Replace parts as necessary.

#### Reassembly of Differential

1. Lubricate internal parts with hypoid gear lubricant.
2. Place differential pinions and thrust washers onto spider.
3. Assemble differential gears and washers to case and cover.
4. Assemble differential case and cover making sure scribe marks align.
5. Install ring gear and attaching bolts and lockwashers and torque alternately to specifications.
6. The differential may be installed into the carrier at this point, or may be installed after servicing the drive pinion.

#### Installation and Adjustment

1. Place bearing cups over side bearings and lift the differential assembly into the carrier. Install bearing caps, making sure marked caps are installed in original positions. Secure the cap bolts snugly.
2. Loosen the right side adjusting nut and tighten the left side nut, using J-24429 as shown in figure 4B2-9, until the ring gear contacts the drive pinion. Do not force the gears into contact so as to bind them. At this point, zero lash is obtained.

3. Back off the left adjusting nut approximately two slots. Install locking fingers into holes and fasten fingers to bearing cap.
4. Tighten right adjusting nut firmly to force the case into solid contact with the left adjusting nut.
5. Loosen right adjusting nut until it is free from its bearing, then retighten until it contacts the bearing.
6. Tighten right adjusting nut approximately two slots if used bearings are being installed, or three slots if new bearings are being installed.
7. Install locking retainer into holes and attach fingers to bearing cap.
8. Torque bearing cap bolts to specifications. At this point the differential bearings are properly preloaded. If any additional adjustments are required in the following procedures, make sure that the preload remains as established. If one adjusting nut is loosened, the other nut must be tightened **an equal amount** to maintain this preload.
9. Mount a dial indicator on the housing and measure the backlash between the ring gear and pinion. Backlash should be from .003" to .012" with .005" to .008" preferred. Refer to figure 4B2-12.

If backlash is more than .012", loosen the right adjusting nut one slot and tighten left adjusting nut one slot. If backlash is less than .003", loosen the left adjusting nut one slot and tighten the right adjusting nut one slot.

#### DRIVE PINION ASSEMBLY

##### Removal

1. Remove differential as previously outlined.
2. Check pinion bearing preload as described under "Drive Pinion - Reassembly". Record the result. If there is no preload reading, check for looseness of pinion assembly by shaking the companion flange. Looseness indicates the need for bearing replacement.
3. Remove the pinion bearing retainer bolts from the housing as shown in figure 4B2-13.
4. Remove the pinion and bearing retainer assembly. It may be necessary to rap on the pilot end of the pinion to assist the assembly from the carrier.
5. Record the thickness of the shims removed from between the bearing retainer flange and the carrier housing.

##### Disassembly

1. Clamp the pinion assembly in vise.
2. Install Holder J-8614-11 on flange by using two bolts with flat washers, as shown in figure 4B2-14. Position J-8614-11 on flange so that the four notches are toward the flange.
3. Use a suitable sized socket to remove the pinion nut and washer. Discard the pinion nut and use a new one upon reassembly.
4. Thread end of J-8614-3 into small O.D. end of J-8614-2. Then with J-8614-11 installed as a step 2, insert J-8614-2 into J-8614-11 and turn it 1/8 of a turn to locked position. Remove flange by turning J-8614-3 while holding J-8614-11 as shown in figure 4B2-15.
5. Support the bearing retainer as shown in figure

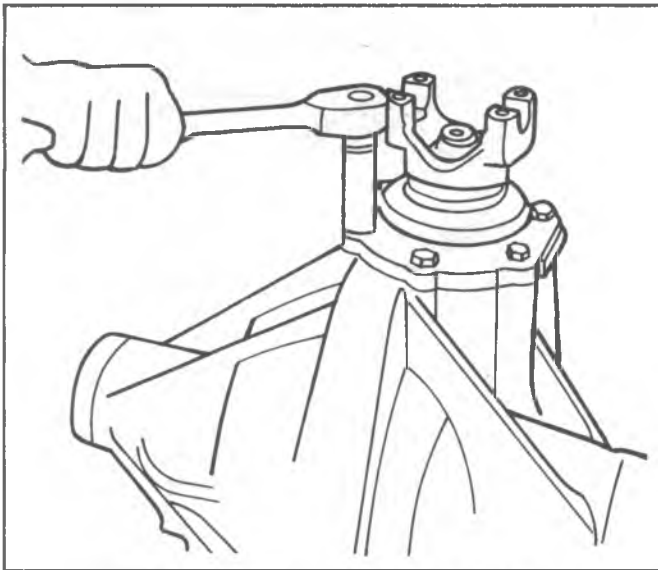

Fig. 4B2-13--Removing Retainer Bolts

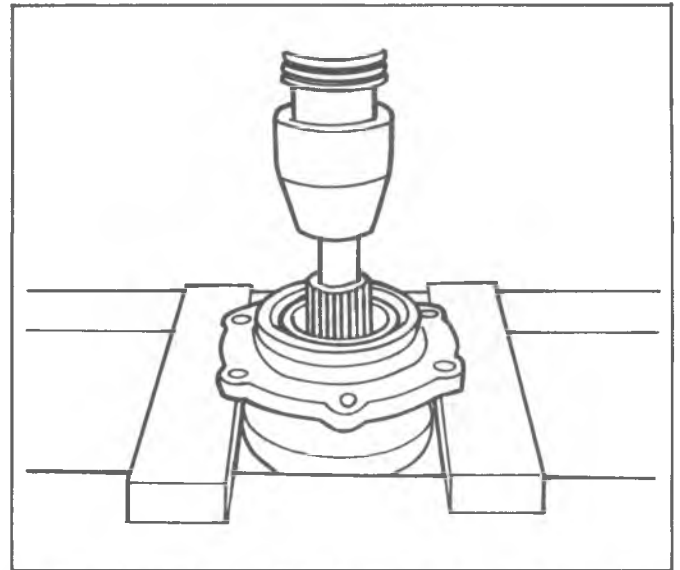

Fig. 4B2-16--Pressing Drive Pinion from Bearing Retainer

4B2-16 and press out the drive pinion. Do not allow drive pinion to fall onto the floor.

6. Separate the pinion flange, the oil seal, the front bearing and the bearing retainer. The oil seal may have to be driven from the bearing reatiner if it is being replaced.
7. Drive the pinion front and rear bearing cups from the bearing retainer, using a drift.
8. To remove the rear bearing, use J-22912 as shown in figure 4B2-17.
9. Drive the pinion straddle bearing from the carrier housing, using a drift as shown in figure 4B2-18.

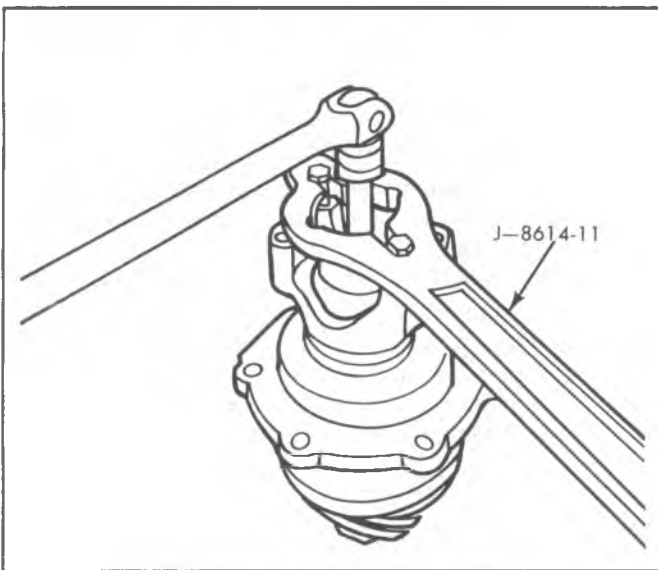

Fig. 4B2-14--Removing Pinion Nut

**Inspection**

1. Clean all parts in a suitable solvent and dry with air.
2. Inspect the drive pinion for chipped, cracked or excessively worn teeth and inspect the splines for wear.
3. Inspect the bearings for worn or pitted rollers or races. Inspect the pinion flange splines for wear.

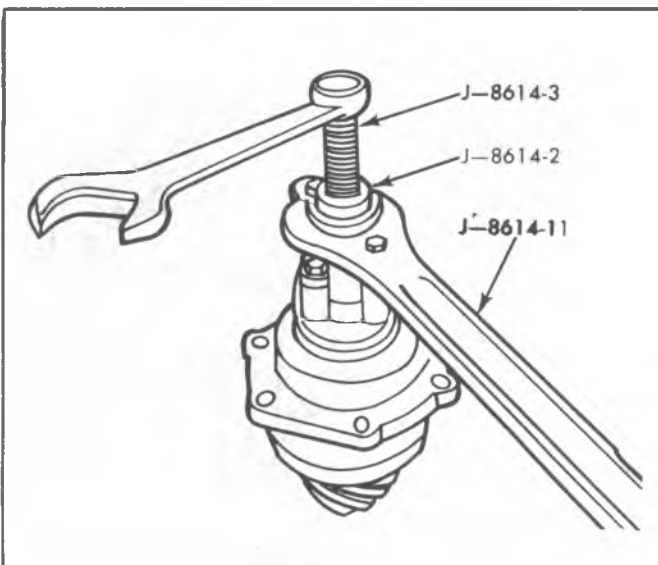

Fig. 4B2-15--Removing Flange

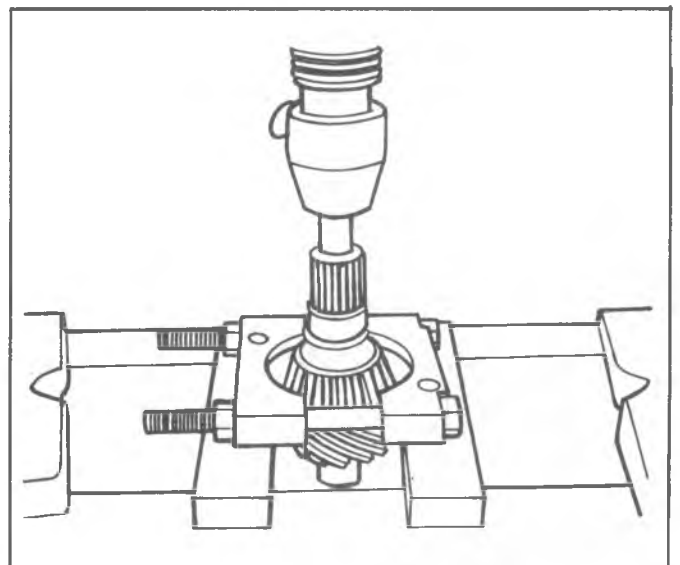

Fig. 4B2-17--Removing Pinion Rear Bearing



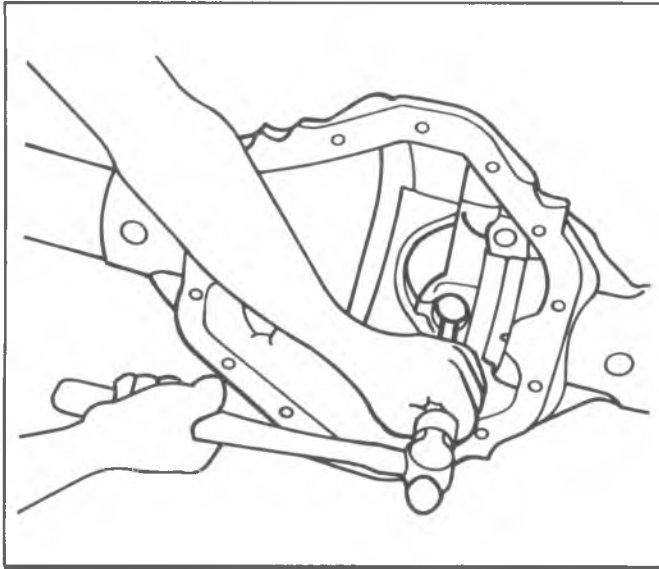

Fig. 4B2-18--Removing Straddle Bearing

4. Inspect the bearing retainer for cracks, imperfections, corrosion, pits and grooves.
5. Replace parts as required.

#### Reassembly

1. Lubricate all parts with hypoid lubricant.
2. Press pinion rear bearing onto drive pinion as shown in figure 4B2-19, using J-24433.
3. Install the front end rear pinion bearing cups into the bearing retainer, using driver handle J-8092 on J-8608 for the front cup, and on J-24432 for the rear cup.
4. Install the pinion straddle bearing into the carrier housing, using driver handle J-8092 and installer J-23322, as shown in figure 4B2-20.
5. Place bearing retainer, with cups in position, onto the drive pinion. Install a new collapsible spacer into position.
6. Press front bearing onto drive pinion.
7. Lubricate the oil seal lips with a lithium-base

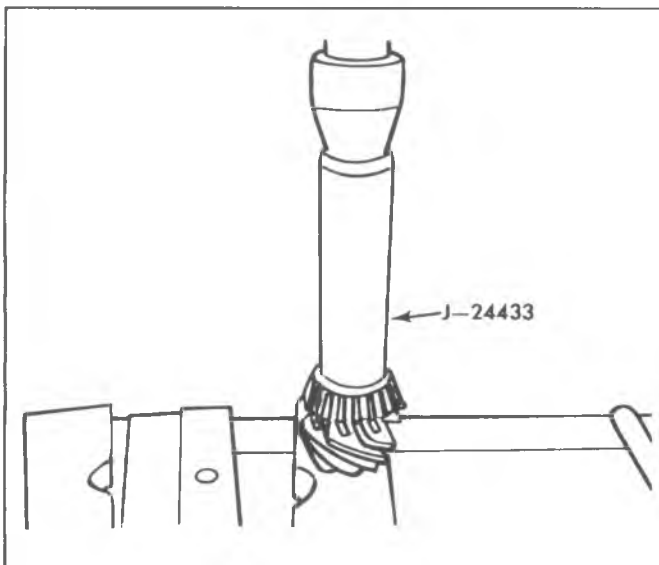

Fig. 4B2-19--Installing Pinion Rear Bearing

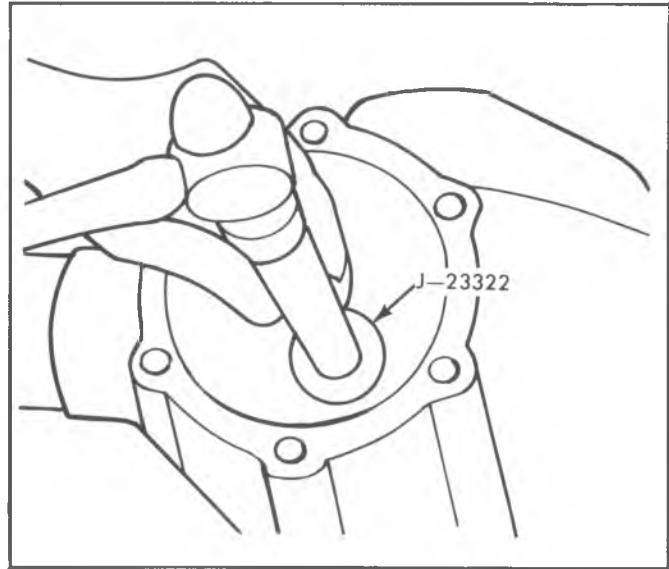

Fig. 4B2-20--Installing Straddle Bearing

8. Install pinion flange and oil deflector onto the splines, then install lock washer and new pinion nut.
  9. Clamp the pinion flange into a vise. Install J-8614-11 as in figure 4B2-14. Tighten the nut to achieve proper bearing preload.
    - a. Proper preload is attained when rotational torque required to rotate the pinion is 25-35 in. lbs. for new bearings, or 5-15 in. lbs. for used bearings.
    - b. Tighten pinion nut to approximately 350 ft. lbs., then take a torque reading as shown in figure 4B2-21 using J-5853.
    - c. Continue tightening pinion nut in small increments until proper preload is attained.
- NOTICE:** Over-tightening of pinion nut may collapse spacer too much, requiring its replacement.

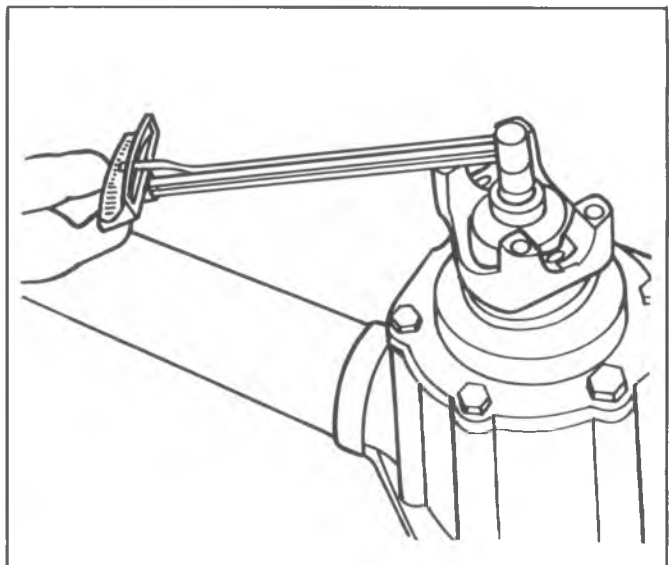

Fig. 4B2-21--Measuring Rotating Torque



|   |    | CODE NUMBER ON ORIGINAL PINION |               |               |               |             |
|---|----|--------------------------------|---------------|---------------|---------------|-------------|
|   |    | +2                             | +1            | 0             | -1            | -2          |
| CODE<br>NUMBER<br>ON<br>SERVICE<br>PINION | +2 | -                              | ADD .001      | ADD .002      | ADD .003      | ADD .004    |
|   | +1 | SUBT.<br>.001                  | -             | ADD<br>.001   | ADD<br>.002   | ADD<br>.003 |
|   | 0  | SUBT.<br>.002                  | SUBT.<br>.001 | -             | ADD<br>.001   | ADD<br>.002 |
|   | -1 | SUBT.<br>.003                  | SUBT.<br>.002 | SUBT.<br>.001 | -             | ADD<br>.001 |
|   | -2 | SUBT.<br>.004                  | SUBT.<br>.003 | SUBT.<br>.002 | SUBT.<br>.001 | -           |

Fig. 4B2-22--Pinion Depth Codes

### Installation and Adjustment

- Examine the head of the drive pinion for a pinion depth code number.
- Compare the depth code number with the number on the original pinion. Use the following chart to select the proper shim for preliminary setting of pinion depth.
- Refer to the thickness of the shim recorded earlier in Pinion Removal procedures. Increase or decrease the shim dimension as indicated by the chart in figure 4B2-22.
  - For example, if original shim measured .014 inch, original code was -1 and new code is +2, the correct shim would be .014 inch plus .003 = .017 inch.
  - If original shim was .012 inch, original code +2, and new code is -2, the correct shim would be .012 minus .004 = .008 inch.
- Place the pinion shim as determined in step 3 onto the carrier housing, making sure the bolt holes align with those of carrier, and that the mating surfaces are clean and free from foreign material.
- Place the pinion retainer assembly into position, and align bolt holes to carrier. Install retaining bolts and tighten in a crosswise manner. Torque to specifications.
- Following drive pinion service, a Gear Tooth Contact Pattern Check must be made.

### OPERATIONAL CHECK AND ADJUSTMENTS

Four adjustments are essential for proper operation of the differential and its related parts. These adjustments are a) Pinion Bearing Preload, b) Side Bearing Preload, c) Pinion Depth and d) Ring Gear-to-Pinion Backlash.

Refer to Section 4B for description of how to perform these checks and adjustments.



## SECTION 4B3

# DANA 10-1/2" RING GEAR AXLE

The following notice applies to one or more steps in the assembly procedure of components in this portion of the manual as indicated at appropriate locations by the terminology "See Notice on Page 1 of this Section".

**NOTICE:** This fastener is an important attaching part in that it could affect the performance of vital components and systems, and/or could result in major repair expense. It must be replaced with one of the same part number or with an equivalent part if replacement

becomes necessary. Do not use a replacement part of lesser quality or substitute design. Torque values must be used as specified during reassembly to assure proper retention of this part.

### CONTENTS

|  |       |   |       |
|--|-------|---|-------|
| On-Vehicle Service .....                       | 4B3-1 | Shim Requirements-Gaging Procedures.....            | 4B3-4 |
| Unit Repair .....                              | 4B3-1 | Drive Pinion-Assembly and Installation .....        | 4B3-5 |
| Differential Case-Removal and Disassembly..... | 4B3-1 | Differential Case-Installation and Adjustments..... | 4B3-6 |
| Drive Pinion-Removal and Disassembly.....      | 4B3-3 | Operational Checks and Adjustments .....            | 4B3-6 |
| Differential Case-Reassembly .....             | 4B3-4 |   |       |

## ON-VEHICLE SERVICE

Procedures for service to axle assembly, axle shafts, hub and drum components and bearing adjustments are identical to those described for "Chevrolet 10-1/2" Ring Gear Axle".

Drive pinion oil seal replacement requires different special tools for the Dana axles. Follow the same procedure listed for "Chevrolet 10-1/2" Ring Gear Axle"; use J-24384 for seal replacement on Dana 10-1/2" Ring Gear Axles.

## UNIT REPAIR

This Dana Spicer axle is similar in design to other Salisbury type axles with the following exceptions:

- In order to remove the differential case, the carrier must be spread.
- The drive pinion assembly incorporates an inner and outer bearing shim. The inner shim is used to maintain proper pinion depth. The outer shim is used to maintain proper preload on the pinion bearing.

### DIFFERENTIAL CASE

#### Removal

1. Place vehicle on hoist with rear axle hanging free.
2. Remove wheel and tire assemblies.
3. The axle shafts are full-floating type with flanged outer end of shaft attached to wheel hub by studs and nuts. Wheel is supported by tapered roller bearings at outer end of axle housing.
  - a. Remove axle shaft to hub attaching nuts.
  - b. Rap on axle shaft to loosen shaft from hub and remove shafts.
4. Remove plug in carrier and drain lubricant.
5. Remove cap screws and lock washers attaching cover to carrier. Remove cover and gasket.
6. Mark one side of carrier and matching cap for reassembly in the same position. Remove bearing caps.

7. Using spreader tool J-24385, and a dial indicator as shown in figure 4B3-2, spread carrier a maximum of .015 inch.

**NOTICE:** Do not exceed this dimension, as carrier may be permanently damaged.

8. Remove the dial indicator and use a prybar to remove the differential case from the carrier. Record the dimensions and location of the side bearing shims. Remove the spreader tool.

#### Disassembly

1. Remove differential side bearings by using bearing puller J-29721.  
Use care not to damage bearings with tool J-29721.
2. Remove the ring gear bolts and the ring gear. Tap the ring gear with a soft-faced hammer to free it from the case.
3. Scribe both case halves for reassembly in same position.
4. Remove bolts holding case halves together, as shown in figure 4B3-3.
5. Tap lightly on top half of case to free it from the bottom half. Remove top half of case.
6. Lift out all internal parts.

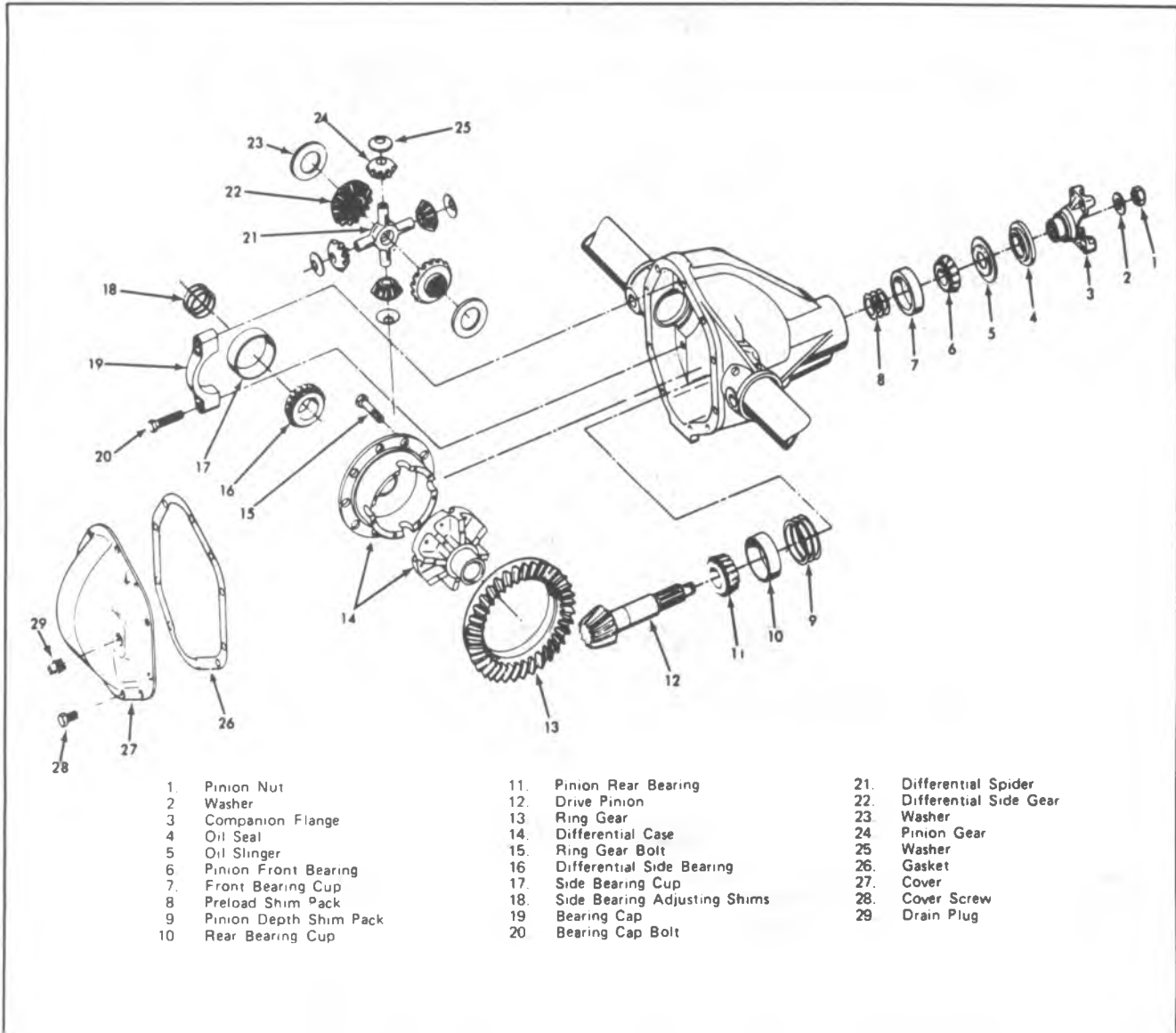

Fig. 4B3-1--Dana Differential with 10-1/2" Ring Rear - Exploded View L

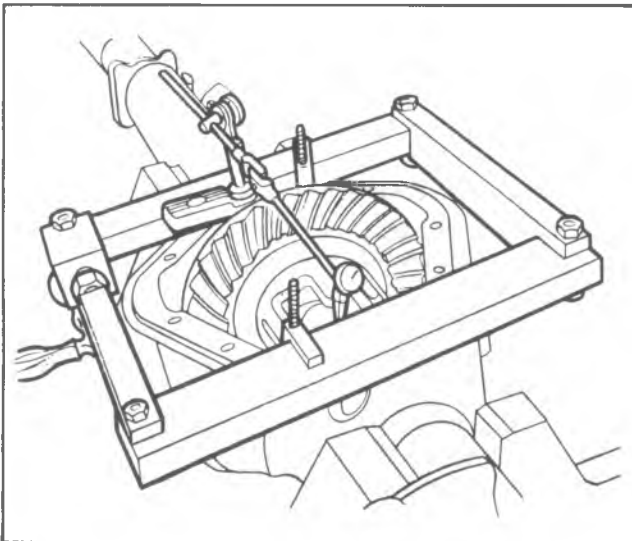

Fig. 4B3-2--Spreading the Carrier

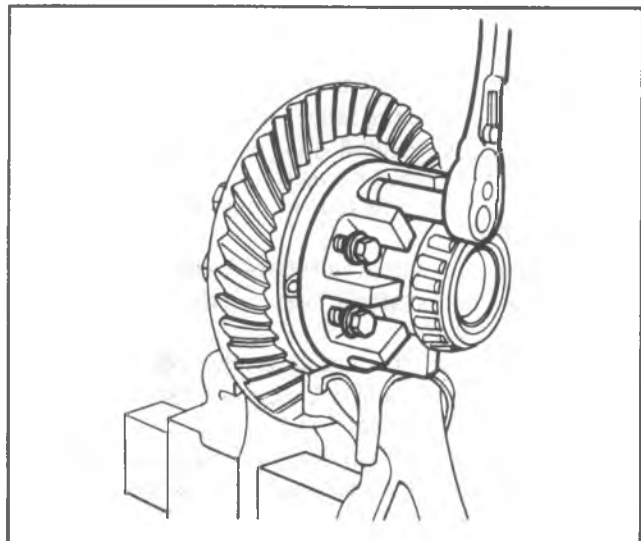

Fig. 4B3-3--Separating Case Halves

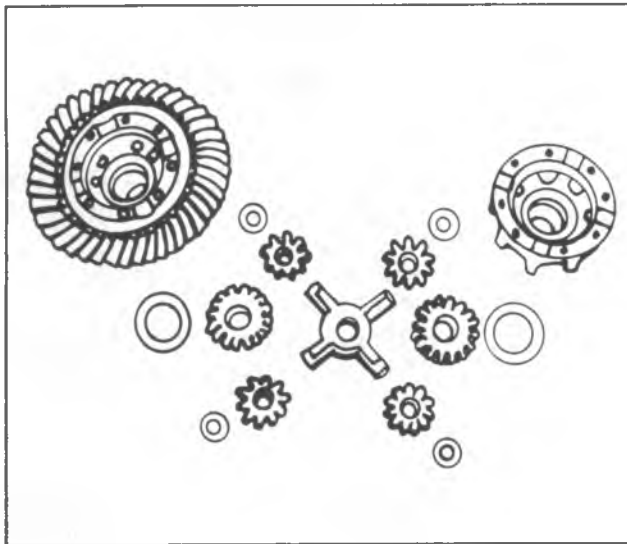

Fig. 4B3-4--Internal Parts Inspection

**Inspection (Figure 4B3-4)**

1. Clean all gears and bearings in solvent. Inspect cups, races and rollers for scoring, chipping or evidence of excessive wear.
2. Inspect ring gear teeth and machined surfaces. Examine fit of internal gears.
3. Inspect pinion cross-shaft.
4. Replace parts as required.

**DRIVE PINION****Removal and Disassembly**

1. Remove differential as previously outlined.
2. Check pinion bearing preload as described under "Drive Pinion - Installation and Adjustment." If there is no preload reading, check for looseness of pinion assembly by shaking the companion flange. Looseness indicates the need for bearing replacement.
3. Install Holder J-8614-11 on flange by using two bolts with flat washers, as shown in figure 4B3-5.

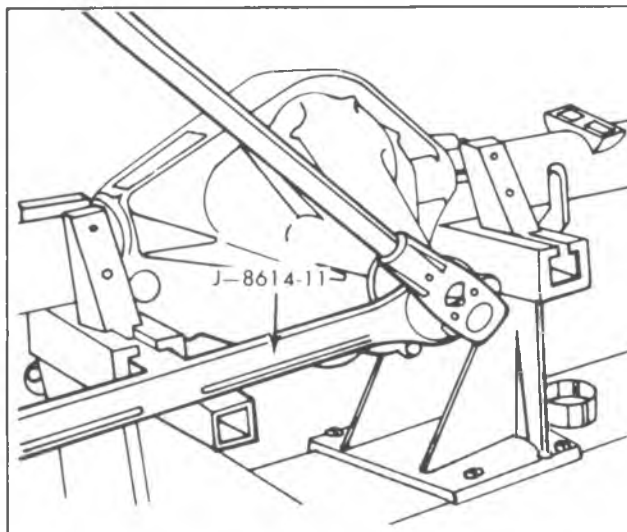

Fig. 4B3-5--Removing Pinion Nut

Position J-8614-11 on flange so that the four notches are toward the flange.

4. Remove pinion nut and washer. Discard pinion nut and use a new one upon reassembly.
5. Thread end of J-8614-3 into small O.D. end of J-8614-2. Then with J-8614-11 installed as in step 3, insert J-8614-2 into J-8614-11 and turn it 1/8 of a turn to locked position. Remove flange by turning J-8614-2 while holding J-8614-22 as shown in figure 4B3-6.
6. Remove drive pinion from carrier. It may be necessary to tap on the pinion with a soft faced hammer.
7. With a long drift tap on inner race of outer pinion bearing to remove pinion oil seal, slinger, gasket, outer pinion cone and roller and shim pack. Tag shim pack for reassembly.
8. Should inspection indicate necessity, pinion bearing cups can be removed from carrier using a long drift and hammer. Remove shims and oil slinger which are located behind the inner bearing cup. Tag shims for reassembly.
9. Remove rear pinion bearing using J-22912, and an arbor press.

**Inspection**

1. Clean all gears and bearings in cleaning solvent and inspect all bearing cups, races and rollers for scoring, chipping or evidence of excessive wear. On pinion bearing rollers, inspect large end of rollers for wear. This is where wear is most evident on tapered roller bearings.
2. Inspect pinion splines and flange splines for evidence of excessive wear.
3. Inspect ring gear and pinion teeth for possible scoring, cracking or chipping.
4. Inspect differential case for cracks or scores or side gears, thrust washers, and pinion thrust faces.
5. Check fit of differential side gears in case.
6. Check fit of side gears and axle shaft splines.
7. Inspect differential pinion shaft and spacer for scoring or evidence of excessive wear.

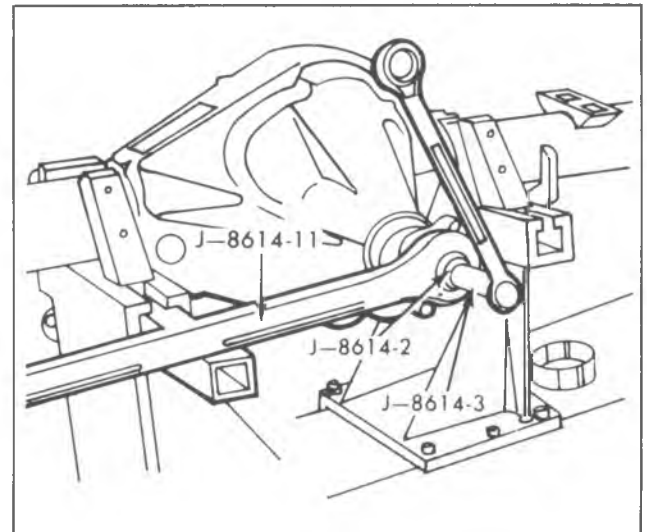

Fig. 4B3-6--Removing Companion Flange

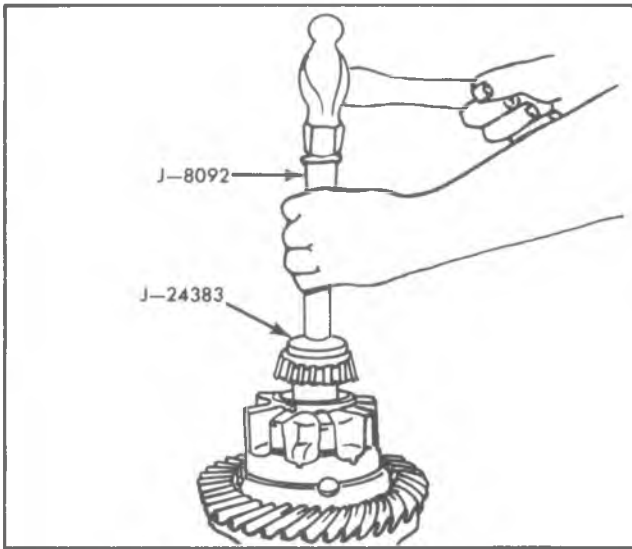

Fig. 4B3-7--Installing Side Bearing

**DIFFERENTIAL CASE**

**Reassembly**

1. Assemble new washers to side gears. Apply a small amount of hypoid lubricant on the side gear hubs.
2. Assemble pinion gears and new washers onto cross shaft.
3. Place side gears, pinion gears, cross shaft and washers into flanged half of case.
4. Assemble top half of case to bottom half, making sure scribe marks are aligned.
5. Assemble body bolts finger tight. Then tighten bolts alternately to specifications.
6. Install ring gear to differential case.
7. Install ring gear-to-case bolts finger tight, then tighten alternately to specifications.
8. Place side bearing into position and install, using tools J-8092 and bearing installer J-24383 as shown in figure 4B3-7.

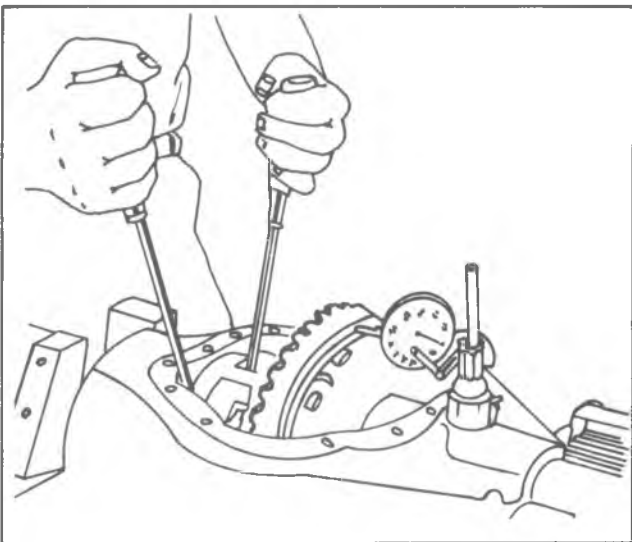

Fig. 4B3-8 -Screwdrivers Against Case L

9. Install bearing on opposite side in the same manner. Be sure to support differential case on pilot plug J-8107-3.

**SHIM REQUIREMENTS - GAGING PROCEDURES**

**Side Bearing Shims**

1. With the pinion removed from the carrier, place the bearing cups over the side bearings, and install the differential case into the carrier.
2. Place the shim which was originally installed on the ring gear side into its original position.
3. Install the bearing caps lightly in their marked positions. Tighten the caps just enough to keep the bearings in place.
4. Mount a dial indicator on the carrier with the tip of the indicator on the back face of the ring gear.
5. Position two screwdrivers between the bearing shim and carrier on the ring gear side of the case. Pull on the screwdrivers and force the differential case as far as possible away from the dial indicator.
6. With force still applied, set the indicator dial to "zero", being sure the probe is still in contact with the ring gear.
7. Reposition the screwdrivers to the opposite side of the differential case as shown in figure 4B3-8.
8. Pull on the screwdrivers and force the differential case back toward the dial indicator. Repeat several times until the same indicator reading is obtained.
9. To the dial indicator reading, add the thickness of the shim. Record the result, as this figure will be used during determination of side bearing shim requirements.

| Old Pinion Marking | New Pinion Marking |         |         |         |         |         |         |         |         |  |
|--------------------|--------------------|---------|---------|---------|---------|---------|---------|---------|---------|--|
|                    | - 4                | - 3     | - 2     | - 1     | 0       | + 1     | + 2     | + 3     | + 4     |  |
| + 4                | + 0.008            | + 0.007 | + 0.006 | + 0.005 | + 0.004 | + 0.003 | + 0.002 | + 0.001 | 0       |  |
| + 3                | + 0.007            | + 0.006 | + 0.005 | + 0.004 | + 0.003 | + 0.002 | + 0.001 | 0       | - 0.001 |  |
| + 2                | + 0.006            | + 0.005 | + 0.004 | + 0.003 | + 0.002 | + 0.001 | 0       | - 0.001 | - 0.002 |  |
| + 1                | + 0.005            | + 0.004 | + 0.003 | + 0.002 | + 0.001 | 0       | - 0.001 | - 0.002 | - 0.003 |  |
| 0                  | + 0.004            | + 0.003 | + 0.002 | + 0.001 | 0       | - 0.001 | - 0.002 | - 0.003 | - 0.004 |  |
| - 1                | + 0.003            | + 0.002 | + 0.001 | 0       | - 0.001 | - 0.002 | - 0.003 | - 0.004 | - 0.005 |  |
| - 2                | + 0.002            | + 0.001 | 0       | - 0.001 | - 0.002 | - 0.003 | - 0.004 | - 0.005 | - 0.006 |  |
| - 3                | + 0.001            | 0       | - 0.001 | - 0.002 | - 0.003 | - 0.004 | - 0.005 | - 0.006 | - 0.007 |  |
| - 4                | 0                  | - 0.001 | - 0.002 | - 0.003 | - 0.004 | - 0.005 | - 0.006 | - 0.007 | - 0.008 |  |

Fig. 4B3-9--Dana Pinion Code Chart

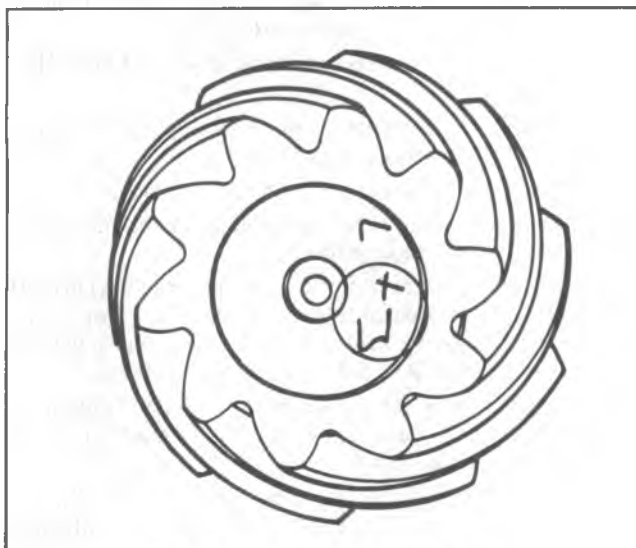

Fig. 4B3-10--Pinion Code Location

### Pinion Shims

Ring gears and pinions are supplied in matched sets only. Matching numbers on both pinion and ring gear are etched for verification. If a new gear set is being used, verify the numbers of each pinion and ring gear before proceeding with assembly.

On the rear face of each pinion there is etched a plus (+) number, a minus (-) number, or a zero (0) number, which indicates the best running position for each particular gear set. This dimension is controlled by the shimming behind the inner bearing cup. Whenever baffles or oil slingers are used, they become a part of the adjusting shim pack.

For example: if a pinion is etched +3, this pinion would require .003" less shims than a pinion etched "0". This means by removing shims, the mounting distance of the pinion is increased by .003" which is just what a + etching indicates. Or if a pinion is etched -3, we would want to add .003" more shims than would be required if the pinions were etched "0". By adding .003" shims, the mounting distance of the pinion was decreased .003" which is just what a -3 etching indicated. Refer to figure 4B3-10.

If the old ring and pinion set is to be reused, measure the old shim pack and build a new shim pack to this same dimension. If baffle is in the axle assembly, it is considered as part of the shim pack.

To change the pinion adjustment, shims are available in thicknesses of .003", .005" and .010".

If baffle or slinger is bent or mutilated, it should be replaced.

Measure each shim separately with a micrometer and add together to get total shim pack thickness from original build up.

If a new gear set is being used, notice the plus or minus etching on both the old and new pinion, and adjust the thickness of the old shim pack to compensate for the difference of these two figures.

For example: If the old pinion reads (+2) and the pinion is (-2), add .004" shims to the original shim pack.

## DRIVE PINION

### Assembly and Installation

1. Determine the correct pinion depth shim by using the chart in figure 4B3-9.
2. Install the pinion depth shim in rear cup bore.
3. Install rear bearing cup by using driver handle J-8092 and installer J-24381.
4. To the outer shim pack (for setting preload) add or remove an equal amount as was added or removed from the inner shim pack.
5. Install outer cup in carrier bore, using installer J-7818 with Drive Handle J-8092.
6. Press rear pinion bearing onto pinion shaft, using installer J-24433.
7. Install drive pinion and bearing into the differential carrier.
8. Install preload shims and front pinion bearing. Do not install oil seal at this time.
9. Install flange and holding bar J-8614-11 as shown in "Drive Pinion - Removal".
10. Install washer and nut onto pinion shaft. Torque nut to 350 N·m (250 lbs.) ft.
11. Remove holding bar and with an inch pound torque wrench measure rotating torque. Rotating torque should be 10 to 20 in. lbs. with original bearings or 20 to 40 in. lb. with new bearings. Torque reading to start shaft turning must be disregarded.
12. If torque requirements (preload) are not to specifications, adjust shim pack as necessary.
  - To increase preload, decrease the thickness of preload shims.
  - To decrease preload, increase the thickness of preload shims.
13. When bearing preload meets specifications, remove nut, washer and flange from pinion shaft.
14. Install new pinion oil seal into housing as shown in figure 4B3-11, using J-24384.
15. Install flange, washer and nut. Using holder bar

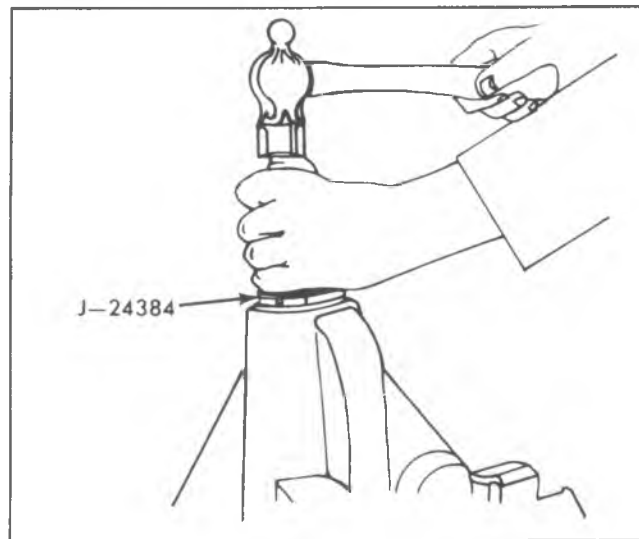

Fig. 4B3-11--Installing Pinion Oil Seal

J-8614-11, torque nut to 350 N·m (250 lbs. ft.).

## DIFFERENTIAL CASE

### Installation and Adjustment

1. Place the differential case, with side bearings and cups installed, into position in the carrier.
2. Select the smallest of the original shims as a "gaging" shim and place it between the bearing cup and the carrier on the ring gear side of the case.
3. Install bearing caps and bearing screws finger tight. Make sure bearing caps are in correct marked position.
4. Mount a dial indicator on the ring gear side of the carrier, with the indicator probe in contact with the back face of the ring gear.
5. Position two screwdrivers between the bearing cup and the carrier on the side opposite the ring gear.
6. Pull on the screwdrivers and force the differential case as far as possible toward the indicator. With force still applied, set the dial indicator to zero.
7. Reposition the screwdrivers on the ring gear side of the case. Force the ring gear into mesh with the drive pinion and observe the dial indicator. Repeat this operation several times until the same reading is obtained.
8. Add the indicator reading to the 'gaging' shim thickness to determine the correct shim dimension for installation on the ring gear side of the case.  
For example, if the gaging shim was .155 inch, and the indicator reading in step 7 was .017 inch, the correct shim would be  $.155 + .017 = .172$  inch.
9. Remove the "gaging" shim and install the correct size shim into position between the bearing cup and the carrier on the ring gear side of the case.
10. To determine the correct dimension for the remaining shim, first refer to the dimension obtained in step 8 of "Gaging Procedures and Side Bearing Shims". From that figure, subtract the size of the shim installed in step 9 above; then add .006 inch for preload and backlash.  
For example, if the reading in step 8 was .329 inch, and the shim just installed on the ring gear side of the case

was .172 inch, the correct shim dimension would be  $.329 - .172 = .157 + .006 = .163$  inch.

11. Spread the differential carrier as shown in figure 4B3-2.
12. Assemble the shim determined in step 10 into place between the bearing cup and the carrier.
13. Remove the spreader and the dial indicator.
14. Install the bearing caps in marked positions and torque cap screws to specifications.
15. Install dial indicator and check ring gear backlash at four equally spaced points around the ring gear. Backlash must be held to .004" to .009" and must not vary more than .002" between positions checked.
16. Whenever backlash is not within limits, differential bearing shim pack should be corrected to bring backlash within limits.
  - Low backlash is corrected by decreasing the shim on the ring gear side and increasing the opposite side shim **an equal amount**.
  - High backlash is corrected by increasing the shim on the ring gear side and decreasing the opposite side shim **an equal amount**.
17. Check gear tooth contact, as described in 'Gear Tooth Contact Pattern Check' in Section 4B.
18. Using a new gasket, install housing cover and torque bolts to specifications.
19. Reinstall the rear universal joint, and torque 'U' bolt nuts to specifications.
20. Install axles into carrier and axle flange over hub studs.
21. Torque hub stud nuts to specifications.
22. Fill differential with lubricant.
23. Install wheel and tire assembly.

## OPERATIONAL CHECKS AND ADJUSTMENTS

Four adjustments are essential for proper operation of the differential and its related parts. These adjustments are a) Pinion Bearing Preload, b) Side Bearing Preload, c) Pinion Depth and d) Ring Gear-to-Pinion Backlash.

Refer to Section 4B for description of how to perform these checks and adjustments.



## SECTION 4B4

# DANA 9-3/4" RING GEAR AXLE

The following notice applies to one or more steps in the assembly procedure of components in this portion of the manual as indicated at appropriate locations by the terminology "See Notice on Page 1 of this Section".

**NOTICE:** This fastener is an important attaching part in that it could affect the performance of vital components and systems, and/or could result in major repair expense. It must be replaced with one of the same part number or with an equivalent part if replacement becomes necessary. Do not use a replacement part of lesser quality or substitute design. Torque values must be used as specified during reassembly to assure proper retention of this part.

### CONTENTS

|   |       |  |       |
|---|-------|--|-------|
| On-Vehicle Service . . . . .                        | 4B4-1 | Differential Case-Reassembly . . . . .                   | 4B4-6 |
| Unit Repair . . . . .                               | 4B4-1 | Drive Pinion-Installation and Adjustment . . . . .       | 4B4-4 |
| Differential Case-Removal and Disassembly . . . . . | 4B4-1 | Differential Case-Installation and Adjustments . . . . . | 4B4-6 |
| Drive Pinion-Removal and Disassembly . . . . .      | 4B4-2 | Operational Checks and Adjustments . . . . .             | 4B4-6 |

## ON-VEHICLE SERVICE

### AXLE ASSEMBLY

The axle assembly removal and installation is identical to the procedure given earlier for "Chevrolet 10-1/2" Ring Gear Axle".

Drive pinion oil seal replacement requires different special tools for the Dana axle. Use J-22281 for pinion oil seal replacement.

### UNIT REPAIR

This Dana Spicer axle is similar in design to other Salisbury type axles with the following exceptions:

- The differential side bearing shims are located between the side bearing cone and roller assembly and the differential case. See figure 4B4-1. These bearings are of the tapered roller design and are preloaded. In order to remove the differential case the carrier must be spread.
- The pinion assembly incorporates an inner and outer bearing shim. The inner shim is used to maintain proper pinion depth. The outer shim is used to maintain proper preload on the pinion bearing.

5. Remove cap screws and lock washers attaching cover to carrier. Remove cover and gasket.
6. Mark one side of carrier and matching cap for reassembly. Remove cap screws attaching bearing caps to carrier.
7. Using spreader Tool J-24385 and dial indicator as shown in figure 4B4-2, spread carrier a maximum of .015".  
**NOTICE:** Do not exceed this dimension as carrier may be permanently damaged.
8. Remove dial indicator and with the use of a pry bar remove differential case from carrier. Remove spreader.

### DIFFERENTIAL CASE

#### Removal

1. Place vehicle on hoist with rear axle hanging free.
2. Remove wheel and tire assemblies.
3. The axle shafts are full-floating type with flanged outer end of shaft attached to wheel hub by studs and nuts. Wheel is supported by tapered roller bearings at outer end of axle housing.
  - a. Remove axle shaft to hub attaching nuts.
  - b. Rap on axle shaft to loosen shaft from hub and remove shafts.
4. Remove plug in carrier and drain lubricant.

#### Disassembly

1. Remove differential bearing cups and identify with a tag for reassembly.
2. Place differential in vise and drive out pinion shaft lock pin.
3. Remove differential bearing cone and roller using Puller J-29721 4B4-3. Tag cone and rollers for assembly.  
If ring gear and pinion are to be reassembled, note position of shims and replace accordingly.
4. Remove spacer, pinion shaft, pinions, side gears and thrust washers from differential case.
5. Remove screws attaching ring gear to differential case. Remove gear.

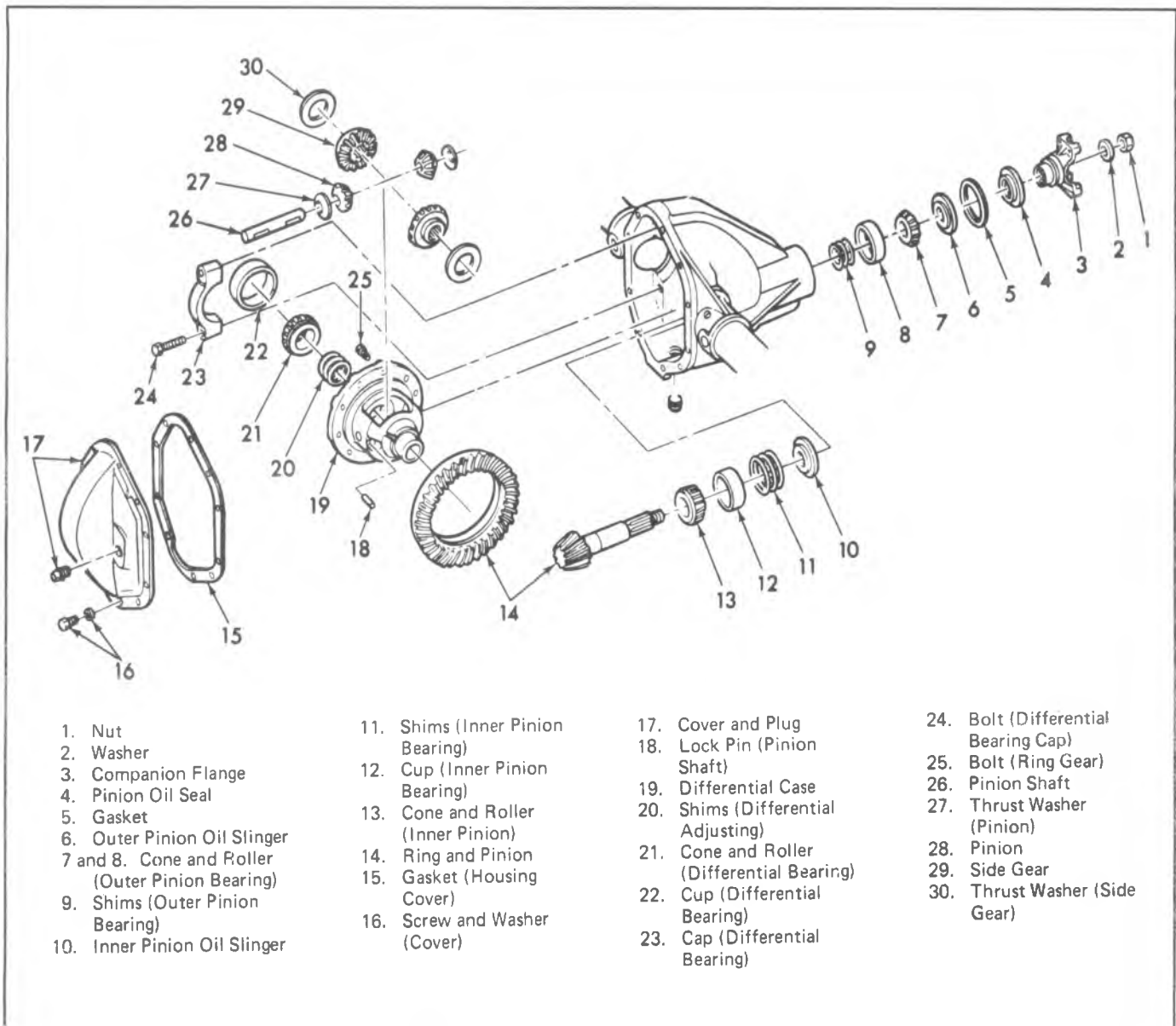

Fig. 4B4-1—Dana Differential With 9-3/4" Ring Gear - Exploded View

## DRIVE PINION

### Removal

1. Separate rear universal joint, tape trunnion bearings to joint, position propeller shaft to one side and tie propeller shaft to frame side rail.
2. Using Holding Bar J-8614-11, attach d to pinion shaft flange, remove self-locking nut and washer from pinion shaft.
3. Install Tool J-8614-2, and 3 into holding bar as shown in figure 4B4-4 and remove flange from drive pinion. Remove drive pinion from carrier.
4. With a long drift, tap on inner race of outer pinion bearing to remove pinion oil seal, slinger, gasket, outer pinion cone and roller and shim pack. Tag shim pack for reassembly.
5. Should inspection indicate necessity, pinion bearing cups can be removed from carrier using long drift and hammer. Remove shims and oil slinger which are

located behind the inner bearing cup. Tag shims for reassembly.

6. Remove inner pinion cone and roller using Tool J-22912, installed as shown in Figure 4B4-5, and press pinion from bearing.

### Inspection

1. Clean all gears and bearings in cleaning solvent and inspect all bearing cups, races and rollers for scoring, chipping or evidence of excessive wear. On pinion bearing rollers, inspect large end of rollers for wear. This is where wear is most evident on tapered roller bearings.  
The pinion bearings are of the tapered type, and the natural wear pattern is a frosted condition with occasional slight scratches on races or rollers. This does not indicate a defective bearing.
2. Inspect pinion splines and flange splines for evidence of excessive wear.
3. Inspect ring gear and pinion teeth for possible scoring, cracking or chipping.

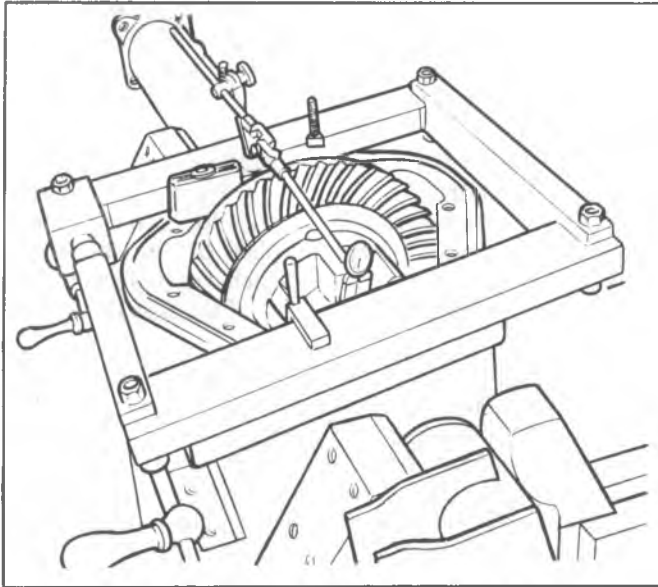

Fig. 4B4-2--Tool J-24385 Mounted on Carrier

4. Inspect differential case for cracks or scores. Inspect side gears, thrust washers, and pinion thrust faces.
5. Check fit of differential side gears in case.
6. Check fit of side gears and axle shaft splines.
7. Inspect differential pinion shaft and spacer for scoring or evidence of excessive wear.

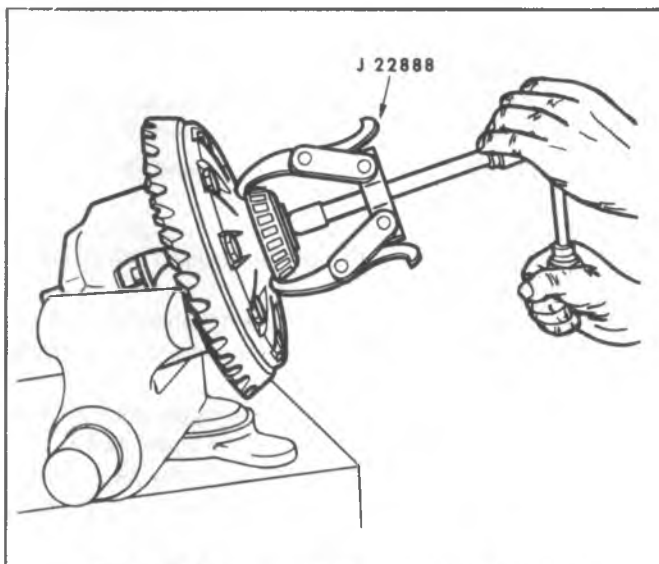

Fig. 4B4-3--Removing Differential Side Bearings

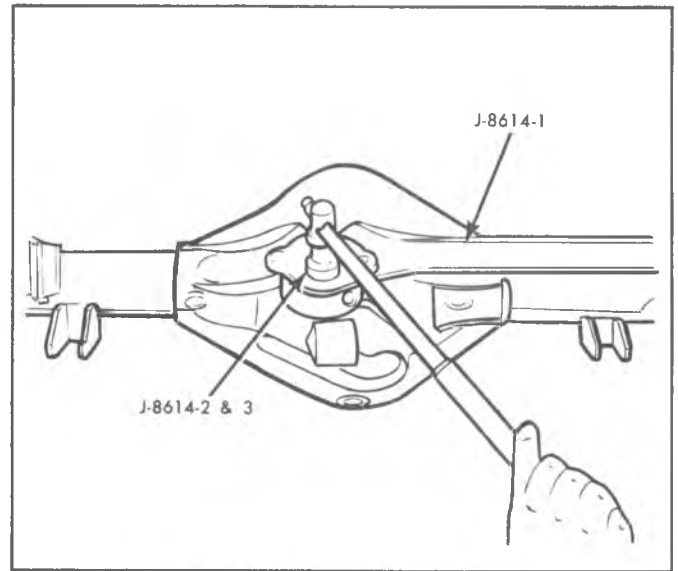

Fig. 4B4-4--Removing Pinion Flange

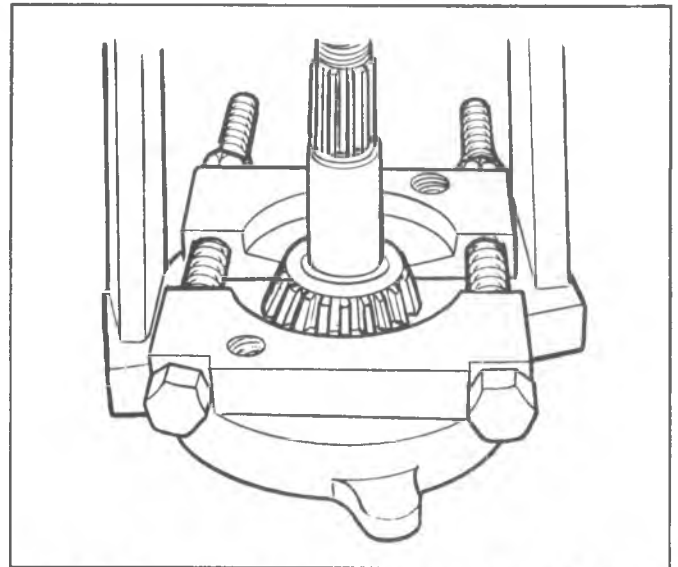

Fig. 4B4-5--Removing Inner Pinion Bearing Cone and Roller

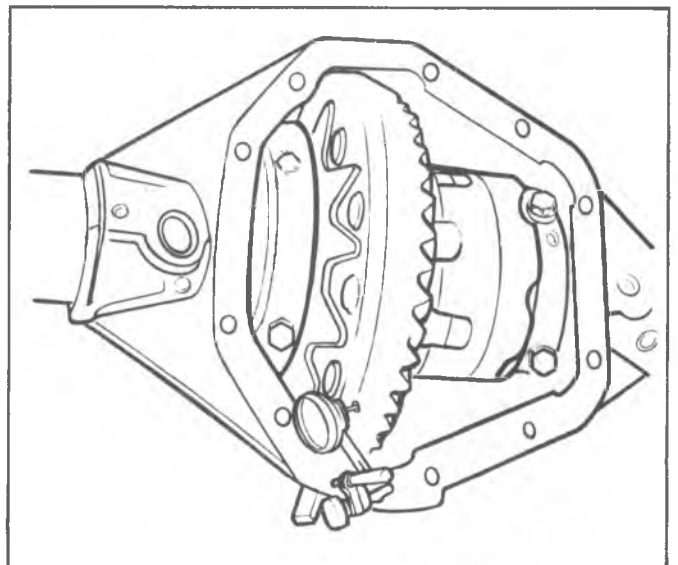

Fig. 4B4-6--Checking Runout

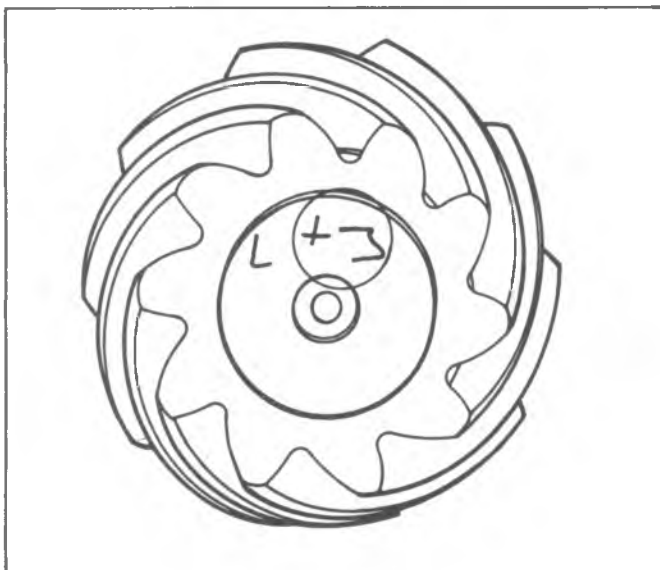

Fig. 4B4-7--Marking From Nominal on Pinion

1. Position differential side gears and new thrust washers in differential case.
2. Position differential pinions and new thrust washers in differential case. Align pinions with holes in differential case.
3. Install pinion shaft in differential case. Align hole in shaft with hole in case, then install lock pin. Peen hole to prevent pin dropping out of case.
4. Position ring gear to case, then install cap screws. Tighten cap screws evenly and alternately to specifications.
5. With an arbor press, press differential side bearings onto case using Tool J-21051. Do not install shims at this time.
6. Place differential case in carrier and install bearing caps. Care should be taken to install caps in original position. Use mark placed on caps and carrier at removal. Tighten caps just enough to keep bearing caps in place.
7. Install dial indicator on carrier with indicator button contacting back of ring gear, as in figure 4B4-6. Rotate differential case and check for runout. If runout is greater than .002", the assembly should be removed and the ring gear removed from the case. Again install differential case and check runout at differential case flange.
8. Should runout of case flange be greater than .002" the defect is probably due to bearings or differential case, and should be corrected before proceeding further.
9. Position two screwdrivers between bearing cup and carrier on opposite side of ring gear (away from dial indicator side). Pull on screwdrivers and force differential case as far as possible toward the dial indicator. Rock the ring gear to set the bearings. With force still applied, set indicator at "0".
10. Reposition screwdrivers between bearing cup and carrier on ring gear side. Pull on screwdrivers and force differential case as far as possible toward center of carrier. Record the indicator reading. This will be the

total amount of shims needed (less preload) for setting backlash later during assembly.

11. Remove differential from carrier.

## DRIVE PINION

### Installation and Adjustment of Depth and Preload

Ring gears and pinions are supplied in matched sets only. Matching numbers on both pinion and ring gear are etched for verification. If a new gear set is being used, verify the numbers of each pinion and ring gear before proceeding with assembly.

On the button end of each pinion there is etched a plus (+) number, a minus (-) number, or a zero (0) number, which indicates the best running position for each particular gear set. This dimension is controlled by the shimming behind the inner bearing cup. Whenever baffles or oil slingers are used, they become a part of the adjusting shim pack.

For example: If a pinion is etched +3, this pinion would require .003" less shims than a pinion etched "0". This means by removing shims, the mounting distance of the pinion is increased by .003" which is just what a +3 etching indicates. Or if a pinion is etched -3, we would want to add .003" more shims than would be required if the pinions were etched "0". By adding .003" shims, the mounting distance of the pinion was decreased .003" which is just what a -3 etching indicated. See figure 4B4-7.

If the old ring and pinion set is to be reused, measure the old shim pack and build a new shim pack to this same dimension. If baffle is in the axle assembly, it is considered as part of the shim pack.

To change the pinion adjustment, shims are available in thicknesses of .003", .005" and .010".

If baffle or slinger is bent or mutilated, it should be replaced.

Measure each shim separately with a micrometer and add together to get total shim pack thickness from original build up.

If a new gear set is being used, notice the plus or minus etching on both the old and new pinion, and adjust the thickness of the old shim pack to compensate for the difference of these two figures.

For example: If the old pinion reads (+2) and the new pinion is (-2), add .004" shims to the original shim pack.

1. Determine proper inner shim pack (for setting pinion depth) by using chart in figure 4B4-8.
2. Install inner shim pack and oil slinger in inner cup bore and drive inner cup into position using Tool J-21059 used with J-8092.
3. To the outer shim pack (for setting preload) add or remove an equal amount as was added or removed from the inner shim pack.
4. Install outer cup in carrier bore, using installer J-7818 with Drive Handle J-8092 as shown in figure 4B4-9.
5. Press inner pinion bearing cone and roller onto pinion shaft using Installer J-9772 on arbor press as shown in figure 4B4-10.
6. Install drive pinion and inner bearing cone and roller assembly in differential carrier.
7. Install shims and outer pinion cone and roller on pinion shaft using Tool J-5590 and companion flange to press bearing onto pinion, as in figure 4B4-11.

| Old Pinion Marking | New Pinion Marking |         |         |         |         |         |         |         |         |
|--------------------|--------------------|---------|---------|---------|---------|---------|---------|---------|---------|
|                    | - 4                | - 3     | - 2     | - 1     | 0       | + 1     | + 2     | + 3     | + 4     |
| + 4                | + 0.008            | + 0.007 | + 0.006 | + 0.005 | + 0.004 | + 0.003 | + 0.002 | + 0.001 | 0       |
| + 3                | + 0.007            | + 0.006 | + 0.005 | + 0.004 | + 0.003 | + 0.002 | + 0.001 | 0       | - 0.001 |
| + 2                | + 0.006            | + 0.005 | + 0.004 | + 0.003 | + 0.002 | + 0.001 | 0       | - 0.001 | - 0.002 |
| + 1                | + 0.005            | + 0.004 | + 0.003 | + 0.002 | + 0.001 | 0       | - 0.001 | - 0.002 | - 0.003 |
| 0                  | + 0.004            | + 0.003 | + 0.002 | + 0.001 | 0       | - 0.001 | - 0.002 | - 0.003 | - 0.004 |
| - 1                | + 0.003            | + 0.002 | + 0.001 | 0       | - 0.001 | - 0.002 | - 0.003 | - 0.004 | - 0.005 |
| - 2                | + 0.002            | + 0.001 | 0       | - 0.001 | - 0.002 | - 0.003 | - 0.004 | - 0.005 | - 0.006 |
| - 3                | + 0.001            | 0       | - 0.001 | - 0.002 | - 0.003 | - 0.004 | - 0.005 | - 0.006 | - 0.007 |
| - 4                | 0                  | - 0.001 | - 0.002 | - 0.003 | - 0.004 | - 0.005 | - 0.006 | - 0.007 | - 0.008 |

Fig. 4B4-8--Dana Pinion Code Chart

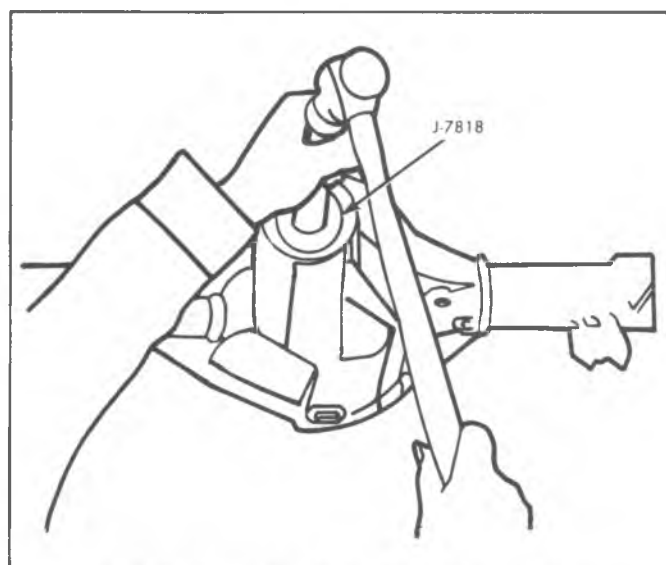

Fig. 4B4-9--Installing Outer Pinion Bearing Cup

8. Install flange holding bar and install washer and nut on pinion shaft. Torque nut to 355 N·m (255 ft. lbs.).
9. Remove holding bar and with an inch pound torque wrench measure rotating torque. Rotating torque should be 10 to 20 in. lbs. with original bearings or 20 to 40 in. lb. with new bearings.

Torque reading to start shaft turning must be disregarded.

10. If torque requirements (preload) are not to specifications, adjust shim pack as necessary.
  - Increase the outer shim pack to reduce rotation torque.
  - Decrease shim pack to increase rotating torque.
11. Remove nut, washer and flange from pinion shaft.
12. Install oil slinger, gasket and using Tool J-22804 install oil seal.
13. Install flange, washer and nut. Torque nut to specifications.

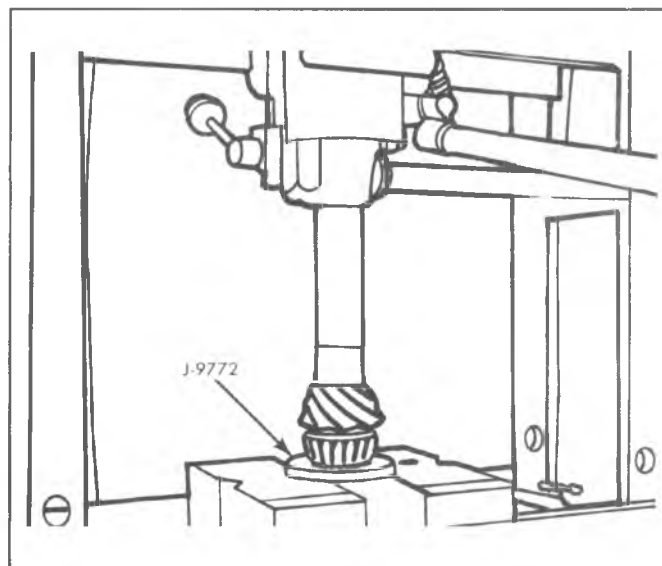

Fig. 4B4-10--Installing Inner Pinion Cone and Roller

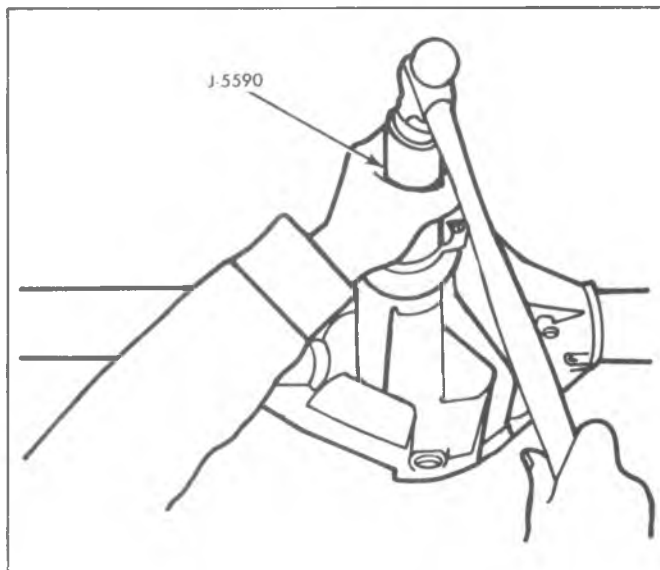

Fig. 4B4-11--Installing Pinion Flange

## DIFFERENTIAL CASE

### Preload and Adjustment

1. Place differential assembly (with pinion assembled) into housing. Install bearing caps in their proper position and tighten screws just enough to hold the bearing cups in place.
2. Install dial indicator on carrier with indicator button contacting back of ring gear, as in figure 4B4-6.
3. Place two screwdrivers between bearing cup and housing on ring gear side of case, and pry ring gear into mesh with pinion gear as far as it will go. Rock ring gear to allow bearings to seat and gears to mesh. With force still applied, set indicator to "0".
4. Reposition screw drivers on opposite side of ring gear and pry ring gear as far as it will go. Now take an indicator reading. Repeat until the same reading is obtained every time. This reading will be the necessary amount of shims between the differential case and differential bearing on the ring side gear. Remove differential bearing from the ring side and assemble proper amount of shims. Reassemble bearing.
5. Remove the differential bearing from the opposite side of ring gear. To determine the amount of shims needed here, use the following method.
  - a. Subtract the size of shim pack just installed on ring gear side of case from the reading obtained and recorded in step 10 of Differential Case-Reassembly.
  - b. To this figure, add an additional .015" shims to compensate for preload and backlash.
 

Example: If reading in step 10 of Differential Case-Reassembly was .085", and the shims installed on ring gear side of case was .055", the correct amount of shim will be  $.085" - .055" + .015" = .045"$ .
6. Install shims as indicated in step 5, (which will give the proper bearing preload and backlash) and install side bearing.

### Installation

1. Spread differential carrier, using spreader as shown in figure 4B4-2.
2. Install differential bearing outer races in their correct location, then install differential case into carrier.
3. Install differential bearing caps in the correct location as indicated by marks made at disassembly. Install cap screws finger tight. Rotate differential assembly and rap on case with a soft faced hammer to insure proper seating of case in carrier.
4. Remove spreader and torque cap bolts to specifications.
5. Install dial indicator and check ring gear backlash at four equally spaced points around the ring gear. Backlash must be held to .004" to .009" and must not vary more than .002" between positions checked.
6. Whenever backlash is not within limits, differential bearing shim pack should be corrected to bring backlash within limits.
7. Perform Operational Checks and Adjustments.
8. Using a new gasket, install housing cover and torque bolts to specifications.
9. Reinstall the rear universal joint, and torque "U" bolt nuts to specifications.
10. Install axles into carrier and axle flange over hub studs. Torque hub stud nuts to specifications.
11. Fill differential with lubricant.
12. Install wheel and tire assembly.

**CAUTION: See Caution on page 1 of this section regarding the fasteners referred to in the above steps.**

## OPERATIONAL CHECKS AND ADJUSTMENTS

Four adjustments are essential for proper operation of the differential and its related parts. These adjustments are a) Pinion Bearing Preload, b) Side Bearing Preload, c) Pinion Depth and d) Ring Gear-to-Pinion Backlash.

Refer to Section 4B for description of how to perform these checks and adjustments.

## SECTION 4B5

**ROCKWELL 12" RING GEAR AXLE**

**NOTICE:** All rear axle attaching fasteners are an important attaching part in that it could affect the performance of vital components and systems, and/or could result in major repair expense. It must be replaced with one of the same part number or with an

equivalent part if replacement becomes necessary. Do not use a replacement part of lesser quality or substitute design. Torque values must be used as specified during reassembly to assure proper retention of this part.

**CONTENTS**

|                                     |       |                                       |        |
|-------------------------------------|-------|---------------------------------------|--------|
| General Description .....           | 4B5-1 | Pinion and Cage Assembly.....         | 4B5-5  |
| On-Vehicle Service .....            | 4B5-3 | Removal .....                         | 4B5-5  |
| Axle Assembly .....                 | 4B5-3 | Disassembly.....                      | 4B5-6  |
| Axle Vent .....                     | 4B5-3 | Cleaning and Inspection .....         | 4B5-6  |
| Axle Shaft .....                    | 4B5-3 | Reassembly .....                      | 4B5-7  |
| Wheel Bolt Replacement.....         | 4B5-3 | Gear Set Identification .....         | 4B5-7  |
| Bearing Adjustment.....             | 4B5-3 | Pinion and Cage Assembly.....         | 4B5-9  |
| Drive Pinion Oil Seal.....          | 4B5-3 | Selecting Pinion Shims .....          | 4B5-10 |
| Differential Carrier.....           | 4B5-3 | Differential and Gear .....           | 4B5-10 |
| Removal .....                       | 4B5-3 | Checking Rolling Resistance.....      | 4B5-11 |
| Installation .....                  | 4B5-4 | Installing Bearing Cups.....          | 4B5-12 |
| Unit Repair .....                   | 4B5-4 | Installing Differential and Gear..... | 4B5-12 |
| Differential and Gear Assembly..... | 4B5-4 | Adjusting Bearing Preload .....       | 4B5-13 |
| Removal .....                       | 4B5-4 | Installing Thrust Screw .....         | 4B5-13 |
| Disassembly.....                    | 4B5-5 | Specifications and Torque .....       | 4B5-15 |

**GENERAL DESCRIPTION**

Fig. 4B5-1--Single-Reduction Carrier

The Rockwell Single-Reduction Final Drive (Fig. 4B5-1) employs a heavy duty hypoid drive pinion and ring gear. The differential and gear assembly is mounted on tapered roller bearings. The straddle mounted pinion has two tapered roller bearings in front of the pinion teeth which take the forward and reverse thrust and a third bearing behind the pinion teeth to carry the radial load.

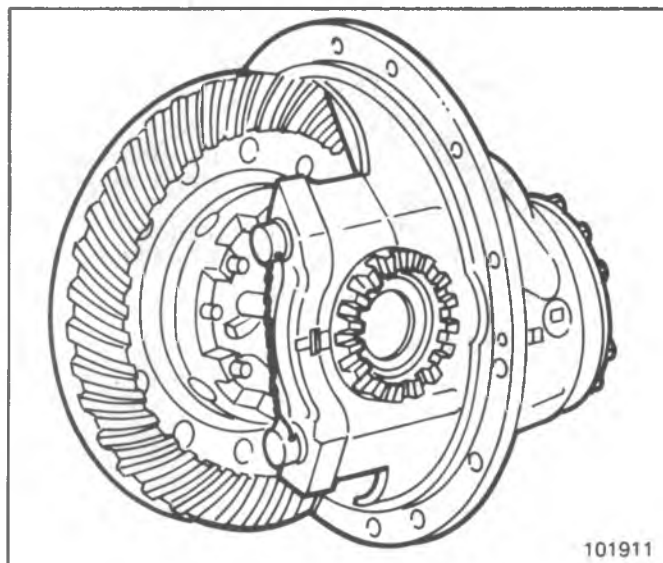
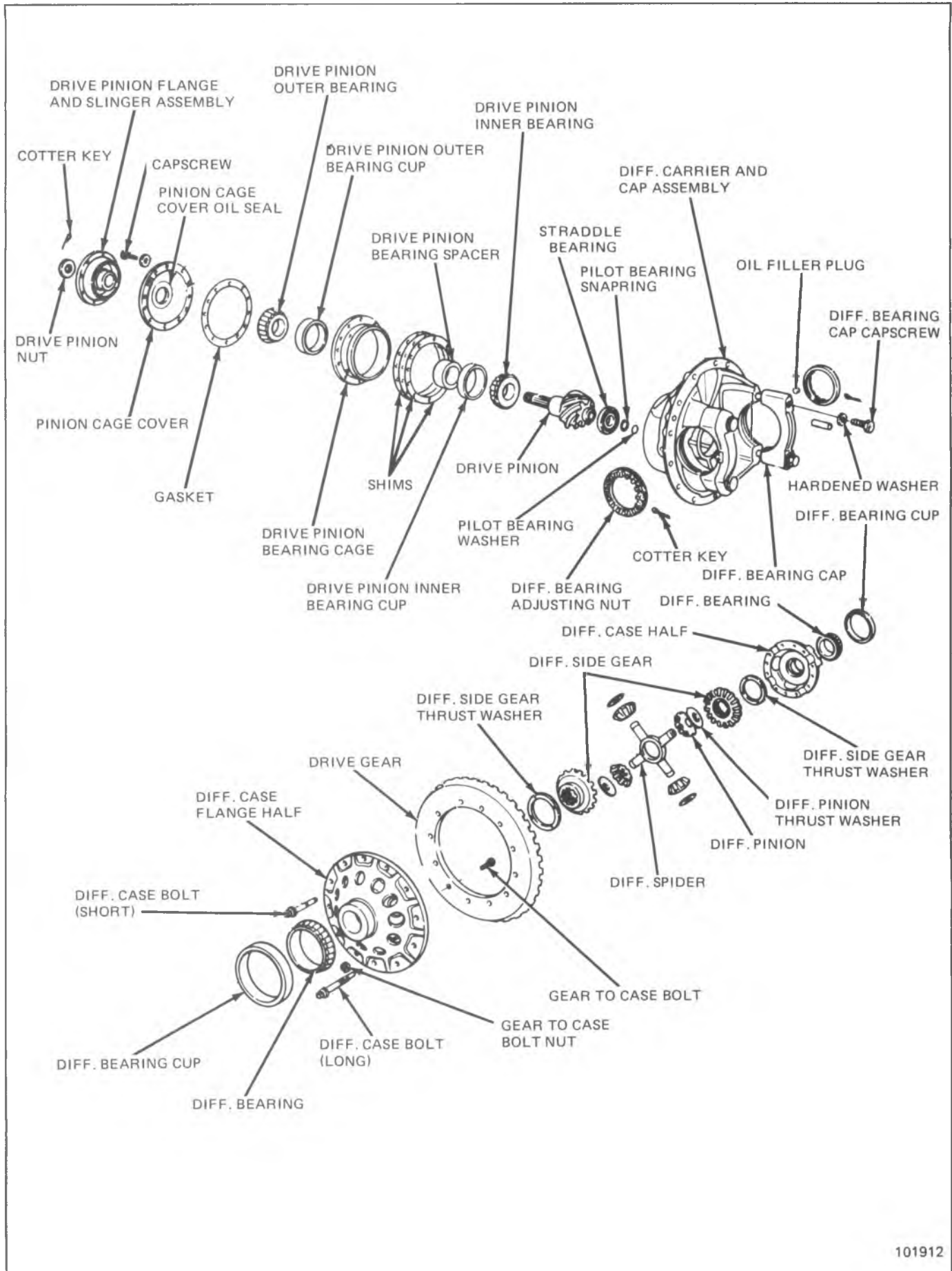

101912

Fig. 4B5-2--Rockwell Assembly



## ON-VEHICLE SERVICE

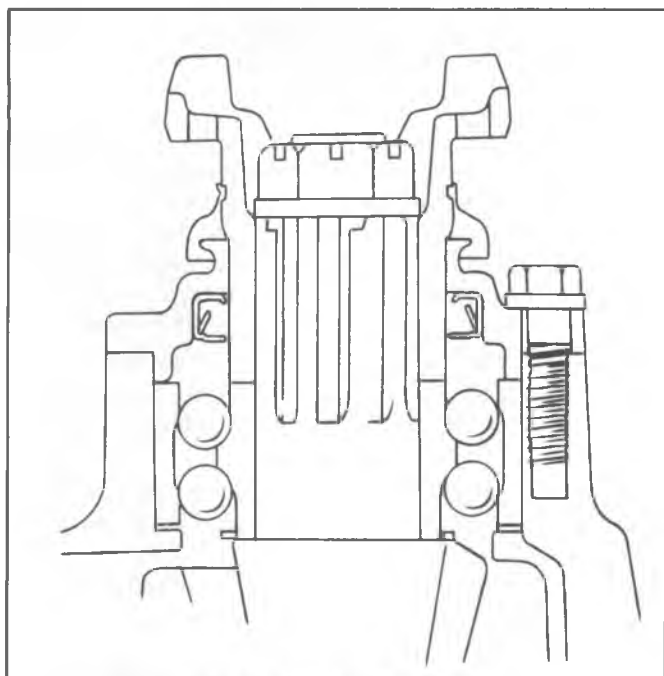

Fig. 4B5-2a -- Pinion Oil Seal

### AXLE ASSEMBLY

The axle assembly removal and installation is identical to the procedure for the "Chevrolet 10-1/2" Ring Gear Axle" (Section 4B2).

### AXLE VENT

#### Replacement

If axle vent requires replacement, pry old vent from housing being sure that entire vent is removed. Prick punch around carrier hole to insure fit of replacement vent. Tap new vent into housing using a soft-faced hammer. Vent should be positioned in housing so that flat surface is toward centerline of differential carrier.

### AXLE SHAFT

#### Replacement

1. Remove hub cap, and install Tool J-8117 in tapped hole on shaft flange.
2. Install slide hammer, Tool J-2619, and remove axle shaft.
3. Thoroughly remove old gasket material from hub and hub cap. Clean shaft flange and mating surfaces in the wheel hub.
4. Install axle shaft so that the flange splines index into hub splines. Tap shaft into position, using J-8117 and J-2619.
5. Install new gasket, position flange to hub and install attaching bolts. Torque bolts to specifications.

### WHEEL BOLT REPLACEMENT

Refer to procedure listed under "Chevrolet 10-1/2" Ring Gear Axle (Section 4B2).

### BEARING ADJUSTMENT

Before checking bearing adjustment, make sure brakes are fully released and do not drag.

Check bearing play by grasping tire at top and pulling back and forth, or by using a pry bar under tire. If bearings are properly adjusted, movement of brake rotor will be barely noticeable and wheel will turn freely. If movement is excessive, adjust bearing as follows:

1. Remove axle shaft and raise vehicle until wheel is free to rotate.
2. Disengage tang of retainer from locknut and remove both locknut and retainer from axle housing tube with tool J-25510.
3. Use J-25510 to tighten inner adjusting nut at the same time rotating hub to make sure all bearing surfaces are in contact. Then back off inner nut to specified amount of turn-back.
4. Install tanged retainer against the inner adjusting nut. Align inner adjusting nut so short tang of retainer will engage nearest slot on inner adjusting nut.
5. Install outer locknut and tighten to correct specified torque. Then bend long tang of retainer into slot of outer nut. This method of adjustment will result in the proper bearing adjustment.

### DRIVE PINION OIL SEAL

#### Replacement

The pinion oil seal may be replaced with the carrier assembly installed in the vehicle.

1. Disconnect propeller shaft.
2. Scribe a line down the pinion stem, pinion nut and companion flange.
3. Use J-8614-11 to remove the pinion nut and the companion flange.
4. Remove the bolts retaining the oil seal retainer to the carrier, and remove the retainer. See Figure 4B5-2a.
5. Pry the oil seal from the bore, using care not to damage the machined surfaces. Thoroughly clean all foreign material from contact area.
6. Lubricate the cavity between the seal lips with a high melting point bearing lubricant.
7. Install a new pinion oil seal into the bore, using J-22281. Be sure seal bottoms against shoulder in bore.
8. Install the bearing retainer to the carrier.
9. Reinstall the companion flange, pinion nut and propeller shaft.

### DIFFERENTIAL CARRIER

#### Removal (Fig. 4B5-3)

1. Remove plug from bottom of axle housing and drain lubricant.
2. Remove the axle shaft from the drive unit and housing.
3. Disconnect universal at pinion shaft.

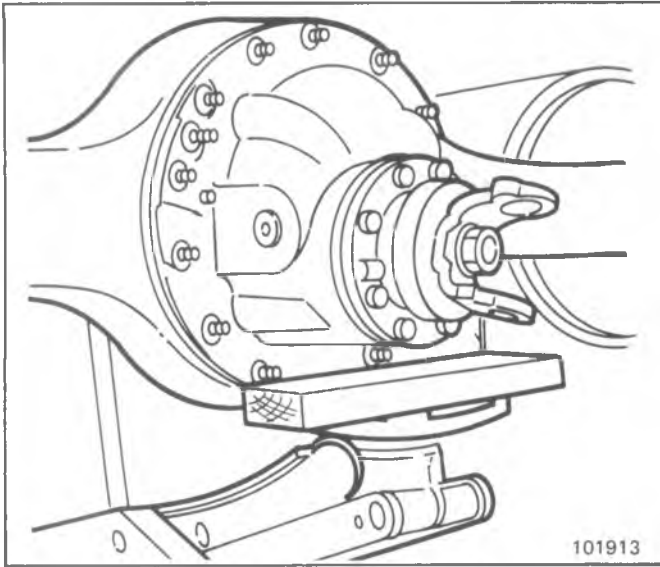

Fig. 4B5-3--Carrier Removal

4. Remove carrier to housing stud nuts and washers. Loosen two top nuts and leave on studs to prevent carrier from falling.
5. Break carrier loose from axle housing with rawhide mallet.

6. Remove top nuts and washers and work carrier free. A small pinch bar may be used to straighten the carrier in the housing bore. However, the end must be rounded to prevent indenting the carrier flange. Use a roller jack to safely remove carrier from housing (Fig. 4B5-3).

### Installation

1. Remove any accumulation of dirt, grit or gum from housing bowl and sleeves. Clean housing thoroughly with solvent and blow dry with compressed air.
2. Inspect housing for cracks, loose studs, nicks and burrs at machined surfaces. Remove nicks and burrs with stone or file. Make all necessary repairs or parts replacement before installing drive unit in housing.
3. Install drive unit to housing gasket over housing studs. Roll carrier into position on roller jack. Start carrier into housing with four flat washers and nuts equally spaced.  
**NOTICE:** Do not drive carrier into housing with a hammer at the carrier stud flange. The flange may easily be distorted and cause severe oil leakage. Install lock washers and stud nuts on any studs under carrier housing offsets. It is impossible to start these nuts after carrier is drawn into housing.
4. Tighten the four nuts over flat washers alternately to draw carrier squarely into axle housing.
5. Connect universal at pinion shaft.
6. Install axle shafts.

## UNIT REPAIR

### DIFFERENTIAL CASE AND GEAR ASSEMBLY

Place carrier in suitable holding fixture as illustrated (Fig. 4B5-4).

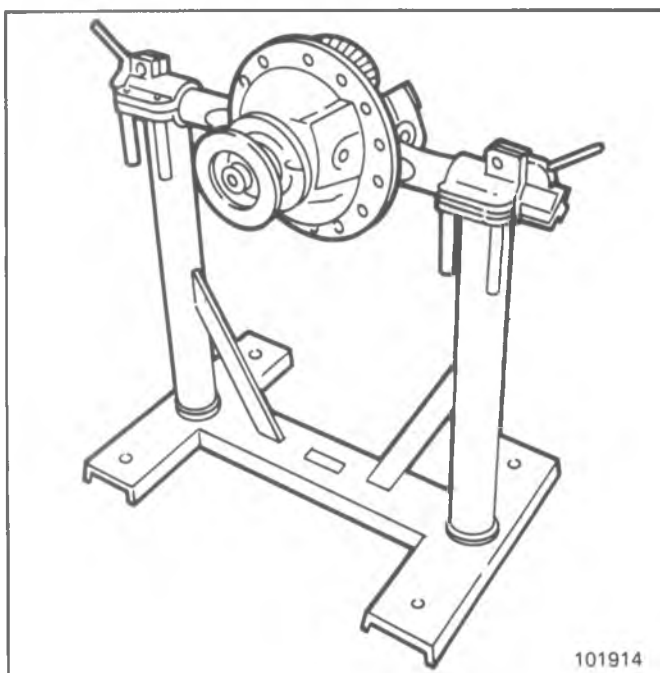

Fig. 4B5-4--Carrier In Repair Stand

If the initial inspection indicates that the drive gear is not going to be replaced, the established backlash should be measured and noted for reference and used at reassembly.

### Removal

1. Loosen jam nut and back off thrust adjusting screw (Fig. 4B5-5).
2. Center punch one differential carrier leg and bearing cap to identify for properly reassembling (Fig. 4B5-6).
3. Remove capscrews and adjusting nut locks.

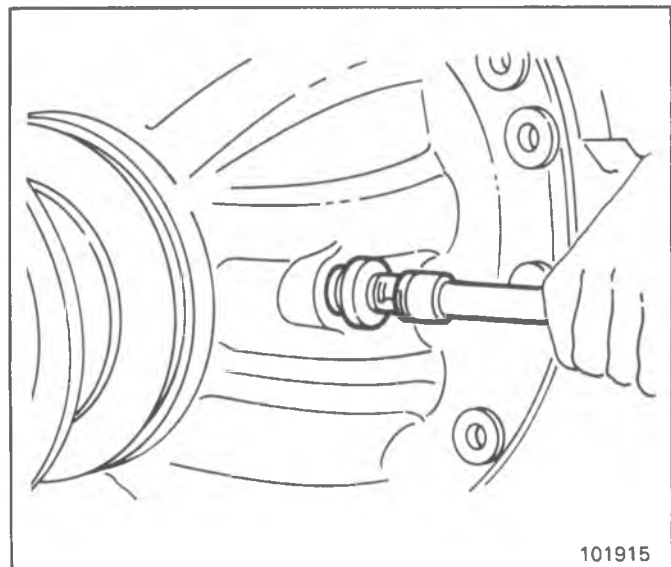

Fig. 4B5-5--Thrust Adjusting Screw

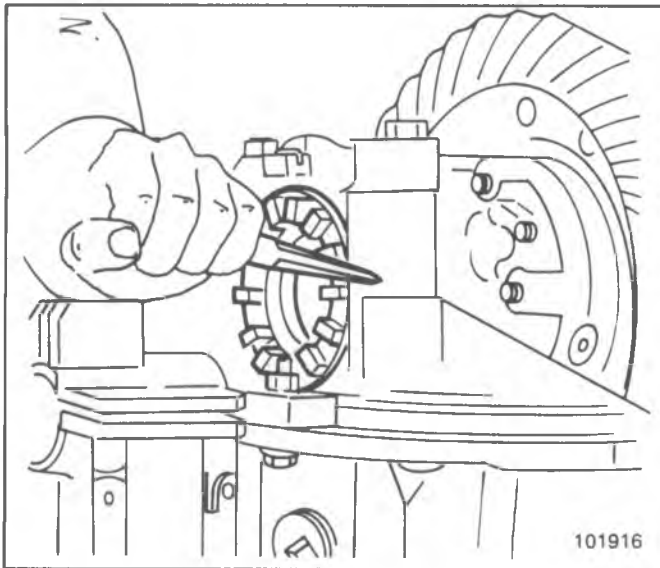

Fig. 4B5-6--Punching Carrier Leg

4. Remove bearing cap, capscrews, bearing caps and adjusting nuts.
5. Lift out differential and gear assembly.

**Disassembly**

If original identification marks are not clear, mark differential case halves with a punch or chisel for correct alignment when reassembling (Fig. 4B5-8).

1. Remove bolts and separate case halves.
2. Remove spider, pinions, side gears and thrust washers.
3. If necessary, remove rivets and separate gear and case.

**Rivet Removal (Fig. 4B5-9)**

1. Carefully center punch rivets in center of head.
2. Use drill 1/32" smaller than body of rivet to

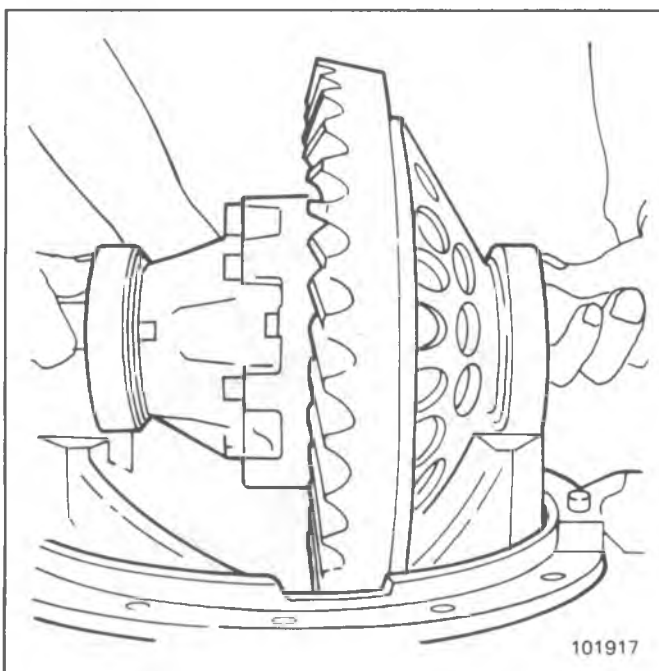

Fig. 4B5-7--Lifting Differential

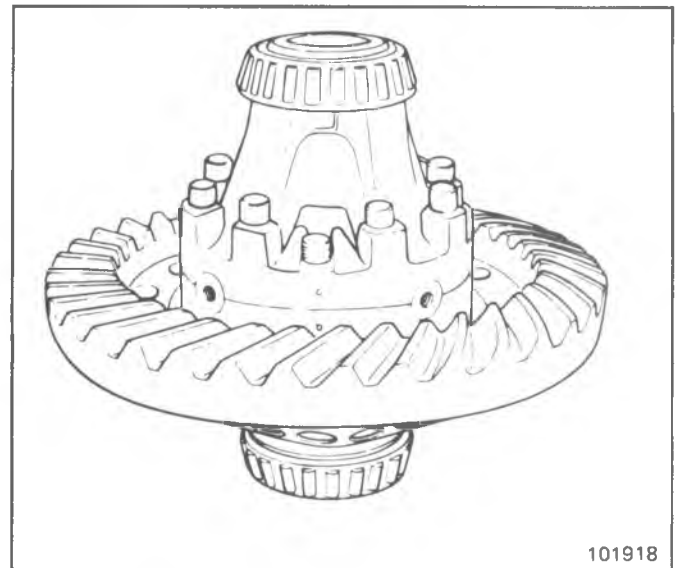

Fig. 4B5-8--Identification Mark

- drill completely through rivet.
  3. Press out rivets.
- If necessary to replace differential bearings, remove with a suitable puller and/or press (Fig. 4B5-10).

**Pinion and Cage Assembly Removal**

1. Hold flange with suitable tool and remove pinion shaft nut and washer (Fig. 4B5-11).
  2. Remove flange with a suitable puller (Fig. 4B5-12).
- NOTICE:** Driving the flange off will cause runout.
3. Remove pinion cage capscrews.
  4. Remove bearing cover and oil seal assembly.
- If necessary to replace oil seal drive seal out and then press in new seal with tool.
5. Remove drive pinion bearing cage (Fig. 4B5-13). Original may have puller holes.

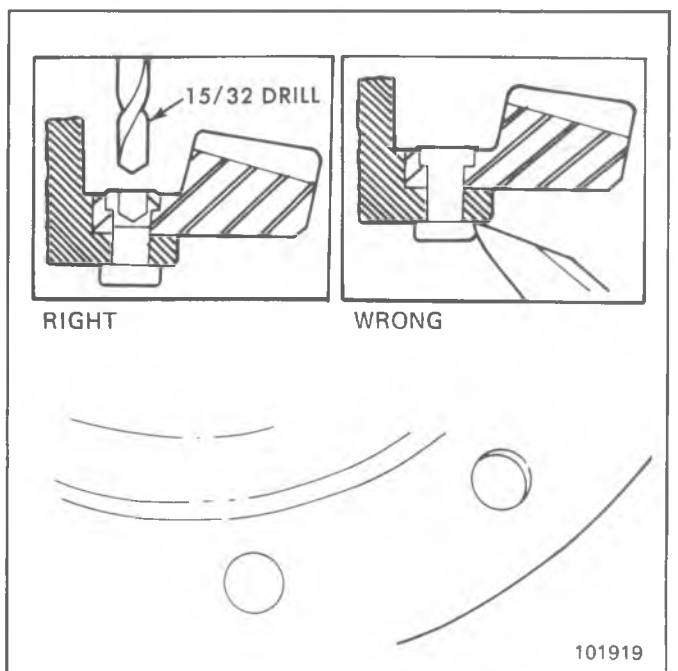

Fig. 4B5-9--Removing Rivets

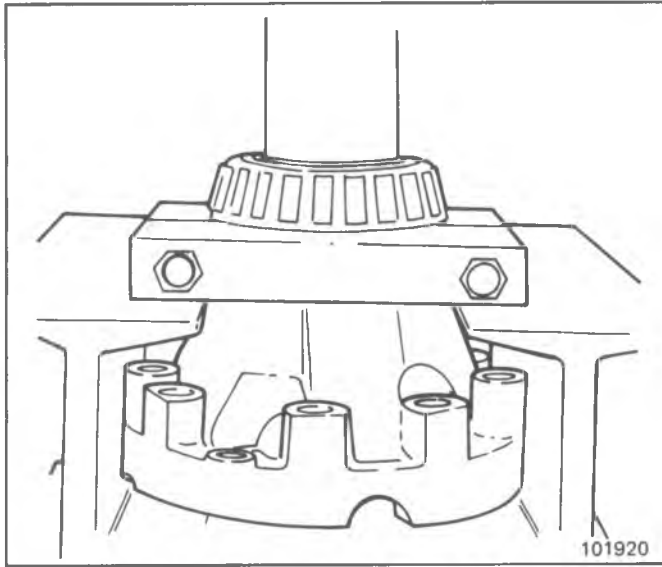

Fig. 4B5-10 – Removing Differential Bearing

**NOTICE:** The use of a pinch bar will damage the shims. Driving pinion from inner end with a drift will damage the bearing lock ring groove.

6. Wire shim pack together to facilitate adjustment on reassembling.

**Disassemble Pinion and Cage Assembly**

1. Tap shaft out of cage with soft mallet or press shaft from cage.
2. Remove outer bearing from cage.
3. Remove spacer or spacer combination from pinion shaft.
4. Remove inner bearing using a press or puller.
5. If necessary to replace rear straddle bearing, remove with suitable puller.
6. Remove oil seal assembly from bearing cover.

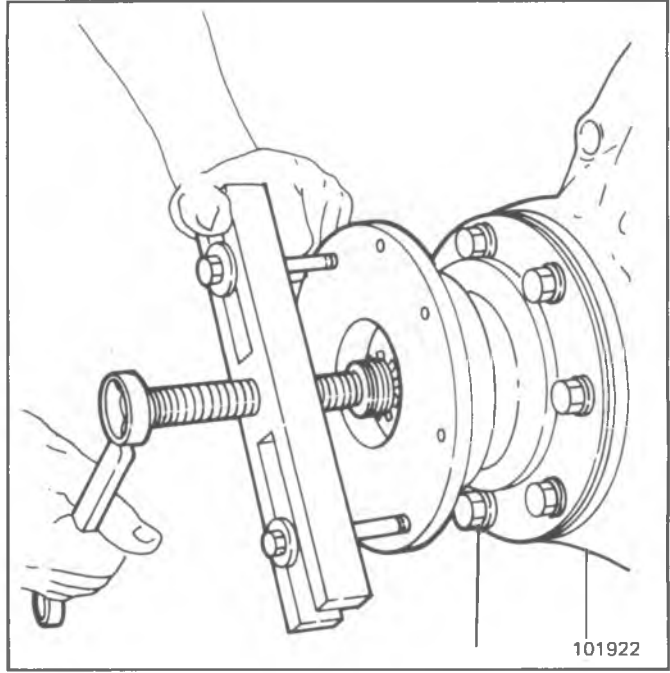

Fig. 4B5-12--Removing Flange

**CLEANING AND INSPECTION**

**Cleaning**

Steam cleaning assembled drive units after they have been removed from the housing is not recommended. When this method of cleaning is used, water is trapped in the cored passage of the castings and in the close clearances between parts as well as on the parts. This can lead to corrosion (rust) of critical parts of the assembly and the possibility of circulating rust particles in the lubricant. Premature failure of bearings, gears and other parts can be caused by this practice. Assembled drive units cannot be properly cleaned by steam cleaning, dipping or slushing. Complete drive unit disassembly is a necessary requisite to thorough cleaning.

Completely assembled axles, torque dividers and transfer cases may be steam cleaned on the outside only, to

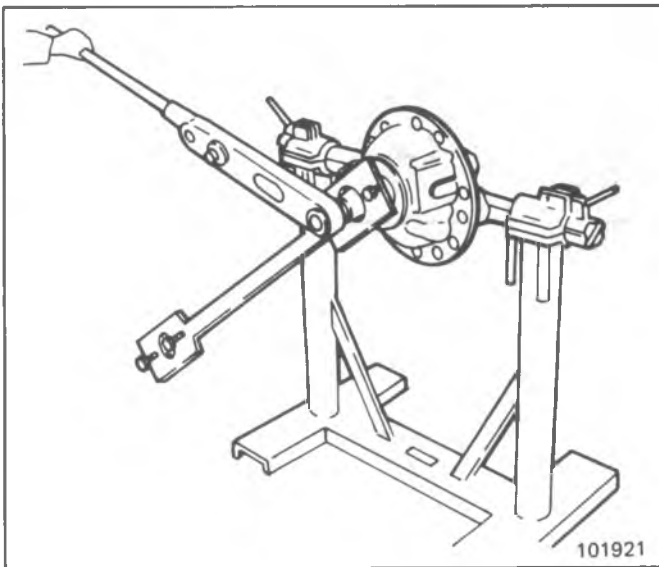

Fig. 4B5-11--Removing Pinion and Cage

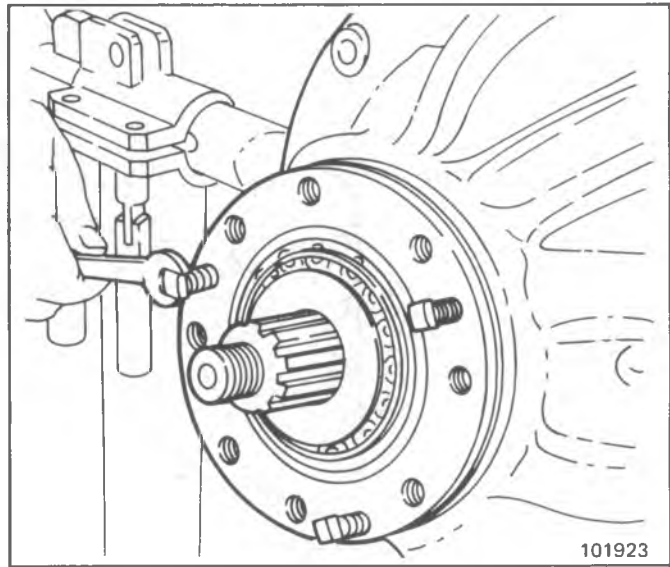

Fig. 4B5-13--Removing Bearing Cage

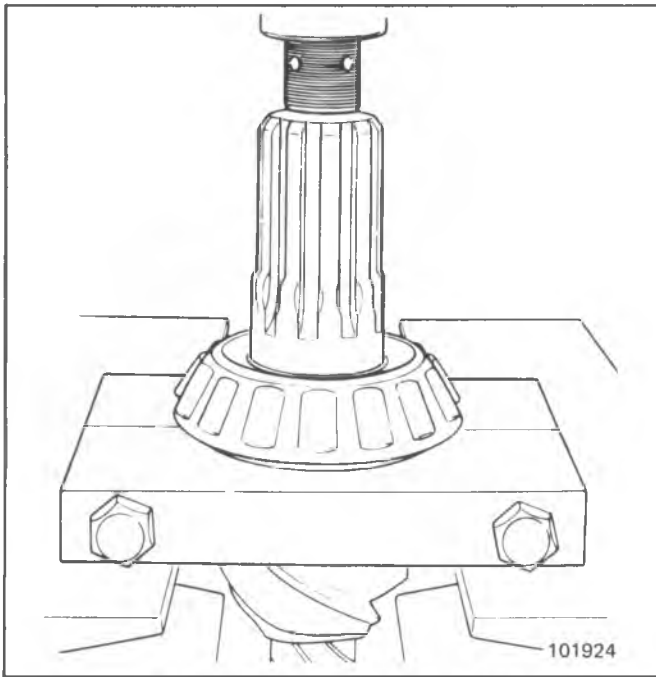

Fig. 4B5-14--Removing Inner Bearing

facilitate initial removal and disassembly, providing all openings are closed. Breathers, vented shift units, and all other openings should be tightly covered or closed to prevent the possibility of water entering the assembly.

Parts should be thoroughly dried immediately after cleaning. Use soft, clean, lintless absorbent paper towels or wiping rags free of abrasive material, such as lapping compound, metal filings or contaminated oil. Bearings should never be dried by spinning with compressed air.

### Inspection

It is impossible to over stress the importance of careful and thorough inspection of drive unit parts prior to reassembly. Thorough visual inspection for indications of wear or stress, and the replacement of such parts as are necessary will eliminate costly and avoidable drive unit failure.

Inspect all bearings, cups and cones, including those not removed from parts of the drive unit, and replace if rollers or cups are worn, pitted or damaged in any way. Remove parts needing replacement with a suitable puller or in a press with sieves. Avoid the use of drifts and hammers. They may easily mutilate or distort component parts.

Refer to Section 4B for bearing diagnosis.

### REASSEMBLY

Where silicone RTV gasket material is used, Dow Silastic No. RTV-732 Black and General Electric No. RTV-1473 Black (or equivalent) should be used.

**NOTICE:** Failure to use appropriate gasket material will cause axle to leak.

Removal of all gaskets including silicone RTV is accomplished by peeling or scraping the used gasket off both mating surfaces. Application of silicone RTV gasket material is as follows:

1. Remove dirt, grease or moisture from both mating surfaces.

2. Dry both surfaces.
3. Apply thin bead, approximately 1/8" diameter completely around one mating surface and all fastener holes to assure complete sealing and prevent leakage.

**CAUTION:** Minor concentrations of acetic acid vapor may be produced during application. Adequate ventilation should be provided when silicone RTV is applied in confined areas.

**Further, eye contact with these silicone RTV gasket materials may cause irritation; if eye contact takes place, flush eyes with water for 15 minutes and have eyes examined by a doctor.**

4. Assemble the components immediately to permit silicone RTV gasket material to spread evenly.

When rebuilding any assembly, always use torque values on fasteners as specified.

### Gear Set Identification

If a new gear set (drive pinion and ring gear) is being installed into the carrier, refer to the following gear set information before starting reassembly. However, if the original gear set is to be installed, start with Pinion and Case Reassembly.

The following information is marked on current drive pinion and gear sets, and will be used for identifying, matching and adjusting procedures. The items listed are keyed to illustration (Fig. 4B5-15).

1. Part Number.
2. Tooth Combination Number.

The Part Number and Tooth Combination Number are found on the shank or threaded end of all pinions. On the ring gears, the numbers are normally found on the front face of the gear. However, as an option, they may be located at the gear O.D.

For any given pinion and gear set, the ring gear always has an even part number (i.e. 36786) and the matched pinion has the odd number (i.e. 36787).

The tooth combination number (i.e. 5-37) indicates the gear set has a 5 tooth pinion and a 37-tooth ring gear, the equivalent of a 7.4 to 1 gear ratio.

Always refer to the Part Number and Tooth Combination Number before starting the reassembly. Check to be certain the pinion and gear match.

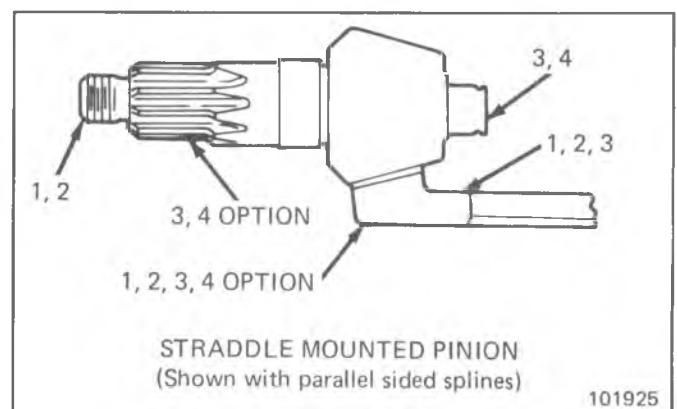

Fig. 4B5-15--Gear Set Identification

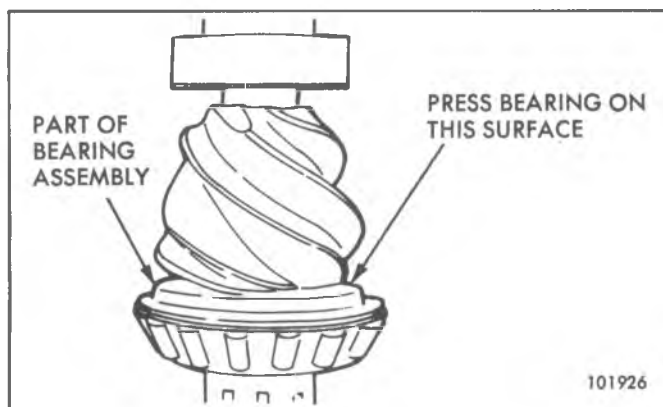

Fig. 4B5-16--Installing Bearings

### 3. Gear Set Matching Numbers

All drive pinion and gear sets are manufactured and sold only in matched sets. Both pieces of the set have a matching number such as "M29" or any combination of a letter and number.

On most pinions, the number is usually marked on the head end. However, on pinions with parallel-sided splines, the number may be marked on the top flat or one of the splines.

On the ring gear, the number is usually found on the front face of the gear, although sometimes it may be on the gear O.D.

A gear and pinion which do not have the same matching numbers must not be run together. Therefore, if either a pinion or a ring gear should require replacement, both must be replaced in a matched set.

### 4. Pinion Cone Variation Number

Each pinion has a Pinion Cone (P.C.) Variation Number which indicates variations (in thousandths of an inch) from the nominal mounting distance. This Pinion Cone Variation Number is necessary because pinion and gear sets for a specific series of axles cannot be manufactured exactly alike, and there may be slight differences in the Mounting Distance of the individual gear sets. This P.C. Variation Number must be used to modify the Nominal Pinion Gaging Dimension when using a pinion setting gage or when calculating pinion cage shim pack thickness.

The Pinion Cone Variation Number (i.e. P.C. 3 or P.C. -5) is normally found on the pinion head end; however, it may sometimes be located on a spline of a pinion with the larger parallel-sided-type splines or on the ring gear O.D.

**The nominal pinion mounting distance is 6.125 inch (155.58mm).**

**The pinion backlash setting is .005" - .015" (.13 - .39mm).**

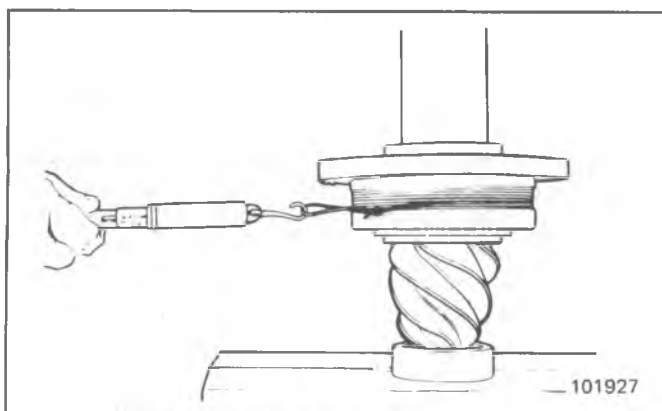

Fig. 4B5-17--Preload Torque

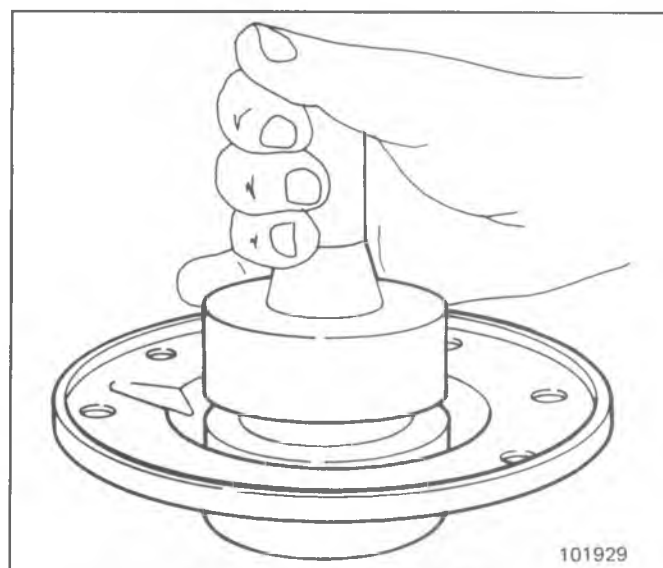

Fig. 4B5-19--Installing Seal

## PINION AND CAGE

### Reassembly

1. If new cups are to be installed, press firmly against pinion bearing cage shoulders (Fig. 4B5-16).
2. Lubricate bearings and cups with the recommended axle lubricant.
3. Press rear thrust and radial bearings firmly against the pinion shoulders with a suitable sleeve that will bear only on bearing inner race.
4. Install radial bearing lock ring and squeeze ring into pinion shaft groove with pliers.
5. Insert pinion and bearing assembly in pinion cage and position spacer or spacer combination over pinion shaft.
6. Press front bearing firmly against spacer.
7. Rotate cage several revolutions to assure normal bearing contact.

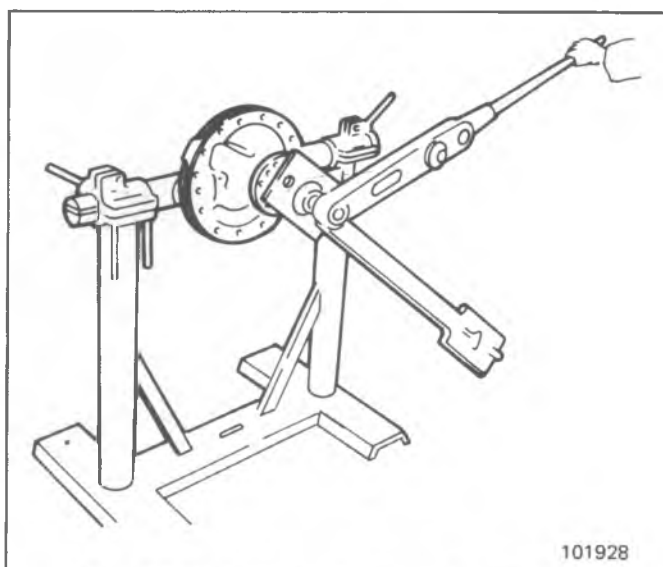

Fig. 4B5-18--Holding and Torquing Pinion Flange

8. While in press under pressure, check bearing preload torque. Wrap soft wire around cage and pull on horizontal line with pound scale (Fig. 4B5-17).

**Use rotating torque, not starting torque.**

If a press is not available, the pinion nut may be tightened to the correct torque and preload checked.

The correct pressures and torque for checking pinion bearing preload are shown in specifications.

If rotating torque is not within 5 to 15 pound inches, use thinner spacer to increase or thicker spacer to decrease preload.

**Example: Assuming pinion cage diameter to be 6 inches, the radius would be 3 inches and with 5 pounds pull would equal 15 pound inches preload torque.**

9. Press flange or yoke against forward bearing and install washer and pinion shaft nut.
10. Place pinion and cage assembly over carrier studs, hold flange and tighten pinion shaft nut to the correct torque. The flange must be held with a suitable tool or fixture to tighten nut (Fig. 4B5-18).
11. Recheck pinion bearing preload torque. If rotating torque is not within 5 to 15 pound inches, repeat the foregoing procedure.
12. Hold flange and remove pinion shaft nut and flange.
13. Lubricate pinion shaft oil seal and cover outer edge of seal body with a non-hardening sealing compound. Press seal against cover shoulder with seal driver (Fig. 4B5-19).
14. Install new gasket and bearing cover.
15. Press flange against forward bearing and install washer and pinion shaft nut (Fig. 4B5-20).
16. Tighten nut to the correct torque value.

### Selecting Pinion Cage Shim Pack Thickness

A means of accurately installing a new pinion and cage assembly into the carrier is to mathematically calculate the proper pinion cage shim pack thickness.

The following are the procedures to use:

1. Measure the thickness of the original shim pack used with the gear set being replaced. Use a micrometer or vernier gage. Record this measurement for future use.
2. Observe the "PC" or variation number on the original pinion being replaced. If this number is a plus ( + ) value, subtract it from the original shim pack measurement taken in item "1". If the variation number is a minus ( - ) value, add it to the measurement from item "1". Make a note of this value.

**The value calculated in item "2" will establish a "standard shim pack thickness", without a variation. This value will be used in calculating the shim pack thickness used with a new pinion and gear set.**

3. Observe the "PC" or variation number on the new pinion, (locations of the "PC" number are shown above). Add or subtract this number as indicated by the variation sign ( + add or - subtract) from the calculated "standard shim pack thickness" determined in item "2".

The resulting answer indicates the thickness (in thousandths) of the new shim pack to be used. Refer to the following examples which cover all the possible combinations of or - original and new "PC" variations.

After calculating the shim pack thickness, assemble the new pinion and cage assembly with the correct shim pack into the carrier as follows:

Remember all drive pinion and gear sets are manufactured and sold only in matching sets. Therefore, if either a pinion or a ring gear should require replacement, both must be replaced in a matching set.

### Pinion and Cage Assembly

#### Installation

1. Position the correct shim pack between the pinion cage and carrier.  
**Use a minimum of three (3) shims per pack. If the pack is made up from various thicknesses of shims, locate thinnest shims on both sides of the pack for maximum sealing ability.**
2. Install the pinion and cage assembly with shims into carrier and tap into position with soft mallet.
3. Install pinion cage capscrews. Tighten capscrews to the correct torque.
4. After the differential and gear assembly is installed into carrier, make a gear tooth contact check (Refer to Section 4B).

### Differential and Gear

#### Assembly

**NOTICE:** The ring gear must be heated before assembling onto the case half, otherwise damage to the case half will result.

Proper service replacement of the differential ring gear onto the differential case half is necessary for correct gear adjustment and longer drive unit service life.

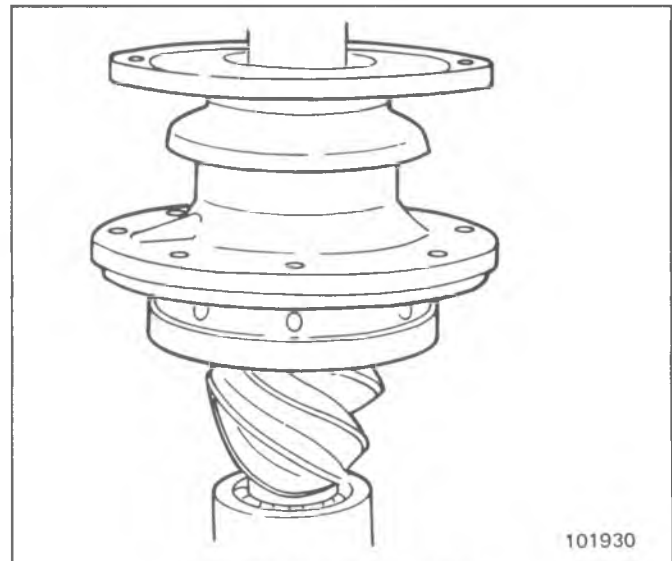

Fig. 4B5-20--Installing Flange



For correct installation, heat the ring gear in water to approximately 160°-180° for about ten minutes before assembly. This will allow an easier fit of the gear over the differential case pilot, without the use of a press, and without damaging the case and ring gear mating surfaces.

**NOTICE:** The gear should not be pressed or driven on the case, as this would cause excessive metal particles to lodge between the gear and case, thus resulting in gear runout. Proper installation should, therefore, incorporate preheating the gear as described above to assure correct interference fit and to eliminate metal pick-up.

Differential case and ring gear bolts should be used for service replacement of rivets if required. Replacement bolt kits are available through service. Refer to specifications for service bolt instructions and torque.

**EXAMPLES OF CALCULATION:**

**EXAMPLE NO. 1**

|                            |   |       |
|----------------------------|---|-------|
| Original Pack Thickness    | - | .030" |
| Original Variation (PC +2) |   | .002  |
| Standard Pack Thickness    |   | .028" |
| New Variation (PC +5)      | + | .005  |
| New Pack Thickness         |   | .033" |

**EXAMPLE NO. 2**

|                            |   |       |
|----------------------------|---|-------|
| Original Pack Thickness    | + | .030" |
| Original Variation (PC +2) |   | .002  |
| Standard Pack Thickness    |   | .032" |
| New Variation (PC +5)      | + | .005  |
| New Pack Thickness         |   | .037" |

**EXAMPLE NO. 3**

|                            |   |       |
|----------------------------|---|-------|
| Original Pack Thickness    | - | .030" |
| Original Variation (PC +2) |   | .002  |
| Standard Pack Thickness    |   | .028" |
| New Variation (PC -5)      | - | .005  |
| New Pack Thickness         |   | .023" |

**EXAMPLE NO. 4**

|                            |   |       |
|----------------------------|---|-------|
| Original Pack Thickness    | + | .030" |
| Original Variation (PC -2) |   | .002  |
| Standard Pack Thickness    |   | .032" |
| New Variation (PC-5)       | - | .005  |
| New Pack Thickness         |   | .027" |

**Differential Pinion and Side Gear (Fig. 4B5-21)**

**Assembly**

1. Position thrust washer and side gear in ring gear and case half assembly.
2. Place spider with pinions and thrust washers in position.
3. Install component side gear and thrust washer.
4. Align mating marks, position component case half and draw assembly together with four bolts or capscrews equally spaced (Fig. 4B5-22).
5. Check assembly for free rotation of differential gears and correct if necessary.
6. Install remaining bolts and capscrews, tighten to the correct torque.
7. If bearings are to be replaced, press squarely and firmly on differential case halves.

**Rolling Resistance Check of Differential Nest**

1. Place differential and ring gear assembly in a vise.  
Use soft metal covers over vise jaw to protect ring gear.

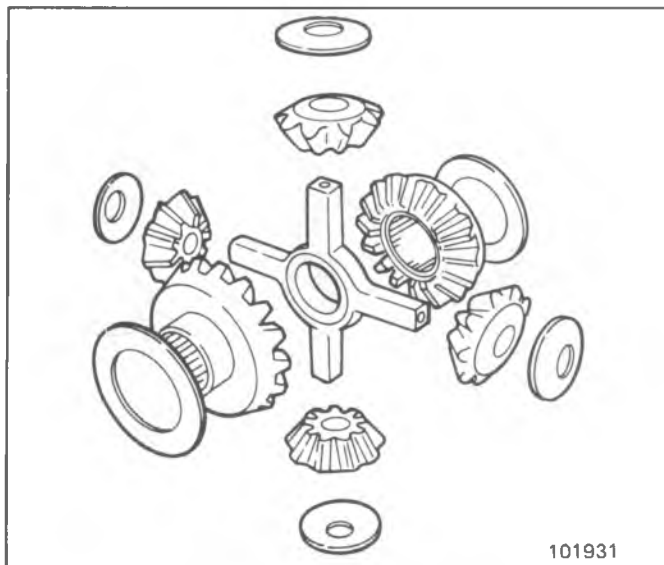

Fig. 4B5-21--Pinion and Side Gears

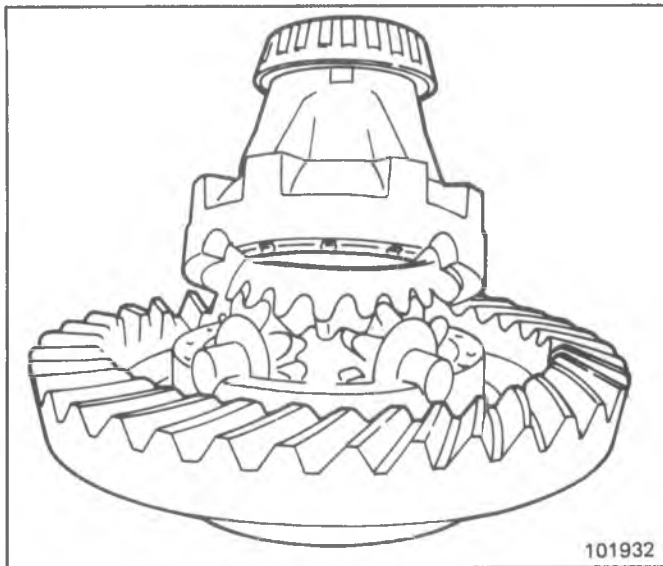

Fig. 4B5-22--Align Marks

2. Insert checking tool (made from splined axle shaft end) into differential nest. Allow splines of tool to engage with spline of one side gear only (Fig. 4B5-23).
3. Using a suitable socket and torque wrench, rotate differential nest while observing scale on torque wrench (Fig. 4B5-24).

Correct rolling resistance of differential assembly is 50 lb. ft. torque maximum applied to one side gear. This applies to all differential assemblies.

A suitable checking tool can be made by cutting an axle shaft to an appropriate length and welding a nut on the end to accept a wrench socket (Fig. 4B5-25).

### Install Bearing Cups

1. Temporarily install the bearing cups, threaded adjusting rings where employed and bearing caps. Tighten the capscrews to the proper torque.
2. The bearing cups must be of a hand push fit in the bores, otherwise the bores must be reworked with a

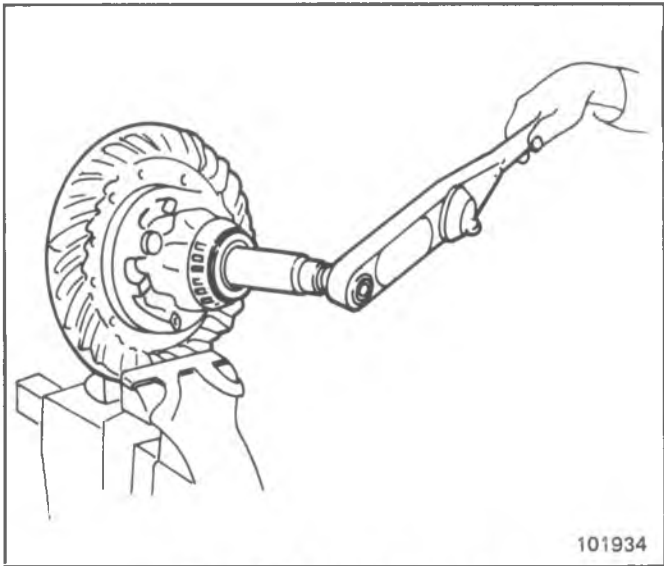

Fig. 4B5-24--Checking Torque

scraper or some emery cloth until a hand push fit is obtained. Use a blued bearing cup as a gage and check the fits as work progresses. Once the cups fit properly, remove the bearing caps (Fig. 4B5-26).

### Installing Differential and Gear

1. After checking related parts, coat the differential bearing cones and cups with specified rear axle lubricant.
2. Place the bearing cups over the assembled differential bearing cones, then position the differential assembly in the carrier.
3. Insert bearing adjusting nuts and turn hand-tight against bearing cups.
4. Install bearing caps in the correct location as marked and tap lightly into position.

If bearing caps do not position properly, adjusting nuts may be cross threaded. Remove caps and reposition the adjusting nuts (Fig. 4B5-27). Forcing caps into position will result in irreparable damage to the carrier housing or bearing caps.

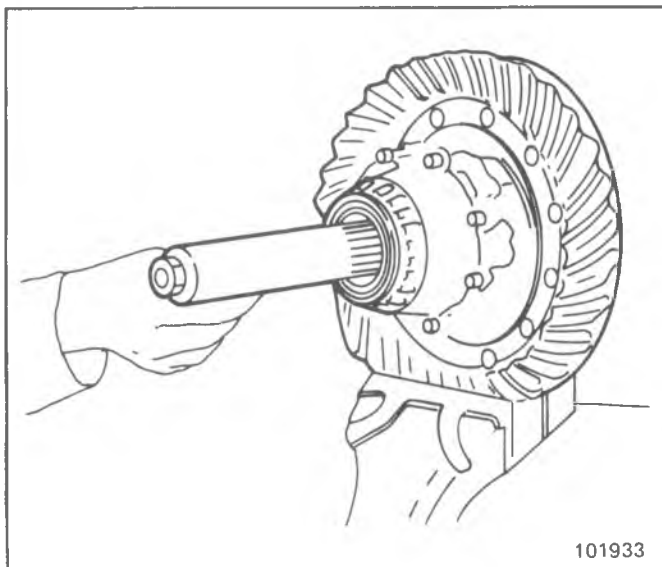

Fig. 4B5-23--Installing Tool

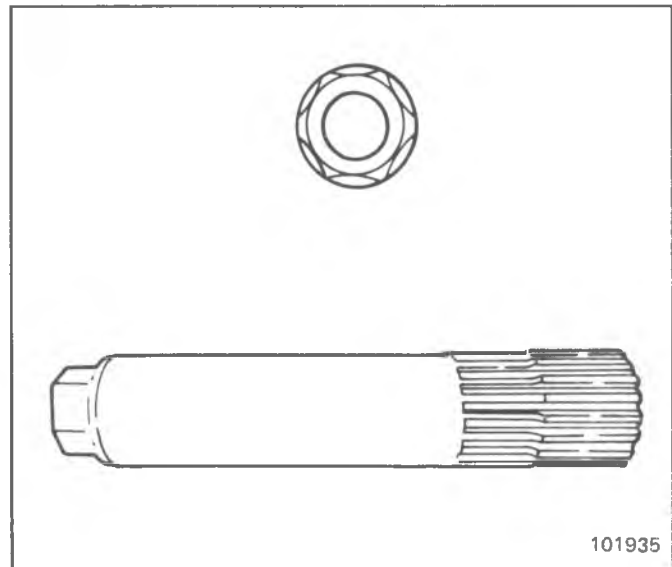

Fig. 4B5-25--Checking Tool

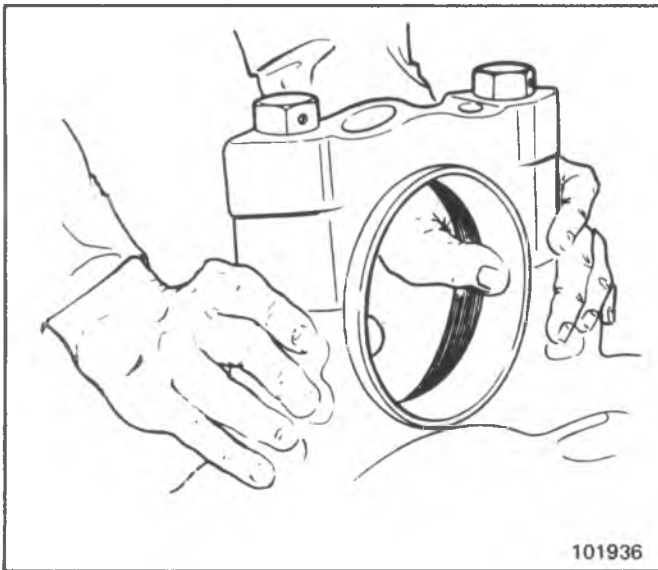

Fig. 4B5-26--Fitting Bearing Cups

5. Install flat washers and capscrews. Tighten stud nuts or capscrews to correct torque.

### Adjusting Differential Bearing Preload

1. Using dial indicator at backface of gear, loosen the bearing adjusting nut on the side opposite gear only sufficient to notice end play on the indicator (Fig. 4B5-28).
2. Tighten the same adjusting nut only sufficient to obtain .000 end play.
3. Check gear for runout. If runout exceeds .008", remove differential and check for cause.
4. Tighten adjusting nuts one notch each from .000 end play to preload differential bearings.

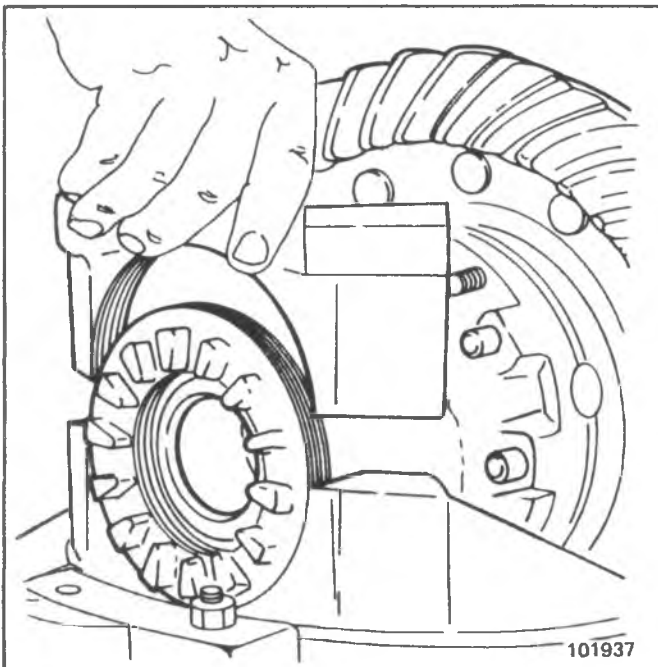

Fig. 4B5-27--Installing Bearing Caps

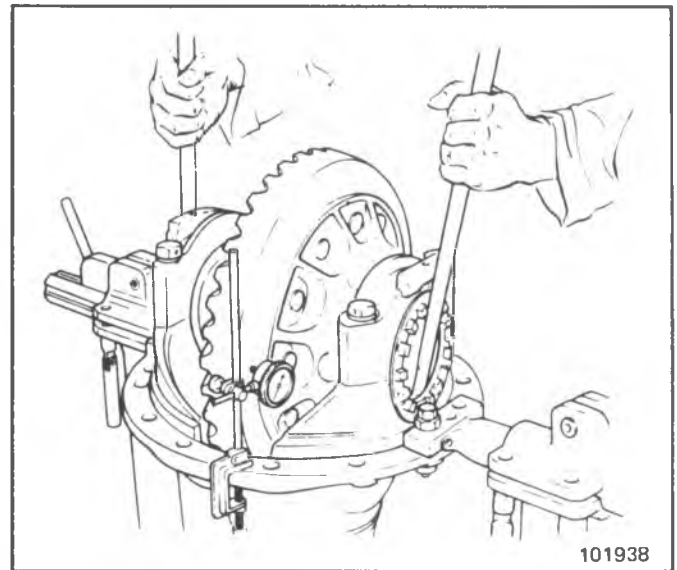

Fig. 4B5-28--Adjusting Bearing Preload

### Checking Backlash

If the drive gear is not going to be replaced, use the established backlash recorded before disassembly. For new gears, the new backlash should be initially set at .010". Adjust backlash by moving the gear only. This is done by backing off one adjusting ring and advancing the opposite ring the same amount (Fig. 4B5-29). Install cotter keys.

### Installing Thrust Screw

1. Remove carrier from stand and position with back face of hypoid or spiral bevel gear upward.
2. Remove adjusting screw and lock nut.
3. Install thrust screw and lock nut and tighten thrust screw sufficient to locate thrust block firmly against back face of hypoid gear.
4. To secure the correct adjustment of .010" - .015" clearance, loosen adjusting screw (or thrust screw) 1/4 turn and lock securely with nut (Fig. 4B5-30).
5. Recheck to assure minimum clearance of .010" during full rotation of bevel gear.

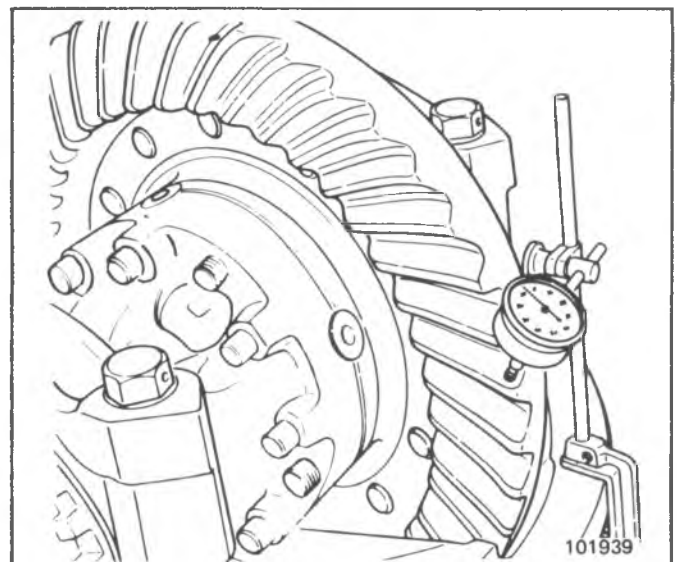

Fig. 4B5-29--Checking Backlash

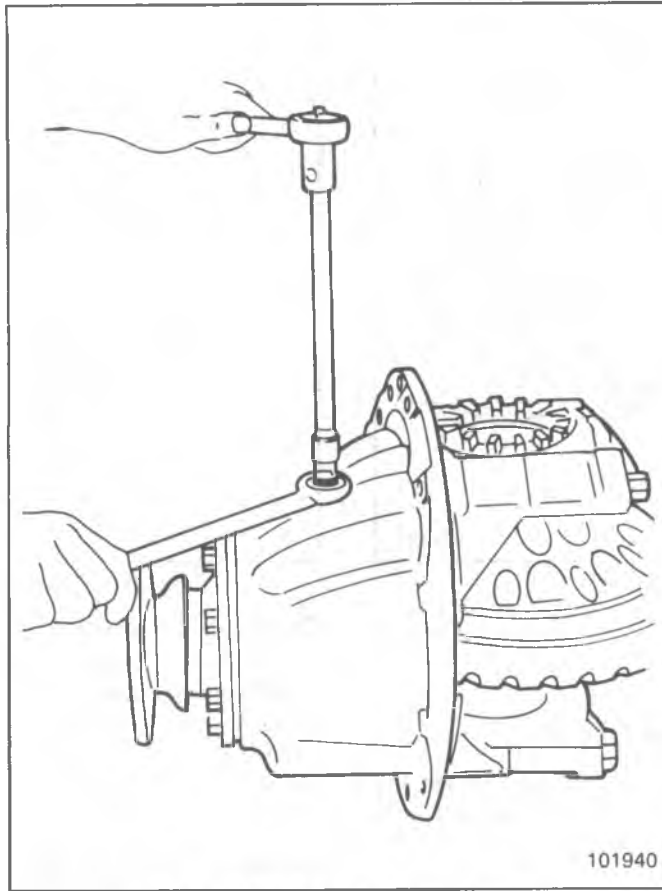
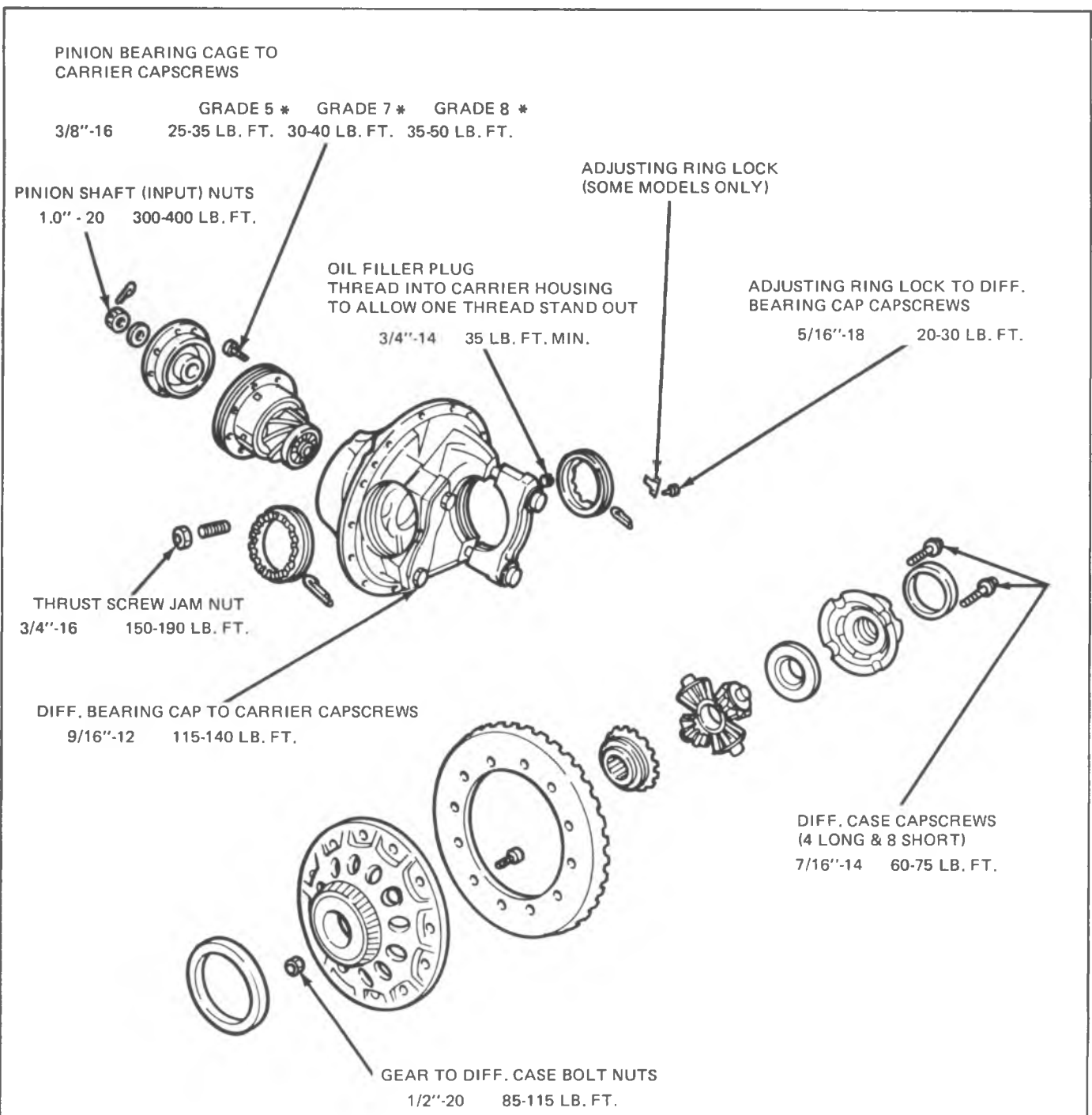

Fig. 4B5-30--Adjusting Thrust Screw



FOR ALL FASTENERS

- ALL TORQUES GIVEN APPLY TO PARTS LIGHTLY COATED WITH RUST PREVENTATIVE TYPE OIL
- FOR DRY PARTS - INCREASE TORQUES 10%
- FOR PARTS HEAVILY COATED WITH OIL - DECREASE TORQUES 10%

\* GRADE IDENTIFICATION FOR CAPSCREWS (HEAD MARKINGS)

- GRADE 5
- GRADE 7
- GRADE 8



# EATON LOCKING DIFFERENTIAL

## CONTENTS

|                                       |    |
|---------------------------------------|----|
| General Description.....              | 1  |
| Checking Locking Diff. Operation..... | 1  |
| Diagnosis.....                        | 2  |
| 8-1/2" Ring Gear.....                 | 4  |
| 8-7/8" Ring Gear.....                 | 7  |
| 9-1/2" Ring Gear.....                 | 10 |
| 10-1/2" Ring Gear.....                | 14 |

## GENERAL DESCRIPTION

### EATON LOCKING DIFFERENTIAL

The Locking Rear Differential allows for normal differential function, as noted in the Standard Rear Axle Section. Typical construction are shown in Figs. 2 and 3. In addition, the Locking Rear Differential incorporates multi-disc clutch packs and a speed sensitive engagement mechanism, which locks both wheels together if either wheel should spin excessively during slow vehicle operation.

Under light loads, the clutch plates alone tend to lock axle shafts to the differential case, and therefore, each other. This is due primarily to the gear separating load developed on the RH (LH on 10-1/2" model) clutch pack. This induced clutch torque capacity resists motion between the side gear and the rear axle differential case. The axle shaft torques developed when turning a corner will overcome this capacity and allow differentiation. Also, heavier throttle application will cause differentiation, but this initiates the full-lock feature of the unit.

Full locking is accomplished through the use of flyweight governor mechanism, cam system, and multi-disc clutch packs. The flyweights on the governor mechanism move outward to engage a latching bracket whenever the wheel-to-wheel speed varies by approximately 100 rpm or more. This action retards a cam which, in turn, compresses the multi-disc clutch packs locking both side gears to the case. The 100 rpm wheel-to-wheel speed allows for cornering without differential lock-up.

At vehicle speeds above approximately 20 mph (32 km/h), the latching bracket overcomes a spring preload and swings away from the flyweights. At this vehicle speed or greater, the differential will not lock as the added traction is generally not required.

All rear axle parts of vehicles equipped with the Locking Rear Axle are interchangeable with those equipped with the conventional rear axle, except for the case assembly.

### CHECKING LOCKING DIFFERENTIAL OPERATION

1. Place the vehicle on a frame-contact hoist, allowing free rotation of the rear wheels.
  2. Raise hoist until wheels clear floor. Holding one wheel stationary, slowly rotate other wheel approximately 1/2 revolution per second, in both the forward and reverse directions. Wheel should rotate freely and opposite directions. If both wheels attempt to turn together, the differential is locking prematurely and is defective.
  3. Raise hoist to maximum height with one person in vehicle.
  4. Start engine making sure that carburetor is set at a slow idle speed.
  5. With automatic transmission, apply brakes, then place transmission in drive. With manual transmission, depress clutch and place transmission in first gear.
  6. An assistant should then lock one rear wheel by pulling one parking brake cable from under the vehicle.
  7. With engine at low idle, slowly release brakes, or slowly engage clutch, as required.
  8. Locked rear wheel will remain stationary and free wheel will begin turning. It is important that brakes or clutch be released slowly enough to start the free wheel turning and allow the free wheel to gradually increase in speed. As speed of the free wheel is increased, the differential will lock causing the rotating wheel to stop or both wheels to run at the same speed. The engine may stall if equipped with a manual transmission. It may be necessary to accelerate engine until approximately 10 mph is indicated on vehicle speedometer to cause differential lock.. If indicated speed can be increased beyond 20 mph (32 km/h) without causing differential lock, the unit is not functioning properly.
- NOTICE:** Rapid release of brakes or clutch, or rapid acceleration of engine will invalidate test.
9. Lock opposite rear wheel and repeat procedure. The following chart provides guidelines for diagnosis and repair of differential complaints.

## DIAGNOSIS

Improper differential operation is generally indicated by non-uniform clutch slippage. Sometimes this produces a chatter or whirring sound. However, these sounds are not always indicative of failure as they could be produced from a lack of proper lubrication. For example, under certain conditions where one wheel is on a very slippery surface and the other on dry pavement, wheel spin can occur if over acceleration is attempted. Continued spinning may cause audible noise, such as a whirring sound due to the clutches lacking sufficient lubricant. This does not necessarily indicate failure of the unit.

During regular operation (straight ahead driving) when both wheels rotate at equal speeds, there is an

approximately equal driving force delivered to each wheel. When cornering, the inside wheel delivers extra driving force causing slippage in both clutch packs. Consequently, the operational life of the unit is dependent upon equal rotation of both wheels during straight ahead operation. If wheel rotation for both rear wheels is not equal during straight ahead operation, the unit will constantly be functioning as if the vehicle were cornering. This will impose constant slippage on the clutch packs and will eventually lead to abnormal wear on the clutch pack. Therefore, it is important that there be no excessive differences in the rear wheel tire sizes, air pressures, or tire wear patterns.



**LOCKING DIFFERENTIAL DIAGNOSIS**

| Complaint          | Possible Cause  | Correction  |
|--------------------|---|---|
| Does not lock.     | A. Little or no spring preload on the latching bracket      | A. Replace governor assembly and latching bracket.  |
|                    | B. Flyweights on governor assembly stuck closed.            | B. Replace governor assembly and latching bracket.  |
|                    | C. Broken drive teeth on governor and/or cam gear assembly. | C. Replace cam plate, governor assembly and latching bracket.   |
|                    | D. Broken clutch plates                                     | D. Replace clutch plates and wave spring.   |
| Locks in turns.    | A. Governor assembly tight in case.                         | A. Free up governor assembly.   |
|                    | B. Broken or weak governor flyweight spring.                | B. Replace governor assembly and latching bracket.  |
|                    | C. Flyweight in governor assembly stuck open.               | C. Replace governor assembly and latching bracket.  |
|                    | D. Broken cam plate and/or governor drive teeth.            | D. Replace cam plate, governor assembly and latching bracket.   |
| Chatters in turns. | A. Lubricant contaminated.                                  | A. Drain lube hot. Wipe carrier clean. Refill with lube specified in Maintenance and Lubrication Section. |
|                    | B. Clutch Plates deteriorated.                              | B. Replace clutch plates.   |

Noisy.

**NOTE:** In addition to normal axle noise (see Rear Axle Diagnosis Section), the locking differential exhibits some clutch noise upon engagement and disengagement.

- |                               |  |
|-------------------------------|--|
| A. Broken clutch plates.      | A. Replace clutch plates.  |
| B. Broken thrust block.       | B. Replace thrust block. * Check closely for other damage. Replace entire unit if case is damaged. |
| C. Broken differential gears. | C. Replace gears. ** Check closely for other damage. Replace entire unit if case is damaged.       |

\* Thrust block must be replaced with block of identical thickness.

\*\* If side gears or cam gear is replaced, proper measurement and replacement procedures must be followed. Disregard for such procedure as: May disturb critical clearances, and could result in differential performance complaints.

Fig. 1-Diagnosis Chart

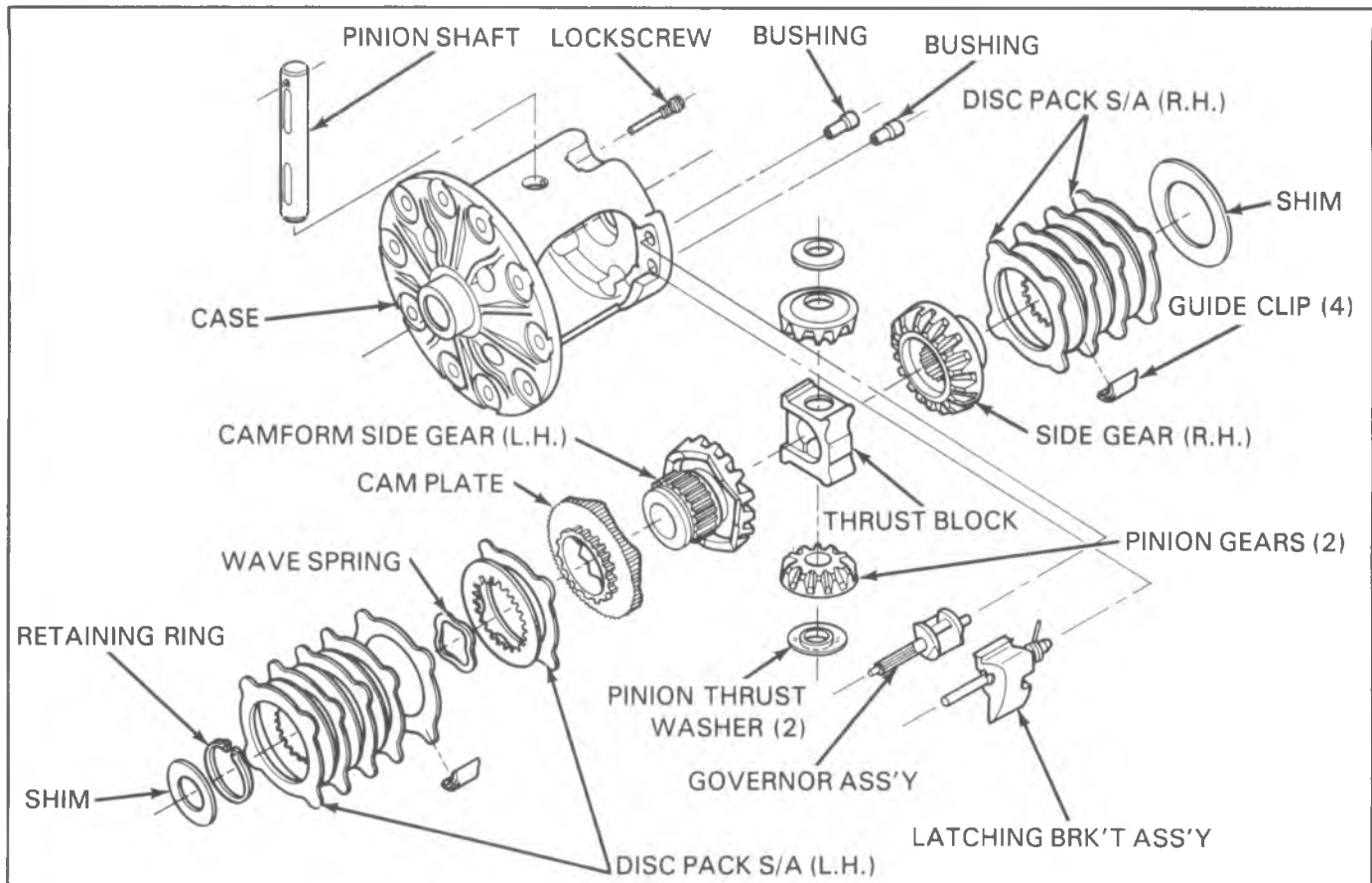

Fig. 2--8-1/2" Ring Gear

## UNIT REPAIR

### 8-1/2" RING GEAR

Due to critical internal clearance dimensions, the differential case cannot be serviced separately. If any case damage is found the entire differential must be replaced.

Internal clearances are such that shims, thrust block, or gears should not be replaced unnecessarily even if slight wear indications are present. If shim, thrust block, or gears must be replaced due to damage, correct measurement and replacement procedures must be followed. Failure to do so may disturb critical clearances and could result in differential complaints.

Internal components can be inspected through the windows of the differential housing.

If the governor assembly and latching bracket are the only items to be replaced, proceed only through step No. 2 of the disassembly procedure. To install new governor and latching bracket, begin at step No. 6 of the reassembly procedure.

#### CASE - 8.50 R/G

##### Disassembly

1. Note position of governor and latching bracket assembly, Figure 3. Remove ring gear and side bearings following procedures established for the standard differential.
2. Using bushing puller tool No. J-26252, remove governor assembly and latching bracket by pulling the

retaining bushings as shown in Figure 4. Pull the latching bracket spring out of the way while pulling the governor assembly bushing to prevent damage.

3. Remove lock screw and pinion shaft, and roll out differential pinion gears and pinion thrust washers.
4. Remove thrust block.
5. Remove RH disc pack assembly and shim.
6. Remove cam gear, disc pack assembly and shim.

##### Inspection

1. Clean all parts with solvent. Inspect all bearings for chipping or evidence of excessive wear. Replace parts as needed.
2. Inspect all differential components for excessive wear and breakage. Replace parts as needed. The following are serviceable components for this differential:
  - Governor assembly and latching bracket with spring
  - Cam plate
  - Clutch disc pack with guide clips (Both LH and RH)
  - Pinion cross-shaft
  - Pinion gears, side gear, cam gear.
  - Pinion thrust washers
  - Thrust block (8 sizes)
  - Retaining ring

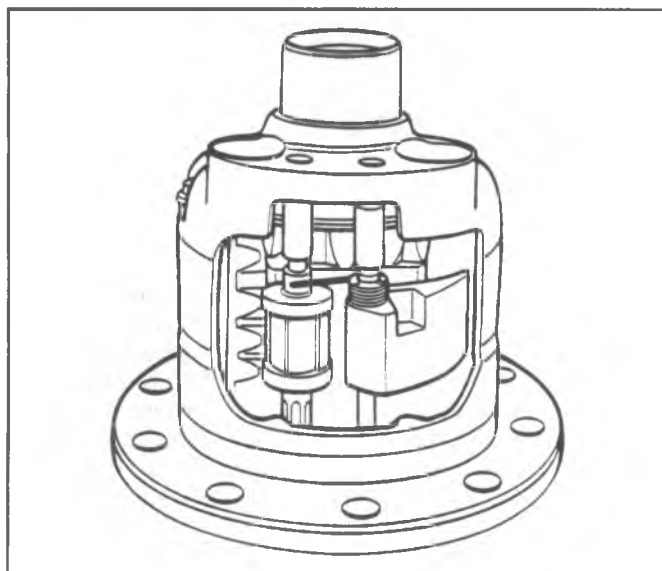

Fig. 3--Governor and Latching Bracket

- Flange end shim (8 sizes), Bell end shim (8 sizes)
- Lock Screw
- Governor Bushing
- Disc Guide Clips (Both LH and RH)

If thrust block or flange end shim only must be replaced, the original pieces must be carefully measured for thickness and replaced with a piece of the same size.

### CAM/CLUTCH SERVICE

#### Disassembly (Flange End)

If cam plate or clutch discs must be replaced, the cam gear sub-assembly must be serviced as follows:

1. Remove retaining ring (use .06 external snap-ring plier) (Fig. 5).
2. Remove discs and camplate. Keep all components in the proper order.

#### Reassembly - Flange End

Replace cam plate and wave spring or clutch discs as necessary and reassemble as follows: (See Fig.2).

1. Place gear on bench with hub end up.
2. Assemble cam plate with cam form down to mate with cam form on gear.
3. Assemble onto cam plate: (2) eared discs, (1) splined disc, and (1) wave spring alternately as shown.
4. Assemble on to gear hub (2) splined discs and (3) eared discs alternately as shown. Begin and end with an eared disc.
5. Install retaining Ring.

### CLUTCH PACK (R.H.)

#### Disassembly

1. Remove disc pack and shim from side gear. Keep discs in order.

#### Reassembly

1. Replace disc and/or clips, as required.
2. Reassemble material on gear hub (two splined discs and three eared discs) alternately as shown in Fig. 2. Maintain original sequence, if new discs are not used. Reinstall original shim, or a new with original thickness.

**NOTICE:** If gear hubs are scored, rough or show abnormal wear, check condition of bores in case. If they are damaged or oversize, the entire unit must be replaced.

### DIFFERENTIAL THRUST BLOCK AND GEAR

#### Pinion Gears

#### Replacement

If it is necessary to replace the pinion gears due to pitting of the teeth, scoring of the pinion shaft bearing surface, or breakage, it will be necessary to disassemble the unit through Step 3 of case disassembly. Install new pinion gears and pinion thrust washers and reassemble unit as described in Steps 4 through 9 of case reassembly.

**NOTICE:** If camgear, side gear, or pinion gears are broken, check for other damage and replace parts as needed. If case is damaged, the entire unit must be replaced.

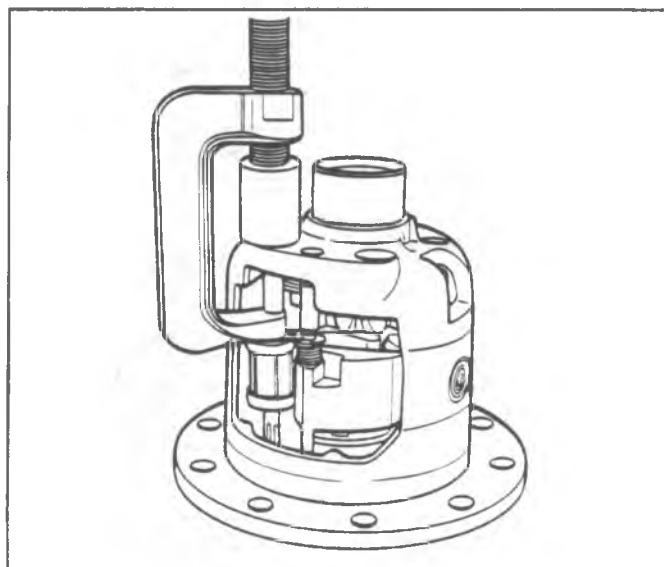

Fig. 4--Bearing Puller J-26252

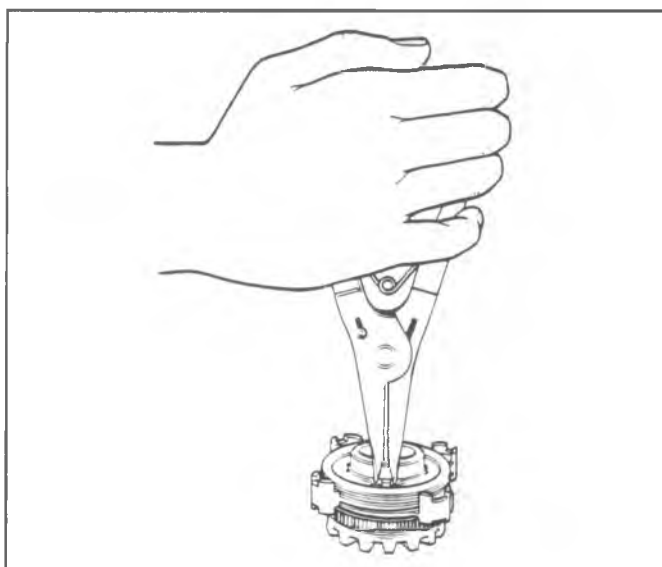

Fig. 5--Retaining Ring

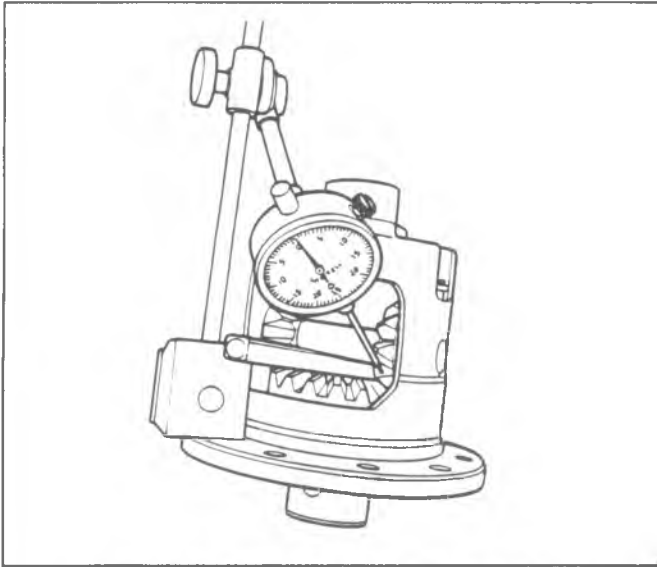

Fig. 6--Camgear to Pinion Gear Backlash

replaced.

### Camgear (L.H. Side Gear)

#### Replacement

If it is necessary to replace the camgear due to pitting of the teeth, scoring of the hub, or breakage, it will be necessary to disassemble the unit completely as described in Steps 1 through 6 of case disassembly and in Steps 1 and 2 of Cam/Clutch Service.

When replacing the camgear, it will be necessary to adjust (by selecting the correct shim) the camgear to pinion gear backlash using the following procedure:

1. Reassemble camgear/disc pack sub-assembly, per reassembly procedure.
  2. Install the new camgear and disc pack sub-assembly, using the original shim, into the flange end of the case. Place pinion gears and pinion thrust washers into their respective locations in the case, manually depress the camgear into its bore and slide the pinion shaft through the case and both pinion gears.
- If installation of the pinion shaft is prevented by the pinion gears, it will be necessary to replace the original shim with one of less thickness.) Once the pinion shaft is installed, with lockscrew in place, index one tooth of the pinion gear nearest the pinion shaft lockscrew so that it points downward perpendicular to the case flange.
3. Use a large tapered screwdriver or similar shaped tool and firmly wedge it between the camgear and pinion shaft. Using a dial indicator mounted to the case flange (Fig. 6), check pinion to camgear backlash by pulling the pinion gear firmly into its seat and rotate back and forth while reading the gage, note reading. Repeat the above procedure of indexing and checking backlash of the pinion gear opposite the pinion shaft lockscrew, and note reading.

If backlash is not between .010 and .018, change shim size and repeat backlash procedure until the correct backlash is obtained. The thinner the shim used the greater the backlash reading will be.

**NOTICE:** When camgear and/or side gear is replaced, thrust block replacement and clearance procedure must be followed during reassembly of the unit. Failure to do so may disturb critical clearances and could result in differential complaints.

### Side Gear (R.H.)

#### Replacement

If it is necessary to replace the side gear due to pitting of the teeth scoring of the hub, or breakage it will be necessary to disassemble the unit as described in Steps 1 through 6 case disassembly. When replacing the side gear it will be necessary to adjust (by selecting the correct shim) the side gear to pinion gear backlash using a similar procedure as described in the camgear replacement. However, backlash for the side gear should be adjusted to within .002-.010, with R.H. side gear wedged against case.

### Thrust Block Replacement and Clearance

If it is necessary to replace the thrust block only, replace it with a new one of identical thickness. If the thrust block is broken, check for other damage and replace parts as necessary. If case is damaged, replace the entire unit.

If camgear and/or side gear is replaced, it will be necessary to check the side gear spread dimension and adjust block clearance as follows:

1. Install camgear and disc pack with camgear shim into the flange end of the case. Install side gear and disc pack with shim into the bell end of the case.
2. Install pinion shaft and lockscrew into case. Firmly wedge a large tapered screwdriver or similar shaped tool between the pinion shaft and camgear. Wedge another tapered tool between the pinion shaft and side gear.
3. Using a 1" to 2" telescoping gage, measure the distance between the camgear face and side gear face (side gear spread).

**NOTICE:** Make sure telescoping gage ends rest on the gear face, not on the gear teeth (Fig. 7). Measure the

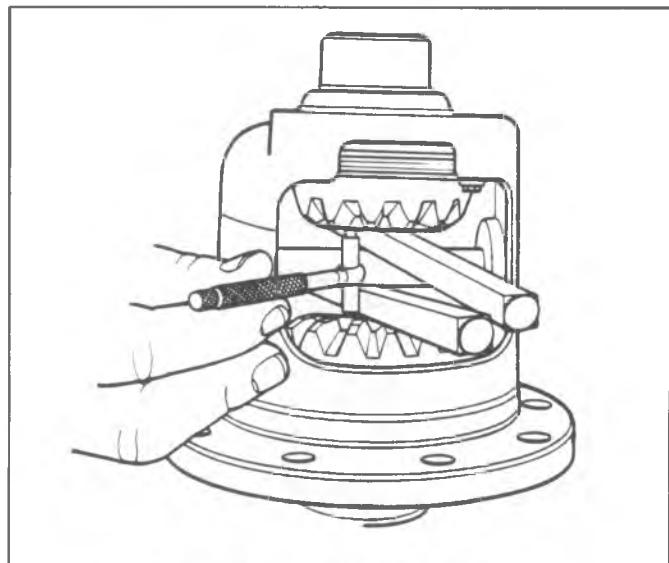

Fig. 7--Measuring Side Gear Spread

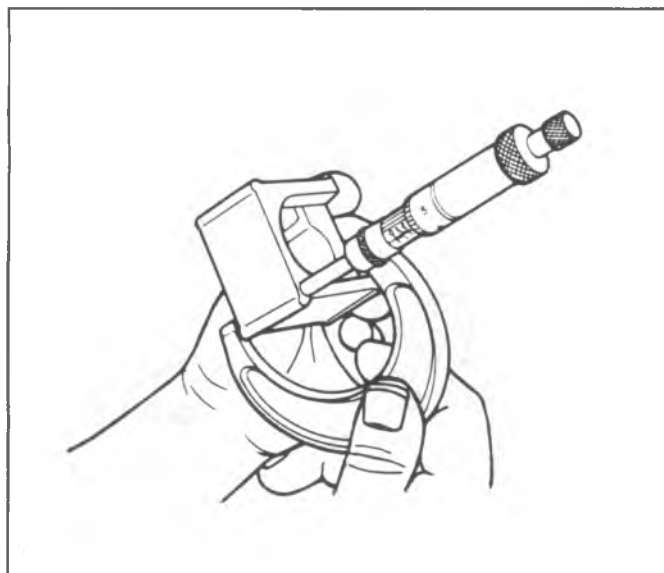

Fig. 8--Measuring Thrust Block

telescoping gage with a 1" to 2" micrometer and not reading. Next, measure the thickness of the original thrust block at outer corner (Fig. 8) and note reading.

If the thrust block thickness is not within a range of .000 to .006 less than the side gear spread, adjust clearance with one of the following procedures:

- a. Reshim R.H. Clutch Disc Pack. Note: Backlash of .002 - .010 must still be maintained.
- b. Select a new thrust block of the correct size to obtain .000 to .006 clearance.

Once the proper thrust block clearance has been obtained, continue reassembly of case.

## CASE

### Reassembly (Fig. 2)

1. Install (4) clutch pack guide clips on the ears of the cam gear clutch pack using grease for retention.
2. Install cam gear assembly and original shim in flange end of case. If new cam gear is installed, see differential gear replacement.

3. Lock an axle shaft in vise, in a vertical position. Mount the differential case over the end of the axle shaft engaging the spline of the side gear with the shaft. Assemble on to bell end gear hub(3) splined discs and (4) eared discs alternately as shown. Begin and end with an eared disc. Install (4) small clutch pack guide clips on the ears of the bell end clutch pack using grease for retention. Install in case with shim. If new R.H. side gear is installed, refer to differential gear replacement.
4. Install thrust washers onto back surfaces of pinion gears. Use small amount of grease to adhere washers to gears. Insert one pinion gear through the small window opening in the case while at the same time inserting the reaction block and other pinion gear through the large window opening. Rotate the two pinion gears and thrust block 90° so as to position the reaction block with the open side towards the small window opening in the case. Be sure the two pinion gears and thrust washers are in their proper location.

**NOTICE:** Thrust block thickness is critical to proper differential function. If new side gears or thrust blocks are installed, refer to instructions in differential gear thrust block replacement.

5. Install pinion shaft and lock screw. A new lock screw must used on assembly.
6. Insert governor assembly and latching bracket into case, Figure 3. Place straight end of latching bracket spring over and to the outside of the engagement shaft to preload the latching bracket against the governor assembly. Press bushing for governor assembly into case to give .004 to .020 shaft end play. A 3/8" diameter plug or socket will aid in pressing the bushing into the housing. Press latching bracket assembly bushing into case to provide .000-.003 shaft end play.
7. Install ring gear and side bearings using the procedure outlined for standards differentials.
8. Place differential unit in carrier and adjust ring gear and pinion backlash and gear tooth pattern as outlined in the standard differential section.
9. Check operation as outlined in Service Test Procedure.

**NOTICE:** Use only the rear axle lubricant recommended in Maintenance and Lubrication Section. The usage of any other lubricant or any additive may result in damage to the differential.

## UNIT REPAIR

### 8-7/8" RING GEAR

Due to critical internal clearance dimensions, the differential side gears and case cannot be serviced separately. If any side gear or case damage is found the entire differential must be replaced.

Internal clearances are such that shims, thrust block and thrust ring should not be replaced unnecessarily even if slight wear indications are present. If shims, thrust block, or thrust ring must be replaced due to damage, correct measurement and replacement procedures must be followed. Failure to do so may disturb critical clearances and could result in differential complaints.

Internal components can be inspected through the windows of the differential housing.

If the governor assembly and latching bracket are the only items to be replaced, proceed only through Step No. 2 of the disassembly procedure. To install new governor and latching bracket, begin at Step No. 6 of the 39 reassembly procedure.

## CASE

### Disassembly

1. Note position of governor and latching bracket assembly, Fig. 10. Remove ring gear and side bearings following procedures established for the standard

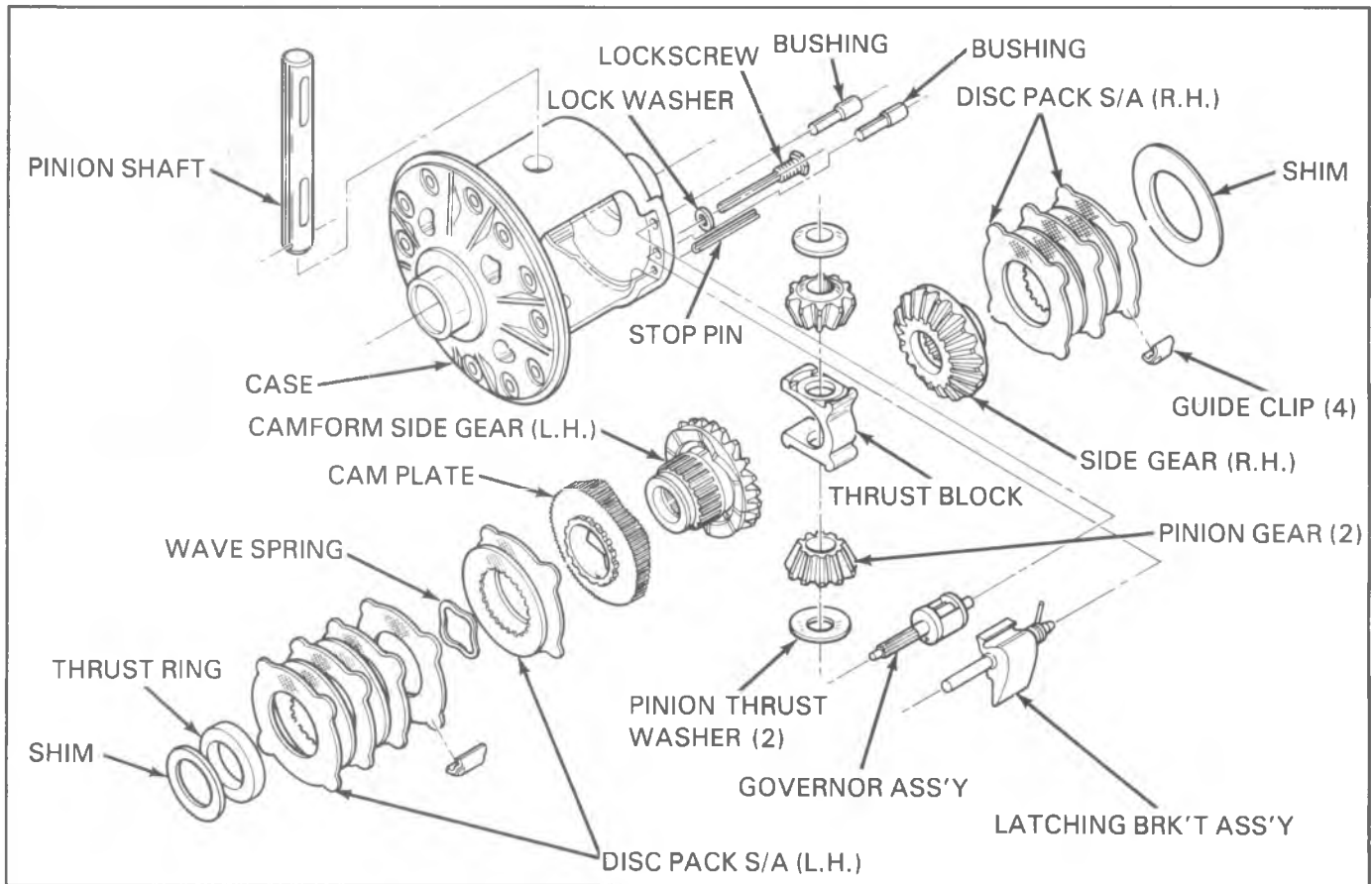

Fig. 9--8-7/8" Ring Gear

- differential.
- Using bushing puller tool J-26252, remove governor assembly and latching bracket by pulling the retaining bushings as shown in Figure 11. Pull the latching bracket spring out of the way while pulling the governor assembly bushing to prevent damage. Remove the stop pin by driving through the case with a drive pin punch.
  - Remove lock screw and pinion shaft, and roll out differential pinion gears.

- Remove thrust block and pinion thrust washers.
- Remove R.H. side gear, disc pack and shims.
- Remove L.H. cam gear, disc pack assembly and disc pack guide clips.

#### Inspection

- Clean all parts with solvent. Inspect all bearings for chipping or evidence of excessive wear. Replace parts as needed.
- Inspect all differential components for excessive wear and breakage. Replace parts as needed. The following are serviceable components for this differential:
  - Governor assembly and latching bracket with spring and stop pin.
  - Cam plate.
  - Clutch disc pack with guid clips (R.H. and L.H.)
  - Pinion cross shaft.
  - Pinion gears.
  - Pinion thrust washers.
  - Thrust block (4 sizes).
  - Thrust ring.
  - Flange end shim (4 sizes).

**NOTICE:** Attempts to service other components may disturb critical clearances and could result in differential complaints.

**NOTICE:** If thrust block or flange end shim must be replaced, the original pieces must be carefully measured for thickness and replaced with a piece of the same size.

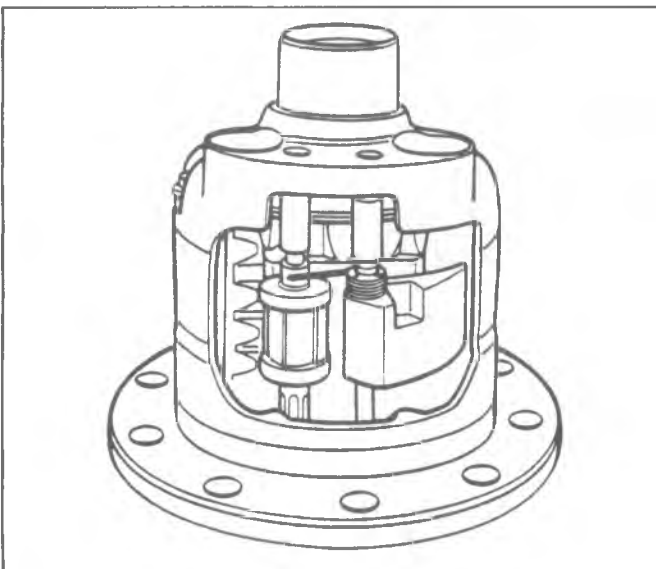

Fig. 10--Governor and Latching Bracket

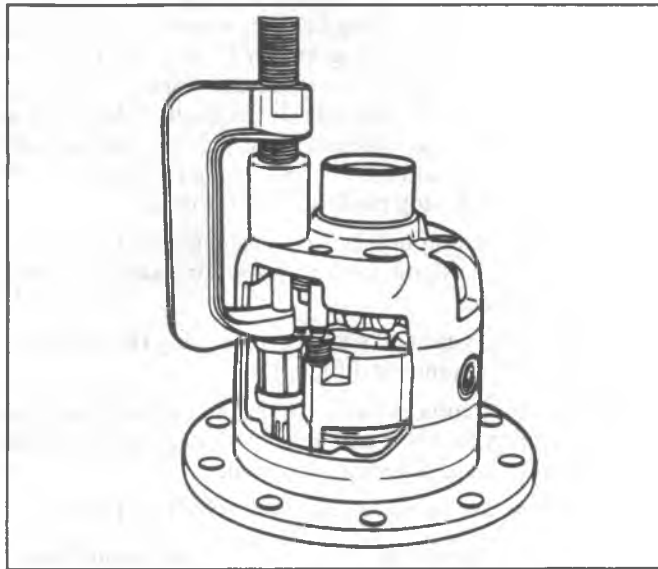

Fig. 11--Bearing Puller J-26252

## CAM/CLUTCH SERVICE (L.H.)

### Disassembly

If cam plate or clutch discs must be replaced, the cam gear sub-assembly must be serviced as follows:

1. Measure and record overall length of gear assembly (from face of gear to back side of thrust ring, include shim). This dimension will be needed to reassembly unit if thrust ring is replaced. **DO NOT REPLACE THRUST RING UNLESS NECESSARY.** If ring is excessively worn or scored, check bore in case for scoring. If bore is scored, replace entire differential.
2. With gear hub end up, compress disc pack and install jaws of split ring bearing remover (J-22912) between the thrust ring and the top disc. Bevel side of bearing remover should face up toward thrust ring.
3. Place cam gear assembly with bearing remover attached in an arbor press supporting the bearing remover on both sides.
4. Install a 1-1/2" diameter plug similar to (J-8107-4) on gear hub. Press against plug with ram of press to remove thrust ring. Keep all components in the proper order, Figure 12.

### Reassembly

Replace cam plate and wave spring or clutch discs as necessary and reassemble as follows: See Fig. 9.

1. Place gear on bench with hub end up.
2. Assemble cam plate with cam form down to mate with cam form on gear.
3. Assemble onto cam plate: (2) eared discs, (1) splined disc, and (1) wave spring alternately as shown.
4. Assembly on to gear hub (2) splined discs and (3) eared discs alternately as shown. Begin with a splined disc and end with an eared disc.
5. Locate cam gear assembly in arbor press with hub end up.. Place thrust ring on gear hub and press to shoulder making sure that ring is square with hub.

- a. Compress disc pack by pushing down on the discs to keep the splined discs from becoming wedged between the thrust ring and gear shoulder while pressing the sub-assembly together. Completed sub-assembly should be checked for proper disc sequence. Also, make sure the first splined disc (large spline) is properly located on the cam plate.

## Clutch Pack (R.H.)

### Disassembly

1. Remove disc pack and shim from side gear. Keep discs in order.

### Reassembly

1. Replace discs and/or clips, as required.
2. Reassembly material on gear hub (two splined discs and three eared discs) alternately as shown in Fig. 9. Maintain original sequence, if new discs are not used. Reinstall original shim, or a new shim with original thickness.

**NOTICE:** If gear hubs are scored, rough or show abnormal wear, check condition of bores in case. If they are damaged or oversize, the entire unit must be replaced.

### Reassembly

1. Install (4) clutch pack guide clips on the ears of the cam gear clutch pack using grease for retention.
2. Install cam gear assembly and original shim in flange end of case. If a new thrust ring has been pressed on the cam gear, reshimming may be necessary. Measure the overall length of the new cam gear assembly, including the shim and compare to the dimension obtained in Step 1 of cam gear service section. If the length of the new assembly varies by more than .003" larger or smaller than the original dimension, reshimming will be necessary. Select a shim which will result in a reading closest to the original.

**NOTICE:** Incorrect shimming will disturb critical clearance dimensions and may result in differential failure.

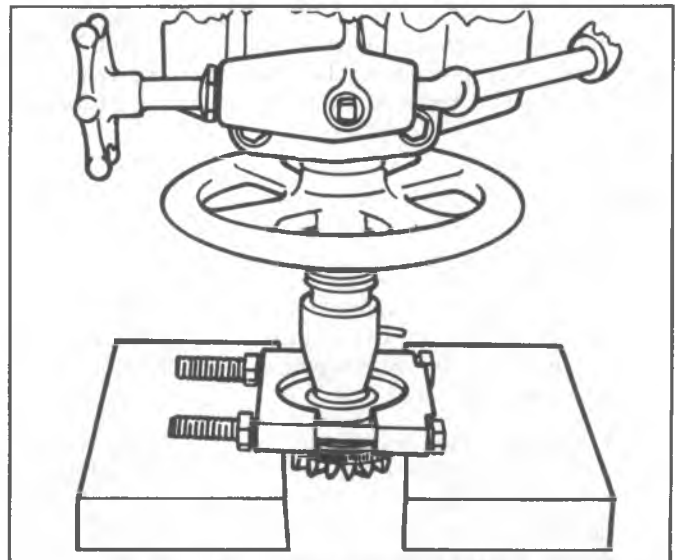

Fig. 12--Bearing Remover J-22912

3. Lock an axle shaft in vise, in a vertical position. Mount the differential case over the end of the axle shaft engaging the spline of the side gear with the shaft. Grease the two pinion gear thrust washers and locate them in their proper position. Install bell end (R.H.) side gear, disc pack, and original shim. Original shim must be used to maintain proper clearance dimensions.
  4. Insert one pinion gear through the small window opening in the case while at the same time inserting the thrust block and other pinion gear through the large window opening. Rotate the two pinion gears and thrust block 90° so as to position the reaction block with the open side towards the small window opening in the case. Be sure the two pinion gears and thrust washers are in their proper location.
- NOTICE:** Thrust block must be replaced with a block of the identical thickness. Incorrect block thickness will disturb critical clearance dimensions and may result in differential failure.
5. Install shaft and lock screw.
  6. Insert governor assembly and latching bracket into case, Figure 10. Place straight end of latching bracket

spring over and to the outside of the engagement shaft to preload the latching bracket against the governor assembly. Press bushing and 1/4" stop pin into case. Press bushing for governor assembly into case to give .004 to .020 shaft end play. Press bushing for latching bracket into case to remove end play. A 3/8 diameter plug or socket will aid in pressing the bushings into the housing. Press stop pin flush with top of case.

For the latching bracket use bushing with the tapered hole. The bushing for the governor assembly has a straight hole.

7. Install ring gear and side bearings using the procedure outlined for standard differentials.
8. Place differential unit in carrier and adjust ring gear and pinion backlash and gear tooth pattern as outlined in the standard differential section.
9. Check operation as outlined in Service Test Procedure.

**NOTICE:** Use only the rear axle lubricant recommended in the Maintenance and Lubrication Section. The usage of any other lubricant or any additive may result in damage to the differential.

## UNIT REPAIR

### 9-1/2" RING GEAR

Due to critical internal clearance dimensions, the differential case cannot be serviced separately. If any case damage is found, the entire differential must be replaced.

Internal clearances are such that shims, thrust block, thrust or gears should not be replaced unnecessarily even if ring, slight wear indications are present. If shims, thrust block, thrust ring, or gears must be replaced due to damage, correct measurement and replacement procedures must be followed. Failure to do so may disturb critical clearances and could result in differential complaints.

Internal components can be inspected through the windows of the differential housing.

If the governor assembly and latching bracket are the only items to be replaced, proceed only through Step No. 2 of the disassembly procedure. To install new governor and latching bracket, begin at Step No. 6 of the reassembly procedure.

## CASE

### Disassembly

1. Note position of governor and latching bracket assembly, Figure 14. Remove ring gear and side bearings following procedures established for the standard differential.
2. Using bushing puller tool No. J-26252, remove governor assembly and latching bracket by pulling the retaining bushings as shown in Figure 15. Pull the latching bracket spring out of the way while pulling the governor assembly bushing to prevent damage. Remove the stop pin by driving through the case with a 1/4" drive pin punch.

3. Remove lock screw and pinion shaft and roll out differential pinion gears and pinion thrust washers.
5. Remove R.H. side gear, disc pack and shims.
6. Remove cam gear, disc pack assembly and disc pack guide clips.

### Inspection

1. Clean all parts with solvent. Inspect all bearing for chipping or evidence of excessive wear. Replace parts as needed.
2. Inspect all differential components for excessive wear and breakage. Replace parts as needed. The following are serviceable components for this differential:
  - Governor assembly and latching bracket with spring and stop pin.
  - Cam plate.
  - Clutch disc pack with guide clips, R.H. and L.H.
  - Pinion cross-shaft.
  - Lockscrew.
  - Pinion gears.
  - L. H. Side gear.
  - R. H. Side Gear
  - Pinion thrust washers.
  - Thrust block (9 sizes).
  - Thrust ring.
  - L.H. side gear.
  - L.H. side gear shim (9 sizes)
  - R.H. side gear shim (8 sizes)
  - Disc guide clips (Both L.H. and R.H.)

**NOTICE:** If thrust block or flange end shim must be replaced, the original pieces must be carefully measured for thickness and replaced with a piece of the



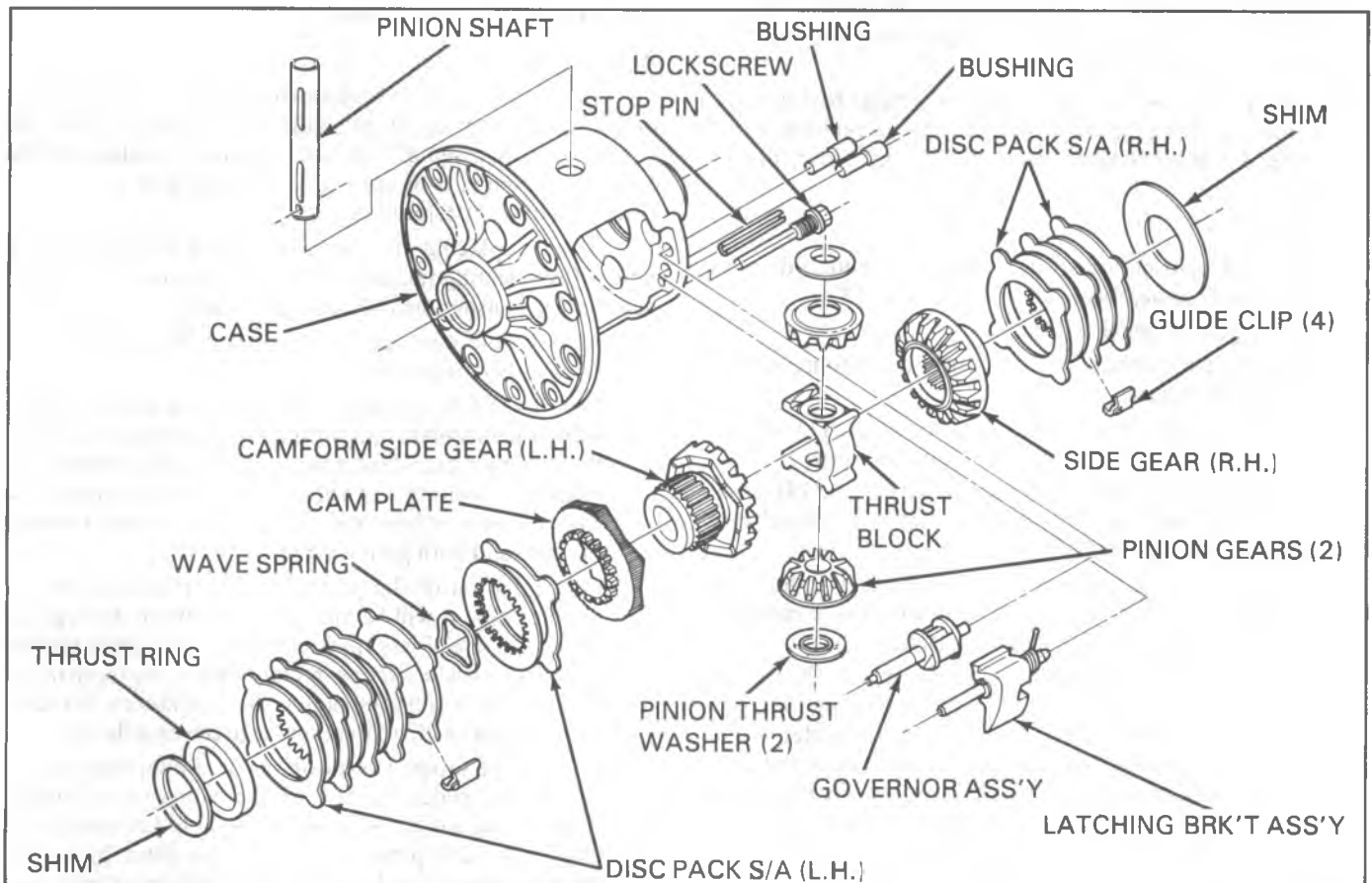

Fig. 13-9-1/2" Ring Gear

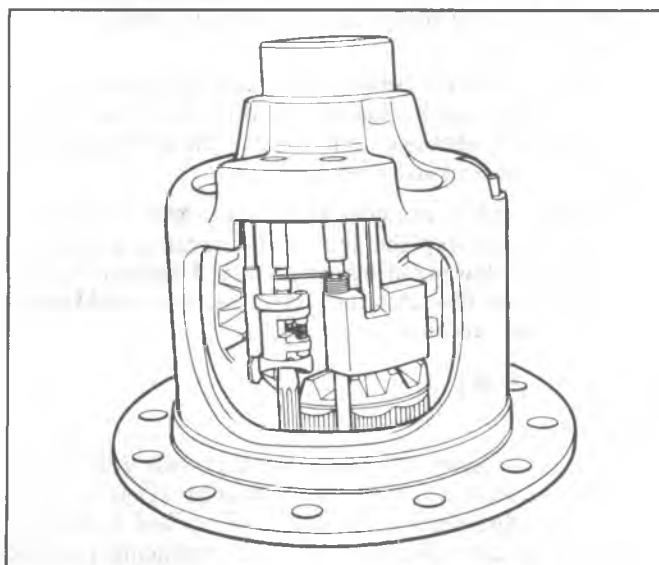

Fig. 14-Governor and Latching Bracket

same size.

### CAM/CLUTCH SERVICE

#### Disassembly

If cam gear (L.H. side gear) and cam plate or clutch discs must be replaced, the cam gear sub-assembly must be serviced as follows:

1. Measure and record overall length of gear assembly (front face of gear to back side of thrust ring, include

shim). This dimension will be needed to reassemble unit if cam gear or thrust ring is replaced. **DO NOT REPLACE THRUST RING UNLESS NECESSARY.** If ring is excessively worn or scored, check bore in case for scoring. If bore is scored, replace entire differential.

2. With gear hub end up, compress disc pack and install jaws of split ring bearing remover (J-22912) between the thrust ring and the top eared disc. Bevel side of bearing remover should face up toward thrust ring.

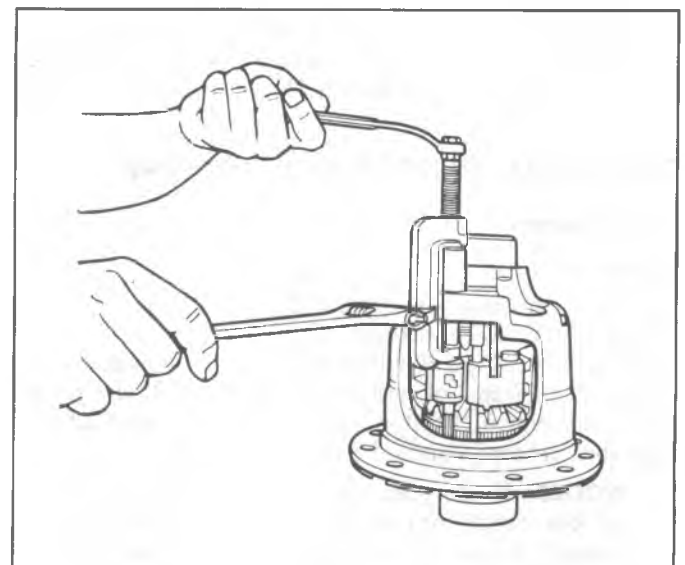

Fig. 15-Bearing Puller J-26252

- Place cam gear assembly with bearing remover attached in an arbor press supporting the bearing remover on both sides.
- Install a 1-3/4" diameter plug or similar tool on hub. Press against plug with ram of press to remove thrust ring. Keep all components in the proper order, Figure 16.

#### Reassembly

Replace cam plate and wave spring or clutch discs as necessary and reassembly as follows: See Fig. 13.

- Place gear on bench with hub end up.
- Assembly cam plate with cam form down to mate with cam form on gear.
- Assemble onto cam plate: (2) eared discs, (1) splined disc, and (1) wave spring alternately as shown.
- Assemble on to gear hub (3) splined discs and (4) eared discs alternately as shown. Begin with a splined disc and end with an eared disc.
- Locate cam gear assembly in arbor press with hub end up. Place thrust ring on gear hub and press to shoulder making sure that ring is square with hub.
  - Compress disc pack by pushing down on the discs to keep the splined discs from becoming wedged between the thrust ring and gear shoulder while pressing the sub-assembly together. Completed sub-assembly should be checked for proper disc sequence. Also, make sure the first splined disc (large spline) is properly located on the cam plate.

#### Clutch Pack (R.H.)

##### Disassembly

- Remove disc pack and shim from side gear. Keep discs in order.

##### Reassembly

- Replace disc and/or clips, as required.
- Reassemble material on gear hub (two splined discs and three eared discs) alternately as shown in Fig. 13. Maintain original sequence, if new discs are not used. Reinstall original shim, or a new shim with original thickness.

**NOTICE:** If gear hubs are scored, rough or show abnormal wear, check condition of bores in case. If they are damaged or oversize, the entire unit must be replaced.

### DIFFERENTIAL THRUST BLOCK AND GEAR

#### Pinion Gears

##### Replacement

If it is necessary to replace the pinion gears due to pitting of the teeth, scoring of the pinion shaft bearing surface, or breakage, it will be necessary to disassemble the unit through Step 3 of case disassembly. Install new pinion gears and pinion thrust washers, and reassemble unit as described in Steps 4 through 9 of case reassembly.

**NOTICE:** If camgear, side gear, or pinion gears are broken, check for other damage and replace parts as needed. If case is damaged the entire unit must be replaced.

#### Camgear (L.H. Side Gear)

##### Replacement

If it is necessary to replace the camgear due to pitting of the teeth, scoring of the hub, or breakage, it will be necessary to disassemble the unit completely as described in Steps 1 through 6 of case disassembly and in Steps 1 through 4 of Cam/Clutch Service.

When replacing the camgear, it will be necessary to adjust (by selecting the correct shim) the camgear to pinion gear backlash using the following procedure:

- Reassemble cam gear/disc pack sub assembly, per reassembly procedure.
- Install the new camgear and disc pack sub assembly, using the original shim, into the flange end of the case. Place pinion gears and pinion thrust washers into their respective locations in the case, manually depress the camgear into its bore and slide the pinion shaft through the case and both pinion gears.

If installation of the pinion shaft is prevented by the pinion gears, it will be necessary to replace the original shim with one of less thickness. Once the pinion shaft is installed, with lock screw in place, index one tooth of the pinion gear nearest the pinion shaft lock screw so that it points downward, perpendicular to the case flange.

- Use a large tapered screwdriver or similar shaped tool and firmly wedge it between the camgear and pinion shaft. Using a dial indicator mounted to the case flange (Fig. 17) check pinion to camgear backlash by pulling the pinion gear firmly into its seat and rotate back and forth while reading the gage, note reading. Repeat the above procedure of indexing and checking backlash of the pinion gear opposite the pinion shaft lock screw, and note reading.

If backlash is not between .010 and .018, change shim size and repeat backlash procedure until the correct backlash is obtained. The thinner the shim used, the greater the backlash reading will be.

**NOTICE:** When camgear and/or side gear is replaced, thrust block replacement and clearance procedure must be followed during reassembly of the unit. Failure to do so may disturb critical clearances and could result in differential complaints.

#### Side Gear (R.H.)

##### Replacement

If it is necessary to replace the R.H. side gear due to pitting of the teeth, scoring of the hub, or breakage it will be necessary to disassemble the unit as described in Steps 1 through 6 of case disassembly. When replacing the side gear, it will be necessary to adjust (by selecting the correct shim) the side gear to pinion gear backlash using a similar procedure as described in the camgear replacement. However, backlash for the side gear should be adjusted to within .002-.010, with R.H. side gear wedged against case.

#### Thrust Block Replacement and Clearance

If it is necessary to replace the thrust block only, replace it with a new one of identical thickness. If the thrust block is broken, check for other damage and replace parts as necessary. If case is damaged, replace the entire

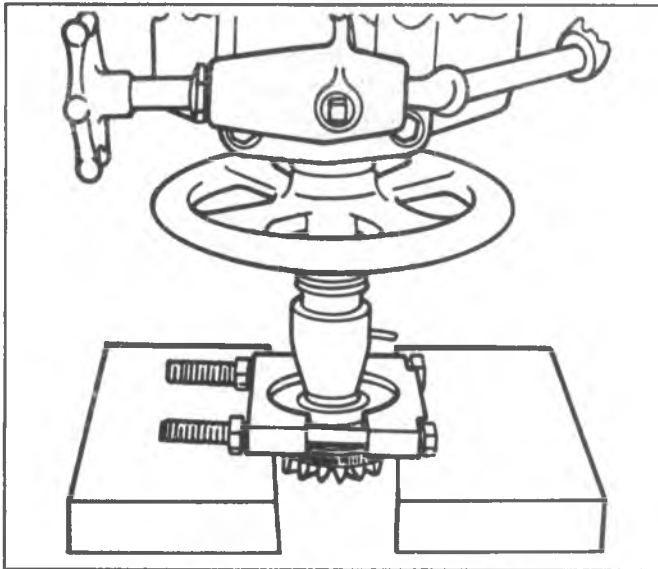

Fig. 16--Bearing Remover J-22912-01

unit.

If camgear and/or side gear is replaced, it will be necessary to check the side gear spread dimension and adjust block clearance as follows:

1. Install camgear and disc pack with camgear shim into the flange end of the case. Install side gear and disc pack with shim into the bell end of the case.
2. Install pinion shaft and lock screw into case. Firmly wedge a large tapered screwdriver or similar shaped tool between the pinion shaft and camgear. Wedge another tapered tool between the pinion shaft and side gear.
3. Using a 1" to 2" telescoping gage measure the distance between the camgear face and side gear face (side gear spread).

**NOTICE:** Make sure telescoping gage ends rest on the gear face, not on the gear teeth (Fig. 18).

4. Measure the telescoping gage with a 1" to 2" micrometer and note reading. Next, measure the

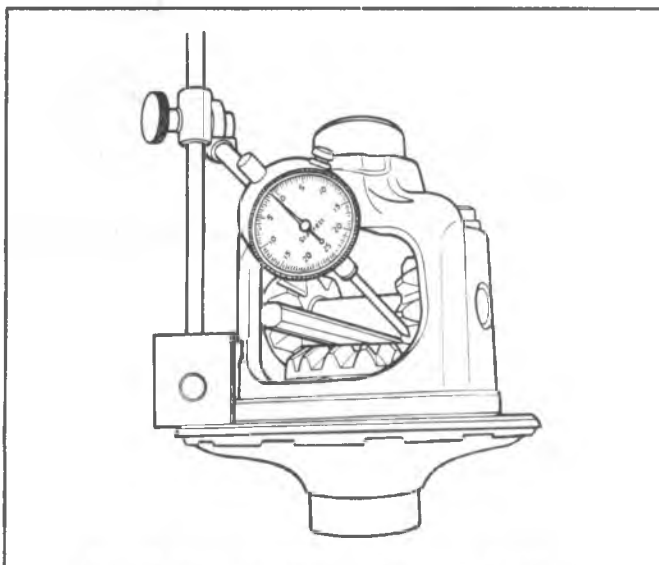

Fig. 17--Measuring Pinion to Camgear Backlash

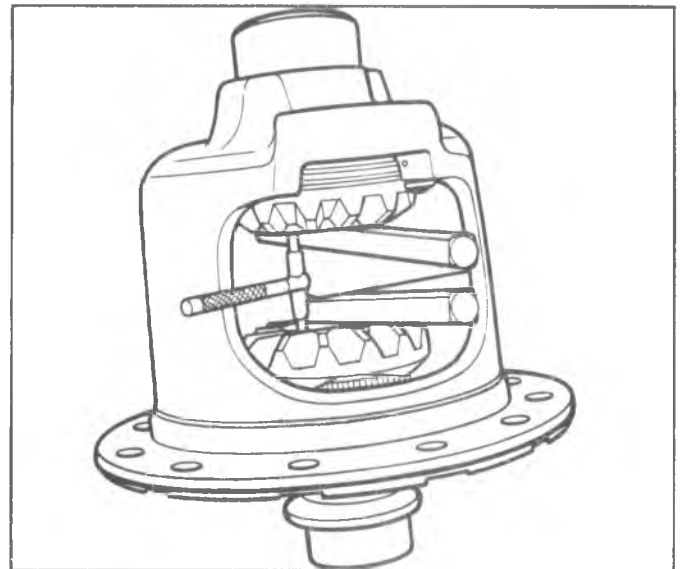

Fig. 18--Measuring Side Gear Spread

thickness of the original thrust block at outer corner (Fig. 19) and note reading..

If the thrust block thickness is not within a range of .000 to .006 less than the side gear spread, adjust clearance with one of the following procedures:

- a. Reshim R.H. clutch disc pack. Note: Backlash of .002-.010 must still be maintained.
- b. Select a new thrust block of the correct size to obtain .000 to .006 clearance.

Once the proper thrust block clearance has been obtained, continue reassembly of case.

### CASE REASSEMBLY

#### Reassembly

1. Install (4) clutch pack guide clips on the ears of the camgear clutch pack using grease for retention.
2. Install cam gear assembly and original shim in flange end of case. If new cam gear is installed, refer to differential gear replacement procedure. If a new thrust ring has been pressed on the cam gear,

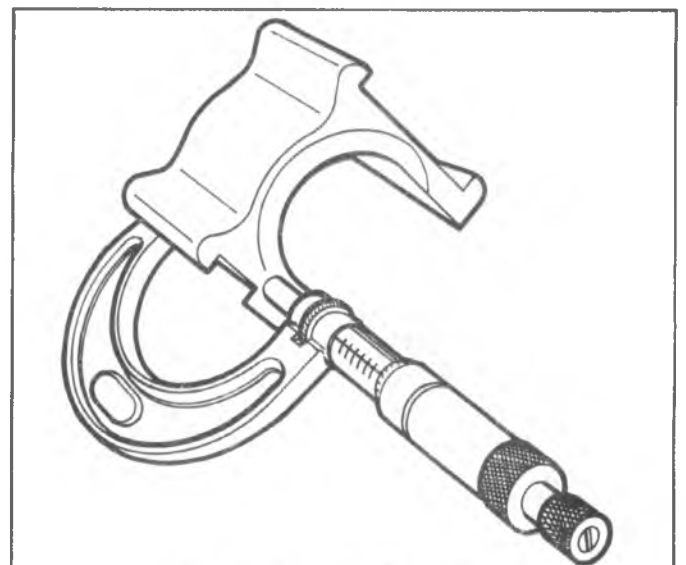

Fig. 19--Measuring Thrust Block

reshimming may be necessary. Measure the overall length of the new cam gear assembly, including the shim and compare to the dimension obtained in Step 1 of cam gear service procedure. If the length of the new assembly varies by more than .003" larger or smaller than the original dimension, reshimming will be necessary. Select a shim which will result in a reading closest to the original.

**NOTICE:** Incorrect shimming will disturb critical clearance dimensions and may result in differential complaints.

3. Lock an axle shaft in vise, in a vertical position. Mount the differential case over the end of the axle shaft engaging the spline of the side gear with the shaft. Assemble on to bell end (R.H.) gear hub (2) splined discs and (3) eared discs alternately as shown. Begin and end with an eared disc. Install (4) small clutch pack guide clips on the ears of the bell end clutch pack using grease for retention. Install in case with shim if new R.H. side gear is installed, refer to differential gear replacement procedure.
4. Install thrust washers onto back surfaces of pinion gears. Use small amount of grease to adhere washers to gears. Insert one pinion gear through the small window opening in the case while at the same time inserting the reaction block and other pinion gear through the large window opening. Rotate the two pinion gears and thrust block 90° so as to position the reaction block with the open side towards the small window opening in the

case. Be sure the two pinion gears and thrust washers are in their proper location.

**NOTICE:** Thrust block thickness is critical to proper differential function. If new side gears or thrust block is installed, see instructions in differential gear/thrust block section.

5. Install pinion shaft and lockscrew.
6. Insert governor assembly and latching bracket into case, Figure 14. Place straight end of latching bracket spring over and to the outside of the engagement shaft to preload the latching bracket against the governor assembly. Press bushing and 1/4" stop pin into case. Press bushing for governor assembly into case to give .004 to .020 shaft end play. Press bushing for latching bracket into case to remove end play. A 3/8 diameter plug or socket will aid in pressing the bushings into the housing. Press stop pin flush with top of case. For the latching bracket, use bushing with the tapered hole. The bushing for the governor assembly has a straight hole.
7. Install ring gear and side bearings using the procedure outlined for standard differentials.
8. Place differential unit in carrier and adjust ring gear and pinion backlash and gear tooth pattern as outlined in the standard differential section.
9. Check operation as outlined in Service Test Procedure.

**NOTICE:** Use only the rear axle lubricant recommended in Maintenance and Lubrication Section. The usage of any other lubricant or any additive may result in damage to the differential.

## UNIT REPAIR

### 10-1/2" RING GEAR

Due to critical internal clearance dimensions, the differential case cannot be serviced separately. If any case damage is found, the entire differential must be replaced.

Internal clearances are such that shims, thrust blocks, thrust ring or gears should not be replaced unnecessarily even if slight wear indications are present. If shims, thrust blocks, thrust ring or gears must be replaced due to damage, correct measurement and replacement procedures must be followed. Failure to do so may disturb critical clearances and could result in differential complaints.

#### CASE

##### Disassembly

1. Remove ring gear and side bearings following procedures established for the standard differential.
2. Remove (3) screws on front face of ring gear flange.
3. Set unit on right side case half and gently pry apart at yoke hole location (Fig. 21.).
4. Remove left side case half. To prevent side gear from falling out, hold thumb against inside of gear hub while separating case halves.
5. Inspect components for damage. If the governor assembly and latching bracket are the only items to be

replaced, remove and proceed to Step 7 of reassembly procedure. Pry under pinion yoke and remove and proceed with detailed inspection if further damage is observed.

##### Inspection

1. Clean all parts with solvent. Inspect all bearings for chipping or evidence of excessive wear. Replace parts as needed.
2. Inspect all differential components for excessive wear and breakage. Replace parts as needed. **The following are serviceable components for this differential.**
  - Governor assembly and latching bracket with spring.
  - Cam Plate.
  - Clutch disc pack with wave spring and guide clips (R.H.)
  - Pinion yoke.
  - Pinion gears.
  - Pinion thrust washers.
  - Clutch disc pack with guide clips (L.H.).
  - L.H. side gear.
  - R.H. side gear (camgear).
  - Thrust blocks (4 sizes).

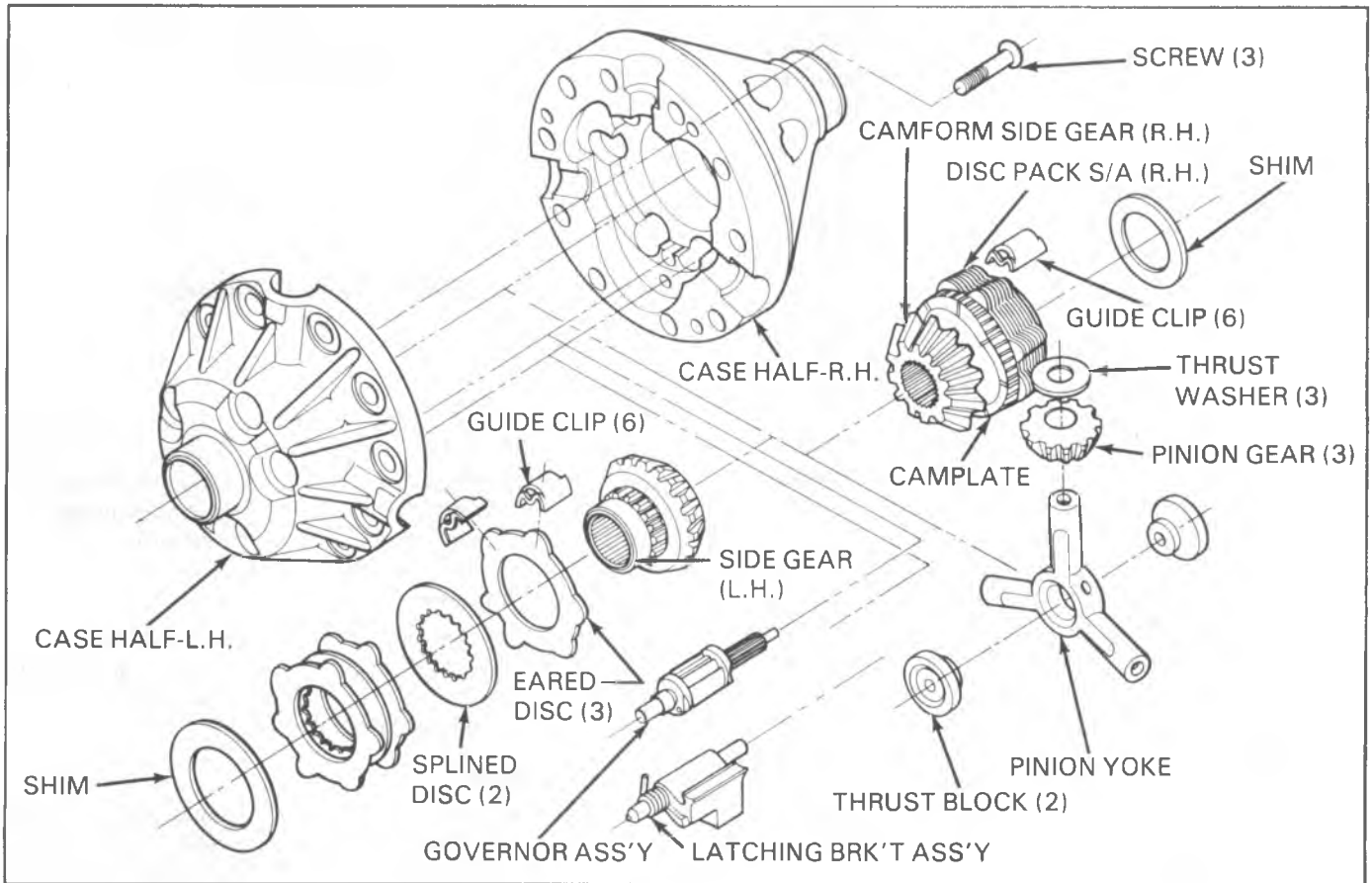

Fig. 20--10-1/2" Ring Gear

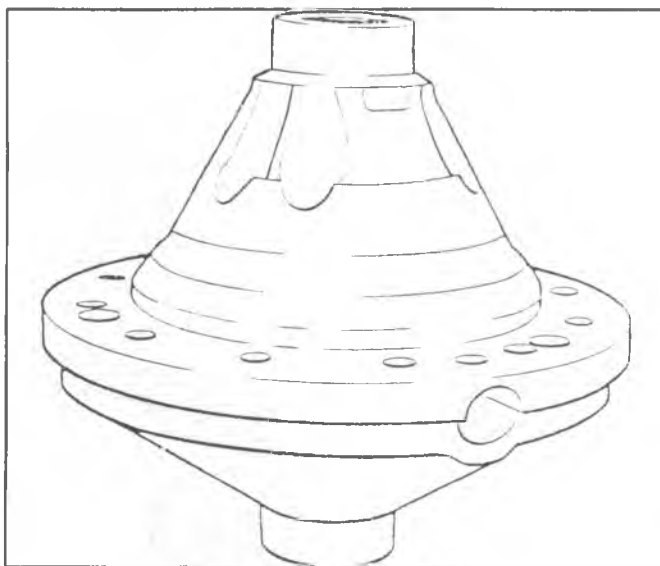

Fig. 21--Differential Case

- Thrust ring.
- Right side shim (4 sizes).
- Guide clips, LH and RH.

**CAM/CLUTCH SERVICE**

**Disassembly**

If camgear or cam plate or clutch discs must be replaced, the cam gear sub-assembly must be serviced as follows: Refer to Figure 23.

1. Measure and record overall length of gear assembly (front face of gear to back side of thrust ring, include shim). This dimension will be needed to reassemble unit if thrust ring is replaced. **Do not replace thrust ring unless necessary.** If ring is excessively worn or scored, check bore in case for scoring. If bore is scored, replace entire differential.
2. With gear hub end up, compress disc pack and install jaws of split ring bearing removed (J-22912)

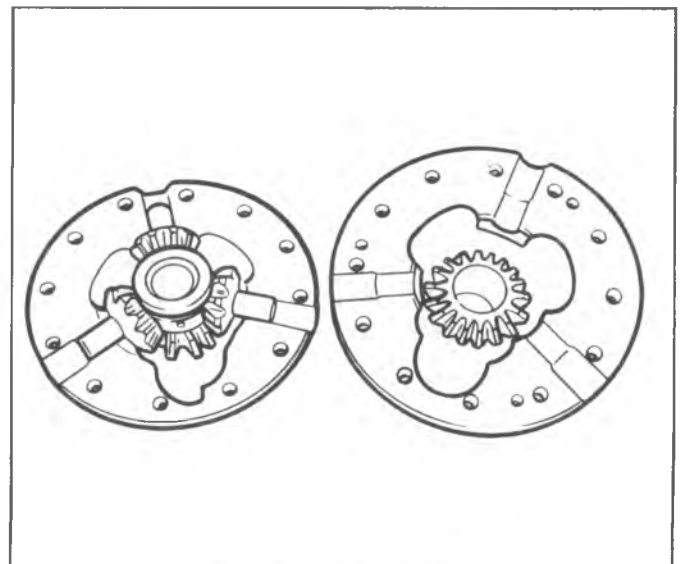

Fig. 22--Differential Halves

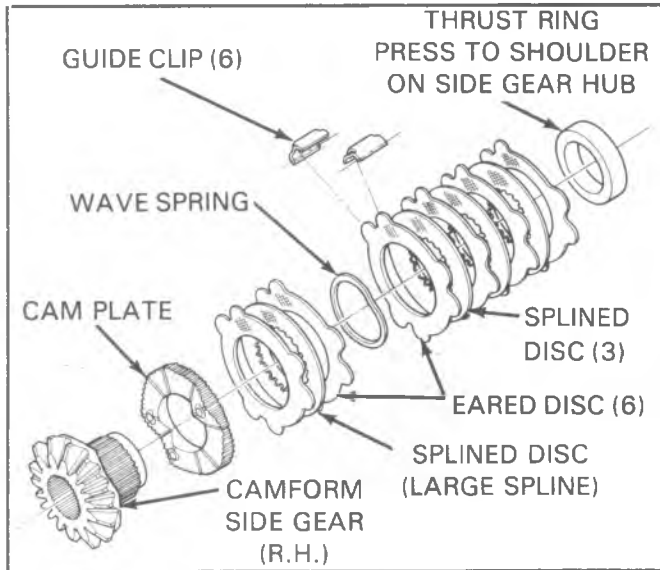

Fig. 23--Cam Plate and Clutch Discs

between the thrust ring and the top eared disc. Bevel side of bearing remover should face up toward thrust ring.

3. Place cam gear assembly with bearing remover attached in an arbor press supporting the bearing remover on both sides (Fig. 24).
4. Install a 1-3/4" diameter plug on gear hub. Press against plug with ram of press to remove thrust ring. Keep all components in the proper order.

**Reassembly**

Replace cam plate and/or clutch disc as necessary and reassembly as follows:

1. Place gear on bench with hub end up.
2. Assemble cam plate with cam form down to mate with cam form on gear.
3. Assemble onto cam plate (2) eared discs, (1) splined disc, and (1) wave spring alternately as shown (Fig. 23).
4. Assemble onto gear hub: (4) eared discs and (3) splined discs alternately as shown. Begin and end with an eared disc.
5. Locate cam gear assembly in arbor press with hub end up. Place thrust ring on gear hub and press to shoulder making sure that ring is square with hub.
  - a. Compress disc pack by pushing down on the discs to keep the splined discs from becoming wedged between the thrust ring and gear shoulder while pressing the sub-assembly together. Completed sub-assembly should be checked for proper disc sequence. Also, make sure the first splined disc (large spline) is properly located on the cam plate.

**Clutch Pack (L.H.)**

**Disassembly**

1. Remove disc pack and shim from side gear. Keep discs in order.

**Reassembly**

1. Replace discs and /or clips, as required.

2. Reassemble material on gear hub (two splined discs and three eared discs) alternately as shown in Fig. 23. Maintain original sequence, if new discs are not used. Reinstall original shim, or a new shim with original thickness.

**NOTICE:** If gear hubs are scored, rough or show abnormal wear, check condition of bores in case. If they are damaged or oversize, the entire unit must be replaced.

**GEAR REPLACEMENT AND BACKLASH**

**Pinion Gears**

**Replacement**

If it is necessary to replace the pinion gears due to pitting of the teeth, scoring of the pinion yoke bearing surface, or breakage, it will be necessary to disassemble the unit through Step 5 of the case disassembly procedure. Install new pinion gears and pinion thrust washers and reassemble unit as described in Steps 4 through 13 of the case reassembly procedure.

**NOTICE:** If camgear (R.H.), side gear (L.H.), or pinion gears are broken, check for other damage and replace parts as needed. If either R.H. or L.H. case is damaged the entire unit must be replaced.

**Camgear (R.H.)**

If it is necessary to replace the camgear due to pitting of the teeth or breakage, it will be necessary to disassemble the unit completely as described in Steps 1 through 5 of case disassembly and in Steps 1 through 4 of Cam/Clutch service.

When replacing the camgear, it will be necessary to adjust (by selecting the correct shim) the camgear to pinion gear backlash using the following procedure:

1. Install the new camgear disc pack sub-assembly (as reassembled in Steps 1 through 5 of the Cam/Clutch service procedure into the R.H. case, making sure that all (6) ear guide clips are in their proper location.
2. Clamp the camgear disc pack sub-assembly firmly into the R.H. case disc pocket by bolting in place, (see Fig. 25) Place all (3) pinion gears and pinion

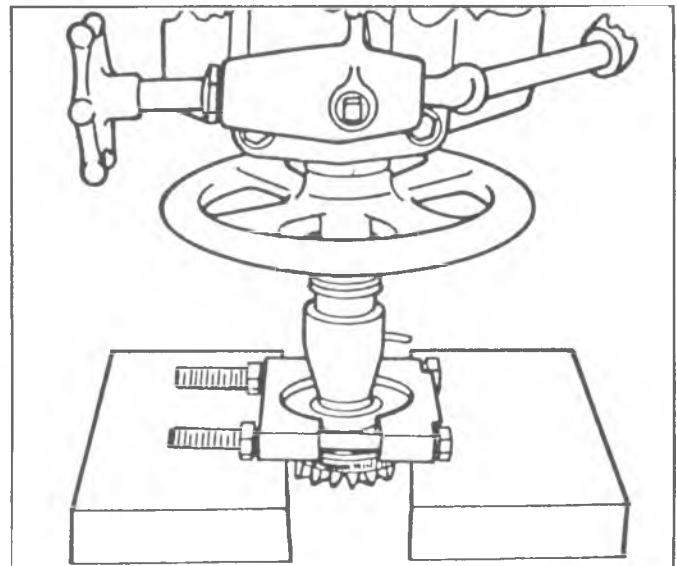

Fig. 24--Bearing Remover J-22919



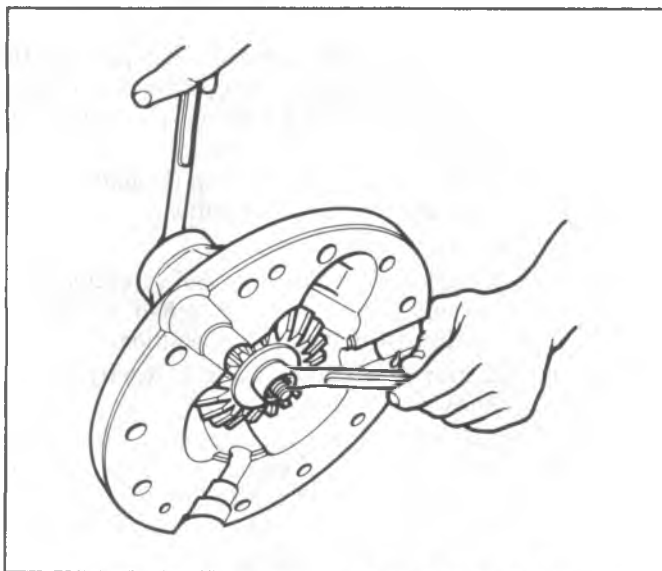

Fig. 25--Retaining Camgear Disc Pack in RH Case

thrust washers on the pinion yoke and firmly seat the yoke into position in the R.H. case (See Figure 26).

Slightly loosen the clamping bolt and index one pinion gear tooth so that it points downward perpendicular to the parting line of the R.H. case half, and retighten the clamping bolt.

- Using a dial indicator mounted to the case parting surface, measure pinion gear to camgear backlash by holding pinion gear firmly against its seat and gently rotating it back and forth, and note reading (See Fig. 27).

**NOTICE:** Take care not to unseat the pinion yoke or backlash reading will be inaccurate.

Repeat the above procedure of indexing and check backlash of the remaining (2) pinion gears, and note readings. If backlash is not between .010 and .018 on all gears, change shim size and repeat backlash procedure until the correct backlash is obtained. The thinner the shim used, the greater the backlash will be.

**NOTICE:** When camgear and/or side gear is replaced, thrust block replacement and clearance procedures must be followed during reassembly of the unit. Failure to do so may disturb critical clearances and could result in differential complaints.

## Side Gear

### Replacement

If it is necessary to replace the side gear due to pitting of the gear teeth, scoring of the hub, or breakage, it will be necessary to disassemble the unit as described in Steps 1 through 5 of case disassembly and in Steps 1 and 2 of side gear and clutch disc pack disassembly. When replacing the side gear, it will be necessary to adjust (by selecting the correct shim), the side gear to pinion gear backlash using the same procedure as described in the Camgear replacement procedure. However, backlash should be adjusted to within .002-.010.

## Thrust Block Replacement and Clearance

If it is necessary to replace the thrust blocks only, replace them with ones of identical thickness. If the thrust blocks are broken, check for other damage and replace parts as necessary. If either R.H. case or L.H. is damaged, replace the entire unit.

If the camgear (R.H.) and/or side gear (L.H.) is replaced, it will be necessary to check the side gear spread dimension and adjust block clearance as follows:

- Bolt the camgear (R.H.) disc pack sub-assembly and shim into the R.H. case as described in the Camgear Replacement procedure, and measure distance from the camgear face to the parting surface of the case and note the dimension (See Fig. 28).
- Bolt the side gear (L.H.) disc pack sub-assembly and shim into the L.H. case half in the same manner and measure the distance from the side gear face to the parting surface of the case and note the dimension. Adding these (2) dimensions together will equal side gear spread.

**NOTICE:** When adding these dimensions, be certain to subtract out the thickness of the straight-edge from both readings.

Now, measure the thickness of the original thrust blocks together (see Fig. 29). If the thickness of the thrust blocks together is not within a range of .000 to .006 less than the side gear spread, adjust clearance with one of the following procedures:

- Reshim L.H. clutch disc pack. Note: Backlash of .002-.010 must still be maintained.
- Select correct size thrust block(s) to obtain .000 to .006 clearance.

Once the proper thrust block clearance has been obtained, continue reassembly of case.

## CASE

### Reassembly

- Install (6) clutch pack guide clips on the ears of the camgear clutch pack using grease for retention.
- Install cam gear assembly and original shim in

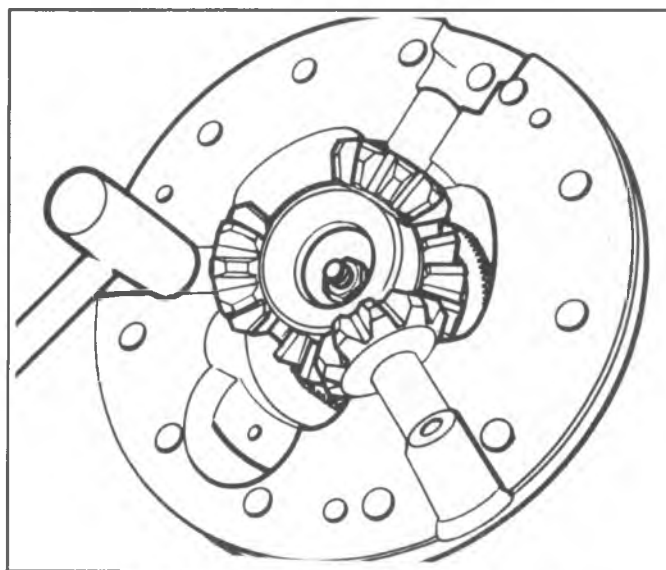

Fig. 26--Pinion Gears and Thrust Washers

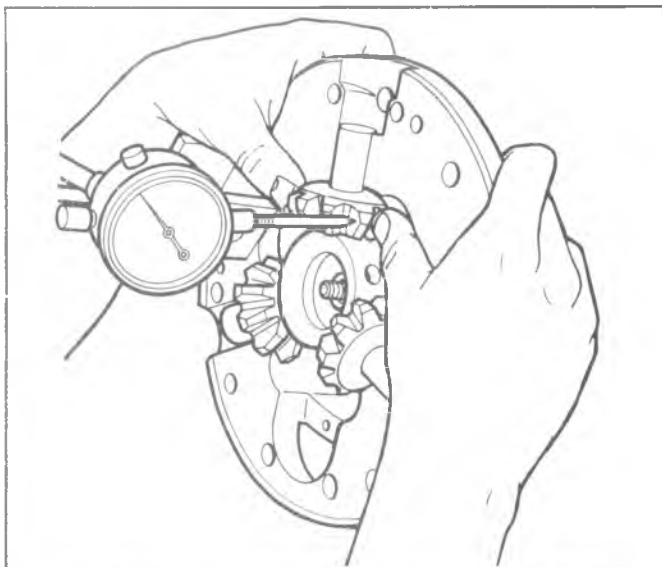

Fig. 27—Measuring Pinion Gear to Camgear Backlash

right side case half. If new camgear is installed, see Differential Gear Replacement Procedure. If a new thrust ring has been pressed on the cam gear, reshimming may be necessary. Measure the overall length of the new cam gear assembly, including the shim and compare to the dimension obtained in Step 1 of Cam/Clutch service procedure. If the length of the new assembly varies by more than .003" larger or smaller than the original dimension, reshimming will be necessary. Select a shim which will result in a reading closest to the original.

**NOTICE:** Incorrect shimming will disturb critical clearance dimensions and may result in differential complaints.

3. Install right side thrust block on gear face with button side of block facing up. Use original block unless severely scored or worn. If new block is used, determine face-to-face thickness of original block with calipers and replace with a service block of the same thickness.

**NOTICE:** Incorrect block thickness will disturb critical clearances and may result in differential failure.

4. Preassemble pinions and pinion thrust washers on pinion yoke. Index yoke to proper position and install in housing with center over button end of thrust block. A light tap on the yoke may be needed to seat it in the housing.
5. Install left side thrust block on the yoke with flange side up. Use original block unless severely scored or worn. If new block is used, determine face-to-face thickness of original block with calipers and replace with a service block of the same thickness.
6. Install governor assembly and latching bracket in their respective locations. Place straight end of latching bracket spring over and to the outside of the governor

shaft to preload the latching bracket against the governor assembly.

7. Install the (3) eared and (2) splined clutch plates on the L.H. side gear alternately, starting and ending with an eared disc. See Fig. 20. If new LH side gear is installed, see Differential Gear Replacement.
8. Install (6) clutch pack guide clips on the left side disc pack assembly using grease for retention.
9. Install shim in left side case half.
10. Remove disc pack from side gear and carefully lower disc pack assembly into left side case half. Make sure clutch guide clips are in their proper position.
11. Install side gear in left side case half. Rotate gear to engage spline with splines on discs.
12. Being careful not to dislodge side gear assembly (hold thumb on inside of side gear spline), lower the left hand case assembly onto the right hand case. Index left hand case so holes in housing will line up for the governor assembly and latching bracket shafts.
13. Turn entire unit over and install three (3) screws.
14. Lock an axle shaft in a vise in a vertical position. Install differential assembly on axle shaft engaging the spline of the axle with a side gear. Rotate unit slowly. A short shaft held in pinion yoke hole will aid in rotating. The unit should turn smoothly without binding or locking up.
15. Install ring gear and side bearings using the procedure outlined for standard differentials.
16. Place differential unit in carrier and adjust ring gear to pinion backlash and gear tooth pattern as outlined in the standard differential section.

**NOTICE:** Use only the rear axle lubricant recommended in Maintenance and Lubrication Section. The usage of any other lubricant or any additive may result in damage to the differential.

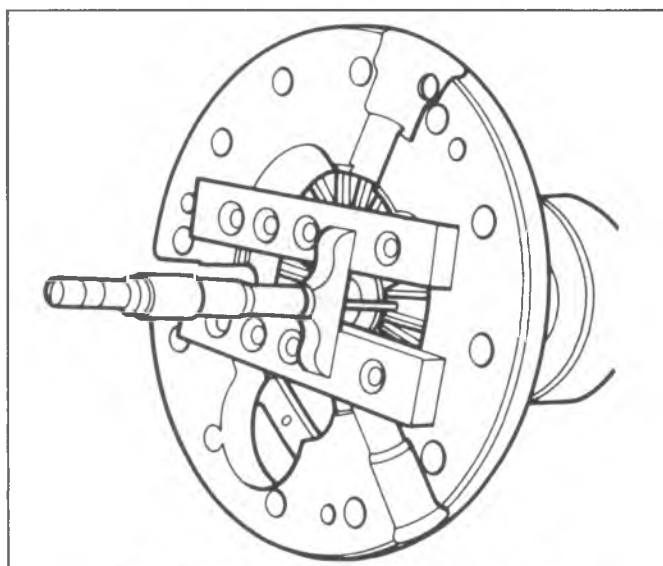

Fig. 28—Side Gear to Case Surface Depth



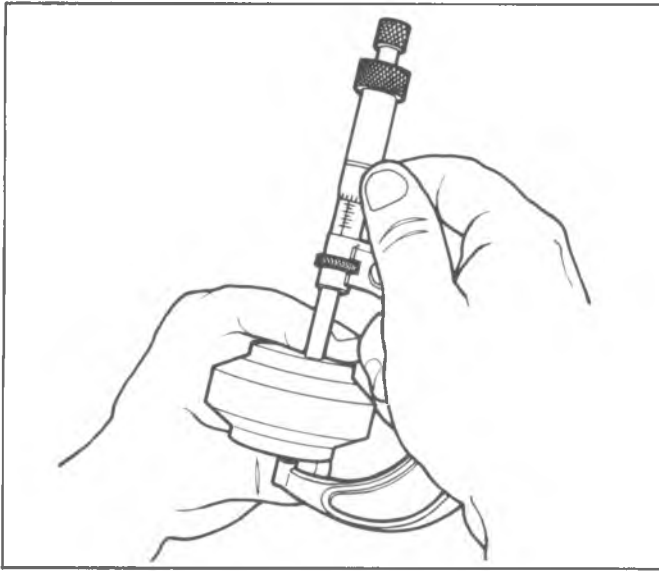
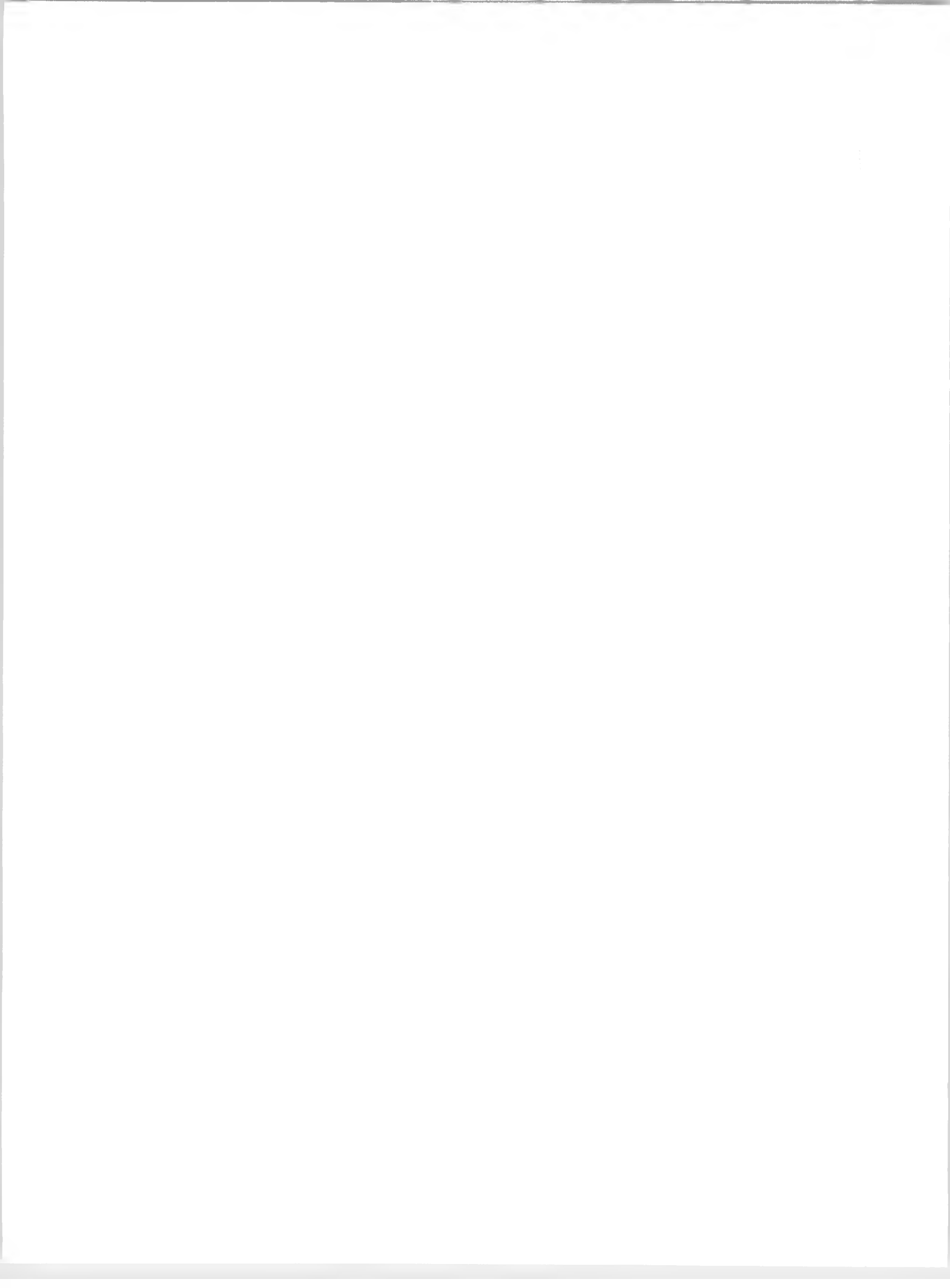

Fig. 29--Measuring Thrust Block



# SECTION 4B10

## SPECIFICATIONS AND SPECIAL TOOLS

### DIFFERENTIAL SPECIFICATIONS

|                                   | 8 1/2" Chevrolet | 9 1/2" Chevrolet | Dana<br>10 1/2"<br>9 3/4" | 10 1/2" Chevrolet | 12" Rockwell |
|-----------------------------------|------------------|------------------|---------------------------|-------------------|--------------|
| Gear Backlash Preferred           | .005"-.008"      | .005"-.008"      | .004"-.009"               | .005"-.008"       | .010         |
| Min. and Max.                     | .003"-.010"      | .003"-.010"      | .004"-.009"               | .003"-.012"       | .005-.015    |
| Pinion Bearing Preload (In.-Lbs.) |                  |                  |                           |                   |              |
| — New                             | 15-30            | 20-25            | 20-40                     | 25-35             | 5-15         |
| — Used                            | 5-10             | 5-15             | 10-20                     | 5-15              | —            |

#### BOLT TORQUES (FT.-LBS.)▲

|                           |    |     |     |     |   |
|---------------------------|----|-----|-----|-----|---|
| Carrier Cover             | 20 | 20  | 35  | 30  | — |
| Ring Gear                 | 80 | 110 | 110 | 120 | — |
| Differential Bearing Caps | 55 | 65  | 85  | 135 | — |

▲Except where noted otherwise

#### BOLT TORQUES (FT.-LBS.)▲

|                                      | 8 1/2" Chevrolet | 9 1/2" Chevrolet | Dana<br>10 1/2"<br>9 3/4" | 10 1/2" Chevrolet | 12# Rockwell |
|--------------------------------------|------------------|------------------|---------------------------|-------------------|--------------|
| Filler Plugs                         | 25               | 18               | 10                        | 18                | 35           |
| Differential Pinion Lock             | 20" #            | —                | —                         | —                 | —            |
| Drive Pinion Nut                     |                  | *                | *                         | *                 | 350          |
| Differential Carrier to Axle Housing |                  | —                | —                         | —                 | —            |
| Differential Bearing Adjusting Lock  |                  | 20               | —                         | 20                | 25           |
| Pinion Bearing Cage To Carrier       |                  | —                | —                         | 65                | 35           |
| Thrust Pad Lock Nut                  |                  | —                | —                         | —                 | —            |
| Brake Backing Plate                  | 35               | 105              | 105                       | 105               | —            |
| Axle Shaft To Hub Bolts              |                  | —                | 115                       | 115               | —            |

\*Torque as necessary to obtain correct preload

# Refer to Section 4B-5

| Ring Gear Size    | Lubricant Capacity |
|-------------------|--------------------|
| Chevrolet 8 1/2"  | 4.2 Pints          |
| Chevrolet 9 1/2"  | 5.5 Pints          |
| Chevrolet 10 1/2" | 5.4 Pints          |
| Dana 10 1/2"      | 7.2 Pints          |
| Dana 9 3/4"       | 6.0 Pints          |
| Rockwell 12"      | 14.0 Pints         |

### REAR WHEEL BEARING ADJUSTMENT SPECIFICATION

| RING GEAR SIZE | BEARING ADJUSTING NUT TORQUE* | ADJUSTING NUT BACK-OFF* | OUTER LOCKNUT TORQUE | RESULTING BEARING ADJUSTMENT | TYPE OF BEARING |
|----------------|-------------------------------|-------------------------|----------------------|------------------------------|-----------------|
| 10-1 1/2"      | 50 FT. LBS.                   |                         |                      | .001 TO .010 END PLAY        | TAPERED ROLLER  |
| 9-3/4"         | 50 FT. LBS.                   | **                      | 65 FT. LBS.          |                              |                 |
| 12             | 50 FT. LBS.                   | 1/8 *                   | 250 FT. LBS.         | .001 TO .010 END PLAY        | TAPERED ROLLER  |

\*\*Back-off nut and retighten to 35 Ft. Lbs. then, back-off nut 1/4 turn.

\*With wheel rotating.

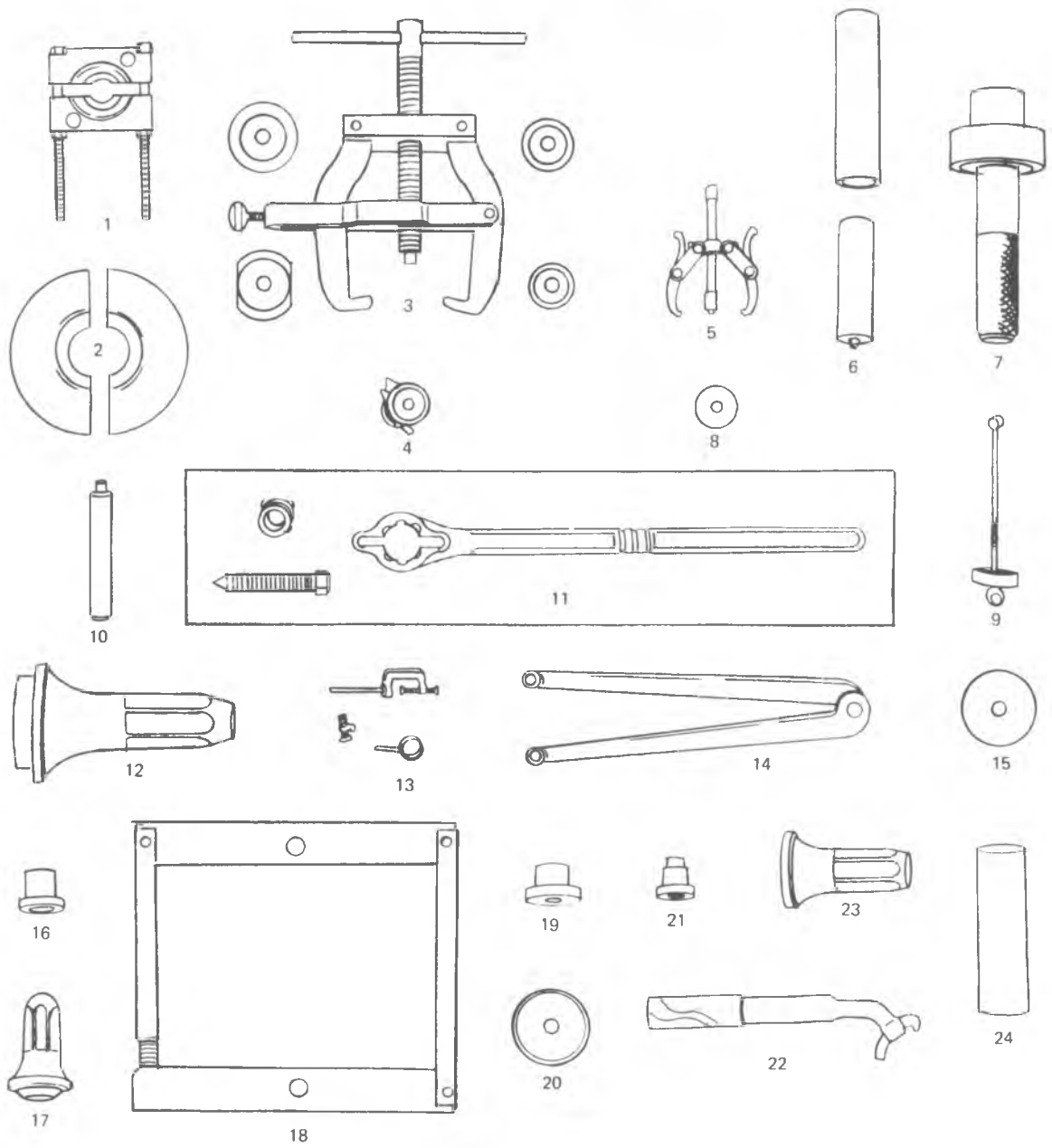

- |             |   |             |                                   |
|-------------|---|-------------|-----------------------------------|
| 1. J-22912  | Press Plate   | 13. J-8001  | Dial Indicator Set                |
| 2. J-1453   | Pinion Bearing Press Plate                                    | 14. J-0972  | Differential Nut Wrench           |
| 3. J-8107   | Differential Bearing Puller Set                               | 15. J-24381 | Pinion Rear Bearing Cup Installer |
| 4. J-8107-3 | Adapter Plug  | 16. J-24383 | Side Bearing Installer            |
| 5. J-22888  | Differential Side Bearing Remover                             | 17. J-24384 | Pinion Oil Seal Installer         |
| 6. J-1364   | Pinion Bearing Ring Drive                                     | 18. J-24385 | Case Spreader Tool                |
| 7. J-1488   | Differential Side Bearing Replacer                            | 19. J-24430 | Side Bearing Installer            |
| 8. J-8608   | Drive Pinion Rear Bearing Cup Installer<br>(Used with J-8092) | 20. J-24432 | Pinion Rear Cup Installer         |
| 9. J-5853   | In.-Lbs. Torque Wrench  | 21. J-23322 | Pinion Straddle Bearing Installer |
| 10. J-8092  | Drive Handle  | 22. J-24429 | Adjusting Nut Wrench              |
| 11. J-8614  | Companion Flange Holder and Remover                           | 23. J-24434 | Pinion Oil Seal Installer         |
| 12. J-22281 | Pinion Flange Oil Seal Installer                              | 24. J-24433 | Pinion Rear Bearing Installer     |

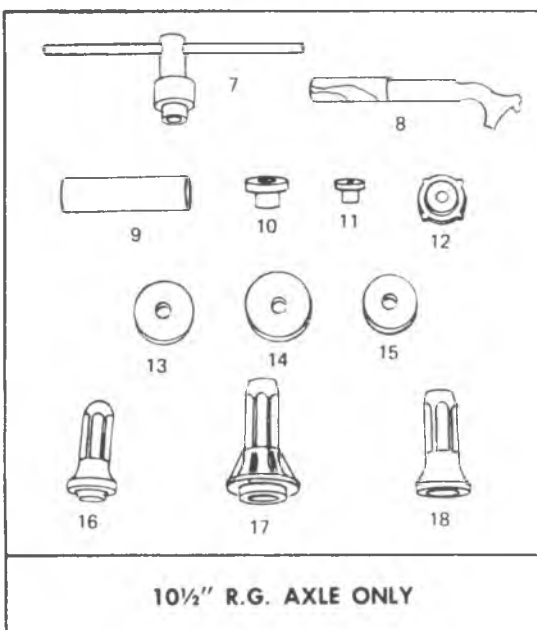
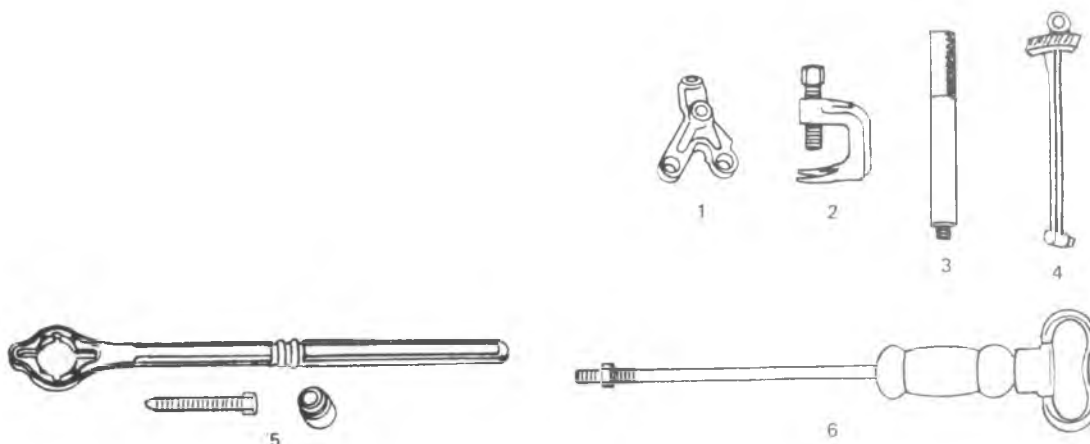

10 1/2" R.G. AXLE ONLY

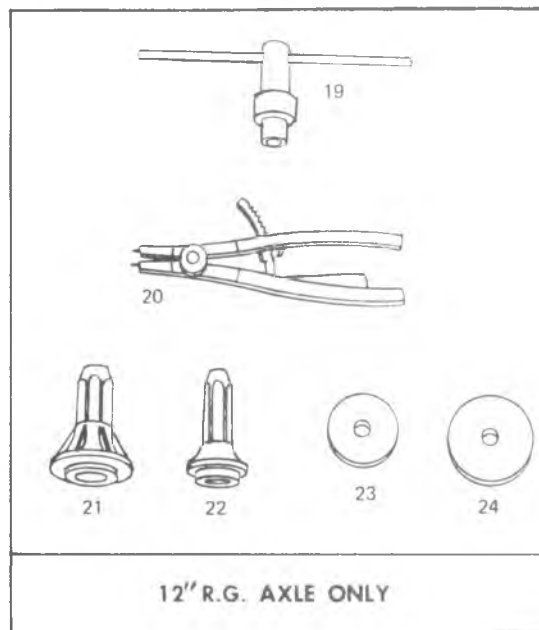

12" R.G. AXLE ONLY

- 1. J-5748 Positraction Torque Measuring Adapter
- 2. J-6627 Wheel Bolt Remover
- 3. J-8092 Driver Handle
- 4. J-5853 Torque Wrench - Inch/Pound
- 5. J-8614-II Companion Flange Holder
- 6. J-2619 Slide Hammer
- 7. J-2222 Wheel Bearing Nut Wrench
- 8. J-24429 Adjusting Nut Wrench
- 9. J-24433 Pinion Rear Bearing Installer
- 10. J-24430 Differential Side Bearing Installer
- 11. J-23322 Pinion Straddle Bearing Installer
- 12. J-24426 Outer Wheel Bearing Cup Tool
- 13. J-24432 Pinion Rear Bearing Cup Installer
- 14. J-24427 Inner Wheel Bearing Cup Installer
- 15. J-8608 Outer Wheel Bearing Cup Installer

- 16. J-24384 Pinion Oil Seal Installer - Dana
- 17. J-24428 Wheel Hub Oil Seal Installer
- 18. J-24434 Pinion Oil Seal Installer - Chevrolet
- 19. J-870 Wheel Bearing Nut Wrench
- 20. J-22380 Tru-Arc Pliers
- 21. J-22354 Wheel Oil Seal Installer
- 22. J-22281 Pinion Oil Seal Installer
- 23. J-8114 Wheel Bearing Outer Cup Installer
- 24. J-8093 Wheel Bearing Inner Cup Installer

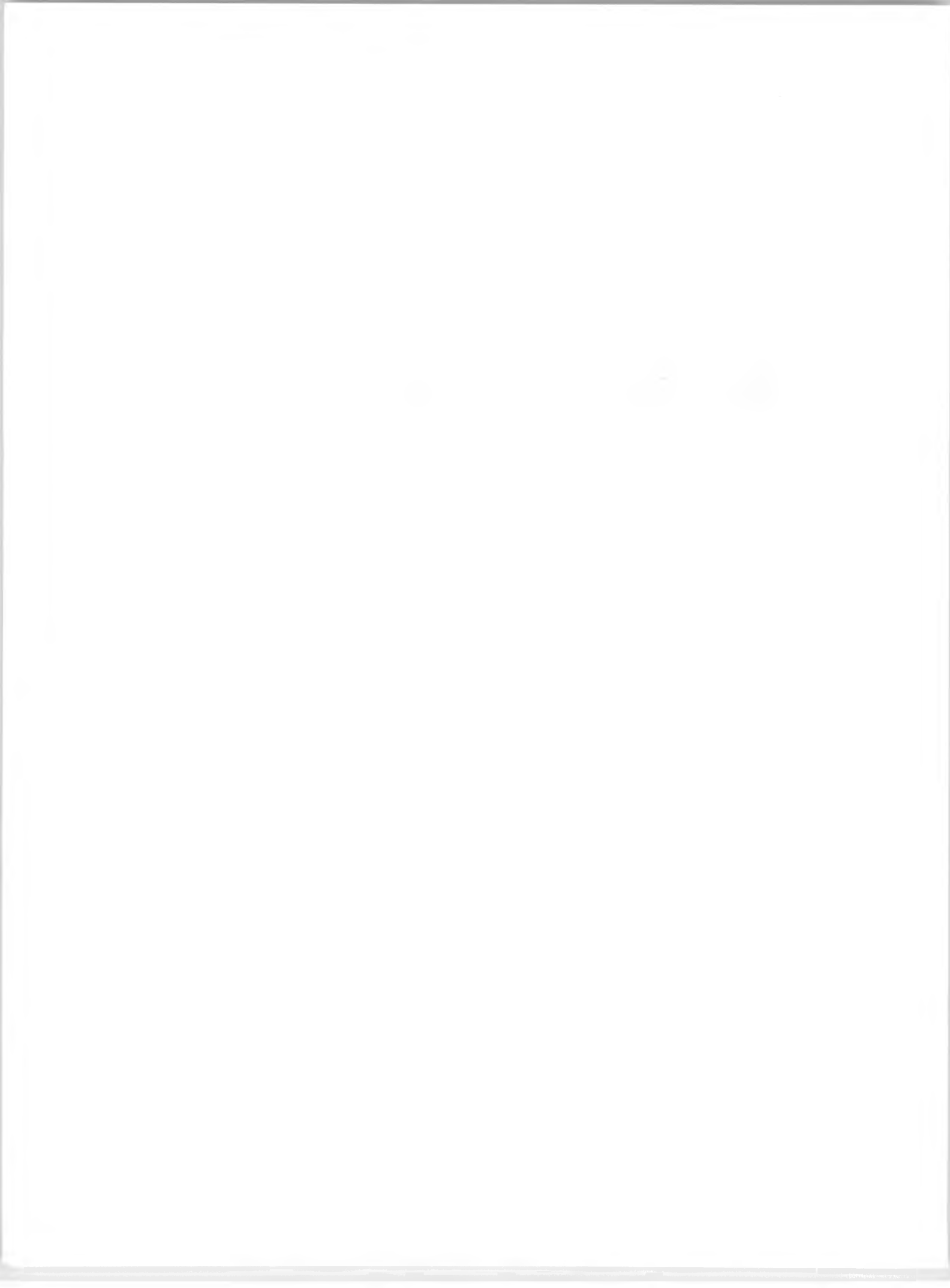

## SECTION 4C

# FRONT AXLE

The following notice applies to one or more steps in the assembly procedure of components in this portion of the manual as indicated at appropriate locations by the terminology "See Notice on page 1 of this Section".

**NOTICE:** This fastener is an important attaching part in that it could affect the performance of vital components and systems, and/or could result in major repair expense, it must be replaced with one of the same part number or with an equivalent part if replacement becomes necessary. Do not use a replacement part of lesser quality or substitute design. Torque values must be used as specified during reassembly to assure proper retention of this part.

### CONTENTS

|                                       |       |
|---------------------------------------|-------|
| General Description.....              | 4C-1  |
| Diagnosis.....                        | 4C-2  |
| Axle Shaft.....                       | 4C-1  |
| Front Axle Assembly.....              | 4C-2  |
| Removal.....                          | 4C-2  |
| Installation.....                     | 4C-3  |
| Repair Axle Joint Components.....     | 4C-4  |
| Unit Repair.....                      | 4C-4  |
| General Information.....              | 4C-4  |
| Differential Case.....                | 4C-4  |
| Removal.....                          | 4C-4  |
| Oil Seal Replacement.....             | 4C-5  |
| Disassembly.....                      | 4C-5  |
| Drive Pinion.....                     | 4C-5  |
| Removal.....                          | 4C-5  |
| Inspection.....                       | 4C-5  |
| Differential Case.....                | 4C-8  |
| Reassembly.....                       | 4C-8  |
| Drive Pinion.....                     | 4C-9  |
| Installation and Adjustment.....      | 4C-9  |
| Differential Case.....                | 4C-40 |
| Preload and Adjustment.....           | 4C-10 |
| Installation.....                     | 4C-10 |
| Gear Tooth Contact Pattern Check..... | 4C-10 |
| Gear Tooth Nomenclature.....          | 4C-11 |
| Special Tools.....                    | 4C-12 |
| Specifications.....                   | 4C-13 |

## GENERAL DESCRIPTION

The front axle is a hypoid gear axle unit equipped with steering knuckles. Axle assembly number and production date are stamped on left tube of assembly.

K10-20 Models use a Chevrolet front axle, both incorporate a 8-1/2" ring gear and have ratings of (K-10) 3600 lb. and (K-20) 3800 lb. The K-30 axle assembly is a Dana (60 Series) which incorporates a 9-3/4" ring gear and has a 4500 lb. capacity.

### Removal

1. Raise vehicle.
2. Remove wheel and tire.
3. Remove and support caliper. (See Notice on Page 1 of this section).  
Care should be taken so as not to stretch or damage the brake hose.
4. Remove hub lock mechanism.
5. Remove gears and snap rings.

| DIAGNOSIS                                      |  |
|--|--|
| EXCESS NOISE COMPLAINT<br>DIAGNOSTIC PROCEDURE |  |
| Road Test                                      | <ol style="list-style-type: none"> <li>1. Check tires for irregular wear</li> <li>2. Check tire pressure</li> <li>3. Check lubricant level</li> <li>4. Drive to warm-up front axle</li> <li>5. Test at various speeds in drive, float, coast and cornering</li> <li>6. Verify that hubs are locked</li> </ol>  |
| Tire Noises                                    | <ol style="list-style-type: none"> <li>1. Change tire pressure to minimize noises</li> <li>2. Drive over different road surfaces</li> <li>3. Smooth black-top minimizes tire noise</li> <li>4. Cross switch tires, if necessary</li> <li>5. Snow tire treads and studs cause added noises</li> </ol>   |
| Engine or Exhaust Noises                       | <ol style="list-style-type: none"> <li>1. Drive slightly above speed where noise occurs, place transmission in neutral</li> <li>2. Let engine speed drop to idle</li> <li>3. Stop vehicle</li> <li>4. Run engine at various speeds</li> </ol>  |
| Test for *Wheel Bearing Noise                  | <ol style="list-style-type: none"> <li>1. Drive vehicle at low speed on smooth road</li> <li>2. Turn vehicle to develop left and right motions, traffic permitting</li> <li>3. Noise should change due to cornering loads</li> <li>4. Jack-up wheels to verify roughness at wheels</li> </ol>  |
| Test for *Differential Bearing Noise           | <ol style="list-style-type: none"> <li>1. Drive vehicle at low speed on a smooth road</li> <li>2. Constant low pitch bearing noise may be heard</li> <li>3. Noise should not change in reversing turns</li> <li>4. Noise pattern should vary with wheel speed</li> </ol>   |
| Test for *Pinion Bearing Noise                 | <ol style="list-style-type: none"> <li>1. Roughness or whine noise should increase with speed</li> <li>2. Noise pitch should be higher than differentials</li> <li>3. Test on smooth road to minimize tire noises</li> <li>4. Test at various speeds in drive, float, and coast</li> <li>5. Rear pinion bearing noise may be louder on acceleration</li> <li>6. Front pinion bearing noise may be louder on deceleration</li> <li>7. Gear noises tend to peak in a narrow speed range</li> </ol> |

\*NOTE: Bearing tests should be done in 2H (after 4H selection to lock hubs). This removes transfer case whine.

101969

Fig. 4C-1--Bearing Diagnosis

6. Remove rotor.
7. Remove inner bearing and seal.
8. Remove spindle and backing plate.
9. Remove axle shaft.

### Installation

Prior to installation, the following items should be checked.

- a. Lube spindle bearing.
  - b. Clean, inspect and repack inner and outer wheel bearing.
  - c. Clean hub and spindle and lube spindle.
1. Install seal and thrust washer on axle shaft.
  2. Install axle shaft into axle housing.
  3. Install spindle.
  4. Install splash shield. Torque nuts to specifications.
  5. Install rotor and adjust wheel bearings.

6. Install thrust washer and snap ring.
7. Install hub lock mechanism.
8. Install caliper (See Notice on Page 1 of this section).  
Care should be taken so as not to stretch or damage the brake hose.
9. Install tire and wheel.
10. Lower vehicle.

### FRONT AXLE ASSEMBLY (Refer to Fig. 4C-2)

#### Removal

1. Raise front of vehicle until weight is removed from front springs. Support vehicle with jack stands behind front springs.
2. Disconnect propeller shaft from front axle differential.
3. Disconnect connecting rod from steering arm.
4. Remove and support caliper.
5. Disconnect shock absorbers from axle brackets.



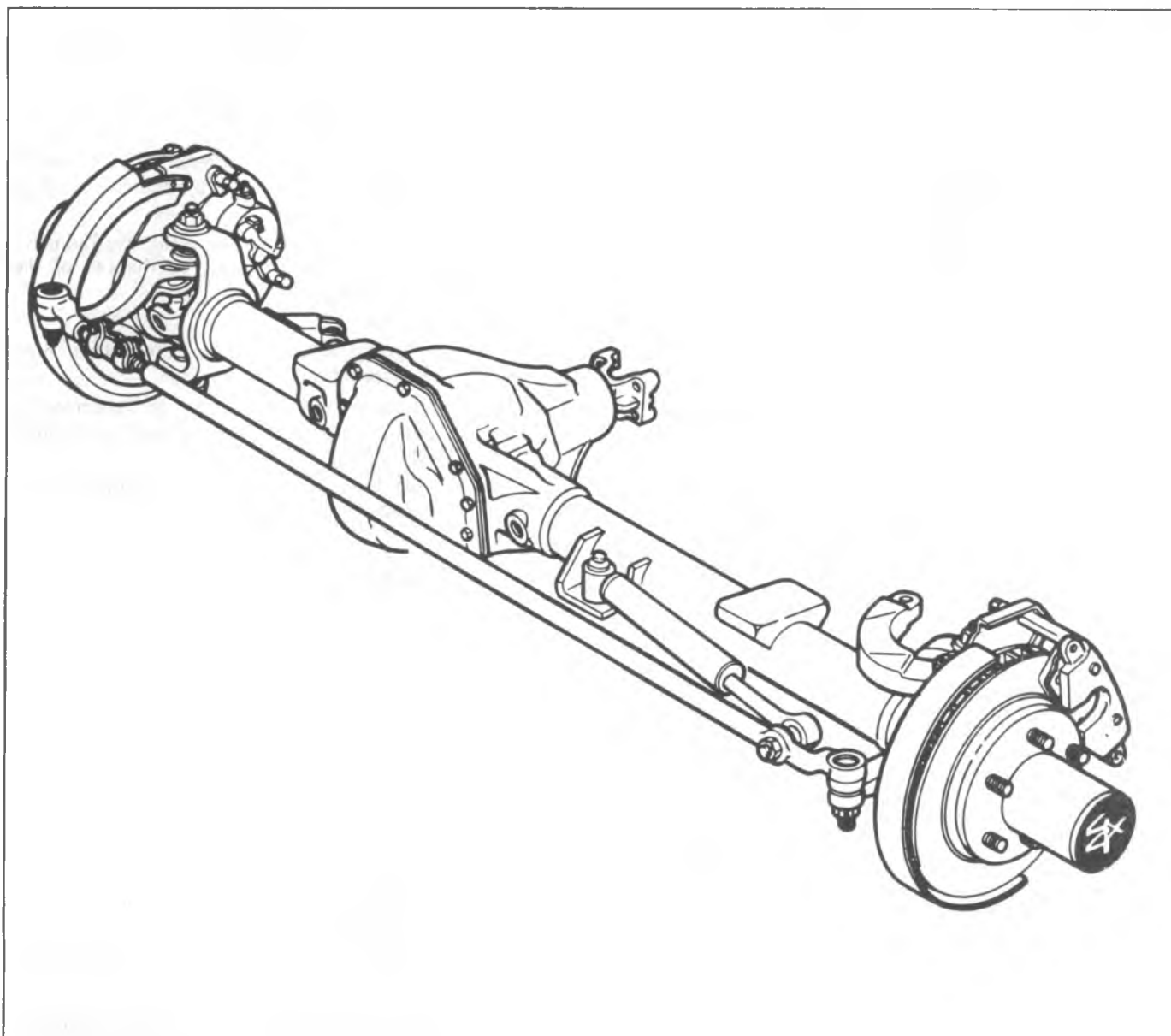

Fig. 4C-2--Front Drive Axle Typical

6. Disconnect axle vent tube clip at the differential housing (see fig. 4C-3).
7. Dismount "U" bolts from axle to separate axle from vehicle springs.
8. Raise vehicle to clear axle assembly and roll front axle out from under the vehicle.
6. Attach connecting rod to steering arm.
7. Remove jack stands and lower front of vehicle.
8. Assemble propeller shaft to front axle differential.
9. Lower vehicle to floor.

### Installation

**NOTICE:** See NOTICE on page 1 of this section regarding the fasteners referred to in steps 3, 5, 8 and 9.

1. Vehicle should be on jack stands as in Step 1 of removal instructions.
2. Place axle in position under vehicle.
3. Install "U" bolts attaching axle to front springs.
4. Attach shock absorbers to axle brackets.
5. Install caliper (Refer to Brake Section).

### Disassembly

Refer to Front Suspension Section for hub, spindle and knuckle removal and installation procedures.

1. Securely mount the axle assembly in a suitable holding fixture.
2. Remove automatic hub lock. (See Front Suspension Section).
3. Remove the wheel bearing outer lock nut, lock ring, and wheel bearing inner adjusting nut as outlined in Front Suspension Section.
4. Remove the disc assembly outer wheel bearing.

If the disc or other brake components require repairs or replacement, refer to Brake Section.

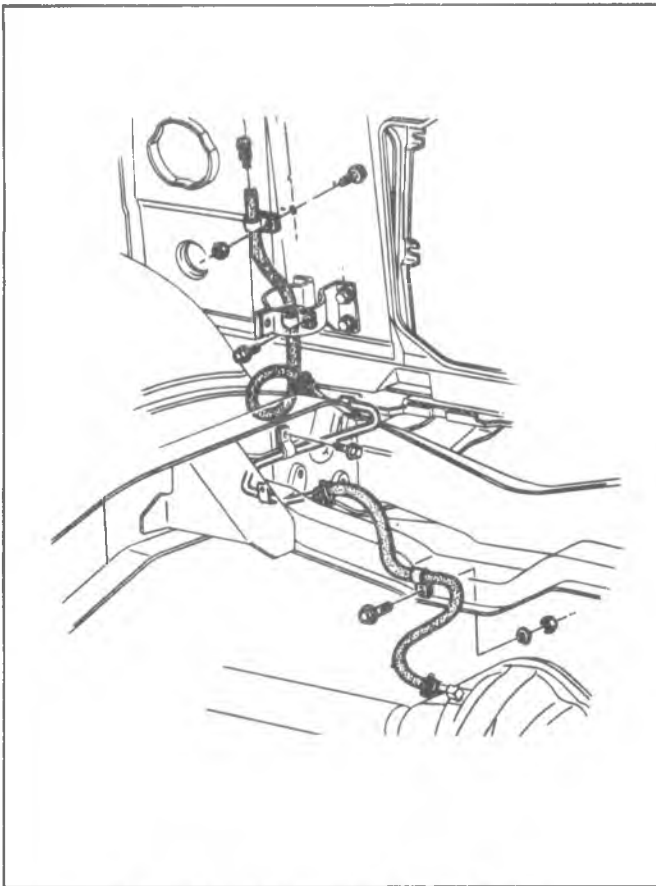

Fig. 4C-3--Axle Vent Hose Routing Typical

**Repair Of Axle Joint Components:**

1. Remove the lock rings after removing pressure from the trunnion bearings by squeezing the ends of the bearing in a vise.
2. Support the shaft yoke in a bench vise or on a short length of pipe.
3. Using a brass drift and a soft hammer, drive one end of one trunnion bearing just far enough to drive opposite bearing from yoke.
4. Support the other side of the yoke in the vise and drive the other bearing out by tapping on the end of the trunnion using a brass drift.
5. Remove trunnion.
6. Clean and inspect bearings. Lubricate with a high melting point type wheel bearing grease.
7. Replace trunnion and press new or relubricated bearings into yoke and over trunnion hubs far enough to install lock rings.
8. Hold trunnion in one hand and tap yoke lightly to seat bearings against lock rings.

**Assembly**

Reverse disassembly procedure.

## UNIT REPAIR

### GENERAL INFORMATION

The differential procedures in this section pertain to Dana model axles only. Procedures for the Chevrolet 8-1/2" model are the same as described in Section 4B.

### FRONT AXLE DIFFERENTIAL CASE

#### Removal (On Vehicle Dana Model) Fig. 4C-4

1. Raise front of vehicle until weight is removed from front springs.
2. Place jack stands under right hand and left hand frame rails.
3. Disconnect the right shock absorber at the axle.
4. Remove the U-bolt nuts.
5. Disconnect the tie rod at the right hand knuckle.
6. Place a jack stand under the right steering knuckle.
7. Lower the axle on stand, remove U-bolts and move spring aside.

**NOTICE:** Care should be taken so as not to stretch and damage the brake hose.

8. Turn stabilizer bar to spring plate attaching plate bolt and rotate the spring plate to provide clearance for the spreader tool, J-24385.

If front axle assembly is removed from vehicle, mount assembly in suitable holding fixture.

9. Remove axle shafts as outlined under Axle Shaft Removal.
10. Remove cover attaching bolts and lock washers and the metal tag secured by one of the attaching bolts. Remove cover and gasket.  
The tag shows the number of teeth on pinion and drive gear.
11. Remove differential side bearing caps, making sure they are marked for reassembly in the same position.
12. Position Spreader Tool J-24385 so the two dowels on tool fit into recesses in carrier, install two hold down bolts and install a dial indicator at one end of opening in carrier to indicate width of opening, (Fig. 4C-4 and 4C-5).
13. Expand spreader tool to spread carrier a maximum of .015".

**NOTICE:** Do not attempt to remove differential without using the spreader tool. Do not expand carrier more than .015 in. or it may be damaged and take a permanent set.

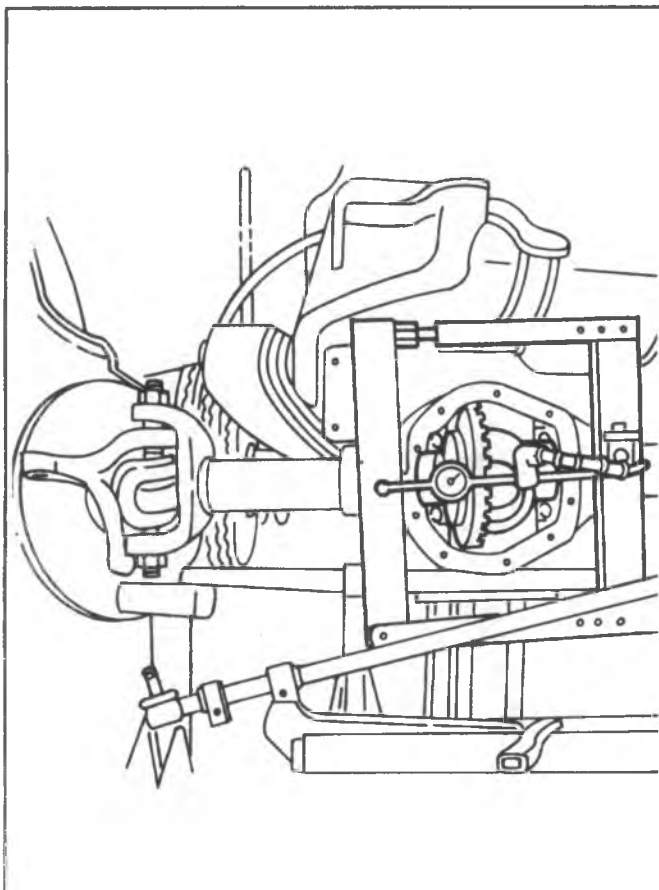

Fig. 4C-4--Removing Differential Case On Vehicle

14. Remove dial indicator and, using a pry bar, lift out differential assembly. Remove and tag bearing cups so they may be reinstalled in their original positions. Relieve pressure on spreader tool and remove tool.

#### Oil Seal Replacement

The axle shaft inner oil seals are located just outboard of the differential bearings, item 28 Fig. 4C-6. They can be replaced only after the differential is removed from the carrier, using tool J-28648.

#### Disassembly

1. Remove bearing cups from differential carrier and identify for reassembly.
2. Remove bearing cones from case, using puller J-29721 and correct plug (fig. 4C-8) and remove shims from case. Identify all parts so they may be reassembled in their original location.
3. Drive the pinion shaft lock pin out of case.
4. Remove ring gear bolts from case and separate ring gear from case.
5. Remove pinion shaft, pinions, side gears and thrust washers from case.

#### DRIVE PINION

##### Removal

1. Using Holding Bar J-8614-1, attached to pinion shaft flange, remove self-locking nut and washer from pinion shaft.

2. Install Tool J-8614-2, and 3 into holding bar as shown in Figure 4C-9 and remove flange from drive pinion. Remove drive pinion from carrier.
3. With a long drift, tap on inner race of outer pinion bearing to remove pinion oil seal, slinger gasket, outer pinion cone and roller and shim pack. Tag shim pack for reassembly.
4. Should inspection indicate necessity, pinion earring cups can be removed from carrier using a long drift and hammer. Remove shims and oil slinger which are located behind the inner bearing cup. Tag shims for reassembly.
5. Remove inner pinion cone and roller using Tool J-22912, installed as shown in Figure 4C-10, and press pinion from bearing.

#### Inspection

1. Clean all gears and bearings in cleaning solvent and inspect all bearing cups, races and rollers for scoring chipping or evidence of excessive wear. On pinion bearing rollers, inspect large end of rollers for wear. This is where wear is most evident on tapered roller bearings.

The pinion bearings are of the tapered type, and the natural wear pattern is a frosted condition with occasional slight scratches on races or rollers. This does not indicate a defective bearing.

2. Inspect pinion splines and flange splines for evidence of excessive wear.
3. Inspect ring gear and pinion teeth for possible scoring cracking or chipping.
4. Inspect differential case for cracks on scores or

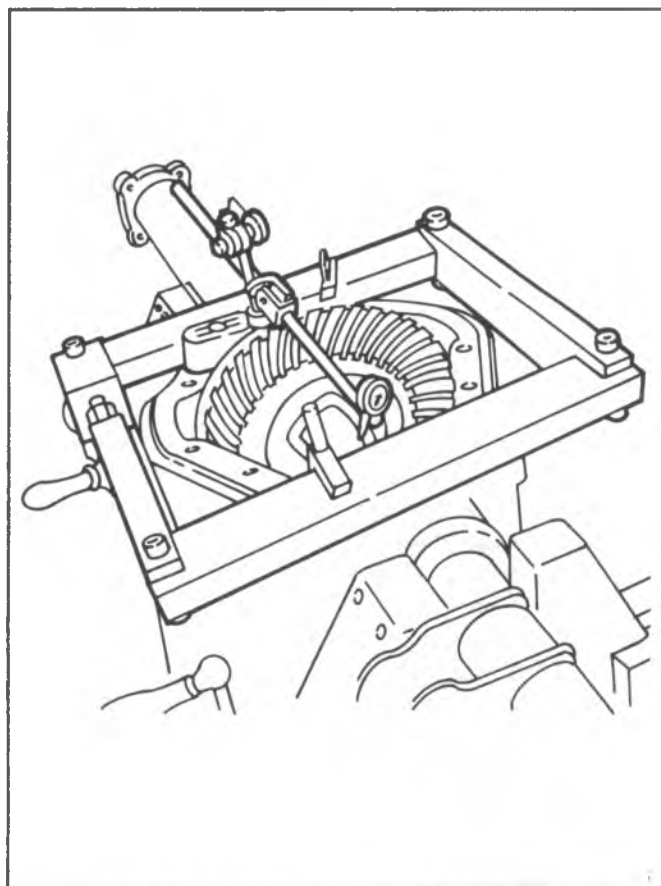
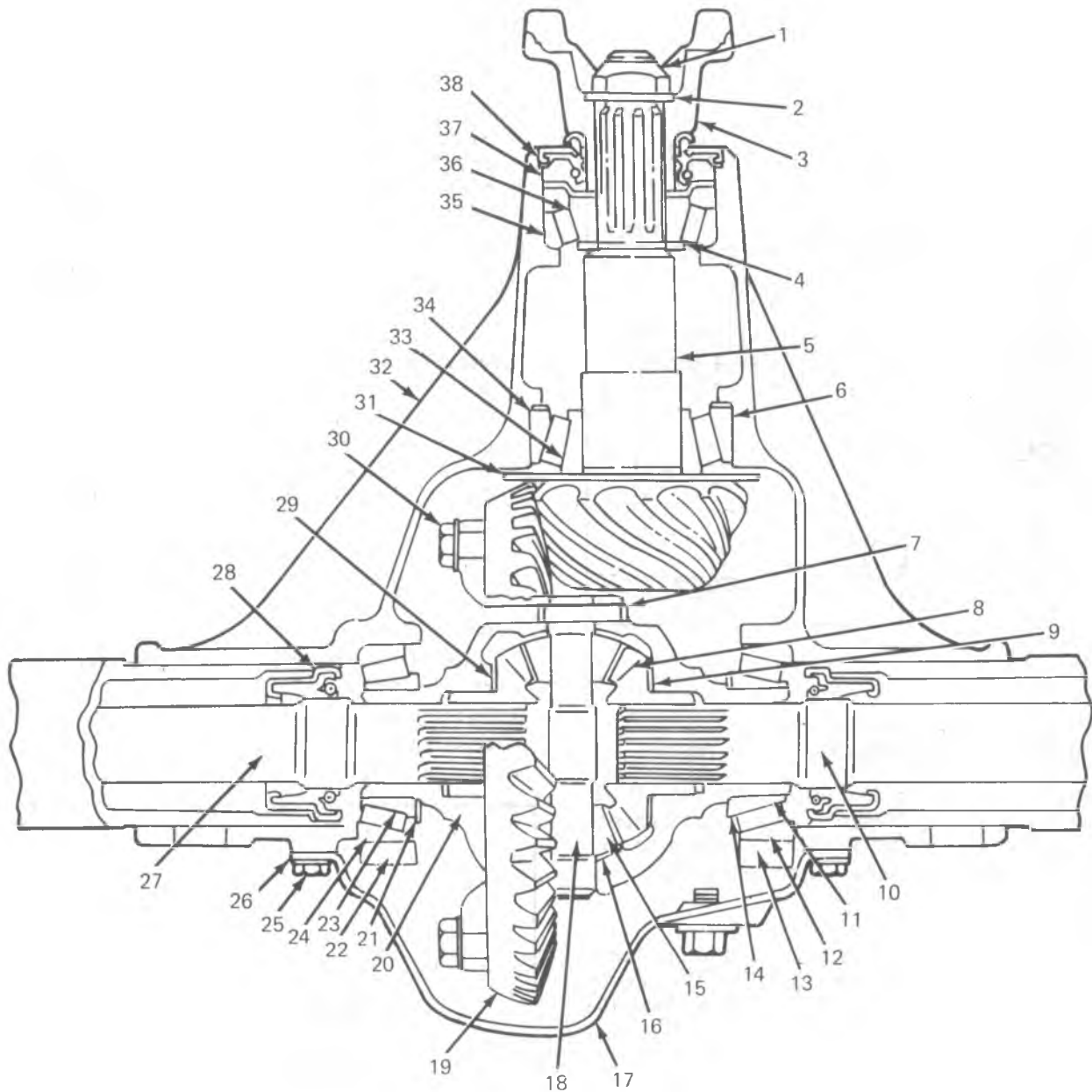

Fig. 4C-5--Spreading Case With J-24385



- |  |  |                          |
|--|--|--------------------------|
| 1. Nut                                   | 15. Differential Pinion                  | 29. Thrust Washer        |
| 2. Washer                                | 16. Thrust Washer                        | 30. Ring Gear Bolt       |
| 3. Pinion Flange                         | 17. Cover                                | 31. Oil Slinger          |
| 4. Outer Bearing Shims                   | 18. Pinion Cross Shaft                   | 32. Differential Carrier |
| 5. Drive Pinion                          | 19. Ring Gear                            | 33. Inner Bearing Cone   |
| 6. Inner Bearing Shims                   | 20. Differential Case                    | 34. Inner Bearing Cup    |
| 7. Lock Pin                              | 21. Differential Bearing Adjusting Shims | 35. Outer Bearing Cup    |
| 8. Differential Side Gear                | 22. Differential Bearing Cap             | 36. Outer Bearing Cone   |
| 9. Thrust Washer                         | 23. Differential Bearing Cone            | 37. Oil Slinger          |
| 10. Axle Shaft                           | 24. Differential Bearing Cup             | 38. Oil Seal             |
| 11. Differential Bearing Cone            | 25. Cover Bolt                           |                          |
| 12. Differential Bearing Cup             | 26. Gasket                               |                          |
| 13. Bearing Cap                          | 27. Axle Shaft                           |                          |
| 14. Differential Bearing Adjusting Shims | 28. Oil Seal                             |                          |

Fig. 4C-6--Front Axle Differential Assembly

Fig. 4C-7-Differential - Exploded View

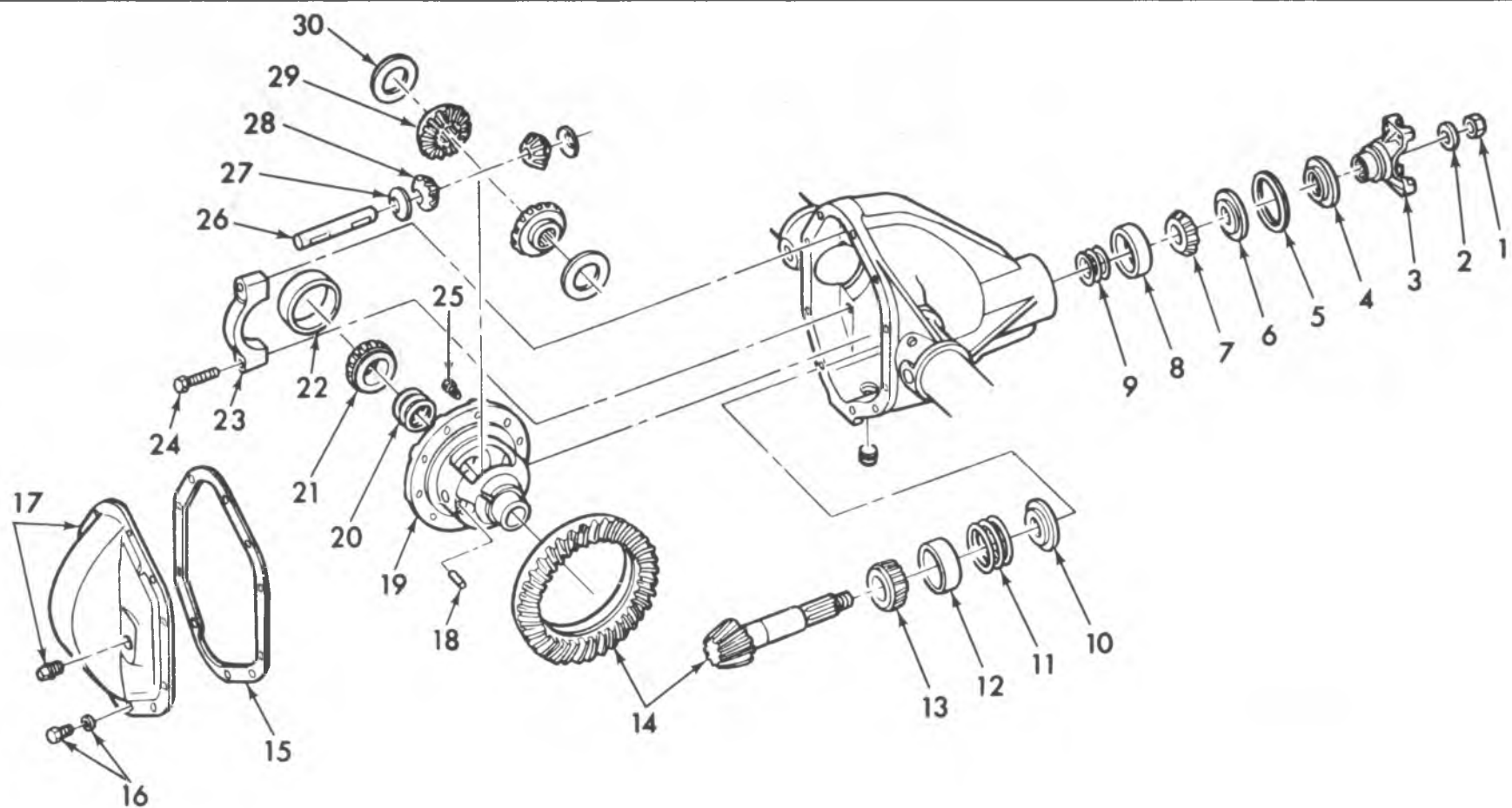

- |   |                                    |  |                                     |
|---|------------------------------------|--|-------------------------------------|
| 1. Nut  | 11. Shims (Inner Pinion Bearing)   | 17. Cover and Plug                         | 24. Bolt (Differential Bearing Cap) |
| 2. Washer                                       | 12. Cup (Inner Pinion Bearing)     | 18. Lock Pin (Pinion Shaft)                | 25. Bolt (Ring Gear)                |
| 3. Companion Flange                             | 13. Cone and Roller (Inner Pinion) | 19. Differential Case                      | 26. Pinion Shaft                    |
| 4. Pinion Oil Seal                              | 14. Ring and Pinion                | 20. Shims (Differential Adjusting)         | 27. Thrust Washer (Pinion)          |
| 5. Gasket                                       | 15. Gasket (Housing Cover)         | 21. Cone and Roller (Differential Bearing) | 28. Pinion                          |
| 6. Outer Pinion Oil Slinger                     | 16. Screw and Washer (Cover)       | 22. Cup (Differential Bearing)             | 29. Side Gear                       |
| 7 and 8. Cone and Roller (Outer Pinion Bearing) |                                    | 23. Cap (Differential Bearing)             | 30. Thrust Washer (Side Gear)       |
| 9. Shims (Outer Pinion Bearing)                 |                                    |  |                                     |
| 10. Inner Pinion Oil Slinger                    |                                    |  |                                     |

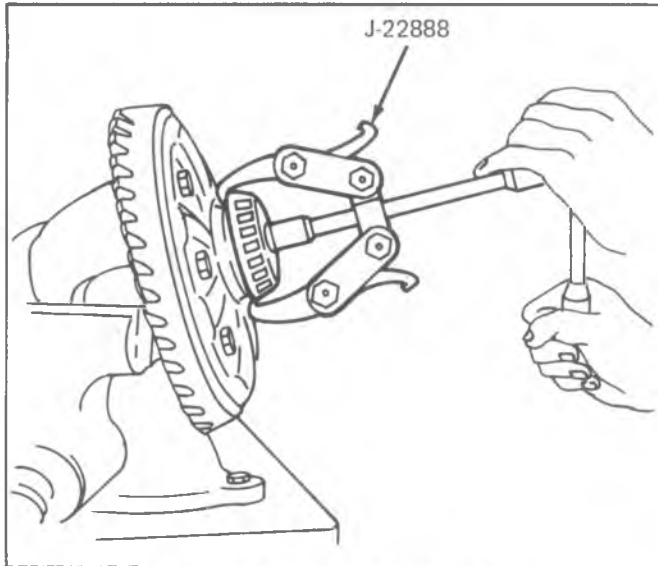

Fig. 4C-8--Removing Side Bearing

side gears, thrust washers, and pinion thrust faces.

5. Check fit of differential side gears in case.
6. Check fit of side gears and axle shaft splines.
7. Inspect differential pinion shaft and spacer for scoring or evidence of excessive wear.

### DIFFERENTIAL CASE

#### Reassembly

1. Position differential side gears and new thrust washers in differential case.
2. Position differential pinions and new thrust washers in differential case. Align pinions with holes in differential case.
3. Install pinion shaft in differential case. Align hole in shaft with hole in case, then install lock pin. Peen hole to prevent pin dropping out of case.
4. Position ring gear to case, then install cap screws. Tighten cap screws evenly and alternately to specifications.
5. With an arbor press, press differential side

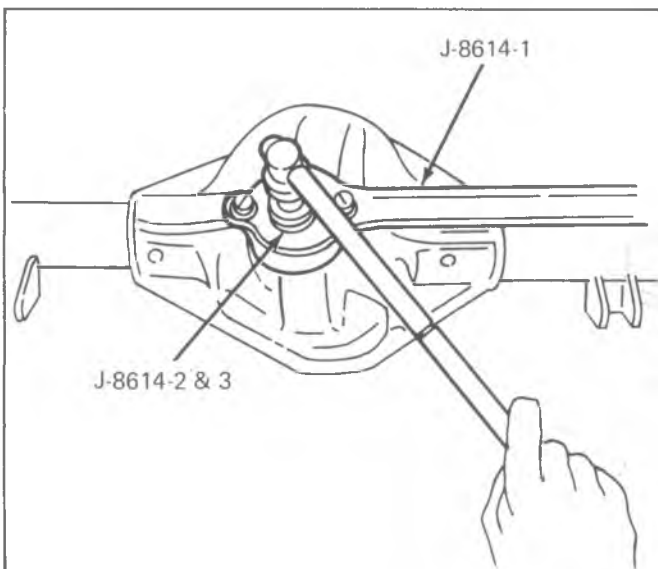

Fig. 4C-9--Removing Pinion Flange

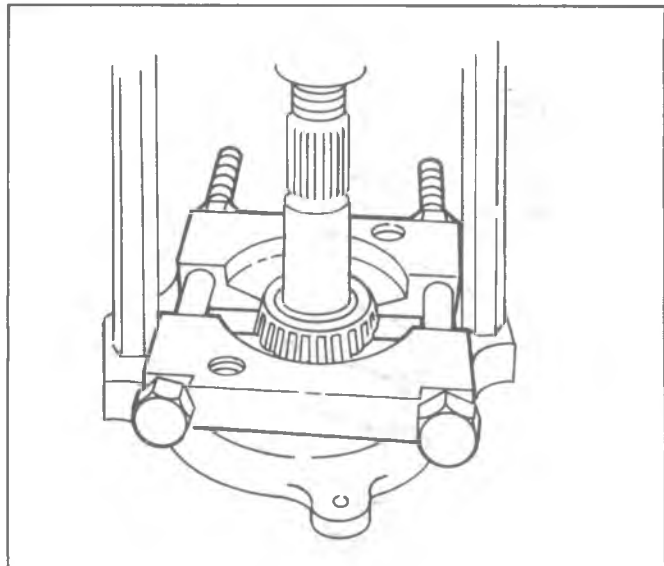

Fig. 4C-10--Removing Inner Pinion Bearing Cone and Roller

bearings onto case using Tool J-22175. Do not install shims at this time.

6. Place differential case in carrier and install bearing caps. Care should be taken to install caps in original position. Use mark placed on caps and carrier at removal. Tighten caps just enough to keep bearing caps in place.
7. Install dial indicator on carrier with indicator button contacting back of ring gear (Fig. 4C-11). Rotate differential case and check for runout. If runout is greater than .002", the assembly should be removed and the ring gear removed from case. Again install differential case and check runout at differential case flange.
8. Should runout of case flange be greater than .002", the defect is probably due to bearings or differential case, and should be corrected before proceeding further.
9. Position two screwdrivers between bearing cup and carrier on opposite side of ring gear (away from dial indicator side). Pull on screwdrivers and force

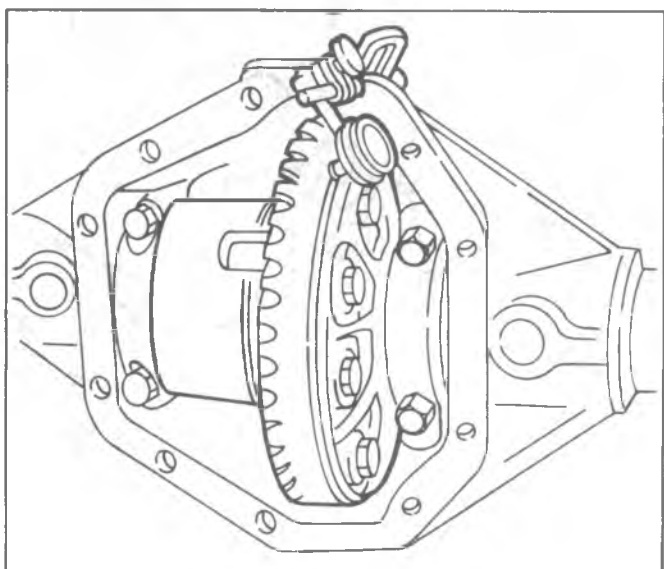

Fig. 4C-11--Checking Runout

| Old Pinion Marking | New Pinion Marking |         |         |         |         |         |         |         |         |
|--------------------|--------------------|---------|---------|---------|---------|---------|---------|---------|---------|
|                    | - 4                | - 3     | - 2     | - 1     | 0       | + 1     | + 2     | + 3     | + 4     |
| + 4                | + 0.008            | + 0.007 | + 0.006 | + 0.005 | + 0.004 | + 0.003 | + 0.002 | + 0.001 | 0       |
| + 3                | + 0.007            | + 0.006 | + 0.005 | + 0.004 | + 0.003 | + 0.002 | + 0.001 | 0       | - 0.001 |
| + 2                | + 0.006            | + 0.005 | + 0.004 | + 0.003 | + 0.002 | + 0.001 | 0       | - 0.001 | - 0.002 |
| + 1                | + 0.005            | + 0.004 | + 0.003 | + 0.002 | + 0.001 | 0       | - 0.001 | - 0.002 | - 0.003 |
| 0                  | + 0.004            | + 0.003 | + 0.002 | + 0.001 | 0       | - 0.001 | - 0.002 | - 0.003 | - 0.004 |
| - 1                | + 0.003            | + 0.002 | + 0.001 | 0       | - 0.001 | - 0.002 | - 0.003 | - 0.004 | - 0.005 |
| - 2                | + 0.002            | + 0.001 | 0       | - 0.001 | - 0.002 | - 0.003 | - 0.004 | - 0.005 | - 0.006 |
| - 3                | + 0.001            | 0       | - 0.001 | - 0.002 | - 0.003 | - 0.004 | - 0.005 | - 0.006 | - 0.007 |
| - 4                | 0                  | - 0.001 | - 0.002 | - 0.003 | - 0.004 | - 0.005 | - 0.006 | - 0.007 | - 0.008 |

Fig. 4C-12--Drive Pinion Shim Chart

differential case as far as possible toward the dial indicator. Rock the ring gear to set the bearings. With force still applied, set indicator at "0".

10. Reposition screwdrivers between bearing cup and carrier on ring gear side. Pull on screwdrivers and force differential case as far as possible toward center of carrier. Repeat several times until the same reading is obtained. Record the indicator reading. This will be the total amount of shims needed (less preload) for setting backlash later during assembly.
11. Remove differential from carrier.

## DRIVE PINION

### Installation and Adjustment of Depth and Preload

Ring gears and pinions are supplied in matched sets only. Matching numbers on both pinion and ring gear are etched for verification. If a new gear set is being used, verify the numbers of each pinion and ring before proceeding with assembly.

On the button end of each pinion there is etched a plus + number, a minus - number, or a zero(0) number, which indicates the best running position for each particular gear set. This dimension is controlled by the shimming behind the inner bearing cup. Whenever baffles or oil slingers are used, they become a part of the adjusting shim pack.

For example: If a pinion is etched +3, this pinion would require .003" less shims than a pinion etched "0". This means by removing shims, the mounting distance of the pinion is increased by .003" which is just what a +3 etching indicates. Or if a pinion is etched -3, we would want to add .003" more shims than would be required if the pinions were etched "0". By adding .003" shims, the mounting distance of the pinion was decreased .003" which is just what a -3 etching indicated.

If the old ring and pinion set is to be reused measure the old shim pack and build a new shim pack to this same dimension. If baffle is in the axle assembly, it is considered as part of the shim pack.

To change the pinion adjustment, shims are available in thicknesses of .003", .005" and .010".

If baffle or slinger is bent or mutilated, it should be replaced.

Measure each shim separately with a micrometer and add together to get total shim pack thickness from original build up.

If a new gear set is being used, notice the plus or minus etching on both the old and new pinion, and adjust the thickness of the old shim pack to compensate for the difference of these two figures.

For example: If the old pinion reads +2 and the new pinion is -2, add .004" shims to the original shim pack.

1. Determine proper inner shim pack (for setting pinion depth) by using chart (Fig. 4C-12).
2. Install inner shim pack and oil slinger in inner cup bore and drive inner cup into position using Tool J-21059 used with J-8092.
3. To the outer shim pack (for setting preload) add or remove an equal amount as was added or removed from the inner shim pack.
4. Install outer cup in carrier bore, using installer J-7818 with Drive Handle J-8092.
5. Press inner pinion bearing cone and roller onto pinion shaft using Installer J-9772 on arbor press as shown in Figure 4C-13.
6. Install drive pinion and inner bearing cone and roller assembly in differential carrier.
7. Install shims and outer pinion cone and roller on pinion shaft using Tool J-5590 and companion flange to press bearing onto pinion (Fig. 4C-14).
8. Install flange holding bar and install washer and nut on pinion shaft. Torque nut to 355 N·m (255 ft. lbs.).
9. Remove holding bar and with an inch pound torque wrench measure rotating torque. Rotating torque should be 1.2 to 2.2 N·m (10 to 20 in. lbs.) with original bearings or 2.2 to 4.6 N·m (20 to 40 in. lb.) with new bearings.  
Torque reading to start shaft turning must be disregarded.
10. If torque requirements (preload) are not to specifications, adjust shim pack as necessary R

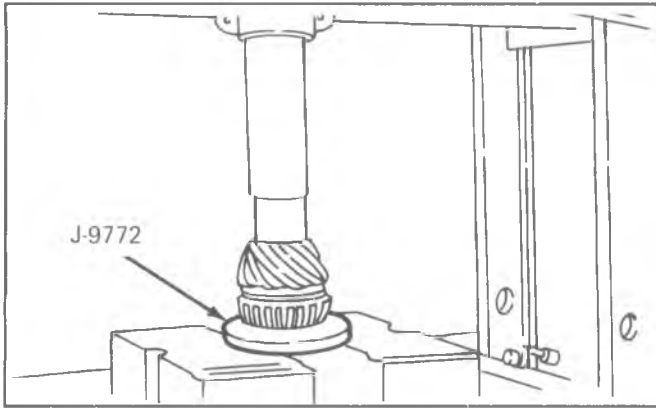

Fig. 4C-13--Installing Inner Pinion Core and Roller

Increase the outer shim pack to reduce rotation torque.  
Decrease shim pack to increase rotating torque.

11. Remove nut, washer and flange from pinion shaft.
12. Install oil slinger, gasket and using Tool J-22804 install oil seal.
13. Install flange, washer and nut. Torque nut to specifications.

## DIFFERENTIAL CASE

### Preload and Adjustment

1. Place differential assembly (with pinion assembled) into housing. Install bearing caps in their proper position and tighten screws just enough to hold the bearing caps in place.
2. Install dial indicator on carrier with indicator button contacting back of ring gear (Fig. 4C-11).
3. Place two screwdrivers between bearing cup and housing on ring gear side of case, and pry ring gear into mesh with pinion gear as far as it will go. Rock ring gear to allow bearings to seat and gears to mesh. With force still applied, set indicator to "0".
4. Reposition screw drivers on opposite side of ring gear and pry ring gear as far as it will go. Now take and indicator reading. Repeat until the same reading is obtained every time. This reading will be the necessary amount of shims between the differential case and differential bearing on the ring gear side. Remove differential bearing from the ring gear side and assemble proper amount of shims. Reassemble bearing.
5. Remove the differential bearing from the opposite side of ring gear. To determine the amount of shims needed here, use the following method.
  - a. Subtract the size of shim pack just installed on ring gear side of case from the reading obtained and recorded in step 10 of Differential Case Reassembly.
  - b. To this figure, add an additional .015" shims to compensate for preload and backlash.

Example: If reading in step 10 of Differential Case-Reassembly was .085" and the shims installed on ring gear side of case was .055", the correct amount of shim will be  $.085" - .055" + .015" = .045"$ .

6. Install shims as indicated in step 5, (which will give the proper bearing preload and backlash) and install side bearing.

### Installation

1. Spread differential carrier, using spreader as shown in Figure 4C-4 and 4C-5.
2. Install differential bearing cups in their correct locations then install differential case into carrier.
3. Install differential bearing caps in the correct location as indicated by marks made at disassembly. Install cap screws finger tight. Rotate differential assembly and rap on case with a soft-faced hammer to ensure proper seating of case in carrier.
4. Remove spreader and torque cap bolts to specifications.
5. Install dial indicator and check ring gear backlash at four equally spaced points around the ring gear. Backlash must be held to .004" to .009" and must not vary more than .002" between positions checked.
6. Whenever backlash is not within limits, differential bearing shim pack should be corrected to bring backlash within limits.
7. Check gear tooth contact as described in "Gear Tooth Contact Pattern Check".
8. After a successful pattern check, install housing cover using a new gasket.
9. Install axle shafts and install axle assembly into vehicle.
10. Fill with recommended lubricant, lower vehicle to floor and road test vehicle.

### GEAR TOOTH CONTACT PATTERN CHECK

Prior to final assembly of the differential, a Gear Tooth Contact Pattern Check is necessary to verify the correct relationship between ring gear and drive pinion. Gear sets which are not positioned properly may be noisy, or have short life, or both. With a pattern check, the most desirable contact between ring gear and drive pinion for low noise level and long life can be assured.

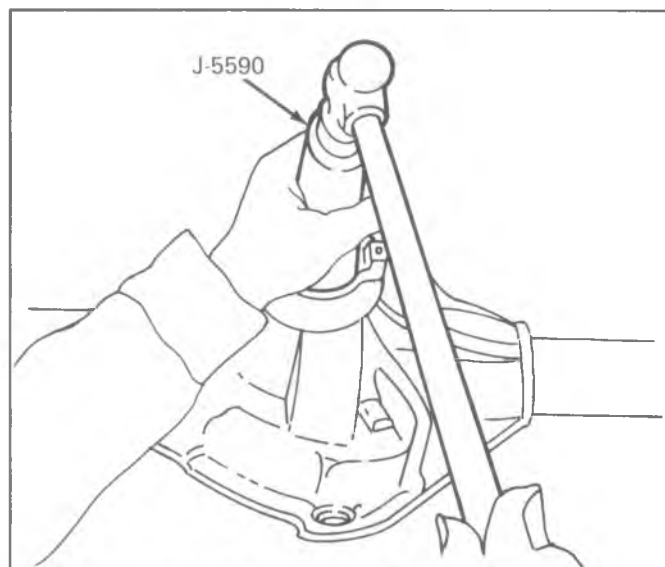

Fig. 4C-14--Installing Pinion Flange



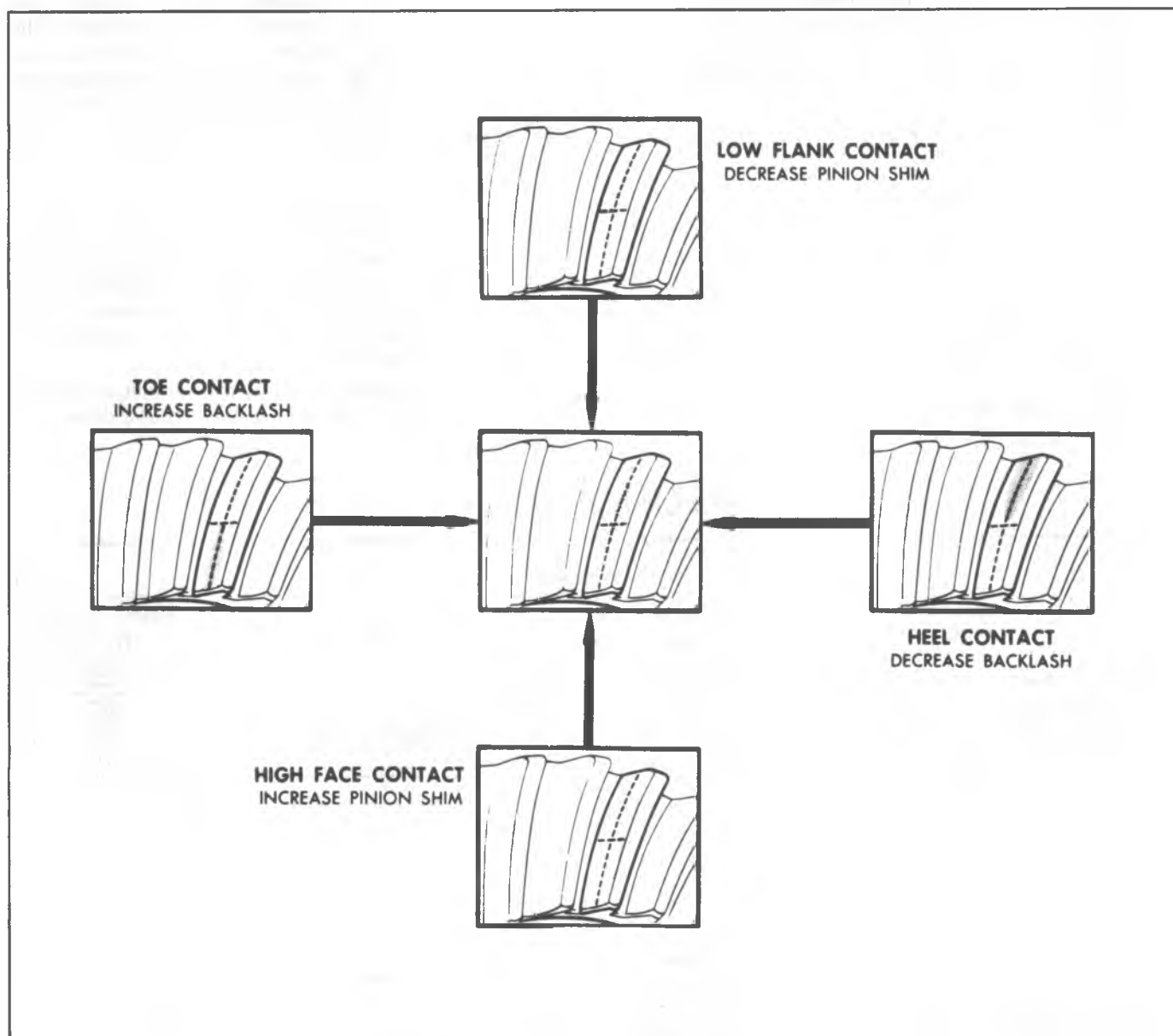

Fig. 4C-16--Gear Tooth Pattern Contact Pattern

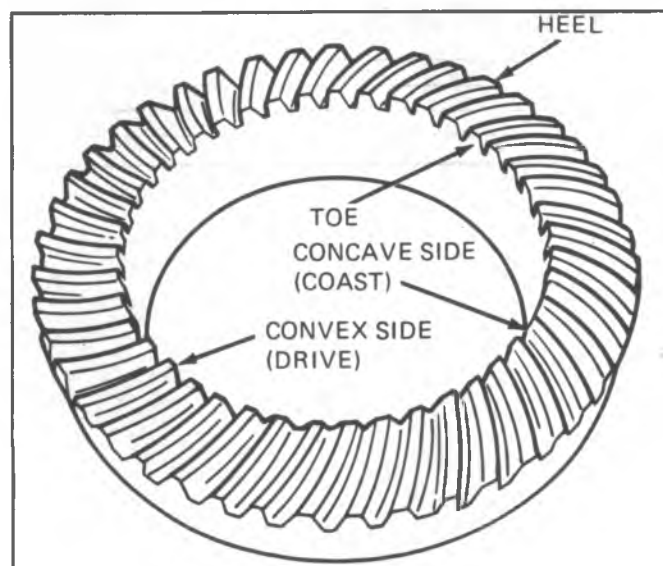

Fig. 4C-15--Gear Tooth Nomenclature

### Gear Tooth Nomenclature

The side of the ring gear tooth which curves outward, or is convex, is referred to as the "drive" side. The concave side is the "coast" side. The end of the tooth nearest center of ring gear is referred to as the "toe" end. The end of the tooth farthest away from center is the "heel" end. Toe end of tooth is smaller than heel end. See Figure 4C-15.

### Test

1. Wipe oil out of carrier and carefully clean each tooth of ring gear.
2. Use gear marking compound and apply this mixture sparingly to all ring gear teeth using a medium stiff brush. When properly used, the area of pinion tooth contact will be visible when hand load is applied.
3. Tighten bearing cap bolts to 75 N·m (55 lb. ft.).
4. Apply a load until a torque of 54-70 N·m (40-50 lb. ft.) is required to turn the pinion.

A test made without loading the gears will not give a

satisfactory pattern. Turn companion flange with wrench so that ring gear rotates one full revolution then reverse rotation so that ring gear rotates one revolution in opposite direction. Excessive turning of ring gear is not recommended.

5. Observe pattern on ring gear teeth and compare with Figure 4C-16.

#### Adjustments Affecting Tooth Contact

Two adjustments can be made which will affect tooth contact pattern. These are backlash and position of drive pinion in carrier. The effects of bearing preloads are not readily apparent on hand loaded teeth pattern tests; however, these adjustments should be within specifications before proceeding with backlash and drive pinion adjustments.

It may be necessary to adjust both pinion depth and backlash to obtain the correct pattern.

The position of the drive pinion is adjusted by increasing or decreasing the shim thickness between the pinion head and inner race of rear bearing. The shim is used in the differential to compensate for manufacturing tolerances. Increasing shim thickness will move the pinion closer to centerline of the ring gear. Decreasing shim thickness will move pinion farther away from centerline of the ring gear.

Backlash is adjusted by means of the side bearing adjusting shims which moves the entire case and ring gear assembly closer to, or farther from the drive pinion. (The adjusting shims are also used to set side bearing preload). To increase backlash, increase right shim and decrease left shim an equal amount. To decrease backlash decrease right shim and increase left shim an equal amount.

The important thing to note is that the contact pattern is centrally located up and down on the face of the ring gear teeth.

## SPECIFICATIONS

### CHEVROLET

| Axle                        | Bolt Torques (Ft.-Lbs.) | Axle                      | Bolt Torques (Ft.-Lbs.) |
|-----------------------------|-------------------------|---------------------------|-------------------------|
| Gear and Backlash Preferred | .005-.008               | Carrier Cover             | 20                      |
| Min. and Max.               | .003-.010               | Ring Gear                 | 80                      |
| New Pinion Bearing Preload  | 15-30 in.-lbs.          | Differential Bearing Caps | 55                      |
| Used Pinion Bearing Preload | 5-10 in.-lbs.           | Filler Plugs              | 25                      |
|                             |                         |                           |                         |
|                             |                         |                           |                         |

### DANA

| Axle                        | Bolt Torques (Ft.-Lbs.) | Axle                      | Bolt Torques (Ft.-Lbs.) |
|-----------------------------|-------------------------|---------------------------|-------------------------|
| Gear Backlash Preferred     | .004"-.009"             | Carrier Cover             | 35                      |
| Min. and Max.               | .004"-.009"             | Ring Gear* — K-30         | 110                     |
| New Pinion Bearing Preload  | 20-40 in.-lbs.          | Differential Bearing Caps | 85                      |
| Used Pinion Bearing Preload | 10-20 in.-lbs.          | Filler Plugs              | 10                      |
|                             |                         | Drive Pinion Nut** — K-30 | 270                     |
|                             |                         |                           |                         |
|                             |                         |                           |                         |
|                             |                         |                           |                         |

Specification Chart 4C-1

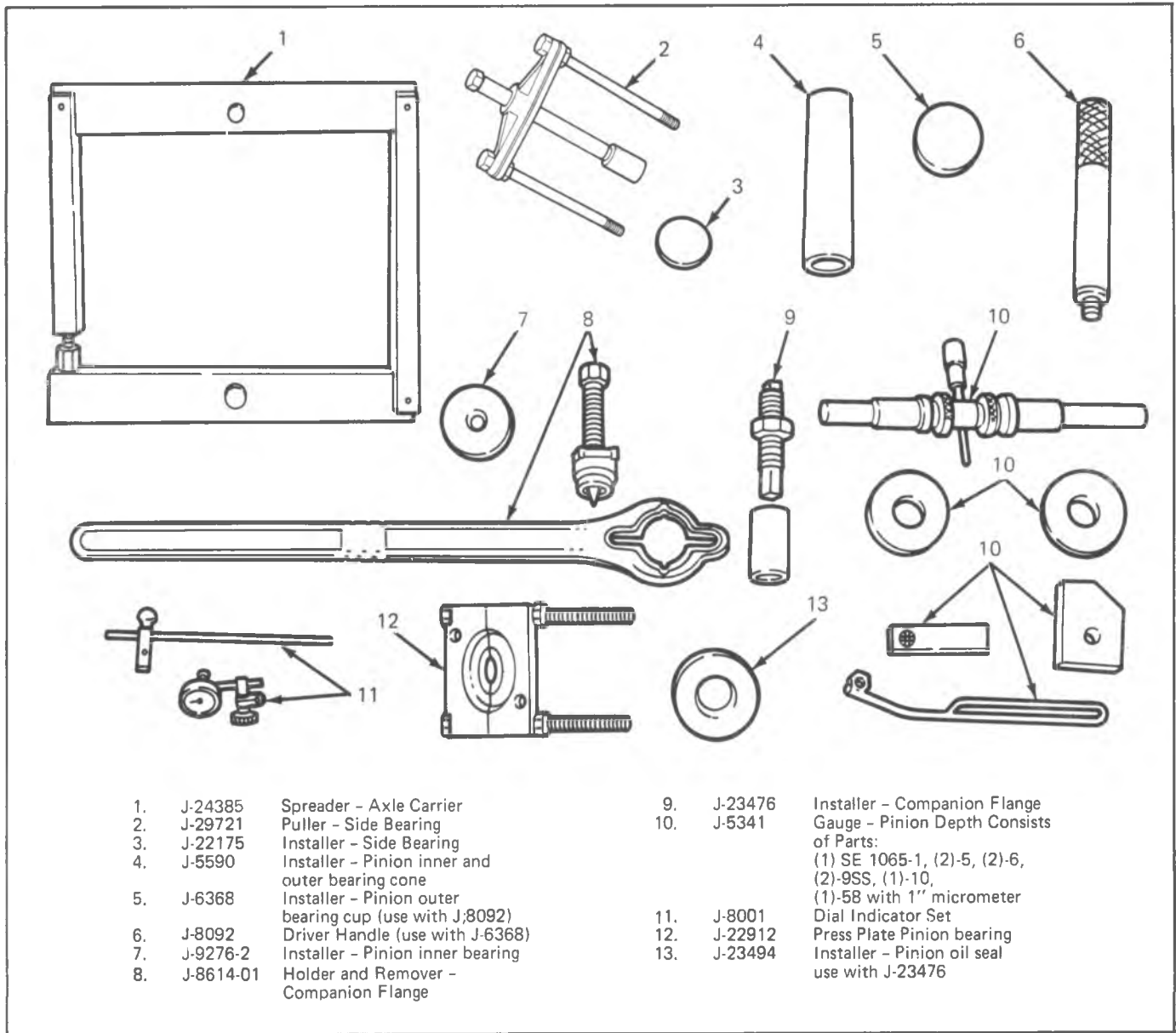
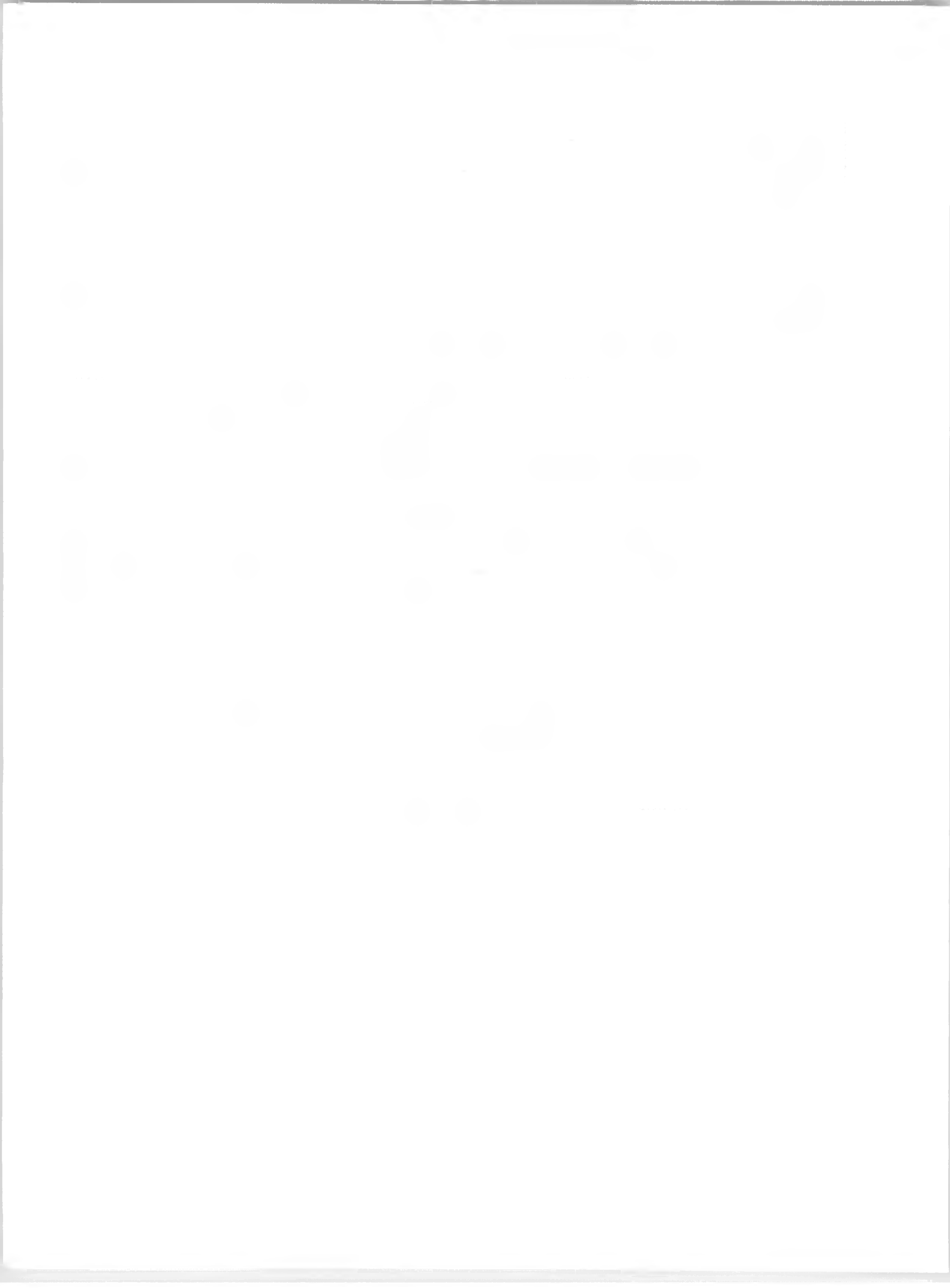

Fig. 4C-17--Special Tools



## SECTION 5

# BRAKES

The following notice applies to one or more steps in the assembly procedure of components in this portion of the manual as indicated at appropriate locations by the terminology "See Notice on Page 1 of this section".

**NOTICE:** This fastener is an important attaching part in that it could affect the performance of vital components and system, and/or could result in major repair expense. It must be replaced with one of the same part number or with an equivalent part if replacement becomes necessary. Do not use a replacement part of lesser quality or substitute design. Torque values must be used as specified during reassembly to assure proper retention of this part.

**CAUTION:** When servicing wheel brake parts, do not create dust by grinding or sanding brake linings or by cleaning wheel brake parts with a dry brush or with compressed air. (A water dampened cloth should be used.) Many wheel brake parts contain asbestos fibers which can become airborne if dust is created during servicing. Breathing dust containing asbestos fibers may cause serious bodily harm.

### CONTENTS

|   |      |                                       |      |
|---|------|---------------------------------------|------|
| General Information .....                             | 5-1  | Delco Brake Systems .....             | 5-31 |
| Diagnosis .....                                       | 5-1  | Delco Caliper 3000/3100 Series .....  | 5-32 |
| General Information and Service .....                 | 5-4  | Delco Composite Master Cylinder ..... | 5-36 |
| Pedal Travel .....                                    | 5-4  | Delco Cast Iron Master Cylinder ..... | 5-38 |
| Brake Pedal .....                                     | 5-4  | Power Head, Single Diaphragm .....    | 5-41 |
| Brake Pedal Rod .....                                 | 5-4  | Power Head, Tandem Diaphragm .....    | 5-44 |
| Stoplight Switch .....                                | 5-5  | Inspection Chart .....                | 5-49 |
| Brake Pipes .....                                     | 5-5  | Bendix Brake Systems .....            | 5-50 |
| Brake Hoses .....                                     | 5-5  | Disk Brake Shoe Lining .....          | 5-50 |
| Vacuum Booster Filters .....                          | 5-6  | Caliper Overhaul .....                | 5-51 |
| Bleeding and Flushing Brakes .....                    | 5-12 | Bendix Min. Master Cylinder .....     | 5-53 |
| Parking Brake, Pedal or Handle .....                  | 5-13 | Bendix Hydro Boost .....              | 5-54 |
| Parking Brake (Propellershaft Internal Expanding) ... | 5-16 | Hydro Boost Bleeding Procedure .....  | 5-59 |
| Combination Valve .....                               | 5-16 | Hydro Boost Brake Systems .....       | 5-60 |
| Height Sensing Proportioning Valve .....              | 5-20 | Hydro Boost Diagnosis .....           | 5-62 |
| Rotor Servicing .....                                 | 5-21 | Specifications .....                  | 5-69 |
| Brake Drums .....                                     | 5-23 | Brake System Description .....        | 5-69 |
| Conventional Drum Brakes .....                        | 5-24 | Torque Specs. ....                    | 5-70 |
| Direct Torque Drum Brake .....                        | 5-27 | Special Tools .....                   | 5-71 |
| Propeller Shaft Brake .....                           | 5-23 |                                       |      |

### GENERAL INFORMATION

The following service procedures are made for quick and easy access. Refer to the proper brake system for specific service procedures and descriptions.

### DIAGNOSIS

#### INSPECTION AND TESTING BRAKES

##### Testing Brakes

Brakes should be tested on dry, clean, reasonably smooth and level roadway. A true test of brake performance cannot be made if roadway is wet, greasy or covered with loose dirt so that all tires do not grip the road equally. Testing will also be adversely affected if roadway is crowned so as to throw weight of vehicle toward wheels on one side or if roadway is so rough that wheels tend to bounce.

Test brakes at different vehicle speeds with both light and heavy pedal pressure; however, avoid locking the wheels and sliding the tires on roadway. Locked wheels and sliding tires do not indicate brake efficiency since heavily braked but turning wheels will stop vehicle in less distance than locked wheels. More tire-to-road friction is present with a heavily braked turning tire than with a sliding tire.

##### External Conditions that Affect Brake Performance

1. **Tires**--Tires having unequal contact and grip on road will cause unequal braking. Tires must be

equally inflated and tread pattern of right and left tires must be approximately equal.

2. **Vehicle Loading**--When vehicle has unequal loading, the most heavily loaded wheels require more braking power than others. A heavily loaded vehicle requires more braking effort.
3. **Front Wheel Bearing**--A loose front wheel bearing permits the disc to tilt and have spotty contact with the linings causing erratic action.
4. **Front End Alignment**--Misalignment of the front end, particularly in regard to limits on camber and theoretical king pin inclination, will cause the brakes to pull to one side.

| CAUSE  | SYMPTOM | Excessive Brake Pedal Travel | Brake Pedal Gradually Increases | Excessive Brake Pedal Effort | Excessive Braking Action | Brakes Slow to Respond | Brakes Slow to Release | Brakes Drag | Uneven Braking Action (Side to Side) | Uneven Braking Action (Front to Rear) | Scraping Noise from Brakes | Brakes Squeak During Application | Brakes Squeak During Brakes | Brakes Chatter During Stop | Brakes Groan (Roughness) | Brake Tell-Tale Glows During Stop |
|--|---------|------------------------------|---------------------------------|------------------------------|--------------------------|------------------------|------------------------|-------------|--------------------------------------|---------------------------------------|----------------------------|----------------------------------|-----------------------------|----------------------------|--------------------------|-----------------------------------|
| Leaking Brake Line or Connection                                 |         | X                            | XX                              |                              |                          |                        |                        |             |                                      |                                       |                            |                                  | X                           |                            |                          | XX                                |
| Leaking Wheel Cylinder or Piston Seal                            |         | X                            | XX                              |                              |                          | X                      |                        |             |                                      | X                                     |                            |                                  |                             |                            |                          | X                                 |
| Leaking Master Cylinder  |         | X                            | XX                              |                              |                          |                        |                        |             |                                      |                                       |                            |                                  |                             |                            |                          | X                                 |
| Air In Brake System  |         |                              |                                 | XX                           |                          |                        |                        |             |                                      |                                       |                            |                                  | X                           |                            |                          | XX                                |
| Contaminated or Improper Brake Fluid                             |         |                              |                                 |                              |                          |                        | X                      | X           | X                                    |                                       |                            |                                  |                             |                            |                          | X                                 |
| Leaking Vacuum System  |         |                              |                                 |                              | XX                       |                        | X                      |             |                                      |                                       |                            |                                  |                             |                            |                          |                                   |
| Restricted Air Passage in Power Head                             |         |                              |                                 |                              | X                        |                        | XX                     | X           |                                      |                                       |                            |                                  |                             |                            |                          |                                   |
| Damaged Power Head   |         |                              |                                 |                              | X                        | X                      | X                      | X           | X                                    |                                       |                            |                                  |                             |                            |                          |                                   |
| Improperly Assembled Power Head Valving                          |         |                              |                                 |                              | X                        | X                      | X                      | X           | XX                                   |                                       |                            |                                  |                             |                            |                          |                                   |
| Worn Out Brake Lining - Replace                                  |         |                              |                                 |                              | X                        | X                      |                        |             |                                      | X                                     | X                          | X                                | X                           | X                          |                          | X                                 |
| Uneven Brake Lining Wear - Replace and Correct                   |         | X                            |                                 |                              |                          | X                      |                        |             |                                      | X                                     | X                          | X                                | X                           | XX                         | X                        | X                                 |
| Glazed Brake Lining  |         |                              |                                 |                              | XX                       |                        | X                      |             |                                      | X                                     | X                          |                                  | X                           | X                          |                          |                                   |
| Incorrect Lining Material - Replace                              |         |                              |                                 |                              | X                        | X                      |                        |             |                                      | X                                     | X                          |                                  |                             | X                          |                          | X                                 |
| Contaminated Brake Lining - Replace                              |         |                              |                                 |                              |                          | XX                     |                        |             |                                      | XX                                    | XX                         | X                                | X                           | X                          |                          | X                                 |
| Linings Damaged by Abusive Use - Replace                         |         |                              |                                 |                              | X                        | XX                     |                        |             |                                      | X                                     | X                          | X                                | X                           | X                          |                          | X                                 |
| Excessive Brake Lining Dust                                      |         |                              |                                 |                              | X                        | XX                     |                        |             |                                      | XX                                    | XX                         |                                  | X                           | XX                         |                          | X                                 |
| Heat Spotted or Scored Brake Drums or Rotors                     |         |                              |                                 |                              |                          | X                      |                        |             |                                      | X                                     | X                          |                                  | X                           | X                          | XX                       | X                                 |
| Out-of-Round or Vibrating Brake Drums                            |         |                              |                                 |                              |                          |                        |                        |             |                                      |                                       |                            |                                  |                             | X                          | XX                       |                                   |
| Out-of-Parallel Brake Rotors                                     |         |                              |                                 |                              |                          |                        |                        |             |                                      |                                       |                            |                                  |                             |                            | XX                       |                                   |
| Excessive Rotor Run-Out  |         |                              |                                 |                              |                          |                        |                        |             |                                      |                                       |                            |                                  |                             |                            | X                        |                                   |
| Faulty Automatic Adjusters                                       |         | X                            |                                 |                              |                          |                        |                        |             |                                      | X                                     | X                          | X                                |                             |                            |                          | X                                 |
| Incorrect Wheel Cylinder Sizes                                   |         |                              |                                 |                              |                          | X                      | X                      |             |                                      |                                       | X                          | X                                |                             |                            |                          |                                   |
| Weak or Incorrect Brake Shoe Retention Springs                   |         |                              |                                 |                              |                          | X                      |                        | X           | XX                                   | X                                     | X                          | XX                               | X                           | XX                         |                          |                                   |
| Brake Assembly Attachments - Missing or Loose                    |         | X                            |                                 |                              |                          |                        |                        |             |                                      | X                                     | X                          | X                                | X                           | X                          | X                        | X                                 |
| Insufficient Brake Shoe Guide Lubricant                          |         |                              |                                 |                              |                          |                        |                        | X           | X                                    | X                                     | X                          | XX                               | XX                          |                            |                          |                                   |
| Restricted Brake Fluid Passage or Sticking Wheel Cylinder Piston |         |                              |                                 | X                            | X                        |                        | X                      | X           | X                                    | X                                     | X                          |                                  |                             |                            |                          |                                   |
| Faulty Metering Valve  |         | X                            |                                 |                              | X                        | X                      | X                      | X           | X                                    |                                       |                            |                                  | X                           |                            |                          | X                                 |
| Brake Pedal Linkage Interference or Binding                      |         |                              |                                 |                              |                          | X                      |                        | X           | XX                                   | XX                                    |                            |                                  |                             |                            |                          |                                   |
| Improperly Adjusted Parking Brake                                |         |                              |                                 |                              |                          |                        |                        |             |                                      | X                                     |                            |                                  |                             |                            |                          |                                   |
| Drums Tapered or Threaded  |         |                              |                                 |                              |                          |                        |                        |             |                                      |                                       |                            |                                  | XX                          |                            |                          |                                   |
| Incorrect Front End Alignment                                    |         |                              |                                 |                              |                          |                        |                        |             |                                      |                                       | XX                         |                                  |                             |                            |                          |                                   |
| Incorrect Tire Pressure  |         |                              |                                 |                              |                          |                        |                        |             |                                      |                                       | X                          | X                                |                             |                            |                          |                                   |
| Incorrect Wheel Bearing Adjustment                               |         | X                            |                                 |                              |                          |                        |                        |             |                                      |                                       |                            |                                  | X                           |                            | X                        |                                   |
| Loose Front Suspension Attachments                               |         |                              |                                 |                              |                          |                        |                        |             |                                      |                                       | X                          |                                  | XX                          |                            | X                        | X                                 |
| Out-of-Balance Wheel Assemblies                                  |         |                              |                                 |                              |                          |                        |                        |             |                                      |                                       |                            |                                  |                             |                            | XX                       |                                   |
| Operator Riding Brake Pedal                                      |         | X                            | X                               | X                            |                          |                        |                        |             |                                      | X                                     |                            | X                                |                             |                            |                          | X                                 |
| Improperly Adjusted Master Cylinder Push Rod                     |         | X                            |                                 |                              |                          |                        |                        | X           | XX                                   |                                       |                            |                                  |                             |                            |                          | X                                 |
| Sticking Wheel Cylinder or Caliper Pistons                       |         |                              |                                 |                              |                          | X                      |                        | X           | X                                    | X                                     | X                          |                                  |                             |                            |                          |                                   |
| Faulty Proportioning Valve                                       |         |                              |                                 |                              |                          | X                      |                        | X           | X                                    | X                                     |                            |                                  |                             |                            |                          |                                   |

XX - Indicates more probable causes) X - Indicates causes

## GENERAL INFORMATION AND SERVICE

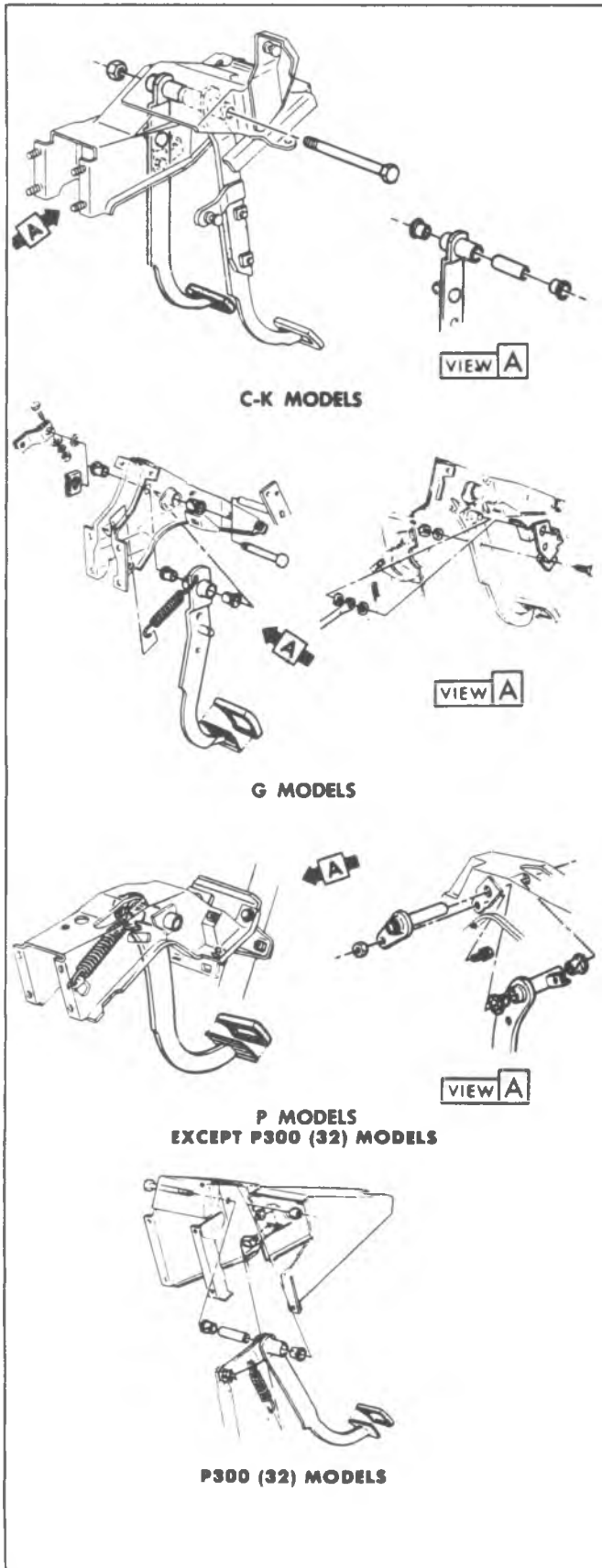

Fig. 5-1--Brake Pedal Installation

### PEDAL TRAVEL

At reasonably frequent intervals, the brakes should be inspected for pedal travel, which is the distance the pedal moves toward the floor from a fully-released' position. Inspection should be made with the brake pedal firmly depressed (approximately 90 lbs.) while the brakes are cold.

- C-K-G Manual .....4.5" (115mm)
- C-K-G Power .....3.5" (90mm)
- P (Except JF9) .....3.5" (90mm)
- P (JF9) .....6.0" (150mm)

On power brake-equipped vehicles, pump the pedal a minimum of 3 times with the engine off before making pedal travel checks. This exhausts all vacuum from the power booster.

### BRAKE PEDAL

The brake pedal mounting is an integral design with the clutch pedal (except automatic transmission), necessitating the removal of the clutch pedal before removing the brake pedal.

#### Removal (Fig. 5-1)

1. Remove the pull back spring from the body or brake pedal support bracket.
2. **Manual Transmission Vehicles**--Remove the clutch pedal as outlined in the Clutch Section.

### BRAKE PEDAL ROD

#### P30(32) Models

#### Replacement (Fig. 5-2)

1. Remove the cotter pin, nut, special washers and bolt at the brake pedal lever end of rod; discard the cotter pin.
2. Remove the boot to floorpan screws.
3. Raise the vehicle on a hoist.
4. Remove the cotter pin, nut, special washers and bolt at the lower end of the rod and remove the pedal rod assembly. Discard the cotter pin.
5. To install a new rod, adjust the rod length to 31.00" (790 mm) (center of lower attachment).
6. Lubricate the pedal rod bolts and special washers with Delco Brake Lube (or equivalent).
7. Install the rod up through the floor pan opening and install the lower pivot bolt, special washers and nut. Tighten the nut to 22-30 lb. ft. (30-40 N·m) and install a NEW cotter pin.
8. Push the boot up to the floorpan.
9. Lower the vehicle from the hoist.
10. Install the rod upper pivot bolt, special washers and nut. Tighten the nut to 22-30 lb. ft. (30-40 N·m) and install a NEW cotter pin.
11. Fasten the boot to the floorpan and compress the boot to 2.54" (65 mm) installed height; tighten the boot to 2.54" (65 mm) install height; tighten the boot screws to 13-18 lb. in. (1.5-2.0 N·m).



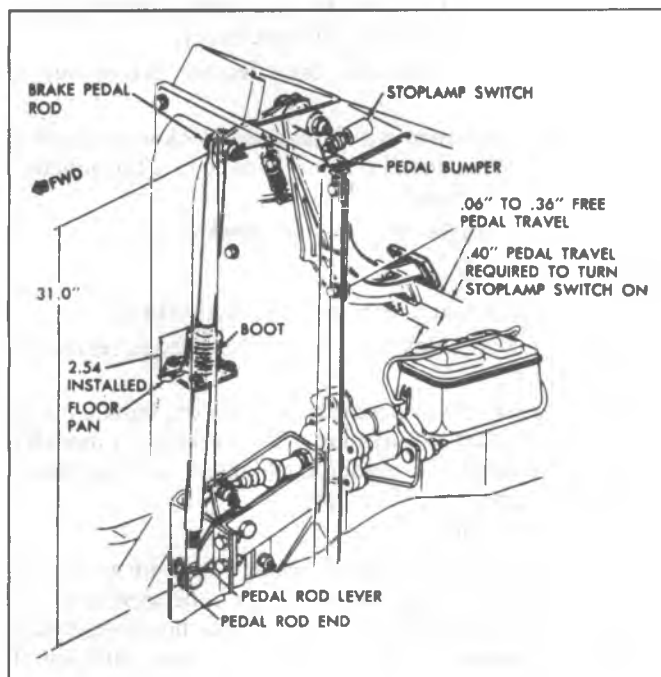

Fig. 5-2--Brake Pedal and Stoplamp Adjustment P30(32) Model

- Adjust brake pedal and stoplamp switch as outlined previously.

### P30(42) and G Models

#### Replacement

- G Models**--Remove the brake pedal striker screw and remove the striker. Remove the cotter pin and washer and disconnect the pedal rod from the brake pedal.
- P30(42) Models**--Remove the cotter pin nut and bolt to disconnect the pedal rod from the brake pedal.
- Remove the pedal rod retainer bolt (at the rod pivot) and remove the retainer.
- Remove the cotter pin and washer and remove the pedal rod.
- To install a new rod, reverse Steps 1-4 above. Lubricate pivot points with Delco Brake Lube (or equivalent).

**NOTICE:** See "Notice" on Page 1 of this section.

- Check brake pedal and stoplamp switch adjustments as outlined previously.

### STOP LIGHT SWITCH

#### Adjustment (Fig. 5-3)

The design of the switch and valve mounting provides for automatic adjustment when the brake pedal is manually returned to its mechanical stop as follows:

- With brake pedal depressed, insert switch and/or valve assembly into tubular clip until switch body and/or valve assembly seats on tube clip. Note that audible "clicks" can be heard as threaded portion of switch and valve are pushed through the clip toward the brake pedal.
- Pull brake pedal fully rearward against pedal stop, until audible "click" sounds can no longer be heard. Switch and/or valve assembly will be move in tubular clip providing proper adjustment.
- Release brake pedal, then repeat Step 2 to assure that no audible "click" sounds remain.

Electrical contact should be made when the brake pedal is depressed 1.0-1.24" (25-31 mm) (C-K models), .45-.95" (11-24 mm) (G-P models) from its fully released position.

### BRAKE PIPES

#### Replacement (Fig. 5-5 thru 5-7)

**NOTICE:** Never use copper tubing because copper is subject to fatigue cracking and corrosion which could result in brake failure.

- Procure the recommended tubing and steel fitting nuts of the correct size. (Outside diameter of tubing is used to specify size.)
- Cut tubing to length. Correct length may be determined by measuring old pipe using a cord and adding 1/8" (3mm) for each double flare.
- Double flare tubing ends using a suitable flaring tool such as J-23530. Follow instructions included in tool set. See Figures 5-4.

Make sure fittings are installed before starting second flare.

**NOTICE:** Double flaring tool must be used as single flaring tools cannot produce a flare strong enough to hold the necessary pressure.

- Bend pipe assembly to match old pipe using a tubing bender. Clearance of .75" (19 mm) must be maintained to all moving or vibrating parts.

### BRAKE HOSES

#### Inspection

The flexible hydraulic brake hose which transmits hydraulic pressure from the steel brake pipe on the frame to the rear axle and to the calipers should be inspected at the intervals shown in the Maintenance and Lubrication Section. The brake hose assembly should be checked for road hazard damage, for cracks and chafing of the outer cover, and for leaks and blisters. A light and mirror may be needed for an adequate inspection. If any of the above conditions are observed on the brake hose, it will be necessary to replace it.

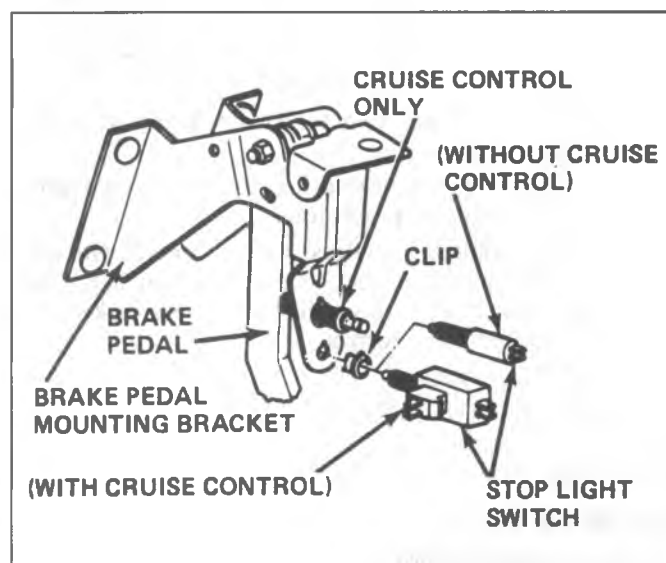

Fig. 5-3--Stoplight Switch

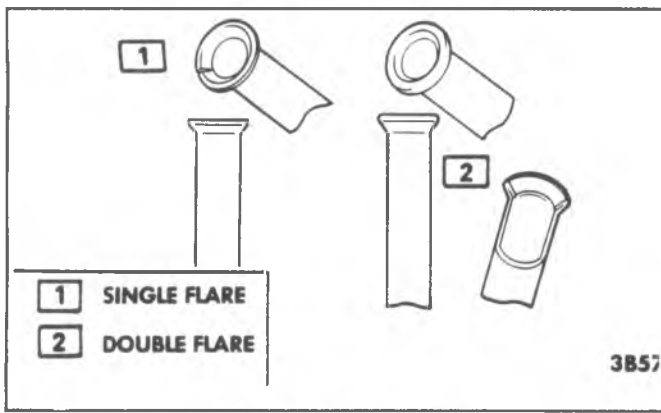

Fig. 5-4-Double Lap Flare

### Front Hose

#### Remove (Figs. 5-5 thru 5-7)

1. Raise vehicle on hoist.
2. Clean dirt and foreign material from both hose end fittings.
3. Disconnect brake pipe from hose fitting using a back-up wrench on fitting. Be careful not to bend frame bracket or brake pipe. It may be necessary to soak the connections with penetrating oil.
4. Remove "U" clip or nut from female fitting at bracket or frame and remove hose from bracket.
5. Remove bolt from caliper end of hose. Remove hose from caliper, and discard the two copper gaskets on eighter side of fitting block.

#### Installation

1. Use new copper gaskets on both sides of fitting block, wet bolt threads with brake fluid, then with fitting orientation flange engaged with the caliper orientation ledge on JB8 and JF9 (hose located in caliper gate on all except JB8 and JF9), fasten hose to caliper; torque to specifications.
2. With weight of vehicle on suspension, pass female fitting through frame or frame bracket. Fitting fits the frame or frame bracket in only one position. With least amount of twist in hose, install fitting in this position. There should be no kinks in hose.
3. Install "U" or nut clip to female fitting at frame bracket or frame.
4. Attach brake pipe to hose fitting using a backup wrench on fitting; torque to specifications.
5. Inspect to see that hose doesn't make contact with any part of suspension. Check in extreme right hand and extreme left hand turn conditions. If hose makes any contact, remove and correct.
6. Bleed brake system.
7. Lower vehicle from hoist.

### Rear Hose

#### Removal (Fig. 5-8)

1. Raise vehicle on hoist.
2. Remove all three brake pipes from hose, two at junction block and, with the use of a back-up wrench, one on the

female fitting at bracket. Be careful not to bend bracket or pipes; use penetrating oil if necessary.

3. Remove "U" clip and take female fitting out of bracket.
4. Observe position at which junction block is mounted to the axle. When installing new hose be sure this junction block is in the same position.
5. Remove bolt attaching junction block to axle.

#### Installation

1. Thread both rear axle pipes into junction block.
2. Bolt junction block to axle and then torque rear pipes into block.
3. Pass female end of hose through bracket; female fitting will fit bracket in only one position (except G models), two positions (G models). Without twisting hose, position female end in bracket.
4. Install "U" clip.
5. Attach pipe to female fitting using a back-up wrench on fitting; torque to specification, again be careful not to bend bracket or pipe. Check to see that hose installation did not loosen frame bracket. Retorque bracket if necessary.
6. Bleed system.
7. Lower vehicle from hoist.

### POWER BRAKE VACUUM HOSE FILTER

#### Removal

1. Use a pair of pliers to move the hose clamp approximately 2" (50mm).
2. Twist the filter in the hose to break the seal and remove the filter.

#### Installation

1. Install the filter. Be sure the vacuum check valve on the power brake unit is positioned from vertical as shown in Figures 5-9 and 5-10.
2. Position hose clamp to retain filter.

### POWER BRAKE UNIT

#### Vacuum Booster

#### Replacement (Fig. 5-11)

**NOTICE:** See "Notice" on Page 1 of this section when installing fasteners referred to in Steps 6, 7 and 9 below.

1. Remove two nuts holding master cylinder to power cylinder and position it away from power cylinder. Do not disconnect hydraulic brake lines; be careful not to bend or kink pipes.
2. Disconnect the vacuum hose from the vacuum check valve on the front housing of the power head. Plug vacuum hose to prevent dust and dirt from entering hose.
3. Disconnect the power brake push rod from the brake pedal.
4. Remove the four nuts from the mounting studs which hold the power brake to the cowl.
5. Carry the power brake to a clean work area and clean the exterior of the power brake prior to disassembly.
6. Mount power brake assembly to cowl and torque nuts

Fig. 5-5--Front Brake Pipes and Hoses-C-K Models

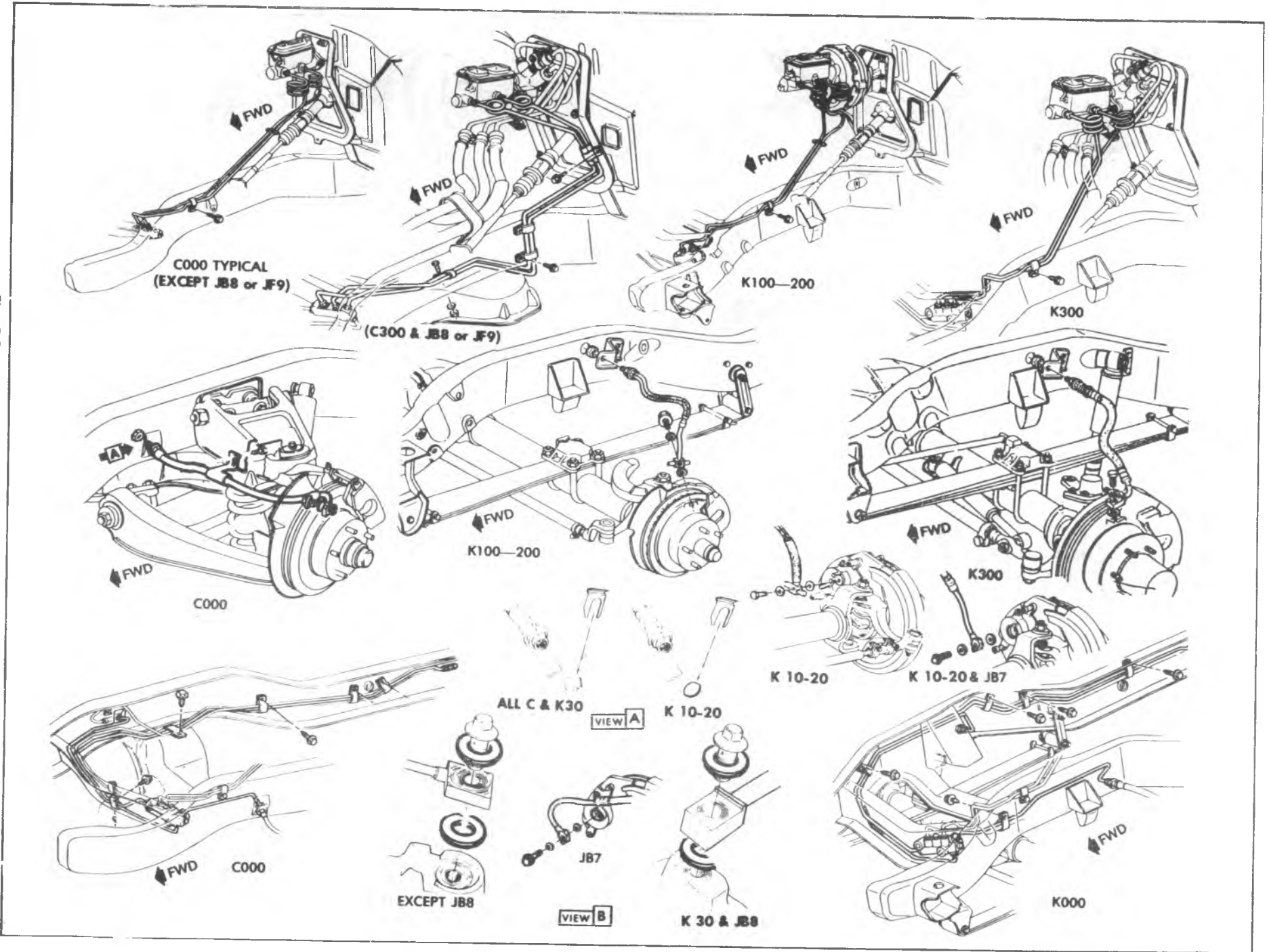

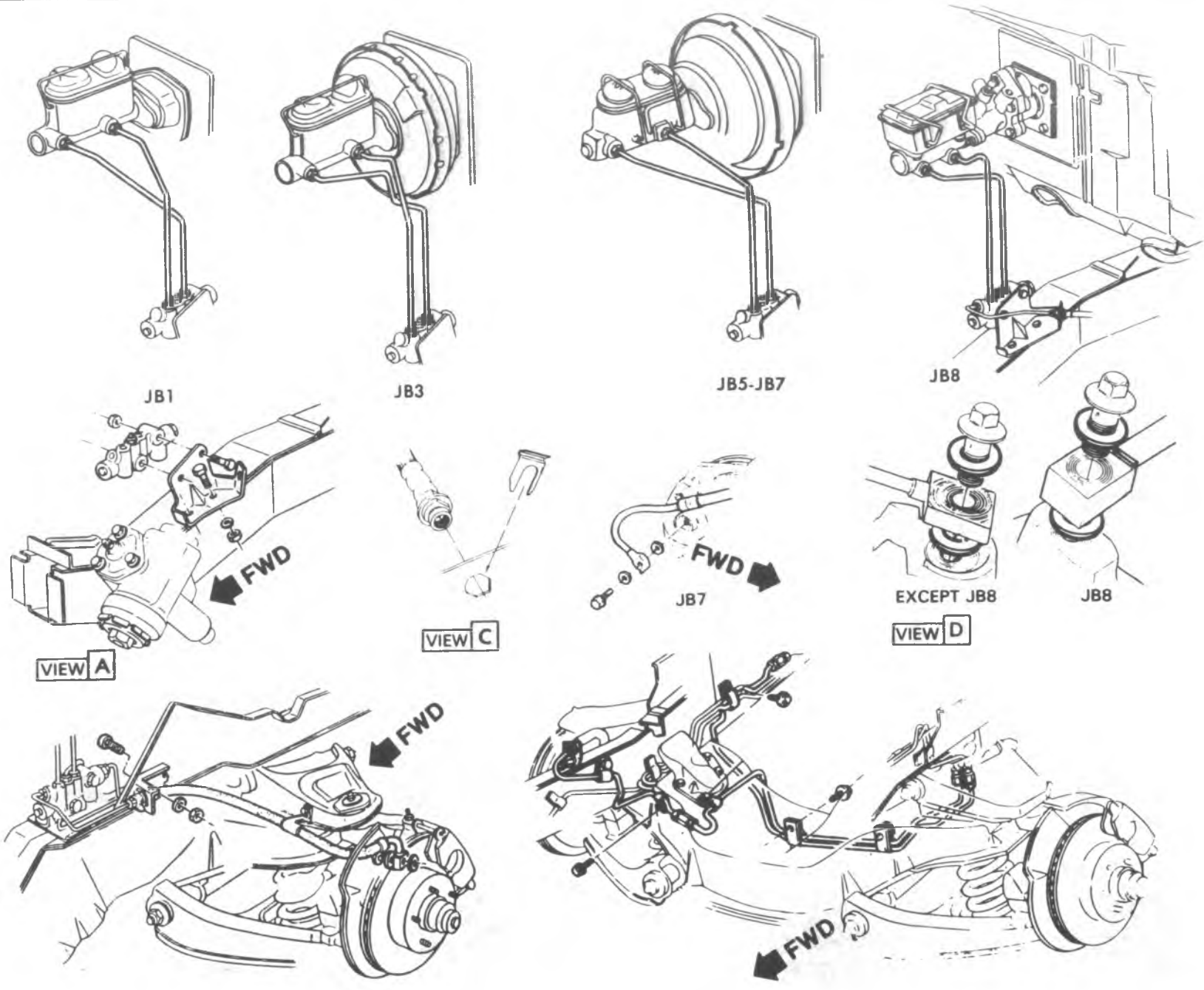
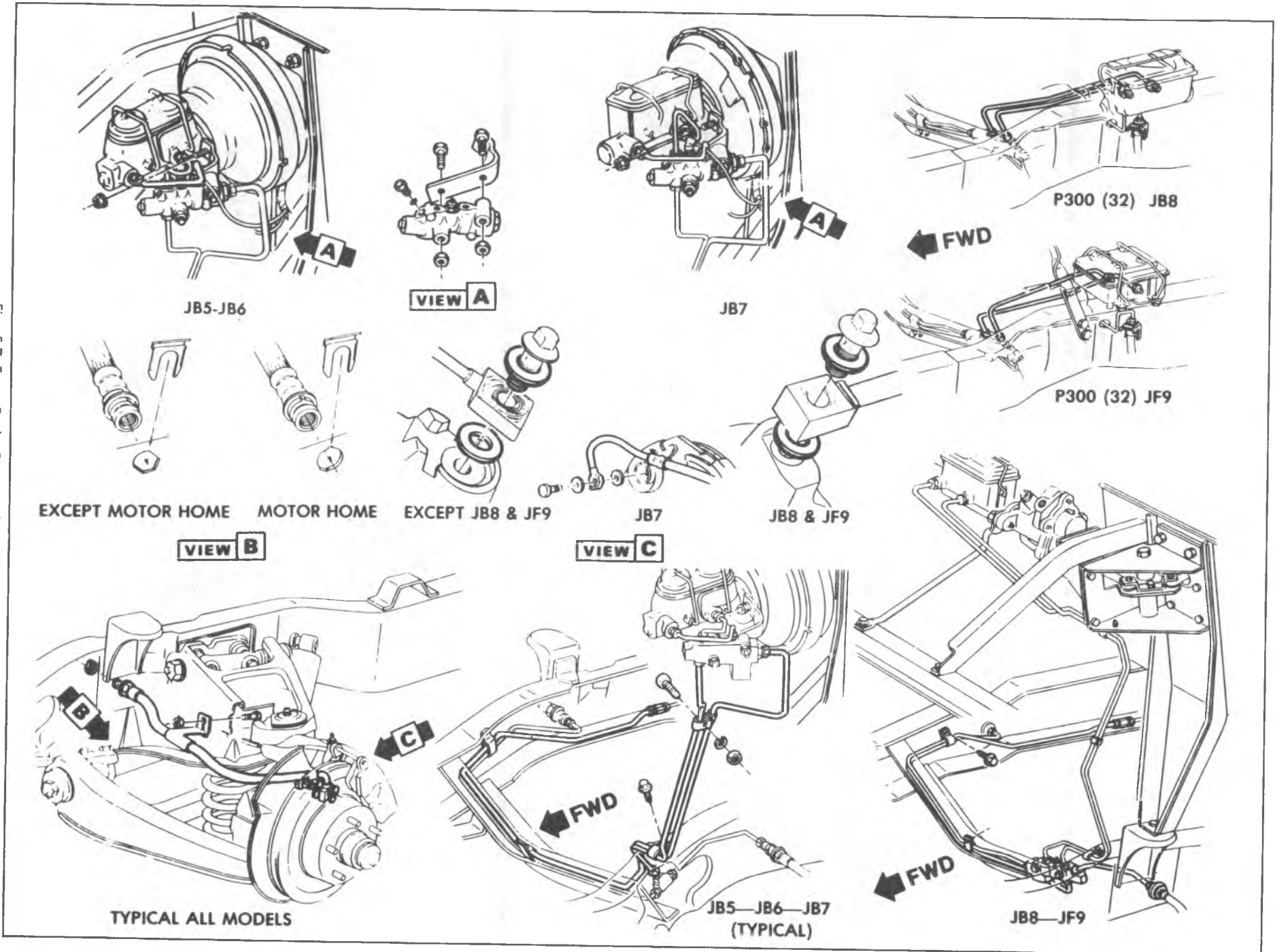

Fig. 5-6--Front Brake Pipes and Hoses-G Models

Fig. 5-7--Front Brake Pipes and Hoses-P Models



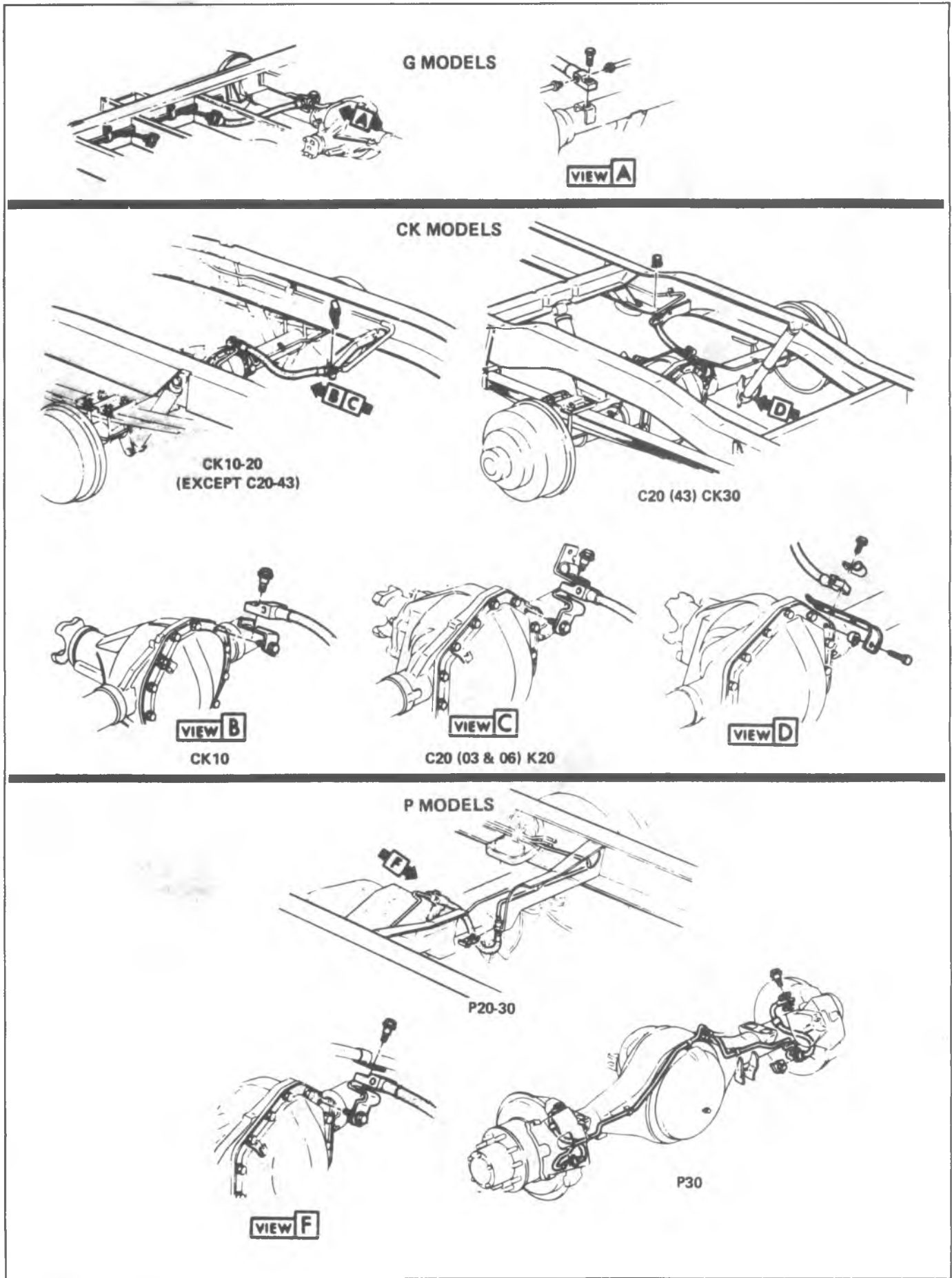
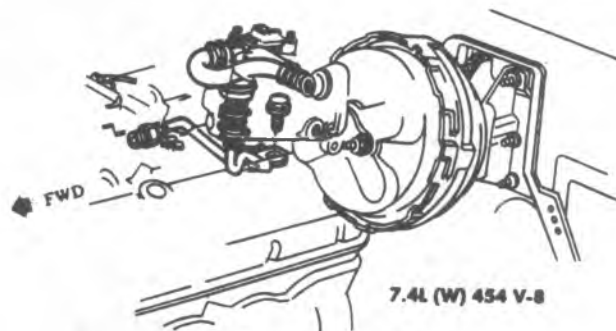
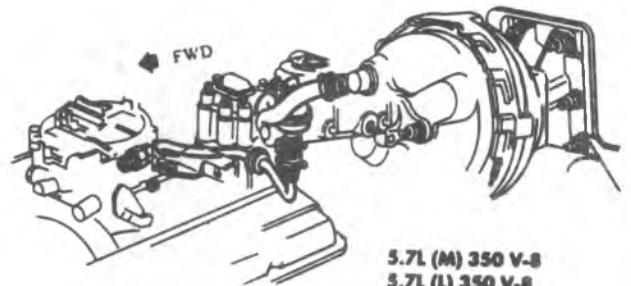
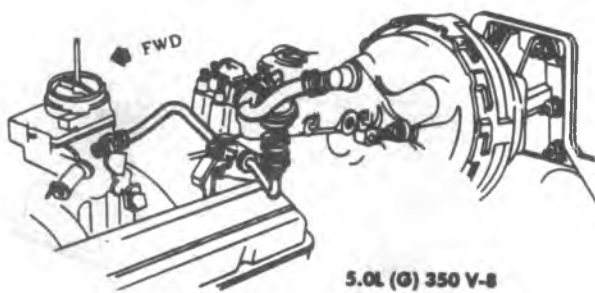
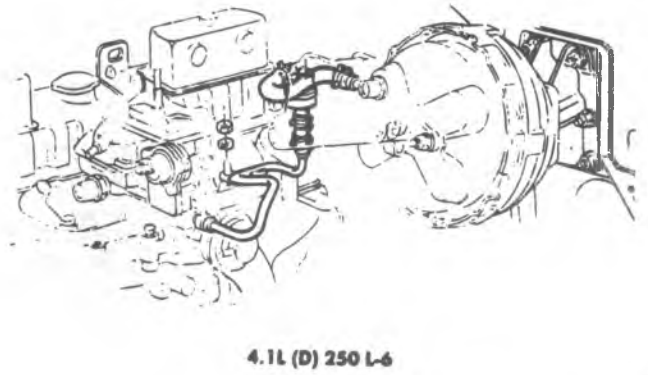
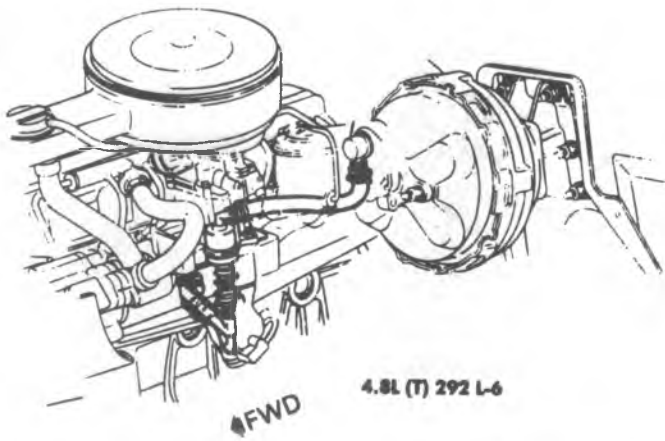

Fig. 5-8 — Rear Brake Hoses.



**C-K MODELS**



**P MODELS**

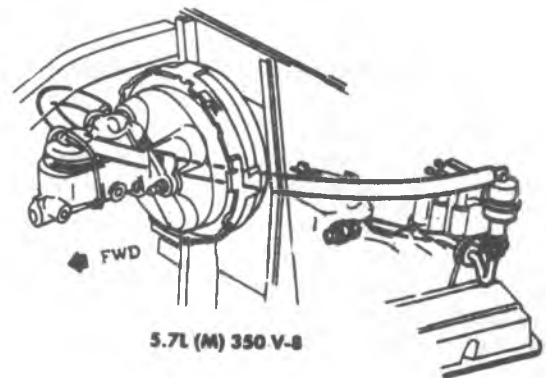
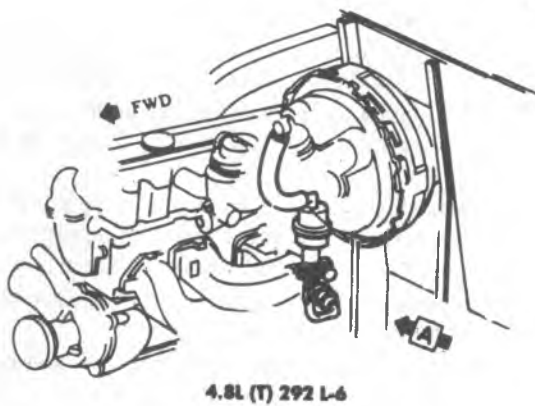

Fig. 5-9--Power Brake Vacuum Hose Filter Installation-C-K-P Trucks

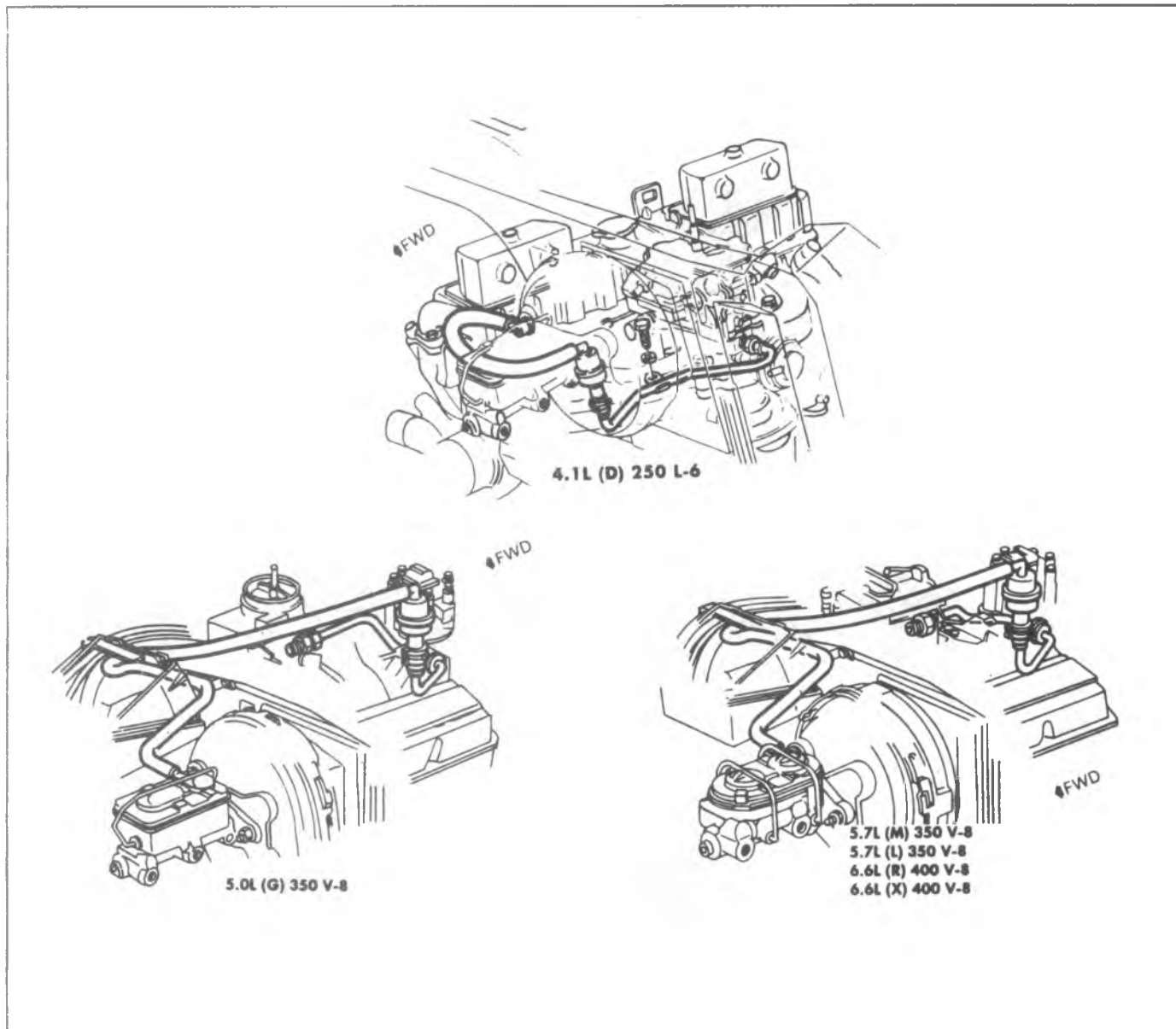

Fig. 5-10--Power Brake Vacuum Hose Filter Installation-G Models

to specified torque.

7. Connect power brake push rod to brake pedal.
8. Connect vacuum hose to vacuum check valve.
9. Connect master cylinder to power cylinder and torque nuts to specifications.

## BLEEDING AND FLUSHING BRAKE SYSTEM

### Bleeding Brake Hydraulic System

A bleeding operation is necessary to remove air whenever it is introduced into the hydraulic brake system.

It may be necessary to bleed the hydraulic system at all four foundation brakes if air has been introduced through low fluid level or by disconnecting brake pipes at master cylinder. If brake pipe is disconnected at any wheel cylinder, or caliper, then that wheel cylinder or caliper only need be bled. If pipes are disconnected at any fitting located between master cylinder and foundation brakes, then all foundation brakes served by the disconnected pipe must be bled.

**Time required to bleed the hydraulic system when the master cylinder is removed can be reduced if the master**

**cylinder is filled with fluid and as much air as possible is expelled before the cylinder is installed on the vehicle..**

### Manual Bleeding

With power brakes, remove the vacuum reserve by applying the brakes several times with the engine off.

1. Fill the master cylinder reservoirs with brake fluid and keep at least one-half full of fluid during the bleeding operation.
2. If the master cylinder is known or suspected to have air in the bore, then it must be bled before any wheel cylinder or caliper in the following manner:
  - a. Disconnect the forward (blind end) brake pipe connection at the master cylinder.
  - b. Allow brake fluid to fill the master cylinder bore until it begins to flow from the forward pipe connector port.
  - c. Connect the forward brake pipe to the master cylinder and tighten.
  - d. Depress the brake pedal slowly one time and



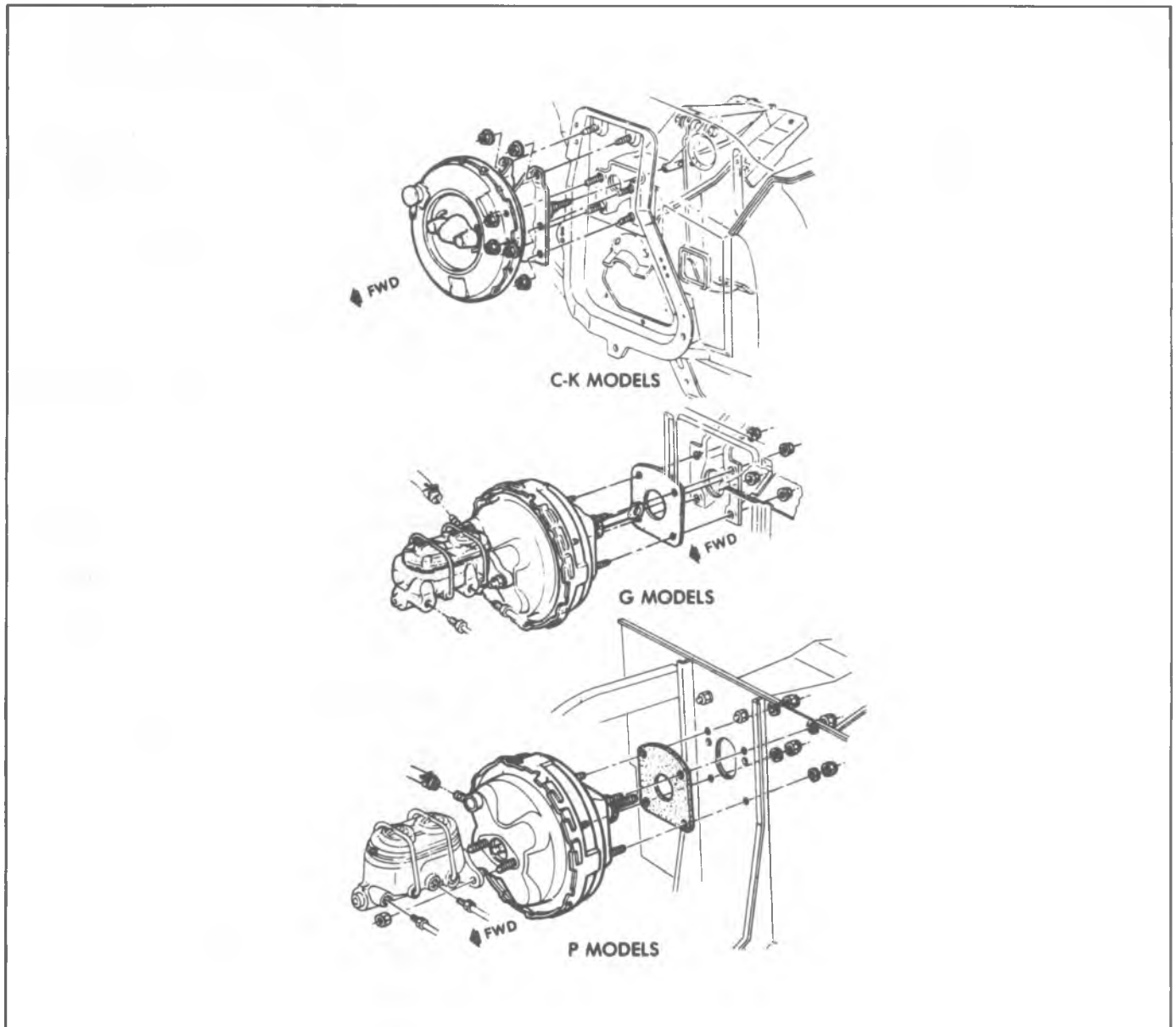

Fig. 5-11--Vacuum Booster Installation

hold. Loosen the forward brake pipe connection at the master cylinder to purge air from the bore. Tighten the connection and then release the brake pedal slowly. Wait 15 seconds. Repeat the sequence, including the 15 second wait, until all air is removed from the bore. Care must be taken to prevent brake fluid from contacting any painted surface.

- e. After all air has been removed at the forward connection, bleed the master cylinder at the rear (cowl) connection in the same manner as the front in Step "d" above.
  - f. If it is known that the calipers and wheel cylinders do not contain any air, then it will not be necessary to bleed them.
3. Individual wheel cylinder or calipers are bled only after all air is removed from master cylinder.
    - a. Place a proper size box end wrench or Tool J-21472 over the bleeder valve. Attach transparent tube over valve and allow tube to be hand submerged in brake

fluid in a transparent container. Depress the brake pedal slowly one time and hold. Loosen the bleeder valve to purge the air from the cylinder. Tighten bleeder screw and slowly release pedal. Wait 15 seconds. Repeat the sequence, including the 15 second wait until all air is removed. It may be necessary to repeat the sequence 10 or more times to remove all the air. **JB1 thru JB6 gas engine vehicle--Rapid pumping of the brake pedal pushes the master cylinder secondary piston down the bore in a manner that makes it difficult to bleed the rear side of the system.**

4. It is necessary to bleed all of the wheel cylinders and calipers, the following sequence should be followed: 1)Right rear wheel cylinder; 2)Left rear wheel cylinder; 3)Right front caliper; 4)Left front caliper.
5. Check the brake pedal for "sponginess" and the brake warning light for indication of unbalanced pressure. Repeat entire bleeding procedure to correct either of these two conditions.

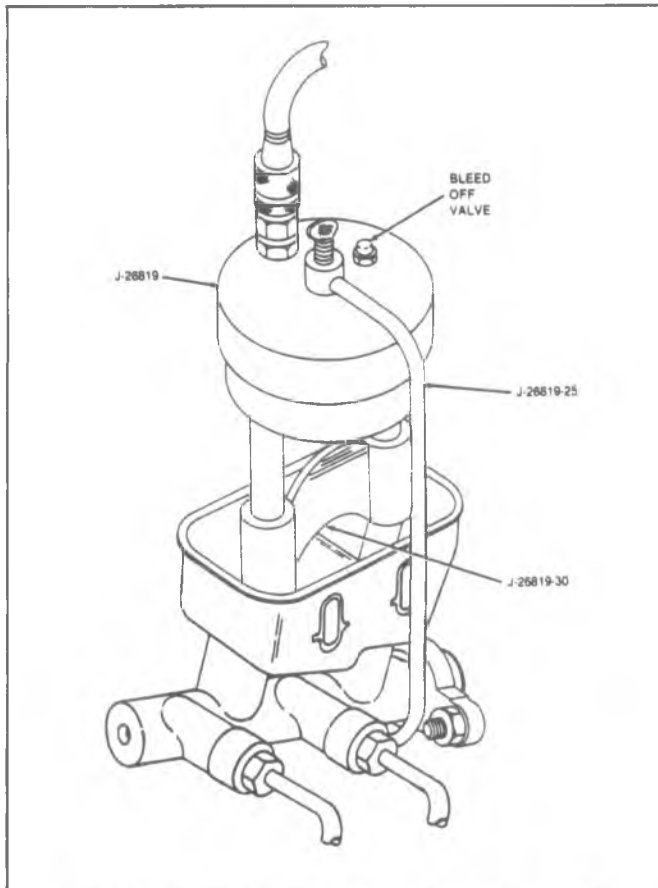

Fig. 5-12--Pressure Bleeding (CK Models JB1 thru JB6)

### Pressure Bleeding

Pressure bleeding equipment must be of the diaphragm type. That is, it must have a rubber diaphragm between the air supply and the brake fluid to prevent air, moisture, oil and other contaminants from entering the hydraulic system.

1. Install the correct pressure bleeding adapter to the master cylinder. Brake Systems JB1 through JB6 gas engine vehicles require adapter J-26819, extension J-26819-30 and clamp J-26819-25. All other systems use J-23518. Refer to Fig. 5-12, special tool illustration and brake system description chart.

**NOTICE:** It is very important that the correct master cylinder bleeder adapter be used to avoid possible damage to the master cylinder bleeder adapter be used to avoid possible damage to the master cylinder reservoir (Fig. 5-12).

2. Make sure the pressure tank is at least 1/3 full of Supreme #11 brake fluid or its equivalent.

The bleeder must be re-bled each time fluid is added.

3. Charge the bleeder ball to between 140-170 kPa (20 and 25 psi).
4. When ready to begin bleeding, connect hose to master cylinder bleeder adapter and open the tank valve.
5. Disc brakes may require a manual override of the front brake metering or combination valve to permit flow to the front wheels. Therefore, it may be necessary to hold the valve stem open manually during pressure bleeding.

To hold the metering valve open to bleed the front brakes, the valve stem must be either pushed in or pulled out. Install metering valve actuator J-23709.

6. Bleed the brakes in the following sequence: right rear, left rear, left front and right front.
7. With the proper size wrench over the bleeder valve attach bleeder tube. The discharge end must hang submerged in a clean container partially filled with brake fluid.
8. Open the bleeder valve at least 3/4 turn and allow flow to continue until no air is seen in the fluid.
9. Close the bleed valve. Be sure it seals.
10. Repeat Steps 7-9 for the remaining bleeder valves (see Step 6 for sequence).
11. Check the pedal feel for "sponginess" and repeat the entire procedure if necessary.
12. Dispose of all removed brake fluid.
13. Remove Tool J-23709 from the combination valve and tighten the mounting bolt.
14. Disconnect bleeder equipment from the brake bleeder adapter.
15. Remove bleeder adapter. Wipe all areas dry if fluid was spilled during adapter removal.
16. Fill master cylinder reservoir(s) to proper level and install master cylinder diaphragm and cover.

### Flushing Brake Hydraulic System

It is recommended that the entire hydraulic system be thoroughly flushed with clean brake fluid whenever new parts are installed in the hydraulic system.

Flushing is also recommended if there is any doubt as to the grade of fluid in the system. If fluid has been used which contains the slightest trace of mineral oil, all rubber parts that have been subjected to the contaminated fluid should be replaced.

### PARKING BRAKE PEDAL OR HANDLE

#### Removal (Fig. 5-13)

1. Place parking brake pedal or handle in the released position.
2. Remove nuts from the engine compartment on C, K and G models or bolts from mounting bracket on P models. Take notice of the spacers on P models for reinstallation.
3. Disconnect the release handle rod at the parking brake assembly end (C-K models).
4. Remove the bolts from the underside of the dash and lower the brake assembly (C-K-G Models).
5. **C-K-G Models-** Disconnect the cable ball from the parking brake clevis and remove the assembly.  
**P Models-** Remove the clevis pin and disconnect the cable from the brake assembly; remove the assembly.

#### Installation

Reverse the removal procedure. Torque all bolts and nuts. After installing the clevis-pin, use a new cotter pin to secure the clevis pin. Adjust the cable if necessary as outlined below.

**NOTICE:** SEE "Notice" on Page 1 of this section.

**NOTICE:** Adjustment of parking brake cable is necessary whenever holding ability is not adequate or

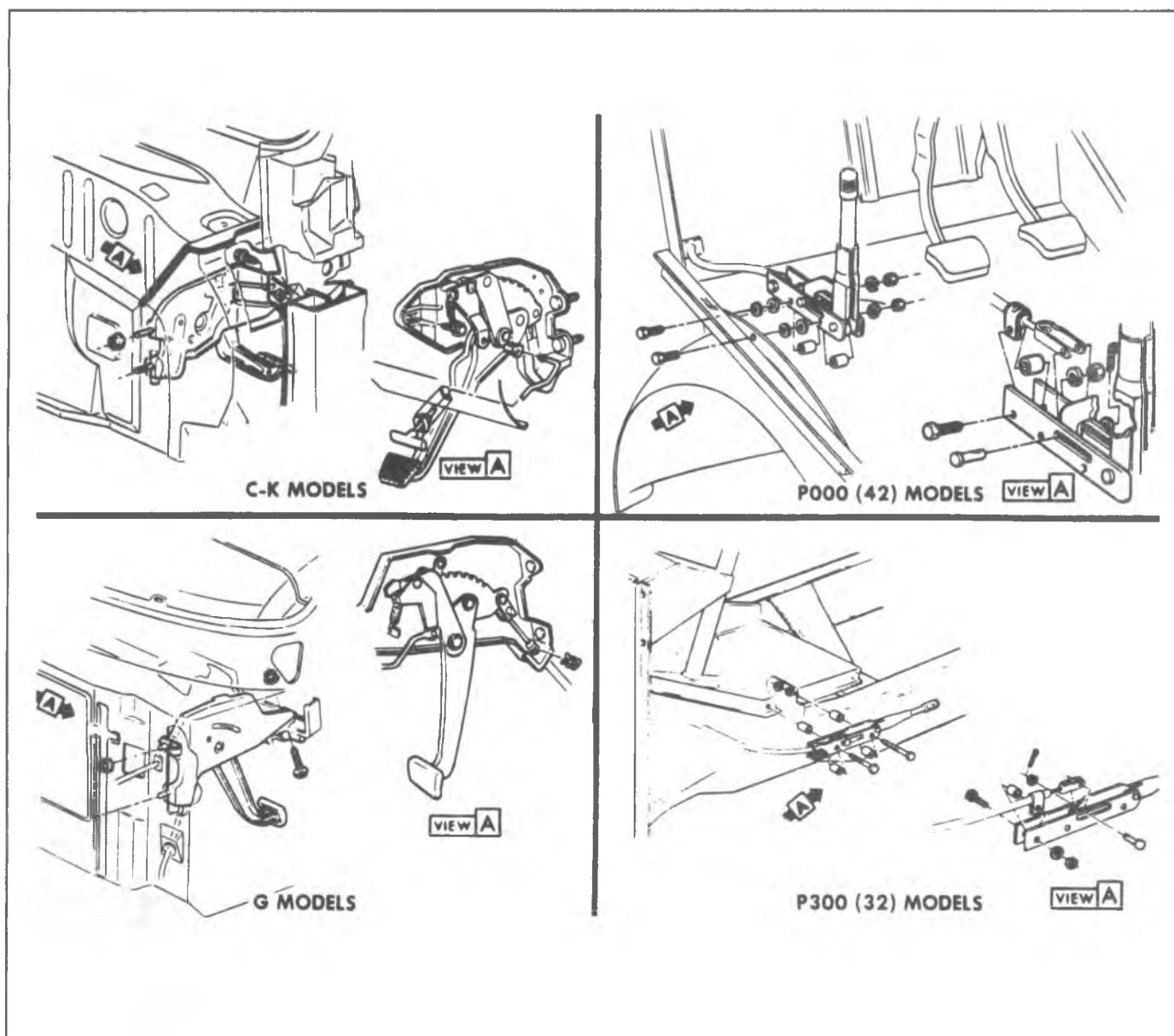

Fig. 5-13--Parking Brake Assembly-Typical

whenever the center brake cables have been disconnected.

**NOTICE:** The service brake must be properly adjusted as a base for parking brake adjustment; conversely the parking brake must be properly adjusted for the service brake to function as intended.

#### Inspection

If complete release of the parking brake is not obtained, unless it is forcibly returned to its released position, or if application effort is high, check parking brake assembly for free operation. If operation is sticky or a bind is experienced, correct as follows:

1. Clean and lubricate brake cables and equalizer with Delco Brake Lube (or equivalent).
2. Inspect brake assembly for straightness and alignment (replace if necessary).
3. Clean and lubricate parking brake assembly with Delco Brake Lube (or equivalent).
4. Checking routing of cables for kinks or binding.

#### Adjustment--Foot Pedal Type

Before adjusting parking brake, check service brake condition and adjustment.

1. Raise vehicle on hoist.
2. Loosen the equalizer adjusting nut.
3. Apply parking brake 4 notches from fully released position.
4. Tighten the equalizer nut until a moderate drag is felt when the rear wheels are rotated forward.
5. Fully release parking brake and rotate the rear wheels. No drag should be present.
6. Remove vehicle from hoist.

#### Adjustment--Orscheln Lever Type

1. Turn adjusting knob on parking brake lever counterclockwise to stop.
2. Apply parking brake.
3. Raise vehicle on a hoist.
4. Loosen nut at intermediate cable equalizer and then adjust nut to give light drag at rear wheels.

**NOTICE:** See "Notice" on Page 1 of this section.

5. Readjust parking brake lever knob to give a definite snap-over-center feel.

## PARKING BRAKE (PROPELLER SHAFT) P-30 (Fig. 5-14)

### INTERNAL EXPANDING

#### Adjustment-Drum On

1. Jack up at least one rear wheel. Block wheels and release hand brake.
2. Remove cotter pin and clevis pin connecting pull rod and relay lever. This will assure freedom for full shoe release.

**NOTICE:** It may be necessary to knock out lanced area in brake drum with a punch and hammer to gain entry into adjusting screw through brake drum. Be sure all metal has been removed from parking brake compartment.

3. Rotate brake drum to bring one of access holes into line with adjusting screw at bottom of shoes (manual transmission), top of shoes (automatic transmission).
4. Expand shoes by rotating adjusting screws with screwdriver inserted through hole in drum. Move outer end of screwdriver away from drive shaft. Continue adjustment until shoes are tight against drum and drum cannot be rotated by hand. Back off adjustment ten notches and check drum for free rotation.
5. Place parking brake lever in fully released position. Take up slack in brake linkage by pulling back on cable just enough to overcome spring tension. Adjust clevis of pull rod or front cable to line up with hole in relay levers.
  - a. Insert clevis pin and cotter pin, then tighten clevis locknut.
  - b. Install a new metal hole cover in drum to prevent contamination of brake.
  - c. Lower rear wheels. Remove jack and wheel blocks.

**NOTICE:** See "Notice" on Page 1 of this section.

#### Adjustment--Drum Off

1. With parking brake drum off, use special Tool J-21177 or J-22364, Drum to Brake Shoe Clearance Gage, to check diameter of drum clearance surface.
2. Turn the tool to the opposite side and fit over brake shoes by turning the star wheel until the gage just slides over the linings.
3. Rotate the gage around the brake shoe lining surface to insure proper clearance.
4. Install propeller shaft flange at mainshaft as outlined in Transmission Section.
5. Lower rear wheels. Remove jack and wheel blocks.

## PARKING BRAKE CABLES (Figs. 5-15 and 5-16)

### Front Cable Replacement

1. Raise vehicle on hoist.
2. Remove adjusting nut from equalizer.
3. Remove retainer clip from rear portion of front cable at frame and from lever arm.

4. Disconnect front brake cable from parking brake pedal or lever assemblies. Remove front brake cable. On some models, it may assist installation of new cable if a heavy cord is tied to other end of cable in order to guide new cable through proper routing.

5. Install cable by reversing removal procedure.
6. Adjust parking brake.

### Center Cable Replacement

1. Raise vehicle on hoist.
2. Remove adjusting nut from equalizer.
3. Unhook connector at each end and disengage hooks and guides.
4. Install new cable by reversing removal procedure.
5. Adjust parking brake.
6. Apply parking brake 3 times with heavy pressure and repeat adjustment.

### Rear Parking Brake Cable Replacement

1. Raise vehicle on hoist.
2. Remove rear wheel and brake drum.
3. Loosen adjusting nut at equalizer.
4. Disengage rear cable at connector.
5. Bend retainer fingers.
6. Disengage cable at brake shoe operating lever.
7. Install new cable by reversing removal procedure.
8. Adjust parking brake.

## COMBINATION VALE

### Electrical Circuit Test

1. Disconnect wire from switch terminal and use a jumper to connect wire to a good ground.
2. Turn ignition key on "ON" - warning lamp should light. If lamp does not light, bulb is burned out or electrical circuit is defective. Replace bulb or repair electrical circuit as necessary.
3. When warning lamp lights, turn ignition switch off. Disconnect jumper and reconnect wire to switch terminal.

### Brake Warning Light Switch Test

1. Raise vehicle on hoist. Attach a bleeder hose to a rear brake bleed screw and immerse the other end of the hose in a container partially filled with clean brake fluid. Be sure master cylinder reservoir is full.
2. Turn ignition switch to "On"; open bleeder screw while a helper applies moderate pressure to the brake pedal; warning lamp should light. Close bleeder screw before helper releases brake pedal. Reapply brake pedal with moderate-to-heavy pressure; light should go out.
3. Attach the bleeder hose to a front brake bleeder screw and repeat above test. Warning lamp action should be the same as in Step No. 2. Turn ignition switch off.
4. If warning lamp does not light during Steps 2 and 3 but does light when a jumper is connected to ground, the warning light switch portion of the combination valve is defective. Do not attempt to disassemble the combination valve. If any portion of the combination valve is defective, it must be replaced.

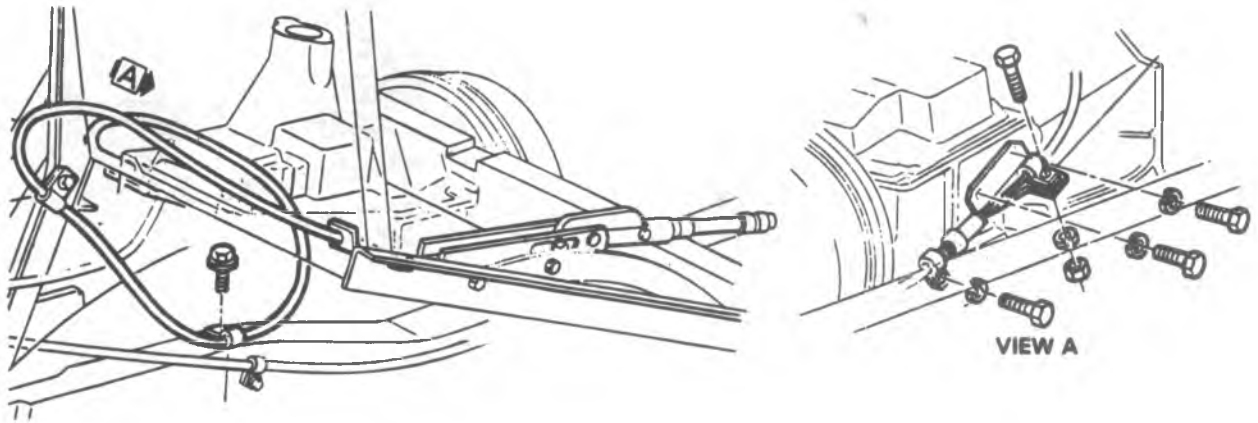

P300(42) & M20 & JF9

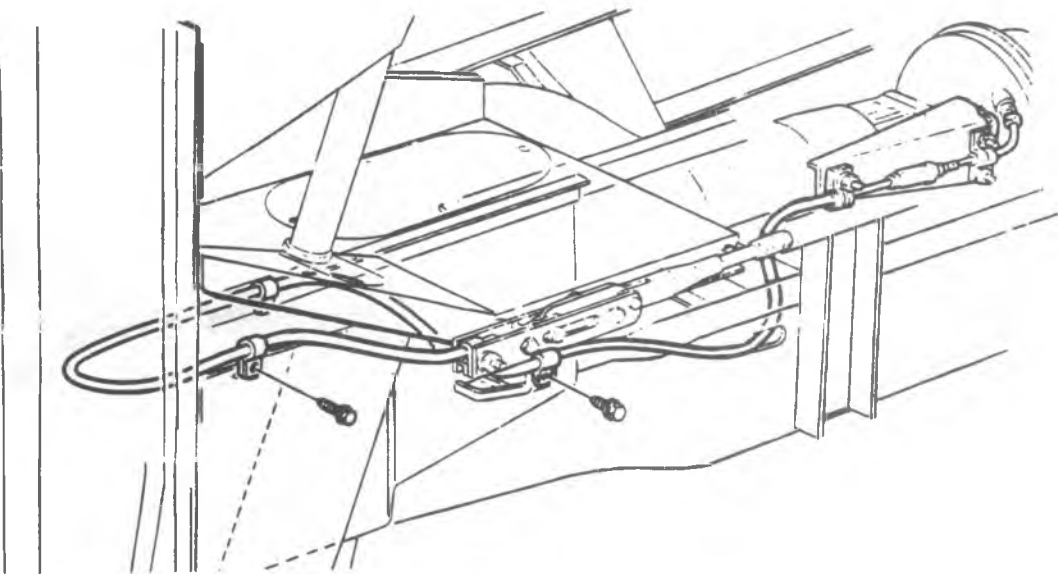

P314 (32) & JF9; P318 (32)

Fig. 5-14 — Parking Brake System P-30 Series

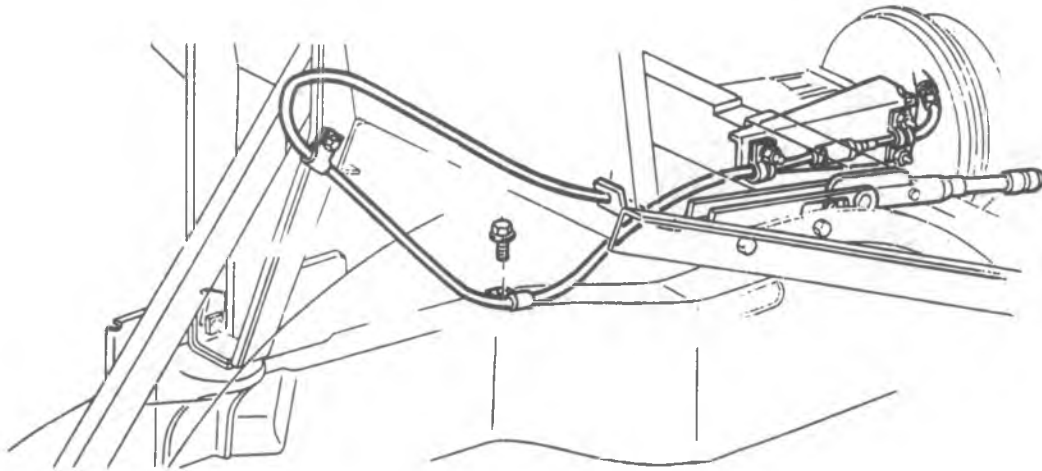

P300 (42) & M40 & JF9

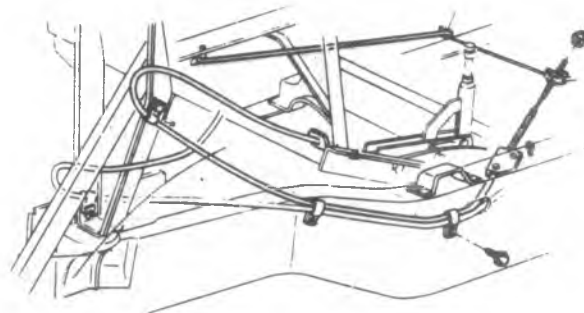
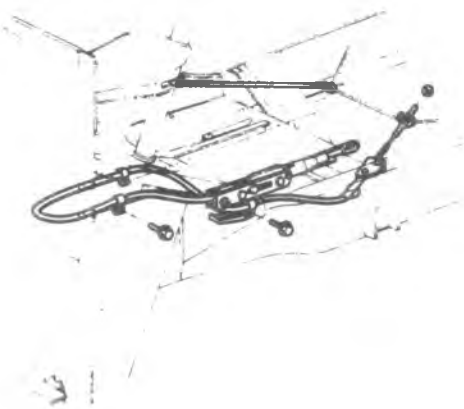

P MODELS

Fig. 5-15 — Parking Brake System P-30 Series

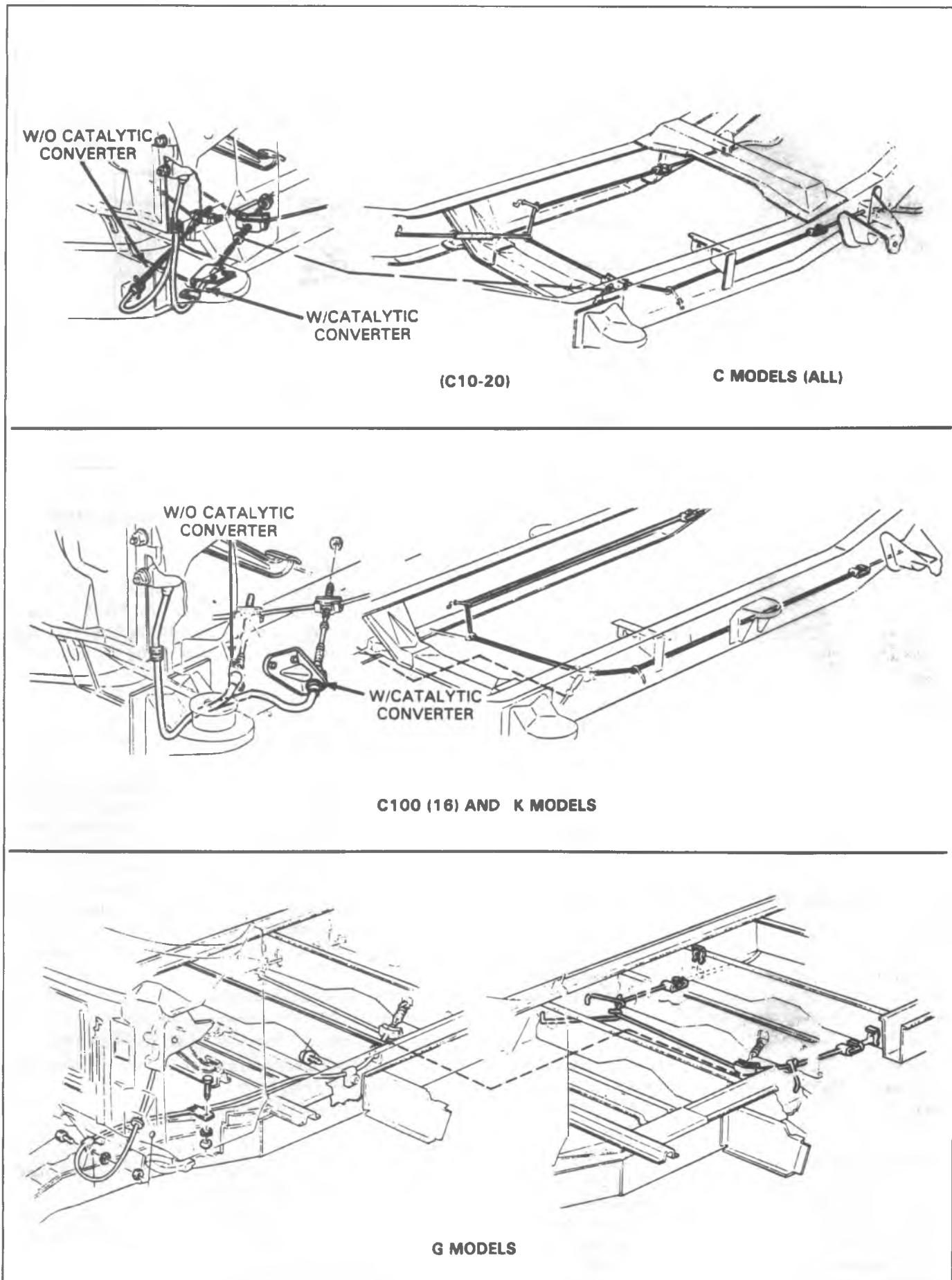

Fig. 5-16 — Parking Brake System, Typical

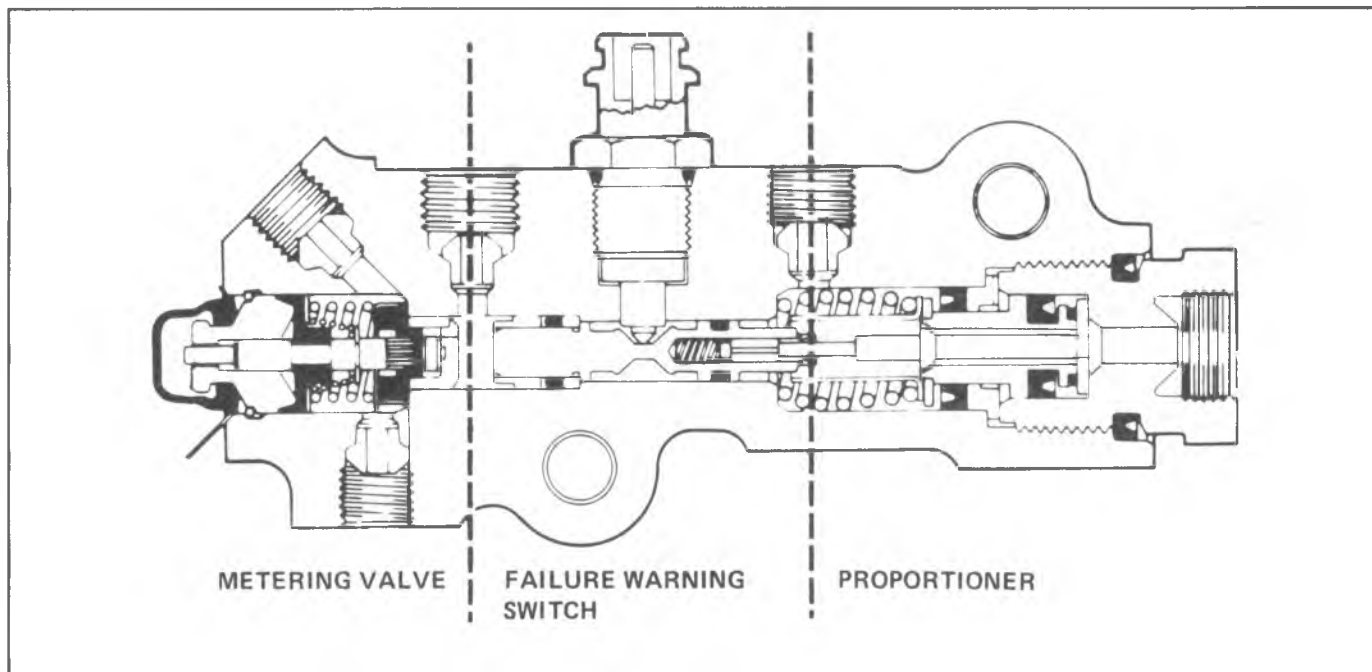

Fig. 5-17--Combination Valve

with a new combination valve.

5. Lower vehicle to floor. Check and refill master cylinder to proper level.

#### Replacement

The combination valve is not repairable and must be serviced as a complete assembly.

1. Disconnect hydraulic lines at combination valve. Plug lines to prevent loss of fluid and entrance of dirt. Disconnect warning switch wiring harness from valve switch terminal.
2. Remove combination valve.
3. Install combination valve by reversing removal steps.
4. Bleed entire brake system. Do not move vehicle until a firm brake pedal is obtained.

#### HEIGHT SENSING BRAKE PROPORTIONING VALVE

The height sensing brake proportioning valve, used on 30 series models, provides optimum brake balance and efficiency. Vehicle braking force is distributed to the front and rear wheels as defined by light or heavy payload conditions.

Mounted on the frame, the valve responds to changes in vehicle trim height as related to rear axle load. Mechanical linkage connects the valve to a bracket that is attached to the rear axle.

**CAUTION:** Adding any suspension accessories or other equipment (such as load leveling kits, air shocks, suspension lift kits, additional spring leaves, etc.), or making modification that will change the distance between the axle and the frame without changing the load, will provide a false reading to the brake proportioning valve. This could result in unsatisfactory brake performance which in turn

could result in an accident and possibly personal injury.

#### Adjustment Procedure

If diagnosis indicates front wheel lock-up is experienced when vehicle is operated at near GVWR with a lower than desired brake application rate, the height sensing proportioning valve may be adjusted using the following procedure:

1. Raise vehicle, axle must be allowed to hang free (no load condition), wheels on.
  2. Remove nut from valve shaft and remove lever (Fig. 5-18).
  3. Rotate valve shaft to permit installation of correct adjustment gage. Center hole of adjustment gage must seat on "D" shape of valve shaft and gage tang must seat in valve mounting hole as shown in Figure 5-19. Adjustment gages are available from service parts.
  4. Install lever on valve shaft by pushing plastic bushing and clip assembly over serrations on valve shaft using a "C" clamp or channel lock pliers. When properly installed, serrations on valve shaft fully engage plastic bushing.
- NOTICE:** Do not drive lever assembly on valve shaft by using nut, or proper valve setting may be disturbed.
5. Install nut and tighten to 8-11 N·m (70-98) in. lbs.).
  6. Sever tang on adjustment gage to allow valve assembly to rotate freely (Fig. 5-19).
  7. Lower vehicle and test brakes.

#### Removal

1. Raise vehicle, axle must be allowed to hang free (load condition) with wheels removed.
2. Clean exterior of valve to prevent dirt from contaminating hydraulic system when brake pipes are disconnected.
3. Disconnect brake lines from valve.
4. Remove nut from shaft and remove lever.



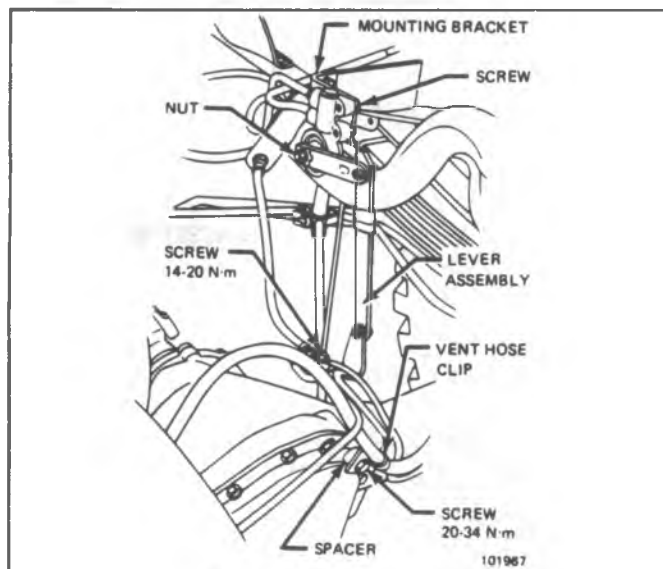

Fig. 5-18--Lever Assembly

- Remove two screws securing valve to mounting bracket and remove valve.

### Install

- Install valve on mounting bracket and tighten two screws.
- Before installing lever assembly on valve shaft, be sure all valve brackets, fasteners and links are securely attached.
  - New Valve. Install lever assembly on valve shaft by pushing plastic bushing and clip assembly over serration on valve shaft.
  - Old Valve. If original valve is being reinstalled, it must be readjusted, refer to valve adjustment procedure, axle having free wheels on.
- Install nut on shaft and tighten.
- Connect brake lines to valve.
- Bleed brake system.
- Lower vehicle and test brakes.

### Lever Assembly

#### Replacement

- Raise vehicle, axle must be allowed to hang free (no load condition).
- Remove nut from height sensing valve shaft.
- Remove lever from valve.
- Remove screw holding brake line to lever assembly.
- Remove screw securing lever assembly to axle housing and remove spacer and vent hose clip (if used).
- Remove lever assembly.
- Install spacer (if used), lever assembly, vent hose clip (if used) and secure with screw to axle housing.
- Perform Steps 3, 4, 5 and 6 of valve adjustment procedure.
- Install nut on shaft and tighten to 8-11 N·m (70-98 in. lbs.).

- Install brake line to lever assembly and secure with screw.
- Lower vehicle and check brakes.

## ROTOR SERVICING

### Lateral Runout

- Lateral runout is the movement of the rotor from side to side as it rotates on the steering knuckle spindle. This could be described as "rotor wobble".
- The movement of the rotor from side to side in the lateral plane causes the brake shoe and lining and pistons to be knocked back into their bores. This results in additional pedal travel required and a vibration during the braking action.
- To check lateral runout, first tighten the wheel bearings until all of the play is out of the bearings. Fasten a dial indicator to some portion of the suspension so that the point of the stylus contacts the rotor face approximately 1" (25 mm) from the rotor edge (Fig. 5-20). Set the dial at zero. Move the rotor one complete rotation, checking the indicator as the rotor moves.
- Lateral runout should not be over .004" (0.10 mm) total indicator reading.

### Parallelism

- Parallelism is the measurement of the thickness of the rotor at four or more points around the circumference of the rotor. All measurements must be made at the same distance in from the edge of the rotor.
- A rotor that varies over .0005" (0.013 mm) causes pedal vibration, as well as front end vibration during brake applications. A rotor that does not meet these specifications may be refinished to specifications if precision equipment is available.

### Tolerance and Surface Finish

In manufacturing the brake rotor, tolerances of the rubbing surfaces for flatness, for parallelism and for lateral runout are held very closely. The maintenance of these close controls on the shape of the rubbing surfaces is necessary to prevent brake roughness.

In addition to these tolerances, the surface finish must be held to a specified range. The control of the rubbing surface finish is necessary to avoid pulls and erratic performance and to extend lining life.

Light scoring of the rotor surfaces not exceeding .015" (0.38 mm) in depth, which may result from normal use, is not detrimental to brake operation.

### Machining

Since accurate control of the rotor tolerances is necessary for proper performance of the disc brakes, machining of the rotor should be done only with precision equipment.

**All brake rotors have a minimum thickness dimension cast into them. This dimension is the minimum wear dimension and not a refinish dimension. Do not use a brake rotor that will not meet the specifications, as shown below, after refinishing. Replace with a new brake rotor.**

### Wheel Bolt Replacement (Disc Brakes)

**NOTICE:** See "Notice" on Page 1 of this section.

- Remove hub and rotor assembly from vehicle.

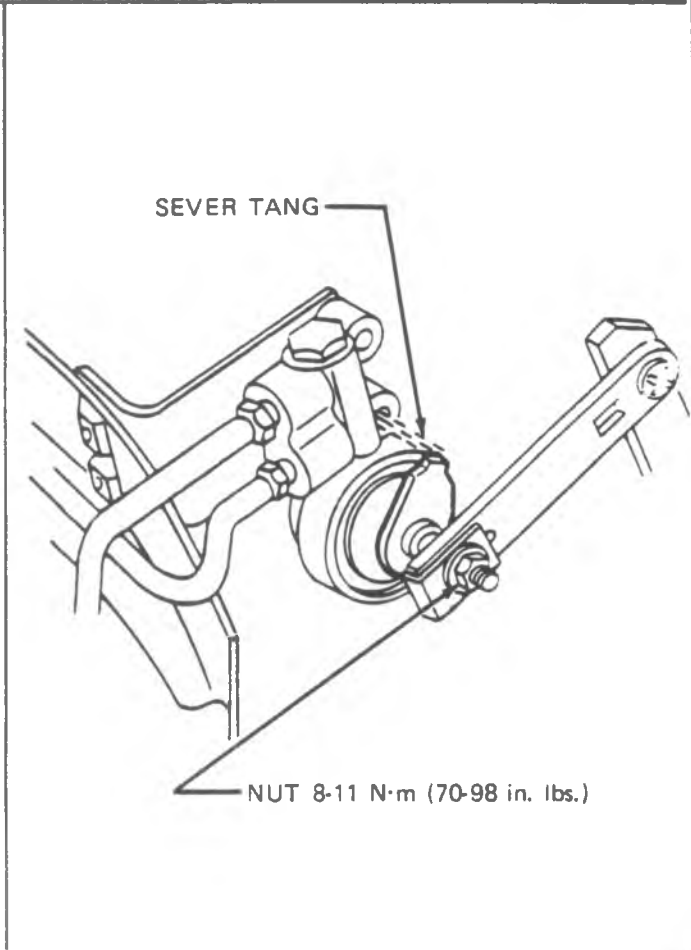
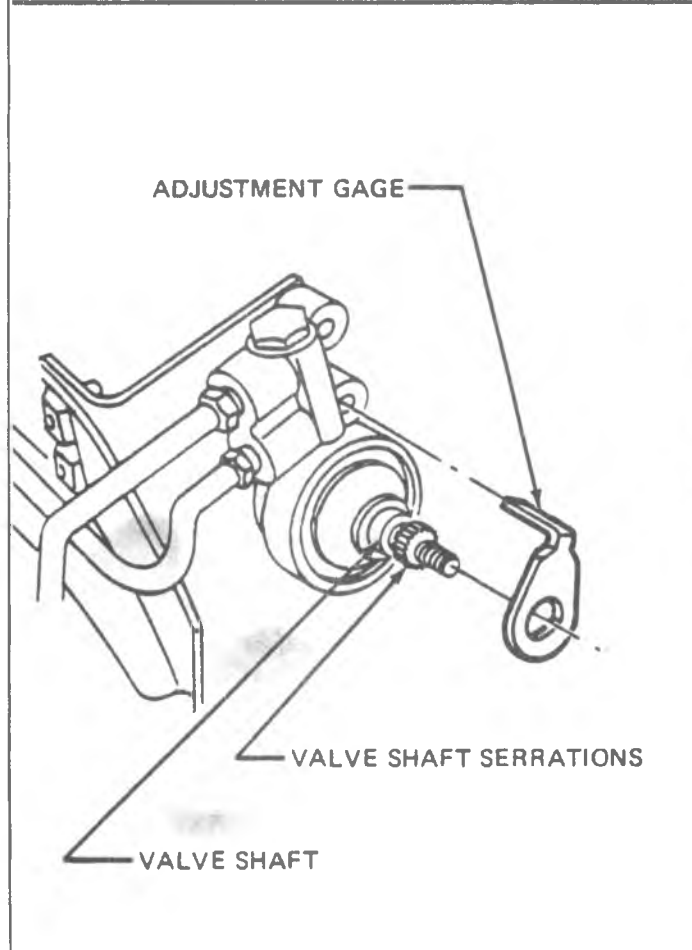
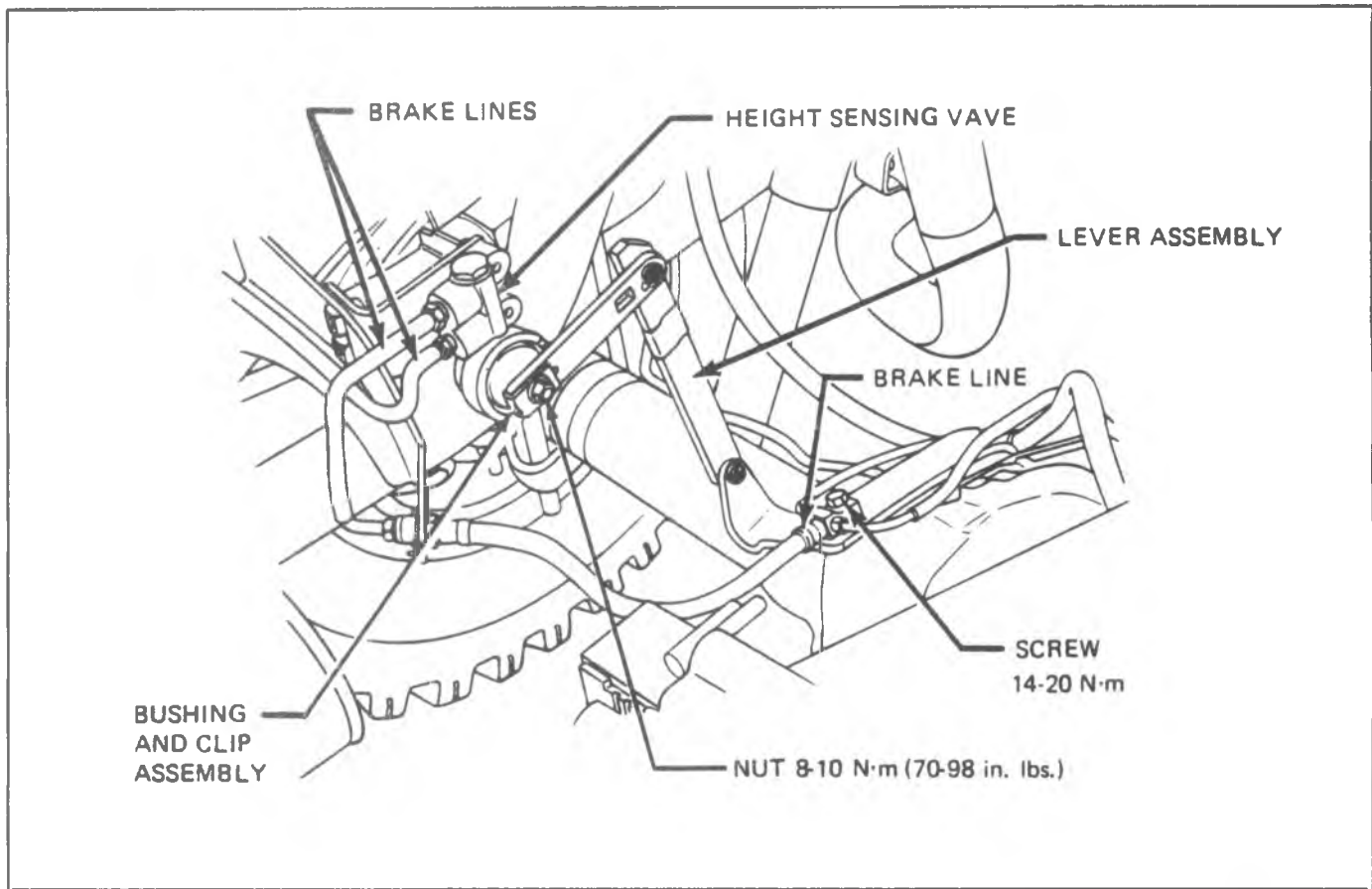

Fig. 5-19--Height Sensing Valve

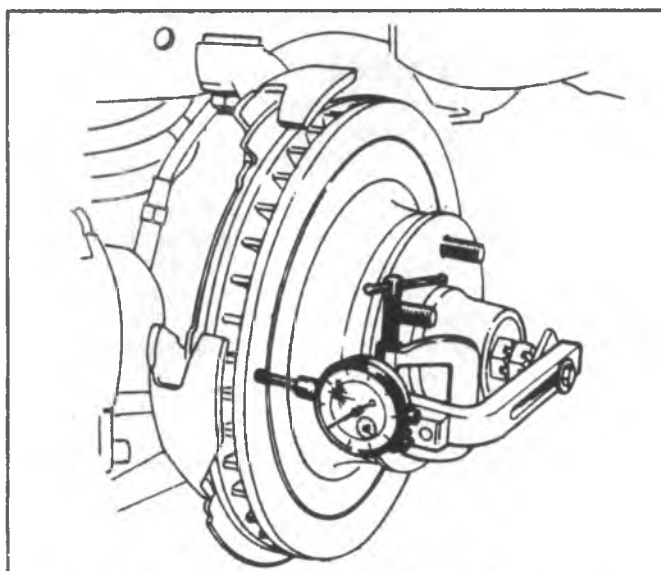

Fig. 5-20—Checking Rotor for Lateral Runout

2. Mark rotor to hub location and remove bolts attaching hub to rotor.
3. The wheel bolts on disc brakes can be pressed out from the outside of the hub and installed from inside the rotor by pressing into place. No drilling or cutting is required.
4. Reinstall assembly and adjust wheel bearings.

## BRAKE DRUMS

### Inspection and Reconditioning

**NOTICE:** See "Notice" on Page 1 of this section.

Whenever brake drums are removed, they should be thoroughly cleaned and inspected for cracks, scores, deep grooves and out-of-round.

A cracked drum is unsafe for further service and must be replaced. Do not attempt to weld a cracked drum.

Smooth up any slight scores. Heavy or extensive scoring will cause excessive brake lining wear, and it will probably be necessary to rebore in order to true up the braking surface.

If the brake linings are slightly worn and the drum is grooved, the drum should be polished with fine emery cloth but should not be turned. At this stage, eliminating the grooves in drum would necessitate removal of too much metal, while if left alone, the grooves and lining ridges match and satisfactory service can be obtained.

If brake linings are to be replaced, a grooved drum should be turned for use with new linings. A grooved drum, if used with new lining, will not only wear the lining, but will make it difficult, if not impossible to obtain efficient brake performance.

An out-of-round drum makes accurate brake shoe adjustment impossible and is likely to cause excessive wear of other parts of brake mechanism due to its eccentric action. An out-of-round drum can also cause severe and irregular tire tread wear as well as pulsating brake pedal. When the braking surface of a brake drum exceeds the

factory specification limits in taper (and/or) being out-of-round, the drum should be turned to true up the braking surface. Out-of-round as well as taper and wear can be accurately measured with an inside micrometer fitted with proper extension rods.

When measuring a drum for out-of-round, taper and wear, take measurements at the open and closed edges of machined surface and at right angles to each other.

### Turning Brake Drums

If a drum is to be turned, only enough metal should be removed to obtain a true, smooth braking surface. If a drum does not clean-up when turned to a maximum diameter as shown in the general specification, it must be replaced. Removal of more metal will affect dissipation of heat and may cause distortion of the drum.

**All brake drums have a maximum diameter cast into them. This diameter is the maximum wear diameter and not a refinish diameter. Do not refinish a brake drum that will not meet the specifications, as shown below, after refinishing.**

### Brake Drum Balance

During manufacture, brake drums are balanced. Any balance weights must not be removed.

### Propeller Shaft Brake

#### Removal (Fig. 5-21)

1. Remove the propeller shaft; See Propeller Shaft Section.
2. Remove the brake drum. It may be necessary to back off the shoe adjustment before removing the drum.
 

On automatic transmission models, the exhaust crossover pipe may be in the way. If so, loosen the transmission rear mounting bolts and jack the transmission sufficiently for brake drum to clear the pipe.
3. Remove the two pull back springs.
4. Remove the guide plate from anchor pin.
5. Remove shoe hold down cups, springs, and washers from hold down pins--remove pins.
6. Pull brake shoe and lining assemblies away from anchor pin and remove the strut and spring.
7. Lift the brake shoes and linings with the adjusting nut and bolt and connecting spring off the flange plate.
8. Move the shoes toward each other until the adjusting bolt and connecting spring drop off.
9. Remove the clip holding the brake lever to the primary shoe (shoe with short lining).
10. Compress the spring on the brake cable and remove the cable from the lever.
11. If necessary to remove the anchor pin, straighten the washer from pin hex and reinforcement. Remove reinforcement and washer with anchor pin.
12. If necessary to remove the cable, compress tangs on cable and pull assembly out of the hole in the flange plate.
13. If necessary to remove the flange plate, remove the transmission flange nut and transmission output flange. Remove bolts holding the flange plate to bearing retainer and remove the flange plate.

## CONVENTIONAL DRUM BRAKE ASSEMBLY

### GENERAL DESCRIPTION

This drum brake assembly is a duo-servo design. In the duo-servo brake, the force which the wheel cylinder applies to the primary shoe is multiplied by the primary lining friction to provide a very large force applied to the secondary shoe. Torque from the brake shoes is transferred to anchor pin and through the backing plate, to the axle flange. Adjustment is automatic during reverse brake applications.

**NOTICE:** Replace all components included in repair kits used to service this drum brake. Lubricate parts as specified. Replace shoe and lining in axle sets only. If any hydraulic component is

removed or brake line disconnected, bleed the brake system. The torque values specified are for dry, unlubricated fasteners.

**CAUTION:** When servicing wheel brake parts, do not create dust by grinding or sanding brake linings or by cleaning wheel brake parts with a dry brush or with compressed air. (A water dampened cloth should be used.) Many wheel brake parts contain asbestos fibers which can become airborne if dust is created during servicing. Breathing dust containing asbestos fibers may cause serious bodily harm.

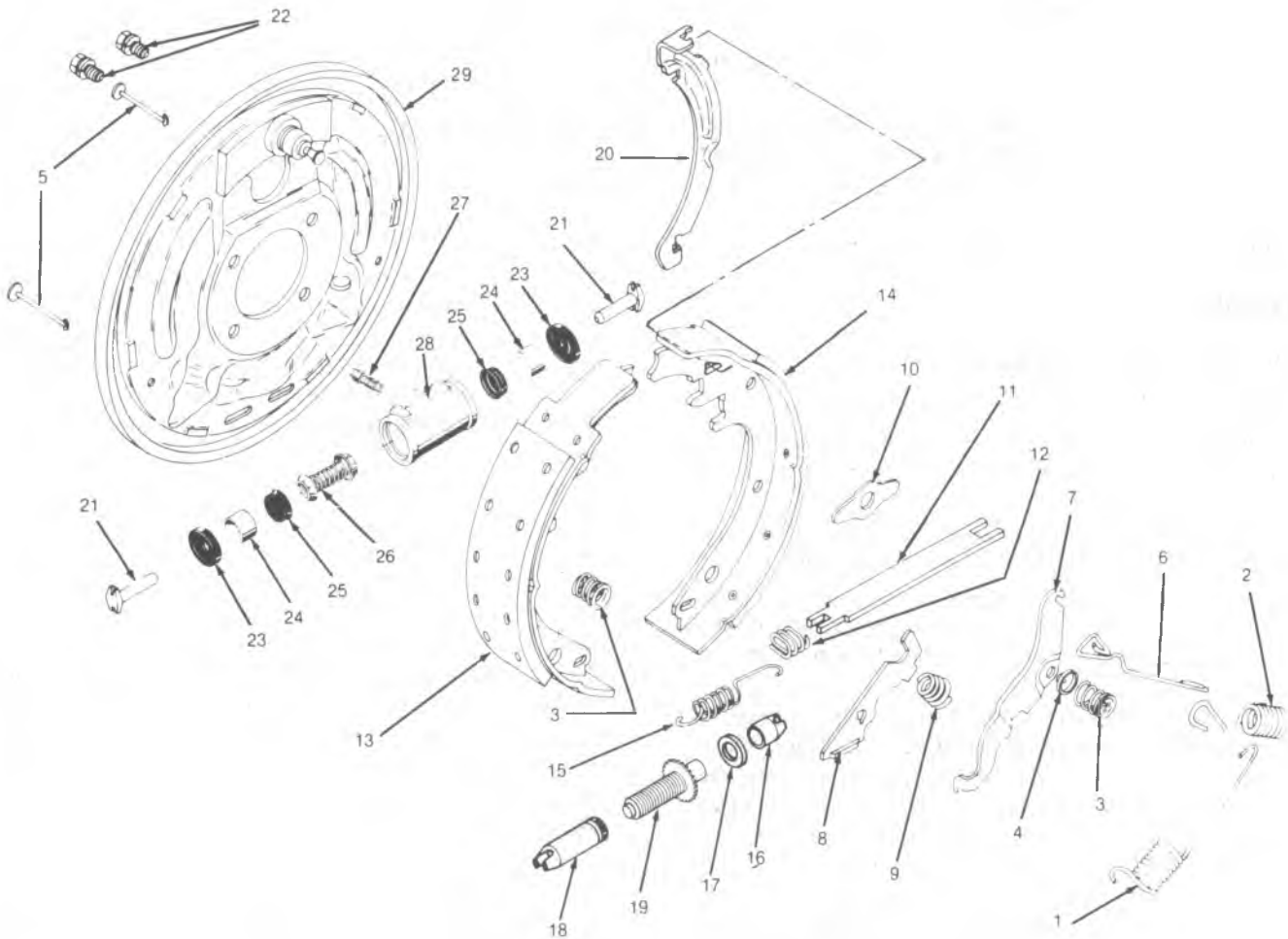

- 1. Return spring
- 2. Return spring
- 3. Hold-down spring
- 4. Lever pivot
- 5. Hold-down pin
- 6. Actuator link
- 7. Actuator lever
- 8. Pawl
- 9. Lever return spring
- 10. Shoe guide
- 11. Parking brake strut

- 12. Strut spring
- 13. Primary shoe
- 14. Secondary shoe
- 15. Adjusting screw spring
- 16. Socket
- 17. Washer
- 18. Pivot nut
- 19. Adjusting screw
- 20. Parking brake lever
- 21. Cylinder link

- 22. Bolt
- 23. Boot
- 24. Piston
- 25. Seal
- 26. Spring assembly
- 27. Bleeder valve
- 28. Cylinder body
- 29. Backing plate
- 30. Wheel cylinder assembly
- 31. Adjusting screw assembly

**1. REMOVE AND INSTALL BRAKE COMPONENTS.**

**REMOVE**

1. Hoist car and mark relationship of wheel to axle. Remove wheel.
2. Mark relationship of drum to axle and remove drum.
3. Remove return springs (1 and 2) using brake spring pliers J-8049.
4. Remove hold-down springs (3) using suitable pliers. Remove lever pivot (4).
5. Remove hold-down pins (5).
6. Lift up on actuator lever (7) and remove actuating link (6).
7. Remove actuator lever (7), pawl (8) and return spring (9).
8. Remove shoe guide (10).
9. Remove parking brake strut (11) and spring (12) by spreading shoes apart.
10. Spread shoe and lining assemblies (13 and 14) to clear axle flange. Disconnect parking brake cable and remove shoes, connected by spring (15), from vehicle.
11. Remove adjusting screw assembly (31) and spring (15) (Note position of Adjusting Spring). Do not interchange adjusting screws from RH and LH brake assemblies.
12. Remove parking brake lever (20) by unhooking lever tab from shoe (14) slot.

**NOTICE:** If any parts are of doubtful strength or quality due to discoloration from heat, over-stress, or are worn, the part(s) should be replaced.

**INSTALL**

SEE NOTICE ON PAGE 5-1 OF THIS SECTION.

1. Install parking brake lever (20) by hooking lever tab into shoe (14) slot as shown.
2. Inspect adjusting screw (19) threads for smooth rotation over full length as shown in A. Clean in fresh brake fluid. Apply brake lube to screw (19) threads, inside diameter of socket (16) and socket face. Adequate lubrication is achieved when a continuous bead of lubricant is produced at open end of pivot nut (18) and socket (16) after parts are assembled and threads fully engaged.
3. Install adjusting screw assembly (31) and spring (15) as shown in A. Coils of spring must not be over star wheel. Left and right hand springs are different. **DO NOT** interchange.
4. Spread shoe and lining assemblies (13 and 14) to clear axle flange. connect parking brake cable, and install parts on vehicle.
5. Install parking brake strut (11) and spring (12) by spreading shoes (13 and 14) apart.
6. Make sure that strut (11) is properly positioned. The end without the spring (12) engages the parking brake lever (20). The end with the spring engages the opposite shoe (13 or 14).
7. Install shoe guide (10).
8. Install pawl (8), actuator lever (7) and return spring (9).
9. Install hold-down pins (5), lever pivot (4), and hold-down springs (3).
10. Install actuating link (6) on anchor pin (32).
11. Lift up on actuator lever (7) and hook link (6) into lever.
12. Install shoe return springs (1 and 2) using brake spring pliers J-8057.

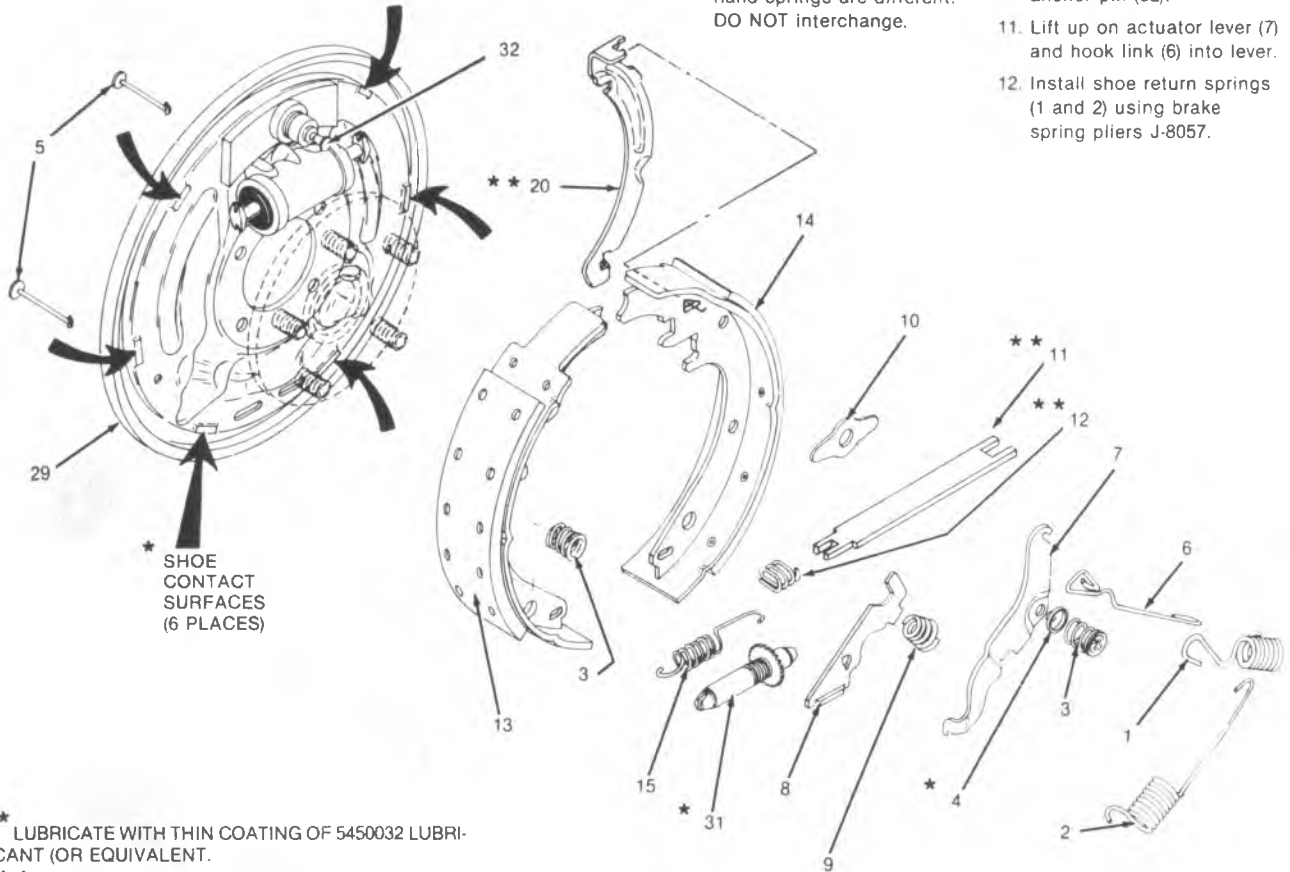

\* SHOE CONTACT SURFACES (6 PLACES)

\* LUBRICATE WITH THIN COATING OF 5450032 LUBRICANT (OR EQUIVALENT).

\*\*\* SOME CARS: PARKING BRAKE LEVER INSTALLED ON PRIMARY SHOE FOR RH ASSEMBLIES. TURN PARKING BRAKE STRUT AND SPRING END FOR END FROM POSITION SHOWN.

- |                     |                         |                              |
|---------------------|-------------------------|------------------------------|
| 1. Return spring    | 8. Pawl                 | 14. Secondary shoe           |
| 2. Return spring    | 9. Lever return spring  | 15. Adjusting screw spring   |
| 3. Hold-down spring | 10. Shoe guide          | 20. Parking brake lever      |
| 4. Lever pivot      | 11. Parking brake strut | 29. Backing plate            |
| 5. Hold-down pin    | 12. Strut spring        | 31. Adjusting screw assembly |
| 6. Actuator link    | 13. Primary shoe        | 32. Anchor pin               |

A

\* LUBRICATE WITH THIN COATING OF 5450032 LUBRICANT (OR EQUIVALENT).

PROPER SPRING INSTALLATION

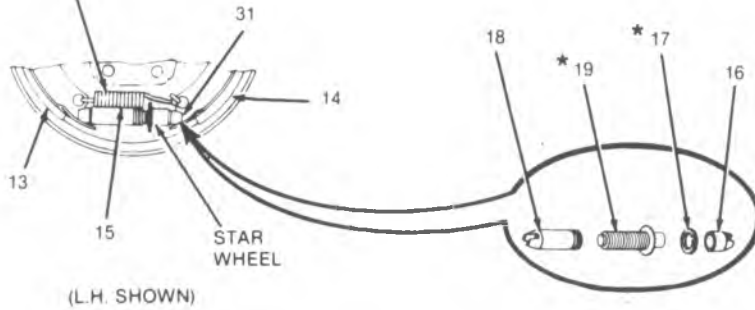

(L.H. SHOWN)

- 13. Primary shoe
- 14. Secondary shoe
- 15. Adjusting screw spring
- 16. Socket
- 17. Washer
- 18. Pivot nut
- 19. Screw
- 31. Adjusting screw assembly

**2. REMOVE AND INSTALL WHEEL CYLINDER.**

**REMOVE**

1. Remove dirt and foreign material around wheel cylinder (30) inlet and pilot.
2. Remove links (21) and disconnect inlet tube line.
3. Remove wheel cylinder bolts (22) and lift off wheel cylinder (30).

**INSTALL**

SEE NOTICE ON PAGE 5-1 OF THIS SECTION

1. Position wheel cylinder (30) and attach with bolts (22).
2. Torque bolts (22) to 11.3-25.4 N-m (100-225 lb-in).
3. Torque inlet tube nut to 13.6-20.3 N-m (120-280 in-lb).

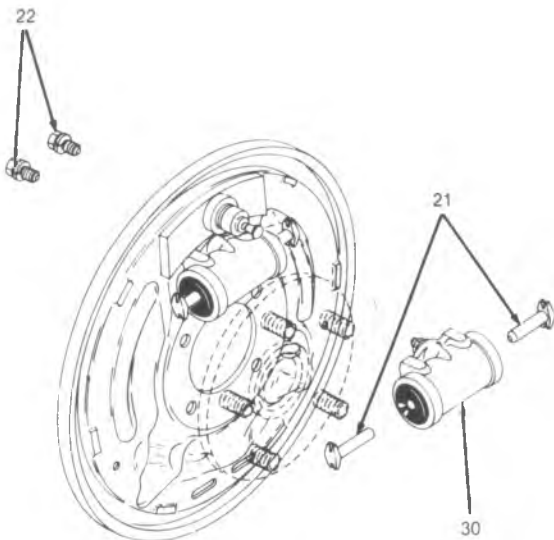

- 21. Cylinder link
- 22. Bolt
- 30. Wheel cylinder

**3. DISASSEMBLE AND ASSEMBLE WHEEL CYLINDER.**

**DISASSEMBLE**

1. Disassemble parts as shown.
2. Clean wheel cylinder body (28) in fresh brake fluid.
3. Use dry, filtered compressed air to remove excess fluid from wheel cylinder body (28) and to blow out passages.
4. Inspect cylinder bore for scoring and corrosion. Crocus cloth may be used to remove light corrosion and stains. Replace wheel cylinder assembly if crocus cloth does not remove corrosion or if bore is scored.

**ASSEMBLE**

SEE NOTICE ON PAGE 5-1 OF THIS SECTION

1. Lubricate new seals (25) with clean brake fluid.
2. Assemble as shown, new seals (25), new boots (23) and new spring assembly (26), with wheel cylinder piston (24).
3. Torque bleeder screw (27) to 4.5-10.2 N-m (40-90 in-lb).

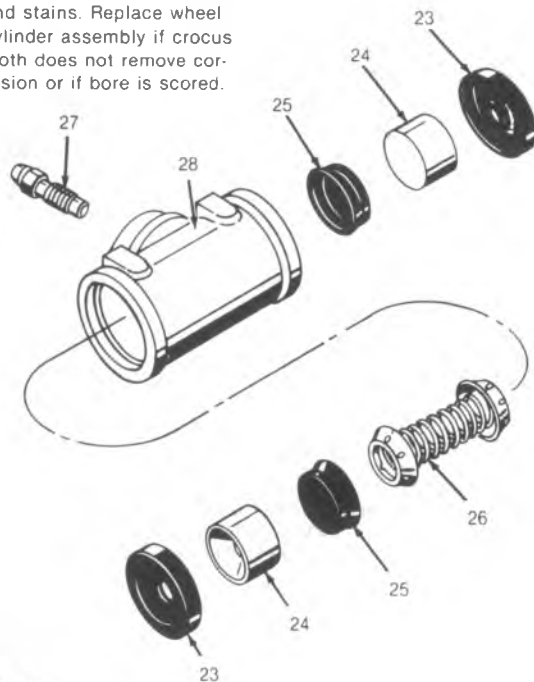

- 23. Boot
- 24. Piston
- 25. Seal
- 26. Spring assembly
- 27. Bleeder valve
- 28. Cylinder body

## DIRECT TORQUE DRUM BRAKE ASSEMBLY

### GENERAL DESCRIPTION

This drum brake assembly is a duo-servo, direct torque design. In the duo-servo design, the force which the wheel cylinder applies to the primary shoe is multiplied by the primary lining friction to provide a very large force applied to the secondary shoe. With direct torque design, torque from the brake shoes is transferred directly through the anchor pin to the axle flange. Adjustment is automatic during reverse brake applications.

**NOTICE:** Replace all components included in repair kits used to service this drum brake. Lubricate parts as specified. Replace shoe and lining in axle sets only. If any hydraulic component is

removed or brake line disconnected, bleed the brake system. The torque values specified are for dry, unlubricated fasteners.

**CAUTION:** When servicing wheel brake parts, do not create dust by grinding or sanding brake linings or by cleaning wheel brake parts with a dry brush or with compressed air. (A water dampened cloth should be used.) Many wheel brake parts contain asbestos fibers which can become airborne if dust is created during servicing. Breathing dust containing asbestos fibers may cause serious bodily harm.

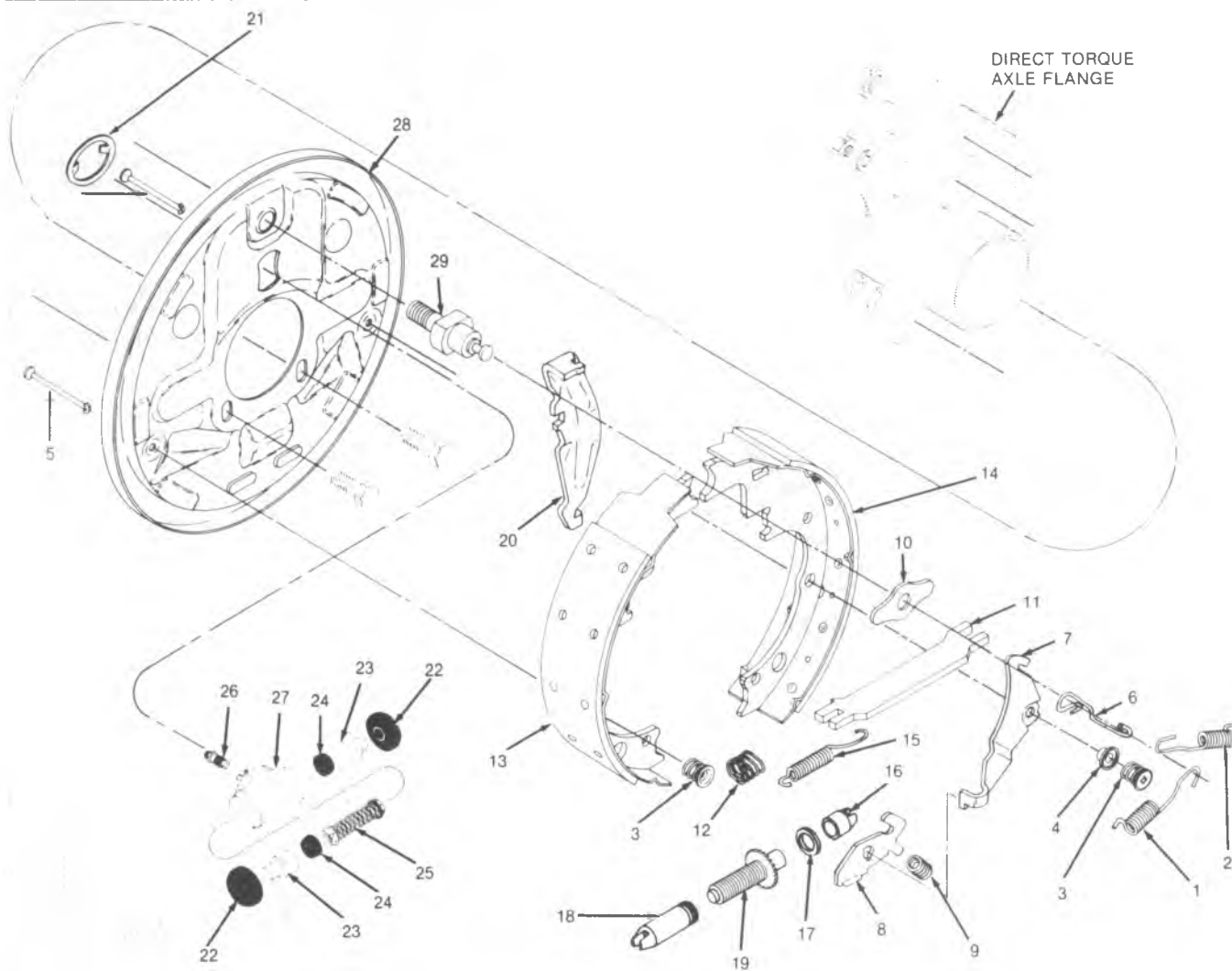

- |                     |                         |                             |                     |
|---------------------|-------------------------|-----------------------------|---------------------|
| 1. Return spring    | 8. Pawl                 | 15. Adjusting screw spring  | 22. Boot            |
| 2. Return spring    | 9. Lever return spring  | 16. Socket                  | 23. Piston          |
| 3. Hold-down spring | 10. Shoe guide          | 17. Washer                  | 24. Seal            |
| 4. Lever pivot      | 11. Parking brake strut | 18. Pivot nut               | 25. Spring assembly |
| 5. Hold-down pin    | 12. Strut spring        | 19. Adjusting screw         | 26. Bleeder valve   |
| 6. Actuator link    | 13. Primary shoe        | 20. Parking brake lever     | 27. Cylinder body   |
| 7. Actuator lever   | 14. Secondary shoe      | 21. Wheel cylinder retainer | 28. Backing plate   |
|                     |                         |                             | 29. Anchor pin      |

LH ASSEMBLY



1. REMOVE AND INSTALL BRAKE COMPONENTS.

REMOVE

1. Hoist car and mark relationship of wheel to axle. Remove wheel.
2. Mark relationship of drum to axle and remove drum.
3. Remove return springs (1 and 2) using brake spring pliers J-8049.
4. Remove hold-down springs (3) using suitable pliers. Remove lever pivot (4).
5. Remove hold-down pins (5).
6. Lift up on actuator lever (7) and remove actuating link (6).
7. Remove actuator lever (7), pawl (8) and return spring (9).
8. Remove shoe guide (10).
9. Remove parking brake strut (11) and spring (12) by spreading shoe (13 and 14) apart.
10. Spread shoe and lining assemblies (13 and 14) to clear axle flange. Disconnect parking brake cable and remove shoes, connected by spring (15), from vehicle.
11. Remove adjusting screw assembly (31) and spring (15) (Note position of Adjusting Spring). Do not interchange adjusting screws from RH and LH brake assemblies.
12. Remove parking brake lever (20) from secondary shoe (14) by unhooking lever tab from shoe slot.

NOTICE: If any parts are of doubtful strength or quality due to discoloration from heat, over-stress, or are worn, the part(s) should be replaced.

INSTALL

SEE NOTICE ON PAGE 5-1 OF THIS SECTION.

1. Install parking brake lever (20) on secondary shoe (14) by hooking lever tab into shoe slot as shown.
2. Inspect adjusting screw (19) threads for smooth rotation over full length as shown in A. Clean in fresh brake fluid. Apply brake lube to screw threads, inside diameter of socket (16) and socket face. Adequate lubrication is achieved when a continuous bead of lubricant is produced at open end of pivot nut (18) and socket (16) after parts are assembled and threads fully engaged.
3. Install adjusting screw assembly (31) and spring (15) as shown in A. Coils of spring must not be over star wheel. Left and right hand springs are different. DO NOT interchange.

4. Spread shoe and lining assemblies (13 and 14) to clear axle flange, connect parking brake cable, and install parts on vehicle.
5. Install parking brake strut (11) and spring (12) by spreading shoes apart.
6. Make sure that strut (11) is properly positioned. The end without the spring (12) engages the parking brake lever (20). The end with the spring engages the primary shoe (13).
7. Install shoe guide (10).
8. Install pawl (8), actuator lever (7) and return spring (9).
9. Install hold-down pins (5), lever pivot (4), and hold-down springs (3).
10. Install actuating link (6) on anchor pin (29).
11. Lift up on actuator lever (7) and hook link (6) into lever.
12. Install shoe return springs (1 and 2) using brake spring pliers J8057.

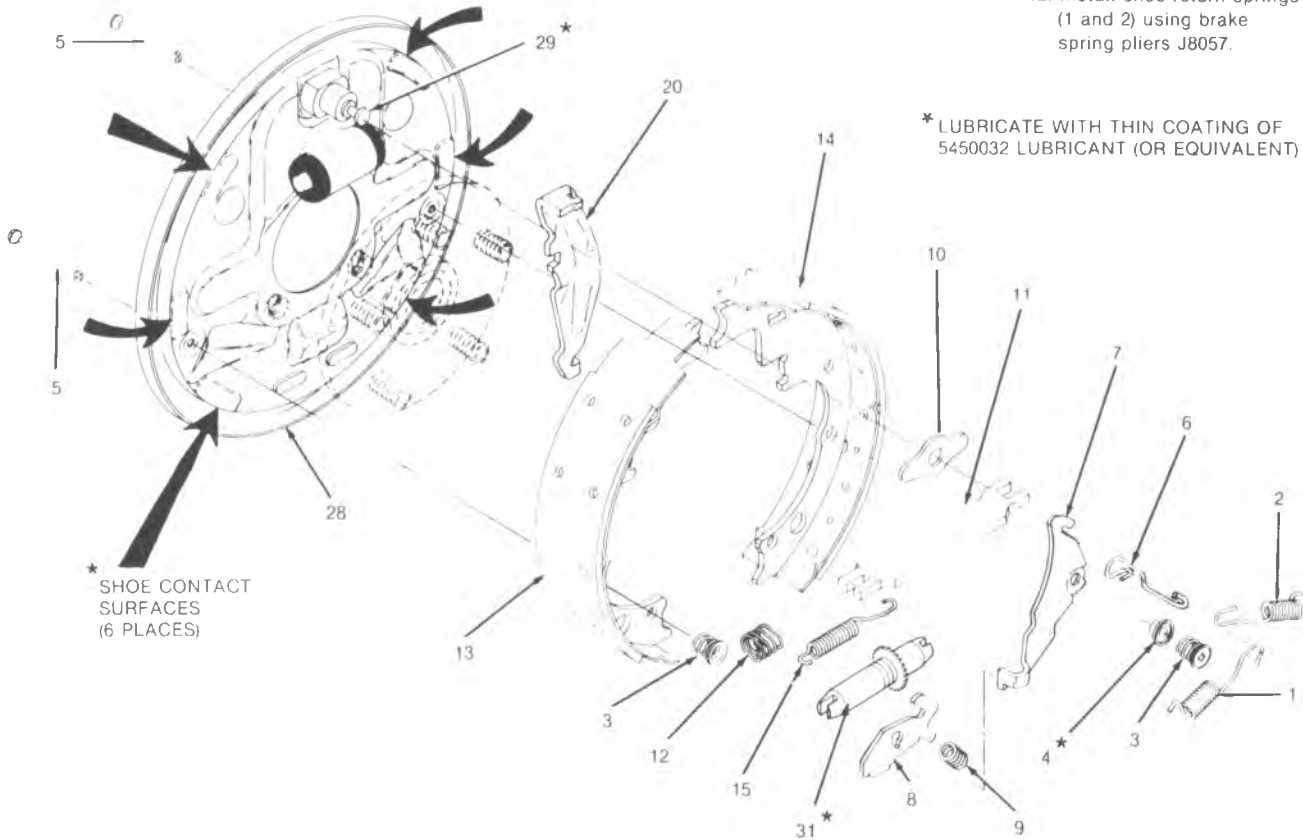

\* LUBRICATE WITH THIN COATING OF 5450032 LUBRICANT (OR EQUIVALENT)

\* SHOE CONTACT SURFACES (6 PLACES)

- |                     |                        |                            |                              |
|---------------------|------------------------|----------------------------|------------------------------|
| 1. Return spring    | 6. Actuator link       | 11. Parking brake strut    | 20. Parking brake lever      |
| 2. Return spring    | 7. Actuator lever      | 12. Strut spring           | 28. Backing plate            |
| 3. Hold-down spring | 8. Pawl                | 13. Primary shoe           | 29. Anchor pin               |
| 4. Lever pivot      | 9. Lever return spring | 14. Secondary shoe         | 31. Adjusting screw assembly |
| 5. Hold-down pin    | 10. Shoe guide         | 15. Adjusting screw spring |                              |



A

PROPER SPRING  
INSTALLATION

\* LUBRICATE WITH THIN COATING OF  
5450032 LUBRICANT (OR EQUIVALENT)

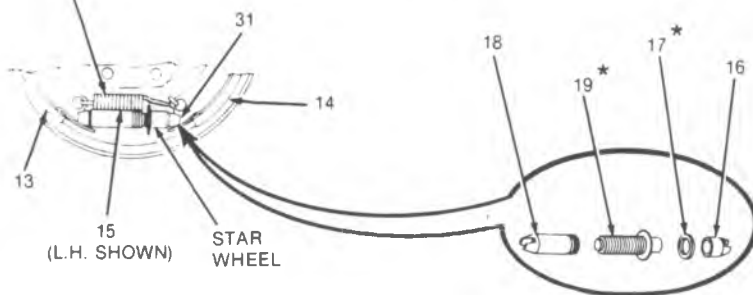

- 13. Primary shoe
- 14. Secondary shoe
- 15. Adjusting screw spring  
(L.H. SHOWN)
- 16. Socket
- 17. Washer
- 18. Pivot nut
- 19. Adjusting screw
- 31. Adjusting screw assembly

**2. REMOVE AND INSTALL WHEEL CYLINDER.**

**REMOVE**

1. Remove dirt and foreign material around wheel cylinder (30) inlet and pilot.
2. Disconnect inlet tube line.
3. Remove wheel cylinder retainer (21) using two awls (32) or pins (1/8 inch diameter or less).
4. Insert awls (32) or pins into access slots between wheel cylinder pilot and retainer (21) locking tabs as shown in A. (Tool J-29839 may be used to remove retainer.)
5. Bend both tabs away simultaneously.

**INSTALL**

SEE NOTICE ON PAGE 5-1 OF THIS SECTION.

1. Position wheel cylinder (30) and hold in place with wooden block between cylinder and axle flange.
2. Install new retainer (21) over wheel cylinder (30) abutment using a 1-1/8 inch, 12 point socket (34) and socket extension (33) as shown in B.
3. Torque inlet tube nut to 13.6-20.3 N-m (120-280 in-lb).

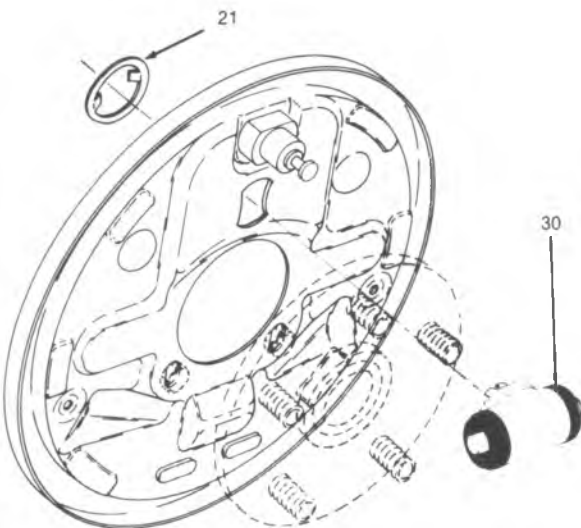

21. Wheel cylinder retainer

30. Wheel cylinder

A

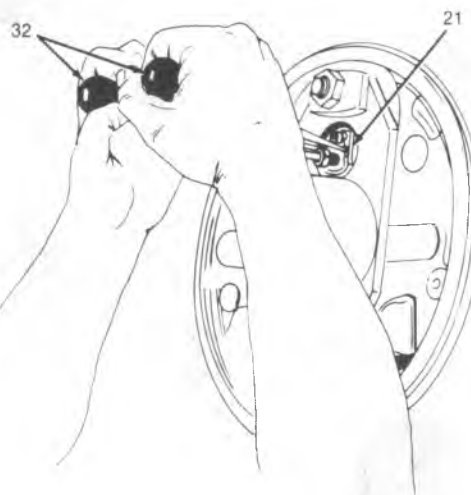

21. Wheel cylinder retainer

32. Awl

B

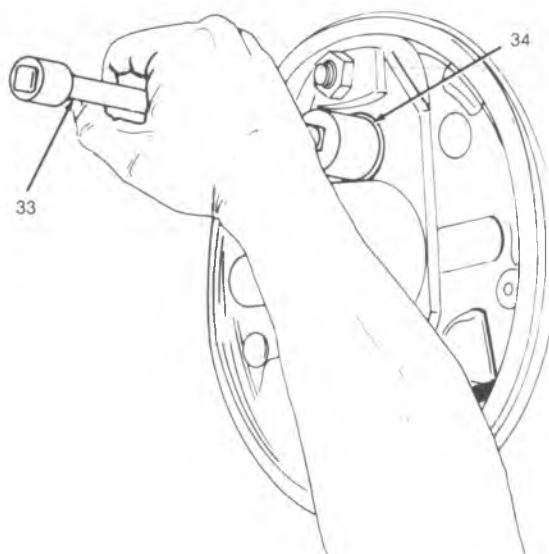

33. Socket extension

34. 1-1/8 in., 12 pt. socket

### 3. DISASSEMBLE AND ASSEMBLE WHEEL CYLINDER.

#### DISASSEMBLE

1. Disassemble parts as shown.
2. Clean wheel cylinder body (27) in fresh brake fluid.
3. Use dry, filtered compressed air to remove excess fluid from wheel cylinder body (27) and to blow out passages.
4. Inspect cylinder (27) bore for scoring and corrosion. Crocus cloth may be used to remove light corrosion and stains. Replace wheel cylinder assembly if crocus cloth does not remove corrosion or if bore is scored.

#### ASSEMBLE

SEE NOTICE ON PAGE 5-1 OF THIS SECTION.

1. Lubricate new seals (24) with clean brake fluid.
2. Assemble as shown, new seals (24), new boots (22) and new spring assembly (25), with wheel cylinder pistons (23).
3. Torque bleeder screw (26) to 3.4-7.9 N-m (30-70 in-lb).

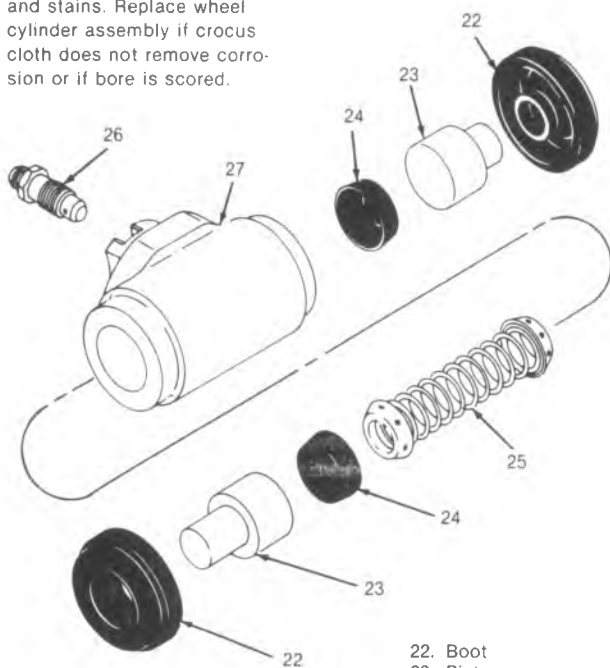

- 22. Boot
- 23. Piston
- 24. Seal
- 25. Spring Assembly
- 26. Bleeder valve
- 27. Cylinder body

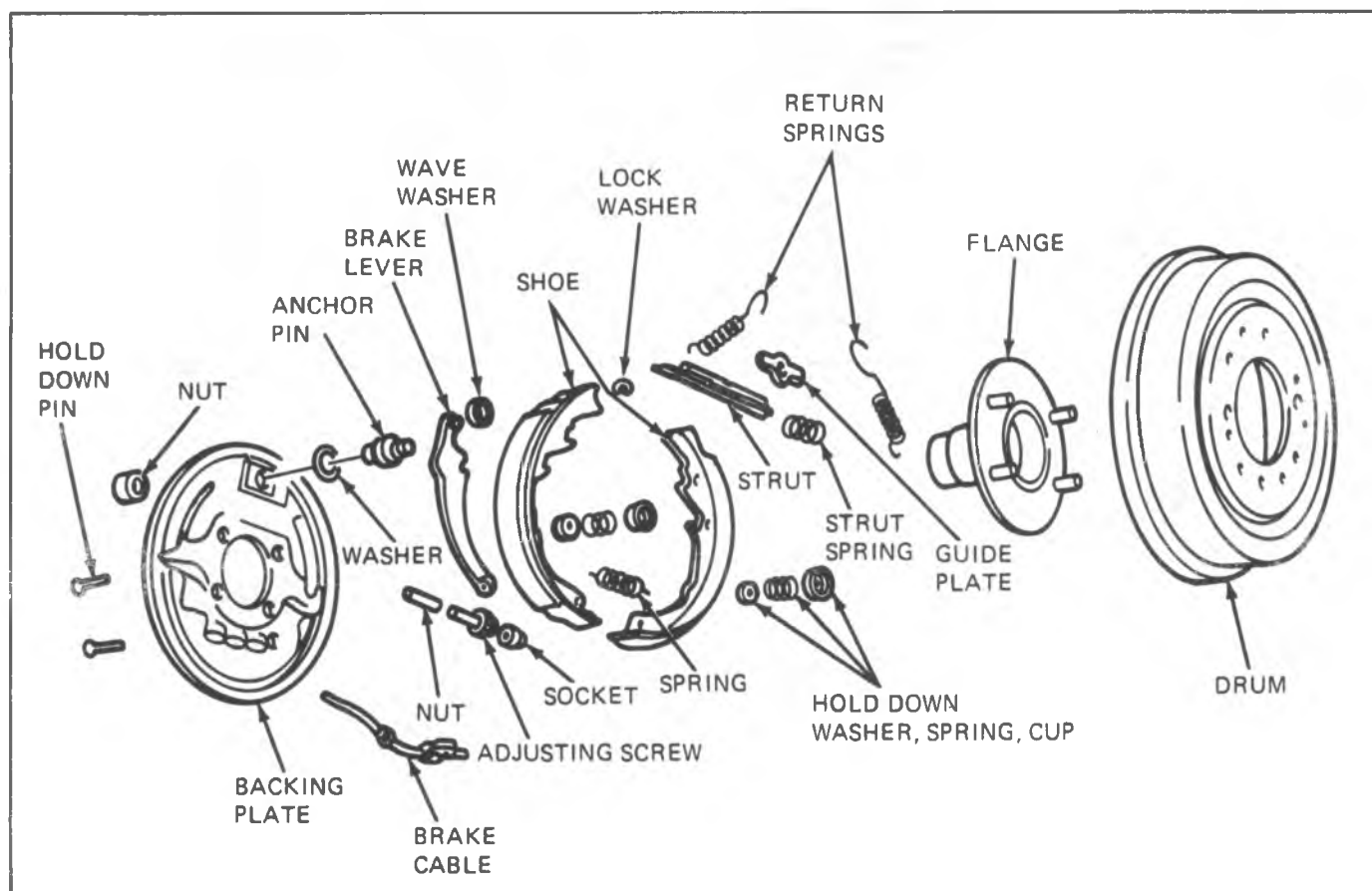

Fig. 5-21--Propshaft Parking Brake Components

**Inspection**

Replace any worn or broken parts.

**Installation**

**NOTICE:** Refer to "Notice" on Page 1 of this section when installing fasteners in Steps 1, 2 and 4 below.

1. Place the flange plate in position on the rear bearing retainer and fasten with four bolts. Torque bolts to 24 lb. ft. (33 N·m).
2. Install transmission output flange on spline of mainshaft and fasten with flange nut. Torque nut to 100 lb. ft. (136 N·m).
3. Install cable assembly from back of flange plate. Push retainer through hole in flange plate until tangs securely grip the inner side of the plate.
4. Place washer and reinforcement over the threaded end of anchor pin. Hold anchor pin nut (flat side against flange on flange plate) in position behind flange plate and insert threaded end of anchor pin from front side. Thread the anchor pin into nut and tighten securely (140 lb. ft.--190 N·m). Bend tang of washer over reinforcement and side of washer over hex of anchor pin.
5. Install lever on cable by compressing spring and inserting cable in channel of lever. Release spring.
6. Install primary shoe (short lining) to lever as follows: Place pin in lever, place washer on pin and push pin through hole in primary shoe. Fasten parts together by installing the clip in groove of pin.
7. Fasten two brake shoes and linings together by installing connecting spring. Move the shoes toward each other and install adjusting screw.
8. Lubricate the flange plate contact surfaces with a very light coat of Delco Brake Lube (or equivalent).
9. Place shoe and linings in position on flange plate. When facing the brake assembly, the shoe with the short lining should be to the left with the lever assembled to it (automatic transmission), to the right (manual transmission).
10. Pull brake shoes apart and install strut lever and spring between them. The loop on the strut spring should be in the "up" position.
11. Install hold down pins, washers, springs and cups from flange plate to shoes.
12. Place guide plate on anchor pin.
13. Install pull back springs.
14. Remove the "knock out" plug (if necessary) and install a new metal plug in the brake drum adjusting hole.
15. Install the brake drum.
16. Install the propeller shaft.

## DISC BRAKE CALIPER ASSEMBLY - 3000/3100 SERIES

### GENERAL DESCRIPTION

This caliper has a single bore and is mounted to the support bracket with two mounting bolts. Hydraulic force, created by applying force to the brake pedal, is converted by the caliper to friction. The hydraulic force acts equally against the piston and the bottom of the caliper bore to move the piston outward and to move (slide) the caliper inward resulting in a clamping action on the rotor. This clamping action forces the linings against the rotor creating friction to stop the vehicle.

**NOTICE:** Replace all components included in repair kits used to service the caliper. Lubricate parts as specified. Do not use lubricated shop air on brake parts as damage to rubber components may result. If any component is removed or line disconnected, bleed the brake system. Replace shoe and linings in axle sets only. The torque values specified are for dry, unlubricated fasteners.

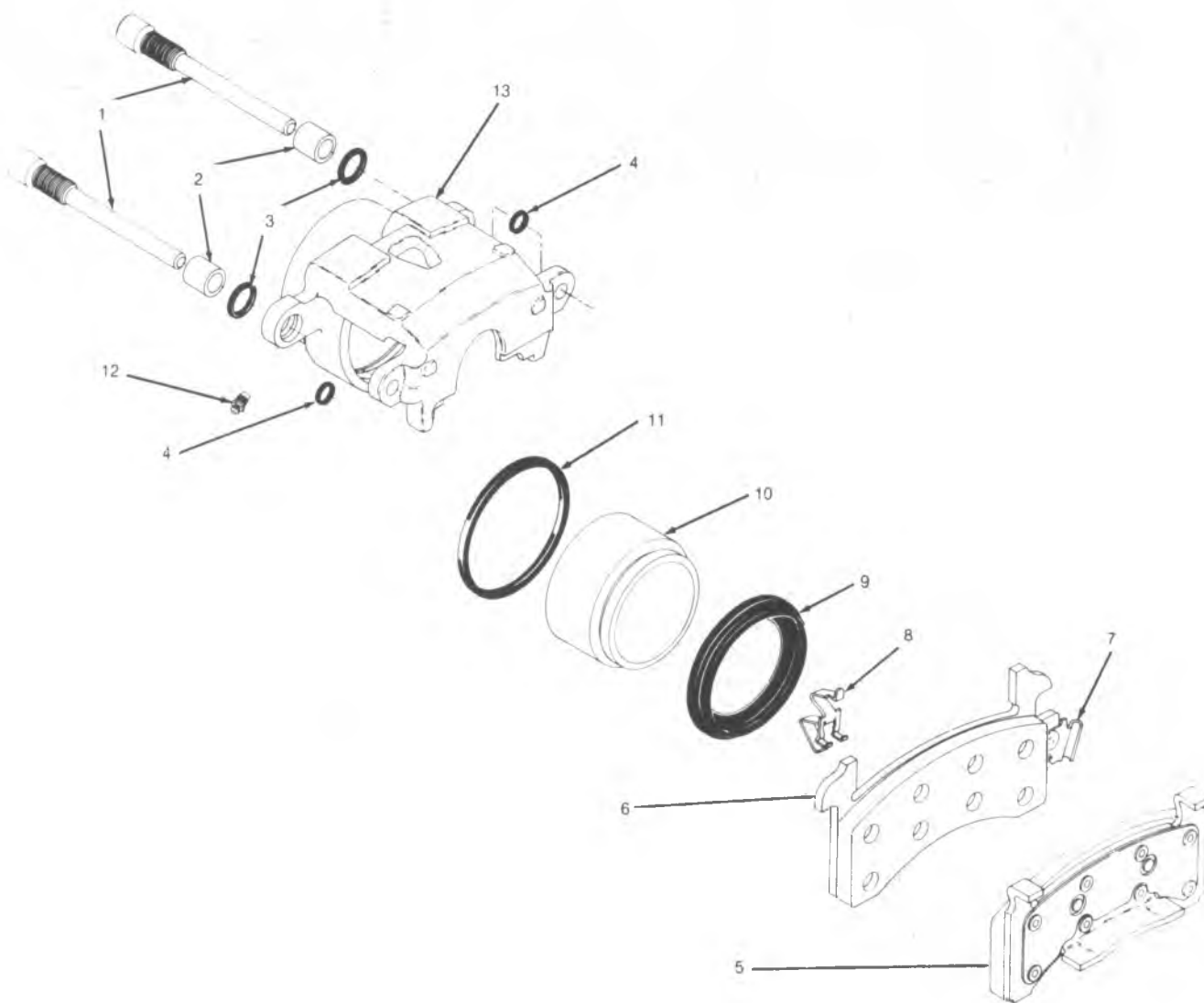

- 1 Mounting bolt
- 2 Sleeve
- 3 Bushing
- 4 Bushing

- 5 Outboard shoe & lining
- 6 Inboard shoe & lining
- 7 Wear sensor

- 8 Shoe retainer spring
- 9 Boot
- 10 Piston

- 11 Piston seal
- 12 Bleeder screw
- 13 Caliper housing

**1. REMOVE AND INSTALL CALIPER ASSEMBLY.**

**REMOVE**

1. Remove 2/3 of brake fluid from master cylinder assembly.
2. Hoist car and mark relationship of wheel to axle. Remove wheel. Reinstall two lug nuts to hold rotor in place.
3. Position C-clamp (14) as shown in A and tighten until piston bottoms in bore.
4. Remove C-clamp (14).
5. Remove bolt holding inlet fitting (15) as shown in B (if only shoe and lining are being replaced, do not remove inlet fitting).
6. Remove allen head mounting bolts (1) shown in B.
7. Inspect mounting bolts for corrosion. If corrosion is found, use new bolts when installing caliper. Do not attempt to polish away corrosion.

8. If only shoe and linings are being replaced, remove caliper (13) from rotor and suspend with a wire hook (17) from front frame or suspension as shown in C.

**INSTALL**

SEE NOTICE ON PAGE 5-1 OF THIS SECTION

1. Position caliper (13) over rotor in mounting bracket (18).
2. Install mounting bolts (1) and torque to 28-47 N-m (21-35 ft-lb).
3. Check clearance between caliper (13) and bracket (18) stops as shown in D. If necessary, file ends of bracket stops (18) to provide proper clearance.
4. Install inlet fitting (15) (if removed) and torque to 24-40 N-m (18-30 ft-lb).
5. Install wheels and lower car.
6. Fill master cylinder to proper level. Bleed brakes if inlet fitting was removed.

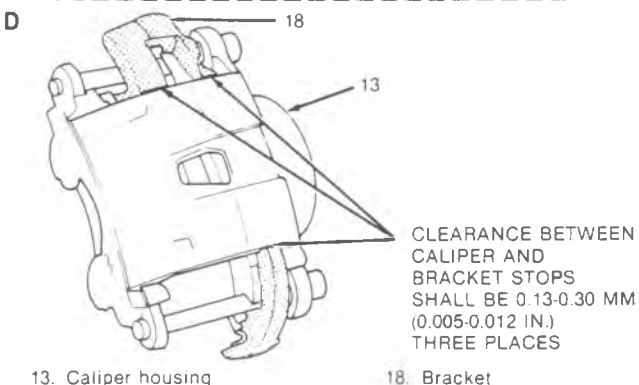
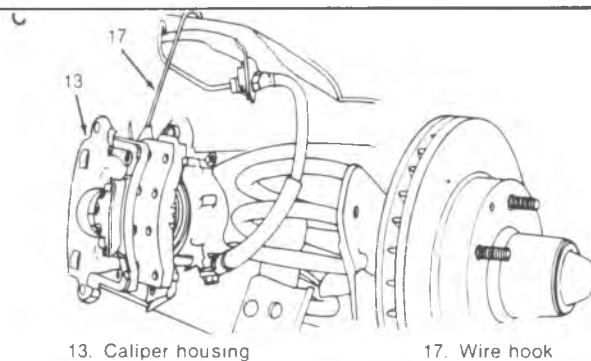
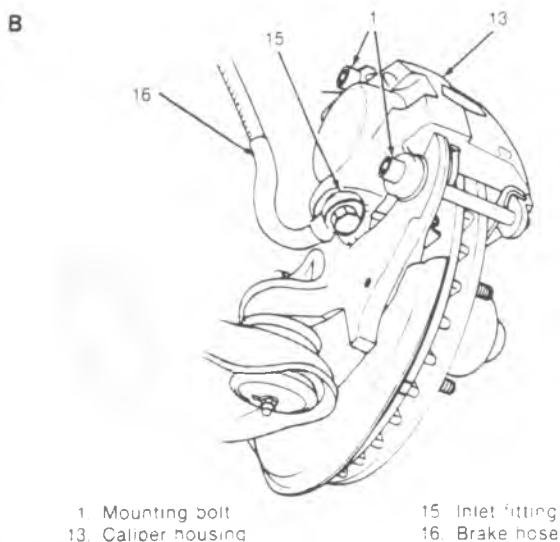
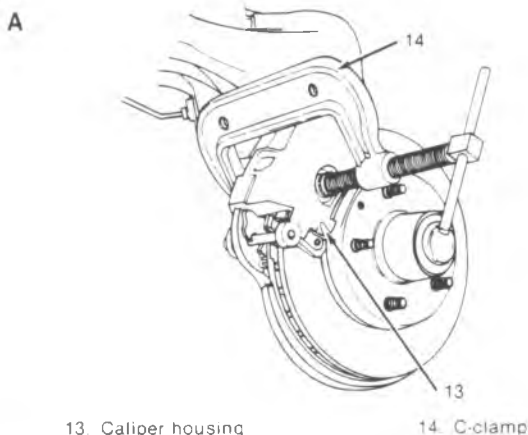

**2. REMOVE AND INSTALL SHOE AND LINING ASSEMBLIES.**

**REMOVE**

1. Remove shoe and lining assemblies (5 and 6) from caliper.
2. Remove sleeves (2) from mounting bolt holes.
3. Remove bushings (3 and 4) from grooves in mounting bolt holes.
3. Install retainer spring (8) on inboard shoe (6) as shown in A.
4. Install inboard shoe and lining (6) as shown in B with wear sensor (7) at leading edge of shoe during forward wheel rotation.

**INSTALL**

1. lubricate and install new bushings (3 and 4) in grooves in mounting bolt holes.
2. lubricate and install new sleeves (2) in mounting bolt holes.
5. Install outboard shoe and lining (5) as shown in C.
6. Install caliper as specified in procedure 1. After installation of calipers, apply approximately 778 N (175 lb) of force three times to brake pedal.
7. Position 12-inch channel-lock pliers (19) over brake shoe ears and bottom edge of caliper (13) as shown in D. Clinch shoe ears to caliper.

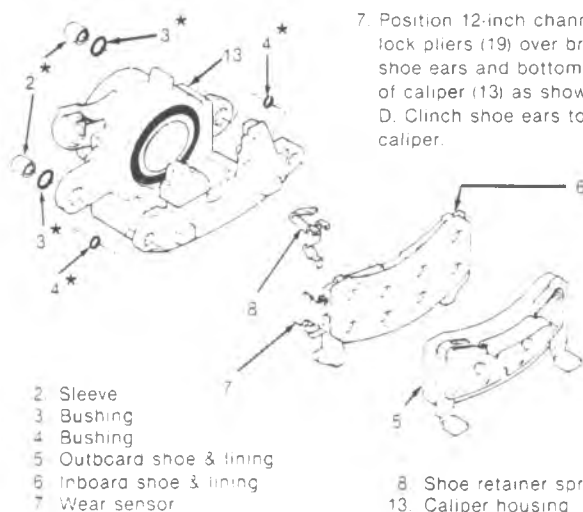

\* LUBRICATE WITH SILICONE GREASE (OR EQUIVALENT)

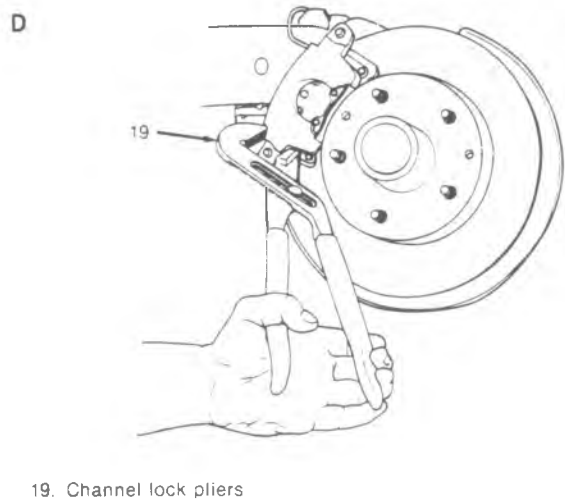
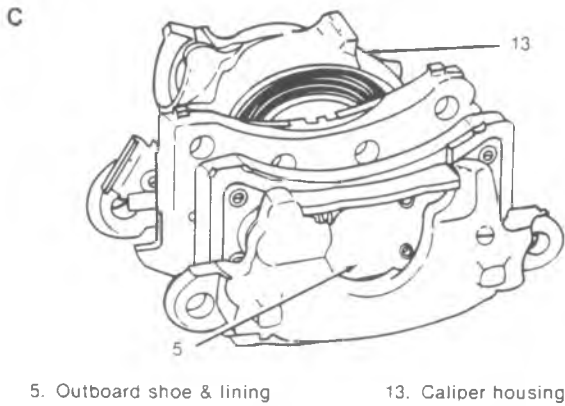
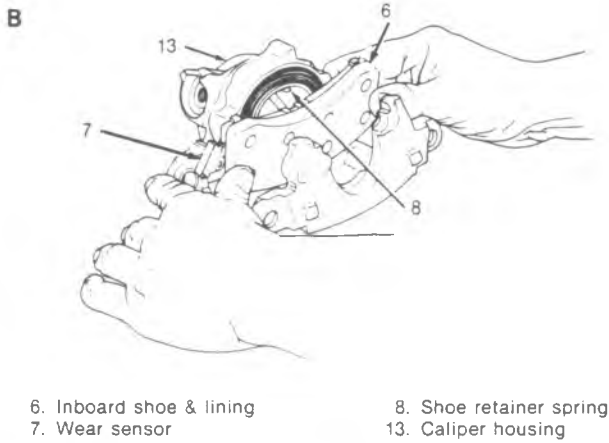
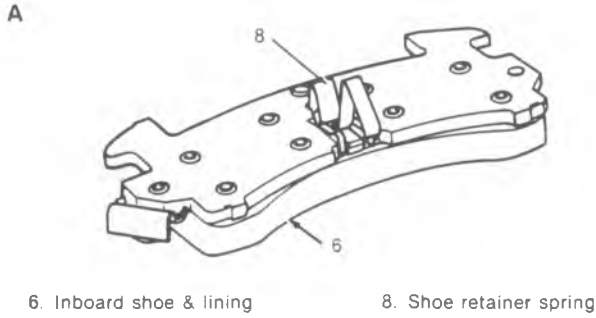

### 3. OVERHAUL CALIPER.

#### REMOVE

1. Remove piston (10) as shown in A. Use clean shop towels to pad the interior of the caliper (13) and remove the piston by directing compressed air into the caliper inlet hole.
2. Inspect piston (10) for scoring, nicks, corrosion and worn or damaged chrome plating. Replace piston if any of the above defects are found.
3. Remove boot (9) as shown in B, being careful not to scratch the housing bore.
4. Remove piston seal (11) from groove (20) in caliper bore with a piece of wood or plastic. Do not use a metal tool of any type as damage to bore may result.
5. Inspect caliper (13) bore for scoring, nicks, corrosion or wear. Use crocus cloth to polish out any light corrosion. Replace caliper housing if bore will not clean up using crocus cloth.
6. Remove bleeder valve (12).

#### INSTALL

SEE NOTICE ON PAGE 5-1 OF THIS SECTION

1. Clean all parts, not included in repair kit, in clean, denatured alcohol. Use dry, filtered compressed air to dry parts and blow out all passages in the caliper housing (13) and bleeder valve (12).
2. Install and torque bleeder valve (12) to 9-16 N-m (80-140 in-lb).
3. Lubricate new seal (11) with clean brake fluid.
4. Install piston seal (11) in caliper bore groove (20), making sure seal is not twisted.
5. Install boot (9) on piston (10) as shown in C.
6. Lubricate bore of caliper housing (13) with clean brake fluid.
7. Insert piston (10) into bore of caliper and force down to bottom in bore.
8. Position OD of boot (9) in caliper housing counterbore and seat as shown in D.
9. After installation of caliper assembly, apply approximately 778 N (175 lb) of force three times to the brake pedal.

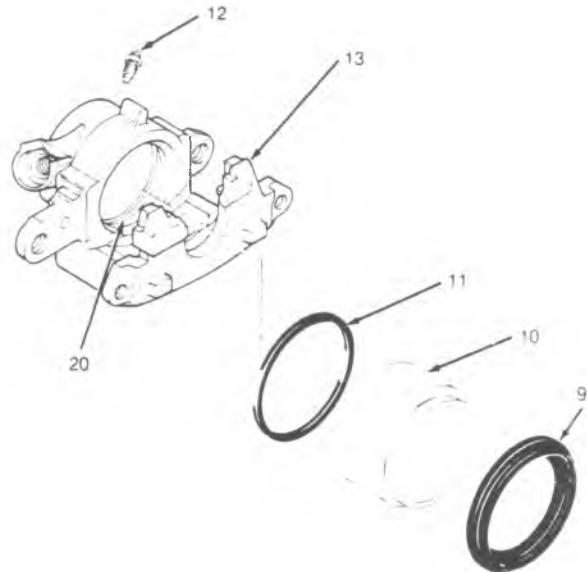

9. Boot  
10. Piston  
11. Piston seal  
12. Bleeder valve  
13. Caliper housing  
20. Seal groove

A

**CAUTION:** Do not place the fingers in front of the piston in an attempt to catch or protect it when applying compressed air. This could result in serious injury.

**NOTICE:** Use just enough air to ease the piston out of the bore. If piston is blown out—even with padding provided, it may be damaged.

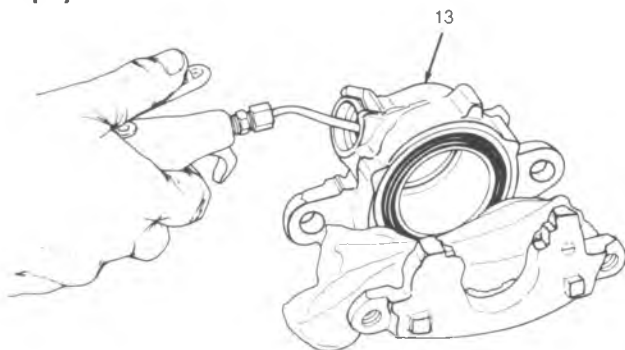

13. Caliper housing

B

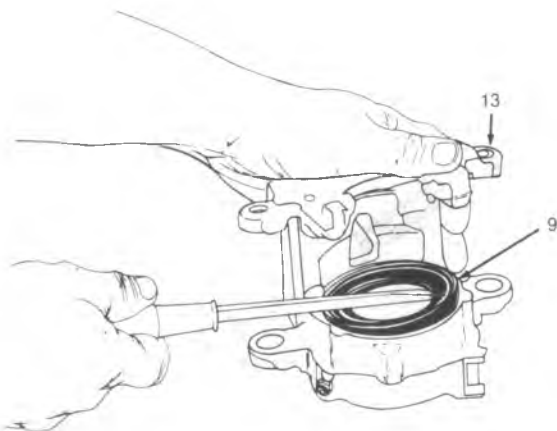

9. Boot

13. Caliper housing

C



9. Boot

10. Piston

D

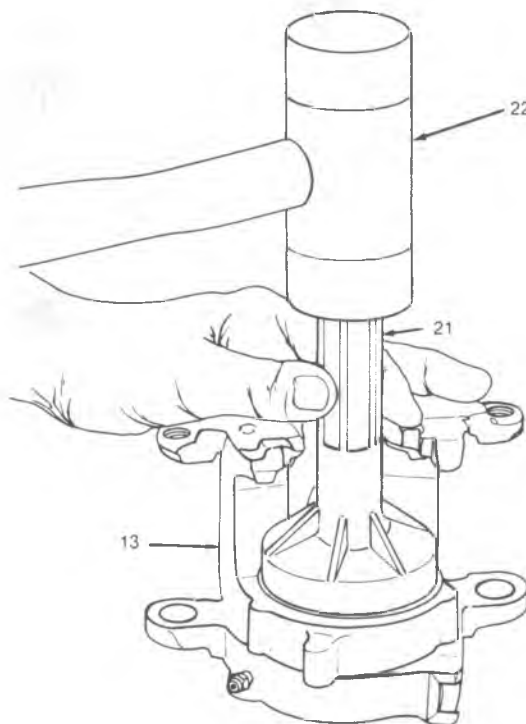

13. Caliper housing

21. Tool J-26267  
22. Plastic mallet

## COMPOSITE MASTER CYLINDER ASSEMBLY

### GENERAL DESCRIPTION

This master cylinder is designed for use with a system incorporating low drag calipers. In addition to the standard master cylinder functions, a quick take-up feature is included. This provides a large volume of fluid to the wheel brakes at low pressure with initial brake application. The low pressure fluid quickly provides the displacement requirements created by the seal retracting pistons into the front calipers and spring retraction of the rear drum brake shoes.

**NOTICE:** Replace all components included in repair kits used to service this master cylinder. Lubricate rubber parts with clean, fresh brake fluid to ease assembly. Do not use lubricated shop air on brake parts as damage to rubber components may result. If any hydraulic component is removed or brake line disconnected, bleed the brake system. The torque values specified are for dry, unlubricated fasteners.

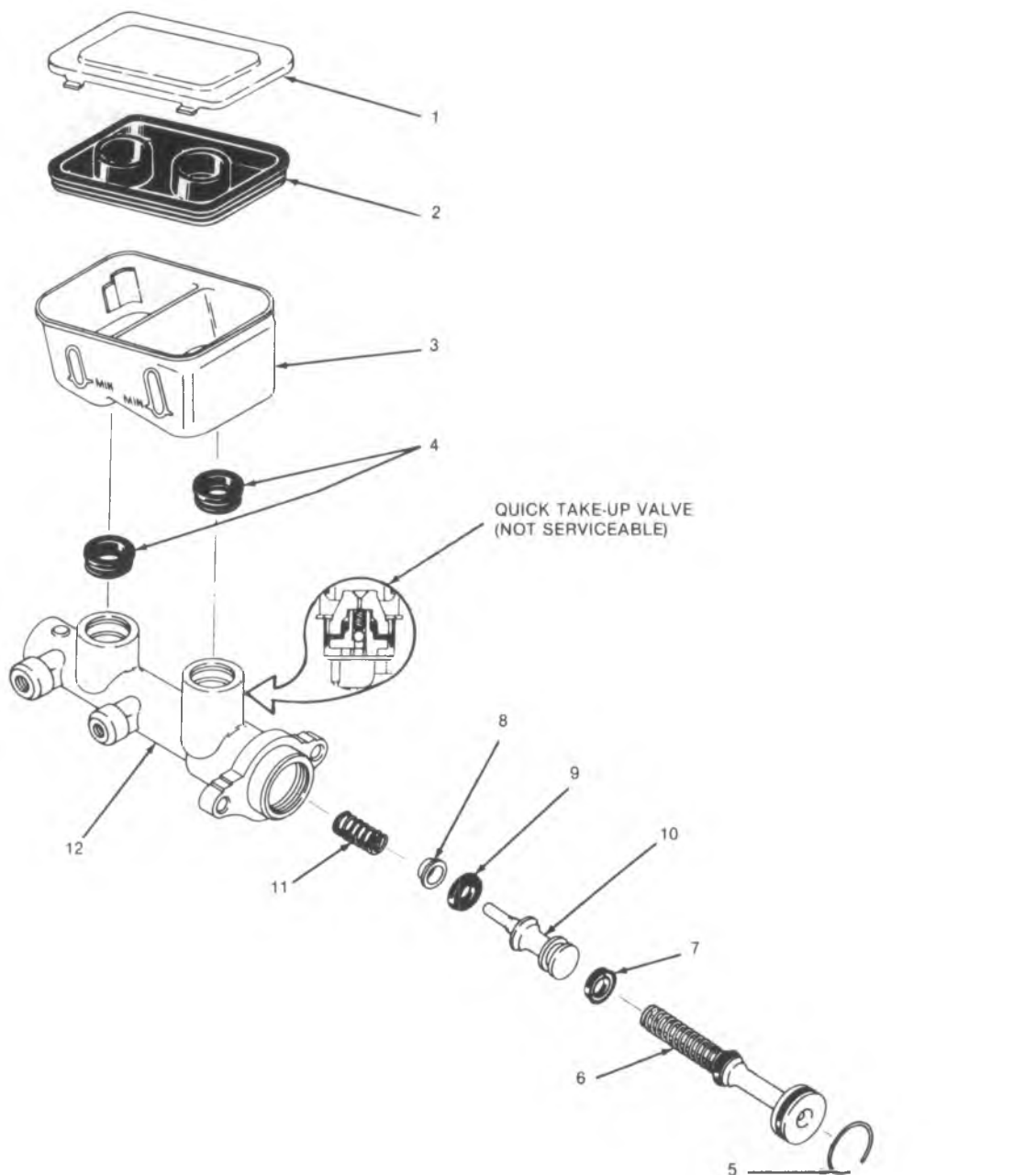

- 1. Reservoir cover
- 2. Reservoir diaphragm
- 3. Reservoir

- 4. Reservoir grommet
- 5. Lock ring
- 6. Primary piston assembly

- 7. Secondary seal
- 8. Spring retainer
- 9. Primary seal

- 10. Secondary piston
- 11. Spring
- 12. Cylinder body



### 1. REMOVE AND INSTALL MASTER CYLINDER.

#### REMOVE

1. Loosen tube nuts (14) and disconnect two hydraulic lines.
2. Remove two attaching nuts (15).
3. Remove master cylinder (13) as shown.

#### INSTALL

- SEE NOTICE ON PAGE 5-1 OF THIS SECTION
1. Install master cylinder (13) as shown and torque attaching nuts (15) to 30-45 N-m (22-30 ft-lb).
  2. Attach two hydraulic lines. Torque tube nuts (14) to 13.6-20.3 N-m (120-180 in-lb).

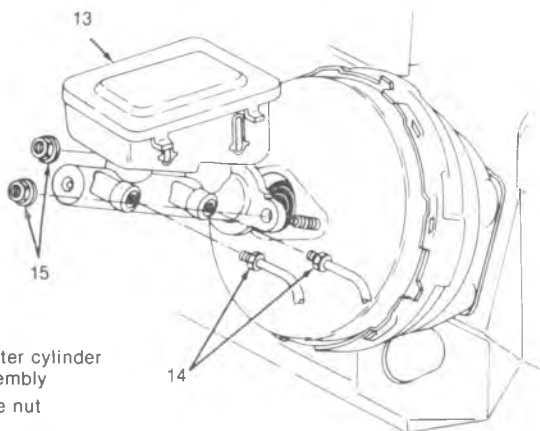

- 13. Master cylinder assembly
- 14. Tube nut
- 15. Nut

### 2. OVERHAUL MASTER CYLINDER

#### REMOVE

1. Remove reservoir cover (1) and diaphragm (2). Discard any brake fluid in reservoir.
2. Inspect reservoir cover (1) and diaphragm (2) for cuts, cracks or deformation. Replace damaged or defective parts.
3. Depress primary piston (6) and remove lock ring (5).
4. Direct compressed air into the outlet at the blind end of the bore and plug the other outlet to remove primary and secondary pistons (6 and 10).
5. Remove spring retainer (8) and seals (7 and 9) from secondary piston (10).
6. Clamp master cylinder (12) in vise as shown in A—do not clamp on master cylinder body—and use pry bar (16) to remove reservoir (3).
7. Do not attempt to remove quick take-up valve from body (12). Valve is not serviceable separately.
8. Remove reservoir grommets (4).
9. Inspect master cylinder (12) bore for corrosion. If bore is corroded, replace master cylinder. No abrasives shall be used on bore.

#### INSTALL

- SEE NOTICE ON PAGE 5-1 OF THIS SECTION
1. Lubricate new reservoir grommets (4) with silicone brake lube or brake fluid and press into master cylinder body (12). Make sure grommets are properly seated.
  2. Lay reservoir (3) on flat, hard surface as shown. Press on master cylinder body (12) using rocking motion as shown in B.
  3. Lubricate new seals (7 and 9) with clean brake fluid and install on secondary piston (10), positioning as shown. Install spring retainer (8).
  4. Install spring (11) and secondary piston assembly (7 thru 10) in cylinder (12).
  5. Lubricate primary piston (6) seals with clean brake fluid. Install primary piston, depress, and install lock ring (5).
  6. Fit diaphragm (2) in reservoir cover (1) and install on reservoir (3).

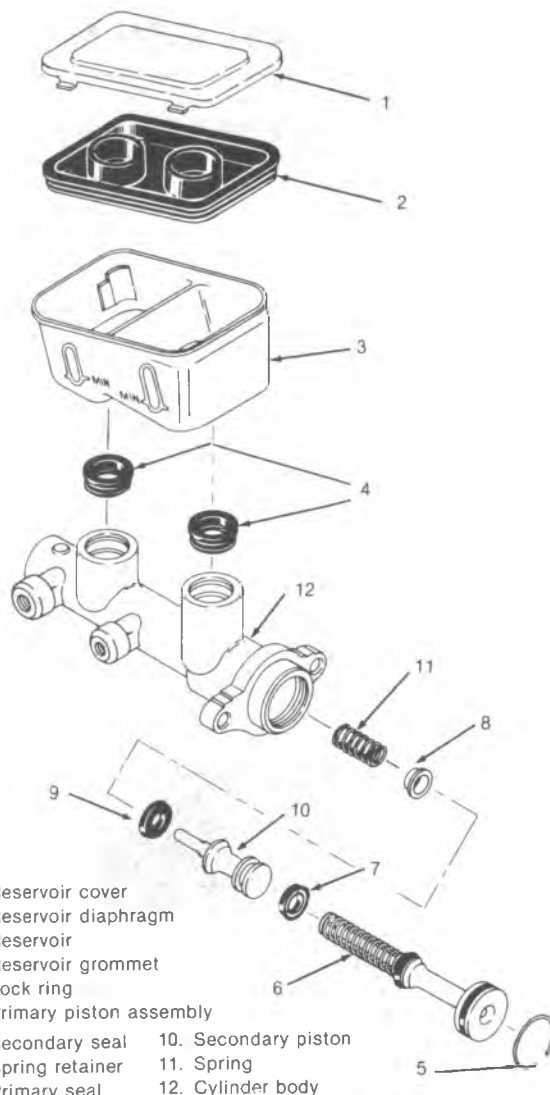

- 1. Reservoir cover
- 2. Reservoir diaphragm
- 3. Reservoir
- 4. Reservoir grommet
- 5. Lock ring
- 6. Primary piston assembly
- 7. Secondary seal
- 8. Spring retainer
- 9. Primary seal
- 10. Secondary piston
- 11. Spring
- 12. Cylinder body

A

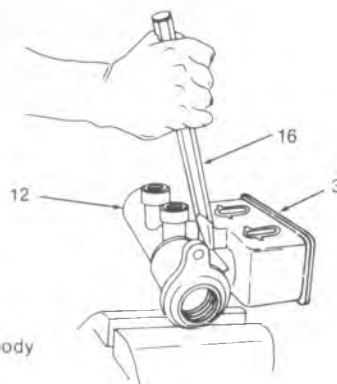

- 3. Reservoir
- 12. Cylinder body
- 16. Pry bar

B



## CAST IRON MASTER CYLINDER ASSEMBLY

### GENERAL DESCRIPTION

This master cylinder is a full cast iron design incorporating a conventional front to rear brake split. The primary piston provides the fluid pressure to the front brakes, while the secondary piston provides the fluid pressure to the rear brakes. If pressure is lost from either system, the remaining system will function to stop the vehicle in accordance with the Federal Motor Safety Standards.

**NOTICE:** Replace all components included in repair kits to service this master cylinder. Lubricate rubber parts with clean, fresh brake fluid to ease assembly. Do not use lubricated shop air on brake parts as damage to rubber components may result. If any hydraulic component is removed or brake line disconnected, bleed the brake system. The torque values specified are for dry, unlubricated fasteners.

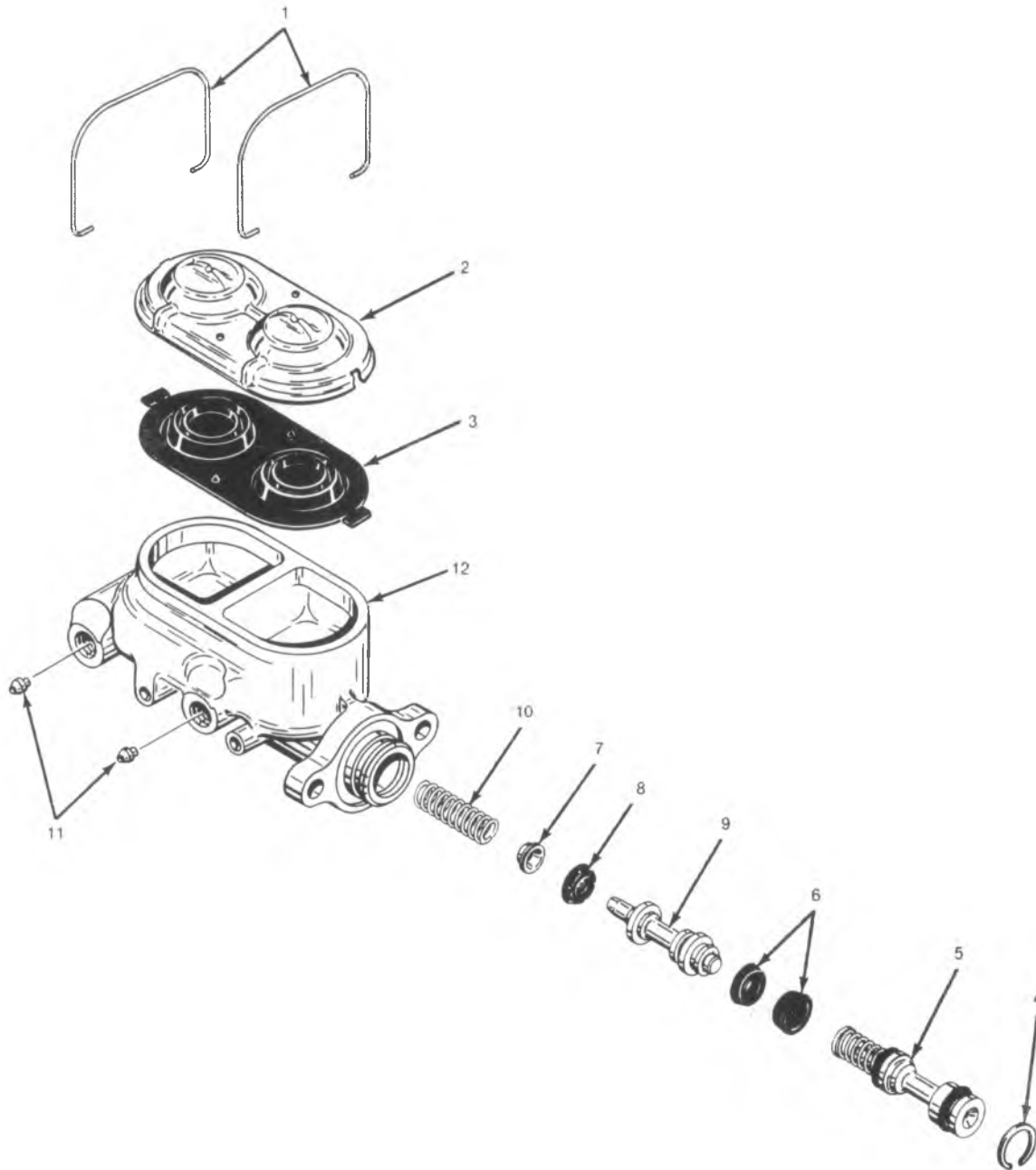

- |                        |                            |                     |
|------------------------|----------------------------|---------------------|
| 1. Bail                | 5. Primary piston assembly | 9. Secondary piston |
| 2. Reservoir cover     | 6. Secondary seal          | 10. Spring          |
| 3. Reservoir diaphragm | 7. Spring retainer         | 11. Tube seat       |
| 4. Lockring            | 8. Primary seal            | 12. Cylinder body   |

**1. REMOVE AND INSTALL MASTER CYLINDER.**

**REMOVE**

1. Loosen tube nuts (14) and disconnect two hydraulic brake pipes.
2. Remove attaching nuts (15).
3. Remove master cylinder (13).

**INSTALL**

- SEE NOTICE ON PAGE 5-1 OF THIS SECTION
1. Install master cylinder (13) as shown.
  2. Torque attaching nuts (15) to 17 N-m (150 in-lb).
  3. Attach tube nuts (14) and torque to 11 N-m (100 in-lb).

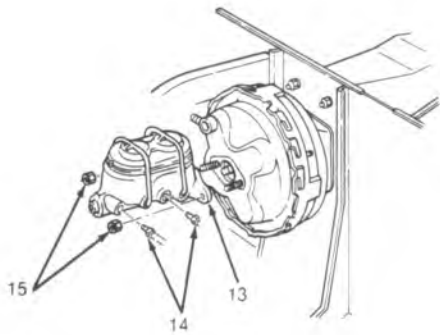

- 13. Master cylinder assembly
- 14. Tube nut
- 15. Nut

**2. REMOVE AND INSTALL RESERVOIR COVER, DIAPHRAGM AND BAILWIRES.**

**REMOVE**

1. Rotate bails (1) away from reservoir cover (2).
2. Remove reservoir cover (2) and diaphragm (3).
3. Inspect reservoir cover (2) and diaphragm (3) for cuts, cracks or deformation. Replace damaged or defective parts.
4. Remove bails (1) only if diaphragm (3) is not sealing to master cylinder body (12). Replace if defective.

**INSTALL**

- SEE NOTICE ON PAGE 5-1 OF THIS SECTION
1. Install reservoir diaphragm (3) in reservoir cover (2).
  2. Install assembly on reservoir.
  3. Secure with bails (1).

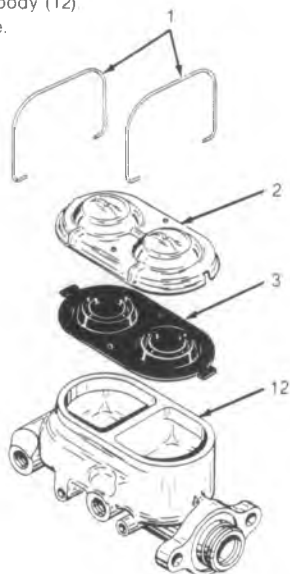

- 1. Bail
- 2. Reservoir cover
- 3. Reservoir diaphragm
- 12. Cylinder body

**3. REMOVE AND INSTALL PRIMARY AND SECONDARY PISTONS.**

**REMOVE**

1. Depress primary piston and remove locking (4).
2. Direct compressed air into the outlet at the blind end of the bore and plug the other outlet to remove primary and secondary pistons (5 and 16).
3. Disassemble secondary piston (16) as shown in A below.
4. Inspect master cylinder bore for scoring, nicks, corrosion or wear. Use crocus cloth to polish out any light corrosion. Replace master cylinder if bore will not clean up using crocus cloth.

**INSTALL**

- SEE NOTICE ON PAGE 5-1 OF THIS SECTION
1. Assemble secondary piston as shown in A.
  2. Install spring (10), spring retainer (7) and secondary piston (16) assembly in cylinder body (12).
  3. Lubricate primary piston (5) seals with clean brake fluid and install primary piston assembly. Depress primary piston and install locking (4).

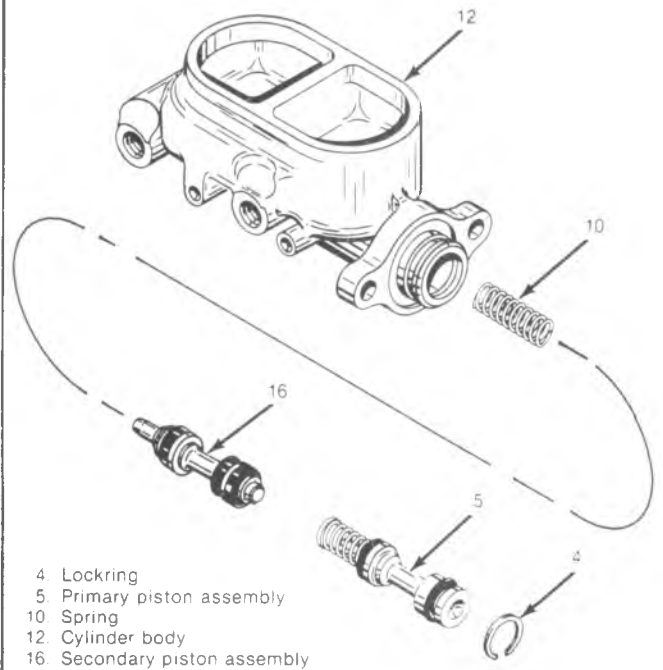

- 4. Lockring
- 5. Primary piston assembly
- 10. Spring
- 12. Cylinder body
- 16. Secondary piston assembly

**A.**

**REMOVE**

1. Remove seals (6 and 8) as shown.

**INSTALL**

1. Lubricate new seals (6 and 8) with clean brake fluid and install on secondary piston (9), positioning as shown.

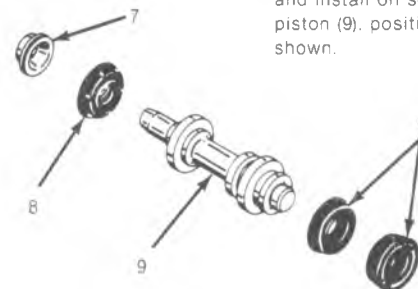

- 6. Secondary seal
- 7. Spring retainer
- 8. Primary seal
- 9. Secondary piston

#### 4. REMOVE AND INSTALL TUBE SEATS.

##### REMOVE

1. Remove tube seats (11) as shown in A below.

##### INSTALL

1. Install tube seats (11) as shown in B below.

---

##### A.

##### REMOVE

1. Thread self-tapping screw into tube seat (11) and remove as shown.

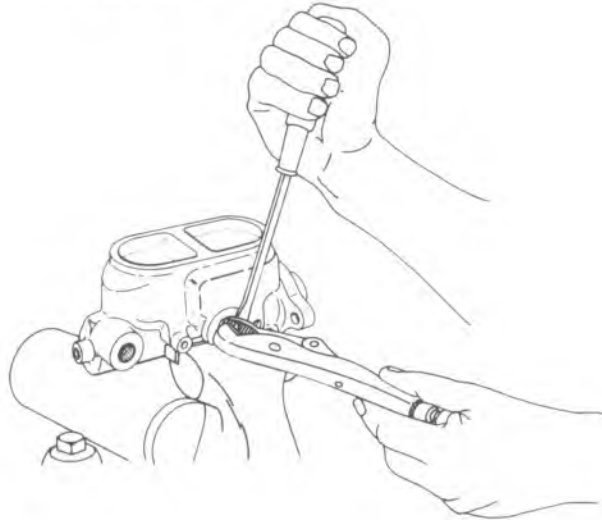

---

##### B.

##### INSTALL

1. Position tube seat (11) in body and seat with a spare brake tube nut (14).

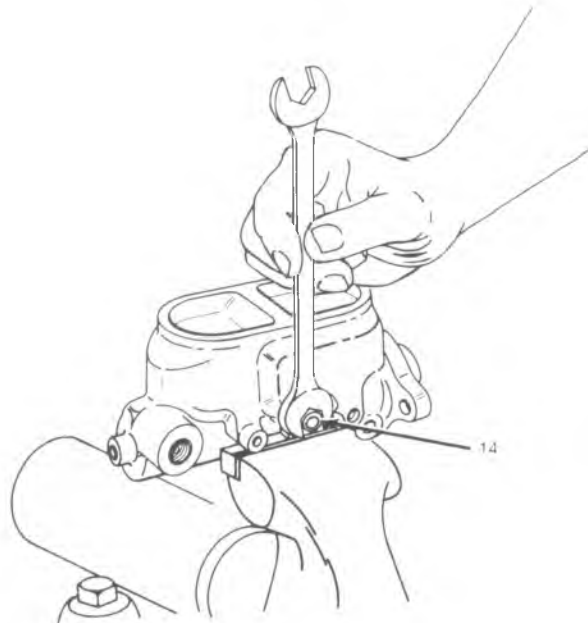

14. Tube nut

## POWER HEAD ASSEMBLY - SINGLE DIAPHRAGM

### GENERAL DESCRIPTION

This booster is a single diaphragm vacuum suspended unit. It may have a single function vacuum switch to activate the brake warning light in case of low booster vacuum or vacuum pump malfunction. In a normal operating mode, with the service brakes in the released position, a vacuum suspended booster operates with vacuum on both sides of its diaphragm. When the brakes are applied, air at atmospheric pressure is admitted to one side of the diaphragm to provide the power assist.

**NOTICE:** Use all components included in repair kits to service this booster. Lubricate rubber parts, where indicated, with silicone grease provided in kits. The torque values specified are for dry, unlubricated fasteners. If any hydraulic component is removed or brake line disconnected, bleed the brake system.

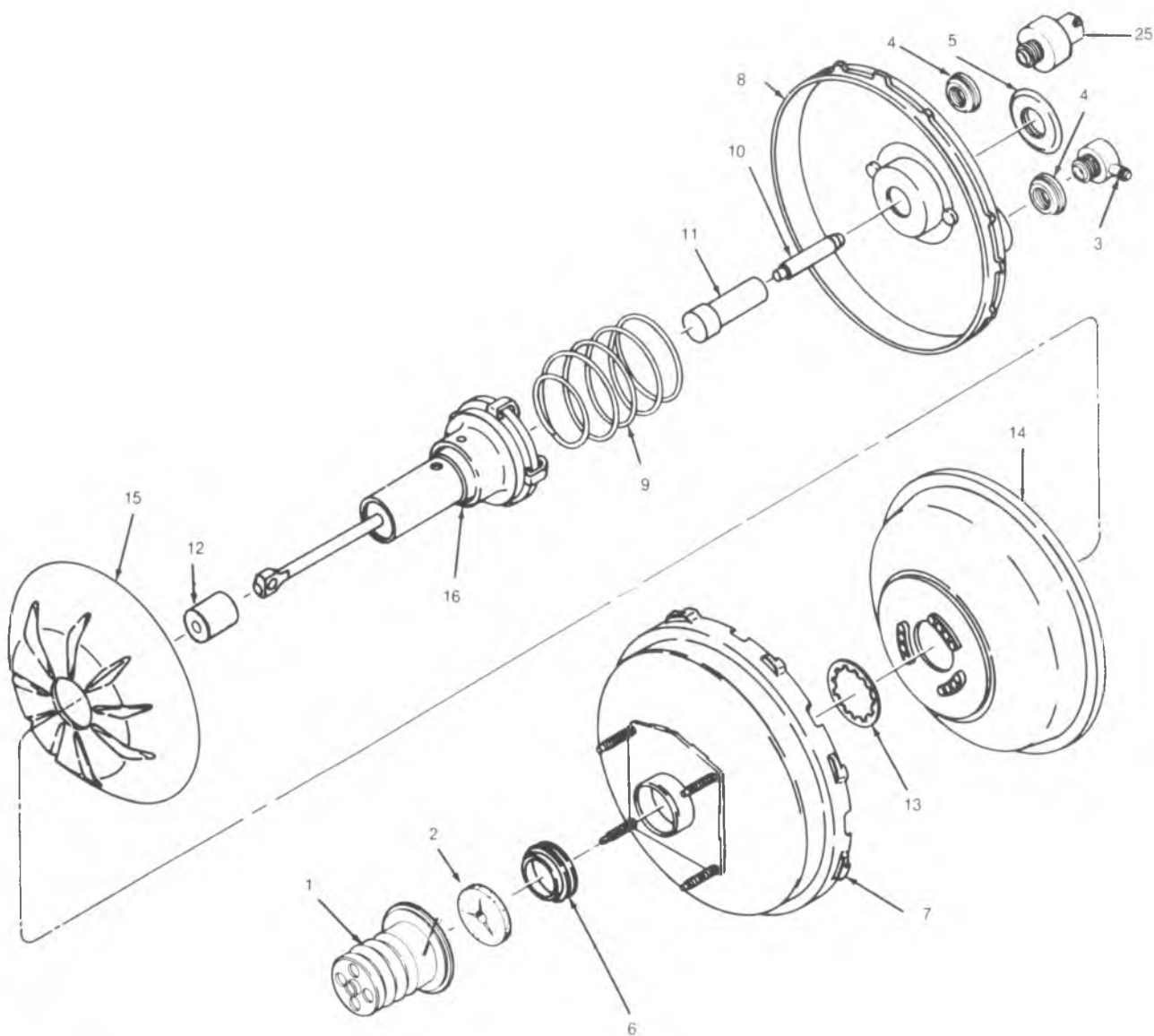

- 1. Boot
- 2. Silencer
- 3. Vacuum check valve
- 4. Grommet

- 5. Front housing seal
- 6. Power piston bearing
- 7. Rear housing
- 8. Front housing
- 9. Return spring
- 10. Piston rod (gaged)
- 11. Reaction retainer
- 12. Filter

- 13. Diaphragm retainer
- 14. Diaphragm
- 15. Diaphragm support
- 16. Power piston and pushrod assembly
- 25. Vacuum switch (some models)

**1. REMOVE AND INSTALL BOOSTER.**

**REMOVE**

1. Disconnect master cylinder (17) from booster (18) and disconnect booster pushrod (19) from brake pedal.
2. Remove attaching nuts and remove booster as shown.

**INSTALL**

SEE NOTICE ON PAGE 5-1 OF THIS SECTION.

1. Install booster to cowl as shown. Torque attaching nuts to 30-45 N-m (22-33 ft-lb).
2. Connect booster pushrod (19).
3. Install master cylinder (17) on booster (18) and torque attaching nuts (25) to 30-45 N-m (22-33 ft-lb).

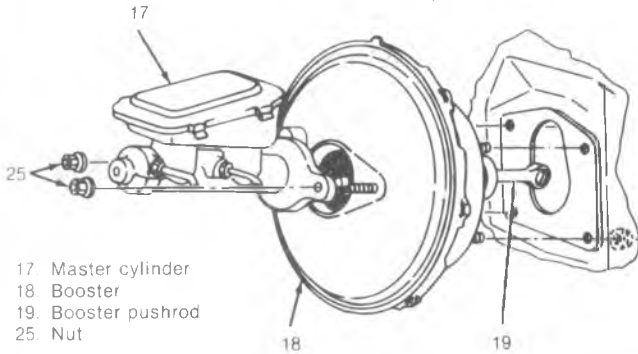

**2. REMOVE AND INSTALL EXTERIOR COMPONENTS.**

**REMOVE**

1. Remove parts as shown.

**INSTALL**

1. Lubricate inside and outside diameters of grommets (4) and front housing seal (5).
2. Install parts as shown.

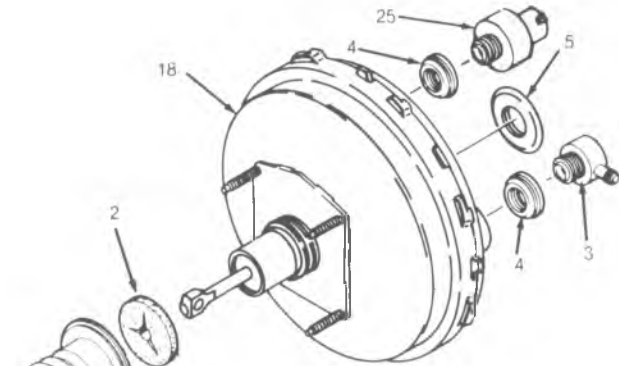

1. Boot
2. Silencer
3. Vacuum check valve
4. Grommet
5. Front housing seal
18. Booster
25. Vacuum switch (some models)

**3. UNLOCKING AND LOCKING BOOSTER.**

**DISASSEMBLY**

1. Scribe a mark on front and rear housings (7 and 8) to facilitate assembly.
2. Press down on tool J-9504 (22) and turn counterclockwise to unlock housings as shown in A.
3. Disassemble booster as shown.

**ASSEMBLE**

1. Assemble parts as shown. Make sure white coil on return spring (9) is flush against housing.
2. Align scribe marks on housings (7 and 8).
3. Press down on tool J-9504 (22) and turn clockwise to lock front and rear housings (7 and 8) as shown in A. Assembly can be facilitated by connecting a vacuum source to the booster.

4. Stake housing as shown in B after locking. Do not stake a tab that has been previously staked.

6. Power piston bearing
7. Rear housing
8. Front housing
9. Return spring
20. Power piston group

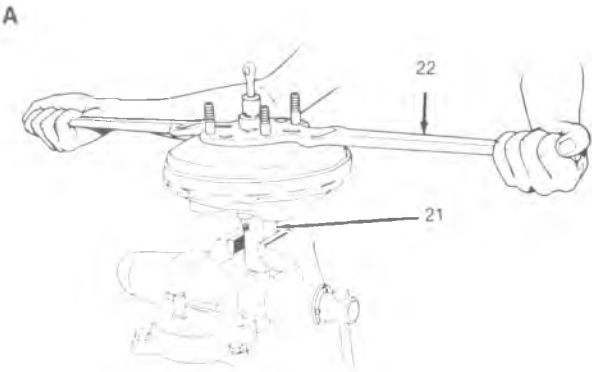
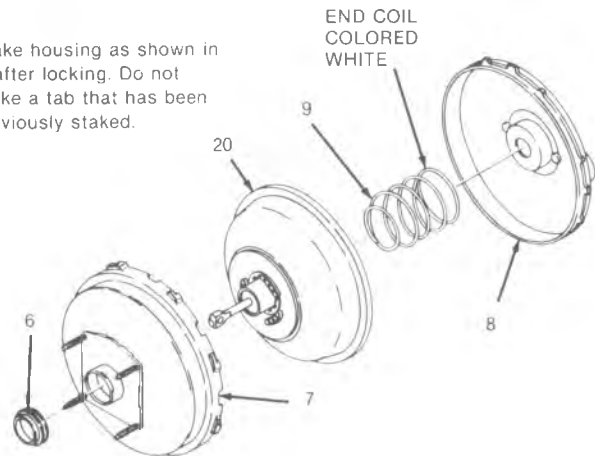

21. Fixture J-22805-01
22. Tool J-9504

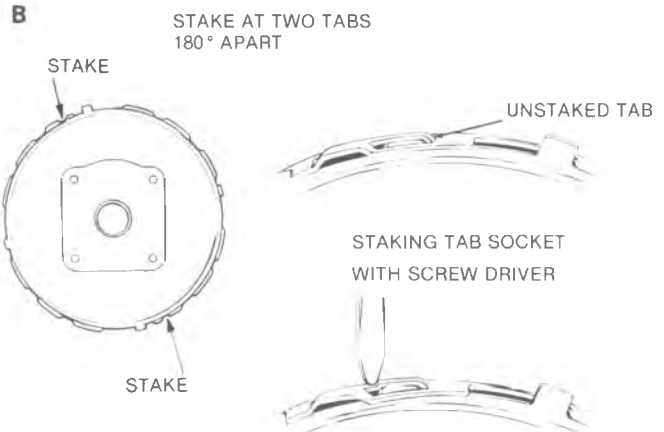

#### 4. DISASSEMBLY AND ASSEMBLY OF POWER PISTON GROUP.

##### DISASSEMBLE

1. Remove piston rod (10) and reaction retainer (11).
2. Use an awl, ice pick or similar tool to remove filter (12).
3. Grasp assembly at outside edge of diaphragm support (15) and diaphragm (14). Hold with pushrod down against a hard surface. Use a slight force or impact to dislodge diaphragm retainer (13).
4. Remove only parts shown. Do not disassemble power piston and pushrod assembly (16).

##### ASSEMBLE

1. Lubricate inside diameter of diaphragm (14) lip and fit in diaphragm support (15).
2. Install diaphragm (14) and support (15) as shown in A.
3. Install new diaphragm retainer (13) and seat as shown in B.
4. Install filter (12), reaction retainer (11) and piston rod (10).

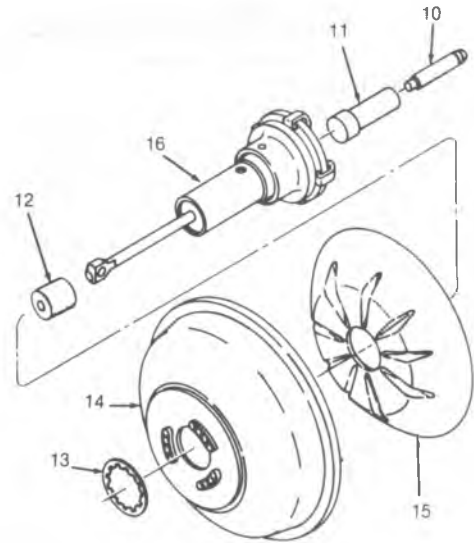

- |                        |                                       |
|------------------------|---------------------------------------|
| 10. Piston rod         | 14. Diaphragm                         |
| 11. Reaction retainer  | 15. Diaphragm support                 |
| 12. Filter             | 16. Power piston and pushrod assembly |
| 13. Diaphragm retainer |                                       |

A

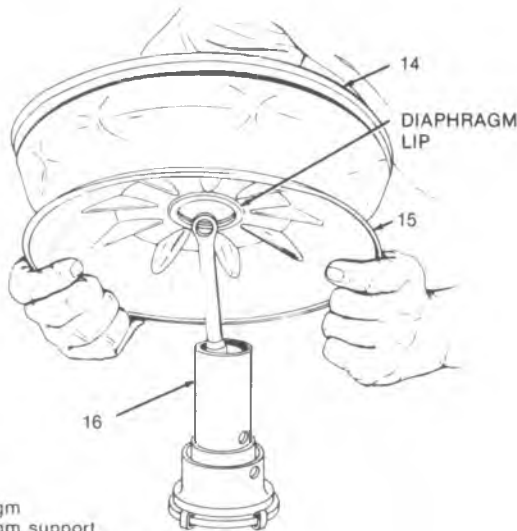

- |                                       |
|---------------------------------------|
| 14. Diaphragm                         |
| 15. Diaphragm support                 |
| 16. Power piston and pushrod assembly |

B

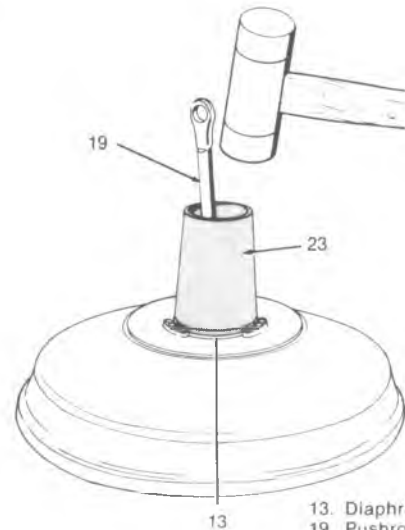

- |                        |
|------------------------|
| 13. Diaphragm retainer |
| 19. Pushrod            |
| 23. Tool J-28458       |

#### 5. GAGING PROCEDURE

##### GAGING

1. After assembly of booster, position gage (24) over piston rod (10) as shown.
2. If piston rod (10) height is not within GO-NO-GO limits of gage (24), procure and use a service-adjustable piston rod to obtain correct height.

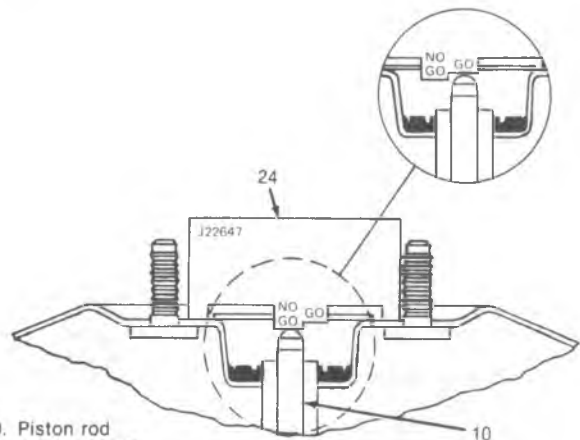

- |                  |
|------------------|
| 10. Piston rod   |
| 24. Gage J-22647 |

## POWER HEAD ASSEMBLY - TANDEM DIAPHRAGM

### GENERAL DESCRIPTION

This booster is a tandem vacuum suspended unit. It may have a single or dual function vacuum switch to activate the brake warning light in case of low booster vacuum or vacuum pump malfunction. In a normal operating mode, with the service brakes in the released position, a tandem vacuum suspended booster operates with vacuum on both sides of its diaphragms. When the brakes are applied, air at atmospheric pressure is admitted to one side of each diaphragm to provide the power assist.

**NOTICE:** Use all components included in repair kits used to service this booster. Lubricate rubber parts, where indicated, with silicone grease provided in kits. The torque values specified are for dry, unlubricated fasteners. If any hydraulic component is removed or brake line disconnected, bleed the brake system.

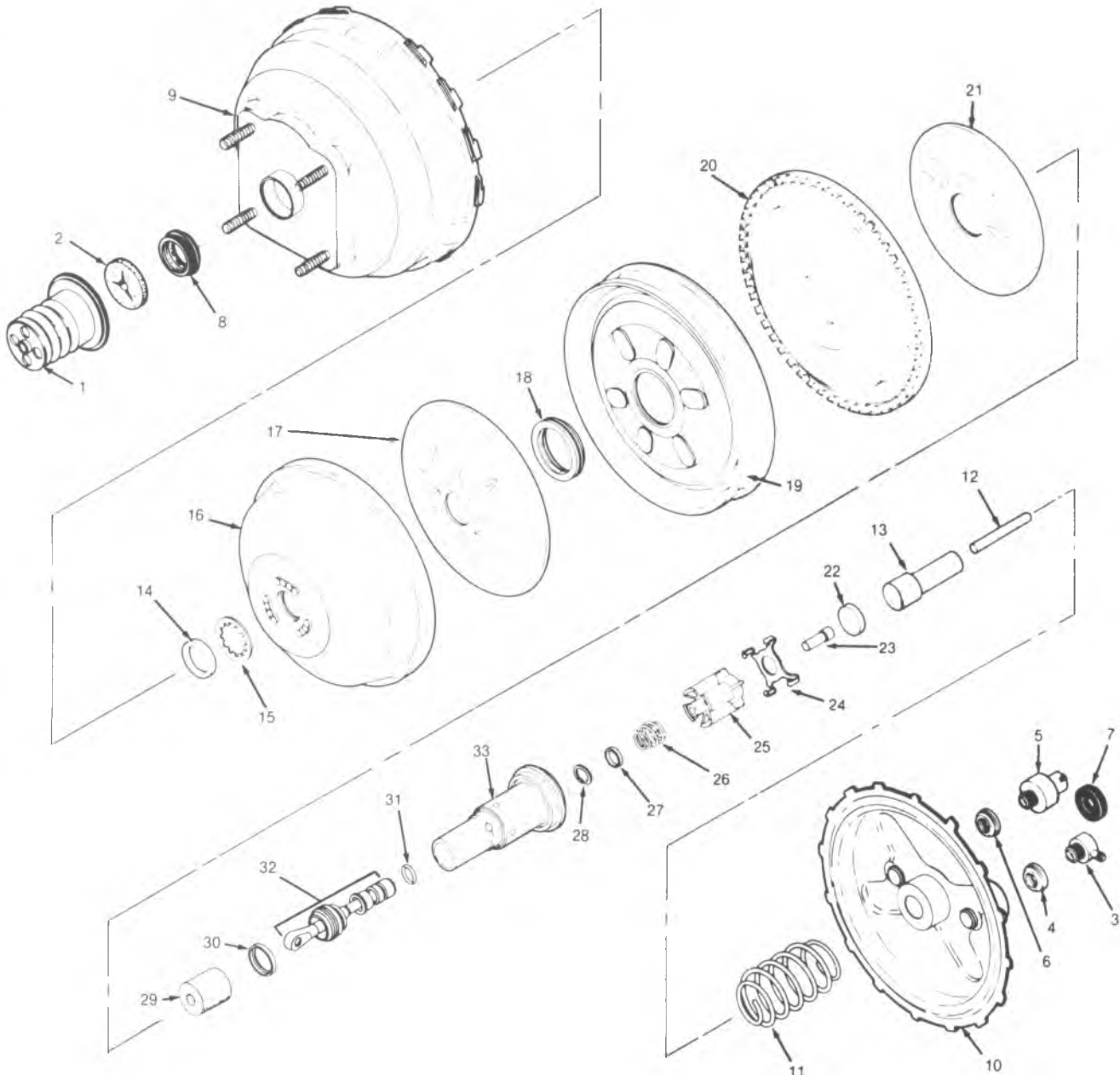

- |                                |                           |                              |                                 |
|--------------------------------|---------------------------|------------------------------|---------------------------------|
| 1. Boot                        | 10. Front housing         | 18. Secondary piston bearing | 26. Air valve spring            |
| 2. Silencer                    | 11. Return spring         | 19. Housing divider          | 27. Reaction bumper             |
| 3. Vacuum check valve          | 12. Piston rod (gaged)    | 20. Secondary diaphragm      | 28. Retaining ring              |
| 4. Grommet                     | 13. Reaction retainer     | 21. Secondary support plate  | 29. Filter                      |
| 5. Vacuum switch (some models) | 14. Power head silencer   | 22. Reaction disc            | 30. Retainer                    |
| 6. Grommet                     | 15. Diaphragm retainer    | 23. Reaction piston          | 31. O-ring                      |
| 7. Front housing seal          | 16. Primary diaphragm     | 24. Reaction body retainer   | 32. Air valve push rod assembly |
| 8. Primary piston bearing      | 17. Primary support plate | 25. Reaction body            | 33. Power piston                |
| 9. Rear housing                |                           |                              |                                 |



### 1. REMOVE AND INSTALL BOOSTER.

#### REMOVE

1. Disconnect master cylinder (34) from booster (35) and disconnect booster pushrod (32) from brake pedal.
2. Remove attaching nuts (36) and remove booster as shown.

#### INSTALL

SEE NOTICE ON PAGE 5-1 OF THIS SECTION.

1. Install booster (35) to cowl as shown. Torque attaching nuts (36) to 30-45 N-m (22-33 ft-lb).
2. Connect booster pushrod (32).
3. Install master cylinder (34) on booster (35) and torque attaching nuts (37) to 30-45 N-m (22-33 ft-lb).

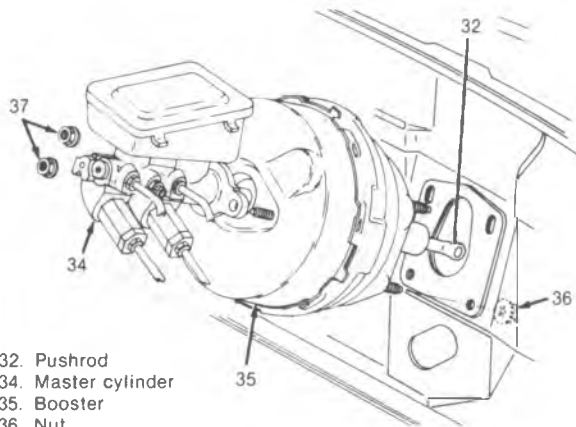

- 32. Pushrod
- 34. Master cylinder
- 35. Booster
- 36. Nut
- 37. Nut

### 2. REMOVE AND INSTALL EXTERIOR COMPONENTS.

#### REMOVE

1. Remove parts as shown.

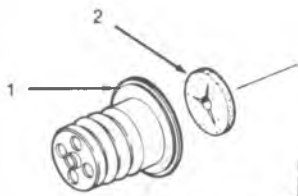

#### INSTALL

1. Lubricate inside and outside diameters of front housing seal (7) and grommets (4 and 6) for vacuum check valve (3) and vacuum switch (5). Do not lubricate vacuum switch (5) itself.
2. Install parts as shown.

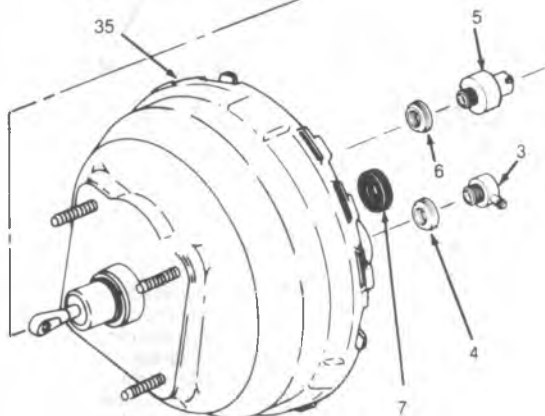

- 1. Boot
- 2. Silencer
- 3. Vacuum check valve
- 4. Grommet
- 5. Vacuum switch (some models)
- 6. Grommet
- 7. Fronhousing seal
- 35. Booster

### 3. UNLOCKING AND LOCKING BOOSTER

#### DISASSEMBLE

1. Scribe a mark on front and rear housings (9 and 10) to facilitate assembly.
2. Press down on tool J-9504 (40) and turn counterclockwise to unlock housing as shown in A.
3. Disassemble booster as shown.

#### ASSEMBLE

1. Assemble parts as shown.
2. Align scribe marks on housings (9 and 10).
3. Press down on tool J-9504 (40) and turn clockwise to lock front and rear housings (9 and 10) as shown in A. Assembly can be facilitated by connecting a vacuum source to the booster.
4. Stake housing as shown in B after locking. Do not stake a tab that has been previously staked.

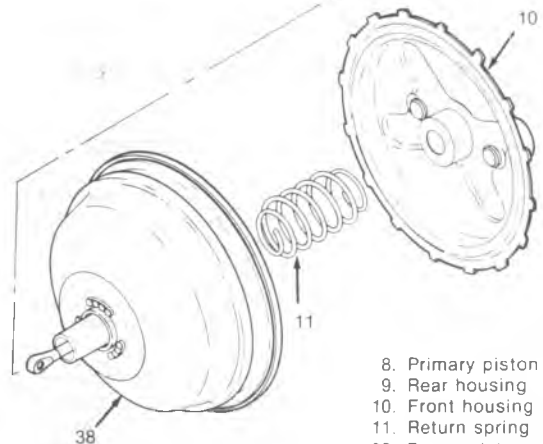
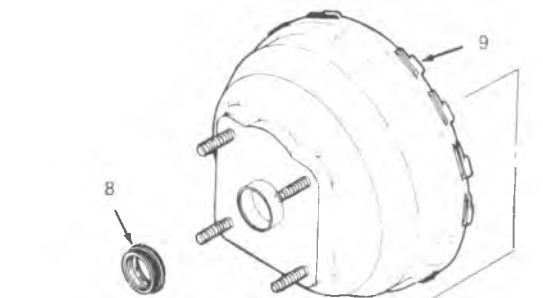

- 8. Primary piston bearing
- 9. Rear housing
- 10. Front housing
- 11. Return spring
- 38. Power piston group

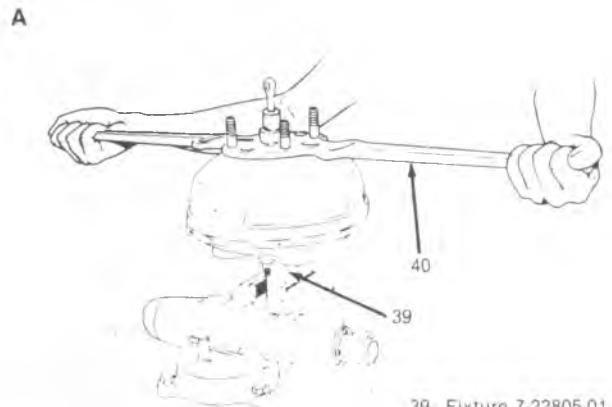

- 39. Fixture 7-22805-01
- 40. Tool J-9504

B

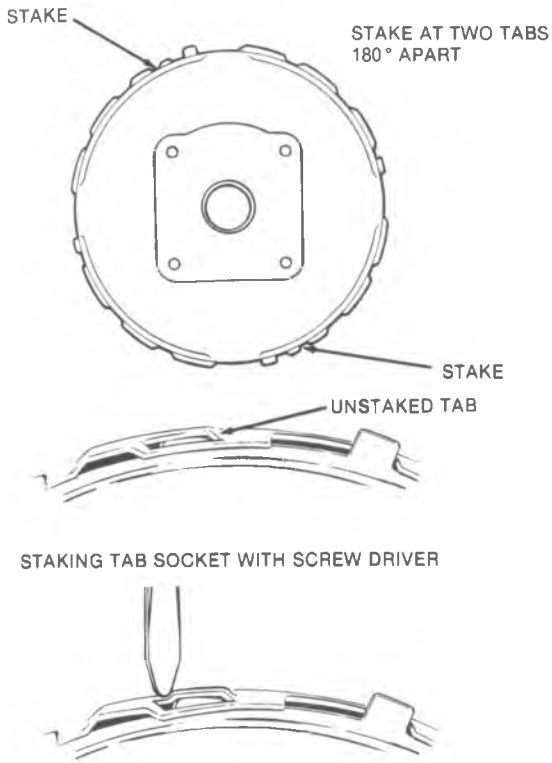

**4. DISASSEMBLY AND ASSEMBLY OF POWER PISTON GROUP.**

**DISASSEMBLE**

1. Remove piston rod (12), reaction retainer (13), and power head silencer (14).
2. Grasp assembly at outside edge of divider (19) and diaphragms (16 and 20). Hold with pushrod (32) down against a hard surface. Use a slight force or impact to dislodge diaphragm retainer (15).
3. Remove parts as shown.

**ASSEMBLE**

1. Lubricate inside diameter of secondary diaphragm (20) lip and fit in secondary support plate (21).
2. Install secondary diaphragm (20) and support plate (21) as shown in A.
3. Lubricate inside diameter of secondary piston bearing (18) and install in housing divider (19) as shown, flat surface of bearing on same side as 6 raised lugs on divider.
4. Install secondary piston bearing (18) and divider (19) as shown in B.
5. Lubricate inside diameter of primary diaphragm (16) lip and fit in primary support plate (17).
6. Install primary diaphragm (16) and support plate (17) as shown in C.
7. Install diaphragm retainer (15) and seat as shown in D.
8. Install silencer (14), reaction retainer (13) and piston rod (12).

4. (CONT)

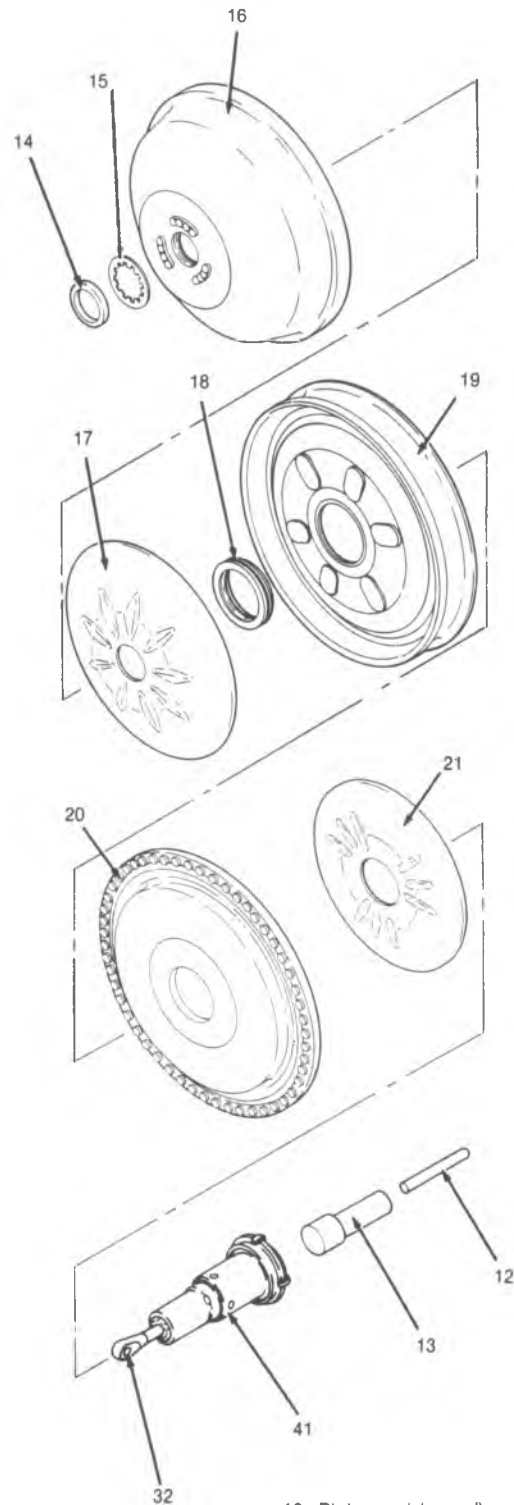

- 12. Piston rod (gaged)
- 13. Reaction retainer
- 14. Power head silencer
- 15. Diaphragm retainer
- 16. Primary diaphragm
- 17. Primary support plate
- 18. Secondary piston bearing
- 19. Housing divider
- 20. Secondary diaphragm
- 21. Secondary support plate
- 32. Pushrod
- 41. Power piston assembly

A

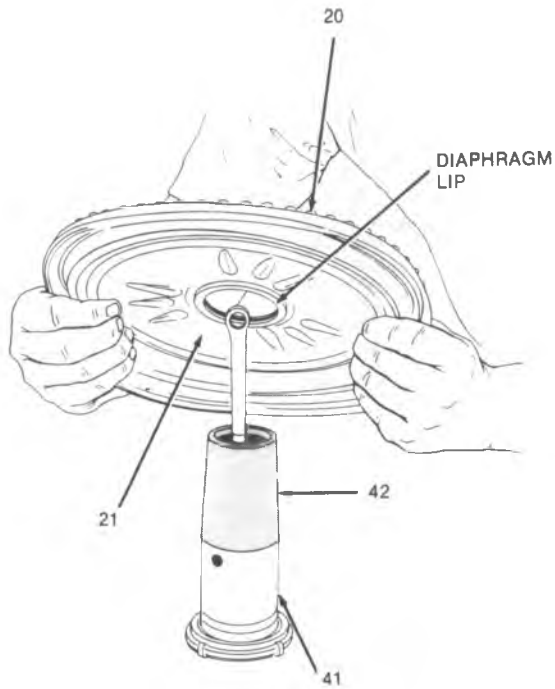

- 20. Secondary diaphragm
- 21. Secondary support plate
- 41. Power piston assembly
- 42. Tool J-28458

C

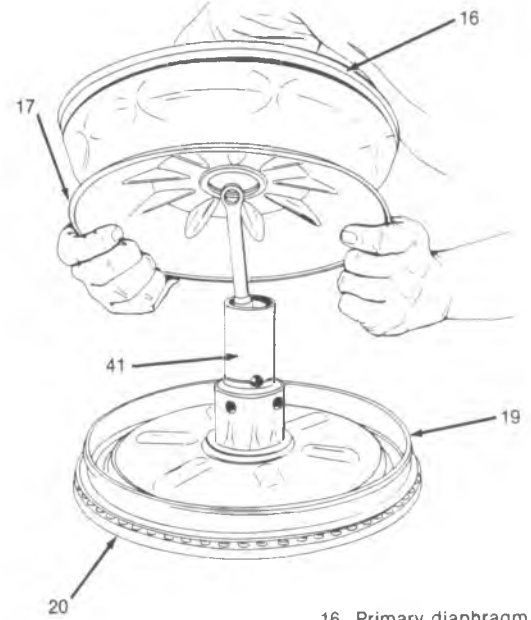

- 16. Primary diaphragm
- 17. Primary support plate
- 19. Housing divider
- 20. Secondary diaphragm
- 41. Power piston assembly

B

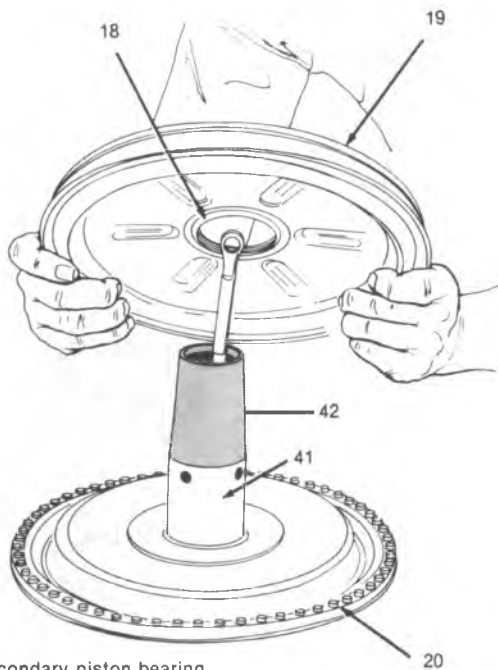

- 18. Secondary piston bearing
- 19. Housing divider
- 20. Secondary diaphragm
- 41. Power piston assembly
- 42. Tool J-28458

D

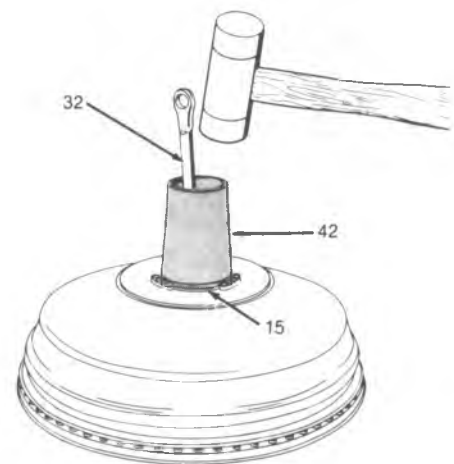

- 15. Diaphragm retainer
- 32. Pushrod
- 42. Tool J-28458

**5. DISASSEMBLE AND ASSEMBLE POWER PISTON.**

**DISASSEMBLE**

1. Disassemble as shown.
2. Pry tangs with a screwdriver to remove reaction body retainer (24).
3. Use No. 2 Truarc pliers to remove retaining ring (28) from air valve pushrod assembly (32).
4. Remove air valve pushrod assembly (32) by inserting screwdriver through eyelet and pulling straight out.

**ASSEMBLE**

1. Assemble as shown.
2. Install retainer (30) as shown in A and B.

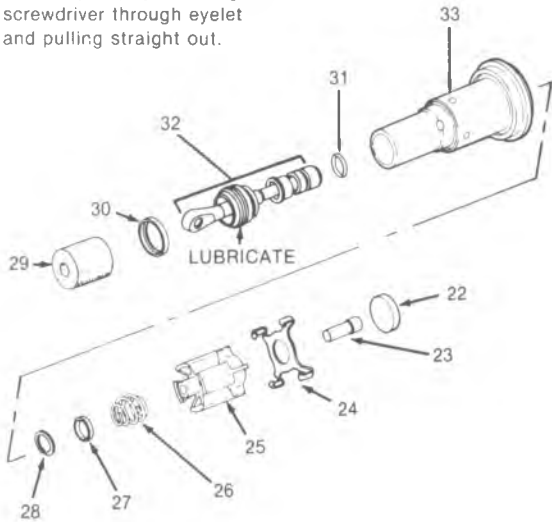

- |                            |                                 |
|----------------------------|---------------------------------|
| 22. Reaction disc          | 28. Retaining ring              |
| 23. Reaction piston        | 29. Filter                      |
| 24. Reaction body retainer | 30. Retainer                    |
| 25. Reaction body          | 31. O-ring                      |
| 26. Air valve spring       | 32. Air valve push rod assembly |
| 27. Reaction bumper        | 33. Power piston                |

**B.**

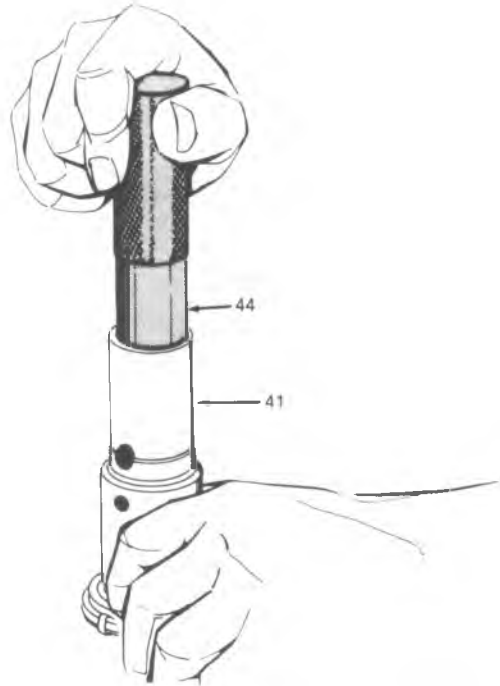

- 41. Power piston assembly
- 44. Tool J-23175-A

**A.**

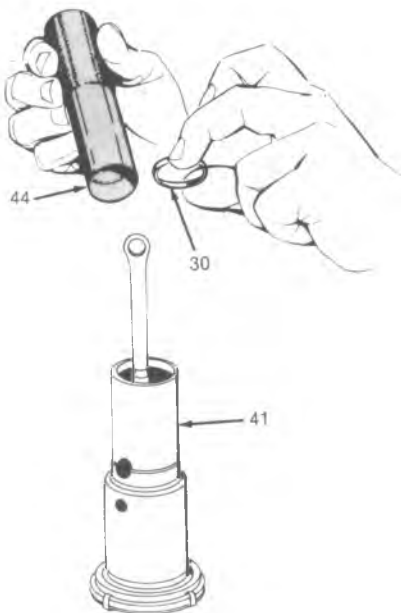

- 30. Retainer
- 41. Power piston assembly
- 44. Tool J-23175-A

**6. GAGING PROCEDURE**

1. After assembly of booster, position gage (43) over piston rod (12) as shown.
2. If piston rod height is not within GO-NO-GO limits of gage, procure and use a service-adjustable piston rod to obtain correct height.

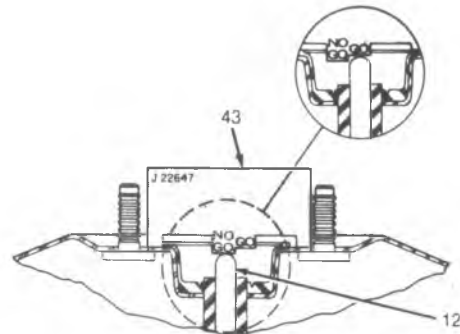

- 12. Piston rod
- 43. Gage J-22647

| Part   | Inspect For  | Corrective Action                                  |
|--|--|--|
| Power Piston and Support Plate and Reaction Retainer | 1. Cracks, distortion, chipping, damaged lever seats, pitted or rough holes.   | 1. Clean up or replace.                            |
|  | 2. Worn seal surfaces (tubes).   | 2. Replace   |
|  | 3. Rough or uneven floating valve seat.  | 3. Replace   |
|  | 4. Open passages and flow holes.   | 4. Clean   |
| Reaction Levers or Plates                            | 1. Cracks, distortion, tears and heavy wear.   | 1. Replace   |
| Floating Control Valve                               | 1. Deterioration of rubber or warped valve face.   | 1. Replace   |
| Air Valve - Push Rod Assembly                        | 1. Air valve: scratches, dents, distortion, or corrosion of I.D. or O.D. All seats to be smooth and free of nicks and dents. | 1. Do not repair - Replace.                        |
|  | 2. Push rod must move freely in air valve, but must not pull out.  | 2. If worn, replace air valve - push rod assembly. |
| Front and Rear Housings                              | 1. Scratches, scores, pits, dents, or other damage affecting rolling or sealing of diaphragm or other seals.                 | 1. Replace, unless easily repaired                 |
|  | 2. Cracks, damage at ears, damaged threads on studs.   | 2. Replace, unless easily repaired                 |
|  | 3. Bent or nicked locking lugs.  | 3. Replace, unless easily repaired                 |
|  | 4. Loose studs.  | 4. Replace or repair.                              |
| Air Filters  | 1. Dirty   | 1. Replace   |

Fig. 5-22--Inspection Chart

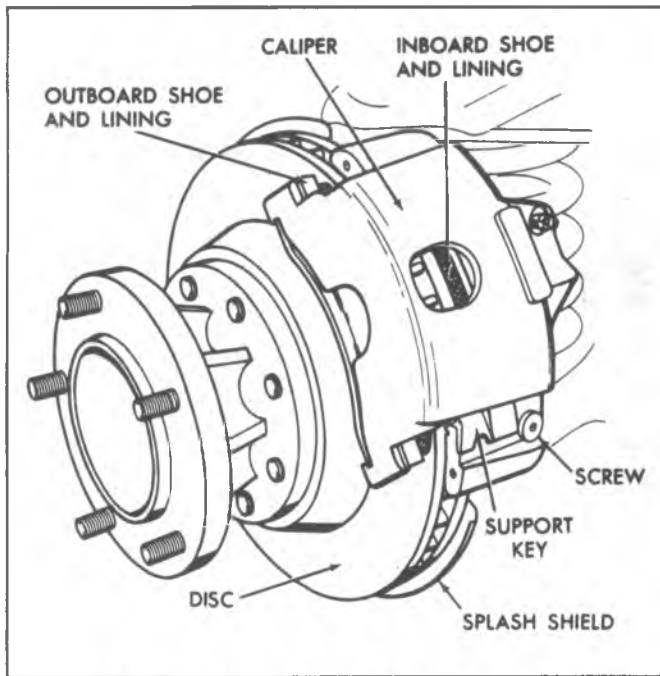

Fig. 5-23--Bendix Front Disc Brake Assembly

**BENDIX DISC BRAKE SHOE AND LINING**

The brake linings should be inspected any time the wheels are removed. Check both ends of the outboard shoe by looking in at each end of the caliper (Fig. 5-23). This is the point at which the highest rate of wear normally occurs. At the same time, check the lining thickness on the inboard shoe by looking down through the inspection hole in the top of the caliper; see "Brake Inspection" portion of this section. The inboard shoe is installed with the ends of the shoe resting in the steering knuckle. The large tab at the bottom of the outboard shoe is bent over at the right angle and fits in the cutout in the outboard section of the caliper.

**Removal (Front or Rear)**

**NOTICE:** See "Notice" on Page 1 of this section.

1. Remove master cylinder cover and observe brake fluid level in front reservoir is more than 1/3 full, siphon the

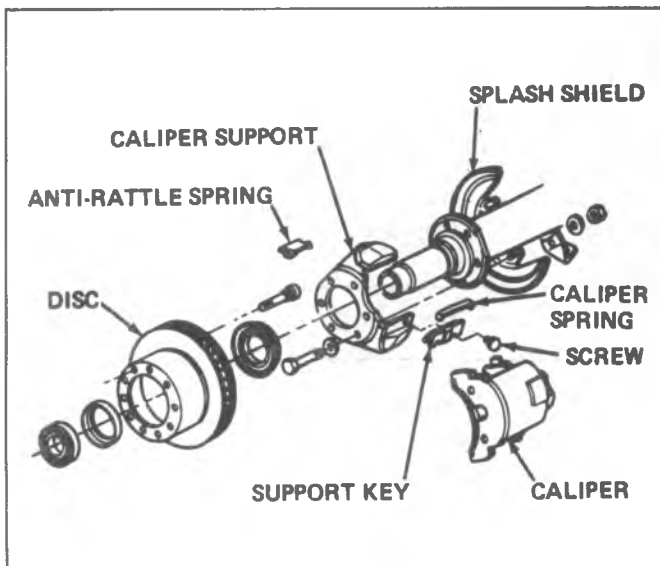

Fig. 5-24--Bendix Rear Disc Brake Assembly

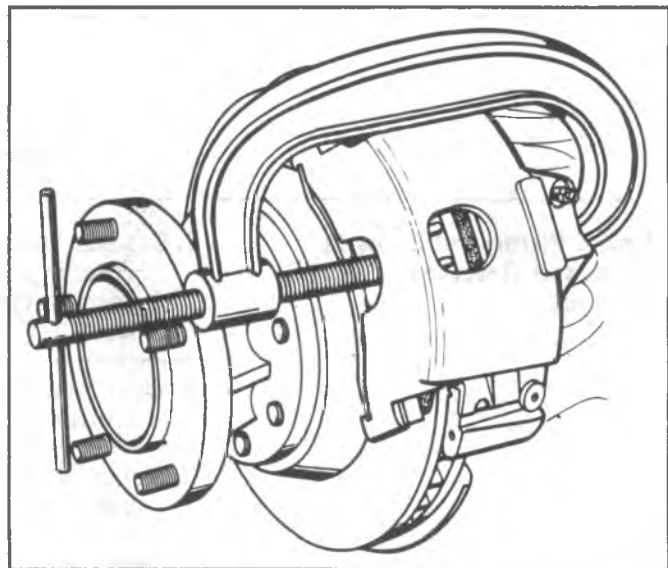

Fig. 5-25--Pushing Piston into Bore Using a "C" Clamp

necessary amount out to bring the level to 1/3 full. This step is taken to avoid reservoir overflow when the caliper piston is pushed back into its bore. Discard the brake fluid removed. Never reuse brake fluid.

2. Raise the vehicle on a hoist and remove wheels.
3. Push the piston back into its bore. This can be accomplished by using a "C" clamp as shown in Figure 5-25.
4. Remove the bolt at the caliper support key. Using a brass punch, remove the key and spring (Fig. 5-26).
5. Lift the caliper off the disc and support in a raised position with a heavy wire (Fig. 5-27).

**NOTICE:** Do not support the weight of the caliper on the brake hose as damage to the brake hose could result.

6. Remove the inboard shoe from the steering knuckle or rear caliper support (Fig. 5-24). Remove and discard the inboard shoe clip. Remove the outboard shoe from the caliper. It may be necessary to tap the shoe to loosen it in the caliper housing. Mark disc pad positions if pads are to be reinstalled.

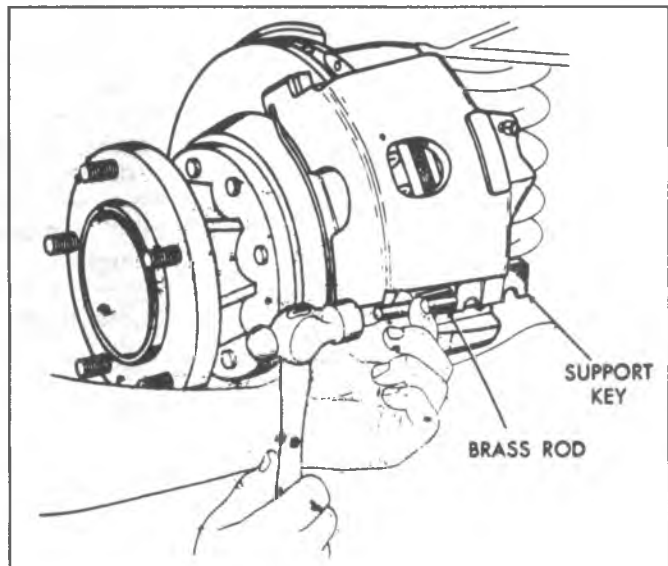

Fig. 5-26--Removing the Caliper Support Key

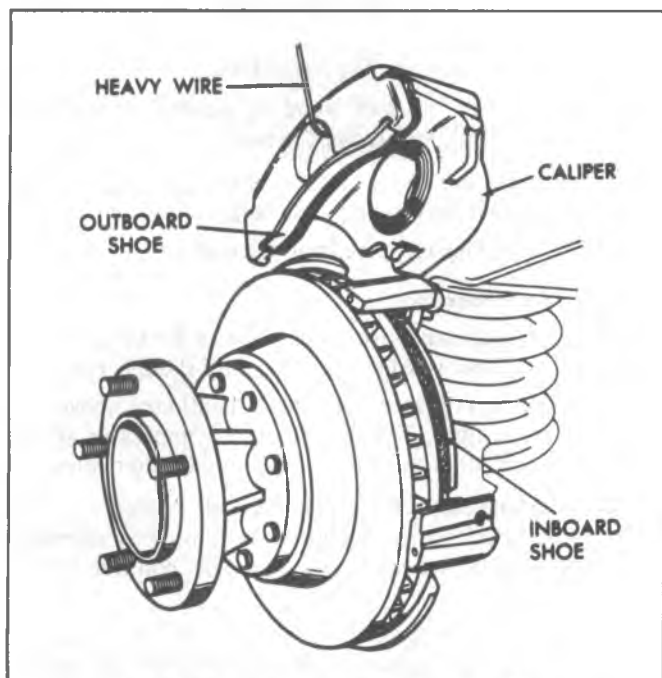

Fig. 5-27--Removing Caliper from the Disc

### Cleaning and Inspection

The shoes should be replaced when the lining is worn to approximately 1/32" (0.80 mm) thickness over the rivet heads. Replace shoes in axle sets.

1. Examine the inside of the caliper for evidence of fluid leakage. If leakage is noted, the caliper should be overhauled.
2. Wipe the inside of the caliper clean, including the exterior of the dust boot. Check the boot for cuts, cracks or other damage.

**NOTICE:** Do not use compressed air to clean the inside of the caliper since this may cause the dust boot to become unseated.

3. Use a wire brush to remove any rust or corrosion from the machined surfaces of the steering knuckle (or support) and caliper. It is important to clean those areas of the caliper and support that are in contact during the sliding action of the caliper.

### Installation

If original disc pads are being reinstalled, they must be installed in original positions (as marked at removal).

1. Lubricate the caliper and steering knuckle (or support) sliding surfaces and the support spring with Delco Silicone Lube (or equivalent).
2. Install a NEW inboard shoe clip the steering knuckle or rear support. Be sure the tabs are positioned correctly and the loop-type spring positioned away from the rotor. Install the lower end of the inboard shoe into the groove provided in the steering knuckle or support (against the spring clip). Slide the upper end of the shoe into position. Be sure the clip remains in position.
3. Position the outboard shoe in the caliper with the ears at the top of the shoe over the caliper ears and the tab at the bottom of the shoe engaged in the caliper cutout. If

assembly is difficult, a "C" clamp may be used. Be careful not to mar the lining.

4. With both shoes installed, lift up the caliper and rest the bottom edge of the outboard lining on the outer edge of the brake disc to make sure there is no clearance between the tab at the bottom of the outboard shoe and the caliper abutment. The outboard shoe should fit tightly in the caliper and should not rattle.
  5. Position the caliper over the brake disc, guiding the upper caliper groove onto the mating surface of the steering knuckle or caliper support. Position the caliper to the lower steering knuckle (or support) sliding surface.
- NOTICE:** Make sure that the brake hose is not twisted or kinked since damage to the brake hose could result.
6. Place the spring over the caliper support key, install the assembly between the steering knuckle (or rear support) and lower caliper groove. Tap into place (until the key retaining screw can be installed) using a brass punch and a light hammer (Fig. 5-28).
  7. Install the screw and torque to 12 to 18 lb. ft. (18-24 N·m). The bolt boss must fit fully into the circular cutout in the key.

**NOTICE:** See "Notice" on Page 1 of this section.

8. Reinstall the front wheel and tire assembly.
9. Add brake fluid to the master cylinder reservoir to bring the fluid level up to within 1/4" (6 mm) of the top.

**NOTICE:** Before moving the vehicle, pump the brake pedal several times to make sure that it is firm. Do not move vehicle until a firm pedal is obtained. Check master cylinder fluid level again after pumping the brake pedal.

### CALIPER OVERHAUL

#### Bendix

#### Removal

Clean dirt from hose to caliper connection before proceeding with removal.

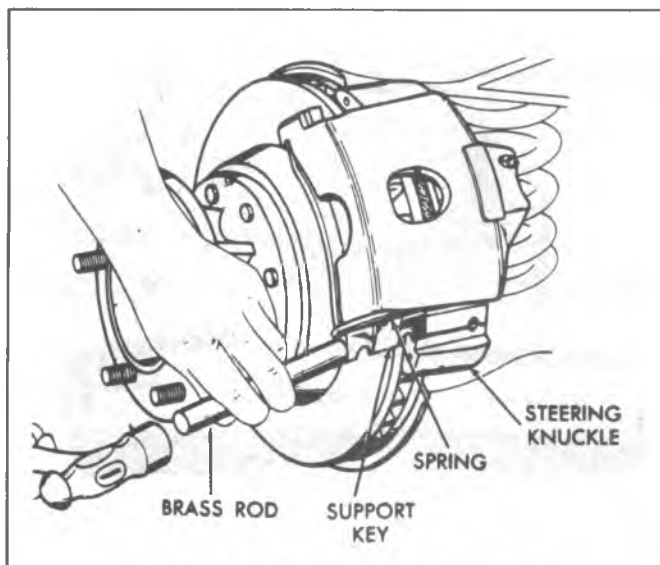

Fig. 5-28--Installing the Caliper Support Key

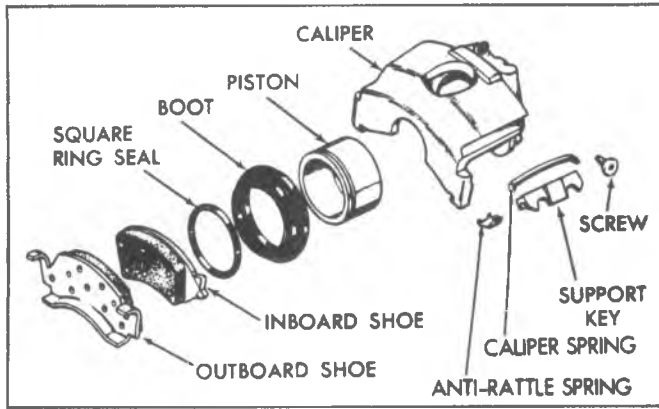

Fig. 5-29--Bendix Brake Caliper Assembly

1. Remove the hose to caliper bolt and cap or tape the open connections to prevent dirt from entering the hose or caliper. Discard the copper gaskets.
2. Remove the caliper assembly as described under "Shoe and Lining-Removal".

**Disassembly (Fig. 5-29)**

1. Clean the exterior of the caliper using clean brake fluid and place on a clean work surface.
  2. Drain the brake fluid from the caliper.
- CAUTION: Do not place the fingers in front of the piston in an attempt to catch or protect it when applying compressed air..**
3. Using clean shop cloths, pad the interior of the caliper and remove the piston by directing compressed air into the caliper inlet hole (Fig. 5-30).

**NOTICE:** Use just enough air pressure to ease the piston out of the bore. Do not blow piston out of the bore as damage to the piston could result. If the piston is seized or cocked or does not come out readily, release the air pressure and use a soft (brass) hammer to rap sharply on and around the end of the piston. Reapply air pressure to remove the piston.

**NOTICE:** An alternate method of removing the piston is to stroke the brake pedal (gently) while the hydraulic

lines are still connected. This will push the piston out of the caliper bore.

4. Remove the boot from the piston bore.
  5. Using a small piece of wood or plastic, remove the square ring seal from the piston bore.
- NOTICE:** Do not use a metal tool of any kind for this operation as it may damage the bore.
6. Remove the bleeder valve from the caliper.

**Cleaning and Inspection**

The dust boot and piston seal are to be replaced whenever the caliper is overhauled. Discard these parts.

1. Clean all parts (other than those mentioned above) in clean brake fluid. Use dry, filtered, compressor air to blow out all passages in the caliper and bleeder valve.

**NOTICE:** The use of lubricated shop air will leave a film of mineral oil on the metal parts. This may damage rubber parts when they come in contact after reassembly.

2. Check the sliding surfaces of the caliper, steering knuckle (or rear support) and support spring for rust or corrosion. Clean up any surface defects with crocus cloth.
3. Carefully examine the outside surface of the piston for scoring, nicks, corrosion and worn or damaged plating. If any surface defects are detected, replace the piston.

**NOTICE:** The piston outside diameter is the primary sealing surface in the caliper assembly. It is manufactured and plated to close tolerances. Refinishing by any means or the use of any abrasive is not acceptable practice.

4. Check the bore in the caliper for the same defects as the piston. The piston bore, however, is not plated and stains or minor corrosion can be polished with crocus cloth.

Do not use emery cloth or any other form of abrasive. Thoroughly clean the caliper after the use of crocus cloth. If the bore cannot be cleaned up in this manner, replace the caliper.

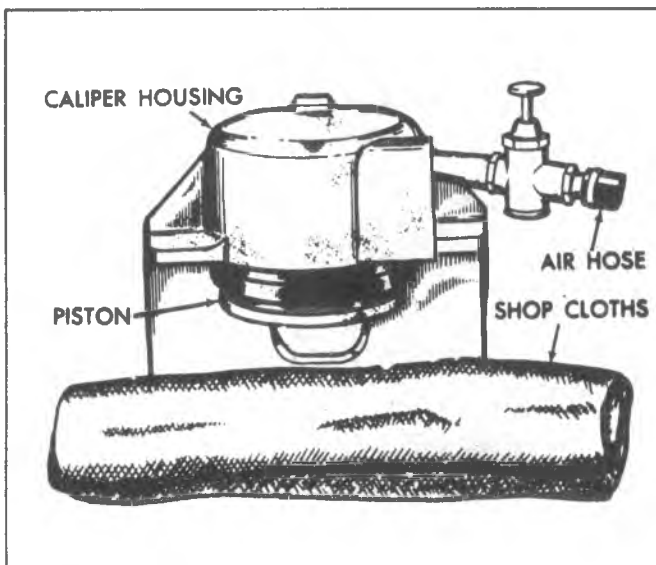

Fig. 5-30--Removing the Caliper Piston

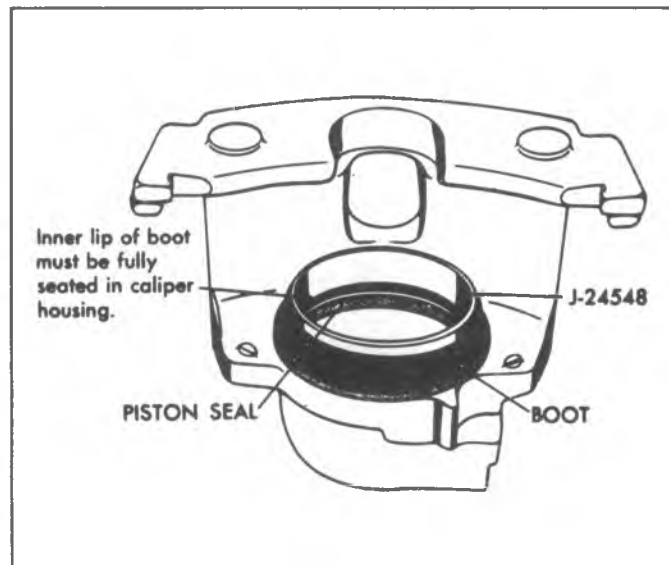

Fig. 5-31--Installing Caliper Piston Boot



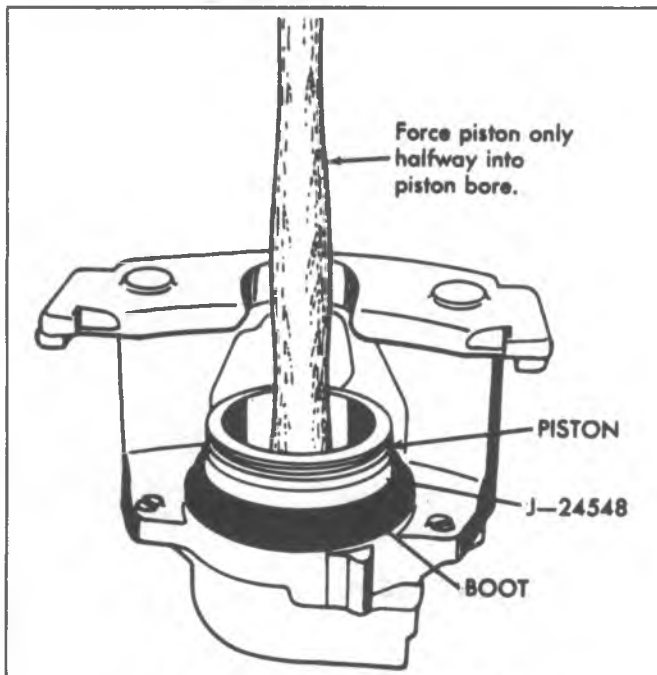

Fig. 5-32--Installing Piston in Caliper

#### Assembly

1. Lubricate the caliper piston bore and the NEW piston seal with the clean brake fluid. Position the square ring seal in the caliper bore groove.
2. Lubricate both sealing lips of the dust boot and the piston with a light film of clean brake fluid. Place the new boot over Piston Installer Tool J-24548. This is most easily accomplished by placing the boot large diameter over the tool first, then riding the smaller diameter onto the tool. The large diameter lip must then be slid off the tool to make ready for installation into the bore groove. Install the boot (large bead) into the piston bore groove by reaching inside of Tool J-24548 and pressing the boot bead into the groove (Fig. 5-31).  
Be sure boot is fully seated in the groove before proceeding.
3. Place the piston inside of Tool J-24548, force the piston halfway into the piston bore using a wood hammer handle or "C" clamp (Fig. 5-32); remove Tool J-24548. Check to be sure the boot was not unseated at piston installation. Make sure the outer bead of the boot is seated in the piston outer groove.

#### Installation

Installation of the caliper and mounting parts is the same for: "Shoe and Lining-Disc Brake" except for steps given below:

1. Connect the brake hose to the caliper using NEW copper gaskets.

**NOTICE:** Hose must be properly positioned to prevent hose, twist or misalignment or hose damage may result.

2. Bleed the caliper assemblies as outlined earlier in this section.

## Bendix Mini-Master Cylinder

#### Removal

1. Disconnect brake pipes from master cylinder and tape end of pipes to prevent entrance of dirt.
2. Manual brake only -- Disconnect brake pedal from master cylinder push rod.
3. Remove two nuts holding master cylinder to dash or power cylinder and remove master cylinder from vehicle. Be careful not to drip brake fluid on exterior paint.

#### Disassembly

1. Remove the reservoir cover and diaphragm, and drain the fluid from the reservoir.
2. Remove the four bolts that secure the body to the reservoir using Socket J-25085.
3. Remove the small "O" ring and the two compensating valve seals from the recessed areas on the bottom side of the reservoir.  
Do not remove the two small filters from the inside of the reservoir unless they are damaged and are to be replaced.
4. Depress the primary piston using a tool with a smooth rounded end. Then remove the compensating valve poppets and the compensating valve springs from the compensating valve ports in the master cylinder body.
5. Using a small screwdriver, remove the snap ring at the end of the master cylinder bore. Then release the piston and remove the primary and secondary piston assemblies from the cylinder bore. It may be necessary to plug the front outlet port to apply low air pressure to the front compensating valve port to remove the secondary piston assembly.

#### Inspection

Inspect cylinder bore for scoring or corrosion. It is best to replace a corroded cylinder. Corrosion can be identified as pits or excessive roughness.

Polish any discolored or stained area with crocus cloth by revolving cylinder on cloth supported by finger.

Rinse cylinder in clean brake fluid. Shake excess rinsing fluid from cylinder. Do not use a rag to dry cylinder, as lint from rag cannot be kept from cylinder bore surfaces.

Make certain that compensating port in cylinder is clear.

If scratches or corroded spots are too deep to be polished satisfactorily, the cylinder should be replaced.

#### Assembly

1. Lubricate the secondary piston assembly and the master cylinder bore with clean brake fluid.
2. Assemble the secondary spring (shorter of the two springs) in the open end of the secondary piston actuator, and assemble the piston return spring (longer spring) on the projection at the rear of the secondary piston.
3. Insert the secondary piston assembly, actuator end first, into the master cylinder press assembly to the bottom of the bore.
4. Lubricate the primary piston assembly with clean

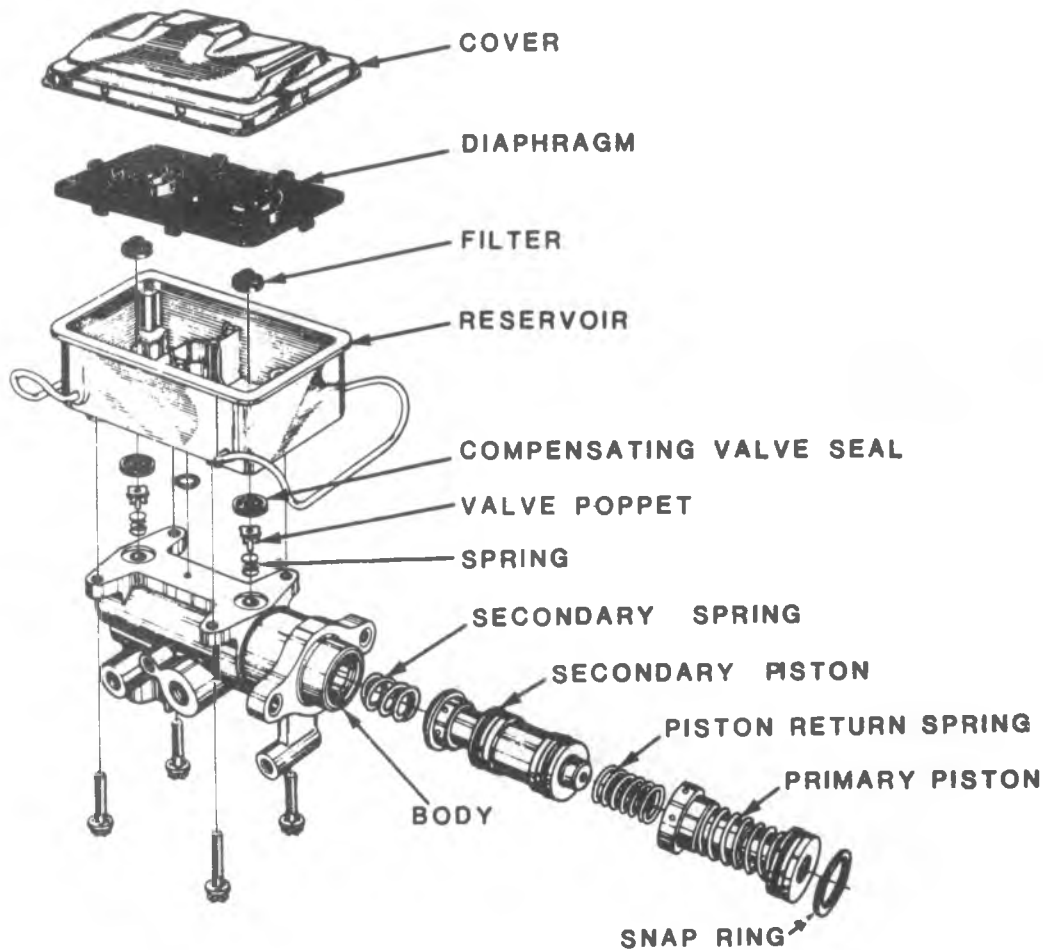

Fig. 5-33--Bendix Mini-Master Cylinder-Exploded View

brake fluid. Insert the primary piston assembly, actuator end first, into the bore.

5. Place the snap ring over a smooth round ended tool and depress the pistons in the bore.
6. Assemble the retaining ring in the groove in the cylinder bore.
7. Assemble the compensating valve seals and the small "O" ring seal in the recesses on the bottom of the reservoir. Be sure that all seals are fully seated.
8. While holding the pistons depressed, assemble the compensating valve springs and the compensating valve poppets in the compensating valve ports.
9. Holding the pistons compressed, position the reservoir on the master cylinder body and secure with the four mounting bolts. Tighten the bolts to 12-15 lb. ft. (16-20 N·m).

#### Installation

**NOTICE:** Refer to "Notice" on Page 1 of this section regarding fasteners referred to in Steps 1 and 2 below.

1. Manual brake only -- Connect push rod to brake pedal pin and install retainer while holding master cylinder in place.
2. Install master cylinder on dash or power cylinder; torque nuts to specifications.
3. Connect brake pipes to master cylinder.
4. Bleed hydraulic system.
5. Road test vehicle for proper brake performance.

#### BENDIX HYDRAULIC BRAKE BOOSTER (HYDRO-BOOST)

**CAUTION:** The accumulator contains compressed gas. Always use proper tools and follow recommended procedures or personal injury may result. Do not apply heat to accumulator. Do not attempt to repair an inoperative accumulator, always replace with a new accumulator. Dispose of an inoperative accumulator by drilling a 1/15" diameter hole through the end of the accumulator

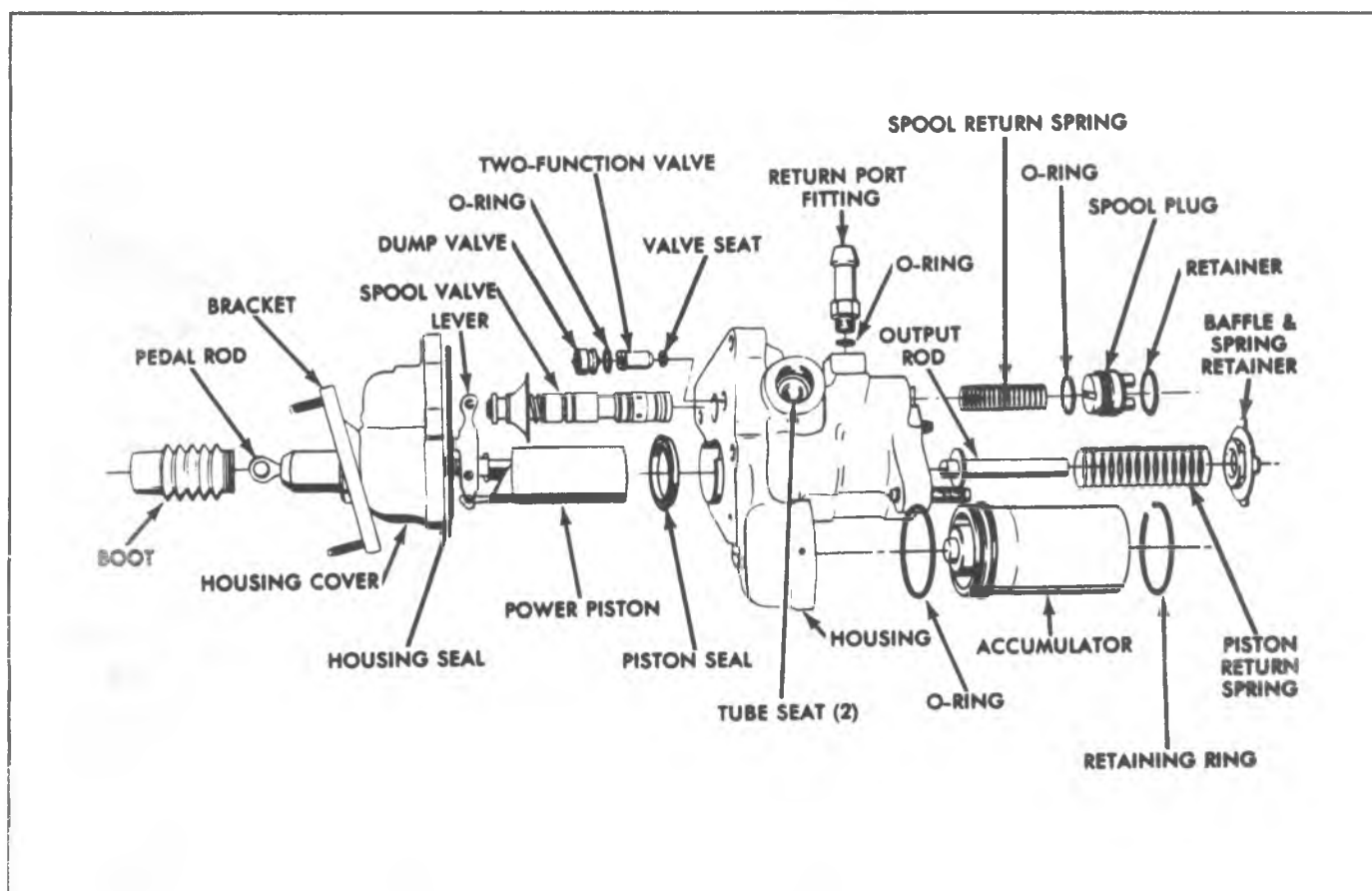

Fig. 5-B1--Bendix Hydro-Boost Explode-Typical

can opposite the "O" ring.

The Bendix Hydraulic Brake Booster utilizes the hydraulic pressure supplied by the power steering pump to provide power assist for brake applications. The dual master cylinder is mounted to the output push rod end of the booster.

The procedures below include removal of the mounting bracket even though it is not necessary to remove the bracket for overhaul of the internal assembly.

#### Disassembly (Fig. 5-B1)

1. Secure the booster in a vise (bracket end up) and use a hammer and chisel to cut the bracket nut that secures the mounting bracket to the power section (cut the nut at the open slot in the threaded portion of the housing). Be careful to avoid damage to the threads on the booster hub. Spread the nut and remove it from the power section. Then remove the mounting bracket.
2. Remove the pedal rod boot (if equipped) by pulling it off over the pedal rod eyelet.
3. Place Tool J-24569 around the pedal rod and resting on the input rod end as shown as in Figure 5-B2.
4. Place a punch (or similar tool) through the pedal rod from the lower side of Tool J-24569. Push the punch on through to rest on the higher side of the tool. Lift up on the punch to shear the pedal rod retainer; remove the pedal rod.
5. Remove the remnants of the rubber grommet from the groove near the end of the pedal rod and from the groove inside the input rod end.

6. With a small screwdriver, pry the plastic guide out of the output push rod retainer. Disengage the tabs of the spring retainer from the ledge inside the opening near the master cylinder mounting flange of the booster. Remove the retainer, the piston return spring and output rod from the opening (Fig. 5-B3).
7. Place the booster cover in a vise equipped with soft jawed devices. Remove the five screws that secure the booster housing to the cover.
8. Remove the booster assembly from the vise and while holding the unit over a pan, separate the cover from the housing. Remove the "figure eight" seal from the housing cover; discard the seal.
9. Remove the input rod and piston assembly, the spool assembly and spool spring from the booster housing. Compare spool valve condition to Figure 5-B4. If spool valve is defective, the complete unit must be replaced.
10. Inspect power piston. If scratches big enough to be felt with a fingernail are present, the input rod and piston must be replaced.
11. Remove the input rod seals from the input rod end, and the piston seal from the piston bore in the housing; discard the seals.
12. Place the accumulator retaining cap Tool J-26889 over the master cylinder stud and install the nut as shown in Figure 5-B6.
13. Using Tool J-22269-01 or a large "C" clamp (6" minimum), depress the accumulator. Insert a punch into the hole in the housing and remove retaining ring with a small screwdriver, (Fig. 5-B6).

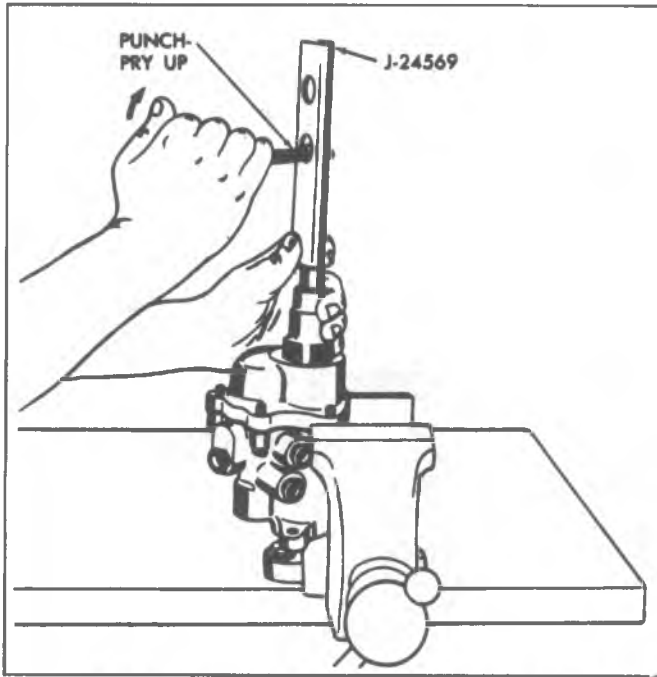

Fig. 5-B2--Removing Booster Pedal Rod (Typical)

14. Slowly back off the clamp until tension on the accumulator is released; remove accumulator and "O" ring.
15. If accumulator valve was determined to be faulty, remove valve using a small diameter wire tool (Fig. 5-B5). Remove the dump valve by catching the tool under the pin guide near the center of the valve, then remove two function valves and seat (Fig. 5-B8).
16. Return hose fitting "O" ring can be removed if leaking.
17. Push spool valve plug in and use a small screwdriver to remove retaining ring (Fig. 5-B9).
18. Remove spool valve plug and "O" ring.
19. Remove the tube seats using No. 4 easy-out as shown in Figure 5-B10.

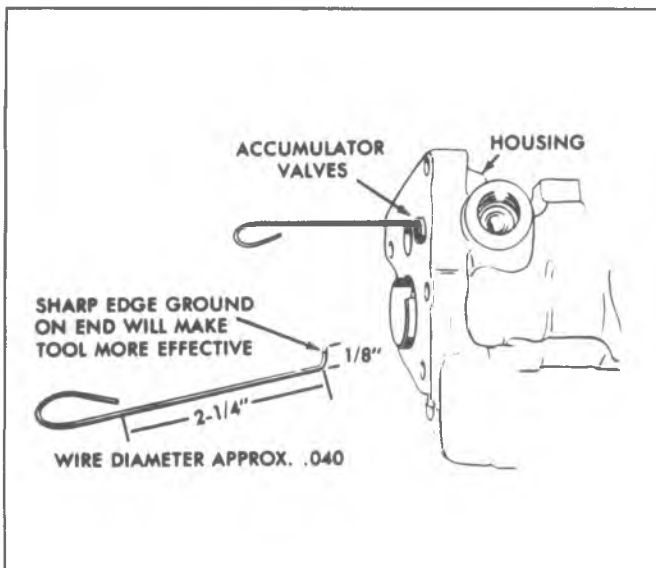

Fig. 5-B5--Removing Accumulator Valves

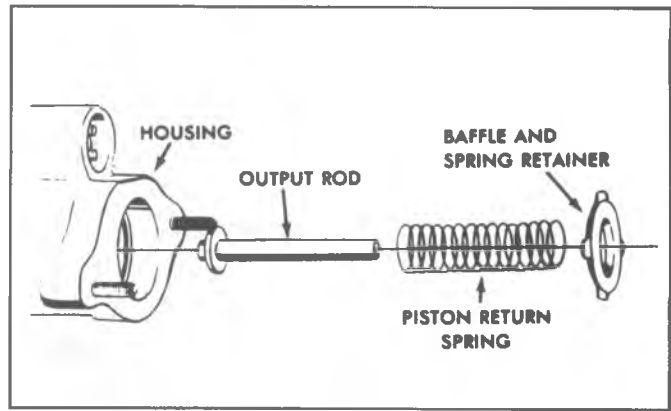

Fig. 5-B3--Output Rod, Spring and Retainer

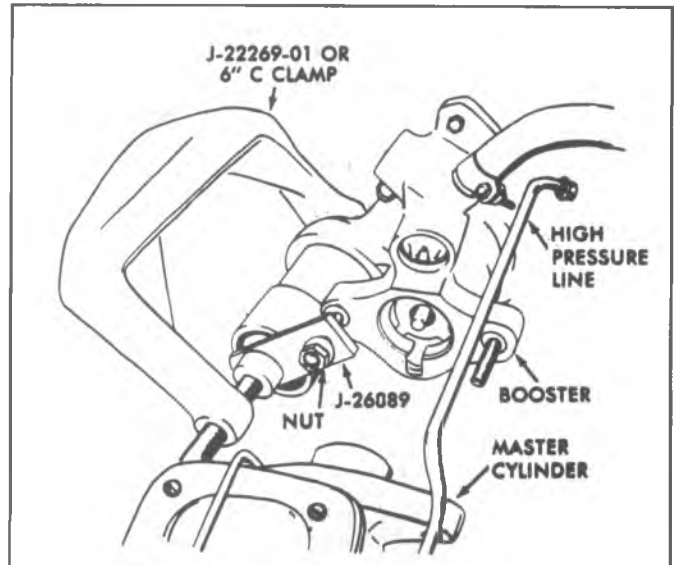

Fig. 5-B6--Compressing Accumulator With J-26889

### Cleaning and Inspection

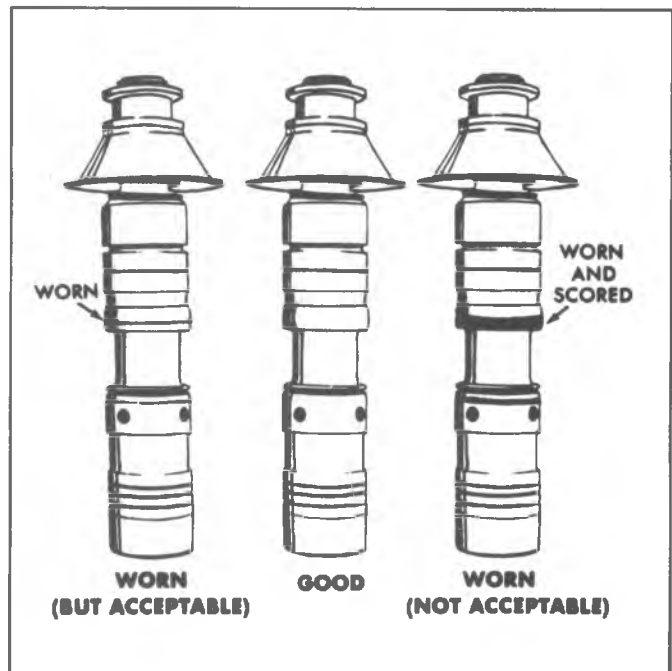

Fig. 5-B4--Spool Valve Inspection

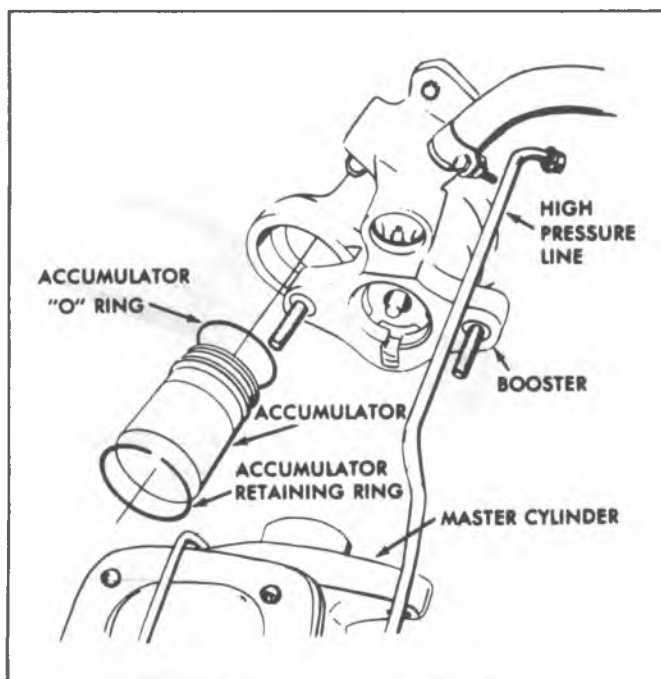

Fig. 5-B7--Accumulator Installation

**NOTICE:** Be sure to keep parts clean until reassembly. Wash at reassembly if there are any parts dropped or left exposed for eight hours or longer. Lubricate all seals and metal friction points with power steering fluid. Whenever the booster is disassembled and all disturbed seals and damaged tube inserts should be replaced. All of these parts are included in a kit. If any of the accumulator valve components are damaged or lost, replace all the valve components.

1. Clean all metal parts in a suitable solvent. Be careful to avoid losing small parts.
2. Inspect the valve spool and the valve spool bore in the housing for corrosion, nicks, scoring or other damage. Discoloration of the spool or bore, particularly in the grooves, is not harmful and is no cause for replacement.
3. If the valve spool or the valve spool bore has

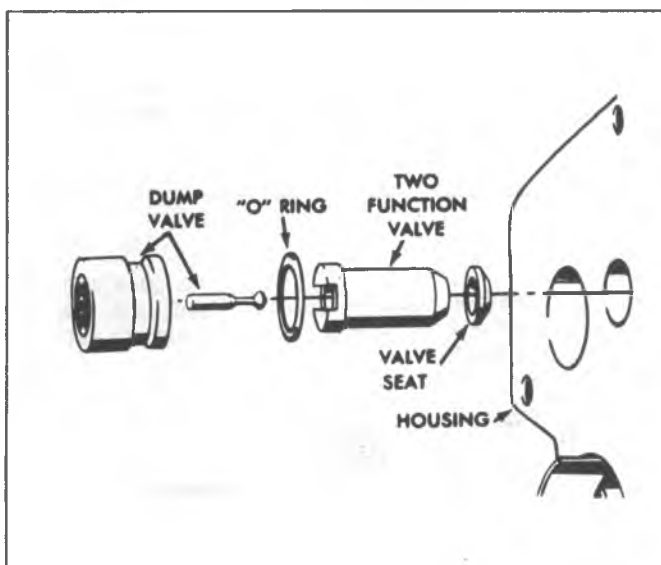

Fig. 5-B8--Accumulator Valves

nicks or scoring that can be felt with a fingernail particularly on the lands, the entire booster should be replaced as an assembly.

The clearance between the spool valve and the spool valve bore of the housing assembly is important. Because of this, the valve spool valve and the housing assembly make up a selective assembly. The spool valve is selected to match the spool valve bore.

4. Inspect the piston for scratches, nicks, etc. If scratches on the outside diameter can be felt with a fingernail, the input rod and piston must be replaced.

### Assembly

1. Install "O" ring and spool valve plug (Fig. 5-B9).
2. Install "O" ring and spool valve plug (Fig. 5-B9).
3. Push spool valve plug in and install retaining ring.
4. Coat the piston bore and the piston seal with clean power steering fluid, and assemble the **NEW** seal in the bore. The lip of the seal must be toward the rear (away from the master cylinder mounting flange). Be sure the seal is fully seated in the housing.
5. Lubricate the input rod end, **NEW** input rod seals and Seal Installer with clean power steering fluid. Slide the seals on the tool with the lip of the cups toward the open end of the tool (Fig. 5-B12).
6. Slide the tool over the input rod end and down to the second groove; then slide the forward seal off the tool and into the groove. Assemble the other seal in the first groove. Be sure that both seals are fully seated. Only one seal is used on JD3 and JD5 applications.
7. The piston counterbore on JF9 applications is of a different diameter than on JB8. Remove the pilot portion of Tool J-24551.
8. Lubricate the piston and Piston Installing Tool with clean power steering fluid. Hold the large end of the tool against the piston (Fig. 5-B13), and slide the tool and piston into the piston bore and

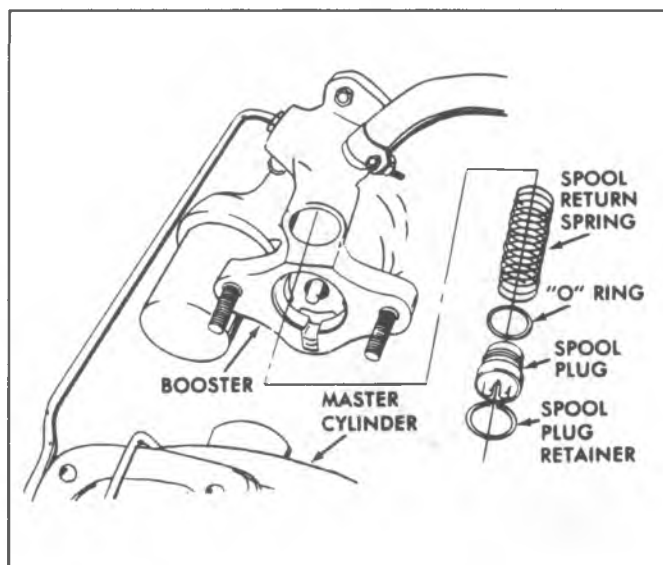

Fig. 5-B9--Spool Valve Plug Removal

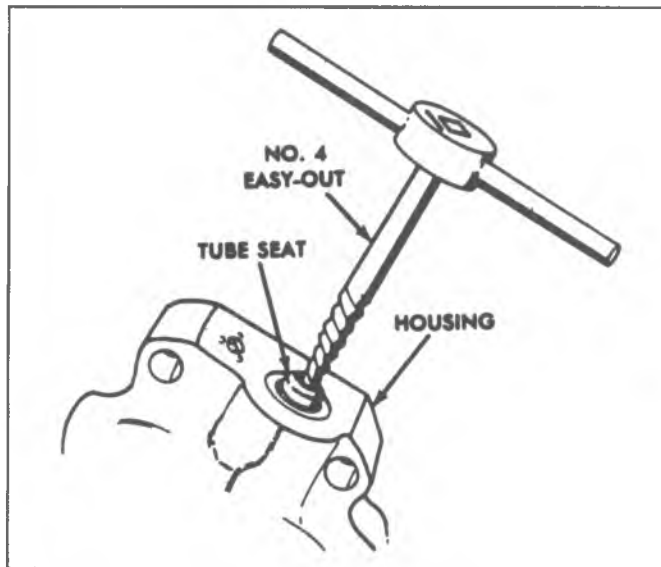

Fig. 5-B10--Removing Tube Seat

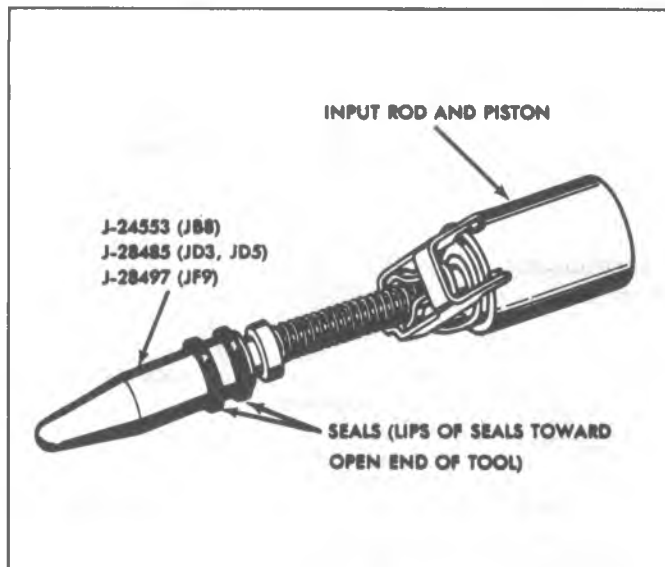

Fig. 5-B12--Installing Input Rod Seals

- through the piston seal. Remove piston installing tool.
9. If removed, install return hose fitting with new "O" ring.
  10. If accumulator valve was removed, install new seal into the valve bore. The seat can be forced to the bottom by installing the two function valve (Fig. 5-B8). Make certain the check valve seat is cup side up when in bore.
  11. If removed, insert new dump valve over the two function valve making certain that the dump valve plunger is held in place until installation is complete.
  12. Insert spool valve spring and spool valve assembly into bore in housing. Extend power piston lever to accept sleeve on spool valve, then slide lever pins into slot in sleeve.

13. Position a NEW "figure eight" seal in the groove in the housing cover. Then join the booster housing and cover and secure with five screws. Tighten the screws to 20 ft. lbs.

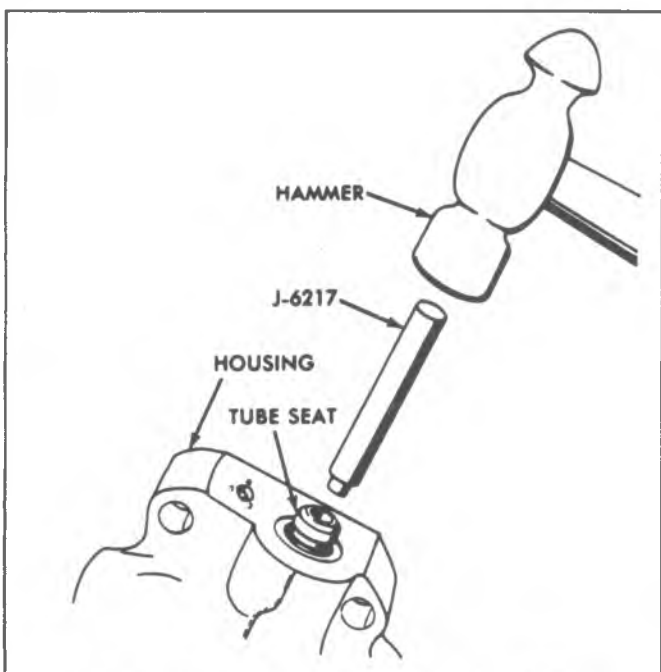

Fig. 5-B11--Installing Tube Seat Using J-6217

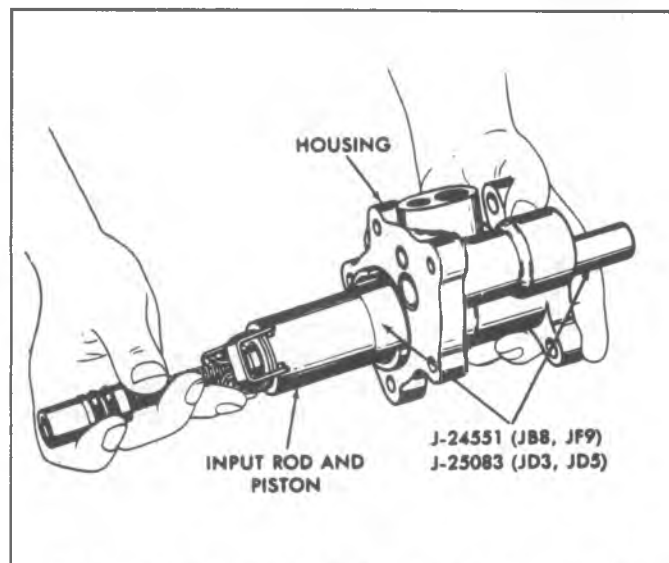

Fig. 5-B13--Installing Input Rod and Piston Assembly Into Booster (Typical)

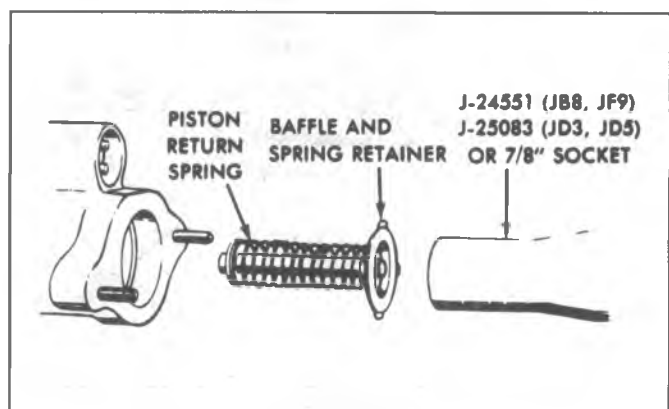

Fig. 5-B14--Installing Baffle and Spring Retainer

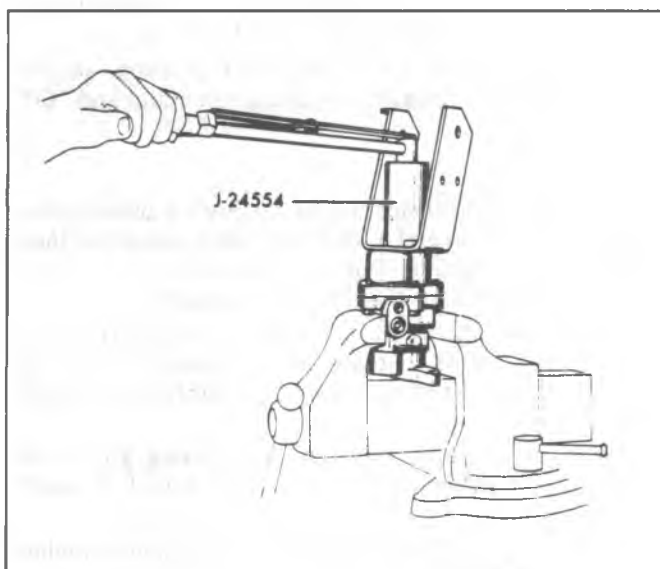

Fig. 5-B15--Installing Mounting Bracket Nut

**NOTICE:** See "Notice" on Page 1 of this section.

14. Install output rod, spring and new spring retainer.
  15. Secure new baffle and spring retainer using Piston Installing Tool or 7/8" socket as shown in Figure 5-B14.
  16. Using clean power steering fluid, lubricate accumulator seal. Install seal and accumulator in housing and then place the retaining ring over the accumulator (Fig. 5-B7). Place Tool J-26889 over accumulator.
  17. Using Tool J-22269-01 or a large "C" clamp (6" minimum), depress the accumulator making certain that the accumulator is compressed straight (Fig. 5-B6).
  18. Snap the retaining ring into the housing groove by pushing it down all the way around with a small screwdriver.
  19. Remove Tool J-22269-01 or "C" clamp and retaining cap Tool J-26889.
- NOTICE:** Carefully check to make sure the retaining ring was completely installed properly.
20. Position the mounting bracket on the booster. The tab on the inside diameter of the large hole in the bracket should fit into a slot in the threaded portion of the booster hub.
  21. Install the **NEW** bracket nut with the staking groove outward on the threaded hub of the booster. Using Tool J-24554 and a torque wrench (Fig. 5-B15), tighten the nut to 110 ft. lbs.

**NOTICE:** See "Notice" on Page 1 of this section.

22. Use a hammer and a small punch inserted into the staking groove of the nut, at the slot in the booster hub (Fig. 5-B16) to stake the nut in place. Be sure that the outer thread of the nut is upset.
23. Assemble a boot (if used) on the pedal rod. Then assemble a **NEW** grommet in the groove near the end of the pedal rod.

24. Moisten the grommet with water (to ease assembly), and insert the grommet end of the pedal rod into the input rod end of the booster housing. Push on the end of the pedal rod to seat the grommet in the groove inside the housing. When the grommet is fully seated, the pedal rod will rotate freely with no binding.
25. Slide the boot on the pedal rod and assemble the large end of the boot onto the hub of the power section.

### HYDRO-BOOST BLEEDING PROCEDURE

Whenever the booster is removed and reinstalled, the steering system should be bled as outlined below.

**NOTICE:** Power steering fluid and brake fluid cannot be mixed. If brake seals contact steering fluid or steering seals contact brake fluid, seal damage will result.

1. Fill oil reservoir to proper level and let oil remain undisturbed for at least two minutes.
2. Start engine and run momentarily.
3. Add oil, if necessary.
4. Repeat above procedure until oil level remains constant after running engine.
5. Raise front end of vehicle so that wheels are off the ground.
6. Turn the wheels (off ground) right and left, lightly contacting the wheel stops.
7. Add oil if necessary.
8. Lower the vehicle.
9. Start engine and depress the brake pedal several times while rotating the steering wheel from stop to stop.
10. Turn engine off and then pump brake pedal 4-5 times to deplete accumulator pressure.
11. Check oil level and refill as required.
12. If oil is extremely foamy, allow vehicle to stand a few minutes with engine off and repeat above procedure.

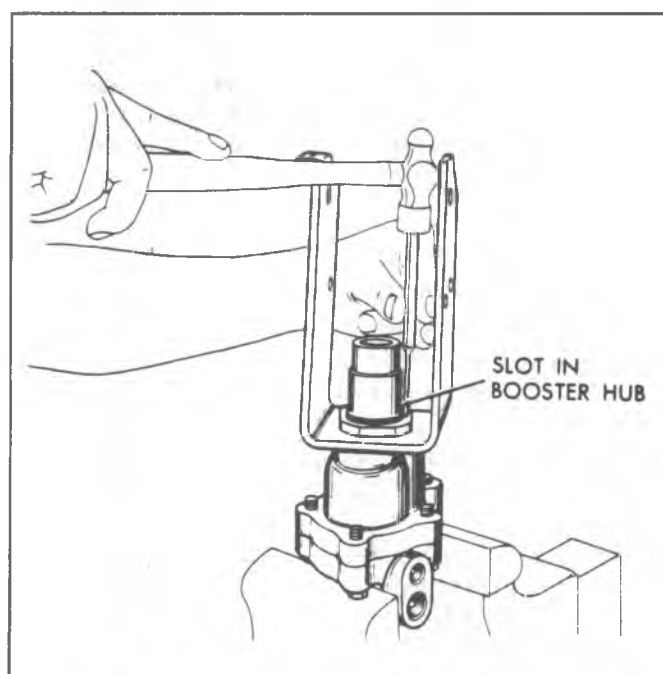

Fig. 5-B16--Staking Mounting Bracket Nut



- a. Check belt tightness and check for a bent pulley. (Pulley should not wobble with engine running.)
  - b. Check to make sure hoses are not touching any other parts of the vehicle, particularly sheet metal.
  - c. Check oil level, filling to proper level if necessary, following operations 1 through 10. This step and Step "d" are extremely important as low oil level and/or air in the oil are the most frequent causes of objectionable pump noises.
  - d. Check the presence of air in the oil. Air will show up as milky appearing oil. If air is present, attempt to bleed system as described in operations 1 through 10. If it becomes obvious that the pump will not bleed after a few trials, proceed as outlined under Power Steering System Test Procedure in the "Steering" Section of this manual.
13. The presence of trapped air in the system will cause the fluid level in the pump to rise when the engine is turned off. Continue to bleed system until this condition no longer occurs.

## HYDRO-BOOST BRAKE SYSTEM

**NOTICE:** Power steering fluid and brake fluid cannot be mixed. If brake seals contact steering fluid or steering seals contact brake fluid, seal damage will result.

The following operations can be performed with the booster installed in the vehicle; exceptions to this statement may exist where Body Manufacturers sheet metal ("P" Models) would require removal of the booster from the vehicle.

### Pneumatic Accumulator

**CAUTION:** The accumulator contains compressed gas. Always use proper tools and follow recommended procedures or personal injury may result. Do not apply heat to accumulator. Do not attempt to repair an inoperative accumulator, always replace with a new accumulator. Dispose of an inoperative accumulator by drilling a 1/16" (1.6mm) diameter hole through the end of the accumulator can opposite the "O" ring.

#### Removal

1. Turn engine off and pump brake pedal 4 or 5 times to deplete accumulator.
2. Disconnect the high pressure hose.
3. Remove two nuts from master cylinder, then move master cylinder away from booster with brake lines attached.
4. Place the accumulator retaining cap Tool J-26889 over the master cylinder stud and install the nut as shown in Figure 5-34.
5. Using Tool J-22269-01 or a large "C" clamp (6" (150 mm) minimum), depress the accumulator. Insert a punch into the hole in the housing and remove retaining ring with a small screwdriver (Fig. 5-34).

If the accumulator is not easily compressed approximately 1/8" (3mm) it is still charged. This

indicates an internal problem with the accumulator valves and the booster must be disassembled.

6. Slowly back off the clamp until tension on the accumulator is released; remove accumulator and "O" ring.

#### Installation

1. Using clean power steering fluid, lubricate accumulator seal. Install seal and accumulator in housing and then place the retaining ring over the accumulator (Fig. 5-35). Place Tool J-26889 over accumulator.
2. Using Tool J-22269-01 or a large "C" clamp (6" (150 mm) minimum), depress the accumulator making certain that the accumulator is compressed straight (Fig. 5-34).
3. Snap the retaining ring into the housing groove by pushing it down all the way around with a small screwdriver.
4. Remove Tool J-22269-01 or "C" clamp and retaining cap Tool J-26889.

**Carefully check to make sure the retaining ring was completely installed properly.**

5. Connect high pressure hose and check power steering fluid.
6. Install the master cylinder two nuts and accumulator retaining cap Tool J-26889 and close the vehicle hood. Test the unit by starting the engine and turning the steering wheel from stop to stop a few times. Turn off engine and apply brake pedal 4 or 5 times.
7. Remove accumulator retaining cap Tool J-26889 and install master cylinder nut.

**NOTICE:** See "Notice" on Page 1 of this section.

### Spool Valve Plug

#### Removal

1. Turn engine off and pump brake pedal 4 or 5 times to deplete accumulator.
2. Remove two nuts from master cylinder, then move master cylinder away from brake lines attached.
3. Push spool valve plug in and use a small screwdriver to remove retaining ring (Fig. 5-36).
4. Remove spool valve plug and "O" ring.

#### Installation

1. Install "O" ring and spool valve plug (Fig. 5-36).
2. Push spool valve plug in and install retaining ring.
3. Install master cylinder and two nuts to booster.

**NOTICE:** See "Notice" on Page 1 of this section.

4. Bleed system. Refer to "HYDRO-BOOST BLEEDING PROCEDURE"

### Tube Seat

#### Replacement

1. Turn engine off and pump brake pedal 4 or 5 times to deplete accumulator.
2. Clean dirt around fitting before removing fitting, then disconnect pressure hose at Hydro-Boost and secure hose in a raised position to prevent loss of fluid.



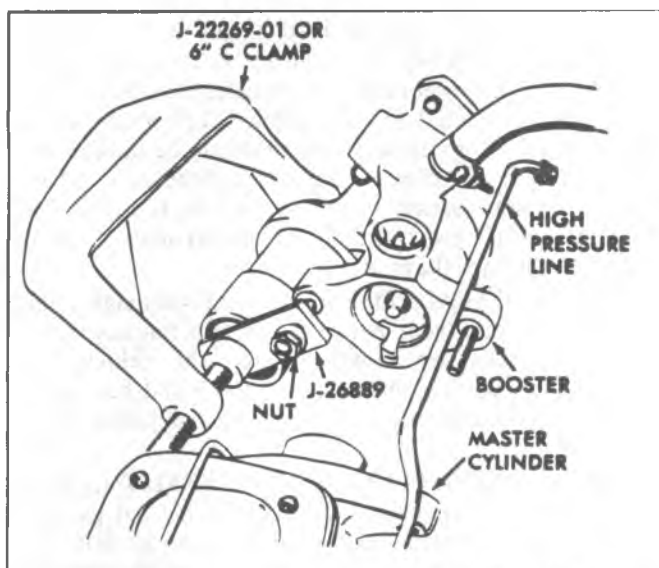

Fig. 5-34—Compressing Accumulator With J-26889

3. To prevent metal chips from entering booster, pack inside of tube seat with petrolatum.
4. Remove tube seat using No. 4 easy-out as shown in Figure 5-37.
5. Wipe petrolatum from housing and clean housing thoroughly to remove any metal chips or dirt.
6. Install tube seat with Tool J-6217 as shown in Figure 5-55.
7. Fill and bleed system. Refer to "HYDRO-BOOST BLEEDING PROCEDURE".

## Hydro-Boost Unit

### Replacement (Figs. 5-39 thru 5-42)

1. Depress and release the brake pedal several times (engine not running) to be sure that all pressure is discharged from the accumulator prior to

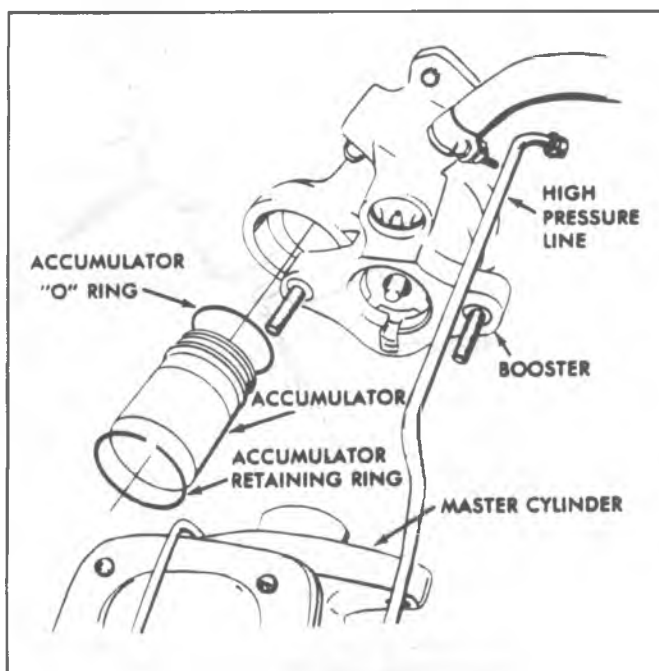

Fig. 5-35—Accumulator Installation

- disconnecting the hoses from the booster.
2. **P30(32) Models** - Raise the vehicle on a hoist.
3. Clean all dirt from the booster at the hydraulic line connections and master cylinder.
4. Remove the nuts and lockwashers that secure the master cylinder to the booster and the support bracket. Support the master cylinder, being careful to avoid kinking or bending the hydraulic lines attached to the master cylinder. Cover the end of the master cylinder with a clean cloth.
- It should not be necessary to disconnect the hydraulic lines from the master cylinder.
5. Disconnect the hydraulic lines from the booster ports. Plug all lines and the booster ports to prevent loss of fluid and to keep out foreign materials.

### 6. P30(42) and C-K-G Models-

- a. Remove booster pedal push rod cotter pin and washer and disconnect the push rod from the brake pedal (C and K models) or booster bracket pivot lever (G and P models).
- b. Remove the lower dash trim, then lower the steering column on C and K models. Remove support brackets on P30 (42) models.
- c. Remove the booster bracket to dash panel or support bracket nuts and remove the booster assembly.

### 7. P30(32) Models-

- a. Remove the cotter pin, nut bolt and washers that secure the operating lever to the vertical brake rod.
- b. Remove the six nuts, lock washer and bolts that secure the booster linkage bracket to the front and rear support brackets, and remove the booster from the vehicle by sliding the booster off the rear support studs.
- c. Remove the cotter pin, nut, washer and bolt that secures the operating lever to the pedal rod.
- d. Remove the brake pedal rod lever nut and bolt and then remove the lever, sleeve and bushing.

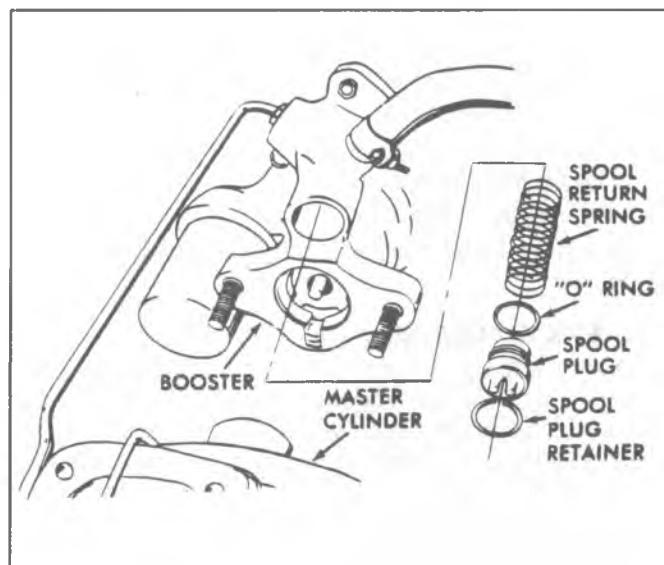

Fig. 5-36—Spool Valve Plug Removal

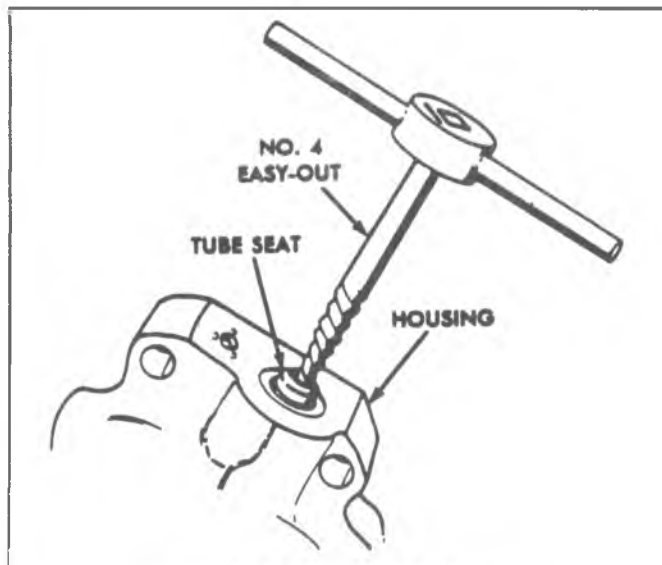

Fig. 5-37--Removing Tube Seat

- To install, reverse Steps 1-7 above. Torque all hydraulic lines and attaching bolts to specifications. Lubricate pedal rod and linkage pivot bolts, pins, sleeves and bushings with Delco Brake Lube (or equivalent).

**NOTICE:** See "Notice" on Page 1 of this section.

- Fill and bleed system. Refer to "Hydro-Boost Bleeding Procedure."
- Check brake pedal and stoplamp switch adjustment.

### HYDRO-BOOST DIAGNOSIS

Prior to performing the Booster Function Tests, or the Accumulator Leakdown Test, the following preliminary checks must be made:

**NOTICE:** Power steering fluid and brake fluid cannot be mixed. If brake seals contact steering fluid or steering seals contact brake fluid, seal damage will result.

- Check all power steering and brake lines and connections for leaks and/or restrictions.
- Check and fill brake master cylinder with **BRAKE FLUID**.
- Check and fill power steering pump reservoir with **POWER STEERING FLUID**. Be sure fluid is not aerated (air mixed with fluid).
- Check power steering pump belt for tension and/or damage. Adjust if necessary.
- Check engine idle speed and adjust if necessary.
- Check steering pump pressure. Refer to Power Steering Section.

### SEAL LEAK DIAGNOSIS (FIG. 5-1H)

- INPUT ROD SEAL.** A damaged seal will show up as a fluid leak from the mounting bracket vent hole. The booster must be removed from the vehicle and disassembled. The input rod bore should be checked for any scratches that may cause the leak. If scratches are present, housing cover must be replaced. If no excessive scratches are present, then the booster seal kit can be used to replace the appropriate seals.

- POWER PISTON SEAL.** Power piston seal damage will be noticed by fluid leaking out at the common master cylinder-brake booster vent and possible reduction in power assist. The booster must be removed from the vehicle and disassembled. The piston should be checked for any scratches that may be the cause of the leak. If scratches are present, then the input rod and power piston assembly must be replaced. If no excessive scratches are present, then the booster seal kit can be used to replace the appropriate seals.
- HOUSING SEAL.** If the housing seal is damaged, fluid will leak out from between the two housings. The booster must be removed from the vehicle and disassembled. The booster seal kit should be used to replace the housing and input rod and power piston seals.
- SPOOL VALVE PLUG "O" RING SEAL.** Damage to this seal will be noticed by fluid leaking out past the plug. The booster need not be removed from the vehicle. The master cylinder should be disconnected from the booster.

Press in on spool plug, insert a small screwdriver between snap ring and housing bore. This unseats one side of the spool plug snap ring from its groove in the bore. Then remove the snap ring from the bore.

- ACCUMULATOR "O" RING SEAL.** Damage to this seal will result in fluid leakage past the accumulator cap. The seal can be replaced while the booster is installed on the vehicle. A catch basin should be placed under the booster to catch the fluid when the accumulator or spring cap is removed.

**CAUTION:** Before removing the cap, the brake pedal must be pumped 4-5 time to deplete accumulator pressure. Refer to "Pneumatic Accumulator On-Vehicle Service Procedure".

- EXTERNAL LEAKAGE AT THE RETURN PORT FITTING.** Tighten fitting to 7lb. ft. (10 N·m). If it

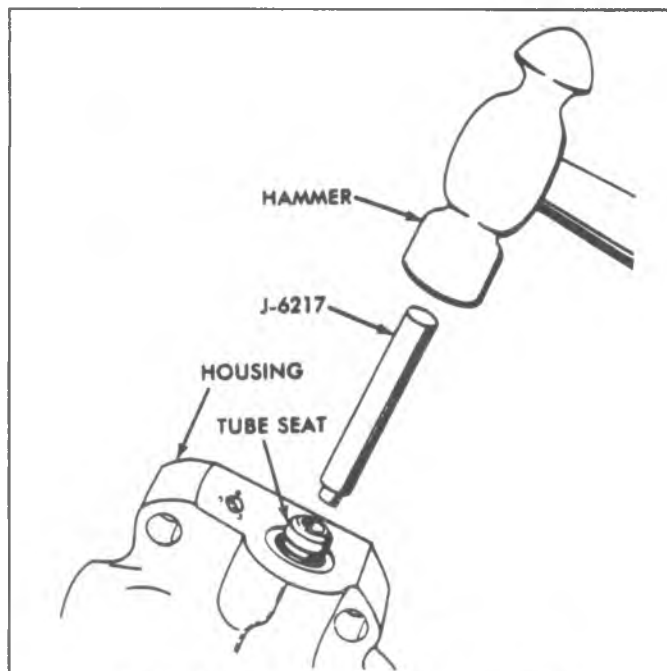

Fig. 5-38--Installing Tube Seat Using J-6217

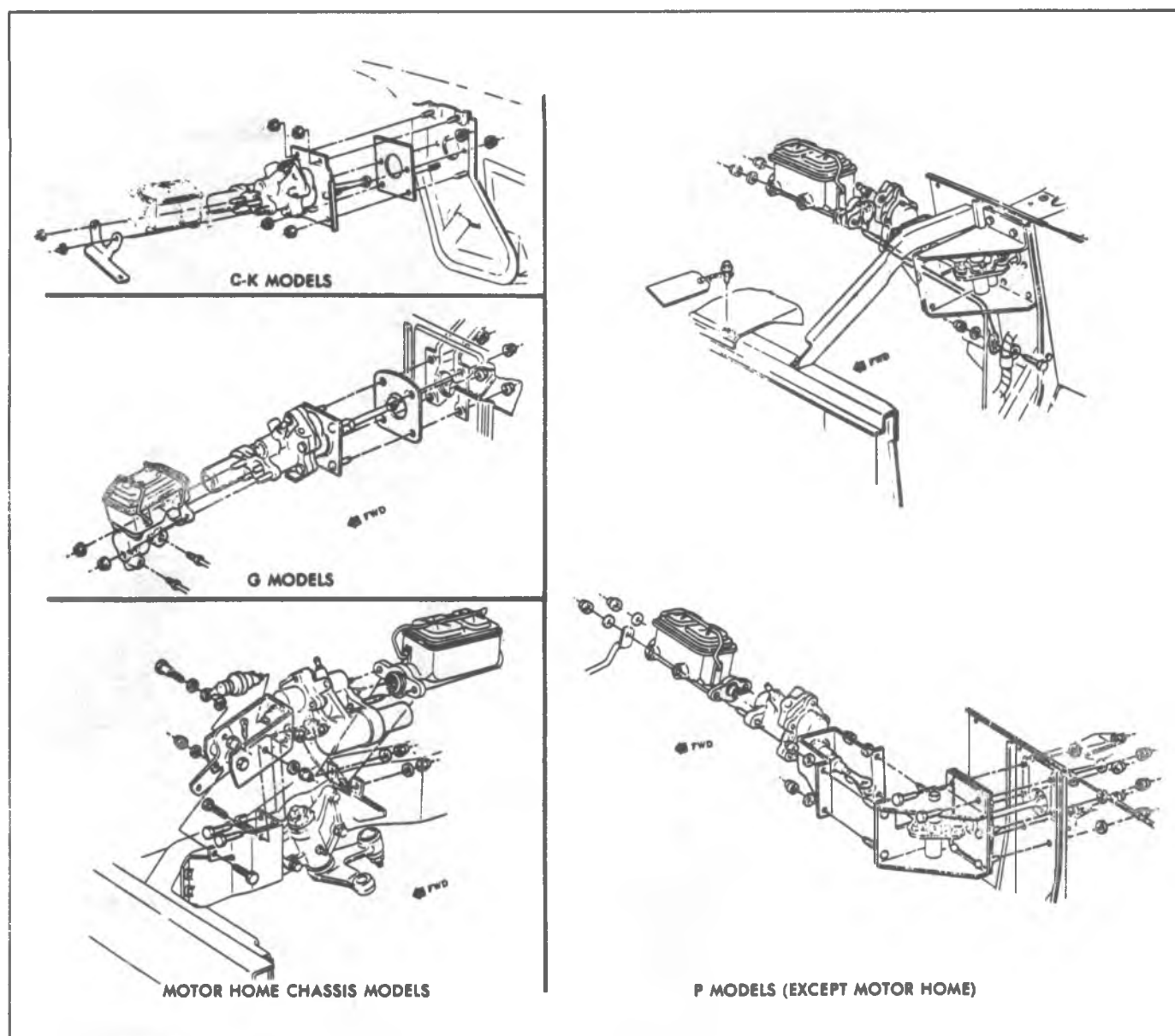

Fig. 5-39--Booster Installation (Hydro-Boost)

continues to leak, replaced "O" ring under fitting.

7. **EXTERNAL LEAKAGE AT THE HIGH PRESSURE GEAR OR PUMP.** Torque tube nut to 30 lb. ft. (40 N·m). If it continues to leak, check for damaged tube flares; if OK, replace tube seats.

### TROUBLE SHOOTING AND TESTING (FIG. 5-HB)

The Hydro-Boost differs from vacuum brake boosters not only in the source of power (hydraulic versus vacuum) but in the fact that it is also a part of another major sub-system of vehicle--the power steering system. Therefore, problems or malfunctions in the steering system may affect the operation of the booster, just as a problem in the booster may affect the steering system. The following noises are associated with the Hydro-boost system and may or may not be cause for customer complaint. Some are normal and for the most part temporary in nature. Others may be a sign of excessive wear or the presence of air in either the booster or the steering system.

1. Moan or low frequency hum usually accompanied by a vibration in the pedal and/or steering column may be observed during parking maneuvers or other very low speed maneuvers. This may be caused by a low fluid level in the power steering pump or by air in the power steering fluid due to holding the pump at relief pressure (steering wheel held all the way in one direction) for an excessive amount of time (more than 5 seconds). Check the fluid level and fill to make. System must sit for one hour to remove the air. If the condition persists, this may be a sign of excessive pump wear and the pump should be checked. Refer to the Power Steering Section.
2. At or near power runoff, (Brake pedal near fully depressed position) a high speed fluid noise (faucet type) may be heard. This is a normal condition and will not be heard except in emergency braking conditions, or with vehicle stopped and pedal pushed near fully depressed position.
3. Whenever the accumulator pressure is used, a slight hiss may be noticed. It is the sound of the hydraulic

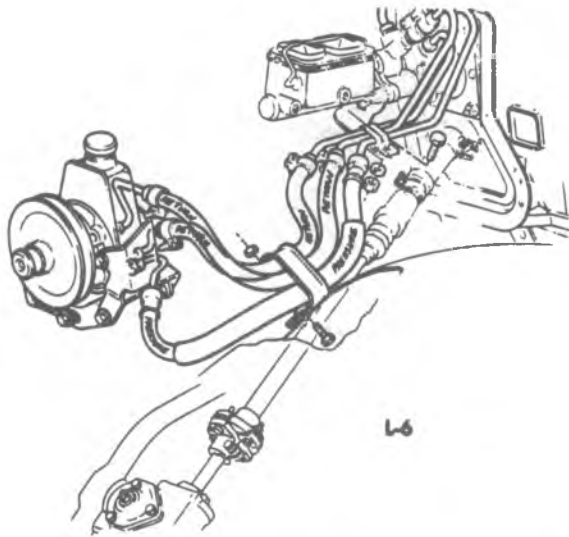

L-6

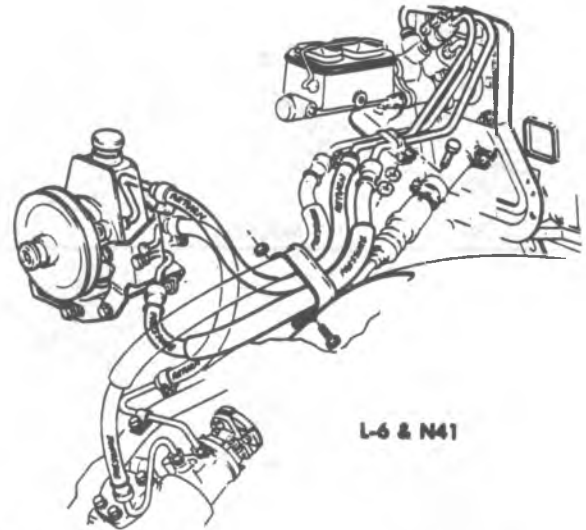

L-6 & N41

C MODELS

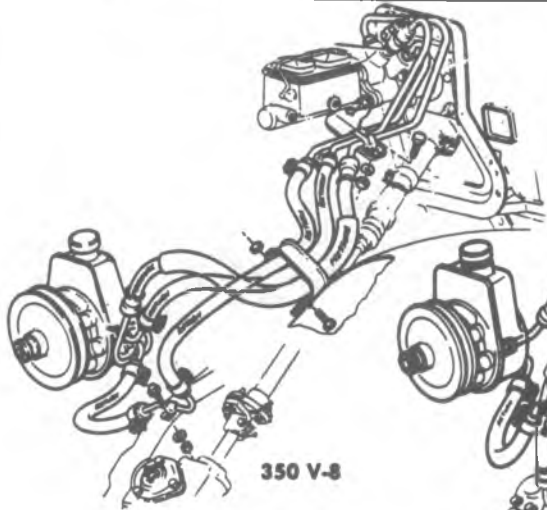

350 V-8



350 V-8 DIESEL

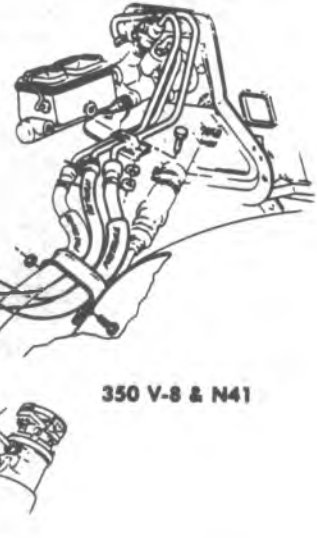

350 V-8 & N41

C MODELS

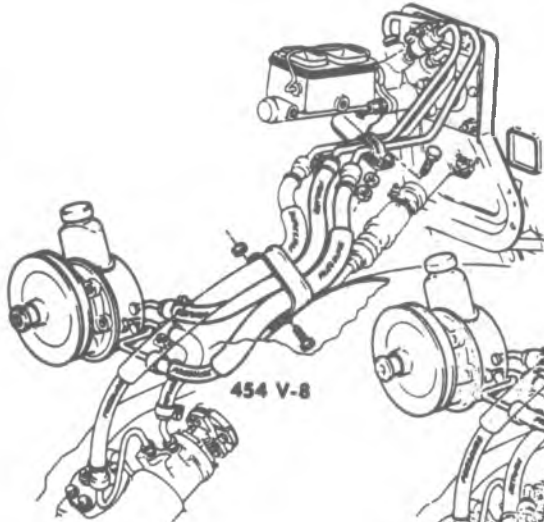

454 V-8

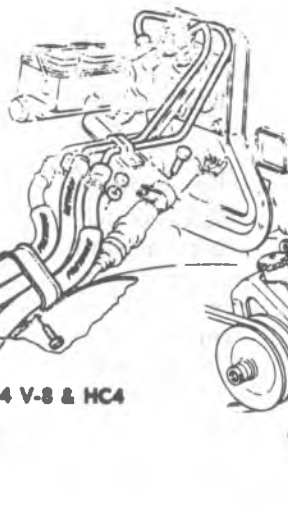

454 V-8 & HC4

C MODELS

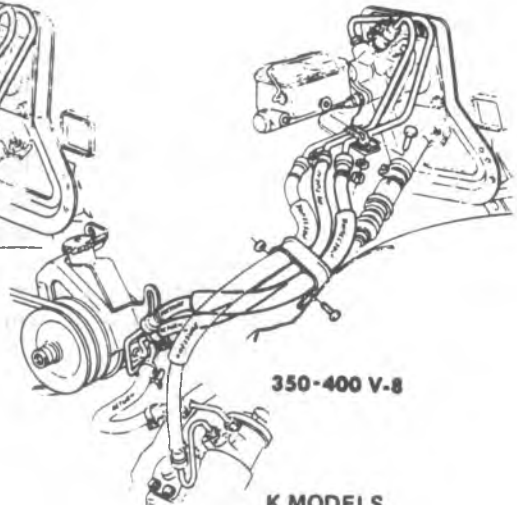

350-400 V-8

K MODELS

Fig. 5-40--Power Steering Hose Routing-C-K Models

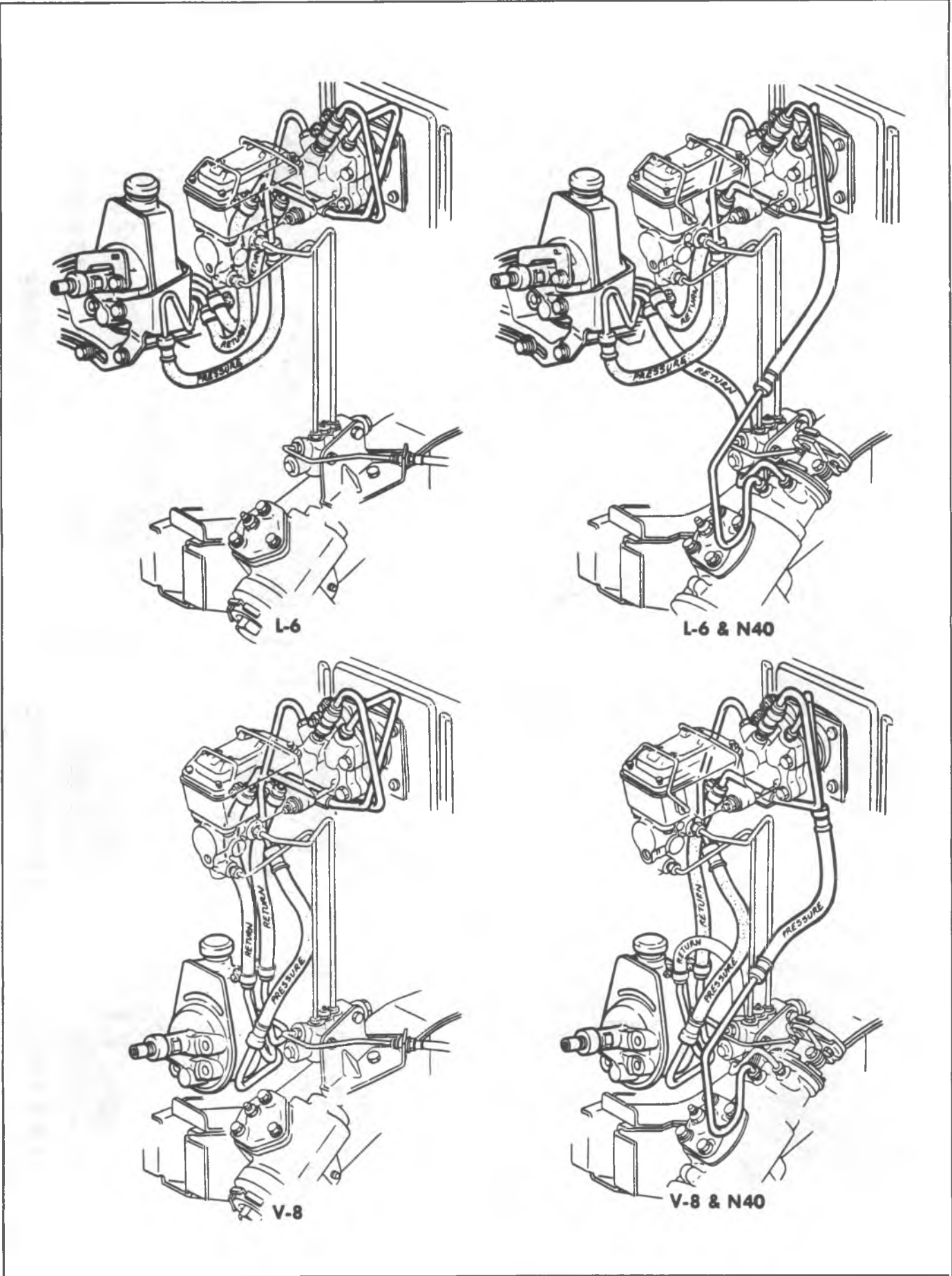
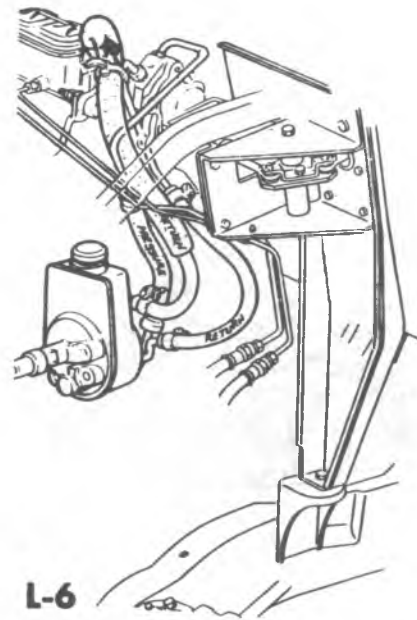
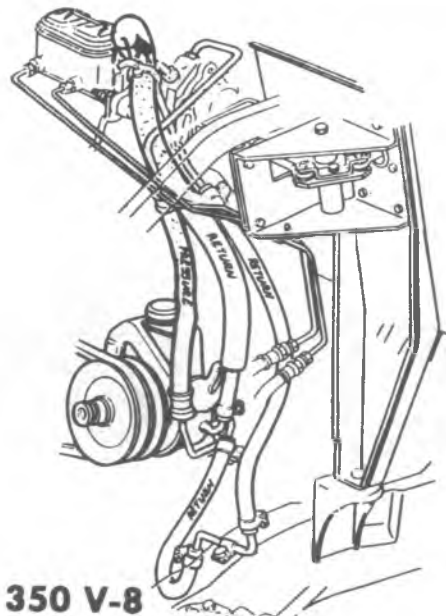

Fig. 5-41--Power Steering Hose Routing-G Models





L-6



350 V-8

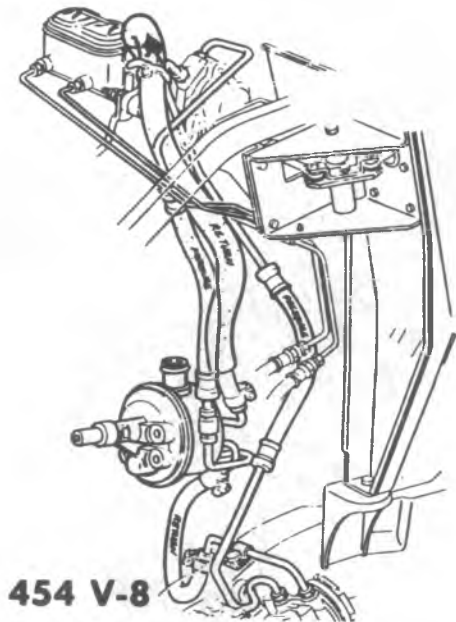

454 V-8

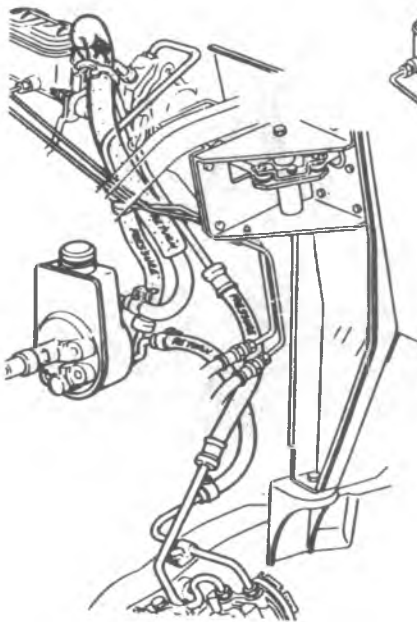

L6 & N40

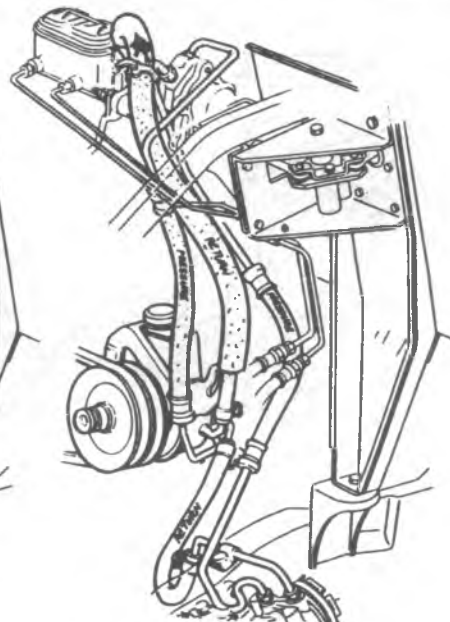

350 V-8 & N40

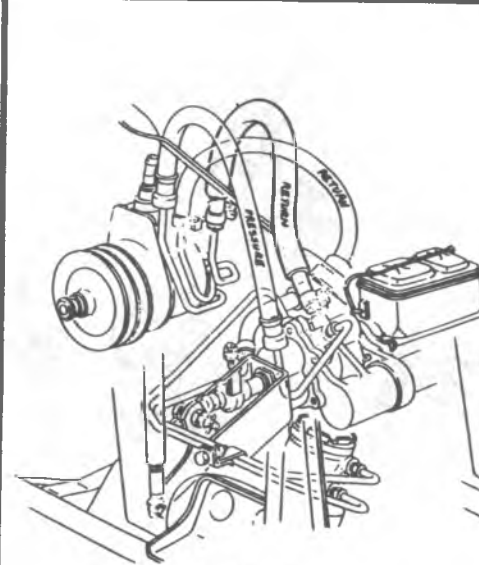

350 V-8



454 V-8

MOTOR HOME

Fig. 5-42--Power Steering Hose Routing-P Models

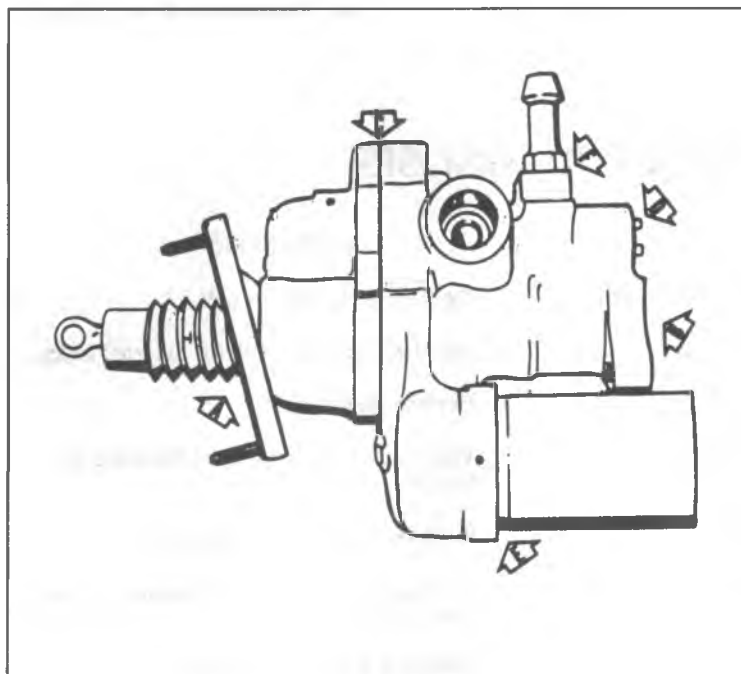

### HYDRO— BOOST SEAL LEAKAGE

- A. **INPUT SEAL LEAK** — Fluid leakage from housing cover end of booster near reaction bore. Replace seal(s).
- B. **PISTON SEAL LEAK** — Fluid leakage from vent at front of unit near master cylinder. Replace seal.
- C. **HOUSING** — Fluid leakage between the housing and housing cover. Replace seal.
- D. **SPOOL VALVE SEAL** — Fluid leakage near plug area. Replace seal.
- E. **ACCUMULATOR CAP SEAL** — Fluid leakage from accumulator area. Replace seal.
- F. **RETURN PORT FITTING SEAL** — Replace seal.

Fig. 5-1H--Seal Leakage Diagnosis

fluid escaping through the accumulator valve, and is completely normal.

4. After the accumulator has been emptied, and the engine is started again, another hissing sound may be heard during the first brake application or the first steering maneuver. This is caused by the fluid rushing through the accumulator charging orifice. It is normal and will only be heard once after the accumulator is emptied. However, if this sound continues, even though no apparent accumulator pressure assist was made, it could be an indication that the accumulator is not holding pressure and should be checked using the procedure for "ACCUMULATOR LEAKDOWN TEST".
5. After bleeding, a "gulping" sound may be present during brake applications as noted in the bleeding instructions.

### CHECKING THE RESERVE SYSTEM

1. Start engine and charge accumulator by applying the brake pedal or by turning the steering wheel from stop to stop. Turn off engine and let vehicle sit for one hour. After one hour there should be at least two power assisted applications with the engine off.
2. If the reserve system will not retain a charge for one hour, but functions normally immediately following

charging, the accumulator valves are at fault and the booster must be disassembled and the accumulator valves replaced.

3. If the accumulator can be heard charging and discharging, but it does not hold a charge, disassemble the booster and replace the accumulator valves.
4. Deplete the accumulator by pressing the brake pedal 4 or 5 times. If the accumulator can has lost its gas charge, it is possible to rotate or wobble the accumulator can with respect to the housing. Replace the accumulator assembly.

### BOOSTER FUNCTIONAL TEST

With the engine off, apply the brake pedal several times until the accumulator is completely depleted. Depress the brake pedal (approximately 40 pounds/180 N pedal force) and start the engine. The pedal should fall and then push back against driver's foot.

### ACCUMULATOR LEAKDOWN TEST

Start engine and charge accumulator by either applying the brake pedal (approximately 100 pounds/450 N force) or by turning the steering wheel from stop to stop. Turn off engine and let vehicle sit for one hour. After one hour, there should be two power assisted applies with engine stopped.

## HYDRO — BOOST DIAGNOSIS

| CONDITION  | CAUSE  | CORRECTION  |
|--|--|---|
| <b>Excessive Brake Pedal Effort</b>                      | Loose or broken power steering pump belt.                          | Tighten or replace the belt.                              |
|  | No fluid in power steering reservoir.                              | Fill reservoir and check for external leaks.              |
|  | Leaks in Hydro-Boost   | Replace faulty parts.                                     |
|  | Leaks at Hydro-Boost tube fittings.                                | Tighten fittings or replace tube seats, if faulty.        |
|  | External leakage at accumulator                                    | Replace "O" ring and retainer.                            |
|  | Faulty booster piston seal causing leakage at booster flange vent. | Overhaul with new seal or input rod and piston assembly.  |
|  | Faulty booster input rod seal with leakage at input rod end.       | Overhaul with new seal kit.                               |
| <b>Slow Brake Pedal Return</b>                           | Faulty booster cover seal with leakage between housing and cover.  | Overhaul with new seal kit.                               |
|  | Faulty booster spool plug seal.                                    | Overhaul with spool plug seal kit.                        |
|  | Excessive seal friction in booster.                                | Overhaul with new seal kit.                               |
|  | Faulty spool action.   | Flush steering system while pumping brake pedal.          |
|  | Restriction in return line from booster to pump reservoir.         | Replace line.   |
| <b>Grabby Brakes</b>                                     | Damaged input rod end.   | Replace input rod and piston assembly.                    |
|  | Faulty spool action caused by contamination in system.             | Flush steering system while pumping brake pedal.          |
| <b>Booster Chatters - Pedal Vibrates</b>                 | Power steering pump belt slips.                                    | Tighten belt.   |
|  | Low fluid level in power steering pump reservoir.                  | Fill reservoir and check for external leaks.              |
|  | Faulty spool operation caused by contamination in system.          | Flush steering system while pumping brake pedal.          |
| <b>Accumulator Leak Down-System does not hold charge</b> | Contamination in steering hydro-boost system                       | Flush steering system while pumping brake pedal           |
|  | Internal leakage in accumulator system                             | Overhaul unit using accumulator rebuild kit and seal kit. |

Fig. 5-HB--Hydro-Boost Diagnosis



## BRAKE SYSTEM DESCRIPTION

| <u>SYSTEM</u>                          | <u>FRONT BRAKES</u> | <u>REAR BRAKES</u> | <u>BRAKE ASSIST</u>       |
|--|---------------------|--------------------|---------------------------|
| <b><u>GASOLINE ENGINE VEHICLES</u></b> |                     |                    |                           |
| <b><u>C-MODELS</u></b>                 |                     |                    |                           |
| JB1 Low Drag                           | Disc 11.86 x 1.04   | Drum 11.00 x 2.00  | None (Manual Brakes)      |
| JB3 Low Drag                           | Disc 11.86 x 1.04   | Drum 11.00 x 2.00  | Vacuum — Single Diaphragm |
| <b><u>G-MODELS</u></b>                 |                     |                    |                           |
| JB1 Low Drag                           | Disc 11.86 x 1.28   | Drum 11.00 x 2.00  | None (Manual Brakes)      |
| JB3 Low Drag                           | Disc 11.86 x 1.28   | Drum 11.00 x 2.00  | Vacuum — Single Diaphragm |
| <b><u>ALL MODELS</u></b>               |                     |                    |                           |
| JB5 Low Drag                           | Disc 11.86 x 1.28   | Drum 11.15 x 2.75  | Vacuum — Dual Diaphragm   |
| JB6 Low Drag                           | Disc 12.50 x 1.28   | Drum 11.15 x 2.75  | Vacuum — Dual Diaphragm   |
| JB7 Conventional                       | Disc 12.50 x 1.28   | Drum 13.00 x 2.50  | Vacuum — Dual Diaphragm   |
| JB8 Conventional                       | Disc 12.50 x 1.53   | Drum 13.00 x 3.50  | Hydraulic — Hydroboost    |
| JB9 Conventional                       | Disc 14.25 x 1.53   | Disc 13.75 x 1.53  | Hydraulic — Hydroboost    |
| <b><u>DIESEL ENGINE VEHICLES</u></b>   |                     |                    |                           |
| JD3 Low Drag                           | Disc 11.86 x 1.28   | Drum 11.00 x 2.00  | Hydraulic — Hydroboost    |
| JD5 Low Drag                           | Disc 11.86 x 1.28   | Drum 11.15 x 2.75  | Hydraulic — Hydroboost    |

| DRUM DIAMETERS |                  |                          |
|----------------|------------------|--------------------------|
| ORIGINAL       | MAXIMUM REFINISH | REPLACEMENT<br>(DISCARD) |
| 11.000         | 11.060           | 11.090                   |
| 11.150         | 11.210           | 11.240                   |
| 12.000         | 12.060           | 12.090                   |
| 13.000         | 13.060           | 13.090                   |

| ROTOR THICKNESS              |                          |
|------------------------------|--------------------------|
| MINIMUM<br>AFTER REFINISHING | REPLACEMENT<br>(DISCARD) |
| 1.480                        | 1.465                    |
| 1.230                        | 1.215                    |
| .980                         | .965                     |

|                                       | C  | K                      | G                     | P                     |
|---------------------------------------|--|------------------------|-----------------------|-----------------------|
| Master Cylinder — to Dash or Booster  | **34 N•m (25 ft. lbs.)   | **34 N•m (25 ft. lbs.) | 34 N•m (25 ft. lbs.)  | 34 N•m (25 ft. lbs.)  |
| Booster to Dash or Frame              | **34 N•m (25 ft. lbs.)   | **34 N•m (25 ft. lbs.) | 34 N•m (25 ft. lbs.)  | 34 N•m (25 ft. lbs.)  |
| Combination Valve — Mounting Bolts    | 17 N•m (150 in. lbs.)  | 17 N•m (150 in. lbs.)  | 23 N•m (17 ft. lbs.)  | 23 N•m (17 ft. lbs.)  |
| — Bracket                             | —  | —                      | 34 N•m (25 ft. lbs.)  | 34 N•m (25 ft. lbs.)  |
| Caliper — Mounting Bolt               | 48 N•m (35 ft. lbs.)   |                        |                       |                       |
| — Support Plate to Knuckle            | 16 N•m (140 in. lbs.)  |                        |                       |                       |
| Brake Pedal — Bracket to Dash         | 34 N•m (25 ft. lbs.)   | 34 N•m (25 ft. lbs.)   | 17 N•m (150 in. lbs.) | 34 N•m (25 ft. lbs.)  |
| — Bracket to I.P.                     | 34 N•m (25 ft. lbs.)   | 34 N•m (25 ft. lbs.)   | —                     | —                     |
| — Pivot Bolt Nut                      | 34 N•m (25 ft. lbs.)   | 34 N•m (25 ft. lbs.)   | —                     | —                     |
| — Sleeve to Bracket                   | —  | —                      | —                     | 9.5 N•m (85 in. lbs.) |
| — Stoplamp Switch Bracket             | 34 N•m (25 ft. lbs.)   | 34 N•m (25 ft. lbs.)   | 34 N•m (25 ft. lbs.)  | —                     |
| — Push Rod to Pedal                   | —  | —                      | —                     | 34 N•m (25 ft. lbs.)  |
| — Push Rod Adjusting Nut              | —  | —                      | —                     | 30 N•m (22 ft. lbs.)  |
| Parking Brake — to Dash               | 12 N•m (100 in. lbs.)  | 12 N•m (100 in. lbs.)  | 12 N•m (100 in. lbs.) | —                     |
| — to I.P., Kick Panel or Floorpan     | 17 N•m (100 in. lbs.)  | 17 N•m (100 in. lbs.)  | 12 N•m (100 in. lbs.) | 24 N•m (18 ft. lbs.)  |
| — Cable Clips — Screws                | 17 N•m (150 in. lbs.)  | —                      | 12 N•m (100 in. lbs.) | 17 N•m (150 in. lbs.) |
| — Bolts                               | 17 N•m (150 in. lbs.)  | —                      | 24 N•m (18 ft. lbs.)  | 6 N•m (55 in. lbs.)   |
| Propshaft Parking Brake               |  |                        |                       |                       |
| — Adjusting Nut                       | —  | —                      | —                     | 40 N•m (30 ft. lbs.)  |
| — Bracket to Trans.                   | —  | —                      | —                     | 27 N•m (20 ft. lbs.)  |
| — Cable Clip to Frame                 | —  | —                      | —                     | 17 N•m (150 in. lbs.) |
| — Cable Clip to Dash                  | —  | —                      | —                     | 6 N•m (55 in. lbs.)   |
| — Cable Clip to Trans. Brkt.          | —  | —                      | —                     | 27 N•m (20 ft. lbs.)  |
| — Flange Plate                        | —  | —                      | —                     | 40 N•m (30 ft. lbs.)  |
| — Drum                                | —  | —                      | —                     | 110 N•m (80 ft. lbs.) |
| Wheel Cylinder to Flange Plate Bolt   | 5.5 N•m (50 in. lbs.)/20 N•m (180 in. lbs.) on JB5, JB6, JB7 and JB8 |                        |                       |                       |
| Rear Brake Anchor Pin                 | 190 N•m (140 ft. lbs.)/312 N•m (230 ft. lbs.) JB7 and JB8            |                        |                       |                       |
| Front Brake Hose — to Caliper         | 44 N•m (32 ft. lbs.)   |                        |                       |                       |
| — to Frame Nut                        | 7 N•m (58 in. lbs.)  |                        |                       |                       |
| — Bracket Bolt                        | 17 N•m (150 in. lbs.)  | —                      | 17 N•m (150 in. lbs.) | 17 N•m (150 in. lbs.) |
| Rear Brake Hose — to Axle Bracket     | *17 N•m (150 in. lbs.)   | *17 N•m (150 in. lbs.) | 10 N•m (90 in. lbs.)  | 17 N•m (150 in. lbs.) |
| — Bracket to Axle                     | 17 N•m (150 in. lbs.)  | 17 N•m (150 in. lbs.)  | —                     | 17 N•m (150 in. lbs.) |
| Brake Line — Attaching Nuts           | 17 N•m (150 in. lbs.)  |                        |                       |                       |
| — Retaining Clips — Screws            | 17 N•m (150 in. lbs.)  | 17 N•m (150 in. lbs.)  | 12 N•m (100 in. lbs.) | 17 N•m (150 in. lbs.) |
| — Bolts                               | —  | —                      | 17 N•m (150 in. lbs.) | 24 N•m (18 ft. lbs.)  |
| Brake Bleeder Valves                  | 7 N•m (60 in. lbs.)  |                        |                       |                       |
| Hydro-Boost —                         |  |                        |                       |                       |
| — Pedal Rod — P30 (32) Models         | —  | —                      | —                     | 34 N•m (25 ft. lbs.)  |
| — Pedal Rod Boot — P30 (32) Models    | —  | —                      | —                     | 20 N•m (15 ft. lbs.)  |
| — Pivot Lever Rod Retainer            | —  | —                      | —                     | 34 N•m (25 ft. lbs.)  |
| — Pivot Lever Bolt                    | —  | —                      | —                     | 60 N•m (45 ft. lbs.)  |
| — Booster Brackets                    | —  | —                      | —                     | 34 N•m (25 ft. lbs.)  |
| — Booster Brace at Dash or Rad. Supt. | —  | —                      | —                     | 17 N•m (150 in. lbs.) |
| — Power Steering Pump to Booster Line | 34 N•m (25 ft. lbs.)   |                        |                       |                       |
| — Booster to Gear Line                | 34 N•m (25 ft. lbs.)   |                        |                       |                       |
| — Return Line at Booster and Gear     | 34 N•m (25 ft. lbs.)   |                        |                       |                       |
| — Return Line Clamp Screw             | 1.6 N•m (15 in. lbs.)  |                        |                       |                       |
| — Line Clamp to Bracket Screw         | 17 N•m (150 in. lbs.)  |                        |                       |                       |
| — Hose Clamp to Skirt Screw           | 4.6 N•m (40 in. lbs.)  | —                      | —                     | —                     |
| — Line Clamp to Frame Bolt            | 17 N•m (150 in. lbs.)  | —                      | —                     | 17 N•m (150 in. lbs.) |

\*27 N•m (20 ft. lbs.)

\*\*44 N•m (32 ft. lbs.) — Master Cylinder to Booster  
— Master Cylinder or Booster to Dash Reinforcement

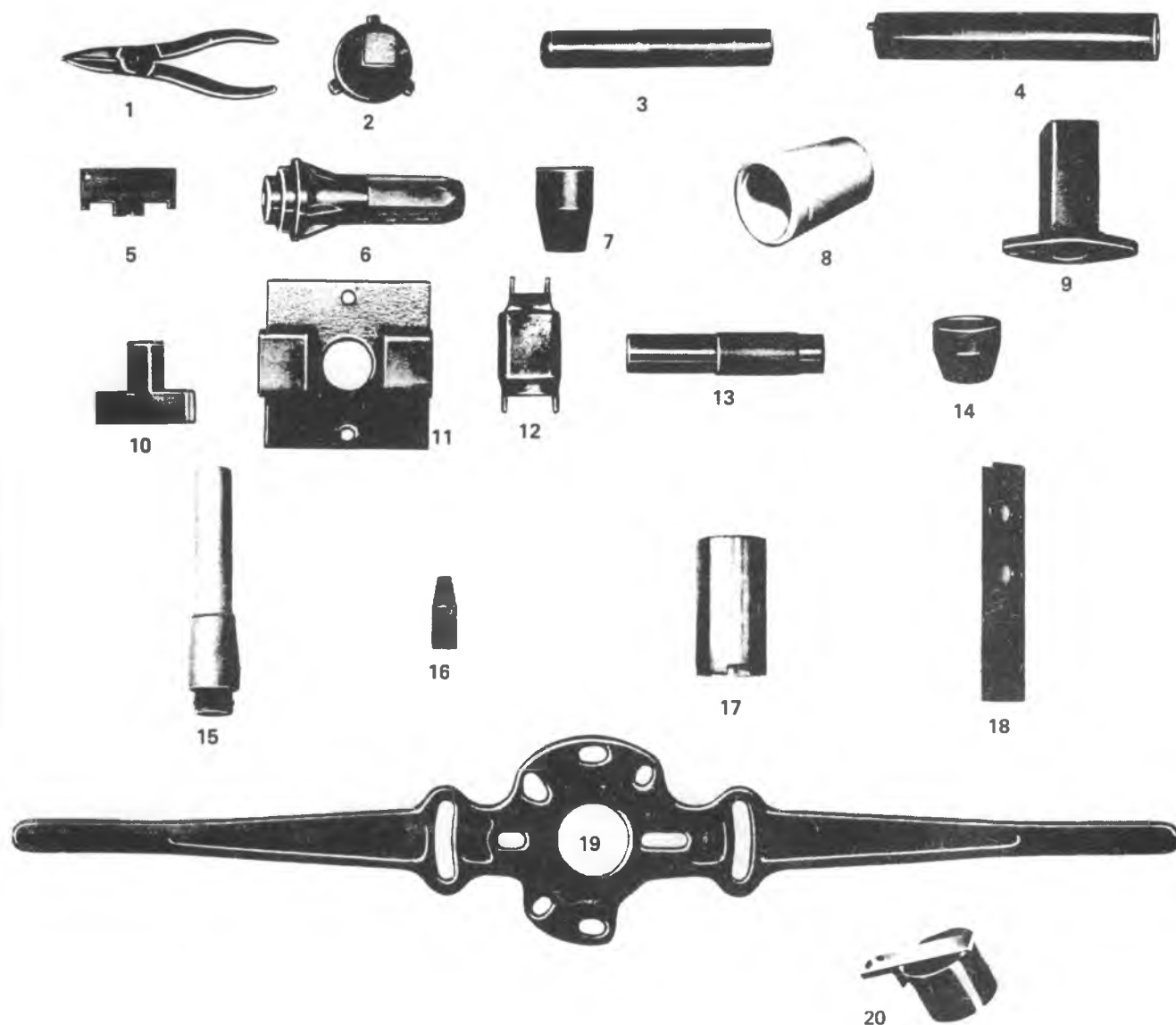

- |   |  |
|---|--|
| 1. J-4880 Snap Ring Pliers                    | 13. J-23175 Control Valve Installer      |
| 2. J-21524 Power Piston Remover and Installer | 14. J-23188 Secondary Bearing Protector  |
| 3. J-21601 Power Brake Retainer and Installer | 15. J-24551 Piston Installers            |
| 4. J-22657 Bushing Retainer Socket            | J-25083                                  |
| 5. J-22647 Height Gauge                       | 16. J-24553 Input Rod Seal Installers    |
| 6. J-22677 Power Cylinder Seal Installer      | J-28485                                  |
| 7. J-22733 Seal Installer and Protector       | J-28497                                  |
| 8. J-28458 Power Piston Seal Protector        | 17. J-24554 Socket                       |
| 9. J-22805 Power Cylinder Holding Fixture     | 18. J-24569 Pedal Push Rod Remover       |
| 10. J-22839 Front Plate Holding Fixture       | 19. J-9504 Power Cylinder Spanner Wrench |
| 11. J-22893 Booster Separating Adapter        | 20. J-26889 Accumulator Compressor       |
| 12. J-23101 Power Piston Holding Tool         |  |



# SECTION 6

## ENGINE

### CONTENTS

|  |      |
|--|------|
| General Information.....                     | 6-1  |
| Engine Performance Diagnosis - Gasoline..... | 6-2  |
| Engine Mechanical Diagnosis - Gasoline.....  | 6-6  |
| Engine Diagnosis - Diesel.....               | 6-9  |
| Engine Cooling.....                          | 6B-1 |
| Engine Fuel.....                             | 6C-1 |
| Engine Electrical.....                       | 6C-1 |
| Emission Controls.....                       | 6E-1 |
| Exhaust Systems.....                         | 6F-1 |

**ALL NEW GENERAL MOTORS VEHICLES ARE CERTIFIED BY THE UNITED STATES ENVIRONMENTAL PROTECTION AGENCY AS CONFORMING TO THE REQUIREMENTS OF THE REGULATIONS FOR THE CONTROL OF AIR POLLUTION FROM NEW MOTOR VEHICLES. THIS CERTIFICATION IS CONTINGENT ON CERTAIN ADJUSTMENTS BEING SET TO FACTORY STANDARDS. IN MOST CASES, THESE ADJUSTMENT POINTS EITHER HAVE BEEN PERMANENTLY SEALED AND/OR MADE INACCESSIBLE TO PREVENT INDISCRIMINATE OR ROUTINE ADJUSTMENT IN THE FIELD. FOR THIS REASON, THE FACTORY PROCEDURE FOR TEMPORARILY REMOVING PLUGS, CAPS, ETC., FOR PURPOSES OF SERVICING THE PRODUCT MUST BE STRICTLY FOLLOWED AND, WHEREVER PRACTICABLE, RETURNED TO THE ORIGINAL INTENT OF THE DESIGN.**

**FOR VEHICLES SOLD IN CANADA AND EQUIPPED WITH NON-CLOSED LOOP ENGINES, ALSO REFER TO THE APPROPRIATE CANADIAN SERVICE MANUAL SUPPLEMENT.**

### GENERAL INFORMATION

#### STATEMENT ON CLEANLINESS AND CARE

An automobile engine is a combination of many machined, honed, polished and lapped surfaces with tolerances that are measured in the ten thousands of an inch. When any internal engine parts are serviced, care and cleanliness are important. A liberal coating of engine oil should be applied to friction areas during assembly to protect and lubricate the surfaces on initial operation. Throughout this section, it should be understood that proper cleaning and protection of machined surfaces and friction areas is part of the repair procedure. This is considered standard shop practice even if not specifically stated.

Whenever valve train components are removed for service, they should be retained in order. At the time of installation, they should be installed in the same locations and with the same mating surfaces as when removed.

Battery cables should be disconnected before any major work is performed on the engine. Failure to disconnect cables may result in damage to wire harness or other electrical parts.

#### GENERAL INFORMATION ON ENGINE SERVICE

THE FOLLOWING INFORMATION ON ENGINE SERVICE SHOULD BE NOTED CAREFULLY, AS IT IS IMPORTANT IN PREVENTING DAMAGE AND IN CONTRIBUTING TO RELIABLE ENGINE PERFORMANCE.

When raising or supporting the engine for any reason, do not use a jack under the oil pan. Due to the small clearance between the oil pan and the oil pump screen, jacking against the oil pan may cause it to be bent against the pump screen resulting in a damaged oil pickup unit.

It should be kept in mind, while working on the engine, that the 12-volt electrical system is capable of damaging short circuits. When performing any work where electrical terminals could possibly be grounded, the ground cable of the battery should be disconnected at the battery.

Any time the carburetor, throttle body injector assembly, or air cleaner is removed, the intake opening should be covered. This will protect against accidental entrance of foreign material which could follow the intake passage into the cylinder and cause extensive damage when the engine is started.

IN THE MECHANICAL PROCEDURES DESCRIBED IN THIS SECTION, GENERALLY NO REFERENCES WILL BE MADE TO THE REMOVAL OF OPTIONAL EQUIPMENT SUCH AS POWER STEERING PUMP, AIR CONDITIONING COMPRESSOR, ETC.

SHOULD IT BECOME NECESSARY TO REMOVE ANY SUCH ITEM TO PERFORM OTHER SERVICE, REFER TO THE APPROPRIATE SECTION OF THIS SERVICE MANUAL FOR SPECIFIC INFORMATION.

#### INTRODUCTION

Engine Performance Diagnosis procedures are guides that will lead to the most probable causes of engine performance complaints. They consider the components of the fuel, ignition, and mechanical systems that could cause a particular complaint, and then outline repairs in a logical sequence.

It is important to determine if the "Check Engine" light is "ON" or has come "ON" for a short interval while driving. If the "Check Engine" light has come "ON," the Computer Command Control System should be checked for stored "Trouble Codes" (see Diagnostic Circuit Check Section 6E) which may indicate the cause for the performance complaint.

The procedures are based on Symptoms that are listed in the Table of Contents.

Each Symptom is defined, and it is vital that the correct one be selected based on the complaints reported or found.

Review the Symptoms and their definition to be sure that only the correct terms are used.

The words used may not be what you are used to in all cases, but because these terms have been used interchangeably for so long, it was necessary to decide on the most common usage and then define them. If the definition is not understood, and the exact Symptom is not used, the Diagnostic procedure will not work.

It is important to keep two facts in mind:

1. The procedures are written to diagnose problems on cars that have "run well at one time" and that time and wear have created the condition.
2. All possible causes cannot be covered, particularly with regard to emission controls. If doing the work prescribed does not correct the complaint, then either the wrong Symptom was used or a more detailed analysis will have to be made.

All of the Symptoms can be caused by worn out or defective parts such as Spark Plugs, Ignition Wiring, etc. If time and/or mileage indicate that parts should be replaced, it is recommended that it be done.

Refer to Section 6E for "Computer Command Control System" diagnosis and service procedures specific to the system and its components.

## SYMPTOM - DEFINITION

1. Intermittent "Check Engine" Light With No Code Stored  
The "check engine" light flashes intermittently during vehicle operation but does not store a diagnosis code.
2. Dieseling  
Engine continues to run after the switch is turned off. It runs unevenly and makes knocking noises.
3. Detonation  
A mild to severe ping, usually worse under acceleration. The engine makes sharp metallic knocks that change with throttle opening. Sounds like popcorn popping.
4. Stalls, Cold or Hot  
The engine quits running. It may be at idle or while driving.
5. Rough Idle, Cold or Hot  
The engine runs unevenly at idle. If bad enough, it may make the car shake.
6. Miss  
Steady pulsation or jerking that follows engine speed, usually more pronounced as engine load increases. Not normally felt above 1500 rpm or 30 mph. The exhaust has a steady spitting sound at idle or low speed.
7. Hesitates  
Momentary lack of response as the accelerator is depressed. Can occur at all car speeds. Usually most severe when first trying to make the car move, as from a stop sign. May cause the engine to stall if severe enough.
8. Surges/Chuggle  
Engine power variation under steady throttle or cruise. Feels like the car speeds up and slows down with no change in the accelerator pedal.
9. Sluggish  
Engine delivers limited power under load or at high speed. Won't accelerate as fast as normal; loses too much speed going up hills, or has less top speed than normal.

10. Spongy  
Less than the anticipated response to increased throttle opening. Little or no increase in speed when the accelerator pedal is pushed down a little to increase cruising speed. Continuing to push the pedal down will finally give an increase in speed.
11. Poor Fuel Mileage  
Self describing.
12. Cuts Out  
The engine exhibits a significant or total temporary loss of power at sharp, irregular intervals. This may occur repeatedly or intermittently and is usually worse under heavy acceleration.
13. Hard Start - Cold  
The engine requires excessive cranking or fails to start cold.
14. Hard Start - Hot  
The engine requires excessive cranking or fails to start hot.
15. After Fire  
Popping sound in the exhaust system on deceleration.
16. Back-Fire  
Muffled popping sound in air induction system on acceleration.

## ENGINE PERFORMANCE DIAGNOSIS

**NOTICE:** Before checking any system controlled by the Computer Command Control system, the "Diagnostic Circuit Check," Section 6E-1 and 6E-2, must be performed or misdiagnosis may occur. If the complaint involves the "Check Engine" light, go directly to the "Diagnostic Circuit Check," Section 6E-1 and 6E-2.

1. Intermittent "Check Engine" Light With No Code Stored
  - a. Refer to Driver Complaint Sheet, Section 6E1.
2. Dieseling
  - a. Make visual checks of the following for sticking.
    - (1) Carburetor, choke, and throttle linkage.
    - (2) Fast idle cam, See cleaning, inspection, and adjustment of carburetor, Section 6C.
    - (3) Check cruise control adjustment where applicable.
  - b. Check and if necessary reset ignition timing and idle speed settings. Refer to emission label.
  - c. Remove carbon with top engine cleaner. Follow instructions on can.
  - d. Check for engine overheating.
    - (1) Low coolant.
    - (2) Loose fan belt.
    - (3) Restricted air flow, etc.
    - (4) Inoperative electric cooling fan motor or fan clutch.
  - e. Check idle speed control if applicable.
  - f. See "Computer Command Control" diagnosis, "Diagnostic Circuit Check " - Section 6E-1.
3. Detonation
  - a. Check for obvious overheating problems.
    - (1) Low coolant.
    - (2) Loose fan belt.
    - (3) Restricted air flow, etc.

- (4) Inoperative electric cooling fan motor.
- b. Check ignition timing per emission control information label.
  - c. See Computer Command Control Diagnosis "Diagnostic Circuit Check," - Section 6E1.
  - d. Check "EST or ESC" diagnosis, see Section 6E-1.
  - e. Perform EGR functional check see Section 6E-1.
  - f. Check MAP and Baro or vacuum sensor output and proper connections, Section 6E-1.
  - g. Check TPS enrichment operation, if applicable, Section 6E-1.
  - h. Remove carbon with top engine cleaner. Follow instructions on can.
4. Stalls or Rough Idle - Cold
- a. Check air cleaner damper door operation using procedure in 6E-1.
  - b. Visually check the following:
    - (1) Hot air tube to air cleaner connection and condition of hot air stove.
    - (2) Air leaks at carburetor, mounting and intake manifold.
    - (3) Ignition wires for cracking, hardness and proper connections.  
Repair or replace as necessary.
  - c. Check the following for sticking:
    - (1) Carburetor choke, and throttle linkage.
    - (2) Fast idle cam and fast idle speed setting.
    - (3) Carburetor float.  
See Cleaning, Inspection and Adjustment of Carburetor, Section 6C.
  - d. With engine running, visually check vacuum break linkage for movement while removing and reinstalling vacuum hose. If the linkage does not move and vacuum is at hose (check for binding linkage), replace vacuum break assembly.
  - e. With engine off, check all choke adjustments, including vacuum break and TVS if used. See Section 6C.
  - f. Check engine timing and idle speed. See Emission Control Information Label.
  - g. Check carburetor for flooding and correct float level.
  - h. See "Computer Command Control" diagnosis, "Diagnostic Circuit Check" - Section 6E-1.
  - i. Check E.G.R., see Section 6E-1 for functional tests, cleaning, and/or replacement.
  - j. Check E.F.E. valve or electric heater, if applicable. See Section 6E-1.
  - k. Check ISC or IAC operation, if applicable - Section 6E.
  - l. Check closed loop Emission Control Section 6E.
5. Stalls or Rough Idle - Hot
- a. Check air cleaner damper door operation using procedure in 6E-1.
  - b. Visually check the following:
    - (1) Vacuum hoses for splits, kinks and proper connections. See hose routing Schematic, Vehicle Emission Control Information Label.
    - (2) Air leaks at carburetor, mounting and intake manifold.
    - (3) Ignition wires for cracking, hardness and proper connections. Repair or replace as necessary.
    - (4) Check idle solenoid, if applicable; replace as necessary. See idle solenoid Section 6E-1.
    - (5) Check carburetor for flooding and correct float level.
  - c. Check engine timing and idle speed. See emission control information label.
  - d. Check P.C.V. valve for proper operation by placing finger over inlet hole in valve end several times. Valve should snap back. If not, replace valve.
  - e. See Computer Command Control Diagnosis, "Diagnostic Circuit Check" - Section 6E-1.
  - f. Check EGR operation - Section 6E-1.
  - g. Check idle speed control (ISC) or idle air control (IAC), if applicable - Section 6E-1.
  - h. Remove carbon with top engine cleaner. Follow instructions on can. If idle is still rough, run a cylinder compression check.
  - i. Check closed loop emission control Section 6E.
6. Miss
- a. Visually check the following:
    - (1) Vacuum hoses for splits, kinks and proper connections. See hose routing schematic, Vehicle Emission Control Information Label.
    - (2) Air leaks at carburetor mounting and intake manifold.
    - (3) Ignition wires for cracking, hardness and proper connections. Repair or replace as necessary.
  - b. Disconnect air cleaner and E.G.R. vacuum hoses and cap both vacuum sources.
  - c. Remove one spark plug wire at a time with insulated pliers. If there is an rpm drop on all cylinders, go to rough idle (hot) diagnosis charts.
  - d. If there is no rpm drop on one or more cylinders (see Section 6D Intermittent Operation or Miss), remove spark plug(s) and check for:
    - (1) Cracks
    - (2) Wear
    - (3) Improper gap
    - (4) Burned Electrodes
    - (5) Heavy Deposits
  - e. Check spark plug wires by connecting ohmmeter to ends of each wire in question. If meter reads over 50,000 ohms, replace wire(s).
  - f. Visually check distributor cap and rotor for moisture, dust, cracks, burns, etc. Clean and/or repair as necessary.
  - g. Perform compression check on questionable cylinder(s). If compression is low, repair as necessary.
  - h. Remove rocker covers. Check for bent push rods, worn rocker arms, broken valve springs, worn cam shaft lobes. Repair as necessary.
  - i. Check closed loop emission control Section 6E.
7. Hesitates
- a. Visually check the following:
    - (1) Vacuum hoses for splits, kinks and proper connections. See tune-up label for proper routing.
    - (2) Air leaks at carburetor or throttle body assembly mounting and intake manifold.
    - (3) Check ignition wires for cracking, hardness and proper connections. Repair and replace as necessary.
  - b. Note: Cold Engine Only- Check the following for sticking or faulty operation.
    - (1) Carburetor choke, including vacuum break, and throttle linkage, check TVS if used.
    - (2) Fast idle cam.  
See Cleaning, Inspection and Adjustment of Carburetor, Section 6C.

- c. Check carburetor accelerator pump operation. With air cleaner removed and engine off, hold choke valve open and look for gas squirt in carburetor bore while moving throttle.  
If weak or no pump squirt, remove carburetor air horn and repair pump system as necessary. See Air Horn Removal, Cleaning and Inspection, Section 6C for proper procedures. Check float level adjustment before replacing air horn and pump rod adjustment after assembly. See Float Adjustment, Section 6C.
  - d. Check float level.
  - e. Check thermostatic air cleaner damper door operation using procedure in 6E-1.
  - f. See Computer Command Control Diagnosis, Diagnostic Circuit Check, Section 6E-1.
  - g. Check ignition timing and idle speed per emission control information label.
  - h. Check TPS adjustment if applicable see 6C.
  - i. Check closed loop emission control section 6E.
8. Surges/Chuggle
- a. Check thermostatic air cleaner damper door operation using procedures in 6E-1.
  - b. Visually check the following:
    - (1) Vacuum hoses for splits, kinks and proper connections. See hose routing Schematic, Vehicle Emission Control Information Label.
    - (2) Air leaks at carburetor mounting and intake manifold.
    - (3) Ignition wires for cracking, hardness and proper connections. Repair or replace.
  - c. See "Computer Command Control" diagnosis, "Diagnostic Circuit Check" - Section 6E-1.
  - d. Check ignition timing per emission control information label. Check EST operation if applicable.
  - e. Check park/neutral switch adjustment.
  - f. Check carburetor fuel inlet filter. Replace if dirty or plugged.
  - g. Check mixture control solenoid travel. Section 6C1 or 6C2.
  - h. Test fuel pump by connecting hose from carburetor fuel feed line to a suitable container. Start engine and let idle for 15 seconds. Mechanical or electrical pump should supply 1/2 pint or more. If not, go to step i. If OK, go to step l.
  - i. To check mechanical fuel pump connect a vacuum gage. Crank or run engine until maximum vacuum is reached. If less than 12 inches, replace pump. If vacuum reading is 12 inches or more, go to step h.
  - j. Check fuel lines and hoses for splits, leaks or kinks by disconnecting each section of line and connect vacuum gage. Crank or run engine until vacuum gage peaks. Vacuum should be at least 12 inches. If less, repair or replace defective line or hose.
  - k. If fuel lines and pump check OK, remove tank unit, replace strainer and clean fuel tank, if necessary.
  - l. Remove spark plugs, Check for cracks, wear, improper gap, burned electrodes, heavy deposits. Repair or replace as necessary.
  - m. "Non-Est" check ignition timing per emission control information label. To check mechanical advance, observe timing marks. It should advance as throttle is opened and return to mark as throttle is closed.
9. Sluggish or Spongy
- a. Remove air cleaner and check air filter for dirt or being plugged. Replace as necessary.
  - b. Check thermostatic air cleaner damper door operation using procedures in Section 6E-1.
  - c. Remove air cleaner and check for full throttle valve opening in carburetor by depressing accelerator pedal to floor; also check for full choke valve opening and free operating air valve (if equipped). Repair as necessary. See Carburetor Cleaning and Inspection, Section 6C.
  - d. See "Computer Command Control" diagnosis, "Diagnostic Circuit Check" - Section 6E-1.
  - e. Check ignition timing per emission label.
  - f. Check EGR operation - Section 6E-1.
  - g. Check EST operation - Section 6E-1.
  - h. Check MAP and baro sensor or vacuum sensor output as applicable.
  - i. Remove spark plugs. Check for cracks, wear, improper gap, burned electrodes, heavy deposits. Repair or replace as necessary.
  - j. Non-Indexed timing belt or chain.
  - k. Excessive brake drag.
  - l. E.F.E. valve malfunctioning.
  - m. "Non-Est" check ignition timing per emission control information label. To check mechanical advance, observe timing marks. It should advance as throttle is opened and return to mark as throttle is closed.
  - n. "Non-Est" with engine off, remove vacuum hose from distributor vacuum advance. Connect vacuum pump and apply 15" vacuum. Vacuum should hold steady for 15 seconds. If vacuum drops, replace vacuum advance unit.
10. Poor Gasoline Mileage
- a. Check thermostatic air cleaner operation using procedures in Section 6E-1.
  - b. Visually check the following:
    - (1) Vacuum hoses for splits, kinks and proper connections. See hose routing Schematic, Vehicle Emission Control Information Label.
    - (2) Air leaks at carburetor mounting and intake manifold.
    - (3) Ignition wires for cracking, hardness and proper connections. Repair or replace.
  - c. Check carburetor choke linkage and settings. Clean and repair as necessary. See Carburetor Choke Adjustments, Cleaning and Inspection, Section 6C.
  - d. Check ignition timing per emission control information label.
  - e. Check carburetor for flooding and proper float level.
  - f. See "Computer Command Control" diagnosis, "Diagnostic Circuit Check" - Section 6E-1.
  - g. Check EST operation and ESC operation if applicable - Section 6E-1.
  - h. Check MAP and baro or vacuum sensor output.
  - i. Remove spark plugs, check for cracks, wear, improper gap, burned electrodes, heavy deposits. Repair or replace as necessary.



- j. Suggest owner fill tank and recheck mileage.
  - k. Torque converter clutch.
  - l. "Non-Est" check ignition timing per emission control information label. To check mechanical advance, observe timing marks. It should advance as throttle is opened and return to mark as throttle is closed.
  - m. "Non-Est" with engine off, remove vacuum hose from distributor vacuum advance. Connect vacuum pump and apply 15" vacuum. Vacuum should hold steady for 15 seconds. If vacuum drops, replace vacuum advance unit.
  - n. Incorrect tire pressure.
  - o. Excessive brace drag.
  - p. Check carburetor cleaning and inspection in Section 6C.
  - q. Deceleration valve inoperative.
11. Cuts Out
- a. Check ignition wires, boots, cap and coil for:
    - (1) Damage
    - (2) Deterioration
    - (3) Loose connections
    - (4) Carbon tracking clean, tighten and/or replace parts as necessary.
  - b. See "Computer Command Control" diagnosis, "Diagnostic Circuit Check" - Section 6E-1.
  - c. Check ignition system "Intermittent Operation or Miss" - Section 6D. Check distributor for:
    - (1) Worn shaft
    - (2) Bare or shorted wires. Repair or replace defective parts as necessary.
    - (3) Ignition coil for intermittent primary connections (or ground or integral coil units).
  - d. Remove spark plugs. Check for cracks, wear, improper gap, burned electrodes, heavy deposits. Repair or replace as necessary.
  - e. Check carburetor fuel inlet filter. Replace if dirty or plugged.
  - f. Test fuel pump by connecting hose from carburetor fuel feed line to a suitable container. Start engine and let idle for 15 seconds. Mechanical pump should supply 1/2 pint or more. If not, go to step g.
  - g. To check mechanical fuel pump, disconnect inlet hose at pump and connect a vacuum gage. Crank or run engine until maximum vacuum is reached. If less than 12 inches, replace pump. If vacuum reading is 12 inches or more, go to step h. For electric pump 17.9 kpa (4.2 inches of mercury).
  - h. Check fuel lines and hoses for splits, leaks or kinks by disconnecting each section of line and connecting a vacuum gage. Crank or run engine until vacuum gage peaks. Vacuum should be at least 12 inches. If less, repair or replace defective line or hose as necessary.
  - i. If fuel pump and fuel lines check OK, remove tank unit, replace strainer and clean fuel tank, if necessary.
  - j. See carburetor cleaning and adjustment, Section 6C.
12. Hard Starting - Cold (Engine Cranks OK)
- a. If engine won't run, see Computer Command Control "Diagnostic Circuit Check" Section 6-E and "Cranks But Won't Run" Chart, Section 6D.
  - b. Visually check the following:
    - (1) Vacuum hoses for splits, kinks and proper connections. See hose routing charts on tune-up label.
    - (2) Air leaks at carburetor mounting and intake manifold.
    - (3) Ignition wires for cracking, hardness, proper connections, and carbon tracking. Repair or replace as necessary.
  - c. Check the following:
    - (1) Choke for sticking.
    - (2) Air leaks at carburetor mounting and intake manifold.
    - (3) Ignition wires for cracking, hardness, proper connections, and carbon tracking. Repair or replace as necessary.
    - (4) Check choke and vacuum break operation and adjustment.
- c. Check the following:
- (1) Choke, throttle linkage and fast idle cam for sticking.
  - (2) Carburetor flooding.  
Clean and repair as necessary. If repairs are necessary, see Carburetor, Cleaning and Inspection, Section 6C.
- d. See "Computer Command Control" diagnosis, "Diagnostic Circuit Check" - Section 6E-1.
- e. Check ignition timing per emission control information label.
- f. Check EST operation - Section 6E-1.
- g. Check ignition system - Section 6D. Check distributor for:
  - (1) Worn shaft.
  - (2) Bare and shorted wires.
  - (3) Repair or replace as necessary.
  - (4) Pickup coil resistance and connections.
- h. Remove spark plugs. Check for cracks, wear, improper gap, burned electrodes, heavy deposits. Repair or replace as necessary.
- i. Test fuel pump by connecting hose from carburetor fuel feed line to a suitable container. Start engine and let idle for 15 seconds. Pump should supply 1/2 pint or more. If more than 1/2 pint, check filter in carburetor. Replace if necessary. If less than 1/2 pint, for mechanical pump go to step j.
- j. Disconnect inlet hose at pump and connect a vacuum gage. Crank or run engine until maximum vacuum is reached. If less than 12 inches, replace pump. If more than 12 inches, go to step k.
- k. Check fuel lines and hoses for splits, leaks or kinks by disconnecting each section of line and connect vacuum gage. Crank or run engine until vacuum gage peaks. Vacuum should be at least 12 inches. If less, repair or replace defective line or hose.
- l. If fuel lines and pump check OK, remove tank unit, replace strainer and clean fuel tank, if necessary.
- m. Broken or worn timing belt.
- n. "Non-Est" check ignition timing per emission control information label. To check mechanical advance, observe timing marks. It should advance as throttle is opened and return to mark as throttle is closed.
13. Hard Starting - Hot (Engine cranks OK)
- a. If engine won't run, see Computer Command Control "Diagnostic Circuit Check," Section 6E and "Cranks But Won't Run" Chart, Section 6D.
  - b. Visually check the following:
    - (1) Vacuum hoses for splits, kinks and proper connections. See hose routing Schematic, Vehicle Emission Control Information Label.
    - (2) Air leaks at carburetor mounting and intake manifold.
    - (3) Ignition wires for cracking, hardness, proper connections, and carbon tracking. Repair or replace as necessary.
  - c. Check the following:
    - (1) Choke for sticking.

- (2) Carburetor flooding.  
Clean and repair as necessary. If repairs are necessary, see Carburetor, Cleaning and Inspection, Section 6C.
- d. See "Computer Command Control" diagnosis, "Diagnostic Circuit Check" - Section 6E-1.
- e. Check ignition system, Section 6D. Check distributor for:
- (1) Worn shaft.
  - (2) Bare and shorted wires.
  - (3) Faulty pick up coil or connections, module, ignition coil, and condenser. Repair or replace as necessary.
- f. Remove spark plugs. Check for cracks, wear, improper gap, burned electrodes, heavy deposits. Repair or replace as necessary.
- g. Also check steps i, j, k, l - Hard Starting - Cold. Emission Non-Compliance, see Section 6E.
- h. "Non-Est" check ignition timing per emission control information label. To check mechanical advance, observe timing marks. It should advance as throttle is opened and return to mark as throttle is closed.

## ENGINE MECHANICAL DIAGNOSIS

The following diagnostic information covers common problems and possible causes. When the proper diagnosis is made, the problem should be corrected by adjustment, repair or

part replacement as required. Refer to the appropriate section of the manual for these procedures.

| CONDITION          | POSSIBLE CAUSE  | CORRECTION  |
|--------------------|---|---|
| Excessive Oil Loss | a. External oil leaks.  | 1. Tighten bolts and/or replace gaskets and seals as necessary.                                   |
|                    | b. Improper reading of dipstick.  | 1. Check oil with car on a level surface and allow adequate drain down time.                      |
|                    | c. Improper oil viscosity.  | 1. Use recommended S.A.E. viscosity for prevailing temperatures.                                  |
|                    | d. Continuous high speed driving and/or severe usage such as trailer hauling. | 1. Continuous high speed operation and/or severe usage will normally cause decreased oil mileage. |
|                    | e. Crankcase ventilation or P.C.V. system malfunctioning.                     | 1. Service as necessary.  |
|                    | f. Valve guides and/or valve stem seals worn, or seals omitted.               | 1. Ream guides and install oversize service valves and/or new valve stem seals.                   |
|                    | g. Piston rings not seated, broken or worn.                                   | 1. Allow adequate time for rings to seat.<br>2. Replace broken or worn rings as necessary.        |
|                    | h. Piston improperly installed or misfitted.                                  | 1. Replace piston or repair as necessary.   |
| Low Oil Pressure   | a. Slow idle speed.   | 1. Set idle speed to specs.   |
|                    | b. Incorrect or malfunctioning oil pressure switch.                           | 1. Replace with proper switch.  |
|                    | c. Incorrect or   | 1. Replace with proper gage.  |

|                   |  |  |
|-------------------|--|--|
|                   | malfunctioning oil pressure gage.          |  |
|                   | d. Improper oil viscosity or diluted oil.  | <ol style="list-style-type: none"> <li>1. Install oil of proper viscosity for expected temperature.</li> <li>2. Install new oil if diluted with moisture or unburned fuel mixtures.</li> </ol> |
|                   | e. Oil pump worn or dirty.                 | <ol style="list-style-type: none"> <li>1. Clean pump and replace worn parts as necessary.</li> </ol>   |
|                   | f. Plugged oil filter.                     | <ol style="list-style-type: none"> <li>1. Replace filter and oil.</li> </ol>   |
|                   | g. Oil pickup screen loose or plugged.     | <ol style="list-style-type: none"> <li>1. Clean or replace screen as necessary.</li> </ol>   |
|                   | h. Hole in oil pickup tube.                | <ol style="list-style-type: none"> <li>1. Replace tube.</li> </ol>   |
|                   | i. Excessive bearing clearance.            | <ol style="list-style-type: none"> <li>1. Replace as necessary.</li> </ol>   |
|                   | j. Cracked, porous or plugged oil galleys. | <ol style="list-style-type: none"> <li>1. Repair or replace block.</li> </ol>  |
|                   | k. Galley plugs missing or mis-installed.  | <ol style="list-style-type: none"> <li>1. Install plugs or repair as necessary.</li> </ol>   |
| Valve Train Noise | a. Low oil pressure.                       | <ol style="list-style-type: none"> <li>1. Repair as necessary. (See diagnosis for low oil pressure.)</li> </ol>  |
|                   | b. Loose rocker arm attachments.           | <ol style="list-style-type: none"> <li>1. Inspect and repair as necessary.</li> </ol>  |
|                   | c. Worn rocker arm and/or pushrod.         | <ol style="list-style-type: none"> <li>1. Replace as necessary.</li> </ol>   |
|                   | d. Broken valve spring.                    | <ol style="list-style-type: none"> <li>1. Replace spring.</li> </ol>   |
|                   | e. Sticking valves.                        | <ol style="list-style-type: none"> <li>1. Free valves.</li> </ol>  |
|                   | f. Lifters worn, dirty or defective.       | <ol style="list-style-type: none"> <li>1. Clean, inspect, test and replace as necessary.</li> </ol>  |
|                   | g. Camshaft worn or poor machining.        | <ol style="list-style-type: none"> <li>1. Replace camshaft.</li> </ol>   |
|                   | h. Worn valve guides.                      | <ol style="list-style-type: none"> <li>1. Repair as necessary.</li> </ol>  |

## ENGINE KNOCK DIAGNOSIS

| CONDITION   | POSSIBLE CAUSE   | CORRECTION   |
|---|--|--|
| Engine knocks cold and continues for two to three minutes. Knock increases with torque. | <ol style="list-style-type: none"> <li>a. EFE equipped engines may have valve knock.</li> <li>b. Flywheel contacting splash shield.</li> <li>c. Loose or broken balancer or drive</li> </ol> | <ol style="list-style-type: none"> <li>1. Replace EFE valve.</li> <li>1. Reposition splash shield.</li> <li>1. Tighten or replace as necessary.</li> </ol> |

Engine has heavy knock hot with torque applied.

- pulleys.
  - d. Excessive piston to bore clearance.<sup>1</sup>
  - e. Bent Connecting rod.
- 1. Replace piston.
  - 1. Replace bent connecting rod.
- a. Broken balancer or pulley hub.
  - b. Loose torque converter bolts.
  - c. Accessory belts too tight or nicked.
  - d. Exhaust system grounded.
  - e. Flywheel cracked or loose rivets on flywheel.
  - f. Excessive main bearing clearance.
  - g. Excessive rod bearing clearance.
- 1. Replace parts as necessary.
  - 1. Tighten bolts.
  - 1. Replace and/or tension to specs as necessary.
  - 1. Reposition as necessary.
  - 1. Replace flywheel.
  - 1. Replace as necessary.
  - 1. Replace as necessary.

Engine has light knock hot in light load conditions.

- a. Detonation or spark knock.
  - b. Loose torque converter bolts.
  - c. Exhaust leak at manifold.
  - d. Excessive rod bearing clearance.
- 1. EST or ESC (See Section 6D or 6E) Check engine timing and fuel quality.
  - 1. Tighten bolts.
  - 1. Tighten bolts and/or replace gasket.
  - 1. Replace bearings as necessary.

Engine knocks on initial start up but only lasts a few seconds.

- a. Fuel pump.
  - b. Improper oil viscosity.
  - c. Hydraulic lifter bleed down.<sup>2</sup>
  - d. Excessive crankshaft end clearance.
  - e. Excessive main bearing clearance.
- 1. Replace pump.
  - 1. Install proper oil viscosity for expected temperatures.
  - 1. Clean, test and replace as necessary.
  - 1. Replace crankshaft thrust bearing.
  - 1. Replace worn parts.

Engine knocks at idle hot.

- a. Loose or worn drive belts.
  - b. Compressor or generator bearing.
  - c. Fuel pump.
  - d. Valve train.
  - e. Improper oil viscosity.
  - f. Excessive piston pin clearance.
  - g. Connecting rod alignment.
  - h. Insufficient piston to bore clearance.
  - i. Loose crankshaft balancer.
- 1. Tension and/or replace as necessary.
  - 1. Replace as necessary.
  - 1. Replace pump.
  - 1. Replace parts as necessary.
  - 1. Install proper viscosity oil for expected temperature.
  - 1. Ream and install oversize pins.
  - 1. Check and replace rods as necessary.
  - 1. Hone and fit new piston.
  - 1. Torque any or replace worn parts.

<sup>1</sup>Cold engine piston knock usually disappears when the cylinder is grounded out. Cold engine piston knock which disappears in 1.5 minutes should be considered acceptable.

<sup>2</sup>When the engine is stopped, some valves will be open. Spring pressure against lifters will tend to bleed lifter down. Attempts to repair should be made only if the problem is consistent and appears each time engine is started.

## DIESEL ENGINE DIAGNOSIS

Diesel Engine Mechanical Diagnosis such as noisy lifters, rod bearings, main bearings, valves, rings and pistons is the same as for a gasoline engine. This

diagnosis covers only those conditions that are different for the diesel engine.

| CONDITION   | POSSIBLE CAUSE  | CORRECTION   |
|---|---|--|
| Engine Will Not Crank   | <ul style="list-style-type: none"> <li>a. Loose or Corroded Battery Cables</li> <li>b. Discharged Batteries</li> <li>c. Starter Inoperative</li> </ul>  | <ul style="list-style-type: none"> <li>1. Check connections at batteries, engine block and starter solenoid.</li> <li>1. Check generator output and generator belt adjustment.</li> <li>1. Check voltage to starter and starter solenoid. If OK, remove starter for repair. (Use diagnostic connector terminals shown on circuit drawing in ELECTRICAL DIAGNOSIS.)</li> </ul>  |
| Engine Cranks Slowly-Will Not Start (Minimum Engine Cranking Speed-100 RMP COLD, 240 RPM HOT) | <ul style="list-style-type: none"> <li>a. Battery Cable Connections Loose or Corroded</li> <li>b. Batteries Undercharged</li> <li>c. Wrong Engine oil</li> </ul>  | <ul style="list-style-type: none"> <li>1. Check connections at batteries, batteries, engine block and starter.</li> <li>1. Check charging system.</li> <li>1. Drain and refill with oil of recommended viscosity.</li> </ul>   |
| Engine Cranks Normally-Will Not Start   | <ul style="list-style-type: none"> <li>a. Incorrect Starting procedure</li> <li>b. Glow Plugs Inoperative</li> <li>c. Glow Plug Control System Inoperative.</li> <li>d. No Fuel Into Cylinders</li> </ul> | <ul style="list-style-type: none"> <li>1. Use recommended starting procedure.</li> <li>1. Refer to ELECTRICAL DIAGNOSIS.</li> <li>1. Refer to ELECTRICAL DIAGNOSIS.</li> <li>1. Remove any one glow plug. Depress the throttle part way and crank the engine for 5 seconds. If no fuel vapors come out of the glow plug hole, go to step e. If fuel vapors are noticed remove the remainder of the glow plugs and see if fuel vapors come out of each hole when the engine is cranked. If fuel comes out of one glow plug hole only clean and test the injection nozzle in that cylinder. Crank the engine and check to see that fuel vapors are coming out of all glow plug holes. If fuel is coming from each cylinder,</li> </ul> |

e. Plugged Fuel Return System

- go to step k.
1. Disconnect fuel return line at injection pump and route hose to a metal container. Connect a hose to the injection pump connection, route it to the metal container. Crank the engine. If it starts and runs, correct restriction in fuel return lines.

If it does not start, remove the ball check connector from the top of the injection pump and make sure that it is not plugged.

f. No Fuel To Injection Pump

1. Loosen the line coming out of the filter. Crank the engine, the fuel should spray out of the fitting, use care to direct fuel away from sources of ignition. If fuel sprays from the fitting go to step j.

g. Restricted Fuel Filter

1. Loosen the line going to the filter. If fuel sprays from the fitting, the filter is plugged and should be replaced. Use care to direct the fuel away from sources of ignition.

h. Fuel Pump Inoperative

1. Remove inlet hose to fuel pump. Connect a hose to the pump from a separate container that contains fuel. Loosen the line going to the filter. If fuel does not spray from the fitting, replace the pump. Use care to direct the fuel away from source of ignition.

i. Restricted Fuel Tank Filter

1. Remove fuel tank and check filter. (Filter for diesel fuel is blue.)

j. No Voltage To Fuel Solenoid

1. Connect a voltmeter to the wire at the injection pump solenoid and ground. The voltage should be a minimum of 9 volts. If there is inadequate voltage, refer to the **ELECTRICAL DIAGNOSIS** for more information.

k. Incorrect or Contaminated Fuel

Flush fuel system and install correct fuel.

l. Pump Timing Incorrect

Make certain that pump timing mark is aligned with mark on front cover.

Engine Starts But  
Will Not Continue  
To Run At Idle

- |  |   |
|--|---|
| m. Low Compression                           | 1. Check compression to determine cause.  |
| n. Injection Pump Malfunction                | 1. Remove injection pump for repair.  |
| a. Slow Idle Incorrectly Adjusted            | 1. Adjust idle screw to specification.  |
| b. Fast Idle Solenoid Inoperative            | 1. With engine cold, start engine; solenoid should move to hold injection pump lever in "fast idle position." If solenoid does not move, refer to ELECTRICAL DIAGNOSIS.   |
| c. Restricted Fuel Return System             | 1. Disconnect fuel return line at injection pump and route hose to a metal container. Connect a hose to the injection pump connection; route it to the metal container. Crank the engine and allow it to idle. If engine idles normally, correct restriction in fuel return lines. If engine does not idle normally, remove the return line check valve fitting from the top of the pump and make sure it is not plugged. |
| d. Glow Plugs Turn Off Too Soon              | 1. Refer to ELECTRICAL DIAGNOSIS.   |
| e. Pump Timing Incorrect                     | 1. Make certain that timing mark on injection pump is aligned with mark on front cover.   |
| f. Limited Fuel To Injection Pump            | 1. Test the engine fuel pump; check fuel lines. Replace or repair as necessary.   |
| g. Incorrect or Contaminated Fuel            | 1. Flush fuel system and install correct fuel.  |
| h. Low Compression                           | 1. Check compression to determine cause.  |
| i. Fuel Solenoid Closes In Run Position      | 1. Ignition switch out of adjustment. If OK, refer to ELECTRICAL DIAGNOSIS.   |
| j. Injection Pump Malfunction.               | 1. Remove injection pump for repair.  |
| a. Torque converter clutch engages too soon. | 1. See Section 7A, "Torque Converter Clutch Diagnosis."   |
| b. Timing retarded                           | 1. Be sure timing mark on injection pump is aligned with mark on front cover.   |

Excessive surge at light throttle, under load.  
NOTE: If engine has a rough idle,

Engine Cold Starts and Idle Rough WITH Excessive Noise and/or Smoke, But Clears Up After Warm-Up

- c. Clogged Fuel Filter
  - 1. Check fuel pump pressure on inlet and outlet sides of filter.
- d. Injection Line Volume Too Low.
  - 1. Replaced affected line(s).
- a. Incorrect starting procedure.
  - 1. Advise operator on correct starting procedure.
- b. Injection Pump Timing Incorrect
  - 1. Be sure timing mark on injection pump is aligned with mark on front cover.

- c. Insufficient Engine Break-In Time
  - 1. Break-in engine 2000 or more miles.
- d. Air in System
  - 1. Install a section of clear plastic tubing on the fuel return fitting from the engine. Evidence of bubbles in fuel when cranking or running indicates the presence of an air leak in the suction fuel line. Locate and correct.
  - 1. Loosen injection line at nozzle. If no R.P.M. drop remove and test. Replace as necessary.
- e. Nozzle(s) Malfunction
  - 1. Replace faulty glow plug.
- f. In-Op Glow Plug
  - 1. Replace filter.

Engine Misfires Above Idle But Idles Correctly

- a. Plugged Fuel Filter
  - 1. Replace filter.
- b. Incorrect Injection Pump Timing
  - 1. Align timing mark on injection pump with mark on front cover.

- c. Incorrect or Contaminated Fuel
  - 1. Flush fuel system and install correct fuel.

Engine Will Not Return To Idle

- a. External Linkage Binding Or Misadjusted
  - 1. Free up linkage. Adjust or replace as required.
- b. Fast Idle Malfunction
  - 1. Check fast idle adjustment.
- c. Internal Injection Pump Malfunction
  - 1. Remove injection pump for repair.

Fuel Leaks On Ground-No Engine Malfunction

- a. Loose or Broken Fuel Line or Connection
  - 1. Examine complete fuel system, including tank, lines, and injection lines. Determine source and cause of leak and repair.
- b. Injection Pump Internal Seal Leak
  - 1. Remove injection pump for repair.



Noticeable Loss  
Of Power

- |  |  |
|--|--|
| a. Restricted Air Intake                                   | 1. Check air cleaner element.  |
| b. EGR Malfunction   | 1. Refer to Section 6E.  |
| c. Restricted or Damaged Exhaust System                    | 1. Check system and replace as necessary.  |
| d. Plugged Fuel Filter                                     | 1. Replace filter.   |
| e. Stuck Advance Piston                                    | 1. Increased power loss above 1500 RPM. Remove pump.   |
| f. Air Leak On Suction Side of Fuel Pump                   | 1. Disconnect at pump, pressurize and check for leaks.   |
| g. Plugged Fuel Tank Vacuum Vent In Fuel Cap               | 1. Remove fuel cap. If loud "hissing" noise is heard, vacuum vent in fuel cap is plugged. Replace cap. (Slight hissing sound is normal.)     |
| h. Restricted Fuel Supply From Fuel Tank To Injection Pump | 1. Examine fuel supply system to determine cause of restriction. Repair as required.   |
| i. Restricted Fuel Tank Filter                             | 1. Remove fuel tank and check filter. (Filter for diesel fuel is blue.)  |
| j. Pinched or Otherwise Restricted Return System           | 1. Examine system for restriction and correct as required.   |
| k. Incorrect or Contaminated Fuel                          | 1. Flush fuel system and install correct fuel.   |
| l. External Compression Leaks                              | 1. Check for compression leaks at all nozzles and glow plugs, using "Leak-Tec" or equivalent. If leak is found, tighten nozzle or glow plug. |
| m. Plugged Nozzle(s)                                       | 1. Remove nozzles. Have them checked for plugging  |
| n. Low Compression   | 1. Check compression to determine cause.   |

Noise - "Rap"  
From One or More  
Cylinders (Sounds Like  
Rod Bearing Knock)

- |   |  |
|---|--|
| a. Nozzle(s) Sticking Open or With Very Low Nozzle Opening Pressure | 1. Loosen injection line at nozzle. If no R.P.M. drop remove and test. Replace as necessary. |
| b. Mechanical Problem   | 1. Refer to Mechanical Diagnosis.  |

## 6-14 ENGINE

|  |  |   |
|--|--|---|
| Excessive Black Smoke<br>And/or Objectionable<br>Combustion and Noise  | <ul style="list-style-type: none"><li>a. Timing Not To Specification</li><li>b. EGR Malfunction</li><li>c. Blocked Leg In Intake Manifold</li><li>d. Injection Pump Internal Problem</li></ul>   | <ul style="list-style-type: none"><li>1. Make certain timing marks are aligned.</li><li>1. Refer to Emission Diagnosis (Section 6E)</li><li>1. Probe Each Leg for Blockage.</li><li>1. Remove Injection Pump for Repair.</li></ul>  |
| Engine Noise -<br>Internal Or<br>External  | <ul style="list-style-type: none"><li>a. Engine Fuel Pump, Generator, Water Pump, Valve Train, Vacuum Pump, Bearings, Etc.</li></ul>   | <ul style="list-style-type: none"><li>1. Repair or replace as necessary. If noise is internal, see Diagnosis For Noise - Rap From One or More Cylinders and Engine Starts and Idles Rough With Excessive Noise and/or Smoke.</li></ul>  |
| Engine Overheats   | <ul style="list-style-type: none"><li>a. Coolant System Leak, Oil Cooler System Leak or Coolant Recovery System Not Operating.</li><li>b. Belt Slipping or Damaged</li><li>c. Thermostat Stuck Closed</li><li>d. Head Gasket Leaking</li></ul> | <ul style="list-style-type: none"><li>1. Check for leaks and correct as required. Check coolant recover jar, hose and radiator cap.</li><li>1. Replace or adjust as required.</li><li>1. Check and replace if required.</li><li>1. Check and repair as required.</li></ul>  |
| Instrument Panel<br>Oil Warning Lamp<br>"ON" at Idle   | <ul style="list-style-type: none"><li>a. Oil Cooler or Oil or Cooler Line Restricted</li><li>b. Oil Pump Pressure Low</li></ul>  | <ul style="list-style-type: none"><li>1. Remove restrictions in cooler or cooler line.</li></ul>  |
| Engine Will Not Shut<br>Off With Key<br>NOTE: With engine at<br>idle, pinch the fuel<br>return line at the<br>flexible hose to<br>shut off engine. | <ul style="list-style-type: none"><li>a. Injection Pump Fuel Solenoid Does Not Return Fuel Valve To "OFF" Position</li></ul>   | <ul style="list-style-type: none"><li>1. Refer to ELECTRICAL DIAGNOSIS.</li></ul>   |
| Engine Starts, Idles<br>Rough, WITHOUT<br>Abnormal<br>Noise or Smoke   | <ul style="list-style-type: none"><li>a. Slow Idle Incorrectly Adjusted</li><li>b. Injection Leaks</li><li>c. Restricted Fuel Return System</li><li>d. Air In System</li></ul>   | <ul style="list-style-type: none"><li>1. Adjust slow idle screw to specification.</li><li>1. Wipe off injection lines and connections. Run engine and check for leaks. Correct leaks.</li><li>1. Disconnect fuel return line at injection pump and route hose to a metal container. Connect a hose to the injection pump connection; route it to the metal container. Start the engine and allow it to idle; if engine idles normally, correct restriction in fuel return lines. If engine does not idle normally, remove the return line check valve fitting from the top of the pump and make sure it is not plugged.</li><li>1. Install a section of clear plastic tubing on the fuel return fitting from the engine. Evidence of bubbles in fuel when cranking or running indicates the presence of an air leak in the suction fuel line. Locate and correct.</li></ul> |

- |                                   |   |
|-----------------------------------|---|
| e. Incorrect or Contaminated Fuel | 1. Flush fuel system and install correct fuel.  |
| f. Nozzle(s) Malfunction          | 1. Loosen injection line at nozzle. If no RPM drop remove and test. Replace as necessary. |
| g. Glow Plug Inoperative          | 1. Replace.   |

## ENGINE COMPRESSION TEST (DIESEL ENGINES)

### COMPRESSION TEST

To determine if the valves or rings are the cause of low compression, a test should be made to determine the cylinder compression pressure.

When checking compression, the batteries should be at or near full charge. The lowest reading cylinder should not be less than 70% of the highest and no cylinder reading should be less than 275 p.s.i. (1900 kPa).

1. Remove air cleaner then install air crossover cover J-26996-1 or J-29664-2.
2. Disconnect the wire from the fuel solenoid terminal of the injection pump.

3. Disconnect wires from glow plugs then remove all glow plugs.
4. Screw J-26999-10 and compression gage J-26999 into glow plug hole of the cylinder that is being checked.
5. Crank engine.

This should be done with six "puffs" per cylinder.

**Normal**- Compression builds up quickly and evenly to specified compression on each cylinder.

- **Piston Rings Leaking** - Compression low on first stroke tends to build up on following strokes but does not reach normal.

**NOTICE:** Do not add oil to any cylinder to compression test as extensive damage may result.

## ENGINE COMPRESSION TEST (GASOLINE ENGINES)

### ENGINE COMPRESSION TEST

This should be done with four "puffs" per cylinder.

- **Normal** - Compression builds up quickly and evenly to specified compression on each cylinder.
- **Piston Rings Leaking** - compression low on first stroke tends to build up on following strokes but does not reach normal. Improves considerably with addition of oil.

- **Valves Leaking** - Low on first stroke does not tend to build up on following strokes. Does not improve much with addition of oil.  
Use approximately three squirts from a plunger type oiler.

1. Disconnect the "BAT" terminal from the HEI distributor.
2. When checking cylinder compression, the throttle and choke should be open, all spark plugs removed, and the battery at or near full charge. The lowest reading cylinder should not be less than 70% of the highest and no cylinder reading should be less than 100 pounds.

# 4.1 LITER L-6 VIN CODE D RPO (LE3)

# 4.8 LITER L-6 VIN CODE T RPO (L25)

## Contents

|  |    |   |    |
|--|----|---|----|
| General Description.....                     | 1  | Valves.....                               | 16 |
| Engine Lubrication.....                      | 2  | Torsional Damper.....                     | 16 |
| On Vehicle Service.....                      | 9  | Crankcase Front Cover.....                | 16 |
| Engine Mounts.....                           | 9  | Oil Seal (Front Cover).....               | 17 |
| Manifold Assembly-Non-Integrated Head.....   | 10 | Camshaft.....                             | 17 |
| Exhaust Manifold-Integrated Head.....        | 10 | Camshaft Bearings.....                    | 18 |
| Rocker Arm Cover.....                        | 11 | Oil Pan.....                              | 19 |
| Push Rod Side Cover.....                     | 11 | Oil Pump.....                             | 19 |
| Valve Mechanism.....                         | 11 | Engine Bearings.....                      | 20 |
| Valve Stem Oil Seal and/or Valve Spring..... | 11 | Oil Seal (Rear Main).....                 | 24 |
| Valve Lifters.....                           | 12 | Piston and Connecting Rod Assemblies..... | 25 |
| Cylinder Head.....                           | 14 | Flywheel.....                             | 28 |
| Rocker Arm Studs.....                        | 15 | Engine Assembly.....                      | 29 |
| Valve Guides.....                            | 15 | Crankshaft.....                           | 30 |
| Valve Seats.....                             | 16 | Specifications.....                       | 32 |

## GENERAL DESCRIPTION

### CYLINDER BLOCK

The cylinder block is made of cast iron and has 6 cylinders arranged "In-Line". Seven main bearings support the crankshaft which is retained by recessed bearing caps that are machined with the block for proper alignment and clearances. Cylinders are completely encircled by coolant jackets.

### CYLINDER HEAD

The cast iron cylinder head has individual intake and exhaust ports for each cylinder. Valve guides are integral and rocker arms are retained on individual threaded studs pressed into head. The 4.1 L(D) heads have integrated inlet manifolds. The 4.8 L(T) uses separate inlet manifolds.

### CRANKSHAFT AND BEARINGS

The crankshaft is cast nodular iron and is supported by seven main bearings. Number seven bearing is the end thrust bearing. Main bearings are lubricated from oil holes which intersect the main oil gallery located on the right side of the block. The cam bearings are also fed oil by intersecting holes with main oil gallery. The lifters are located in the main oil gallery.

A damper assembly, on the forward end of the crankshaft, dampens any engine torsional vibrations. The outer ring of the damper is grooved for the accessory drive belts.

### CAMSHAFT AND DRIVE

The cast iron camshaft is supported by four bearings and is gear driven. A cast iron crankshaft gear drives the aluminum camshaft gear. Cam lobes are ground, hardened and tapered with the high side toward the rear. This,

coupled with a spherical face on the lifters, causes the valve lifters to rotate.

### PISTONS AND CONNECTING RODS

The pistons are made of a cast aluminum alloy using two compression rings and one oil control ring.

Piston pins in the 4.1 L (D) engine are offset .060" (1.5mm) toward the thrust side (right hand side) to provide a gradual change in thrust pressure against the cylinder wall as the piston travels its path. This also provides for quieter operation. 4.8 L (T) engine piston pins are on piston centerline for best durability and reduced friction. Pins are chromium steel and have a floating fit in the pistons. They are retained in the connecting rods by a press fit.

Connecting rods are made of forged steel. Full pressure lubrication is directed to the connecting rods by drilled oil passages from the adjacent main bearing journal. Oil holes at the connecting rod journals are located so that oil is supplied to give maximum lubrication just prior to full bearing load.

### VALVE TRAIN

A very simple ball pivot-type train is used. Motion is transmitted from the camshaft through the hydraulic lifters and push rods to the rocker arms. The rocker arm pivots on its ball and transmits the camshaft motion to the valve. The rocker arm ball is retained by a self locking nut.

### HYDRAULIC VALVE LIFTERS

Hydraulic Valve Lifters are used to keep all parts of the valve train in constant contact for quiet operation.

The hydraulic lifter assembly consists of: the lifter body, which rides in the cylinder block boss, a plunger, a push rod seat, a metering valve, a plunger spring, a check ball and spring, a check ball retainer and a push rod seat retainer.

When the lifter is riding on the low point (base circle) of the cam, the plunger spring keeps the plunger and push rod seat in contact with the push rod.

When the lifter body begins to ride up the cam lobe, the check ball traps the oil in the reservoir below the plunger. The plunger and lifter body then rise as a unit, pushing up the push rod and opening the valve. A very small amount of oil will leak out between the plunger and the body.

As the lifter body rides down the other side of the cam, the plunger follows with it until the valve closes. The lifter body continues to follow the cam to its low point, but the plunger spring keeps the plunger in contact with the push rod. The ball check valve will then move off its seat and the lifter reservoir will be refilled with oil.

## Engine Lubrication

Full pressure lubrication, through a full flow oil filter is furnished by a gear-type oil pump. The distributor, driven by a helical gear on the camshaft, drives the oil pump.

Oil drawn by the pick-up screen and pipe is pressurized in the pump and routed to the oil filter. If excessive backpressure is encountered at the filter, a bypass valve allows oil flow to the main oil gallery, located along the right side of the block. This rifle drilled gallery supplies oil to the camshaft bearings, the hydraulic lifters and the crankshaft main bearings.

### INTAKE MANIFOLD

The intake manifold is of cast iron, single level design for efficient fuel distribution. The 4.1 L (D) manifold is an integral unit with the head on all vehicles. 4.8 L (T) engines use separate components. The carburetor pad is centrally located with an early fuel evaporation (EFE) passage running underneath the pad, through which exhaust gases are forced, to promote faster fuel vaporization when the engine is cold. An exhaust gas recirculation port is also cast into the manifold on 4.1 L (D) engines, for the induction of a metered amount of exhaust gases into the air and fuel mixture which has entered through the carburetor.

### EXHAUST MANIFOLD

On 4.8 L (T) engines a single four port, underslung, center take down manifold of nodular iron is used to direct exhaust gases from the combustion chambers. On 4.1 L (D) engines a single four port, underslung, dual center take down manifold of nodular iron is used. A heat shield is mounted to the manifold that is used to route heated air to the air cleaner for better fuel vaporization.

The connecting rod bearings are supplied oil from the crankshaft main bearings by means of cross drilled passages.

The valve train is supplied its lubrication from the valve lifters. Oil within the lifters is pumped up through the top of the lifters through the hollow push rods to the rocker arms. From the head, oil is drained back to the crankcase through oil drain back holes and the push rod holes. (Fig. 6A1-1).

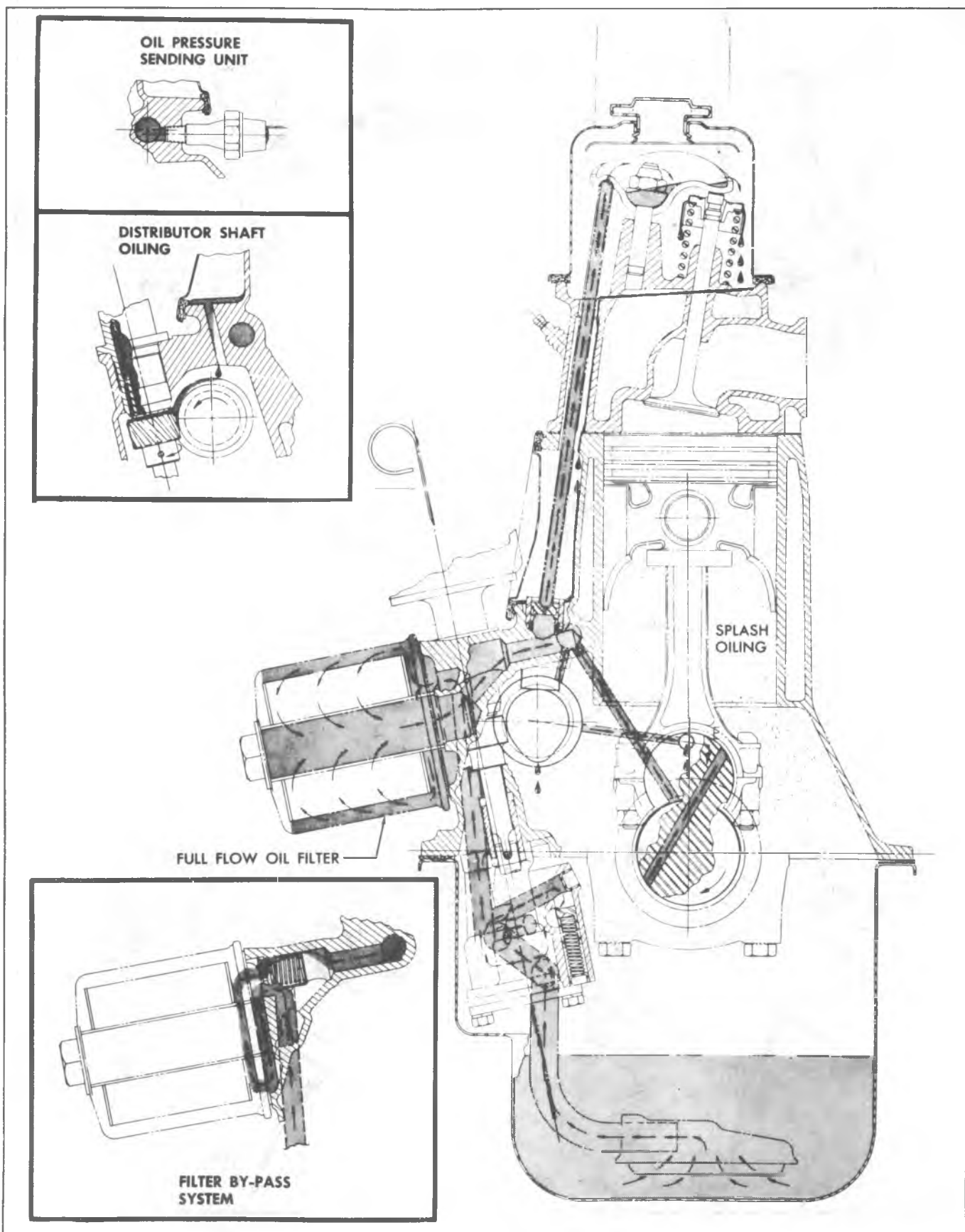

Fig. 6A1-1--In-Line Engine Lubrication

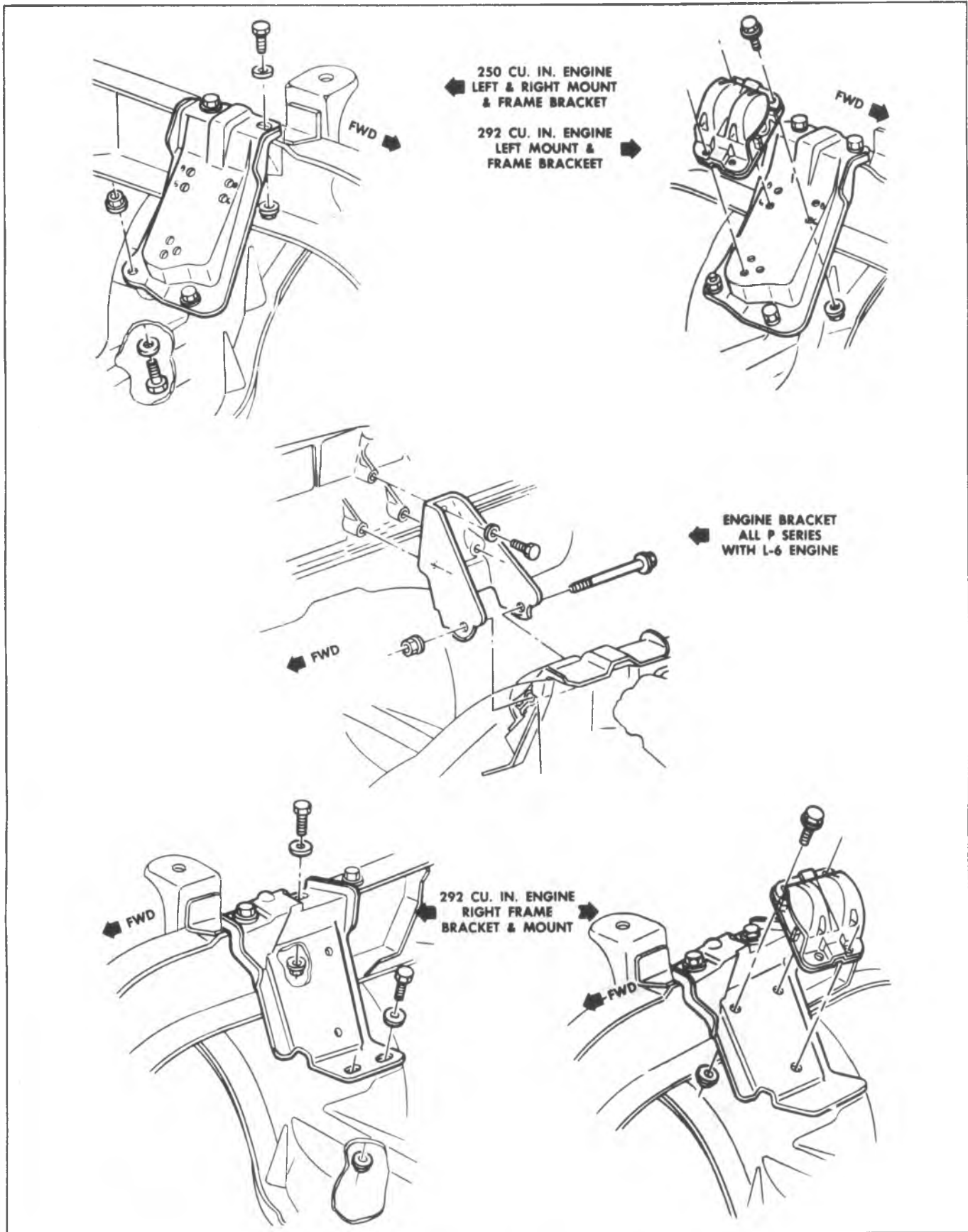

Fig. 6A1-2--"P" Series - Engine Front Mount

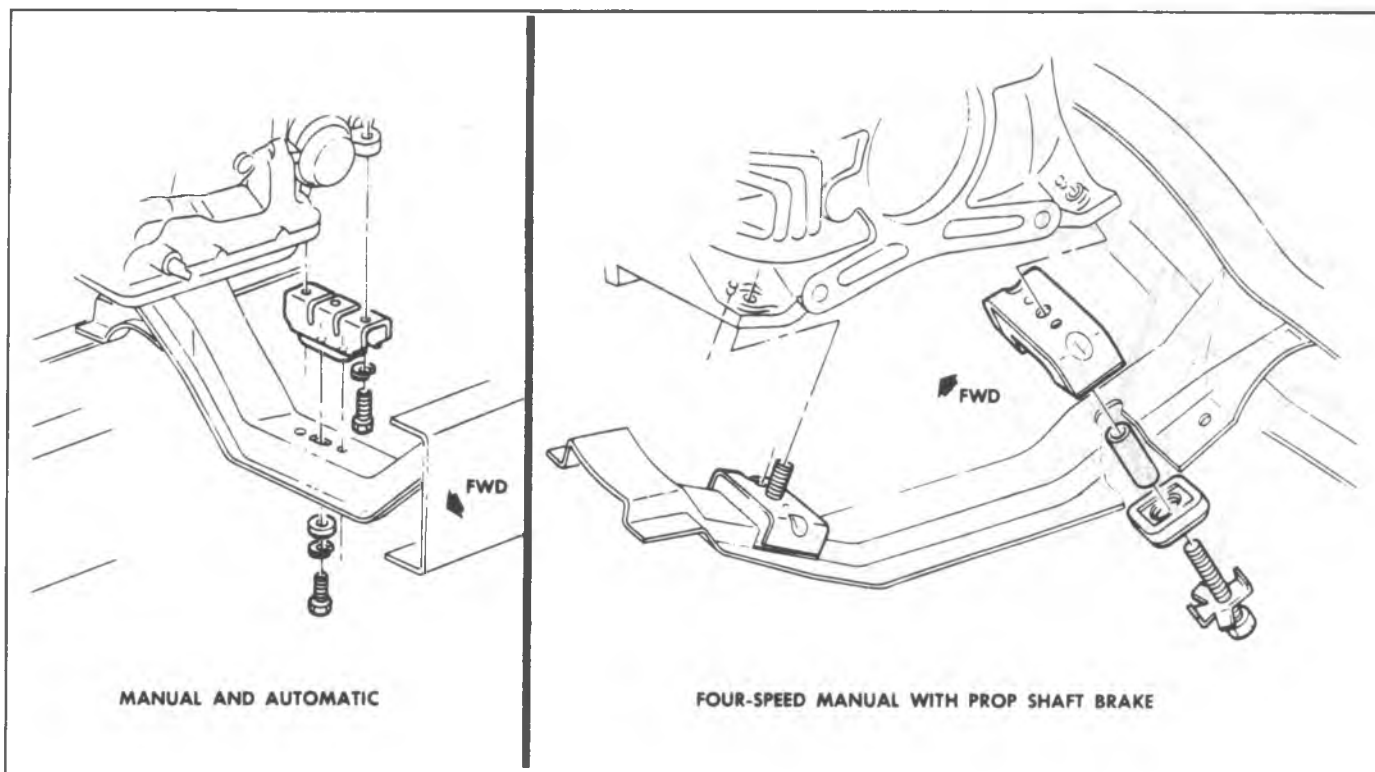

Fig. 6A1-3--"P" Series - Engine Rear Mount

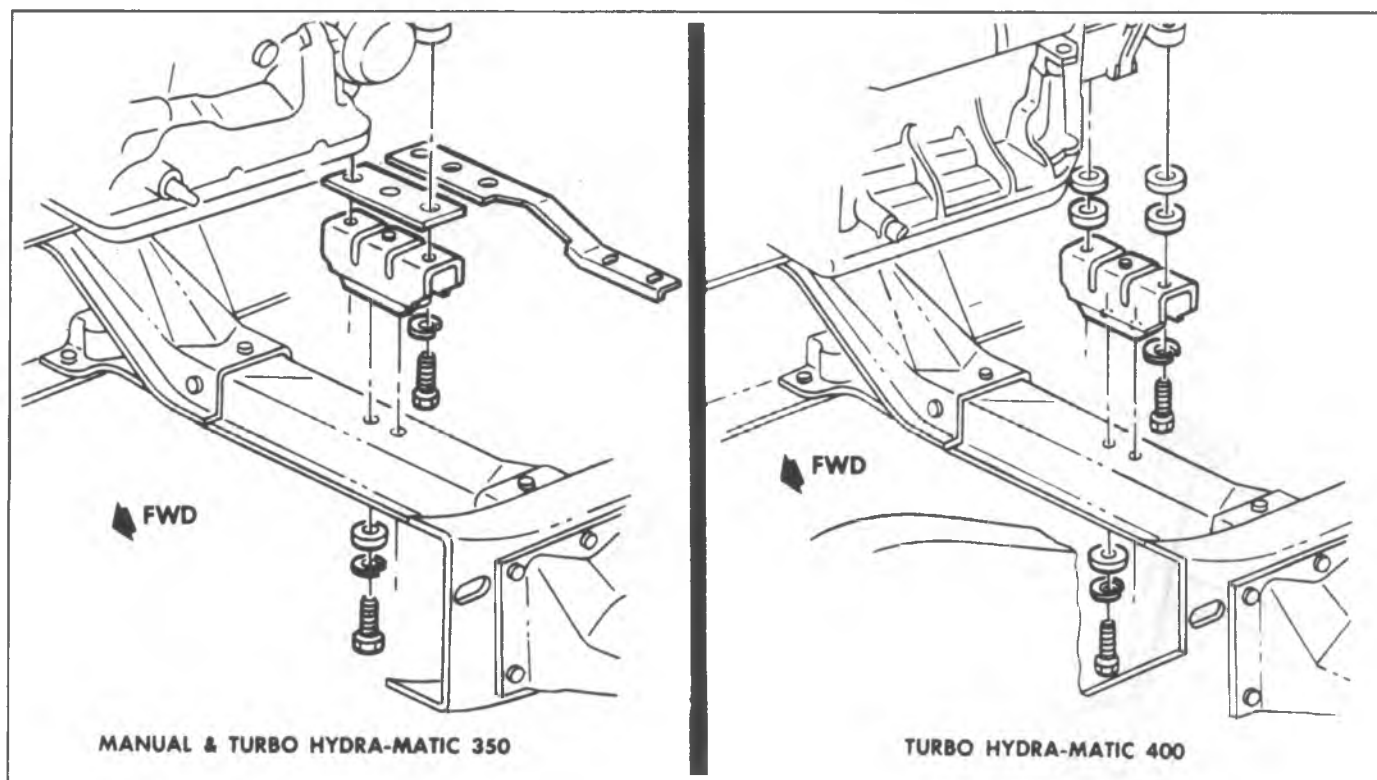

Fig. 6A1-4--"C" Series - Engine Rear Mounts



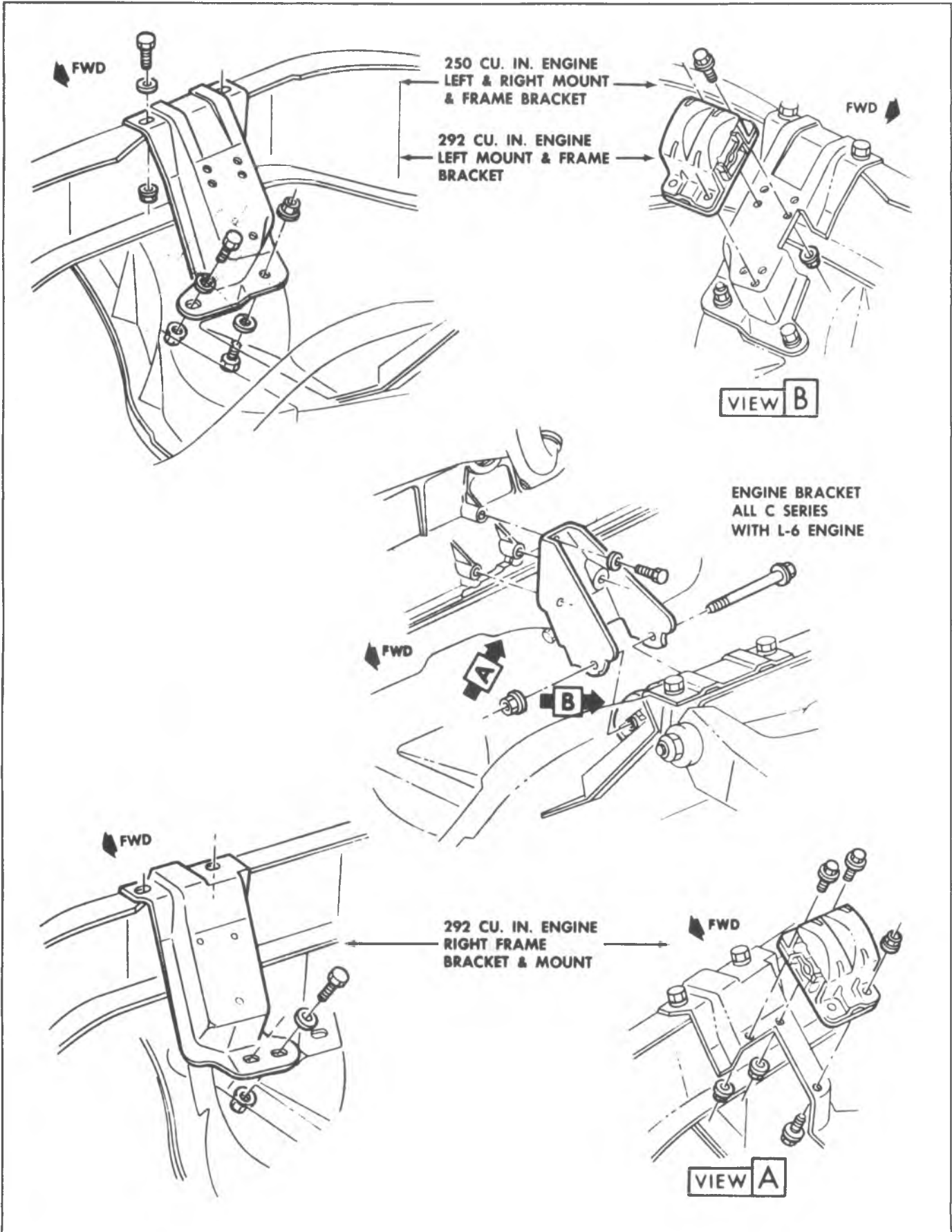
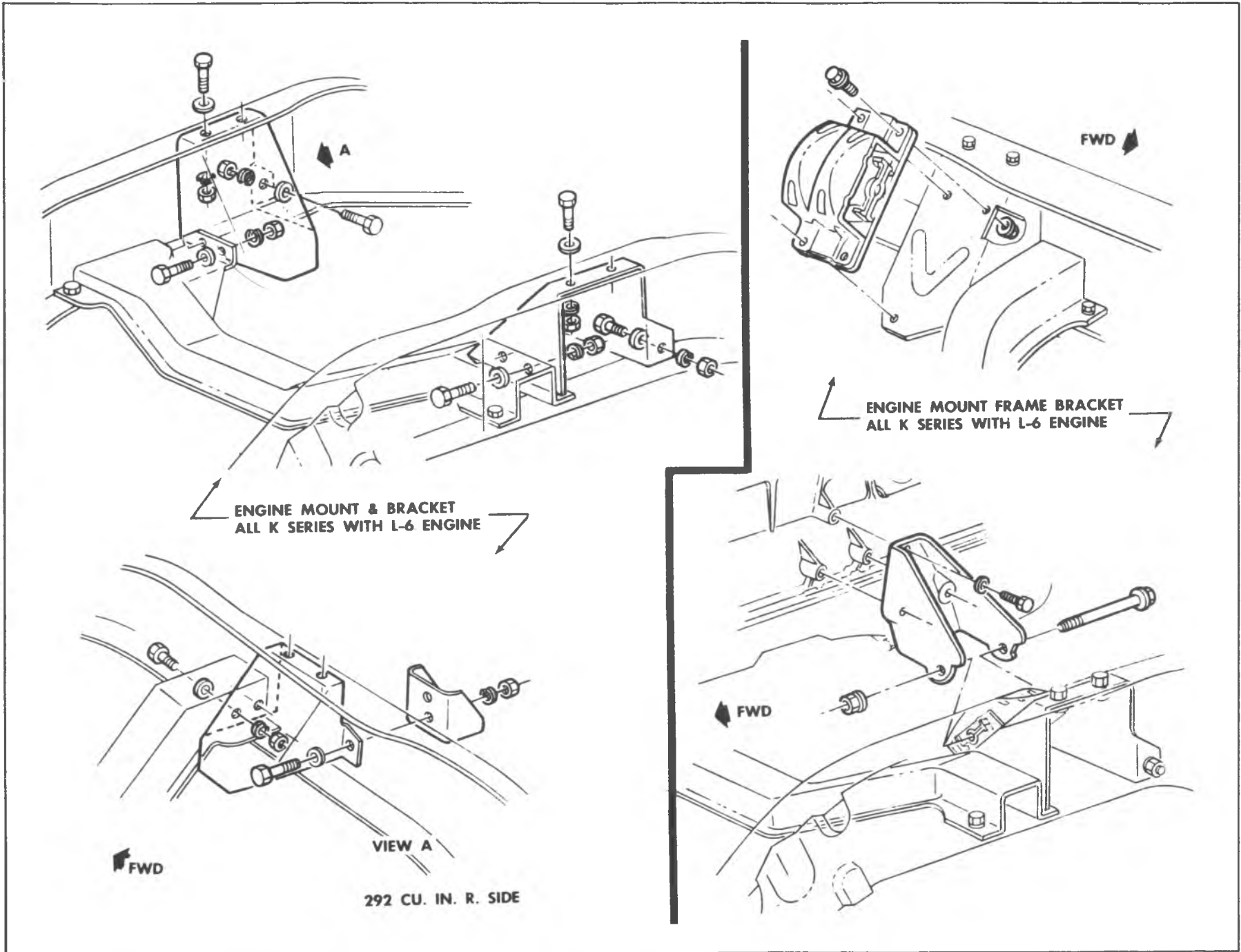

Fig. 6A1-5--"C" Series - Engine Front Mount

Fig. 6A1-6--"K" Series - Engine Front Mount



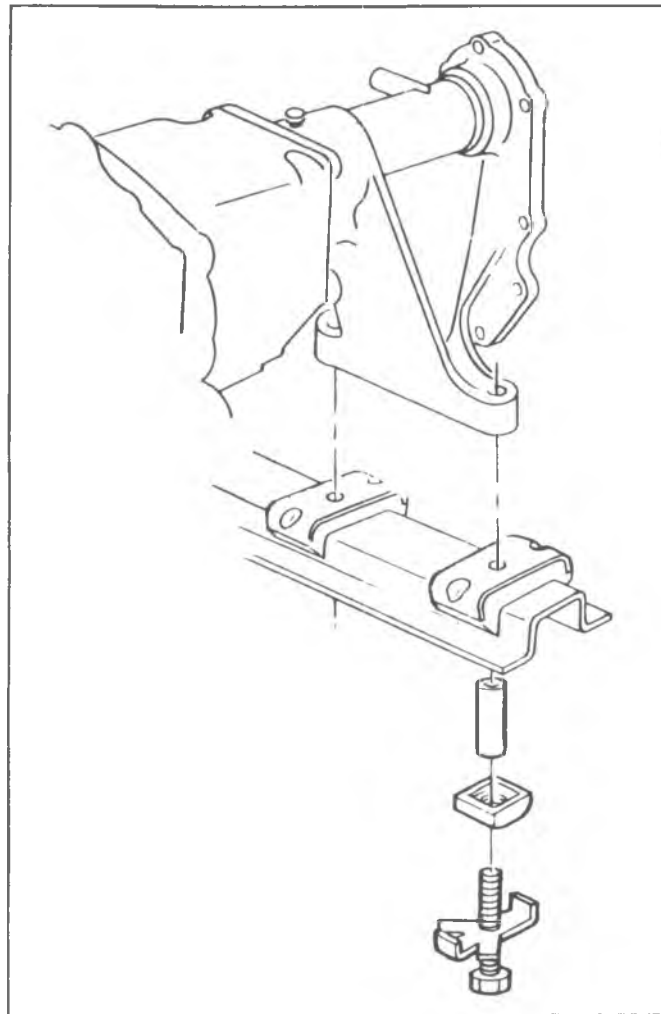

Fig. 6A1-7--"K" Series - Engine Rear Mount

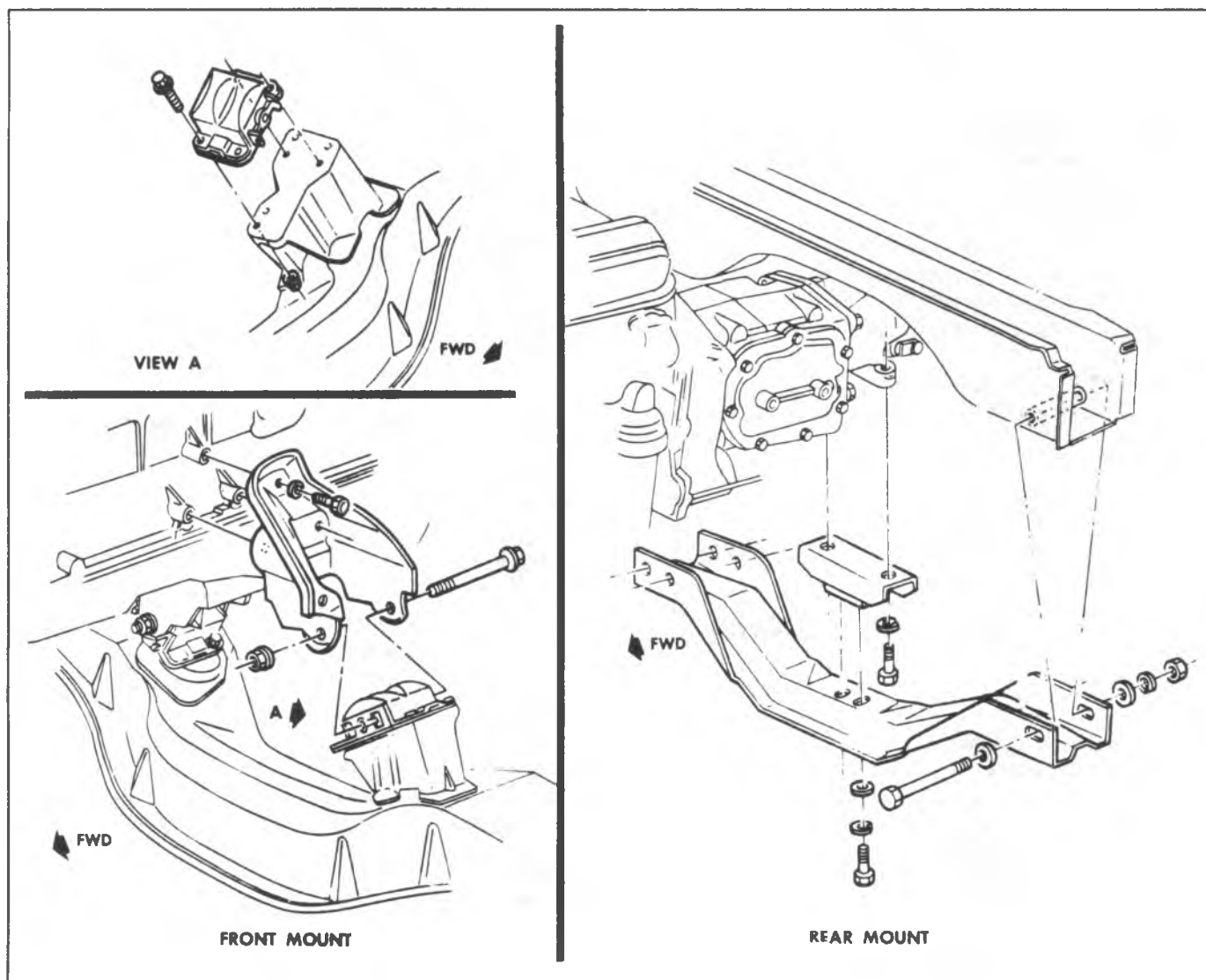

Fig. 6A1-8--"G" Series - Engine Mounts

## ON VEHICLE SERVICE

### ENGINE MOUNTS

Engine mounts (Fig. 6A1-2 - 6A1-8) are the non-adjustable type and seldom require service. Broken or deteriorated mounts should be replaced immediately, because of the added strain placed on other mounts and drive line components.

#### Checking Engine Mounts

##### Front Mount

Raise the engine to remove weight from the mounts and to place a slight tension in the rubber. Observe both mounts while raising engine. If an engine mount exhibits:

- a. Hard rubber surface covered with heat check cracks;
- b. Rubber separated from a metal plate of the mount;
- c. Rubber split through center,

replace the mount. If there is relative movement between a metal plate of the mount and its attaching points,

lower the engine on the mounts and tighten the screws or nuts attaching the mount to the engine, frame, or bracket.

##### Rear Mount

Raise the vehicle on a hoist. Push up and pull down on the transmission tailshaft while observing the transmission mount. If the rubber separates from the metal plate of the mount or if the tailshaft moves up but not down (mount bottomed out) replace the mount. If there is relative movement between a metal plate of the mount and its attaching point, tighten the screws or nuts attaching the mount to the transmission or crossmember.

##### Front Mount Replacement

1. Remove engine mount through bolt.
2. Raise engine and remove mount to frame bracket attaching bolts. Remove mount. Raise engine only enough for sufficient clearance. Check for interference between rear of engine and cowl panel.

3. Install new engine mount to frame bracket and torque attaching bolts to specifications.
4. Install engine mount through bolt and torque to 30 lb. ft. (40 N·m) specifications.

#### Rear Mount Replacement

1. Support engine weight to relieve rear mounts.
2. Remove crossmember-to-mount bolts.
3. On "P" Series with manual transmission and propeller shaft parking brake, remove mount attaching bolts from frame outrigger and clutch housing and remove rear mounting cushions.
4. Remove mount-to-transmission bolts, then remove mount.
5. On "P" Series with manual transmission and propeller shaft parking brake, install new mounting cushions and bolts.
6. Install new mount on transmission.
7. While lowering transmission, align and start cross-member-to-mount bolts.
8. Torque bolts to 45 lb. ft. (60 N·m) then bend lock tabs to bolt head as applicable.

#### MANIFOLD ASSEMBLY - NON-INTEGRATED HEAD

##### Removal

1. Disconnect battery negative cable at battery.
2. Remove air cleaner.
3. Disconnect both throttle controls at bellcrank and remove throttle return spring.
4. Disconnect fuel and vacuum lines at carburetor.
5. Disconnect crankcase ventilation hose at rocker arm cover.
6. Disconnect vapor hose at canister.
7. Disconnect exhaust pipe at manifold flange.
8. Remove manifold attaching bolts and clamps then remove manifold assembly.
9. Check for cracks in manifold castings.
10. Separate manifolds by removing one bolt and two nuts at center of assembly.
11. Observe gaskets and packing if necessary to diagnose a leakage problem.

##### Installation

1. Clean gasket surfaces on cylinder head and manifolds.
2. Lay a straight edge along the full length of the exhaust port faces and measure any gaps between the straight edge and the port faces. If at any point a gap of .030" (.80mm) or more exists, it is likely that the manifold has distorted to a point where it will not seat properly. If a good exhaust seal is to be expected, the exhaust manifold must be replaced.
3. Assemble intake and exhaust manifolds using a new gasket by reinstalling the one bolt and two nuts at the center of the manifold to finger tight.
4. Position a new gasket over manifold end studs on the cylinder head.
5. Install manifold assembly bolts, clamps and washers while holding manifold assembly in place by hand.

6. Clean, oil and torque all manifold assembly to cylinder head bolts and nuts to 40 lbs. ft. (55 N·m).
7. Complete torquing the inlet to exhaust manifold bolt and two nuts at the center of the manifold to 45 lb. ft. (61 N·m).
8. Connect exhaust pipe to manifold using a new packing.
9. Connect crankcase ventilation hose at rocker arm cover.
10. Connect vapor hoses at canister.
11. Connect fuel and vacuum lines a carburetor.
12. Connect throttle controls at bellcrank and install throttle return spring.
13. Install air cleaner, start engine, check for leaks and adjust carburetor idle speed.

#### EXHAUST MANIFOLD ASSEMBLY - INTEGRATED HEAD

##### Removal

1. Disconnect negative battery cable.
2. Remove air cleaner.
3. Remove power steering pump and/or A.I.R. pump brackets, if so equipped.
4. Remove PAIR pipes as outlined in Section 6E.
5. Raise vehicle on hoist and disconnect exhaust pipe at manifold and converter bracket at transmission mount.
6. Lower vehicle.
7. Remove exhaust manifold bolts.
8. Remove exhaust manifold, check EFE Valve to see if free and check manifold for cracks.

##### Installation

If a new exhaust manifold is being installed, the E.F.E. valve and actuator and rod assembly must be transferred from the old component.

1. Clean gasket surface and position new gasket on exhaust manifold.
2. Install manifold bolts, while holding manifold assembly in place.
3. Torque all manifold to cylinder head bolts in sequence to torques shown in figure 6A1-9.
4. Raise vehicle on hoist.
5. Connect exhaust pipe at manifold flange and converter bracket at transmission mount. Attach exhaust pipe and align exhaust system. Torque attaching bolts to specification.

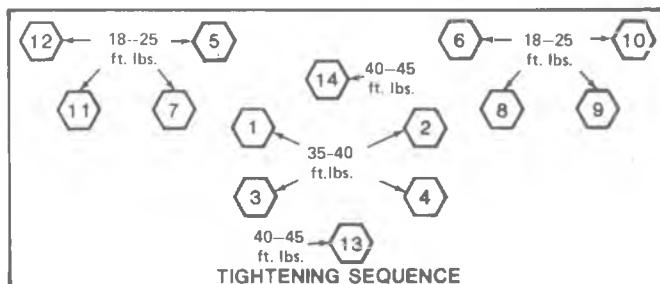

Fig. 6A1-9--Cylinder Head To Exhaust Manifold Tightening Sequence

6. Lower vehicle.
7. Install PAIR pipes as outlined in Section 6E.
8. Install power steering pump and/or A.I.R. pump and brackets, if so equipped. Tighten drive belt using strand tension gage.
9. Install air cleaner.
10. Connect negative battery cable.
11. Start engine and check for leaks.

## ROCKER ARM COVER

### Removal

1. Disconnect crankcase ventilation hose(s) at rocker arm cover.
2. Remove air cleaner.
3. Disconnect all wires, fuel and vacuum pipes from rocker arm cover clips.
4. On LE3 engines, remove pulse air pipes (as outlined in Section 6E) and disconnect accelerator linkage and springs from bracket.
5. Remove rocker arm cover bolts and remove cover.

**NOTICE:** If cover adheres to cylinder head, try bumping end of rocker arm cover with a rubber mallet. If cover still will not come loose, CAREFULLY pry until loose. DO NOT DISTORT SEALING FLANGE.

### Installation

1. Clean sealing surfaces on cylinder head and rocker arm cover with degreaser. Remove all loose pieces of RTV or pieces that will cause installation interference.
2. Place a 3/16" (5mm) bead of RTV sealant, # 1052366 or equivalent, all around the rocker arm cover sealing surface of the cylinder head. When going around the attaching bolt holes, always flow the RTV on the inboard side of the holes.
3. Place cover on head while RTV is still wet, install retaining bolts and torque to 45 lb. in. (5N·m).
4. Connect wires, fuel and vacuum pipes at rocker arm cover clips.
5. Install pulse air pipes (as outlined in Section 6E), and accelerator linkage and springs where removed.
6. Install air cleaner.
7. Connect crankcase ventilation hoses (where so equipped).

## PUSH ROD SIDE COVER

### Removal

1. Disconnect battery negative cable.
2. "CK" Models-Remove dipstick tube (rear cover).
3. Remove cover bolts.
4. Remove cover. If cover sticks to block, a heated knife blade, or similar device, used to pry at the sealing surfaces will aid in removal.

### Installation (Front Cover)

1. Clean sealing surfaces of both the cover and block with degreaser. Remove loose RTV, or pieces causing installation interference.
2. Place a continuous 1/8" (3mm) bead of RTV sealant, # 1052366 or equivalent, all around the cover sealing

surface. Place cover on block while sealant is still wet (within 10 minutes). Install retaining bolts and torque to 50 lb. in. (5.6 N·m).

3. "CK" Models - Clean dipstick tube and apply sealant # 1052080 or equivalent around tube 1/2" below bead. Install dipstick tube.
4. Connect battery negative cable.

## VALVE MECHANISM

### Removal

1. Remove rocker arm cover as previously outlined.
2. Remove rocker arm nuts, rocker arm balls, rocker arms and push rods. Place rocker arms, rocker arm balls and push rods in a rack so that they may be reinstalled in the same location.

### Installation and Adjustment

Whenever new rocker arms and/or rocker arm balls are being installed, coat bearing surfaces of rocker arms and rocker arm balls with "Molykote" or its equivalent.

1. Install push rods. Be sure push rods seat in lifter socket.
2. Install rocker arms, rocker arm balls and rocker arm nuts. Tighten rocker arm nuts until all lash is eliminated.
3. Adjust valves when lifter is on base circle of camshaft lobe as follows:
  - a. Mark distributor housing, with chalk, at #1 and #6 positions (plug wire). Remove distributor cap and lay aside.
  - b. Crank engine until distributor rotor points to #1 cylinder position. The following valves can be adjusted with engine in #1 firing position:
    - #1 cylinder-Exhaust and Intake.
    - #2 cylinder-Intake
    - #3 cylinder-Exhaust
    - #4 cylinder-Intake
    - #5 cylinder-Exhaust
  - c. Back out adjusting nut until lash is felt at the push rod then turn in adjusting nut until all lash is removed. This can be determined by rotating the push rod while turning adjusting nut (Fig. 6A1-10). When play has been removed, turn adjusting nut in one full additional turn (to center lifter plunger).
  - d. Crank engine until distributor rotor points to #6 position. The following valves can be adjusted with engine in #6 firing position:
    - #2 cylinder-Exhaust
    - #3 cylinder-Intake
    - #4 cylinder-Exhaust
    - #5 cylinder-Intake
    - #6 cylinder-Intake and Exhaust
4. Install distributor cap.
5. Install rocker arm cover as outlined.
6. Adjust carburetor idle speed (if necessary).

## VALVE STEM OIL SEAL AND/OR VALVE SPRING

### Replacement

1. Remove rocker arm cover as previously outlined.

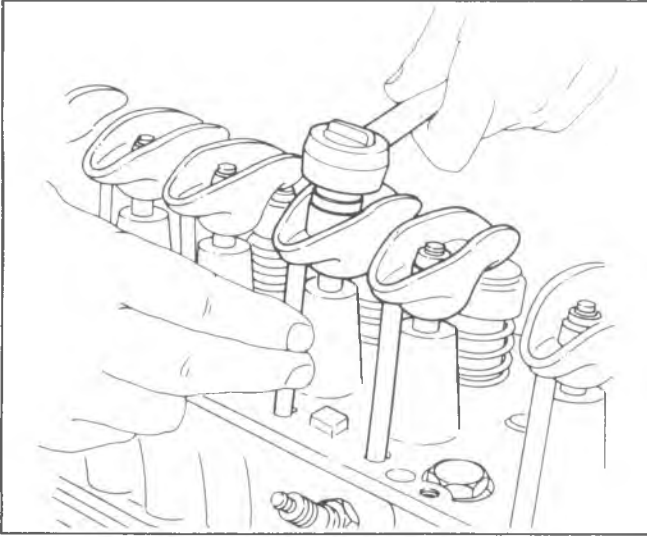

Fig. 6A1-10--Valve Adjustment

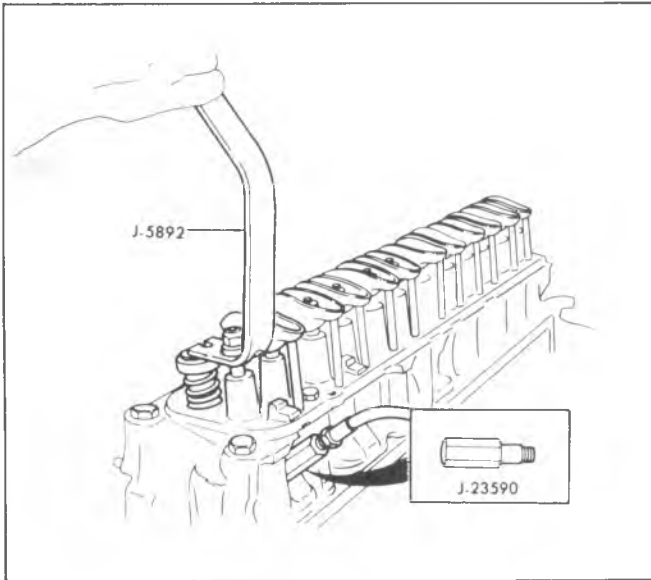

Fig. 6A1-11--Compressing Valve Spring

2. Remove spark plug, rocker arm and push rod on the cylinder(s) to be serviced.
3. Install air line adapter Tool J-23590 to spark plug port and apply compressed air to hold the valves in place.
4. Using Tool J-5892 to compress the valve spring, remove the valve locks, valve cap, valve shield and valve spring and damper (fig. 6A1-11).
5. Remove the valve stem oil seal.
6. To replace, set the valve spring, oil shedder and valve cap in place. Compress the spring with Tool J-5892 and install new oil seal in the lower groove of the stem, making sure the seal is flat and not twisted. A light coat of oil on the seal will help prevent twisting.
7. Install the valve locks and release the compressor tool, making sure the locks seat properly in the upper groove

of the valve stem. Grease may be used to hold the locks in place while releasing the compressor tool.

8. Using Tool J-23994, apply vacuum to the valve assembly to make sure no air leaks past the seal.
9. Install spark plug, and torque to 15 lb. ft. (20 N·m).
10. Install and adjust valve mechanism as previously outlined.

## VALVE LIFTERS

Hydraulic valve lifters very seldom require attention. The lifters are extremely simple in design. Readjustments are not necessary, and servicing of the lifters requires only that care and cleanliness be exercised in the handling of parts.

### Removal

1. Remove rocker arm cover and loosen rocker arms sufficiently to remove the push rods. Place push rods in a rack so that they may be returned to their original location.
2. Mark distributor housing, with chalk, at #1 and #6 positions. Remove distributor cap and lay aside.
3. Remove push rod covers as outlined.
4. Remove valve lifters. Place valve lifters in a rack so that they may be installed in the same location.

### Disassembly

1. Hold the plunger down with a push rod, and using the blade of a small screw driver, remove the push rod seat retainer.
2. Remove the push rod seat and metering valve (fig. 6A1-12).
3. Remove the plunger, ball check valve assembly and the plunger spring.
4. Remove the ball check valve and spring by prying the ball retainer loose from the plunger with the blade of a small screw driver (fig. 6A1-13).

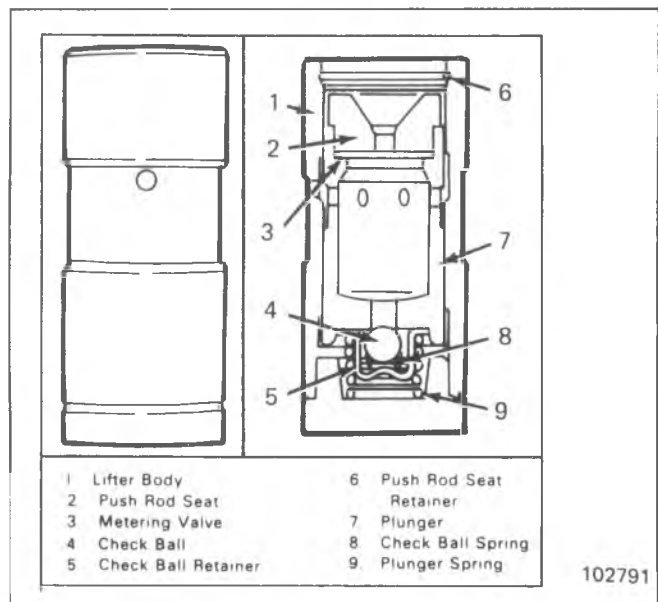

102791

Fig. 6A1-12--Hydraulic Valve Lifter

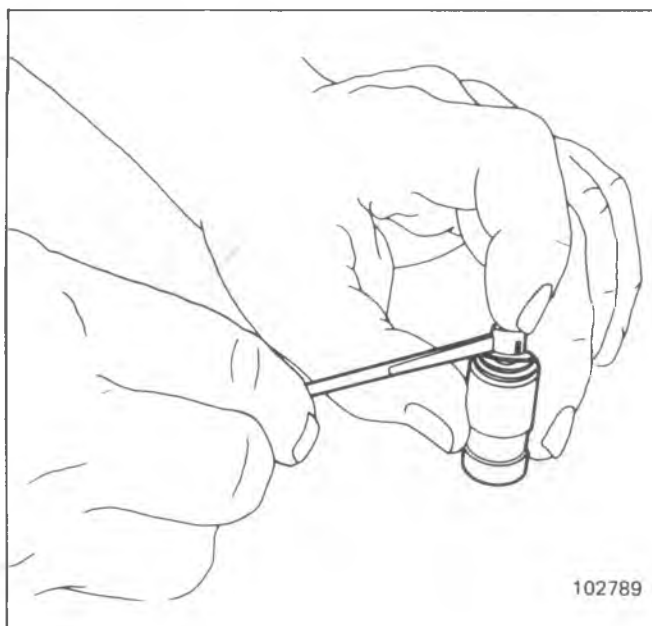

Fig. 6A1-13--Removing Ball Check Valve

### Cleaning and Inspection

Thoroughly clean all parts in cleaning solvent, and inspect them carefully. If any parts are damaged or worn, the entire lifter assembly should be replaced. If the lifter body wall is scuffed or worn, inspect the cylinder block lifter bore, if the bottom of the lifter is scuffed or worn inspect the camshaft lobe, if the push rod seat is scuffed or worn inspect the push rod.

An additive containing EP lube, such as EOS, should always be added to crankcase oil for run-in when any new camshaft or lifters are installed. All damaged or worn lifters should be replaced.

For proper lifter rotation during engine operation, lifter foot must be convex.

Whenever a new camshaft is installed, replace oil, oil filter and all valve lifters. Install GM E.O.S. or equivalent over the cam and lifter feet after the parts are installed.

### Assembly

1. Place the check ball on small hole in bottom of the plunger.
2. Insert check ball spring on seat in ball retainer and place retainer over ball so that spring rests on the ball. Carefully press the retainer into position in plunger with the blade of a small screw driver (fig. 6A1-14).
3. Place the plunger spring over the ball retainer and slide the lifter body over the spring and plunger, being careful to line up the oil feed holes in the lifter body and plunger.
4. Fill the assembly with SAE 10 oil, then insert the end of a 1/8" (3mm) drift pin into the plunger and press down solid. (Do not attempt to force or pump the plunger). At this point oil holes in the lifter body and plunger assembly will be aligned (fig. 6A1-15).
5. Insert a 1/16" (1.6mm) drift pin through both oil holes to hold the plunger down against the lifter spring tension (fig. 6A1-15).

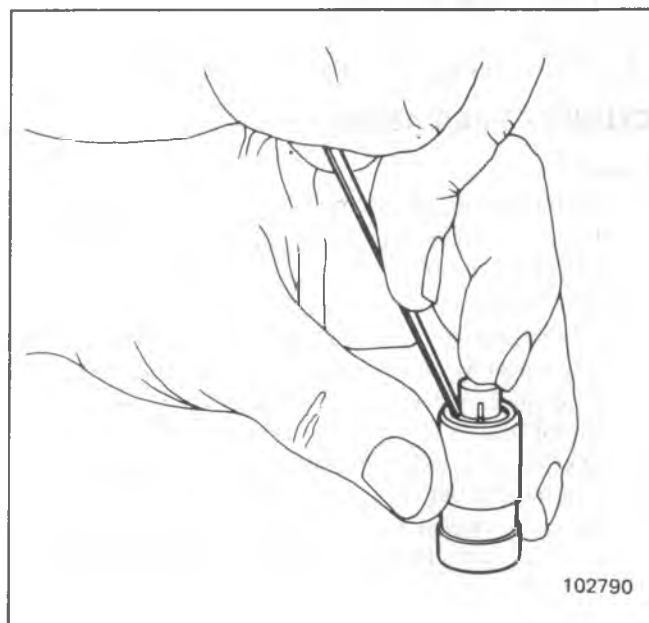

Fig. 6A1-14--Installing Ball Check Valve

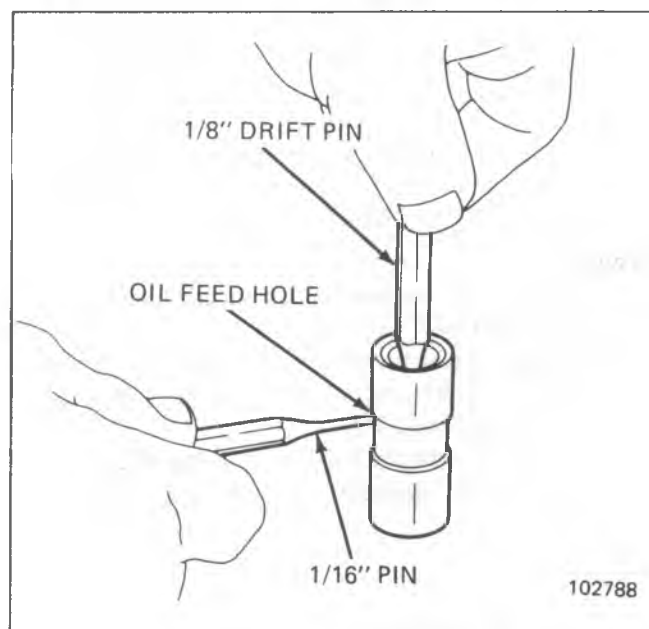

Fig. 6A1-15--Assembling Hydraulic Lifter

6. Remove the 1/8" (3mm) drift pin, refill assembly with SAE 10 oil.
7. Install the metering valve and push rod seat (refer to fig. 6A1-12).
8. Install the push rod seat retainer, press down on the push rod seat and remove the 1/16" (1.6mm) drift pin from the oil holes. The lifter is now completely assembled, filled with oil and ready for installation.

### Installation

1. Coat foot of valve lifters with "Molykote" or its equivalent. Install valve lifters.
2. Using a 1/8" (3mm) bead of RTV, #1052366 or equivalent, on the covers, install push rod side covers and torque bolts to specifications.
3. Install distributor cap.



4. Install push rods and adjust valve mechanism as outlined.
5. Adjust ignition timing and carburetor idle speed.

## CYLINDER HEAD ASSEMBLY

### Removal

1. Remove manifold assembly as previously outlined.
2. Remove rocker arm cover and valve mechanism as previously outlined.
3. Drain cooling system.
4. Remove fuel and vacuum line from retaining clips then disconnect wires from temperature sending units.
5. Disconnect air injection hose at check valve (if so equipped).
6. Disconnect radiator upper hose at coolant outlet housing and battery ground strap.
7. Remove cylinder head bolts, cylinder head and gasket. Place cylinder head on two blocks of wood to prevent damage.

### Disassembly

1. With the cylinder head removed, use tool J-8062 to compress the valve springs and remove the valve keys. Release the compressor tool and remove rotators or spring caps, oil shields springs and spring damper assemblies, then remove oil seals and valve spring shims.
2. Remove valves from cylinder head and place them in a rack in their proper sequence so that they can be assembled in their original positions.

### Cleaning

1. Clean all deposits from combustion chambers and valve ports using Tool J-8089.
2. Thoroughly clean the valve guides using Tool J-8101.
3. Clean all carbon and sludge from push rods, rocker arms and push rod guides.
4. Clean valve stems and heads on a buffing wheel.
5. Clean carbon deposits from head gasket mating surface.

### Inspection

1. Inspect the cylinder head for cracks in the exhaust ports, combustion chambers, or external cracks to the water chamber.
2. Inspect the valves for burned heads, cracked faces or damaged stems.

**NOTICE:** Excessive valve stem to bore clearance will cause excessive oil consumption and may cause valve breakage. Insufficient clearance will result in noisy and sticky functioning of the valve and disturb engine smoothness.

3. Measure valve stem clearance as follows:
  - a. Clamp a dial indicator on one side of the cylinder head rocker arm cover sealant rail. Locate the indicator so that movement of the valve stem from side to side (crosswise to the head) will cause a direct movement of the indicator stem.
  - b. Drop the valve head about 1/16" (1.6mm) off the valve seat.

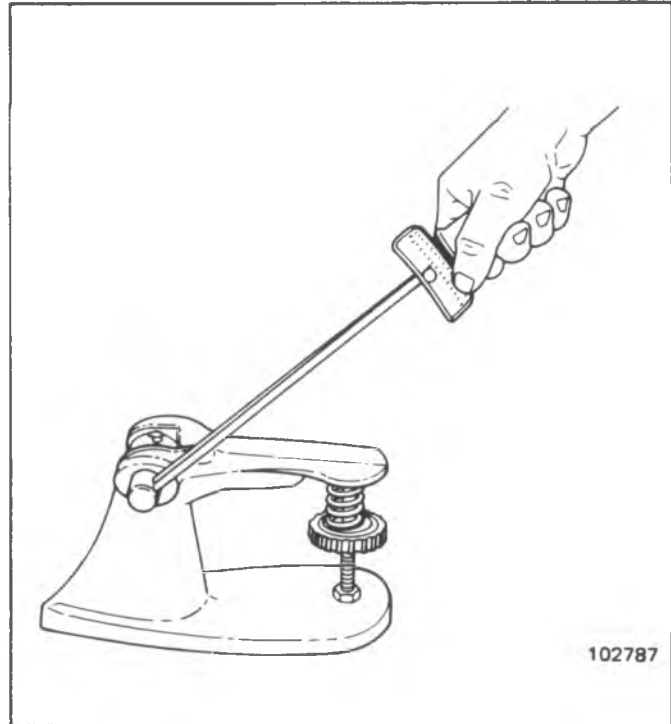

Fig. 6A1-16--Checking Valve Spring Tension

- c. Move the stem of the valve from side to side using light pressure to obtain a clearance reading. If clearance exceeds specifications it will be necessary to ream valve guides for oversize valves as outlined.
4. Check valve spring tension with Tool J-8056 spring tester (fig. 6A1-16). Springs should be replaced if not within 10 lbs. (44 N) of the specified load (without dampers).
5. Inspect rocker arm studs for wear or damage.

### Assembly

1. Insert valves in the proper ports.
2. Set the valve spring shim, valve spring (with damper), oil shields and valve cap or rotator in place (fig. 6A1-17).
3. Compress the spring with Tool J-8062.

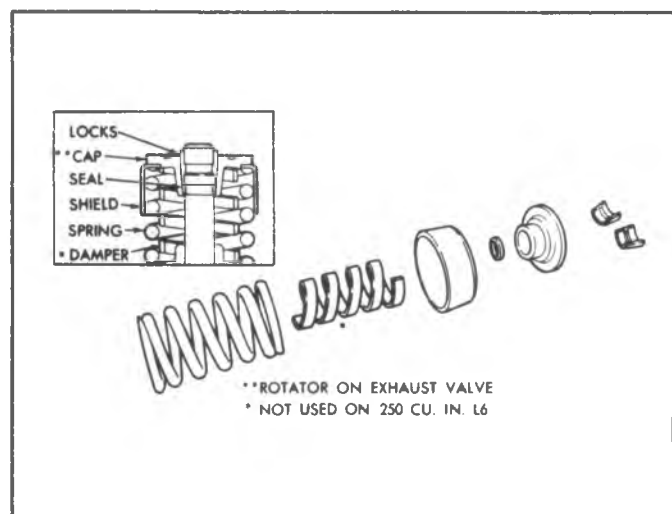

Fig. 6A1-17--Valve Spring Installation

\* ROTATOR ON EXHAUST VALVE  
\* NOT USED ON 250 CU. IN. I6

4. Install new oil seal in the lower groove of the stem, making sure that the seal is flat and not twisted.
5. Install the valve keys and release the compressor tool, making sure that the keys seat properly in the upper groove of the valve stem.
6. Using Tool J-23994, apply vacuum to the valve assembly to make sure no air leaks past the seal.

### Installation

The gasket surfaces on both the head and the block must be clean of any foreign matter and lay aside.

Cylinder bolt threads in the block and threads on the cylinder head bolt must be cleaned. (Dirt will affect bolt torque.) Do not use gasket sealer on composition steel asbestos gasket.

1. Place the gasket in position over the dowel pins.
2. Carefully guide cylinder head into place over dowel pins and gasket.
3. Coat threads of cylinder head bolts with sealing compound, #1052080 or equivalent, and install finger tight.
4. Tighten cylinder head bolts a little at a time until 95 lb. ft. (125 N·m) torque is reached. The left-hand front head bolt torque is 85 lb. ft. (115 N·m).
5. Connect radiator upper hose and engine ground strap.
6. Connect temperature sending unit wires and install fuel and vacuum lines in clips.
7. Fill cooling system.
8. Install manifold assembly as previously outlined.
9. Install and adjust valve mechanism as previously outlined.
10. Install and torque rocker arm cover.
11. Connect AIR pipe (if so equipped).

## ROCKER ARM STUDS

### Replacement

Rocker arm studs that have damaged threads or are loose in cylinder heads should be replaced with new studs available in .003" and .013" oversize. Studs may be installed after reaming the holes as follows:

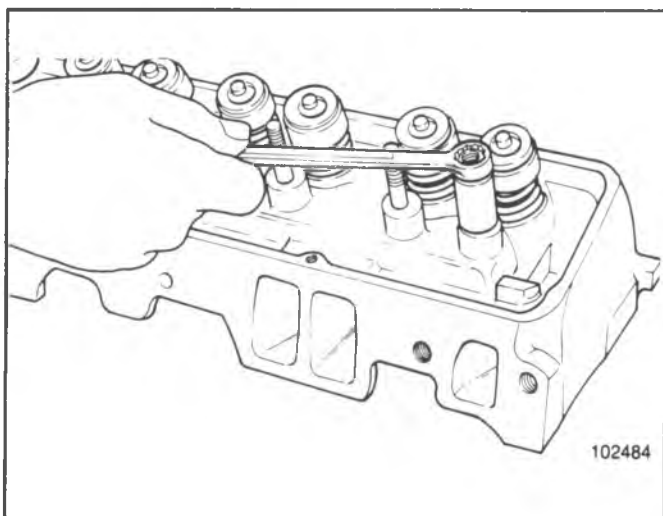

Fig. 6A1-18--Removing Rocker Arm Stud - Typical

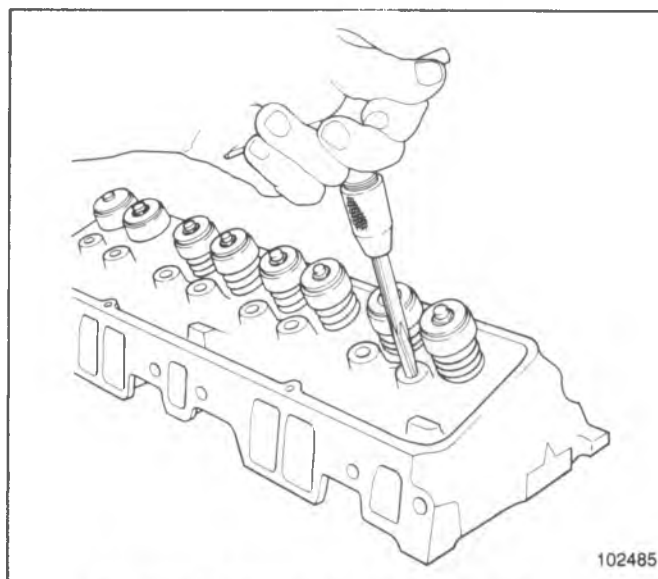

Fig. 6A1-19--Reaming Rocker Arm Stud Bore - Typical

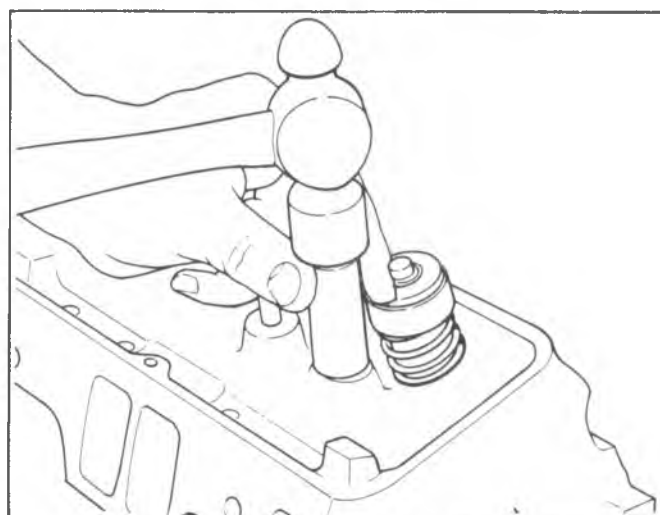

Fig. 6A1-20--Installing Rocker Arm Stud - Typical

1. Remove old stud by placing Tool J-5802-A over the stud, installing nut and flat washer and removing stud by turning nut (fig. 6A1-18).
2. Ream hole for oversize stud using Tool J-5715 for .003" oversize or Tool J-6036 for .013" oversize (fig. 6A1-19).

**NOTICE:** Do not attempt to install an oversize stud without reaming stud hole as this could damage the casting.

3. Coat press-fit area of stud with hypoid axle lubricant. Install new stud, using Tool J-6880 as a guide. Gage should bottom on head (fig. 6A1-20).

### VALVE GUIDE BORES

Valves with oversize stems are available (see specifications). To ream the valve guide bores for oversize valves, use Tool Set J-5830.

## VALVE SEATS

Reconditioning the valve seats is very important, because the seating of the valves must be perfect for the engine to deliver the power and performance built into it.

Another important factor is the cooling of the valve heads. Good contact between each valve and its seat in the head is imperative to insure that the heat in the valve head will be properly carried away.

Several different types of equipment are available for reseating valve seats. The recommendations of the manufacturer of the equipment being used should be carefully followed to attain proper results.

Regardless of what type of equipment is used, however, it is essential that valve guide bores be free from carbon or dirt to ensure proper centering of pilot in the guide.

## VALVES

Several different types of equipment are available for refacing valves. The recommendations of the manufacturer of the equipment being used should be carefully followed to attain proper results.

Valves that are pitted on the seating face can be ground at the proper angle to retain correct head to valve stem and face relationship.

When a valve head which is warped excessively is refaced, a knife edge will be ground on part or all of the valve head due to the amount of metal that must be removed to completely reface. Knife edges lead to breakage, burning or pre-ignition due to heat localizing on this knife edge. If the edge of the valve head is less than 1/32" (.80 mm) thick after grinding, replace the valve.

Valve stems which show excessive wear, or valves that are warped excessively should be replaced.

## TORSIONAL DAMPER

### Removal

1. Drain radiator and remove.
2. Remove accessory drive belt(s) and pulley (if so equipped).
3. Remove drive pulley from torsional damper.
4. Install Tool J-23523 to damper and turn puller screw to remove damper (fig. 6A1-21).

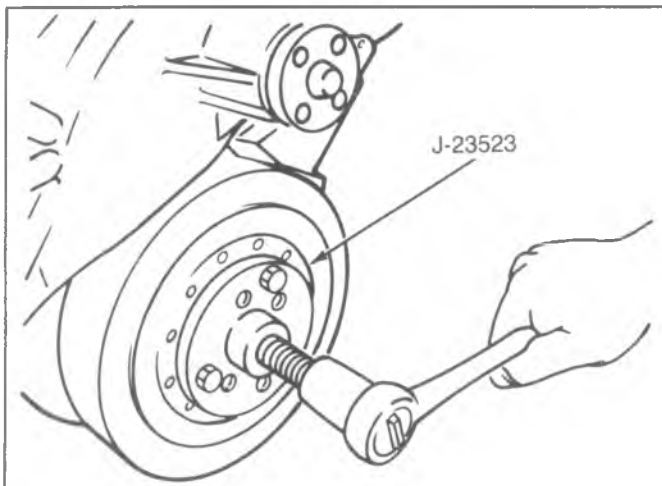

Fig. 6A1-21--Removing Torsional Damper

### Installation

1. Coat front cover oil seal contact area of damper with engine oil. Add small amount of sealant to keyway.

**NOTICE:** It is necessary to use installer Tool J-22197 to prevent the inertia weight section from walking off the hub during installation of damper.

The damper on the L25 engine should be pulled on by using special tool J-23523 or equivalent.

2. Attach damper installer Tool J-22197 to damper. Tighten fingers of tool to prevent weight from moving.
3. Position damper on crankshaft and drive into position, using J-5590 until it bottoms against crankshaft gear. Remove installer tool.
4. Install drive pulley on torsional damper (if so equipped).
5. Install accessory drive belt(s) and adjust using strand tension gage.
6. Install radiator.
7. Fill cooling system and check for leaks.

## CRANKCASE FRONT COVER (TIMING GEAR COVER)

### Removal (without removing oil pan)

1. Remove torsional damper as previously outlined.
2. Remove the oil pan-to-front cover attaching screws.
3. Remove the front cover-to-block attaching screws.
4. On L25 engine only proceed as follows:
  - a. Pull the cover slightly forward only enough to permit cutting of oil pan front seal.
  - b. Using a sharp knife or other suitable cutting tool, cut oil pan front seal flush with cylinder block at both sides of cover.
  - c. Remove front cover and attached portion of oil pan front seal. Remove front cover gasket. LE3 engine uses RTV for oil pan sealing. There is no front rubber seal.

### Installation

1. Clean gasket surfaces on block and crankcase front cover.
2. Cut tabs from the new oil pan front seal (fig. 6A1-22) use a sharp instrument to ensure a clean cut (L25 engine only).

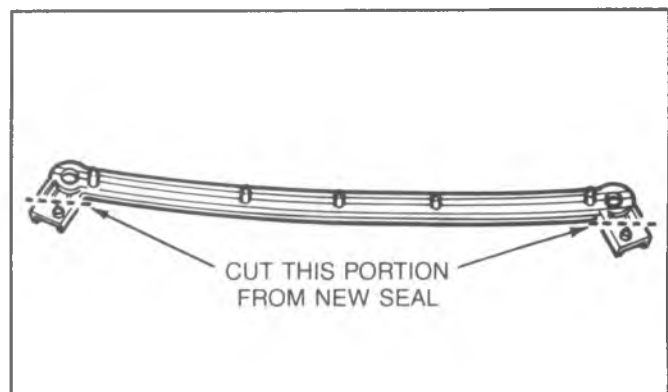

Fig. 6A1-22--Oil Pan Front Seal Modification - L25

3. Install seal to front cover, pressing tips into holes provided in cover.  
On LE3 engine, place a 3/16" (5mm) diameter bead of RTV on cover sealing surface.
4. Coat the gasket with gasket sealer and place in position on cover.
5. Apply a 1/8" (3mm) bead of RTV sealant, #1052366 or equivalent, to the joint formed at the oil pan and cylinder block.
6. Install centering Tool J-23042 in crankcase front cover seal.

**NOTICE:** It is important that centering tool be used to align crankcase front cover so that torsional damper installation will not damage seal and so that seal is positioned evenly around damper hub.

7. Install crankcase front cover to block. Install and partially tighten the two, oil pan-to-front cover screws.
8. Install the front cover-to-block attaching screws.
9. Remove centering Tool J-23042 and torque all cover attaching screws to 80 lb. in. (9N·m).
10. Install torsional damper as outlined.

## OIL SEAL (FRONT COVER)

### Replacement

#### With Cover Installed

1. With torsional damper removed, pry old seal out of cover from the front with a large screw driver, being careful not to damage the seal surface on the cover.
2. Install new seal so that open end of seal is toward the inside of cover and drive it into position with Tool J-23042.

#### With Cover Removed

1. With cover removed, pry old seal out of cover from the front with screw driver, being careful not to distort cover.
2. Install new seal so that open end of the seal is toward the inside of cover and drive it into position with Tool J-23042.

## CAMSHAFT

### Measuring Lobe Lift

1. Remove valve mechanism as previously outlined.
2. Position indicator with ball socket adapter (Tool J-8520) on push rod (fig. 6A1-23).
3. Rotate the crankshaft slowly in the direction of rotation until the lifter is on the heel of the cam lobe. At this point, the push rod will be in its lowest position.
4. Set dial indicator on zero, then rotate the crankshaft slowly, or attach an auxiliary starter switch and "bump" the engine over, until the push rod is in the fully raised position. Disconnect the coil primary lead before cranking.
5. Compare the total lift recorded from the dial indicator with specifications.
6. Continue to rotate the crankshaft until the indicator reads zero. This will be a check on the accuracy of the original indicator reading.

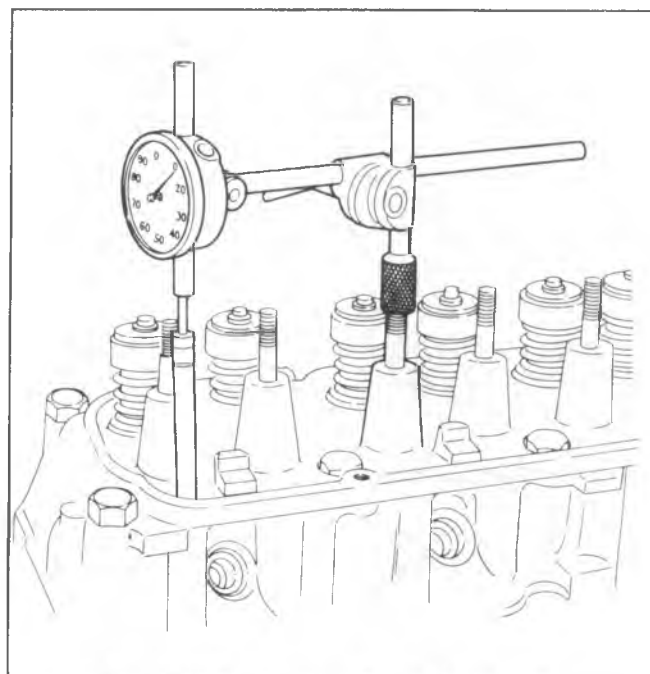

Fig. 6A1-23--Measuring Camshaft Lobe Lift

7. If camshaft readings for all lobes are within specifications, remove dial indicator assembly.
8. Install and adjust valve mechanism as outlined.

### Removal

1. Remove engine following procedure in this section.
2. Remove lifters as previously outlined.
3. Remove crankcase front cover as previously outlined.
4. Remove fuel pump.
5. Align timing gear marks then remove the two camshaft thrust plate bolts by working through holes in camshaft gear.
6. Remove the camshaft and gear assembly by pulling it out through the front of the block. Support camshaft carefully when removing so as not to damage the camshaft bearings.

### Inspection

The camshaft bearing journals should be measured with a micrometer for an out-of-round condition. If the journals exceed .001" out-of-round, the camshaft should be replaced.

Inspect the camshaft gear and thrust plate for wear or damage. Measure the camshaft end play. This should be .001" to .005".

### Gear Replacement

1. If the inspection indicated that the camshaft, gear or thrust plate should be replaced, the gear must be removed from the camshaft. This operation requires the use of camshaft gear remover J-971.
2. Place the camshaft through the gear remover, place end of remover on table of a press and press shaft out of gear.

**NOTICE:** Thrust plate must be positioned so that woodruff key in shaft does not damage it when the shaft

is pressed out of gear. Also support the hub of the gear or the gear will be seriously damaged.

3. To assemble camshaft gear thrust plate and gear spacer ring to camshaft firmly support camshaft at back of front journal in an arbor press.
4. Place gear spacer ring and thrust plate over end of shaft, and install woodruff key in shaft keyway. Install camshaft gear and press it onto the shaft until it bottoms against the gear spacer ring. The end clearance of the thrust plate should be .001" to .005".

### Installation

When a new camshaft is installed, coat camshaft lobes with GM E.O.S. or equivalent, also change oil and oil filter. Replacement of all valve lifters is recommended.

1. Install the camshaft and gear assembly in the engine block, being careful not to damage camshaft bearings or camshaft.
2. Turn crankshaft and camshaft so that the valve timing marks on the gear teeth will line up. Push camshaft into position. Install camshaft thrust plate-to-block bolts and torque to 80 lb. in. (9N·m).
3. Check camshaft and crankshaft gear run out with a dial indicator. The camshaft gear run out should not exceed .004" and the crankshaft gear run out should not exceed .003".
4. If gear run out is excessive, the gear will have to be removed and any burrs cleaned from the shaft or the gear will have to be replaced.
5. Check the backlash between the timing gear teeth with a dial indicator. The backlash should be not less than .004" nor more than .006" for new parts and not more than .008" for worn parts.
6. Install fuel pump.
7. Install crankcase front cover.
8. Install lifters.
9. Install engine in vehicle.

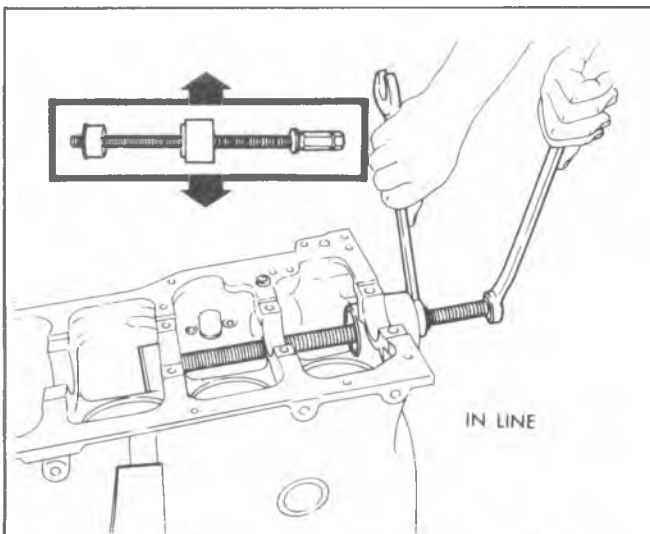

Fig. 6A1-24—Replacing Camshaft Intermediate Bearings

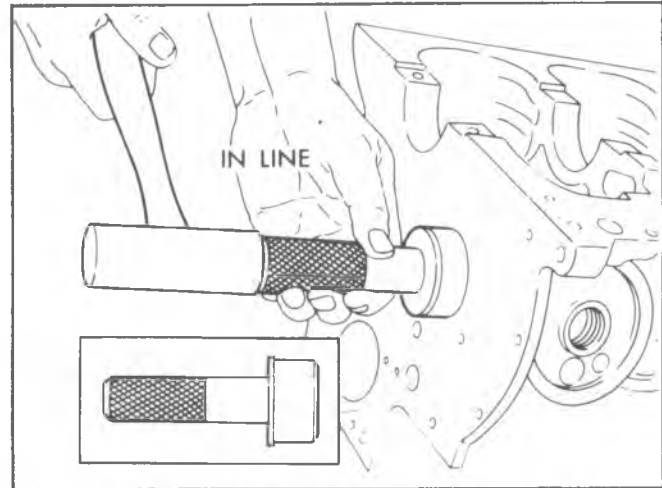

Fig. 6A1-25—Replacing Camshaft Front Bearing

## CAMSHAFT BEARINGS

### Removal

1. Remove camshaft as previously outlined.
2. Remove oil pan and oil pump as described in this section.
3. Drive camshaft rear plug from cylinder block.
4. Using Tool Set J-6098, with nut and thrust washer installed to end of threads, index pilot in camshaft front bearing and install puller screw through pilot.
5. Install remover and installer tool with shoulder toward bearing, making sure a sufficient amount of threads are engaged.
6. Using two wrenches, hold puller screw while turning nut. When bearing has been pulled from bore, remove remover and installer tool and bearing from puller screw (fig. 6A1-24).
7. Remove remaining bearings (except front and rear) in the same manner. It will be necessary to index pilot in camshaft rear bearing to remove the rear intermediate bearing.
8. Assemble remover and installer tool on driver handle and remove camshaft front and rear bearings by driving towards center of cylinder block (fig. 6A1-25).

### Installation

The camshaft front and rear bearings should be installed first. These bearings will act as guides for the pilot and center the remaining bearings being pulled into place.

1. Assemble remover and installer tool on driver handle and install camshaft front and rear bearings by driving towards center of cylinder block (fig. 6A1-25).
2. Using Tool Set J-6098, with nut and thrust washer installed to end of threads, index pilot in camshaft front bearings and install puller screw through pilot.
3. Index camshaft bearing in bore, then install remover and installer tool on puller screw with shoulder toward bearing.

**NOTICE:** All cam bearing oil holes must be aligned with oil holes in cam bore to prevent oil starvation and subsequent failure.

4. Using two wrenches, hold puller screw while turning nut. After bearing has been pulled into bore, remove the remover and installer tool from puller screw and check alignment of oil hole in camshaft bearing.
5. Install remaining bearings in the same manner. It will be necessary to index pilot in the camshaft rear bearing to install the rear intermediate bearing.
6. Install a new camshaft rear plug flush to 1/32" (.80mm) deep and parallel with rear surface of cylinder block.

## OIL PAN

### All except 'G' Van

#### Removal

1. Disconnect battery negative cable.
2. Raise vehicle and drain engine oil.
3. Remove starter.
4. Remove flywheel splash shield or converter housing underpan, as applicable.
5. Remove "through" bolts from engine front mounts.
6. Raise front of engine, reinstall mount "through" bolts and lower engine.
7. Remove oil pan bolts.
8. Remove oil pan.

#### Installation

1. Thoroughly clean all gasket sealing surfaces.
2. Using a new gasket, install rear seal in rear main bearing cap.
3. Install front seal on crankcase front cover, pressing tips into holes provided in cover.
4. Install side gaskets to engine block, using a gasket sealant with sufficient body to act as a retainer.
5. Install oil pan, torquing the retaining bolts to 80 lb. in. (9N·m).
6. Raise engine sufficiently to allow removal of "through" bolts - lower engine and install mount "through" bolts. Torque bolts to 75 lb. ft. (100 N·m).
7. Install flywheel splash shield or converter housing underpan, as applicable.
8. Install starter.
9. Lower vehicle and fill crankcase with oil. (See Owner's Manual)
10. Connect battery negative cable, start engine and check for leaks.

### "G" Van

#### Removal

1. Disconnect battery negative cable.
2. Remove engine cover.
3. Remove air cleaner and studs.
4. Remove fan finger guard.
5. Remove radiator upper support brackets.
6. Raise vehicle.
  - If vehicle is equipped with a standard transmission, perform the following steps before continuing.
    - a. Disconnect clutch cross shaft from left front mount bracket.

- b. Remove transmission to bell housing upper bolt.
- c. Remove transmission rear mount bolts and install two 7/16" x 3" bolts.
- d. Raise transmission using jack and install 2" (51mm) block between mount and crossmember.
7. Remove starter and lay aside. Detach positive battery cable from oil pan studs.
8. Drain crankcase.
9. Remove mount "through" bolts.
10. Raise engine sufficiently to insert wooden blocks between engine mounts and cross member brackets.
11. Remove flywheel splash shield or converter cover, as applicable.
12. Remove oil pan fasteners.
13. Remove oil pan and clean gasket surfaces.

#### Installation

1. Install new gasket on cleaned gasket surface.
2. Install oil pan and retaining fasteners and torque to specifications. Attach positive battery cable to oil pan studs. Torque nuts.
3. Install flywheel splash shield or converter cover, as applicable.
4. Raise engine sufficiently to remove wooden blocks, lower engine and install mount "through" bolts. Torque bolts to specification.
5. Install starter.
  - If vehicle is equipped with a standard transmission, perform the following steps.
    - a. Raise transmission using jack and remove 2" (51mm) block from between mount and cross member.
    - b. Lower transmission on cross member, remove two 7/16" x 3" bolts, install rear mount bolts and torque to specifications.
    - c. Install transmission to bell housing upper bolt.
    - d. Connect clutch cross shaft to left front mount bracket.
6. Lower vehicle on hoist.
7. Install radiator upper support brackets.
8. Install fan finger guard.
9. Install air cleaner studs and air cleaner.
10. Install engine cover.
11. Fill crankcase with oil. (See Owner's Manual).
12. Connect battery negative cable, start engine and check for leaks.

## OIL PUMP

#### Removal

1. Remove oil pan as previously outlined.
2. Remove two flange mounting bolts, pickup pipe bolt, then remove pump and screen as an assembly.

#### Disassembly

1. Remove the pump cover attaching screws, the pump cover and the pump cover gasket (fig. 6A1-26).
2. Mark gear teeth so they may be reassembled with the same teeth indexing. Remove the idler gear and the drive gear and shaft from the pump body.

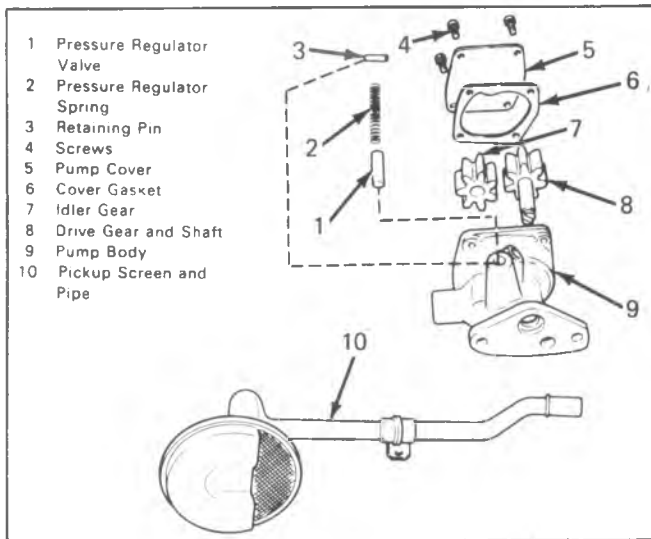

Fig. 6A1-26--Oil Pump

3. Remove the pressure regulator valve retaining pin, pressure regulator valve and related parts.
4. If the pickup screen and pipe assembly need replacing, mount the pump in a soft-jawed vise and extract pipe from pump.  
Do not disturb the pickup screen on the pipe. This is serviced as an assembly.

#### Cleaning and Inspection

1. Wash all parts in cleaning solvent and dry with compressed air.
2. Inspect the pump body and cover for cracks or excessive wear.
3. Inspect pump gears for damage or excessive wear.
4. Check the drive gear shaft for looseness in the pump body.
5. Inspect inside of pump cover for wear that would permit oil to leak past the ends of the gears.
6. Inspect the pickup screen and pipe assembly for damage to screen, pipe or relief grommet.
7. Check the pressure regulator valve for fit.

The pump gears and body are not serviced separately. If the pump gears or body are damaged or worn, replacement of the entire oil pump assembly is necessary.

#### Assembly

1. If the pickup screen and pipe assembly was removed, it should be replaced with a new part. Loss of press fit condition could result in an air leak and loss of oil pressure. Mount the pump in a soft-jawed vise, apply sealer to the end of pipe and tap the pipe in place with a plastic hammer using Tool J-8369.
- NOTICE:** Be careful of twisting, shearing or collapsing pipe while installing in pump. Pickup screen must be parallel to bottom of oil pan when oil pump is installed.
2. Install the pressure regulator valve and related parts.
3. Install the drive gear and shaft in the pump body.
4. Install the idler gear in the pump body with the smooth side of gear towards pump cover opening.
5. Install the pump cover, with new gasket, and torque attaching screws to 70 lb. in. (8N·m).
6. Turn drive shaft by hand to check for smooth operation.

#### CONNECTING ROD BEARINGS

Connecting rod bearings are of the precision insert type and do not utilize shims for adjustment. **DO NOT FILE RODS OR ROD CAPS.** If clearances are found to be excessive a new bearing will be required. Service bearings are available in standard size and .001" and .002" undersize for use with new and used standard size crankshafts, and in .010" and .020" undersize for use with reconditioned crankshafts.

On removing a connecting rod cap, it is possible to find a .009" undersize bearing. These are used in manufacturing for selective fitting.

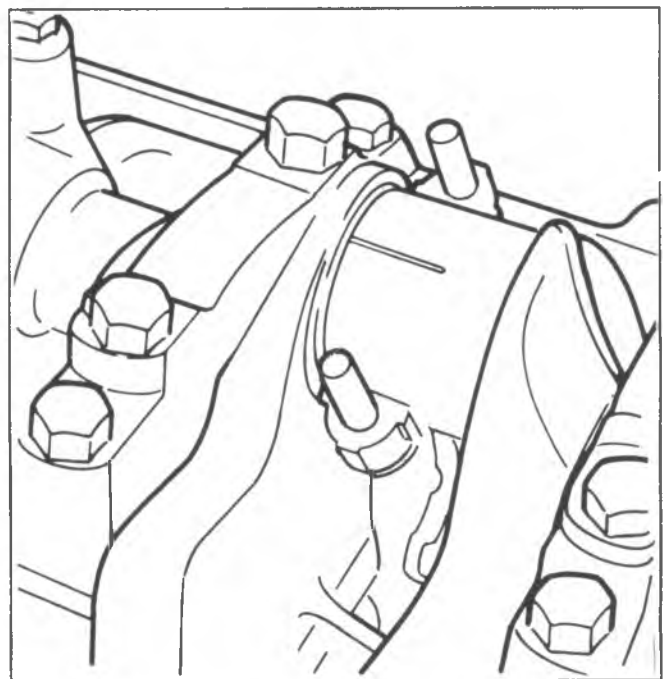

Fig. 6A1-27--Gaging Plastic on Crankpin



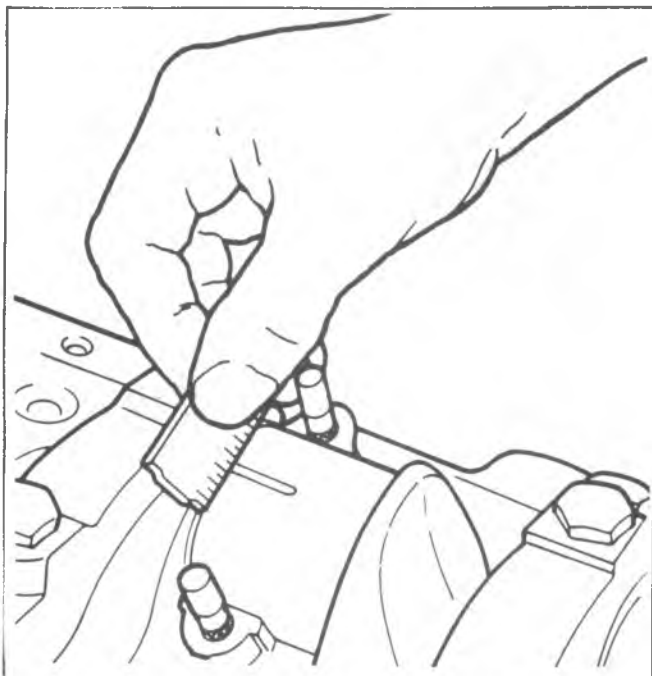

Fig. 6A1-28--Measuring Gaging Plastic

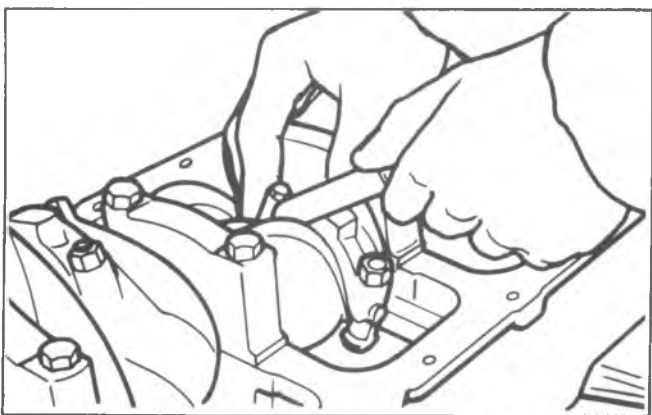

Fig. 6A1-29--Measuring Connecting Rod Side Clearance

### Inspection and Replacement

1. With oil pan and oil pump removed, remove the connecting rod cap and bearing.  
Before removal of connecting rod cap, mark the side of the rod and cap with the cylinder number to assure matched reassembly of rod and cap.
2. Inspect the bearings for evidence of wear or damage. (Bearings showing the above should not be installed.)
3. Wipe both upper and lower bearing shells and crankpin clean of oil.
4. Measure the crankpin for out-of-round or taper with a micrometer. If not within specifications replace or recondition the crankshaft. If within specifications and a new bearing is to be installed, measure the maximum diameter of the crankpin to determine new bearing size required.
5. If within specifications measure new or used bearing clearances with Plastigage or its equivalent.  
If a bearing is being fitted to an out-of-round crankpin, be sure to fit to the maximum diameter of the crankpin.

If the bearing is fitted to the minimum diameter and the crankpin is out-of-round .001" interference between the bearing and crankpin will result in rapid bearing failure.

- a. Place a piece of gaging plastic, the length of the bearing (parallel to the crankshaft), on the crankpin or bearing surface (fig. 6A1-27). Plastic gage should be positioned in the middle of upper or lower bearing shell. (Bearings are eccentric and false readings could occur if placed elsewhere).
  - b. Install the bearing in the connecting rod and cap.
  - c. Install the bearing cap and evenly torque nuts to 35 lb. ft. (47N·m).  
Do not turn the crankshaft with the gaging plastic installed.
  - d. Remove the bearing cap and using the scale on the gaging plastic envelope, measure the gaging plastic width at the widest point (fig. 6A1-28).
6. If the clearance exceeds specifications, select a new, correct size, bearing and remeasure the clearance.  
Be sure to check what size bearing is being removed in order to determine proper replacement size bearing. Undersize is marked on the back of the bearing. If clearance cannot be brought within specification, the crankpin will have to be ground undersize. If the crankpin is already at maximum undersize, replace crankshaft.
  7. Coat the bearing surface with oil, install the rod cap and torque nuts to 35 lb. ft. (47N·m).
  8. When all connecting rod bearings have been installed, tap each rod lightly (parallel to the crankpin) to make sure they have clearance.
  9. Measure all connecting rod side clearances between the connecting rod cap and side of crankpin (fig. 6A1-29).

### CRANKSHAFT MAIN BEARINGS

Main bearings are of the precision insert type and do not utilize shim for adjustment. If clearances are found to be excessive, a new bearing, both upper and lower halves, will be required. Service bearings are available in standard size and .001", .002", .009", .010" and .020" undersize.

Selective fitting of both rod and main bearing inserts is necessary in production in order to obtain close tolerances. For this reason you may find one half of a standard insert with one half of a .001" undersize insert which will decrease the clearance .0005" from using a full standard bearing.

When a production crankshaft cannot be precision fitted by this method, it is then ground .009" undersize **on only those main journals that cannot be properly fitted. All journals will not necessarily be ground.** A .009" undersize bearing or .010" undersize bearing will then be used for precision fitting in the same manner as previously described.

A reground crankshaft will be identified by the following:

- The crankshaft throw will be stamped on one side of the undersize journal with "9", along with a large spot of light green paint.
- The main bearing cap will be painted light green on each side of the affected.  
If, for any reason, main bearings caps are replaced, shimming may be necessary. Laminated shims for each



cap are available for service. Shim requirement will be determined by bearing clearance.

### Inspection

In general, the lower half of the bearing (except #1 bearing) shows a greater wear and the most distress from fatigue. If upon inspection the lower half is suitable for use, it can be assumed that the upper half is also satisfactory. If the lower half shows evidence of wear or damage, both upper and lower halves should be replaced. **Never replace one half without replacing the other half.**

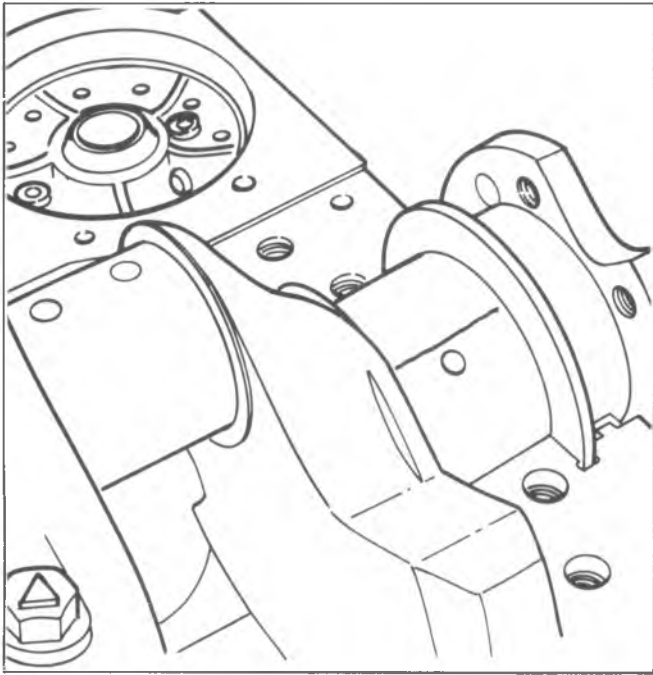

Fig. 6A1-30--Gaging Plastic on Journal - Typical

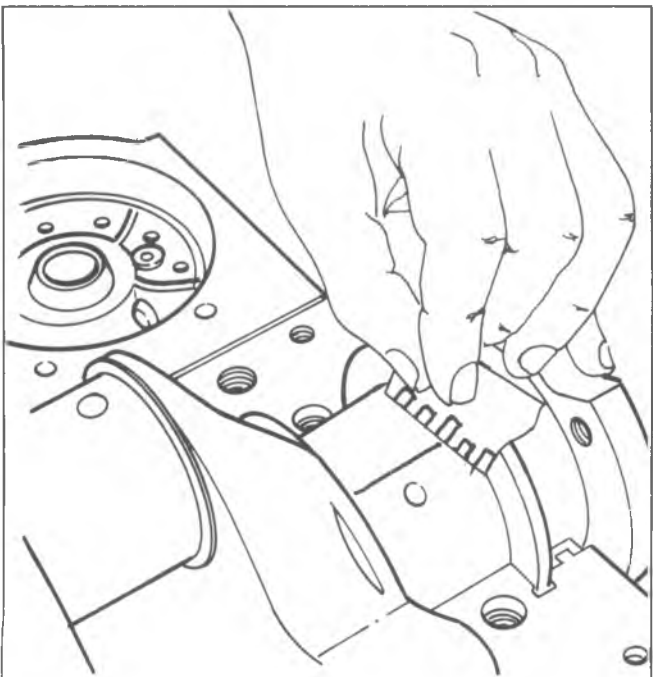

Fig. 6A1-31--Measuring Gaging Plastic - Typical

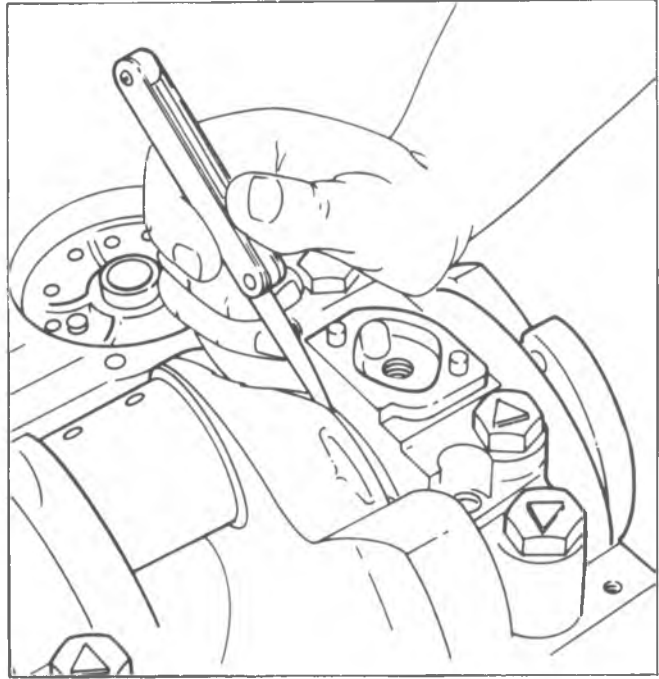

Fig. 6A1-32--Measuring Crankshaft End Play - Typical

### Checking Clearance

To obtain the most accurate results with "Plastigage", or its equivalent, a wax-like plastic material which will compress evenly between the bearing and journal surfaces without damaging either surface, certain precautions should be observed. If the engine is out of the vehicle and upside down, the crankshaft will rest on the upper bearings and the total clearance can be measured between the lower bearing and journal. If the engine is to remain in the vehicle, the crankshaft must be supported upward to remove any clearance from the upper bearing. The total clearance can then be measured between the lower bearing and journal.

To assure the proper seating of the crankshaft all bearing cap bolts must be at their specified torque. In addition, preparatory to checking fit of bearings, the surface of the crankshaft journal and bearing must be wiped clean of oil.

1. With the oil pan and oil pump removed, and starting with the rear main bearing, remove bearing cap and wipe oil from journal, both bearing shells and bearing cap.
2. Place a piece of gaging plastic the full width of the bearing (parallel to the crankshaft) on the journal (fig. 6A1-30).  
Do not rotate the crankshaft while the gaging plastic is between the bearing and journal.
3. Install the bearing cap and evenly torque the retaining bolts to 65 lb. ft. (88N·m). Bearing cap **MUST** be torqued to specification in order to assure proper reading. Variations in torque affect the compression of the plastic gage.
4. Remove bearing cap. The flattened gaging plastic will be found adhering to either the bearing shell or journal.
5. On the edge of gaging plastic envelope there is a graduated scale which is correlated in thousandths of an inch. Without removing the gaging plastic, measure its compressed width, **at the widest point**, with the

graduations on the gaging plastic envelope (fig. 6A1-31).

Normally, main bearing journals wear evenly and are not out-of-round. However, if a bearing is being fitted to an out-of-round journal (.001" max.), be sure to fit to the maximum diameter of the journal. If the bearing is fitted to the minimum diameter and the journal is out-of-round .001", interference between the bearing and journal will result in rapid bearing failure. If the flattened gaging plastic tapers toward the middle or ends, there is a difference in clearance indicating taper, low spot or other irregularity of the bearing or journal. Be sure to measure the journal with a micrometer if the flattened gaging plastic indicates more than .001" difference.

6. If the bearing clearance is within specifications, the bearing insert is satisfactory. If the clearance is not within specifications, replace the insert. Always replace both upper and lower insert as a unit.  
If a new bearing cap is being installed and clearance is less than .001", inspect for burrs or nicks; if none are found then install shims as required.
7. A standard, .001" or .002" undersize bearing may produce the proper clearance. If not, it will be necessary to regrind the crankshaft journal for use with the next undersize bearing.  
After selecting new bearing, recheck clearance.
8. Proceed to the next bearing. After all bearings have been checked, rotate the crankshaft to see that there is no excessive drag.  
When checking #1 main bearing, loosen accessory drive belts so as to prevent tapered reading with plastic gage.
9. Measure crankshaft end play (see specifications) by forcing the crankshaft to the extreme front position. Measure at the front end of the rear main bearing with a feeler gage (fig. 6A1-32).
10. Install a new rear main bearing oil seal in the cylinder block and main bearing cap.

### Replacement

Main bearings may be replaced with or without removing the crankshaft.

#### With Crankshaft Removed

1. Remove and inspect the crankshaft.
2. Remove the main bearings from the cylinder block and main bearing caps.
3. Coat bearing surfaces of new, correct size, main bearings with oil and install in the cylinder block and main bearing caps.
4. Install the crankshaft.

#### Without Crankshaft Removal

1. With oil pan, oil pump and spark plugs removed, remove cap on main bearing requiring replacement and remove bearing from cap.
2. The rear main journal has no oil hole. Replace the rear main bearing upper half as follows:
  - a. Use a small drift punch and hammer to start the upper bearing half rotating out of block.

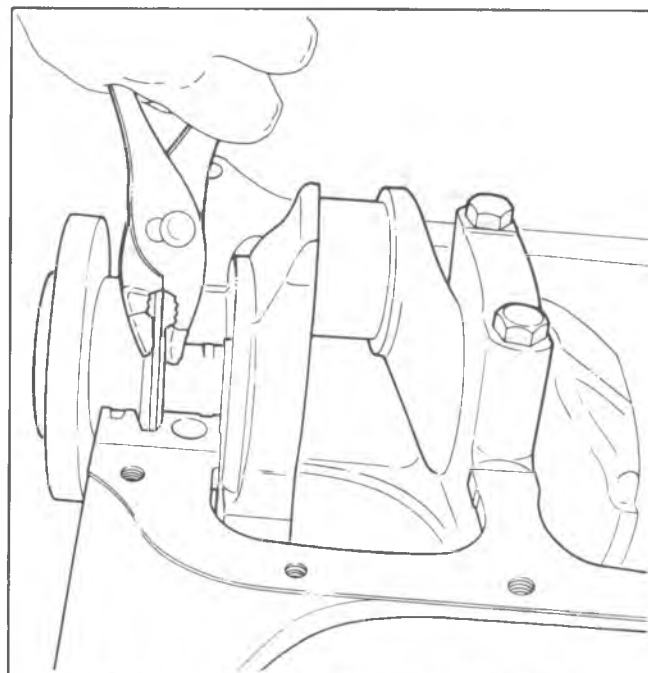

Fig. 6A1-33--Replacing Upper Main Bearing

- b. Use a pair of pliers (with taped jaws) to hold the bearing thrust surface to the oil slinger and rotate the crankshaft to remove bearing (fig. 6A1-33).
  - c. Oil new selected size upper bearing and insert plain (unnotched) end between crankshaft and indented or notched side of block.
  - d. Use pliers as in removing to rotate bearing into place. The last 1/4" (6.5mm) movement may be done by holding just the slinger with the pliers or tap in place with a drift punch.
3. All other crankshaft journals have oil holes. Replace the main bearing upper half as follows:
    - a. Install a main bearing removing and installing tool, such as Tool J-8080, in oil hole in crankshaft journal. If such a tool is not available, a cotter pin may be bent as required to do the job.
    - b. Rotate the crankshaft clockwise as viewed from the front of engine. This will roll upper bearing out of block.
    - c. Oil new selected size upper bearing and insert plain (unnotched) end between crankshaft and indented or notched side of block. Rotate the bearing into place and remove tool from oil hole in crankshaft journal.
  4. Oil new lower bearing and install in bearing cap.
  5. Install main bearing caps with arrows pointing toward front of engine.
  6. Torque all main bearing caps **except the rear main cap** to 65 lb. ft. (88N·m). Torque rear main bearing cap to 10-12 lb. ft. (14-16N·m) then tap end of crankshaft, first rearward then forward with a lead hammer. This will line up rear main bearing and crankshaft thrust surfaces. Retorque **all** main bearing cap bolts to 65 lb. ft. (88N·m).

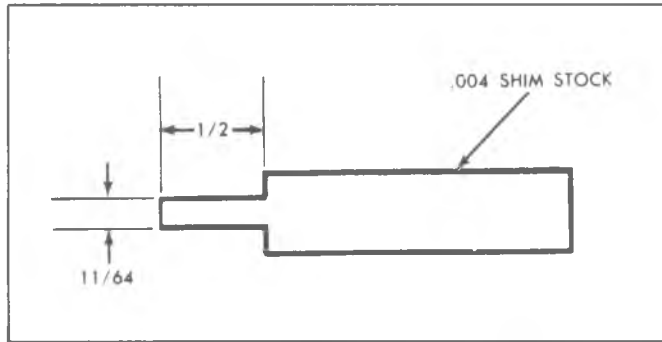

Fig. 6A1-34--Oil Seal Installation Tool

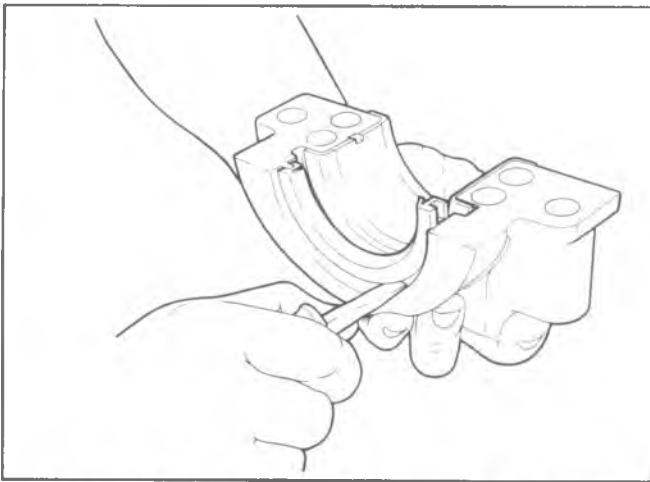

Fig. 6A1-35--Removing Oil Seal Lower Half - Typical

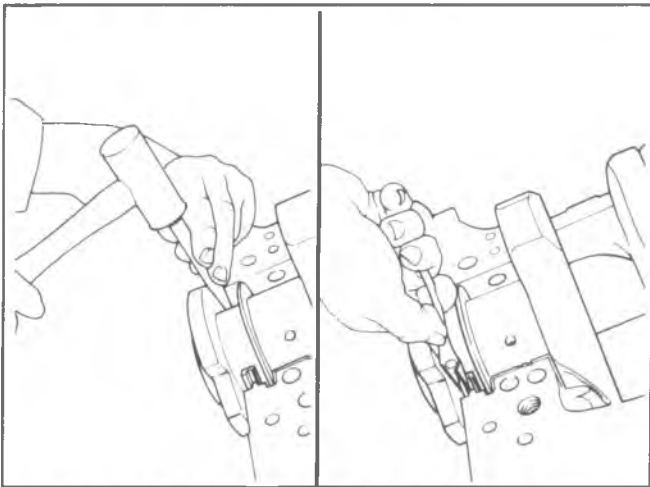

Fig. 6A1-36--Removing Oil Seal Upper Half - Typical

## OIL SEAL (REAR MAIN)

### Replacement

The rear main bearing oil seal can be replaced (both halves) without removal of the crankshaft. Always replace the upper and lower seal as a unit. Install seal with lip facing front of engine. Extreme care should be exercised when installing this seal to protect the sealing bead located in the channel on the outside diameter of the seal. An installation tool (fig. 6A1-34) can be used to protect the seal bead when positioning seal as follows:

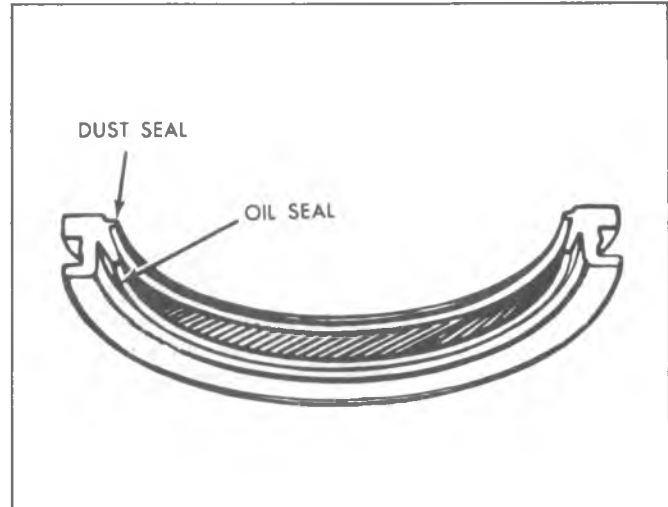

Fig. 6A1-37--Crankshaft Oil Seal - Rear Main

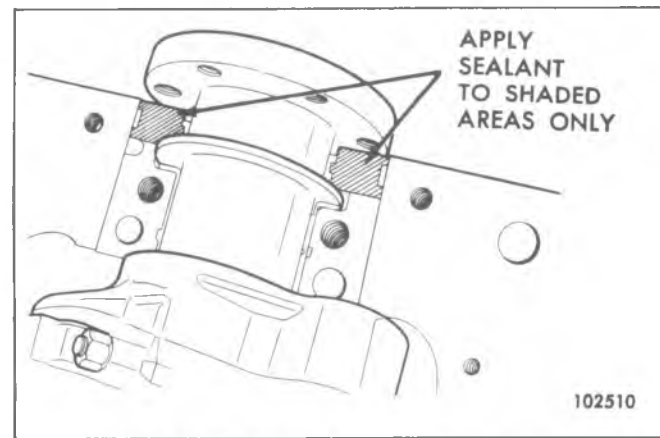

Fig. 6A1-38--Sealing Bearing Cap - Typical

1. With the oil pan and oil pump removed, remove the rear main bearing cap.
2. Remove oil seal from the bearing cap by prying from the bottom with a small screw driver (fig. 6A1-35).
3. Use a small hammer to tap a brass pin punch on one end of the upper seal until it protrudes far enough to be removed with pliers (fig. 6A1-36).
4. Clean all sealant and foreign material from cylinder case bearing cap and crankshaft, using a nonabrasive cleaner.
5. Inspect components for nicks, scratches, burrs and machining defects at all sealing surfaces, case assembly and crankshaft.
6. Coat seal lips and seal bead with light engine oil - keep oil off seal mating ends.
7. Position tip of tool between crankshaft and seal seat in cylinder case.
8. Position seal between crankshaft and tip of tool so that seal bead contacts tip of tool. Make sure that oil-seal lip is positioned toward front of engine (fig. 6A1-37).
9. Roll seal around crankshaft using tool as a "shoe-horn" to protect seal bead from sharp corner of seal seat surface in cylinder case. Installation tool must remain in position until seal is properly positioned with both ends flush with block.

10. Remove tool, being careful not to withdraw seal.
11. Install seal half in bearing cap, again using tool as a "shoe-horn", feeding seal into cap using light pressure with thumb and finger.
12. Install bearing cap to case with sealant applied to the cap-to-case interface being careful to keep sealant off the seal split line (fig. 6A1-38).
13. Install the rear main bearing cap (with new seal) and torque to 10-12 lb. ft. (14-16 N·m). Tap end of crankshaft first rearward then forward with a lead hammer. This will line up rear main bearing and crankshaft thrust surfaces. Retorque bearing cap to 65 lb. ft. (88N·m).

## PISTON AND CONNECTING ROD ASSEMBLIES

### Removal

1. Remove oil pan, oil pump and cylinder head as previously outlined.
2. For the cylinder being serviced, turn crankshaft until piston is at the bottom of the stroke. Place a cloth on top of the piston.
3. Use a ridge reamer to remove any ridge and/or deposits from the upper end of the cylinder bore.
4. Turn crankshaft until piston is at top of stroke and remove cloth and cuttings.
5. Remove connecting rod cap and install Tool J-6305 (11/32") on studs. Push connecting rod and piston assembly out of top of cylinder block (fig. 6A1-39). It will be necessary to turn the crankshaft slightly to disconnect some of the connecting rod and piston assemblies and push them out of the cylinder.

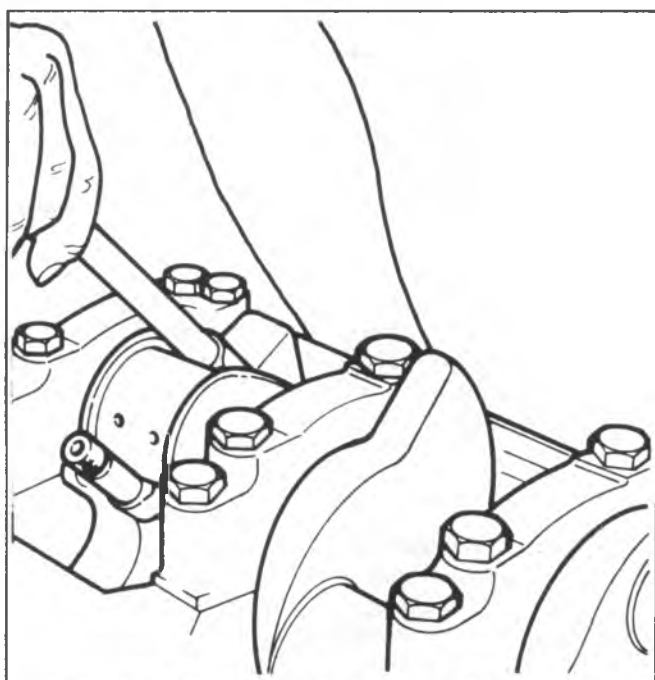

Fig. 6A1-39--Removing Connecting Rod & Piston Assembly

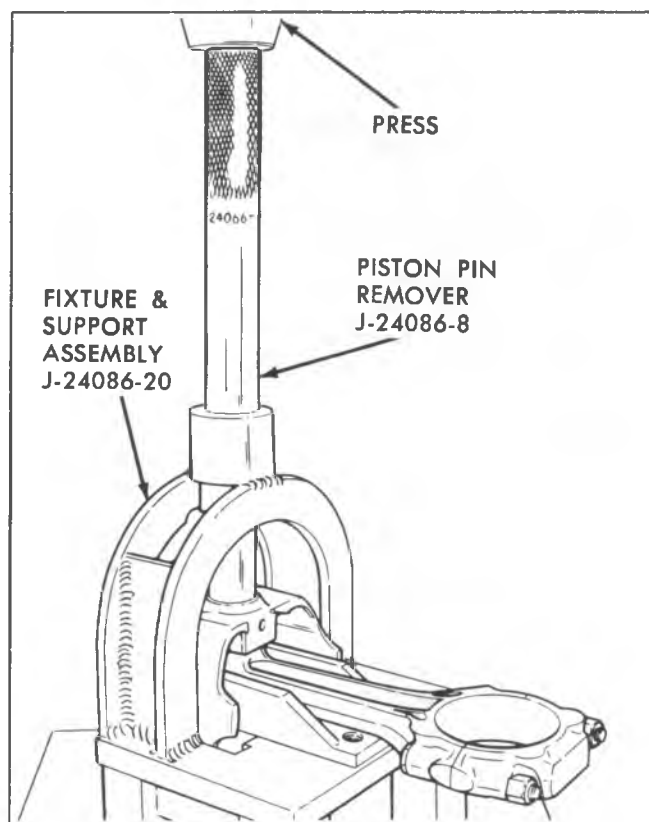

Fig. 6A1-40--Removing Piston Pin

### Disassembly

1. Remove connecting rod bearings from connecting rods and caps. If bearings are being reused, place them in a rack so they may be reinstalled in their original positions.
2. Remove piston rings by expanding and sliding them off the pistons. Tools J-8021 (3-7/8") and J-22249 (3-15/16") are available for this purpose.
3. Place connecting rod and piston assembly on tool J-24086-20. Using an arbor press and piston pin remover, J-24086-8, press the piston pin out of connecting rod and piston (fig. 6A1-40).

### Cleaning and Inspection

#### Connecting Rods

Wash connecting rods in cleaning solvent and dry with compressed air.

Check for twisted or bent rods and inspect for nicks or cracks. Replace connecting rods that are damaged.

#### Pistons

Clean varnish from piston skirts and pins with a cleaning solvent. **DO NOT WIRE BRUSH ANY PART OF THE PISTON.** Clean the ring grooves with a groove cleaner and make sure oil ring holes and slots are clean.

Inspect the piston for cracked ring lands, skirts or pin bosses, wavy or worn ring lands, scuffed or damaged skirts, eroded areas at top of the piston. Replace pistons that are damaged or show signs of excessive wear.

Inspect the grooves for nicks or burrs that might cause the rings to hang up.

Measure piston skirt (across center line of piston pin) and check clearance.

### Piston Pins

The piston pin clearance is designed to maintain adequate clearance under all engine operating conditions. Because of this, the piston and piston pin are a matched set and not serviced separately.

Inspect piston pin bores and piston pins for wear. Piston pin bores and piston pins must be free of varnish or scuffing when being measured. The piston pin should be measured with a micrometer and the piston pin bore should be measured with a dial bore gage or an inside micrometer. If clearance is in excess of the .001" wear limit, the piston and piston pin assembly should be replaced.

### ASSEMBLY

1. Lubricate piston pin holes in piston and connecting rod to facilitate installation of pin.
2. Place connecting rod in piston and hold in place with piston pin guide and piston pin. Place connecting rod and piston assembly on fixture and support assembly.
3. Using piston pin installer, J-24086-9, press the piston pin into the piston and connecting rod (Fig. 6A1-41). Make sure installer is set properly (see tool instructions).

**NOTICE:** After installer hub bottoms on support assembly, do not exceed 5000 psi pressure, as this could cause structural damage to the tool.

4. Remove piston and connecting rod assembly from tool and check piston for freedom of movement on piston pin.

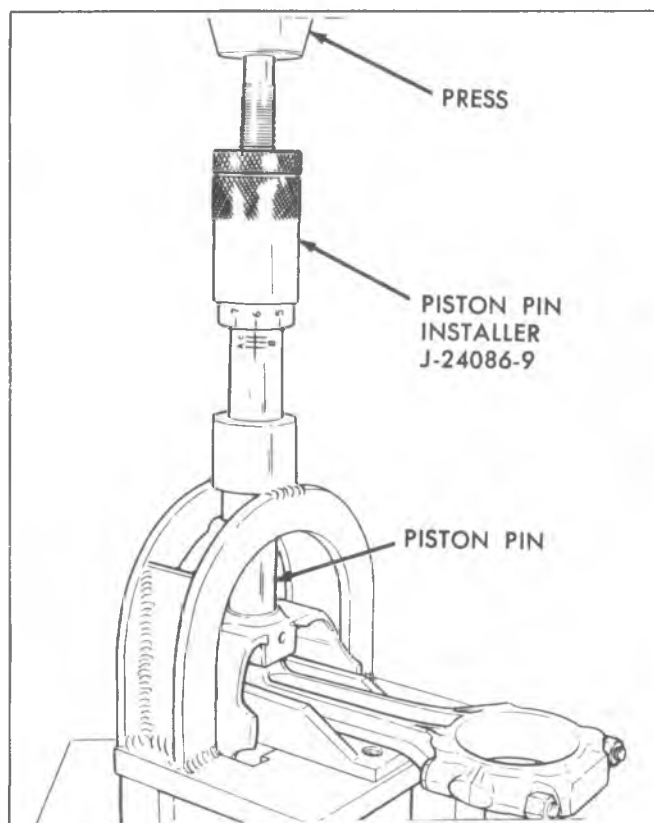

Fig. 6A1-41--Installing Piston Pin

### Piston Rings

All compression rings are marked on the upper side of the ring. When installing compression rings, make sure the marked side is toward the top of the piston. The top ring is chrome faced, or treated with molybdenum for maximum life.

The oil control rings are of three piece type, consisting of two segments (rails) and a spacer.

1. Select rings comparable in size to the piston being used.
2. Slip the compression ring in the cylinder bore; then press the ring down into the cylinder bore about 1/4" (6.5mm) (above ring travel). Be sure ring is square with cylinder wall.
3. Measure the space or gap between the ends of the ring with a feeler gage.
4. If the gap between the ends of the ring is below specifications, remove the ring and try another for fit.
5. Fit each compression ring to the cylinder in which it is going to be used.
6. If the pistons have not been cleaned and inspected as previously outlined, do so.
7. Slip the outer surface of the top and second compression ring into the respective piston ring groove and roll the ring entirely around the groove to make sure that the ring is free. If binding occurs at any point the cause should be determined, and if caused by ring groove, remove by dressing with a fine cut file. If the binding is caused by a distorted ring, check a new ring.
8. Install piston rings as follows (fig. 6A1-42):
  - a. Install oil ring spacer in groove and insert anti-rotation tang in oil hole.
  - b. Hold spacer ends butted and install lower steel oil ring rail with gap properly located.
  - c. Install upper steel oil ring rail with gap properly located.
  - d. Flex the oil ring assembly to make sure ring is free. If binding occurs at any point, the cause should be determined, and if caused by ring groove, remove by dressing groove with a fine cut file. If binding is caused by a distorted ring, check a new ring.
  - e. Install second compression ring expander then ring with gaps properly located.
  - f. Install top compression ring with gap properly located.
9. Proper clearance of the piston ring in its piston ring groove is very important to provide proper ring action and reduce wear. Therefore, when fitting new rings, the clearances between the surfaces of the ring groove should be measured (fig. 6A1-43). (See Specifications.)

### Installation

Cylinder bores must be clean before piston installation. This may be accomplished with a hot water and detergent wash or with a light honing as necessary. After cleaning, the bores should be swabbed several times with light engine oil and a clean dry cloth.

1. Lubricate connecting rod bearings and install in rods and rod caps.

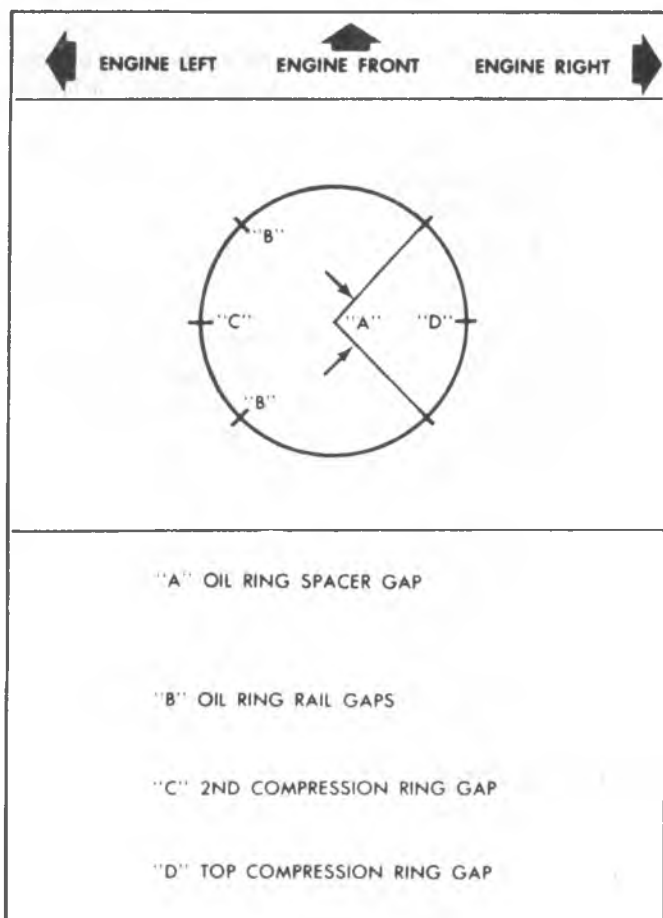

Fig. 6A1-42--Ring Gap Location

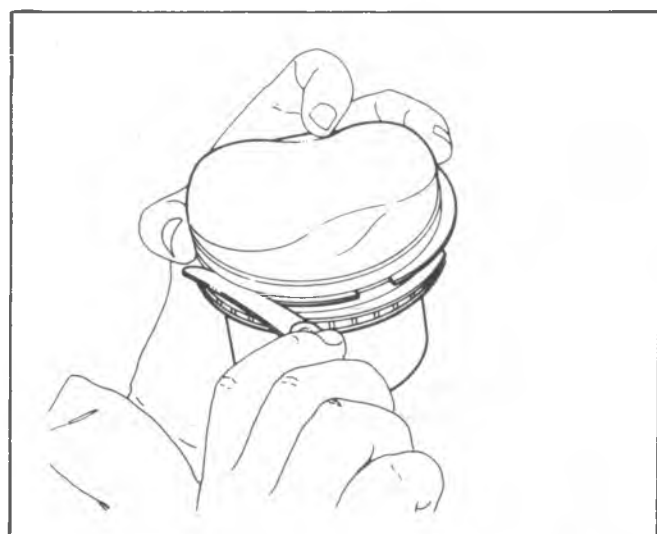

Fig. 6A1-43--Measuring Ring Groove Clearance

2. Lightly coat pistons, rings and cylinder walls with light engine oil.
3. With bearing caps removed, install Tool J-6305 (11/32") on connecting rod bolts.

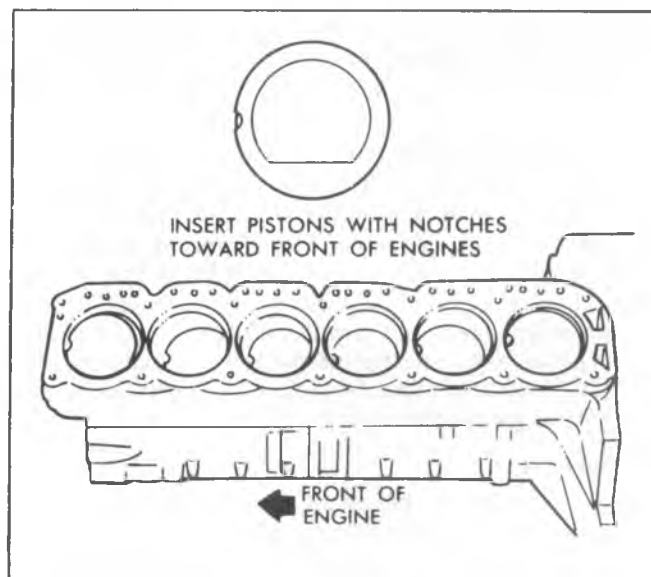

Fig. 6A1-44--Pistons-Installed Position

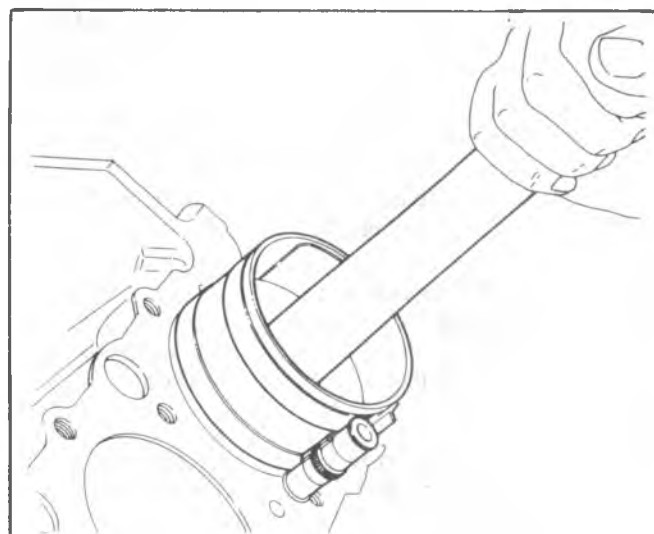

Fig. 6A1-45--Installing Connecting Rod and Piston Assembly

4. Install each connecting rod and piston in its respective bore. Pistons must have notches facing front of engine (fig. 6A1-44). Use Tool J-8037 to compress the rings (fig. 6A1-45). Guide the connecting rod into place on the crankshaft journal with Tool J-6305 (11/32"). Use a hammer handle and light blows to install the piston into the bore. Hold the ring compressor firmly against the cylinder block until all piston rings have entered the cylinder bore.
5. Remove J-6305.
6. Install the bearing caps and torque nuts to 35 lb. ft. (47N·m).

## CYLINDER BLOCK

### Cleaning and Inspection

1. Wash cylinder block thoroughly in cleaning solvent and clean all sealing surfaces.

2. Remove oil gallery plugs and clean all oil passages.
3. Clean and inspect water passages in the cylinder block.
4. Inspect the cylinder block for cracks in the cylinder walls, water jacket, valve lifter bores and main bearing webs.
5. Measure the cylinder walls for taper, out-of-round or excessive ridge at top of ring travel. This should be done with a dial indicator. Set the gage so that the thrust pin must be forced in about 1/4" (6.5mm) to enter gage in cylinder bore. Center gage in cylinder and turn dial to "O". Carefully work gage up and down cylinder to determine taper and turn it to different points around cylinder wall to determine the out-of-round condition. If cylinders were found to exceed specifications, honing or boring will be necessary.

### Conditioning

The performance of the following operation is contingent upon engine condition at time of repair.

If the cylinder block inspection indicated that the block was suitable for continued use except for out-of-round or tapered cylinders, they can be conditioned by honing or boring.

If the cylinders were found to have less than .005" taper or wear they can be conditioned with a hone and fitted with the high limit standard size piston. A cylinder bore of less than .005" wear or taper may not entirely clean up when fitted to a high limit piston. If it is desired to entirely clean up the bore in these cases, it will be necessary to rebore for an oversize piston. If more than .005" taper or wear, they should be bored and honed to the smallest oversize that will permit complete resurfacing of all cylinders.

When pistons are being fitted and honing is not necessary, cylinder bores may be cleaned with a hot water and detergent wash. After cleaning, the cylinder bores should be swabbed several times with light engine oil and a clean cloth and then wiped with a clean dry cloth.

### Boring

1. Before using any type boring bar, the top of the cylinder block should be filed to remove any dirt or burrs. This is very important. If not checked, the boring bar may be tilted which would result in the rebored cylinder wall not being at right angles to the crankshaft.
2. The piston to be fitted should be measured with a micrometer, measuring at the center of the piston skirt and at right angles to the piston pin. The cylinder should be bored to the same diameter as the piston and honed to give the specified clearance.
3. The instructions furnished by the manufacturer of the equipment being used should be carefully followed.

### Honing

1. When cylinders are to be honed follow the hone manufacturer's recommendations for the use of the hone and cleaning and lubrication during honing.
2. Occasionally during the honing operation, the cylinder bore should be thoroughly cleaned and the piston selected for the individual cylinder checked for correct fit.
3. When finish honing a cylinder bore to fit a piston, the hone should be moved up and down at a sufficient speed

to obtain very fine uniform surface finish marks in a cross-hatch pattern of approximately 45 to 65° included angle. The finish marks should be clean but not sharp, free from imbedded particles and torn or folded metal.

4. Permanently mark the piston for the cylinder to which it has been fitted and proceed to hone cylinders and fit the remaining pistons.

**NOTICE:** Handle the pistons with care and do not attempt to force them through the cylinder until the cylinder has been honed to correct size as this type piston can be distorted through careless handling.

5. Thoroughly clean the bores with hot water and detergent. Scrub well with a stiff bristle brush and rinse thoroughly with hot water. It is extremely essential that a good cleaning operation be performed. If any of the abrasive material is allowed to remain in the cylinder bores, it will rapidly wear the new rings and cylinder bores in addition to the bearings lubricated by the contaminated oil. The bores should be swabbed several times with light engine oil and a clean cloth and then wiped with a clean dry cloth. Cylinders should not be cleaned with kerosene or gasoline. Clean the remainder of the cylinder block to remove the excess material spread during the honing operation.

### PISTON SELECTION

1. Check USED piston to cylinder bore clearance as follows:
  - a. Measure the "Cylinder Bore Diameter" with a telescope gage (2-1/2" (64mm) from top of cylinder bore).
  - b. Measure the "Piston Diameter" (at skirt across center line of piston pin).
  - c. Subtract piston diameter from cylinder bore diameter to determine "Piston to Bore Clearance".
  - d. Determine if piston to bore clearance is in the acceptable range.
2. If used piston is not acceptable, determine if a new piston can be fitted to the cylinder bore.
3. If cylinder bore must be reconditioned, measure new piston diameter (across center line of piston pin) then hone cylinder bore to correct clearance.
4. Mark the piston to identify the cylinder for which it was fitted.

### FLYWHEEL

#### Removal

#### All Except L25 Engines

1. Remove transmission and/or clutch housing and clutch from engine.
2. Remove flywheel retaining bolts and remove flywheel.

#### L25 Engines

1. Remove transmission and/or clutch housing and clutch from engine.
2. Mark relationship of flywheel and crankshaft so that dowel holes can be aligned in their original positions on assembly.
3. Remove engine oil pan and rear main bearing cap.



4. Remove flywheel retaining bolts and drive crankshaft dowels out of flywheel and crankshaft. Rotate crankshaft as necessary so dowels clear cylinder block.
5. Remove flywheel and discard used dowel pins.

### Repair

Only repair recommended at flywheel used with conventional clutch is replacement of starter gear in event gear is worn or otherwise damaged.

Use torch to heat the gear around entire circumference, then drive the gear off flywheel, using care not to damage the flywheel.

Uniformly heat the flywheel gear to temperature which will expand gear to permit installation. [Temperature must not exceed 400°F (204°C)].

As soon as gear has been heated, install on flywheel.

**NOTICE: NEVER HEAT STARTER GEAR TO RED HEAT AS THIS WILL CHANGE METAL STRUCTURE.**

### Installation

#### All Except L25 Engines

1. Clean the mating surfaces of flywheel and crankshaft to make certain there are no burrs.
2. Install flywheel on crankshaft and position to align dowel hole of crankshaft flange and flywheel.
3. Install flywheel retaining bolts and torque to specifications.

#### L25 Engine

1. Clean the mating surfaces of flywheel and crankshaft to make certain there are no burrs.
2. Install flywheel on crankshaft and position to align dowel holes of crankshaft flange and flywheel.
3. Install flywheel retaining bolts and torque to specifications.
  - The interference fit dowel pins used on 4.8 L (T) engines must be replaced with an oversize dowel pin when installing the flywheel.
4. When installing the original flywheel, ream the dowel pin holes with Tool J-22808-2. When installing a new flywheel, first ream the dowel pin holes with Tool J-22808-2 and then finish reaming them with Tool J-22808-1.
5. Install oversize dowel pins flush with flywheel retaining bolt surface.
6. Install rear main bearing cap and torque bolts to specifications. Install oil pan with new gaskets and seals. Torque oil pan retaining screws to specifications.

## ENGINE ASSEMBLY

### Removal ("G" Van/Code D Engine)

1. Disconnect battery negative cable at battery.
2. Drain cooling system.
3. Remove engine cover.
4. Remove air cleaner.
5. If equipped, evacuate A/C system and remove A/C compressor.
6. Disconnect accelerator linkage at carburetor and remove carburetor from manifold.

7. Remove grille and grille cross brace.
8. Remove windshield washer jar and, if equipped, A/C vacuum reservoir.
9. Disconnect radiator hoses from radiator.
10. Remove radiator to radiator support attaching brackets and remove radiator.
  - If equipped with automatic transmission, remove cooler lines from radiator before attempting removal.
  - If equipped with A/C, remove condenser to radiator support attaching bolts and swing condenser to the side, out of the way.
11. Remove heater hoses from engine.
12. Disconnect all necessary wiring from engine:
  - Generator
  - Distributor
  - All sending switches
  - Starter
13. Raise vehicle.
14. Remove fuel line hose from suction side of fuel pump.
15. Drain crankcase.
16. Remove propshaft and plug end of transmission.
17. Remove exhaust pipe from manifold flange.
18. Remove linkage from transmission and disconnect speedometer cable.
19. Remove transmission mount bolts.
  - If equipped with manual transmission, disconnect clutch linkage and remove clutch cross shaft.
20. Remove engine mount "through" bolts.
21. Lower vehicle.
22. Attach lifting devise to engine.
23. Raise engine slightly and remove right hand mount assembly from engine.
24. Remove engine/transmission assembly.

### Installation ("G" Van/Code D Engine)

1. Place engine/transmission assembly into vehicle.
2. Install right hand engine mount assembly and lower engine onto mounts.
3. Remove lifting tool.
4. Raise vehicle and install engine mount "through" bolts. Torque to specifications.
5. Install transmission mount bolts. Torque to specifications.
6. Connect transmission shift linkage and speedometer cable.
  - If equipped with manual transmission, connect clutch linkage and install clutch cross shaft.
7. Attach exhaust pipe to manifold flange.
8. Install propshaft.
9. Connect fuel tank line to fuel pump.
10. Lower vehicle.
11. Connect all wiring to engine components:
  - Generator
  - Distributor
  - All sending units
  - Starter



12. Connect heater hoses to engine.
13. Install radiator and hold in place with radiator to support attaching brackets.
  - If equipped with Automatic Transmission, connect cooler lines to radiator.
  - If equipped with A/C, install condenser in front of radiator. Bolt to radiator support.
14. Connect radiator hoses to radiator.
15. Install windshield washer jar and, if equipped, A/C vacuum reservoir.
16. Install grille cross brace and grille.
17. Using a new pad gasket, install carburetor. Connect accelerator linkage.
18. If equipped, mount A/C compressor.
19. Fill crankcase with oil.
20. Fill cooling system.
21. Connect battery negative cable and start engine. Check ignition timing and adjust carburetor if necessary.
22. Install air cleaner and engine cover.

#### Removal (CK Series/Code D & T Engines)

1. Disconnect battery cables at battery.
2. Remove air cleaner.
3. Drain cooling system.
4. Disconnect accelerator cable from carburetor throttle lever.
  - If equipped with automatic transmission, remove detent cable from carburetor throttle lever.
5. Disconnect all wiring from engine.
6. Remove radiator hoses from radiator.
7. Remove heater hoses from engine.
8. Remove radiator.
9. Remove fan and water pump pulley.
10. Disconnect fuel line from fuel pump.
11. Remove vehicle hood.
12. Raise vehicle.
13. Remove starter.
14. Remove flywheel or torque converter splash shield, as applicable.
15. Disconnect exhaust pipe from exhaust manifold flange. Wire up and out of way.
16. Remove engine mount 'through' bolts.
  - If equipped with automatic transmission, remove converter to flex plate bolts.
  - If 'K' model, remove strut rods at motor mounts.
17. Remove bell housing to engine retaining bolts. Support transmission with chain.
18. Lower vehicle.
19. Attach engine lifting device.
20. Remove engine.

#### Installation (CK Series/Code D & T Engines)

1. Place engine in vehicle.
2. Raise vehicle.
3. Install bell housing to engine retaining bolts. Torque to specifications.

- If equipped with automatic transmission, install torque converter to flex plate attaching bolts. Torque to specifications.
4. Install engine mount to frame retaining bolts. Torque to specifications.
  5. Connect exhaust pipe to exhaust manifold flange.
  6. Install flywheel or torque converter splash shield, as applicable.
  7. Install starter. Torque bolts to specifications.
  8. Lower vehicle.
  9. Attach fuel line to fuel pump.
  10. Install water pump pulley and fan. Torque bolts to specifications.
  11. Install radiator.
  12. Connect heater hoses to engine.
  13. Connect radiator hoses to radiator.
  14. Connect all wiring to engine.
  15. Connect accelerator cable to carburetor throttle lever.
    - If equipped with automatic transmission, connect detent cable to throttle lever.
  16. Fill cooling system.
  17. Fill crankcase with oil.
  18. Install vehicle hood.
  19. Connect battery cables, start engine. Check timing and carburetor adjustment. Adjust if necessary.
  20. Install air cleaner.

## CRANKSHAFT

### Removal

1. Remove engine as previously outlined. Remove clutch, if applicable, and flywheel and mount engine on stand.
2. Remove the oil dipstick and oil dipstick tube.
3. Remove the spark plugs.
4. Remove crankshaft pulley and torsional damper.
5. Remove oil pan and oil pump.
6. Remove crankcase front cover.
7. Remove the connecting rod caps and push the pistons to the top of bores.
8. Remove main bearing caps and lift crankshaft out of cylinder block.
9. Remove rear main bearing oil seal and main bearings from cylinder block and main bearing caps.

### Cleaning and Inspection

1. Wash crankshaft in solvent and dry with compressed air.
2. Measure dimensions of main bearing journals and crankpins with a micrometer for out-of-round, taper or undersize. (See Specifications.)
3. Check crankshaft for run-out by supporting the front and rear main bearing journals in "V" blocks and check at the front and rear intermediate journals with a dial indicator. (See Specifications.)
4. Replace or recondition the crankshaft if out of specifications.

### Installation

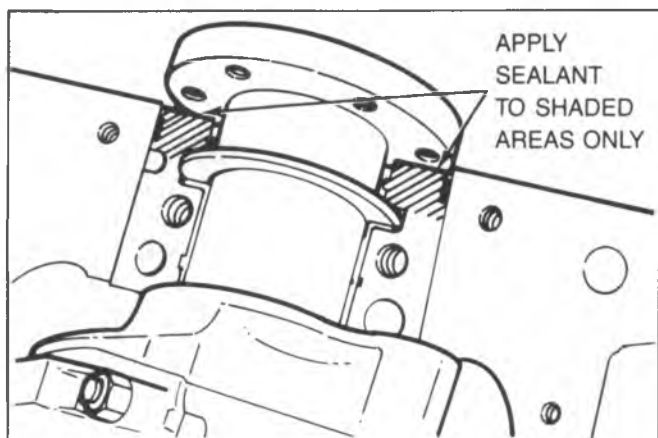

Fig. 6A1-46--Sealing Bearing Cap

1. Install rear main bearing oil seal in cylinder block and rear main bearing cap grooves. Install with lip of seal toward front of engine. Install lip and helix towards front of engine.
2. Lubricate lips of seal with engine oil. Keep oil off parting line surface.
3. Install main bearings in cylinder block and main bearing caps then lubricate bearing surface with engine oil.
4. Install crankshaft, being careful not to damage bearing surfaces.

5. Apply a thin coat of brush-on type oil sealing compound to block mating surface and corresponding surface of cap only (fig. 6A1-46). Do not allow sealer on crankshaft or seal.
6. Install main bearing caps with arrows pointing toward front of engine.
7. Torque all except rear main bearing cap bolts to specifications. Torque rear main bearing cap bolts to 10-12 lbs. ft. (14-16 N·m) then tap end of crankshaft, first rearward then forward with a lead hammer. This will line up rear main bearing and crankshaft thrust surfaces. Retorque all main bearing cap bolts to specifications.
8. Measure crankshaft end play with a feeler gage. Force crankshaft forward and measure clearance between the front of the rear main bearing and the crankshaft thrust surface.
9. Install flywheel and torque to specifications. Align dowel hole in flywheel with dowel hole in crankshaft.
  - On vehicles equipped with automatic transmissions, install flywheel with the converter attaching pads towards transmission.

#### Gear Replacement

Remove crankshaft gear using Tool J-8105 and install using Tool J-5590 (fig. 6A1-47).

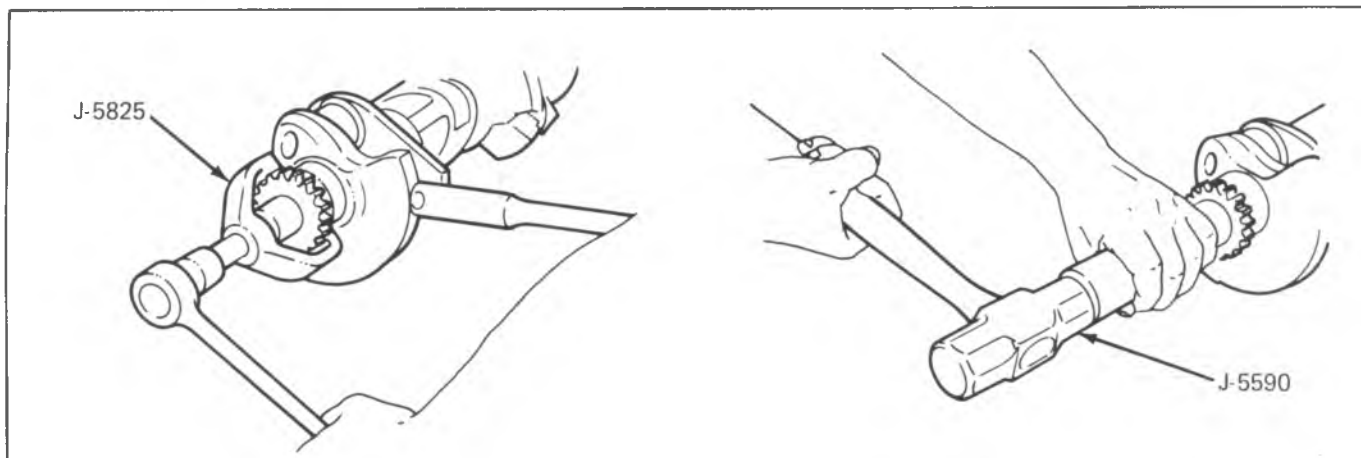

Fig. 6A1-47--Gear Replacement

GENERAL DATA:

|                   |           |             |         |
|-------------------|-----------|-------------|---------|
| TYPE              |           | IN LINE L-6 |         |
| DISPLACEMENT      | LITRE (*) | 4.1 (D)     | 4.8 (T) |
| RPO               |           | LE3         | L25     |
| BORE              |           | 3.876       |         |
| STROKE            |           | 3.530       | 4.120   |
| COMPRESSION RATIO |           | 8.25:1      | 8.0:1   |
| FIRING ORDER      |           | 1-5-3-6-2-4 |         |

CYLINDER BORE:

|              |            |               |            |
|--------------|------------|---------------|------------|
| DIAMETER     |            | 3.8750-3.8780 |            |
| OUT OF ROUND | PRODUCTION | .0005 MAX.    |            |
|              | SERVICE    | .002 MAX.     |            |
| TAPER        | PRODUCTION | THRUST SIDE   | .0005 MAX. |
|              |            | RELIEF SIDE   | .0005 MAX. |
|              | SERVICE    | .001 MAX.     |            |

PISTON:

|           |            |             |             |
|-----------|------------|-------------|-------------|
| CLEARANCE | PRODUCTION | .0010-.0020 | .0026-.0036 |
|           | SERVICE    | .0030 MAX.  | .0045 MAX.  |

PISTON RING:

|             |                  |            |                 |             |             |
|-------------|------------------|------------|-----------------|-------------|-------------|
| COMPRESSION | GROOVE CLEARANCE | PRODUCTION | TOP             | .0012-.0027 | .0020-.0040 |
|             |                  |            | 2ND             | .0012-.0032 | .0020-.0040 |
|             |                  | SERVICE    | HI LIMIT + .001 |             |             |
|             | GAP              | PRODUCTION | TOP             | .010-.020   |             |
|             |                  |            | 2ND             | .010-.020   |             |
|             |                  | SERVICE    | HI LIMIT + .010 |             |             |
| OIL         | GROOVE CLEARANCE | PRODUCTION | .005 MAX.       | .005-.0055  |             |
|             |                  | SERVICE    | HI LIMIT + .001 |             |             |
|             | GAP              | PRODUCTION | .015-.055       |             |             |
|             |                  | SERVICE    | HI LIMIT + .010 |             |             |

\* VIN Designation

PISTON PIN

LE3

L25

|            |            |                          |  |
|------------|------------|--------------------------|--|
| DIAMETER   |            | .9270-.9273              |  |
| CLEARANCE  | PRODUCTION | .00015-.00025            |  |
|            | SERVICE    | .001 MAX.                |  |
| FIT IN ROD |            | .0008-.0016 INTERFERENCE |  |

CRANKSHAFT

|                        |              |            |                                    |             |
|------------------------|--------------|------------|------------------------------------|-------------|
| MAIN JOURNAL           | DIAMETER     |            | ALL<br>2.2979-2.2994               |             |
|                        | TAPER        | PRODUCTION | .0002 MAX.                         |             |
|                        |              | SERVICE    | .001 MAX.                          |             |
|                        | OUT OF ROUND | PRODUCTION | .0002 MAX.                         |             |
| SERVICE                |              | .001 MAX.  |                                    |             |
| MAIN BEARING CLEARANCE | PRODUCTION   |            | #1-6 .0010-.0024<br>#7 .0016-.0035 |             |
|                        | SERVICE      |            | #1-6                               | .0010-.0025 |
| CRANKSHAFT END PLAY    |              |            | .002-.006                          |             |
| CRANKPIN               | DIAMETER     |            | 1.999-2.000                        | 2.099-2.100 |
|                        | TAPER        | PRODUCTION | .0005                              |             |
|                        |              | SERVICE    | .001 MAX.                          |             |
|                        | OUT OF ROUND | PRODUCTION | .0005                              |             |
| SERVICE                |              | .001 MAX.  |                                    |             |
| ROD BEARING CLEARANCE  | PRODUCTION   |            | .0010-.0026                        |             |
|                        | SERVICE      |            | .0030                              |             |
| ROD SIDE CLEARANCE     |              |            | .006-.017                          |             |

CAMSHAFT

|                     |         |  |               |              |
|---------------------|---------|--|---------------|--------------|
| LOBE LIFT<br>± .002 | INTAKE  |  | .2217         | .2315        |
|                     | EXHAUST |  | FED. .2217    | CALIF. .2315 |
| JOURNAL DIAMETER    |         |  | 1.8677-1.8697 |              |
| CAMSHAFT END PLAY   |         |  | .003-.008     |              |

SPECIFICATIONS

| VALVE SYSTEM             |                             |                              | LE3                             | L25 |
|--------------------------|-----------------------------|------------------------------|---------------------------------|-----|
| LIFTER                   |                             | HYDRAULIC                    |                                 |     |
| ROCKER ARM RATIO         |                             | 1.75:1                       |                                 |     |
| VALVE LASH               | INTAKE                      | ONE TURN DOWN FROM ZERO LASH |                                 |     |
|                          | EXHAUST                     |                              |                                 |     |
| FACE ANGLE (INT. & EXH.) |                             | 45°                          | 46°                             |     |
| SEAT ANGLE (INT. & EXH.) |                             | 46°                          |                                 |     |
| SEAT RUNOUT              |                             | .002 MAX.                    |                                 |     |
| SEAT WIDTH               | INTAKE                      | .035/.060                    |                                 |     |
|                          | EXHAUST                     | .062/.093                    |                                 |     |
| STEM CLEARANCE           | PRODUCTION                  | INT.                         | .0010-.0027                     |     |
|                          |                             | EXH.                         | .0015-.0032                     |     |
|                          | SERVICE                     | HI LIMIT                     | + .001 INTAKE<br>+ .002 EXHAUST |     |
| VALVE SPRING (OUTER)     | FREE LENGTH                 |                              | 2.08                            |     |
|                          | PRESSURE LBS. @ IN.         | CLOSED                       | 78-86 @ 1.66                    |     |
|                          |                             | OPEN                         | 170-180 @ 1.26                  |     |
|                          | INSTALLED HEIGHT<br>± 1/32" |                              | 1.66                            |     |
| DAMPER                   | FREE LENGTH                 |                              | 1.94                            |     |
|                          | APPROX. # OF COILS          |                              | 4                               |     |

## TORQUE SPECIFICATIONS

|                                 |                |
|---------------------------------|----------------|
| Camshaft Thrust Plate           | .80 lb. in.    |
| Crankshaft Front Cover          | .80 lb. in.    |
| Flywheel Housing Cover          | .80 lb. in.    |
| Oil Pan (To Crankcase) (1/4-20) | .80 lb. in.    |
| Oil Pan (To Front Cover)        | .50 lb. in.    |
| Oil Pump Cover                  | .70 lb. in.    |
| Rocker Arm Cover                | .45 lb. in.    |
| Connecting Rod Cap              | .35 lb. ft.*   |
| Clutch Pressure Plate           | .20 lb. ft.*   |
| Oil Pan (To Crankcase) 5/16-18) | .75 lb. in.    |
| Oil Pump                        | .115 lb. in.   |
| Push Rod Cover                  | .50 lb. in.    |
| Water Pump                      | .15 lb. in.    |
| Clutch Pressure Plate           | .30 lb. ft.@   |
| Distributor Clamp               | .25 lb. ft.    |
| Flywheel Housing                | .30 lb. ft.    |
| Manifold (Exhaust)              | .30 lb. ft. 2  |
| Manifold (Exhaust To Inlet)     | .45 lb. ft. 2  |
| Manifold To Head                | .40 lb. ft. 2  |
| Thermostat Housing              | .30 lb. ft.    |
| Water Outlet                    | .30 lb. ft.    |
| Connecting Rod Cap              | .40 lb. ft.@   |
| Main Bearing Cap                | .65 lb. ft.    |
| Flywheel                        | .60 lb. ft.*   |
| Torsional Damper                | .60 lb. ft.@ 1 |
| Cylinder Head                   | .95 lb. ft. 1  |
| Temperature Sending Unit        | .20 lb. ft.    |
| Oil Filter                      | Hand Tight     |
| Oil Pan Drain Plug              | .20 lb. ft.    |
| Flywheel                        | .110 lb. ft.@  |
| Spark Plug                      | .17-27 lb. ft. |

\* 4.1 (D) only

@ 4.8 (T) only

1 Except LH Front Bolt 85 lb. ft.

2 Non-Integral Head



# SMALL BLOCK ENGINES

## C-K-G TRUCKS

|   |     |   |     |     |     |     |     |            |
|---|-----|---|-----|-----|-----|-----|-----|------------|
|   | 5.0 | L | (F) | V-8 | --- | RPO | LF3 |            |
| → | 5.0 | L | (H) | V-8 | --- | RPO | LE9 | ← Bookwise |
|   | 5.7 | L | (L) | V-8 | --- | RPO | LS9 |            |
| → | 5.7 | L | (M) | V-8 | --- | RPO | LT9 | ← Reality  |

### Contents

|                              |    |                                      |    |
|------------------------------|----|--------------------------------------|----|
| General Description .....    | 1  | Crankcase Front Cover .....          | 19 |
| Engine Lubrication .....     | 2  | Oil Seal (Front Cover) .....         | 20 |
| On Vehicle Service .....     | 5  | Camshaft.....                        | 20 |
| Engine Mounts.....           | 5  | Camshaft Bearings .....              | 21 |
| Intake Manifold.....         | 5  | Oil Pan .....                        | 22 |
| Exhaust Manifold.....        | 11 | Oil Pump.....                        | 22 |
| Rocker Arm Cover .....       | 12 | Connecting Rod Bearings.....         | 23 |
| Valve Mechanism .....        | 12 | Main Bearings .....                  | 24 |
| Valve Stem Oil Seal and/or   |    | Oil Seal (Rear Main) .....           | 26 |
| Valve Spring .....           | 13 | Connecting Rod Piston Asemblies..... | 27 |
| Valve Lifters .....          | 14 | Cylinder Block.....                  | 30 |
| Cylinder Head Assembly ..... | 15 | Oil Filter Bypass Valve .....        | 31 |
| Rocker Arm Studs.....        | 18 | Engine Assembly .....                | 31 |
| Valve Guide Bores .....      | 18 | Crankshaft .....                     | 33 |
| Valve Seats .....            | 18 | Sprocket or Gear Replacement.....    | 33 |
| Valves.....                  | 18 | Specifications .....                 | 34 |
| Torsional Damper.....        | 19 |                                      |    |

## GENERAL DESCRIPTION

### CYLINDER BLOCK

The cylinder block is made of cast iron and has 8 cylinders arranged in a "V" shape with 4 cylinders in each bank. Five main bearings support the crankshaft which is retained by bearing caps that are machined with the block for proper alignment and clearances. Cylinders are completely encircled by coolant jackets.

### CYLINDER HEAD

The cylinder heads are cast with individual intake and exhaust ports for each cylinder. Valve guides are integral, and rocker arms are retained on individual studs.

### CRANKSHAFT AND BEARINGS

The crankshaft is cast nodular iron, and is supported by five main bearings. Number five bearing is the end thrust bearing.

Main bearings are lubricated from oil holes which intersect the camshaft bearings. The camshaft bearings are fed oil by the main oil gallery which is rifle drilled down the center of the block, above the camshaft. Two additional oil galleries are on either side of the main oil gallery to provide an oil supply for the hydraulic lifters.

A torsional damper on the forward end of the crankshaft dampens any engine torsional vibrations.

## **CAMSHAFT AND DRIVE**

The cast iron camshaft is supported by five bearings and is chain driven. A steel or sintered iron crankshaft gear drives the timing chain which in turn drives the camshaft through either a nylon/aluminum or cast iron gear depending on application.

Cam lobes are ground, hardened and tapered with the high side toward the rear. This, coupled with a spherical face on the lifter, causes the valve lifters to rotate.

Camshaft bearings are lubricated through oil holes which intersect the main oil gallery. The main oil gallery is rifle drilled down the center of the block, above the camshaft.

## **PISTONS AND CONNECTING RODS**

The pistons are made of cast aluminum alloy using two compression rings and one oil control ring. Piston pins are offset 1/16" (1.6mm) toward the thrust side (right hand side) to provide a gradual change in thrust pressure against the cylinder wall as the piston travels its path. Pins are Chromium steel and have a floating fit in the pistons. They are retained in the connecting rods by a press fit.

Connecting rods are made of forged steel. Full pressure lubrication is directed to the connecting rods by drilled oil passages from the adjacent main bearing journal. Oil holes at the connecting rod journals are located so that oil is supplied to give maximum lubrication just prior to full bearing load.

## **VALVE TRAIN**

A very simple ball pivot-type train is used. Motion is transmitted from the camshaft through the hydraulic lifter and push rod to the rocker arm. The rocker arm pivots on its ball and transmits the camshaft motion to the valve. The rocker-arm ball is retained by a nut.

## **HYDRAULIC VALVE LIFTERS**

Hydraulic Valve Lifters are used to keep all parts of the valve train in constant contact.

The hydraulic lifter assembly consists of: the lifter body, which rides in the cylinder block boss, a plunger, a

push rod seat, a metering valve, a plunger spring, a check ball and spring, a check ball retainer and a push rod seat retainer.

When the lifter is riding on the low point of the cam, the plunger spring keeps the plunger and push rod seat in contact with the push rod.

When the lifter body begins to ride up the cam lobe, the check ball cuts off the transfer of oil from the reservoir below the plunger. The plunger and lifter body then rise as a unit, pushing up the push rod and opening the valve.

As the lifter body rides down the other side of the cam, the plunger follows with it until the valve closes. The lifter body continues to follow the cam to its low point, but the plunger spring keeps the plunger in contact with the push rod. The ball check valve will then move off its seat and the lifter reservoir will remain full.

## **INTAKE MANIFOLD**

The intake manifold is of cast iron double level design for efficient fuel distribution. The carburetor pad is centrally located with a passage running underneath the pad (E.F.E.) through which exhaust gases are forced to promote faster fuel vaporization when the engine is cold. An EGR port is also cast into the manifold for the mixture of exhaust gases with the fuel air mixture.

## **EXHAUST MANIFOLDS**

Two cast iron exhaust manifolds are used to direct exhaust gases from the combustion chambers to the exhaust system. The right hand side manifold receives a heat stove that is used to route heated air to the air cleaner for better fuel vaporization during warmup.

## **COMBUSTION CHAMBERS**

Combustion Chambers are cast to insure uniform shape for all cylinders. Spark plugs are located between the intake and exhaust valves.

The contoured wedge shape of the combustion chamber minimizes the possibility of detonation, facilitates breathing, and provides swirling turbulence for smooth, complete combustion.

# **ENGINE LUBRICATION**

Full pressure lubrication through a full flow oil filter, is furnished by a gear-type oil pump. The distributor, driven by a helical gear on the camshaft, drives the oil pump. The main oil gallery feeds oil, through drilled passages, to the

camshaft and crankshaft to lubricate the bearings. The valve lifter oil gallery feeds the valve lifters which, through hollow push rods, feed the individually mounted rocker arms (figs. 1 and 2).

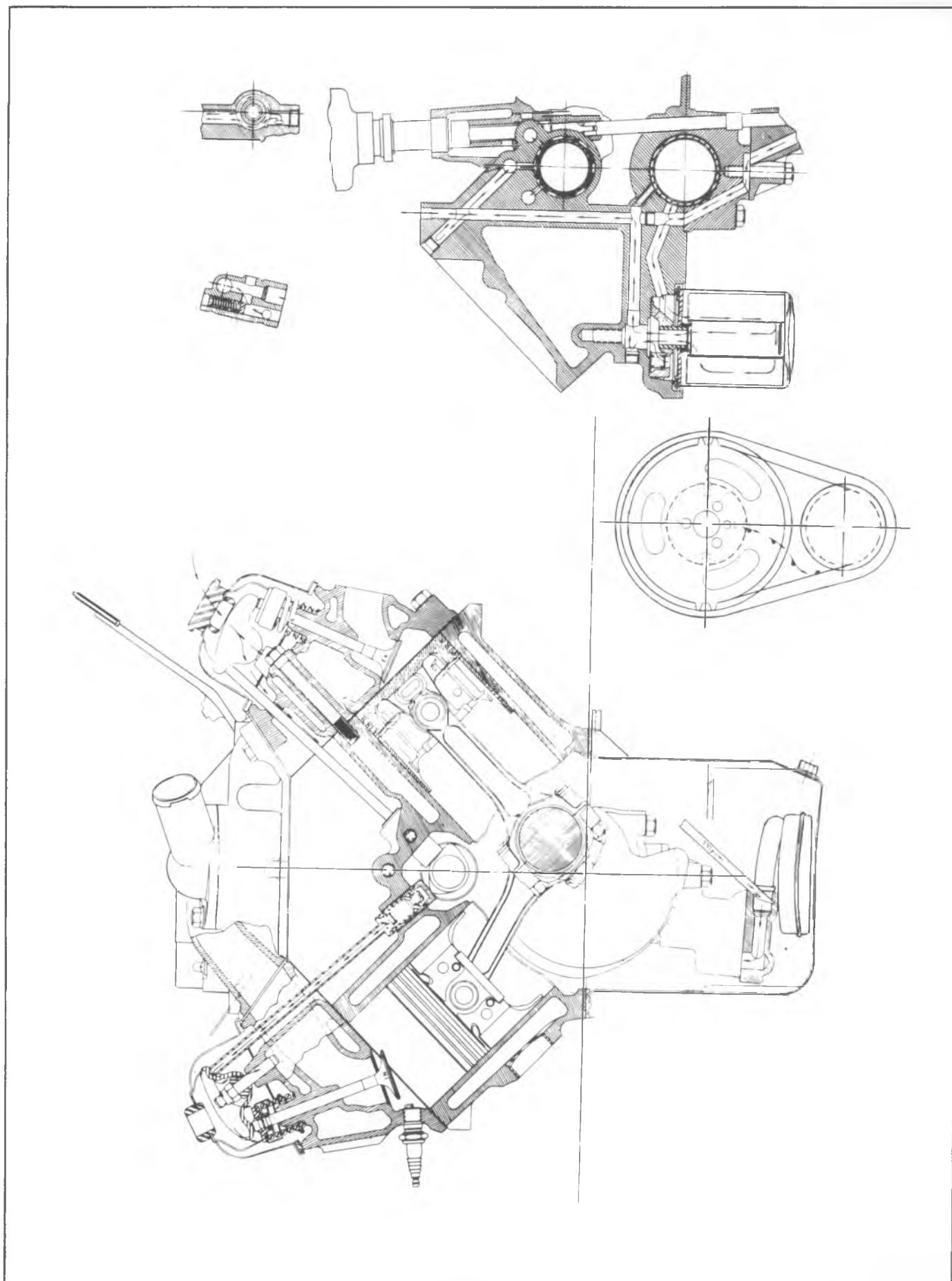

Fig. 1--Engine Lubrication



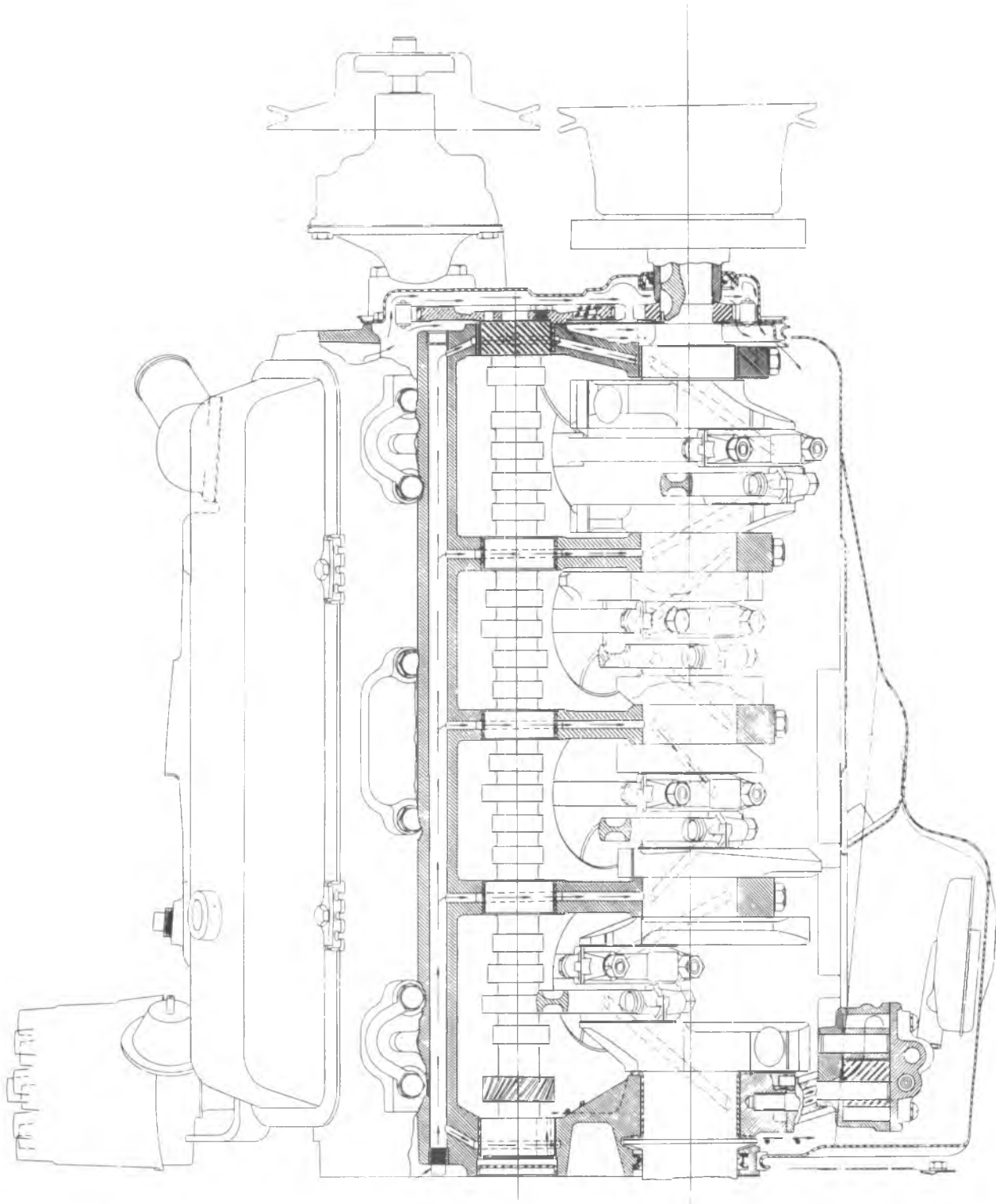

Fig. 2--Engine Lubrication

## ON VEHICLE SERVICE

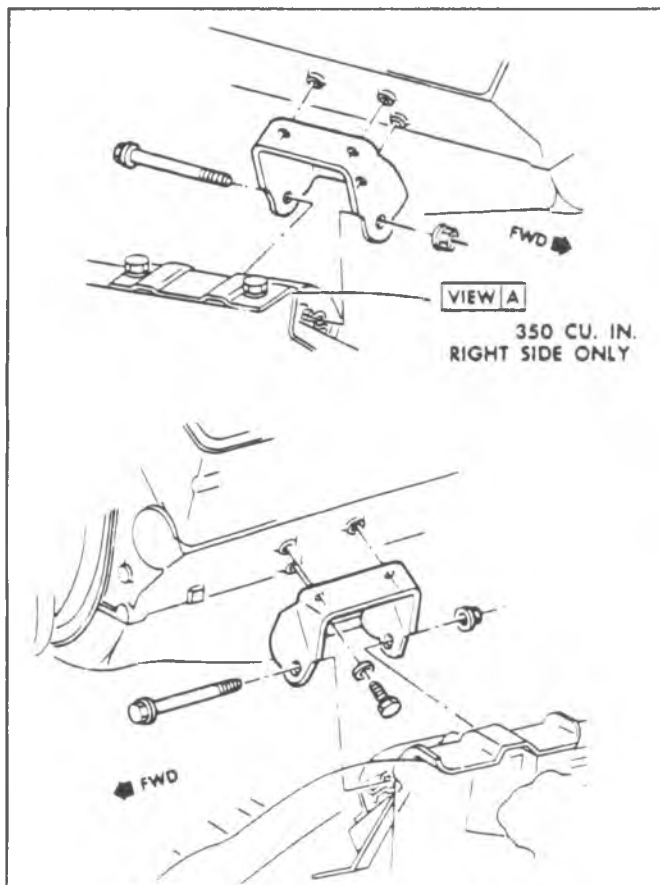

Fig. 3—"P" Series Engine Mount Bracket

### ENGINE MOUNTS

Engine mounts (figs. 3 - 8) are the non-adjustable type and seldom require service. Broken or deteriorated mounts should be replaced immediately, because of the added strain placed on other mounts and drive line components.

#### Checking Engine Mounts

##### Front Mount

Raise the engine to remove weight from the mounts and to place a slight tension in the rubber. Observe both mounts while raising engine. If an engine mount exhibits:

- a. Hard rubber surface covered with heat check cracks;
- b. Rubber separated from a metal plate of the mount;
- c. Rubber split through center

replace the mount. If there is relative movement between a metal plate of the mount and its attaching points, lower the engine on the mounts and tighten the screws or nuts attaching the mount to the engine, frame, or bracket.

##### Rear Mount

Raise the vehicle on a hoist. Push up and pull down on the transmission tailshaft while observing the transmission mount. If the rubber separates from the metal plate of the mount or if the tailshaft moves up but not down (mount bottomed out) replace the mount. If there is relative movement between a metal plate of the mount and its

attaching point, tighten the screws or nuts attaching the mount to the transmission or crossmember.

#### Front Mount Replacement

1. Remove mount retaining bolt from below frame mounting bracket.
2. Raise front of engine and remove mount-to-engine bolts and remove mount.

**NOTICE:** Raise engine only enough for sufficient clearance. Check for interference between rear of engine and cowl panel which could cause distributor damage.

3. Replace mount to engine and lower engine into place.
4. Install retaining bolt and torque all bolts to specifications.

#### Rear Mount Replacement

1. Support engine weight to relieve rear mounts.
2. Remove crossmember-to-mount bolts.
3. On "P" Series with manual transmission and propeller shaft parking brake, remove mount attaching bolts from frame outrigger and clutch housing and remove rear mounting cushions.
4. Remove mount-to-transmission bolts, then remove mount.
5. On "P" Series with manual transmission and propeller shaft parking brake, install new mounting cushions and bolts.
6. Install new mount on transmission.
7. While lowering transmission, align and start crossmember-to-mount bolts.
8. Torque bolts to specifications then bend lock tabs to bolt head as applicable.

### INTAKE MANIFOLD

#### Removal

1. Disconnect battery negative cable.
2. Remove air cleaner.
3. Drain cooling system.
4. On G-Van, remove engine cover.
5. Remove A.I.R. crossover hose.
6. Remove heater and radiator hoses.
7. Remove alternator upper bracket.
8. Disconnect necessary wires and hoses.
9. Disconnect fuel line at carburetor.
10. Disconnect carburetor linkage.
11. Remove spark plug wires (one side).
12. Remove distributor cap, mark position of rotor, then remove distributor.
13. Remove air conditioning compressor and bracket if equipped.
14. Remove brake vacuum pipe.
15. On vehicles equipped with 4 bbl carburetor, remove carburetor.
16. Remove manifold bolts.
17. Remove intake manifold.
  1. Clean gasket and seal surfaces on manifold, block,

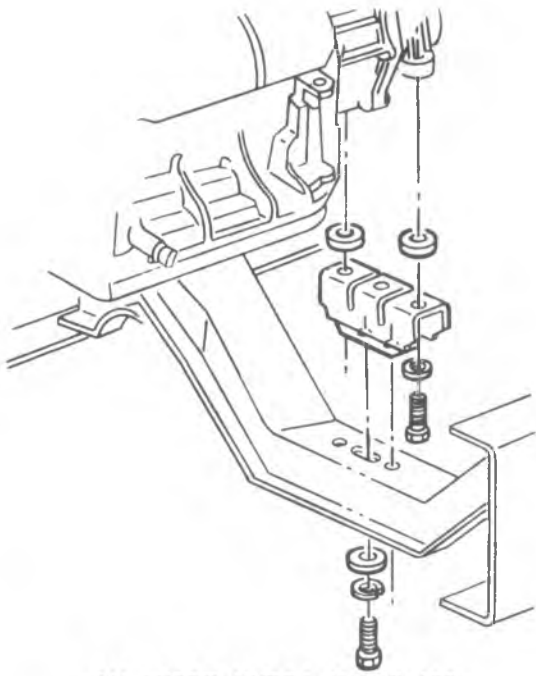

ALL TURBO HYDRA-MATIC 400  
(EXCEPT MOBILE HOME CHASSIS)

WITHOUT PROPELLER SHAFT PARKING BRAKE

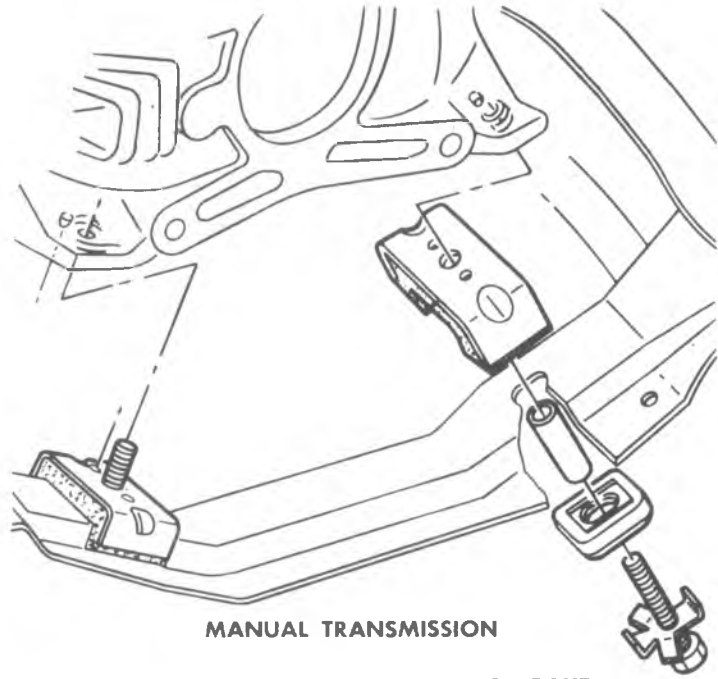

MANUAL TRANSMISSION

WITH PROPELLER SHAFT PARKING BRAKE

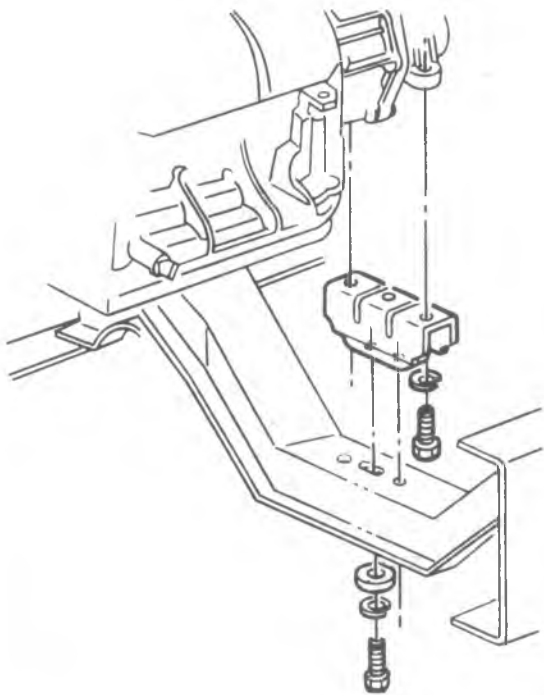

ALL MANUAL TRANSMISSION  
ALL TURBO HYDRA-MATIC 350  
ALL MOBILE HOME CHASSIS

WITHOUT PROPELLER SHAFT PARKING BRAKE

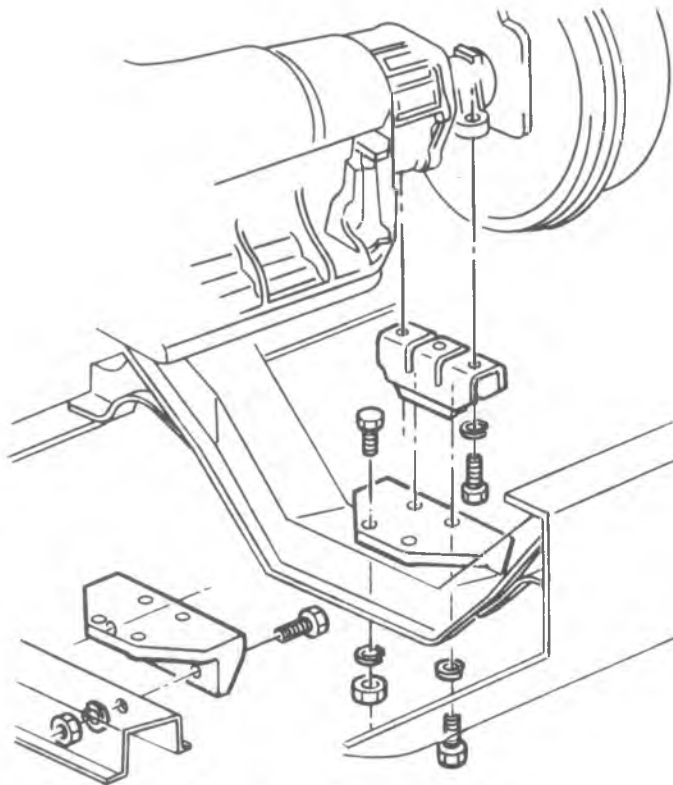

AUTOMATIC TRANSMISSION

WITH PROPELLER SHAFT PARKING BRAKE

Fig. 4--"P" Series Engine Rear Mount

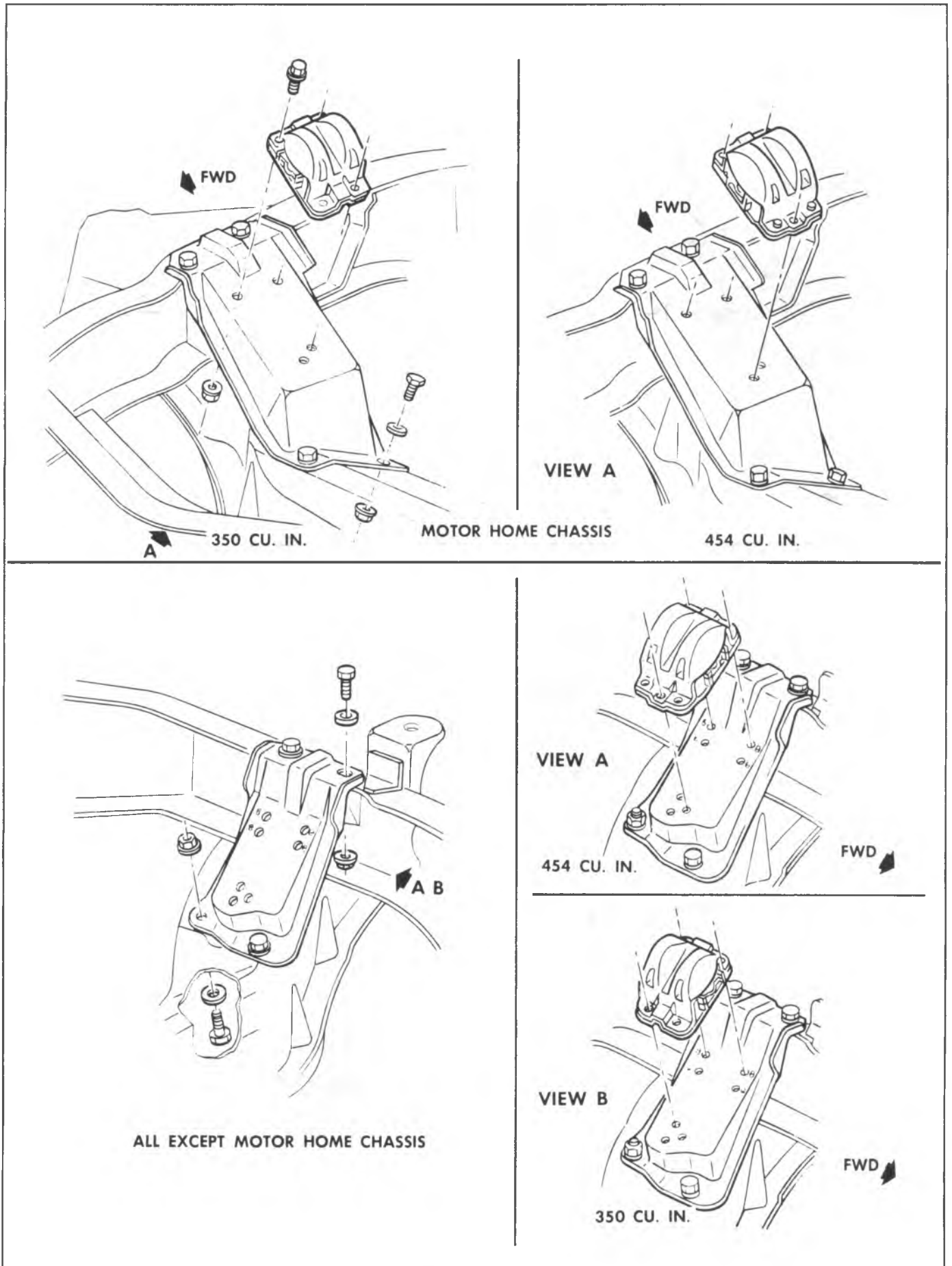

Fig. 5--"P" Series Engine Front Mount

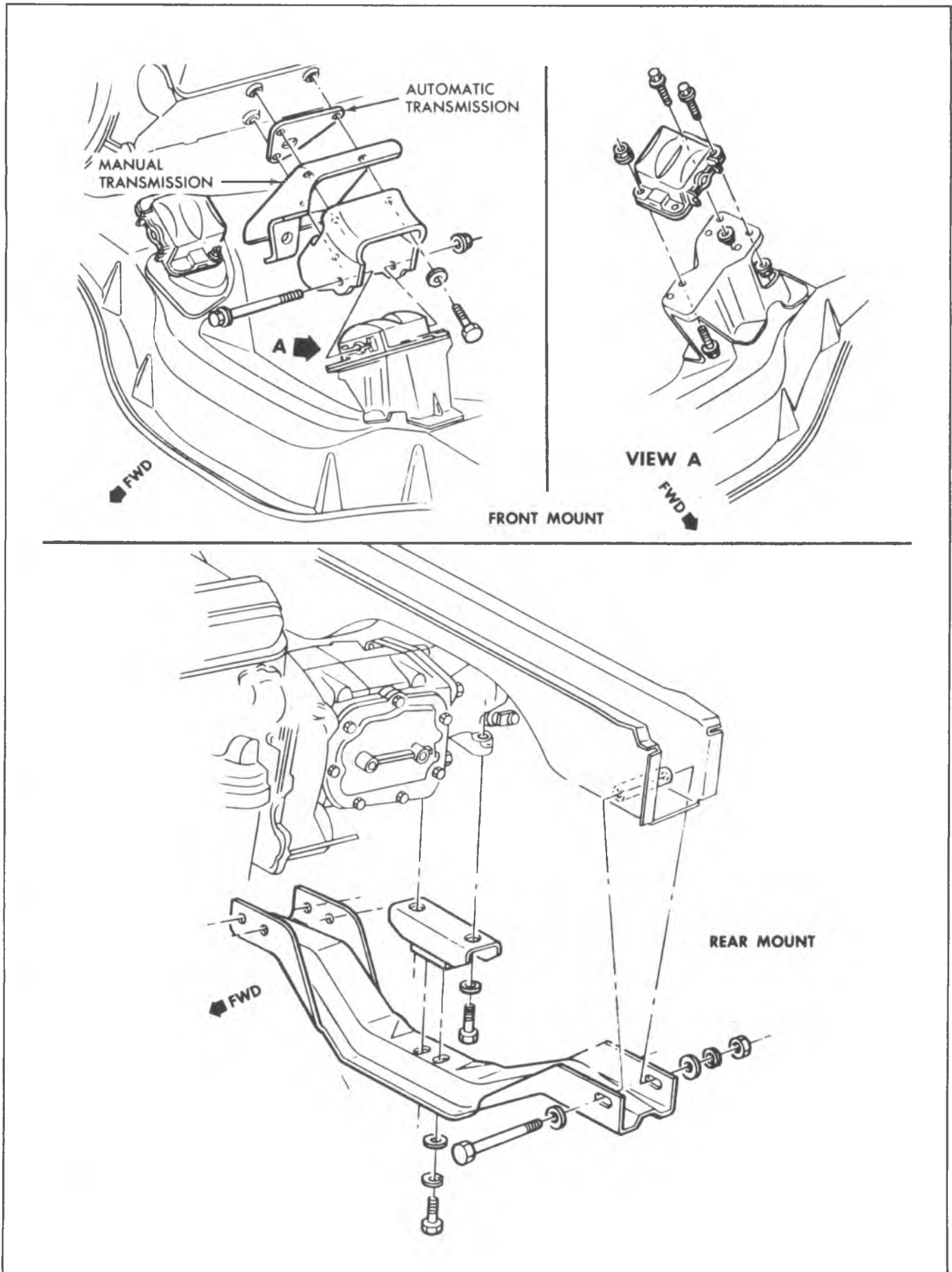

Fig. 6--"G" Series Engine Mounts

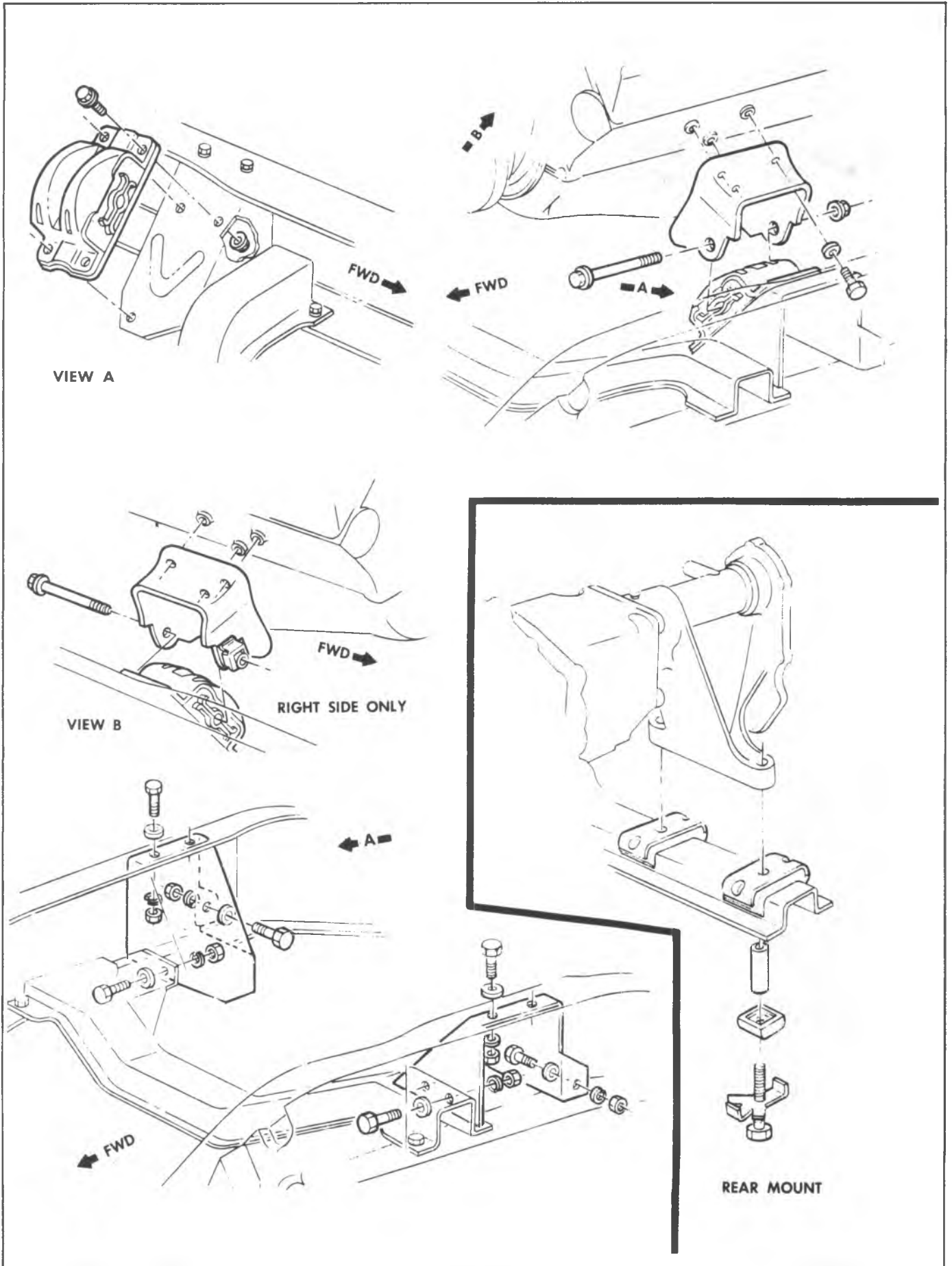

Fig. 7--"K" Series Engine Mounts

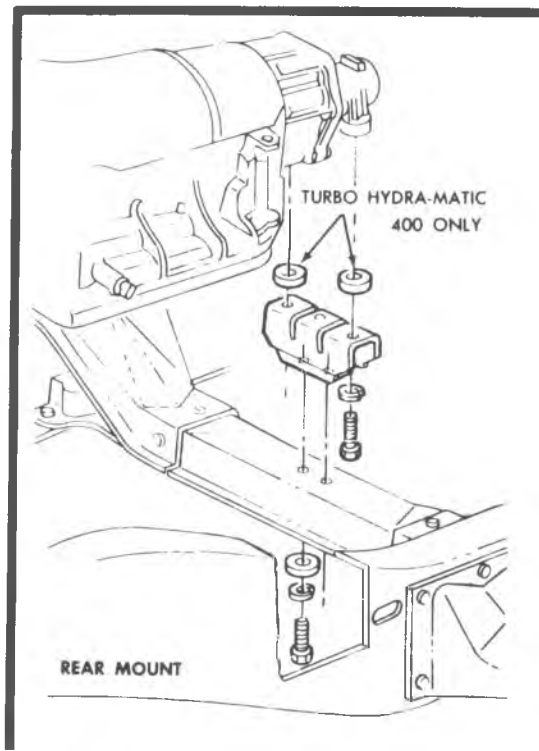
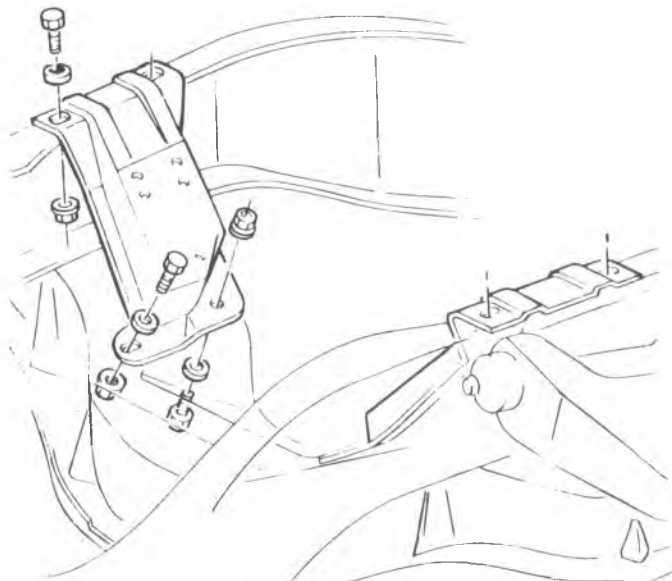
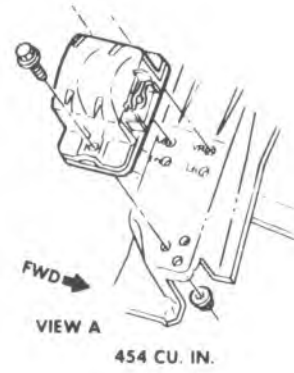
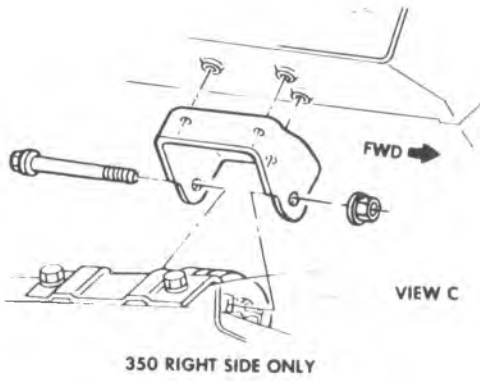
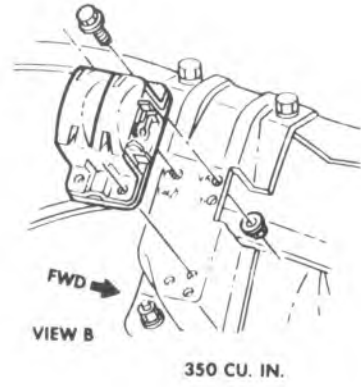
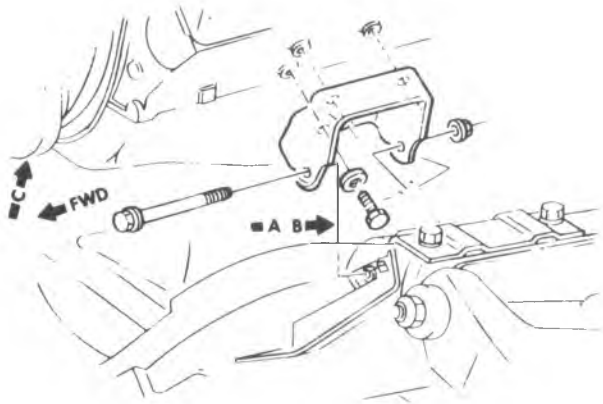

Fig. 8--"C" Series Engine Mounts



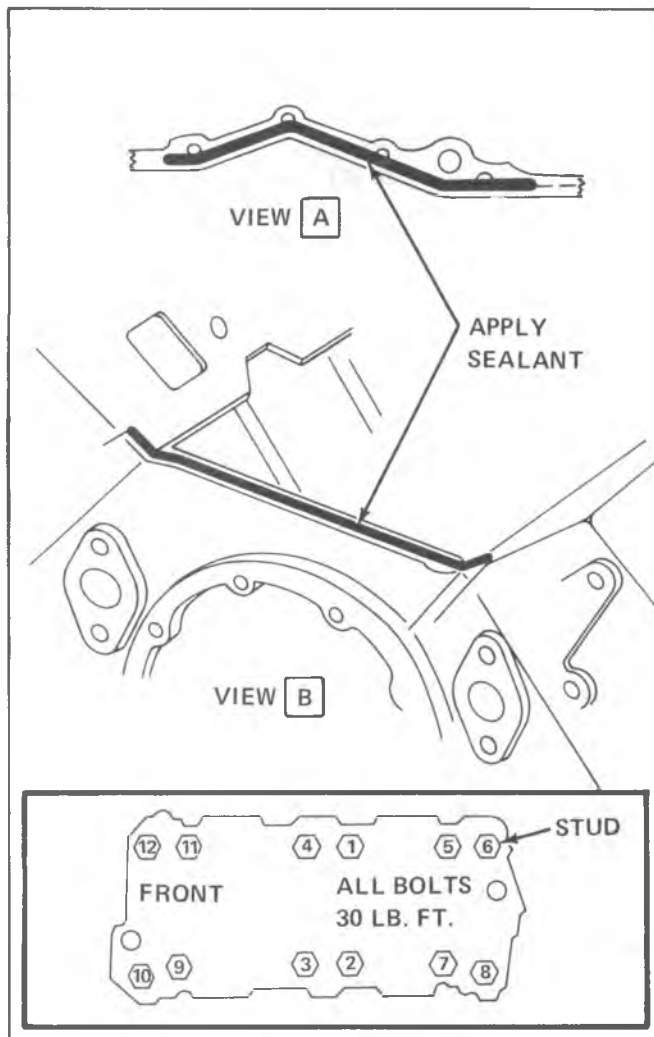

Fig. 9--Intake Manifold Torque Sequence

and cylinder heads with degreaser. Remove all RTV that is loose or will cause installation interference.

2. Install gaskets on cylinder heads and place a 3/16" (5mm) bead of RTV, #1052366 or equivalent, on the front and rear ridges of the cylinder case. Extend the bead 1/2" (13mm) up each cylinder head to seal and retain the manifold side gaskets. Use sealer at water passages.
3. Install manifold and torque bolts to specifications in the sequence outlined in Figure 9.
4. Install carburetor.
5. Install A/C, compressor and bracket if equipped.
6. Install brake vacuum pipe.
7. Install distributor align rotor with mark and install distributor cap.
8. Install spark plug wires.
9. Install carburetor linkage.
10. Connect fuel line at carburetor.
11. Connect necessary wires and hoses.
12. Install alternator upper bracket.
13. Install heater and radiator hoses.
15. Install A.I.R. crossover hose.
15. On G-Van, install engine cover.
16. Fill cooling system. Follow Owner's Manual for proper procedures and capacities.
17. Install air cleaner.
18. Start engine, adjust timing and carburetor idle speeds (if necessary) and check for leaks.

## EXHAUST MANIFOLD

### Removal

1. Remove carburetor heat stove pipe.
2. Remove the spark plug wiring heatshields.
3. Disconnect exhaust pipe from manifold and hang exhaust pipe from frame with wire.
4. Remove end bolts then remove center bolts and

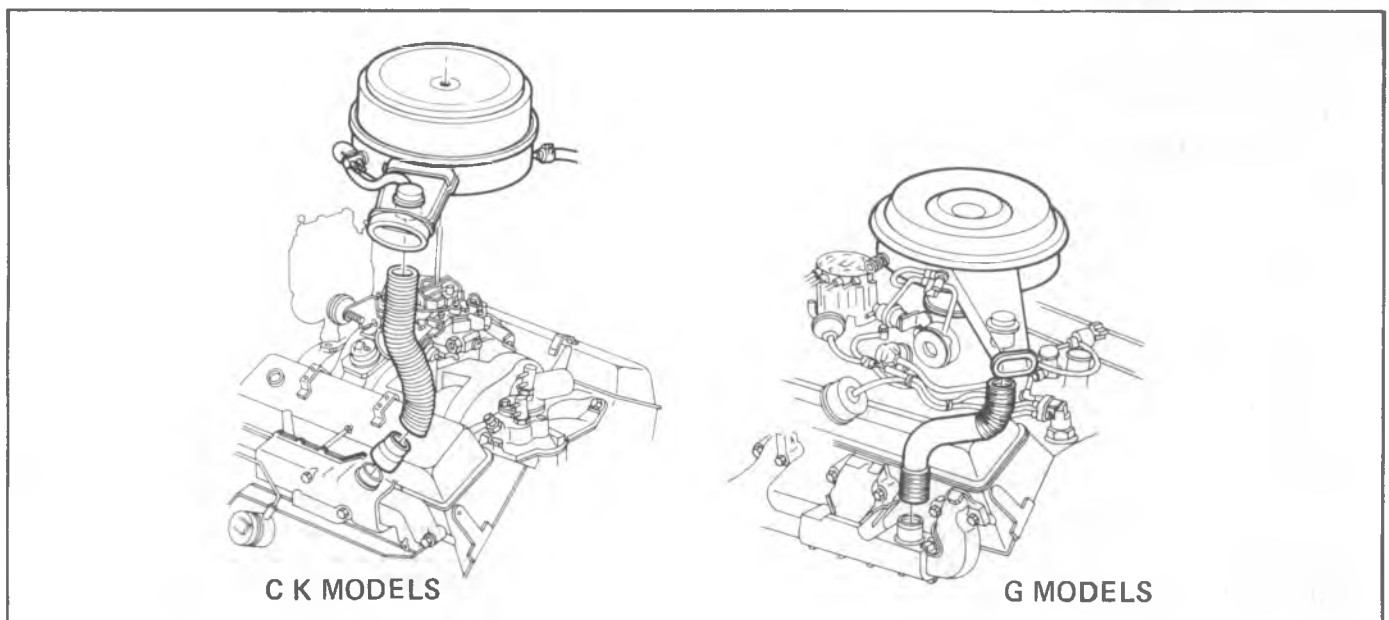

Fig. 10--Carburetor Heat Stove Assembly



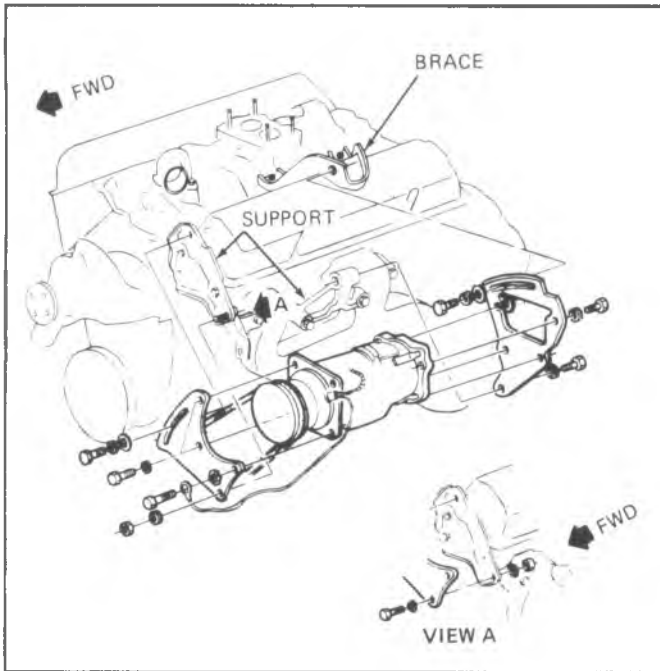

Fig. 11--A/C Compressor Mounting

remove manifold.

#### Installation

- If installing a new right side manifold, the carburetor heat stove must be transferred from the old unit (fig. 10).
1. Clean mating surfaces on manifold and head, then install manifold in position and install bolts (fingertight).
  2. Torque manifold bolts to specifications.
  3. Connect exhaust pipe to manifold.
  4. Install carburetor heat stove pipe.
  5. Install spark plug wiring heatshields.
  6. Start engine and check for leaks.

#### ROCKER ARM COVER (Fig. 12)

##### Removal

1. Disconnect battery negative cable.
2. Remove air cleaner.
3. Disconnect crankcase ventilation hoses at rocker arm covers.
4. Disconnect electrical wiring harness from rocker arm clips.
5. Remove carburetor heat stove pipe from right exhaust manifold.
6. If the vehicle is equipped with air conditioning, remove the A/C compressor rear brace (fig. 11).
7. Remove rocker arm cover to head attaching bolts and remove rocker arm cover.

**NOTICE:** If cover adheres to cylinder head, shear off by bumping end of rocker arm cover with a block of wood and a rubber mallet. If cover still will not come loose, **CAREFULLY** pry until loose. **DO NOT DISTORT SEALING FLANGE.**

#### Installation

1. Clean sealing surface on cylinder head and rocker arm cover with degreaser. Using a 3/16" (5mm) bead of RTV, #1052366 or equivalent, place rocker arm cover on the head, install retaining bolts and torque to 40 lb. in. (4.6 N·m). Loose RTV sealant, or pieces causing installation interference, must be removed from both cylinder head and cover seal surfaces prior to applying new sealant.
  - When going around the attaching bolt holes, always flow the RTV on the inboard side of the holes. Install cover and torque bolts while RTV is still wet (within 10 minutes).
2. On A/C equipped vehicles, install the A/C compressor upper brace. Adjust pulley belt to specification.
3. Install carburetor heat stove pipe.
4. Connect electrical wiring harness at clips on rocker arm cover.
5. Connect crankcase ventilation hoses.
6. Install air cleaner. Connect battery negative cable, start engine and check for leaks.

#### VALVE MECHANISM

##### Removal

1. Remove rocker arm covers as previously outlined.
2. Remove rocker arm nuts, rocker arm balls, rocker arms and push rods. Place rocker arms, rocker arm balls and push rods in a rack so they may be reinstalled in the same locations.

##### Installation and Adjustment

- Whenever new rocker arms and/or rocker arm balls are being installed, coat bearing surfaces of rocker arms and rocker arm balls with "Molykote" or its equivalent.
1. Install push rods. Be sure push rods seat in lifter socket.
  2. Install rocker arms, rocker arm balls and rocker arm nuts. Tighten rocker arm nuts until all lash is eliminated.

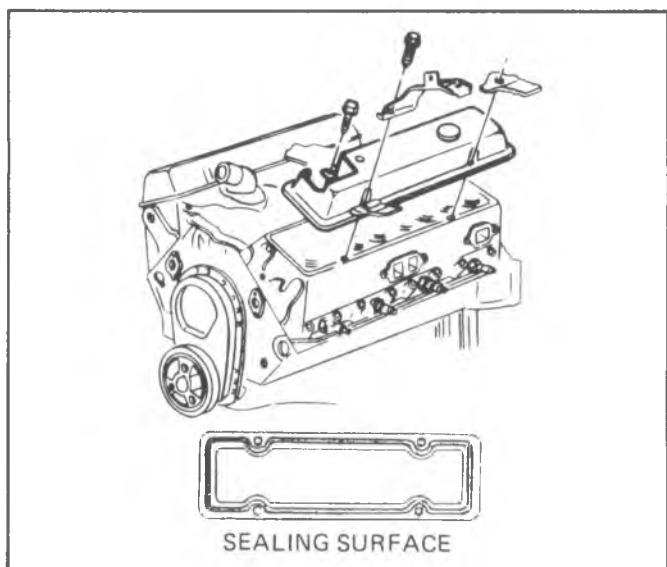

Fig. 12--Rocker Arm Cover Installation

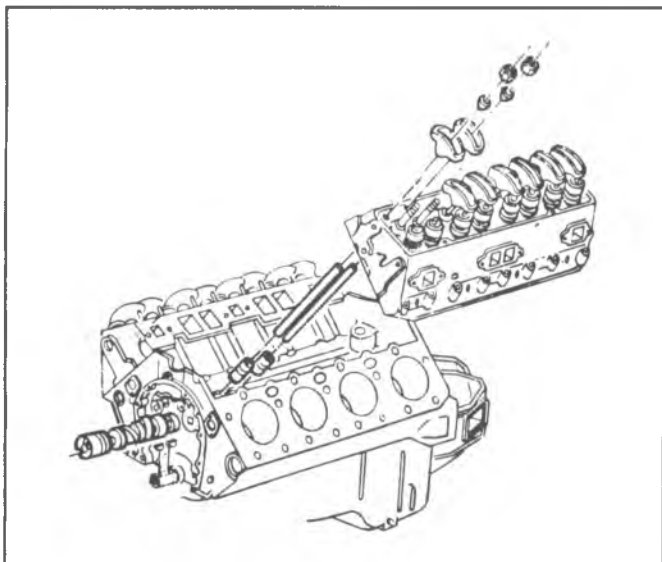

Fig. 13 -- Rocker Arms and Pushrods

3. Adjust valves when lifter is on base circle of camshaft lobe as follows:

a. Crank engine until mark on torsional damper lines up with center or "O" mark, on the timing tab, fastened to the crankcase front cover, and the engine is in the #1 firing position. This may be determined by placing fingers on the #1 valve as the mark on the damper comes near the "O" mark on the crankcase front cover. If the valves are not moving, the engine is in the #1 firing position. If the valves move as the mark comes up to the timing tab, the engine is in #6 firing position and should be rotated one more time to reach the #1 position.

b. With the engine in the #1 firing position as just determined, the following valves may be adjusted:

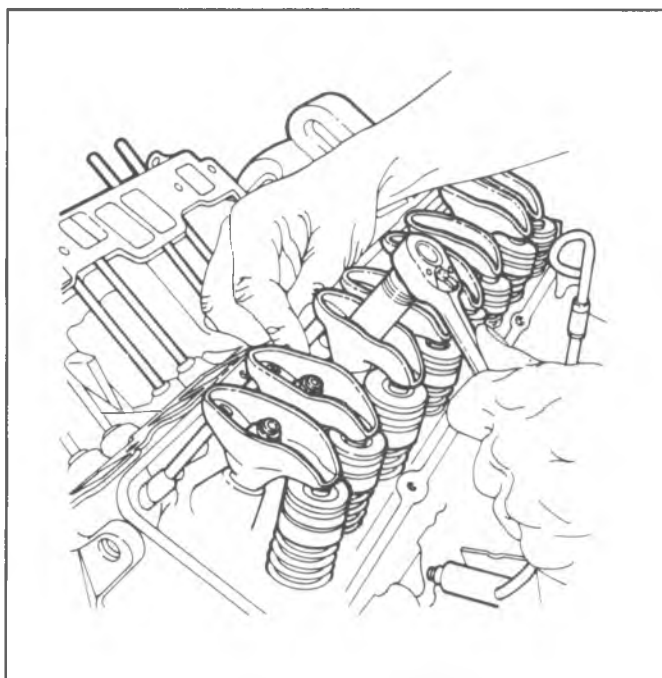

Fig. 14--Valve Adjustment

- Exhaust--1, 3, 4, 8
  - Intake--1, 2, 5, 7
- c. Back out adjusting nut until lash is felt at the push rod then turn in adjusting nut until all lash is removed. This can be determined by rotating push rod while turning adjusting nut (fig. 14). When play has been removed, turn adjusting nut in one full additional turn (to center lifter plunger).
- d. Rotate the engine one revolution until the pointer "O" mark and torsional damper mark are again in alignment. This is the #6 firing position. With the engine in this position the following valves may be adjusted.
- Exhaust--2, 5, 6, 7
  - Intake--3, 4, 6, 8
4. Install rocker arm covers as previously outlined.
5. Start engine and adjust carburetor idle speed, if needed.

### VALVE STEM OIL SEAL and/or VALVE SPRING (Fig. 15)

#### Removal

1. Remove rocker arm cover as previously outlined.
2. Remove spark plug, rocker arm and push rod on the cylinder(s) to be serviced.
3. Install air line adapter Tool J-23590 to spark plug port and apply compressed air to hold the valves in place.
4. Using Tool J-5892 to compress the valve spring, remove the valve locks, valve cap, oil shedder and valve spring and damper (fig. 16).
5. Remove the valve stem oil or head oil seal.

#### Installation

1. Install valve stem seal over valve stem and seat against head.
2. Set the valve spring and damper, oil shedder and valve cap in place. Compress the spring with Tool J-5892 and sure the seal is flat and not twisted. A light coat of oil on the seal will help prevent twisting.

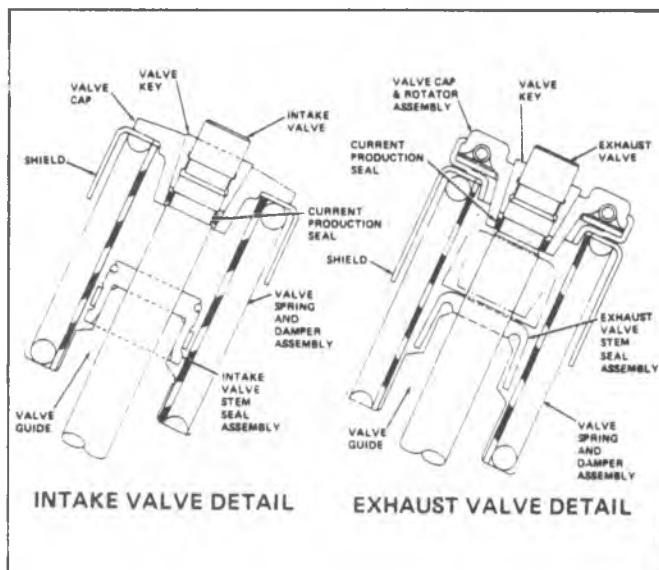

Fig. 15--Valve Seals

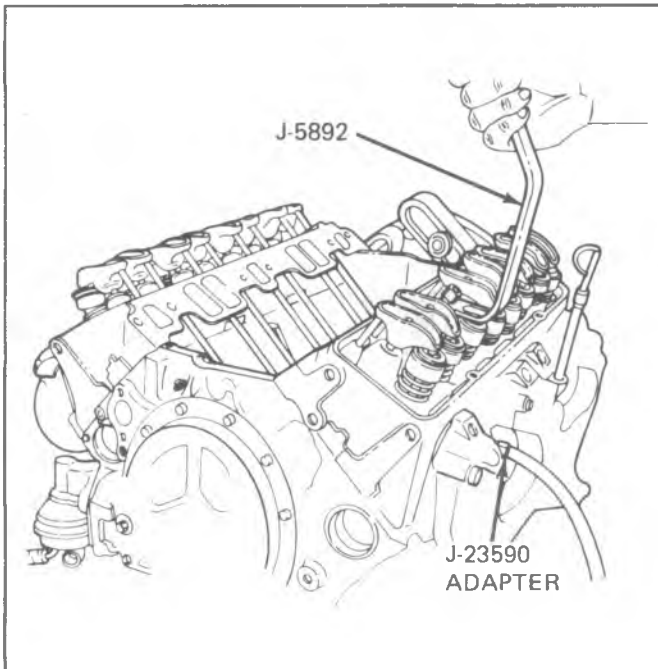

Fig. 16--Compressing Valve Spring

3. Install the valve locks and release the compressor tool making sure the locks seat properly in the upper groove of the valve stem. Grease may be used to hold the locks in place while releasing the compressor tool.
4. Using tool J-23994, apply vacuum to the valve cap to make sure no air leaks past the seal.
5. Install spark plug, and torque to 22 lb. ft. (30 N·m).
6. Install and adjust valve mechanism as previously outlined.

## VALVE LIFTERS

Hydraulic valve lifters very seldom require attention. The lifters are extremely simple in design, readjustments

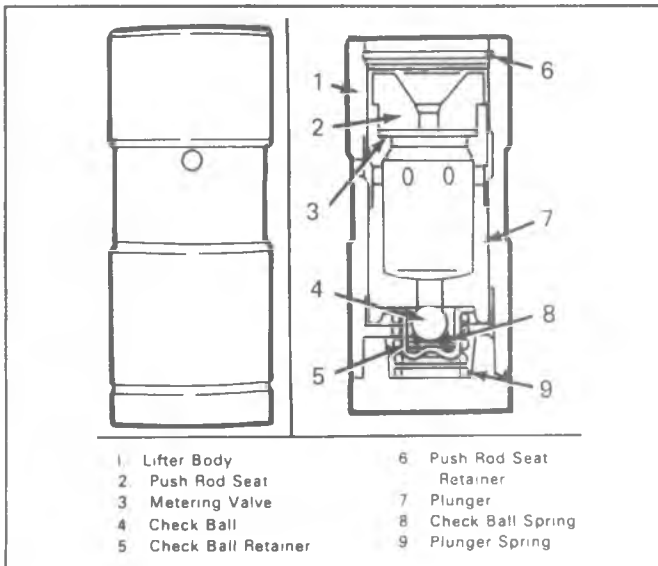

Fig. 17--Hydraulic Valve Lifter

are not necessary, and servicing of the lifters requires only that care and cleanliness be exercised in the handling of parts.

## Removal

1. Remove intake manifold as previously outlined.
2. Remove valve mechanism as previously outlined.
3. Remove valve lifters. Place valve lifters in a rack so that they may be reinstalled in the same location.

## Installation

1. Coat foot of valve lifters with "Molykote" or its equivalent and install valve lifters. Make sure lifter foot is convex.
2. Install intake manifold as previously outlined.
3. Install and adjust valve mechanism as outlined.

## Disassembly

1. Hold the plunger down with a push rod, and using the blade of a small screw driver, remove the push rod seat retainer.
2. Remove the push rod seat and metering valve (fig. 17).
3. Remove the plunger, ball check valve assembly and the plunger spring.
4. Remove the ball check valve and spring by prying the ball retainer loose from the plunger with the blade of a small screw driver (fig. 18).

## Cleaning and Inspection

Thoroughly clean all parts in cleaning solvent, and inspect them carefully. If any parts are damaged or worn, the entire lifter assembly should be replaced. If the lifter body wall is scuffed or worn, inspect the cylinder block lifter bore. If the bottom of the lifter is scuffed or worn, inspect the camshaft lobe. If the push rod seat is scuffed or worn, inspect the push rod. An additive containing EP lube, such as EOS, should always be added to crankcase oil for run-in when any new camshaft or lifters are installed.



Fig. 18--Removing Ball Check Valve

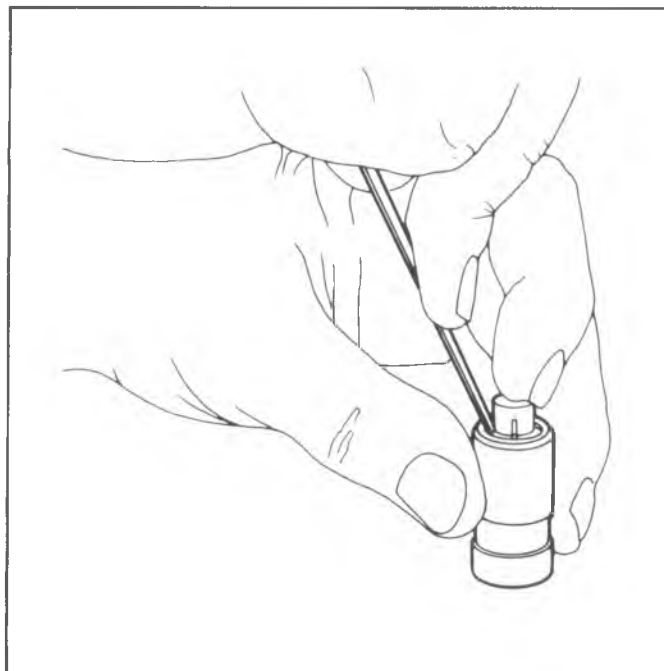

Fig. 19--Installing Ball Check Valve

All damaged or worn lifters should be replaced.

Whenever a new camshaft is installed, replace oil, oil filter and all valve lifters. Install GM E.O.S. or equivalent over the cam and lifter feet after the parts are installed.

- For proper lifter rotation during engine operation, lifter foot must be convex.

#### Assembly

1. Place the check ball on small hole in bottom of the plunger.
2. Insert check ball spring on seat in ball retainer and place retainer over ball so that spring rests on the ball. Carefully press the retainer into position in plunger with the blade of a small screw driver (fig. 19).
3. Place the plunger spring over the ball retainer and slide the lifter body over the spring and plunger, being careful to line up the oil feed holes in the lifter body and plunger.
4. Fill the assembly with SAE 10 oil, then insert the end of a 1/8" drift pin into the plunger and press down solid. Do not attempt to force or pump the plunger. At this point, oil holes in the lifter body and plunger assembly will be aligned (fig. 20).
5. Insert a 1/16" drift pin through both oil holes to hold the plunger down against the lifter spring tension (fig. 20).
6. Remove the 1/8" drift pin, refill assembly with SAE 10 oil.
7. Install the metering valve and push rod seat (fig. 17).
8. Install the push rod seat retainer, press down on the push rod seat and remove the 1/16" drift pin from the oil holes. The lifter is now completely assembled, filled with oil and ready for installation. Before installing lifters, coat the bottom of the lifter with "Molykote" or its equivalent.

## CYLINDER HEAD ASSEMBLY

### Removal

1. Remove intake manifold as previously outlined.
2. Remove generator lower mounting bolt and lay unit aside.
3. Remove exhaust manifolds as previously outlined.
4. Drain cylinder block of coolant.
5. If vehicle is equipped with A/C, remove A/C compressor and forward mounting bracket. Lay unit aside.
6. Remove valve push rods as previously outlined.
7. Remove cylinder head bolts, cylinder head and gasket. Place cylinder head on two blocks of wood to prevent damage.

### Disassembly

1. With cylinder head removed, remove valve rocker arm nuts, balls and rocker arms (if not previously done).
2. Using Tool J-8062, compress the valve springs (fig. 21) and remove valve keys. Release the compressor tool and remove rotators or spring caps, oil shedders, springs and spring damper, then remove oil seals and valve spring shims.
3. Remove valves from cylinder head and place them in a rack in their proper sequence so that they can be assembled in their original positions.

### Cleaning

1. Clean all carbon from combustion chambers and valve ports using Tool J-8089 (fig. 22).
2. Thoroughly clean the valve guides using Tool J-8101.
3. Clean all carbon and sludge from push rods, rocker arms and push rod guides.
4. Clean valve stems and heads on a buffing wheel.

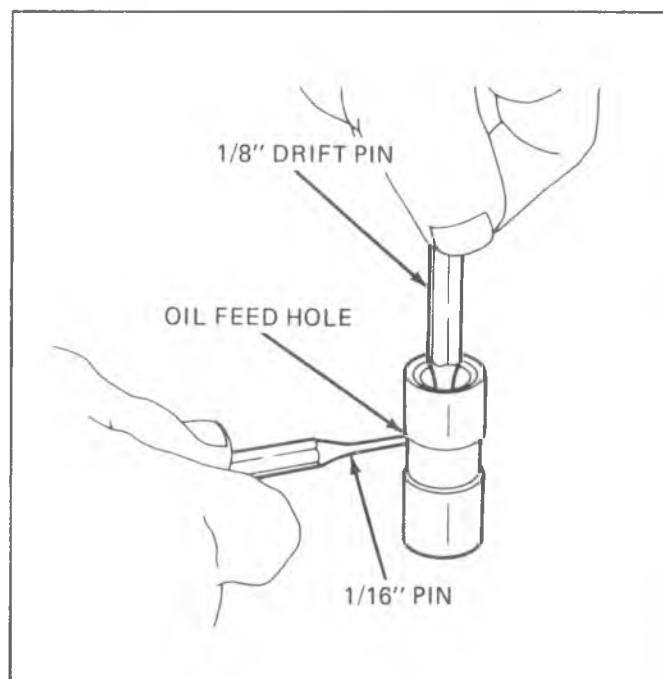

Fig. 20--Assembling Hydraulic Lifter

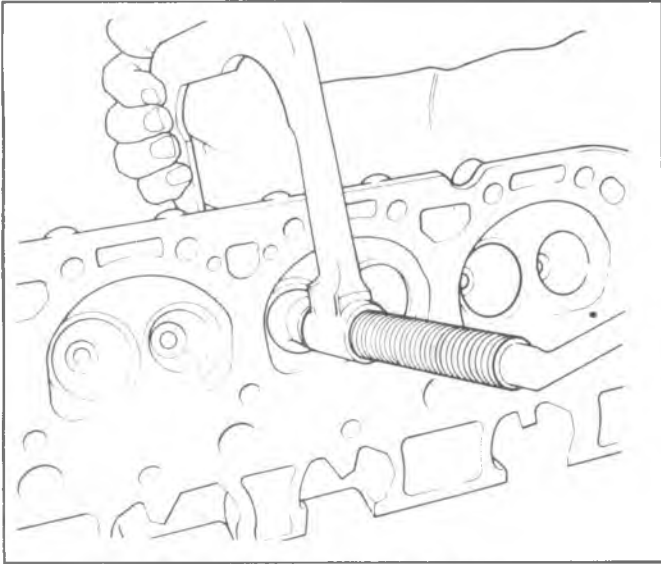

Fig. 21--Compressing Valve Spring

5. Clean carbon deposits from head gasket mating surface.

#### Inspection

1. Inspect the cylinder head for cracks in the exhaust ports, combustion chambers, or external cracks to the coolant chamber.
2. Inspect the valves for burned heads, cracked faces or damaged stems.

**NOTICE:** Excessive valve stem to bore clearance will cause excessive oil consumption and may cause valve breakage. Insufficient clearance will result in noisy and sticky functioning of the valve and disturb engine smoothness.

3. Measure valve stem clearance (fig. 23) as follows:
  - a. Clamp a dial indicator on one side of the cylinder head rocker arm cover gasket rail.
  - b. Locate the indicator so that movement of the valve stem from side to side (crosswise to the head) will cause a direct movement of the indicator

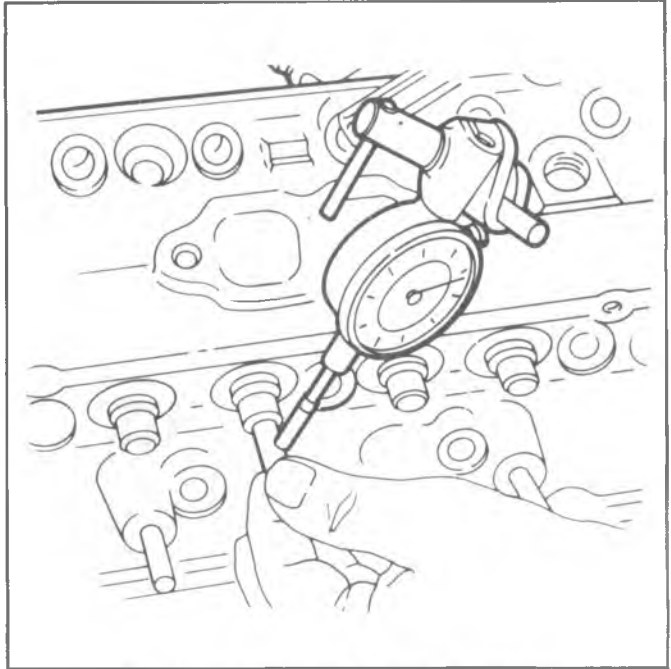

Fig. 23--Measuring Valve Stem Clearances

stem. The indicator stem must contact the side of the valve stem just above the valve guide.

- c. Drop the valve head about 1/16" (1.6mm) off the valve seat.
- d. Move the stem of the valve from side to side using light pressure to obtain a clearance reading. If clearance exceeds specifications, it will be necessary to ream valve guides for oversize valves as outlined.
4. Check valve spring tension with Tool J-8056 spring tester (fig. 24). Springs should be compressed to the specified height and checked against the specifications chart. Springs should be replaced if not within 10 lbs. (44 N) of the specified load (without dampers).

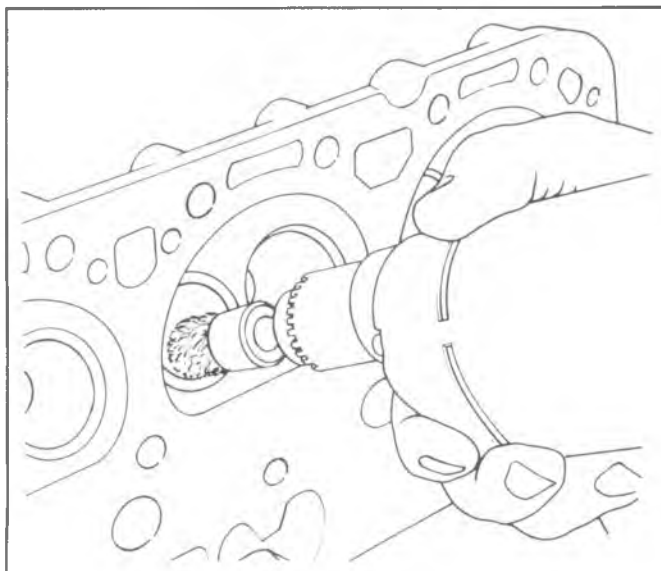

Fig. 22--Cleaning Combustion Chambers

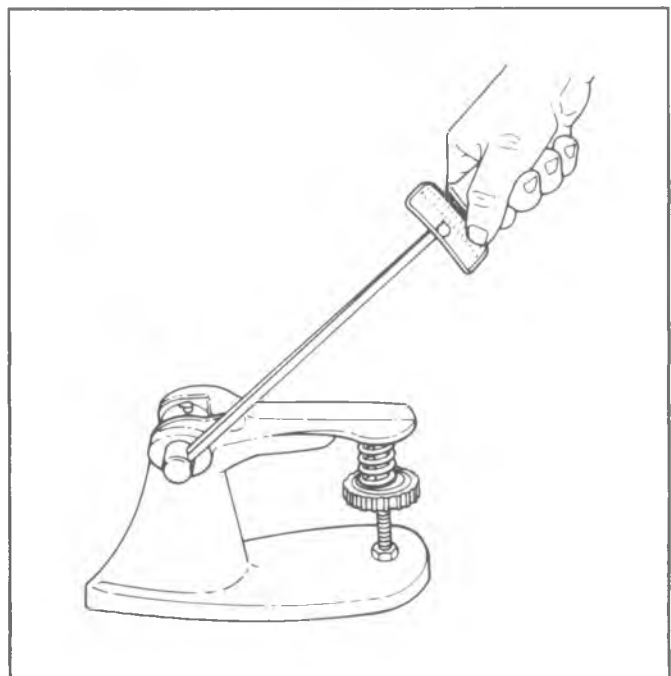

Fig. 24--Checking Valve Spring Tension

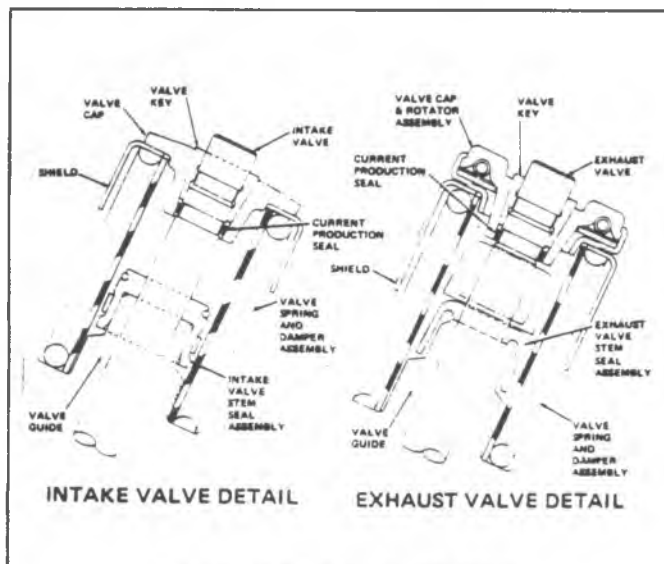

Fig. 25--Valve Spring Installation

5. Inspect rocker arm studs for wear or damage.

**Assembly**

1. Insert a valve in the proper port.
2. Assemble the valve spring and related parts as follows:
  - a. Set the valve spring shim, valve spring, oil shedder and valve cap or rotator in place (fig. 25).
  - b. Compress the spring with Tool J-8062.
  - c. Install oil seal in the lower groove of the stem, making sure that the seal is flat and not twisted.
  - d. Install the valve locks and release the compressor tool, making sure that the locks seat properly in the upper groove of the valve stem. Grease may be used to hold the locks in place while releasing the compressor tool.
3. Install the remaining valves.
4. Check each valve stem oil seal by placing Valve Seal Leak Detector (Tool J-23994) over the end of the

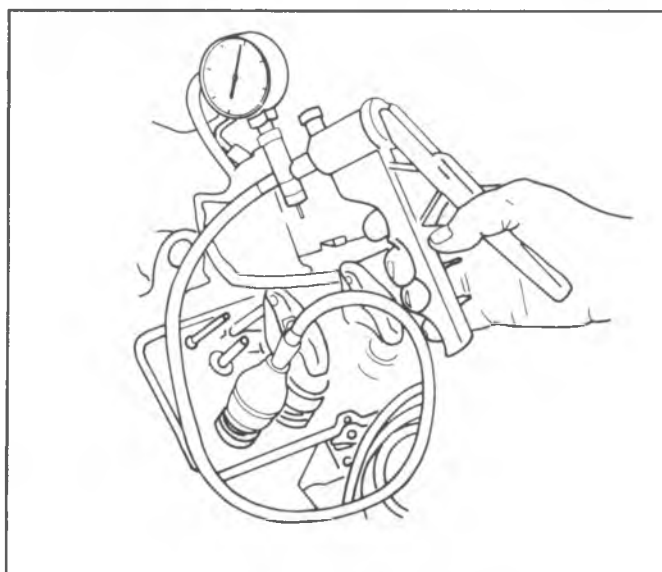

Fig. 26--Checking Valve Stem Oil Seals

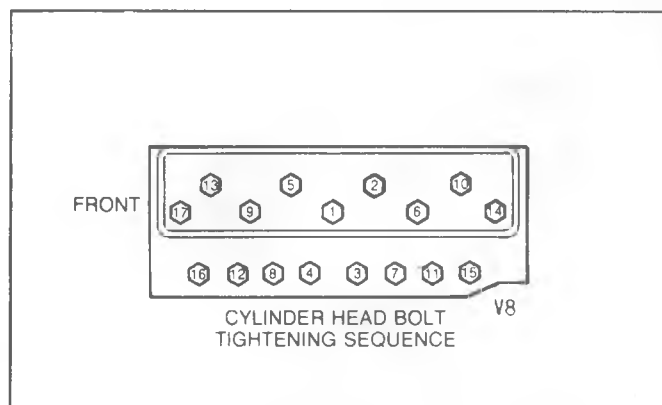

Fig. 27--Cylinder Head Torque Sequence

valve stem and against the cap. Operate the vacuum pump and make sure no air leaks past the seal (fig. 26).

5. Check the installed height of the valve springs, using a narrow thin scale. A cutaway scale will help (fig. 27). Measure from the top of the shim or the spring seat to the top of the oil shedder (fig. 28). If this is found to exceed the specified height, install a valve spring seat shim approximately 1/16" (1.6mm) thick. At no time should the spring be shimmed to give an installed height under the minimum specified.

**Installation**

- The gasket surfaces on both the head and the block must be clean of any foreign matter and free of nicks or heavy scratches. Cylinder bolt threads in the block and threads on the cylinder head bolts must be clean as dirt will affect bolt torque.
1. If using a STEEL gasket, coat both sides of a new gasket with a good sealer. Spread the sealer thin and even. One method of applying the sealer that will assure the proper coat is with the use of a paint roller. Too much sealer may hold the gasket away from the head or block.
    - Use no sealer if using a composition STEEL ASBESTOS gasket.

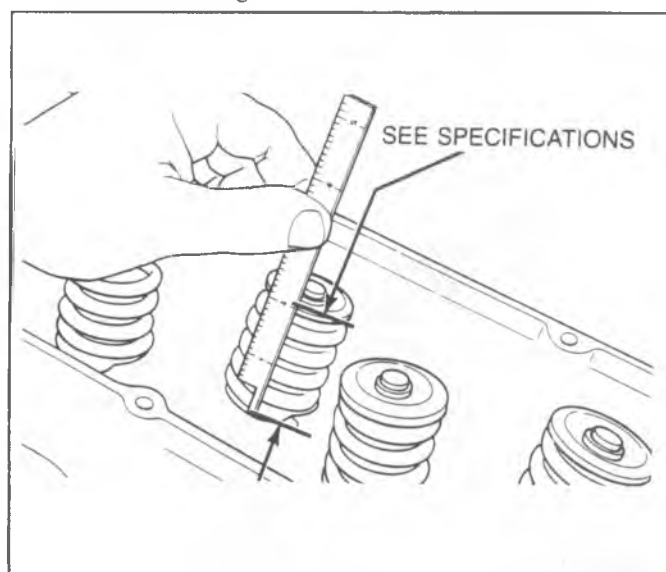

Fig. 28--Measuring Valve Spring Installed Height

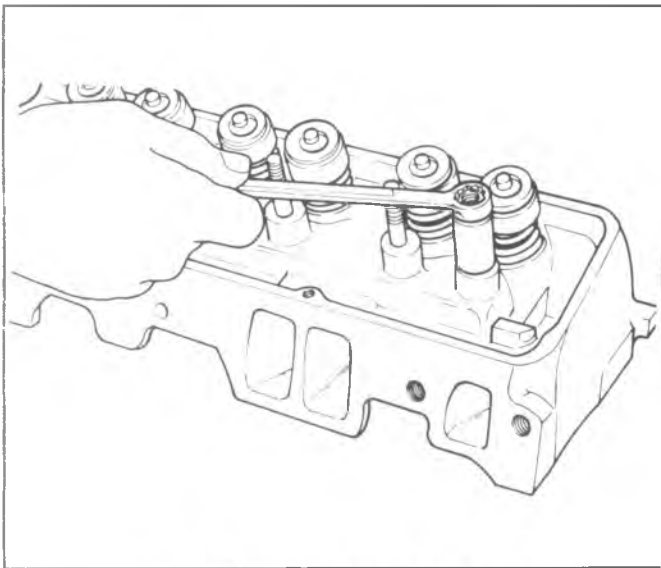

Fig. 29--Removing Rocker Arm Stud

2. Place the gasket in position over the dowel pins with the bead up.
3. Carefully guide the cylinder head into place over the dowel pins and gasket.
4. Coat threads of cylinder head bolts with sealing compound, #1052080 or equivalent, and install bolts finger tight.
5. Tighten each cylinder head bolt a little at a time in the sequence shown in the torque sequence chart until the specified torque is reached.
6. Install exhaust manifolds as previously outlined.
7. Install intake manifold as previously outlined.
8. Install and adjust valve mechanism as previously outlined.

## ROCKER ARM STUDS

### Replacement

Rocker arm studs that have damaged threads or are loose in cylinder heads should be replaced with new studs

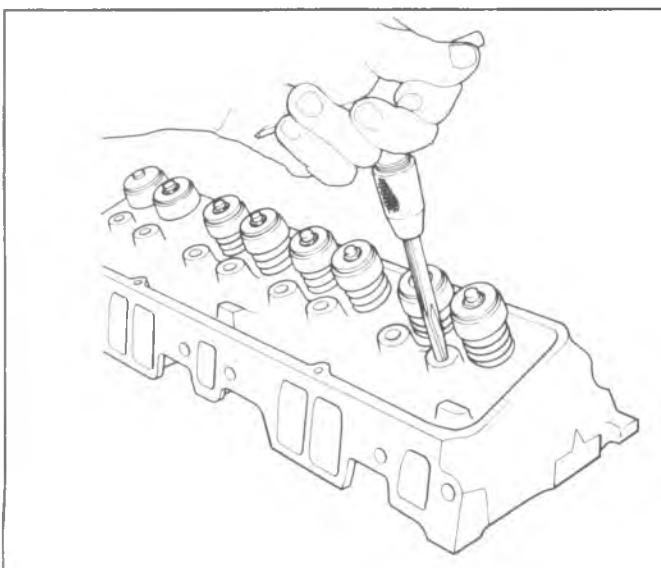

Fig. 30--Reaming Rocker Arm Stud Bore

available in .003" and .013" oversize. Studs may be installed after reaming the holes as follows:

1. Remove old stud by placing Tool J-5802-1 over the stud, installing nut and flat washer and removing stud by turning nut (fig. 29).
2. Ream hole for oversize stud using Tool J-5715 for .003" oversize or Tool J-6036 for .013" oversize (fig. 30).

**NOTICE:** Do not attempt to install an oversize stud without reaming stud hole as this could damage the head casting.

3. Coat press-fit area of stud with hypoid axle lubricant. Install new stud, using Tool J-6880 as a guide. Gage should bottom on head (fig. 31).

## VALVE GUIDE BORES

Valves with oversize stems are available (see specifications). To ream the valve guide bores for oversize valves use Tool Set J-5830.

## VALVE SEATS

Reconditioning the valve seats is very important, because the seating of the valves must be perfect for the engine to deliver the power and performance built into it.

Another important factor is the cooling of the valve heads. Good contact between each valve and its seat in the head is imperative to insure that the heat in the valve head will be properly carried away.

Several different types of equipment are available for reseating valves seats. The recommendations of the manufacturer of the equipment being used should be carefully followed to attain proper results.

Regardless of what type of equipment is used, however, it is essential that valve guide bores be free from carbon or dirt to ensure proper centering of pilot in the guide.

## VALVES

Valves that are pitted can be refaced to the proper angle, insuring correct relation between the head and stem on a valve refacing mechanism. Valve stems which show excessive wear, or valves that are warped excessively should be replaced. When a valve head which is warped excessively

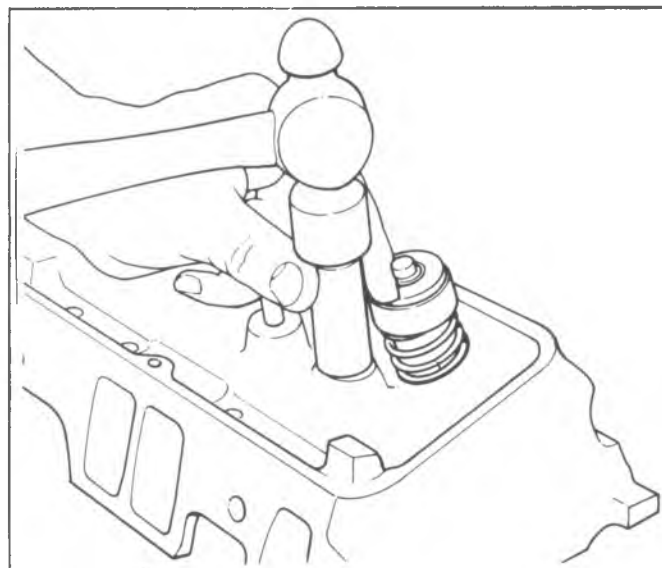

Fig. 31--Installing Rocker Arm Stud



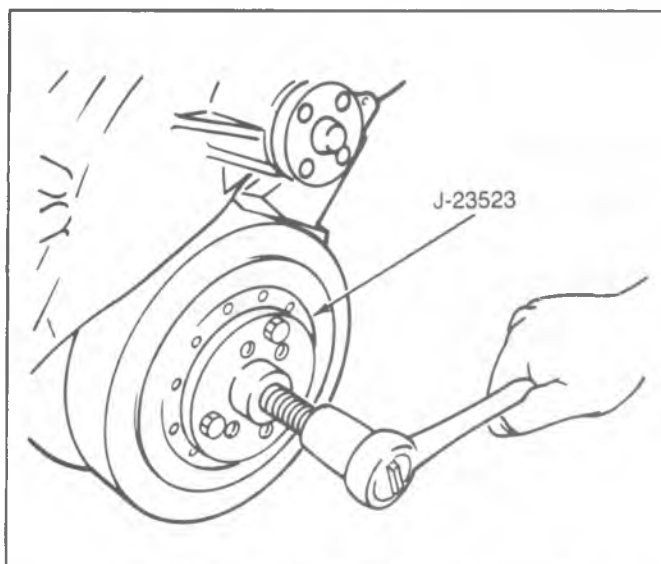

Fig. 32--Removing Torsional Damper - Typical

is refaced, a knife edge will be ground on part or all of the valve head due to the amount of metal that must be removed to completely reface. Knife edges lead to breakage, burning or pre-ignition due to heat localizing on this knife edge. If the edge of the valve head is less than 1/32" (.80mm) thick after grinding, replace the valve.

Several different types of equipment are available for refacing valves. The recommendation of the manufacturer of the equipment being used should be carefully followed to attain proper results.

## TORSIONAL DAMPER

### Removal

1. Remove fan belt, fan and pulley.
2. Remove the fan shroud assembly.
  - If additional operations (such as camshaft removal) are not being performed, radiator removal will not be necessary.
3. Remove accessory drive pulley then remove damper retaining bolt.
4. Install Tool J-23523 on damper then, turning puller screw, remove damper (fig. 32).

### Installation

**NOTICE:** The inertial weight section of the torsional damper is assembled to the hub with a rubber type material. The installation procedures (with proper tool) must be followed or movement of the inertia weight section on the hub will destroy the tuning of the torsional damper.

1. Coat front cover seal contact area (on damper) with engine oil.
2. Place damper in position over key on crankshaft.
3. Pull damper onto crankshaft as follows:
  - a. Install appropriate threaded end of Tool J-23523 into crankshaft. Install tool in crankshaft so that at least 1/2" (13mm) of thread engagement is obtained.
  - b. Install plate, thrust bearing and nut to complete tool installation.

- c. Pull damper into position as shown in Figure 33.
- d. Remove tool from crankshaft then install damper retaining bolt and torque to specifications
4. Install accessory drive pulley.
5. Install fan shroud.
6. Install fan and pulley to water pump hub and tighten securely.
7. Install fan belt and adjust (see section 6B).
8. Fill cooling system (see section 6B) and check for leaks.

## CRANKCASE FRONT COVER

### Removal

1. Remove torsional damper as previously outlined.
2. Remove water pump (see section 6B).
3. Remove crankcase front cover attaching screws and remove front cover and gasket, then discard gasket.

### Installation

1. Clean gasket surface on block and crankcase front cover.
2. Use a sharp knife or other suitable cutting tool to remove any excess oil pan gasket material that may be protruding at the oil to engine block junction.
3. Apply a 1/8" (3mm) bead of RTV, #1052366 or equivalent, to the joint formed at the oil pan and cylinder block.
4. Coat the cover gasket with gasket sealant and place in position on cover.
5. Install cover-to-oil pan seal, lightly coat bottom of seal with engine oil, and position cover over crankshaft end.
6. Loosely install the cover-to-block upper attaching screws.
7. Tighten screws alternately and evenly while pressing downward on cover so that dowels in block are aligned with corresponding holes in cover. Position cover so that dowels enter holes in cover without binding. Do not force cover over dowels so that cover flange or holes are distorted.
8. Install remaining cover screws and torque to specifications.

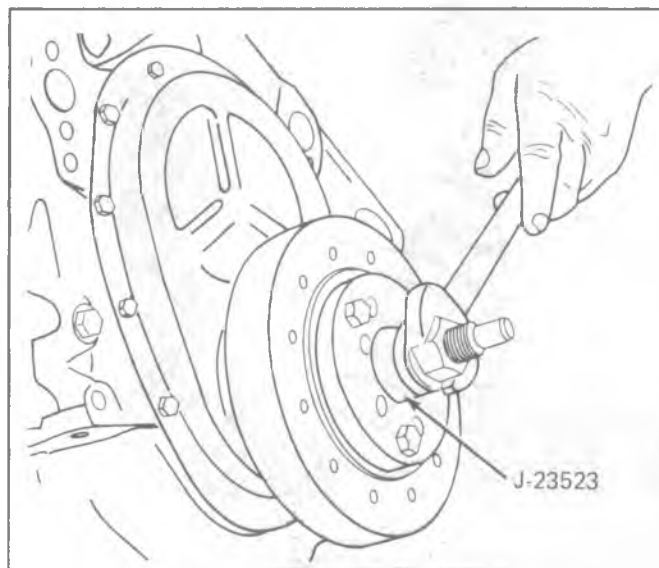

Fig. 33--Installing Torsional Damper



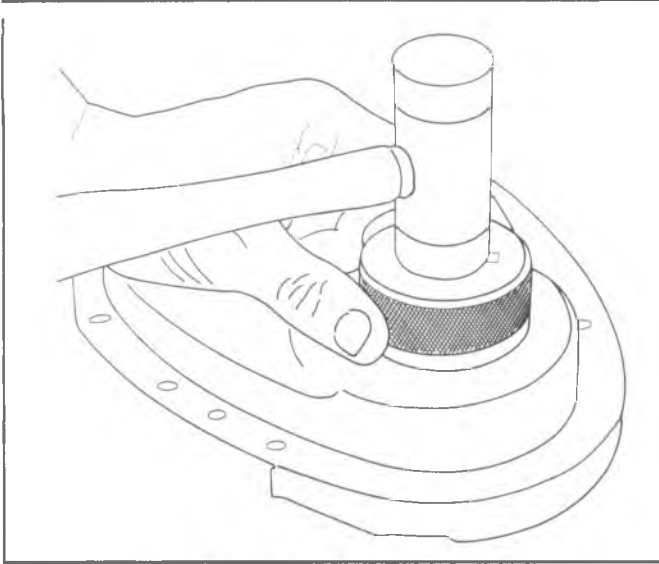

Fig. 34--Installing Oil Seal

9. Install torsional damper and water pump as previously outlined.

**OIL SEAL (FRONT COVER)**

**Replacement**

**With Cover Removed**

1. With cover removed, pry oil seal out of cover from the front with a large screw driver.
2. Install new seal so that open end of the seal is toward the inside of cover and drive it into position with Tool J-23042. Support rear of cover at seal area.

**With Cover Installed**

1. With torsional damper removed, pry seal out of cover from the front with a large screw driver. Be

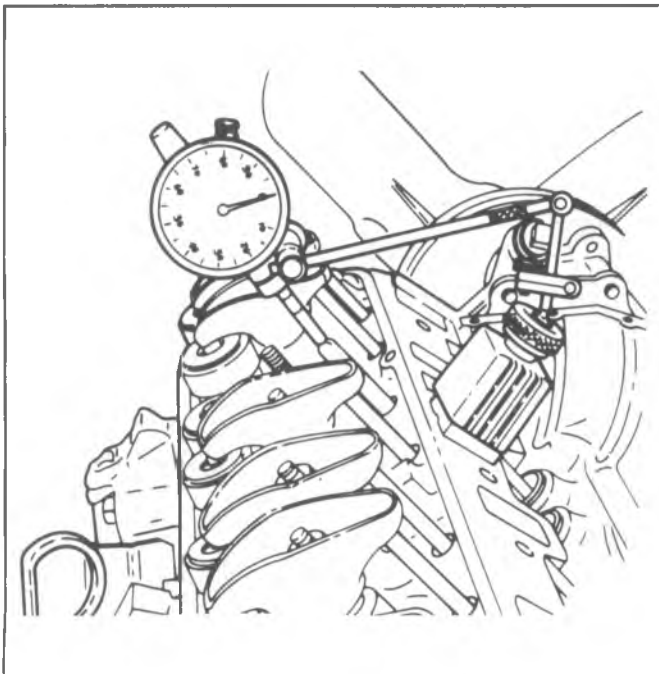

Fig. 35--Measuring Camshaft Lobe Lift

careful not to damage the surface on the crankshaft.

2. Install new seal so that open end of seal is toward the inside of cover and drive it into position with Tool J-23042 (fig. 34).

**CAMSHAFT**

**Measuring Lobe Lift**

1. Remove the valve mechanism as previously outlined.
2. Position indicator with ball socket adapter (Tool J-8520) on push rod (fig. 35). Make sure push rod is in the lifter socket.
3. Rotate the crankshaft slowly in the direction of rotation until the lifter is on the heel of the cam lobe. At this point, the push rod will be in its lowest position.
4. Set dial indicator on zero, then rotate the crankshaft slowly, or attach an auxiliary starter switch and "bump" the engine over, until the push rod is fully raised position.
  - Whenever the engine is cranked remotely at the starter, with a special jumper cable or other means, the distributor primary lead should be disconnected from the distributor (coil).
5. Compare the total lift recorded from the dial indicator with specifications.
6. If camshaft readings for all lobes are within specifications, remove dial indicator assembly.
7. Install and adjust valve mechanism as outlined.

**Removal**

1. Remove valve lifters as previously outlined.
2. Remove crankcase front cover as previously outlined.
3. Remove grille.
4. Remove fuel pump and push rod (see section 6C).
5. Complete camshaft removal as follows:
  - Sprocket is a light fit on camshaft. If sprocket does not come off easily a light blow on the lower edge of the sprocket (with a plastic mallet) should dislodge the sprocket.

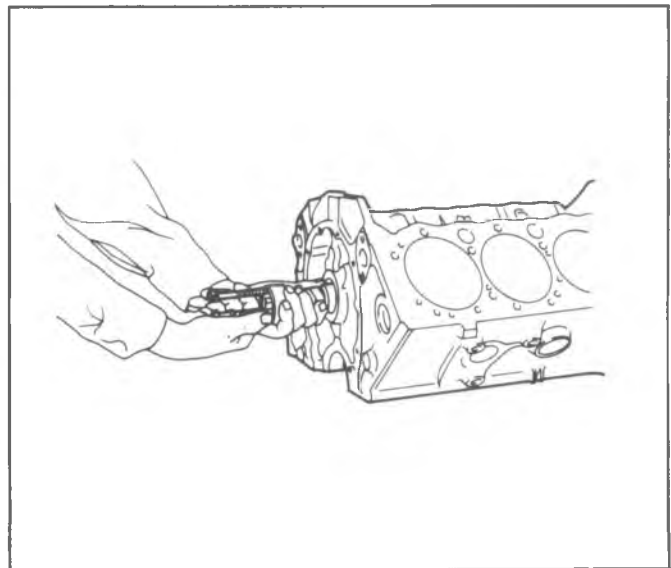

Fig. 36--Removing Camshaft

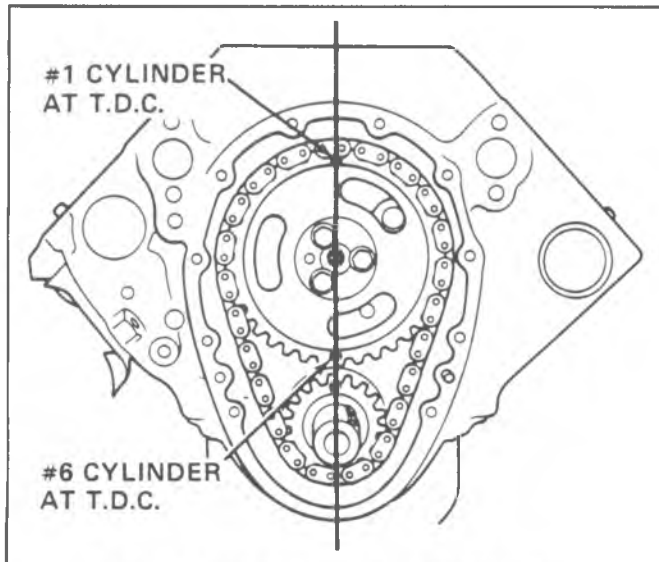

Fig. 37--Camshaft Sprocket Alignment Marks

6. Install two 5/16" - 18 x 4" bolts in camshaft bolt holes then remove camshaft (fig. 36).

**NOTICE:** All camshaft journals are the same diameter and care must be used in removing camshaft to avoid damage to bearings.

#### Inspection

The camshaft bearing journals should be measured with a micrometer for an out-of-round condition. If the journals exceed .001" (.025mm) out-of-round, the camshaft should be replaced.

#### Installation

Whenever a new camshaft is installed coat camshaft lobes with "Molykote" or its equivalent.

Whenever a new camshaft is installed, replacement of all valve lifters oil filter, and new oil is recommended to insure durability of the camshaft lobes and lifter feet.

1. Lubricate camshaft journals with engine oil and install camshaft.
2. Install timing chain on camshaft sprocket (fig. 37). Hold the sprocket vertically with the chain hanging down and align marks on camshaft and crankshaft sprockets.
3. Align dowel in camshaft with dowel hole in camshaft sprocket then install sprocket on camshaft.
4. Draw the camshaft sprocket onto camshaft using the mounting bolts. Torque to specifications.
5. Lubricate timing chain with engine oil.
6. Install fuel pump push rod and fuel pump (see section 6C).
7. Install grille.
8. Install crankcase front cover as previously outlined.
9. Install valve lifters as previously outlined.

## CAMSHAFT BEARINGS

#### Removal

Camshaft bearings can be replaced with engine completely or partially disassembled. To replace bearings without complete disassembly, remove the camshaft and

crankshaft leaving cylinder heads attached and pistons in place. Before removing crankshaft, tape threads of connecting rod bolts to prevent damage to crankshaft. Fasten connecting rods against sides of engine so they will not be in the way while replacing camshaft bearings.

1. With camshaft and crankshaft removed, drive camshaft rear plug from cylinder block.
2. Using Tool J-6098, with nut and thrust washer installed to end of threads, index pilot in camshaft front bearing and install puller screw through pilot.
3. Install remover and installer tool with shoulder toward bearing, making sure a sufficient amount of threads are engaged.
4. Using two wrenches, hold puller screw while turning nut. When bearing has been pulled from bore, remove remover and installer tool and bearing from puller screw (fig. 38).
5. Remove remaining bearings (except front and rear) in the same manner. It will be necessary to index pilot in camshaft rear bearing to remove the rear intermediate bearing.
6. Assemble remover and installer tool on driver handle and remove camshaft front and rear bearings by driving towards center of cylinder block (fig. 39).

#### Installation

The camshaft front and rear bearings should be installed first. These bearings will act as guides for the pilot and center the remaining bearings being pulled into place.

1. Assemble remover and installer tool on driver handle and install camshaft front and rear bearings by driving towards center of cylinder block (fig. 39).
2. Using Tool Set J-6098, with nut then thrust washer installed to end of threads, index pilot in camshaft front bearing and install puller screw through pilot.
3. Index camshaft bearing in bore (with oil hole aligned as outlined below), then install remover and installer tool on puller screw with shoulder toward bearing.
  - Number one cam bearing oil hole must be

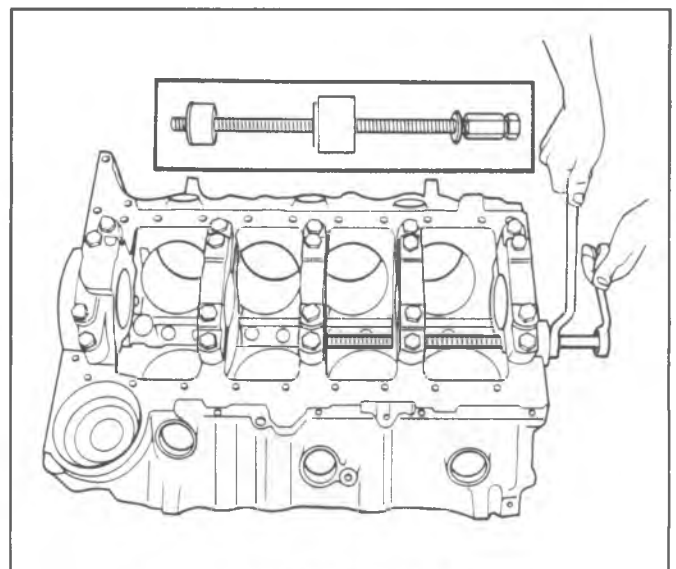

Fig. 38--Removing Camshaft Bearings

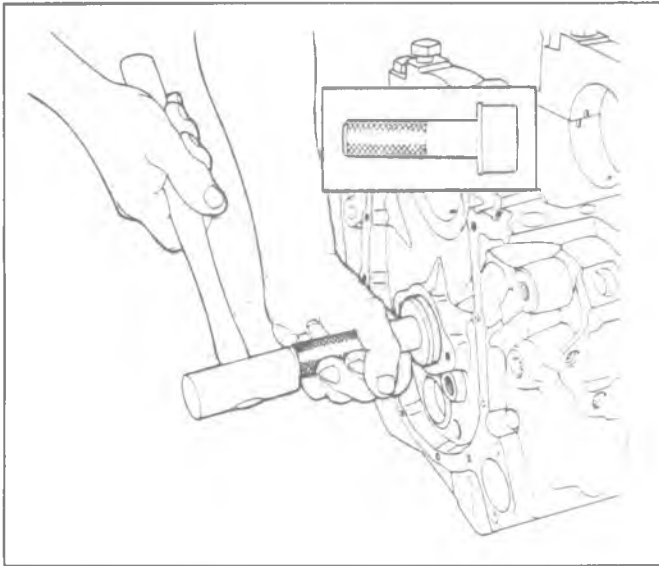

Fig. 39--Replacing Camshaft Front Bearing

positioned so that oil holes are equidistant from 6 o'clock position.

- Number two through number four bearing oil holes must be positioned at 5 o'clock position (toward left side of engine, and at a position even with bottom of cylinder bore).
  - Number five bearing oil hole must be in 12 o'clock position.
4. Using two wrenches, hold puller screw while turning nut. After bearing has been pulled into bore, remove the remover and installer tool from puller screw, and check alignment of oil hole in camshaft bearing.
  5. Install remaining bearings in the same manner. It will be necessary to index pilot in the camshaft rear bearing to install the rear intermediate bearing.
  6. Coat new camshaft rear plug O.D. with #1052080 sealant, or equivalent, and install flush to 1/32" (.80mm) deep.

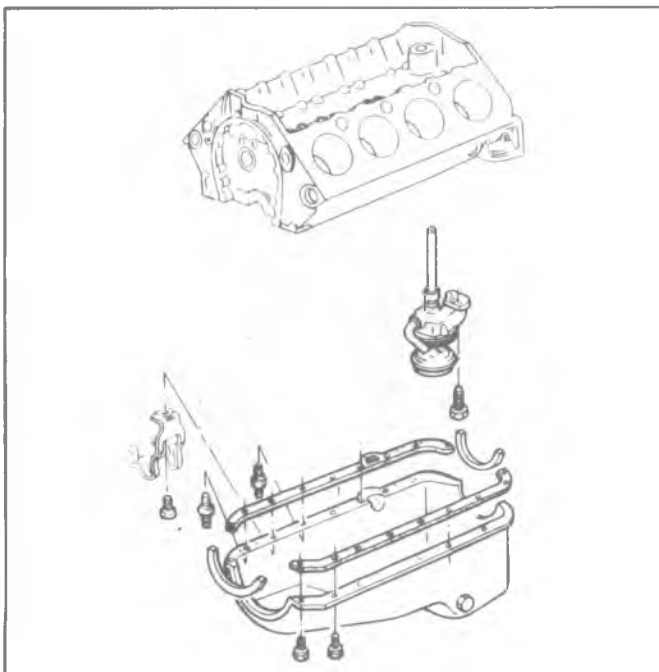

Fig. 40 -- Oil Pan

## OIL PAN (FIG. 40)

### Removal

1. Drain engine oil.
2. Remove exhaust crossover pipe.
3. On vehicles equipped with automatic transmission, remove converter housing under pan.
4. On 'K' models with automatic transmission, remove strut rods at motor mounts.
5. Remove oil pan and discard gaskets and seals.

### Installation

1. Thoroughly clean all gasket and seal surfaces on oil pan, cylinder block, crankcase front cover and rear main bearing cap.
2. Install new oil pan side gaskets on cylinder block using gasket sealant as a retainer. Install new oil pan rear seal in rear main bearing cap groove, with ends butting side gaskets. Install new oil pan front seal in groove in crankcase front cover with ends butting side gaskets.
3. Install oil pan and torque bolts to specifications.
4. If 'K' model, replace strut rods.
5. Install converter housing under pan.
6. Install exhaust crossover pipe.
7. Fill with oil, start engine and check for leaks.

## OIL PUMP

### Removal

1. Remove oil pan as previously outlined.
2. Remove pump to rear main bearing cap bolt and remove pump and extension shaft.

### Disassembly (Figure 38)

1. Remove the pump cover attaching screws and the pump cover.

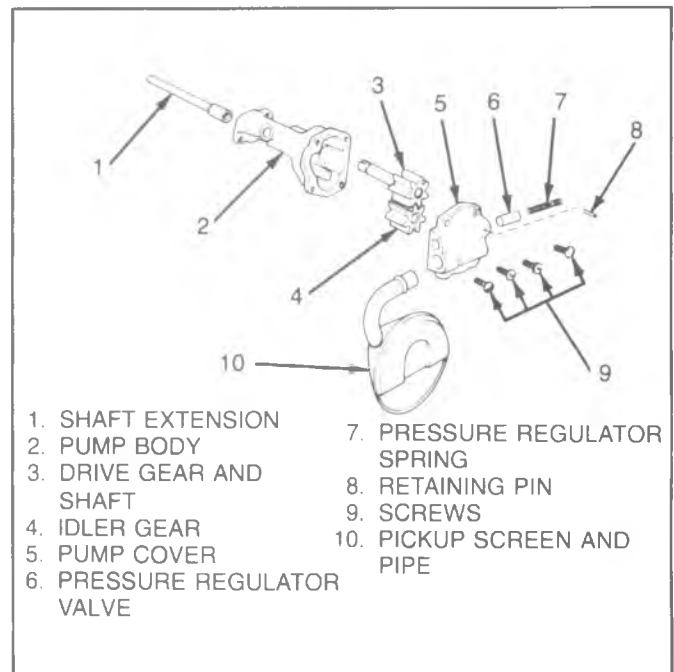

Fig. 41--Oil Pump

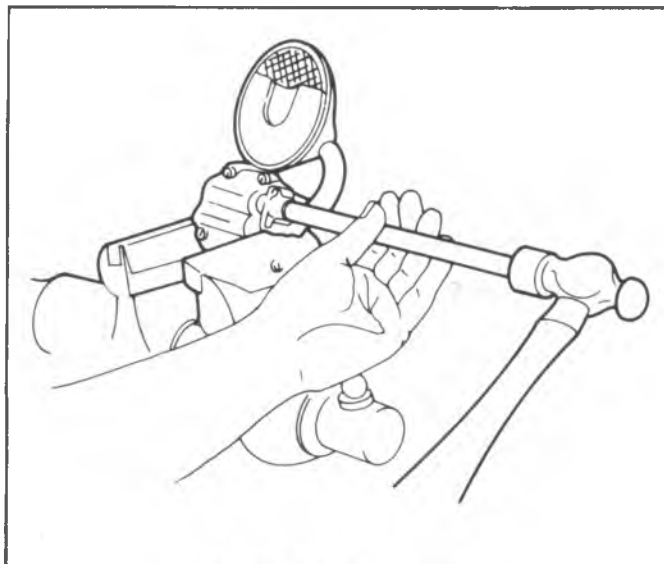

Fig. 42--Installing Screen

2. Mark gear teeth so they may be reassembled with the same teeth indexing. Remove the idler gear and the drive gear and shaft from the pump body.
3. Remove the pressure regulator valve retaining pin, pressure regulator valve and related parts.
4. If the pickup screen and pipe assembly need replacing, mount the pump in a soft-jawed vise and extract pipe from pump. Do not disturb the pickup screen on the pipe. This is serviced as an assembly.

#### Cleaning and Inspection

1. Wash all parts in cleaning solvent and dry with compressed air.
2. Inspect the pump body and cover for cracks or excessive wear.
3. Inspect pump gears for damage or excessive wear.
  - The pump gears and body are not serviced separately. If the pump gears or body are damaged or worn, replacement of the entire oil pump assembly is necessary.
4. Check the drive gear shaft for looseness in the pump body.
5. Inspect inside of pump cover for wear that would permit oil to leak past the ends of the gears.
6. Inspect the pickup screen and pipe assembly for damage to screen, pipe or relief grommet.
7. Check the pressure regulator valve for fit.

#### Assembly (Figure 41)

1. If the pickup screen and pipe assembly was removed, it should be replaced with a new part. Loss of press fit condition could result in an air leak and loss of oil pressure. Mount the pump in a soft-jawed vise, apply sealer to end of pipe, and using Tool J-8369 (fig. 42) tap the pipe in place with a plastic hammer.

**NOTICE:** Be careful of twisting, shearing or collapsing pipe while installing in pump.

2. Install the pressure regulator valve and related parts.

3. Install the drive gear and shaft in the pump body.
4. Install the idler gear in the pump body with the smooth side of gear towards pump cover opening.
5. Install the pump cover and torque attaching screws to specifications.
6. Turn drive shaft by hand to check for smooth operation.

#### Installation

1. Assemble pump and extension shaft to rear main bearing cap, aligning slot on top end of extension shaft with drive tang on lower end of distributor drive shaft.
2. Install pump to rear bearing cap bolt and torque to specifications.
3. Install oil pan previously outlined.

#### CONNECTING ROD BEARINGS

Connecting rod bearings are of the precision insert type and do not utilize shims for adjustment. **DO NOT FILE RODS OR ROD CAPS.** If clearances are found to be excessive a new bearing will be required. Service bearings are available in standard size and .001" and .002" undersize for use with new and used standard size crankshafts, and in .010" and .020" undersize for use with reconditioned crankshafts.

On removing a connecting rod cap, it is possible to find a .009" undersize bearing. These are used in manufacturing for selective fitting.

#### Inspection and Replacement

1. With oil pan and oil pump removed, remove the connecting rod cap and bearing.
 

Before removal of connecting rod cap, mark the side of the rod and cap with the cylinder number to assure matched reassembly of rod and cap.
2. Inspect the bearing for evidence of wear or damage. (Bearings showing the above should not be installed.)
3. Wipe both upper and lower bearing shells and crankpin clean of oil.

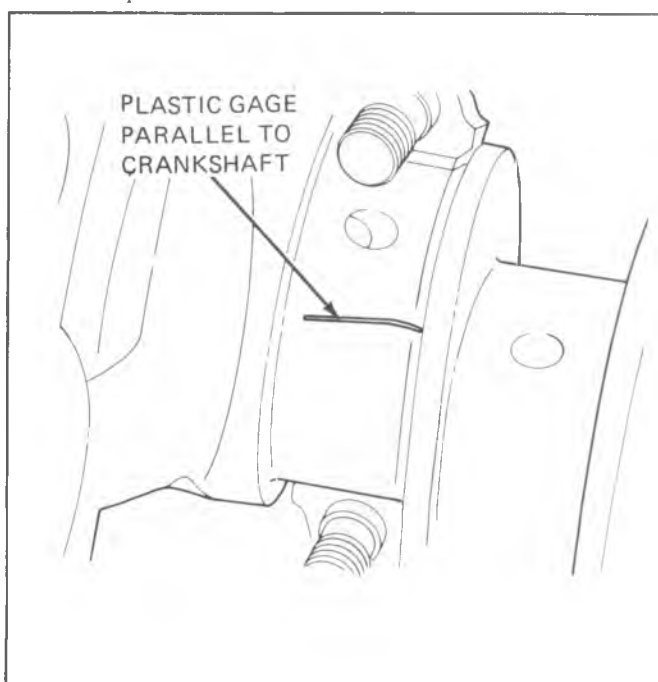

Fig. 43--Gaging Plastic On Crankpin

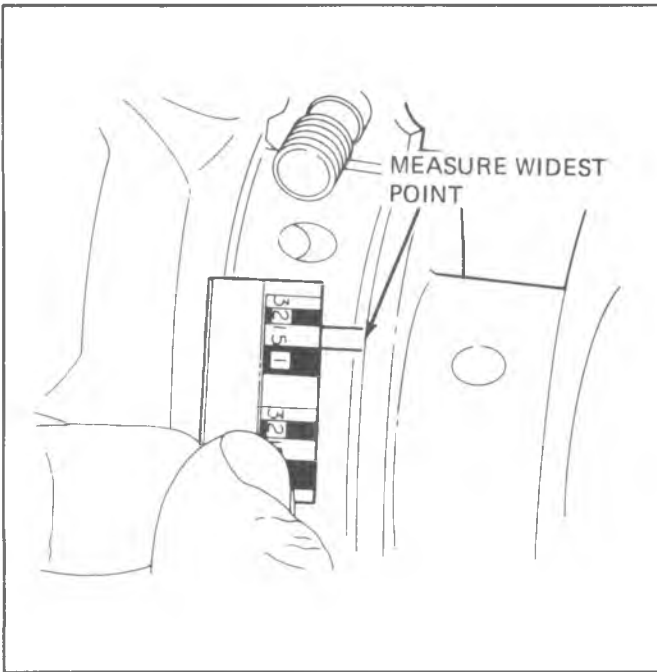

Fig. 44--Measuring Gaging Plastic

4. Measure the crankpin for out-of-round or taper with a micrometer. If not within specifications replace or recondition the crankshaft. If within specifications and a new bearing is to be installed, measure the maximum diameter of the crankpin to determine new bearing size required.
5. If within specifications measure new or used bearing clearances with Plastigage or its equivalent.  
If a bearing is being fitted to an out-of-round crankpin, be sure to fit to the maximum diameter of the crankpin. If the bearing is fitted to the minimum diameter and the crankpin is out-of-round .001" interference between the bearing and crankpin will result in rapid bearing failure.
  - a. Place a piece of gaging plastic, the length of the bearing (parallel to the crankshaft), on the crankpin or bearing surface (fig. 43). Plastic gage should be positioned in the middle of upper or lower bearing shell. (Bearings are eccentric and false readings could occur if placed elsewhere).
  - b. Install the bearing in the connecting rod and cap.
  - c. Install the bearing cap and evenly torque nuts to specifications.  
Do not turn the crankshaft with the gaging plastic installed.
  - d. Remove the bearing cap and using the scale on the gaging plastic envelope, measure the gaging plastic width at the widest point (fig. 44).
6. If the clearance exceeds specifications, select a new, correct size, bearing and remeasure the clearance.

Be sure to check what size bearing is being removed in order to determine proper replacement size bearing. If clearance cannot be brought to within specifications, the crankpin will have to be ground undersize. If the

crankpin is already at maximum undersize, replace crankshaft.

7. Coat the bearing surface with oil, install the rod cap and torque nuts to specifications.
8. When all connecting rod bearings have been installed tap each rod lightly (parallel to the crankpin) to make sure they have clearance.
9. Measure all connecting rod side clearances (see specifications) between connecting rod caps (fig. 45).

### MAIN BEARINGS

Main bearings are of the precision insert type and do not utilize shims for adjustment. If clearances are found to be excessive, a new bearing, both upper and lower halves, will be required. Service bearings are available in standard size and .001", .002", .009", .010" and .020" undersize.

Selective fitting of both rod and main bearing inserts is necessary in production in order to obtain close tolerances. For this reason you may find one half of a standard insert with one half of a .001" undersize insert which will decrease the clearance .0005" from using a full standard bearing.

When a production crankshaft cannot be precision fitted by this method, it is then ground .009" undersize **ON ONLY THOSE MAIN JOURNALS THAT CANNOT BE PROPERLY FITTED. ALL JOURNALS WILL NOT NECESSARILY BE GROUND.** A .009" undersize bearing or .010" undersize bearing will then be used for precision fitting in the same manner as previously described.

Identification of a reground crankshaft is by the following:

- The crankshaft throw will be stamped on one side of the undersize journal with "9", along with a large spot of green paint.
- The main bearing cap will be painted light green on each side of the affected journal.

If, for any reason, main bearing caps are replaced,



Fig. 45--Measuring Connecting Rod Side Clearance

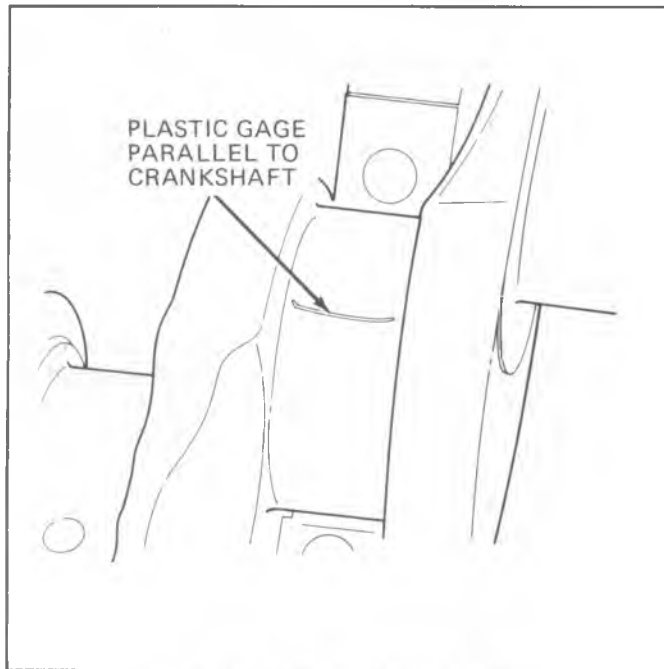

Fig. 46--Gaging Plastic on Journal

shimming may be necessary. Laminated shims for each cap are available for service. Shim requirement will be determined by bearing clearance.

#### Inspection

In general, the lower half of the bearing (except #1 bearing) shows a greater wear and the most distress from fatigue. If upon inspection the lower half is suitable for use, it can be assumed that the upper half is also satisfactory. If the lower half shows evidence of wear or damage, both upper and lower halves should be replaced. **NEVER REPLACE ONE HALF WITHOUT REPLACING THE OTHER HALF.**

#### Checking Clearance

To obtain the most accurate results with "Plastigage" (or its equivalent) a wax-like plastic material which will compress evenly between the bearing and journal surfaces without damaging either surface, certain precautions should be observed.

If the engine is out of the vehicle and upside down, the crankshaft will rest on the upper bearings and the total clearance can be measured between the lower bearing and journal. If the engine is to remain in the vehicle, the crankshaft must be supported upward to remove any clearance from the upper bearing. The total clearance can then be measured between the lower bearing and journal.

To assure the proper seating of the crankshaft, all bearing cap bolts should be at their specified torque. In addition, preparatory to checking fit of bearings, the surface of the crankshaft journal and bearing should be wiped clean of oil.

1. With the oil pan and oil pump removed, and starting with the rear main bearing, remove bearing cap and wipe oil from journal and bearing cap.
2. Place a piece of gaging plastic the full width of the bearing (parallel to the crankshaft) on the journal (fig. 46).

Do not rotate the crankshaft while the gaging plastic is between the bearing and journal.

3. Install the bearing cap and evenly torque the retaining bolts to specifications. Bearing cap **MUST** be torqued to specifications in order to assure proper reading. Variations in torque affect the compression of the plastic gage.
4. Remove bearing cap. The flattened gaging plastic will be found adhering to either the bearing shell or journal.
5. On the edge of gaging plastic envelope there is a graduated scale which is correlated in thousandths of an inch. Without removing the gaging plastic, measure its compressed width (at the widest point) with the graduations on the gaging plastic envelope (fig. 47).

Normally main bearing journals wear evenly and are not out-of-round. However, if a bearing is being fitted to an out-of-round (.001" max.), be sure to fit to the maximum diameter of the journal: If the bearing is fitted to the minimum diameter and the journal is out-of-round .001", interference between the bearing and journal will result in rapid bearing failure. If the flattened gaging plastic tapers toward the middle or ends, there is a difference in clearance indicating taper, low spot or other irregularity of the bearing or journal. Be sure to measure the journal with a micrometer if the flattened gaging plastic indicates more than .001" difference.

6. If the bearing clearance is within specifications, the bearing insert is satisfactory. If the clearance is not within specifications, replace the insert. Always replace both upper and lower inserts as a unit.

If a new bearing cap is being installed and clearance is less than .001", inspect for burrs or nicks; if none are found then install shims as required.

7. A standard, .001" or .002" undersize bearing may produce the proper clearance. If not, it will be necessary to regrind the crankshaft journal for use with the next undersize bearing.

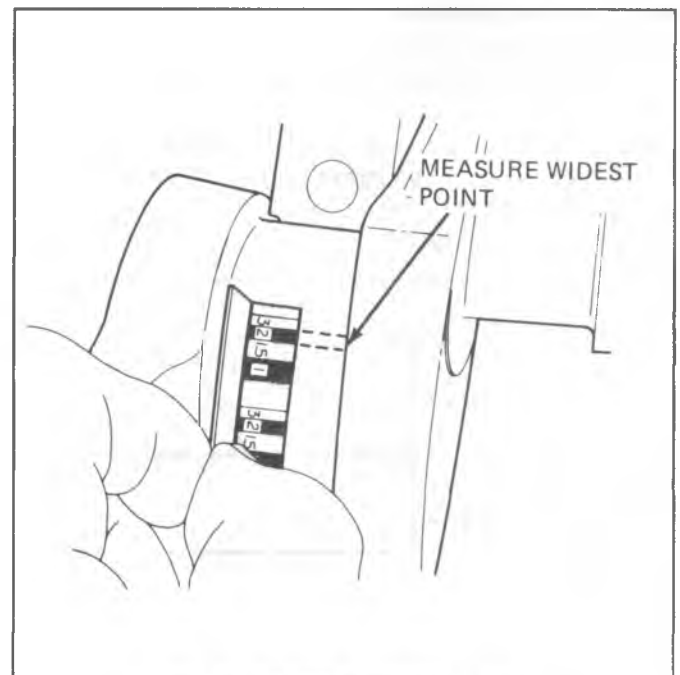

Fig. 47--Measuring Gaging Plastic

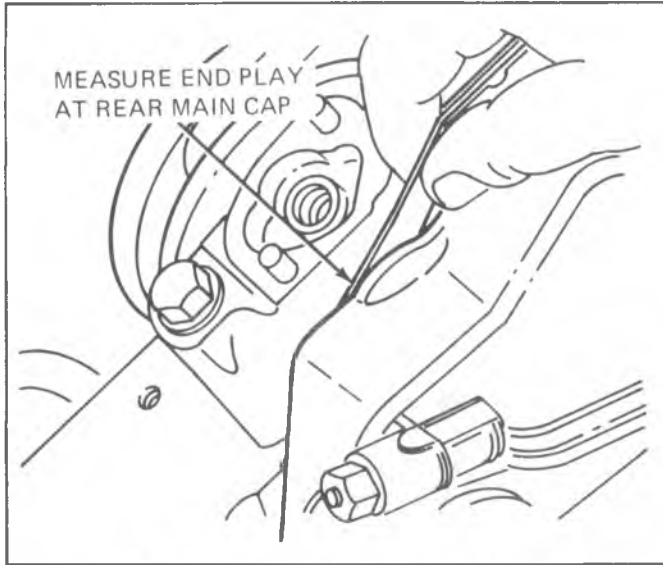

Fig. 48--Measuring Crankshaft End Play

After selecting new bearing, recheck clearance.

8. Proceed to the next bearing. After all bearings have been checked rotate the crankshaft to see that there is no excessive drag.  
When checking #1 main bearing, loosen accessory drive belts so as to prevent tapered reading with plastic gage.
9. Measure crankshaft end play (see specifications) by forcing the crankshaft to the extreme front position. Measure at the front end of the rear main bearing with a feeler gage (fig. 48).
10. Install a new rear main bearing oil seal in the cylinder block and main bearing cap.

#### Replacement

Main bearings may be replaced with or without removing the crankshaft.

#### With Crankshaft Removal

1. Remove and inspect the crankshaft.
2. Remove the main bearings from the cylinder block and main bearing caps.
3. Coat bearing surfaces of new, correct size, main bearings with oil and install in the cylinder block and main bearing caps.
4. Install the crankshaft.

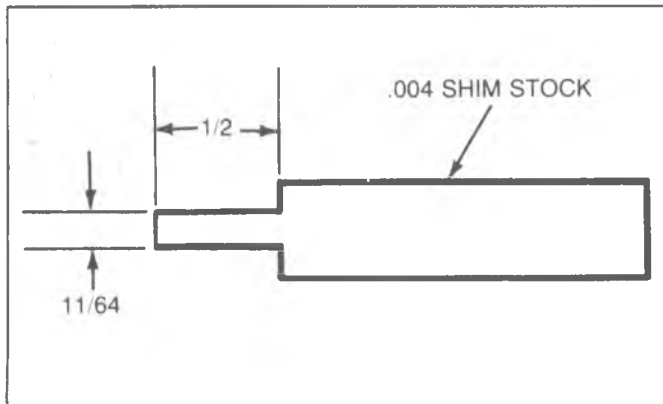

Fig. 49--Oil Seal Installation Tool

#### Without Crankshaft Removal

1. With oil pan, oil pump and spark plugs removed, remove cap on main bearing requiring replacement and remove bearing from cap.
2. Install a main bearing removing and installing tool in oil hole in crankshaft journal. If such a tool is not available, a cotter pin may be bent as required to do the job.
3. Rotate the crankshaft clockwise as viewed from the front of engine. This will roll upper bearing out of block.
4. Oil new selected size upper bearing and insert plain (unnotched) end between crankshaft and indented or notched side of block. Rotate the bearing into place and remove tool from oil hole in crankshaft journal.
5. Oil new lower bearing and install in bearing cap.
6. Install main bearing cap with arrows pointing toward front of engine.
7. Torque all main bearing caps EXCEPT THE REAR MAIN CAP to specifications. Torque rear main bearing cap to 10-12 lb. ft. (14-16N·m) then tap end of crankshaft, first rearward then forward with a lead hammer. This will line up rear main bearing and crankshaft thrust surfaces. Retorque all main bearing caps to specifications.

#### OIL SEAL (REAR MAIN)

##### Replacement

- ALWAYS REPLACE THE UPPER AND LOWER SEAL AS A UNIT.

The rear main bearing oil seal can be replaced (both halves) without removal of the crankshaft. Extreme care should be exercised when installing this seal to protect the sealing bead located in the channel on the outside diameter of the seal. An installation tool (fig. 49) must be used to protect the seal bead when positioning seal as follows:

1. With the oil pan and oil pump removed, remove the rear main bearing cap.
2. Remove oil seal from the bearing cap by prying from the bottom with a small screw driver (fig. 50).

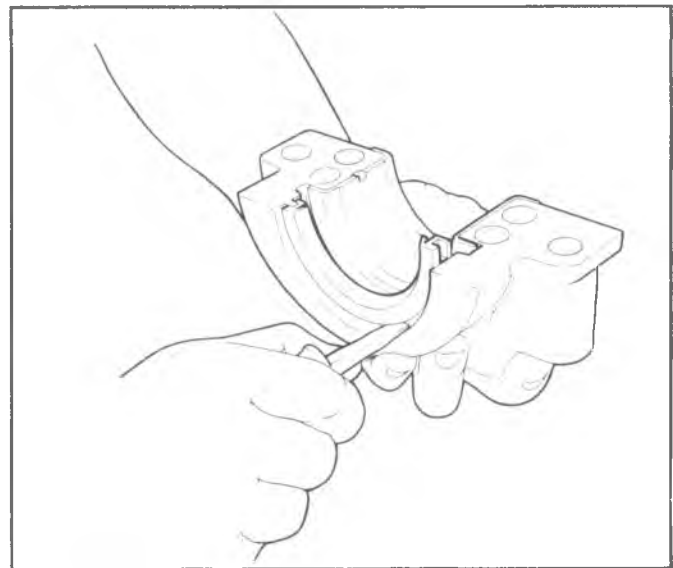

Fig. 50--Removing Oil Seal - Lower Half



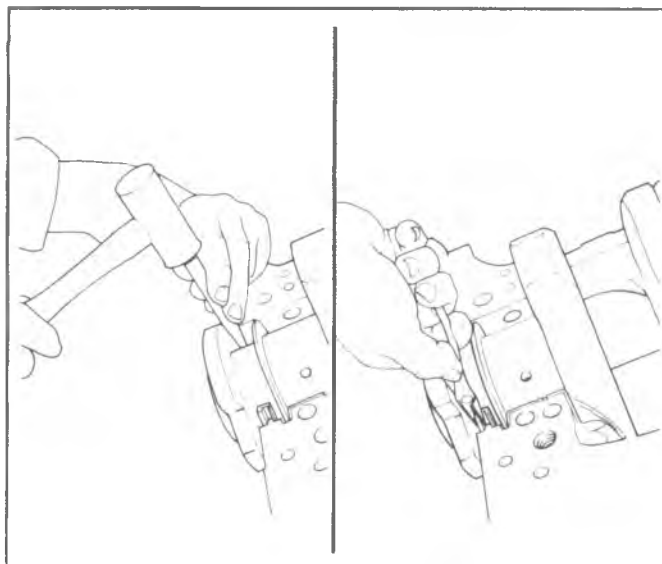

Fig. 51--Removing Oil Seal - Upper Half

3. To remove the upper half of the seal, use a small hammer to tap a brass pin punch on one end of seal until it protrudes far enough to be removed with pliers (fig. 51).
4. Clean all sealant and foreign material from cylinder case bearing cap and crankshaft, using a non-abrasive cleaner.
5. Inspect components for nicks, scratches, burrs and machining defects at all sealing surfaces, case assembly and crankshaft.
6. Coat seal lips and seal bead with light engine oil - keep oil off seal mating ends.
7. Position tip of tool between crankshaft and seal seat in cylinder case.
8. Position seal between crankshaft and tip of tool so that seal bead contacts tip of tool. Make sure that oil-seal lip is positioned toward front of engine (fig. 52).
9. Roll seal around crankshaft using tool as a "shoe-horn" to protect seal bead from sharp

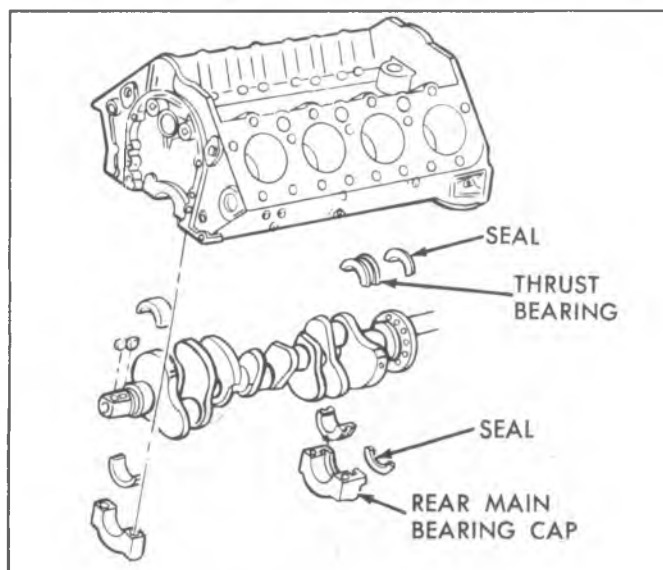

Fig. 52--Crankshaft Oil Seal - Rear Main

corner of seal seat surface in cylinder case. Installation tool must remain in position until seal is properly positioned with both ends flush with block.

10. Remove tool, being careful not to withdraw seal.
11. Install seal half in bearing cap, again using tool as a "shoe-horn", feeding seal into cap using light pressure with thumb and finger.
12. Install bearing cap to case with sealant applied to the cap-to-case interface being careful to keep sealant off the seal split line (fig. 53).
13. Install the rear main bearing cap (with new seal) and torque to 10-12 lb. ft. (14-16N·m). Tap end of crankshaft rearward then forward with lead hammer. This will line up thrust surfaces. Retorque bearing cap to specifications.

## CONNECTING ROD AND PISTON ASSEMBLIES

### Removal

1. Remove oil pan, oil pump and cylinder head as previously outlined.
2. For the cylinder being serviced turn crankshaft until piston is at the bottom of the stroke. Place a cloth on top of the piston.
3. Use a ridge reamer to remove any ridge and/or deposits from the upper end of the cylinder bore.
4. Turn crankshaft until piston is at top of stroke and remove cloth and cuttings.
5. Remove connecting rod cap and install Tool J-5239 (3/8") on studs. Push connecting rod and piston assembly out of top of cylinder block (fig. 54). It will be necessary to turn the crankshaft slightly to disconnect some of the connecting rod and piston assemblies and push them out of the cylinder.

### Disassembly

1. Remove connecting rod bearings from connecting rods and caps. If bearings are being reused, place them in a rack so they may be reinstalled in their original rod and cap.
2. Remove piston rings by expanding and sliding them off the pistons.

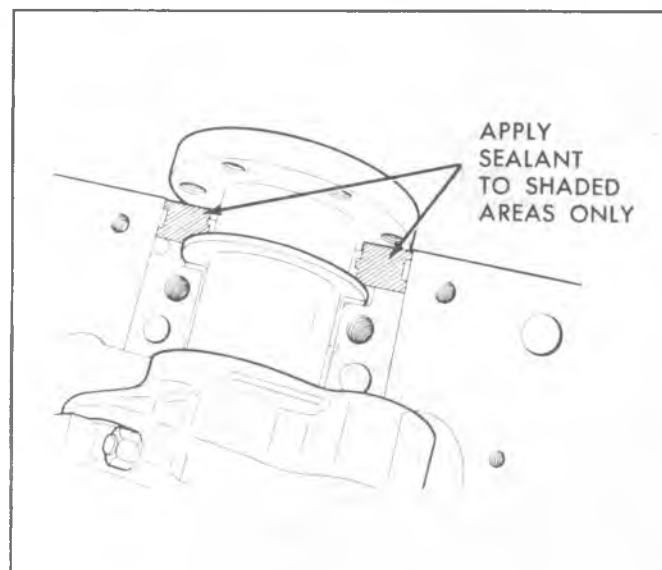

Fig. 53--Sealing Bearing Cap



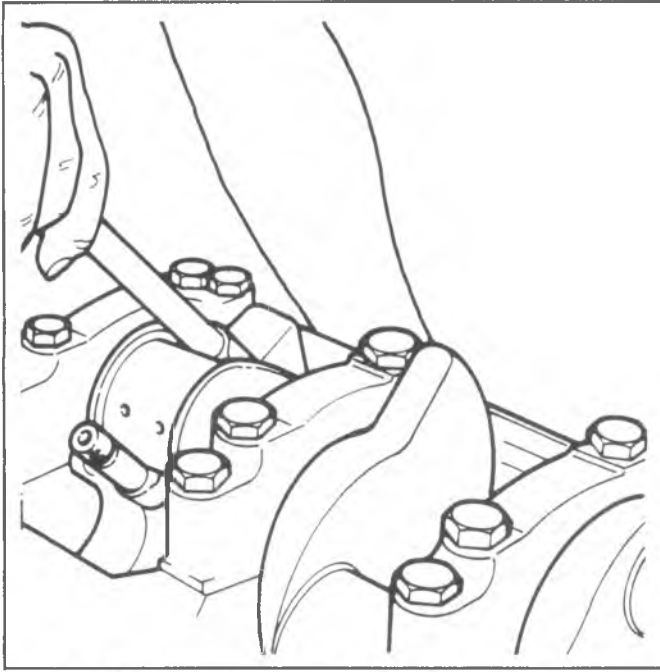

Fig. 54—Removing Connecting Rod &amp; Piston Assembly

- Place connecting rod and piston assembly on Tool J-24086-20. Using an arbor press and piston pin remover, J-24086-8, press the piston pin out of connecting rod and piston (fig. 55).

### Cleaning and Inspection

#### Connecting Rods

Wash connecting rods in cleaning solvent and dry with compressed air. Check for twisted or bent rods and inspect for nicks or cracks. Replace connecting rods that are damaged.

#### Pistons

Clean varnish from piston skirts and pins with a cleaning solvent. **DO NOT WIRE BRUSH ANY PART OF THE PISTON.** Clean the ring grooves with a groove cleaner and make sure oil ring holes and slots are clean.

Inspect the piston for cracked ring lands, skirts or pin bosses, wavy or worn ring lands, scuffed or damaged skirts, eroded areas at top of the piston. Replace pistons that are damaged or show signs of excessive wear.

Inspect the grooves for nicks or burrs that might cause the rings to hang up.

Measure piston skirt (across center line of piston pin) and check clearance.

#### Piston Pins

The piston pin clearance is designed to maintain adequate clearance under all engine operating conditions. Because of this, the piston and piston pin are a matched set and not serviced separately.

Inspect piston pin bores and piston pins for wear. Piston pin bores and piston pins must be free of varnish or scuffing when being measured. The piston pin should be measured with a micrometer and the piston pin bore should be measured with a dial bore gage or an inside micrometer. If

clearance is in excess of the .001" wear limit, the piston and piston pin assembly should be replaced.

### Assembly

- Lubricate piston pin holes in piston and connecting rod to facilitate installation of pin.
- Place connecting rod in piston and hold in place with piston pin guide and piston pin. Place assembly on fixture and support assembly.
- Using piston pin installer, J-24086-9, press the piston pin into the piston and connecting rod (fig. 56).

**NOTICE:** After installer hub bottoms on support assembly, do not exceed 5000 psi pressure, as this could cause structural damage to the tool.

- Remove piston and connecting rod assembly from tool and check piston for freedom of movement on piston pin.

### Piston Rings

All compression rings are marked on the upper side of the ring. When installing compression rings, make sure the **MARKED SIDE IS TOWARD THE TOP OF THE PISTON.** The top ring is chrome faced, or treated with molybdenum for maximum life. The second compression ring is a tapered face acting as both a compression and oil control ring.

The oil control rings are of three piece type, consisting of two segments (rails) and a spacer.

- Select rings comparable in size to the piston being used.
- Slip the compression ring in the cylinder bore; then press the ring down into the cylinder bore about 1/4" (6.5mm) (above ring travel). Be sure ring is square with cylinder wall.

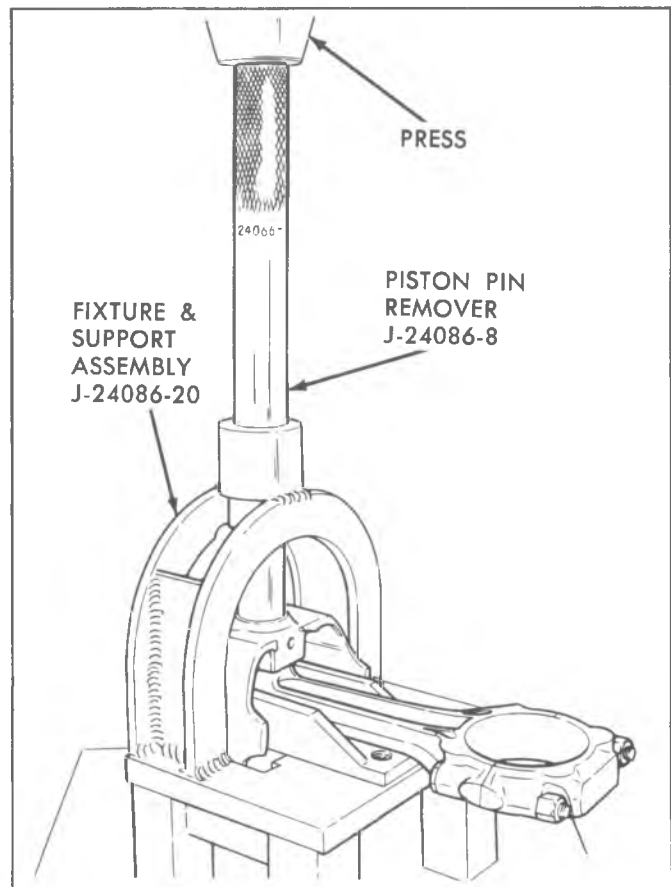

Fig. 55--Removing Piston Pin

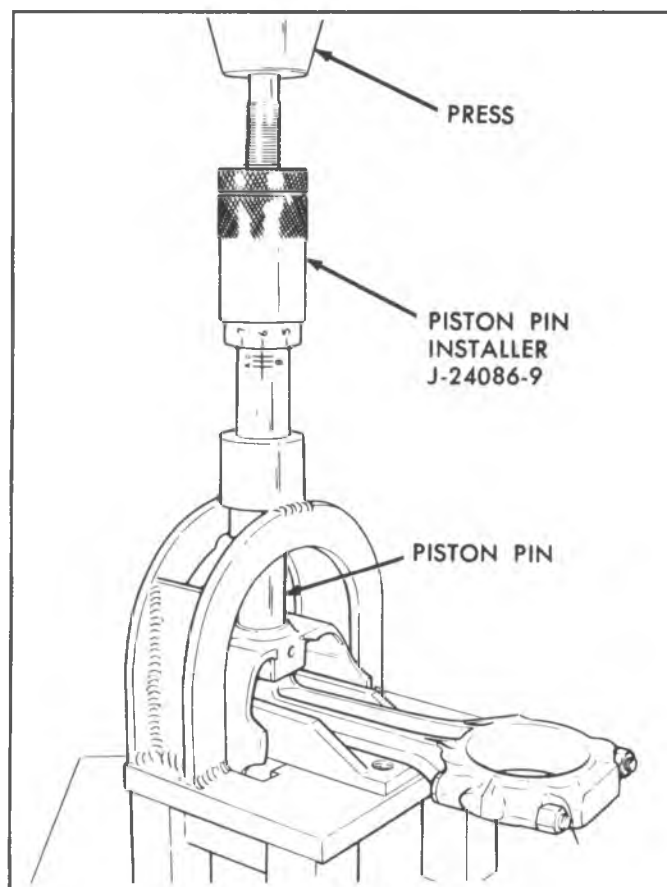

Fig. 56--Installing Piston Pin

3. Measure the space or gap between the ends of the ring with a feeler gage (fig. 57).
4. If the gap between the ends of the ring is below specifications, remove the ring and try another for fit.
5. Fit each compression ring to the cylinder in which it is going to be used.
6. If the pistons have not been cleaned and inspected as previously outlined, do so.

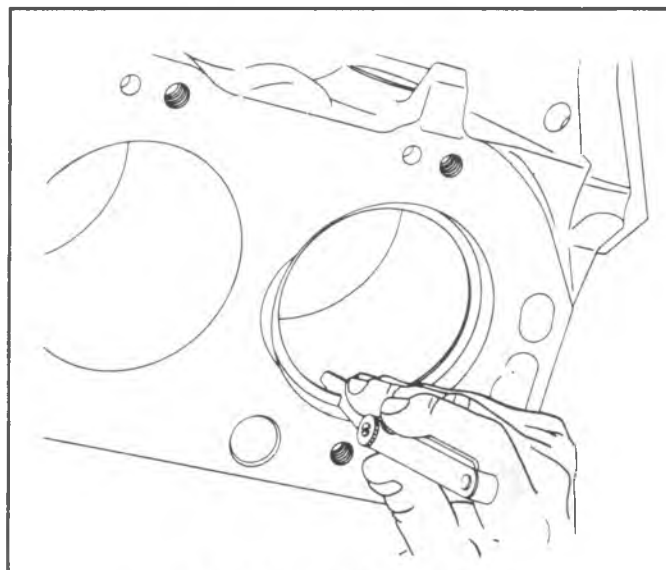

Fig. 57--Measuring Ring Gap

7. Slip the outer surface of the top and second compression ring into the respective piston ring groove and roll the ring entirely around the groove (fig. 58) to make sure that the ring is free. If binding occurs at any point, the cause should be determined. If binding is caused by ring groove, correct by dressing with a fine cut file. If the binding is caused by a distorted ring, check a new ring.
8. Install piston rings as follows:
  - a. Install oil ring spacer in groove and insert anti-rotation tang (where applicable) in drilled hole.
  - b. Hold spacer ends butted and install lower steel oil ring rail with gap properly located.
  - c. Install upper steel oil ring rail with gap properly located.
  - d. Flex the oil ring assembly to make sure ring is free. If binding occurs at any point the cause should be determined. If binding is caused by ring groove, correct by dressing groove with a fine cut file. If binding is caused by a distorted ring, check a new ring.
  - e. Install second compression ring (manufacturer mark up) with gaps properly located.
  - f. Install top compression ring (manufacturer mark up) with gap properly located.
9. Proper clearance of the piston ring in its piston ring groove is very important to provide proper ring action and reduce wear. Therefore, when fitting new rings, the clearances between the surfaces of the ring and groove should be measured (fig. 59). (See Specifications).

#### Installation

Cylinder bores must be clean before piston installation. This may be accomplished with a hot water and detergent wash or with a light honing as necessary. After cleaning, the bores should be swabbed several times with light engine oil and a clean dry cloth.

1. Lubricate connecting rod bearings and install in rods and rod caps.

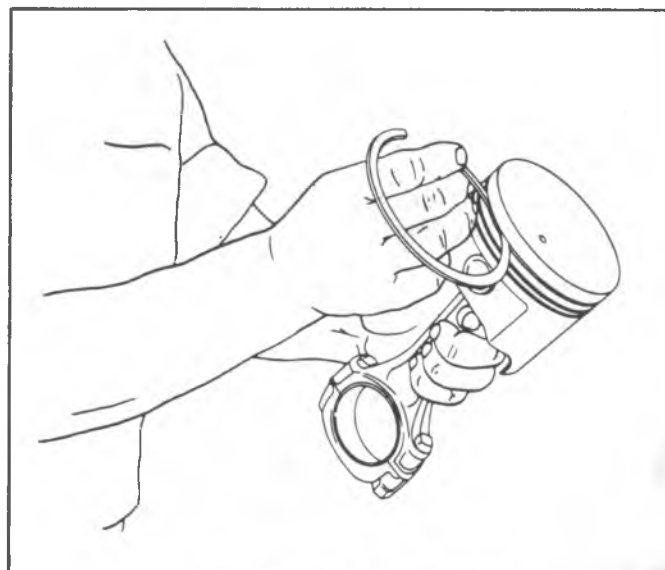

Fig. 58--Checking Ring in Groove



Fig. 59--Measuring Ring Groove Clearance

2. Lightly coat pistons, rings and cylinder walls with light engine oil.
3. With bearing caps removed, install Tool J-5239 (3/8") on connecting rod bolts.
4. Install each connecting rod and piston assembly in its respective bore. Install with connecting rod bearing tang slots on side opposite camshaft. Use Tool J-8037 to compress the rings (fig. 60). Guide the connecting rod into place on the crankshaft journal with Tool J-5239 (3/8") Use a hammer handle and light blows to install the piston into the bore. Hold the ring compressor firmly against the cylinder block until all piston rings have entered the cylinder bore.
5. Remove Tool J-5239.
6. Install the bearing caps and torque nuts to specifications.

Be sure to install new pistons in the cylinders for which they were fitted, and used pistons in the cylinder from which they were removed. Each connecting rod and bearing cap should be marked, beginning at the front of the engine. Cylinders 1,3,5 and 7 are the left bank and, 2, 4, 6 and 8 are the right bank. The numbers on the connecting rod and bearing cap must be on the same side when installed in the cylinder bore. If a connecting rod is ever transposed from one block or cylinder to another, new bearings should be fitted and the connecting rod should be numbered to correspond with the new cylinder number.

## CYLINDER BLOCK

### Cleaning and Inspection

1. Wash cylinder block thoroughly in cleaning solvent and clean all gasket surfaces.
2. Remove oil gallery plugs and clean all oil passages.
3. Clean and inspect coolant passages in the cylinder block.
4. Inspect the cylinder block for cracks in the cylinder walls, coolant jacket, valve lifter bores and main bearing webs.

5. Measure the cylinder walls for taper, out-of-round or excessive ridge at top of ring travel. This should be done with a dial indicator. Set the gage so that the thrust pin must be forced in about 1/4" (6.5mm) to enter gage in cylinder bore. Center gage in cylinder and turn dial to "0". Carefully work gage up and down cylinder to determine taper and turn it to different points around cylinder wall to determine the out-of-round condition. If cylinders were found to exceed specifications, honing or boring will be necessary.

### Conditioning

The performance of the following operation is contingent upon engine condition at time of repair.

If the cylinder block inspection indicated that the block was suitable for continued use except for out-of-round or tapered cylinders, they can be conditioned by honing or boring.

If the cylinders were found to have less than .005" (.13mm) taper or wear, they can be conditioned with a hone and fitted with the high limit standard size piston. A cylinder bore of less than .005" (.13mm) wear or taper may not entirely clean up when fitted to a high limit piston. If it is desired to entirely clean up the bore in these cases, it will be necessary to rebore for an oversize piston. If more than .005" (.13mm) taper or wear, they should be bored and honed to the smallest oversize that will permit complete resurfacing of all cylinders.

When pistons are being fitted and honing is not necessary, cylinder bores may be cleaned with a hot water and detergent wash. After cleaning, the cylinder bores should be swabbed several times with light engine oil and a clean cloth and then wiped with a clean dry cloth.

### Boring

1. Before using any type boring bar, the top of the cylinder block should be filed to remove any dirt or burrs. This is very important. If not checked, the boring bar may be tilted which would result in the rebored cylinder wall not being at right angles to the crankshaft.
2. The piston to be fitted should be measured with a micrometer, measuring at the center of the piston

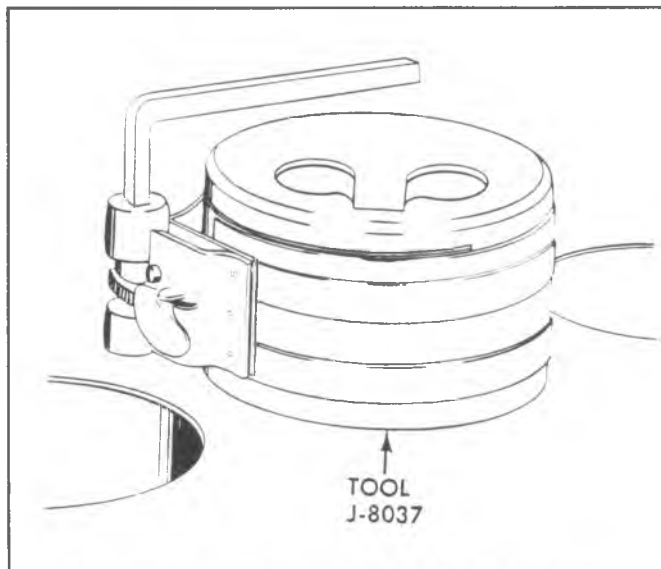

Fig. 60--Installing Connecting Rod Piston Assembly

skirt and at right angles to the piston pin. The cylinder should be bored to the same diameter as the piston and honed to give the specified clearance.

3. The instructions furnished by the manufacturer of the equipment being used should be carefully followed.

### Honing

1. When cylinders are to be honed, follow the hone manufacturer's recommendations for the use of the hone and cleaning and lubrication during honing.
2. Occasionally during the honing operation, the cylinder bore should be thoroughly cleaned and the piston selected for the individual cylinder checked for correct fit.
3. When finish honing a cylinder bore to fit a piston, the hone should be moved up and down at a sufficient speed to obtain very fine uniform surface finish marks in a cross-hatch pattern of approximately 45° to 65° included angle. The finish marks should be clean but not sharp, free from imbedded particles and torn or folded metal.
4. Permanently mark the piston for the cylinder to which it has been fitted and proceed to hone cylinders and fit the remaining pistons.

**NOTICE:** Handle the pistons with care and do not attempt to force them through the cylinder until the cylinder has been honed to correct size as this type piston can be distorted through careless handling.

5. Thoroughly clean the bores with hot water and detergent. Scrub well with a stiff bristle brush and rinse thoroughly with hot water. It is extremely essential that a good cleaning operation be performed. If any of the abrasive material is allowed to remain in the cylinder bores, it will rapidly wear the new rings and cylinder bores in addition to the bearings lubricated by the contaminated oil, the bores should be swabbed and then wiped with a clean dry cloth. Cylinder should not be cleaned with kerosene or gasoline. Clean the remainder of the cylinder block to remove the excess material spread during the honing operation.

### Piston Selection

1. Check USED piston to cylinder bore clearance as follows:
  - a. Measure the "Cylinder Bore Diameter" with a telescope gage 2-1/2" (64mm) from top of cylinder bore.
  - b. Measure the "Piston Diameter" (at skirt across center line of piston pin).
  - c. Subtract piston diameter from cylinder bore diameter to determine "Piston to Bore Clearance".
  - d. Locate piston to bore clearance and determine if piston to bore clearance is in the acceptable range.
2. If used piston is not acceptable, determine if a new piston can fit cylinder bore.
3. If cylinder bore must be reconditioned, measure new piston diameter (across center line of piston pin) then hone cylinder bore to correct clearance.
4. Mark the piston to identify the cylinder for which it was fitted.

## OIL FILTER BYPASS VALVE

### Inspection and Replacement

With the oil filter removed, check the spring and fibre valve for operation. Inspect for a cracked or broken valve. If replacement is necessary, the oil filter adapter and bypass valve assembly must be replaced as an assembly. Clean valve chamber in cylinder block thoroughly. Torque retaining screws to specifications.

## ENGINE ASSEMBLY

### Removal ("G" Van/Code U, L & R Engines)

1. Disconnect battery cables at battery.
2. Drain cooling system.
3. Remove coolant reservoir bottle.
4. Remove grille, upper radiator support and lower grille valance.
5. Disconnect radiator hoses at radiator.
  - If equipped with automatic transmission, remove cooler lines from radiator.
  - If equipped with A/C, evacuate system and remove condenser. Remove A/C vacuum reservoir.
6. Remove washer jar and bracket.
7. Remove radiator to radiator support attaching brackets and remove radiator and shroud.
8. If equipped with P/S, remove pump and lay aside.
9. Remove engine cover.
10. Remove air cleaner air stove pipe.
11. Remove accelerator cable from carburetor and remove carburetor.
12. Disconnect engine wiring harness from connection on firewall.
13. Disconnect heater hoses at engine.
14. Remove thermostat housing.
15. Remove oil fill pipe.
16. If equipped with cruise control, remove servo and bracket and transducer.
17. Raise vehicle.
18. Disconnect exhaust pipe from exhaust manifold flanges.
19. Remove propshaft; plug transmission end.
20. Disconnect transmission shift linkage and speedometer cable.
21. Disconnect fuel hose from fuel pump.
22. Remove transmission mount bolts.
23. Remove engine mount bracket to frame bolts.
24. Drain crankcase.
25. Remove engine mount "through" bolts.
26. Raise engine slightly and remove engine mounts. Block up engine with wood between oil pan and crossmember.
27. Lower vehicle and install lifting tool.
28. Remove engine/transmission assembly.

### Installation ("G" Van/Code U, L & R Engines)

1. Place engine/transmission assembly into vehicle. Support engine with blocks of wood between the oil pan and crossmembers.

2. Raise vehicle and install engine mounts. Retain by inserting engine mount "through" bolts.
3. Raise engine slightly, remove wooden blocks and lower engine onto mounts.
4. Install engine mount bracket to frame bolts. Torque to specifications.
5. Install transmission mount bolts. Torque to specifications.
6. Connect fuel tank line and return line to fuel pump.
7. Connect transmission shift linkage and speedometer cable.
8. Install propshaft.
9. Connect exhaust pipe to exhaust manifold flanges.
10. Lower vehicle.
11. Connect heater hoses.
12. Connect engine wiring harness.
13. Using a new gasket, install carburetor. Connect accelerator cable.
14. Install radiator. Install radiator to radiator support attaching brackets.
  - If equipped with automatic transmission, connect cooler lines to radiator.
  - If equipped with A/C, install condenser to radiator support.
15. Connect radiator hoses to radiator.
16. Install grille cross brace and grille.
17. Fill cooling system.
18. Fill crankcase with oil.
  - If equipped with A/C, mount compressor, connect hosing and charge system.
19. Connect battery cables and start engine. Check ignition timing and adjust carburetor if necessary.
20. Install air cleaner and engine cover.

#### Removal (CK Series/Code U, L & R Engines)

1. Disconnect battery cables at battery.
2. Drain cooling system.
3. Remove air cleaner.
4. Remove all accessory drive belts.
5. Remove fan and water pump pulley.
6. Disconnect upper and lower radiator hoses at engine.
7. Disconnect heater hoses at engine.
  - If equipped with automatic transmission, disconnect cooler lines at radiator.
8. Remove radiator and shroud.
9. Disconnect accelerator linkage and detent linkage, if so equipped, from carburetor.
10. If A/C equipped, remove compressor from engine and lay aside.
11. If power steering equipped, remove pump from engine and lay aside.
12. Remove engine wiring harness from engine.
13. Disconnect fuel line at fuel pump.
14. Disconnect all vacuum lines from intake manifold.
15. Raise vehicle.
16. Drain crankcase.
17. Disconnect exhaust pipe from exhaust manifold flanges.
  - 'K' models with automatic transmission, remove strut rods at motor mounts.
18. Remove flywheel or convertor splash shield, as applicable.
19. Disconnect wiring along right pan rail.
20. Disconnect wiring at starter and remove starter.
21. Disconnect wiring for gas gage.
22. If equipped with automatic transmission, remove convertor to flex plate attaching bolts.
23. Support transmission.
24. Remove bell housing to engine retaining bolts.
25. Remove lower engine mount bracket to frame bolts.
26. Lower vehicle.
27. Remove vehicle hood.
28. Attach engine lifting device.
29. Remove engine.

#### Installation (CK Series/Code U, L & R Engines)

1. Place engine in vehicle.
2. Raise vehicle.
3. Install engine mount bracket to frame bolts.
4. Install bell housing to engine retaining bolts. Remove transmission support.
5. If equipped with automatic transmission, install convertor to flex plate attaching bolts.
6. Install flywheel or convertor splash shield, as applicable.
7. Connect wiring for gas gage.
8. Install starter. Connect wiring.
9. Install engine wiring harness along right pan rail.
10. Connect exhaust pipe to exhaust manifold flanges.
11. Lower vehicle.
12. Connect all vacuum lines to intake manifold.
13. Connect fuel line at fuel pump.
14. Install engine wiring harness to engine.
15. If power steering equipped, install pump on engine.
16. If A/C equipped, install compressor on engine.
17. Connect accelerator linkage and detent linkage, if so equipped, to carburetor.
18. Install radiator.
  - If equipped with automatic transmission, connect cooler lines to radiator.
19. Connect heater hoses to engine.
20. Connect radiator hoses to engine.
21. Install water pump pulley and fan to water pump.
22. Install accessory drive belts. Adjust to specifications.
23. Fill cooling system.
24. Fill crankcase.
25. Connect battery cables and start engine. Check timing and carburetor adjustment and adjust if necessary.
26. Install air cleaner and vehicle hood.

## CRANKSHAFT

The crankshaft can be removed while the engine is disassembled for overhaul, as previously outlined, or without complete disassembly as outlined below.

### Removal

1. With the engine removed from the vehicle and the transmission and/or clutch housing removed from the engine, mount engine in stand and clamp securely.
2. Remove the oil dip stick and oil dip stick tube, (if applicable).
3. Remove the starting motor, clutch assembly (if equipped) and flywheel.
4. Remove the spark plugs.
5. Remove crankshaft pulley and torsional damper.
6. Remove oil pan and oil pump.
7. Remove crankcase front cover, and if so equipped, remove timing chain and camshaft sprocket.
8. Check the connecting rod caps for cylinder number identification. If necessary, mark them.
9. Remove the connecting rod caps and push the pistons to top of bores.
10. Remove main bearing caps and lift crankshaft out of cylinder block.
11. Remove rear main bearing oil seal and main bearings from cylinder block and main bearing caps.

### Cleaning and Inspection

1. Wash crankshaft in solvent and dry with compressed air.
2. Measure dimensions of main bearing journals and crankpins with a micrometer for out-of-round, taper or undersize. (See Specifications.)
3. Check crankshaft for run-out by supporting at the front and rear main bearings journals in "V" blocks and check at the front and rear intermediate journals with a dial indicator. (See Specifications.)
4. Replace or recondition the crankshaft if out of specifications.

## SPROCKET OR GEAR REPLACEMENT (REFER TO FIG. 61)

- Remove crankshaft sprocket using Tool J-5825, install using Tool J-5590.

### Installation

1. Install rear main bearing oil seal in cylinder block and rear main bearing cap grooves. Install with lip of seal toward front of engine. Where seal has two lips install lip with helix towards front of engine.
2. Lubricate lips of seal with engine oil. Keep oil off parting line surface.
3. Install main bearings in cylinder block and main bearing caps then lubricate bearing surface with engine oil.
4. Install crankshaft, being careful not to damage bearing surfaces.
5. Apply a thin coat of brush-on type oil sealing compound to block mating surface and corresponding surface of cap only. Do not allow sealant on crankshaft or seal.
6. Install main bearing caps with arrows pointing toward front of engine.
7. Torque all except rear main bearing cap bolts to specifications. Torque rear main bearing cap bolts to 10-12 lbs. ft. (14-16 N·m) then tap end of crankshaft, first rearward then forward with a lead hammer. This will line up rear main bearing and crankshaft thrust surfaces. Retorque all main bearing cap bolts to specifications.
8. Measure crankshaft end play with a feeler gage. Force crankshaft forward and measure clearance between the front of the rear main bearing and the crankshaft thrust surface.
9. Install flywheel and torque to specifications. A wood block placed between the crankshaft and cylinder block will prevent crankshaft from rotating.
  - Align dowel hole in flywheel with dowel hole in crankshaft. On vehicles equipped with automatic transmissions, install flywheel with the converter attaching pads towards transmission.

GENERAL DATA:

|                   |           |                    |     |       |                    |          |  |
|-------------------|-----------|--------------------|-----|-------|--------------------|----------|--|
| TYPE              |           | 90° V-8 GASOLINE   |     |       |                    |          |  |
| DISPLACEMENT      | LITRE (°) | 5.0 (F)<br>5.0 (H) |     |       | 5.7 (L)<br>5.7 (M) |          |  |
|                   |           | RPO                | LF3 |       | LE9                | LS9 /LT9 |  |
| BORE              |           | 3.736              |     |       | 4.000              |          |  |
| STROKE            |           | 3.480              |     |       |                    |          |  |
| COMPRESSION RATIO |           | 8.6:1              |     | 9.2:1 | 8.2:1              | 8.3:1    |  |
| FIRING ORDER      |           | 1-8-4-3-6-5-7-2    |     |       |                    |          |  |

CYLINDER BORE:

|              |            |               |            |               |  |
|--------------|------------|---------------|------------|---------------|--|
| DIAMETER     |            | 3.7350-3.7385 |            | 3.9995-4.0025 |  |
| OUT OF ROUND | PRODUCTION | .001 MAX.     |            |               |  |
|              | SERVICE    | .002 MAX.     |            |               |  |
| TAPER        | PRODUCTION | THRUST SIDE   | .0005 MAX. |               |  |
|              |            | RELIEF SIDE   | .001 MAX.  |               |  |
|              | SERVICE    | .001 MAX.     |            |               |  |

PISTON:

|           |            |             |  |
|-----------|------------|-------------|--|
| CLEARANCE | PRODUCTION | .0007-.0017 |  |
|           | SERVICE    | .0027 MAX.  |  |

PISTON RING:

|   |                  |            |                            |             |  |
|---|------------------|------------|----------------------------|-------------|--|
| C<br>O<br>M<br>P<br>R<br>E<br>S<br>S<br>I<br>O<br>N | GROOVE CLEARANCE | PRODUCTION | TOP                        | .0012-.0032 |  |
|   |                  |            | 2ND                        | .0012-.0032 |  |
|   |                  | SERVICE    | HI LIMIT PRODUCTION + .001 |             |  |
|   | GAP              | PRODUCTION | TOP                        | .010-.020   |  |
|   |                  |            | 2ND                        | .010-.025   |  |
|   |                  | SERVICE    | HI LIMIT PRODUCTION + .010 |             |  |
| O<br>I<br>L   | GROOVE CLEARANCE | PRODUCTION | .002-.007                  |             |  |
|   |                  | SERVICE    | HI LIMIT PRODUCTION + .001 |             |  |
|   | GAP              | PRODUCTION | .015-.055                  |             |  |
|   |                  | SERVICE    | HI LIMIT PRODUCTION + .010 |             |  |

VIN Designation

PISTON PIN

LF3, LE9

LS9/LT9

|            |            |                          |  |
|------------|------------|--------------------------|--|
| DIAMETER   |            | .9270-.9273              |  |
| CLEARANCE  | PRODUCTION | .00025-.00035            |  |
|            | SERVICE    | .001 MAX.                |  |
| FIT IN ROD |            | .0008-.0016 INTERFERENCE |  |

CRANKSHAFT

|                        |              |             |  |  |
|------------------------|--------------|-------------|--|--|
| MAIN JOURNAL           | DIAMETER     |             | #1 2.4484-2.4493                             |  |
|                        |              |             | #2-3-4 2.4481-2.4490                         |  |
|                        |              |             | #5 2.4479-2.4488                             |  |
|                        | TAPER        | PRODUCTION  | .0002 MAX.                                   |  |
|                        |              | SERVICE     | .001 MAX.                                    |  |
|                        | OUT OF ROUND | PRODUCTION  | .0002 MAX.                                   |  |
| SERVICE                |              | .001 MAX.   |  |  |
| MAIN BEARING CLEARANCE | PRODUCTION   |             | #1 .008-.0020                                |  |
|                        |              |             | #2-3-4 .0011-.0023                           |  |
|                        | SERVICE      |             | #1 .001-.0015 #2-4 .001-.0025 #5 .0025-.0035 |  |
| CRANKSHAFT END PLAY    |              |             | .002-.006                                    |  |
| CRANKPIN               | DIAMETER     |             | 2.0988-2.0998                                |  |
|                        | TAPER        | PRODUCTION  | .0005  |  |
|                        |              | SERVICE     | .001 MAX.                                    |  |
|                        | OUT OF ROUND | PRODUCTION  | .0005  |  |
|                        |              | SERVICE     | .001 MAX.                                    |  |
| ROD BEARING CLEARANCE  | PRODUCTION   | .0013-.0035 |  |  |
|                        | SERVICE      | .0030       |  |  |
| ROD SIDE CLEARANCE     |              |             | .008-.014                                    |  |

CAMSHAFT

|                     |         |               |       |
|---------------------|---------|---------------|-------|
| LOBE LIFT<br>± .002 | INTAKE  | .2484         | .2600 |
|                     | EXHAUST | .2667         | .2733 |
| JOURNAL DIAMETER    |         | 1.8682-1.8692 |       |
| CAMSHAFT END PLAY   |         | .004-.012     |       |

### VALVE SYSTEM

| LIFTER                   |                          | HYDRAULIC                               |                |
|--------------------------|--------------------------|---|----------------|
| ROCKER ARM RATIO         |                          | 1.50:1                                  |                |
| VALVE LASH               | INTAKE                   | ONE TURN DOWN FROM ZERO LASH            |                |
|                          | EXHAUST                  |   |                |
| FACE ANGLE (INT. & EXH.) |                          | 45°                                     |                |
| SEAT ANGLE (INT. & EXH.) |                          | 46°                                     |                |
| SEAT RUNOUT              |                          | .002 MAX.                               |                |
| SEAT WIDTH               | INTAKE                   | 1/32-1/16                               |                |
|                          | EXHAUST                  | 1/16-3/32                               |                |
| STEM CLEARANCE           | PRODUCTION               | INT.                                    | .0010-.0027    |
|                          |                          | EXH.                                    | .0010-.0027    |
|                          | SERVICE                  | HI LIMIT PROD. ± .001 INTAKE + .002 EXH |                |
| VALVE SPRING (OUTER)     | FREE LENGTH              |   | 2.03           |
|                          | PRESSURE LBS. @ IN.      | CLOSED                                  | 76-84 @ 1.70   |
|                          |                          | OPEN                                    | 194-206 @ 1.25 |
|                          | INSTALLED HEIGHT ± 1/32" |   | 1-23/32        |
| DAMPER                   | FREE LENGTH              |   | 1.86           |
|                          | APPROX. # OF COILS       |   | 4              |

### TORQUE SPECIFICATIONS

|                                |             |
|--------------------------------|-------------|
| CAMSHAFT SPROCKET              | 20 LB. FT.  |
| CLUTCH PRESSURE PLATE          | 35 LB. FT.  |
| CONN. ROD CAP                  | 45 LB. FT.  |
| CRANKCASE FRONT COVER          | 80 LB. IN.  |
| CYLINDER HEAD                  | 65 LB. FT.  |
| DISTRIBUTOR CLAMP              | 20 LB. FT.  |
| EXHAUST MANIFOLD               | 20 LB. FT.  |
| FLYWHEEL                       | 60 LB. FT.  |
| FLYWHEEL HOUSING               | 30 LB. FT.  |
| FLYWHEEL HOUSING COVER         | 80 LB. IN.  |
| INTAKE MANIFOLD                | 30 LB. FT.  |
| MAIN BEARING CAP               | 70 LB. FT.  |
| OIL FILTER                     | 25 LB. FT.  |
| OIL FILTER BY-PASS VALVE       | 80 LB. IN.  |
| OIL PAN TO CRANKCASE (5/16-18) | 165 LB. IN. |
| OIL PAN TO CRANKCASE (1/4-20)  | 80 LB. IN.  |
| OIL PUMP                       | 65 LB. FT.  |
| OIL PUMP COVER                 | 80 LB. IN.  |
| ROCKER ARM COVER               | 45 LB. IN.  |
| SPARK PLUG                     | 22 LB. FT.  |
| TEMP. SENDING UNIT             | 20 LB. FT.  |
| TORSIONAL DAMPER               | 60 LB. FT.  |
| WATER OUTLET                   | 25 LB. FT.  |
| WATER PUMP                     | 30 LB. FT.  |



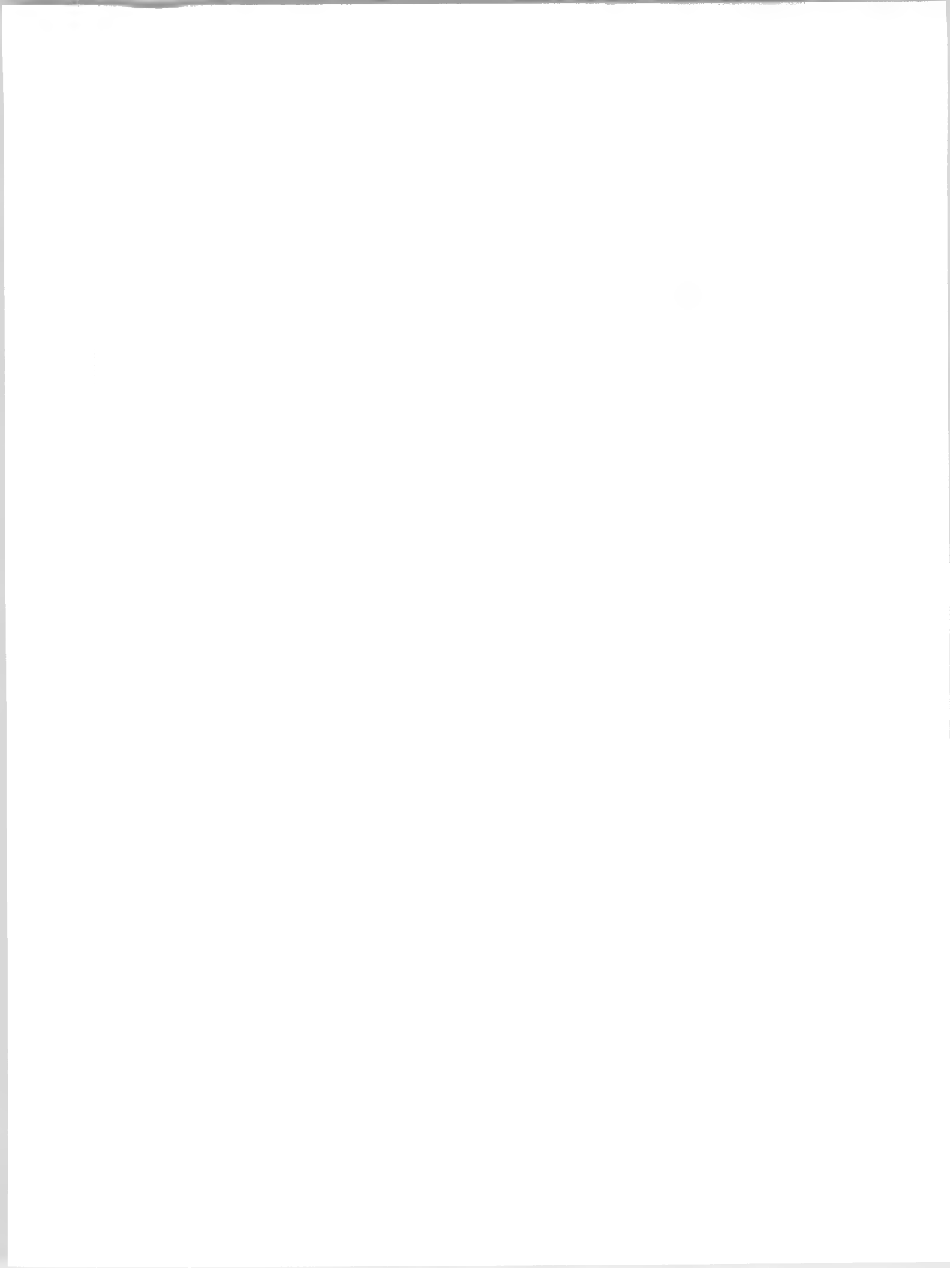

## 7.4 LITER V-8 VIN CODE W (LE8)

### Contents

|                             |    |                                       |    |
|-----------------------------|----|---------------------------------------|----|
| General Description.....    | 1  | Crankcase Front Cover.....            | 17 |
| Engine Lubrication.....     | 4  | Oil Seal (Front Cover).....           | 18 |
| On Vehicle Service.....     | 4  | Camshaft.....                         | 18 |
| Engine Mounts.....          | 9  | Camshaft Bearings.....                | 19 |
| Intake Manifold.....        | 9  | Oil Pan.....                          | 20 |
| Exhaust Manifold.....       | 10 | Oil Pump.....                         | 20 |
| Rocker Arm Cover.....       | 10 | Connecting Rod Bearings.....          | 21 |
| Valve Mechanism.....        | 11 | Main Bearings.....                    | 22 |
| Valve Stem Oil Seal and/or  |    | Oil Seal (Rear Main).....             | 24 |
| Valve Spring.....           | 11 | Connecting Rod Piston Assemblies..... | 25 |
| Valve Lifters.....          | 12 | Cylinder Block.....                   | 28 |
| Cylinder Head Assembly..... | 13 | Oil Filter ByPass Valve.....          | 29 |
| Rocker Arm Studs.....       | 16 | Engine Assembly.....                  | 29 |
| Valve Guide Bores.....      | 16 | Crankshaft.....                       | 30 |
| Valve Seats.....            | 16 | Sprocket or Gear Replacement.....     | 30 |
| Valves.....                 | 16 | Specifications.....                   | 31 |
| Torsional Damper.....       | 16 |                                       |    |

## GENERAL DESCRIPTION (FIG. 6A5-1 & 6A5-2)

### CYLINDER BLOCK

The cylinder block is made of cast iron and has 8 cylinders arranged in a "V" shape with 4 cylinders in each bank. Five main bearings support the crankshaft which is retained by bearing caps that are machined with the block for proper alignment and clearances. Cylinders are completely encircled by coolant jackets.

### CYLINDER HEAD

The cast iron cylinder heads have individual intake and exhaust ports for each cylinder. Valve guides are integral, and rocker arms are retained on individual threaded studs.

### CRANKSHAFT AND BEARINGS

The crankshaft is cast nodular iron, and is supported by five main bearings. Number five bearing is the end thrust bearing.

All main bearings are lubricated from oil holes that connect to the main oil gallery. This runs along the left side of the cylinder case, just above the oil pan rail. Two additional galleries supply oil to the valve lifters.

A torsional damper on the forward end of the crankshaft dampens any engine torsional vibrations.

### CAMSHAFT AND DRIVE

The cast iron camshaft is supported by five bearings and is chain driven. An iron crankshaft gear drives the timing

chain which in turn drives the camshaft through an aluminum and nylon sprocket.

Cam lobes are ground, hardened and tapered with the high side toward the rear. This, coupled with a spherical face on the lifter, causes the valve lifters to rotate and thrusts the cam rearward in the case.

Camshaft bearings are lubricated through oil holes which intersect the main oil gallery. The main oil gallery is rifle drilled down the left side of the cylinder case.

### PISTONS AND CONNECTING RODS

The pistons are made of cast aluminum alloy using two compression rings and one oil control ring. Pins are Chromium steel and have a floating fit in the pistons. They are retained in the connecting rods by a press fit.

Connecting rods are made of forged steel. Full pressure lubrication is directed to the connecting rods by drilled oil passages from the adjacent main bearing journal. Oil holes at the connecting rod journals are located so that oil is supplied to give maximum lubrication just prior to full bearing load.

### VALVE TRAIN

A very simple ball pivot-type train is used. Motion is transmitted from the camshaft through the hydraulic lifter and push rod to the rocker arm. The rocker arm pivots on its ball and transmits the camshaft motion to the valve. The rocker-arm ball is retained by a nut.

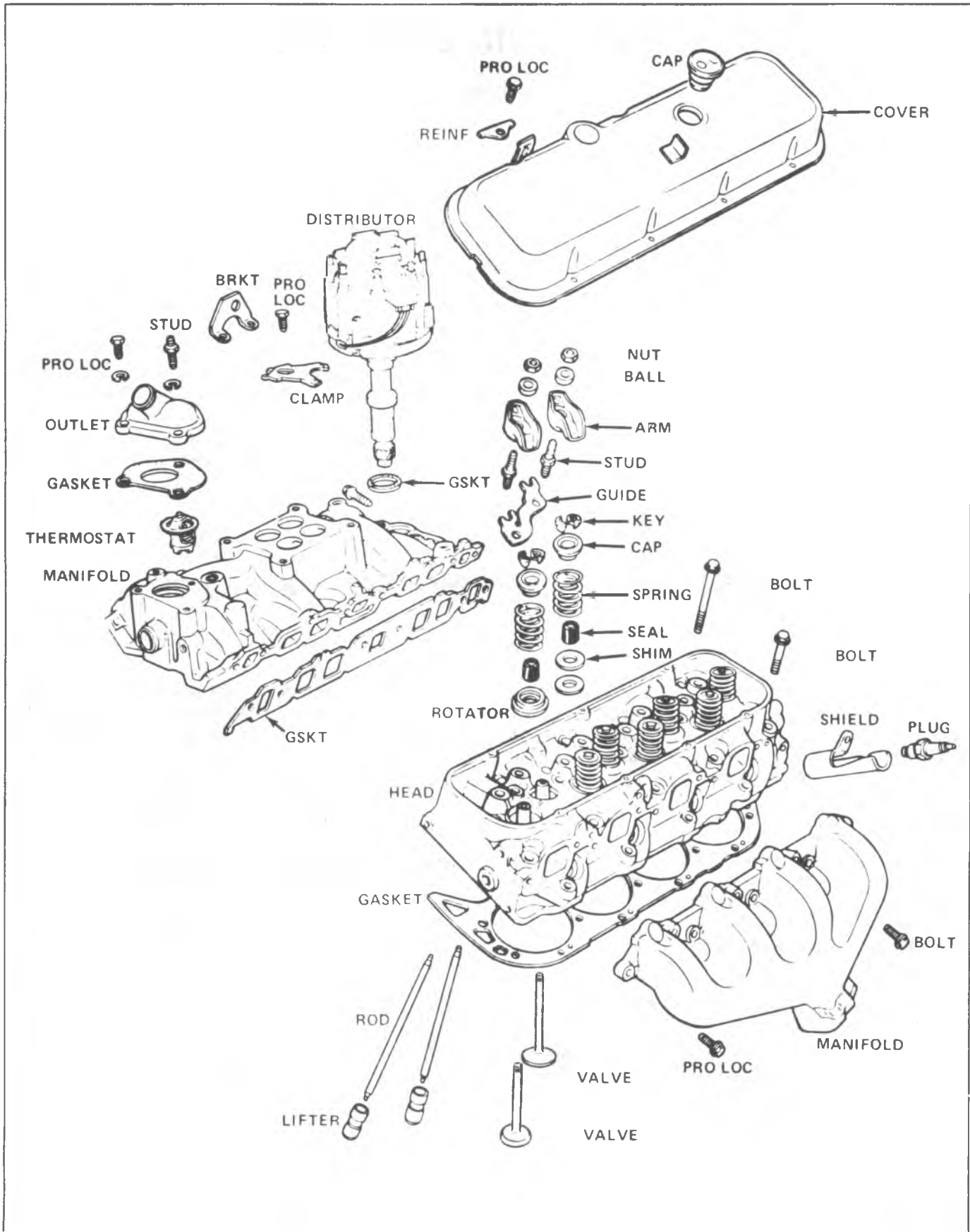

Fig. 6A5-1--Engine Upper End

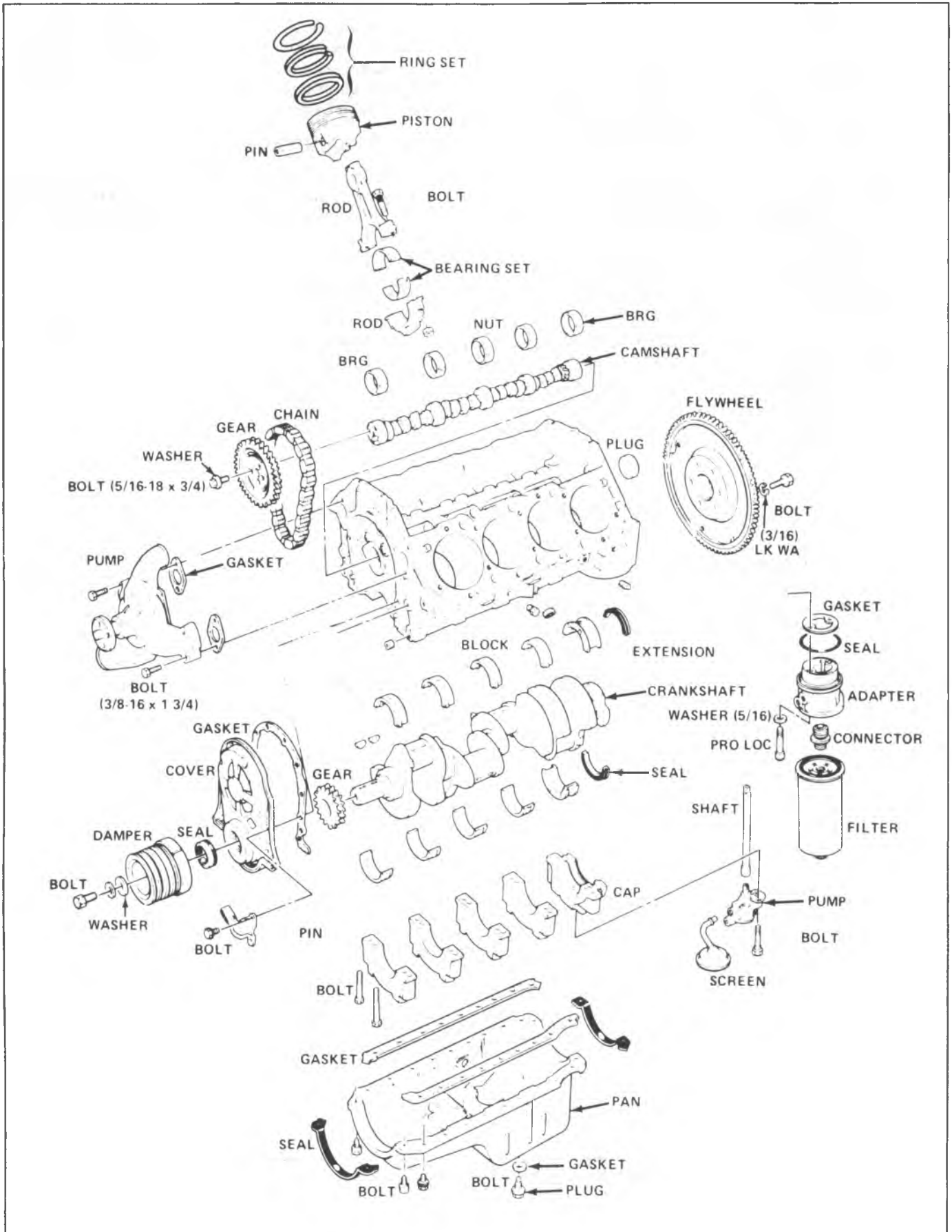

Fig. 6A5-2--Engine Lower End

## HYDRAULIC VALVE LIFTERS

Hydraulic Valve Lifters are used to keep all parts of the valve train in constant contact.

The hydraulic lifter assembly consists of: the lifter body, which rides in the cylinder block boss, a plunger, a push rod seat, a metering valve, a plunger spring, a check ball and spring, a check ball retainer and a push rod seat retainer.

When the lifter is riding on the low point of the cam, the plunger spring keeps the plunger and push rod seat in contact with the push rod.

When the lifter body begins to ride up the cam lobe, the check ball cuts off the transfer of oil from the reservoir below the plunger. The plunger and lifter body then rise as a unit, pushing up the push rod and opening the valve.

As the lifter body rides down the other side of the cam, the plunger follows with it until the valve closes. The lifter body continues to follow the cam to its low point, but the plunger spring keeps the plunger in contact with the push rod. The ball check valve will then move off its seat and the lifter reservoir will remain full.

## INTAKE MANIFOLD

The intake manifold is of cast iron double level design for efficient fuel distribution. The carburetor pad is centrally located with a passage running underneath the pad (E.F.E.) through which exhaust gases are forced to promote faster fuel vaporization when the engine is cold.

## EXHAUST MANIFOLDS

Two cast iron exhaust manifolds are used to direct exhaust gases from the combustion chambers to the exhaust system. The right hand side manifold receives a heat shield that is used to route heated air to the air cleaner for better fuel vaporization.

## COMBUSTION CHAMBERS

Combustion Chambers are cast to insure uniform shape for all cylinders. Spark plugs are located between the intake and exhaust valves.

The contoured wedge shape of the combustion chamber minimizes the possibility of detonation, facilitates breathing, and provides swirling turbulence for smooth, complete combustion.

## ENGINE LUBRICATION

Full pressure lubrication through a full flow oil filter, is furnished by a gear-type oil pump. The distributor, driven by a helical gear on the camshaft, drives the oil pump. The main oil gallery feeds oil, through drilled passages, to the

camshaft and crankshaft to lubricate the bearings. The valve lifter oil gallery feeds the valve lifters which, through hollow push rods, feed the individually mounted rocker arms (fig. 6A5-3).

## ON VEHICLE SERVICE

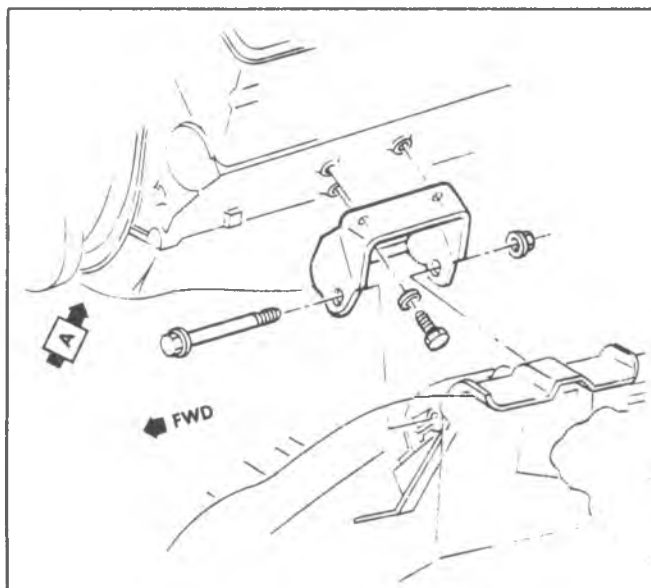

Fig. 6A5-4--"P" Series Engine Mount Bracket

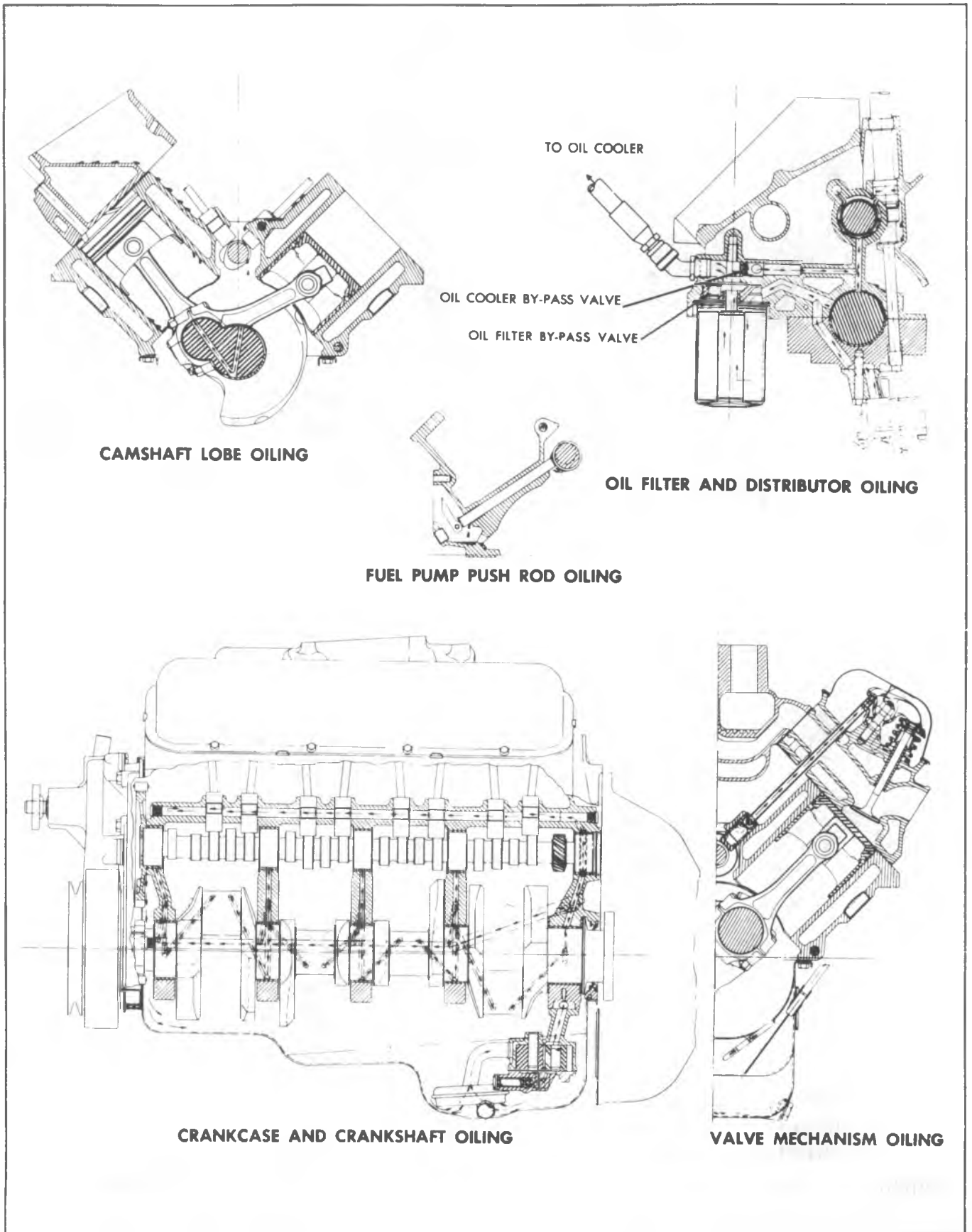
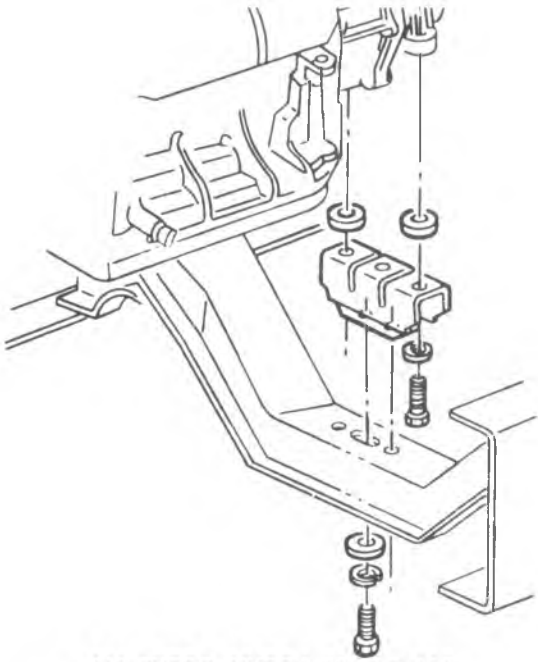
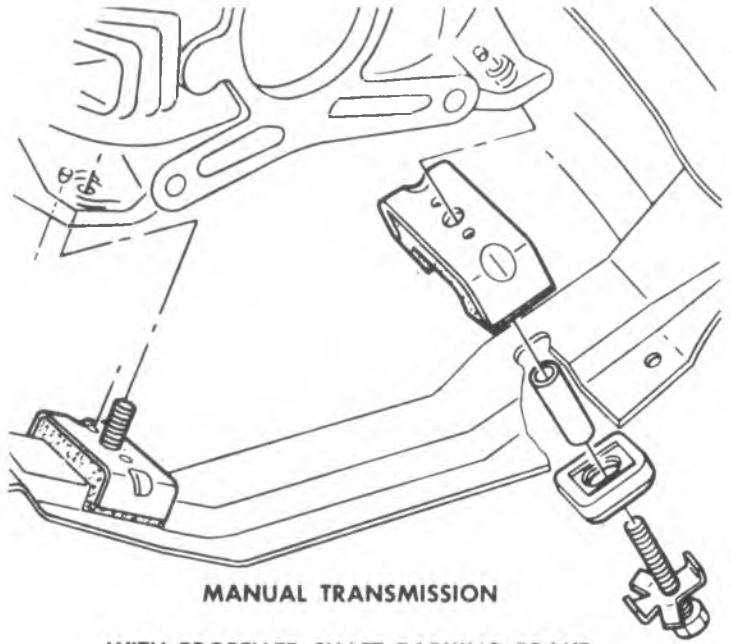

Fig. 6A5-3--"Mark IV" Engine Lubrication



ALL TURBO HYDRA-MATIC 400  
(EXCEPT MOBILE HOME CHASSIS)

WITHOUT PROPELLER SHAFT PARKING BRAKE



MANUAL TRANSMISSION

WITH PROPELLER SHAFT PARKING BRAKE

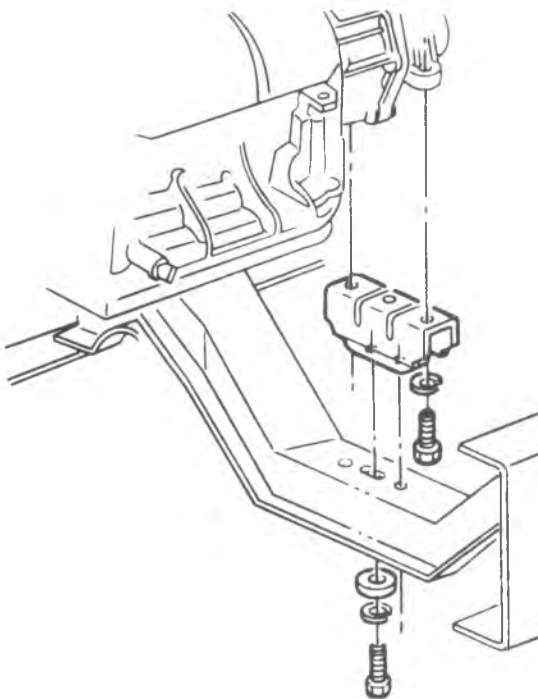

ALL MANUAL TRANSMISSION  
ALL TURBO HYDRA-MATIC 350  
ALL MOBILE HOME CHASSIS

WITHOUT PROPELLER SHAFT PARKING BRAKE

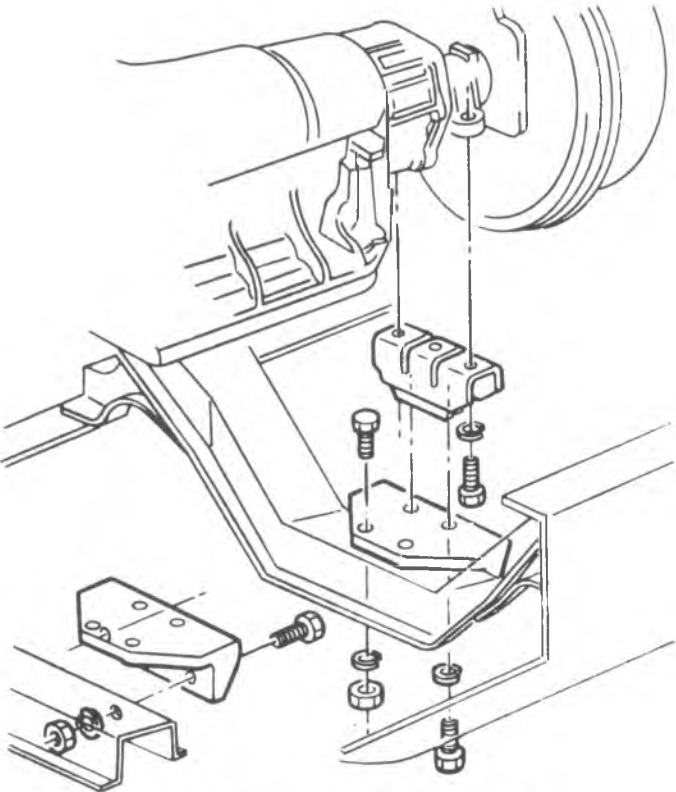

AUTOMATIC TRANSMISSION

WITH PROPELLER SHAFT PARKING BRAKE

Fig. 6A5-5--"P" Series Engine Rear Mount

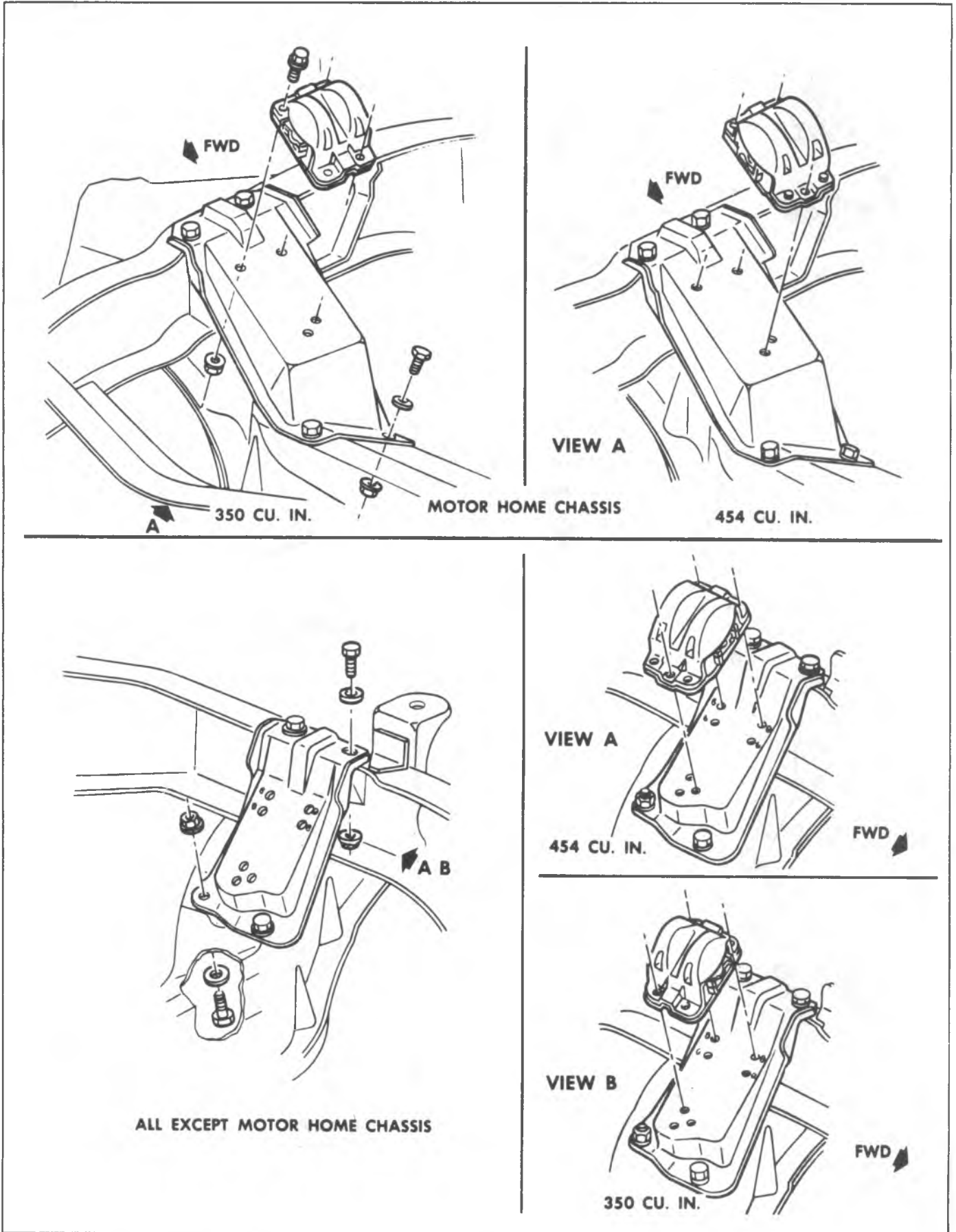

Fig. 6A5-6--"P" Series Engine Front Mount



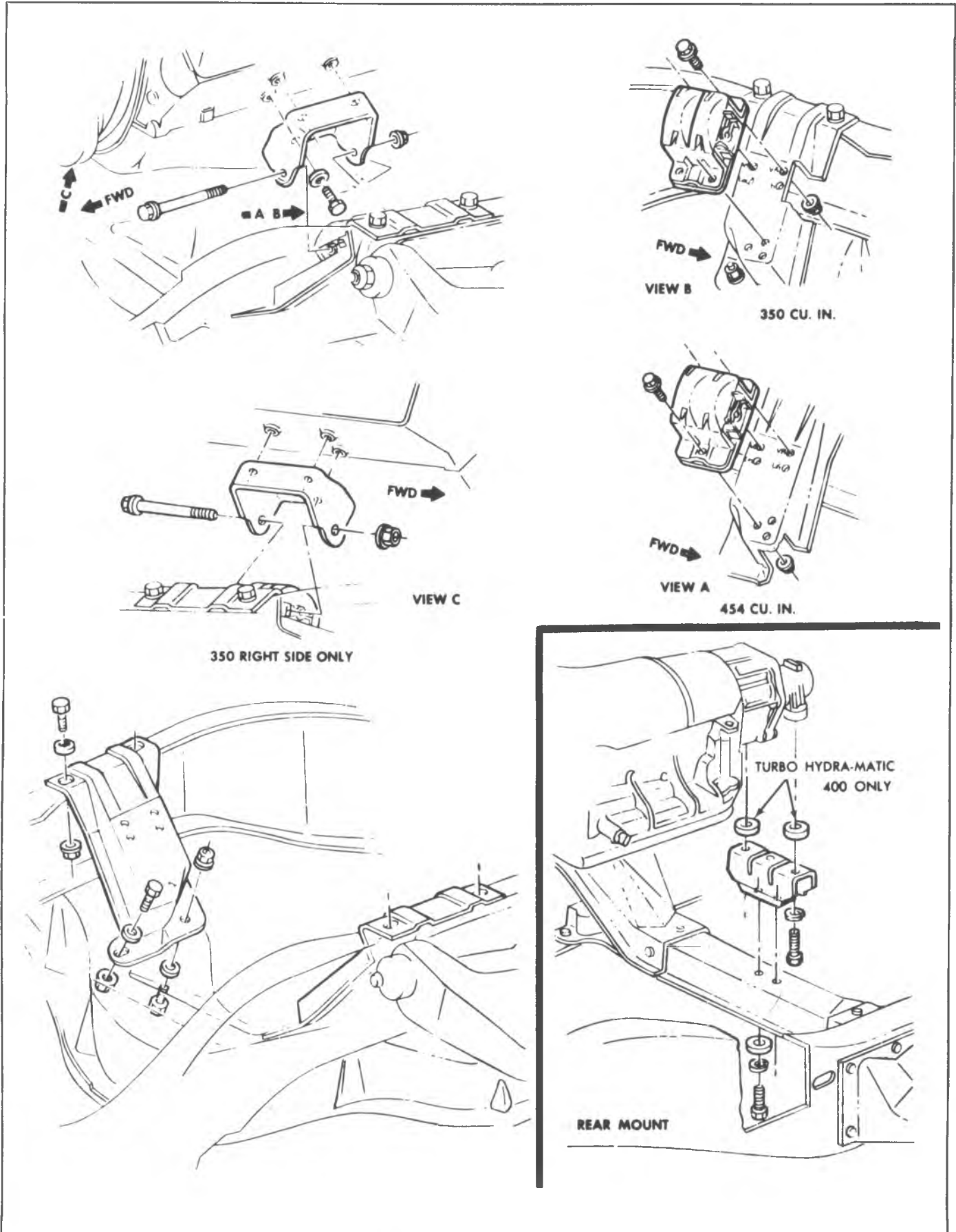

Fig. 6A5-7--"C" Series Engine Mounts

## ENGINE MOUNTS

Engine mounts (fig. 6A5-4 - 6A5-7) are the non-adjustable type and seldom require service. Broken or deteriorated mounts should be replaced immediately, because of the added strain placed on other mounts and drive line components.

### Checking Engine Mounts

#### Front Mount

Raise the engine to remove weight from the mounts and to place a slight tension in the rubber. Observe both mounts while raising engine. If an engine mount exhibits:

- a. Hard rubber surface covered with heat check cracks;
- b. Rubber separated from a metal plate of the mount; or
- c. Rubber split through center

Replace the mount. If there is relative movement between a metal plate of the mount and its attaching points, lower the engine on the mounts and tighten the screws or nuts attaching the mount to the engine, frame, or bracket.

#### Rear Mount

Raise the vehicle on a hoist. Push up and pull down on the transmission tailshaft while observing the transmission mount. If the rubber separates from the metal plate of the mount or if the tailshaft moves up but not down (mount bottomed out) replace the mount. If there is relative movement between a metal plate of the mount and its attaching point, tighten the screws or nuts attaching the mount to the transmission or crossmember.

### Front Mount Replacement

1. Remove mount retaining bolt from below frame mounting bracket.
2. Raise front of engine and remove mount-to-engine bolts and remove mount. Raise engine only enough for sufficient clearance. Check for interference between rear of engine and cowl panel which could cause distributor damage.
3. Replace mount to engine and lower engine into place.
4. Install retaining bolt and torque all bolts to specifications.

### Rear Mount Replacement

1. Support engine weight to relieve rear mounts.
2. Remove crossmember-to-mount bolts.
3. On "P" Series with manual transmission and propeller shaft parking brake, remove mount attaching bolts from frame outrigger and clutch housing and remove rear mounting cushions.
4. Remove mount-to-transmission bolts, then remove mount.
5. On "P" Series with manual transmission and propeller shaft parking brake, install new mounting cushions and bolts.
6. Install new mount on transmission.
7. While lowering transmission, align and start crossmember-to-mount bolts.
8. Torque bolts to specifications then bend lock tabs to bolt head as applicable.

## INTAKE MANIFOLD

### Removal

1. Drain radiator and remove air cleaner.
2. Disconnect:
  - Battery negative cable at battery.
  - Radiator upper hose and heater hose at manifold.
  - Water pump by-pass at water pump.
  - Accelerator linkage at carburetor.
  - Fuel line at carburetor.
  - Crankcase ventilation lines.
  - Spark advance hose at distributor.
3. Remove distributor cap and mark rotor position with chalk, then remove distributor.
4. Remove (as required) air compressor and bracket, accelerator return spring and bracket, and accelerator bellcrank.
5. Remove generator upper mounting bracket.
  - With A/C, remove rear compressor bracket.
6. Remove manifold attaching bolts, then remove manifold and carburetor as an assembly. Discard gaskets and seals.
7. If manifold is to be replaced, transfer:
  - Carburetor and carburetor attaching bolts.
  - Temperature sending unit.
  - Thermostat with housing (use new gasket).
  - Heater hose and water pump by-pass adapters.
  - TVS switch (if applicable).
  - Vacuum fitting(s).

### Installation

1. Clean gasket and seal surfaces on manifold, block, and cylinder heads with degreaser.
2. Install gaskets on cylinder heads and new end seals on block.
3. Install manifold and torque bolts to specifications in the sequence outlined in fig. 6A5-8.
4. Install (if removed) air compressor and bracket, accelerator bellcrank.

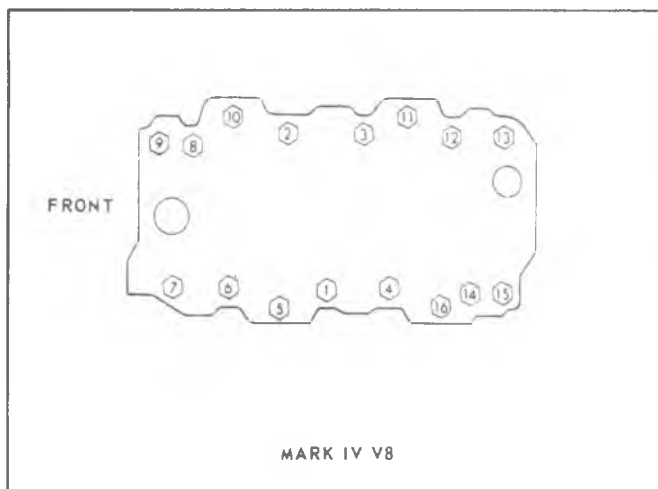

Fig. 6A5-8--Intake Manifold Torque Sequence

5. Install distributor, positioning rotor at chalk mark, then install distributor cap.
6. Connect:
  - Spark advance hose at distributor.
  - Crankcase ventilation lines.
  - Fuel line at carburetor.
  - Accelerator linkage at carburetor.
  - Water pump by-pass at water pump.
  - Battery negative cable at battery.
7. Install air cleaner.
8. Fill with coolant, start engine, adjust ignition timing and carburetor idle speed and check for leaks.

## EXHAUST MANIFOLD

### Removal

1. Remove carburetor air cleaner and heat stove pipe.
2. Remove spark plugs.
3. Disconnect exhaust pipe from manifold and hang exhaust pipe from frame with wire.
4. Remove end bolts then remove center bolts and remove manifold.

### Installation

If installing a new right side manifold, the carburetor heat stove must be transferred from the old unit (fig. 6A5-9).

1. Clean mating surfaces on manifold and head, then install manifold in position and install bolts.
2. Torque manifold bolts to specifications.
3. Connect exhaust pipe to manifold.
4. Install spark plugs and torque to 22 lb. ft. (30 N·m).
5. Install carburetor heat stove pipe.
6. Start engine and check for leaks.

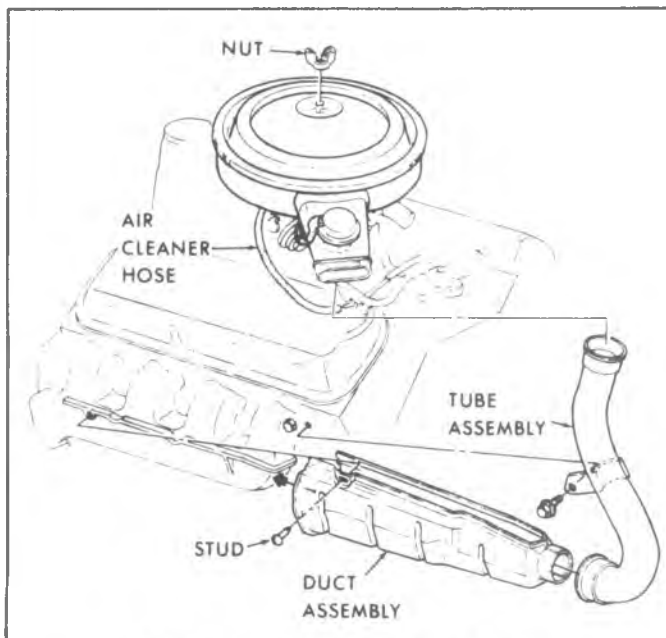

Fig. 6A5-9--Carburetor Heat Stove Assembly

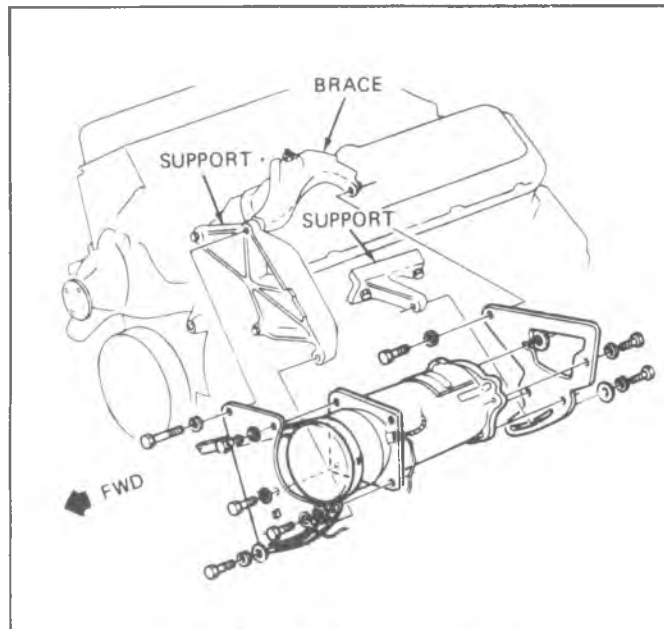

Fig. 6A5-10--A/C Compressor Mounting

## ROCKER ARM COVER

### Removal

1. Remove air cleaner.
2. Disconnect crankcase ventilation hoses at rocker arm covers.
3. Disconnect electrical wiring harness from rocker arm clips.
4. Remove carburetor heat stove pipe from right exhaust manifold.
5. If the vehicle is equipped with air conditioning, remove the A/C compressor upper brace (fig. 6A5-10).
6. Remove rocker arm cover to head attaching bolts and remove rocker arm cover.

**NOTICE:** If cover adheres to cylinder head, shear off by bumping end of rocker arm cover with a rubber mallet. If cover will not come loose, **CAREFULLY** pry until loose. **DO NOT DISTORT SEALING FLANGE.**

### Installation

1. Clean sealing surface on cylinder head and rocker arm cover with degreaser. Using a 3/16" (5mm) bead of RTV, #1052366 or equivalent, place rocker arm cover on the head, install retaining bolts and torque to specification. Loose RTV sealant, or pieces causing installation interference, must be removed from both cylinder head and cover seal surfaces prior to applying new sealant.
  - When going around the attaching bolt holes, always flow the RTV on the inboard side of the holes.
2. On A/C equipped vehicles, install the A/C compressor upper brace. Adjust pulley belt to specification.
3. Install carburetor heat stove pipe.
4. Connect electrical wiring harness at clips on rocker arm cover.
5. Connect crankcase ventilation hoses.
6. Install air cleaner, start engine and check for leaks.

## VALVE MECHANISM

### Removal

1. Remove rocker arm covers as previously outlined.
2. Remove rocker arm nuts, rocker arm balls, rocker arms and push rods. Place rocker arms, rocker arm balls and push rods in a rack so they may be reinstalled in the same locations.

### Installation and Adjustment

Whenever new rocker arms and/or rocker arm balls are being installed, coat bearing surfaces of rocker arms and rocker arm balls with "Molykote" or its equivalent.

1. Install push rods. Be sure push rods seat in lifter socket.
2. Install rocker arms, rocker arm balls and rocker arm nuts. Tighten rocker arm nuts until all lash is eliminated.
3. Adjust valves when lifter is on base circle of camshaft lobe as follows:
  - a. Crank engine until mark on torsional damper lines up with center or "O" mark on the timing tab fastened to the crankcase front cover and the engine is in the #1 firing position. This may be determined by placing fingers on the #1 valve as the mark on the damper comes near the "O" mark on the crankcase front cover. If the valves are not moving, the engine is in the #1 firing position. If the valves move as the mark comes up to the timing tab, the engine is in #6 firing position and should be turned over one more time to reach the #1 position.
  - b. With the engine in the #1 firing position as determined above, the following valves may be adjusted.
    - Exhaust--1, 3, 4, 8
    - Intake--1, 2, 5, 7
  - c. Back out adjusting nut until lash is felt at the push rod then turn in adjusting nut until all lash is

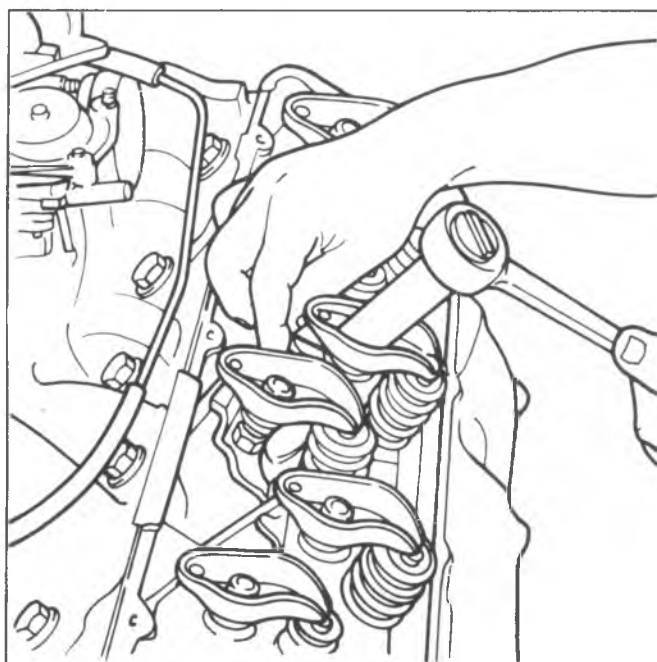

Fig. 6A5-11--Valve Adjustment

removed. This can be determined by rotating push rod while turning adjusting nut (fig. 6A5-11). When play has been removed, turn adjusting nut in one full additional turn (to center lifter plunger).

- d. Crank the engine one revolution until the pointer "o" mark and torsional damper mark are again in alignment. This is #6 firing position. With the engine in this position the following valves may be adjusted.
    - Exhaust--2, 5, 6, 7
    - Intake--3, 4, 6, 8
4. Install rocker arm covers as previously outlined.
  5. Start engine and adjust carburetor idle speed.

## VALVE STEM OIL SEAL and/or VALVE SPRING

### Removal

1. Remove rocker arm cover as previously outlined.
2. Remove spark plug, rocker arm and push rod on the cylinder(s) to be serviced.
3. Install air line adapter Tool J-23590 to spark plug port and apply compressed air to hold the valves in place.
4. Using Tool J-5892 to compress the valve spring, remove the valve locks, valve cap and valve spring and damper (fig. 6A5-12).
5. Remove the valve stem oil seal.

### Installation

1. Install new valve stem oil seal (coated with oil) in position over valve guide (fig. 6A5-13). Seal installation instructions are supplied with each service kit. Install seal following procedures outlined on the supplied instruction sheet.

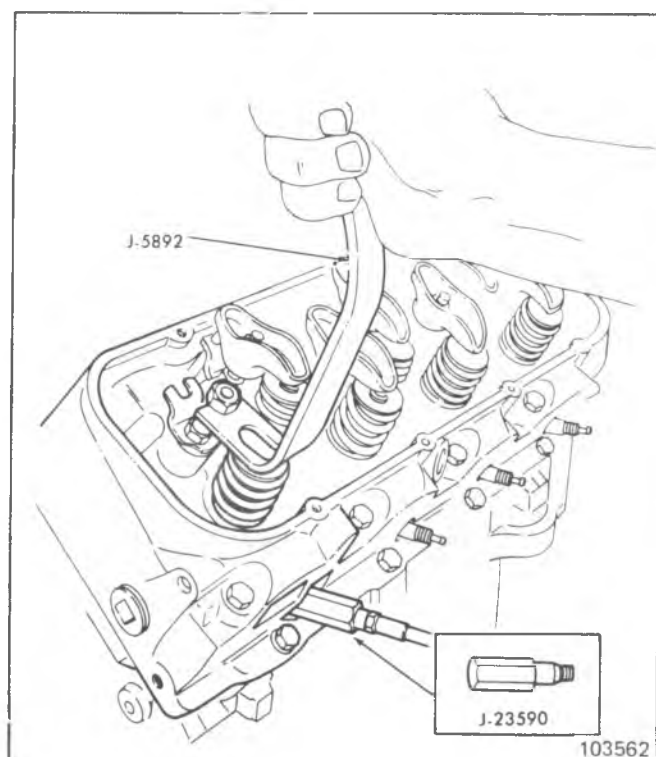

Fig. 6A5-12--Compressing Valve Spring

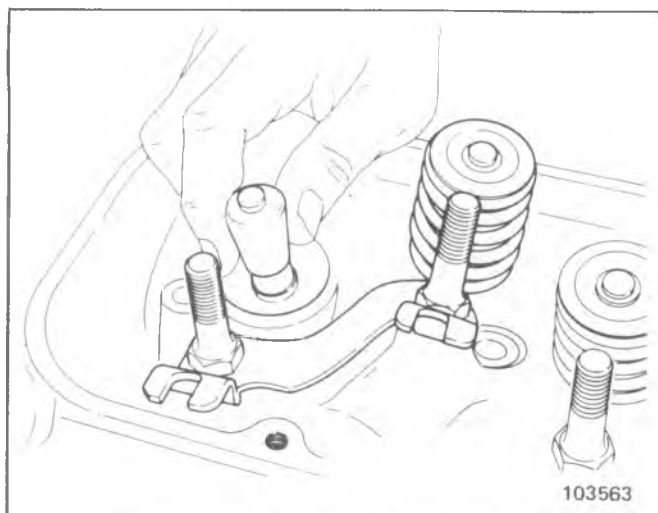

Fig. 6A5-13--Installing Valve Stem Oil Seal

2. Set the valve spring and damper and valve cap in place.
3. Compress the spring with Tool J-5892 and install the valve locks then release the compressor tool, making sure the locks seat properly in the groove of the valve stem. Grease may be used to hold the locks in place while releasing the compressor tool.
4. Install spark plug, and torque to 22 lb. ft. (30 N·m).
5. Install and adjust valve mechanism as previously outlined.

## VALVE LIFTERS

Hydraulic valve lifters very seldom require attention. The lifters are extremely simple in design, readjustments are not necessary, and servicing of the lifters requires only that care and cleanliness be exercised in the handling of parts.

### Removal

1. Remove intake manifold as previously outlined.
2. Remove valve mechanism as previously outlined.
3. Remove valve lifters. Place valve lifters in a rack so that they may be reinstalled in the same location.

### Installation

1. Coat foot of valve lifters with "Molykote" or its equivalent and install valve lifters. Make sure lifter foot is convex.
2. Install intake manifold as previously outlined.
3. Install and adjust valve mechanism as outlined.

### Disassembly

1. Hold the plunger down with a push rod, and using the blade of a small screw driver, remove the push rod seat retainer.
2. Remove the push rod seat and metering valve (fig. 6A5-14).
3. Remove the plunger, ball check valve assembly and the plunger spring.
4. Remove the ball check valve and spring by prying the ball retainer loose from the plunger with the blade of a small screw driver (fig. 6A5-15).

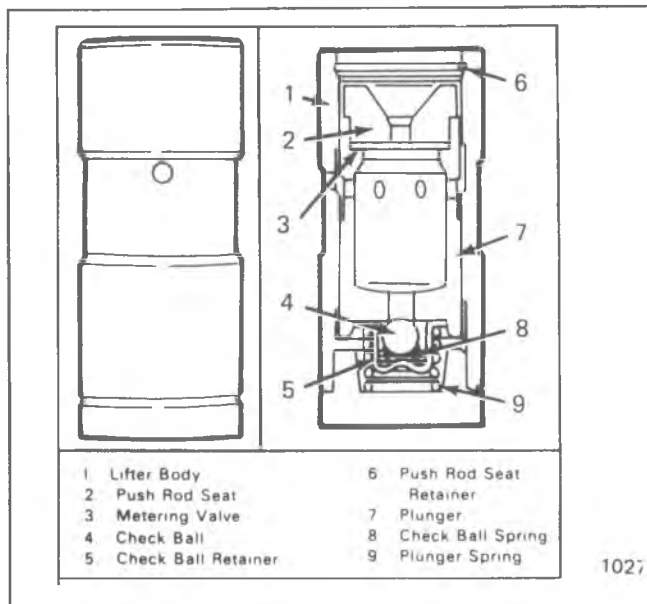

Fig. 6A5-14--Hydraulic Valve Lifter



Fig. 6A5-15--Removing Ball Check Valve

### Cleaning and Inspection

Thoroughly clean all parts in cleaning solvent, and inspect them carefully. If any parts are damaged or worn, the entire lifter assembly should be replaced. If the lifter body wall is scuffed or worn, inspect the cylinder block lifter bore. If the bottom of the lifter is scuffed or worn, inspect the camshaft lobe. If the push rod seat is scuffed or worn, inspect the push rod. An additive containing EP lube, such as EOS, should always be added to crankcase oil for run-in when any new camshaft or lifters are installed. All damaged or worn lifters should be replaced.

- For proper lifter rotation during engine operation, lifter foot must be convex.

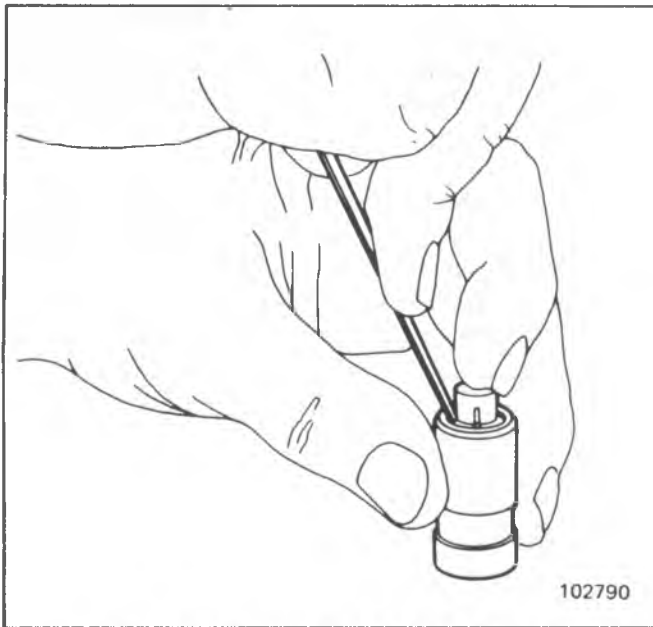

Fig. 6A5-16--Installing Ball Check Valve

**Assembly**

1. Place the check ball on small hole in bottom of the plunger.
2. Insert check ball spring on seat in ball retainer and place retainer over ball so that spring rests on the ball. Carefully press the retainer into position in plunger with the blade of a small screw driver (fig. 6A5-16).
3. Place the plunger spring over the ball retainer and slide the lifter body over the spring and plunger, being careful to line up the oil feed holes in the lifter body and plunger.
4. Fill the assembly with SAE 10 oil, then insert the end of a 1/8" drift pin into the plunger and press down solid. Do not attempt to force or pump the plunger. At this point, oil holes in the lifter body and plunger assembly will be aligned (fig. 6A5-17).

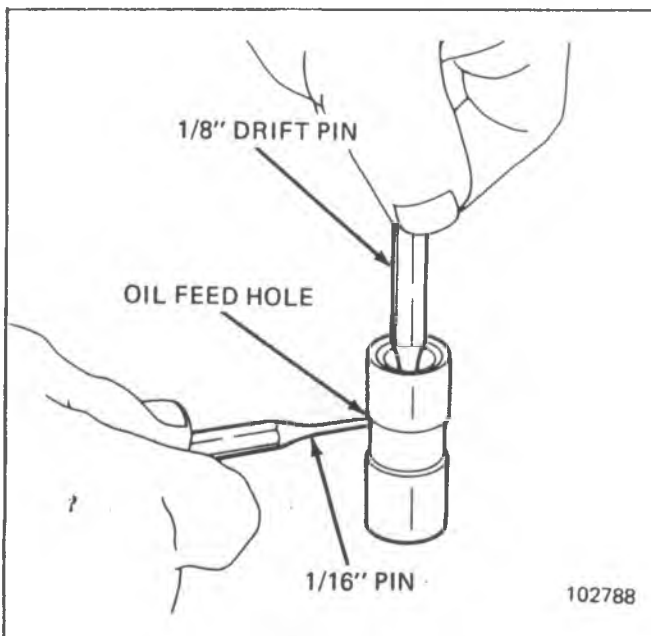

Fig. 6A5-17--Assembling Hydraulic Lifter

5. Insert a 1/16" drift pin through both oil holes to hold the plunger down against the lifter spring tension (fig. 6A5-17).
6. Remove the 1/8" drift pin, refill assembly with SAE 10 oil.
7. Install the metering valve and push rod seat (fig. 6A5-14).
8. Install the push rod seat retainer, press down on the push rod seat and remove the 1/16" drift pin from the oil holes. The lifter is now completely assembled, filled with oil and ready for installation. Before installing lifters, coat the bottom of the lifter with "Molykote" or its equivalent.

**CYLINDER HEAD ASSEMBLY**

**Removal**

1. Remove intake manifold as previously outlined.
2. Remove generator lower mounting bolt and lay unit aside.
3. Remove exhaust manifolds as previously outlined.
4. If vehicle is equipped with A/C, remove A/C compressor and forward mounting bracket. Lay unit aside.
5. Remove valve mechanism as previously outlined.
6. Drain cylinder block of coolant.
7. Remove cylinder head bolts, cylinder head and gasket. Place cylinder head on two blocks of wood to prevent damage.

**Disassembly**

1. With cylinder head removed, remove valve rocker arm nuts, balls and rocker arms (if not previously done).
2. Using Tool J-8062, compress the valve springs (fig. 6A5-18) and remove valve keys. Release the compressor tool and remove rotators or spring caps, springs and spring damper, then remove oil seals and valve spring shims.

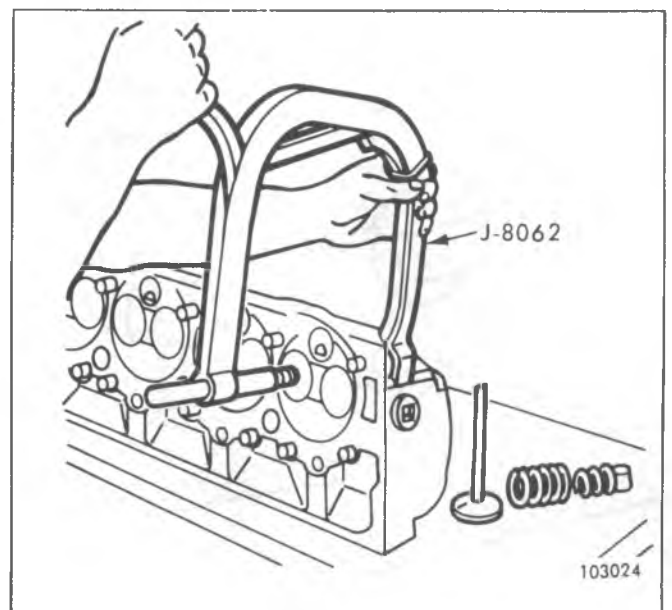

Fig. 6A5-18--Compressing Valve Spring

3. Remove valves from cylinder head and place them in a rack in their proper sequence so that they can be assembled in their original positions.

**Cleaning**

1. Clean all carbon from combustion chambers and valve ports using Tool J-8089 (fig. 6A5-19).
2. Thoroughly clean the valve guides using Tool J-8101 (fig. 6A5-20).
3. Clean all carbon and sludge from push rods, rocker arms and push rod guides.
4. Clean valve stems and heads on a buffing wheel.
5. Clean carbon deposits from head gasket mating surface.

**Inspection**

1. Inspect the cylinder head for cracks in the exhaust ports, combustion chambers, or external cracks to the coolant chamber.
2. Inspect the valves for burned heads, cracked faces or damaged stems.

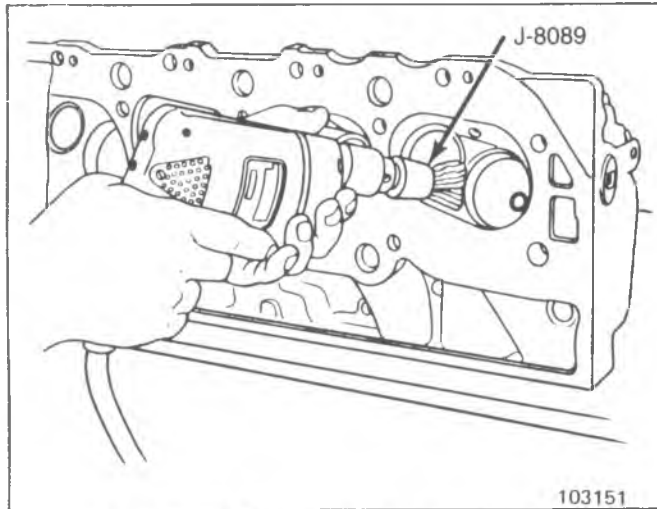

Fig. 6A5-19--Cleaning Combustion Chambers

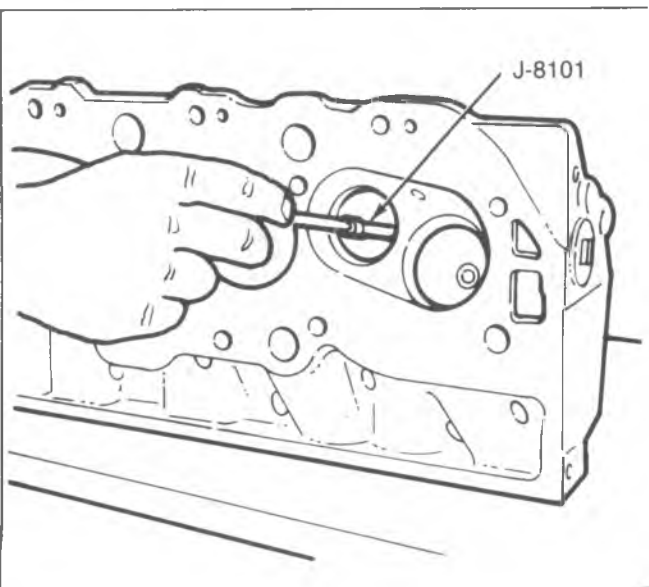

Fig. 6A5-20--Cleaning Valve Guides

**NOTICE:** Excessive valve stem to bore clearance will cause excessive oil consumption and may cause valve breakage. Insufficient clearance will result in noisy and sticky functioning of the valve and disturb engine smoothness.

3. Measure valve stem clearance (fig. 6A5-21) as follows:
  - a. Clamp a dial indicator on one side of the cylinder head rocker arm cover gasket rail.
  - b. Locate the indicator so that movement of the valve stem from side to side (crosswise to the head) will

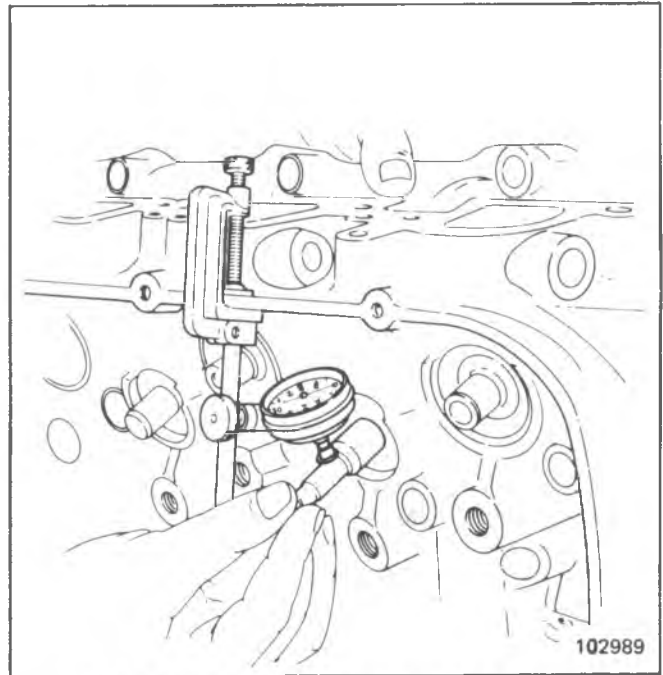

Fig. 6A5-21--Measuring Valve Stem Clearances

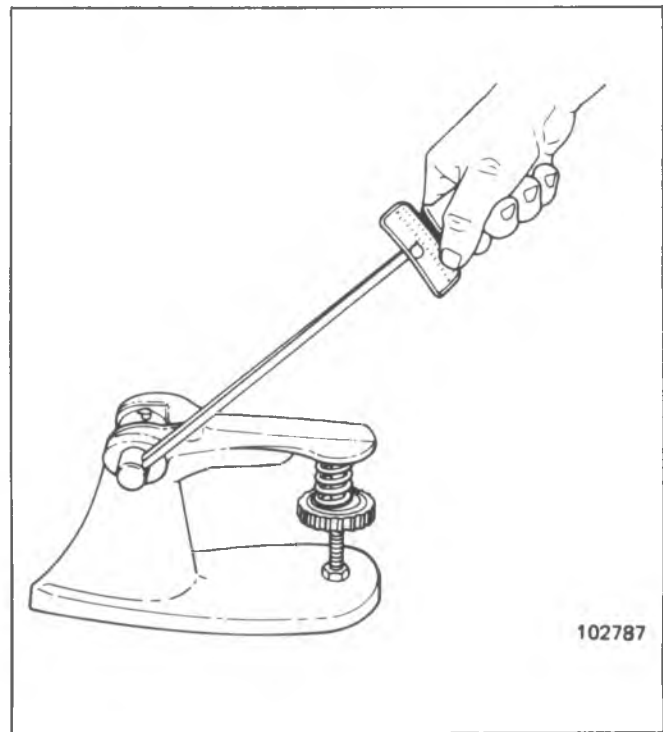

Fig. 6A5-22--Checking Valve Spring Tension



cause a direct movement of the indicator stem. The indicator stem must contact the side of the valve stem just above the valve guide.

- c. Drop the valve head about 1/16" (1.6mm) off the valve seat.
  - d. Move the stem of the valve from side to side using light pressure to obtain a clearance reading. If clearance exceeds specifications, it will be necessary to ream valve guides for oversize valves as outlined.
4. Check valve spring tension with Tool J-8056 spring tester (fig. 6A5-22). Springs should be compressed to the specified height and checked against the specifications chart. Springs should be replaced if not within 10 lbs. (44 N) of the specified load (without dampers).
  5. Inspect rocker arm studs for wear or damage. Inspect push rod guides for wear or damage.

**Assembly**

1. Insert a valve in the proper port.
2. Assemble the valve spring and related parts as follows:
  - a. Install valve spring shim on valve spring seat then install a new valve stem oil seal over valve and valve guide.
  - b. Set the valve spring (with damper); and valve cap in place (fig. 6A5-23).
  - c. Compress the spring with Tool J-8062.
  - d. Install the valve locks and release the compressor tool, making sure the locks seat properly in the groove of the valve stem. Grease may be used to hold the locks in place while releasing the compressor tool.
3. Install the remaining valves.

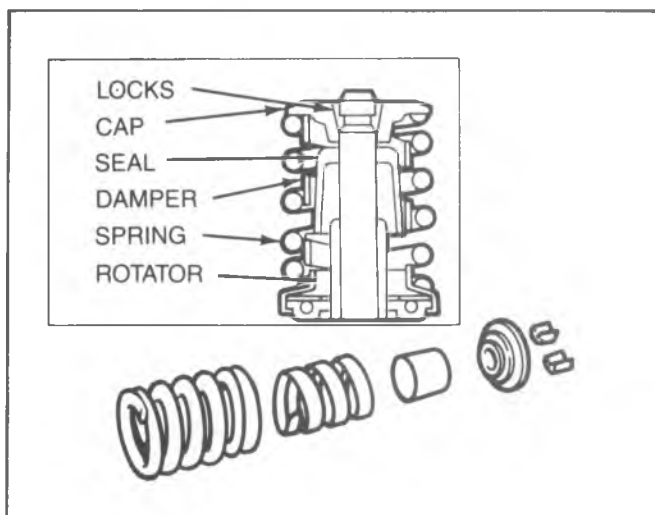

Fig. 6A5-23--Valve Spring Installation

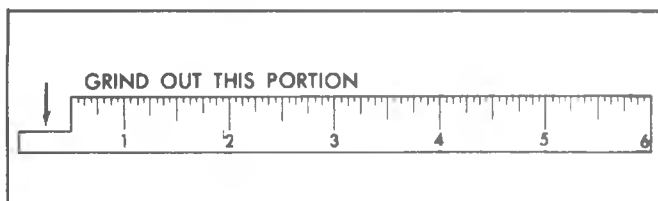

Fig. 6A5-24--Cutaway Scale

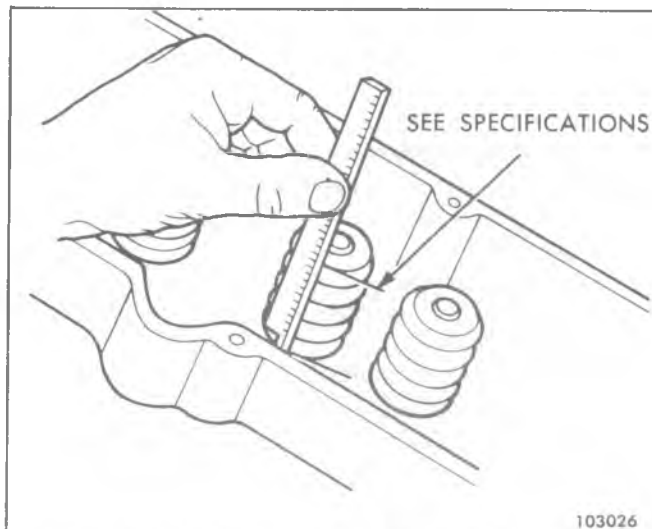

Fig. 6A5-25--Measuring Valve Spring Installed Height

4. Check the installed height of the valve springs, using a narrow thin scale. A cutaway scale will help (fig. 6A5-24). Measure from the top of the shim or the spring seat to the top of the valve spring or valve spring shield (fig. 6A5-25). If this is found to exceed the specified height, install a valve spring seat shim approximately 1/16" (1.6mm) thick. At no time should the spring be shimmed to give an installed height under the minimum specified.

**Installation**

- The gasket surfaces on both the head and the block must be clean of any foreign matter and free of nicks or heavy scratches. Cylinder bolt threads in the block and threads on the cylinder head bolts must be clean as dirt will affect bolt torque.
1. On engines using a STEEL gasket, coat both sides of a new gasket with a good sealer. Spread the sealer thin and even. One method of applying the sealer that will assure the proper coat is with the use of a paint roller. Too much sealer may hold the gasket away from the head or block.

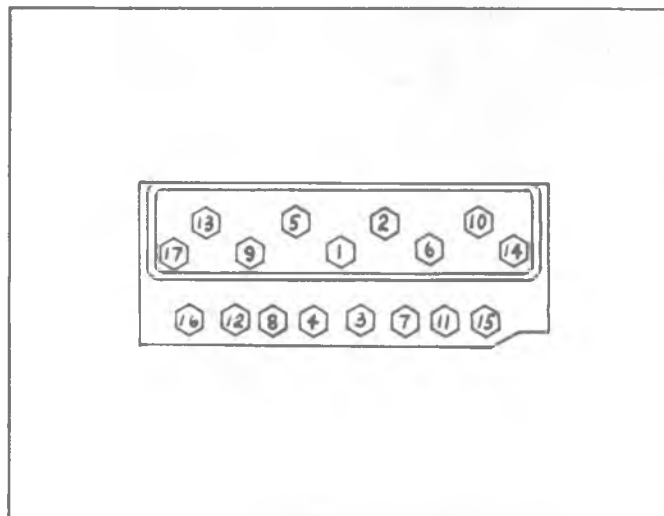

Fig. 6A5-26--Cylinder Head Torque Sequence



- Use no sealer on engines using a composition STEEL ASBESTOS gasket.
2. Place the gasket in position over the dowel pins with the bead up.
  3. Carefully guide the cylinder head into place over the dowel pins and gasket.
  4. Coat threads of cylinder head bolts with sealing compound, #1052080 or equivalent, and install bolts finger tight.
  5. Tighten each cylinder head bolt a little at a time in the sequence shown in figure 6A5-26 until the specified torque is reached.
  6. Install exhaust manifolds as previously outlined.
  7. Install intake manifold as previously outlined.
  8. Install and adjust valve mechanism as previously outlined.

## ROCKER ARM STUDS

### Replacement

The push rod guides are attached to the cylinder head by the rocker arm studs (fig. 6A5-27). Replace where necessary and torque rocker arm studs to specifications.

## VALVE GUIDE BORES

Valves with oversize stems are available (see specifications). To ream the valve guide bores for oversize valves use Tool Set J-7049.

## VALVE SEATS

Reconditioning the valve seats is very important, because the seating of the valves must be perfect for the engine to deliver the power and performance built into it.

Another important factor is the cooling of the valve heads. Good contact between each valve and its seat in the

head is imperative to insure that the heat in the valve head will be properly carried away.

Several different types of equipment are available for reseating valves seats. The recommendations of the manufacturer of the equipment being used should be carefully followed to attain proper results.

Regardless of what type of equipment is used, however, it is essential that valve guide bores be free from carbon or dirt to ensure proper centering of pilot in the guide.

## VALVES

Valves that are pitted can be refaced to the proper angle, insuring correct relation between the head and stem on a valve refacing mechanism. Valve stems which show excessive wear, or valves that are warped excessively should be replaced. When a valve head which is warped excessively is refaced, a knife edge will be ground on part or all of the valve head due to the amount of metal that must be removed to completely reface. Knife edges lead to breakage, burning or pre-ignition due to heat localizing on this knife edge. If the edge of the valve head is less than 1/32" (.80mm) thick after grinding, replace the valve (fig. 6A5-29).

Several different types of equipment are available for refacing valves. The recommendation of the manufacturer of the equipment being used should be carefully followed to attain proper results.

## TORSIONAL DAMPER

### Removal

1. Remove fan belt, fan and pulley.
2. Remove the fan shroud assembly as outlined in Section 6B.
  - If additional operations (such as camshaft removal) are not being performed, the radiator removal will not be necessary.
3. Remove accessory drive pulley then remove damper retaining bolt.
4. Install Tool J-23523 on damper then, turning puller screw, remove damper.

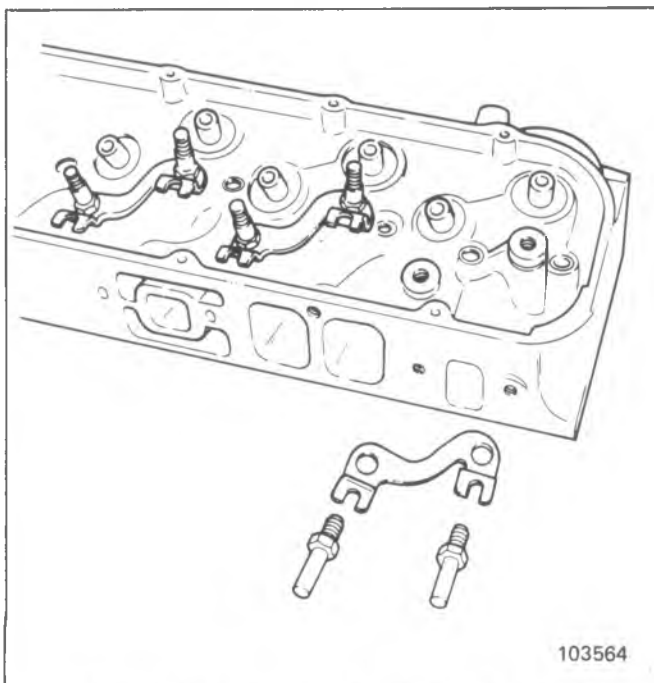

Fig. 6A5-27--Rocker Arm Stud & Push Rod Guide

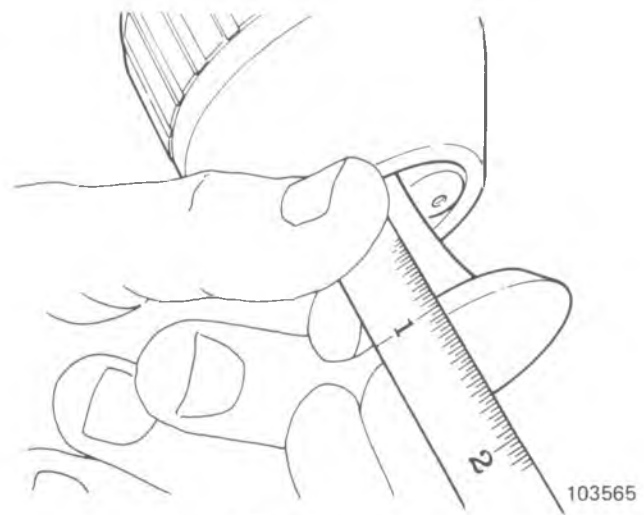

Fig. 6A5-29--Measuring Valve Head

## Installation

**NOTICE:** The inertial weight section of the torsional damper is assembled to the hub with a rubber type material. The installation procedures (with proper tool) must be followed or movement of the inertia weight section on the hub will destroy the tuning of the torsional damper.

1. Coat front cover seal contact area (on damper) with engine oil.
2. Place damper in position over key on crankshaft.
3. Pull damper onto crankshaft as follows:
  - a. Install appropriate threaded end of Tool J-23523 into crankshaft. Install tool in crankshaft so that at least 1/2" (6.5mm) of thread engagement is obtained.
  - b. Install plate, thrust bearing and nut to complete tool installation.
  - c. Pull damper into position as shown in Figure 6A5-30.
  - d. Remove tool from crankshaft then install damper retaining bolt and torque to specifications.
4. Install accessory drive pulley.
5. Install fan shroud as outlined in Section 6B.
6. Install fan and pulley to water pump hub and tighten securely.
7. Install fan belt and adjust to specifications using strand tension gage.
8. Fill cooling system, start engine and check for leaks.

## CRANKCASE FRONT COVER

### Removal

1. Remove torsional damper and water pump as outlined.
2. Remove the two, oil pan-to-front cover attaching screws.
3. Remove the front cover-to-block attaching screws.
4. Pull the cover slightly forward only enough to permit cutting of oil pan front seal.

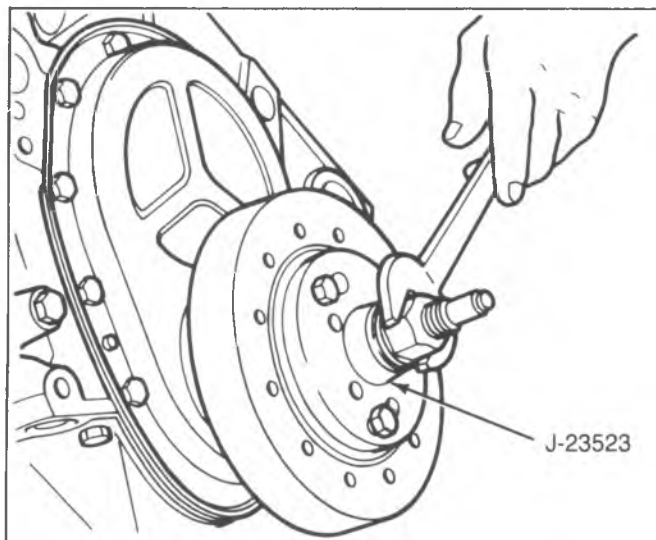

Fig. 6A5-30--Installing Torsional Damper

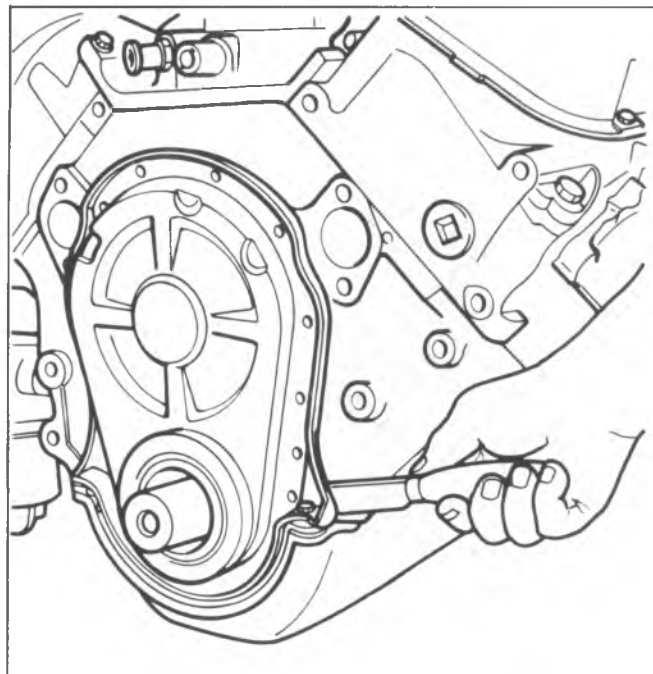

Fig. 6A5-31--Cutting Tabs on Oil Pan Front Seal

5. Using a sharp knife or other suitable cutting tool, cut oil pan front seal flush with cylinder block at both sides of cover (fig. 6A5-31).
6. Remove front cover and attaching portion of oil pan front seal. Remove front cover gasket.

### Installation

1. Clean gasket surface on block and crankcase front cover.
2. Cut tabs from the new oil pan front seal (fig. 6A5-32). Use a sharp instrument to ensure a clean cut.
3. Install seal to front cover, pressing tips into holes provided in cover.
4. Coat the gasket with gasket sealer and place in position on cover.
5. Apply a 1/8" (3mm) bead of RTV sealer, #1052366 or equivalent, to the joint formed at the oil pan and cylinder block (fig. 6A5-33).
6. Position crankcase front cover over crankshaft.
7. Press cover downward against oil pan until cover is aligned and installed over dowel pins on block.

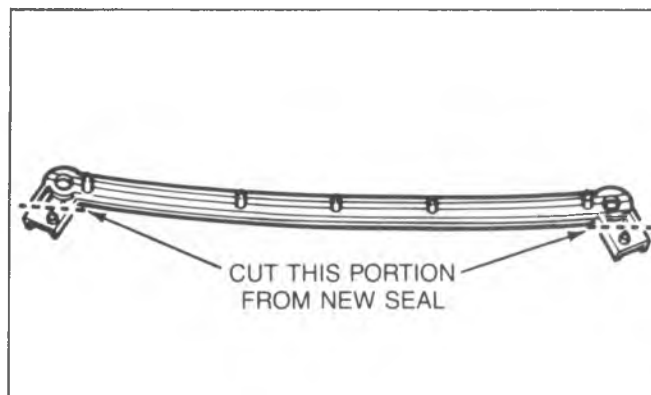

Fig. 6A5-32--Oil Pan Front Seal Modification

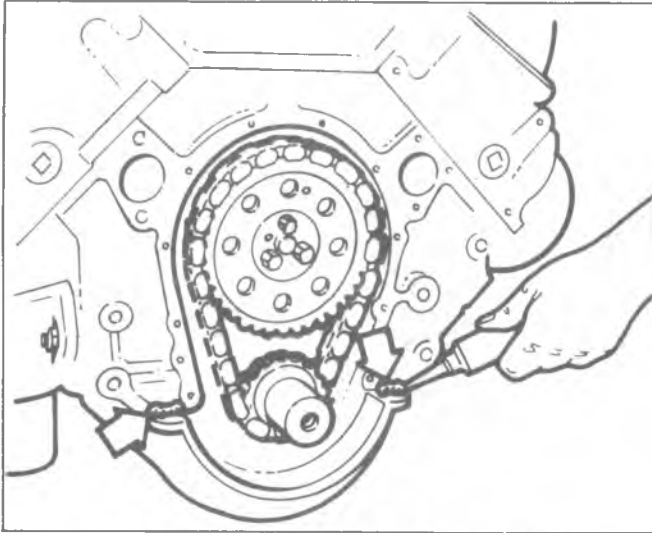

Fig. 6A5-33--Applying Front Cover Sealer

8. Install and partially tighten the two, oil pan-to-front cover attaching screws.
9. Install the front cover-to-block attaching screws.
10. Torque all screws to specifications.
11. Install torsional damper and water pump as previously outlined.

## OIL SEAL (FRONT COVER)

### Replacement

#### With Cover Removed

1. With cover removed, pry oil seal out of cover from the front with a large screw driver.
2. Install new seal so that open end of the seal is toward the inside of cover and drive it into position with Tool J-22102. Support rear of cover at seal area.

#### With Cover Installed

1. With torsional damper removed, pry seal out of cover from the front with a large screw driver. Be careful not to damage the surface on the crankshaft.
2. Install new seal so that open end of seal is toward the inside of cover and drive it into position with Tool J-22102. (fig. 6A5-34).

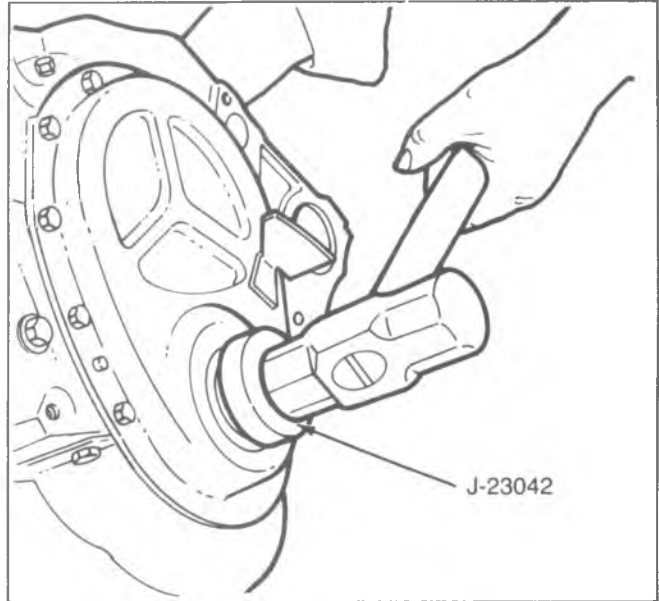

Fig. 6A5-34--Installing Oil Seal



Fig. 6A5-35--Measuring Camshaft Lobe Lift

## CAMSHAFT

### Measuring Lobe Lift

1. Remove the valve mechanism as previously outlined.
2. Position indicator with ball socket adapter (Tool J-8520) on push rod (fig. 6A5-35). Make sure push rod is in the lifter socket.
3. Rotate the crankshaft slowly in the direction of rotation until the lifter is on the heel of the cam lobe. At this point, the push rod will be in its lowest position.
4. Set dial indicator on zero, then rotate the crankshaft slowly, or attach an auxiliary starter switch and "bump" the engine over, until the push rod is fully raised position.
  - Whenever the engine is cranked remotely at the starter, with a special jumper cable or other means,

the distributor primary lead should be disconnected from the distributor (coil).

5. Compare the total lift recorded from the dial indicator with specifications.
6. If camshaft readings for all lobes are within specifications, remove dial indicator assembly.
7. Install and adjust valve mechanism as outlined.

### Removal

1. Remove valve lifters as previously outlined.
2. Remove crankcase front cover as previously outlined.
3. Remove grille.
4. Remove fuel pump push rod as outlined in Section 6C.

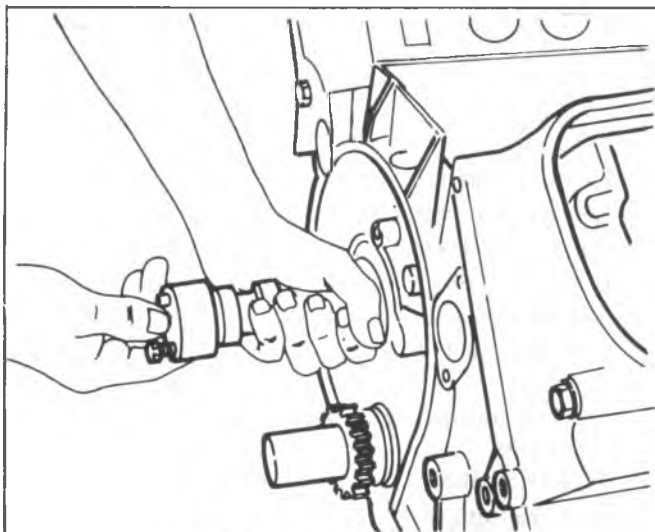

Fig. 6A5-36--Removing Camshaft

5. Complete camshaft removal as follows:

- Sprocket is a light fit on camshaft. If sprocket does not come off easily a light blow on the lower edge of the sprocket (with a plastic mallet) should dislodge the sprocket.

6. Install two 5/16" - 18 x 4" bolts in camshaft bolt holes then remove camshaft (fig. 6A5-36).

**NOTICE:** All camshaft journals are the same diameter and care must be used in removing camshaft to avoid damage to bearings.

#### Inspection

The camshaft bearing journals should be measured with a micrometer for an out-of-round condition. If the journals exceed .001" out-of-round, the camshaft should be replaced.

#### Installation

Whenever a new camshaft is installed coat camshaft lobes with "Molykote" or its equivalent.

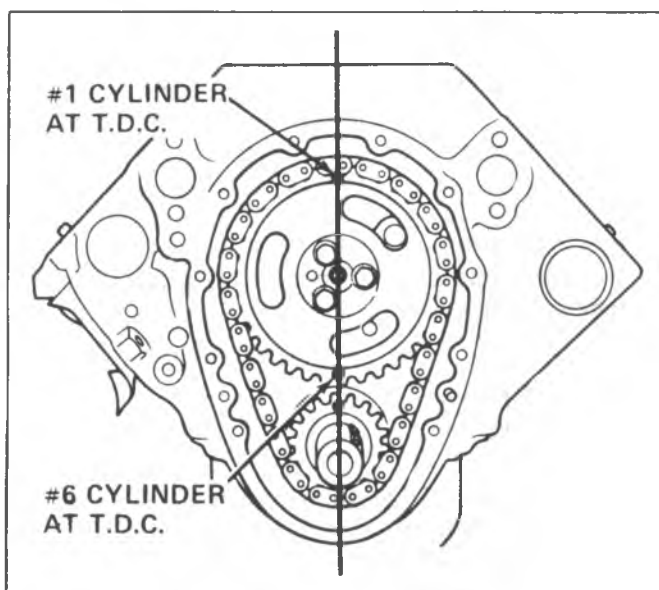

Fig. 6A5-37--Timing Sprocket Alignment Marks

Whenever a new camshaft is installed, replacement of all valve lifters oil filter and engine oil is recommended to insure durability of the camshaft lobes and lifter feet.

1. Lubricate camshaft journals with engine oil and install camshaft.
2. Install timing chain on camshaft sprocket. Hold the sprocket vertically with the chain hanging down and align marks on camshaft and crankshaft sprockets. (Refer to fig. 6A5-37).
3. Align dowel in camshaft with dowel hole in camshaft sprocket then install sprocket on camshaft.
4. Draw the camshaft sprocket onto camshaft using the mounting bolts. Torque to specifications.
5. Lubricate timing chain with engine oil.
6. Install fuel pump push rod as outlined in Section 6C.
7. Install grille.
8. Install crankcase front cover as previously outlined.
9. Install valve lifters as previously outlined.

## CAMSHAFT BEARINGS

### Removal

Camshaft bearings can be replaced while engine is disassembled for overhaul or without complete disassembly of the engine. To replace bearings without complete disassembly remove the camshaft and crankshaft leaving cylinder heads attached and pistons in place. Before removing crankshaft, tape threads of connecting rod bolts to prevent damage to crankshaft. Fasten connecting rods against sides of engine so they will not be in the way while replacing camshaft bearings.

1. With camshaft and crankshaft removed, drive camshaft rear plug from cylinder block.
2. Using Tool J-6098 with nut and thrust washer installed to end of threads, index pilot in camshaft front bearing and install puller screw through pilot.
3. Install remover and installer tool with shoulder toward bearing, making sure a sufficient amount of threads are engaged.

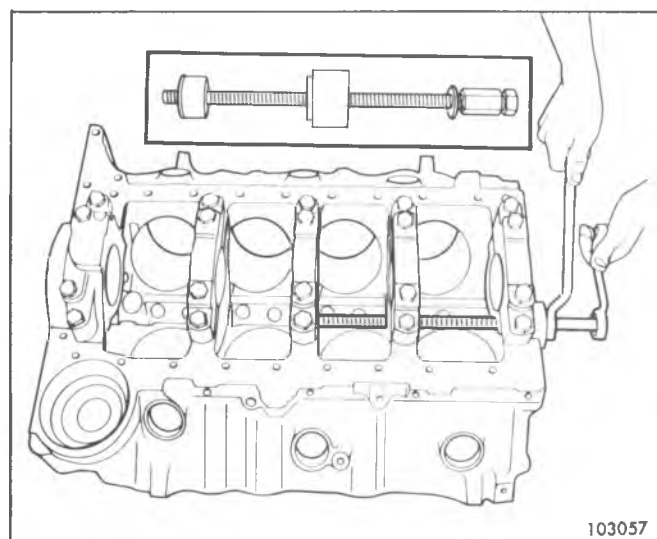

Fig. 6A5-38--Removing Camshaft Bearings

4. Using two wrenches, hold puller screw while turning nut. When bearing has been pulled from bore, remove remover and installer tool and bearing from puller screw (fig. 6A5-38).
5. Remove remaining bearings (except front and rear) in the same manner. It will be necessary to index pilot in camshaft rear bearing to remove the rear intermediate bearing.
6. Assemble remover and installer tool on driver handle and remove camshaft front and rear bearings by driving towards center of cylinder block (fig. 6A5-39).

### Installation

The camshaft front and rear bearings should be installed first. These bearings will act as guides for the pilot and center the remaining bearings being pulled into place.

1. Assemble remover and installer tool on driver handle and install camshaft front and rear bearings by driving towards center of cylinder block (fig. 6A5-39).
2. Using Tool Set J-6098 with nut then thrust washer installed to end of threads, index pilot in camshaft front bearing and install puller screw through pilot.
3. Index camshaft bearing in bore (with oil hole aligned as outlined below), then install remover and installer tool on puller screw with shoulder toward bearing.
  - Number one through number four cam bearing oil hole must be aligned with oil holes in cam bearing bore.
  - The number five bearing bore is annulus, and cam bearing must be positioned at or near the 6 o'clock position.
4. Using two wrenches, hold puller screw while turning nut. After bearing has been pulled into bore, remove the remover and installer tool from puller screw, and check alignment of oil hole in camshaft bearing.
5. Install remaining bearings in the same manner. It will be necessary to index pilot in the camshaft rear bearing to install the rear intermediate bearing.

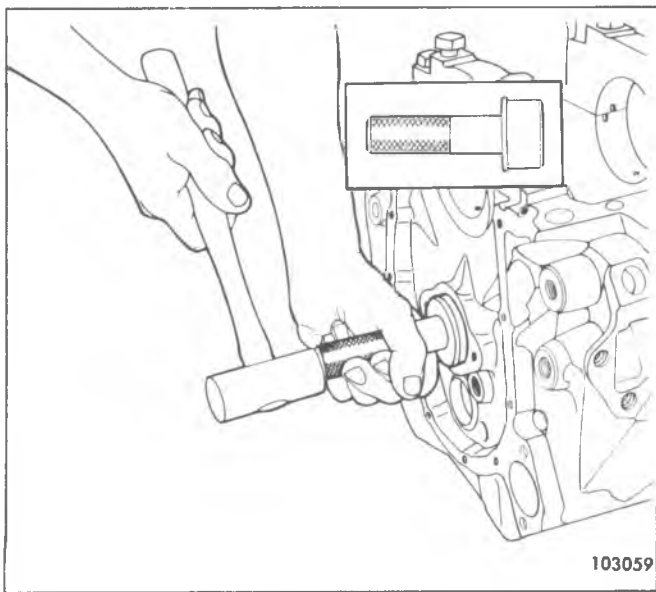

Fig. 6A5-39--Replacing Camshaft Front Bearing

## OIL PAN

### Removal

1. Disconnect battery negative cable.
2. Loosen fan shroud.
3. Remove air cleaner.
4. Remove distributor cap.
5. Raise vehicle and drain oil pan.
  - If equipped with manual transmission, remove starter.
6. Remove torque converter cover or clutch cover as applicable.
7. Remove oil filter.
8. On gage equipped vehicles, remove oil pressure line from side of block.
 

**NOTICE:** Removal of pressure line is important to prevent crushing of line when raising engine.
9. Remove mount "through" bolts and raise engine.
10. Remove oil pan bolts and drop pan.

### Installation

If installing new oil pan, transfer dipstick tube from old unit.

1. With clean sealing surfaces on pan and block, place oil pan on block and install oil pan bolts. Torque to 135 lb. in. (15N·m).
2. Lower engine on mounts and install mount through bolts. Torque to 75 lb. ft. (100 N·m).
3. Install oil pressure line, if applicable, and install oil filter.
4. Install torque converter cover or clutch cover, as applicable.
  - If equipped with manual transmission, install starter.
5. Lower vehicle.
6. Install distributor cap and tighten fan shroud.
7. Fill crankcase with oil; see owners manual.
8. Install air cleaner and connect battery negative cable.
9. Start engine and check for leaks.

## OIL PUMP

### Removal

1. Remove oil pan as previously outlined.
2. Remove pump to rear main bearing cap bolt and remove pump and extension shaft.

### Disassembly (Figure 6A5-40)

1. Remove the pump cover attaching screws and the pump cover.
2. Mark gear teeth so they may be reassembled with the same teeth indexing. Remove the idler gear and the drive gear and shaft from the pump body.
3. Remove the pressure regulator valve retaining pin, pressure regulator valve and related parts.

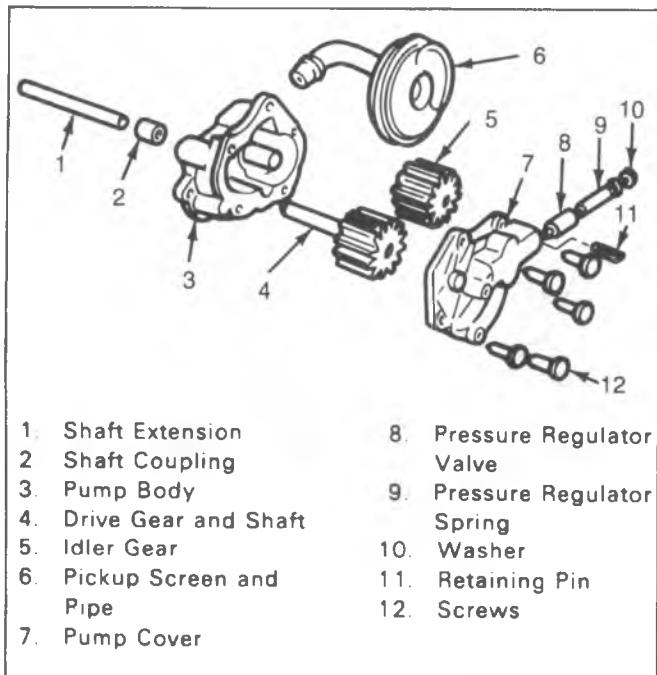

Fig. 6A5-40--Oil Pump

4. If the pickup screen and pipe assembly need replacing, the entire pump must be replaced. The screen and pipe assembly is welded to the pump body.

**Cleaning and Inspection**

1. Wash all parts in cleaning solvent and dry with compressed air.
2. Inspect the pump body and cover for cracks or excessive wear.
3. Inspect pump gears for damage or excessive wear.
  - The pump gears and body are not serviced separately. If the pump gears or body are damaged or worn, replacement of the entire oil pump assembly is necessary.
4. Check the drive gear shaft for looseness in the pump body.
5. Inspect inside of pump cover for wear that would permit oil to leak past the ends of the gears.
6. Inspect the pickup screen and pipe assembly for damage to screen and pipe.
7. Check the pressure regulator valve for fit.

**Assembly (Figures 6A5-40)**

1. Install the pressure regulator valve and related parts.
2. Install the drive gear and shaft in the pump body.
3. Install the idler gear in the pump body with the smooth side of gear towards pump cover opening.
4. Install gasket and the pump cover and torque attaching screws to specifications.
5. Turn drive shaft by hand to check for smooth operation.

**Installation**

1. Assemble pump and extension shaft to rear main bearing cap, aligning slot on top end of extension shaft with drive tang on lower end of distributor drive shaft.
2. Install pump to rear bearing cap bolt and torque to specifications.

3. Install oil pan previously outlined.

**CONNECTING ROD BEARINGS**

Connecting rod bearings are of the precision insert type and do not utilize shims for adjustment. **DO NOT FILE RODS OR ROD CAPS.** If clearances are found to be excessive a new bearing will be required. Service bearings are available in standard size and .001" and .002" undersize for use with new and used standard size crankshafts, and in .010" and .020" undersize for use with reconditioned crankshafts.

**Inspection and Replacement**

1. With oil pan and oil pump removed, remove the connecting rod cap and bearing. Before removal of connecting rod cap, mark the side of the rod and cap with the cylinder number to assure matched reassembly of rod and cap.
2. Inspect the bearing for evidence of wear or damage. (Bearings showing the above should not be installed.)
3. Wipe both upper and lower bearing shells and crankpin clean of oil.
4. Measure the crankpin for out-of-round or taper with a micrometer. If not within specifications replace or recondition the crankshaft. If within specifications and a new bearing is to be installed, measure the maximum diameter of the crankpin to determine new bearing size required.
5. If within specifications measure new or used bearing clearances with Plastigage or its equivalent. If a bearing is being fitted to an out-of-round crankpin, be sure to fit to the maximum diameter of the crankpin. If the bearing is fitted to the minimum diameter and the crankpin is out-of-round .001" interference between the bearing and crankpin will result in rapid bearing failure.

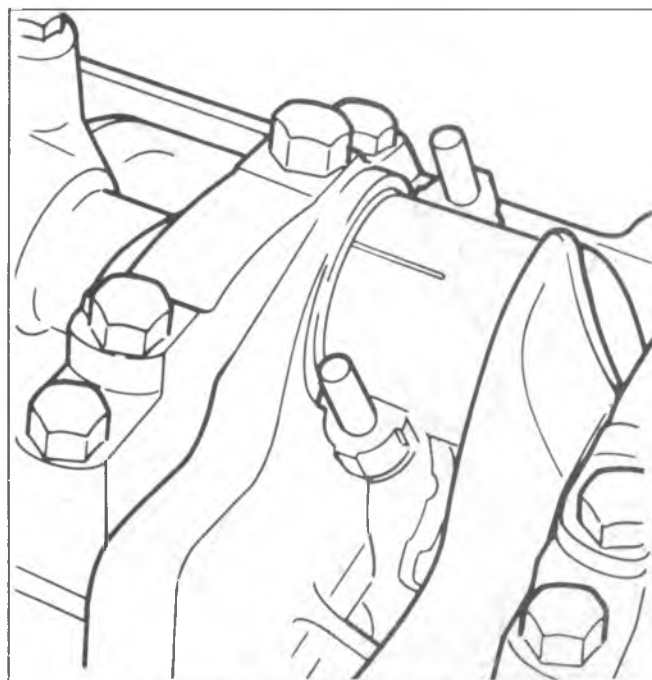

Fig. 6A5-41--Gaging Plastic On Crankpin

- a. Place a piece of gaging plastic, the length of the bearing (parallel to the crankshaft), on the crankpin or bearing surface (fig. 6A5-41). Plastic gage should be positioned in the middle of upper or lower bearing shell. (Bearings are eccentric and false readings could occur if placed elsewhere).
  - b. Install the bearing in the connecting rod and cap.
  - c. Install the bearing cap and evenly torque nuts to specifications. Do not turn the crankshaft with the gaging plastic installed.
  - d. Remove the bearing cap and using the scale on the gaging plastic envelope, measure the gaging plastic width at the widest point (fig. 6A5-42).
6. If the clearance exceeds specifications, select a new, correct size, bearing and remeasure the clearance. Be sure to check what size bearing is being removed in order to determine proper replacement size bearing. If clearance cannot be brought to within specifications, the crankpin will have to be ground undersize. If the crankpin is already at maximum undersize, replace crankshaft.
  7. Coat the bearing surface with oil, install the rod cap and torque nuts to specifications.
  8. When all connecting rod bearings have been installed tap each rod lightly (parallel to the crankpin) to make sure they have clearance.
  9. Measure all connecting rod side clearances (see specifications) between connecting rod caps (fig. 6A5-43).

## MAIN BEARINGS

Main bearings are of the precision insert type and do not utilize shims for adjustment. If clearances are found to be excessive, a new bearing, both upper and lower halves, will be required. Service bearings are available in standard size and .001", .002", .009", .010" and .020" undersize.

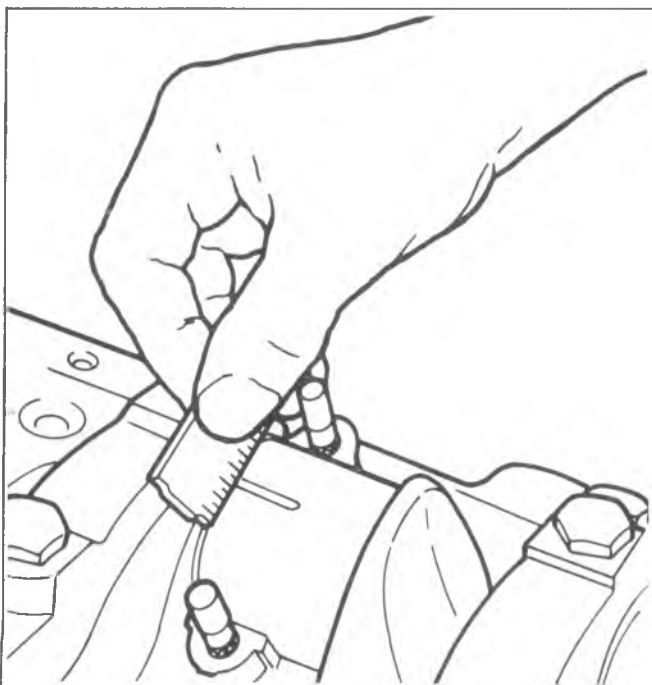

Fig. 6A5-42--Measuring Gaging Plastic

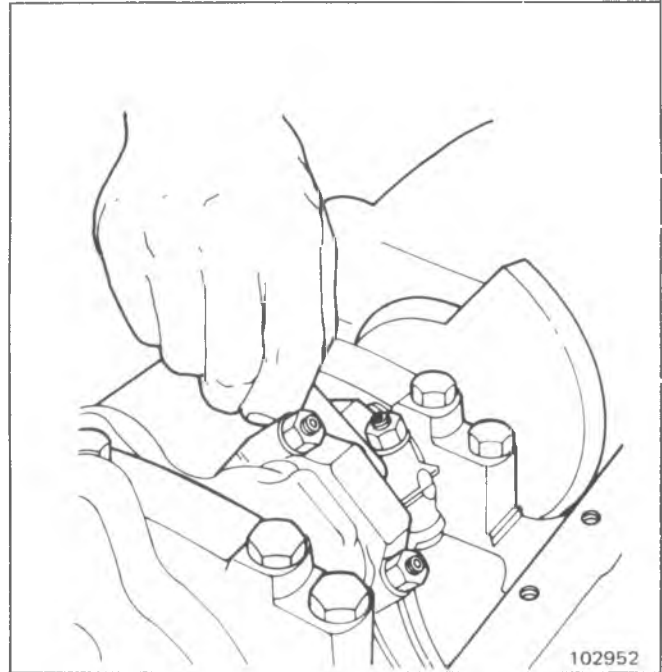

Fig. 6A5-43--Measuring Connecting Rod Side Clearance

Selective fitting of both rod and main bearing inserts is necessary in production in order to obtain close tolerances. For this reason you may find one half of a standard insert with one half of a .001" undersize insert which will decrease the clearance .0005" from using a full standard bearing.

## Inspection

In general, the lower half of the bearing (except #1 bearing) shows a greater wear and the most distress from fatigue. If upon inspection the lower half is suitable for use, it can be assumed that the upper half is also satisfactory. If the lower half shows evidence of wear or damage, both upper and lower halves should be replaced. Never replace one half without replacing the other half.

## Checking Clearance

To obtain the most accurate results with "Plastigage", (or its equivalent) a wax-like plastic material which will compress evenly between the bearing and journal surfaces without damaging either surface, certain precautions should be observed.

If the engine is out of the vehicle and upside down, the crankshaft will rest on the upper bearings and the total clearance can be measured between the lower bearing and journal. If the engine is to remain in the vehicle, the crankshaft must be supported upward to remove the clearance from the upper bearing. The total clearance can then be measured between the lower bearing and journal.

To assure the proper seating of the crankshaft, all bearing cap bolts should be at their specified torque. In addition, preparatory to checking fit of bearings, the surface of the crankshaft journal and bearing should be wiped clean of oil.

1. With the oil pan and oil pump removed, and starting with the rear main bearing, remove bearing cap and wipe oil from journal and bearing cap.



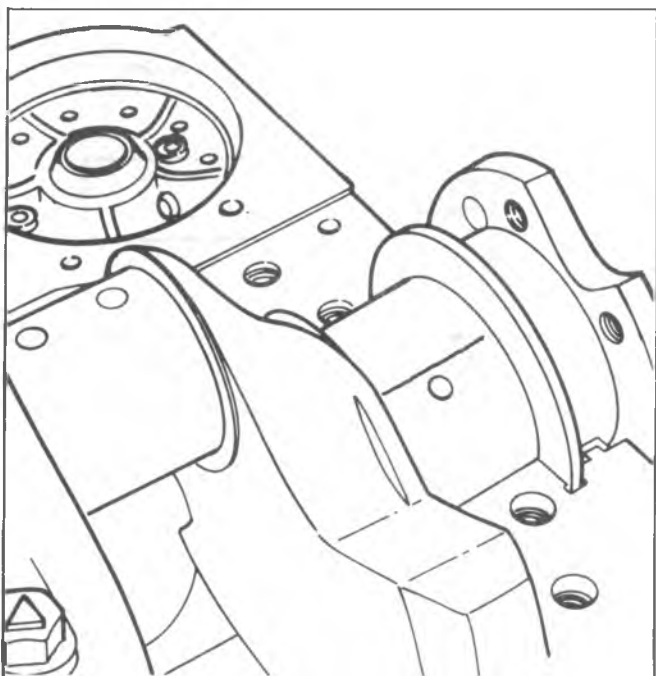

Fig. 6A5-44--Gaging Plastic on Journal

2. Place a piece of gaging plastic the full width of the bearing (parallel to the crankshaft) on the journal (fig. 6A5-44). Do not rotate the crankshaft while the gaging plastic is between the bearing and journal.
3. Install the bearing cap and evenly torque the retaining bolts to specifications. Bearing cap **MUST** be torqued to specifications in order to assure proper reading. Variations in torque affect the compression of the plastic gage.
4. Remove bearing cap. The flattened gaging plastic will be found adhering to either the bearing shell or journal.

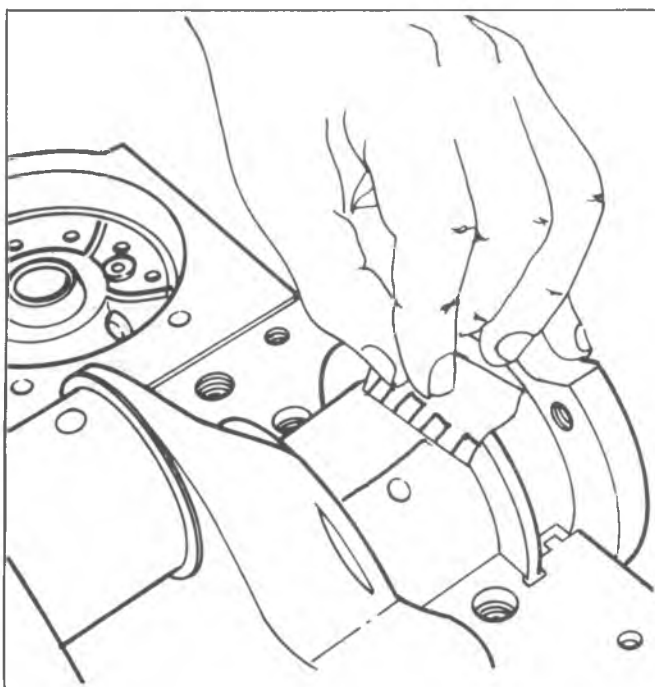

Fig. 6A5-45--Measuring Gaging Plastic

5. On the edge of gaging plastic envelope there is a graduated scale which is correlated in thousandths of an inch. Without removing the gaging plastic, measure its compressed width (at the widest point) with the graduations on the gaging plastic envelope (fig. 6A5-45).

Normally main bearing journals wear evenly and are not out-of-round. However, if a bearing is being fitted to an out-of-round (.001" max.), be sure to fit to the maximum diameter of the journal: If the bearing is fitted to the minimum diameter and the journal is out-of-round .001", interference between the bearing and journal will result in rapid bearing failure. If the flattened gaging plastic tapers toward the middle or ends, there is a difference in clearance indicating taper, low spot or other irregularity of the bearing or journal. Be sure to measure the journal with a micrometer if the flattened gaging plastic indicates more than .001" difference.

6. If the bearing clearance is within specifications, the bearing insert is satisfactory. If the clearance is not within specifications, replace the insert. Always replace both upper and lower inserts as a unit. If a new bearing cap is being installed and clearance is less than .001", inspect for burrs or nicks; if none are found then install shims as required.
7. A standard, .001" or .002" undersize bearing may produce the proper clearance. If not, it will be necessary to regrind the crankshaft journal for use with the next undersize bearing. After selecting new bearing, recheck clearance.
8. Proceed to the next bearing. After all bearings have been checked rotate the crankshaft to see that there is no excessive drag. When checking #1 main bearing, loosen accessory drive belts so as to prevent tapered reading with plastic gage.

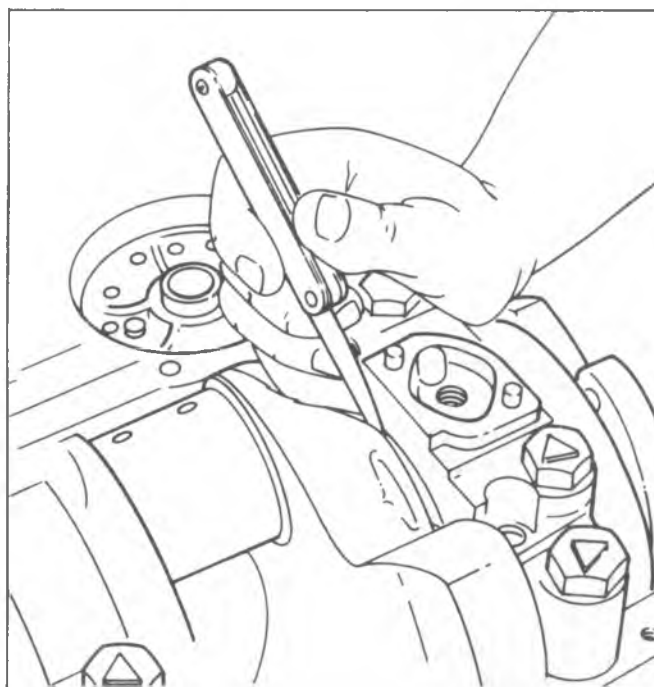

Fig. 6A5-46--Measuring Crankshaft End Play



9. Measure crankshaft end play (see specifications) by forcing the crankshaft to the extreme front position. Measure at the front end of the rear main bearing with a feeler gage (fig. 6A5-46).
10. Install a new rear main bearing oil seal in the cylinder block and main bearing cap.

### Replacement

Main bearings may be replaced with or without removing the crankshaft.

#### With Crankshaft Removal

1. Remove and inspect the crankshaft.
2. Remove the main bearings from the cylinder block and main bearing caps.
3. Coat bearing surfaces of new, correct size, main bearings with oil and install in the cylinder block and main bearing caps.
4. Install the crankshaft.

#### Without Crankshaft Removal

1. With oil pan, oil pump and spark plugs removed, remove cap on main bearing requiring replacement and remove bearing from cap.
2. Install a main bearing removing and installing tool in oil hole in crankshaft journal. If such a tool is not available, a cotter pin may be bent as required to do the job.
3. Rotate the crankshaft clockwise as viewed from the front of engine. This will roll upper bearing out of block.
4. Oil new selected size upper bearing and insert plain (unnotched) end between crankshaft and indented or notched side of block. Rotate the bearing into place and remove tool from oil hole in crankshaft journal.
5. Oil new lower bearing and install in bearing cap.
6. Install main bearing cap with arrows pointing toward front of engine.
7. Torque all main bearing caps EXCEPT THE REAR MAIN BEARING CAP to specifications. Torque rear main bearing cap to 10-12 lb. ft. (14-16N·m) then tap end of crankshaft, first rearward then forward with a lead hammer. This will line up rear main bearing and crankshaft thrust surfaces. Retorque all main bearing caps to specifications.

## OIL SEAL (REAR MAIN)

### Replacement

- Always replace the upper and lower seal as a unit.

The rear main bearing oil seal can be replaced (both halves) without removal of the crankshaft. Extreme care should be exercised when installing this seal to protect the sealing bead located in the channel on the outside diameter of the seal. An installation tool (fig. 6A5-47) can be used to protect the seal bead when positioning seal as follows:

1. With the oil pan and oil pump removed, remove the rear main bearing cap.
2. Remove oil seal from the bearing cap by prying from the bottom with a small screw driver (fig. 6A5-48).

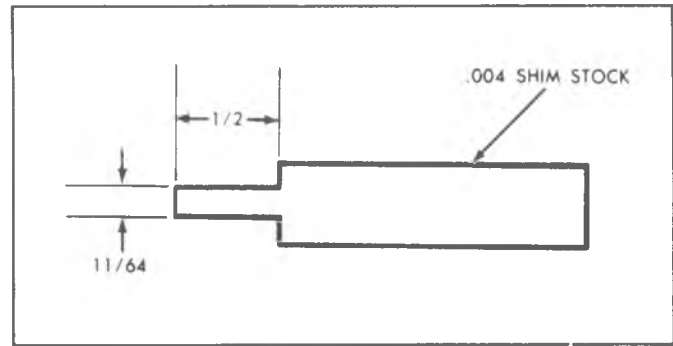

Fig. 6A5-47--Oil Seal Installation Tool

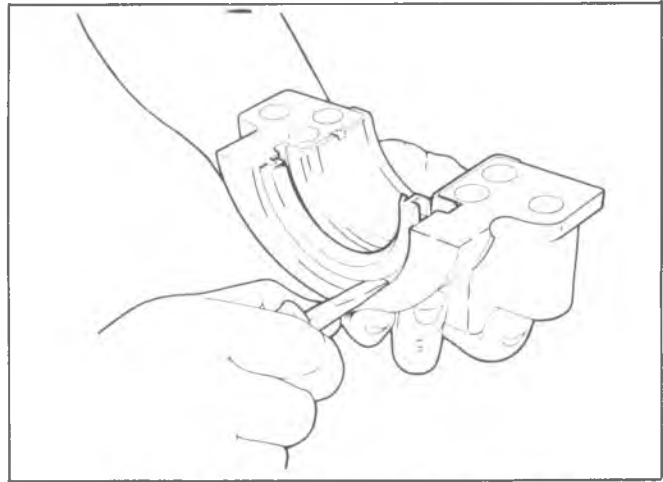

Fig. 6A5-48--Removing Oil Seal - Lower Half

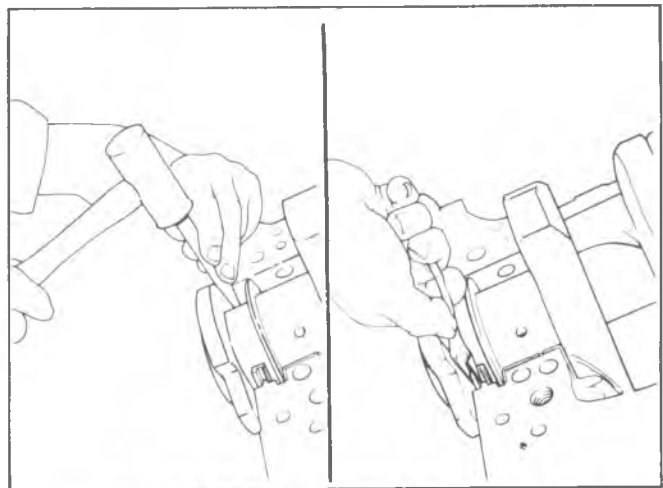

Fig. 6A5-49--Removing Oil Seal - Upper Half

3. To remove the upper half of the seal, use a small hammer to tap a brass pin punch on one end of seal until it protrudes far enough to be removed with pliers (fig. 6A5-49).
4. Clean all sealant and foreign material from cylinder case bearing cap and crankshaft, using a non-abrasive cleaner.
5. Inspect components for nicks, scratches, burrs and machining defects at all sealing surfaces, case assembly and crankshaft.
6. Coat seal lips and seal bead with light engine oil - keep oil off seal mating ends.

7. Position tip of tool between crankshaft and seal seat in cylinder case.
8. Position seal between crankshaft and tip of tool so that seal bead contacts tip of tool. Make sure that oil-seal lip is positioned toward front of engine (fig. 6A5-50).
9. Roll seal around crankshaft using tool as a "shoe-horn" to protect seal bead from sharp corner of seal seat surface in cylinder case. Installation tool must remain in position until seal is properly positioned with both ends flush with block.
10. Remove tool, being careful not to withdraw seal.
11. Install seal half in bearing cap, again using tool as a "shoe-horn", feeding seal into cap using light pressure with thumb and finger.
12. Install bearing cap to case with sealant applied to the cap-to-case interface being careful to keep sealant off the seal split line (fig. 6A5-51).
13. Install the rear main bearing cap (with new seal) and torque to 10-12 lb. ft. (14-16N·m). Tap end of crankshaft first rearward then forward with lead hammer. This will line up thrust surfaces. Retorque bearing cap to specifications.

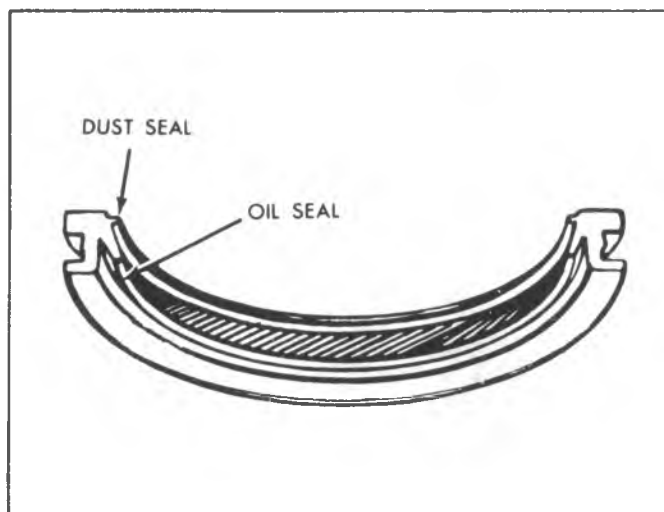

Fig. 6A5-50--Crankshaft Oil Seal - Rear Main

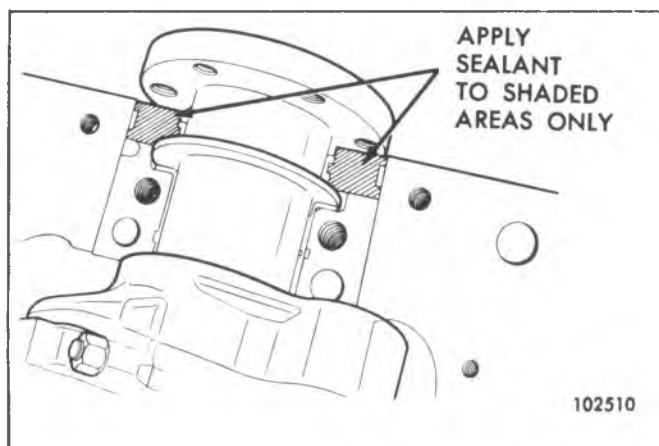

Fig. 6A5-51--Sealing Bearing Cap

## CONNECTING ROD AND PISTON ASSEMBLIES

### Removal

1. Remove oil pan, oil pump and cylinder head as previously outlined.
2. For the cylinder being serviced, turn crankshaft until piston is at the bottom of the stroke. Place a cloth on top of the piston.
3. Use a ridge reamer to remove any ridge and/or deposits from the upper end of the cylinder bore.
4. Turn crankshaft until piston is at top of stroke and remove cloth and cuttings.
5. Remove connecting rod cap and install Tool J-5329 (3/8") on studs. Push connecting rod and piston assembly out of top of cylinder block. It will be necessary to turn the crankshaft slightly to disconnect some of the connecting rod and piston assemblies and push them out of the cylinder.

### Disassembly

1. Remove connecting rod bearings from connecting rods and caps. If bearings are being reused, place them in a rack so they may be reinstalled in their original rod and cap.
2. Remove piston rings by expanding and sliding them off the pistons.
3. Place connecting rod and piston assembly on Tool J-24086-20. Using an arbor press and piston pin remover, J-24086-8, press the piston pin out of connecting rod and piston (fig. 6A5-52).

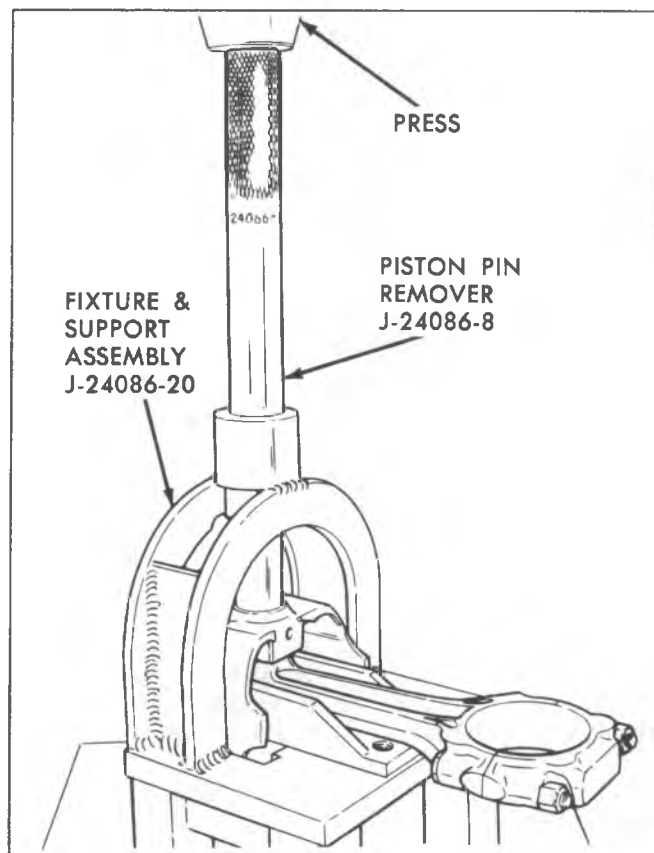

Fig. 6A5-52--Removing Piston Pin

## Cleaning and Inspection

### Connecting Rods

Wash connecting rods in cleaning solvent and dry with compressed air. Check for twisted or bent rods and inspect for nicks or cracks. Replace connecting rods that are damaged.

### Pistons

Clean varnish from piston skirts and pins with a cleaning solvent. **DO NOT WIRE BRUSH ANY PART OF THE PISTON.** Clean the ring grooves with a groove cleaner and make sure oil ring holes and slots are clean.

Inspect the piston for cracked ring lands, skirts or pin bosses, wavy or worn ring lands, scuffed or damaged skirts, eroded areas at top of the piston. Replace pistons that are damaged or show signs of excessive wear.

Inspect the grooves for nicks or burrs that might cause the rings to hang up.

Measure piston skirt (across center line of piston pin) and check clearance.

### Piston Pins

The piston pin clearance is designed to maintain adequate clearance under all engine operating conditions. Because of this, the piston and piston pin are a matched set and not serviced separately.

Inspect piston pin bores and piston pins for wear. Piston pin bores and piston pins must be free of varnish or scuffing when being measured. The piston pin should be measured with a micrometer and the piston pin bore should be measured with a dial bore gage or an inside micrometer. If clearance is in excess of the .001" wear limit, the piston and piston pin assembly should be replaced.

### Assembly

1. Lubricate piston pin holes in piston and connecting rod to facilitate installation of pin.
2. Place connecting rod in piston and hold in place with piston pin guide and piston pin. Place assembly on fixture and support assembly.
3. Using piston pin installer, J-24086-9, press the piston pin into the piston and connecting rod (fig. 6A5-53).

**NOTICE:** After installer hub bottoms on support assembly, do not exceed 5000 psi pressure, as this could cause structural damage to the tool.

4. Remove piston and connecting rod assembly from tool and check piston for freedom of movement on piston pin.

### Piston Rings

All compression rings are marked on the upper side of the ring. When installing compression rings, make sure the marked side is toward the top of the piston. The top ring is treated with molybdenum for maximum life.

The 2nd compression ring is a chrome plated, tapered face, reverse twist design.

The oil control rings are of three piece type, consisting of two segments (rails) and an expander.

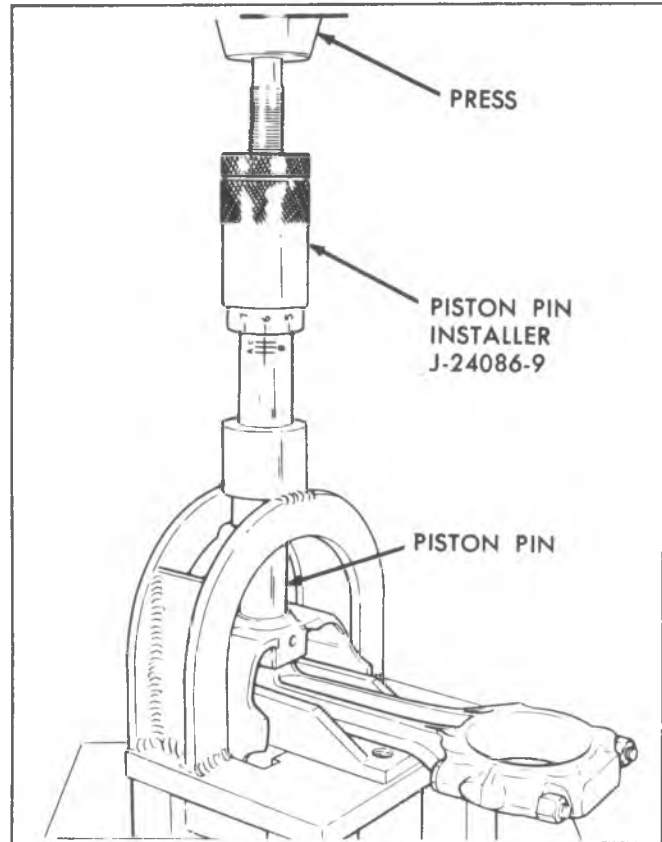

Fig. 6A5-53--Installing Piston Pin

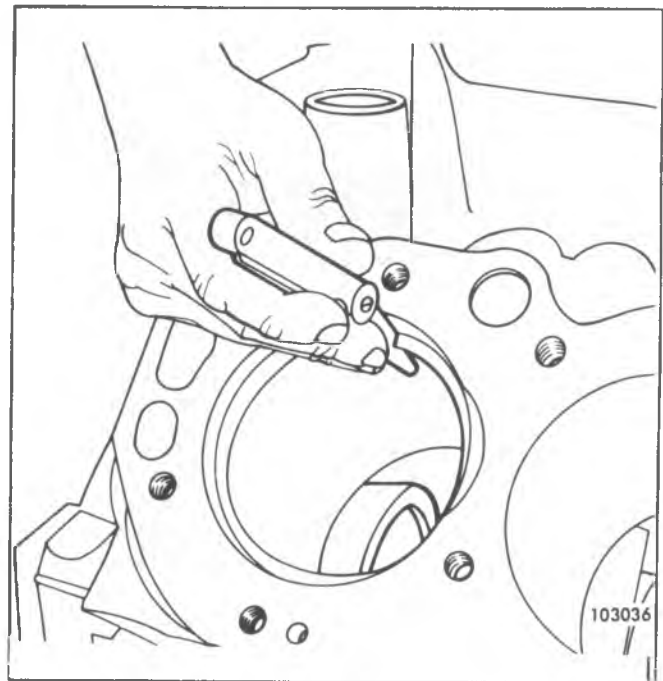

Fig. 6A5-54--Measuring Ring Gap

1. Select rings comparable in size to the piston being used.
2. Slip the compression ring in the cylinder bore; then press the ring down into the cylinder bore about 1/4" (6.5mm) (above ring travel). Be sure ring is square with cylinder wall.
3. Measure the space or gap between the ends of the ring with a feeler gage (fig. 6A5-54).

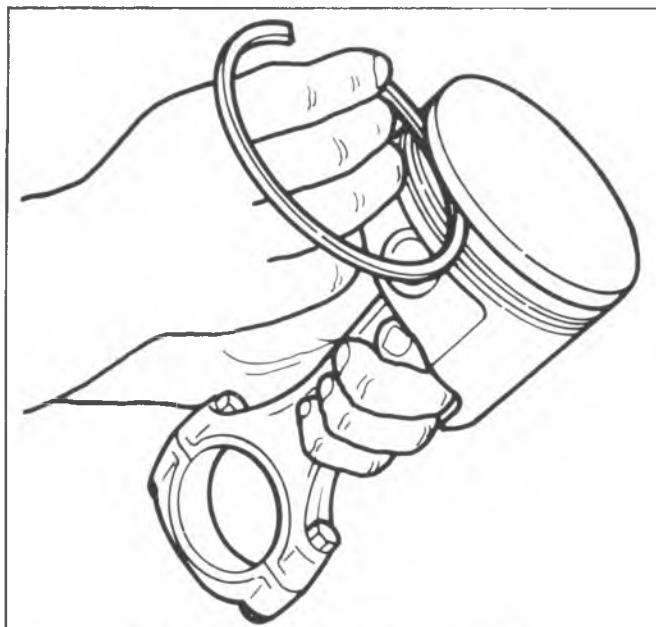

Fig. 6A5-55--Checking Ring in Groove

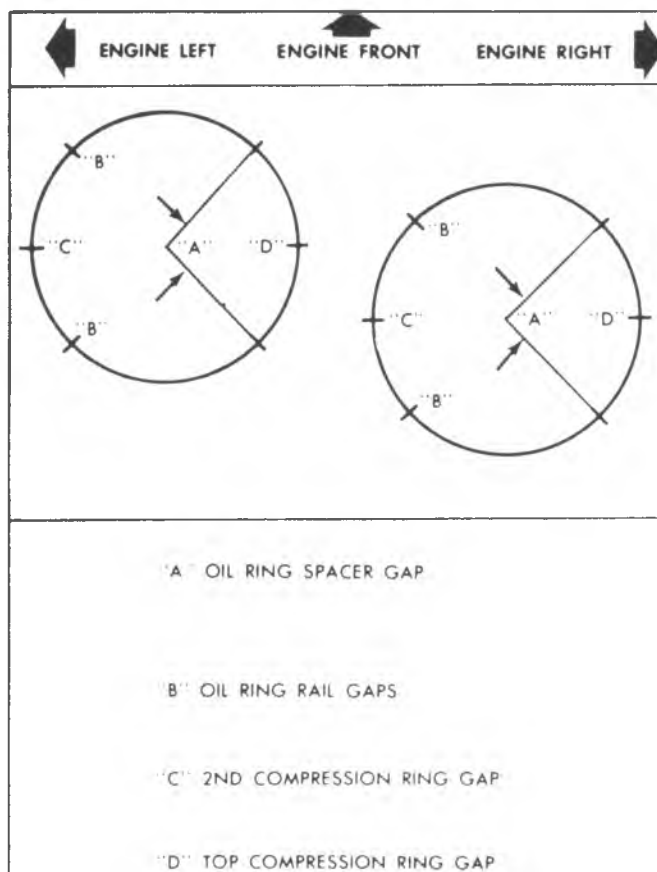

Fig. 6A5-56--Ring Gap Location

4. If the gap between the ends of the ring is below specifications, remove the ring and try another for fit.
5. Fit each compression ring to the cylinder in which it is going to be used.
6. If the pistons have not been cleaned and inspected as previously outlined, do so.
7. Slip the outer surface of the top and second compression ring into the respective piston ring groove and roll

the ring entirely around the groove (fig. 6A5-55) to make sure that the ring is free. If binding occurs at any point, the cause should be determined. If binding is caused by ring groove, correct by dressing with a fine cut file. If the binding is caused by a distorted ring, check a new ring.

8. Install piston rings as follows (fig. 6A5-56):
  - a. Install oil ring spacer in groove.
  - b. Hold spacer ends butted and install lower steel oil ring rail with gap properly located.
  - c. Install upper steel oil ring rail with gap properly located.
  - d. Flex the oil ring assembly to make sure ring is free. If binding occurs at any point the cause should be determined. If binding is caused by ring groove, correct by dressing groove with a fine cut file. If binding is caused by a distorted ring, check a new ring.
  - e. Install second compression ring then properly locate gaps.
  - f. Install top compression ring with gap properly located.
  
9. Proper clearance of the piston ring in its piston ring groove is very important to provide proper ring action and reduce wear. Therefore, when fitting new rings, the clearances between the surfaces of the ring and groove should be measured (fig. 6A5-57). (See Specifications).

**Installation**

Cylinder bores must be clean before piston installation. This may be accomplished with a hot water and detergent wash or with a light honing as necessary. After cleaning, the bores should be swabbed several times with light engine oil and a clean dry cloth.

1. Lubricate connecting rod bearings and install in rods and rod caps.

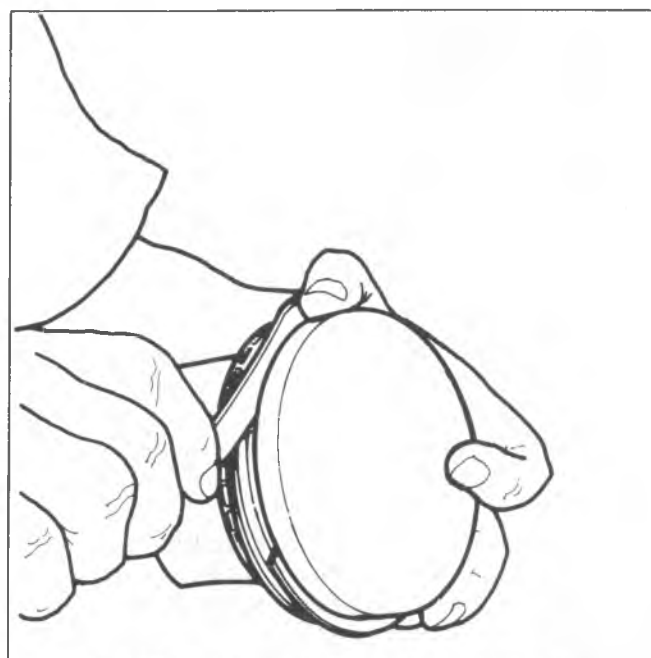

Fig. 6A5-57--Measuring Ring Groove Clearance

2. Lightly coat pistons, rings and cylinder walls with light engine oil.
3. With bearing caps removed, install Tool J-5329 (3/8") on connecting rod bolts.
4. Install each connecting rod and piston assembly in its respective bore. Install with connecting rod bearing tang slots on side opposite camshaft. Use Tool J-8037 to compress the rings. Guide the connecting rod into place on the crankshaft journal with Tool J-6305 (11/32"). Use a hammer handle and light blows to install the piston into the bore. Hold the ring compressor firmly against the cylinder block until all piston rings have entered the cylinder bore.
5. Remove Tool J-5329.
6. Install the bearing caps and torque nuts to specifications.

Be sure to install new pistons in the cylinders for which they were fitted, and used pistons in the cylinder from which they were removed. Each connecting rod and bearing cap should be marked, beginning at the front of the engine. Cylinders 1,3,5 and 7 in the left bank and, 2,4, 6 and 8 in the right bank. The numbers on the connecting rod and bearing cap must be on the same side when installed in the cylinder bore. If a connecting rod is ever transposed from one block or cylinder to another, new bearings should be fitted and the connecting rod should be numbered to correspond with the new cylinder number.

## CYLINDER BLOCK

### Cleaning and Inspection

1. Wash cylinder block thoroughly in cleaning solvent and clean all gasket surfaces.
2. Remove oil gallery plugs and clean all oil passages.
3. Clean and inspect water passages in the cylinder block.
4. Inspect the cylinder block for cracks in the cylinder walls, water jacket, valve lifter bores and main bearing webs.
5. Measure the cylinder walls for taper, out-of-round or excessive ridge at top of ring travel. This should be done with a dial indicator. Set the gage so that the thrust pin must be forced in about 1/4" (6.5mm) to enter gage in cylinder bore. Center gage in cylinder and turn dial to "0". Carefully work gage up and down cylinder to determine taper and turn it to different points around cylinder wall to determine the out-of-round condition. If cylinders were found to exceed specifications, honing or boring will be necessary.

### Conditioning

The performance of the following operation is contingent upon engine condition at time of repair.

If the cylinder block inspection indicated that the block was suitable for continued use except for out-of-round or tapered cylinders, they can be conditioned by honing or boring.

If the cylinders were found to have less than .005" taper or wear, they can be conditioned with a hone and fitted with the high limit standard size piston. A cylinder bore of less than .005" wear or taper may not entirely clean up when fitted to a high limit piston. If it is desired to entirely clean up the bore in these cases, it will be necessary to rebore for

an oversize piston. If more than .005" taper or wear, they should be bored and honed to the smallest oversize that will permit complete resurfacing of all cylinders.

When pistons are being fitted and honing is not necessary, cylinder bores may be cleaned with a hot water and detergent wash. After cleaning, the cylinder bores should be swabbed several times with light engine oil and a clean cloth and then wiped with a clean dry cloth.

### Boring

1. Before using any type boring bar, the top of the cylinder block should be filed off to remove any dirt or burrs. This is very important. If not checked, the boring bar may be tilted which would result in the rebored cylinder wall not being at right angles to the crankshaft.
2. The piston to be fitted should be measured with a micrometer, measuring at the center of the piston skirt and at right angles to the piston pin. The cylinder should be bored to the same diameter as the piston and honed to give the specified clearance.
3. The instructions furnished by the manufacturer of the equipment being used should be carefully followed.

### Honing

1. When cylinders are to be honed, follow the hone manufacturer's recommendations for the use of the hone and cleaning and lubrication during honing.
2. Occasionally during the honing operation, the cylinder bore should be thoroughly cleaned and the piston selected for the individual cylinder checked for correct fit.
3. When finish honing a cylinder bore to fit a piston, the hone should be moved up and down at a sufficient speed to obtain very fine uniform surface finish marks, in a cross-hatch pattern of approximately 45° to 65° included angle. The finish marks should be clean but not sharp, free from imbedded particles and torn or folded metal.
4. Permanently mark the piston for the cylinder to which it has been fitted and proceed to hone cylinders and fit the remaining pistons.

**NOTICE:** Handle the pistons with care and do not attempt to force them through the cylinder until the cylinder has been honed to correct size as this type piston can be distorted through careless handling.

5. Thoroughly clean the bores with hot water and detergent. Scrub well with a stiff bristle brush and rinse thoroughly with hot water. It is extremely essential that a good cleaning operation be performed. If any of the abrasive material is allowed to remain in the cylinder bores, it will rapidly wear the new rings and cylinder bores in addition to the bearings lubricated by the contaminated oil, the bores should be swabbed and then wiped with a clean dry cloth. Cylinder should not be cleaned with kerosene or gasoline. Clean the remainder of the cylinder block to remove the excess material spread during the honing operation.

### Piston Selection

1. Check USED piston to cylinder bore clearance as follows:

- a. Measure the "Cylinder Bore Diameter" with a telescope gage [[2-1/2" (64mm) from top of cylinder bore]].
  - b. Measure the "Piston Diameter" (at skirt across center line of piston pin).
  - c. Subtract piston diameter from cylinder bore diameter to determine "Piston to Bore Clearance".
  - d. Locate piston to bore clearance on Piston Selection Chart and determine if piston to bore clearance is in the acceptable range.
2. If used piston is not acceptable, determine if a new piston can fit cylinder bore.
  3. If cylinder bore must be reconditioned, measure new piston diameter (across center line of piston pin) then hone cylinder bore to correct clearance.
  4. Mark the piston to identify the cylinder for which it was fitted.

## OIL FILTER BYPASS VALVE

### Inspection and Replacement

With the oil filter removed, check the spring and fibre valve for operation. Inspect for a cracked, broken or stuck valve. If replacement is necessary, the oil filter adapter and bypass valve assembly must be replaced as an assembly. Clean valve chamber in cylinder block thoroughly. Torque retaining screws to specifications.

## ENGINE ASSEMBLY

### Removal

1. Remove hood.
2. Disconnect battery cables at battery.
3. Remove air cleaner.
4. Drain radiator and block.
5. Disconnect radiator and heater hoses and remove radiator and fan shroud.
6. Disconnect wires at:
  - Starter Solenoid
  - Generator
  - TRC Speed Switch
  - TRC Solenoid
  - Temperature switch
  - Oil Pressure Switch
  - Distributor
7. Disconnect:
  - Accelerator linkage at inlet manifold.
  - Fuel line, from tank, at fuel pump.
  - Hoses at fuel vapor storage canister (if applicable).
  - Vacuum line to power brake unit at manifold, if so equipped.
8. Remove power steering pump and A/C compressor and lay aside, if so equipped.
9. Raise vehicle on hoist.
10. Drain crankcase.
11. Disconnect exhaust pipe at manifold and, if so equipped, converter bracket at transmission rear mount.
12. Remove starter.
13. Remove flywheel splash shield or converter housing cover as applicable.
14. On vehicles with automatic transmission, remove converter to flywheel attaching bolt.
15. Remove mount "through" bolts.
16. Remove bell housing bolts.
17. Lower vehicle on hoist.
18. Raise transmission using floor jack.
19. Attach engine lifting devices, raise engine.
20. Remove motor mount to engine brackets.
21. Remove engine assembly.

### Installation

1. Position engine assembly in vehicle.
  2. Attach motor mount to engine brackets and lower engine in place.
  3. Remove engine lifting device.
  4. Remove transmission floor jack.
  5. Raise vehicle on hoist.
  6. Install mount "through" bolts. Torque to specifications.
  7. Install bell housing bolts. Torque to specifications.
  8. On vehicles with automatic transmissions, install converter to flywheel attaching bolts. Torque to specifications.
  9. Install flywheel splash shield of converter housing cover as applicable. Torque attaching bolts to specifications.
  10. Install starter.
  11. Connect exhaust pipe at manifold and converter bracket at transmission rear mount.
  12. Lower vehicle on hoist.
  13. Reinstall power steering pump and A/C compressor, if so equipped.
  14. Connect:
    - Accelerator linkage at inlet manifold.
    - Fuel line, from tank, at fuel pump.
    - Hoses at fuel vapor storage canister.
    - Vacuum line to power brake unit at manifold, if equipped.
  15. Connect wires at:
    - Starter Solenoid
    - Generator
    - TRC Speed Switch
    - TRC Solenoid
    - Temperature Switch
    - Oil Pressure Switch
    - Distributor
  16. Install radiator and fanshroud and reconnect radiator and heater hoses.
  17. Fill cooling system.
  18. Fill crankcase with oil. See Section 0B for specifications.
  19. Install air cleaner.
  20. Install hood.
  21. Connect battery cables.
- NOTICE:** To avoid possible arcing of battery, connect positive battery cable first.

22. Start engine, check for leaks and check timing.

## CRANKSHAFT

The crankshaft can be removed while the engine is disassembled for overhaul, as previously outlined or without complete disassembly as outlined below.

### Removal

1. With the engine removed from the vehicle and the transmission and/or clutch housing removed from the engine, mount engine in stand and clamp securely.
2. Remove the oil dip stick and oil dip stick tube, (if applicable).
3. Remove the starting motor, clutch assembly (if equipped) and flywheel.
4. Remove the spark plugs.
5. Remove crankshaft pulley and torsional damper.
6. Remove oil pan and oil pump.
7. Remove crankcase front cover, and if so equipped, remove timing chain and camshaft sprocket.
8. Check the connecting rod caps for cylinder number identification. If necessary, mark them.
9. Remove the connecting rod caps and push the pistons to top of bores.
10. Remove main bearing caps and lift crankshaft out of cylinder block.
11. Remove rear main bearing oil seal and main bearings from cylinder block and main bearing caps.

### Cleaning and Inspection

1. Wash crankshaft in solvent and dry with compressed air.
2. Measure dimensions of main bearing journals and crankpins with a micrometer for out-of-round, taper or undersize. (See Specifications.)
3. Check crankshaft for run-out by supporting at the front and rear main bearings journals in "V" blocks and check at the front and rear intermediate journals with a dial indicator. (See Specifications.)
4. Replace or recondition the crankshaft if out of specifications.

## SPROCKET OR GEAR REPLACEMENT

Remove crankshaft sprocket using Tool J1619, install using Tool J-21058.

### Installation

1. Install rear main bearing oil seal in cylinder block and rear main bearing cap grooves. Install with lip of seal

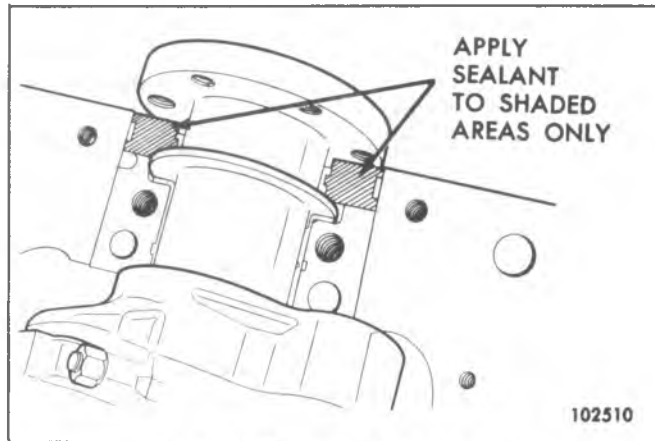

Fig. 6A5-58--Sealing Bearing Cap

- toward front of engine. Where seal has two lips install lip with helix towards front of engine.
2. Lubricate lips of seal with engine oil. Keep oil off parting line surface.
3. Install main bearings in cylinder block and main bearing caps then lubricate bearing surface with engine oil.
4. Install crankshaft, being careful not to damage bearing surfaces.
5. Apply a thin coat of brush-on type oil sealing compound to block mating surface and corresponding surface of cap only (fig. 6A5-58). Do not allow sealant on crankshaft or seal.
6. Install main bearing caps with arrows pointing toward front of engine.
7. Torque all except rear main bearing cap bolts to specifications. Torque rear main bearing cap bolts to 10-12 lbs. ft. (14-16 N·m) then tap end of crankshaft, first rearward then forward with a lead hammer. This will line up rear main bearing and crankshaft thrust surfaces. Retorque all main bearing cap bolts to specifications.
8. Measure crankshaft end play with a feeler gage. Force crankshaft forward and measure clearance between the front of the rear main bearing and the crankshaft thrust surface.
9. Install flywheel and torque to specifications. A wood block placed between the crankshaft and cylinder block will prevent crankshaft from rotating.
  - Align dowel hole in flywheel with dowel hole in crankshaft. On vehicles equipped with automatic transmissions, install flywheel with the converter attaching pads towards transmission.

**GENERAL DATA:**

|                   |           |                  |
|-------------------|-----------|------------------|
| TYPE              |           | 90° V-8 GASOLINE |
| DISPLACEMENT      | LITRE (*) | 7.4 (M)          |
| RPO               |           | LE8              |
| BORE              |           | 4.250            |
| STROKE            |           | 4.000            |
| COMPRESSION RATIO |           | 8.0:1            |
| FIRING ORDER      |           | 1-8-4-3-6-5-7-2  |

**CYLINDER BORE:**

|              |            |               |            |
|--------------|------------|---------------|------------|
| DIAMETER     |            | 4.2495-4.2525 |            |
| OUT OF ROUND | PRODUCTION | .001 MAX.     |            |
|              | SERVICE    | .002 MAX.     |            |
| TAPER        | PRODUCTION | THRUST SIDE   | .0005 MAX. |
|              |            | RELIEF SIDE   | .001 MAX.  |
|              | SERVICE    |               | .001 MAX.  |

**PISTON:**

|           |            |             |
|-----------|------------|-------------|
| CLEARANCE | PRODUCTION | .0030-.0040 |
|           | SERVICE    | .0050 MAX.  |

**PISTON RING:**

|   |                  |                           |                           |                           |
|---|------------------|---------------------------|---------------------------|---------------------------|
| C<br>O<br>M<br>P<br>R<br>E<br>S<br>S<br>I<br>O<br>N | GROOVE CLEARANCE | PRODUCTION                | TOP                       | .0017-.0032               |
|   |                  |                           | 2ND                       | .0017-.0032               |
|   |                  | SERVICE                   |                           | HI LIMIT PRODUCTION +.001 |
|   | GAP              | PRODUCTION                | TOP                       | .010-.020                 |
| 2ND   |                  |                           | .010-.020                 |                           |
| SERVICE   |                  | HI LIMIT PRODUCTION +.010 |                           |                           |
| O<br>I<br>L   | GROOVE CLEARANCE | PRODUCTION                | .005-.0065                |                           |
|   |                  | SERVICE                   | HI LIMIT PRODUCTION +.001 |                           |
|   | GAP              | PRODUCTION                | .015-.055                 |                           |
|   |                  | SERVICE                   | HI LIMIT PRODUCTION +.010 |                           |

\* VIN Designation

**PISTON PIN**

**LE8**

|            |            |                          |
|------------|------------|--------------------------|
| DIAMETER   |            | .9895-.9898              |
| CLEARANCE  | PRODUCTION | .00025-.00035            |
|            | SERVICE    | .001 MAX.                |
| FIT IN ROD |            | .0013-.0021 INTERFERENCE |

**CRANKSHAFT**

|                        |              |             |                                |
|------------------------|--------------|-------------|--------------------------------|
| MAIN JOURNAL           | DIAMETER     |             | #1-2-3-4 2.7481-2.7490         |
|                        |              |             | #5 2.7476-2.7486               |
|                        | TAPER        | PRODUCTION  | .0002 MAX.                     |
|                        |              | SERVICE     | .001 MAX.                      |
| OUT OF ROUND           | PRODUCTION   | .0002 MAX.  |                                |
|                        | SERVICE      | .001 MAX.   |                                |
| MAIN BEARING CLEARANCE | PRODUCTION   |             | #1-2-3-4 .0013-.0025           |
|                        |              |             | #5 .0024-.0040                 |
|                        | SERVICE      |             | #1-4 .001-.0025 #5 .0025-.0035 |
| CRANKSHAFT END PLAY    |              | .006-.010   |                                |
| CRANKPIN               | DIAMETER     |             | 2.2000-2.1990                  |
|                        | TAPER        | PRODUCTION  | .0005                          |
|                        |              | SERVICE     | .001 MAX.                      |
|                        | OUT OF ROUND | PRODUCTION  | .0005                          |
| SERVICE                |              | .001 MAX.   |                                |
| ROD BEARING CLEARANCE  | PRODUCTION   | .0009-.0025 |                                |
|                        | SERVICE      | .0030 MAX.  |                                |
| ROD SIDE CLEARANCE     |              | .013-.023   |                                |

**CAMSHAFT**

|                     |         |               |
|---------------------|---------|---------------|
| LOBE LIFT<br>± .002 | INTAKE  | .2343         |
|                     | EXHAUST | .2530         |
| JOURNAL DIAMETER    |         | 1.9482-1.9492 |



SPECIFICATIONS

VALVE SYSTEM

LE8

|                          |                          |                               |                |
|--------------------------|--------------------------|-------------------------------|----------------|
| LIFTER                   |                          | HYDRAULIC                     |                |
| ROCKER ARM RATIO         |                          | 1.70:1                        |                |
| VALVE LASH               | INTAKE                   | ONE TURN DOWN FROM ZERO LASH  |                |
|                          | EXHAUST                  |                               |                |
| FACE ANGLE (INT. & EXH.) |                          | 45°                           |                |
| SEAT ANGLE (INT. & EXH.) |                          | 46°                           |                |
| SEAT RUNOUT              |                          | .002 MAX.                     |                |
| SEAT WIDTH               | INTAKE                   | 1/32-1/16                     |                |
|                          | EXHAUST                  | 1/16-3/32                     |                |
| STEM CLEARANCE           | PRODUCTION               | INT.                          | .0010-.0027    |
|                          |                          | EXH.                          | .0012-.0029    |
|                          | SERVICE                  | HI LIMIT + .001 IN. +.002 EX. |                |
| VALVE SPRING (OUTER)     | FREE LENGTH              |                               | 2.12           |
|                          | PRESSURE LBS. @ IN.      | CLOSED                        | 84-96 @ 1.80   |
|                          |                          | OPEN                          | 210-230 @ 1.40 |
|                          | INSTALLED HEIGHT ± 1/32" |                               | 1-51/64        |
| DAMPER                   | FREE LENGTH              |                               | 1.86           |
|                          | APPROX. # OF COILS       |                               | 4              |

TORQUE SPECIFICATIONS

|                                |               |
|--------------------------------|---------------|
| CRANKCASE FRONT COVER          | 80 LB. IN.    |
| FLYWHEEL HOUSING COVER         | 80 LB. IN.    |
| OIL FILTER BYPASS VALVE        | 80 LB. IN.    |
| OIL PAN (TO FRONT COVER)       | 55 LB. IN.    |
| OIL PUMP COVER                 | 80 LB. IN.    |
| ROCKER ARM COVER               | 50 LB. IN.    |
| CAMSHAFT SPROCKET              | 20 LB. FT.    |
| OIL PAN TO CRANKCASE (5/16-18) | 135 LB. IN.   |
| CLUTCH PRESSURE PLATE          | 30 LB. FT.    |
| DISTRIBUTOR CLAMP              | 25 LB. FT.    |
| FLYWHEEL HOUSING               | 30 LB. FT.    |
| MANIFOLD (EXHAUST)             | 20 LB. FT.    |
| MANIFOLD (INLET)               | 30 LB. FT.    |
| WATER OUTLET                   | 30 LB. FT.    |
| WATER PUMP                     | 30 LB. FT.    |
| CONNECTING ROD CAP             | 50 LB. FT.    |
| CYLINDER HEAD                  | 80 LB. FT.    |
| OIL PUMP                       | 65 LB. FT.    |
| ROCKER ARM STUD                | 50 LB. FT.    |
| FLYWHEEL                       | 65 LB. FT.    |
| MAIN BEARING CAP               | 110 LB. FT.   |
| TEMPERATURE SENDING UNIT       | 20 LB. FT.    |
| TORSIONAL DAMPER               | 85 LB. FT.    |
| OIL FILTER                     | 25 LB. FT.    |
| OIL PAN DRAIN PLUG             | 20 LB. FT.    |
| SPARK PLUG                     | 17-27 LB. FT. |

## 6.2L (C) V-8-RPO LH6

## 6.2L (J) V-8-RPO LL4

### DIESEL

NOTICE: DO NOT USE STARTING FLUIDS. SUCH AIDS CAN CAUSE IMMEDIATE ENGINE DAMAGE.

### CONTENTS

|   |    |  |    |
|---|----|--|----|
| General Description .....                 | 1  | Timing Chain .....                         | 16 |
| On Vehicle Service .....                  | 2  | Camshaft .....                             | 16 |
| Engine Mounts .....                       | 2  | Dipstick Tube .....                        | 19 |
| Exhaust Manifold .....                    | 6  | Oil Pan .....                              | 19 |
| Vacuum Pump .....                         | 6  | Oil Pump .....                             | 20 |
| Intake Manifold .....                     | 7  | Connecting Rod Bearings .....              | 20 |
| Rocker Arm Cover .....                    | 8  | Main Bearings .....                        | 22 |
| Rocker Arm And Shaft .....                | 9  | Oil Seal Rear Main .....                   | 23 |
| Valve Stem Oil Seal/Or Valve Spring ..... | 9  | Connecting Rod And Piston Assemblies ..... | 24 |
| Cylinder Head And Gasket .....            | 9  | Cylinder Block .....                       | 24 |
| Valves .....                              | 12 | Pistons .....                              | 25 |
| Valve Lifters .....                       | 13 | Crankshaft .....                           | 27 |
| Crankshaft Pulley .....                   | 15 | Engine Assembly .....                      | 28 |
| Torsional Damper .....                    | 15 | Specifications .....                       | 30 |
| Front Cover .....                         | 15 |  |    |

### GENERAL DESCRIPTION

The engine is a V-8, 6.2L engine. Cylinders #1, 3, 5, 7 are on the left bank and cylinders #2, 4, 6, 8 are on the right bank. The firing order is 1-8-7-2-6-5-4-3. This engine is similar to a V-8 gasoline engine in many ways but major differences occur in the cylinder heads, combustion chamber, fuel distribution system, air intake manifold and the method of ignition. The cylinder case, crankshaft, main bearings, rods, pistons and wrist pins are similar to a gasoline engine but are heavy duty design because of the high compression ratio required in the diesel engine to ignite fuel. Ignition of the fuel in a diesel engine occurs because of heat developed in the combustion chamber during the compression stroke. Thus, no spark plugs or high voltage ignition are necessary for a diesel engine.

Intake and exhaust valves in the cylinder heads operate the same as in a gasoline engine but are of special design and material for diesel operation. The special alloy steel pre-chamber inserts in the cylinder head combustion chambers are serviced separately from the head. With the cylinder head removed, they can be pushed out after removing the glow plugs and injection nozzles. Glow plugs and injector nozzles are threaded for assembly into the head. The injector nozzles are spring loaded and calibrated to open at a specified p.s.i. of fuel pressure.

Because the intake manifold is always open to atmospheric pressure, there is no vacuum supply and a vacuum pump is required to operate accessories such as air conditioning, door diaphragms and cruise control.

The engine is designed with a 101mm (3.98 inch) bore and a 97mm (3.8 inch) stroke, which produces 6217 CC (379.4 cubic inches). The compression ratio is 21.5 to 1. The cylinder head incorporates a 17 bolt head design which locates 5 bolts around each cylinder. This helps gasket durability.

The cylinder head includes a high swirl pre-combustion chamber which mixes fuel and air to provide an efficient fuel burn and low emissions. A glow plug is used to assist in starting this system. A special cavity in the piston top further assists in mixing the combustion products for complete burning.

Main bearing caps all use 4 bolts to provide a rigid support for the crankshaft and minimize stress.

The rolled fillet nodular iron crankshaft utilizes a torsional damper, tuned to reduce vibrations.

This engine uses roller hydraulic valve lifters running on a forged steel camshaft.

The fuel system includes a water sensor within the fuel tank which signals high water levels and a need for siphoning. Additional water separation, with a drain, is provided at the primary filter mounted on front of dash.

A block heater is standard equipment to aid starts in severe weather.

### LUBRICATION SYSTEM

Seven quarts of oil are required for this engine. The oil pan acts as a reservoir for holding the oil waiting to be circulated through the engine. The oil pan is attached to

the bottom side or pan rail of the engine.

The lubricating system of this engine is a pressure feed type which means that a pump forces oil through the galleries to the necessary parts. The pump is mounted to the bottom side of the rear main bearing cap. Extending down from the pump and into the oil is a pick-up tube with a screen cover to filter out foreign material. Oil is picked up by this tube and pumped through the oil pump. The pump is a gear type which uses 2 meshing gears. As these gears rotate in opposite directions, the spaces between the gear teeth and the housing fill with oil from the inlet side of the pump. Then as the teeth mesh, the oil is forced out through the outlet tube. The pump is driven from the engine camshaft by means of an intermediate shaft. The oil is next pumped through a cooler located in the radiator which cools the oil and thus helps to remove engine heat.

From the cooler the oil passes through a filter. This filter is a cartridge type and all oil going to the engine passes through this filter. The cartridge is made of materials that trap foreign material to prevent it getting to engine components. If this full flow filter becomes clogged, the engine is equipped with a by-pass valve which is spring loaded. This valve protects the engine from oil starvation by opening when increased pump pressure tries to pump oil through a clogged filter. When the pressure causes the by-pass valve to open, the oil by-passes the filter and the engine continues to receive lubrication. Replacement of the filter at proper intervals will prevent damage to the engine due to a clogged filter.

From the filter the oil is pumped through the drilled galleries in the case to the various moving metal parts in the engine. The rear crankshaft bearing is fed by a hole drilled from the rear main bearing bore to main gallery. Oil is pumped further through the main gallery to a drilled oil gallery which has been drilled the full length of the left side of the case. Oil from this gallery feeds the camshaft bearings and a second gallery which runs the full length of the right side of the case. All other engine components are provided lubrication by these 2 oil galleries. Holes are drilled from camshaft bore to crankshaft bore to provide oil for main bearings #1 through #4. Lifters on the right side receive oil from the right side main oil gallery and lifters on the left side receive oil from the left side oil gallery. The lifters contain a disc valve which meters oil to the hollow push rods and to the rocker arm and valve stem in the cylinder head. After a small accumulation of oil is in the head, it begins to drain back to the crankcase. As mentioned before, the first four main bearings receive oil from vertical holes drilled from the cam bores to crank bores. Oil flows onto the crankshaft main bearings and provides lubrication for the crankshaft to rotate freely in its bearings. As the crankshaft rotates, it slings oil off the crankpins to cover cylinder walls, pistons, piston pin and piston rings. Oil drains off these parts and back to the engine.

There is also a second by-pass valve. This is the oil cooler by-pass valve. It works much the same as the oil filter by-pass valve and opens to allow an alternate route for the oil if the cooler should become clogged.

There is an oil pressure switch which is assembled to the top rear of the cylinder case to sense oil pressure in the main gallery.

## COMPRESSION TEST

To determine if the valves or rings are the cause of low compression, a test should be made to determine the cylinder compression pressure.

When checking compression, the batteries should be at or near full charge. The lowest reading cylinder should not be less than 70 percent of the highest and no cylinder reading should be less than 275 p.s.i. (1900 kPa).

1. Remove air cleaner.
2. Disconnect the wire from the fuel solenoid terminal of the injection pump.
3. Disconnect wires from glow plugs then remove all glow plugs.
4. Screw the compression gage J-26999-10 into the glow plug hole of the cylinder that is being checked.
5. Crank engine.

This should be done with six "puffs" per cylinder.

Normal-Compression builds up quickly and evenly to specified compression on each cylinder.

Piston Rings Leaking-Compression low on first stroke tends to build up on following strokes but does not reach normal.

**NOTICE:** Do not add oil to any cylinder to compression test as extensive damage may result.

## ON VEHICLE SERVICE

Engine mounts (Figures 6A7-1 and 6A7-2) are the nonadjustable type and seldom require service. Broken or deteriorated mounts should be replaced immediately, because of the added strain placed on other mounts and drive line components.

### Checking Engine Mounts

Raise the engine to remove weight from the mounts and to place a slight tension in the rubber. Observe mounts while raising engine.

If a powertrain mount exhibits:

- a. Hard rubber surface covered with heat check cracks;
- b. Rubber separated from a metal plate of the mount; or
- c. Rubber split through center.

Replace the mount. If there is relative movement between a metal plate of the mount and its attaching points, lower the engine on the mounts and tighten the screws or nuts attaching the mount to the engine, frame, or bracket.

### Front Mount Replacement

1. Remove mount retaining bolt from below frame mounting bracket.
2. Raise front of engine and remove mount-to-engine bolts and remove mount. Raise engine only enough for sufficient clearance.
3. Replace mount to engine and lower engine into place.
4. Install retaining bolt and torque all bolts to specifications.

### Rear Mount Replacement

1. Support engine weight to relieve rear mounts.
2. Remove crossmember-to-mount bolts.

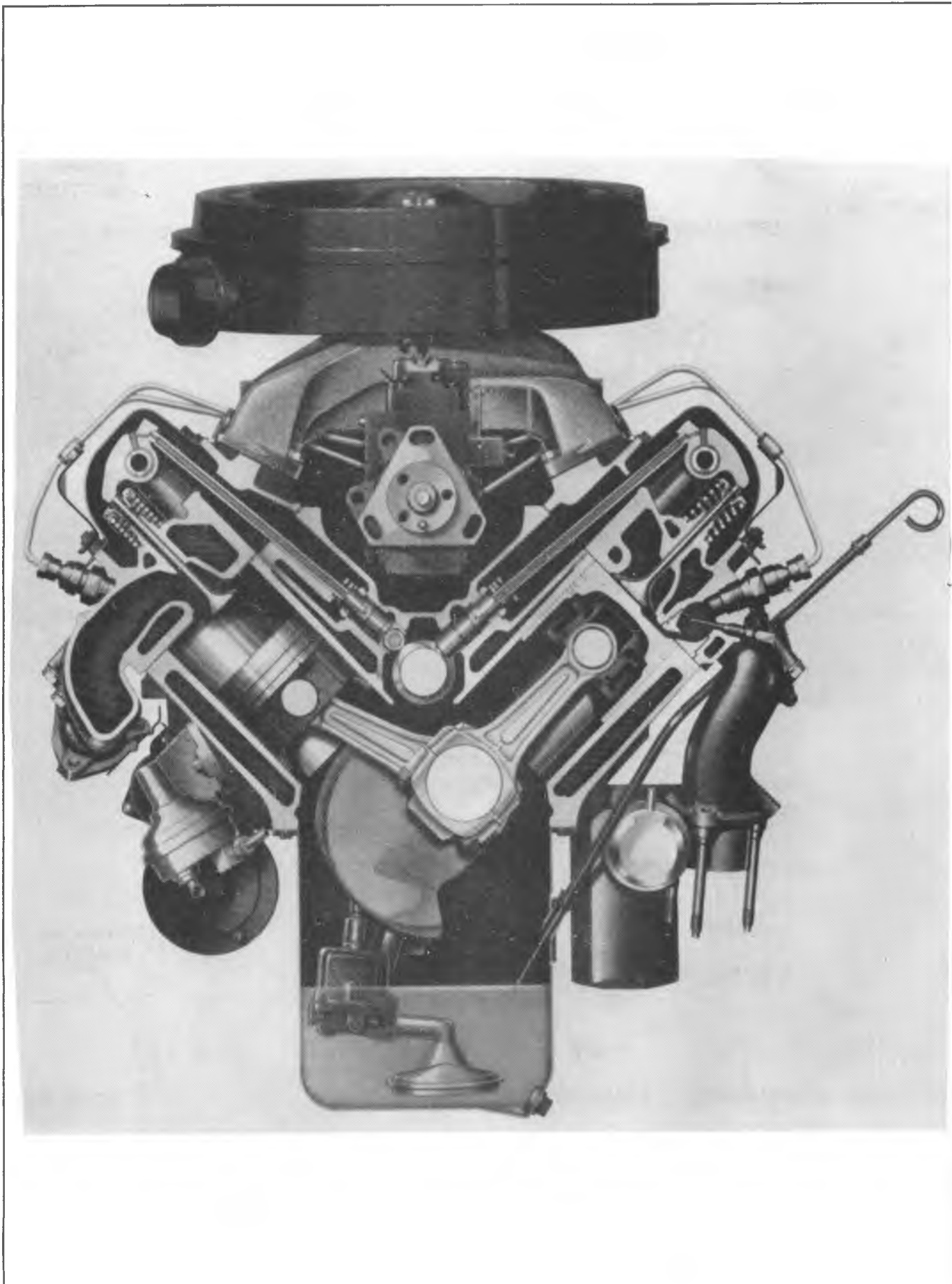

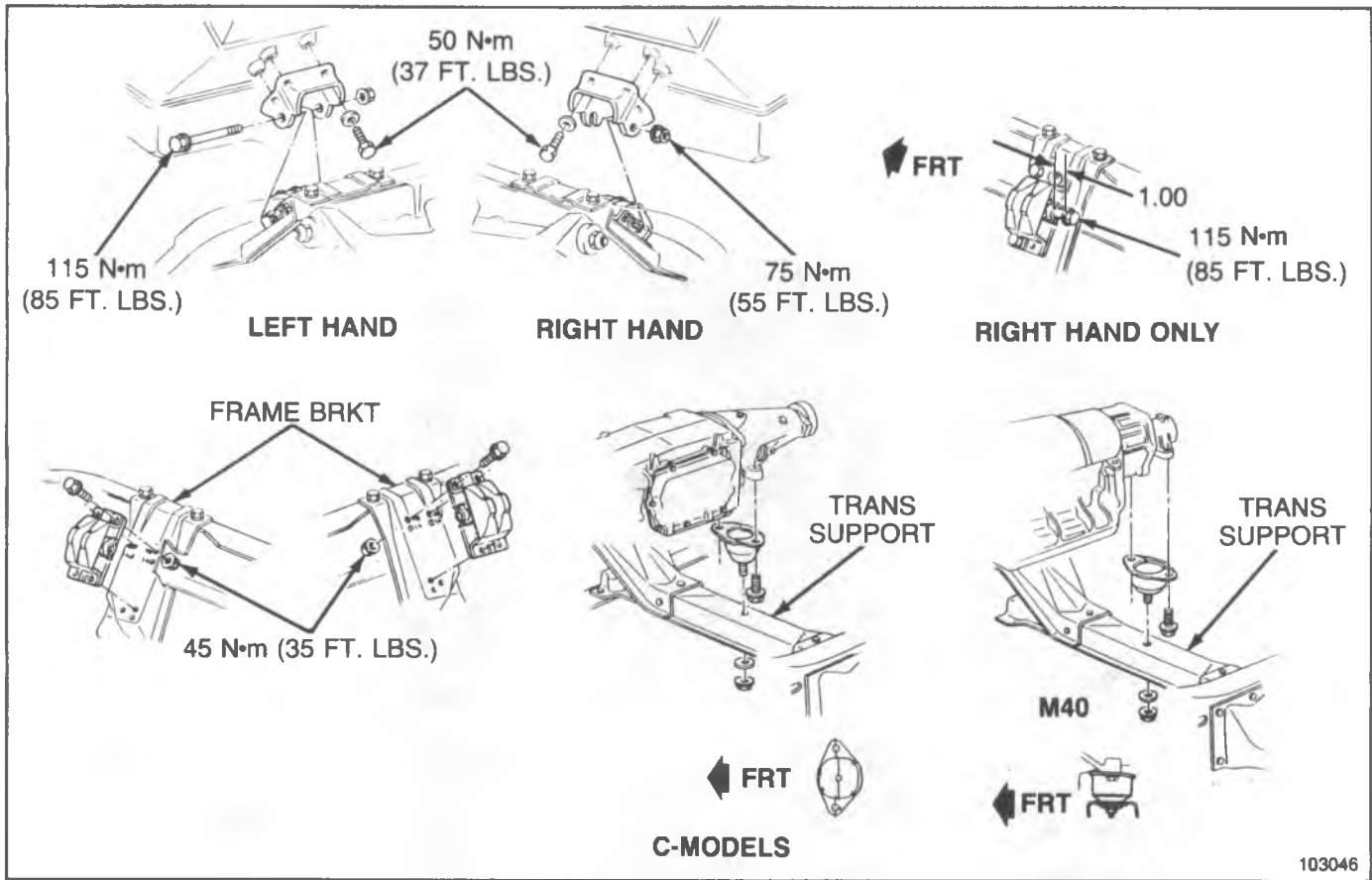

Fig. 6A7-1--Engine Mount C-Model

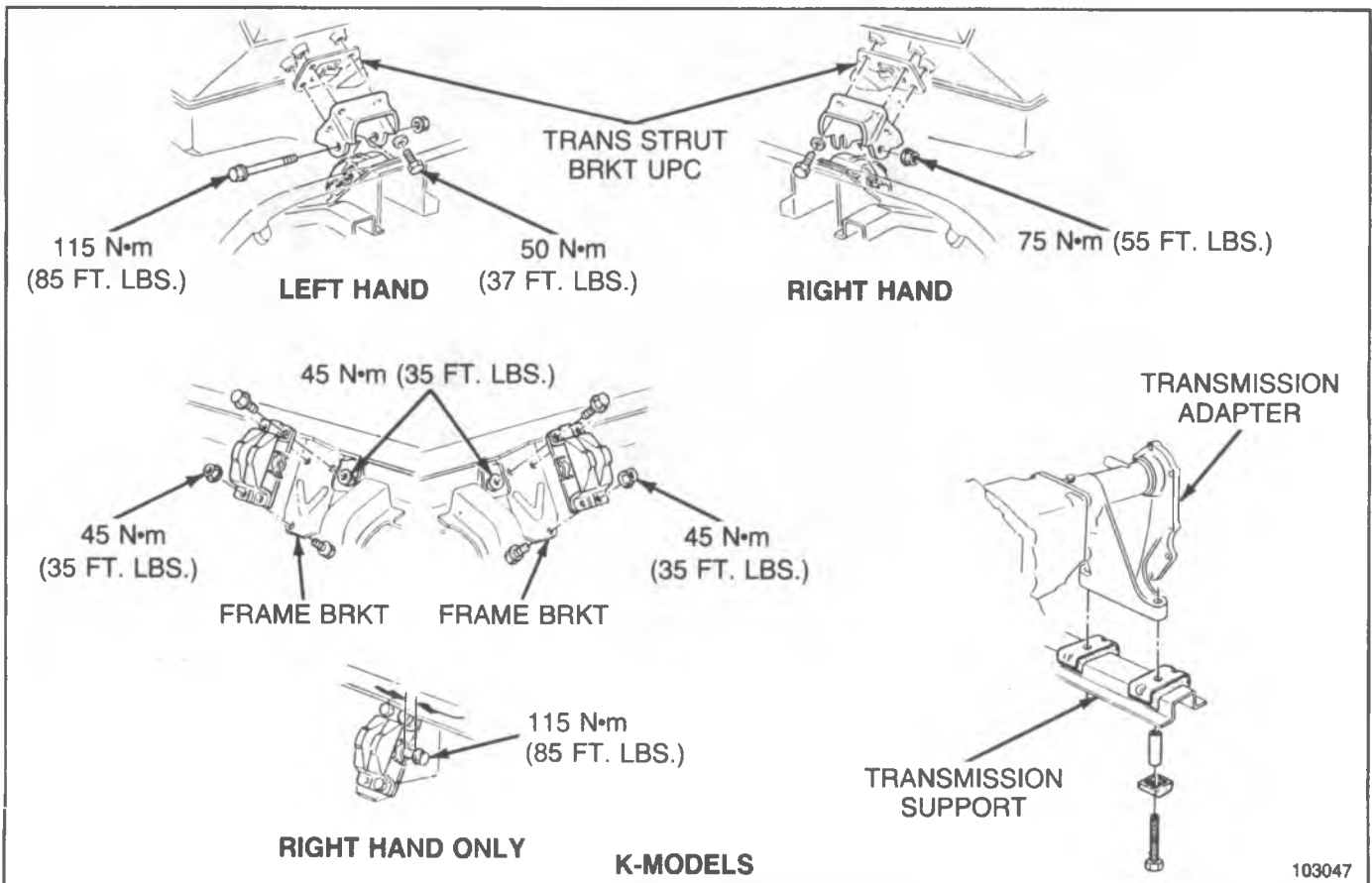

Fig. 6A7-2--Engine Mount K-Model

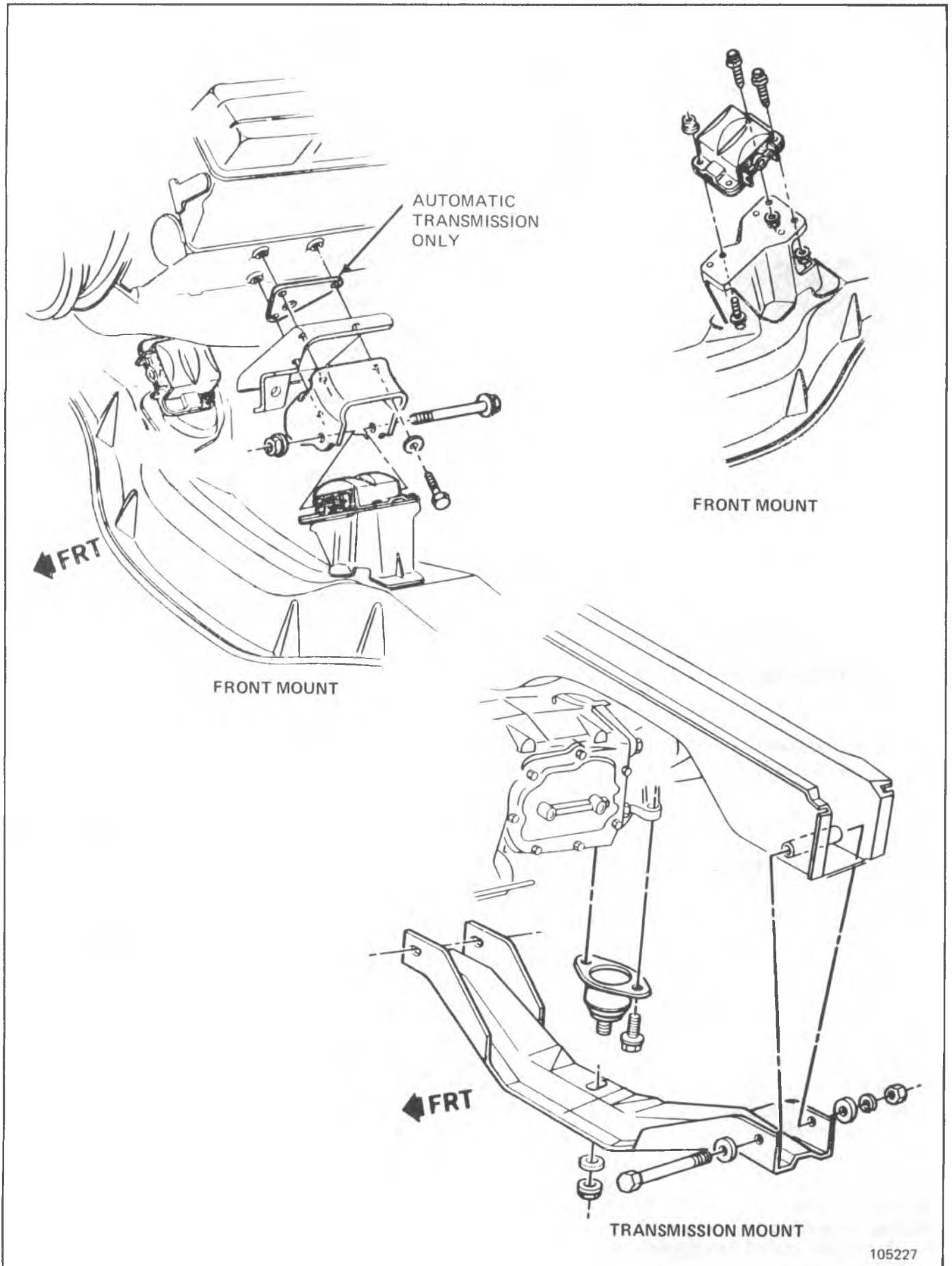

Fig. 6A7-2a--Engine Mount G-Model

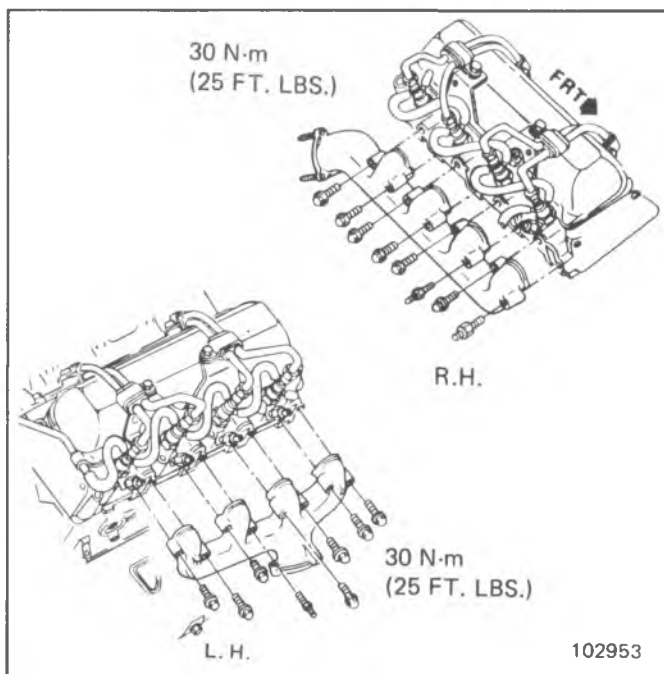

Fig. 6A7-3--Exhaust Manifold

3. Remove mount-to-transmission bolts, then remove mount.
4. Install new mount on transmission.
5. While lowering transmission, align and start crossmember-to-mount bolts.
6. Torque bolts to specifications, then bend lock tabs to bolt head as applicable.

### EXHAUST MANIFOLD (Fig. 6A7-3)

#### CK Truck

##### Removal and Installation (Right Side)

1. Disconnect batteries.
2. Raise vehicle.
3. Disconnect exhaust pipe from manifold.
4. Lower vehicle.
5. Disconnect glow plug wires.
6. Remove air cleaner duct bracket.
7. Remove glow plugs.
8. Remove manifold bolts.

To install, reverse removal procedures. Refer to figure 6A7-3 for proper bolt torque.

##### Removal and Installation (Left Side)

1. Disconnect batteries.
2. Remove dipstick tube nut.
3. Remove dipstick tube.
4. Disconnect glow plug wires.
5. Remove glow plugs.
6. Remove manifold bolts.
7. Raise vehicle.
8. Disconnect exhaust at manifold.
9. Remove manifold from bottom. Start manifold bolts while vehicle is raised then reverse removal procedures. Refer to figure 6A7-3 for proper bolt torque.

### G Van

##### Removal and Installation (Right Side)

1. Disconnect batteries.
2. Raise vehicle.
3. Disconnect exhaust pipe at manifold flange.
4. Lower vehicle.
5. Disconnect glow plug wires.
6. Remove manifold bolts.
7. Remove manifold.
8. For installation, reverse removal procedures.

##### Removal and Installation (Left Side)

1. Disconnect upper battery.
2. Raise vehicle.
3. Disconnect glow plug wires.
4. Lower vehicle.
5. Disconnect exhaust at manifold flange.
6. Remove manifold bolts.
7. Remove manifold.
8. For installation, reverse removal procedures.

### VACUUM PUMP (Fig. 6A7-4)

#### CK Truck

##### Removal

1. Disconnect batteries.
2. Remove air cleaner. Cover intake manifold.
3. Remove vacuum pump clamp.
4. Disconnect vacuum line.
5. Remove pump.

##### Installation

1. Install new gasket
2. Install vacuum pump as shown.
3. For remainder of installation reverse removal procedures.

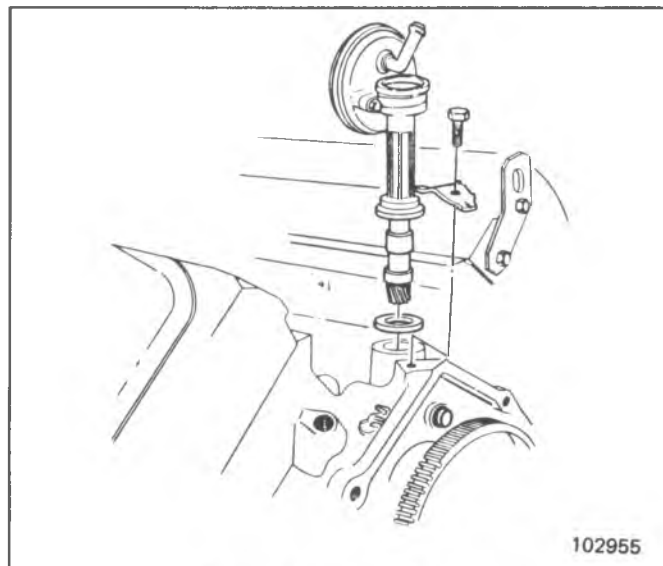

Fig. 6A7-4--Vacuum Pump

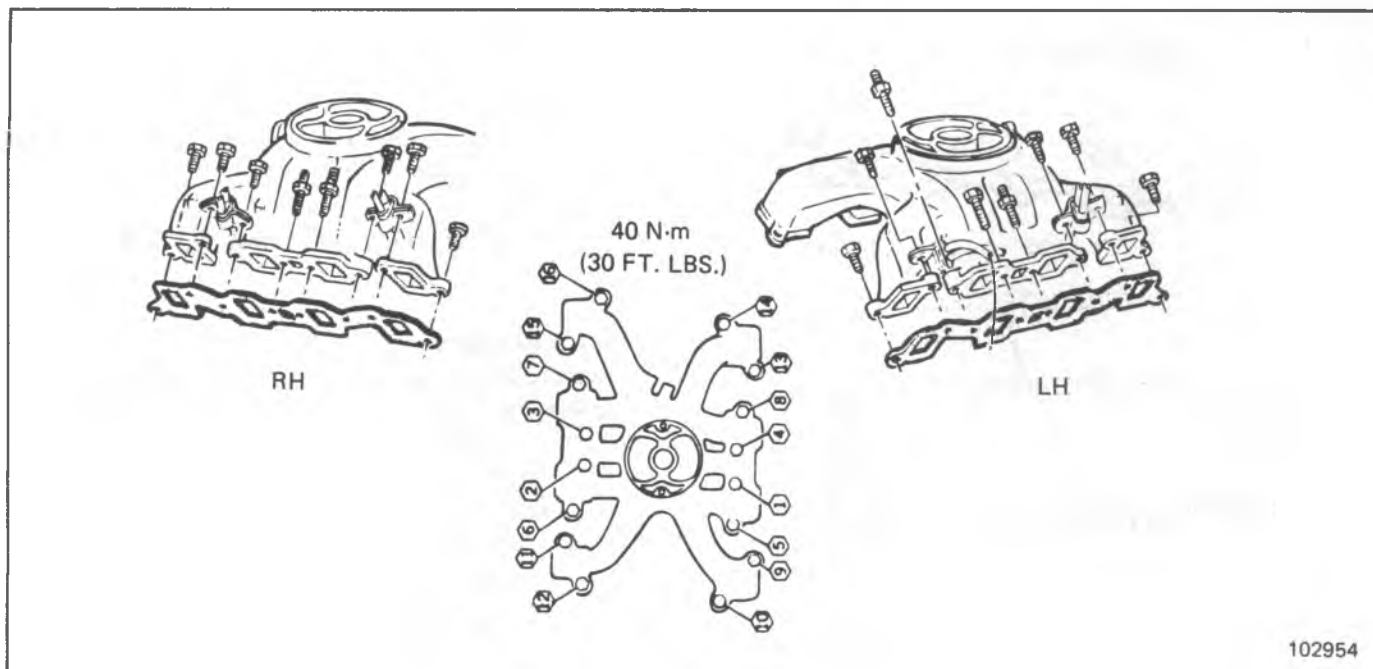

Fig. 6A7-5--Intake Manifold

**G Van****Removal**

1. Disconnect batteries.
2. Remove engine cover.
3. Disconnect vacuum lines.
4. Remove hold down clamp.
5. Remove vacuum pump. Place a rag or cover over hole to prevent foreign material from entering the engine.

**Installation**

1. Install new gasket.
2. Install vacuum pump as shown.
3. For remainder of installation, reverse removal procedures.

**INTAKE MANIFOLD (Fig. 6A7-5)****CK Truck****Removal**

1. Disconnect batteries.
2. Remove air cleaner.
3. Remove crankcase ventilator tubes.
4. Disconnect secondary filter lines.
5. Remove secondary filter and adapter.
6. Loosen vacuum pump hold down clamp and rotate pump in order to gain access to manifold bolt.
7. Remove EPR/EGR valve bracket, if equipped.
8. Remove rear A/C bracket, if equipped.
9. Remove intake manifold bolts. Injection line clips are retained by the same bolts.
10. Remove intake manifold.
11. If any further operations are to be performed install protective covers J-29664-1.

**Installation**

1. Remove protective covers after use.
2. Gasket surfaces must be clean prior to installation.
3. Install new gasket.  
Gasket has opening for EGR on light duty applications, and gasket has insert covering opening for heavy duty applications.
4. Install intake manifold.
5. Install intake manifold bolts in sequence as shown.
6. Fill secondary filter with clean diesel fuel prior to reinstallation.
7. Refer to 6.2 Diesel Fuel Injection Section for fuel line installation.
8. For the remainder of the installation procedures reverse removal.

**G Van****Removal**

1. Disconnect batteries.
2. Remove engine cover.
3. Remove air cleaner.
4. Disconnect necessary wires and hoses and remove EGR/EPR switches.
5. Remove crankcase depression regulator valve and disconnect hoses to valve.
6. Remove crankcase depression regulator valve hoses from intake manifold.
7. If equipped with air conditioning, remove rear compressor bracket.
8. Remove fuel filter to intake manifold bracket.
9. Remove vacuum pump, place a rag or cover over hole to prevent foreign material from entering the engine.
10. Remove intake bolts and fuel line clips.
11. Remove intake.



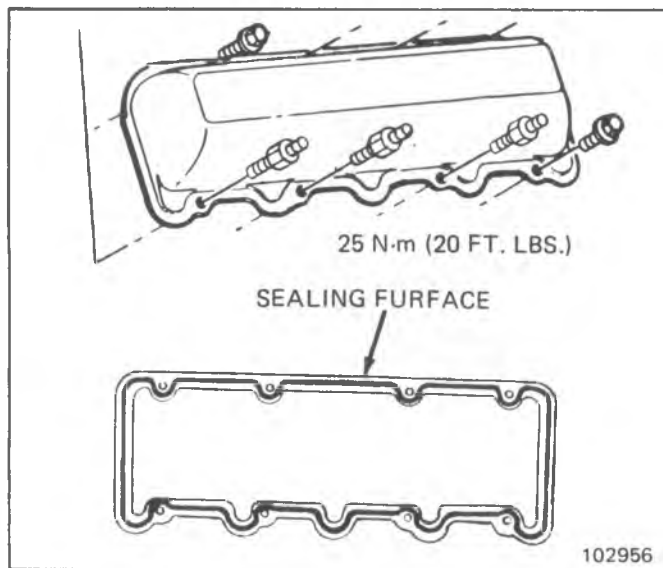

Fig. 6A7-6--Rocker Arm Cover

- If any further operations are to be performed, install protective covers J-29664-1.

#### Installation

- Remove protective covers after use.
- Gasket surfaces must be clean prior to installation.
- Install new gasket.  
Gasket has opening for EGR on light duty applications, and gasket has insert covering opening for heavy duty applications.
- Install intake manifold.
- Install intake manifold bolts in sequence shown.
- Refer to 6.2 Diesel Fuel Injection Section for fuel line installation.
- For remainder of the installation procedures, reverse removal.

### ROCKER ARM COVER (Fig. 6A7-6)

#### CK Truck

##### Removal

- Remove intake manifold as previously outlined.
- Remove injection lines as outlined in 6.2 Diesel Fuel Injection Section (#5 and #7 injection lines do not have to be removed for right side only).
- Remove wire loom from clip.
- Remove wire loom bracket (2 nuts).
- Remove rocker cover bolts and cover.

##### Installation

- Clean sealing surface on head and intake manifold.
- Place a 5mm diameter (3/16") bead of RTV sealant #1052734 or equivalent all around the rocker cover sealing surface. (When going around the attaching bolts holes always flow the sealant on the inboard side of the holes). Sealer must be wet to touch when bolts are torqued.

**NOTICE:** When applying sealant, keep sealant out of bolt holes as this could cause a "hydraulic" condition which could damage the head casting.

- Install the rocker cover bolts and studs.
- Install loom wire bracket.
- Install injection lines as outlined in 6.2 Diesel Fuel Injection Section.
- With protective covers J-29664-1 installed start engine and check for leaks at line fittings.
- Stop engine.
- Install intake manifold as previously outlined.

#### G Van

##### Removal (Right Side)

- Remove intake manifold as previously outlined.
- Remove injection lines as outlined in 6.2 Diesel Fuel Injection Section.
- Disconnect glow plug wires.
- Remove loom bracket nuts and remove bracket.
- Remove rocker cover bolts.
- Remove rocker cover.

##### Installation (Right Side)

- Clean sealing surface on head and intake manifold.
- Place a 5mm diameter (3/16") bead of RTV sealant #1052734 or equivalent all around rocker cover sealing surface. (When going around the attaching bolt holes, always flow the sealant on the inboard side of holes.) Sealer must be wet to touch when bolts are torqued.  
**NOTICE:** When applying sealant, keep sealant out of bolt holes as this could cause a "hydraulic" condition which could damage the head casting.
- Install rocker cover bolts and studs.
- Reverse removal procedures for the remainder of installation procedures.

##### Removal (Left Side)

- Remove intake manifold as previously outlined.
- Remove injection lines as outlined in 6.2 Diesel Fuel Injection Section. Before lowering vehicle, it may be necessary to remove other components mentioned below after injection line removal.
- If equipped with A/C:
  - Remove upper fan shroud.
  - Remove A/C belt.
  - Raise vehicle.
  - Disconnect exhaust at manifold flange.
  - Remove rear A/C brace from exhaust manifold and remove manifold.
  - Lower vehicle.
  - Discharge A/C system.
  - Disconnect A/C lines at compressor.
  - Remove A/C compressor from brackets and remove compressor.
- Loosen dipstick tube front bracket and remove from stud.
- Remove loom bracket nuts and remove brackets.
- Remove rocker cover bolts and disconnect fuel return bracket.
- Remove rocker cover.

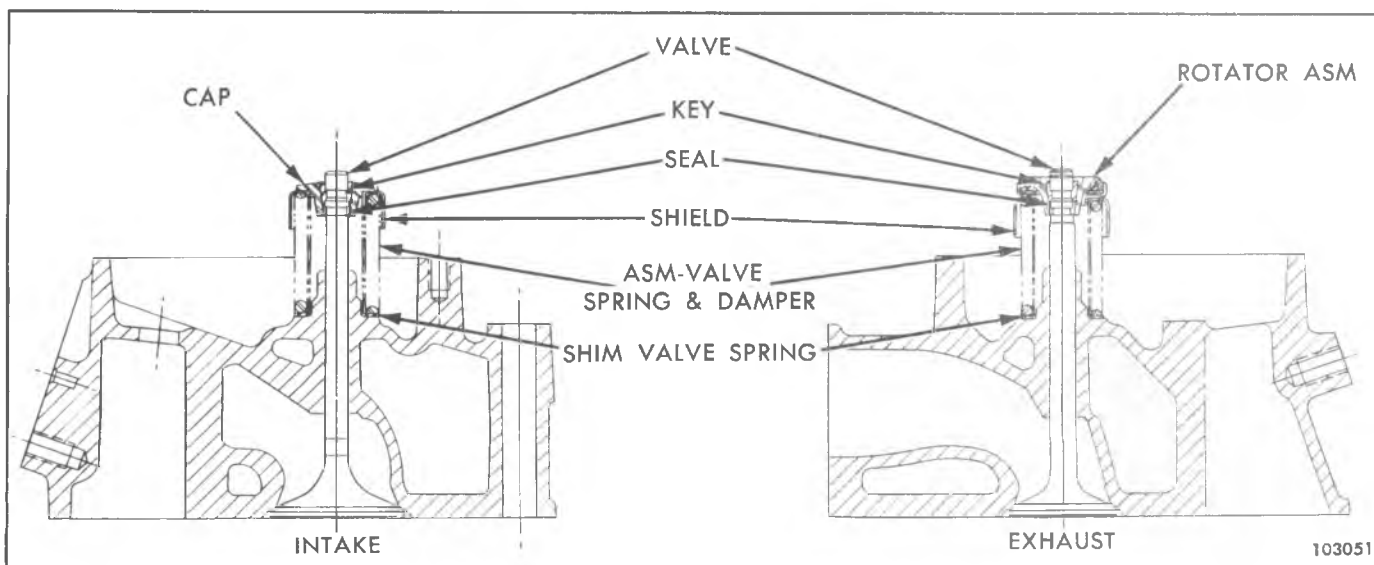

Fig. 6A7-8--Valve Assembly

**Installation (Left Side)**

Follow sealing procedures as outlined for right side installation.

Reverse removal procedures for remaining installation steps.

**ROCKER ARM AND SHAFT/PUSHRODS (Fig. 6A7-7)****CK Truck, G Van****Removal**

1. Remove rocker arm cover as previously outlined.
2. Remove rocker arm and shaft.
3. If rocker arm is to be removed, remove cotter pin and remove rocker arm from shaft.
4. At this time push rods can be removed. Push rod upper end must be identified for reinstallation.

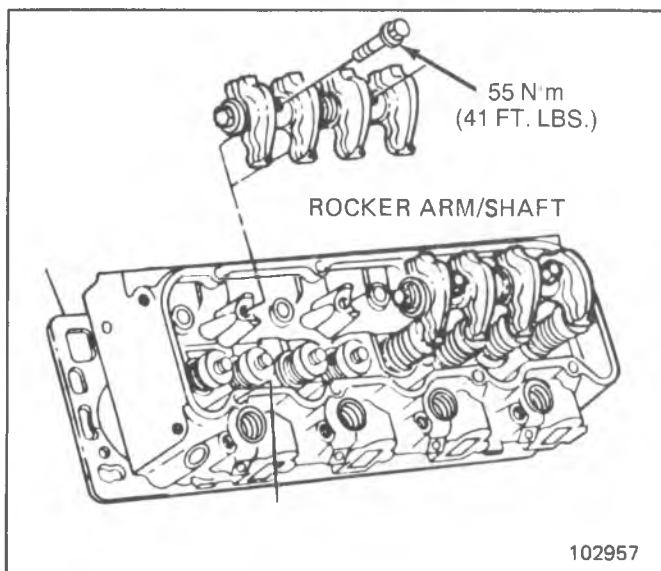

Fig. 6A7-7--Rocker Arm Shaft/Pushrods

**Installation**

1. If push rods were removed, install push rods.  
**NOTICE:** Push rods must be installed with painted or marked end up, failure to do so could cause premature wear or damage.
2. If rocker arms were removed from shaft, install rocker arms and spring in proper order.
3. Install rocker arm shaft assembly and torque bolt to 55 N·m (41 ft. lbs.).

**VALVE STEM OIL SEAL /OR VALVE SPRING****CK Truck, G Van**

To replace a worn or broken valve spring without removing the cylinder head proceed as follows:

**Removal**

1. Remove rocker arm assemblies.
2. Rotate engine so piston is at top dead center for each cylinder, or install air line adapter J-29666 to glow plug port and apply compressed air to hold valves in place.
3. Install Tool J-5892-1 or J-26513 and compress the valve spring until valve keys are accessible; then remove keys, valve cap or rotator, springs and seals. If valve spring does not compress, tap tool with a mallet to break bind at rotator and keys.

**Installation**

1. Install seal, valve spring and cap rotator. Using Tool J-5892-1 or J-26513, compress the valve spring until the valve keys can be installed.
2. Install rocker arm assemblies.

**CYLINDER HEAD AND GASKET (Fig. 6A7-9)****CK Truck****Removal**

1. Remove injection lines and intake manifold as previously outlined.
2. Remove rocker arm covers as previously outlined.

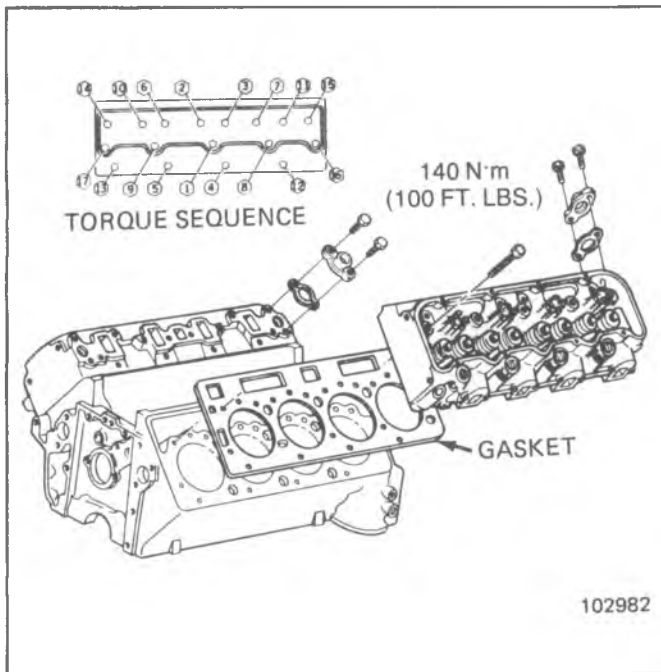

Fig. 6A7-9--Cylinder Head and Gasket

3. Drain coolant.
4. Remove dipstick tube (left side).
5. Disconnect ground wire at cowl (right side).
6. Raise vehicle
7. Disconnect exhaust pipe from manifold.
8. Lower vehicle.
9. If equipped with A/C remove compressor and lay aside (left side).
10. Remove generator and lay aside (right side).
11. Disconnect glow plug wires.
12. Remove rocker arm assemblies.
13. Remove push rods. Mark push rods for reinstallation. Place rocker arm shafts and push rods in a rack so they may be reinstalled in the same location.
14. Disconnect radiator, bypass, and heater hoses.
15. Disconnect ground strap.
16. Remove thermostat housing/crossover at cylinder head.
17. Remove cylinder head bolts (17 each side). Rear left cylinder head bolt may have to remain in head upon removal.
18. Remove cylinder head.

## G Van

### Removal (Right Side)

1. Remove intake manifold as previously outlined.
2. Remove injection lines as outlined in 6.2 Diesel Fuel Injection Section.
3. If equipped with cruise control, remove transducer.
4. If equipped with A/C, remove upper fan shroud.
5. If equipped with A/C, remove A/C belt.
6. Raise vehicle.
7. Disconnect exhaust at manifold flange.

8. If equipped with A/C, remove rear A/C brace from exhaust manifold.
9. Disconnect glow plug wires.
10. Lower vehicle.
11. If equipped with AC:
  - Discharge A/C system.
  - Disconnect A/C lines at compressor.
  - Remove A/C compressor from brackets and remove compressor.
12. Loosen dipstick tube front bracket and remove from stud.
13. Remove oil fill tube upper bracket.
14. Remove loom bracket.
15. Remove rocker cover bolts.
16. Remove rocker cover.
17. Remove rocker arm assemblies.
18. Remove push rods. Push rod upper end must be identified for reinstallation.
19. Drain cooling system.
20. Remove air cleaner resonator and bracket.
21. Remove transmission fill tube nut and position aside.
22. Disconnect heater, radiator and by-pass hoses at crossover.
23. Remove generator upper bracket.
24. Remove coolant crossover.
25. Remove cylinder head bolts.
26. Disconnect transmission dipstick at rear of head and remove tube.
27. Remove cylinder head.

### Removal (Left Side)

1. Remove intake manifold as previously outlined.
2. Remove injection lines at pump.
3. If equipped with cruise control, remove transducer.
4. If equipped with A/C, remove upper fan shroud.
5. If equipped with A/C, remove A/C belt.
6. Raise vehicle.
7. Disconnect exhaust at exhaust manifold flange.
8. Remove rear A/C brace from exhaust manifold and remove manifold.
9. Remove power steering lower adjusting bolts.
10. Disconnect glow plug wires and temperature switch.
11. Remove injection lines at nozzles, cap nozzles.
12. Lower vehicle.
13. If equipped with A/C:
  - Discharge A/C system.
  - Disconnect A/C lines at compressor.
  - Remove A/C compressor from bracket and remove compressor.
14. Remove upper power steering attachment and lay aside.
15. Loosen dipstick tube front bracket and remove stud.
16. Remove oil fill tube upper bracket.
17. Disconnect T.V. cable.
18. Remove glow plug controller and bracket.
19. Remove glow plug relay.

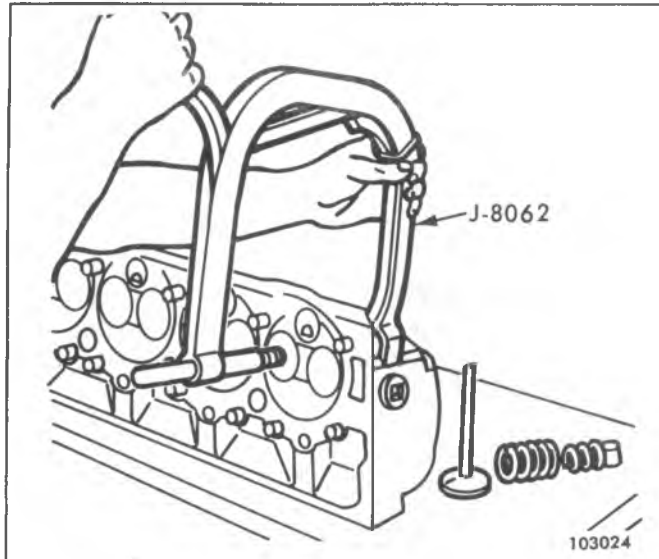

Fig. 6A7-10--Compressing Valve Spring

20. Disconnect oil pressure switch and loom.
21. Remove loom bracket.
22. Remove vacuum line clip bolt at head.
23. Remove rocker cover bolts and disconnect fuel return line bracket.
24. Remove rocker cover.
25. Remove rocker arm assembly.
26. Remove push rods. Push rod upper end must be identified for reinstallation.
27. Drain cooling system.
28. Remove air cleaner resonator and bracket.
29. Remove transmission fill tube nut and lay tube aside.
30. Disconnect heater, radiator and bypass hoses at crossover.
31. Remove generator upper bracket.
32. Remove coolant crossover.
33. Remove head bolts.
34. Remove cylinder head.

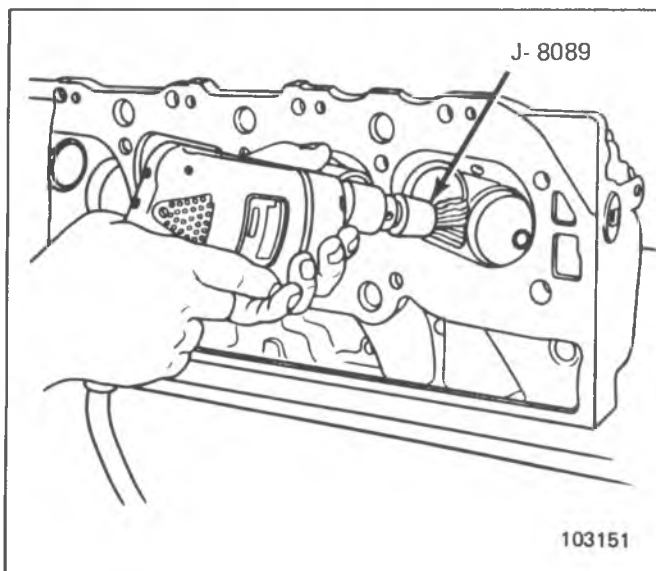

Fig. 6A7-11--Cleaning Combustion Chamber

### Disassembly

1. With cylinder head removed using tool J-8062, compress the valve springs (figure 6A7-10) and remove valve keys. Release the compressing tool and remove rotators or spring caps, springs and spring damper, then remove oil seal and valve spring shims.
2. Remove valves from cylinder head and place them in a rack in their proper sequence so that they can be assembled in their original positions.
3. If necessary to remove pre-chamber, remove the glow plug and injection nozzle then tap out with a small blunt nylon drift.

### Cleaning

1. Clean all carbon from combustion chambers and valve parts using tool J-8089 (figure 6A7-11).
2. Thoroughly clean valve guides using tool J-8101 (figure 6A7- ).
3. Clean all carbon and sludge from push rods, rocker arms and push rod guides.
4. Clean valve stems and heads on a buffing wheel.
5. Clean carbon deposits from the head gasket mating surface.

### Inspection

1. Inspect the cylinder head for cracks in the exhaust ports, combustion chambers, or external cracks to the coolant chamber.
2. Inspect the valves for burned heads, cracked faces or damaged stems. Inspect deck face for scratches or dents across gasket fire-ring area. Marks across coolant seal surfaces can be no deeper than .003".

**NOTICE:** Excessive valve stem to bore clearance will cause excessive oil combustion and may cause valve breakage. Insufficient clearance will result in noisy and sticky functioning of the valve and disturb engine smoothness.

3. Measure valve stem clearance (fig. 6A7-12) as follows:
  - a. Clamp a dial indicator on one side of the cylinder head rocker arm cover gasket rail.

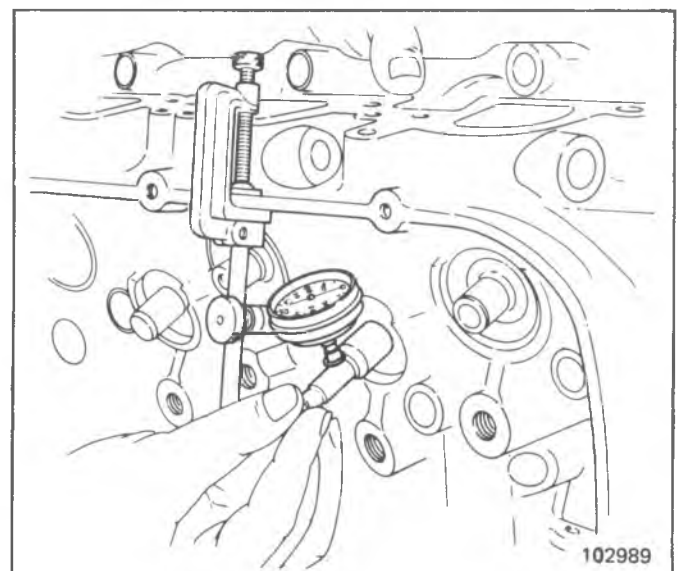

Fig. 6A7-12--Measuring Valve Stem Clearance

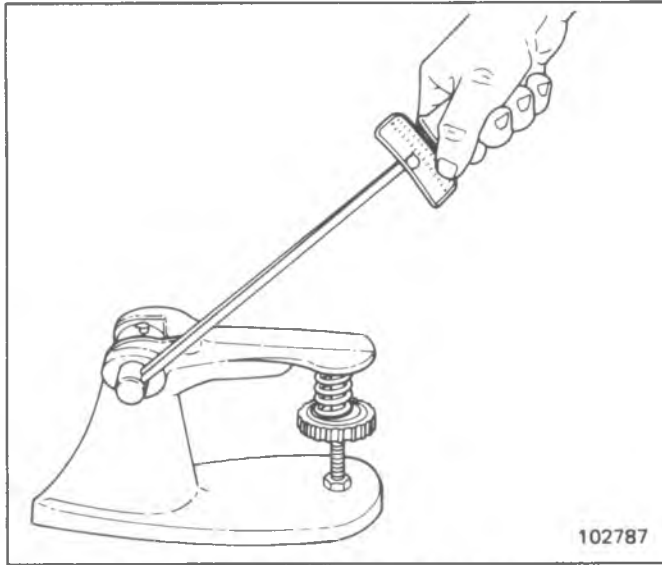

Fig. 6A7-13--Checking Valve Spring Tension.

- b. Locate the indicator so that movement of the valve stem from side to side (crosswise to the head) will cause a direct movement of the indicator stem. The indicator stem must contact the side of the valve stem just above the valve guide.
- c. Drop the valve head about 1/16" (1.6mm) off the valve seat.
- d. Move the stem of the valve from side to side using light pressure to obtain a clearance reading. If

clearance exceeds specifications, it will be necessary to ream valve guides for oversize valves as outlined.

4. Check valve spring tension with Tool J-8056 spring tester (Fig. 6A7-13). Springs should be compressed to the specified height and checked against the specifications chart. Springs should be replaced if not with 44 N (10 lbs.) of the specified load (without dampers).

#### VALVE GUIDE BORES

Valves with oversize stems are available (see specifications). To ream the valve guide bores for oversize valves use Tool Set J-7049.

#### VALVES

Valves that are pitted can be refaced to the proper angle, insuring correct relation between the head and stem on a valve refacing mechanism. Valve stems which show excessive wear, or valves that are warped excessively should be replaced. When a valve head which is warped excessively is refaced, a knife edge will be ground on part or all of the valve head due to the amount of metal that must be removed to completely reface. Knife edges lead to breakage, burning or pre-ignition due to heat localizing on this knife edge. If the edge of the valve head is less than 1/32" (.80mm) thick after grinding, replace the valve (fig. 6A7-14). Several different types of equipment are available for refacing valves. The recommendation of the manufacturer of the equipment being used should be carefully followed to attain proper results.

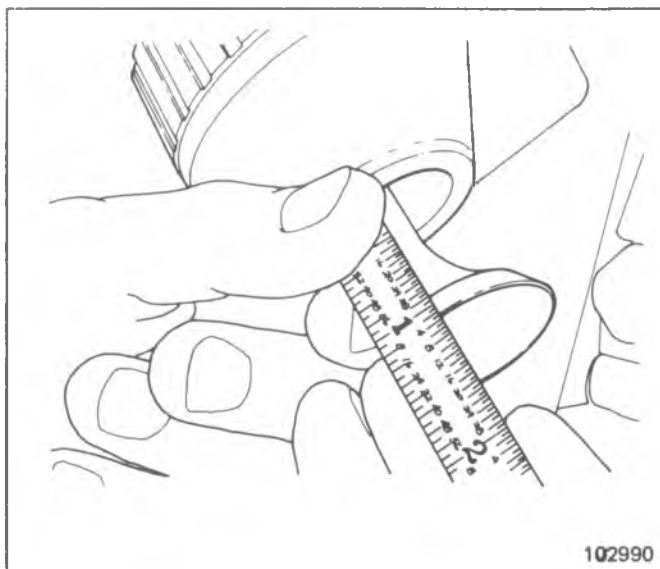

Fig. 6A7-14--Measuring Valve Head

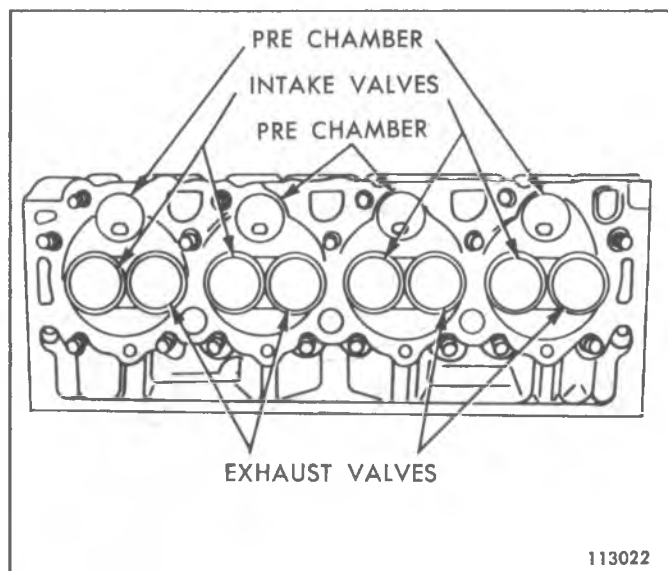

Fig. 6A7-15--Valve Location

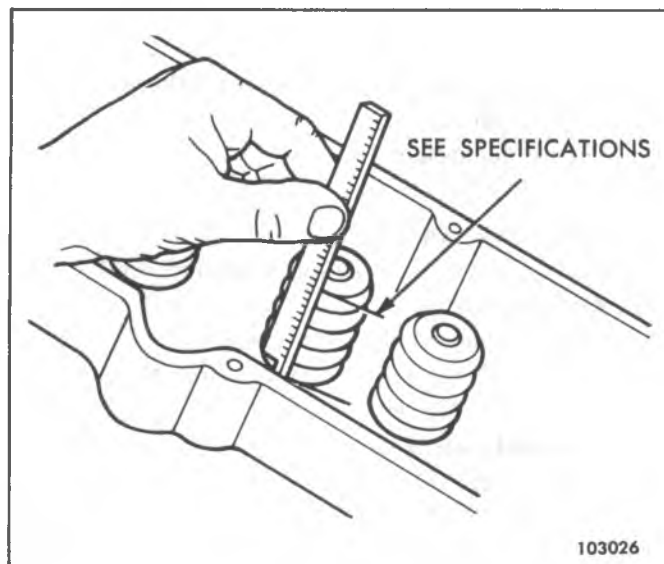

Fig. 6A7-16--Installed Height

### Assembly

1. Insert a valve in the proper port.
2. Assemble the valve spring and related parts as follows:
  - a. Install valve spring shim on valve spring seat then install a new valve stem oil seal.
  - b. Set the valve spring (with damper); and valve cap in place.
  - c. Compress the spring with Tool J-8062.
  - d. Install the valve locks and release the compressor tool, making sure the locks seat properly in the groove of the valve stem. Grease may be used to hold the locks in place while releasing the compressor tool.
3. Install the remaining valves.
4. Check the installed height of the valve springs, using a narrow thin scale. A cutaway scale will help (fig. 6A7-16). Measure from the top of the shim or the spring seat to the top of the valve spring or valve spring shield. If

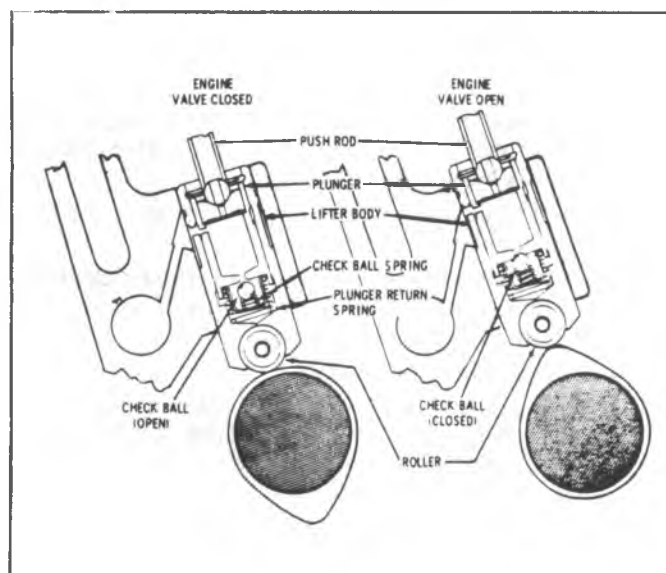

Fig. 6A7-17--Valve Lifter-Cutaway View

this is found to exceed the specified height, install a valve spring seat shim approximately 1/16" (1.6mm) thick. At no time should the spring be shimmed to give an installed height under the minimum specified.

5. Install pre-chamber, if removed. The pre-chamber can only be installed in one position. Use a 1-1/4" socket to reinstall pre-chamber and install in cylinder head. The pre-chamber should be flush .002" above the face of the head.

### Installation (All Models)

All gasket surfaces (especially cylinder head gasket surfaces) to be entirely free of dirt, sand, and foreign matter directly before and during assembly.

Head gaskets are a special composition gasket that must be used **WITHOUT** a sealer.

No additional sealer can be used when installing the head gaskets as the passage surfaces are sealed when the gaskets are made, using a newly developed method and material. This sealer is accurately printed on the surface of the gasket in the exact quantity required and provides the desired bond between the head and the block. Applying additional sealer would only result in the possibility of leakage.

1. Place the gasket over the dowel pins. Left rear cylinder head bolt must be installed into head prior to installation.
2. Carefully guide the cylinder head into place.
3. Coat threads of cylinder head bolts with sealing compound 1052080 or equivalent, and install bolts finger tight.
4. Tighten each cylinder bolt a little at a time in the sequence shown until the specified torque is met 140 N·m (100 ft. lbs.)
5. For remainder of installation reverse removal procedures.

### VALVE LIFTERS (Fig. 6A7-17)

Roller hydraulic lifters are used to reduce the amount of friction between the valve lifter and the camshaft lobe. Guides keep the lifters from rotating on the camshaft lobes.

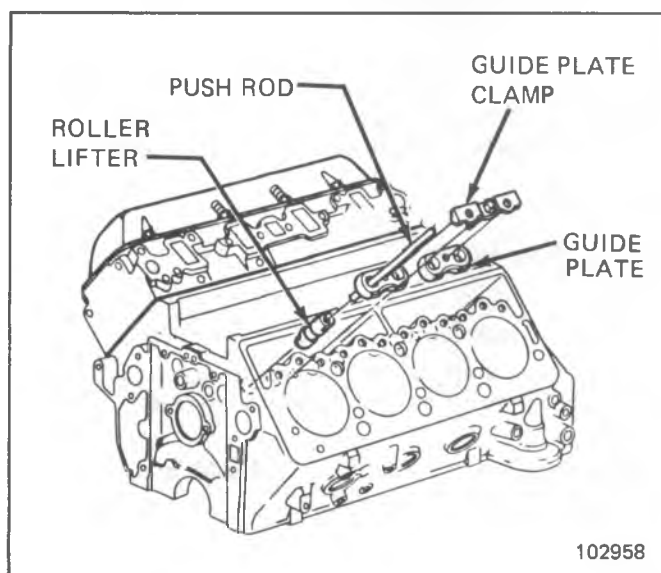

Fig. 6A7-18--Valve Lifter Removal

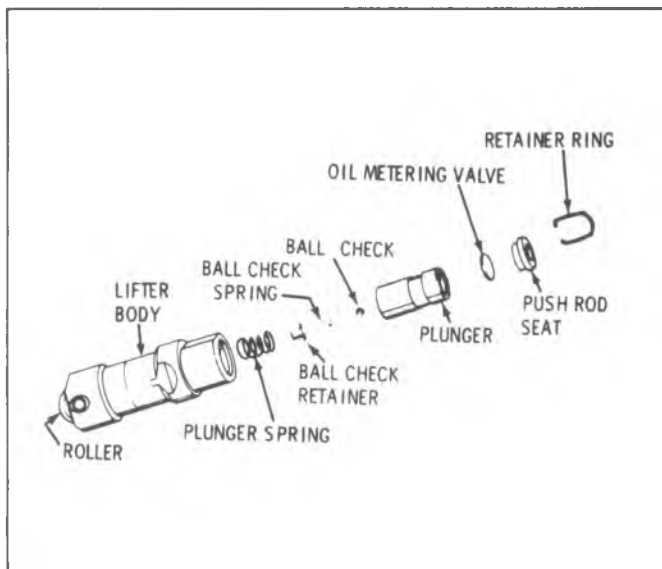

Fig. 6A7-19--Valve Lifter-Exploded View

### Operation

Oil is supplied to the lifter through a hole in the side of the lifter body which indexes with a groove and hole in the lifter plunger. Oil is then metered past the oil metering valve in the lifter, through the push-rods to the rocker arms.

When the lifter begins to roll up the cam lobe, the check valve disc is held against its seat in the plunger by the check valve disc spring which traps the oil in the base of the lifter body below the plunger. The plunger and lifter body then raise as a unit, pushing up the push-rod to open the valve. The force of the valve spring which is exerted on the plunger through the rocker arm and push-rod causes a slight amount of leakage between the plunger and lifter body. This "leak-down" allows a slow escape of trapped oil in the base of the lifter body. As the lifter rides down the other side of the cam lobe and reaches the base circle or "valve closed" position, the plunger spring quickly moves the plunger back (up) to its original position. This movement causes the check valve disc to open against the check valve disc spring and oil from within the plunger is drawn into the base of the lifter. This restores the lifter to zero lash.

Valve lifters and push rods should be kept in order so they can be re-installed in their original position. The push rods must be installed with painted end up. This is necessary as the premium ball is located on the upper end only.

### CK Truck

#### Removal (6A7-18)

1. Remove rocker arm covers as previously outlined.
2. Remove rocker arms as previously outlined.
3. Remove guide clamps and guide plates. It may be necessary to use mechanical fingers to remove the guide plates.
4. Remove lifters using Tool J-29834 and a magnet through access

### G Van

#### Removal

1. Remove cylinder head as previously outlined.
2. Remove guide clamp.
3. Remove guide plate.
4. Remove lifters, holes in cylinder head.

#### Disassembly (Fig. 6A7-19)

1. Remove the retainer ring with a small screwdriver.
2. Remove push-rod seat and oil metering valve.
3. Remove plunger and plunger spring.
4. Remove check valve retainer from plunger, then remove valve and spring.

#### Cleaning and Inspection

After lifters are disassembled, all parts should be cleaned in clean solvent. A small particle of foreign material under the check valve will cause malfunctioning of the lifter. Close inspection should be made for nicks, burrs or scoring of parts. If either the roller body or plunger is defective, replace with a new lifter assembly.

Whenever lifters are removed, check as follows:

1. Roller should rotate freely, but without excessive play.
2. Check for missing or broken needle bearing.
3. Roller should be free of pits or roughness. If present, check camshaft for similar condition. If pits or roughness are evident, replace lifter and camshaft.

#### Assembly

1. Coat all lifter parts with a light coating of clean engine oil.
2. Assemble valve disc spring and retainer into plunger. Make sure retainer flange is pressed tight against bottom of recess in plunger.
3. Install plunger spring over check retainer.
4. Hold plunger with spring up and insert into lifter body. Hold plunger vertically to prevent cocking spring.
5. Install oil metering valve and push rod seat into lifter and install retaining ring.

### CK Truck, G Van

#### Installation

Prime new lifters by working lifter plunger while submerged in new kerosene or diesel fuel. Lifter could be damaged if dry when starting engine.

Coat the roller and bearings of lifter with 1052365 lubricant or equivalent.

1. Install lifters into original position in cylinder block. On CK Truck, use a rigid mechanic's wire or welding rod. Fabricate a lifter installing tool.
2. Install valve lifter guide plate.
3. Install guide plate clamp. Crankshaft must be manually rotated 720° after assembly of lifter guide plate clamp to insure free movement of lifters in guide plates.
4. On G Van, install cylinder head as previously outlined.



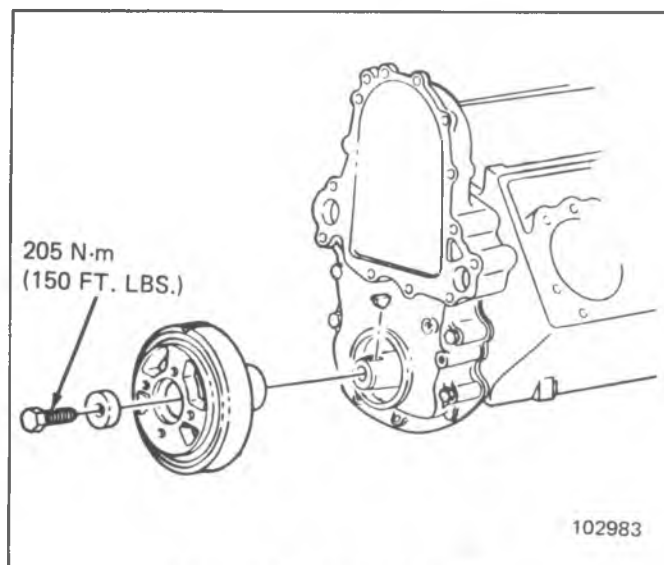

Fig. 6A7-20--Torsional Damper

## CRANKSHAFT PULLEY

### CK Truck

#### Removal

1. Disconnect batteries.
2. Remove generator belt.
3. Remove power steering belt.
4. Remove A/C belt if equipped.
5. Remove pulley.

#### Installation

1. Install pulley.
2. Install belt(s). Adjust belts. See Cooling Section.

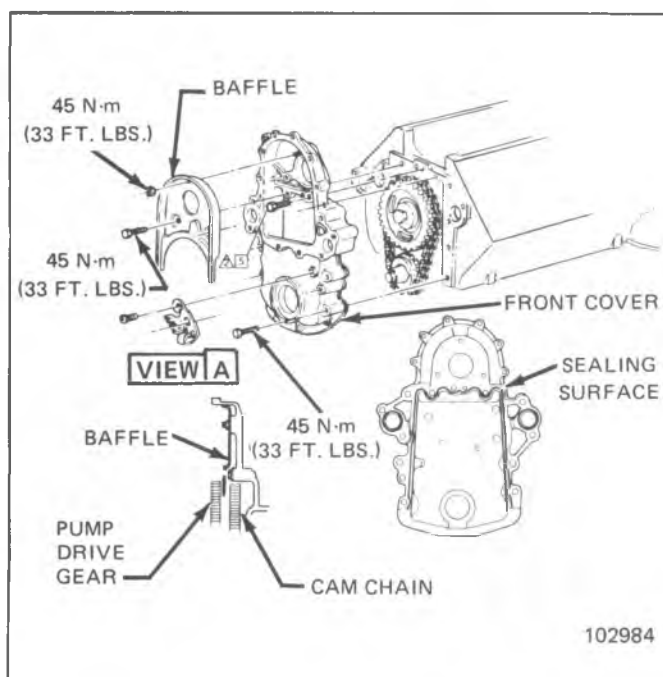

Fig. 6A7-21--Front Cover

## G-Van

#### Removal

1. Disconnect batteries.
2. Remove upper fan shroud.
3. Remove generator belt.
4. Remove power steering belt.
5. If equipped with A/C, remove A/C belt.
6. Raise vehicle.
7. Remove crankshaft pulley.

#### Installation

1. Install pulley.
2. Install belts. Adjust belts. See Cooling Section.
3. Install upper fan shroud.

## TORSIONAL DAMPER (FIG. 6A7-20)

### CK Truck, G Van

#### Removal

1. Disconnect batteries.
2. Remove crank pulley as previously outlined.
3. Remove torsional damper using tool J-23523 and suitable pilot or pilot J-29788.

#### Installation

1. Install damper using a mallet. Assemble key parallel to crankcase. Tap damper far enough on crankshaft so attaching bolt can be installed. Torque bolt to specification.
2. Install crank pulley as outlined.
3. Install belt(s). Adjust belts. See Cooling Section.

## FRONT COVER (Fig. 6A7-21)

### CK Truck, G Van

#### Removal

1. Drain engine block.
2. Remove water pump as outlined in Cooling Section.

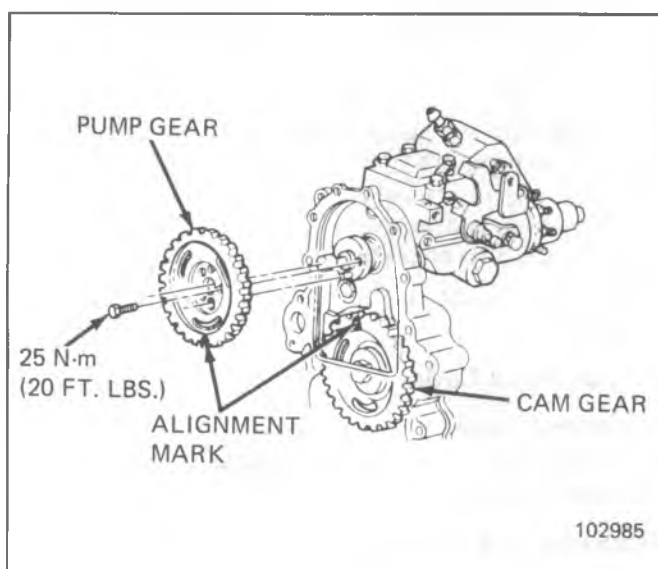

Fig. 6A7-22--Gear Alignment



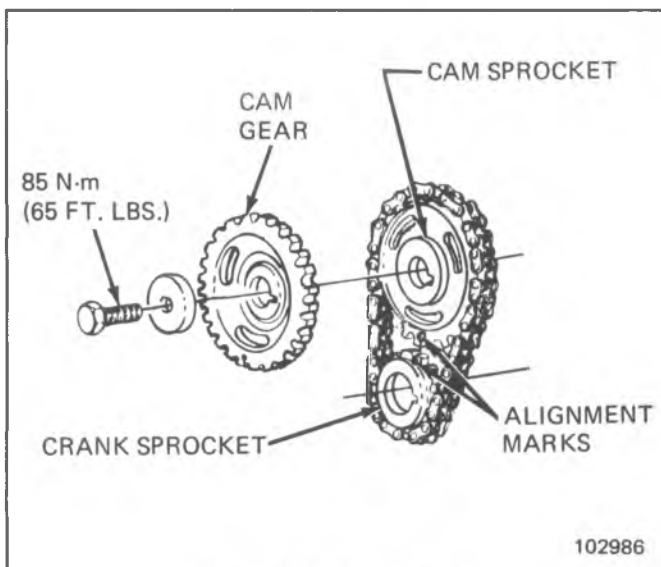

Fig. 6A7-23--Timing Chain

3. Rotate engine and align marks on pump gear and camshaft gear (Fig. 6A7-22).
4. Scribe a mark aligning injection pump flange and front cover.
5. Remove crank pulley as previously outlined.
6. Remove torsional damper as previously outlined.
7. Remove front cover to oil pan bolts (4).
8. Remove fuel return line clips (2).
9. Remove injection pump driven gear.
10. Remove injection pump retaining nuts from front cover.
11. Remove baffle.
12. Remove remaining cover bolts.
13. Remove front cover.

**Installation**

1. With sealing surfaces cleaned place a 2mm (3/32") bead of sealant #1052357 or equivalent as shown in figure 6A7-21. Apply R.T.V. sealer #1052734 to bottom portion of front cover which attaches to oil pan.
2. Install front cover.
3. Install baffle.
4. Install injection pump making sure scribe marks on injection pump and front cover are aligned.
5. Install injection pump driven gear making sure marks on camgear and pump gear are aligned. Be sure dowel pin and 3 holes on pump flange are aligned.
6. For remainder of installation reverse removal procedures.

**Oil Seal (Front Cover)****Replacement (Cover Removed)**

1. With cover removed, pry oil seal out of cover.
2. Install new seal using tool J-22102.

**Replacement (Cover Installed)**

1. With torsional damper removed, pry seal out of cover from the front with a large screwdriver. Be careful not to damage the surface on the crankshaft.

2. Install new seal using tool J-22102.
3. Install torsional damper as outlined.

**TIMING CHAIN (Fig. 6A7-23)****CK Truck, G Van****Removal**

1. Remove front cover as previously outlined.
2. Remove bolt and washer attaching camshaft gear.
3. Remove injection pump gear.
4. Remove cam sprocket, chain, and crank sprocket.

**Installation**

1. Install cam sprocket, lubricate chain and crank sprocket together and align timing marks on sprockets as shown in figure 6A7-23.
2. Rotate crankshaft 360° so that camshaft gear and injection pump gear aligned as shown in Figure 6A7-22.
3. Install front cover as previously outlined. Any time the timing chain, gears or sprockets are replaced it will be necessary to retune the engine. Refer to 6.2 Diesel Fuel Injection Section for injection pump timing procedure.

**CAMSHAFT (FIG. 6A7-24)****CK Truck****Removal**

1. Disconnect batteries.
2. Raise vehicle.
3. Drain radiator and block.
4. Disconnect exhaust pipe at exhaust manifolds.
5. Remove fan shroud attaching bolts.
6. Lower vehicle.
7. Remove fan shroud attaching bolts.
8. Remove radiator as described in the Cooling Section.
9. Remove fan.
10. Remove vacuum pump.
11. Remove intake manifold as previously outlined.
12. Remove injection pump lines at pump and nozzles as outlined in 6.2 Diesel Fuel Injection Section. Cap injection nozzles, to prevent dirt from entering fuel. (Tag injection lines for reinstallation). Refer to 6.2 Diesel Fuel Injection section for removal sequence.

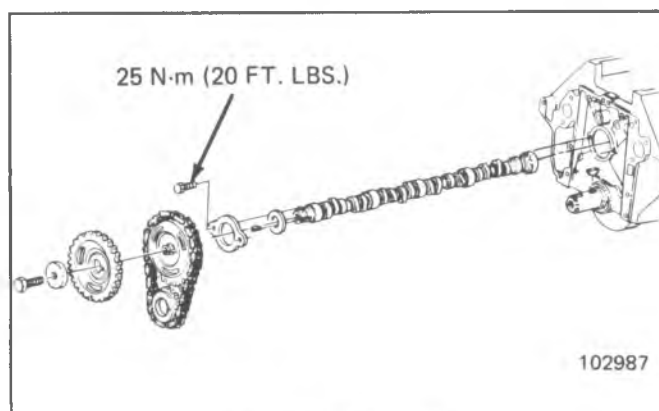

Fig. 6A7-24--Camshaft

13. Remove water pump as outlined in Cooling Section.
14. Remove injection pump gear.
15. Scribe a mark on front cover aligning the line on injection pump flange to the front cover.
16. Remove injection pump from cover.
17. Remove power steering pump and generator and lay aside.
18. If equipped with A/C remove compressor and lay aside.
19. Remove rocker arm covers as previously outlined.
20. Remove rocker arm shaft assembly and push rods. Place parts in a rack so they may be reinstalled in the same location.
21. Remove thermostat housing/crossover from cylinder heads.
22. Remove cylinder head as previously outlined with exhaust manifolds attached.
23. Remove valve lifter clamps, guide plates and valve lifters. Place parts in a rack so they may be reinstalled in the same location.
24. Remove front cover as previously outlined.
25. Remove timing chain as previously outlined.
26. Remove fuel pump.
27. Remove cam retainer plate.
28. If equipped with A/C remove A/C condensor mounting bolts, and with the aid of an assistant, lift condensor.
29. Remove camshaft.

## G Van

### Removal

1. Disconnect batteries.
2. Remove headlight bezels.
3. Remove grille.
4. Remove bumper.
5. Remove lower valence panel.
6. Remove hood latch.
7. Remove coolant recovery bottle.
8. Remove upper tie bar.
9. If equipped with A/C, disconnect lines.
10. Remove condenser.
11. Disconnect low coolant wire.
12. Disconnect engine oil cooler lines at radiator.
13. With automatic transission, disconnect transmission cooler lines at radiator.
14. Disconnect lower radiator hoses at radiator.
15. Disconnect upper radiator hoses at radiator.
16. Remove radiator.
17. Remove fan assembly.
18. Remove cylinder heads as previously outlined.
19. Remove generator lower bracket.
20. Remove water pump and crank pulleys.
21. Remove torsional damper as previously outlined.
22. Remove timing cover plate and water pump.
23. Rotate crankshaft and align timing marks.
24. Remove injection pump driven gear.
25. Remove inner baffle.
26. Align injection pump and front cover by scribing a line across pump flange and front cover.
27. Remove front cover.
28. Remove fuel pump.
29. Remove lifters.
30. Remove injection pump drive gear, timing chain and crankshaft gear.
31. Remove cam retainer plate.
32. Remove camshaft.

## CK Truck, G Van

### Installation

Whenever a new camshaft is installed, replacement of all valve lifters, oil filter, and new oil is recommended to insure durability of the camshaft lobes and lifters. Whenever a new camshaft is installed coat camshaft lobes with "Molycote" or its equivalent.

1. Lubricate camshaft journals with engine oil and install camshaft.
2. Install retainer plate 25 N·m (20 ft. lbs.).
3. Install fuel pump.
4. Install timing chain as previously outlined.
5. Install front cover as previously outlined.
6. Install valve lifters, guide plates and clamps, rotate crankshaft as outlined in valve lifter installation to insure valve lifters are free to travel.
7. Install cylinder head as previously outlined.
8. Install rocker arm shaft assembly and push rods as outlined. Care must be taken to insure push rods are installed properly.
9. Install rocker arm covers.
10. Install injection pump to front cover, making sure lines on pump and scribe line on front cover are aligned.
11. Install injection pump driven gear, making sure gears are aligned. Any time the timing chain, gears, or sprockets are replaced, it will be necessary to retime the engine (refer to 6.2 Diesel Fuel Injection Section for injection pump timing procedure).
12. Install water pump as outlined in Cooling Section.
13. Install injection lines as outlined in 6.2 Diesel Fuel Injection Section.
14. Install generator, power steering and A/C.
15. Install crank pulley.
16. Install fan.
17. Install drive belts and adjust as necessary. Refer to Cooling Section.
18. Install A/C condenser.
19. Install fan shroud (CK Truck).
20. Install radiator, and fill with coolant. On G Van, install coolant recovery bottle.
21. Connect necessary wires and hoses.
22. Raise vehicle.
23. Connect exhaust pipes to exhaust manifold.
24. Lower vehicle.
25. Install vacuum pump (CK Truck).

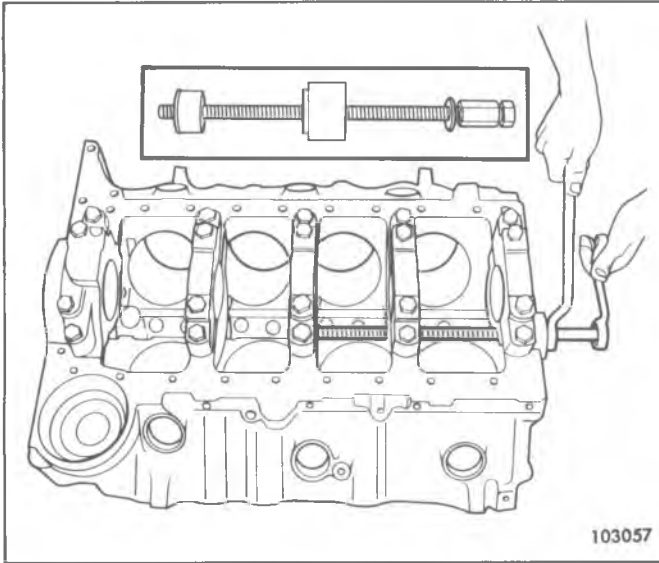

Fig. 6A7-25--Removing Camshaft Bearings

26. Connect secondary fuel filter lines (with adapter).
27. Install cylinder head covers J-29664-1.
28. Connect battery.
29. Start engine and check for leaks.
30. Stop engine.
31. Remove protective covers.
32. Loosen vacuum pump hold down and disconnect secondary filter (with adapter) from fuel lines (CK Truck).
33. Install intake manifold as previously outlined.
34. On G Van:
  - Install upper tie bar.
  - Install fan shroud.
  - Install hood latch.
  - Install lower valence panel.
  - Install bumper.
  - Install grille.
  - Install headlight bezels.

## CAMSHAFT BEARINGS

### CK Truck, G Van

#### Removal

Camshaft bearings can be replaced while engine is disassembled for overhaul.

1. With camshaft and crankshaft removed, drive camshaft rear plug from cylinder block.
2. Using Tool J-6098 with nut and thrust washer installed to end of threads, index pilot in camshaft front bearing and install puller screw through pilot.
3. Install remover and installer tool J-6098-11 for #2, 3, 4 bearing with shoulder toward bearing, making sure a sufficient amount of threads are engaged.
4. Using two wrenches, hold puller screw while turning nut. When bearing has been pulled from bore, remove

remover and installer tool and bearing from puller screw (fig. 6A7-25).

5. Remove remaining bearings (except front and rear) in the same manner. It will be necessary to index pilot in camshaft rear bearing to remove the rear intermediate bearing.
6. Assemble remover and installer tool J-6098-11 for #1 and J-6098-12 for #5 bearing on driver handle and remove camshaft front and rear bearings by driving towards center of cylinder block (fig. 6A7-26).

#### Installation

The camshaft front and rear bearings should be installed first. These bearings will act as guides for the pilot and center the remaining bearings being pulled into place.

1. Assemble remover and installer tool on driver handle and install camshaft front and rear bearings by driving towards center of cylinder block.
2. Using Tool Set J-6098 with nut then thrust washer installed to end of threads, index pilot in camshaft front bearing and install puller screw through pilot.
3. Index camshaft bearing in bore (with oil hole aligned as outlined below), then install remover and installer tool on puller screw with shoulder toward bearing. Number one through number four cam bearing oil hole must be aligned with oil holes in cam bearing bore. The number five bearing bore is annulus, and cam bearing must be positioned at or near the 6 o'clock position.
4. Using two wrenches, hold puller screw while turning nut. After bearing has been pulled into bore, remove the remover and installer tool from puller screw, and check alignment of oil hole in camshaft bearing.
5. Install remaining bearings in the same manner. It will be necessary to index pilot in the camshaft rear bearing to install the rear intermediate bearing.
6. Coat new rear plug O.D. with #1052080 sealant, or equivalent, and install flush to 1/32" (.80mm) deep.

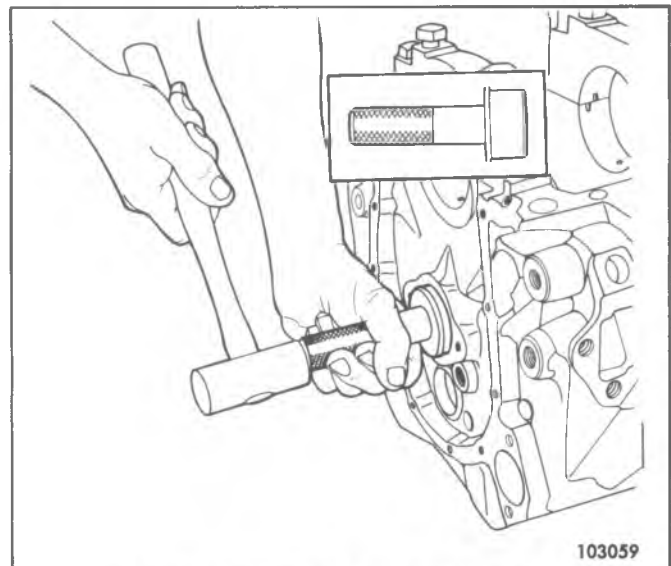

Fig. 6A7-26--Replacing Camshaft Front Bearing

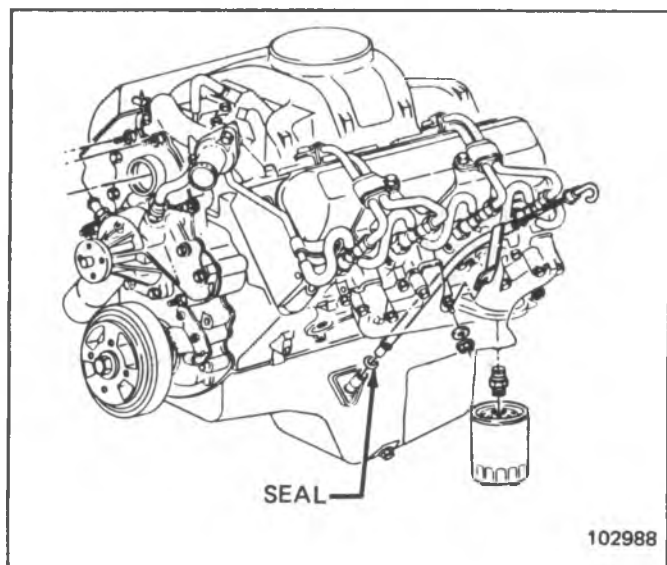

Fig. 6A7-27--Dipstick Tube

**DIPSTICK TUBE (Fig. 6A7-27)****CK Truck****Removal and Installation**

1. Disconnect batteries.
2. Remove attaching bolt at exhaust manifold.
3. Remove dipstick tube.
4. Remove O-ring seal. To install reverse removal procedures.

**G Van****Removal and Installation**

1. Disconnect batteries.
2. Remove engine cover.
3. Remove air cleaner.
4. Disconnect tube forward bracket at thermostat.
5. Disconnect tube at left rocker cover bracket.
6. Raise vehicle.
7. Disconnect exhaust at manifold.
8. Remove exhaust manifold bolts.
9. Remove exhaust manifold.
10. Pull dipstick tube from pan.
11. Lower vehicle.
12. Remove dipstick tube.
13. Remove and replace O-ring seal. To install, reverse removal procedures.

**OIL PAN (Fig. 6A7-28)****CK Truck****Removal**

1. Disconnect batteries.
2. Raise vehicle.
3. Drain oil.
4. Remove transmission dust cover.
5. Remove oil pan bolts.

6. Remove engine mount through bolt (left side).
7. Raise engine.
8. Remove oil pan.

**Installation**

At time of installation, flanges must be free of oil. A 5.0mm bead of 1052734 or equivalent sealer must be applied and sealer must be wet to the touch when bolts are torqued.

1. Check rear seal for cracks.
2. Install oil pan and torque bolts to specifications.
3. Lower engine.
4. Install engine mount through bolt.
5. Install transmission dust cover.
6. Lower vehicle.
7. Refill oil.
8. Connect battery.

**G Van****Removal**

1. Disconnect battery.
2. Remove engine cover.
3. Remove oil dipstick.
4. Remove transmission oil dipstick.
5. Disconnect engine oil dipstick tube at left rocker cover.
6. Disconnect transmission dipstick at bell housing and pull from transmission.
7. Disconnect T.V. cable at injection pump rod and at transmission dipstick tube.
8. Remove upper bellhousing bolt.
9. Remove vacuum pump.
10. Raise vehicle.
11. Remove propshaft.
12. Disconnect speedometer cable at transmission.
13. Disconnect torque converter clutch connector at

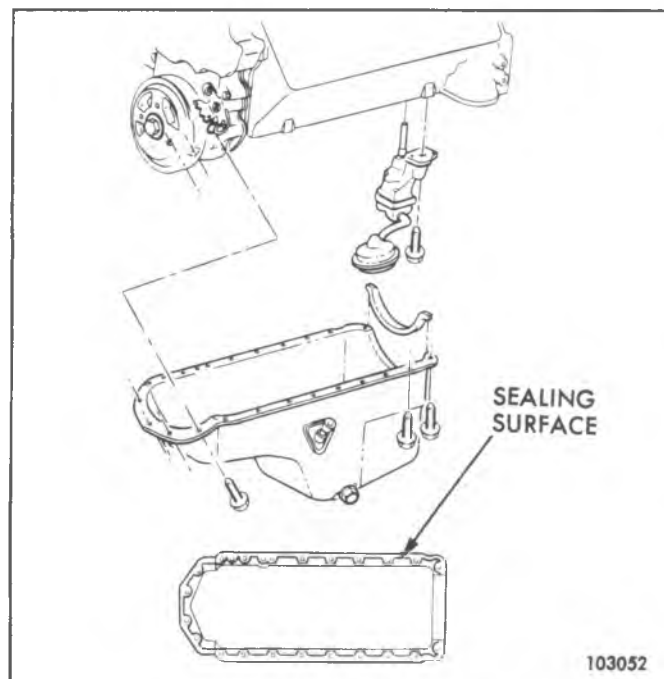

Fig. 6A7-28--Oil Pan

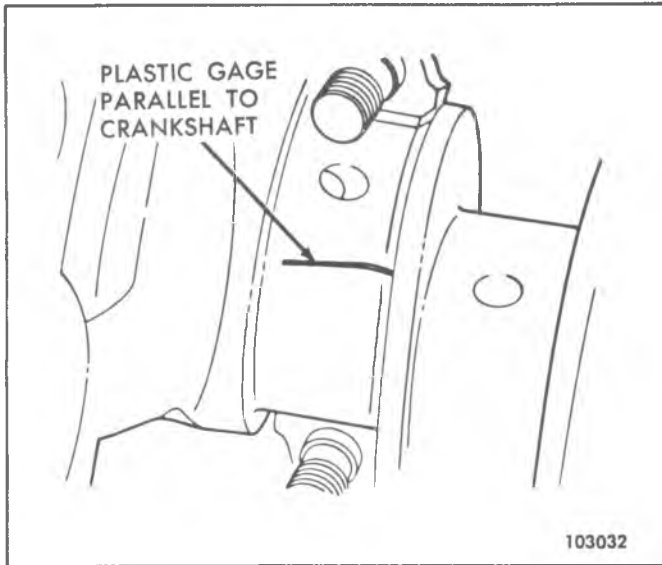

Fig. 6A7-29--Gaging Plastic on Crankpin

transmission.

14. Disconnect shift linkage at transmission.
15. Disconnect transmission cooler lines at transmission.
16. Remove flexplate inspection cover.
17. Remove flexplate to torque converter bolts.
18. Support transmission.
19. Remove transmission mount to crossmember nut.
20. Remove crossmember.
21. Remove bellhousing to cylinder case bolts.
22. Remove transmission assembly.
23. Remove flexplate.
24. Remove dipstick tube from engine oil pan.
25. Drain crankcase.
26. Disconnect engine oil cooler lines at cylinder case.
27. Remove starter.
28. Remove oil pan bolts -- includes disconnecting battery and cooler line clips.
29. Lower pan from cylinder case.
30. It may be necessary to rotate crankshaft so forward throw and Number 1 and 2 journals are up, giving front of pan clearance.
31. Remove oil pump to main cap bolt, disconnect drive shaft and let assembly fall into pan.
32. Remove oil pan.

#### Installation

At time of installation, flanges must be free of oil. A 5.0mm bead of sealer 1052734 or equivalent must be applied and sealer must be wet to the touch when bolts are torqued.

1. Check rear seal for cracks.
2. Install dipstick tube in pan before fully seating oil pan.
3. Inspect oil pump drive shaft bushing, check for cracks, replace if necessary.
4. Lay oil pump assembly into oil pan.
5. Install oil pump to main cap.
6. Install oil pan.

7. Reverse removal procedures for the remainder of installation steps.

## OIL PUMP

### CK Truck, G Van

#### Removal

1. Remove oil pan as previously outlined.
2. Remove pump to rear main bearing cap bolt and remove pump and extension shaft.

#### Disassembly

1. Remove the pump cover attaching screws and the pump cover.
2. Mark gear teeth so they may be reassembled with the same teeth indexing. Remove the idler gear and the drive gear and shaft from the pump body.
3. Remove the pressure regulator valve retaining pin, pressure regulator valve and related parts.

#### Cleaning and Inspection

1. Wash all parts in cleaning solvent and dry with compressed air.
2. Inspect the pump body and cover for cracks or excessive wear.
3. Inspect pump gears for damage or excessive wear. The pump gears and body are not serviced separately. If the pump gears or body are damaged or worn, replacement of the entire oil pump assembly is necessary.
4. Check the drive gear shaft for looseness in the pump body.
5. Inspect inside of pump cover for wear that would permit oil to leak past the ends of the gears.
6. Inspect the pickup screen and pipe assembly for damage to screen, pipe or relief grommet.
7. Check the pressure regulator valve for fit.

#### Assembly

1. Install the pressure regulator valve and related parts.
2. Install the drive gear and shaft in the pump body.
3. Install the idler gear in the pump body with the smooth side of gear towards pump cover opening.
4. Install the pump cover and torque attaching screws to specifications.
5. Turn drive shaft by hand to check for smooth operation.

#### Installation

1. Assemble pump and extension shaft to rear main bearing cap, aligning hex on top end of extension shaft with drive hex on lower end of vacuum pump drive shaft.
2. Install pump to rear bearing cap bolt and torque to specifications.
3. Install oil pan previously outlined.

## CONNECTING ROD BEARINGS

Connecting rod bearings are of the precision insert type and do not utilize shims for adjustment. **DO NOT FILE RODS OR ROD CAPS.** If clearances are found to be excessive a new bearing will be required. Service bearings are

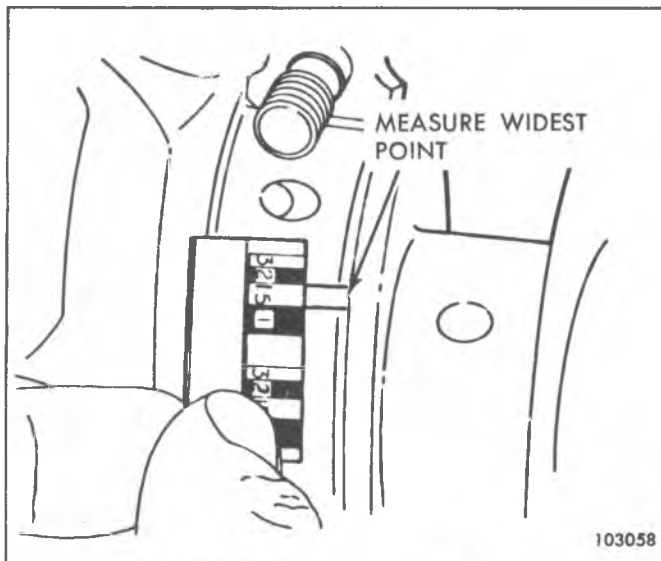

Fig. 6A7-30--Measuring Gaging Plastic

available in standard size and .001". For use with new and used standard size crankshafts.

#### Inspection and Replacement

1. With oil pan and oil pump removed, remove the connecting rod cap and bearing. Before removal of connecting rod cap, mark the side of the rod and cap with the cylinder number to assure matched reassembly of rod and cap.
2. Inspect the bearing for evidence of wear or damage. (Bearings showing the above should not be installed.)
3. Wipe both upper and lower bearing shells and crankpin clean of oil.
4. Measure the crankpin for out-of-round or taper with a micrometer. If not within specifications replace the crankshaft. If within specifications and a new bearing is to be installed, measure the maximum diameter of the crankpin to determine new bearing size required.

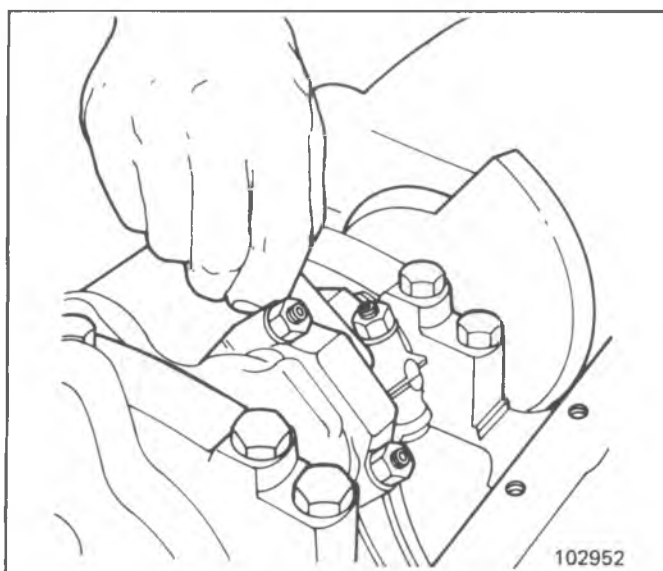

Fig. 6A7-31--Connecting Rod Side Clearance

5. If within specifications measure new or used bearing clearances with Plastigage or its equivalent. If a bearing is being fitted to an out-of-round crankpin, be sure to fit to the maximum diameter of the crankpin. If the bearing is fitted to the minimum diameter and the crankpin is out-of-round .001" interference between the bearing and crankpin will result in rapid bearing failure.
  - a. Place a piece of gaging plastic, the length of the bearing (parallel to the crankshaft), on the crankpin or bearing surface (fig. 6A7-29). Plastic gage should be positioned in the middle of upper or lower bearing shell. (Bearings are eccentric and false readings could occur if placed elsewhere).
  - b. Install the bearing in the connecting rod and cap.
  - c. Install the bearing cap and evenly torque nuts to specifications. Do not turn the crankshaft with the gaging plastic installed.
  - d. Remove the bearing cap and using the scale on the gaging plastic envelope, measure the gaging plastic width at the widest point (Fig. 6A7-30).
6. If the clearance exceeds specification (.0018" - .0039"), select a new, correct size, bearing and remeasure the clearance. Be sure to check what size bearing is being removed in order to determine proper replacement size bearing. If the crankpin is already at maximum undersize, replace crankshaft.
7. Coat the bearing surface with oil, install the rod cap and torque nuts to specifications.
8. When all connecting rod bearings have been installed tap each rod lightly (parallel to the crankpin) to make sure they have clearance.
9. Measure all connecting rod side clearances (see specifications) between connecting rod caps (Fig. 6A7-31).

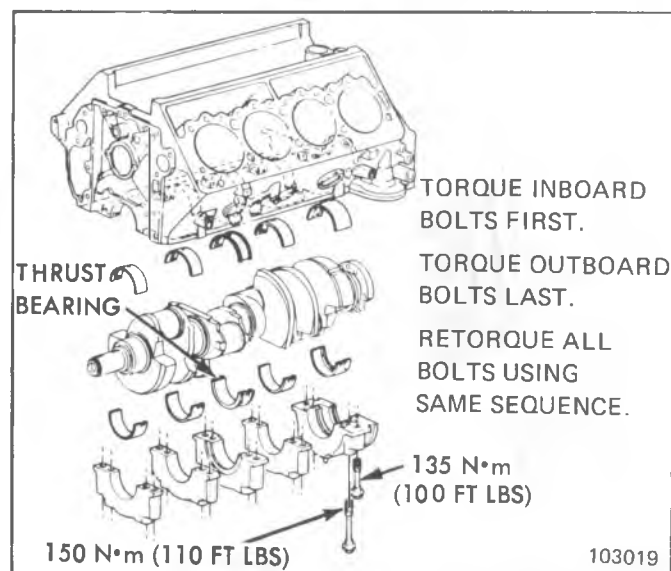

Fig. 6A7-32--Main Bearings

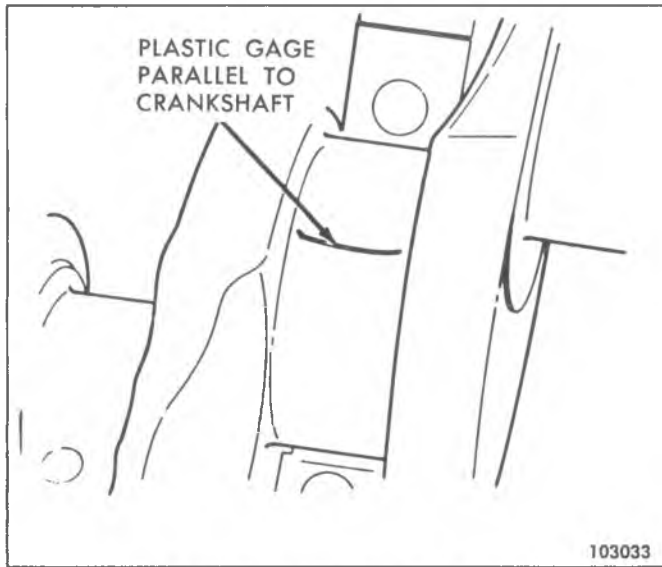

Fig. 6A7-33--Gaging Plastic On Journal

### MAIN BEARINGS (Fig. 6A7-32)

Main bearings are of the precision insert type and do not utilize shims for adjustment. If clearances are found to be excessive, a new bearing, both upper and lower halves, will be required. Service bearings are available in standard size and undersize.

Selective fitting of both rod and main bearing inserts is necessary in production in order to obtain close tolerances. For this reason you may find one half of a standard insert with one half of a .001" undersize insert which will decrease the clearance .0005" from using a full standard bearing.

### Inspection

In general, the lower half of the bearing (except #1 bearing) shows a greater wear and the most distress from fatigue. If upon inspection the lower half is suitable for use, it can be assumed that the upper half is also satisfactory. If the lower half shows evidence of wear or damage, both upper and lower halves should be replaced.

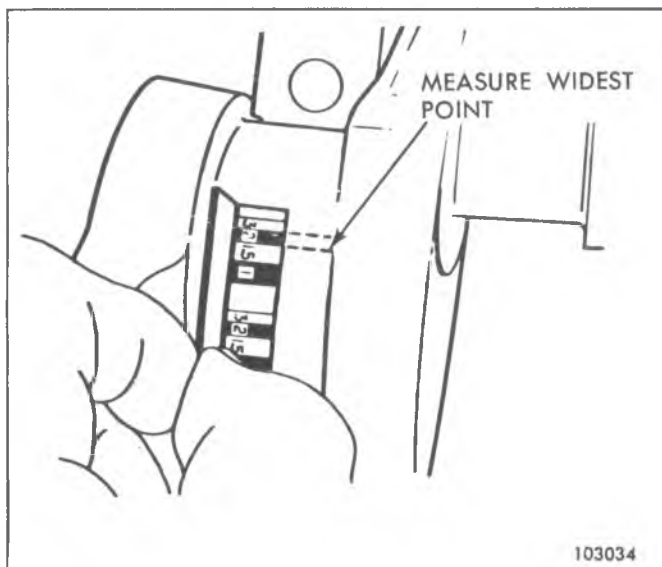

Fig. 6A7-34--Measuring Gaging Plastic

Never replace one half without replacing the other half.

### Checking Clearance

To obtain the most accurate results with "Plastigage" (or its equivalent) a wax-like plastic material which will compress evenly between the bearing and journal surfaces without damaging either surface, certain precautions should be observed.

If the engine is out of the vehicle and upside down, the crankshaft will rest on the upper bearings and the total clearance can be measured between the lower bearing and journal. If the engine is to remain in the vehicle, the crankshaft must be supported upward to remove the clearance from the upper bearing. The total clearance can then be measured between the lower bearing and journal.

To assure the proper seating of the crankshaft, all bearing cap bolts should be at their specified torque. In addition, preparatory to checking fit of bearings, the surface of the crankshaft journal and bearing should be wiped clean of oil.

1. With the oil pan and oil pump removed, and starting with the rear main bearing, remove bearing cap and wipe oil from journal and bearing cap.
2. Place a piece of gaging plastic the full width of the bearing (parallel to the crankshaft) on the journal (fig. 6A7-33). Do not rotate the crankshaft while the gaging plastic is between the bearing and journal.
3. Install the bearing cap and evenly torque the retaining bolts to specifications. Bearing cap **MUST** be torqued to specifications in order to assure proper reading. Variations in torque affect the compression of the plastic gage.
4. Remove bearing cap. The flattened gaging plastic will be found adhering to either the bearing shell or journal.
5. On the edge of gaging plastic envelope there is a graduated scale which is correlated in thousandths of an inch. Without removing the gaging plastic, measure its compressed width (at the widest point) with the graduations on the gaging plastic envelope (fig. 6A7-34). Normally main bearing journals wear

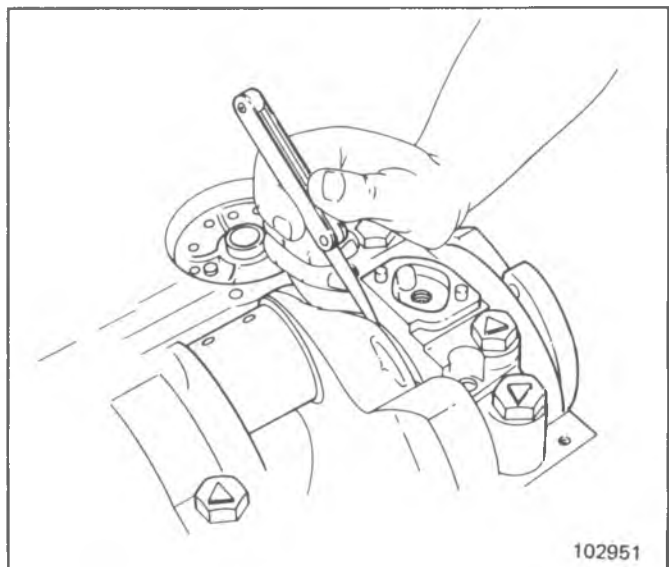

Fig. 6A7-35--Crankshaft End Play



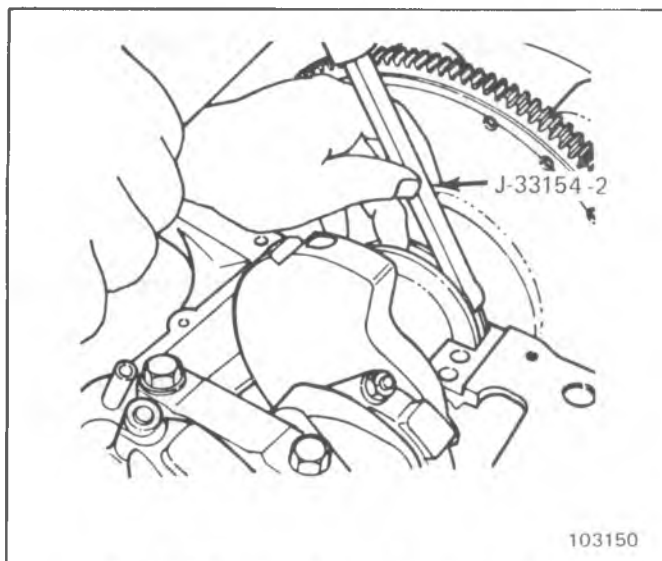

Fig. 6A7-36--Using Parking Tool Upper Half

evenly and are not out-of-round. However, if a bearing is being fitted to an out-of-round (.001" max.), be sure to fit to the maximum diameter of the journal. If the bearing is fitted to the minimum diameter and the journal is out-of-round .001", interference between the bearing and journal will result in rapid bearing failure. If the flattened gaging plastic tapers toward the middle or ends, there is a difference in clearance indicating taper, low spot or other irregularity of the bearing or journal. Be sure to measure the journal with a micrometer if the flattened gaging plastic indicates more than .001" difference.

6. If the bearing clearance is within specifications #1, 2, 3, 4 (.0018"-.0033") and #5 (.0022" - .0037"), the bearing insert is satisfactory. If the clearance is not within specifications, replace the insert. Always replace both upper and lower inserts as a unit. If a new bearing cap is being installed and clearances are less than .001", inspect for burrs or nicks; if none required, then install shims as required.
7. A standard, .001" or .002" undersize bearing may produce the proper clearance. If not, it will be necessary to regrind the crankshaft journal for use with the next undersize bearing. After selecting new bearing, recheck clearance.
8. Proceed to the next bearing. After all bearings have been checked rotate the crankshaft to see that there is no excessive drag. When checking #1 main bearing, loosen accessory drive belts so as to prevent tapered reading with plastic gage.
9. Measure crankshaft end play (see specifications) by forcing the crankshaft to the extreme front position. Measure at the front end of the rear main bearing with a feeler gage (fig. 6A7-35).
10. Install a new rear main bearing oil seal in the cylinder block and main bearing cap.

#### Replacement

Main bearings may be replaced with or without removing the crankshaft.

#### With Crankshaft Removal

1. Remove and inspect the crankshaft.
2. Remove the main bearings from the cylinder block and main bearing caps.
3. Coat bearing surfaces of new, correct size, mainbearings with oil and install in the cylinder block and main bearing caps.
4. Install the crankshaft.

#### Without Crankshaft Removal

1. With oil pan, oil pump and glow plugs removed, remove cap on main bearing requiring replacement and remove bearing from cap.
2. Install a main bearing removing and installing tool in oil hole in crankshaft journal. If such a tool is not available, a cotter pin may be bent as required to do the job.
3. Rotate the crankshaft clockwise as viewed from the front of engine. This will roll upper bearing out of block.
4. Oil new selected size upper bearing and insert plain (unnotched) end between crankshaft and indented or notched side of block. Rotate the bearing into place and remove tool from oil hole in crankshaft journal.
5. Oil new lower bearing and install in bearing cap.
6. Install main bearing cap.
7. Torque all main bearing caps EXCEPT THE REAR MAIN CAP to specifications. Torque rear main bearing cap to 10-12 lb. ft. (14-16 N·m) then tap end of crankshaft, first rearward then forward with a lead hammer. This will line up rear main bearing and crankshaft thrust surfaces. Retorque all main bearing caps to specifications.

#### OIL SEAL-REAR MAIN

##### Repair

1. Remove oil pan and oil pump as previously outlined.
2. Remove rear main bearing cap.
3. Use packing tool J-33154-2 and gently drive upper

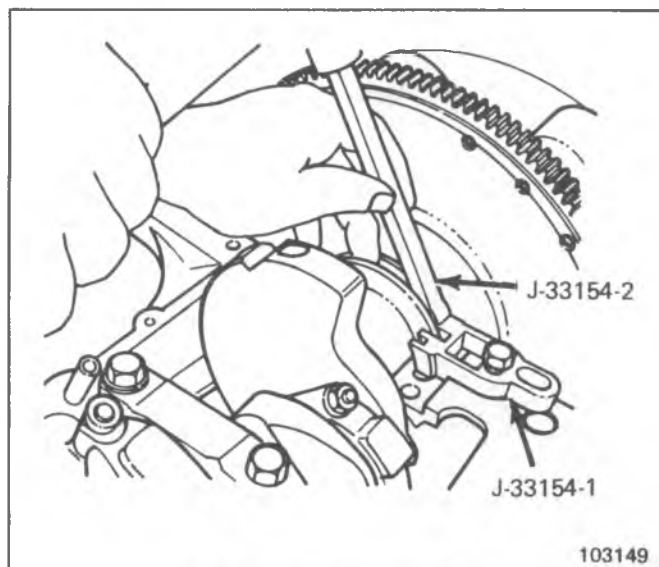

Fig. 6A7-37--Using Guide Tool



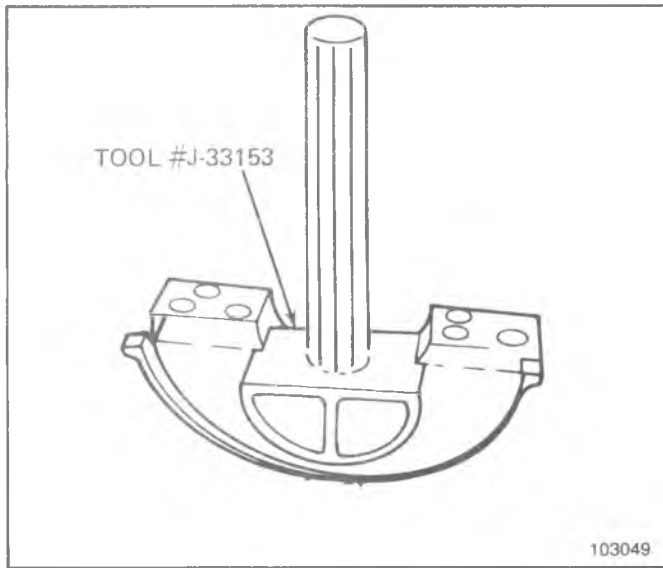

Fig. 6A7-38--Installing New Seal Lower Half

seal into groove approximately 1/4". Do this on both sides (Figure 6A7-36).

4. Measure the amount the seal was driven up on one side and add 1/16", using a sharp tool cut that length from the old seal removed from the rear main bearing cap. Repeat the procedure for the other side. Use the rear main bearing cap as a holding fixture when cutting the seal.
5. Install guide tool (J-33154-1) onto cylinder block (Figure 6A7-37).
6. Using packing tool, work the short pieces cut in Step 4 onto the guide tool and then pack into cylinder block. The guide tool and packing tool have been machined to provide a built-in stop. Use this procedure for both sides.
7. It may help to use oil on the short pieces of the rope seal when packing into the cylinder block.
8. Apply Loctite 496 or equivalent and install a new rope seal in the rear main bearing cap.
9. Using tool J-33153 as shown in Figure 6A7-38 and cut ends of seal flush with cup.
10. Place a piece of plastic gaging material on the rear main journal.
11. Install the rear main bearing cap and torque to 95 N·m (70 ft. lbs.).
12. Remove the rear cap and check the plastic gage for bearing clearance. If out of specification, recheck the ends of the seal for fraying that may be preventing the cap from fully seating. Correct as necessary.
13. Clean plastic gage from journal and bearing.
14. Apply a thin film of anaerobic sealant, #1052357 or equivalent to the cap. Keep sealant off the seal and bearing.
15. Just prior to assembly, apply a light coat of engine oil on crankshaft surface that will contact seal.
16. Install rear main bearing cap. Torque bolts torque bolts to specifications.

17. Install oil pump and oil pan as previously outlined.

## CONNECTING ROD AND PISTON ASSEMBLIES

### Removal

1. Remove oil pan, oil pump and cylinder head as previously outlined.
2. For the cylinder being serviced, turn crankshaft until piston is at the bottom of the stroke. Place a cloth on top of the piston.
3. Use a ridge reamer to remove any ridge and/or deposits from the upper end of the cylinder bore.
4. Remove rod bearing cap and bearing.
5. Install guide hose over threads of rod bolts. This is to prevent damage to bearing journal and rod bolt threads.
6. Remove rod and piston assembly through the top of the cylinder bore.

### Disassembly

1. Remove connecting rod bearings from connecting rods and caps. If bearings are being reused, place them in a rack so they may be reinstalled in their original rod and cap.
2. Remove piston rings by expanding and sliding them off the pistons.
3. Remove piston pin retaining ring and remove piston pin.

## CYLINDER BLOCK

### Cleaning and Inspection

1. Wash cylinder block thoroughly in cleaning solvent and clean all gasket surfaces.
2. Remove oil gallery plugs and clean all oil passages.
3. Clean and inspect water passages in the cylinder block.
4. Inspect the cylinder block for cracks in the cylinder walls, water jacket, valve lifter bores and main bearing webs.
5. Measure the cylinder walls for taper, out-of-round or excessive ridge at top of ring travel. This should be done with a dial indicator. Set the gage so that the thrust pin must be forced in about 1/4" (6.5mm) to enter gage in cylinder bore. Center gage in cylinder and turn dial to "0". Carefully work gage up and down cylinder to determine taper and turn it to different points around cylinder wall to determine the out-of-round condition. If cylinders were found to exceed specifications, honing or boring will be necessary.

### Conditioning

The performance of the following operation is contingent upon engine condition at time of repair.

If the cylinder block inspection indicated that the block was suitable for continued use except for out-of-round or tapered cylinders, they can be conditioned by honing or boring.

If the cylinders were found to have less than .005" taper or wear, they can be conditioned with a hone and fitted with the high limit standard size piston. A cylinder bore of less than .005" wear or taper may not entirely clean up when fitted to a high limit piston. If it is

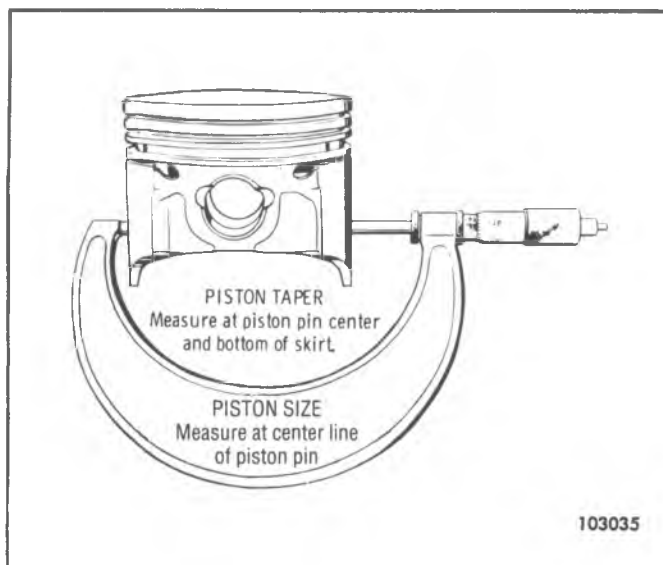

Fig. 6A7-39--Measuring Piston

desired to entirely clean up the bore in these cases, it will be necessary to rebore for an oversize piston. If more than .005" taper or wear, they should be bored and honed to the smallest oversize that will permit complete resurfacing of all cylinders.

When pistons are being fitted and honing is not necessary, cylinder bores may be cleaned with a hot water and detergent wash. After cleaning, the cylinder bores should be swabbed several times with light engine oil and a clean cloth and then wiped with a clean dry cloth.

#### Boring

1. Before using any type boring bar, the top of the cylinder block should be filed off to remove any dirt or burrs. This is very important. If not checked, the boring bar may be tilted which would result in the rebored cylinder wall not being at right angles to the crankshaft.
2. The piston to be fitted should be measured with a micrometer, measuring at the center of the piston skirt and at right angles to the piston pin. The cylinder should be bored to the same diameter as the piston and honed to give the specified clearance.
3. The instructions furnished by the manufacturer of the equipment being used should be carefully followed.

#### Honing

1. When cylinders are to be honed, follow the hone manufacturer's recommendations for the use of the hone and cleaning and lubrication during honing.
2. Occasionally during the honing operation, the cylinder bore should be thoroughly cleaned and the piston selected for the individual cylinder checked for correct fit.
3. When finished honing a cylinder bore to fit a piston, the hone should be moved up and down at a sufficient speed to obtain very fine uniform surface finish marks, in a cross-hatch pattern of approximately 45° to 65° included angle. The finish marks should be clean but

not sharp, free from imbedded particles and torn or folded metal.

4. Permanently mark the piston for the cylinder to which it has been fitted and proceed to hone cylinders and fit the remaining pistons.

**NOTICE:** Handle the pistons with care and do not attempt to force them through the cylinder until the cylinder has been honed to correct size as this type piston can be distorted through careless handling.

5. Thoroughly clean the bores with hot water and detergent. Scrub well with a stiff bristle brush and rinse thoroughly with hot water. It is extremely essential that a good cleaning operation be performed. If any of the abrasive material is allowed to remain in the cylinder bores, it will rapidly wear the new rings and cylinder bores in addition to the bearings lubricated by the contaminated oil, the bores should be swabbed and then wiped with a clean dry cloth. Cylinder should not be cleaned with a kerosene or gasoline. Clean the remainder of the cylinder block to remove the excess material spread during the honing operation.

#### Piston Selection

1. Check USED piston to cylinder bore clearance as follows:
  - a. Measure the "Cylinder Bore Diameter" with a telescope gage 2-1/2" (64mm) from the top of cylinder bore.
  - b. Measure the "Piston Diameter" (at skirt across center line of piston pin).
  - c. Subtract piston diameter from cylinder bore diameter to determine "Piston to Bore Clearance".
2. If used piston is not acceptable, determine if a new piston can fit cylinder bore.
3. If cylinder bore must be reconditioned, measure new piston diameter (across center line of piston pin) then hone cylinder bore to correct clearance.
4. Mark the piston to identify the cylinder for which it was fitted.

#### ROD ASSEMBLY

If a rod is twisted or bent, a new rod must be installed. **NO ATTEMPT SHOULD BE MADE TO STRAIGHTEN CONNECTING RODS.**

#### PISTONS

Clean varnish from piston skirts and pins with a cleaning solvent. **DO NOT WIRE BURSH ANY PART OF THE PISTON.** Clean the ring grooves with a groove cleaner and make sure oil ring holes and slots are clean.

Inspect the piston for cracked ring lands, skirts or pin bosses, wavy or worn ring lands, scuffed or damaged skirts, eroded areas at top of the piston. Replace pistons that are damaged or show signs of excessive wear.

Inspect the grooves for nicks or burrs that might cause the rings to hang up.

Measure piston skirt (across center line of piston pin) and check clearance.

#### PISTON PINS

The piston pin is a free floating piston pin. It is important that the piston and rod pin hole be clean and free

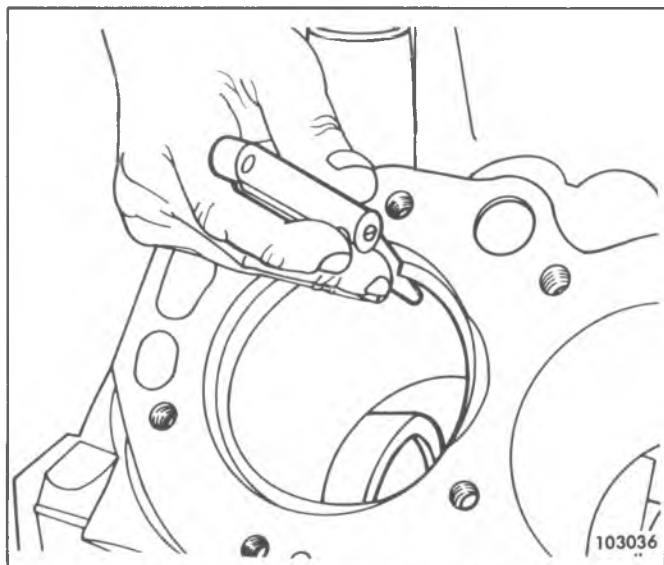

Fig. 6A7-40--Measuring Piston Ring Gap

of oil when checking pin fit. The rod may be installed in the piston with either side facing up.

Whenever the replacement of a piston pin is necessary, remove the ring retaining the pin. Whenever the retaining ring is removed, it must be replaced with a new ring. Using tool J-29134, install piston pin retaining rings that the rings be rotated to make sure they are fully seated in their grooves.

It is very important that after installing the piston pin retaining rings that the rings be rotated to make sure they are fully seated in their grooves.

## RINGS

The pistons have three rings (two compression rings and one oil ring). The oil ring consists of two rails and an expander. Pistons do not have oil drain holes behind the rings.

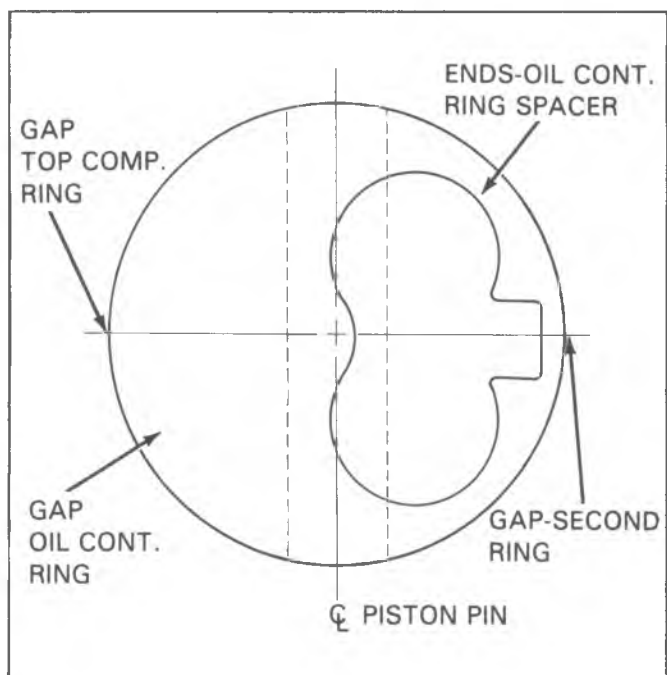

Fig. 6A7-41--Ring Gap Location

## Ring Gap

All compression rings are marked on the upper side of the ring. When installing compression rings, make sure the marked side is toward the top of the piston. The top ring is chrome faced, or treated with molybdenum for maximum life.

1. Select rings comparable in size to the piston being used.
2. Slip the compression ring in the cylinder bore; then press the ring down into the cylinder bore about 1/4" (6.5mm) (above ring travel). Be sure ring is square with cylinder wall.
3. Measure the space or gap between the ends of the ring with a feeler gage (fig. 6A7-40).
4. If the gap between the ends of the ring is below specifications, remove the ring and try another for fit.
5. Fit each compression ring to the cylinder in which it is going to be used.
6. If the pistons have not been cleaned and inspected as previously outlined, do so.
7. Slip the outer surface of the top and second compression ring into the respective piston ring groove and roll the ring entirely around the groove to make sure that the ring is free. If binding occurs at any point, the cause should be determined. If binding is caused by ring groove, correct by dressing with a fine cut file. If the binding is caused by a distorted ring, check a new ring.

## RING INSTALLATION

For service ring specifications and detailed installation instructions, refer to the instructions furnished with the parts package.

## ROD AND PISTON (Fig. 6A7-44)

### Installation

1. Install connecting rod bolt guide hose over rod bolt threads. (Fig. 6A7-43).
2. Lightly coat pistons, rings and cylinder walls with light engine oil. Depression on top of piston to be

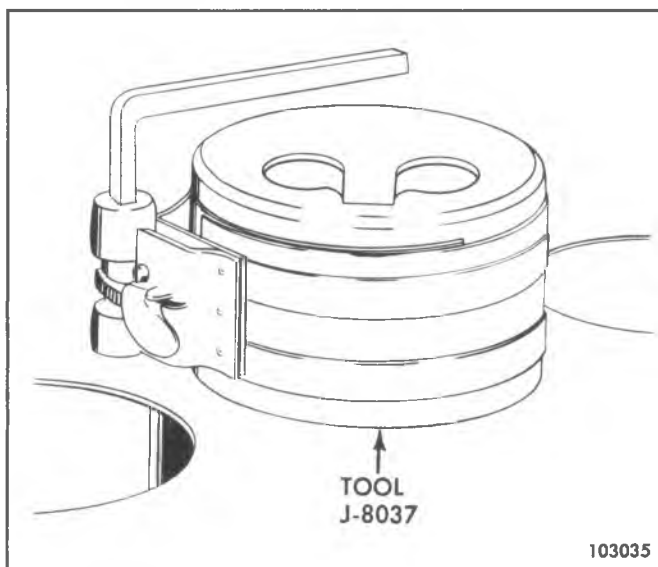

Fig. 6A7-42--Piston Ring Compressor

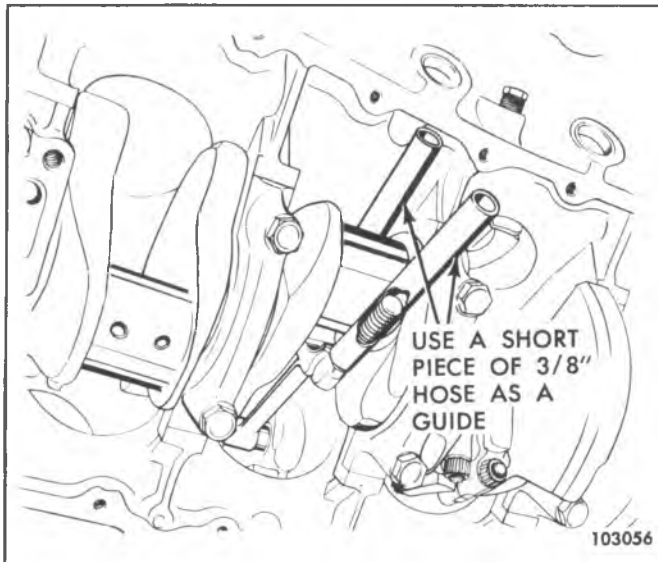

Fig. 6A7-43--Connecting Rod Bolt Guide

assembled toward outside of engine.

3. Install each connecting rod and piston assembly in its respective bore. Install with connecting rod bearing tang slots on side opposite camshaft. Use Tool J-8037 to compress the rings. Guide the connecting rod into place on the crankshaft journal. Use a hammer handle and light blows to install the piston into the bore. Hold the ring compressor firmly against the cylinder block until all piston rings have entered the cylinder bore.
4. Install the bearing caps and torque nuts to specifications 65 N·m (45 ft. lbs.). Be sure to install new pistons in the cylinders for which they were fitted, and used pistons in the cylinder from which they were removed. Each connecting rod and bearing cap should be marked, beginning at the front of the engine. Cylinders 1, 3, 5 and 7 in the left bank and, 2, 4, 6 and 8 in the right bank. The numbers on the connecting rod and bearing cap must be on the same side when installed in the cylinder bore. If a connecting rod is ever transposed from one block or cylinder to another, new

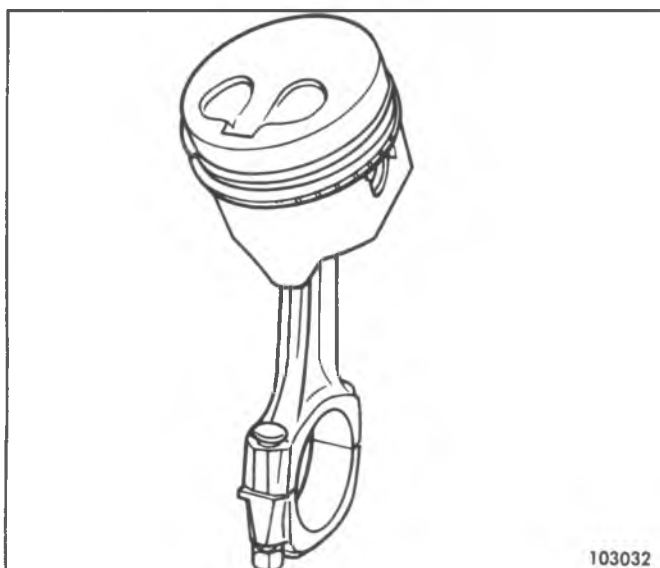

Fig. 6A7-44--Piston Identification

bearings should be fitted and the connecting rod should be numbered to correspond with the new cylinder number.

## CRANKSHAFT (Fig. 6A7-45)

### Removal

1. Remove engine.
2. Remove flywheel
3. Mount engine in stand and clamp securely.
4. Remove oil dipstick and tube.
5. Remove glow plugs.
6. Remove front cover as previously outlined.
7. Remove oil pan.
8. Remove oil pump.
9. Remove connecting rod caps. Install protective hose on connecting rod studs. Place bearings in a rack so they may be re-installed in their original location.
10. Remove main bearing caps. Place bearing caps in a rack so they may be re-installed in their original position.
11. Remove rear main bearing oil seal.
12. Remove rear main bearings from cylinder block and main bearing caps.

### Cleaning and Inspection

1. Wash crankshaft in solvent and dry with compressed air.
2. Measure dimensions of main bearing journals and crankpins with a micrometer for out-of-round, taper or undersize. (See Specifications.)
3. Check crankshaft for run-out by supporting at the front and rear main bearings journals in "V" blocks and check at the front and rear intermediate journals with a dial indicator. (See Specifications.)
4. Replace or recondition the crankshaft if out of specifications.

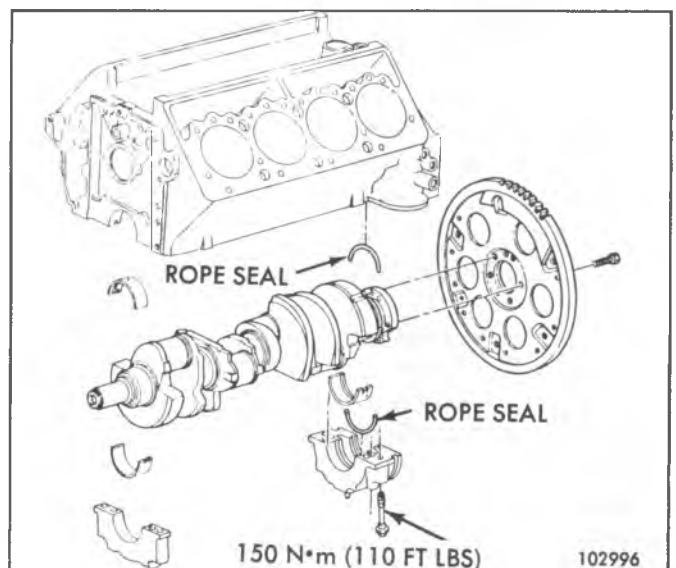

Fig. 6A7-45--Crankshaft

**Installation**

1. Apply a drop of sealer to bearing cap and cylinder and case groove prior to installing rope seal.
2. Install rear main oil seal in cylinder block and rear main cap. Seal must be firmly installed in place, in cylinder and case and bearing cap completely filling groove. End of seal must be cut clean and flush with cylinder case and bearing cap mounting surface.
3. Install main bearings in cylinder block and main bearing caps.
4. Torque all except rear main bearing cap bolts to specifications. Torque rear main cap to 14-16 N·m (10-12 in. lbs.) then tap end of crankshaft, first rearward then forward with lead hammer. This will line up rear main bearing and crankshaft thrust surface.
5. Install connecting rod bearings.
6. Reverse removal procedures.

**ENGINE ASSEMBLY****CK Truck****Removal**

1. Disconnect batteries.
2. Raise vehicle.
3. Remove transmission dust cover.
4. Disconnect torque converter.
5. Disconnect exhaust.
6. Remove starter bolts.
7. Disconnect wires and remove starter.
8. Remove transmission bell housing bolts.
9. Remove left motor mount bolts.
10. Remove right motor mount bolts.
11. Disconnect block heaters.
12. Remove wire harness, trans cooler lines and front battery cable clamp at oil pan.
13. Disconnect fuel return lines at engine.
14. Disconnect oil cooler lines at engine.
15. Remove lower fan shroud bolts.
16. Lower vehicle.
17. Remove hood.
18. Drain cooling system.
19. Remove air cleaner with resonator.
20. Remove primary filter from cowl.
21. Disconnect ground cable at alternator bracket.
22. Disconnect alternator wires and clips.
23. Disconnect TPS, EGR-EPR, Fuel cut off at injection pump.
24. Remove harness from clips at rocker covers includes disconnecting glow plugs.
25. Disconnect EGR-EPR solenoids, glow plugs, controller, temperature sender and move harness aside.
26. Disconnect ground strap, left side.
27. Remove fan.
28. Remove upper radiator hoses at engine.
29. Remove fan shroud.
30. Remove power steering pump and belt.

31. Remove power steering reservoir - lay pump and reservoir aside.
32. Disconnect vacuum at cruise servo and accelerator cable at injection pump.
33. Disconnect heater hose at engine.
34. Disconnect lower radiator hose at engine.
35. Disconnect oil cooler lines at radiator.
36. Disconnect heater hose and overflow at radiator.
37. Disconnect auto trans cooler lines.
38. Remove upper radiator cover.
39. Remove radiator.
40. Remove detent cable.
41. Remove engine, support transmission.

**Installation**

To install, reverse the removal procedures and include the following:

If fuel filters were removed, they must be filled with clean diesel fuel to avoid long cranking.

**G Van****Removal**

1. Disconnect batteries.
2. Remove headlight bezels.
3. Remove grille.
4. Remove bumper.
5. Remove lower valence panel.
6. Remove hood latch.
7. Remove coolant recovery bottle.
8. Remove upper fan shroud.
9. Remove upper tie bar.
10. Remove engine cover.
11. If equipped with A/C:
  - Discharge A/C system.
  - Disconnect A/C condenser lines.
  - Remove condenser.
12. Disconnect low coolant wire.
13. Drain cooling system.
14. Disconnect engine oil cooler lines at radiator.
15. Disconnect transmission cooler lines at radiator.
16. Disconnect lower radiator hose at radiator.
17. Disconnect upper radiator hose at radiator.
18. Remove radiator.
19. Remove fan assembly.
20. Remove fuel injection pump as outlined in 6.2 Diesel Fuel Injection Section.
21. Raise vehicle.
22. Disconnect exhaust pipe at manifold.
23. Remove inspection cover.
24. Remove flex plate to torque converter bolts.
25. Remove motor mount through bolt nuts.
26. Disconnect block heater at element and disconnect ground wire to block.
27. Remove bellhousing to cylinder case bolts.
28. Remove starter.
29. Lower vehicle.

## SPECIAL TOOLS

|             |  |               |   |
|-------------|--|---------------|---|
| J-6098-10   | Camshaft Brg Rem & Inst                          | J-33043-5     | T.P.S Gage Block                                      |
| J-26999-10  | Compression Gage Adapter                         | (.751 - .773) | LL4 (700R4 Transmission)                              |
| J-29134     | Piston Pin Retaining Ring                        | J-7049        | Valve Guide Reamer Set                                |
| J-29664     | Manifold Cover                                   | J-5830        | Valve Guide Reamer Set                                |
| J-29666     | Airline Adapter                                  | J-8037        | Piston Ring Compressor                                |
| J-29873     | Nozzle Socket                                    | J-22102       | Front Cover Seal Installer                            |
| J-33042     | Static Timing Gage                               | J-23523-D     | Harmonic Balancer Remover                             |
| J-33153     | Rear Main Seal Installer                         | J-8089        | Wire Brush, Combustion Chamber                        |
| J-33154     | Rear Main Seal Packer                            | J-8101        | Valve Guide Cleaner                                   |
| J-26513     | Valve Spring Compressor                          | J-8056        | Spring Tester   |
| J-6098.01   | Camshaft Brg Rem & Inst<br>(Used With J-6098-10) | J-8062        | Valve Spring Compressor                               |
| J-33043-2   | T.P.S And Vacuum                                 | J-29834       | Valve Lifter Remover                                  |
| (.646-.668) | Regulator Valve Gage Block                       | J-6098-11,-12 | Camshaft Brg Rem & Inst<br>(No's. 2,3,4, No. 5, No.1) |
| J-33043-4   | T.P.S Gage Block                                 |               |   |
| (.602-.624) |  |               |   |

103456

## Special Tools

30. If equipped with cruise control, remove cruise control transducer.
31. If equipped with A/C:
  - Remove rear A/C brace.
  - Disconnect A/C lines at compressor.
  - Remove A/C brackets and remove compressor.
32. Remove power steering pump and lay aside.
33. Remove oil fill tube upper bracket.
34. Remove glow plug relay.
35. Disconnect oil pressure sender and loom.
36. Remove air cleaner resonator and bracket.
37. Remove transmission fill tube nut and lay aside.
38. Disconnect heater and radiator and bypass hoses at crossover.
39. Remove generator upper bracket.
40. Remove coolant crossover.
41. Disconnect fuel lines at fuel pump.
42. Install J-33888 engine lifting device adapter.
43. Install lifting device.
44. Remove engine.

**Installation**

To install, reverse remove procedures.

GENERAL DATA:

|                   |                 |
|-------------------|-----------------|
| Type              | 90° V8 Diesel   |
| Displacement      | 6.2 Liter       |
| RPO               | LH6, LL4        |
| Bore              | 101 mm          |
| Stroke            | 97 mm           |
| Compression Ratio | 21.5:1          |
| Firing Order      | 1-8-7-2-6-5-4-3 |

CYLINDER BORE:

|                   |                  |
|-------------------|------------------|
| Diameter          | 100.987-101 .065 |
| Out of Round      | .02 Max.         |
| Taper-Thrust Side | .02 Max.         |

PISTON:

|                         |   |           |
|-------------------------|---|-----------|
| (Bores 1-6) Clearance * | B | .089-.115 |
|                         | Z | .112-.138 |

Bores 7&8 to be fit .013 Looser

PISTON RING:

|   |                  |     |           |
|---|------------------|-----|-----------|
| C<br>o<br>m<br>p<br>r<br>e<br>s<br>s<br>i<br>o<br>n | Groove Clearance | Top | .076-.178 |
|   |                  | 2nd | .039-.080 |
|   | Gap              | Top | .3-.55    |
|   |                  | 2nd | .75-1.0   |
| O<br>i<br>l   | Groove Clearance |     | .040-.096 |
|   | Gap              |     | 0.25-0.51 |

PISTON PIN:

|            |                 |
|------------|-----------------|
| Diameter   | 30.9961-31.0039 |
| Clearance  | .0101-.0153     |
| Fit in Rod | .0081-.0309     |

CAMSHAFT:

|                   |              |               |
|-------------------|--------------|---------------|
| + Lift<br>-.05    | In           | 7.133         |
|                   | Ex           | 7.133         |
| Journal Diameter  | # 1, 2, 3, 4 | 55.025-54.975 |
|                   | # 5          | 51.025-50.975 |
| Journal Clearance |              | .026-.101     |

CRANKSHAFT:

|                                      |                       |               |               |
|--------------------------------------|-----------------------|---------------|---------------|
| J<br>o<br>u<br>r<br>n<br>a<br>l      | Diameter              | # 1 2 3 4     | 74.917-74.941 |
|                                      |                       | # 5           | 74.912-74.936 |
|                                      | Taper                 |               | .005 Max.     |
|                                      | Out Of Round          |               | .005 Max.     |
| Main Bearing Clearance               | # 1, 2, 3, 4          | .045-.083     |               |
|                                      | # 5                   | .005-.093     |               |
| Crankshaft End Play                  |                       | 0.10-0.25     |               |
| C<br>r<br>a<br>n<br>k<br>p<br>i<br>n | Diameter              | 60.913-60.939 |               |
|                                      | Taper                 | .005 Max.     |               |
|                                      | Out Of Round          | .005 Max.     |               |
|                                      | Rod Bearing Clearance | .045-.100     |               |
|                                      | Rod Side Clearance    | .63/.17       |               |

VALVE SYSTEM:

|   |                  |           |             |
|---|------------------|-----------|-------------|
| Lifter  | Hydraulic Roller |           |             |
| Rocker Arm Ratio                                    | 1.5 to 1         |           |             |
| Face Angle (All)                                    | 45°              |           |             |
| Seat Angle (All)                                    | 46°              |           |             |
| Seat Runout   |                  | .05       |             |
| Seat Width  | In               | .89-1.53  |             |
|   | Ex               | 1.57-2.36 |             |
| Stem Clearance                                      | In               | .026/.069 |             |
|   | Ex               | .026/.069 |             |
| V<br>a<br>l<br>v<br>e<br>S<br>p<br>r<br>i<br>n<br>g | Pressure         | Closed    | 356 @ 46.0  |
|   | N @ mm           | Open      | 1025 @ 35.3 |
|   | Installed Height |           | 46          |

NOTICE: All dimensions are in millimetres (mm) unless otherwise specified.

- \* BOHN PISTONS
- \* ZOLLNER PISTONS

**ENGINE**

|  | <b>Ft. Lbs.</b> | <b>(N-m)</b> |
|--|-----------------|--------------|
| Injection Pump to Gear Bolts .....             | 13-20           | 18-27        |
| Injection Pump Attaching Nuts .....            | 25-37           | 34-50        |
| Injection Line Nut to Pump .....               | 15-24           | 20-32        |
| Injection Line Nut to Nozzle .....             | 15-24           | 20-32        |
| Injection Pump Fuel Filter Inlet Line .....    | 15-20           | 20-27        |
| Injection Pump Fuel Filter Outlet Line .....   | 15-20           | 20-27        |
| Injection Pump Fuel Inlet Line .....           | 15-20           | 20-27        |
| Injection Nozzle to Cylinder Head .....        | 44-60           | 60-80        |
| Glow Plug .....                                | 8-12            | 11-16        |
| Main Bearing Cap Bolts                         | 105-117         | 143-158      |
| Inner .....                                    |                 |              |
| Outer .....                                    | 94-105          | 128-143      |
| Oil Pump to Bearing Cap Bolts .....            | 59-74           | 80-100       |
| Rocker Arm Shaft Bolt to Head .....            | 41-44           | 55           |
| Valve Cover Bolts and Studs .....              | 13-20           | 18-27        |
| Oil Pan Bolts .....                            | 4-7             | 6-10         |
| Oil Pan Rear Bolts .....                       | 13-20           | 18-27        |
| Crankshaft Balancer to Crankshaft Bolt .....   | 140-162         | 190-220      |
| Front Cover to Cylinder Block .....            | 25-37           | 34-50        |
| Fan Driven Pulley to Hub Bolts .....           | 15-20           | 20-27        |
| Fan Clutch to Fan .....                        | 15-20           | 20-27        |
| Water Pump to Front Cover Bolts .....          | 25-37           | 34-50        |
| Water Pump to Cover Bolts M8—1.25 x 35 .....   | 15-20           | 20-27        |
| Water Pump Plate to Front Cover .....          | 13-20           | 18-27        |
| Water Pump Plate to Water Pump .....           | 13-20           | 18-27        |
| Thermostat Housing Crossover to Head .....     | 25-37           | 34-50        |
| Intake Manifold to Cylinder Head Bolts .....   | 25-37           | 34-50        |
| Exhaust Manifold to Cylinder Head Bolts .....  | 18-25           | 25-35        |
| Engine Mount to Cylinder Block Bolts .....     | 30-40           | 40-54        |
| Engine Mount to Frame Mount .....              | 25-35           | 34-48        |
| Vacuum Pump Clamp to Cylinder Block Bolt ..... | 25-37           | 34-50        |
| Cylinder Head Bolts .....                      | 88-103          | 120-140      |
| Connecting Rod Nuts .....                      | 44-52           | 60-70        |
| Camshaft Sprocket Bolt .....                   | 55-66           | 75-90        |
| Lifter Guide Plate Retainer .....              | 13-25           | 18-35        |
| Camshaft Thrust Plate .....                    | 13-20           | 18-27        |
| Fuel Pump To Block .....                       | 20-30           | 27-40        |
| Fuel Pump Adapter Plate to Block .....         | 4-7             | 6-10         |
| Fuel Filter Adapter To Inlet Manifold .....    | 25-37           | 34-50        |





## SECTION 6B

# ENGINE COOLING

### CONTENTS

|                          |      |                               |       |
|--------------------------|------|-------------------------------|-------|
| General Description..... | 6B-1 | On Vehicle Service .....      | 6B-11 |
| Coolant Level .....      | 6B-1 | Fan Shroud .....              | 6B-11 |
| Thermostat .....         | 6B-2 | Water Pump .....              | 6B-13 |
| Drive Belts .....        | 6B-2 | Thermostat .....              | 6B-15 |
| Diagnosis .....          | 6B-8 | Radiator .....                | 6B-15 |
| System Checks .....      | 6B-8 | Fan/Fan Clutch .....          | 6B-16 |
| Overheat/Noise .....     | 6B-8 | Coolant Recovery Bottle ..... | 6B-18 |
| Fan Clutch .....         | 6B-9 | Engine Oil Cooler .....       | 6B-19 |

## GENERAL DESCRIPTION

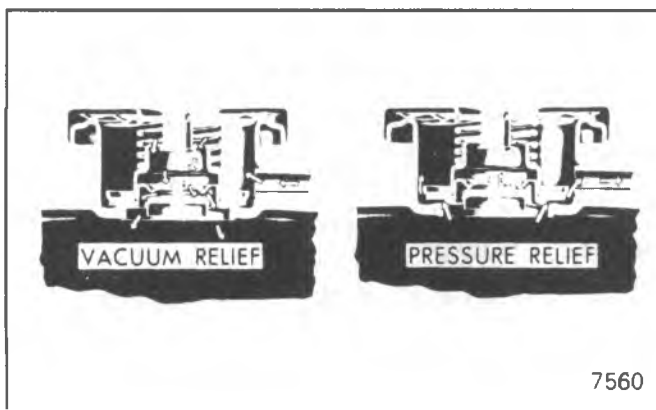

Fig. 6B-1--Radiator Pressure Cap

All Chevrolet Light Duty Trucks have pressure type engine cooling systems with thermostatic control of coolant circulation. The cooling system is sealed by a pressure type radiator filler cap which causes the system to operate at higher than atmospheric pressure. The higher pressure raises the boiling point of the coolant which increases the cooling efficiency of the radiator. The 15 pound (103 kPa) pressure cap used raises the boiling point of coolant to approximately 258° F (125°C) at sea level.

The radiator cap should be washed with clean water and pressure checked every 12 months.

All models have a closed cooling system using a round pressure cap (Fig. 6B-1) and a coolant reservoir. Coolant can be added without removing the radiator cap.

A pressure-vacuum valve radiator cap is used which allows the coolant to expand through the pressure valve in the center of the cap without building unnecessary pressure. The expanding coolant flows into the coolant reservoir. The vent valve closes due to expansion and coolant flow. The nominal 15 pound (103 kPa) pressure will not be reached until the system is working at maximum capacity.

Any air or vapor in the cooling system will be forced to the coolant reservoir under the liquid level and leave through the vent tube at the top of the reservoir. As the system cools, the extra coolant in the reservoir will be drawn back to the radiator through the vent valve. In this manner, the radiator will keep itself full at all times.

### COOLANT LEVEL

The need for additional coolant can be detected by observing the level of coolant in the "see through" reservoir while the engine is at normal operating temperature. The radiator cap need not normally be removed.

The coolant level should be at the "Full Cold" mark when the system is cool or at ambient temperature. After the vehicle has been driven sufficiently to obtain normal operating temperatures, the level should be above the "Full Cold" mark.

Periodically, the radiator cap should be removed to observe coolant level in the radiator.

**CAUTION: The radiator coolant level should only be checked when the engine is cool. If the radiator cap is removed from a hot cooling system, serious personal injury may result.**

Coolant levels in crossflow radiators with coolant recovery bottles should be maintained to the top of the filler neck.

The recovery bottle should be at its appropriate mark when checked.

Regardless of whether freezing temperatures are expected or not, cooling system protection should be maintained at least to -20°F (-29°C), to provide adequate corrosion protection and loss of coolant from boiling. With glycol content less than requirement for -20°F (-29°C) protection, coolant boiling point is less than the temperature indicating light setting. When adding solution due to loss of coolant for any reason or in areas where temperatures lower than -20°F (-29°C) may occur, a sufficient amount of an ethylene glycol base anti-freeze that meets a GM Specification 1825-M should be used.

**NOTICE:** Alcohol or methanol base anti-freeze, or plain water, are not recommended for your engine at anytime. They will not provide proper protection against corrosion.

### Flushing Cooling System

Various methods and equipment may be used to perform this service. If special equipment such as a back flusher is used, equipment manufacturer's instructions should be followed. However, it is advisable to remove the thermostat

| ALL L6 ENGINES AND ALL V8 ENGINES<br>EXCEPT DIESEL |             |   |
|--|-------------|---|
| GENERATOR<br>A.I.R. PUMP<br>P/S PUMP               | NEW<br>USED | 578 N (130 lb.)<br>222-356 N (50-80 lb.)  |
| A/C<br>COMPRESSOR                                  | NEW<br>USED | 645 N (145 lb.)<br>289-445 N (65-100 lb.) |
| 6.2L - V8 DIESEL                                   |             |   |
| GENERATOR<br>P/S PUMP<br>A/C<br>COMPRESSOR         | NEW<br>USED | 778 N (175 lb.)<br>245-445 N (55-100 lb.) |

Fig. 6B-2--Drive Belt Tension Specifications

before flushing the system.

### THERMOSTAT

The thermostat consists of a restriction valve actuated by a thermostatic element. This is mounted in the housing at the cylinder head coolant outlet above the water pump on L-6, and in the forward part of the intake manifold, under the coolant outlet on "small block" and "Mark". Thermostats are designed to open and close at predetermined temperatures and if not operating properly should be removed and tested.

The thermostat for the 6.2L diesel is mounted in the coolant crossover pipe located at the front of the engine. Refer to Fig. 6B-3.

### DRIVE BELTS

Frayed or cracked belts should be replaced and tensioned to specifications using a strand tension gage,

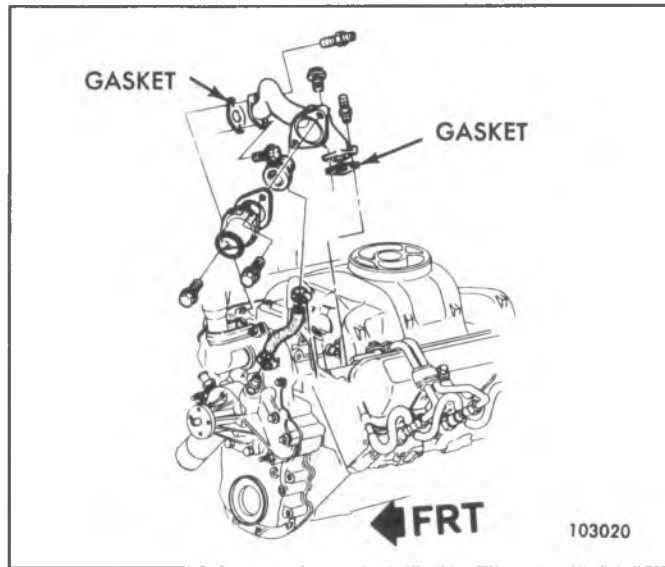

Fig. 6B-3--Thermostat Housing 6.2L Diesel

such as tool J-23600-B or equivalent.

Loose belts may place an extremely high impact load on driven component bearings due to the whipping action of the belt.

An over tightened belt places unnecessary loads on the component bearings.

In figure 6B-2, the minimum reading is the lowest allowable setting before the belt must be reset. When readjusting, the adjustment specification should be met. When adjusting a drive belt, it is important that the proper adjustment specification be used. Refer to figures 6B-4 thru 6B-7 for adjustment.

- A 'Used' belt is one that has been rotated at least one complete revolution on engine pulleys. This begins the 'seating' of the belt and it should never be reset to 'New' belt specifications.

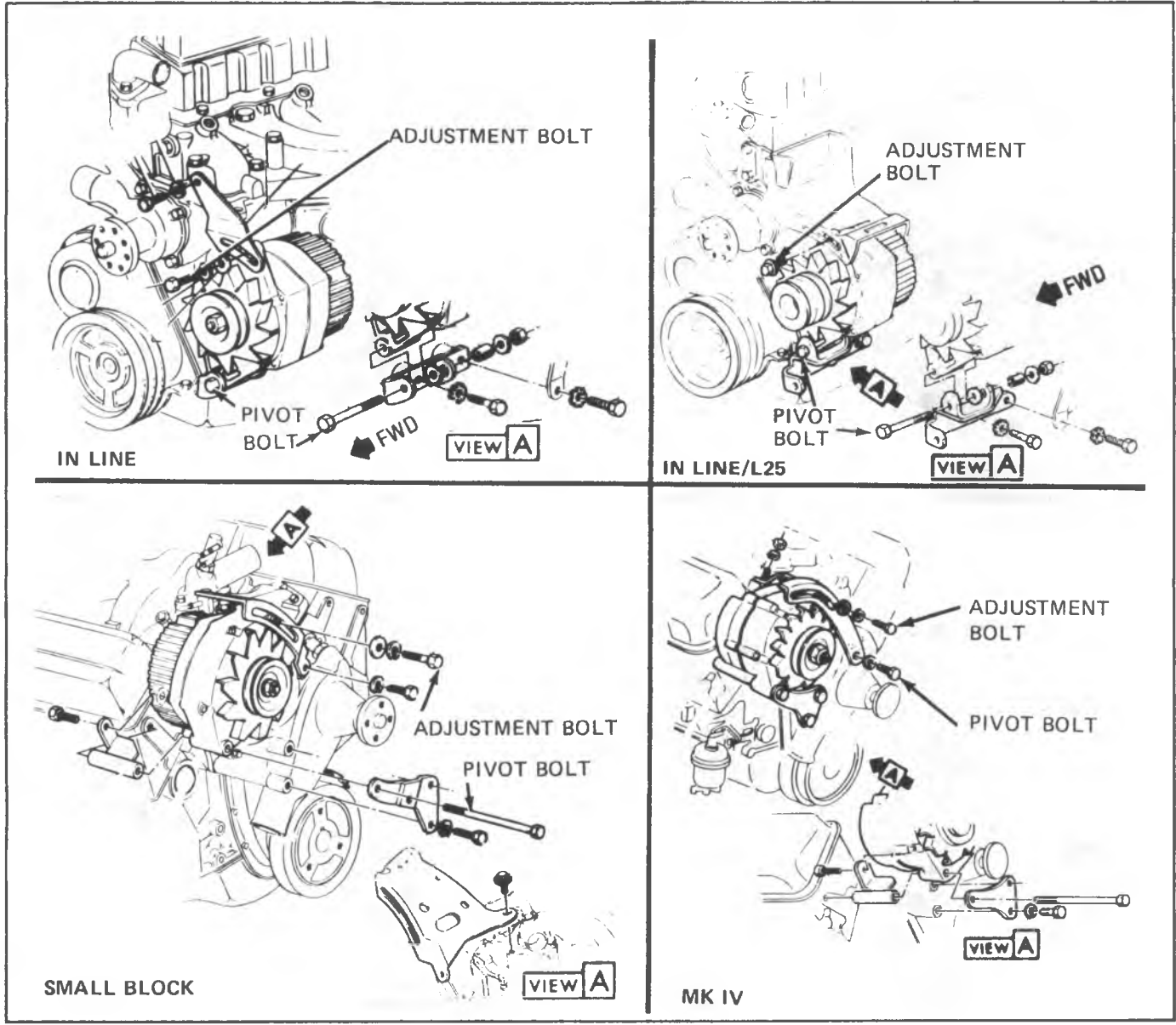

Fig. 6B-4-Generator Adjustment

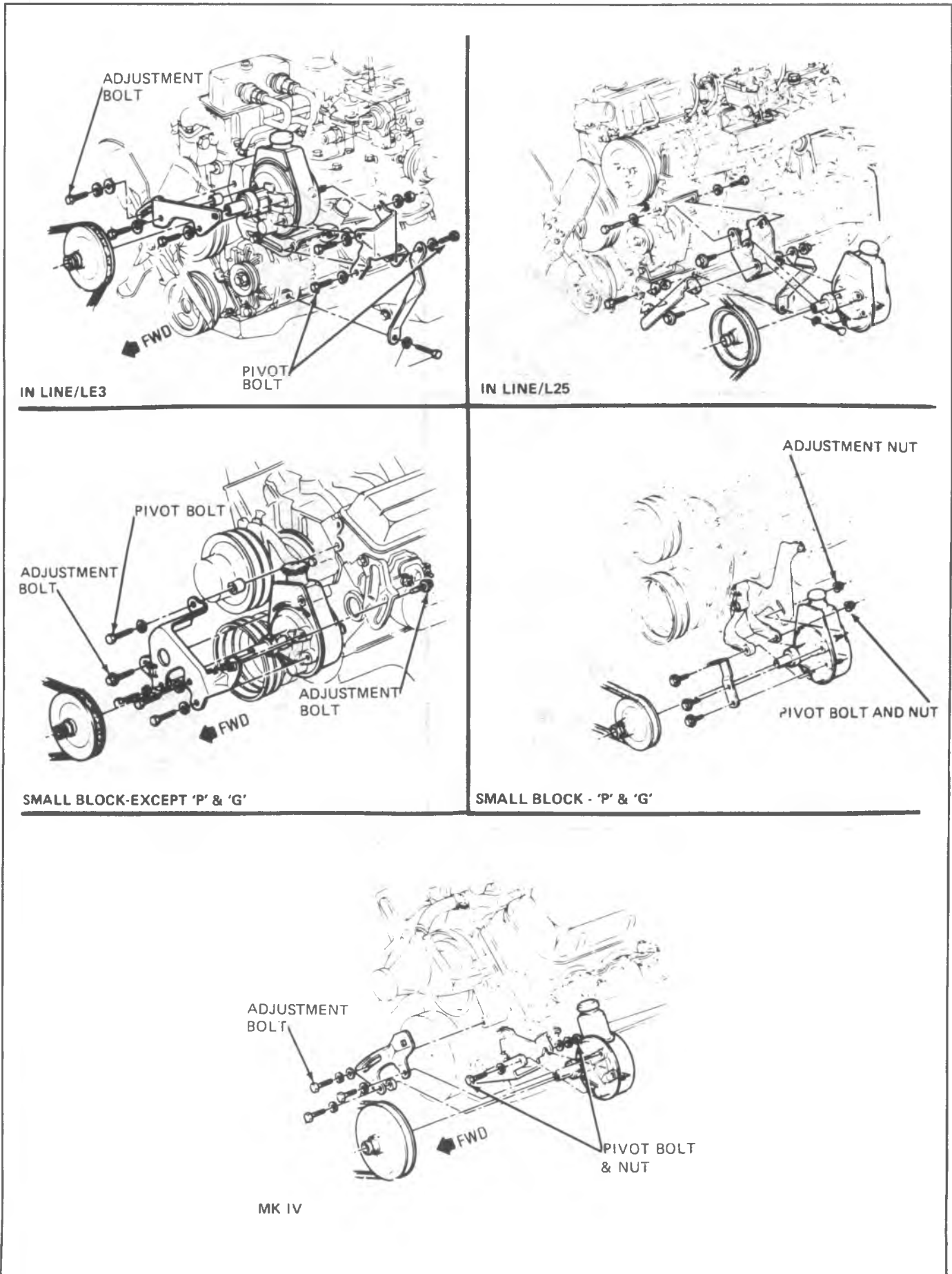
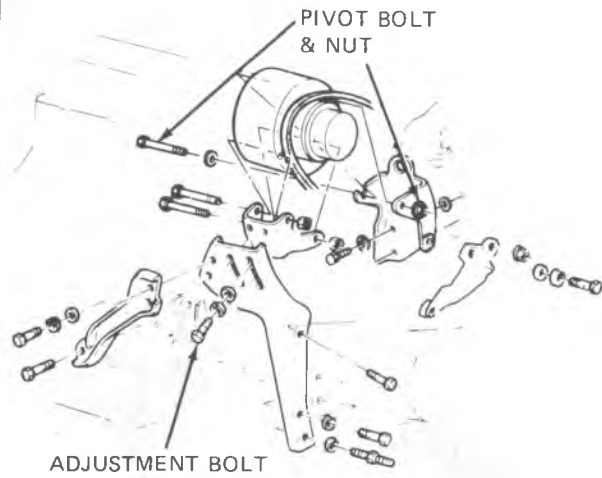
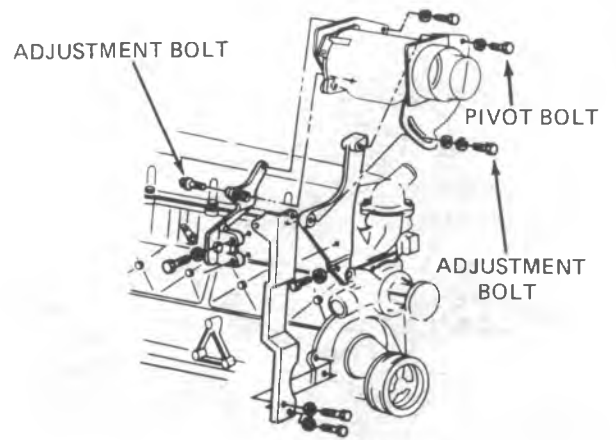

Fig. 6B-5--P/S Pump Adjustment



IN LINE-EXCEPT 'G'



IN LINE-'G' MODEL

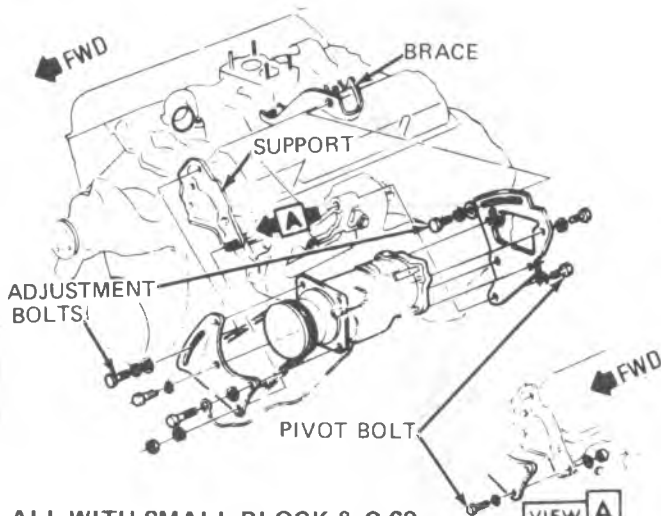

ALL WITH SMALL BLOCK & C-69  
SMALL BLOCK-EXCEPT 'G', LS9, LT9, L69

VIEW A  
EXC N41

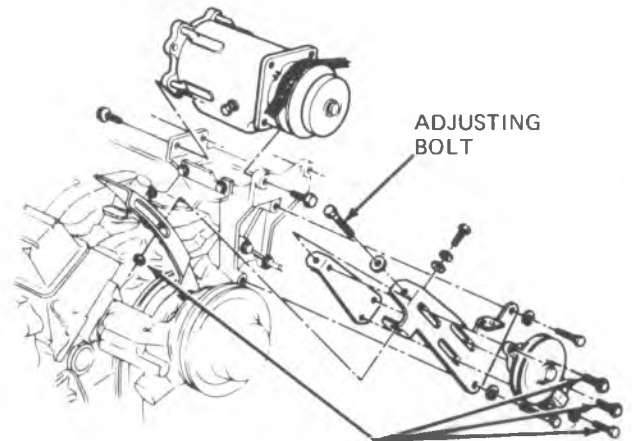

LOOSEN (4) AND  
TURN ADJUSTING BOLT

SMALL BLOCK 'G' MODEL

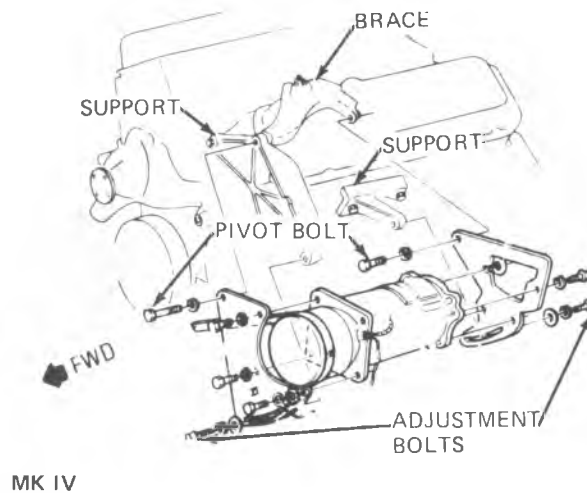

MK IV

Fig. 6B-6--A/C Compressor Adjustment

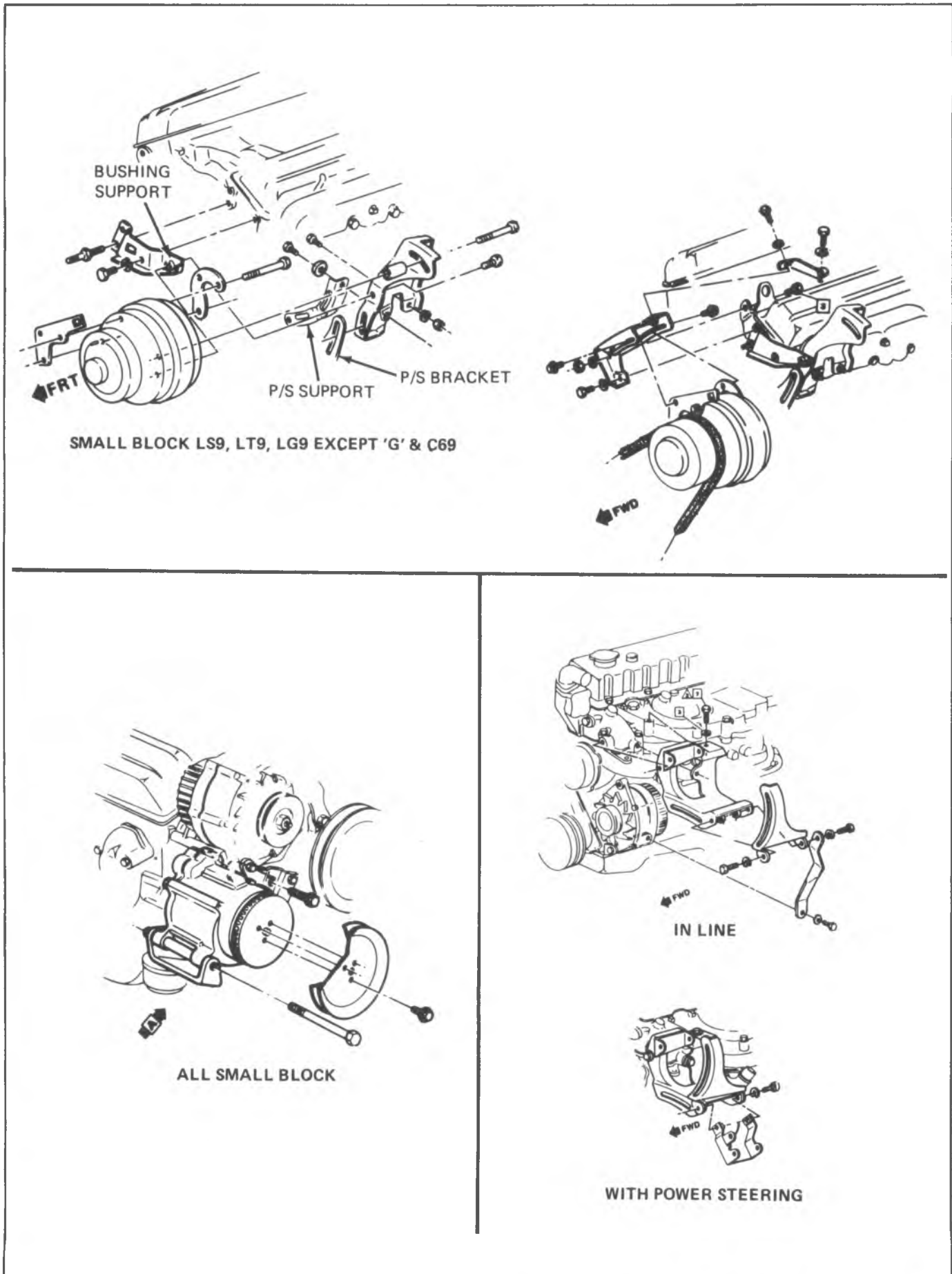

Fig. 6B-7--A/C and A.I.R. Adjustment

*Carburetor Reaction  
See pg 6E159*

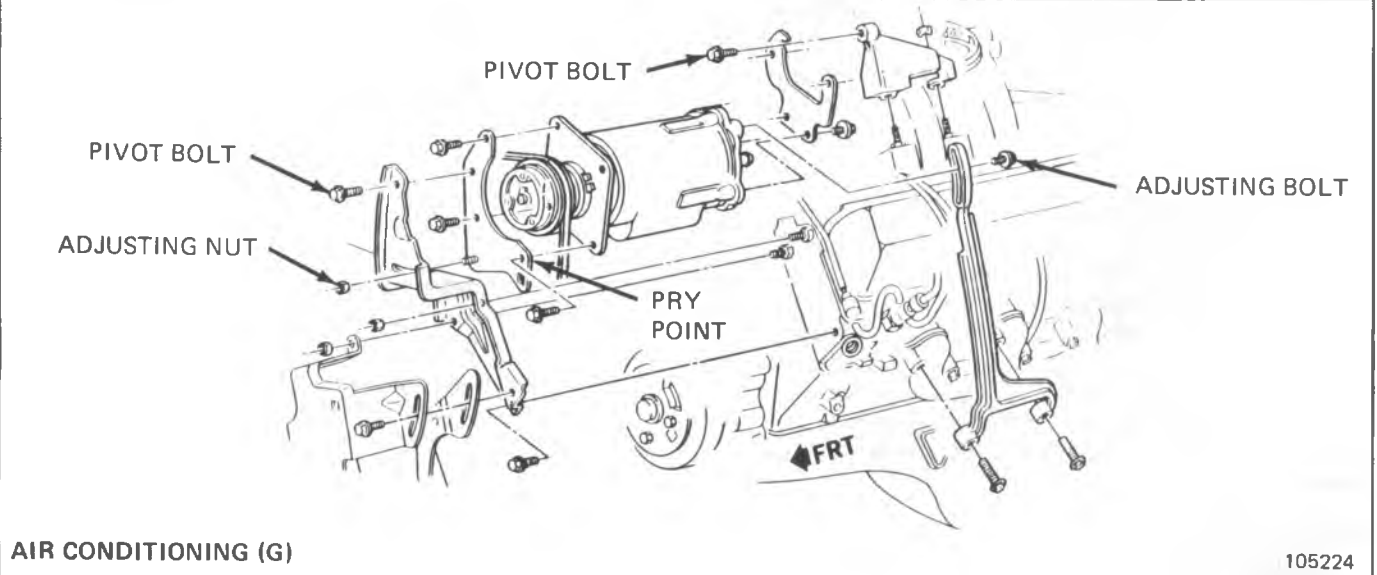
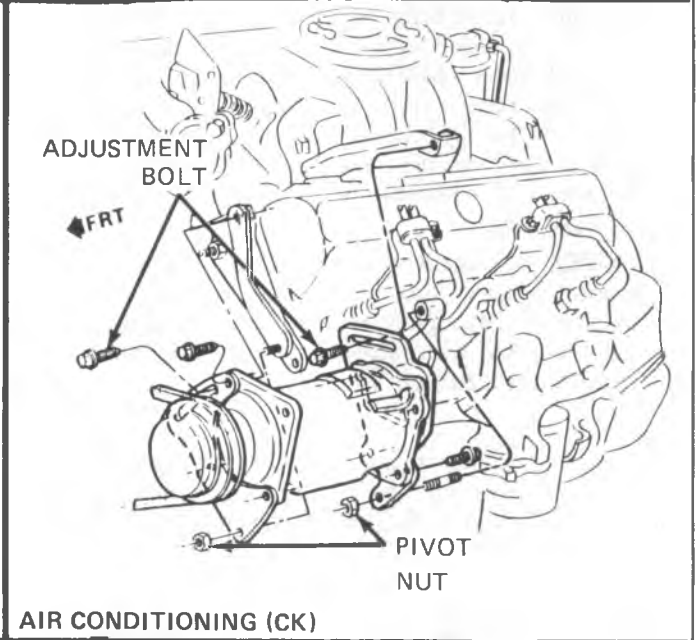
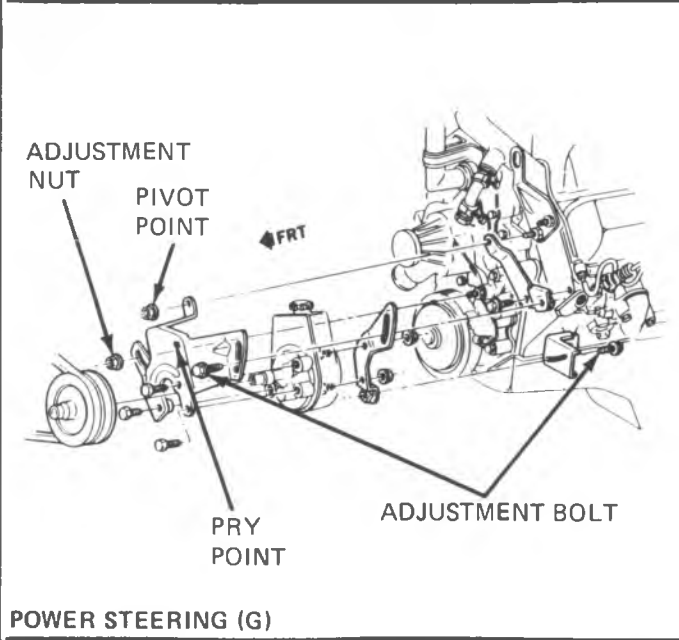
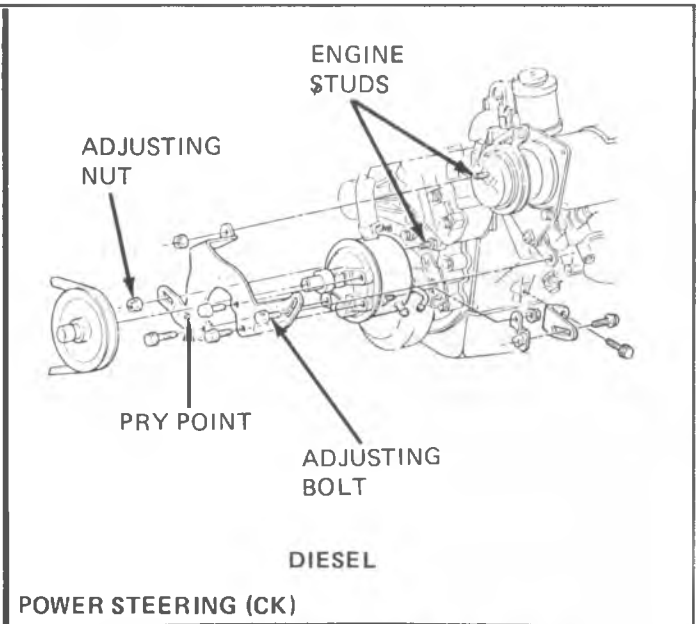
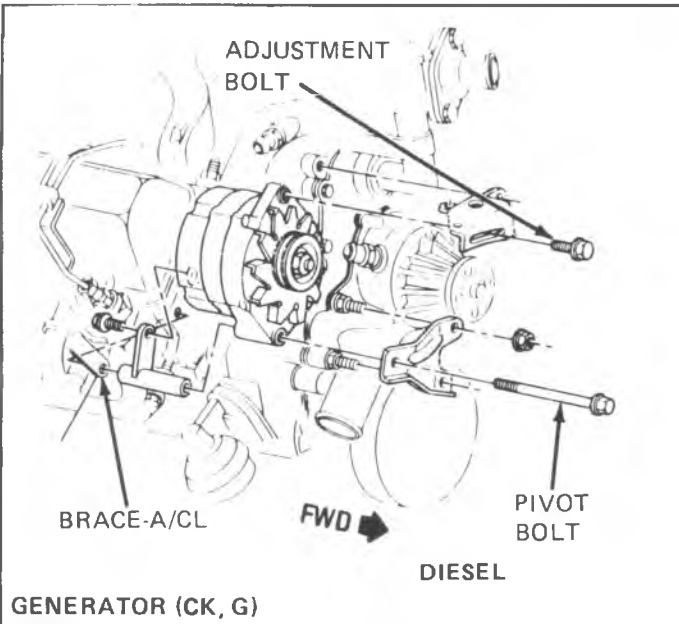

Fig. 6B-8--Diesel Drive Belt Adjustments



## DIAGNOSIS

If the cooling system requires frequent addition of coolant in order to maintain the proper level, check all units and connections in the cooling system for evidence of leakage. Inspection should be made with cooling system cold. Small leaks which may show dampness or dripping can easily escape detection when the engine is hot, due to the rapid evaporation of coolant. Tell-tale stains of grayish white or rusty color, or dye stains from anti-freeze, at joints in cooling system are almost always sure signs of small leaks even though there appears to be no damage.

Air may be drawn into the cooling system through leakage at the water pump seal or through leaks in the coolant recovery system. Gas may be forced into the cooling system through leakage at the cylinder head gasket(s) even though the leakage is not sufficient to allow coolant to enter the combustion chamber.

### SYSTEM CHECKS

#### Exhaust Leaks

To check for exhaust leaks into the cooling system, drain the system until the coolant level stands just above the top of the cylinder head(s), then disconnect the radiator upper hose and remove the thermostat and fan belt(s). Start the engine and quickly accelerate several times. At the same time note any appreciable coolant rise or the appearance of bubbles which are indicative of exhaust gases leaking into the cooling system.

**NOTICE:** A defective head gasket may allow exhaust gases to leak into the cooling system. This is particularly damaging to the cooling system as the gases combine with the water to form acids which are harmful to the radiator and engine.

#### Water Pump

Water pump operation may be checked by running the engine while squeezing the radiator upper hose (engine warm). A pressure surge should be felt. Check for a plugged venthole in pump.

#### Radiator

Test for restriction in the radiator, by warming the engine up and then turning the engine off and feeling the radiator. The radiator should be hot along the left side and warm along the right side, with an even temperature rise from right to left. Cold spots in the radiator indicate clogged sections.

#### Thermostat

An operational check of the thermostat can be made by hanging the thermostat on a hook in a 33% glycol solution 25°F (4°C) above the temperature stamped on the thermostat valve. Submerge the valve completely and agitate the solution thoroughly. Under this condition the valve should open. Remove the thermostat and place in a 33% glycol solution 10°F (-12°C) below temperature indicated on the valve. With valve completely submerged and coolant agitated thoroughly, the valve should close completely.

#### Overheat and/or Noise

Engine overheat and/or cooling system noise may be caused by restrictions in the cooling system.

Components which may be prone to this condition are cylinder head, water pump, block, thermostat housing and inlet manifold. Symptoms of this condition are as follows:

- Engine may make snapping/cracking noises.
- Heater core may gurgle or surge.
- Radiator hoses may collapse and expand.
- Heater hoses may vibrate and thump.
- Overheat light may or may not come on.

Symptoms are the result of coolant boiling at some localized area and may be noticed after extending idling and/or while being driven. Determine which side of the engine is involved and whether it is more at the front or rear of engine.

#### Diagnosis/Inspection

1. Isolate area of engine the localized boiling is originating from. This can be done by probing engine with a sounding bar (large screw driver).
2. With radiator cap removed, observe water being circulated in radiator. Feel the front area of radiator for cold spots which indicate blockage. Blocked radiators generally occur on units that have accrued miles and not on new vehicles.

**CAUTION:** The radiator cap should be removed from a cool engine only. If the radiator cap is removed from a hot cooling system, serious personal injury may result.

3. Inspect thermostat to see if it opens completely.
4. Inspect thermostat housing to make sure it is completely free of obstructions.
5. Remove water pump from vehicle and remove the back cover on the pump. All internal passages can be inspected using a flash light.
6. Inspect cross over at the front of the inlet manifold. This entire passage can be seen with only the thermostat removed.
7. Remove heads, but lay them aside for now and check the block first because the heads are the most complex pieces as far as coolant passages are concerned.
8. With water pump and heads removed, ALL coolant passages CAN be inspected by using a pen light flash light. All water jacket areas can be seen directly and a block should never be replaced as being suspect unless the restricted area can be **DIRECTLY SEEN**.
9. If none of the above inspections reveal the problem area, the heads must be considered prime suspect. Heads with blocked coolant passages generally have more than one area that is blocked. Inspect the heads for signs of overheat discoloration (a dark blue or black area). If none are found look in the coolant passages for blockage and probe all passages that are accessible.

The head is very intricate and all passages cannot be reached. Use a probe that is fairly substantial as a tag wire may go through or around a partially blocked area. If nothing is found by visual inspection and probing, inspect the passages for a rough ragged appearance. The roughest internal passages are probably the ones that are blocked.

Replace a blocked or suspect head and inspect the

replacement head in the same manner before installing it.

## FAN CLUTCH

### 1.- Noise

Fan noise is sometimes evident under the following normal conditions:

- When clutch is engaged for maximum cooling.
- During first few minutes after start-up until the clutch can re-distribute the silicone fluid back to its normal disengaged operating condition after overnight settling.

Fan noise or an excessive roar will generally occur continuously, however, under all high engine speed conditions (2500 r.p.m. and up) if the clutch assembly is locked up due to an internal failure. If the fan cannot be rotated by hand or there is a rough grating feel as the fan is turned, the clutch should be replaced.

### 2. - Looseness

Under various temperature conditions, there is a visible lateral movement that can be observed at the tip of the fan blade. This is a normal condition due to the type of bearing used. Approximately 1/4" (6.5mm) maximum lateral movement measured at the fan tip is allowable. This is not cause for replacement.

### 3. - Silicone Fluid Leak

The operation of the unit is generally not affected by small fluid leaks which may occur in the area around the bearing assembly. If the degree of leakage appears excessive, however, proceed to item 4.

### 4. - Engine Overheating

If the fan and clutch assembly free-wheels with no drag (revolves over 5 times when spun by hand), the clutch should be replaced.

ENGINE COOLING SYSTEM COMPLAINT

TO AVOID NEEDLESS TIME AND COST IN DIAGNOSING COOLING SYSTEM COMPLAINTS, THE CUSTOMER SHOULD BE QUESTIONED ABOUT DRIVING CONDITIONS THAT PLACE ABNORMAL LOADS ON THE COOLING SYSTEM.

1. DOES OVERHEATING OCCUR WHILE PULLING A TRAILER?

IF ANSWER IS "YES" – HOW HEAVY IS TRAILER? IF TRAILER WEIGHT IS GREATER THAN 2,000 LBS. & VEHICLE IS EQUIPPED WITH NORMAL DUTY COOLING SYSTEM, A HEAVY DUTY COOLING PACKAGE IS REQUIRED [PER MFR'S TRAILER HAULING SPECS.]. FURTHER DIAGNOSTIC CHECKS SHOULD NOT BE REQUIRED.

2. IS VEHICLE EQUIPPED WITH ADD-ON OR AFTER MARKET AIR CONDITIONING SYSTEM?

IF ANSWER IS "YES" – WAS HEAVY DUTY RADIATOR INSTALLED WITH THE SYSTEM? IF NOT, INSTALL HEAVY DUTY AIR CONDITIONING RADIATOR FOR THE CAR MODEL INVOLVED [PER MANUFACTURER'S SPECS.]. FURTHER DIAGNOSTIC CHECKS SHOULD NOT BE REQUIRED.

3. IS OVERHEATING OCCURRING AFTER PROLONGED IDLE, IN GEAR, A/C SYSTEM OPERATING?

IF ANSWER IS "YES" – INSTRUCT OWNER ON DRIVING TECHNIQUES THAT WOULD AVOID OVERHEATING SUCH AS:

- a. IDLE IN NEUTRAL AS MUCH AS POSSIBLE – INCREASE ENGINE R.P.M. TO GET HIGHER AIR FLOW & WATER FLOW THROUGH RADIATOR.
  - b. TURN A/C SYSTEM OFF DURING EXTENDED IDLES IF OVERHEATING IS INDICATED BY HOT LIGHT OR TEMP. GAGE.
- FURTHER DIAGNOSTIC CHECKS SHOULD NOT BE REQUIRED.

4. IS OVERHEATING OCCURRING AFTER PROLONGED DRIVING IN SLOW CITY TRAFFIC, TRAFFIC JAMS, PARADES, ETC.?

IF ANSWER IS "YES" – INSTRUCT OWNER ON DRIVING TECHNIQUES THAT WOULD AVOID OVERHEATING – SAME AS FOR PROLONGED IDLES – NO. 3. FURTHER DIAGNOSTIC CHECKS SHOULD NOT BE REQUIRED.

IF NONE OF THE ABOVE APPLY, GO TO DIAGNOSTIC CHART

TO EFFECTIVELY USE THIS CHART, QUESTION THE OWNER TO DETERMINE WHICH OF THE FOLLOWING [3] CATEGORIES APPLIES TO THE COMPLAINT:

1. HOT LIGHT OR HOT INDICATION ON TEMPERATURE GAGE
2. BOILING
3. COOLANT LOSS

1. IF COMPLAINT IS HOT LIGHT OR HOT INDICATION ON TEMPERATURE GAGE –

WAS HOT LIGHT ACCOMPANIED BY BOILING? IF ANSWER IS "YES", GO TO BOILING ON CHART  
IF ANSWER IS "NO", GO TO HOT LIGHT ON CHART

2. IF COMPLAINT IS BOILING – GO TO BOILING ON CHART3. IF COMPLAINT IS COOLANT LOSS –

DETERMINE IF CUSTOMER IS OVERFILLING THE SYSTEM, THIS WOULD NORMALLY RESULT IN SMALL AMOUNTS OF COOLANT LOSS THROUGH THE OVERFLOW TUBE. IF THIS IS THE CASE, INSTRUCT THE CUSTOMER ON PROPER FILL LEVEL & NO FURTHER DIAGNOSTIC CHECKS SHOULD BE REQUIRED.

IF OVERFILLING IS NOT THE PROBLEM, GO TO COOLANT LOSS ON CHART.

NOTICE: ANYTIME COOLING SYSTEM IS OBVIOUSLY CONTAMINATED, THE SYSTEM SHOULD BE DRAINED AND FLUSHED.

CAUTION – THE COOLING SYSTEM IS DESIGNED TO OPERATE AT 15 P.S.I. PRESSURE & TEMPERATURES EXCEEDING 200° F. CAUTION SHOULD BE EXERCISED WHEN REMOVING PRESSURE CAP OR SERVICING THE SYSTEM.

## DIAGNOSIS CHART

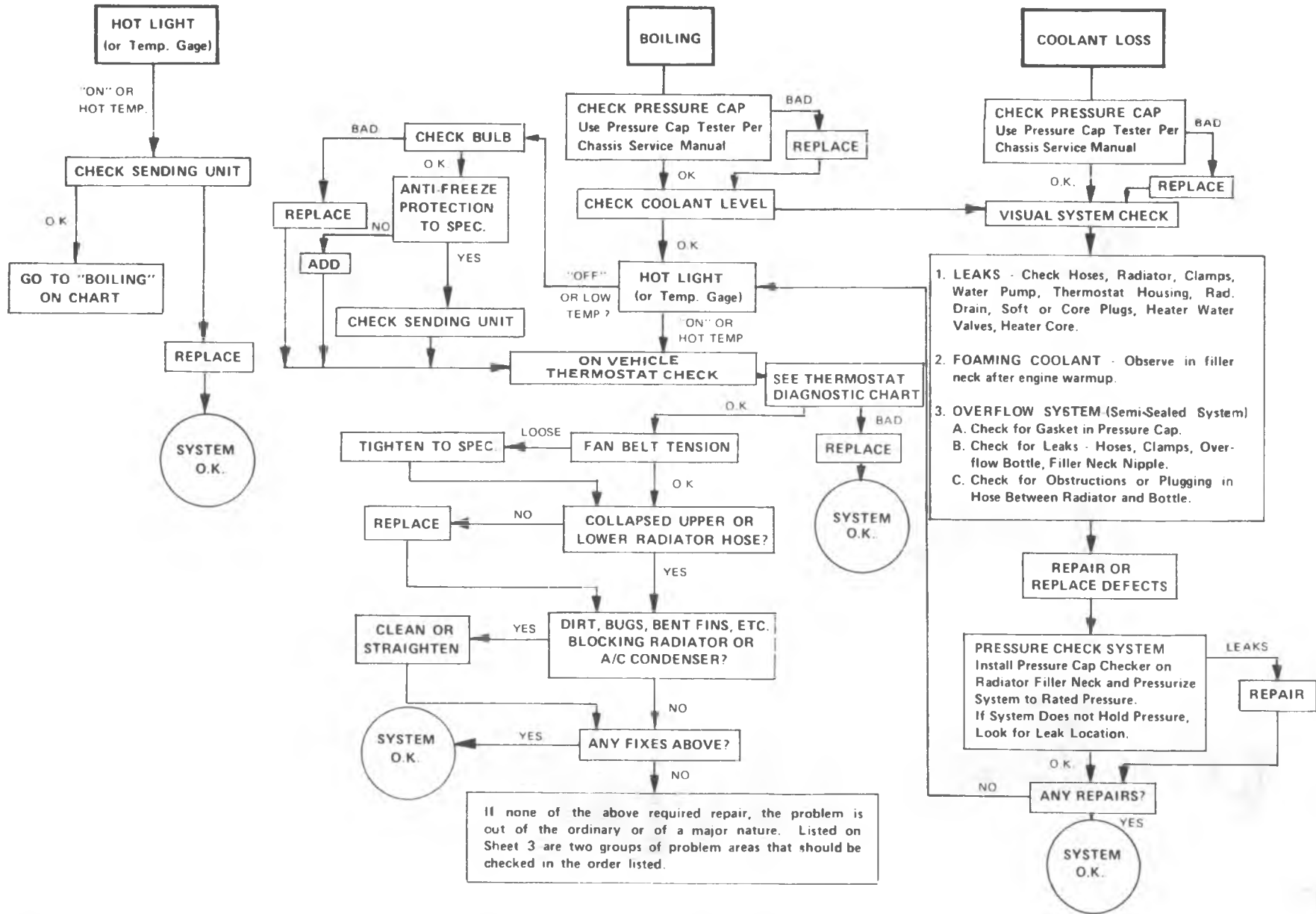

## ON VEHICLE SERVICE

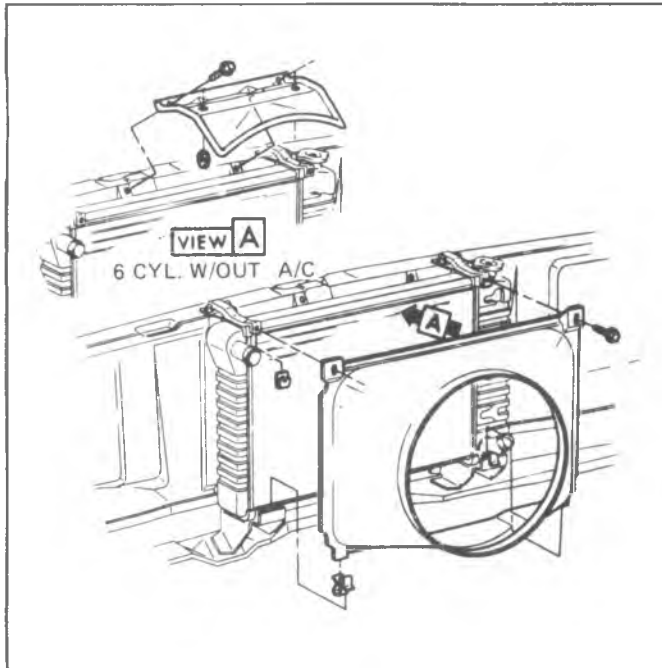

Fig. 6B-9--"G" Van Fan Shroud

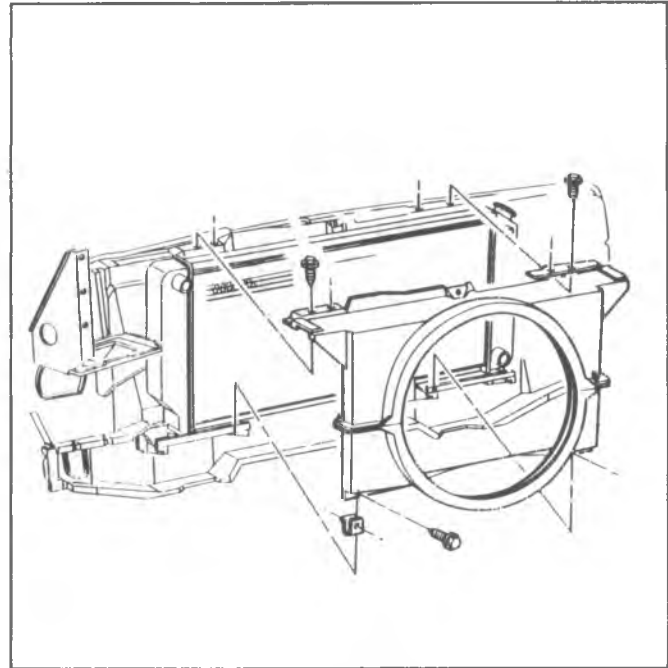

Fig. 6B-10 "G" Van Fan Shroud Diesel

### FAN SHROUD (FIGS. 6B-9 THRU 6B-13)

#### Removal (CK Series)

1. Disconnect battery negative cable.
2. Remove fan shroud to radiator retainer attaching screws.
3. Remove fan clutch to water pump hub attachments.
4. Remove shroud by pulling up and out of lower retaining clips. Fan shroud and fan clutch assembly must be removed together.

#### Installation (CK Series)

1. Lower fan shroud and fan clutch along back of radiator. Make sure lower edge fits into lower retaining clips.

2. Install fan clutch to water pump attachments and torque to 27 N·m.
3. Install shroud to radiator retainer attaching screws. Torque to 6 N·m.
4. Connect battery negative cable.

#### Removal ("G" Series-V8 Engines)

1. Disconnect battery negative cable.
2. If A/C equipped, remove vacuum reservoir.
3. Remove windshield washer jar and bracket.
4. Remove shroud retaining screws.
5. Remove radiator support bracket.
6. Remove dip stick from engine (transmission also if equipped with automatic).

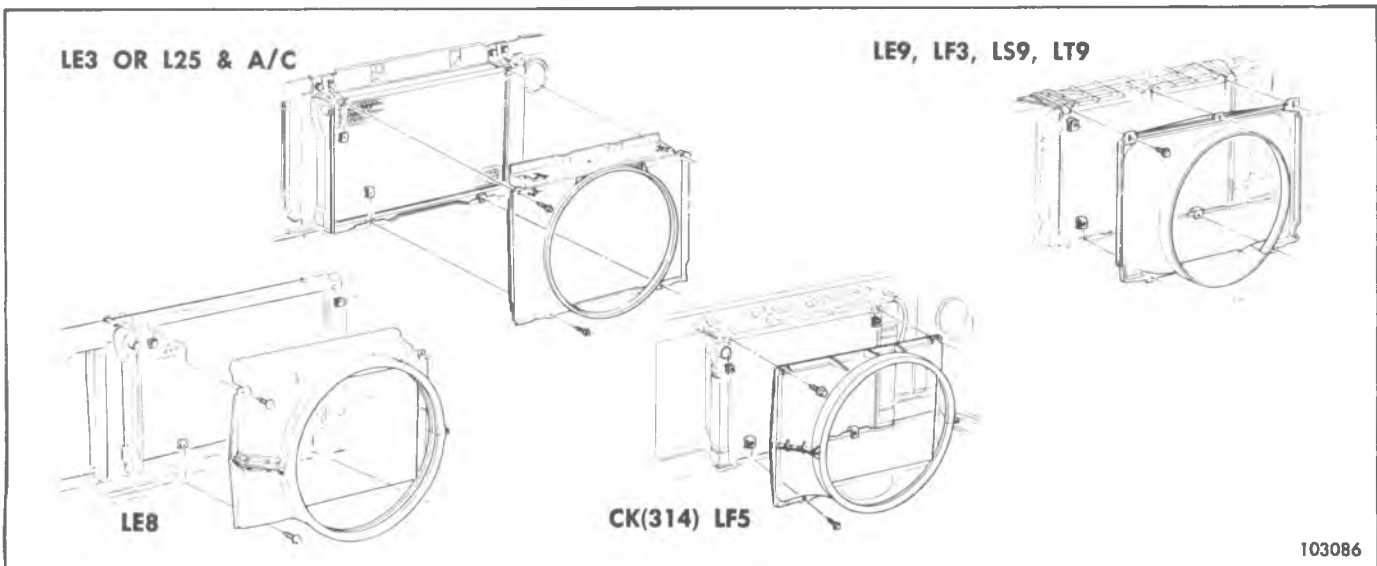

Fig. 6B-11--"CK" Series Fan Shroud

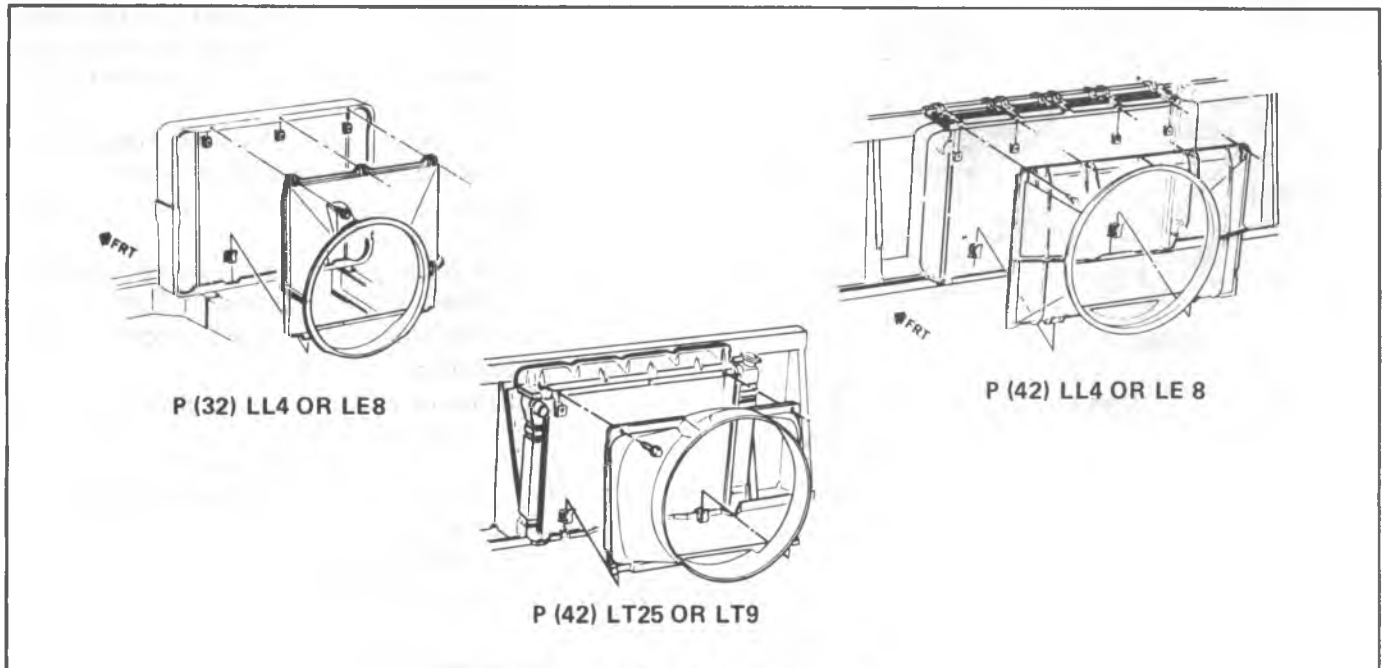

Fig. 6B-12--"P" Series Fan Shroud

7. Remove radiator hose strap from shroud.
8. Remove fan shroud from water pump (leave pulley), then remove fan and shroud together.

#### Installation ("G" Series-V8 Engines)

1. Install fan and shroud together then, attach fan to water pump.
2. Attach radiator hose strap to shroud.
3. Install dipstick in engine and, where applicable, in transmission.
4. Install radiator support bracket.
5. Install shroud retaining screws.
6. Install windshield washer jar and bracket.
7. If equipped with A/C, install vacuum reservoir.
8. Connect battery cable.

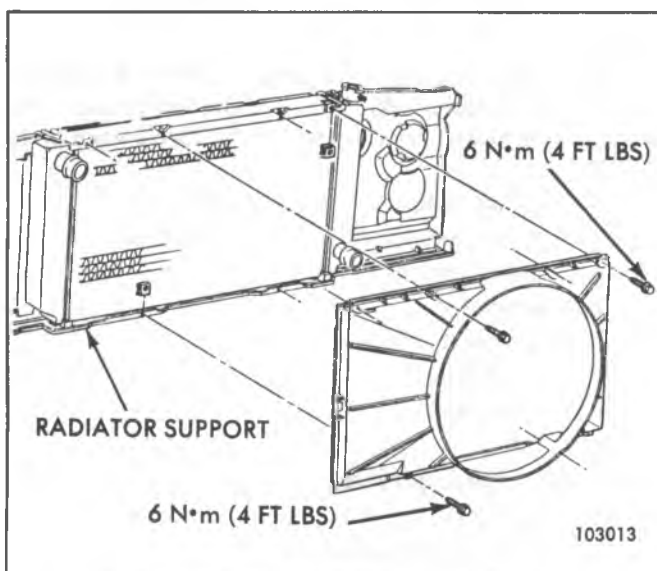

Fig. 6B-13--Fan Shroud 6.2L Diesel-CK Models

#### Removal (G Model Diesel)

1. Disconnect batteries.
2. Remove air cleaner intake (rotate snorkel up).
3. Remove fan shroud bolts.
4. Disconnect hood latch cable.
5. Remove windshield washer bottle.
6. Remove upper shroud.
7. For installation, reverse removal procedures.

#### WATER PUMP

##### Removal - L6

1. Disconnect battery negative cable at battery.
2. Drain cooling system.
3. Remove accessory drive belts.
4. Remove fan to water pump hub (or fan clutch to water pump hub) attaching bolts (or nuts) and remove fan and pulley.
5. Remove lower radiator hose and heater hose from water pump.
6. Remove water pump to block attaching bolts and remove water pump.
  - On some vehicles, the generator adjusting brace is retained by one of the water pump to block bolts. If necessary, loosen generator adjusting bolt to allow this brace to be moved away from pump to prevent removal interference.

##### Installation - L6

1. With clean sealing surfaces on both water pump and block, place new gasket on water pump, mount on block and retain with attaching bolts. Torque bolts to 15 lb. ft. (20 N·m).
  - If generator adjusting brace was moved, move to original position before torquing water pump bolts.
2. Install lower radiator hose and heater hose to pump.

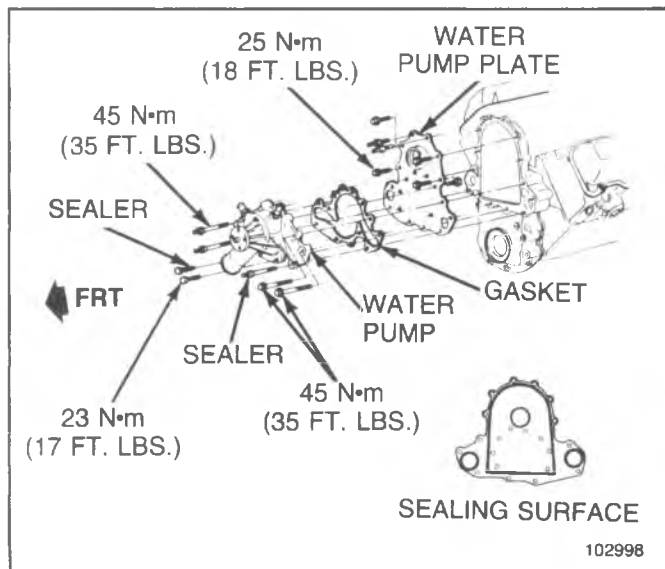

Fig. 6B-14--Water Pump 6.2L Diesel

3. Install water pump pulley and fan (or fan clutch assembly) on water pump hub. Torque retaining fasteners to 30 N·m (25 N·m if engine has fan clutch assembly).
4. Install accessory drive belts and adjust to specifications.
5. Connect battery negative cable.
6. Fill cooling system with an ethylene glycol anti-freeze and water mixture of 50/50%.
7. Start engine and run, with radiator cap removed, until radiator upper hose becomes hot (thermostat open).
8. With engine idling, add coolant to radiator until level reaches bottom of filler neck.
9. Install cap, making sure arrows line up with overflow tube.

**Removal - V8**

1. Disconnect battery negative cable at battery.
2. Drain cooling system.
3. Remove accessory drive belts.
4. Remove fan to water pump hub (or fan clutch to water pump hub) attaching bolts (or nuts) and remove fan and pulley.
5. Remove generator lower brace to water pump attaching bolts and swing brace down and out of way.
6. Remove generator upper brace to water pump attaching bolts.
7. Remove lower radiator hose and heater hose from water pump. On 7.4 liter engine, remove by-pass hose.
8. Remove water pump to block attaching bolts and remove pump.

**Installation - V8**

If installing new water pump, transfer heater hose fitting from old unit. On 7.4 liter engine, also transfer by-pass fitting.

1. With clean sealing surfaces on both water pump and block, place a 1/8" (3mm) bead of RTV, #1052366 or equivalent, along the sealing edge of each water pump leg. Place pump against block and retain with attaching bolts. Torque bolts to 20 N·m.
2. Attach lower radiator hose and heater hose to water pump. On 7.4 liter engine, install by-pass hose.
3. Attach generator upper and lower braces to water pump. Torque bolts to 35 N·m.
4. Install water pump pulley and fan (or fan clutch) to water pump hub. Torque fasteners to 30 N·m.
5. Install accessory drive belts. Adjust to specifications.
6. Connect battery negative cable.
7. Fill cooling system with an ethylene glycol anti-freeze and water mixture of 50/50%.
8. Start engine and run, with radiator cap removed, until radiator upper hose becomes hot (thermostat open).
9. With engine idling, add coolant to radiator until level reaches bottom of filler neck.
10. Install cap, making sure arrows line up with overflow tube.

**Removal - Diesel (Fig. 6B-14)**

1. Disconnect battery.
2. Remove fan.
3. Remove fan shroud.
4. Drain radiator.
5. If equipped with A/C, remove A/C hose bracket nuts.
6. Remove oil fill tube.
7. Remove generator pivot bolt and remove belt.
8. Remove generator lower bracket.
9. Remove power steering belt.
10. Remove power steering pump and lay aside.
11. Remove A/C belt if equipped.
12. Disconnect by-pass hose and lower radiator hose.
13. Remove water pump bolts.
14. Remove water pump plate and water pump.
15. If water pump gasket is to be repaired, remove plate attaching bolts to water pump and replace gasket.

**Installation**

At the time of installation, flanges must be free of oil. Apply anaerobic sealer 1052357 or equivalent as shown in Figure 6B-14. Sealer must be wet to the touch when bolts are torqued.

1. Attach water pump and plate assembly.
2. Connect by-pass hose and lower radiator hose.
3. Install power steering pump.
4. Install generator.
5. Install drive belts and adjust.
6. Install oil fill tube.
7. Install fan shroud.
8. Install fan.
9. Fill coolant to proper level.
10. Connect battery.
11. Seat engine and check for leaks.

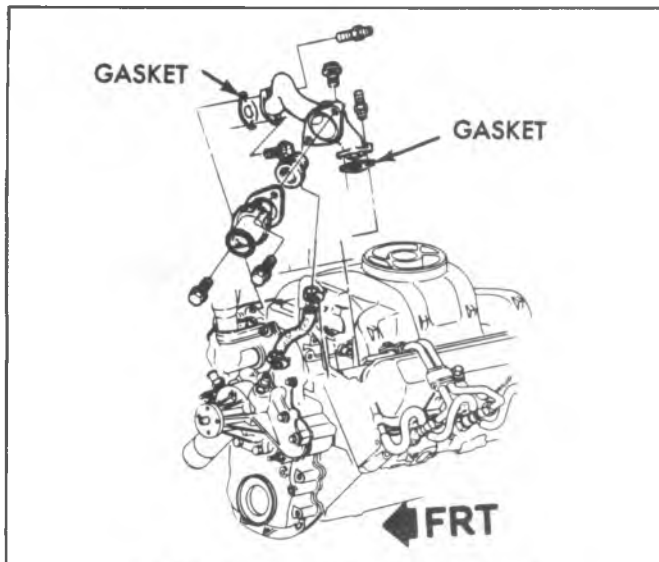

Fig. 6C6-15--Thermostat Housing (Diesel)

## THERMOSTAT

### Removal (Except 6.2L Diesel)

1. Disconnect battery negative cable at battery.
2. Drain cooling system until radiator coolant level is below thermostat.
3. Remove water outlet attaching bolts and remove outlet. Remove thermostat.

### Installation (Except 6.2L Diesel)

Prior to installing thermostat, make sure thermostat housing and coolant outlet sealing surfaces are clean.

1. Place a 1/8" (3mm) bead of RTV sealer, #1052366 or equivalent, all around the coolant outlet sealing surface on the thermostat housing.
2. Place thermostat in housing.
3. Install coolant outlet while RTV is still wet. Torque retaining bolts to 20 lb. ft. (27 N·m).
4. Connect battery negative cable.
5. Fill cooling system with an ethylene glycol anti-freeze and water mixture of 50/50%.
6. Start engine and run, with radiator cap removed, until radiator upper hose becomes hot (thermostat open).
7. With engine idling, add coolant to radiator until level reaches bottom of filler neck.
8. Install cap, making sure arrows line up with overflow tube.

### Removal/Installation (Diesel)

1. Disconnect batteries.
2. On G Van, remove upper fan shroud.
3. Drain coolant.
4. On G Van, remove engine oil dipstick tube brace and oil fill brace.
5. Remove housing bolts.
6. Remove upper hose.
7. For installation, reverse removal steps.

## THERMOSTAT HOUSING CROSSOVER

### CK Truck (Diesel)

#### Removal/Installation

1. Disconnect batteries.
2. Drain coolant.
3. Remove crankcase depression regulator valve.
4. Remove generator upper bracket.
5. Remove by-pass and upper radiator hoses and heater hose.
6. Remove crossover.
7. Prior to installation, clean gasket surfaces, replace gaskets and reverse removal procedures.

### G Van (Diesel)

#### Removal/Installation

1. Disconnect batteries.
2. Remove engine cover.
3. Remove air cleaner.
4. Remove air cleaner resonator and bracket.
5. Remove upper fan shroud.
6. Remove generator upper bracket.
7. Disconnect heater, radiator and bypass hoses at crossover.
8. Remove coolant crossover.
9. Prior to installation, clean gasket surfaces, replace gaskets and reverse removal procedures.

## RADIATOR (FIGS. 6B-16 THRU 6B-20)

### Removal (G & CK Series) Except 6.2L

1. Disconnect battery negative cable at battery.
2. Drain cooling system.
3. Remove radiator hoses from radiator.
4. Remove overflow hose from radiator.

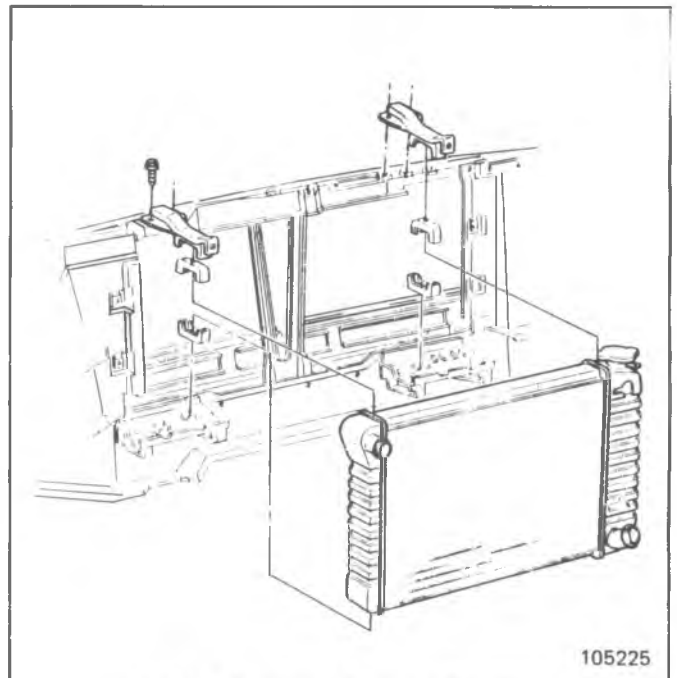

Fig. 6B-16--'G' Van Radiator Mounting



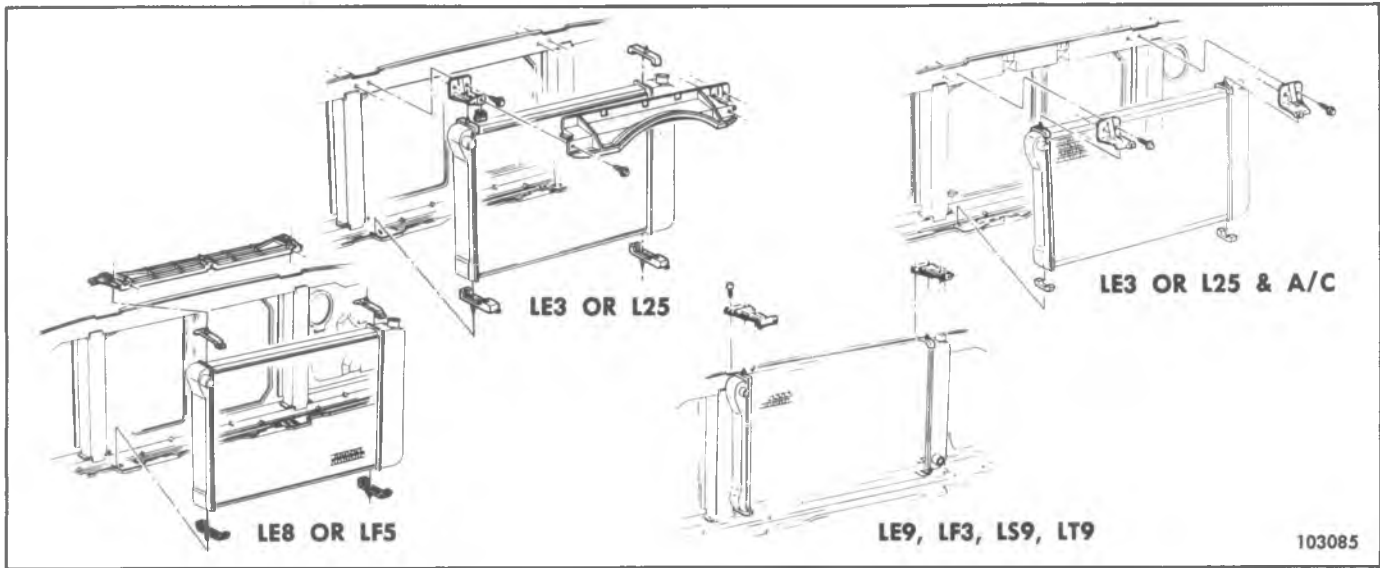

Fig. 6B-17--'CK' Radiator Mounting

5. Remove fan shroud, and disconnect transmission cooler lines.
6. Remove radiator to radiator support retainers (upper mounting panel on "CK") and remove radiator.

9. Install cap, making sure arrows line up with overflow tube.

**Installation**

1. Place radiator in vehicle and install radiator to radiator support retainers.
2. Install fan shroud.
3. Connect overflow hose to radiator.
4. Connect radiator hoses to radiator.
5. Connect battery negative cable.
6. Fill cooling system with an ethylene glycol anti-freeze and water mixture of 50/50%.
7. Start engine and run, with radiator cap removed, until radiator upper hose becomes hot (thermostat open).
8. With engine idling, add coolant to radiator until level reaches bottom of filler neck.

**RADIATOR 6.2L DIESEL**

**CK Truck**

**Removal/Installation**

1. Disconnect battery.
2. Drain coolant.
3. Remove fan shroud attaching screws.
4. Disconnect oil cooler lines.
5. Disconnect transmission cooler lines.
6. Disconnect radiator hoses.
7. Disconnect overflow hose.
8. Remove upper radiator supports.
9. Remove radiator.
10. For installation procedures, reverse removal procedures.

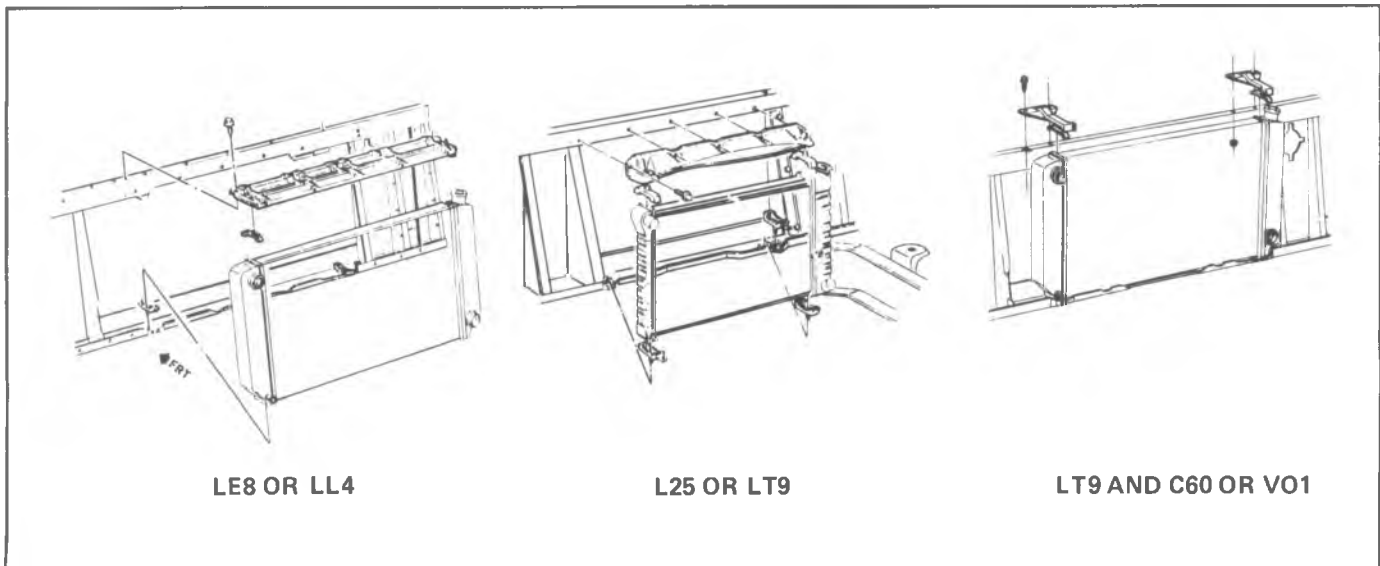

Fig. 6B-18--'P' (42) Radiator Mounting

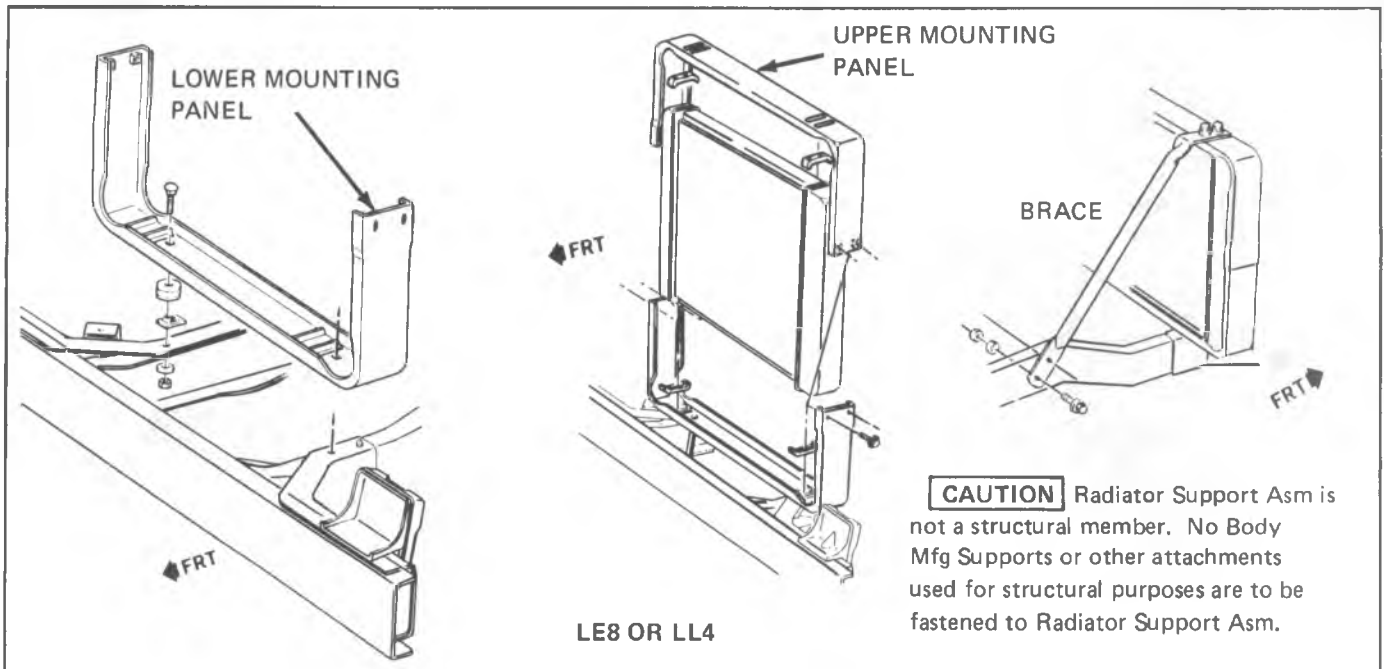

Fig. 6B-19--'P' (32) Radiator Mounting

## G Van

### Removal/Installation

1. Disconnect batteries.
2. Drain coolant.
3. Remove air intake snorkel.
4. Remove windshield washer bottle.
5. Disconnect hood release cable.
6. Remove upper fan shroud.
7. Disconnect upper radiator hose at radiator.
8. Disconnect transmission cooler lines.
9. Disconnect low coolant sensor.
10. Disconnect overflow hose.
11. Disconnect engine oil cooler lines.
12. Raise vehicle.
13. Disconnect lower radiator hose.
14. Lower vehicle.
15. Disconnect master cylinder from booster.
16. Remove radiator.
17. For installation, reverse removal procedures.

### FAN/FAN CLUTCH

#### Removal (All)

1. Remove battery negative cable at battery.
2. Remove radiator fan shroud as required.
3. Remove fan clutch hub-to-water pump hub attaching bolts or nuts, as applicable, and remove fan clutch assembly.
4. Remove fan from fan clutch hub.

#### Installation (All)

**CAUTION:** If a fan blade is bent or damaged in any way, no attempt should be made to repair and/or reuse the damaged part. A bent or damaged fan assembly should always be replaced with a new fan assembly.

**CAUTION:** It is essential that the fan assembly remain in proper balance. Balance cannot be assured once a fan assembly has been bent or damaged. A fan assembly that is not in proper balance could fail and fly apart during subsequent use, creating an extremely dangerous condition.

All mating surfaces (water pump hub and fan clutch hub) should be inspected for smoothness and reworked as necessary to eliminate burrs or other imperfections.

1. With fan on fan clutch hub, install fan clutch assembly to water pump hub. Torque attaching bolts, or nuts, to 20 lb. ft. (27 N·m). Be sure to align reference marks on both hubs.
2. Install radiator shroud as required.
3. Connect battery negative cable.

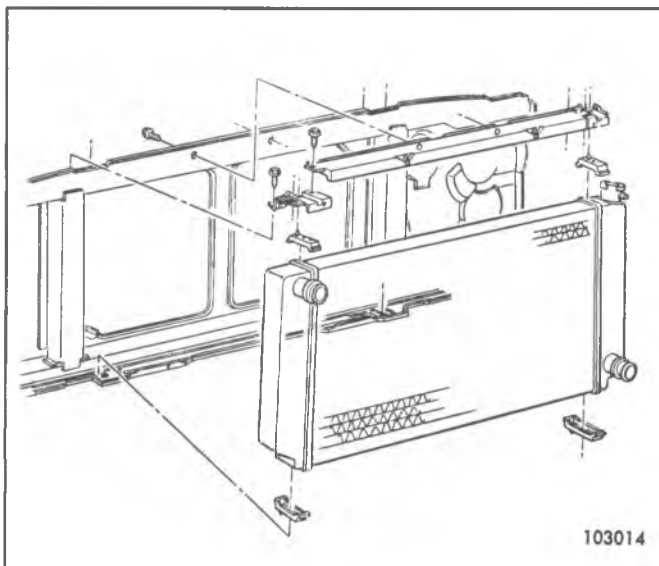

Fig. 6B-20--Radiator Mounting 6.2L Diesel CK Models

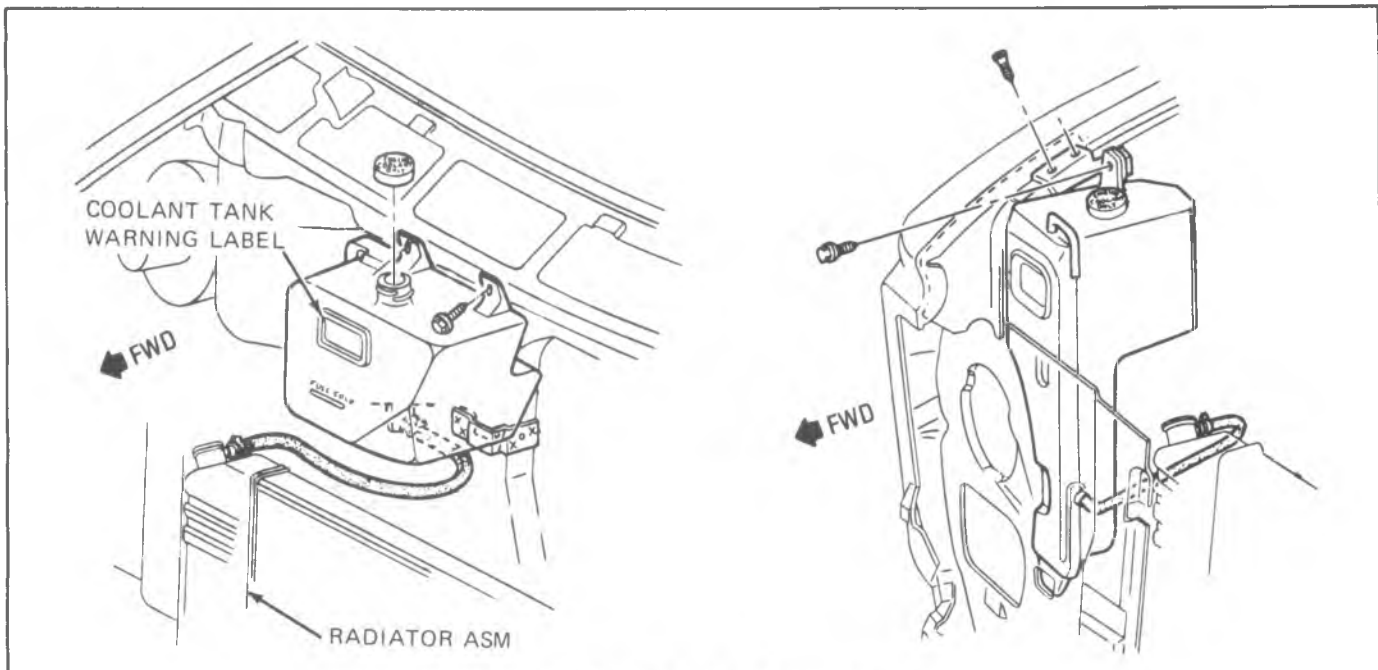

Fig. 6B-21--'G' Van Coolant Recovery Bottle

## COOLANT RECOVERY BOTTLE (FIGS. 6B-21 & 6B-22)

### Removal

1. Disconnect battery negative cable.
2. Remove coolant overflow hose from recovery bottle.
3. Remove recovery bottle retaining fasteners and remove bottle from vehicle.

### Installation

When installing coolant recovery bottle, make sure unit is clean and free from contamination. If needed, wash bottle with soap and water. Rinse thoroughly.

1. Install bottle in vehicle and retain with appropriate fasteners.
2. Connect coolant overflow hose to recovery bottle.

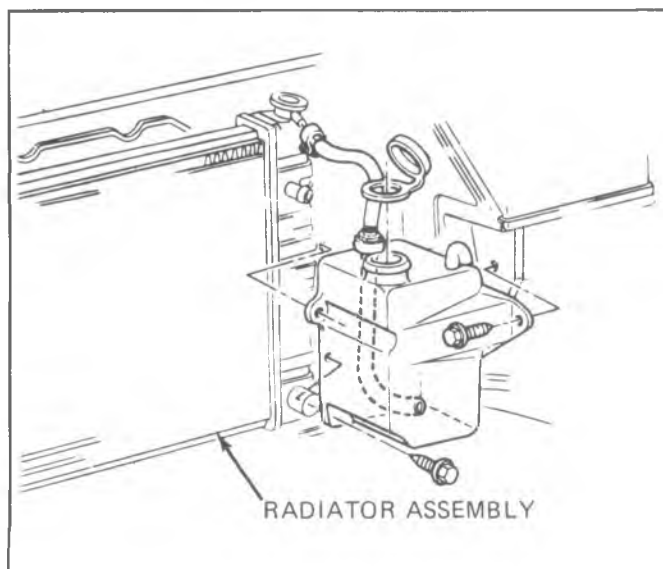

Fig. 6B-22--'CK' Series Coolant Recovery Bottle

3. Fill recovery bottle to appropriate mark with a 50/50 solution of water and ethylene glycol base anti-freeze.
4. Connect battery cable.

## ENGINE OIL COOLER

All truck vehicle lines have available, as either standard or optional equipment, oil coolers for the engine oil. For the location of these units, refer to figures 6B-23 & 6B-24.

## COOLANT LEVEL INDICATOR

### Indicator Lamp Will Not Illuminate

1. Turn ignition switch to **CRANK** position. If lamp illuminates, lamp is ok and connector is properly installed on module, go to Step 2. If lamp does not illuminate, check bulb, socket, wiring between socket and module connector, and connector on module. Replace or repair as required.
2. Turn ignition switch to **ON** position and disconnect electrical lead at coolant level sensor on radiator. If lamp fails to illuminate, check wiring between coolant level sensor connector and module for short circuit to ground. If ok, replace module.

### Indicator Lamp Remains Illuminated

1. Turn ignition switch to **ON** position and check coolant level. Add coolant if necessary. If indicator lamp remains illuminated, go to Step 2.
2. Disconnect electrical lead at coolant level sensor on radiator. Use a jumper wire and "G" electrical connector. If lamp does not illuminate, replace sensor. If lamp remains illuminated, connect electrical lead and go to Step 3.
3. Check for an open circuit between sensor and module. If an open circuit is found, repair. If no open circuit is found, replace module.

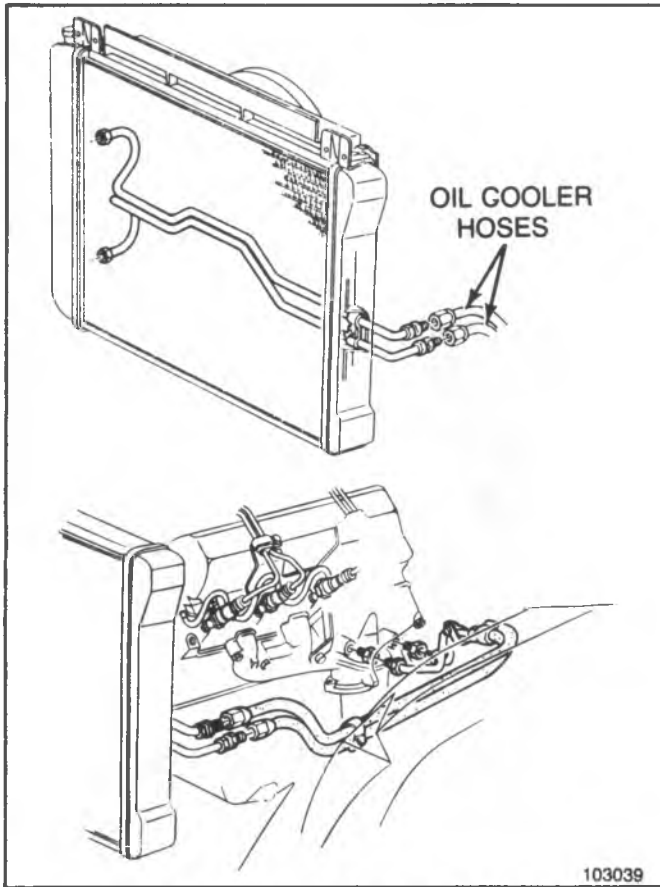

Fig. 6B-23-Engine Oil Cooler - 6.2L Diesel

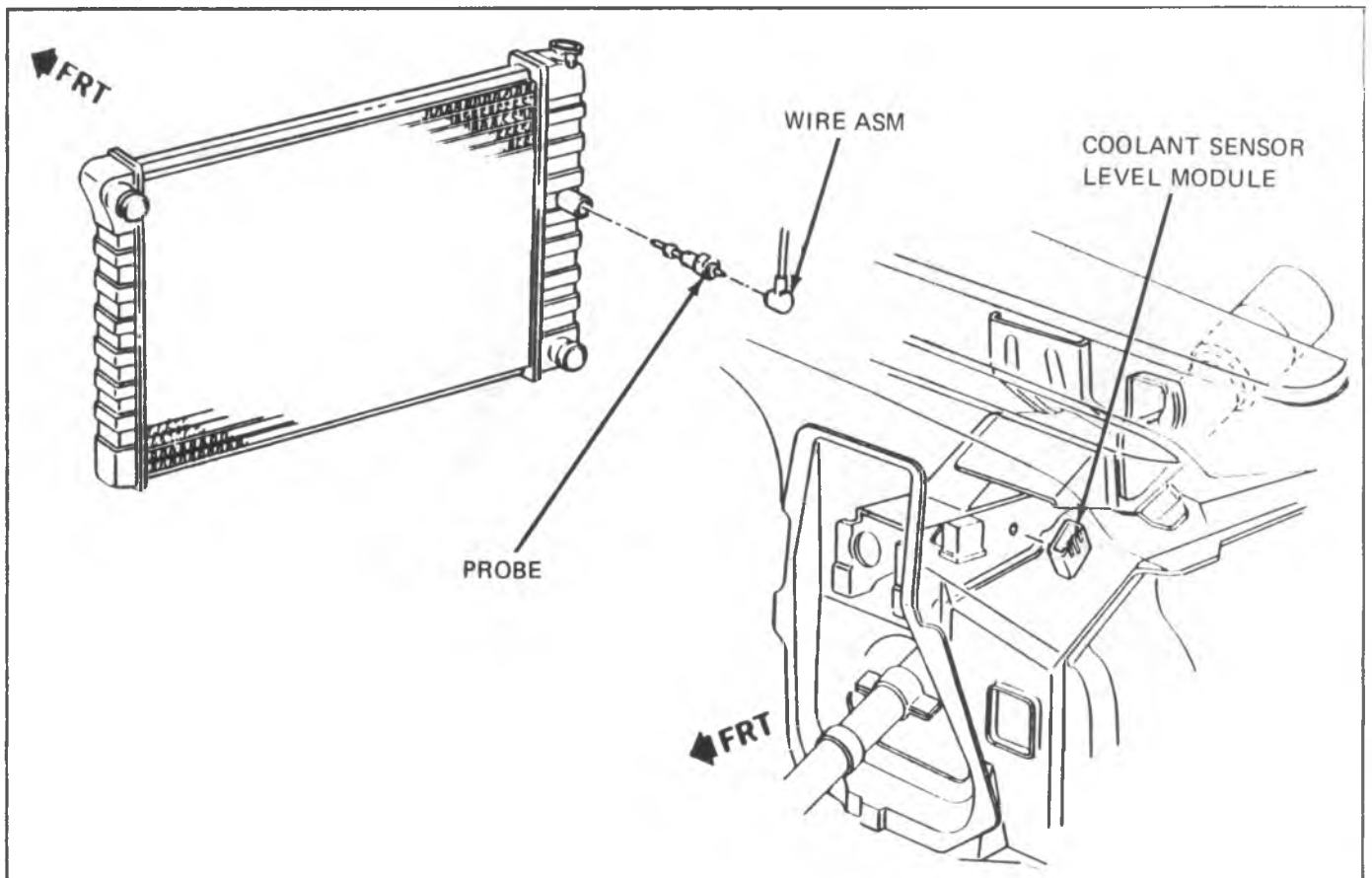
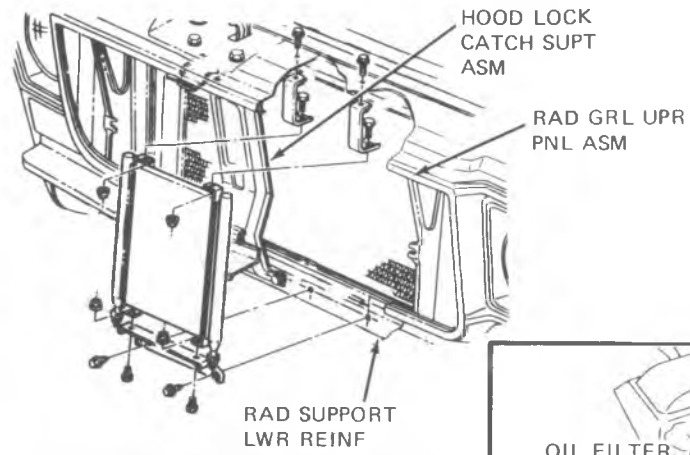
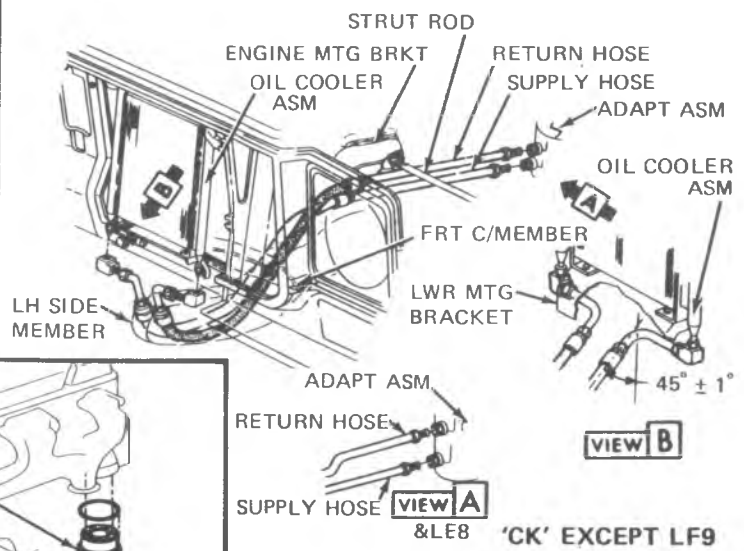

Fig. 6B-24 — Coolant Level Indicator



'CK' EXCEPT LF9



'CK' EXCEPT LF9

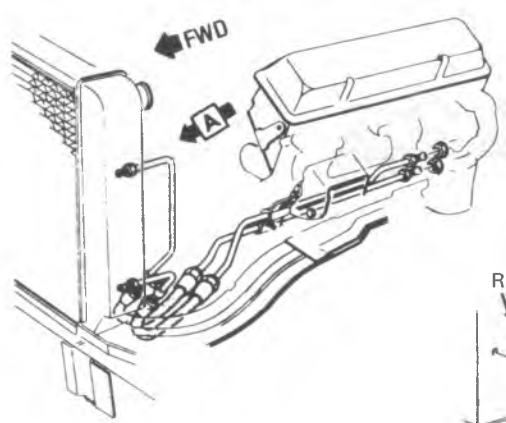
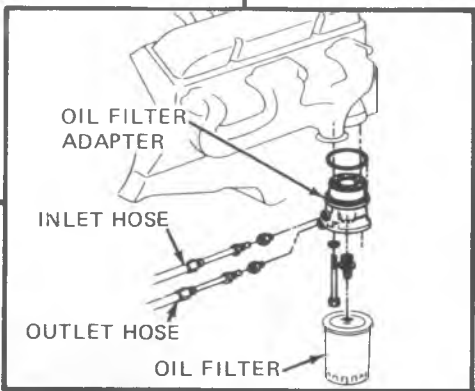

'G' VAN

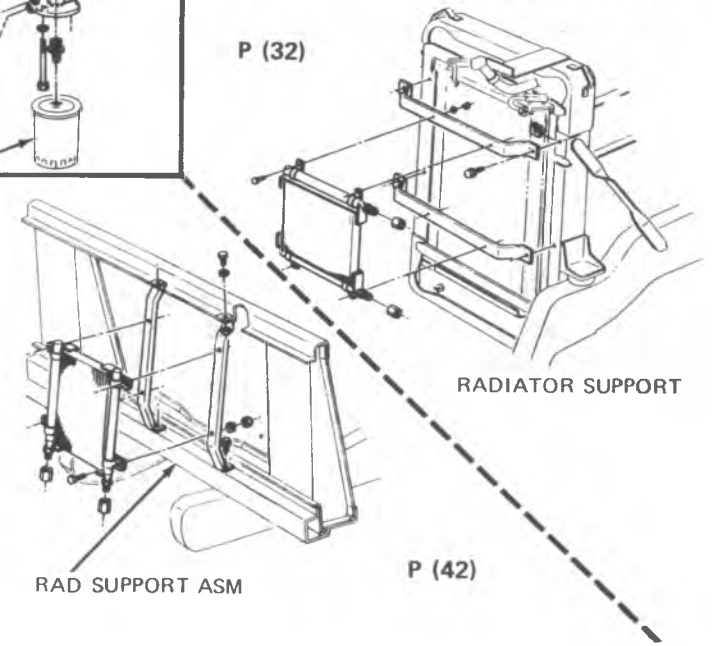
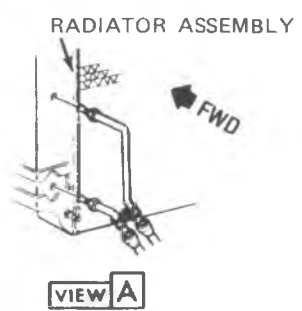

Fig. 6B-25 — Engine Oil Coolers Except Diesel

## SECTION 6C

### ENGINE FUEL - GASOLINE

#### CONTENTS

|                                   |       |                                   |        |
|-----------------------------------|-------|-----------------------------------|--------|
| General.....                      | 6C-1  | Accelerator Controls .....        | 6C-21  |
| Diagnosis                         |       | Model E4ME Carburetor.....        | 6C1-1  |
| Carburetor Diagnosis .....        | 6C-1  | Model E2SE Carburetor .....       | 6C3-1  |
| Evaporative Control System.....   | 6C-10 | Model 1ME Carburetor .....        | 6C7-1  |
| Fuel Tank.....                    | 6C-11 | Model 2SE Carburetor.....         | 6C9-1  |
| Fuel Filter .....                 | 6C-12 | Model M4ME/M4MC Carburetor .....  | 6C10-1 |
| Fuel Pump.....                    | 6C-12 | Specifications .....              | 6C-24  |
| Fuel Tank.....                    | 6C-14 | Angle to Decimal Conversion ..... | 6C-25  |
| Auxiliary Fuel Tank Control ..... | 6C-18 | Special Tools.....                | 6C-25  |
| Fuel Lines .....                  | 6C-18 |                                   |        |
| Evaporative Control System.....   | 6C-19 |                                   |        |

#### GENERAL

ALL NEW GM VEHICLES ARE CERTIFIED BY THE UNITED STATES ENVIRONMENTAL PROTECTION AGENCY AS CONFORMING TO THE REQUIREMENTS OF THE REGULATIONS FOR THE CONTROL OF AIR POLLUTION FROM NEW MOTOR VEHICLES. THIS CERTIFICATION IS CONTINGENT ON CERTAIN ADJUSTMENTS BEING SET TO FACTORY STANDARDS. IN MOST CASES, THESE ADJUSTMENT POINTS EITHER HAVE BEEN PERMANENTLY SEALED AND/OR MADE INACCESSIBLE TO PREVENT INDISCRIMINATE OR ROUTINE ADJUSTMENT IN THE FIELD. FOR THIS REASON, THE FACTORY PROCEDURE FOR TEMPORARILY REMOVING PLUGS, CAP, ETC., FOR PURPOSES OF SERVICING THE PRODUCT, MUST BE STRICTLY FOLLOWED AND, WHEREVER PRACTICABLE, RETURNED TO THE ORIGINAL INTENT OF THE DESIGN.

Typical illustrations and procedures are used except where specific illustrations or procedures are necessary to clarify the operation.

**NOTICE:** All gasoline engines require the use of unleaded fuel only. Use of leaded and/or low lead fuel

can result in engine damage and reduce the effectiveness of the Emission Control Systems.

## CARBURETOR DIAGNOSIS

The following diagnostic procedures are for carburetor related problems and their effects on car performance. Other systems of the car can also cause similar problems and should be checked when listed on the chart. The problem areas described are:

1. Engine cranks normally. Will not start.
2. Engine starts and stalls.
3. Engine starts hard.
4. Engine idles abnormally and/or stalls.
5. Inconsistent engine idle speeds.
6. Engine diesels (after-run) upon shut off.
7. Engine hesitates on acceleration.
8. Engine has less than normal power at low speeds.
9. Engine has less than normal power on heavy acceleration or at high speed.
10. Engine surges.
11. Poor gas mileage.

| CONDITION   | POSSIBLE CAUSE  | CORRECTION  |
|---|---|---|
| <p>Engine Cranks Normally<br/>- Will Not Start.</p> | <p>Improper starting procedure used.</p><br><br><p>Choke valve not operating properly.</p><br><br><br><br><br><br><br><br><br><br><p>No fuel in carburetor.</p><br><br><br><br><br><br><br><br><br><br><p>Engine flooded. To check for flooding, remove the air cleaner with the engine immediately shut off and look into the carburetor bores. Fuel will be dripping off nozzles.</p> | <p>Check with the customer to determine if proper starting procedure is used, as outlined in the Owner's Manual.</p><br><br><p>Adjust the choke thermostatic coil to specification. Check the choke valve and/or linkage as necessary. Replace parts if defective. If caused by foreign material and gum, clean with suitable non-oil base solvent.</p> <p>NOTE: After any choke system work, check choke vacuum break settings and correct as necessary.</p><br><br><p>Remove fuel line at carburetor. Connect hose to fuel line and run into metal container. Remove the wire from the "bat" terminal of the distributor. Crank over engine - if there is no fuel discharge from the fuel line, test fuel pump as outlined in Section 6. If fuel supply is okay, check the following:</p> <ol style="list-style-type: none"> <li>a. Inspect fuel inlet filter. If plugged, replace.</li> <li>b. If fuel filter is okay, remove air horn and check for a bind in the float mechanism or a sticking inlet needle. If okay, adjust float as specified.</li> </ol> <p>Remove the air horn.</p><br><br><p>Check fuel inlet needle and seat for proper seal. If a needle and seat tester is not available, apply vacuum to the needle seat with needle installed. If the needle is leaking, replace.</p><br><br><p>Check float for free movement, bent float hanger or binds in the float arm.</p><br><br><p>If foreign material is in fuel system, clean the system and replace fuel filters as necessary. If excessive foreign material is found, completely disassemble and clean.</p> |

Fig. 6C-1--Carburetor Diagnosis - 1 of 8

## CARBURETOR DIAGNOSIS CONT'D.

| CONDITION                                    | POSSIBLE CAUSE  | CORRECTION   |
|--|---|--|
| <p>Engine Starts — Will Not Keep Running</p> | <p>Fuel pump.</p>   | <p>Check fuel pump pressure and volume, replace if necessary. See FUEL SYSTEM DIAGNOSIS, Section 6.</p>  |
|  | <p>Idle speed.</p> <p>Choke heater system malfunctioning (may cause loading).</p>   | <p>Adjust idle to specifications.</p> <p>Check vacuum supply at hot air inlet to choke housing. Should be not less than manifold vacuum minus 3" Hg. with engine running at idle. (Exc. IMV) Check wiring.</p> <p>Check for plugged, restricted, or broken heat tubes.</p> <p>Check routing of all hot air parts.</p>  |
| <p>Engine Starts Hard (Crankes Normally)</p> | <p>Loose, broken or incorrect vacuum hose routing.</p>                              | <p>Check condition and routing of all vacuum hoses — correct as necessary.</p>   |
|  | <p>Engine does not have enough fast idle speed when cold.</p>                       | <p>Check for free movement of fast idle cam. Clean and/or realign as necessary.</p>  |
|  | <p>Choke vacuum break units are not adjusted to specification or are defective.</p> | <p>Adjust both vacuum break assemblies to specification. If adjusted okay, check the vacuum break units for proper operation as follows:</p> <p>To check the vacuum break units, apply a constant vacuum source of at least 10" Hg., plungers should slowly move inward and hold vacuum. If not, replace the unit.</p> <p>Always check the fast idle cam adjustment when adjusting vacuum break units.</p> |
|  | <p>Choke valve sticking and/or binding.</p>   | <p>Clean and align linkage or replace if necessary. Readjust all choke settings, see Section 6M, if part replacement or realignment is necessary.</p>  |
|  | <p>Insufficient fuel in carburetor.</p>   | <p>Check fuel pump pressure and volume.</p> <p>Check for partially plugged fuel inlet filter. Replace if contaminated.</p> <p>Check the float level adjustment for binding condition. Adjust as specified.</p>   |
| <p>Engine Starts Hard (Crankes Normally)</p> | <p>Loose, broken or incorrect vacuum hose routing.</p>                              | <p>Check condition and routing of all vacuum hoses — correct as necessary. See Section 6E.</p>   |
|  | <p>Incorrect starting procedure.</p>  | <p>Check to be sure customer is using the starting procedure outlined in Owner's Manual.</p>   |

Fig. 6C-2--Carburetor Diagnosis - 2 of 8



## CARBURETOR DIAGNOSIS CONT'D.

| CONDITION  | POSSIBLE CAUSE  | CORRECTION  |
|--|---|---|
| <p>Engine Starts Hard<br/>(Crankes Normally)<br/>(Continued)</p> | <p>Malfunction in accelerator pump system.</p> <p>Choke valve not closing.</p> <p>Vacuum breaks misadjusted or malfunctioning.</p> <p>Insufficient fuel in bowl.</p> <p>Flooding.</p>   | <p>Check accelerator pump adjustment and operation.</p> <p>Check pump discharge ball for sticking or leakage.</p> <p>Adjust choke thermostatic coil. Check choke valve and linkage for binds and alignment. Clean and repair or replace as necessary.</p> <p>Check for adjustment and function of vacuum breaks. Correct as necessary.</p> <p>Check fuel pump pressure and volume. Check for partially plugged fuel inlet filter. Replace if dirty. Check float mechanism. Adjust as specified.</p> <p>Check float and needle and seat for proper operation.</p>  |
| <p>Engine Idles Abnormally<br/>(Too fast or too slow)</p>        | <p>Slow engine cranking speed.</p> <p>Incorrect idle speed.</p> <p>Air leaks into carburetor bores beneath throttle valves, manifold leaks, or vacuum hoses disconnected or installed improperly.</p> <p>Clogged or malfunctioning PCV system.</p> <p>Carburetor flooding.</p> <p>Check by using procedure outlined under "Engine Flooded".</p> | <p>Refer to starting circuit diagnosis. Section 6D.</p> <p>Reset idle speed per instructions on underhood label.</p> <p>Check all vacuum hoses and restrictors leading into the manifold or carburetor base for leaks or being disconnected. Install or replace as necessary.</p> <p>Torque carburetor to manifold bolts to 10 ft. lbs. Using a pressure oil can, spray light oil or kerosene around manifold to head surfaces and carburetor throttle body.<br/>NOTE: Do not spray at throttle shaft ends.<br/>If engine RPM changes, tighten or replace the carburetor or manifold gaskets as necessary.</p> <p>Check PCV system. Clean and/or replace as necessary.</p> <p>Remove air horn and check float adjustments.</p> <p>Check float needle and seat for proper seal. If a needle and seat tester is not available, apply vacuum to the needle seat with needle installed. If the needle is leaking or damaged, replace.</p> |

## CARBURETOR DIAGNOSIS CONT'D.

| CONDITION   | POSSIBLE CAUSE  | CORRECTION   |   |
|---|---|--|---|
| <p>Engine Idles Abnormally<br/>(Too fast or too slow)<br/>(Continued)</p> |   | <p>Check float for free movement. Check for bent float hanger or binds in the float arm.</p> <p>If foreign material is found in the carburetor, clean the fuel system and carburetor. Replace fuel filter as necessary.</p> <p>Replace as necessary.</p> <p>Clean carburetor, see Section 6C1.</p> <p>Readjust per specified procedure. See Section 6C1.</p> <p>Check solenoid and wiring.</p> |   |
|   | Restricted air cleaner element.   |  |   |
|   | Idle system plugged or restricted.  |  |   |
|   | Incorrect idle mixture adjustment.  |  |   |
|   | Defective idle stop solenoid, idle speed-up solenoid or wiring.           |  |   |
|   | Throttle blades or linkage sticking and/or binding.                       |  |   |
|   |   |  | Check throttle linkage and throttle blades (primary and secondary) for smooth and free operation. Correct problem areas.  |
|   |   |  | Check condition and routing of all vacuum hoses. Correct as necessary.  |
|   |   |  | Reset idle speed per instructions on label in engine compartment.   |
|   |   |  | Check for correct operation of idle solenoid. Check for sticky or binding solenoid.   |
| <p>Engine Diesels (After Run) upon Shut Off</p>                           | Loose, broken or improperly routed vacuum hoses.                          |  |   |
|   | Incorrect idle speed.   |  |   |
|   | Malfunction of idle stop solenoid, idle speed-up solenoid or dashpot.     |  |   |
|   | Fast idle cam not fully off.  |  |   |
|   |   |  | Check fast idle cam for freedom of operation. Clean, repair, or adjust as required. Check choke heated air tubes for routing, fittings being tight or tubes plugged. Check choke linkage for binding. Clean and correct as necessary. |
|   | Excessively lean condition caused by maladjusted carburetor idle mixture. |  |   |
|   | Ignition timing retarded.   |  |   |
|   |   | Adjust carburetor idle mixture as described in Section 6C1.  |   |
|   |   | Set to specifications.   |   |
| <p>Engine Hesitates On Acceleration</p>                                   | Loose, broken or incorrect vacuum hose routing                            |  |   |
|   | Accelerator pump not adjusted to specification or inoperative.            |  |   |
|   | Inoperative accelerator pump system.                                      |  |   |
|   |   |  | Check condition and routing of all vacuum hoses — correct or replace.   |
|   |   | Adjust accelerator pump, replace.  |   |
|   |   | Remove air horn and check pump cup. If cracked, scored or distorted, replace the pump plunger.   |   |

Fig. 6C-4—Carburetor Diagnosis - 4 of 8

## CARBURETOR DIAGNOSIS CONT'D.

| CONDITION   | POSSIBLE CAUSE  | CORRECTION   |
|---|---|--|
| <p>Engine Hesitates On Acceleration<br/>(Continued)</p>           | <p>NOTE: A quick check of the pump system can be made as follows: With the engine off, look into the carburetor bores and observe pump nozzles while quickly opening throttle lever. A full stream of fuel should emit from each pump nozzle.</p> <p>Foreign matter in pump passages.</p> <p>Float level too low.</p> <p>Front vacuum break diaphragm not functioning properly.</p> <p>Air valve malfunction.</p> <p>Power enrichment system not operating correctly.</p> <p>Inoperative air cleaner heated air control.</p> <p>Fuel filter dirty or plugged.</p> <p>Distributor vacuum or mechanical advance malfunctioning.</p> <p>Timing not to specifications.</p> <p>Choke coil misadjusted (cold operation.)</p> <p>EGR valve stuck open.</p> | <p>Check the pump discharge ball for proper seating and location.</p> <p>Clean and blow out with compressed air.</p> <p>Check and reset float level to specification.</p> <p>Check adjustment and operation of vacuum break diaphragm.</p> <p>Check operation of secondary air valve. Check spring tension adjustment.</p> <p>Check for binding or stuck power piston(s) — correct as necessary.</p> <p>Check operation of thermostatic air cleaner system.</p> <p>Replace filter and clean fuel system as necessary.</p> <p>Check for proper operation.</p> <p>Adjust to specifications.</p> <p>Adjust to specifications.</p> <p>Inspect and clean EGR valve.</p> |
| <p>Engine Has Less Than Normal Power At Normal Accelerations.</p> | <p>Loose, broken or incorrect vacuum hose routing.</p> <p>Clogged or defective PCV system.</p> <p>Choke sticking.</p> <p>Clogged or inoperative power system.</p>   | <p>Check condition and routing of all vacuum hoses.</p> <p>Clean or replace as necessary.</p> <p>Check complete choke system for sticking or binding. Clean and realign as necessary. Check adjustment of choke thermostatic coil.</p> <p>Check connections and operation of choke hot air system.</p> <p>Check jets and channels for plugging; clean and blow out passages.</p> <p>Remove air horn and check for free operation of power pistons.</p>   |

Fig. 6C-5--Carburetor Diagnosis - 5 of 8

## CARBURETOR DIAGNOSIS CONT'D.

| CONDITION  | POSSIBLE CAUSE  | CORRECTION   |
|--|---|--|
| <p><b>Engine Has Less Than Normal Power At Normal Accelerations. (Continued)</b></p> | <p>Air cleaner temperature regulation improper.</p> <p>Transmission malfunction.</p> <p>Ignition system malfunction.</p> <p>Exhaust system.</p>   | <p>Check regulation and operation of air cleaner system.</p> <p>Refer to transmission diagnosis.</p> <p>Check ignition system. See Section 6D. Refer to H.E.I. diagnosis.</p> <p>Check for restrictions. Correct as required.</p>  |
| <p><b>Less Than Normal Power On Heavy Acceleration Or At High Speed</b></p>          | <p>Carburetor throttle valves not going wide open. Turn off engine and check by pushing accelerator pedal to floor.</p> <p>Secondary throttle lockout not allowing secondaries to open.</p> <p>Spark plugs fouled, incorrect gap.</p> <p>Plugged air cleaner element.</p> <p>Air valve malfunction. (Where applicable)</p> <p>Plugged fuel inlet filter.</p> <p>Insufficient fuel to carburetor.</p> <p>Power enrichment system not operating correctly.</p> <p>Choke closed or partially closed.</p> <p>Float level too low.</p> | <p>Correct throttle linkage to obtain wide open throttle in carburetor.</p> <p>Check for binding or sticking lockout lever.</p> <p>Check for free movement of fast idle cam.</p> <p>Check choke heated air system for proper and tight connections plus flow through system.</p> <p>Check adjustment of choke thermostatic coil.</p> <p>Make necessary corrections and adjustments.</p> <p>Clean, regap, or replace plugs.</p> <p>Replace element.</p> <p>Check for free operation of air valve.</p> <p>Check spring tension adjustment. Make necessary adjustments and corrections.</p> <p>Replace with a new filter element.</p> <p>Check fuel pump and system, run pressure and volume test. See FUEL SYSTEM DIAGNOSIS, Section 6.</p> <p>Remove the air horn and check for free operation of both power piston(s), clean and correct as necessary.</p> <p>Free choke valve or linkage.</p> <p>Check for loose jets.</p> <p>Check and reset float level to specification.</p> |

Fig. 6C-6--Carburetor Diagnosis - 6 of 8

## CARBURETOR DIAGNOSIS CONT'D.

| CONDITION  | POSSIBLE CAUSE                 | CORRECTION  |   |
|--|--------------------------------|---|---|
| Less Than Normal Power<br>On Heavy Acceleration<br>Or At High Speed<br>(Continued) | Transmission malfunction.      | Refer to transmission diagnosis.  |   |
|  | Ignition system malfunction.   | Check ignition system. See Section 6D.  |   |
|  | Fuel metering jets restricted. | If the fuel metering jets are restricted and an excessive amount of foreign material is found in the fuel bowl, the carburetor should be completely disassembled and cleaned. |   |
|  | Fuel pump.                     | Check fuel pump pressure and volume, inspect lines for leaks and restrictions. See FUEL SYSTEM DIAGNOSIS, Section 6.  |   |
|  | Exhaust system.                | Check for restrictions. Correct as required.  |   |
|  | Engine Surges                  | Loose, broken or incorrect vacuum hose routing.   | Check condition and routing of all vacuum hoses. Correct as necessary.  |
|  |                                | PCV system clogged or malfunctioning.   | Check PCV system. Clean or replace as necessary.  |
|  |                                | Loose carburetor, EGR or intake manifold bolts and/or leaking gaskets.  | Torque carburetor to manifold bolts to 10 ft. lbs. Using a pressure oil can, spray light oil or kerosene around manifold to head mounting surface and carburetor base. If engine RPM changes, tighten or replace the carburetor or manifold gaskets as necessary. Check EGR mounting bolt torque. |
|  |                                | Low or erratic fuel pump pressure.  | Check fuel delivery and pressure.   |
|  |                                | Contaminated fuel.  | Check for contaminants in fuel. Clean system if necessary.  |
| Fuel filter plugged.   |                                | Check and replace as necessary.   |   |
| Float level too low.   |                                | Check and reset float level to specification.   |   |
| Malfunctioning float and/or needle and seat.                                       |                                | Check operation of system. Repair or replace as necessary.  |   |
| Power piston stuck or binding.   |                                | Check for free movement of power piston(s). Clean and correct as necessary.   |   |
| Fuel jets or passages plugged or restricted.                                       |                                | Clean and blow out with compressed air.   |   |
| Poor Gas Mileage   | Ignition system malfunction.   | Check ignition system. See Section 6D.  |   |
|  | Exhaust system.                | Check for restrictions. Correct as necessary.   |   |
|  | Customer driving habits.       | Run mileage test with customer driving if possible. Make sure car has 2000-3000 miles for the "break-in" period.  |   |

Fig. 6C-7--Carburetor Diagnosis - 7 of 8

## CARBURETOR DIAGNOSIS CONT'D.

| CONDITION  | POSSIBLE CAUSE  | CORRECTION   |
|--|---|--|
| <p>Poor Gas Mileage<br/>(Continued)</p>  | <p>Loose, broken or improperly routed vacuum hoses.</p> <p>Engine in need of service.</p>   | <p>Check condition of all vacuum hose routings. Correct as necessary.</p> <p>Check engine compression, examine spark plugs; if fouled or improperly gapped, clean and regap or replace. Check ignition wire condition and check and reset ignition timing. Replace air cleaner element if dirty. Check for restricted exhaust system and intake manifold for leakage. Check carburetor mounting bolt torque. Check vacuum and mechanical advance.</p>  |
| <p>Poor Gas Mileage and/or Black Smoke from Tail Pipe</p>                          | <p>Fuel leaks.</p> <p>High fuel level in carburetor.</p>  | <p>Check fuel tank, fuel lines and fuel pump for any fuel leakage.</p> <p>Check fuel inlet needle and seat for proper seal. Test, using suction from a vacuum source. If needle is leaking, replace.</p> <p>Check for loaded float. Reset float level to specification.</p> <p>If excessive foreign material is present in the carburetor bowl, the carburetor should be cleaned.</p>  |
| <p>Car feels like it is running out of gas — surging occurs in mid-speed range</p> | <p>Power system in carburetor not functioning properly. Power piston(s) sticking or metering rods out of jets.</p> <p>Choke system.</p> <p>Plugged air cleaner element.</p> <p>Exhaust system.</p> <p>Low tire pressure or incorrect tire size.<br/>Evaporative emission canistor<br/>Transmission malfunction or in wrong gear.<br/>Plugged fuel filters.</p> <p>Faulty fuel pump.</p> <p>Foreign material in fuel system or kinked fuel pipes or hoses.</p> | <p>Remove air horn and check for free movement of power piston(s). Clean and correct as necessary.</p> <p>Check choke heated air tubes for routing and/or plugging which would restrict hot air flow to choke housing. Check choke linkage for binding. Clean or repair as required. Check adjustment of thermostatic coil. Readjust to specification as required. Check electric choke wiring.<br/>Replace element.</p> <p>Check for restrictions. Correct as required.</p> <p>Inflate tires to specifications and use correct size tires.<br/>See evaporative section (Dagnosis)<br/>Refer to transmission diagnosis.</p> <p>Remove and replace filters.</p> <p>Perform fuel pump test.<br/>Remove and replace fuel pump as required.</p> <p>Inspect pipes, and hoses for kinks and bends, blow out to check for plugging.<br/>Remove and replace as required.</p> |

Fig. 6C-8--Carburetor Diagnosis - 8 of 8

| CONDITION  | POSSIBLE CAUSE   | CORRECTION  |
|--|--|---|
| <p>Evidence of fuel loss or fuel vapor odor</p> <p>A) From area of fuel tank or fuel cap - Perform pressure check to determine possible causes</p> | <ol style="list-style-type: none"> <li>1. Leaking or plugged fuel or EVAP hoses</li> <li>2. Leaking fuel cap</li> <li>3. Leaking fuel filler neck</li> <li>4. Fuel filler neck gasket surface nicked, burred, or dented</li> <li>5. Leaking sending unit or gasket</li> <li>6. Leaking tank switch unit (Dual tank system)</li> <li>7. Inoperative tank switch unit (Dual tank system)</li> <li>8. Plugged or inoperative tank pressure control valve</li> </ol>   | <ol style="list-style-type: none"> <li>1. Repair or replace hoses as necessary</li> <li>2. Repair or replace cap as necessary</li> <li>3. Repair or replace as necessary</li> <li>4. Repair or replace as necessary</li> <li>5. Repair or replace as necessary</li> <li>6. Replace unit</li> <li>7. Replace unit</li> <li>8. Repair or replace as necessary</li> </ol>  |
| <p>B) From under hood - Perform pressure check to determine possible causes</p>  | <ol style="list-style-type: none"> <li>1. Liquid fuel leaking from fuel lines, fuel pump or carburetor</li> <li>2. Cracked or damaged canisters</li> <li>3. Inoperative bowl vent valve (see Bowl Vent Check Procedures)</li> <li>4. Inoperative purge valve (see Purge Valve Check Procedures)</li> <li>5. Disconnected, misrouted, kinked, deteriorated or damaged vapor hoses or control hoses</li> <li>6. Bowl vent hose misrouted</li> <li>7. Air cleaner or air cleaner gasket improperly seated</li> <li>8. Leaking or inoperative tank pressure control valve</li> </ol> | <ol style="list-style-type: none"> <li>1. Tighten fuel lines, repair or replace fuel pump or carburetor as necessary</li> <li>2. Repair or replace canisters as necessary</li> <li>3. Repair or replace hoses<br/>Replace canister</li> <li>4. Repair or replace hoses<br/>Replace canister</li> <li>5. Check for proper connections, and check routing as well as condition. Correct as necessary</li> <li>6. Reroute hose without low spots</li> <li>7. Reinstall air cleaner and/or replace gasket</li> <li>8. Repair or replace as necessary</li> </ol> |
| <p>Poor idle or driveability or driveability slugging</p>  | <ol style="list-style-type: none"> <li>1. Inoperative purge valve (see Purge Valve Check Procedures)</li> <li>2. Inoperative bowl vent valve (see Bowl Vent Check Procedures)</li> <li>3. Vacuum leak at tank pressure control valve</li> </ol>  | <ol style="list-style-type: none"> <li>1. Replace or repair hoses<br/>Replace canister</li> <li>2. Repair or replace hoses<br/>Replace canister</li> <li>3. Repair or replace hoses and/or valve</li> </ol>   |
| <p>Collapsed fuel tank (Loss of tank capacity)</p>   | <ol style="list-style-type: none"> <li>1. Plugged or pinched vapor pipe or hoses and defective cap</li> <li>2. Canister filter plugged and defective cap</li> <li>3. Plugged or ruptured diaphragm in tank pressure control valve and defective cap</li> </ol>   | <ol style="list-style-type: none"> <li>1. Check all lines from tank to canister and replace cap</li> <li>2. Replace filter in canister and cap</li> <li>3. Replace tank pressure control valve and cap</li> </ol>   |

Fig. 6C-9--Evaporative Control System

## DIAGNOSIS FUEL TANK

| CONDITION           | POSSIBLE CAUSE  | CORRECTION  |
|---------------------|---|---|
| Gasoline Odor       | <ol style="list-style-type: none"> <li>1. Tank overfilled.</li> <li>2. Fuel feed line leaking.</li> <li>3. Leak in fuel tank.</li> <li>4. Disconnected fuel vapor pipe or hoses.</li> <li>6. Faulty fill cap or tank neck.</li> </ol> | <p>Do not "pack" tank. Fill to automatic shut-off.<br/>Correct as required.</p> <p>Purge tank and repair or replace tank as required.<br/>Connect pipe or hoses as required.</p> <p>Install new cap or tank neck as required.</p> |
| Collapsed Fuel Tank | <ol style="list-style-type: none"> <li>1. Plugged or pinched vapor pipe or hoses, &amp; defective cap.</li> <li>2. Canister filter plugged &amp; defective cap.</li> </ol>  | <p>Check all lines from tank to canister and replace cap.</p> <p>Replace filter in canister &amp; cap.</p>  |
| Fuel Tank Rattles   | <ol style="list-style-type: none"> <li>1. Mounting straps loose.</li> <li>2. Baffle loose.</li> <li>3. Foreign material in tank.</li> </ol>   | <p>Tighten straps to specifications.</p> <p>Replace fuel tank.</p> <p>Remove tank and clean.</p>  |
| Fuel Starvation     | <ol style="list-style-type: none"> <li>1. Tank gage unit filter plugged.</li> <li>2. Fuel line pinched, plugged or mis-routed.</li> </ol>   | <p>Replace filter.</p> <p>Check open or re-route as required.</p>   |

Fig. 6C-10--Fuel Tank Diagnosis



## FUEL FILTER

### GENERAL DESCRIPTION

All gasoline engine fuel filters are located in the carburetor fuel inlet. These fuel filter elements are of pleated paper. Elements are placed in the inlet hole with the gasket surface outward. A spring holds the element outward, sealing it by compressing a gasket surface against the inlet fitting.

### ON-VEHICLE SERVICE

The carburetor inlet fuel filter should be replaced at intervals shown in Section 0B. A plugged filter and/or check valve will restrict fuel flow.

After assembling any filter element in the carburetor, always start the engine and check for leaks in the fuel line and fittings before installing the air cleaner.

#### Other Filters or Strainers

A woven plastic filter is located on the lower end of the fuel pickup pipe in the gas tank. This filter prevents dirt from entering the fuel line and also stops water unless the filter becomes completely submerged in water. This filter is self cleaning and normally required no maintenance. Fuel stoppage at this point indicates that the gas tank contains an

abnormal amount of sediment or water; the tank should therefore be removed and thoroughly cleaned.

### Fuel Filter Replacement

1. Disconnect fuel line connection at fuel inlet filter nut.
2. Remove fuel inlet filter nut from carburetor.
3. Remove filter and spring.
4. If removed, install check valve in fuel inlet filter.

The fuel inlet check valve must be installed in the filter to meet Motor Vehicle Safety Standards (M.V.S.S.) for roll-over. New service replacement filter must include the check valve.

5. Install fuel inlet filter spring, filter, and check valve assembly in carburetor. Check valve end of filter faces toward fuel line. Ribs on closed end of filter element prevent filter from being installed incorrectly unless forced.
6. Install new gasket on fuel inlet filter nut and install nut in carburetor. Tighten nut to 24 N m (18 ft. lbs.). Tightening beyond specified torque can damage gasket.
7. Install fuel line and tighten connection.
8. Start engine and check for leaks.

## FUEL PUMP

### GENERAL DESCRIPTION

The fuel pump (Figs. 6C-11 through 6C15) is a diaphragm type pump and is actuated by the rocker arm through a link and a push rod.

Some vehicles have a fuel pump with an outlet for a vapor return system. Any vapor which forms is returned to the fuel tank along with hot fuel through a separate line. This greatly reduces any possibility of vapor lock by keeping cool fuel from the tank constantly circulating through the fuel pump.

### DIAGNOSIS

Complete diagnosis of all possible causes of the trouble prior to replacement of the fuel pump will save time, expense and possible causes of the trouble prior to replacement of the fuel pump will save time, expense and possibly prevent a repeat complaint.

#### Low Pressure Complaint

The only way to check fuel pump pressure is by connecting an accurate pressure gage to the fuel line at carburetor level. Never replace a fuel pump without first making that simple check.

#### Not Enough Fuel Flow Complaint

When an engine has a "starving-out" condition, many mechanics jump to the conclusion that the fuel pump is not pumping enough fuel. Many times the "starving-out" condition is actually due to a weakness in the ignition system, since these two troubles are very hard to separate. Even when an engine is starving for fuel, the cause is more

likely to be a plugged fuel filter or a restricted fuel line than a malfunctioning fuel pump.

### ON-VEHICLE SERVICE

#### Inspection and Test

If the fuel system is suspected of delivering an improper amount of fuel to the carburetor, it should be inspected and tested in the vehicle, as follows:

#### Inspection of Fuel System

1. Make certain that there is fuel in the tank.
2. With the engine running, inspect for leaks at all fuel feed hose connections from fuel tank to carburetor. Tighten any loose connections. Inspect all hoses for flattening or kinks which would restrict the flow of fuel. Air leaks or restrictions on suction side of mechanical fuel pump will seriously affect pump output.
3. Inspect for leaks at fuel pump diaphragm flange.
4. Disconnect feed pipe near carburetor.
5. Disconnect distributor connectors so that engine can be cranked without firing. Place suitable container at end of pipe and crank engine a few revolutions. If no fuel, or only a little flows from pipe, the feed line is clogged or fuel pump is inoperative. Before condemning the fuel pump, disconnect feed line at both ends and blow through it with air hose to make certain that fuel pump is operating within specifications.

#### Fuel Pump Pressure Test

1. Disconnect fuel line at pump and connect a suitable pressure gage.
2. Start engine and check pressure with engine running

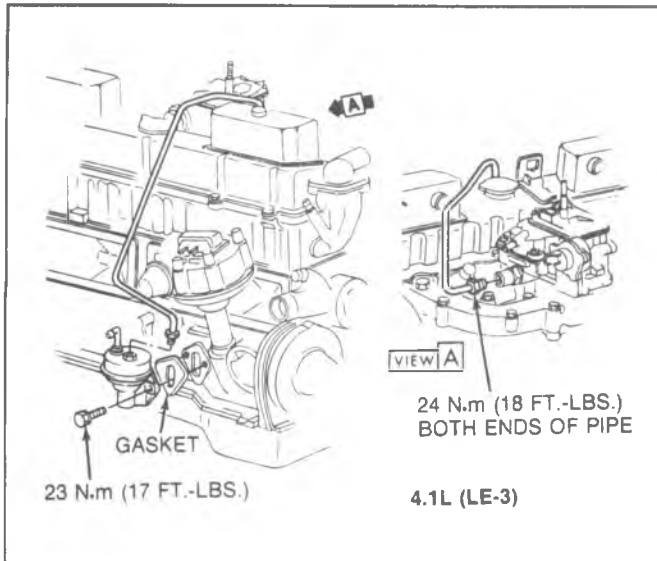

Fig. 6C-11--Fuel Pump--4.1 L

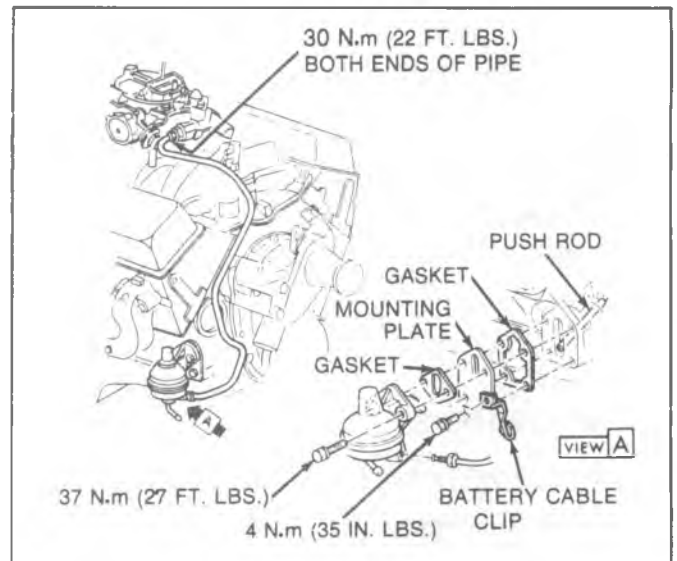

Fig. 6C-14--Fuel Pump--5.7 L

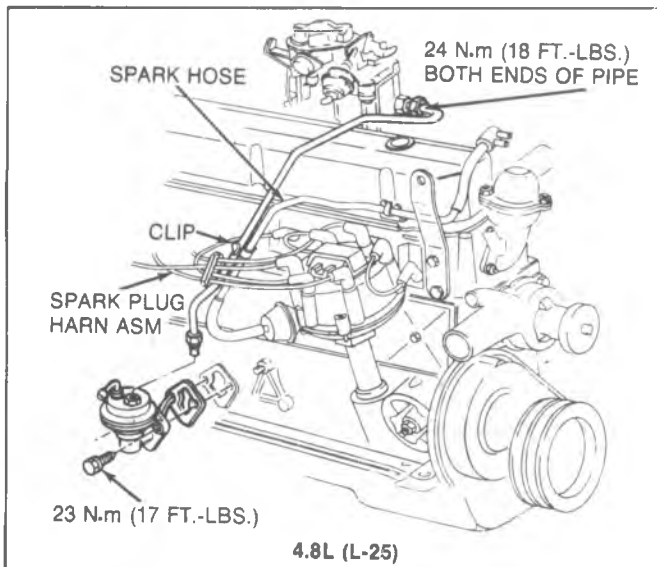

Fig. 6C-12--Fuel Pump--4.8 L

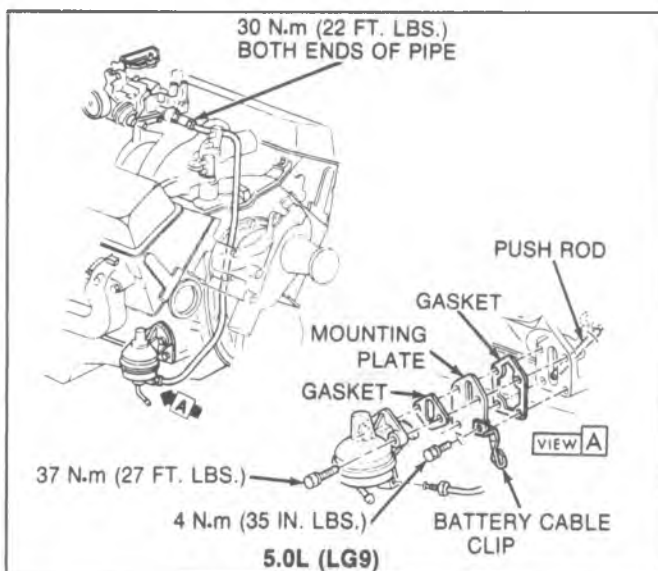

Fig. 6C-13--Fuel Pump--5.0 L

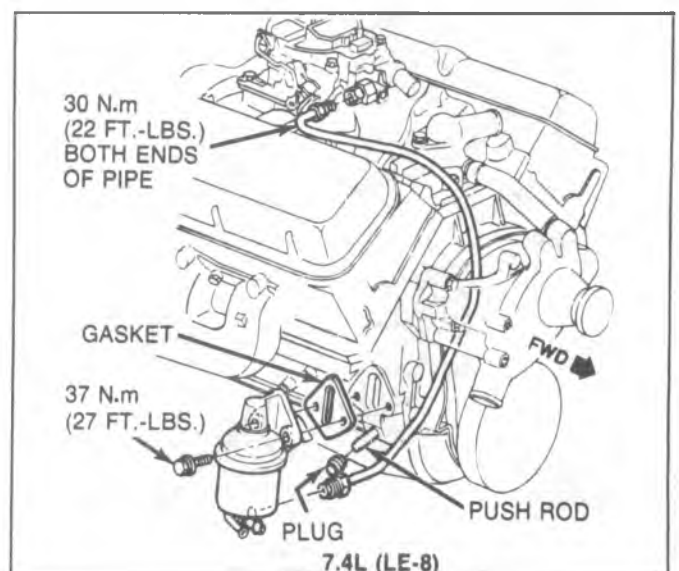

Fig. 6C-15--Fuel Pump--7.4 L

at slow idle speed. Fuel pump pressure should be as specified at the end of this section. On vehicles equipped with a vapor return system, squeeze off the return hose so that an accurate reading can be obtained.

3. If fuel pump pressure is below minimum, pump must be replaced.

#### Fuel Pump Flow Test

1. Disconnect fuel line from carburetor. Run fuel line into a suitable measuring container.
2. While observing the sweep second hand of a clock or watch, run the engine at idle until there is one pint of fuel in the container. One pint should be pumped in 30 seconds or less.
3. If flow is below minimum, check for restriction in the line.

#### Removal

1. Disconnect fuel inlet hose from pump. Disconnect vapor return hose, if so equipped.

2. Disconnect fuel outlet pipe.
3. Remove two bolts holding fuel pump.
4. Remove fuel pump, push rod, gasket and mounting plate (if used).

**Installation**

1. Install push rod, gasket, mounting plate (if used) and fuel pump.
2. Install two hex head bolts, turning them alternately and evenly.

3. Install fuel outlet pipe. If it is difficult to start fitting, time can be saved by disconnecting upper end of pipe from carburetor. Tighten fitting securely, meanwhile holding fuel pump nut with a wrench. Install and tighten fitting at carburetor, if removed.
4. Install fuel inlet hose and clamp. Install vapor return hose and clamp, if so equipped.
5. Start engine and check for leaks.

**FUEL TANK**

8. Reverse removal procedure to install fuel tank.

**ON-VEHICLE SERVICE**

**Outside Frame Rail Fuel Tank-**

**Cab and Crewcab (Figs. 6C-16 and 18)**

1. Drain tank.
2. Disconnect fuel lines, meter wire and ground lead.
3. Remove strap supports (lines, vent) and clip.
4. Loosen clamps from filler neck and vent line.
5. Remove strap bolts and lock washers from tank front and rear locations on inside frame rail.
6. Remove tank from frame simultaneously disengaging filler neck hose from filler neck (Fig. 6C-18 and 6C-19).
7. Remove meter assembly from fuel tank using Tool J-24187 (Fig. 6C-20).

**Center and Auxiliary Fuel Tank**

CK 10 and 20 (06, 16) (Figs. 6C-21, 22) G Van (Fig. 6C-23).

1. Drain tank.
2. Raise vehicle on hoist.
3. Unclamp upper filler neck and vent tube hose (Fig. 6C-18 and 19).
4. Unclamp gage unit hoses at frame end.
5. Support tank and remove support straps.
6. Lower tank and disconnect meter wire.
7. Remove tank.
8. Install in the reverse order, using new antisqueak material.
9. Lower vehicle and remove from hoist.

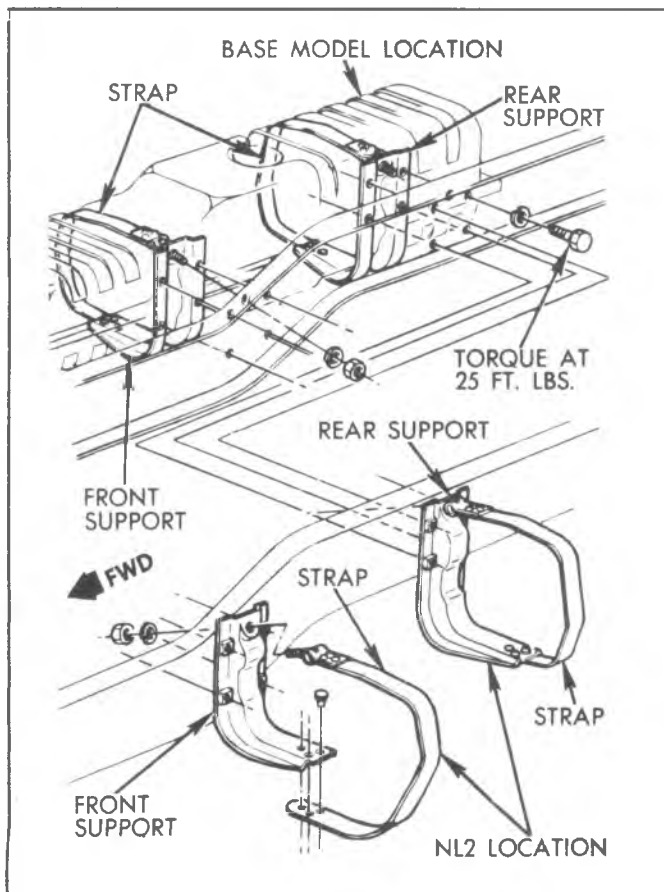

Fig. 6C-16--Fuel Tank Mounting-Cab and Crewcab

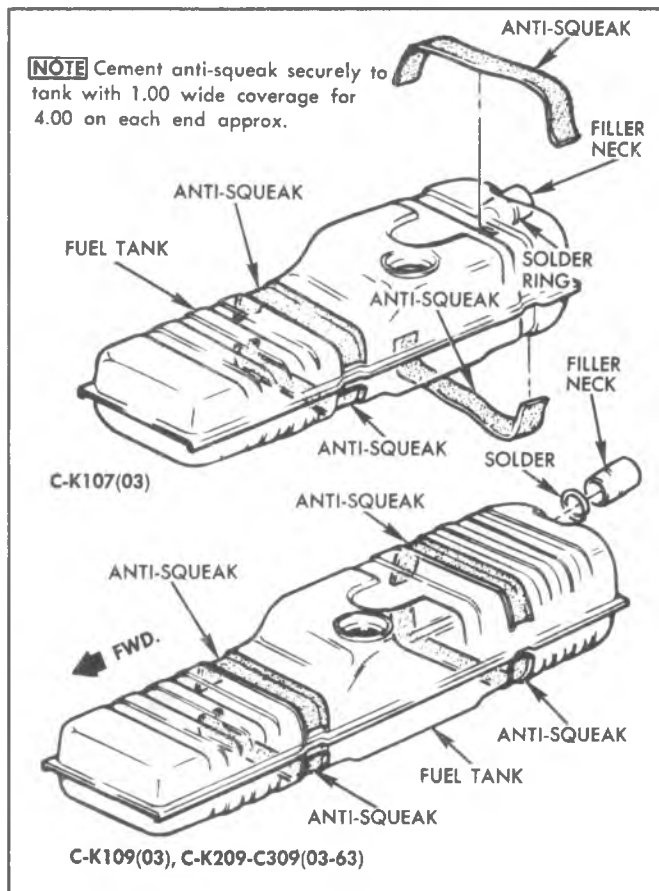

Fig. 6C-17--Fuel Tank-Cab and Crewcab

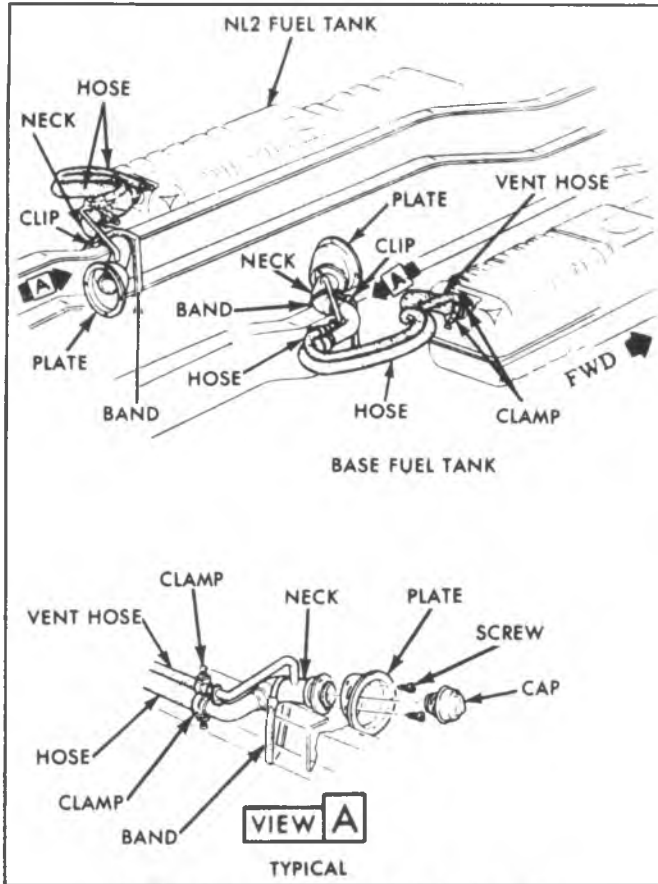

Fig. 6C-18--Fuel Tank Filler Neck (03 & 43)

**Frame Mounted Fuel Tank - P Model (Figs. 6C-25 and 26)**

1. Drain tank.
2. Remove filler neck.
3. Disconnect meter unit fuel line and wiring.
4. Remove bolts attaching tank supports to frame.
5. Remove tank complete with mounting bracket and support straps.
6. Remove tank from brackets and support straps, if necessary.

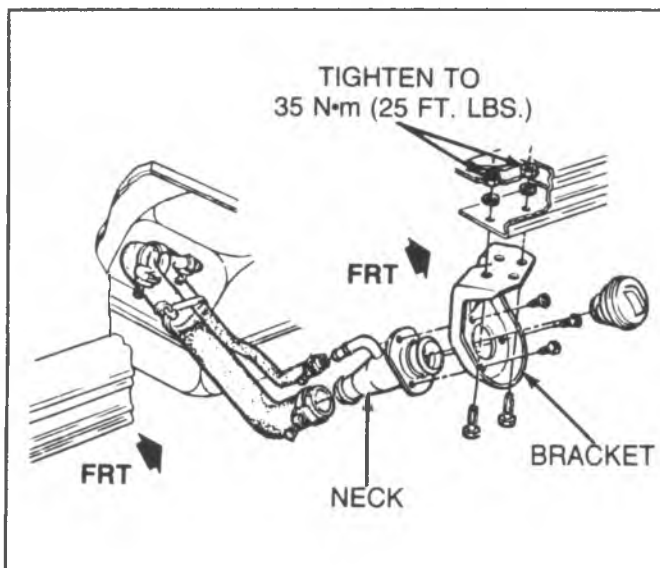

Fig. 6C-19--Filler Neck-Cab Stake Body



Fig. 6C-20--Removing Meter Assembly

7. Install in reverse order and replace antisqueak material.

**CLEANING FUEL SYSTEM**

**Cleaning**

If trouble is due to contaminated fuel or foreign material that has been put into the tank, it can usually be cleaned. If tank is rusted internally, it should be replaced.

1. Disconnect battery negative cable and distributor feed wire.

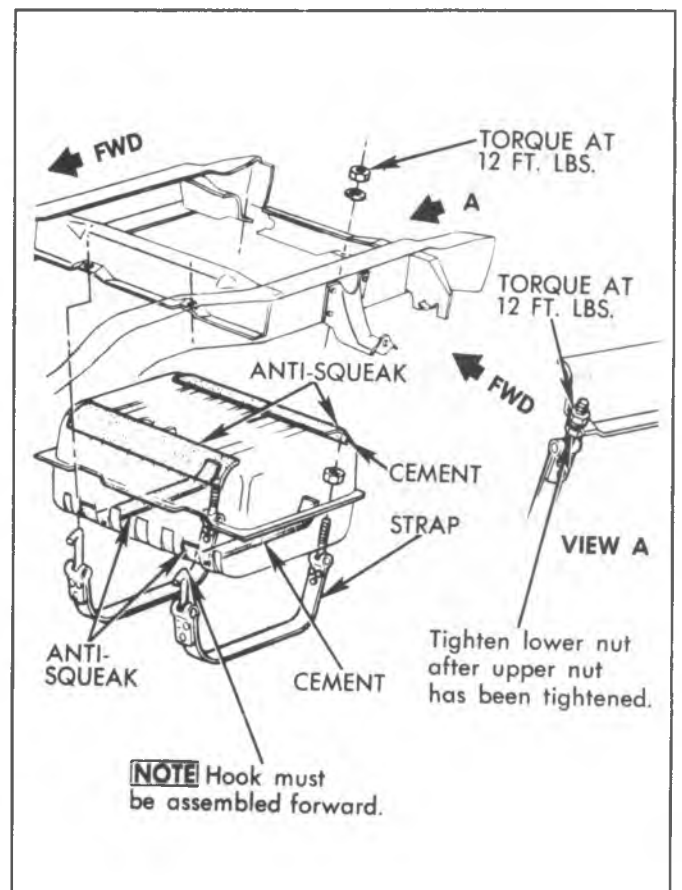

Fig. 6C-21--Fuel Tank, CK 10-20 (06, 16)

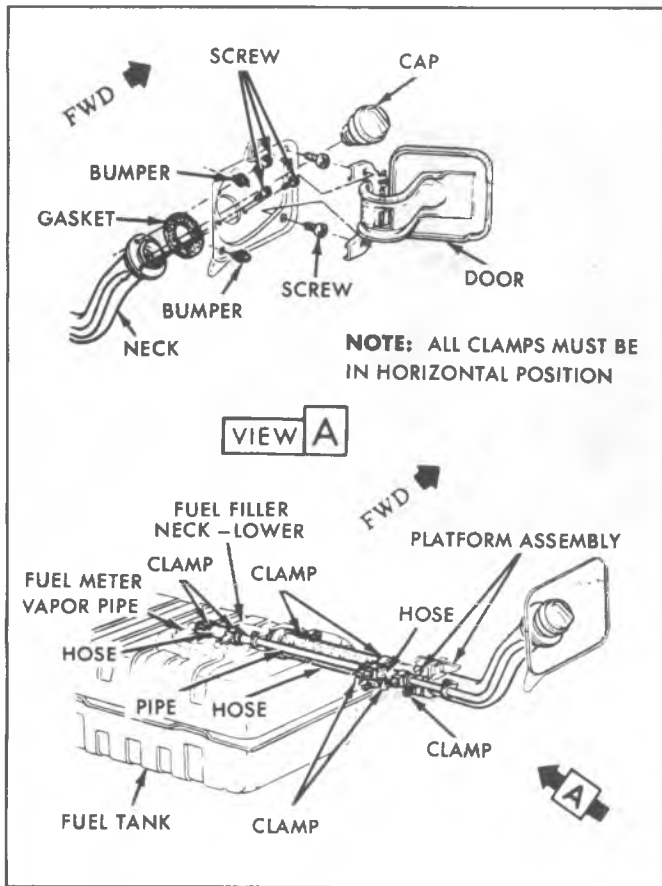

Fig. 6C-22--Fuel Tank, CK 10-20 (06, 16)

2. Drain fuel tank.
3. Remove fuel tank.
4. Remove fuel inlet filter at carburetor and inspect for contamination. If filter is plugged replace (leave fuel line disconnected).
5. Locate tank away from heat, flame, or other source of ignition. Remove fuel gage tank unit and inspect condition of filter. If filter is contaminated a new filter should be installed upon reassembly.
6. Complete draining of tank by rocking it and allowing fuel to run out of tank unit hole.
7. Purge fuel tank with steam or running hot water for at least five minutes. Pour water out of tank unit hole (rock tank to assure complete removal of water).

This procedure will not remove fuel vapor. Do not attempt any repair on tank or filler neck where heat or flame is required.

8. Disconnect inlet fuel line at pump and use air pressure to clean fuel line and fuel return line (if

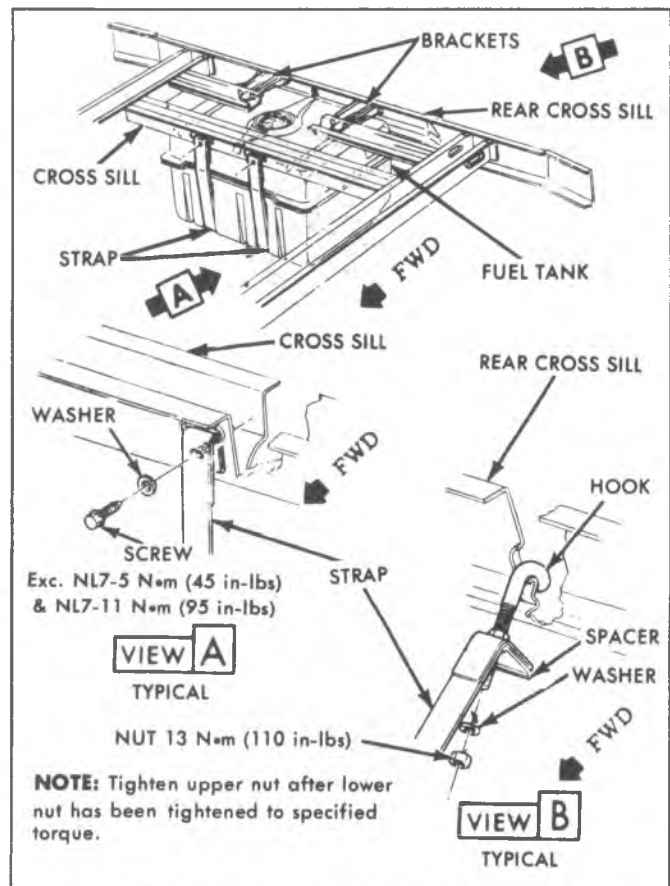

Fig. 6C-23--Fuel Tank Installation G Van

- equipped). Apply air pressure in the direction fuel normally flows through line.
9. Use low air pressure to clean pipes on tank unit.
10. Clean filter on fuel tank unit, if required. Install fuel tank gage unit, (with new gasket) into tank and install tank. Connect tank unit wires and all fuel lines, except pump to carburetor line (see "Removal of Tank" for proper procedure).
11. Connect a hose to fuel line at carburetor; insert other end of hose into a one gallon fuel can.
12. Connect battery cable. Make sure distributor feed wire is disconnected.
13. Put six gallons of clean fuel in tank and operate starter to pump two quarts of fuel into fuel can. This will purge fuel pump.
14. Remove hose and connect fuel line to carburetor.
15. Connect distributor feed wire.
16. Check all connections for leaks.

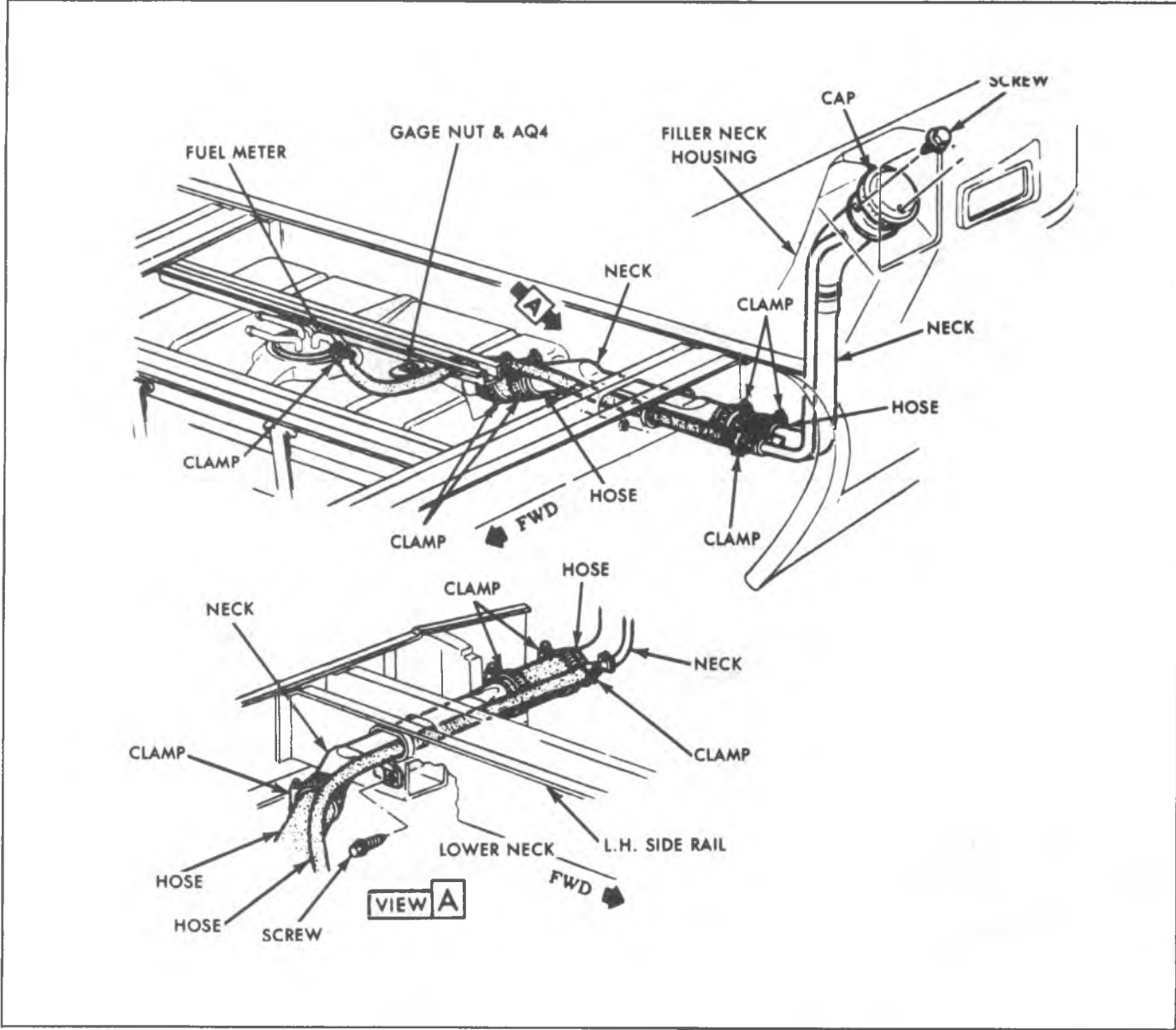

Fig. 6C-24--Fuel Tank and Filler Neck G Van

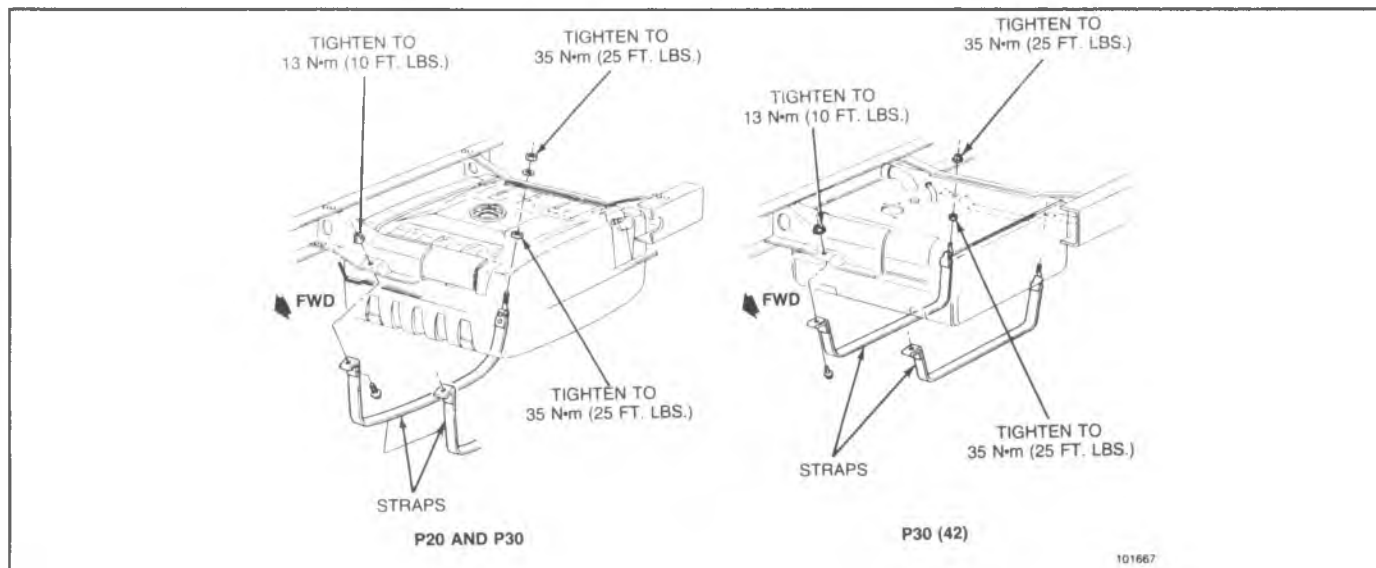

Fig. 6C-26--Fuel Tank Mounting - P Model

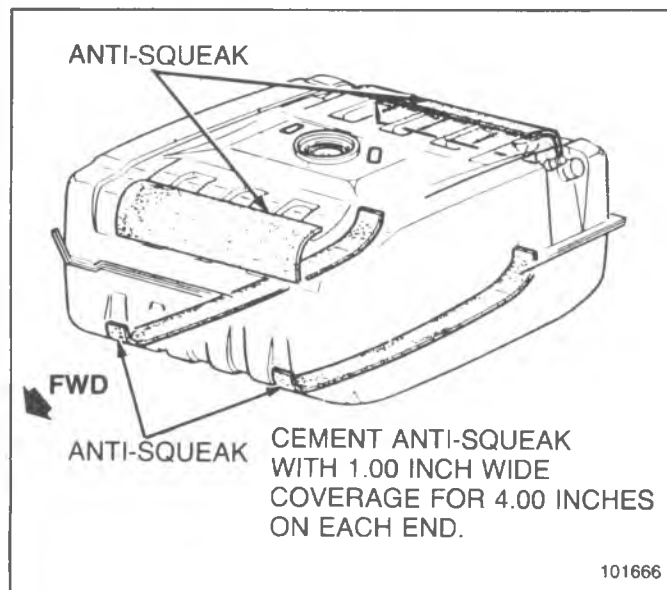

Fig. 6C-25--Fuel Tank - P Model

### AUXILIARY FUEL TANK CONTROL

The auxiliary fuel tank switch (Fig. 6C-26a) is located on the instrument panel, just left of the ashtray. The switch controls fuel tank switching and fuel gage indication in a single operation.

## FUEL FEED AND VAPOR PIPES

### GENERAL DESCRIPTION

Fuel feed pipes are secured to the underbody with clamp and screw assemblies. Flexible hoses are located at fuel tank fuel, vapor and return lines and fuel pump. The

To operate:

Depress the rocker switch at the TOP for the Right Hand (R.H.) tank; at the BOTTOM for the Left Hand (L.H.) tank. When pressing the switch, a detent will be felt. Continue pressing beyond the detent and hold momentarily (1 second or more) to fully activate the tank switching unit. Release the switch and it will return to the detent position.

A simple check can be made to determine if the Fuel Tank Selector Valve is operating by listening for audible operation of the motor inside the selector valve, when the switch is pressed.

### Fuel Tank Selector Valve

#### Replacement (Fig. 6C-27)

1. Disconnect battery.
2. Remove hose shield and brace.
3. Remove fuel and vapor hoses noting their position for later installation.
4. Remove two screws holding valve to frame and remove valve.
5. Install valve and tighten screws.
6. Install fuel and vapor hoses in same positions noted at removal.
7. Install brace and hose shield.
8. Connect battery.

pipes should be inspected occasionally for leaks, kinks or dents. If evidence of dirt or foreign material is found in carburetor, fuel pump or pipes, pipe should be disconnected and blown out. Dirt or foreign material may be caused by a damaged or omitted fuel strainer in fuel tank.



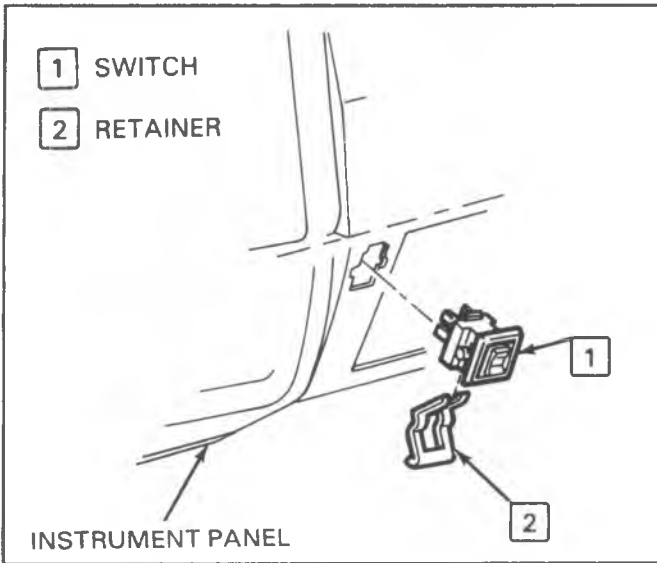

Fig. 6C-26a -- Auxiliary Tank Switch

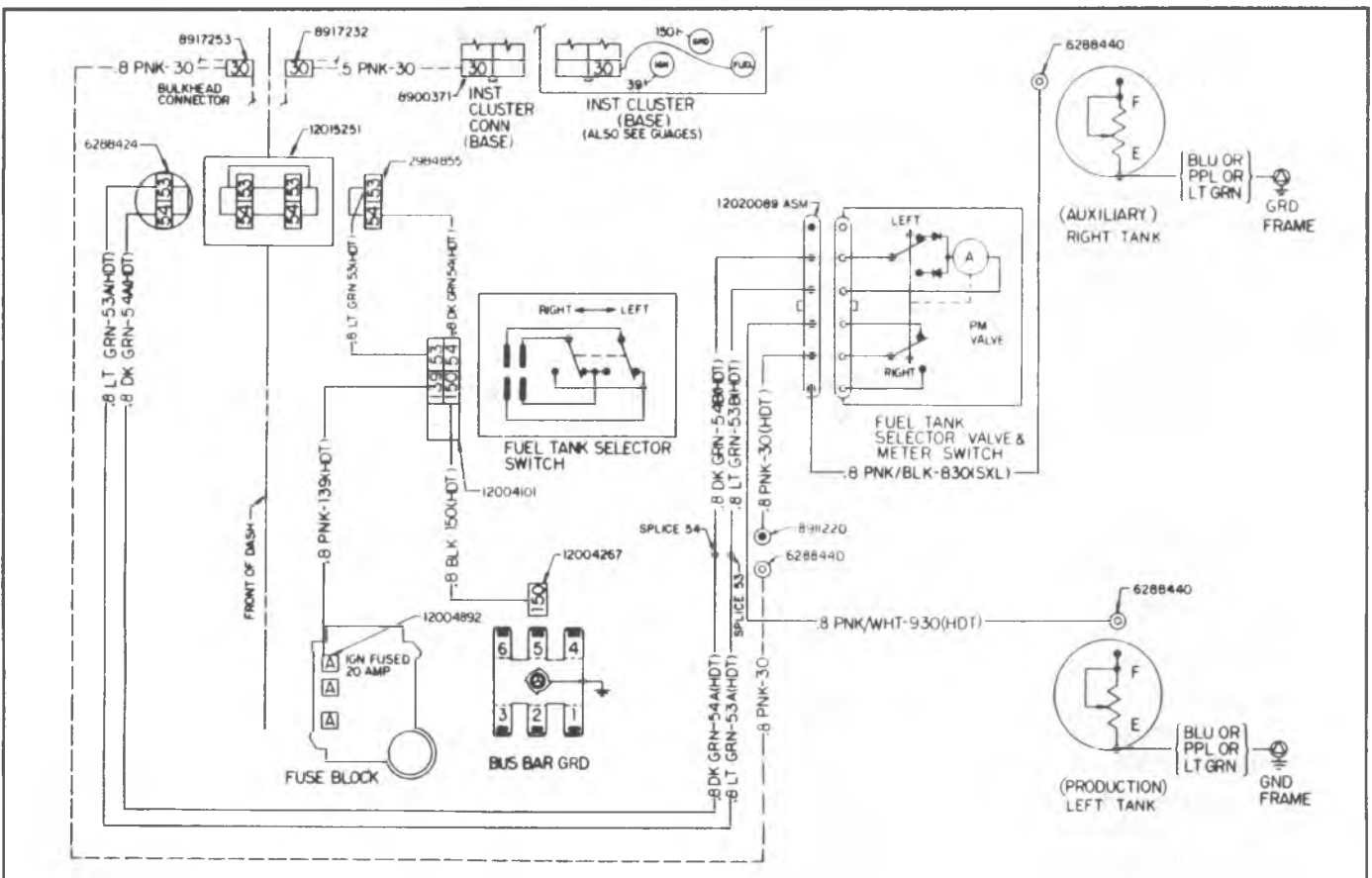

Fig. 6C-26b -- Auxiliary Tank Wiring



## ON-VEHICLE SERVICE

### Fuel Line Repair

#### Replacement

1. If replacement of a fuel feed, fuel return or emission pipe is required use welded steel tubing meeting GM Specification 124-M or its equivalent.
2. Do not use copper or aluminum tubing to replace steel tubing. Those materials do not have satisfactory durability to withstand normal vehicle vibrations.
3. When rubber hose is used to replace pipe, use only reinforced fuel resistant hose which meets GM Specification 6165-M. Hose inside diameter must match pipe outside diameter.
4. Do not use rubber hose within 4" (100 mm) of any part of the exhaust system or within 10" (254 mm) of the catalytic converter.

5. In repairable areas, cut a piece of fuel hose 4" (100 mm) longer than portion of the line removed.

If more than a 6 inch (152 mm) length of pipe is removed, use a combination of steel pipe and hose so that hose lengths will not be more than 10 inches (254 mm).

Follow the same routing as the original pipe.

6. Cut ends of pipe remaining on car square with a tube cutter. Using the first step of a double flaring tool, form a bead on the end of both pipe sections. If pipe is too corroded to withstand bead operation without damage, the pipe should be replaced. If a new section of pipe is used, form a bead on both ends of it also.
7. Use screw type hose clamp, Part Number 2494772, or equivalent. Slide clamps onto pipe and push hose 2" (51 mm) onto each portion of fuel pipe. Tighten clamps on each side of repair.
8. Pipes must be properly secured to the frame to prevent chafing.

## EVAPORATIVE CONTROL SYSTEM (ECS)

### GENERAL DESCRIPTION

All light duty emissions and some heavy duty emission vehicles are equipped with a system designed to prevent escape of fuel vapor to the atmosphere. Vapor generated by evaporation of fuel in the tank, previously exhausted to atmosphere, is transferred by an emission line to the engine compartment. During periods of operation, vapors are fed directly to the engine for consumption. During periods of inoperation, an activated charcoal canister located in the emission line stores any vapor generated for consumption during the next period of operation.

The amount of vapor drawn into the engine at any time is too small to have any effect on fuel economy or engine operation.

With this closed system it is extremely important that only vapors be transferred to the engine. To avoid the possibility of liquid fuel being drawn into the system, these following features are included as part of the total system:

1. A fuel tank overfill protector is provided on all series to assure adequate room for expansion of liquid fuel volume with temperature changes.
2. A one point fuel tank venting system is provided on all series to assure that the tank will be vented under any conceivable vehicle attitude.
3. To protect the tank from mechanical damage in the event of excessive internal or external pressures resulting from the operation of this closed system, a pressure-vacuum relief valve, located in the gas cap, will control the tank internal pressure.

### ON-VEHICLE SERVICE

Maintenance requirement is that the oiled fiberglass filter assembled in the bottom of the canister, be replaced at intervals shown in Section 0B. Under extremely dusty conditions, more frequent attention may be required.

Check operation of bowl vent and purge valve.

### Canister and Filter

#### Removal

1. Note installed position of hoses on canister.
2. Disconnect hoses from top of canister.
3. Loosen clamps and remove canister.
4. If replacing filter, pull out filter from bottom of canister with your fingers.

#### Inspection

1. Check hose connection openings. Assure that they are open.
2. Check operation of purge valve by applying vacuum to the valve. A good valve will hold vacuum.

#### Installation

1. Install new filter.
2. Install canister and tighten clamp.
3. Connect hoses in same order.

### Canister Purge Valve

#### Disassembly

1. Disconnect lines at valve.
2. Snap off valve cap (slowly remove cap as diaphragm is under spring tension). Remove diaphragm, spring retainer and spring.
3. Replace parts as necessary. Check orifice openings.

#### Assembly

1. Install spring, spring retainer, diaphragm and cap.
2. Connect lines to valve.

#### Checking Purge Valve

1. Remove purge valve control vacuum line. Check for a vacuum signal with engine operating above idle (1500 RPM). If no vacuum signal, perform EGR System Function Check.

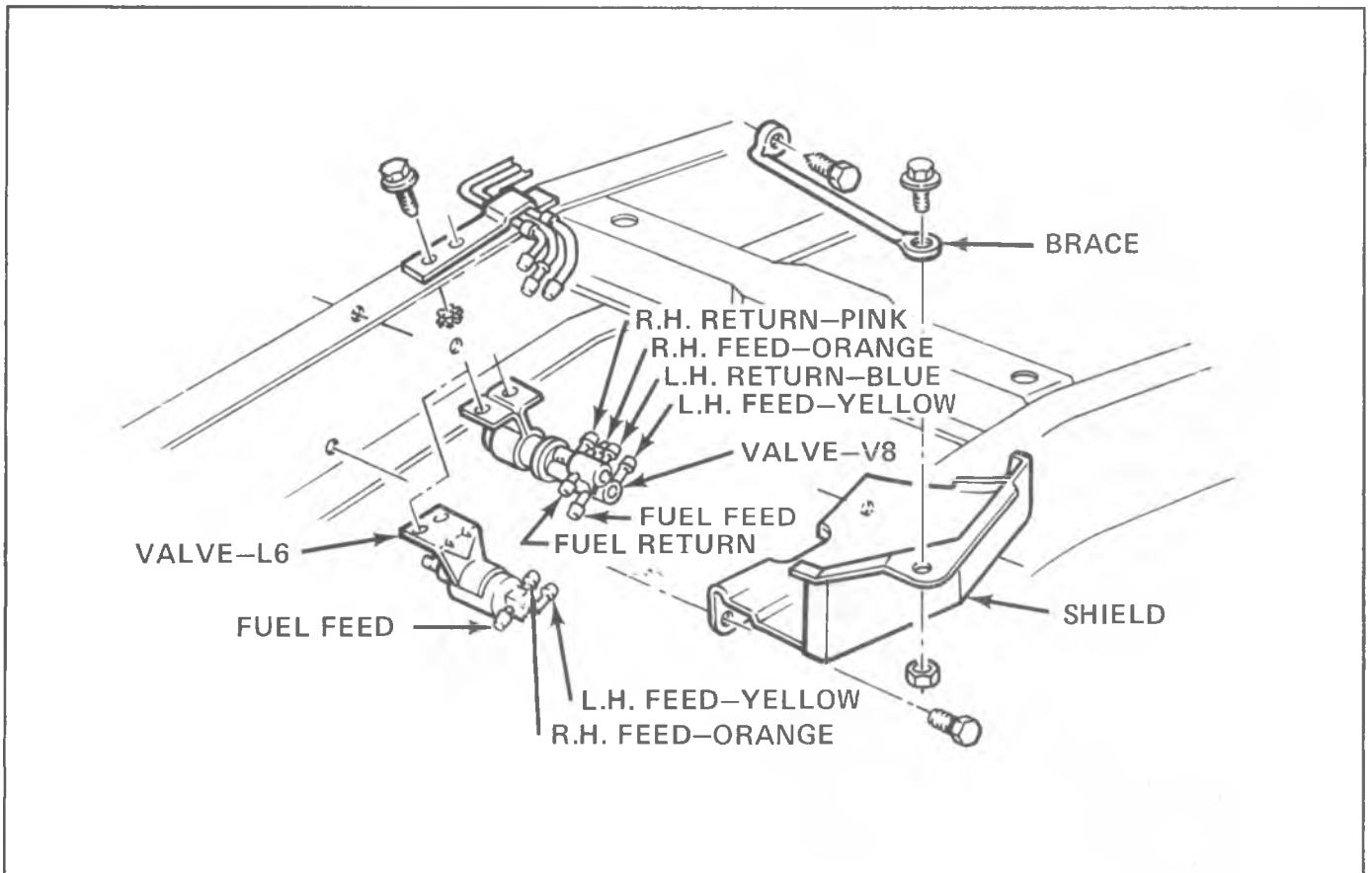

Fig. 6C-27--Selector Valve

2. Apply an external vacuum source to the purge valve control diaphragm. A good valve will hold vacuum.
3. If the valve will not hold vacuum, replace canister.
4. If valve holds vacuum, remove purge line and check for vacuum. If no vacuum, check PCV hoses and system. Repair or replace as necessary.

#### Checking Bowl Vent Valve

1. Remove the bowl vent vapor hose from the carburetor.
2. Check the open condition of the valve by connecting to a manual vacuum pump. It should not be possible to obtain .5 inch Hg if the valve is open.
3. If a high resistance or plugged system is found, check for a plugged or restricted hose. Hose may be cleared with compressed air. If the hose is clear, remove the canister filler. If the restriction persists, replace the canister.
4. A simple check of the valve closed condition can be obtained with the same procedure as in Step 2, but with the engine operating at operating temperature. Manifold vacuum will be applied to the valve through the control line. The bowl vent line should exhibit a plugged condition.
5. If the valve is not closed, remove the control vacuum line and check for vacuum. If no vacuum is present, check hose for restriction or vacuum leak. Repair or replace as required. If vacuum is present, replace canister.

#### Pressure Checking Evaporative Control System

1. Stabilize vehicle by operating until warmed up.
2. Remove tank line at canister and observe for liquid in the line. Hook-up pressure device.
3. Apply 15" H<sub>2</sub>O pressure to the fuel vapor line.
  - A. Observe for excessive loss of pressure.
  - B. If negligible pressure loss occurs observe for fuel vapor smell or fuel loss at points listed in Diagnostics under Possible Cause.
  - C. Remove fuel filler cap(s) and observe for pressure in tank(s).
4. Remove fuel cap (LH on dual tank units) and blow on vent line to check for obstructions. (Install LH cap on dual tank units and remove RH cap. Repeat above.)

## ACCELERATOR CONTROLS

### GENERAL

The accelerator control system is cable type. There are no linkage adjustments. A reference between the bottom of

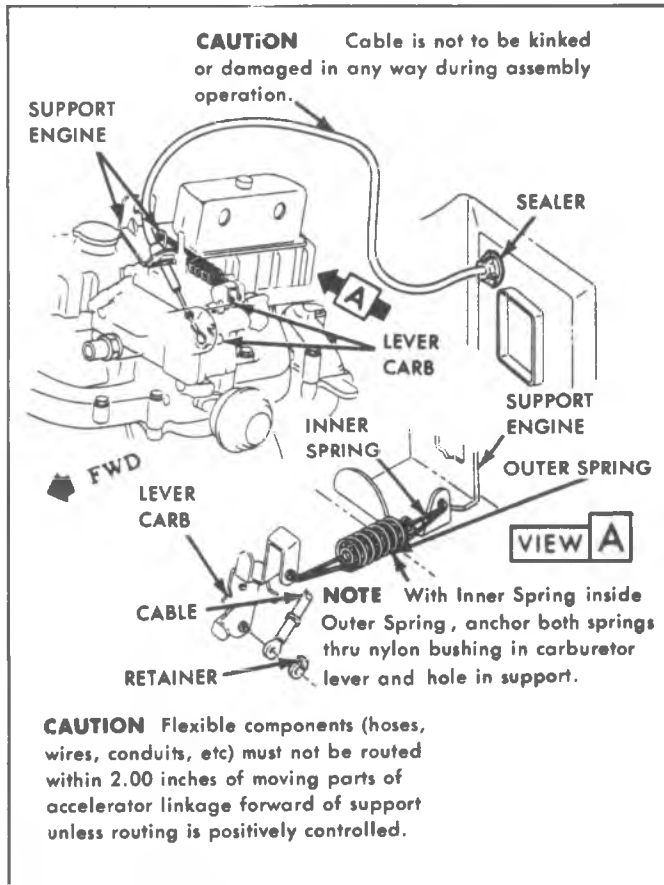

Fig. 6C-28--Accelerator Controls L6-Light Duty Emissions

accelerator pedal and floor pan should be used only as a check for bent bracket assembly. Check torque references.

Check for correct opening and closing positions by operating accelerator pedal and if any binding is present, check routing of cable.

### ACCELERATOR CONTROL CABLE

Refer to figures 6C-28 through 6C-31 for removal and installation of accelerator control cable.

### ACCELERATOR PEDAL

Refer to figures 6C-32 through 35 for removal and installation of accelerator pedal.

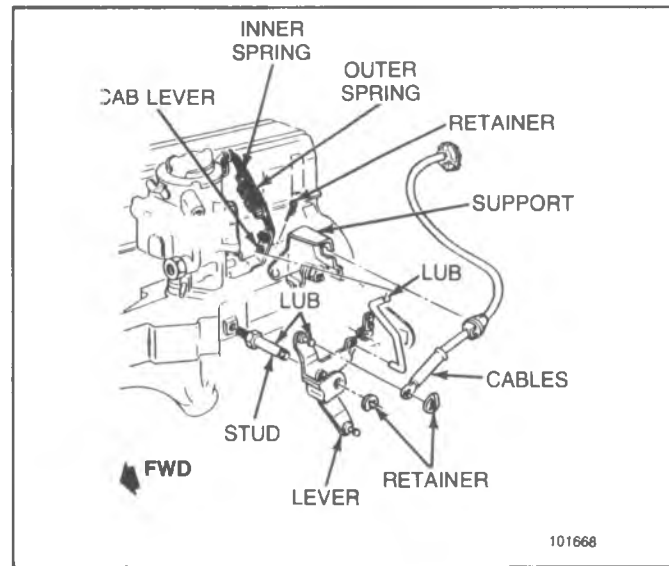

Fig. 6C-29--Accelerator Controls L6-Heavy Duty Emissions.

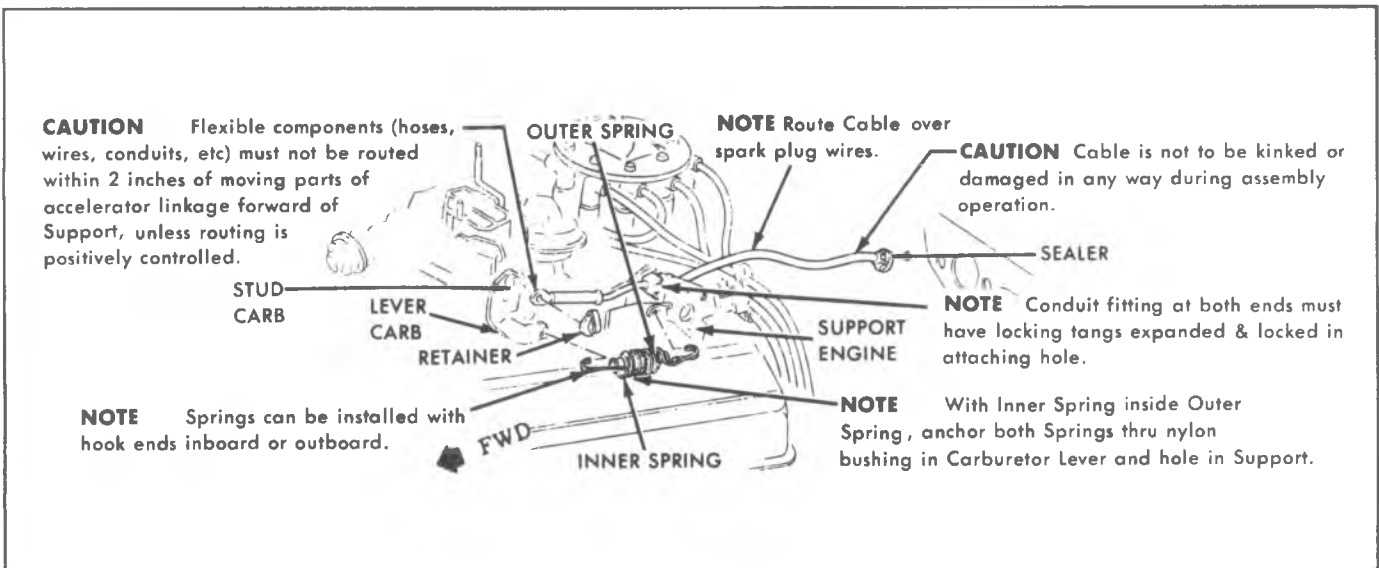

Fig. 6C-30--Accelerator Controls V8-2Bbl.

**CAUTION** Flexible components (hoses, wires, conduits, etc.), must not be routed within 2 inches of moving parts of accelerator linkage forward of Support unless routing is positively controlled.

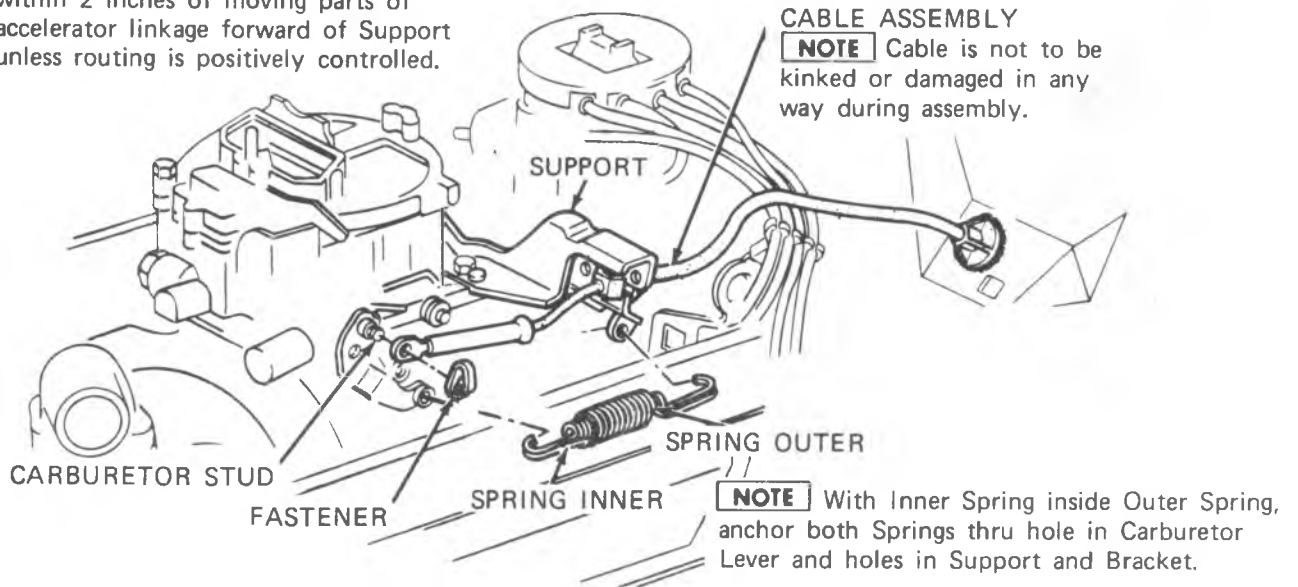
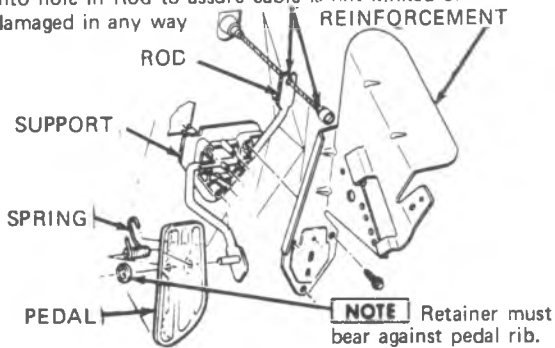

Fig. 6C-31--Accelerator Controls V8-4Bbl.

**NOTE** Slip accelerator control cable thru slot in Rod. Install retainer, being sure it is seated.

**CAUTION** Care must be used in pressing the retainer into hole in Rod to assure cable is not kinked or damaged in any way



**NOTE** Having secured all components of the accelerator linkage as specified, linkage must operate freely without bind between full closed throttle and full wide open throttle.

Fig. 6C-32--Accelerator Pedal-CK

**CAUTION:** Care must be used in pressing Retainer into hole in Rod to assure Cable is not kinked or damaged in any way.

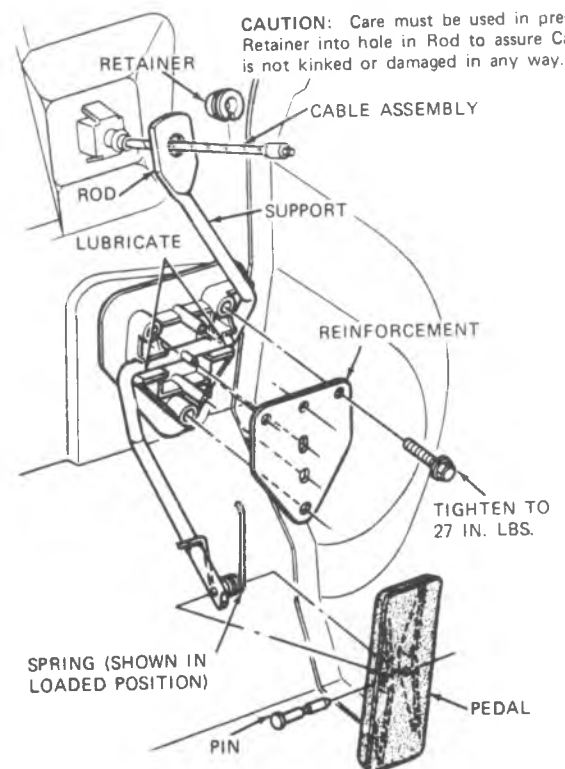

Fig. 6C-33--Accelerator Pedal-G

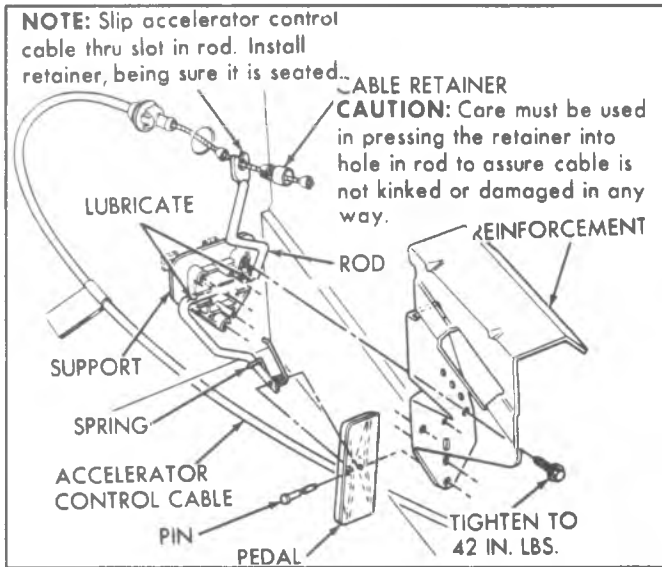

Fig. 6C-34--Accelerator Pedal-P42

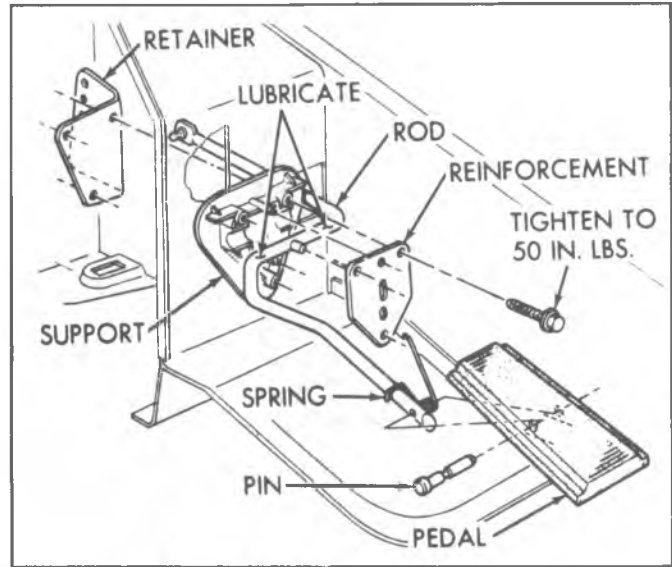

Fig. 6C-35--Accelerator Pedal-P32

## SPECIFICATIONS

### FUEL PUMP PRESSURE

| ENGINE                                 | P.S.I. |
|--|--------|
| L6 (ALL)                               | 4½-6   |
| V8 (ALL)<br>WITHOUT VAPOR RETURN LINE  | 7½-9   |
| V8 (EXC LF8)<br>WITH VAPOR RETURN LINE | 5½-7   |
| V8 (LF8)<br>WITH VAPOR RETURN LINE     | 7½-9   |

### TORQUE SPECIFICATIONS IIME CARBURETOR

| SCREW                 | TORQUE<br>(IN. LBS.) | SCREW          | TORQUE<br>(IN. LBS.) |
|-----------------------|----------------------|----------------|----------------------|
| AIR HORN TO BOWL      | 45                   | FUEL INLET NUT | 400                  |
| AIR CLEANER BRIDGE    | 70                   | FAST IDLE CAM  | 50                   |
| THROTTLE BODY TO BOWL | 180                  | CHOKE LEVER    | 25                   |
| NEEDLE SEAT           | 45                   | PUMP LEVER     | 30*                  |
| METERING JET          | 40                   |                |                      |

\*Loctite AVV or equivalent

### M2M- M4M CARBURETOR

| SCREW   | TORQUE<br>(IN. LBS.)                                |
|---|---|
| THROTTLE BODY<br>THROTTLE BODY TO BOWL  | 46  |
| CHOKE HOUSING<br>CHOKE LEVER<br>CHOKE HOUSING ATTACHING<br>CHOKE HOUSING COVER  | 14<br>46<br>26                                      |
| AIR HORN<br>AIR HORN TO BOWL 10-32<br>AIR HORN TO BOWL 8-32<br>AIR HORN TO THROTTLE BODY<br>CHOKE LEVER<br>VACUUM BREAK UNIT<br>FUEL INLET NUT<br>NEEDLE SEAT<br>METERING JET<br>SOLENOID BRACKET | 46<br>26<br>46<br>14<br>26<br>400<br>45<br>40<br>71 |

Fig. 6C-36--Specifications

**ANGLE DEGREE TO DECIMAL CONVERSION  
MODEL M2MC, M2ME AND M4MC CARBURETOR**

THE RELATION BETWEEN DECIMAL AND ANGLE READINGS IS NOT EXACT DUE TO MANUFACTURING TOLERANCES OF THE COMPONENT PARTS. THIS CHART IS SUPPLIED FOR USE BY THE MECHANIC WHO HAS ACCESS TO PLUG GAUGES ONLY. THE RECOMMENDED TOOL IS AN ANGLE GAUGE FOR ACCURACY AND BEST OVERALL PERFORMANCE AND EMISSIONS.

| ANGLE DEGREES | DECIMAL EQUIV.<br>TOP OF VALVE | ANGLE DEGREES | DECIMAL EQUIV.<br>TOP OF VALVE |
|---------------|--------------------------------|---------------|--------------------------------|
| 5             | .023                           | 33            | .203                           |
| 6             | .028                           | 34            | .211                           |
| 7             | .033                           | 35            | .220                           |
| 8             | .038                           | 36            | .227                           |
| 9             | .043                           | 37            | .234                           |
| 10            | .049                           | 38            | .243                           |
| 11            | .054                           | 39            | .251                           |
| 12            | .060                           | 40            | .260                           |
| 13            | .066                           | 41            | .269                           |
| 14            | .071                           | 42            | .277                           |
| 15            | .077                           | 43            | .287                           |
| 16            | .083                           | 44            | .295                           |
| 17            | .090                           | 45            | .304                           |
| 18            | .096                           | 46            | .314                           |
| 19            | .103                           | 47            | .322                           |
| 20            | .110                           | 48            | .332                           |
| 21            | .117                           | 49            | .341                           |
| 22            | .123                           | 50            | .350                           |
| 23            | .129                           | 51            | .360                           |
| 24            | .136                           | 52            | .370                           |
| 25            | .142                           | 53            | .379                           |
| 26            | .149                           | 54            | .388                           |
| 27            | .157                           | 55            | .400                           |
| 28            | .164                           | 56            | .408                           |
| 29            | .171                           | 57            | .418                           |
| 30            | .179                           | 58            | .428                           |
| 31            | .187                           | 59            | .439                           |
| 32            | .195                           | 60            | .449                           |

Fig. 6C-37--Angle to Decimal Conversion

## SPECIAL TOOLS

|                                  |            |
|----------------------------------|------------|
| Idle Mixture Socket.....         | J-29030-B  |
| Adjustable Float Gage.....       | J-9789-90  |
| Bending Tool.....                | J-9789-111 |
| Needle Valve Seat Remover.....   | J-22769    |
| Carburetor Stand.....            | J-9789-118 |
| Float Level Gage.....            | J-9789-130 |
| Float Level Gage.....            | J-9789-135 |
| Carburetor Choke Angle Gage..... | J-26701-4  |

# SECTION 6C1

## E4ME CARBURETOR

### CONTENTS

|   |        |   |        |
|---|--------|---|--------|
| <b>GENERAL DESCRIPTION</b> .....                | 6C1-1  | Float Bowl Parts.....                         | 6C1-20 |
| <b>ON VEHICLE SERVICE</b> .....                 | 6C1-2  | Throttle Body .....                           | 6C1-20 |
| Float Level Check .....                         | 6C1-2  | Cleaning and Inspection.....                  | 6C1-21 |
| Choke, Check Procedure.....                     | 6C1-2  | Fuel Lines and Fuel Filter Check .....        | 6C1-22 |
| Checking Hot Air Choke.....                     | 6C1-2  | <b>CARBURETOR REASSEMBLY</b> .....            | 6C1-22 |
| Checking Electric Choke.....                    | 6C1-2  | Throttle Body .....                           | 6C1-22 |
| On Vehicle Speed Adjustment .....               | 6C1-2  | Float Bowl .....                              | 6C1-22 |
| Idle Speed Control ISC Adjustment.....          | 6C1-2  | Choke Housing to Float Bowl.....              | 6C1-22 |
| Idle Load Compensator ILC Adjustment.....       | 6C1-7  | Completion of Float Bowl.....                 | 6C1-23 |
| A/C Idle Speed Solenoid ISS Adjustment .....    | 6C1-9  | Air Horn .....                                | 6C1-24 |
| --Throttle Position Sensor TPS Adjustment ..... | 6C1-9  | Air Horn to Bowl.....                         | 6C1-24 |
| Checking Mixture Control Solenoid Plunger       |        | <b>ADJUSTMENT PROCEDURES</b> .....            | 6C1-27 |
| Travel .....                                    | 6C1-10 | Float .....                                   | 6C1-27 |
| Mixture Control Solenoid Plunger Adjustment..   | 6C1-10 | Lean Mixture (Solenoid) Screw-Bench           |        |
|   |        | Adjustment.....                               | 6C1-28 |
| Idle Mixture and Speed Adjustment .....         | 6C1-12 | Rich Mixture Stop Screw-Bench Adjustment..... | 6C1-28 |
| Idle Mixture Adjustment.....                    | 6C1-12 | Idle Mixture-Bench Adjustment .....           | 6C1-29 |
| Idle Air Bleed Valve Adjustment .....           | 6C1-14 | Air Valve Spring Adjustment .....             | 6C1-29 |
| Idle Mixture Needle Plug Removal.....           | 6C1-14 | Choke Coil Lever Adjustment.....              | 6C1-30 |
| Setting Idle Mixture Needles .....              | 6C1-14 | Choke Valve Angle Gage.....                   | 6C1-30 |
| Setting Idle Air Bleed Valve.....               | 6C1-14 | Choke Rod-Fast Idle Cam Adjustment.....       | 6C1-31 |
| Adjusting Idle Mixture Needles.....             | 6C1-14 | Vacuum Break Adjustment Information.....      | 6C1-31 |
| <b>UNIT REPAIR</b> .....                        | 6C1-14 | Front Vacuum Break Adjustment.....            | 6C1-32 |
| Carburetor Replacement .....                    | 6C1-14 | Rear Vacuum Break Adjustment.....             | 6C1-32 |
| Idle Control Devices.....                       | 6C1-15 | Air Valve Rod Adjustment-Front .....          | 6C1-33 |
| Air Horn .....                                  | 6C1-15 | Air Valve Rod Adjustment-Rear.....            | 6C1-33 |
| Float Bowl .....                                | 6C1-18 | Unloader Adjustment .....                     | 6C1-34 |
| Choke .....                                     | 6C1-19 | Secondary Lockout Adjustment.....             | 6C1-34 |
| Choke Cover .....                               | 6C1-20 | Carburetor Specifications .....               | 6C1-35 |

## GENERAL DESCRIPTION

The Models E4ME and E4MC Quadrajét Carburetors are of the four barrel, two stage design, used with the Computer Command Control System of fuel control, which is further described in Section 6E1 of this manual. The carburetor comprises three major assemblies: the air horn, the float bowl and the throttle body. It has six basic operating systems (Float, Idle, Main Metering, Power, Pump and Choke).

### *See Figures 6C1-2 through 6C1-8A*

A single float chamber supplies fuel to the four carburetor bores. A closed-cell rubber float, brass needle seat, and a rubber tipped float valve with pull clip, are used to control fuel level in the float chamber.

An electrically operated mixture control solenoid, mounted in the float bowl, is used to control the air and fuel mixture in the primary bores of the carburetor. The plunger in the solenoid is controlled (or "pulsed") by electrical signals received from the Electronic Control Module (ECM).

The air valves and metering rods control the air/fuel metering in the secondary bores. A pair of tapered metering rods are attached to a hanger, which operates by cam action resulting from the air valve angle, and provides the additional fuel flow necessary during increased engine air flow at wide open throttle. Model E4ME employs an electrically heated thermostatic coil to provide the choke

valve closing force for cold start-up and for correct opening timing during warmup, while Model E4MC uses a hot air heated thermostatic coil for these purposes. Vacuum break units control initial choke valve opening at start and during warmup. An unloader tang on the fast idle lever forces the choke valve open, to purge a flooded engine, when the accelerator is pressed to the floor. A fast idle cam, following the choke valve movement, acts as a graduated throttle stop, providing increased idle speed during warmup.

An Idle Speed Control (ISC) assembly, monitored by the ECM, controls engine idle speed. The curb (or base) idle speed is programmed into the ECM and IS NOT ADJUSTABLE. When the throttle lever is resting against the ISC plunger, the ISC acts as a "dashpot" on throttle closing. An Idle Speed Solenoid or Idle Load Compensator is used on some models to position the primary throttle valve, providing engine idle speed requirements.

On E4MC models, an Idle Load Compensator (ILC) mounted on the float bowl is used to control curb idle speeds. The ILC uses manifold vacuum to sense changes in engine load (for example, A/C compressor clutch engaged) and compensates by adjusting throttle angle for curb idle speed. The ILC uses a spring-loaded vacuum-sensitive diaphragm whose plunger either extends (vacuum decrease) or retracts (vacuum increase) to adjust throttle angle for curb idle speeds.

The Idle Speed Control (ISC) and Idle Load Compensator (ILC) are adjusted at the factory. A special plunger head requires use of a special tool to turn it, this



is to discourage readjustment. NO ATTEMPT should be made to adjust the ISC or ILC unless, in diagnosis, curb idle speed is not to specification. (If adjustment is necessary, refer to "On-Vehicle" service.)

On vehicles that do not include an ISC or ILC but are equipped with air conditioning, an Idle Speed Solenoid (ISS) is used to maintain curb idle speed whenever the air conditioning compressor clutch is engaged (ISS solenoid energized by A/C switch).

The carburetor model identification number is stamped vertically on the float bowl, near the secondary throttle lever.

#### See Figure 6C1-1

Refer to the part number on the bowl when servicing the carburetor. When replacing the float bowl assembly, follow the instructions contained in the service package. Stamp or engrave the model number on the new float bowl.

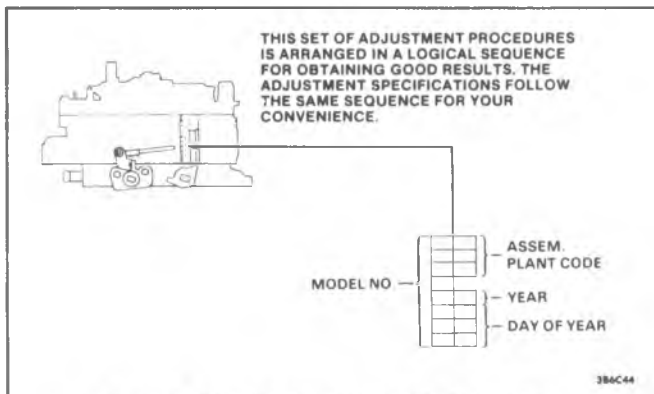

Figure 6C1-1 Carburetor Identification

## ON VEHICLE SERVICE

### FLOAT MECHANICAL LEVEL CHECK

See Figure 6C1-1A

### CHOKE CHECK PROCEDURE-ALL

Check unloader and idle setting adjustments.

Choke linkage and fast idle cam must operate freely. Bent, dirty, or otherwise damaged linkage must be cleaned, repaired, or replaced as necessary. Do not lubricate linkage since lubricant will collect dust and cause sticking.

### CHECKING ELECTRIC CHOKE

This check should be performed at an ambient temperature of 15° to 27°C (60° to 80°F).

1. Allow choke to cool so that when throttle is opened slightly, choke blade fully closes.
2. Start engine and determine time for choke blade to reach full open position. (Start timing when engine starts.)
3. If the choke blade fails to open fully within 3.5 minutes, proceed with Steps 4 and 5 below.
4. Check voltage at the choke heater connection (engine must be running):
  - a. If the voltage is approximately 12-15 volts, replace the electric choke unit.
  - b. If the voltage is low or zero, check all wires and connections. If any connections in the oil pressure switch circuitry are faulty, or if pressure switch is failed open, the oil warning light will be on with the engine running. Repair wires or connectors as required.

5. If Steps 4a and 4b do not correct the problem, replace oil pressure switch. No gasket is used between the choke cover and the choke housing due to grounding requirements.

### CHECKING HOT AIR CHOKE

1. With parking brake applied, drive wheels blocked, transmission in Park or Neutral, start engine and allow engine to warm up, visually checking to be certain choke valve opens fully.
2. If choke valve fails to open fully, momentarily touch choke housing and hot air inlet pipe or hose to determine if sufficient heat is reaching the choke coil.

**CAUTION: The choke housing and hot air inlet pipe or hose are "hot" to the touch. Use care to prevent burning of hands.**

If choke housing and/or heat inlet are cool to the touch, check for loss of vacuum to the housing, restricted heat inlet in the choke housing or choke heat pipe, collapsed or deteriorated heat inlet hose, or restricted passages in the manifold choke heat stove. Replace or correct as necessary.

See Figure 6C1-8A

### ON-CAR SPEED ADJUSTMENTS

#### Idle Speed Control (ISC) Adjustment

Prior to adjustment, check for an identification letter appearing on the ISC adjustment plunger, Figure 6C1-8C. If NO LETTER appears, using Tool J-29607, BT-8022 or equivalent, remove plunger from ISC unit. Then, measure length of plunger from back side of plunger head to end of plunger screw - Dimension "A" (Figure 6C1-8C). Record this measurement for use at Step 17. Reinstall plunger screw in ISC unit, turning plunger in to a preset position so that the distance measured from the back side of the plunger head to the ISC nosepiece is LESS THAN Dimension "B".

See Figure 6C1-8C

#### All Models

Before starting engine, place transmission selector lever in PARK (AUTO trans.) or NEUTRAL (MAN. trans.), set parking brake, and block drive wheels.

**NOTICE: DO NOT** disconnect or connect ISC connector with ignition "ON" as damage to the ECM may occur.

1. Prepare vehicle for adjustments - see Vehicle Emission Control Information Label.
2. Connect tachometer (distributor side of tach filter, if used).
3. Connect dwell meter to mixture control (M/C) solenoid dwell lead. Remember to set dwell meter on the six cylinder scale, regardless of the engine being tested.
4. Turn A/C "OFF".
5. Start engine and run until system enters "closed" loop (dwell meter needle starts to vary).
6. Turn ignition "OFF".
7. Unplug connector from ISC motor.
8. Fully retract ISC plunger by applying 12 volts to terminal "C" of the ISC motor connection and ground lead to terminal "D" of the ISC motor connection.

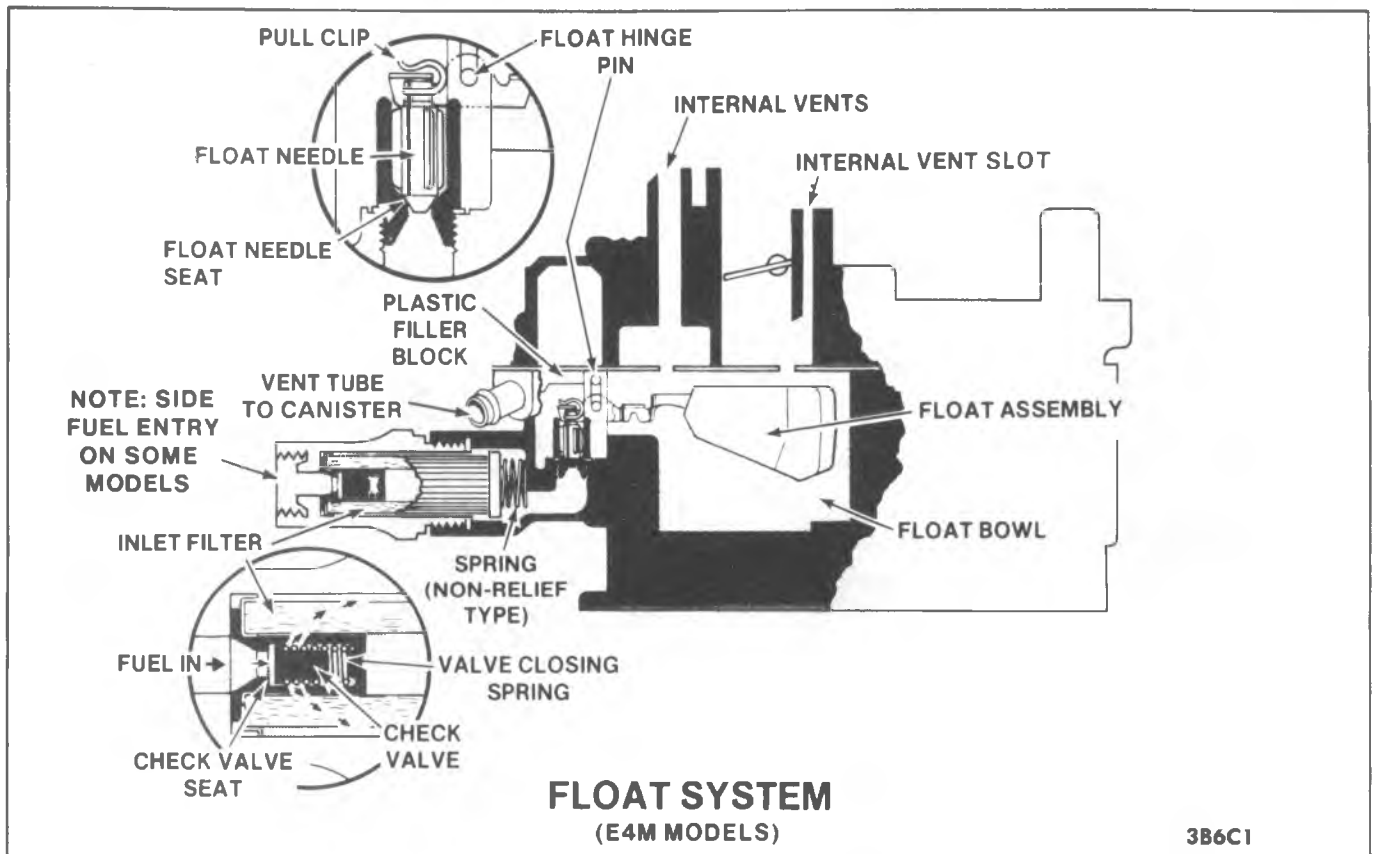

Figure 6C1-2 Float System

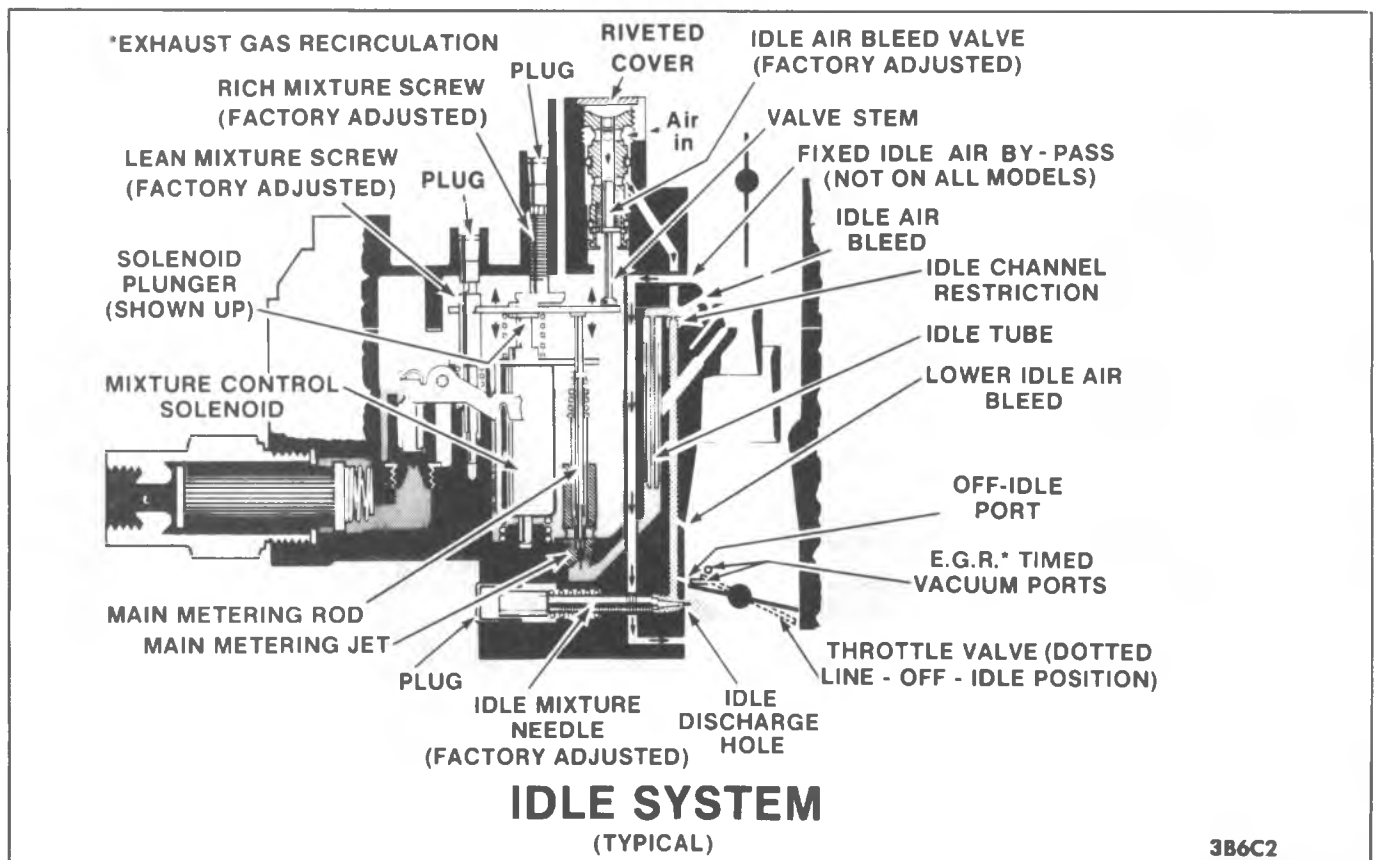

Figure 6C1-3 Idle System

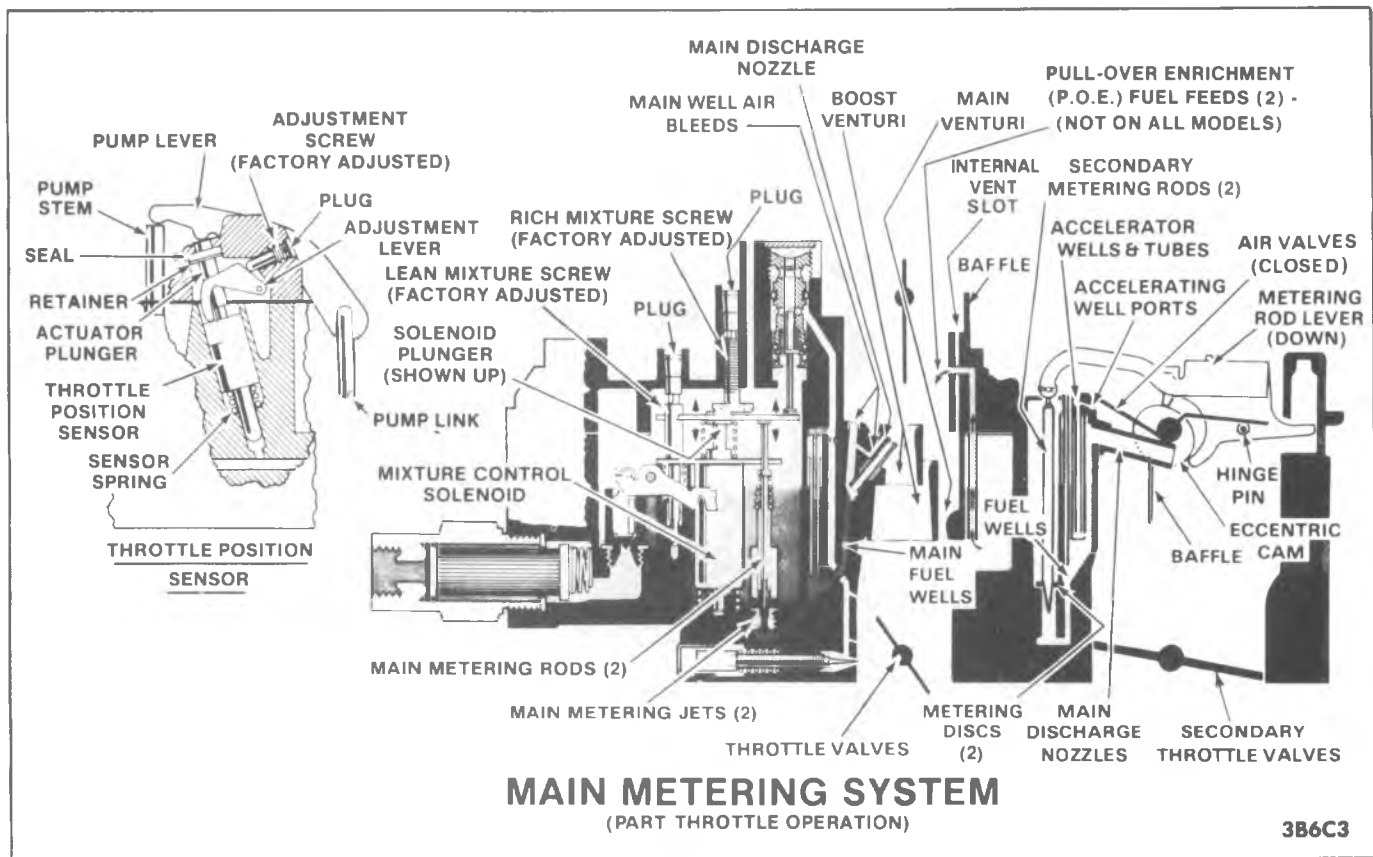

Figure 6C1-4 Main Metering System

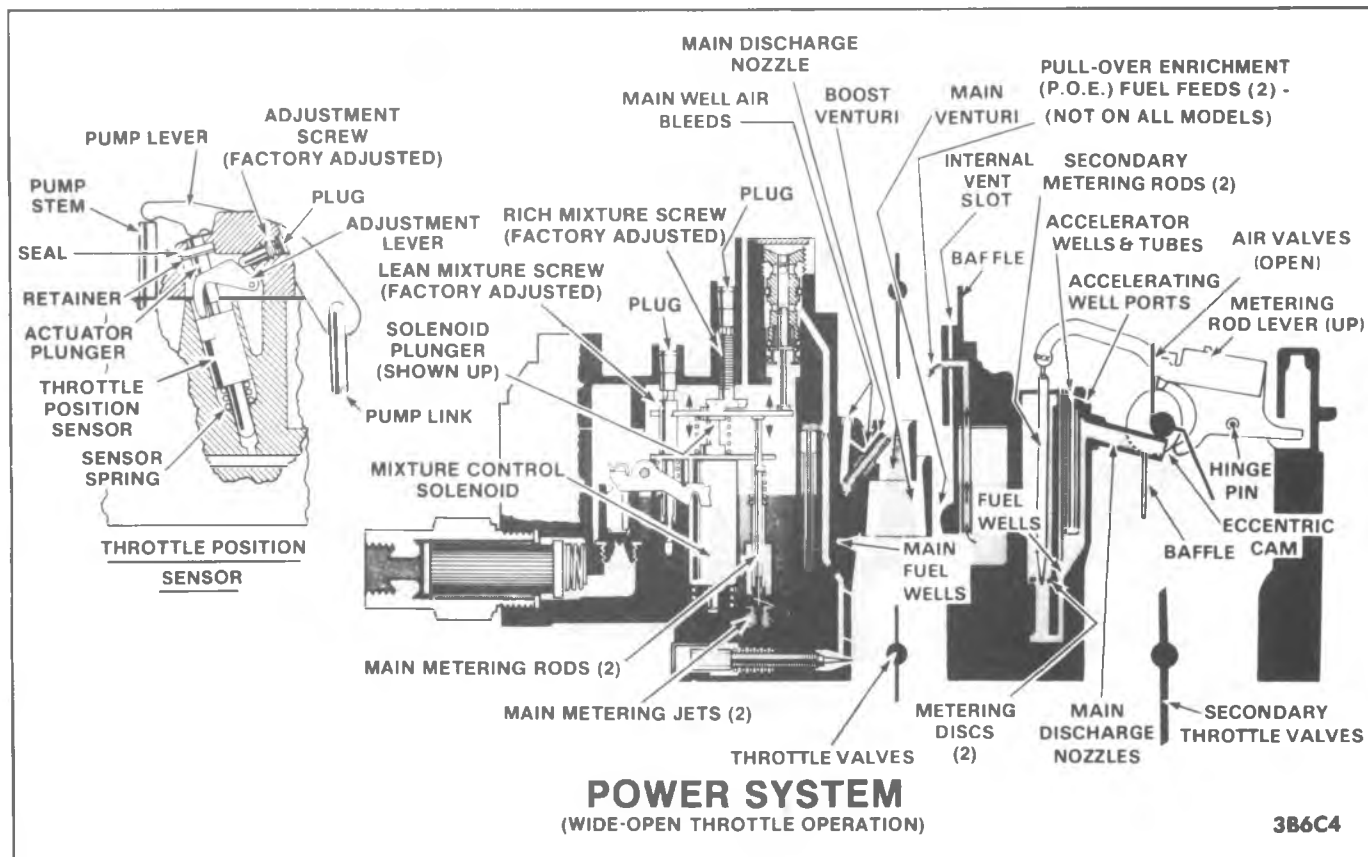

Figure 6C1-5 Power System

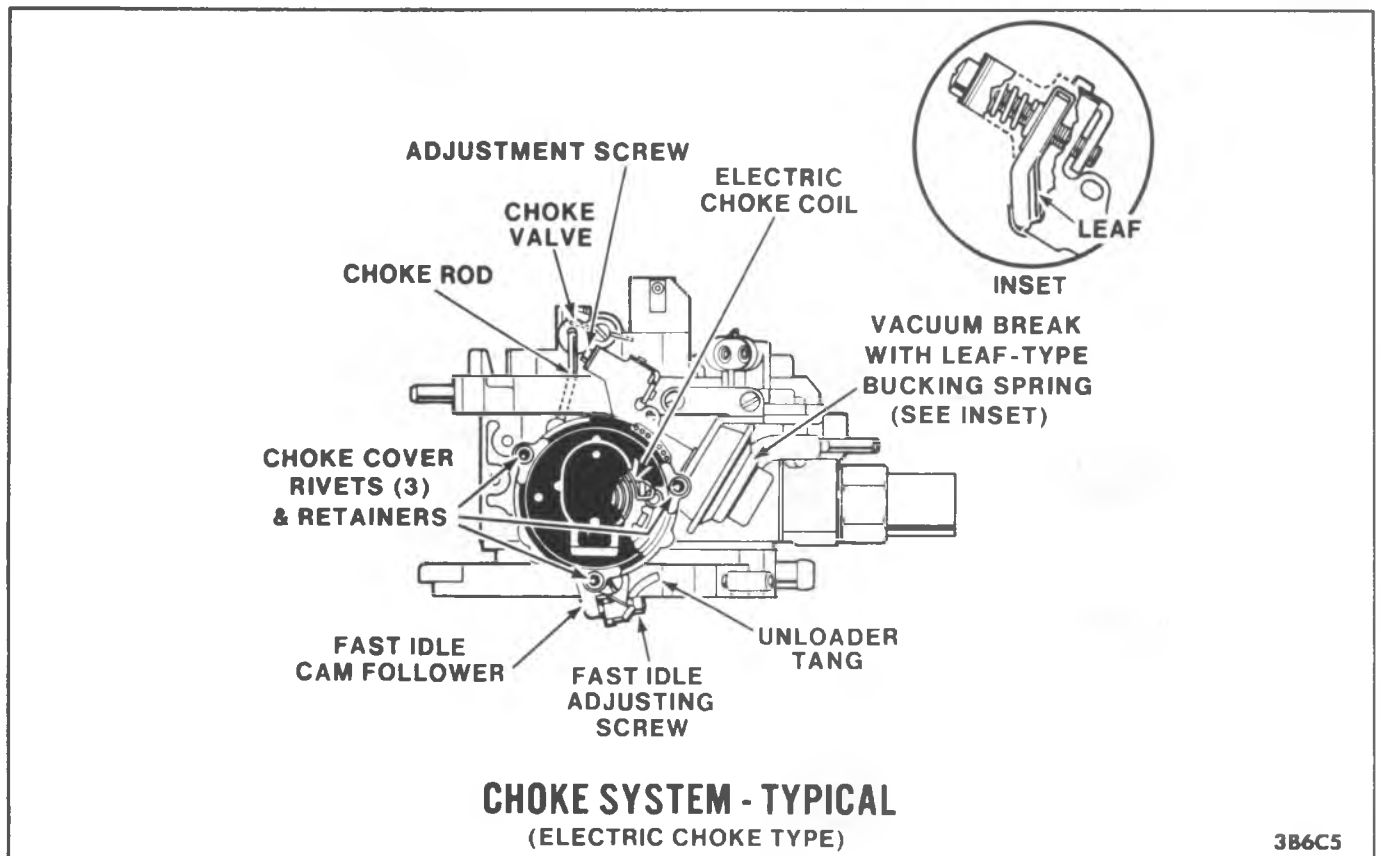

Figure 6C1-6 Pump System

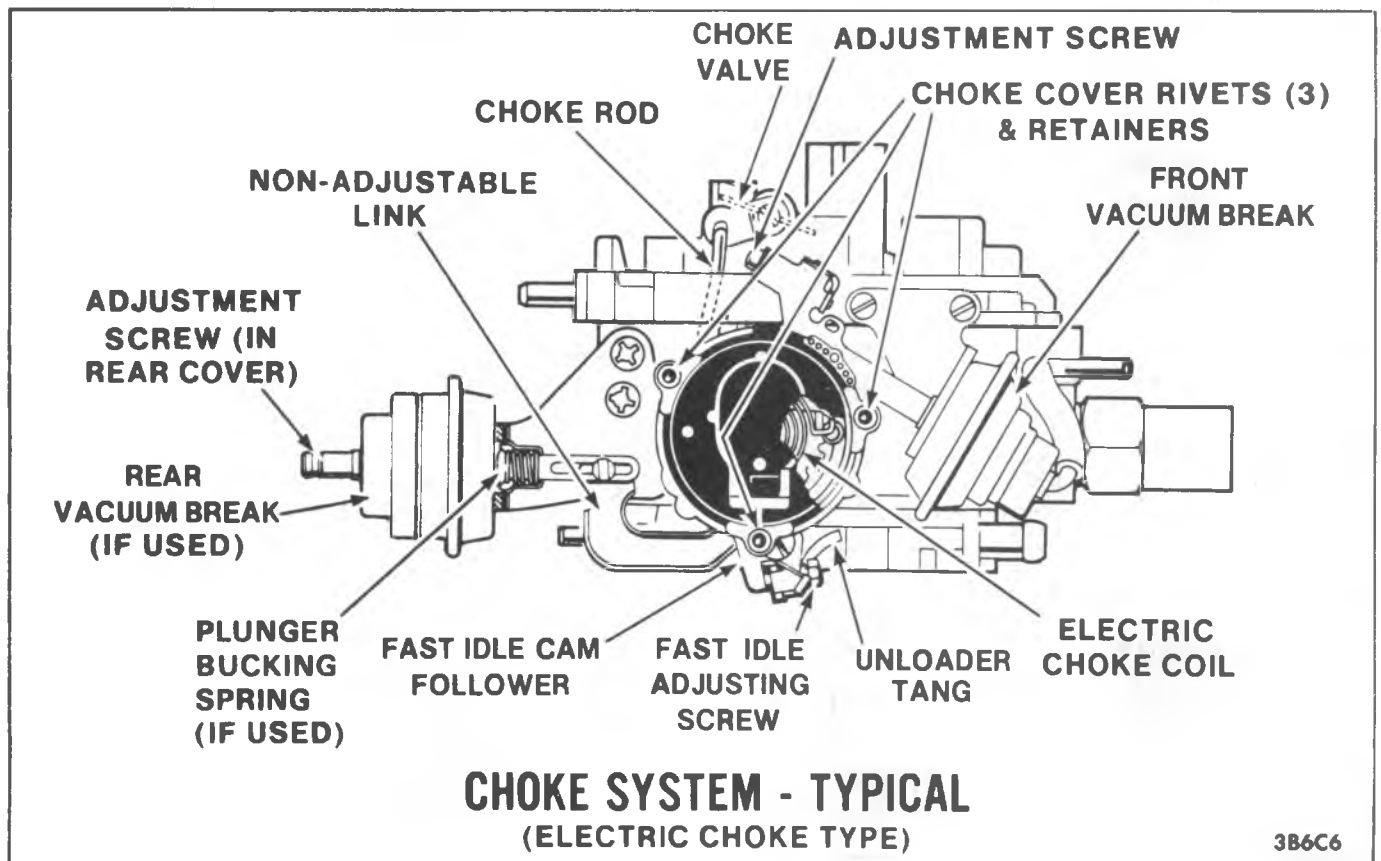

Figure 6C1-7 Choke System-E4ME (with Rear Vacuum Break)

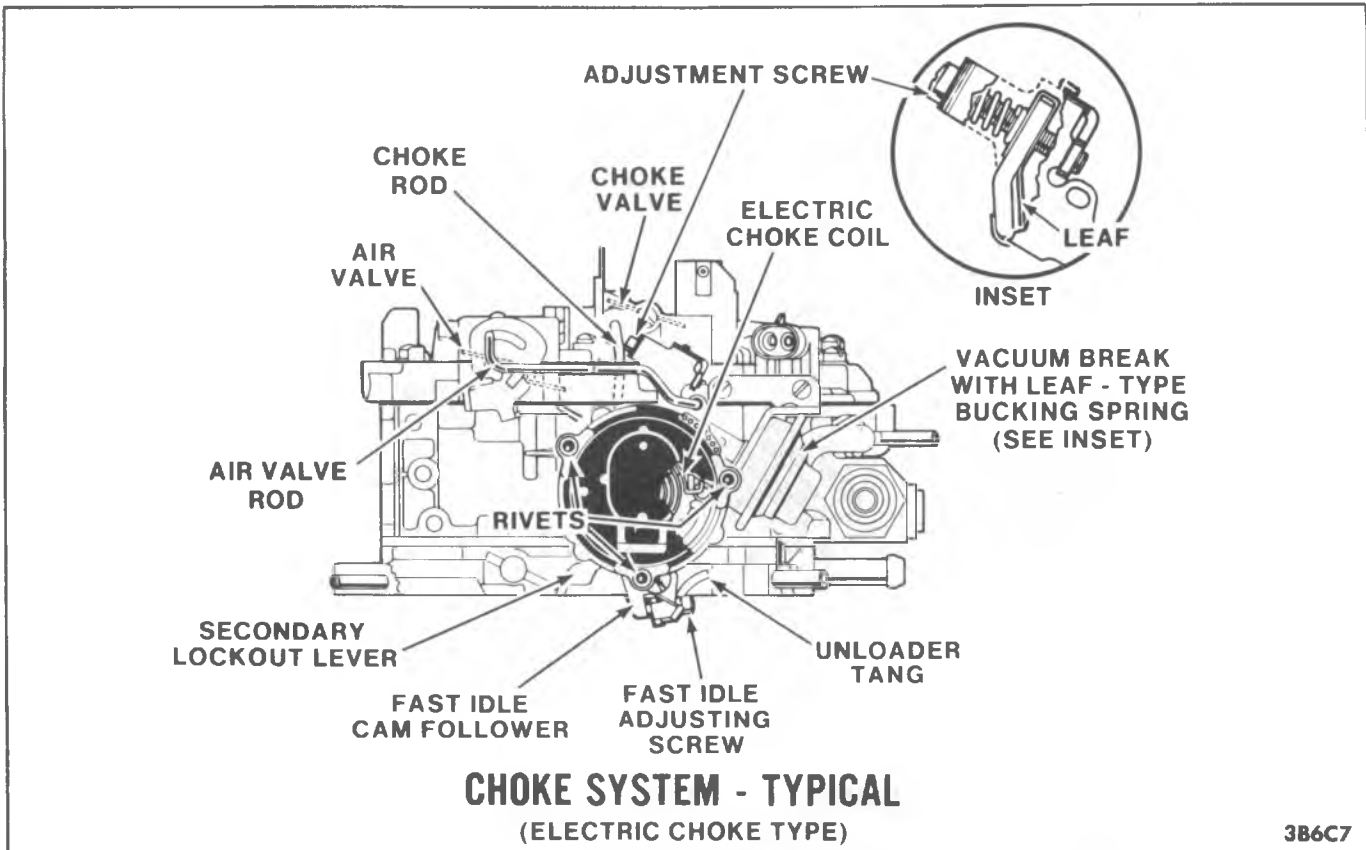

Figure 6C1-8 Choke System-E4ME (without Rear Vacuum Break)

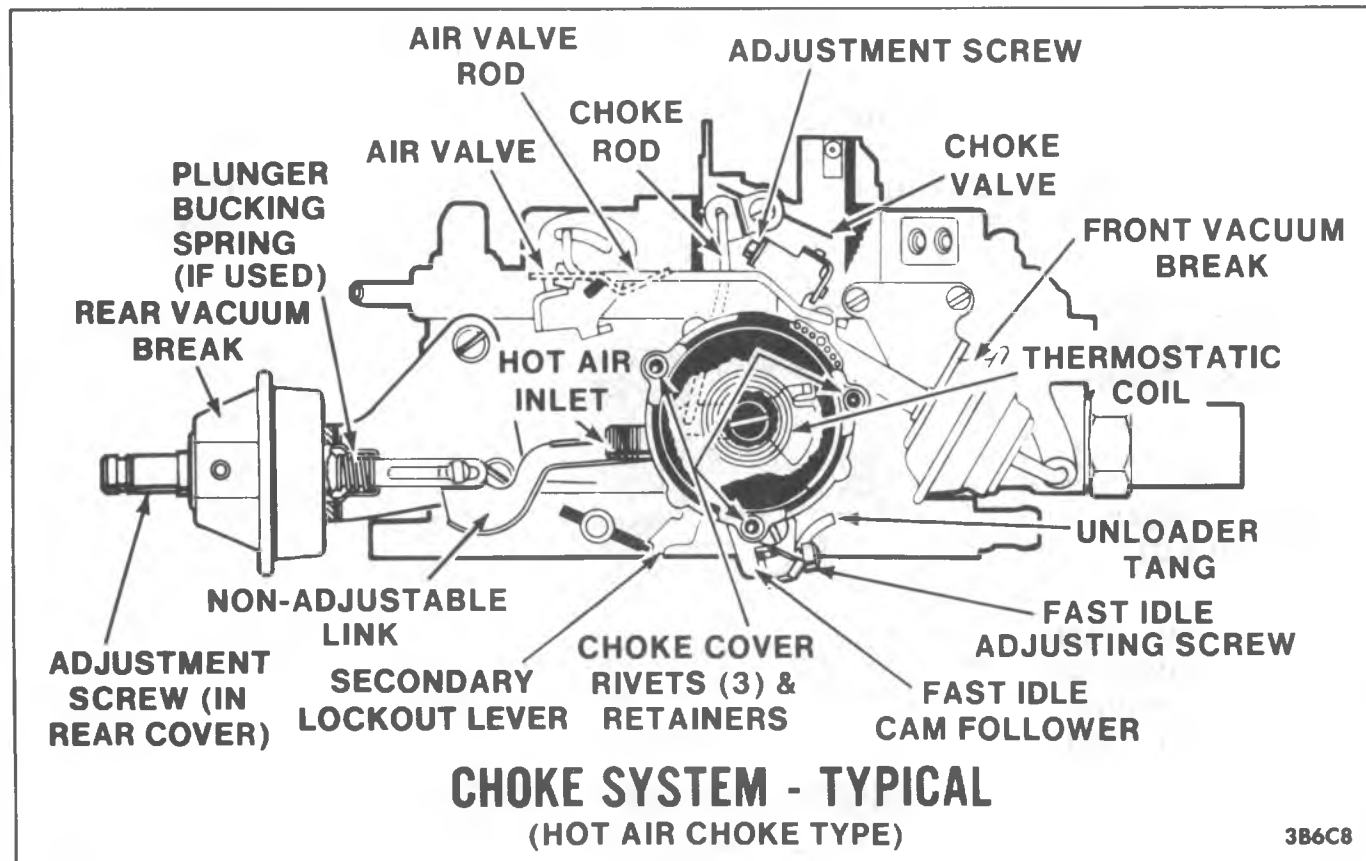

Figure 6C1-8A Choke System-E4MC

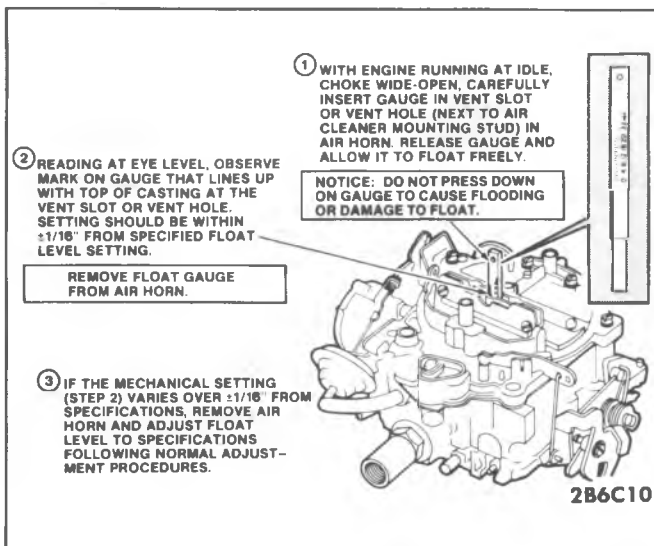

Figure 6C1-1A External Float Gage Check Procedure

**See Figure 6C1-8B**

**NOTICE:** DO NOT leave battery voltage applied to motor longer than necessary to retract ISC plunger. Prolonged contact will damage motor. Also, NEVER connect voltage source across terminals "A" and "B" as damaged to the internal throttle contact switch will result.

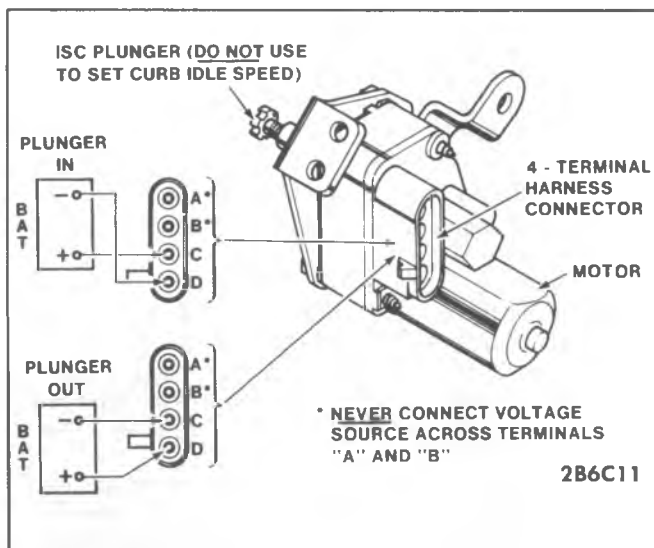

Figure 6C1-8B Idle Speed Control Assembly-Typical

9. Start engine and wait until dwell meter needle starts to vary, indicating "closed loop" operation.
10. With parking brake applied and drive wheels blocked, place transmission in drive (neutral-manual transmission models).
11. With ISC plunger fully retracted, adjust carburetor base (slow) idle stop screw (minimum authority) to the RPM shown in Figure 6C1-60.
12. PLACE TRANSMISSION IN PARK (AUTO TRANS.) OR NEUTRAL (MAN. TRANS.)
13. Fully extend ISC Plunger by applying 12 volts to Terminal "D" of the ISC Motor Connection and ground lead to Terminal "C" of the ISC Motor Connection. Leave power applied only long enough to extend the plunger.

**NOTICE:** Never connect voltage source across terminals "A" and "B" as damage to the internal throttle contact switch will result.

14. Manual transmission: Using Tool J-29607 or BT-8022 or equivalent, turn ISC Plunger to obtain ISC adjustment RPM (Maximum Authority) shown in Figure 6C1-60.
15. Automatic Transmission
  - a. With Transmission in Park, using Tool J-29607 or BT-8022 or equivalent, preset ISC plunger to obtain 1500 RPM.
  - b. With parking brake set and drive wheels blocked, place transmission in drive. Using Tool J-29607 or BT-8022 or equivalent, turn ISC Plunger to obtain ISC adjustment RPM (Maximum Authority) shown in Figure 6C1-60.
16. Recheck ISC Maximum Authority Adjustment RPM with voltage applied to Motor (Step 13). Motor will ratchet at full extension with power applied.
17. After adjustment of ISC plunger, measure distance from back side of plunger head to ISC nosepiece, Dimension "B", Figure 6C1-8C. Dimension must NOT exceed that shown by plunger type as either identified by plunger length or letter identification.

**See Figure 6C1-8D**

Figure 6C1-8C Plunger Maximum Adjustment

18. Fully retract ISC Plunger (Step 8). Place Transmission in Park (AUTO Trans.) or Neutral (MAN. Trans.) and turn ignition "Off". Disconnect 12 Volt Power source, Ground lead, Tachometer and Dwell Meter. With ignition "Off", reconnect four (4) Terminal Harness connector to ISC Motor.
19. "TRICKING" the ISC motor as described will cause the "CHECK ENGINE" light to come on and an ISC motor trouble code to be set. By restoring the system to normal operation, the light will go out, but the trouble code will continue to be stored as an "INTERMITTENT" problem. In this case, it will be necessary to clear the diagnostic trouble codes (See Section 6E for procedure).
20. Remove block from drive wheels.

**Idle Load Compensator (ILC) Adjustment - E4MC**

1. Prepare vehicle for adjustments - see Vehicle Emission Control Information Label.
2. Connect tachometer (distributor side of TACH filter, if used.).
3. Remove air cleaner and plug vacuum hose to Thermal Vacuum Valve (TVV).

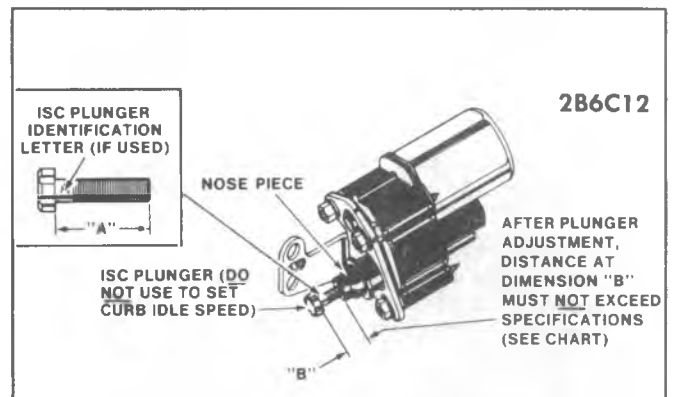
| IDLE SPEED CONTROL PLUNGER |                            |   |
|----------------------------|----------------------------|---|
| IDENTIFICATION LETTER      | PLUNGER LENGTH DIMENSION A | AFTER ADJUSTMENT (STEPS 14, 15, or 16), DISTANCE AT DIMENSION "B" MUST NOT EXCEED |
| NONE                       | 14.1 mm (9/16")            | 5.6 mm (7/32")  |
| NONE                       | 16.3 mm (41/64")           | 8.0 mm (5/16")  |
| X                          | 18.5 mm (47/64")           | 10.0 mm (25/64")  |
| A                          | 19.3 mm (49/64")           | 10.8 mm (27/64")  |
| Y                          | 20.5 mm (51/64")           | 12.0 mm (15/32")  |
| S                          | 21.2 mm (27/32")           | 12.7 mm (1/2")  |
| Z                          | 22.5 mm (7/8")             | 14.0 mm (35/64")  |
| G                          | 23.2 mm (29/32")           | 14.7 mm (37/64")  |
| E                          | 25.6 mm (1")               | 17.1 mm (43/64")  |
| L                          | 27.5 mm (1 3/32")          | 19.0 mm (3/4")  |
| J                          | 30.0 mm (1 3/16")          | 21.5 mm (27/32")  |
| N                          | 32.0 mm (1 17/64")         | 23.5 mm (59/64")  |
| T                          | 34.0 mm (1 11/32")         | 25.5 mm (1")  |

Figure 6C1-8D Plunger Maximum Adjustment Chart

4. Disconnect and plug vacuum hose to EGR.
  5. Disconnect and plug vacuum hose to canister purge port.
  6. Disconnect and plug vacuum hose to ILC.
  7. Back out idle stop screw on carburetor 3 turns.
  8. Turn A/C "OFF".
- BEFORE STARTING ENGINE, PLACE TRANSMISSION IN PARK, SET PARKING BRAKE, AND BLOCK DRIVE WHEELS.
9. With engine running (engine warm, choke off), transmission in drive, and ILC plunger fully extended (no vacuum applied). Using Tool J-29607, BT-8022 or equivalent, adjust plunger to obtain 725 RPM E4MC models - Figure 6C1-14. Jam nut on plunger must be held with wrench to prevent damage to guide tabs.

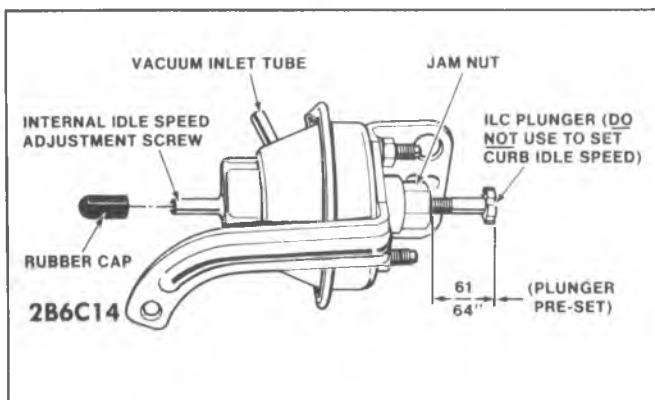

Figure 6C1-8E Idle Load Compensator (ILC)-Typical

10. Remove plug from vacuum hose, reconnect hose to ILC and observe idle speed. Idle speed should be 500 RPM in drive.

11. IF SPEED IS CORRECT (STEP 10) NO FURTHER ADJUSTMENT OF ILC IS NECESSARY. PROCEED TO STEP 13.
12. IF SPEED IS NOT CORRECT (STEP 10)
  - a. Stop engine and remove the ILC. Plug vacuum hose to ILC.
  - b. With the ILC removed, remove the rubber cap from the center outlet tube and then remove the metal plug (IF USED) from this same tube.
  - c. Install ILC on carburetor and reattach throttle return spring and any other related parts removed during disassembly. Remove plug from vacuum hose and reconnect hose to ILC.
  - d. Using a spare rubber cap with hole punched to accept a .090" (3/32") hex key wrench, install cap on center wrench through cap to engage adjusting screw inside tube. Start engine and turn adjusting screw with wrench to obtain 500 RPM in drive. Turning the adjusting screw will change the idle speed approximately 75-100 RPM for each complete turn. Turning the screw counterclockwise will increase the engine speed.
  - e. Remove wrench and cap (with hole) from center outlet tube and install new rubber cap.
  - f. Engine running, transmission in drive, measure distance from the jam nut to tip of the plunger, Dimension "A", Figure 6C1-13. Dimension must NOT exceed 25mm (1 inch).
14. Disconnect and plug vacuum hose to ILC. Apply vacuum source such as hand vacuum pump J-23768, BT-7517 or equivalent to ILC vacuum inlet tube to fully retract the plunger.
15. Adjust the idle stop screw on the carburetor float bowl to obtain 500 RPM in drive.
16. Place transmission in PARK and stop engine.



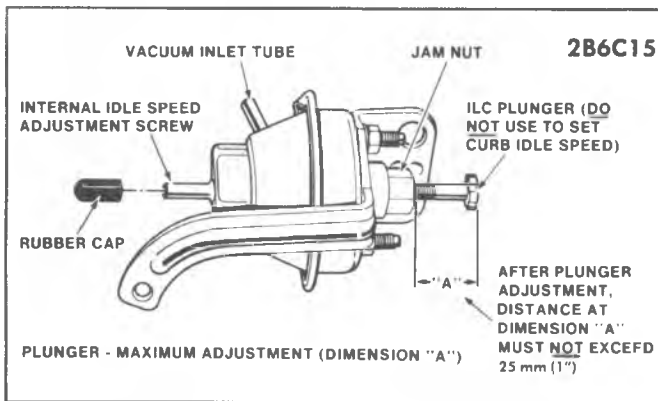

Figure 6C1-8F ILC Plunger - Maximum Adjustment

17. Remove plug from vacuum hose and install hose on ILC vacuum inlet tube.
18. Remove plug and reconnect all vacuum hoses.
19. Install air cleaner and gasket.
20. Remove block from drive wheels.

### Differential Vacuum Delay Valve (DVDV)

The DVDV is located in the vacuum line between the Idle Load Compensator (ILC) and the vacuum source. It is used on all 5.0L engines (engine code Y).

See Figure 6C1-8G

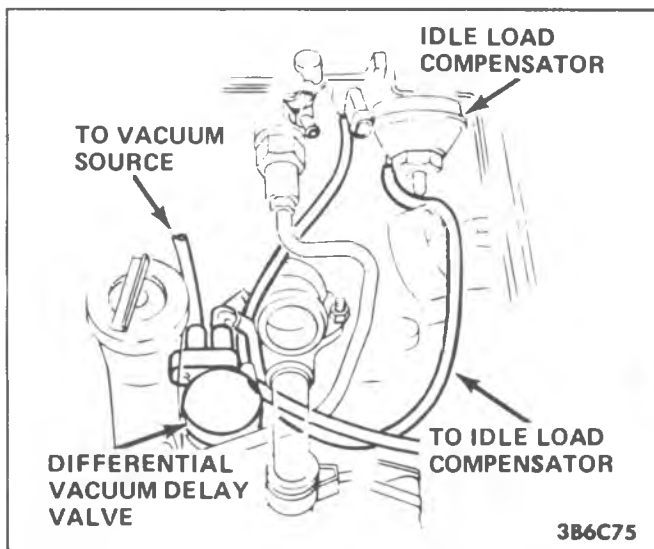

Figure 6C1-8G DVDV Hose Routing

The DVDV acts as cushioning device by slightly delaying the operation of the ILC until a constant vacuum change has occurred. Without the DVDV the ILC would react too quickly to changes in engine vacuum, causing a surging condition or if too restrictive to vacuum flow, it would cause a stalling or run-on condition.

To check the operation of the DVDV, install a vacuum gage with a "T" into the hose from the DVDV to the ILC. Install a vacuum pump to port 1 (Figure 6C1-8H) and apply 60 kPa (17.8") of vacuum while watching the other vacuum gage, it should take six (6) to nine (9) seconds for the vacuum to rise to 57.0 kPa (16.9"). Remove the vacuum gage with "T", install the vacuum pump to port 2 and leave port 1 open. Air should flow through the valve after 1.7 kPa (.5") is applied.



Figure 6C1-8H Differential Vacuum Delay Valve

### A/C Idle Speed Solenoid (ISS) Adjustment

See Figure 6C1-8I for Idle Speed Solenoid (ISS Adjustment)

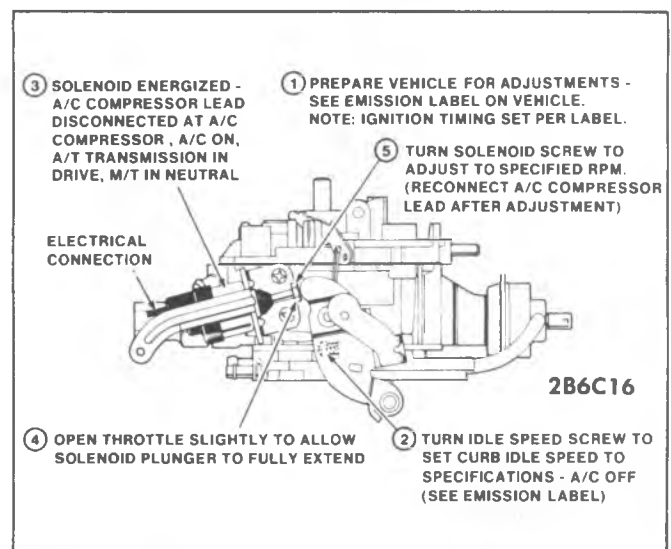

Figure 6C1-8I Idle Speed Solenoid Adjustment

### Throttle Position Sensor (TPS) Adjustment

The plug covering the TPS adjustment screw is used to provide a tamper-resistant design and retain the factory setting during vehicle operation. DO NOT REMOVE the plug unless, in diagnosis, the "System Performance Check" (Section 6E1) indicates the TPS Sensor is not adjusted correctly or it is necessary to replace the air horn assembly, float bowl, TPS sensor, or TPS adjustment screw. This is a critical adjustment that must be performed accurately to ensure proper vehicle performance and control of exhaust emissions.

If necessary to adjust the TPS sensor:

1. Using a 2mm (5/64") drill, drill a 1/16" to 1/8" deep hole in aluminum plug covering TPS adjustment screw. Use care in drilling to prevent damage to adjustment screw head.

See Figure 6C1-8J

2. Start a No. 8 1/2" long self-tapping screw in drilled hole turning screw in only enough to ensure good thread engagement in hole.
3. Placing a wide-blade screwdriver, between screw head and air horn casting, pry against screw head to remove plug. DISCARD PLUG.
4. Using Tool J-28696 or equivalent, remove TPS adjustment screw.



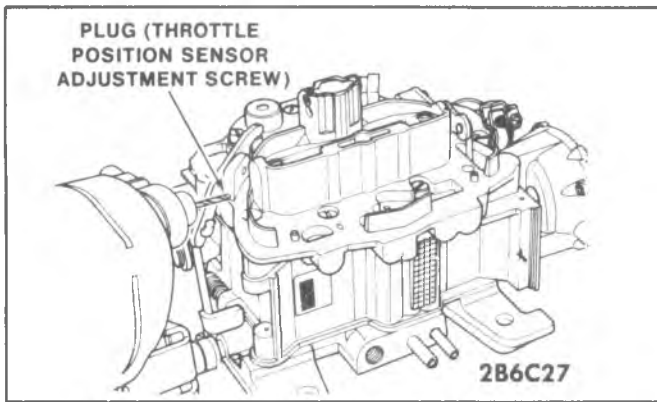

Figure 6C1-8J TPS Adjustment Screw Plug

See Figure 6C1-8I

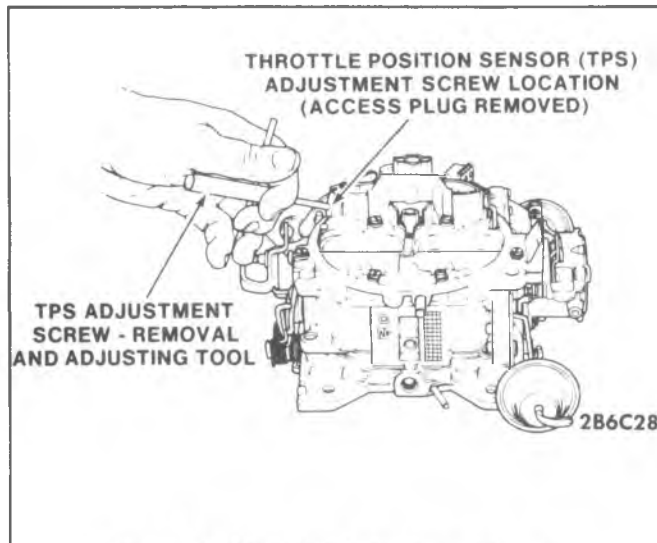

Figure 6C1-8K TPS Adjustment Screw

5. Connect digital voltmeter (such as J-29125) from TPS connector center terminal (B) to bottom terminal (C). (Jumpers for access can be made using terminals 12014836 and 12014837.)
6. With ignition on, engine stopped, reinstall TPS adjustment screw and with Tool J-28696, BT-7967A or equivalent quickly adjusting screw to obtain specified TPS voltage with A/C off.

See Specifications Figure 6C1-60

7. After adjustment, install new plug (supplied in service kits) in air horn, driving plug in place until flush with raised pump lever boss on casting.

**NOTICE:** Plug must be installed to retain the TPS adjustment screw setting. If plug is not available, remove screw and apply Delco Threadlock Adhesive X-10 or equivalent to screw threads then, repeat Step 6.

## Mixture Control Solenoid Plunger Travel

### Checking

Mixture control solenoid plunger travel should be checked before proceeding with any carburetor adjustments or disassembly.

Using Float Gage J-9789-130, BT-7720, or equivalent, (used to check float level setting externally), insert gage in the vertical "D" shaped vent hole in the air horn casting, next to the Idle Air Bleed Cover, Figure 6C1-9. It may be necessary to file or grind material off the gage to allow it to enter the vent hole freely. Gage will be used to check total mixture control solenoid plunger travel.

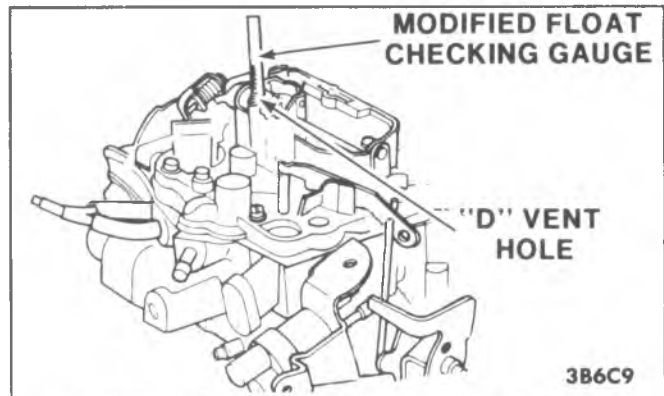

Figure 6C1-9 Checking Solenoid Plunger Travel

With engine off, air cleaner and gasket removed, measure mixture control solenoid plunger travel as follows:

1. Insert float gage down "D" shaped vent hole. Press down on gage and release, observing that the gage moves freely and does not bind. With gage released, (plunger UP position), read at eye level and record the reading of the gage mark (in inches) that lines up with the top of air horn casting, (upper edge).
2. Lightly press down on gage until bottomed, (plunger DOWN position). Read and record (inches) the reading of the gage mark that lines up with top of air horn casting.
3. Subtract gage UP position (Step 1) from gage DOWN position (Step 2), and record difference. This difference is total plunger travel.
4. If total plunger travel (Step 3) is between  $2/32$ " and  $6/32$ ", proceed to Idle Air Bleed Valve Adjustment. If it is less than  $2/32$ " or greater than  $6/32$ ", make mixture control solenoid plunger adjustments indicated below.

### Adjustments

1. Remove air horn, mixture control solenoid plunger, air horn gasket and plastic filler block, using normal service procedures.
2. Remove throttle side metering rod. Install mixture control solenoid gaging Tool J-33815-1, BT-8253-A, or equivalent, over the throttle side metering jet rod guide, and temporarily reinstall the solenoid plunger into the solenoid body.

See Figure 6C1-10

3. Holding the solenoid plunger in the DOWN position, use Tool J-28696-10, BT-7928, or equivalent, to turn lean mixture (solenoid) screw counterclockwise until the plunger breaks contact with the gaging tool. The adjustment is correct when the solenoid plunger is contacting BOTH the SOLENOID STOP and the GAGING TOOL.

See Figure 6C1-11

If the total difference in adjustment required less than  $3/4$  turn of the lean mixture (solenoid) screw, the original setting was within the manufacturer's specifications.

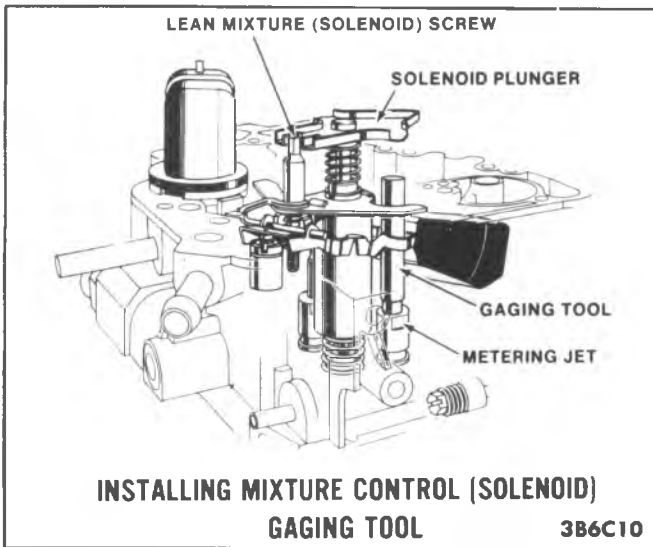

**INSTALLING MIXTURE CONTROL (SOLENOID) GAGING TOOL** 3B6C10  
 Fig. 6C1-10 Installing Mixture Control Solenoid Gaging Tool

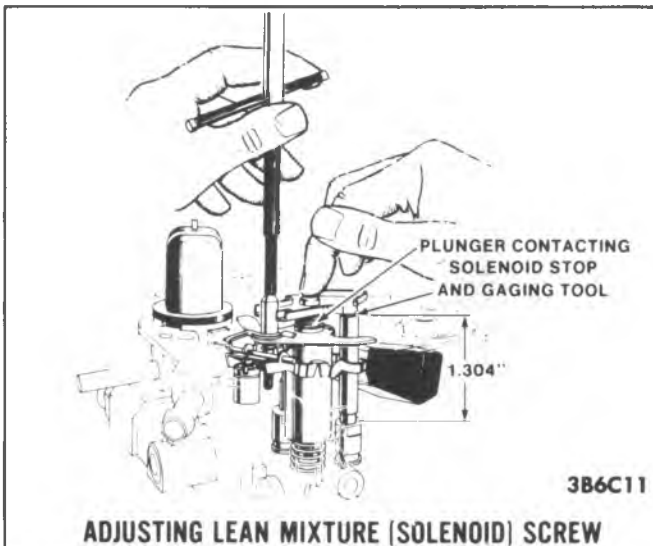

**ADJUSTING LEAN MIXTURE (SOLENOID) SCREW** 3B6C11  
 Figure 6C1-11 Adjusting Lean Mixture (Solenoid) Screw

4. Remove solenoid plunger and gaging tool, and reinstall metering rod and plastic filler block.
5. Invert air horn, and remove rich mixture stop screw from bottom side of air horn, using Tool J-28696-4, BT-7967A or equivalent.

See Figure 6C1-12

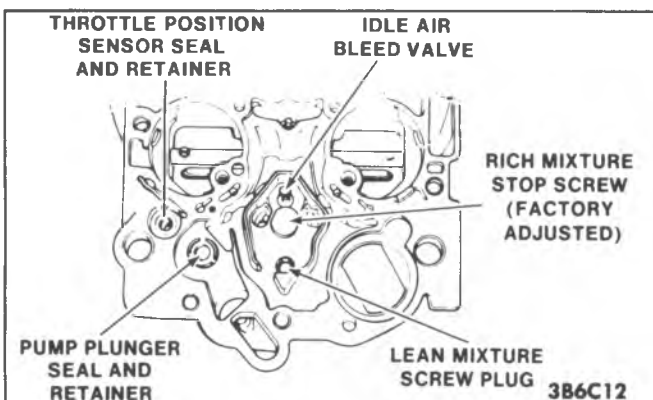

**REMOVING RICH MIXTURE STOP SCREW** 3B6C12  
 Figure 6C1-12 Removing Rich Mixture Stop Screw

6. Remove lean mixture screw plug and the rich mixture stop screw plug from air horn, using a suitably sized punch.

See Figure 6C1-13

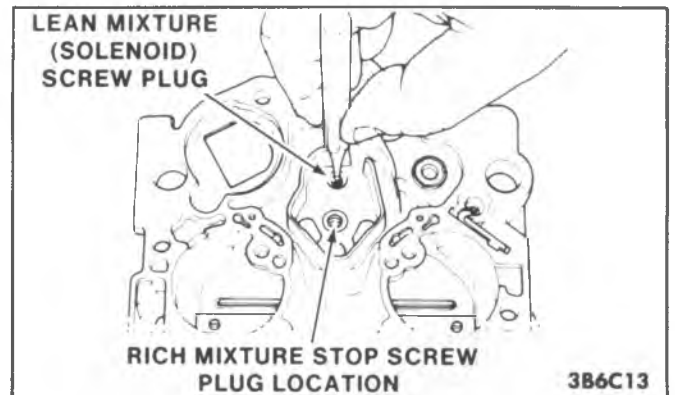

**REMOVING LEAN MIX. SCREW & RICH MIX. STOP SCREW PLUGS** 3B6C13  
 Figure 6C1-13 Removing Lean Mix. Screw & Rich Mix. Stop Screw Plugs

7. Reinstall rich mixture stop screw in air horn and bottom lightly, then back screw out 1/4 turn.
8. Reinstall air horn gasket, mixture control solenoid plunger and air horn to carburetor.
9. Insert external float gage in vent hole and, with Tool J-9789-130, BT-7220, or equivalent, adjust rich mixture stop screw to obtain 4/32" total plunger travel.

See Figure 6C1-14

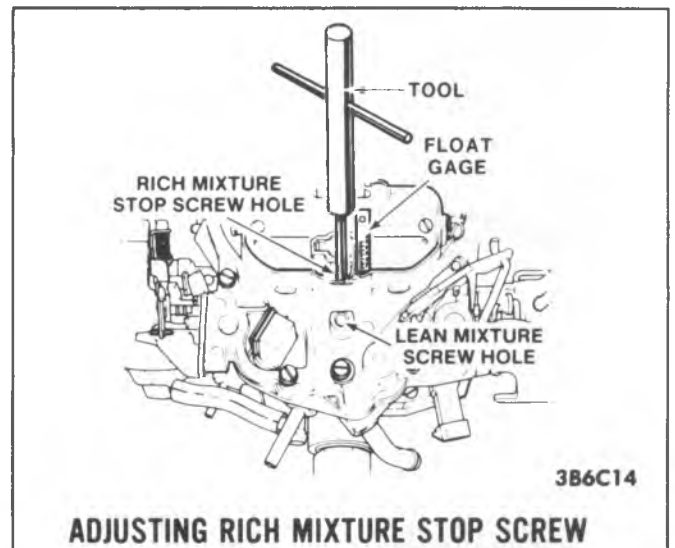

**ADJUSTING RICH MIXTURE STOP SCREW** 3B6C14  
 Figure 6C1-14 Adjusting Rich Mixture Stop Screw

10. With solenoid plunger travel correctly set, install plugs (supplied in service kits) in the air horn, as follows:
  - a. Install plug, hollow end down, into the access hole to lean mixture (solenoid) screw, and use suitably sized punch to drive plug into the air horn until the top of the plug is even with the lower edge of the hole chamfer. Plug must be installed to retain the screw setting and to prevent fuel vapor loss.

See Figure 6C1-15

- b. Install plug, with hollow end down, over the rich mixture stop screw access hole, and drive plug into place so that the top of the plug is 1/16" below

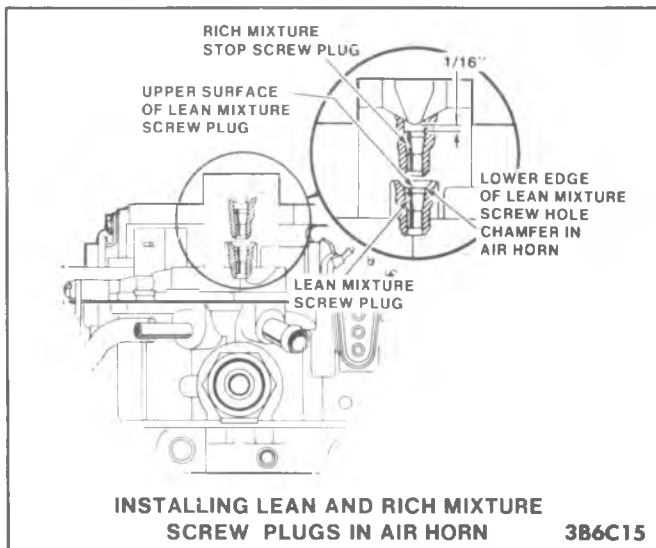

Figure 6C1-15 Installing Lean & Rich Mix. Stop Screw Plugs

the surface of the air horn casting. Plug must be installed to retain screw setting.

See Figure 6C1-15

### Idle Mixture and Speed Adjustment

A cover is riveted in place over the idle air bleed valve, and the access holes to the idle mixture needles are sealed with hardened plugs, to seal the factory settings, during original equipment production. These items are NOT to be removed unless required for cleaning, part replacement, improper dwell readings (Step 4, below), or if the System Performance Check (Section 6E1) indicates the carburetor is the cause of the trouble.

#### Idle Mixture

##### Adjustment

1. Before proceeding:
  - a. Set Parking brake and block drive wheels.
  - b. Disconnect and plug hoses, as directed on Emission Control Information Label under the hood.
  - c. Check ignition timing as shown on the Emission Control Information label.
  - d. Connect dwell meter and tachometer as noted in "System Performance Check" chart in Section 6E1.
2. Start engine, and with transmission in Park or Neutral, run engine at idle until fully warm and a varying dwell is noted on the dwell meter. It is essential that the engine is operated for a sufficient length of time to ensure that the engine coolant and the oxygen sensor in the exhaust, are at full operational temperature.
3. Check engine idle speed and compare to specifications on the underhood label. If necessary, adjust curb idle speed. On models with Idle Speed Control (ISC) or Idle Load Compensator (ILC), no curb idle adjustment is possible as curb idle speed is controlled by ECM. If speed is out of specification, refer to appropriate section for correct setting procedure.
4. With engine idling in Drive (Neutral for manual transmission), observe dwell reading on the 6 cylinder scale. If varying within the 10-50° range, adjustment is correct. If NOT, perform the following:
5. **IDLE AIR BLEED VALVE COVER REMOVAL**

To gain access to the idle air bleed valve for identification, adjustment or servicing, it is necessary to remove the idle air bleed valve cover.

- a. With engine off, cover internal bowl vents and air inlets to the bleed valve with masking tape or equivalent. Cover carburetor air intakes with masking tape to prevent metal chips from entering carburetor and engine.
- b. Carefully align a No. 35 (.110") drill bit on one of the steel rivet heads holding the idle air bleed valve cover in place. Drill only enough to remove rivet head.

See Figure 6C1-16

Drill the remaining rivet head located on the other side of the tower. Use a drift and small hammer to drive the remainder of the rivets out of the idle air bleed valve tower in the air horn casting. Use care in drilling to prevent damage to the air horn casting.

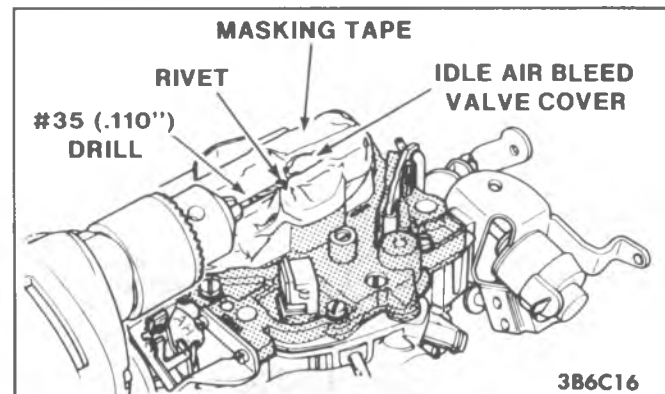

Figure 6C1-16 Removing Idle Air Bleed Cover Rivets

- c. Lift out cover over the idle air bleed valve and remove the rivet pieces from inside the idle air bleed valve tower.

**CAUTION: For the next operation, safety glasses must be worn to protect the eyes from possible metal shaving damage.**

Using shop air, carefully blow out any remaining chips from inside the tower. **DISCARD COVER AFTER REMOVAL.** A missing cover indicates that the idle air bleed valve setting has been changed from its original factory setting.

- d. With cover removed, look for presence (or absence) of a letter identification on top of idle air bleed valve.

See Figure 6C1-17

If NO identifying letter appears on top of the valve, begin PROCEDURE A, below. If the valve IS identified with a letter, begin PROCEDURE B.

#### Procedure A (No Letter on Idle Air Bleed Valve)

1. **PRESETTING THE IDLE AIR BLEED VALVE** to a gage dimension if the idle air bleed valve was serviced prior to on-vehicle adjustment.  
(Only necessary if idle air bleed valve was serviced prior to on-vehicle adjustment):
  - a. Install idle air bleed valve gaging Tool J-33815-2, BT-8253-B, or equivalent, in throttle side "D" shaped vent hole in the air horn casting. The upper

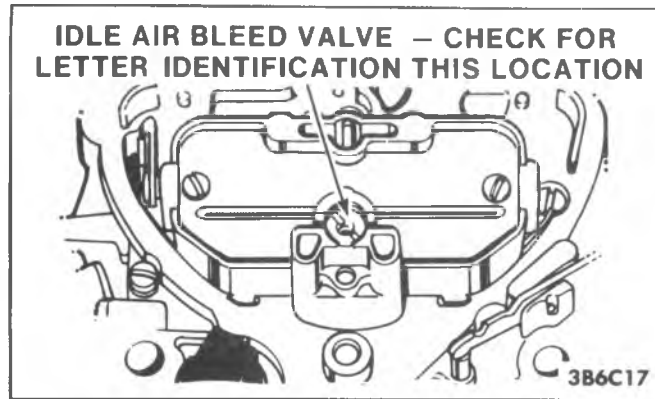

Figure 6C1-17 Idle Air Bleed Valve-Letter ID Location

end of the tool should be positioned over the open cavity next to the idle air bleed valve.

See Figure 6C1-18

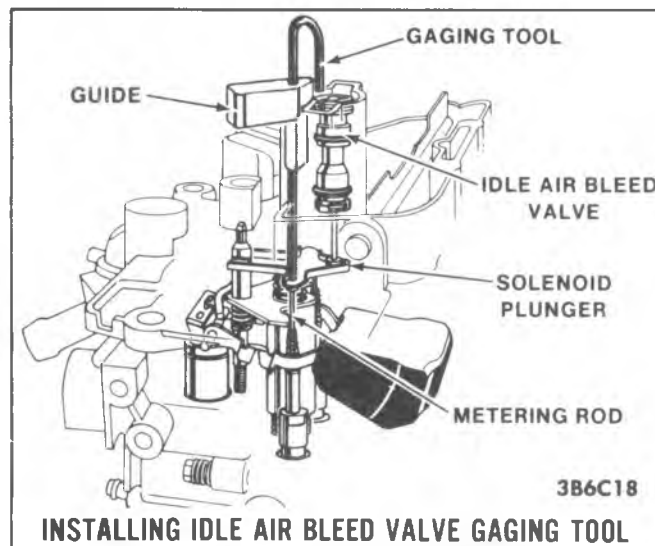

Figure 6C1-18 Installing Idle Air Bleed Valve Gaging Tool

- b. While holding the gaging tool down lightly, so that the solenoid plunger is against the solenoid stop, adjust the idle air bleed valve so that the gaging tool will pivot over and just contact the top of the valve. The valve is now preset for on-vehicle adjustment.

See Figure 6C1-19

- c. Remove gaging tool.
2. **ADJUSTING THE IDLE AIR BLEED VALVE** on the vehicle to obtain correct dwell reading.
- Start engine and allow it to reach normal operating temperature.
  - While idling in Drive (Neutral for manual transmission), use a screwdriver to slowly turn valve counterclockwise or clockwise, until the dwell reading varies within the 25-35° range, attempting to be as close to 30° as possible. Perform this step carefully. The air bleed valve is very sensitive and should be turned in 1/8 turn increments only.
  - If, after performing Steps a and b above, the dwell reading does not vary and is not within the 25-35° range, it will be necessary to remove the plugs and to adjust the idle mixture needles.

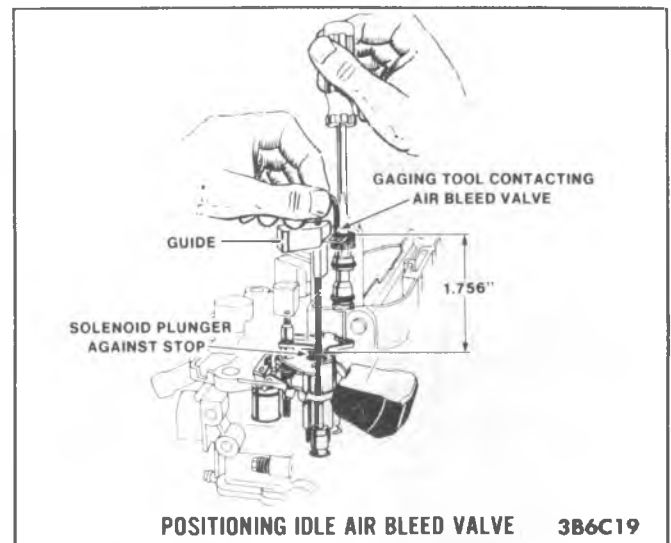

Figure 6C1-19 Positioning Idle Air Bleed Valve

**IDLE MIXTURE NEEDLE PLUG REMOVE**  
-- only if necessary:

- Remove the carburetor from the engine, following normal service procedures, to gain access to the plugs covering the idle mixture needles.
- Invert carburetor and drain fuel into a suitable container.
- Place carburetor on a suitable holding fixture, with manifold side up. Use care to avoid damaging linkage, tubes, and parts protruding from air horn.
- Make two parallel cuts in the throttle body, one on each side of the locator points beneath the idle mixture needle plug (manifold side), with a hacksaw.

See Figure 6C1-20

The cuts should reach down to the steel plug, but should not extend more than 1/8" beyond the locator points. The distance between the saw cuts depends on the size of the punch to be used.

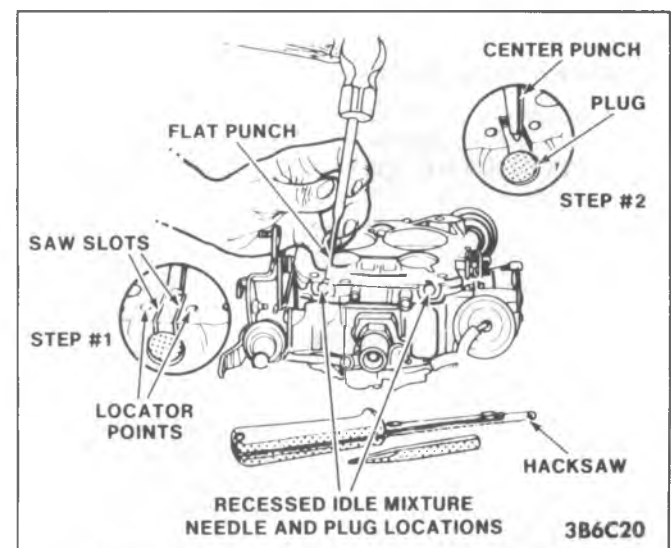

Figure 6C1-20 Removing Idle Needle Plugs

5. Place a flat punch near the ends of the saw marks in the throttle body. Hold the punch at a 45° angle and drive it into the throttle body until the casting breaks away, exposing the steel plug.  
The hardened plug will break, rather than remaining intact. It is not necessary to remove the plug in one piece, but remove the loose pieces.
6. Repeat this procedure with the other mixture needle.

3. **SETTING THE IDLE MIXTURE NEEDLES (IF NECESSARY)** where correct dwell reading could not be obtained with idle air bleed valve adjustment.

- a. Using Tool J-29030-B, BT-7610B, or equivalent, turn both idle mixture needles clockwise until they are lightly seated, then turn each mixture needle counterclockwise the number of turns specified.
- b. Reinstall carburetor on engine using a new flange mounting gasket, but do not install air cleaner and gasket at this time.

4. **READJUSTING IDLE AIR BLEED VALVE** to finalize correct dwell reading.

(Only necessary if idle mixture needles required setting in Step (3), above).

- a. Start engine and run until fully warm, and repeat "ADJUSTING THE AIR BLEED VALVE!", Step (2), above.
- b. If unable to set dwell to 25-35°, and the dwell is below 25°, turn both mixture needles counterclockwise an additional turn. If dwell is above 35°, turn both mixture needles clockwise an additional turn. Readjust idle air bleed valve to obtain dwell limits.

After adjustments are complete, seal the idle mixture needle openings in the throttle body, using silicone sealant, RTV rubber, or equivalent. The sealer is required to discourage unnecessary adjustment of the setting, and to prevent fuel vapor loss in that area.

On vehicles WITHOUT a carburetor-mounted Idle Speed Control or Idle Load Compensator, adjust curb idle speed if necessary.

Check, and only if necessary adjust, fast idle speed as described on Emission Control Information label.

**Procedure B (Letter Appears on Idle Air Bleed Valve)**

Carburetors WITH letter identification on the idle air bleed valve are adjusted by:

1. **SETTING THE IDLE AIR BLEED VALVE** to a gage dimension.
  - a. Install air bleed valve gaging tool J-33815-2, BT-8253-B, or equivalent, in throttle side "D" shaped vent hole in the air horn casting. The upper end of the tool should be positioned over the open cavity next to the idle air bleed valve.

*See Figure 6C1-18*

- b. While holding the gaging tool down lightly, so that the solenoid plunger is against the solenoid stop, adjust the idle air bleed valve so that the gaging tool will pivot over and just contact the top of the valve.

*See Figure 6C1-19*

The valve is now set properly. No further adjustment of the valve is necessary.

c. Remove gaging tool.

2. **ADJUSTING THE IDLE MIXTURE NEEDLES** on the vehicle to obtain correct dwell readings.

- a. Remove idle mixture needle plugs, following instructions in **PROCEDURE A**, Number (2), Part d, Steps 1-6 only.
- b. Using Tool J-29030-B, BT-7610-B, or equivalent, turn each idle mixture needle clockwise until lightly seated, then turn each mixture needle counterclockwise 3 turns.
- c. Reinstall carburetor on engine, using a new flange mounting gasket, but do not install air cleaner or gasket at this time.
- d. Start engine and allow it to reach normal operating temperature (drive wheels blocked).
- e. While idling in Drive (Neutral for manual transmission), adjust both mixture needles equally, in 1/8 turn increments, until dwell reading varies within the 25-35° range, attempting to be as close to 30° as possible. If reading is too low, turn mixture needles counterclockwise. If reading is too high, turn mixture needles clockwise. Allow time for dwell reading to stabilize after each adjustment.

After adjustments are complete, seal the idle mixture needle openings in the throttle body, using silicone sealant, RTV rubber, or equivalent. The sealer is required to discourage unnecessary readjustment of the setting, and to prevent fuel vapor loss in that area.

On vehicles WITHOUT a carburetor-mounted Idle Speed Control or Idle Load Compensator, adjust curb idle speed if necessary.

Check, and if necessary, adjust fast idle speed, as described on the Emission Control Information Label.

## UNIT REPAIR

In many cases, necessary service can be carried out and completed without removing the carburetor from the engine. Adjustments of individual systems as found in the preceding "On Vehicle Service" section served as examples.

The information that follows pertains to a complete overhaul. The carburetor first must be removed from the engine. A complete overhaul includes disassembly, thorough cleaning, inspection and replacement of all gaskets, diaphragms, seals, worn or damaged parts, and adjustment of individual systems.

Refer to the exploded view of a typical carburetor for assistance in identification of individual parts, and for disassembly and reassembly of carburetor components.

*See Figure 6C1-21*

**NOTICE:** Before performing any service on the carburetor, it is essential that it be placed on a suitable holding fixture, such as Tool J-9789-118, BT-30-15, or equivalent. Without the use of the holding fixture, it is possible to damage throttle valves or other parts of the carburetor.

## Carburetor Replacement

### Removal

1. Raise hood and cover fenders.
2. Disconnect battery and remove air cleaner.
3. Disconnect accelerator linkage.
4. Disconnect transmission detent cable.
5. Disconnect cruise control, if equipped.
6. Disconnect all necessary vacuum lines.

8. Disconnect fuel line at carburetor inlet.
9. Remove 4 attaching bolts and remove carburetor.

### Installation

1. Reverse removal procedures.
2. Torque remaining bolts to:  
Long Bolts - 9 N·m (7 ft. lbs.)  
Short Bolts - 15 N·m (11 ft. lbs.)

### Idle Control Devices

#### Removal

1. Remove the attaching screws, then remove the Idle Speed Solenoid, Idle Load Compensator or Idle Speed Control from the float bowl.

**NOTICE:** The Idle Speed Solenoid, Idle Load Compensator, or Idle Speed Control, should not be immersed in any carburetor cleaner, and should always be removed before complete carburetor overhaul, as carburetor cleaner will damage the internal components.

2. The Idle Air Bleed Valve is set at the factory and capped with a tamper-resistant riveted cover. The valve assembly should be **REMOVED ONLY** if servicing is required, **OR** when the air horn assembly must be soaked in carburetor cleaner. The valve should be **ADJUSTED** only after servicing, or if the lean mixture screw or the rich mixture stop screw has been adjusted.

**NOTICE:** If the idle air bleed valve is not removed, the air horn assembly should be cleaned with a low volatility cleaning solvent only.

- a. If removal is necessary, cover internal bowl vents and air inlets to the bleed valve with masking tape.

#### See Figure 6C1-23

- b. Carefully align a No. 35 (.110") drill bit on rivet head. Drill only enough to remove head of rivet holding the idle air bleed valve cover.
- c. Use a suitably sized punch to drive out the remainder of the rivet from the castings. Repeat procedure with other rivet.

**CAUTION:** For the next operation, safety glasses must be worn to protect eyes from possible metal shaving damage.

- d. Lift out cover and remove any pieces of rivet still inside tower. Use shop air to blow out any remaining chips.
- e. Remove idle air bleed valve, and check for presence (or absence) of an identifying letter on top of the idle air bleed valve. This will determine the adjustment procedure necessary after reassembly.

#### See Figure 6C1-24

- f. Remove and discard "O" ring seals from valve. New "O" ring seals are required for reassembly. The idle air bleed valve is serviced as a complete assembly only.
3. Remove upper choke lever from the end of choke shaft by removing retaining screw. Rotate upper choke lever to remove choke rod from slot in lever.
4. Remove choke rod from lower lever inside the float bowl casting. Remove rod by holding lower lever

outward with small screwdriver and twisting rod counterclockwise.

5. Remove secondary metering rods by removing the small screw in the top of the metering rod hanger. Lift upward on the metering rod hanger until the secondary metering rods are completely out of the air horn. Metering rods may be disassembled from the hanger by rotating ends out of the holes in the end of the hanger.
6. With a small drift punch of the correct size, drive roll pin (pump lever pivot pin) inward until end of pin is against air cleaner locating boss on air horn casting. Remove pump lever and lever from pump rod.

#### See Figure 6C1-25

**NOTICE:** Use care in removing small roll pin to prevent damage to pump lever casting bosses in air horn.

7. Remove front vacuum break hose from tube on float bowl.
8. Remove eleven air horn-to-bowl screws; then remove the two countersunk attaching screws located next to the venturi. If used, remove secondary air baffle deflector from beneath the two center air horn screws.

#### See Figure 6C1-26

9. Remove air horn from float bowl by lifting it straight up. The air horn gasket should remain on the float bowl for removal later.

**NOTICE:** When removing air horn from float bowl, use care to prevent damaging the mixture control solenoid connector, Throttle Position Sensor (TPS) adjustment lever, and the small tubes protruding from the air horn. These tubes are permanently pressed into the air horn casting. **DO NOT** remove them.

### Air Horn

#### Disassembly

1. Remove front vacuum break bracket attaching screws. The vacuum break assembly may now be removed from the air valve dashpot rod, and the dashpot rod from the air valve lever.

**NOTICE:** Do not place vacuum break assembly in carburetor cleaner, as damage to vacuum break will occur.

2. Remove Throttle Position Sensor (TPS) plunger by pushing plunger up through seal in air horn.

**NOTICE:** To prevent damage to the sealing surface, use fingers only to remove the plunger.

3. Remove TPS seal and pump plunger stem seal by inverting air horn and using a small screwdriver to remove staking holding seal retainers in place. Remove and discard retainers and seals.

#### See Figure 6C1-27

**NOTICE:** Use care in removing the TPS plunger seal retainer and pump plunger stem seal retainer to prevent damage to air horn casting. New seals and retainers are required for reassembly.



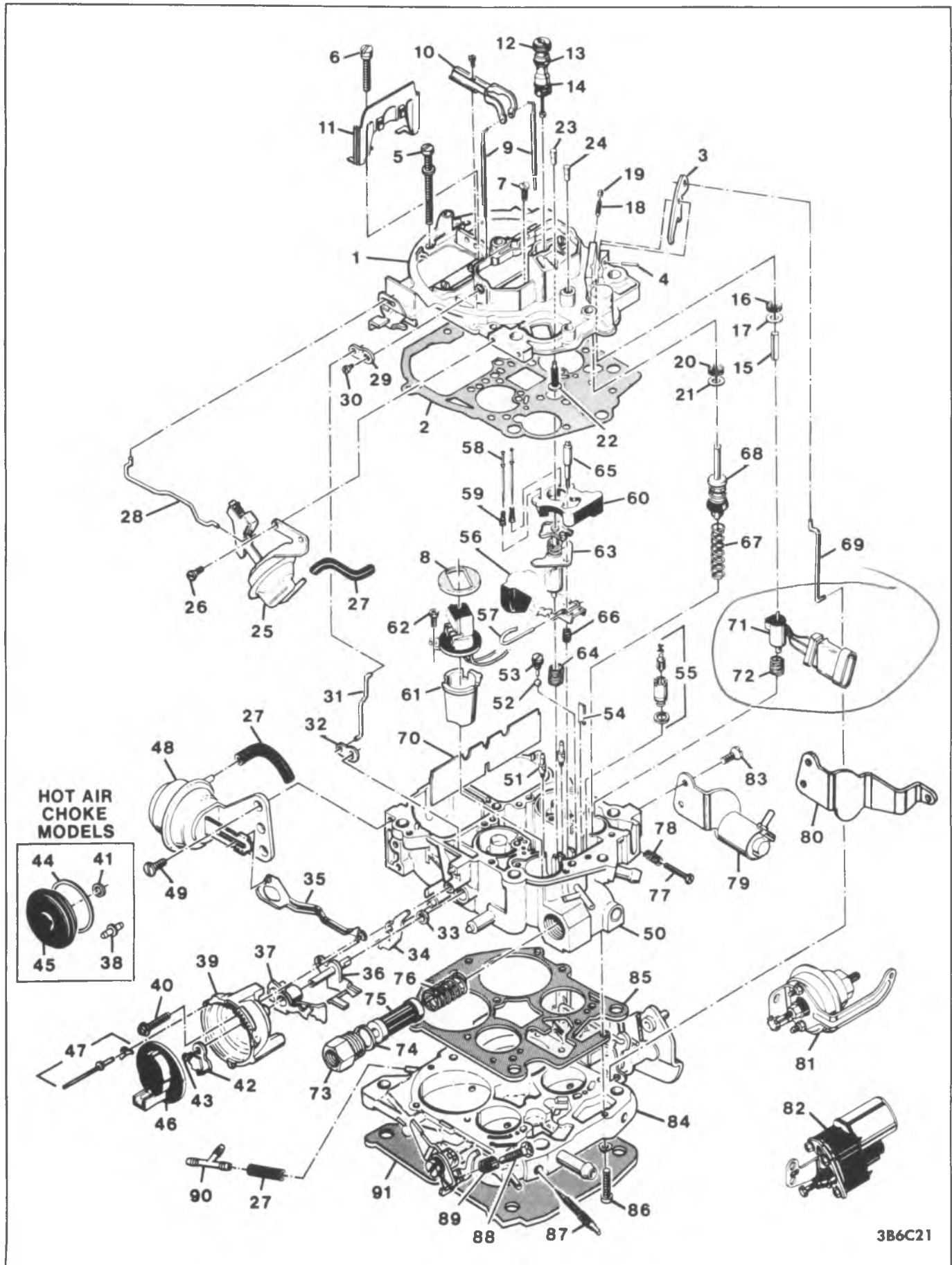

Figure 6C1-21 Carburetor Assembly - Exploded View

## EXPLODED VIEW — MODEL E4ME &amp; E4MC QUADRAJET

## AIR HORN PARTS

1. Air Horn Assembly
2. Gasket — Air Horn
3. Lever — Pump Actuating
4. Roll Pin — Pump Lever Hinge
5. Screw — Air Horn, Long (2)
6. Screw — Air Horn, Short
7. Screw — Air Horn, Countersunk (2)
8. Gasket — Solenoid Connector to Air Horn
9. Metering Rod — Secondary (2)
10. Holder & Screw — Secondary Metering Rod
11. Baffle — Secondary Air
12. Valve — Idle Air Bleed
13. "O" Ring (Thick) — Idle Air Bleed Valve
14. "O" Ring (Thin) — Idle Air Bleed Valve
15. Plunger — TPS Actuator
16. Seal — TPS Plunger
17. Retainer — TPS Seal
18. Screw — TPS Adjusting
19. Plug — TPS Screw
20. Seal — Pump Plunger
21. Retainer — Pump Seal
22. Screw — Solenoid Plunger Stop (Rich Mixture Stop)
23. Plug — Plunger Stop Screw (Rich Mixture Stop)
24. Plug — Solenoid Adjusting Screw (Lean Mixture)

## CHOKE PARTS

25. Vacuum Break & Bracket — Front
26. Screw — Vacuum Break Attaching (2)
27. Hose — Vacuum
28. Rod — Air Valve
29. Lever — Choke Rod (Upper)
30. Screw — Choke Lever
31. Rod — Choke
32. Lever — Choke Rod (Lower)
33. Seal — Intermediate Choke Shaft
34. Lever — Secondary Lockout
35. Link — Rear Vacuum Break
36. Intermediate Choke Shaft & Lever
37. Cam — Fast Idle
38. Seal — Choke Housing to Bowl (Hot Air Choke)
39. Choke Housing
40. Screw — Choke Housing to Bowl
41. Seal — Intermediate Choke Shaft (Hot Air Choke)
42. Lever — Choke Coil
43. Screw — Choke Coil Lever
44. Gasket — Stat Cover (Hot Air Choke)
45. Stat Cover & Coil Assembly (Hot Air Choke)
46. Stat Cover & Coil Assembly (Electric Choke)
47. Kit — Stat Cover Attaching
48. Vacuum Break Assembly — Rear
49. Screw — Vacuum Break Attaching (2)

## FLOAT BOWL PARTS

50. Float Bowl Assembly
51. Jet — Primary Metering (2)
52. Ball — Pump Discharge
53. Retainer — Pump Discharge Ball
54. Baffle — Pump Well
55. Needle & Seat Assembly
56. Float Assembly
57. Hinge Pin — Float Assembly
58. Rod — Primary Metering (2)
59. Spring — Primary Metering Rod (2)
60. Insert — Float Bowl
61. Insert — Bowl Cavity
62. Screw — Connector Attaching
63. Mixture Control (M/C) Solenoid & Plunger Assembly
64. Spring — Solenoid Tension
65. Screw — Solenoid Adjusting (Lean Mixture)
66. Spring — Solenoid Adjusting Screw
67. Spring — Pump Return
68. Pump Assembly
69. Link — Pump
70. Baffle — Secondary Bore
71. Throttle Position Sensor (TPS)
72. Spring — TPS Tension
73. Filter Nut — Fuel Inlet
74. Gasket — Filter Nut
75. Filter — Fuel Inlet
76. Spring — Fuel Filter
77. Screw — Idle Stop
78. Spring — Idle Stop Screw
79. Idle Speed Solenoid & Bracket Assembly
80. Bracket — Throttle Return Spring
81. Idle Load Compensator & Bracket Assembly
82. Idle Speed Control & Bracket Assembly
83. Screw — Bracket Attaching

## THROTTLE BODY PARTS

84. Throttle Body Assembly
85. Gasket — Throttle Body
86. Screw — Throttle Body
87. Idle Needle & Spring Assembly (2)
88. Screw — Fast Idle Adjusting
89. Spring — Fast Idle Screw
90. Tee — Vacuum Hose
91. Gasket — Flange

3B6C60

Figure 6C1-22 Exploded View Parts Description



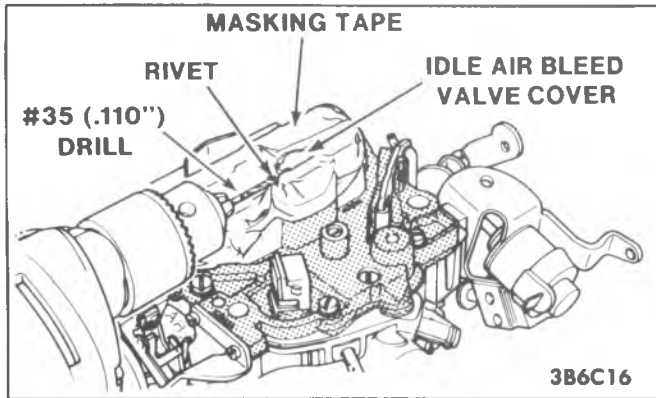

Figure 6C1-23 Removing Idle Air Bleed Valve Rivets

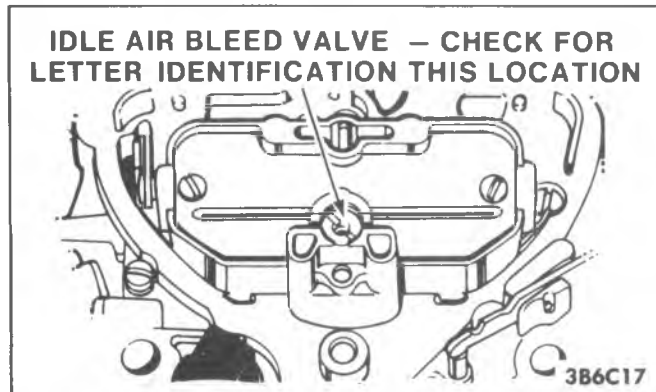

Figure 6C1-24 Idle Air Bleed Valve-ID Letter Location

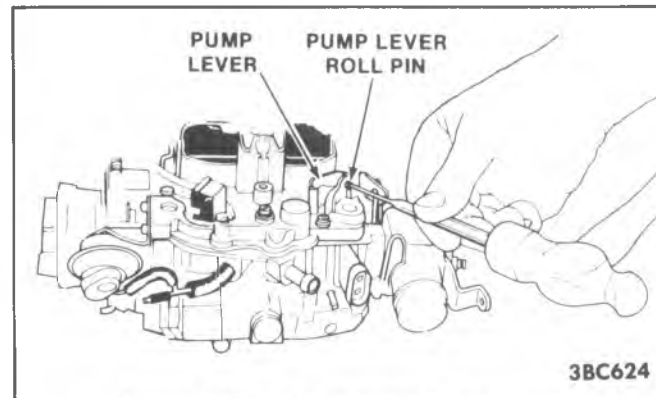

Figure 6C1-25 Removing Pump Lever

4. Invert air horn, and use Tool J-28696-4, BT-7967A, or equivalent, to remove rich mixture stop screw.

See Figure 6C1-27

5. Use a suitable punch to drive Lean Mixture Screw Plug and Rich Mixture Stop Screw Plug out of the air horn. Discard plugs.

See Figure 6C1-28

Further disassembly of the air horn is not required for cleaning purposes.

The choke valve and choke valve screws, the air valves and air valve shaft should not be removed. However, if it is necessary to replace the air valve closing spring or center plastic eccentric cam, a repair kit is available. Instructions for assembly are included in the repair kit.

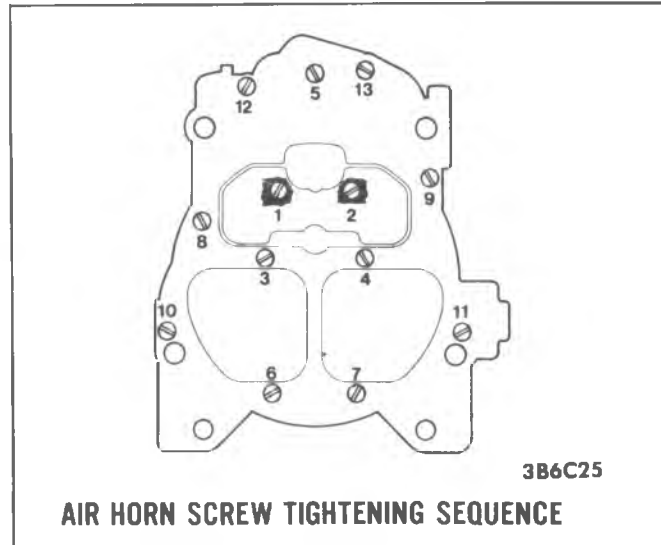

Figure 6C1-26 Air Horn Screw Location

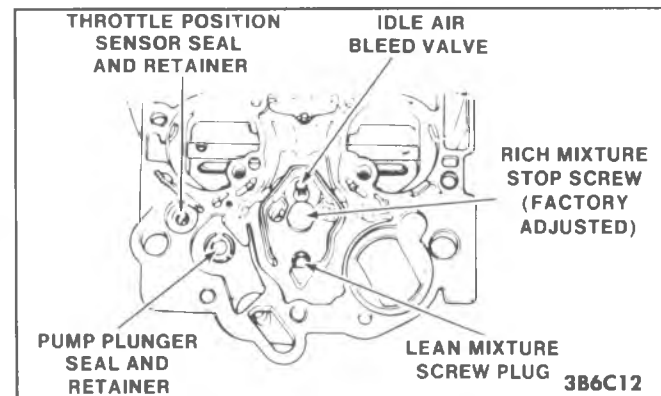

Figure 6C1-27 Pump Plunger and TPS Seal Removal

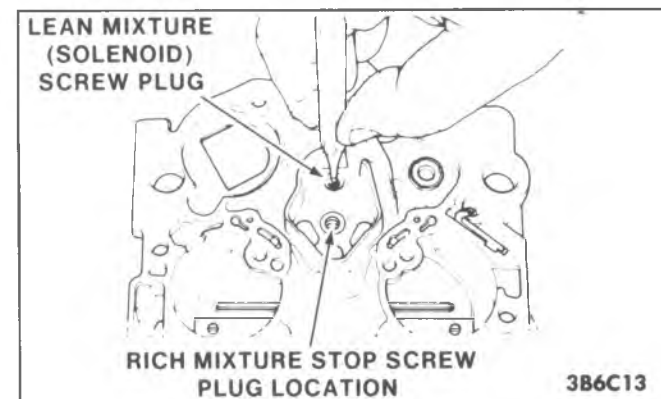

Fig. 6C1-28 Removing Lean Mix. Screw & Rich Mix. Stop Screw Plugs

## Float Bowl

### Disassembly

1. Remove solenoid-metering rod plunger by lifting straight up.

See Figure 6C1-29

2. Remove air horn gasket by lifting it from the dowel locating pins on float bowl. Discard gasket.
3. Remove pump plunger from pump well.
4. Remove pump return spring from pump well.
5. Remove staking holding Throttle Position Sensor (TPS) in bowl as follows:

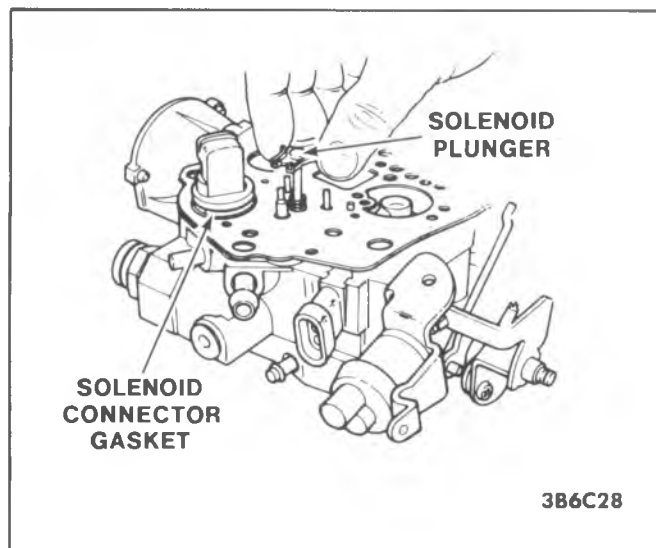

Figure 6C1-29 Solenoid Plunger Removal

- a. Lay a flat tool or metal piece across bowl casting to protect gasket sealing surface.
- b. Use a small screwdriver to depress TPS sensor lightly and hold against spring tension.
- c. Observing safety precautions, pry upward with a small chisel or equivalent to remove bowl staking, making sure prying force is exerted against the metal piece and not against the bowl casting.

**NOTICE:** Use care not to damage the TPS sensor.

- d. Push up from bottom on electrical connector and remove TPS and connector assembly from bowl.

**NOTICE:** Use care in removing sensor and connector assembly to prevent damage to this critical electrical part.

Remove spring from bottom of TPS well in float bowl.

6. Remove plastic filler block over float bowl.
7. Carefully lift each metering rod out of the guided metering jet, checking to be sure the return spring is removed with each metering rod. Remove return spring by sliding off end of rod.

See Figure 6C1-30

**NOTICE:** Use extreme care when handling these critical parts to avoid damage to metering rod and spring.

8. Remove the mixture control solenoid from the float bowl as follows:
  - a. Remove screw attaching solenoid connector to float bowl. Do not remove solenoid connector from float bowl until called for in text.
  - b. Use Tool J-28696-10, BT-7928, or equivalent, to remove lean mixture (solenoid) screw. Do not remove plunger return spring or connector and wires from the solenoid body. The mixture control solenoid with plunger, and connector are only serviced as a complete assembly.
  - c. If used, remove plastic aneroid cavity insert from cavity in float bowl beneath solenoid connector.
  - d. Remove solenoid screw tension spring (next to float hanger pin).

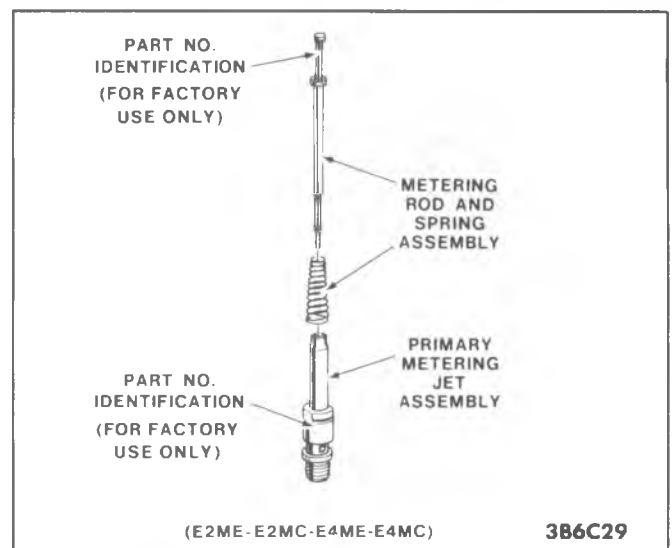

Figure 6C1-30 Metering Rod and Jet Identification

9. Remove float assembly and float needle by pulling up on retaining pin. Remove needle and seat and gasket using set remover Tool J-22769, BT-3006M, or equivalent.
10. Remove large mixture control solenoid tension spring from boss on bottom of float bowl located between guided metering jets.
11. If necessary, remove the primary main metering jets using special Tool J-28696-4, BT-7928, or equivalent.

**NOTICE:** Use care installing tool on jet, to prevent damage to the metering rod guide (upper area), and locating tool over vertical flat sections on lower area of jet. Also, no attempt should be made to remove the secondary metering jets (metering orifice plates). These jets are fixed and, if damaged, entire bowl replacement is required.

12. Remove pump discharge check ball retainer and turn bowl upside down, catching discharge ball in palm of hand.
13. Remove secondary air baffle, if replacement is required.
14. Remove pump well fill slot baffle only if necessary.
15. If rear vacuum break assembly is used, remove hose from assembly, and remove rear vacuum break control and bracket assembly. Also, remove two screws from bracket and rotate the assembly to remove vacuum break rod from slot in plunger head. The non-adjustable vacuum break rod, riveted to the intermediate choke lever, is not removed at this time, but is removed after the removal of the choke assembly from the float bowl.

**NOTICE:** Do not place vacuum break assembly in carburetor cleaner, as damage to unit will occur.

## Choke

### Disassembly

The tamper-resistant choke cover is used to discourage unnecessary readjustment of the choke thermostatic cover an coil assembly. However, if it is necessary to remove the cover and coil assembly during normal carburetor disassembly for cleaning and overhaul, the procedures below should be followed.

## Choke Cover

### Removal

1. Support float bowl and throttle body, as an assembly, on a suitable holding fixture such as Tool J-9789-118, BT-30-15, or equivalent.
2. Carefully align a #21 drill (.159") on rivet head and drill only enough to remove rivet head.

See Figure 6C1-31

Drill the two remaining rivet heads, then use a drift and small hammer to drive the remainder of the rivets out of the choke housing.

**NOTICE:** Use care in drilling to prevent damage to the choke cover or housing.

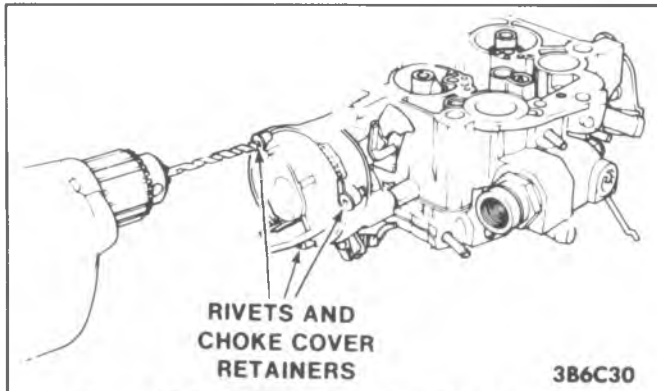

Figure 6C1-31 Choke Housing Rivet Removal

3. Remove the two conventional retainers, retainer with tab, choke cover gasket (where used), and choke cover assembly from choke housing. Do not remove baffle plate from beneath the thermostatic coil on the choke cover (hot air choke models).
4. Remove choke housing assembly from float bowl by removing retaining screw and washer inside the choke housing. The complete choke assembly can be removed from the float bowl by sliding outward.

See Figure 6C1-32

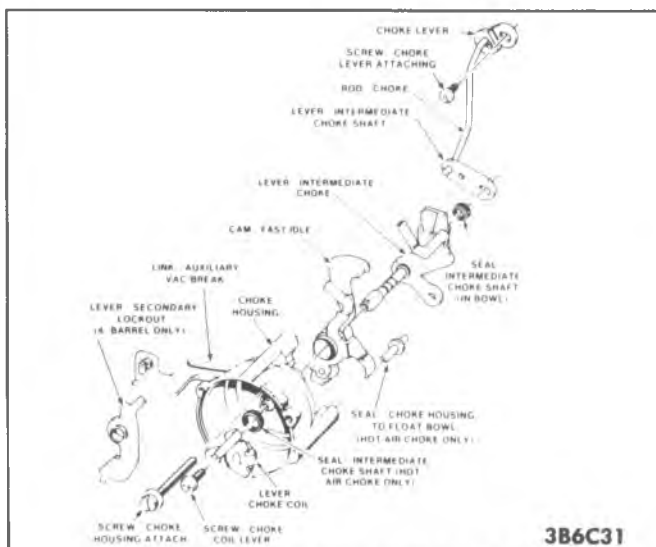

Figure 6C1-32 Choke Assembly Removal

5. Remove plastic tube seal (hot air models only) from vacuum inlet boss on choke housing.

**NOTICE:** Do not immerse the plastic tube seal in carburetor cleaner, as damage to seal will occur.

6. Remove secondary throttle valve lock-out lever from float bowl.

See Figure 6C1-32

7. Remove lower choke lever from inside float bowl cavity by inverting bowl.
8. To disassemble intermediate choke shaft from choke housing, remove coil lever retaining screw at end of shaft inside the choke housing. Remove thermostatic coil lever from flats on intermediate choke shaft. Remove intermediate choke shaft from the choke housing by sliding it outward. The fast idle cam can now be removed from the intermediate choke shaft.

**NOTICE:** On hot air choke models, remove the cup seal from inside the choke housing shaft hole. Discard the seal. Also, remove the cup seal from the float bowl insert for bowl cleaning purposes. **DO NOT ATTEMPT TO REMOVE THE INSERT.**

## Remaining Float Bowl Parts

### Disassembly

1. Remove fuel inlet nut, gasket, check valve, filter assembly and spring. Discard check valve filter assembly and gasket.
2. Remove three throttle body-to-bowl attaching screws and lockwashers and remove throttle body assembly.
3. Remove throttle body-to-bowl insulator gasket.

## Throttle Body

### Disassembly

**NOTICE:** Place throttle body assembly on carburetor holding fixture to avoid damage to throttle valves.

1. Remove pump rod from throttle lever by rotating rod until tang on rod aligns with slot in lever.

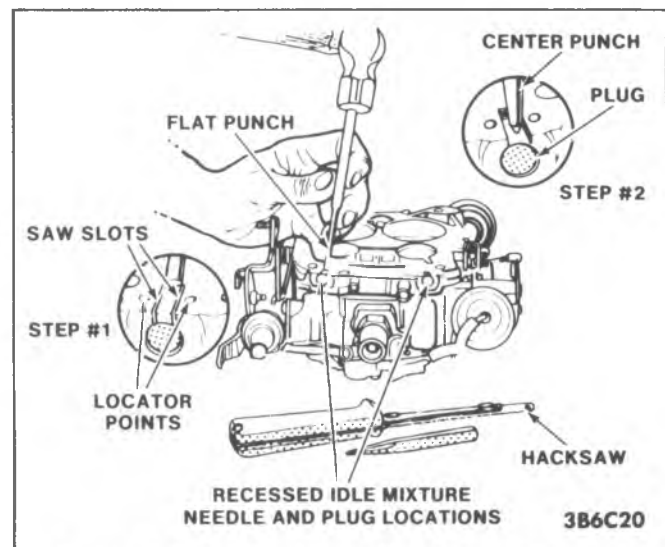

Figure 6C1-33 Idle Mixture Needle Plug Removal

2. Remove Idle Mixture Needle Plugs:

- a. With manifold side up, use hacksaw to make two parallel cuts in the throttle body, one on each side of the locator points beneath the idle mixture needle plug.

### See Figure 6C1-33

The cuts should reach down to the steel plug, but should not extend more than 1/8" beyond the locator points. The distance between the saw cuts will depend on the size of the punch to be used.

- b. Place a flat punch at a point near the ends of the saw marks in the throttle body. Hold the punch at a 45° angle, and drive it into the throttle body until the casting breaks away, exposing the steel plug.

The hardened steel plug will break rather than remaining intact. It is not necessary to remove the plug in one piece, just remove the loose pieces.

- c. Repeat the procedure for the other idle mixture needle plug.

3. Use Tool J-29030-B, BT-7610B, or equivalent, to remove idle mixture needles, for thorough throttle body cleaning.

Further disassembly of the throttle body is not required for cleaning purposes. The throttle valve screws are permanently staked in place and should not be removed. The throttle body is serviced as a complete assembly.

## Cleaning and Inspection

Except for the air horn assembly with idle air bleed valve installed, the carburetor parts should be cleaned in a cold immersion type cleaner such as Carbon X (X-55) or its equivalent. The air horn assembly, with idle air bleed in place, should be cleaned using only a low volatility cleaning solvent.

**NOTICE:** The air horn (with bleed valve), idle speed solenoid, idle load compensator, idle speed control, throttle position sensor, thermostatic choke cover and coil, rubber parts, plastic parts, diaphragms, pump plunger, etc., should not be immersed in carburetor cleaner as they will swell, harden, or distort. Also, provide special protection for the metering rods and jets, and idle air bleed valve (if removed) when cleaning to prevent damage to these critical parts.

The plastic cam on the air valve shaft and bushing in bowl will withstand normal cleaning. Rinse thoroughly after cleaning.

1. Thoroughly clean all metal parts and blow dry with compressed air. Make sure all fuel passages and metering parts are free of burrs and dirt. Do not pass drills or wire through jets.
2. Inspect upper and lower surfaces of carburetor castings for damage.
3. Inspect holes in levers for excessive wear or out-of-round conditions. If worn, levers should be replaced.
4. Inspect plastic parts for cracks, damage, etc. Replace if necessary.
5. Check, repair or replace parts if the following problems are encountered:
  - a. **FLOODING**
    1. Inspect float needle and seat for dirt, deep wear grooves, scores and proper seating.

2. Inspect float needle pull clip for proper installation. Be careful not to bend needle pull clip.

### See Figure 6C1-34

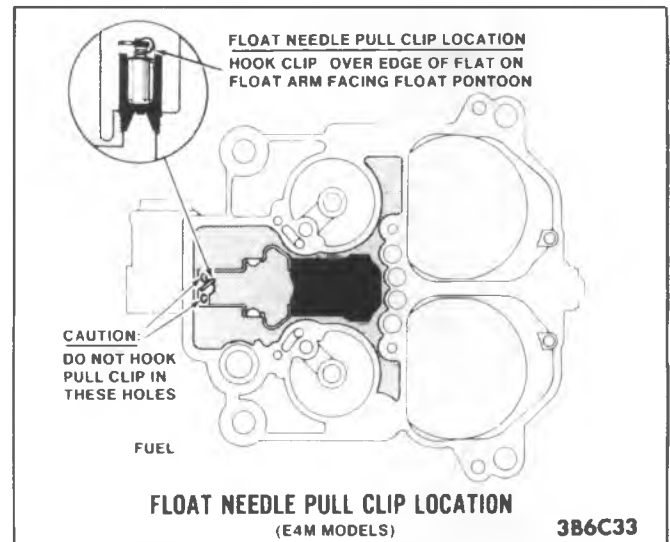

Figure 6C1-34 Float Needle Pull Clip Location

3. Inspect float, float arms and hinge pin for distortion, binds and burrs. Check weight of the float in comparison with a new float.
  4. Replace fuel inlet filter and check valve.
- b. **HESITATION**
    1. Inspect pump plunger for cracks, scores or excessive cup wear, and replace plunger if necessary.
    2. Inspect pump duration and return springs for distortion.
    3. Check all pump passages and jets for dirt, improper seating of discharge check ball and scores in pump well. Check condition of pump discharge check ball.
    4. Check pump linkage for excessive wear. Repair or replace if necessary.
  - c. **HARD STARTING-POOR COLD OPERATION**
    1. Check choke valve and linkage for excessive wear, binds or distortion.
    2. Inspect choke vacuum break diaphragms for leaks.
    3. Replace carburetor fuel filter.
    4. Inspect float needle for sticking, dirt, etc.
    5. Examine fast idle cam for wear or damage.
    6. Also check items under "Flooding".
  - d. **POOR PERFORMANCE - POOR GAS MILEAGE**
    1. Clean all fuel and vacuum passages in castings.
    2. Check choke valve for freedom of movement.
    3. Check metering rods for dirt, sticking, binding, missing springs, damage parts or excessive wear.
    4. Check mixture control solenoid plunger for sticking, binding, damaged parts or excessive wear.
    5. Inspect metering jets for being dirty, loose, worn or damaged. Numbers stamped on

primary metering rods and jets are for internal factory identification only, and DO NOT indicate the rod or jet size. Service replacement rods and jets are included in a Metering Jet and Rod service package, and must be installed in matched sets.

6. Check idle air bleed valve for sticking, binding, dirt, damage or missing "O" rings.
7. Check air valve for binds and damage. If air valve is damaged, the air horn assembly must be replaced. A torsion spring kit is available for repairs to air valve closing spring. A new plastic secondary metering rod cam is included in the kit.
8. Check TPS plunger for sticking, binding, or improper adjustment. Plunger must move freely in seal in air horn.

#### e. ROUGH IDLE

1. Inspect gasket and gasket mating surfaces on castings for damage to sealing beads, nicks, burrs and other damage.
2. Clean all idle fuel passages.
3. If removed, inspect idle mixture needles for ridges, burrs, or being bent.
4. Check idle air bleed valve for sticking, binding, dirt or missing "O" rings.
5. Check throttle lever and valves for binds, nicks, and other damage.
6. Check all diaphragms for possible ruptures or leaks.
7. Clean plastic parts only in cleaning solvent - never in gasoline.

**NOTICE:** Choke linkage and fast idle cam must operate freely. Bent, dirty or otherwise damaged linkage must be cleaned, repaired, or replaced as necessary. Do not lubricate linkage, as this will collect dust and cause sticking.

### Check Fuel Lines and Service Fuel Filter

1. Inspect fuel lines for kinks, bends, or leaks and correct any problems found.
2. Replace filter in carburetor inlet, making sure the type used includes the check valve in the filter inlet.

If a complaint of poor high speed performance exists on the car, fuel pump filter and lines should be checked.

### Throttle Body

#### Assembly

1. Install lower end of pump rod in throttle lever by aligning tang on rod with slot in lever. End of rod should point outward toward throttle lever.
2. Install idle mixture needles and springs using Tool J-29030-B, BT-7610B, or equivalent. Lightly seat each needle and then turn counterclockwise the number of turns shown in the Specifications chart at the end of this Carburetor section.

Final idle mixture adjustment is made on the vehicle. (See Mixture Control Adjustments under "On Vehicle Service").

### Float Bowl

#### Assembly

If a new float bowl assembly is used, stamp or engrave the model number on the new float bowl at location shown in Figure 6C1-1.

1. Install new throttle body-to-bowl insulator gasket over two locating dowels on bowl.
2. Install throttle body making certain throttle body is properly located over dowels on float bowl. Install three throttle body-to-bowl screws and lockwashers and tighten evenly and securely.
3. Place carburetor on proper holding fixture such as J-9789-118, BT-30-15, or equivalent.
4. Install fuel inlet filter spring, a new check valve filter assembly, new gasket and inlet nut. Tighten nut to 24 N·m (18 ft. lbs.).

**NOTICE:** When installing a service replacement filter, make sure the filter is the type that includes the check valve to meet government safety standards. New service replacement filters with check valve meet this requirement. When properly installed, hole in filter faces toward inlet nut. Ribs on closed end of filter element prevent filter from being installed incorrectly unless forced. Tightening beyond specified torque can damage nylon gasket.

### Choke Housing to Float Bowl

#### Assembly

1. Install new cup seal into insert on side of float bowl for intermediate choke shaft. Lip on cup seal faces outward.
2. Install secondary throttle valve lock-out lever on boss of float bowl, with recess in hole in lever facing inward.

#### See Figure 6C1-32

3. Install new cup seal in inside choke housing shaft hole. Lip on seal faces inward, toward inside of housing.
4. Install fast idle cam on the intermediate choke shaft (steps on cam face downward).
5. Carefully install fast idle cam and intermediate choke shaft assembly in choke housing. Install thermostatic coil lever on flats on intermediate choke shaft. Inside thermostatic choke coil lever is properly aligned when both inside and outside levers face toward fuel inlet. Install inside lever retaining screw into end of intermediate choke shaft. Tighten securely.
6. If used, install rear vacuum break unit in hole of the intermediate choke shaft lever. The end of the link faces toward the choke housing when installed correctly.
7. On hot air choke models, insert plastic tube seal (to float bowl) in vacuum inlet hole on choke housing.
8. Install lower choke rod (inner) lever into cavity in float bowl.

#### See Figure 6C1-34

Install choke housing to bowl, sliding intermediate choke shaft into lower (inner) lever, (Figure 6C1-32). Tool J-23417, BT-6911, or equivalent, can be used to hold the lower choke lever in correct position while installing the choke housing.

The intermediate choke shaft lever and fast idle cam are in correct position when the tang on lever is beneath the fast idle cam.

9. Install choke housing retaining screws and washers, and tighten securely.

#### See Figure 6C1-32

Check linkage for freedom of movement. Do not install choke cover and coil assembly until inside coil lever is adjusted, (see Adjustment Procedures and Specifications at end of this section).

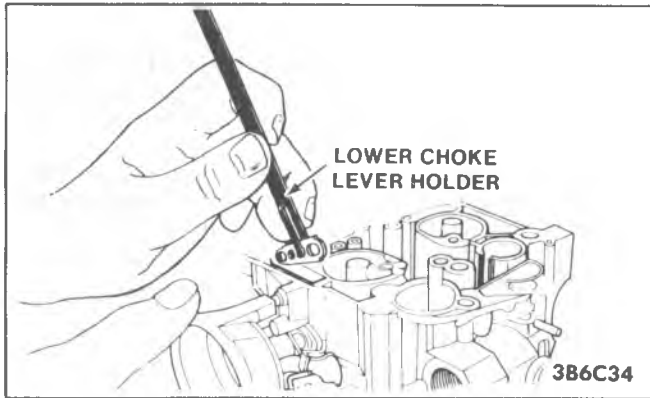

Figure 6C1-35 Installing Lower Choke Lever

### Completion of Float Bowl Assembly

1. If used, install end of vacuum break rod in slot in rear vacuum break plunger. Install rear vacuum break and bracket assembly on float bowl, using two large countersunk attaching screws. Tighten securely.
2. If removed, install air baffle in secondary side of float bowl with notches toward the top. Top edge of baffle must be flush with bowl casting.
3. If removed, install baffle inside of pump well with slot toward bottom.
4. Install pump discharge check ball, and retainer screw, in passage next to pump well. Tighten retainer screw securely.
5. If removed, carefully install primary main metering jets in bottom of float bowl using Tool J-28696-4, BT-7928, or equivalent.

**NOTICE:** Use care in installing jets to prevent damage to metering rod guide.

6. Install large mixture control solenoid tension spring over boss on bottom of float bowl.
7. Install needle seat assembly, with gasket, using seat installer J-22769, BT-3006M, or equivalent.
8. To make adjustment easier, carefully bend float arm upward at notch in arm before assembly.
9. Install float needle onto float arm by sliding float lever under needle pull clip. Proper installation of the needle pull clip is to hook the clip over the edge of the float on the float arm facing the float pontoon.

See Figure 6C1-34

10. Install float hinge pin into float arm with end of loop of pin facing pump well. Install float assembly by aligning needle in the seat, and float hinge pin into locating channels in float bowl. **DO NOT** install float needle pull clip into holes in float arm.
11. Make Float Level Adjustment. Procedure will be found in Carburetor Adjustment Procedures section.

See Figure 6C1-33

12. If used, install plastic aneroid cavity insert beneath the mixture control solenoid connector in float bowl, aligning insert with the recess of bowl cavity. Tang on upper lip of insert goes in deep slot in bowl closest to the fuel inlet nut. Make sure insert is seated in cavity and flush with float bowl casting surface.
13. Install mixture control solenoid screw tension spring between raised bosses next to float hanger pin.
14. Install mixture control solenoid and connector assembly as follows:

- a. Install solenoid carefully in the float chamber, aligning pin on end of solenoid with hole in raised boss at bottom of bowl. Align solenoid connector wires to fit in slot in bowl, or plastic insert if used.
- b. Install lean mixture (solenoid) screw through hole in solenoid bracket and tension spring in bowl, engaging first six screw threads to assure proper thread engagement.
- c. Install mixture control solenoid gaging Tool J-33815-1, BT-8253-A, or equivalent, over the throttle side metering jet rod guide, and temporarily install solenoid plunger.

See Figure 6C1-36

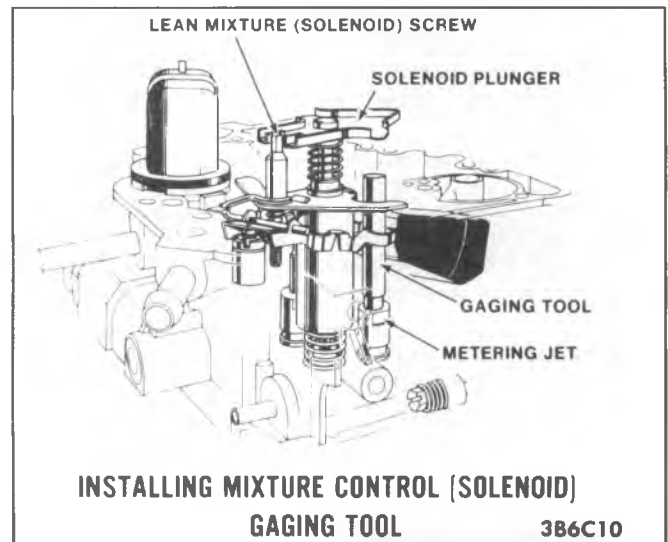

Figure 6C1-36 Installing Mix. Control Solenoid Gaging Tool

- d. Holding the solenoid plunger against the Solenoid Stop, use Tool J-28696-10, BT-7928, or equivalent, to turn the lean mixture (solenoid) screw slowly clockwise, until the solenoid plunger just contacts the gaging tool. The adjustment is correct when the solenoid plunger is contacting **BOTH** the Solenoid Stop and the Gaging Tool.

See Figure 6C1-37

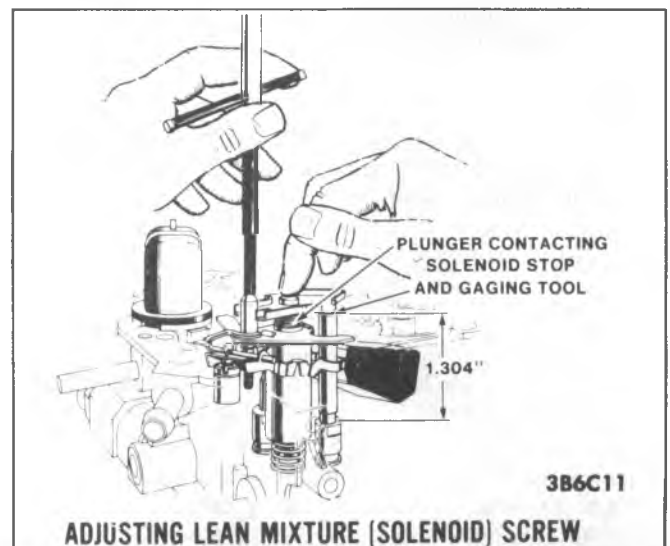

Figure 6C1-37 Adjusting Lean Mixture (Solenoid) Screw

e. Remove solenoid plunger and gaging tool.

15. Align solenoid wires with notch in plastic insert (if used) and connector lugs with recesses in bowl. Install connector attaching screw. Tighten screw securely.

**NOTICE:** DO NOT overtighten screw, which could cause damage to the connector.

16. Install Throttle Position Sensor return spring in bottom of well in float bowl.
17. Install Throttle Position Sensor and connector assembly in float bowl by aligning groove in electrical connector with slot in float bowl casting. Push down on connector and sensor assembly so that connector and wires are located below bowl casting surface.
18. Install plastic filler block over float valve, pressing downward until properly seated (flush with bowl casting surface).
19. Slide metering rod return spring over metering rod tip until small end of spring stops against shoulder on rod. Carefully install metering rod and spring assembly through hole in plastic filler block and gently lower the metering rod into the guided metering jet, until large end of spring seats on the recess on end of jet guide.

**NOTICE:** DO NOT FORCE METERING ROD down in jet. USE EXTREME CARE when handling these critical parts to avoid damage to rod and spring. If service replacement metering rods, springs and jets are installed, they must be installed in matched sets.

20. Install pump return spring in pump well.
21. Install pump plunger assembly in pump well.
22. Holding down on pump plunger assembly against return spring tension, install air horn gasket by aligning pump plunger stem with hole in gasket, and aligning holes in gasket over TPS plunger, solenoid plunger return spring, metering rods, solenoid attaching screw and electrical connector. Position gasket over the two dowel locating pins on the float bowl.
23. Holding down on air horn gasket and pump plunger assembly, install the solenoid-metering rod plunger in the solenoid, aligning slot in end of plunger with solenoid attaching screw. Be sure plunger arms engage top of each metering rod.

#### See Figure 6C1-29

If a service replacement Mixture Control Solenoid package is installed, the solenoid and plunger **MUST** be installed as a matched set.

## Air Horn

### Assembly

1. If removed, install TPS adjustment screw in air horn using Tool J-28696-10, BT-7967A, or equivalent. Final adjustment of the Throttle Position Sensor is made on vehicle (see "On Vehicle Service").
2. Inspect the air valve shaft pin for lubrication. Apply a liberal quantity of lithium base grease to the air valve shaft pin, especially in the area contacted by the air valve spring.
3. Install new pump plunger stem seal and retainer in air horn casting.

#### See Figure 6C1-27

The lip on the seal faces outward, away from the air horn mounting surface. Lightly stake seal retainer in three places, choosing locations different from the original stakings.

4. Install rich mixture stop screw from bottom side of the air horn. Use Tool J-28696-4, BT-7967A, or equivalent, to bottom the stop screw lightly, then back out 1/4 turn. Final adjustment procedure will be covered later in this section.

## Air Horn to Bowl

### Installation

1. Carefully lower air horn assembly onto float bowl while positioning the TPS Adjustment Lever over the TPS sensor, and guiding pump plunger stem through seal in air horn casting. To ease installation, insert a thin screwdriver between air horn gasket and float bowl to raise the TPS Adjustment Lever positioning it over the TPS sensor.

#### See Figure 6C1-38

Make sure that the bleed tubes and accelerating well tubes are positioned properly through the holes in the air horn gasket. Do not force the air horn assembly onto the bowl, but lower it lightly into place.

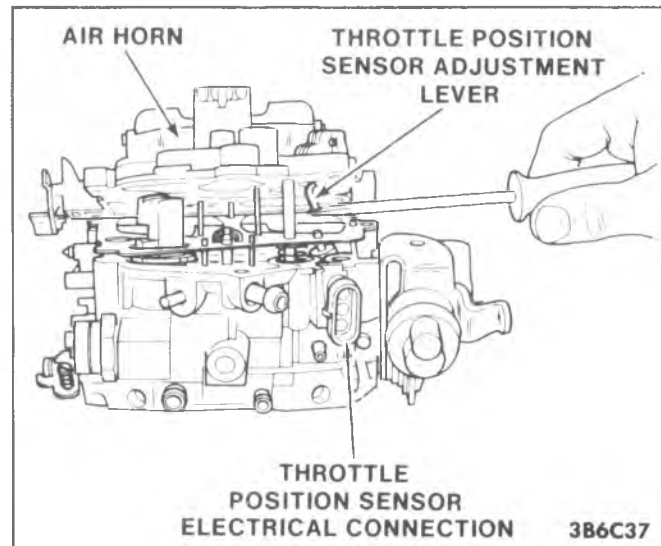

Figure 6C1-38 Installing Air Horn

2. Install two long air horn screws and lockwashers, nine short screws and lockwashers, and two countersunk screws (located next to the carburetor venturi area). Install secondary air baffle beneath screws No. 3 and 4.

#### See Figure 6C1-24

Tighten all screws evenly and securely, following air horn screw tightening sequence.

#### See Figure 6C1-26

3. Install air valve rod into slot in the lever on the end of the air valve shaft. Install the other end of the rod in hole in front vacuum break plunger. Install front vacuum break and bracket assembly on the air horn, using two attaching screws. Tighten screws securely. If vacuum break adjustment is necessary, see Adjustment Procedures and Specifications.



4. Install TPS actuator plunger in air horn, by carefully pushing plunger through seal in air horn until seated against TPS plunger. Check plunger for freedom of movement.
5. Connect upper end of pump rod to pump lever. Place lever between raised bosses on air horn casting, making sure lever engages TPS actuator plunger and the pump plunger stem. Align hole in pump lever with holes in air horn casting boxes. Using a small drift or rod the diameter of the pump lever roll pin will aid alignment. Using diagonal (sidecutter) pliers on the end of the roll pin, pry the roll pin only enough to insert a thin blades screwdriver between the end of the pump lever roll pin and the air cleaner locating boss on air horn casting. Use screwdriver to push pump lever roll pin back through the casting until end of pin is flush with casting bosses on the air horn.

**NOTICE:** Use care installing the roll pin to prevent damage to the pump lever bearing surface and casting bosses.

6. Install two secondary metering rods into the secondary metering rod hanger (upper end of rods point toward each other). Install secondary metering rod holder, with rods, onto air valve cam follower. Install retaining screw and tighten securely. Work air valves up and down several times to make sure they move freely in both directions.
7. Connect choke rod into lower choke lever inside bowl cavity. Install choke rod in slot in upper choke lever, and position lever on end of choke shaft, making sure flats on end of shaft align with flats in lever. Install attaching screw and tighten securely. When properly installed, the lever will point to the rear of the carburetor, and the number on the lever will face outward.
8. Adjust the Rich Mixture Stop Screw:
  - a. Insert external float gaging Tool J-9789-130, BT-7720, or equivalent, in the vertical "D" shaped vent hole in the air horn casting, (next to the Idle Air Bleed Valve), and allow it to float freely.

See Figure 6C1-39

It may be necessary to modify the gage, by filing it, to permit it to enter the hole freely.

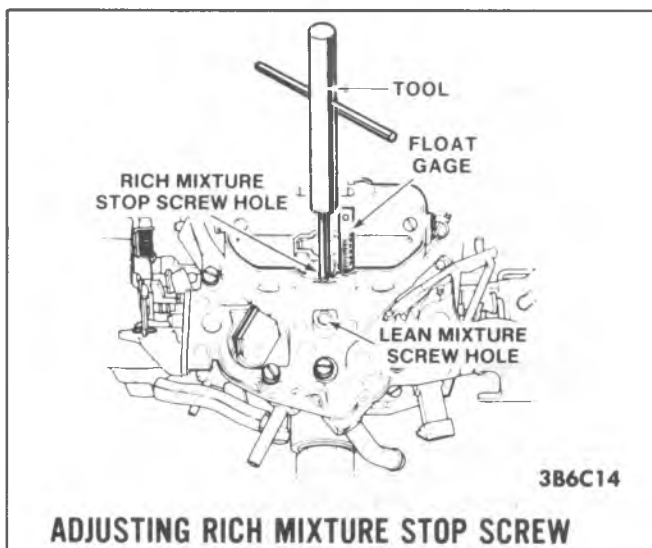

Figure 6C1-39 Adjusting Rich Mixture Stop Screw

- b. Read at eye level the mark on the gage, in inches, that lines up with the top of the air horn casting. Record reading.
  - c. Lightly press down on gage, and again read and record the mark on the gage that lines up with the top of the air horn casting.
  - d. Subtract gage UP dimension, found in Step b, from gage DOWN dimension, found in Step c, and record the difference in inches. This difference in dimensions is total solenoid plunger travel.
  - e. Insert Tool J-28696-10, BT-7928, or equivalent, in the access hole in the air horn, and adjust the rich mixture stop screw to obtain 4/32" total solenoid plunger travel.
9. With solenoid plunger travel correctly set, install plugs, supplied in service kit, in the air horn:
  - a. Install plug, hollow end down, into the access hole to the lean mixture (solenoid) screw, and use a suitably sized punch to drive plug into the air horn until top of plug is even with the lower edge of the hole chamfer.

See Figure 6C1-40

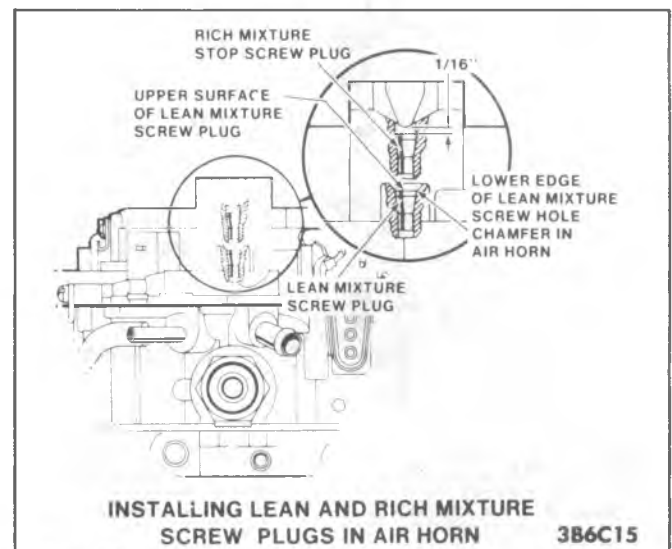

Fig. 6C1-40 Installing Plugs (Lean & Rich Mix. Stop Screws)

Plug must be installed to retain the setting of the screw, and to prevent fuel vapor loss.

- b. In a similar manner, install plug over the rich mixture stop screw access hole, and drive plug into place so that the top of the plug is 1/16" below the surface of the air horn casting. Plug must be installed to retain the setting of the screw.

See Figure 6C1-40

10. Install the Idle Air Bleed Valve:

- a. Lightly coat two new "O" ring seals with silicone oil, or automatic transmission fluid, to aid in their installation on the idle air bleed valve body. The thick seal goes in the upper groove, and the thin seal goes in the lower groove.

See Figure 6C1-41

- b. Install idle air bleed valve in the air horn, making sure that there is proper thread engagement.
  - c. Insert idle air bleed valve gaging Tool J-33815-2, BT-8353-B, or equivalent, in throttle side "D" shaped vent hole of the air horn casting. The upper



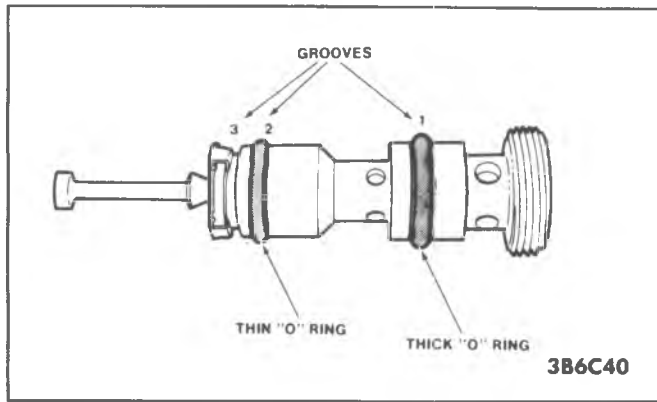
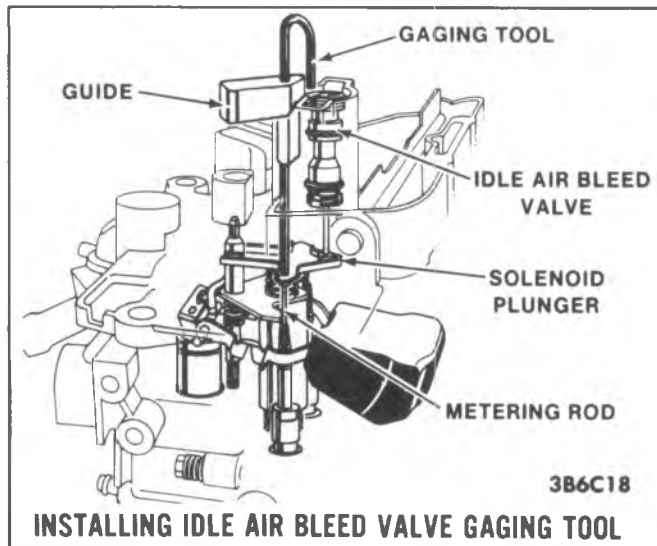

Figure 6C1-41 Idle Air Bleed Valve Assembly

end of the tool should be positioned over the open cavity next to the idle air bleed valve.

See Figure 6C1-42



**INSTALLING IDLE AIR BLEED VALVE GAGING TOOL**

Figure 6C1-42 Installing Idle Air Bleed Valve Gaging Tool

d. Holding the gaging tool down lightly so that the solenoid plunger is against the solenoid stop, adjust the idle air bleed valve so that the gaging tool will pivot over and just contact the top of the valve.

See Figure 6C1-43

- e. Remove gaging tool.
- f. If NO LETTER appears on the Idle Air Bleed Valve, the final adjustment of this type of idle air bleed valve is made on the vehicle.

See Figure 6C1-24

Refer to "Procedure A" under Idle Mixture Adjustment in the "On Vehicle Service" section.

If a LETTER appears on the Idle Air Bleed Valve, NO FURTHER ADJUSTMENT OF THE IDLE AIR BLEED VALVE IS NECESSARY.

See Figure 6C1-24

The idle mixture is adjusted by the idle mixture needles. Refer to "Procedure B" under Idle Mixture Adjustment in the "On Car Service" section, page 6C1- .

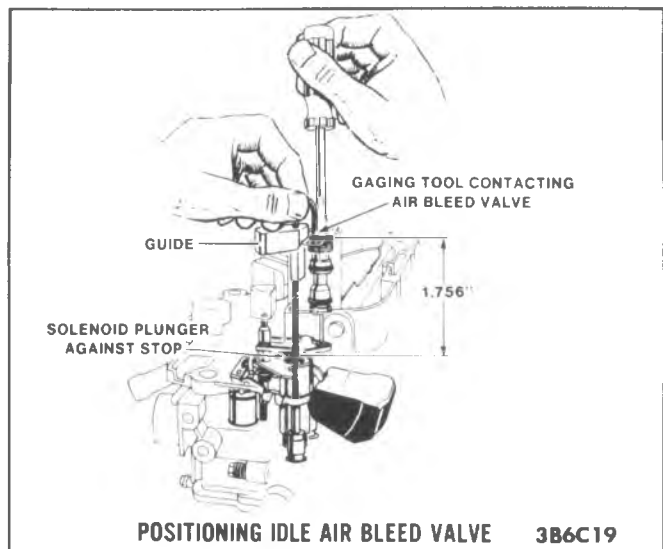

Figure 6C1-43 Positioning Idle Air Bleed Valve

11. Perform adjustments indicated below, which will be found in the Carburetor Adjustment Procedures section:  
Air Valve Spring Adjustment, Figure 6C1-37, and Choke Coil Lever Adjustment, Figure 6C1-38.
12. Install the cover and coil assembly in the choke housing, as follows:
  - a. Place cam follower on highest step of fast idle cam.
  - b. Install the thermostatic cover and coil assembly, and gasket (if used), in the choke housing, making sure coil tang engages the inside coil pick-up lever.

**NOTICE:** On E4ME models, ground contact for the electric choke is provided by a metal plate located at the rear of the choke cover assembly. DO NOT install a choke cover gasket between the electric choke assembly and the choke housing.

- c. A choke cover retainer kit is required to attach the choke cover to the choke housing. Follow instructions found in the kit, and install proper retainer and rivets, using suitable blind rivet tool.

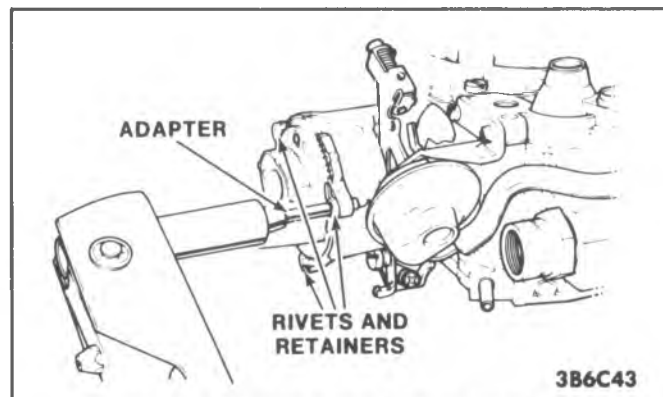

Figure 6C1-44 Installing Choke Cover Rivets

- d. It may be necessary to use an adapter (tube) if the installing tool interferes with the electrical connector tower on the choke cover.

See Figure 6C1-44

- e. On hot air choke models, torque the choke heat pipe nut to 95 in./lbs.

13. Install hose on front vacuum break and on tube on float bowl.
14. Position idle speed solenoid, idle load compensator, or idle speed control, and bracket assembly on float bowl, retaining with two large countersunk screws. Tighten screws securely.
15. Perform the remaining adjustments indicated below, which will be found in the Carburetor Adjustment Procedures section.

See Figures 6C1-45 through 6C1-59

Choke Rod - Fast Idle Cam Adjustment, Figure 6C1-40

Primary (Front) Vacuum Break Adjustment, 6C1-42

Secondary (Rear) Vacuum Break Adjustment, 6C1-43

Air Valve Rod Adjustment - Front, 6C1-44

Air Valve Rod Adjustment - Rear, 6C1-45

Unloader Adjustment, Figure 6C1-46

Secondary Lockout Adjustment, Figure 6C1-47

16. Reinstall carburetor on vehicle with new flange gasket, following vehicle manufacturer's directions.

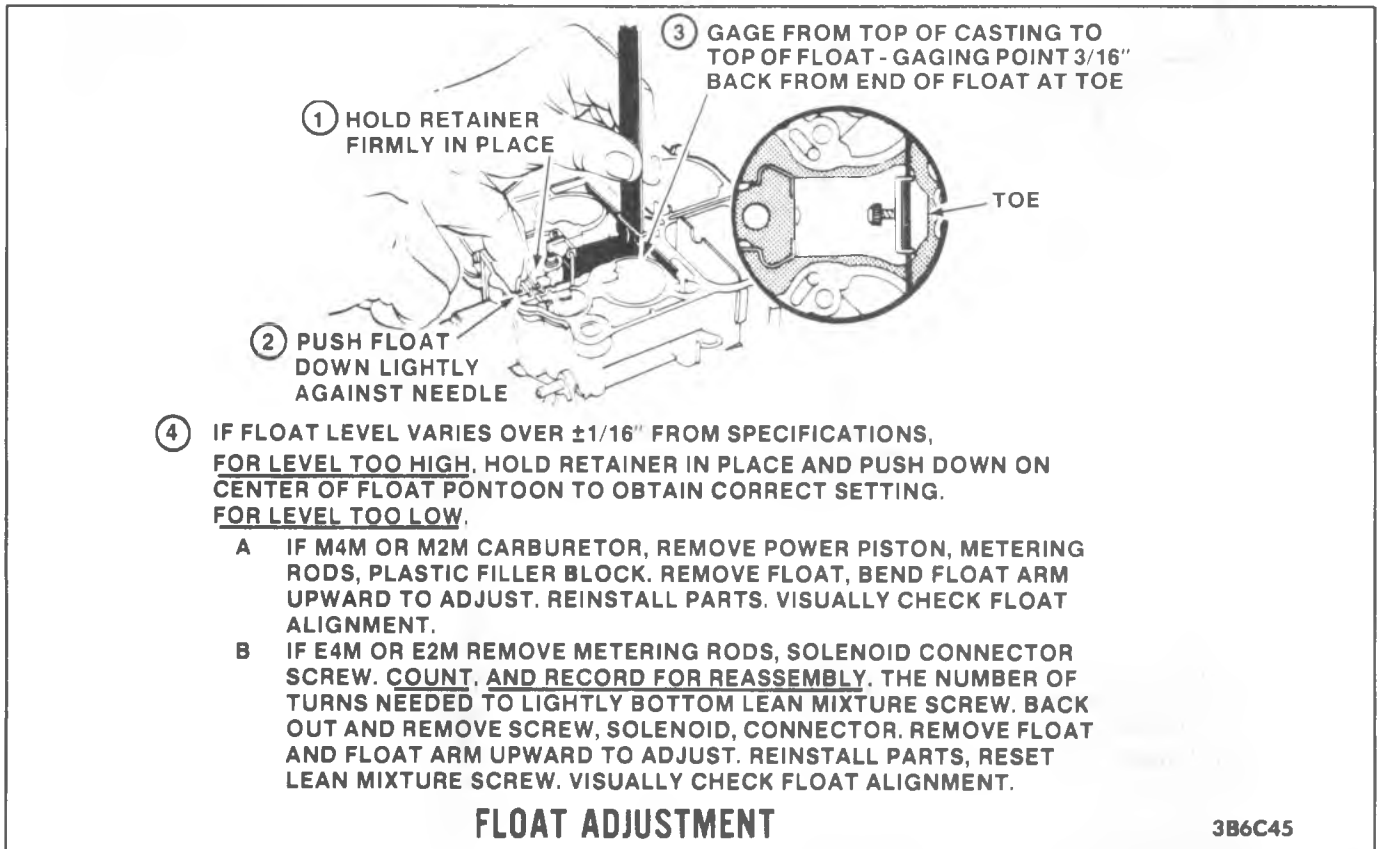
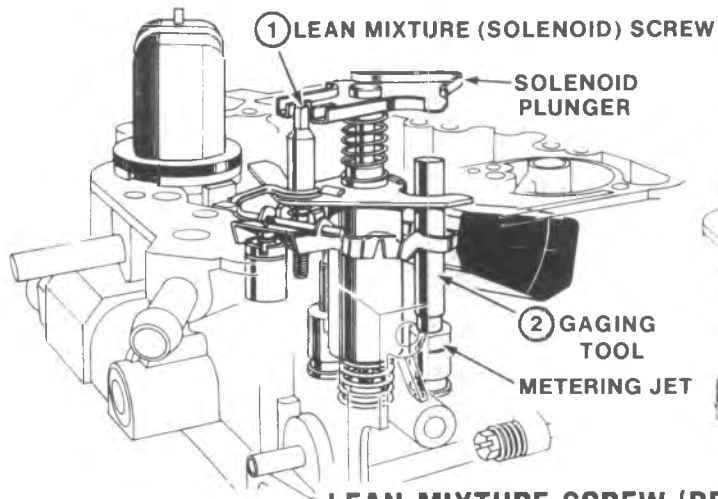
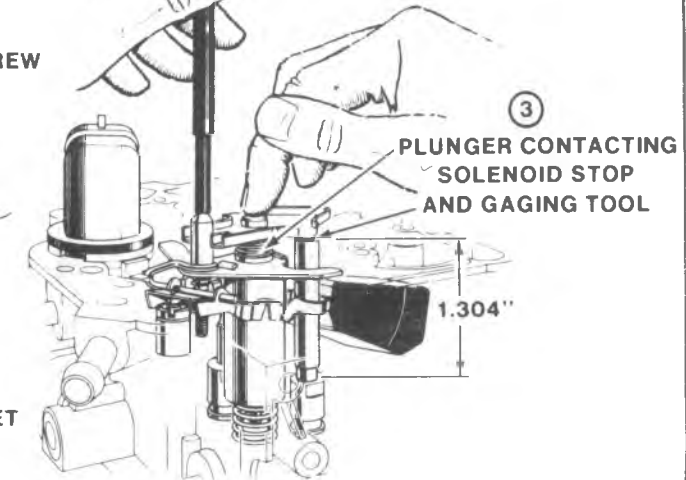

Figure 6C1-45 Float Adjustment

- ① LEAN MIXTURE (SOLENOID) SCREW SHOULD HAVE FIRST SIX THREADS ENGAGED IN FLOAT BOWL TO ASSURE PROPER INSTALLATION.
- ② INSTALL MIXTURE CONTROL SOLENOID GAGING TOOL, J-33815-1, BT-8253-A, OR EQUIVALENT, OVER THE THROTTLE SIDE METERING JET ROD GUIDE, AND TEMPORARILY INSTALL SOLENOID PLUNGER.



- ③ HOLDING THE SOLENOID PLUNGER AGAINST THE SOLENOID STOP, USE TOOL J-28696-10, BT-7928, OR EQUIVALENT, TO TURN THE LEAN MIXTURE (SOLENOID) SCREW SLOWLY CLOCKWISE, UNTIL THE SOLENOID PLUNGER JUST CONTACTS THE GAGING TOOL.



### LEAN MIXTURE SCREW (BENCH) ADJUSTMENT

E2M & E4M MODELS ONLY

3B6C46

Figure 6C1-46 Lean Mixture (Solenoid) Screw Bench Adjustment

- ① WITH LEAN MIXTURE SCREW SET PROPERLY AND AIR HORN REINSTALLED FOLLOWING RECOMMENDED SERVICE PROCEDURES, INSERT TOOL J-9789-130, BT-7720 OR EQUIVALENT IN VERTICAL "D" SHAPED VENT HOLE IN AIR HORN CASTING.
- ② USE TOOL J-28696-10, BT-7928, OR EQUIVALENT, TO TURN RICH MIXTURE STOP SCREW CLOCKWISE UNTIL TOTAL SOLENOID PLUNGER TRAVEL IS  $4/32$ " (3.175 mm.)
- ③ INSTALL NEW PLUGS PROVIDED IN SERVICE KITS, TO RETAIN RICH MIXTURE STOP SCREW AND LEAN MIXTURE (SOLENOID) SCREW SETTINGS, AND TO PREVENT FUEL VAPOR LOSS.

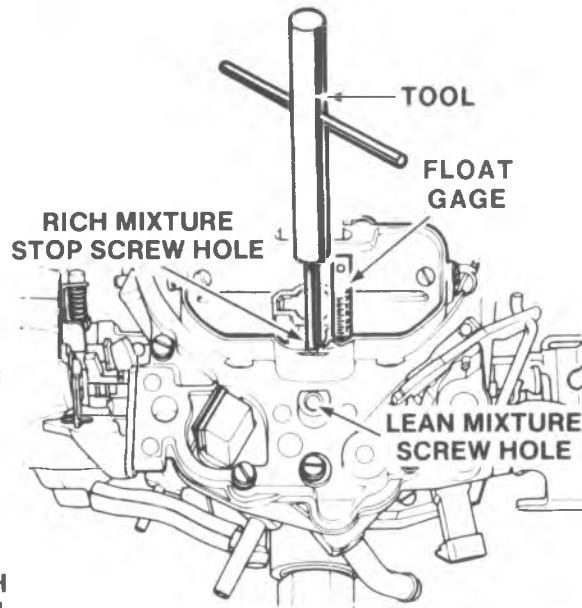

### RICH MIXTURE STOP SCREW (BENCH) ADJUSTMENT

E2M & E4M MODELS ONLY

3B6C47

Figure 6C1-47 Rich Mixture Stop Screw Bench Adjustment

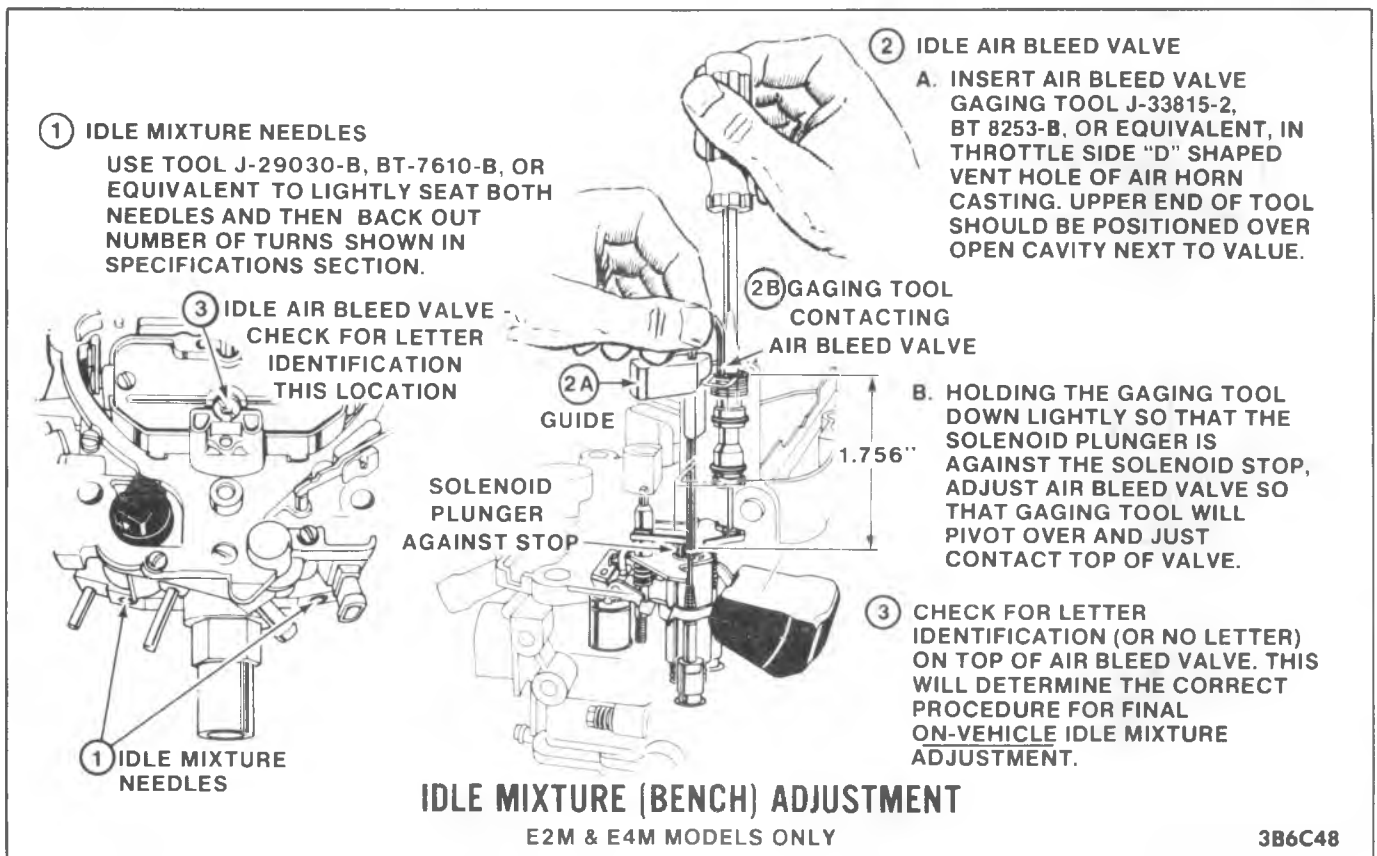

Figure 6C1-48 Idle Mixture Bench Adjustments

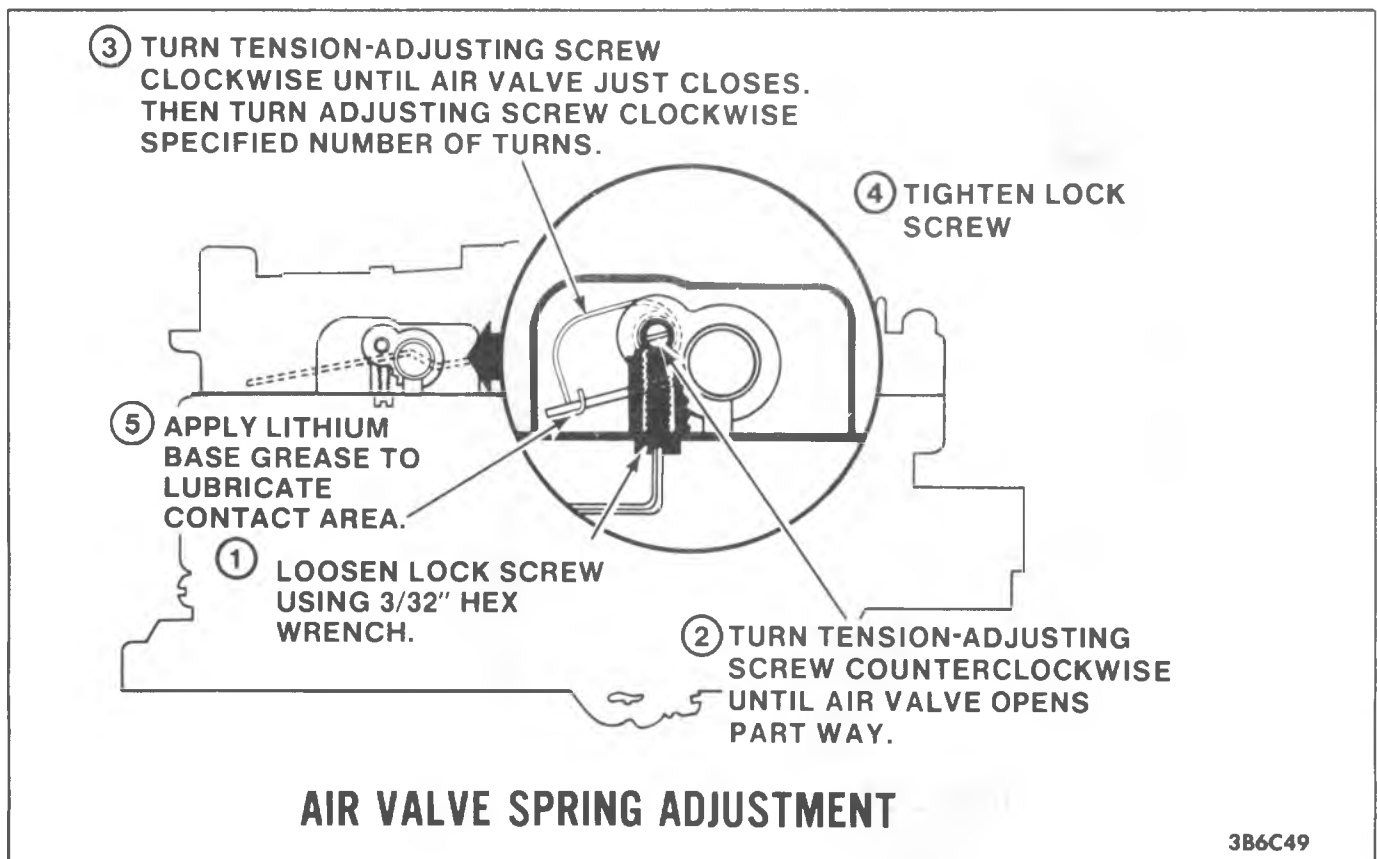

Figure 6C1-49 Air Valve Spring Adjustment

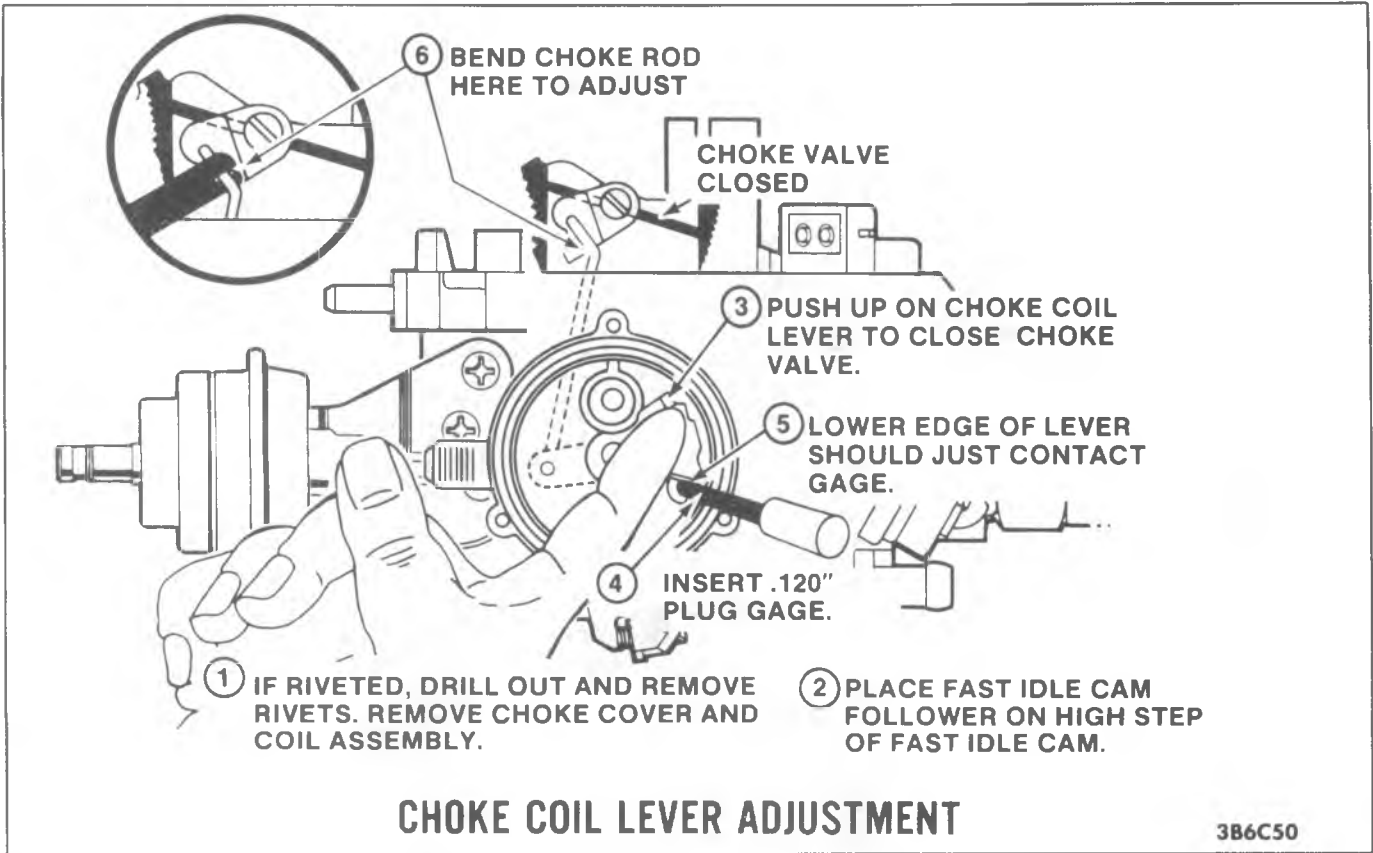

Figure 6C1-50 Choke Coil Lever Adjustment

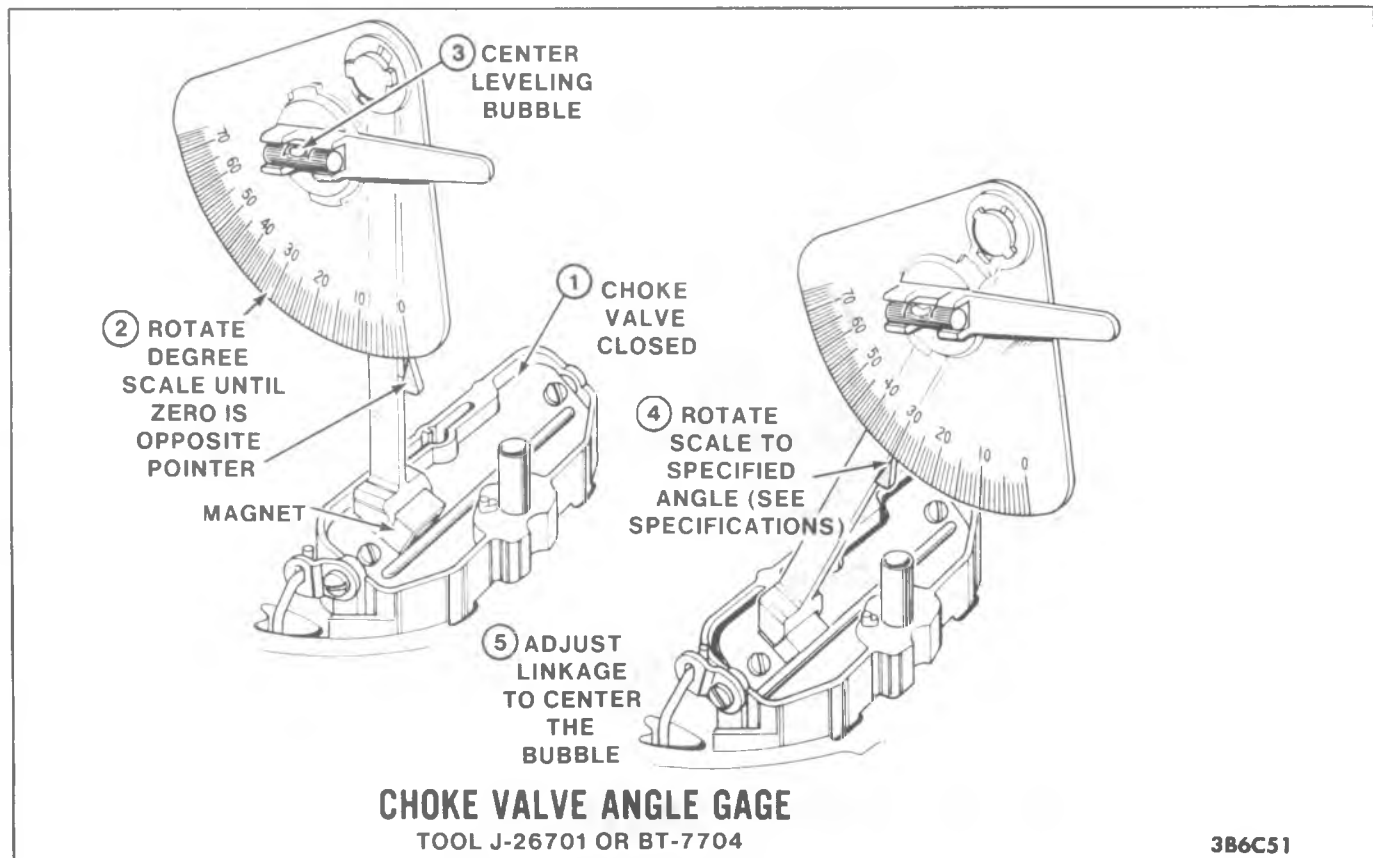
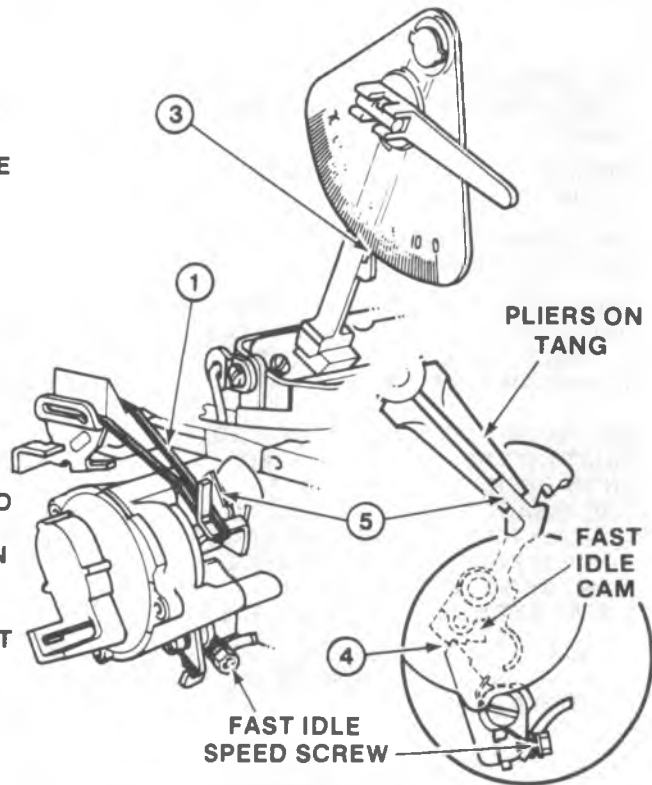

Figure 6C1-51 Choke Valve Angle Gage

- ① ATTACH RUBBER BAND TO GREEN TANG OF INTERMEDIATE CHOKE SHAFT
  - ② OPEN THROTTLE TO ALLOW CHOKE VALVE TO CLOSE
  - ③ SET UP ANGLE GAGE AND SET ANGLE TO SPECIFICATIONS
  - ④ PLACE CAM FOLLOWER ON SECOND STEP OF CAM, AGAINST RISE OF HIGH STEP. IF CAM FOLLOWER DOES NOT CONTACT CAM, TURN IN FAST IDLE SPEED SCREW ADDITIONAL TURN(S).
- NOTICE:** FINAL FAST IDLE SPEED ADJUSTMENT MUST BE PERFORMED ACCORDING TO UNDER-HOOD EMISSION CONTROL INFORMATION LABEL.
- ⑤ ADJUST BY BENDING TANG OF FAST IDLE CAM UNTIL BUBBLE IS CENTERED.



### CHOKE ROD - FAST IDLE CAM ADJUSTMENT

3B6C52

Figure 6C1-52 Choke Rod - Fast Idle Cam Adjustment

### PLUGGING AIR BLEED HOLES

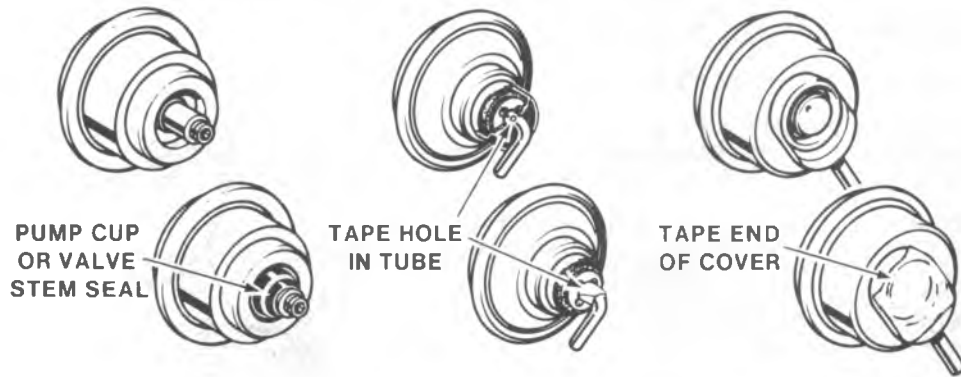

### BUCKING SPRINGS

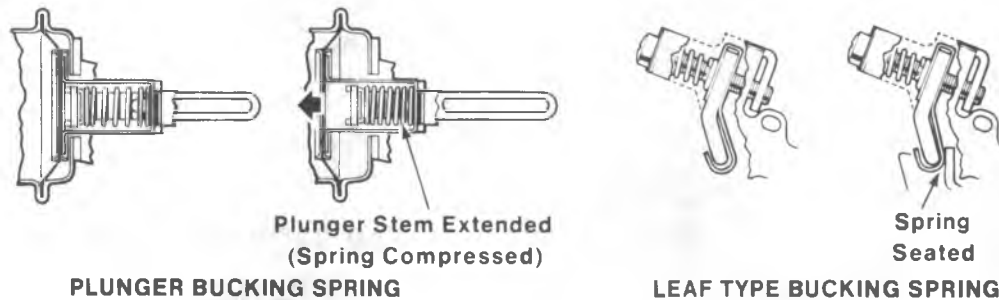

### VACUUM BREAK ADJUSTMENT INFORMATION

3B6C53

Figure 6C1-53 Vacuum Break Adjustment Information

- ① ATTACH RUBBER BAND TO GREEN TANG OF INTERMEDIATE CHOKE SHAFT
- ② OPEN THROTTLE TO ALLOW CHOKE VALVE TO CLOSE
- ③ SET UP ANGLE GAGE AND SET TO SPECIFICATION
- ④ RETRACT VACUUM BREAK PLUNGER USING VACUUM SOURCE, AT LEAST 18" HG. PLUG AIR BLEED HOLES WHERE APPLICABLE

ON QUADRAJETS, AIR VALVE ROD MUST NOT RESTRICT PLUNGER FROM RETRACTING FULLY. IF NECESSARY, BEND ROD (SEE ARROW) TO PERMIT FULL PLUNGER TRAVEL. FINAL ROD CLEARANCE MUST BE SET AFTER VACUUM BREAK SETTING HAS BEEN MADE.

- ⑤ WITH AT LEAST 18" HG STILL APPLIED, ADJUST SCREW TO CENTER BUBBLE

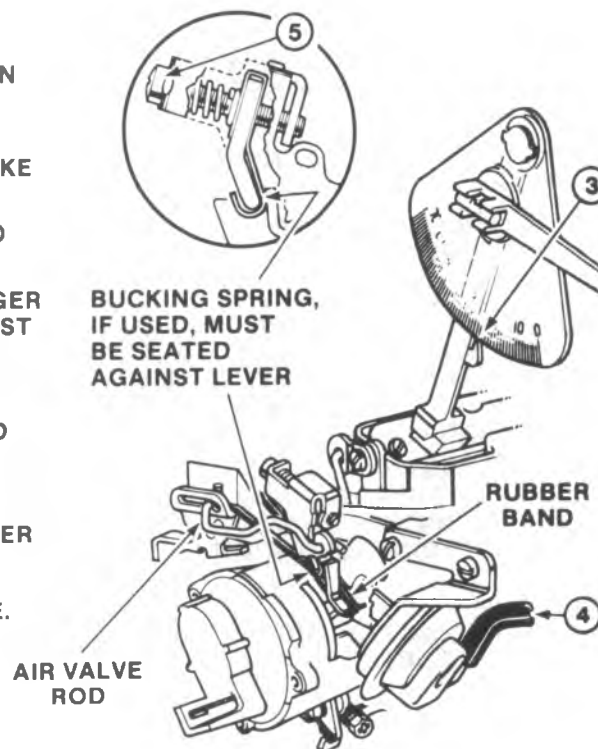

## FRONT VACUUM BREAK ADJUSTMENT

3B6C54

Figure 6C1-54 Front (Primary) Vacuum Break Adjustment

- ① ATTACH RUBBER BAND TO GREEN TANG OF INTERMEDIATE CHOKE SHAFT.
- ② OPEN THROTTLE TO ALLOW CHOKE VALVE TO CLOSE.
- ③ SET UP ANGLE GAGE AND SET ANGLE TO SPECIFICATION.
- ④ RETRACT VACUUM BREAK PLUNGER, USING VACUUM SOURCE, AT LEAST 18" HG. PLUG AIR BLEED HOLES WHERE APPLICABLE.
- ④A ON QUADRAJETS, AIR VALVE ROD MUST NOT RESTRICT PLUNGER FROM RETRACTING FULLY. IF NECESSARY, BEND ROD HERE TO PERMIT FULL PLUNGER TRAVEL. WHERE APPLICABLE, PLUNGER STEM MUST BE EXTENDED FULLY TO COMPRESS PLUNGER BUCKING SPRING.
- ⑤ TO CENTER BUBBLE, EITHER:
  - A. ADJUST WITH 1/8" HEX WRENCH (VACUUM STILL APPLIED)
  - OR-
  - B. SUPPORT AT "S" AND BEND VACUUM BREAK ROD (VACUUM STILL APPLIED)

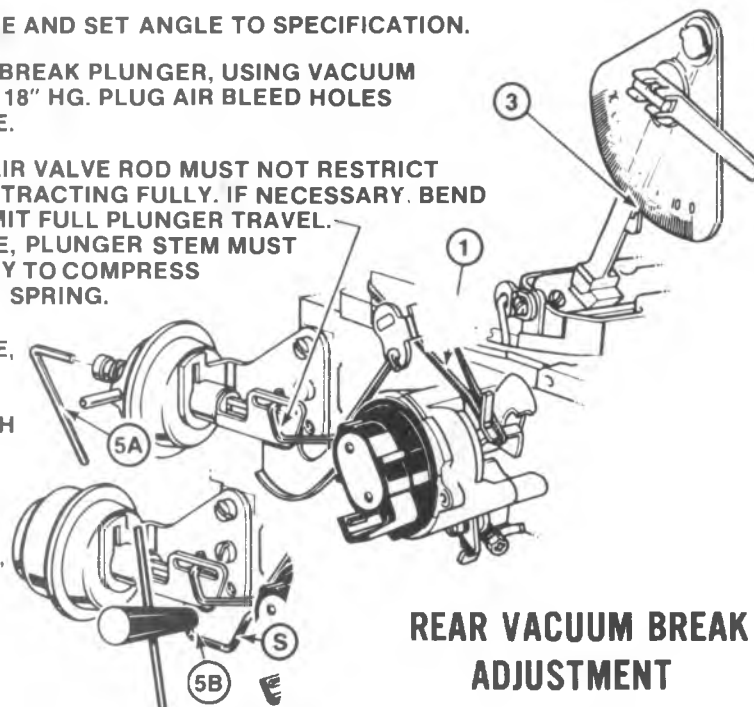

## REAR VACUUM BREAK ADJUSTMENT

3B6C55

Figure 6C1-55 Rear (Auxiliary) Vacuum Break Adjustment

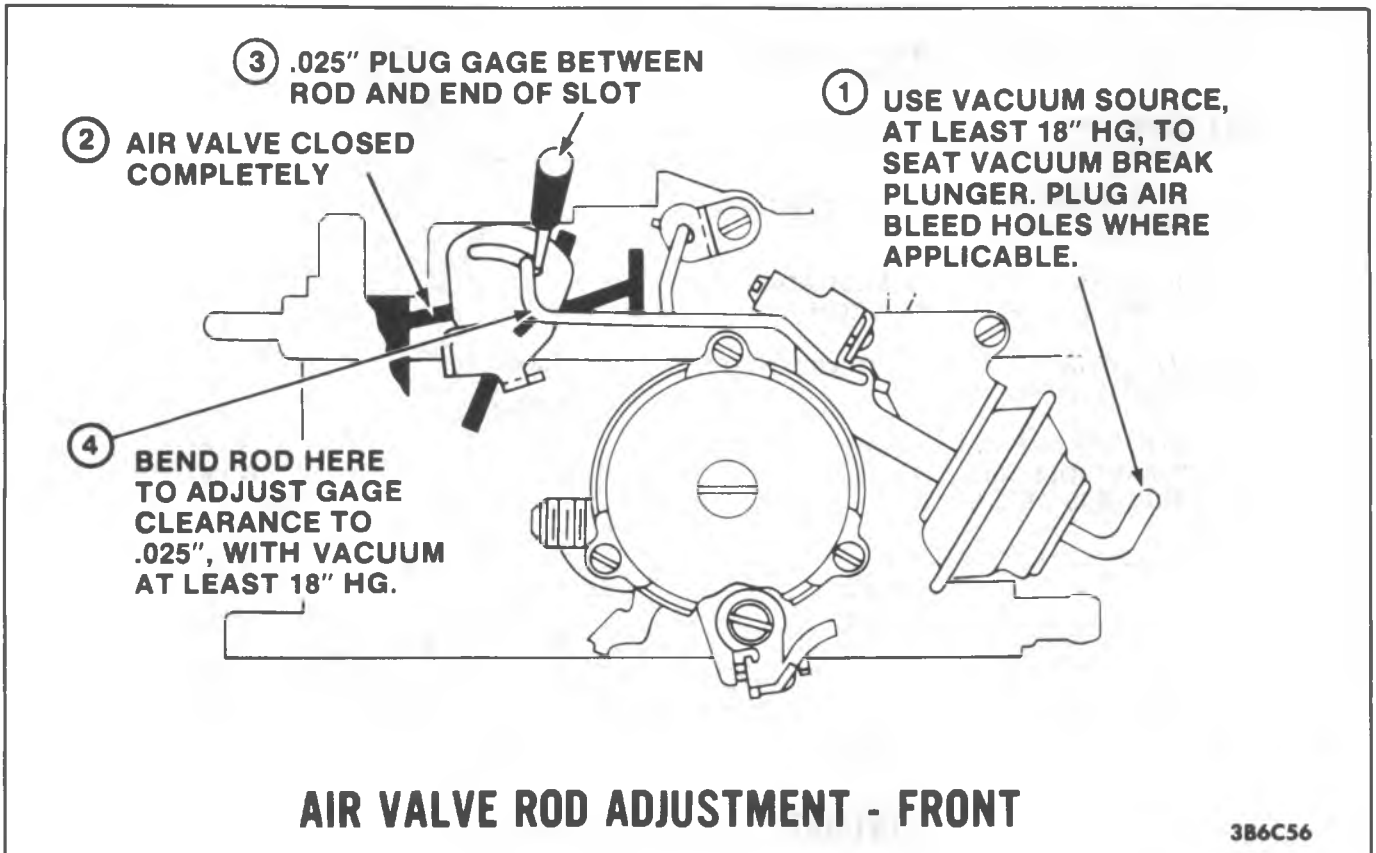

Figure 6C1-56 Air Valve Rod Adjustment - Front

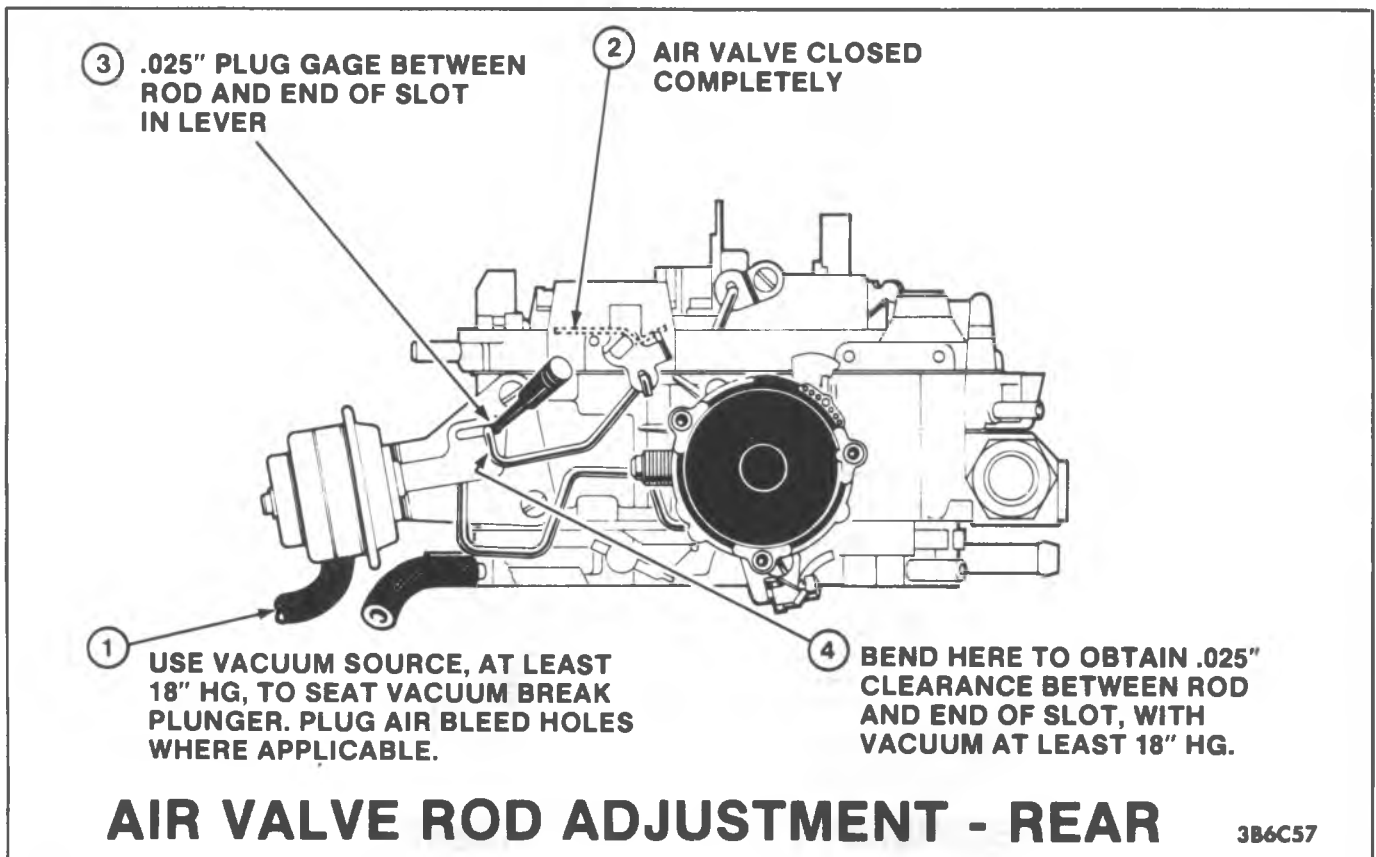
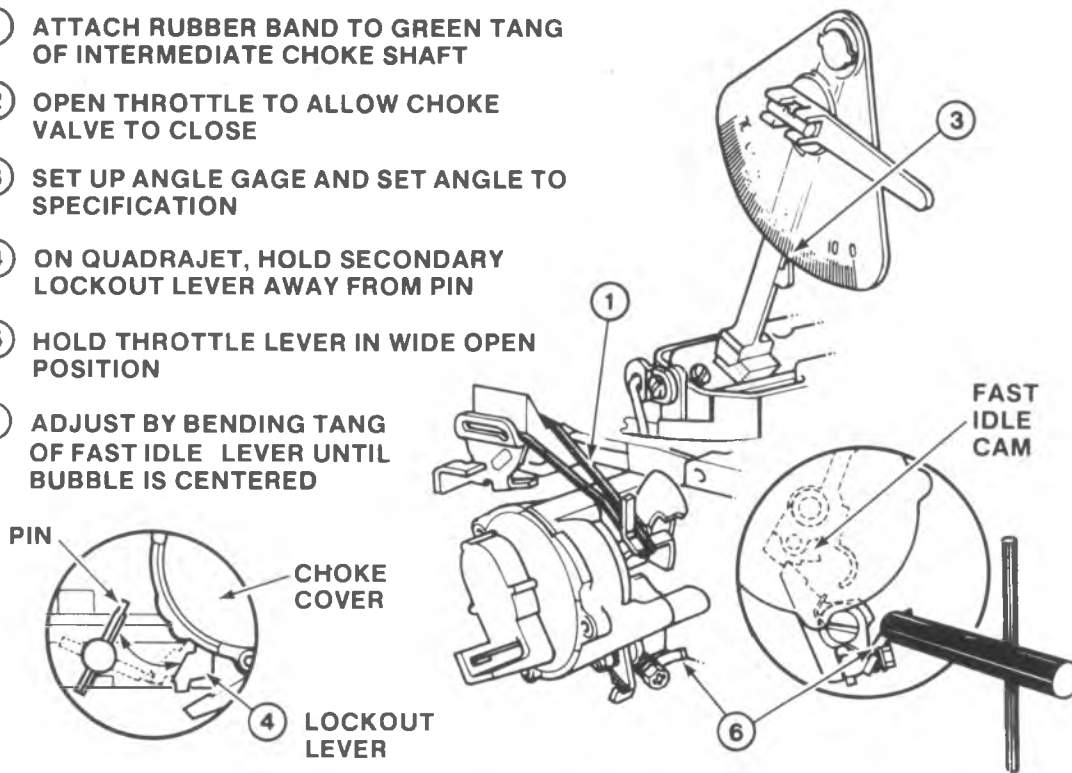

Figure 6C1-57 Air Valve Rod Adjustment - Rear



- ① ATTACH RUBBER BAND TO GREEN TANG OF INTERMEDIATE CHOKE SHAFT
- ② OPEN THROTTLE TO ALLOW CHOKE VALVE TO CLOSE
- ③ SET UP ANGLE GAGE AND SET ANGLE TO SPECIFICATION
- ④ ON QUADRAJET, HOLD SECONDARY LOCKOUT LEVER AWAY FROM PIN
- ⑤ HOLD THROTTLE LEVER IN WIDE OPEN POSITION
- ⑥ ADJUST BY BENDING TANG OF FAST IDLE LEVER UNTIL BUBBLE IS CENTERED



### UNLOADER ADJUSTMENT

3B6C58

Figure 6C1-58 Unloader Adjustment

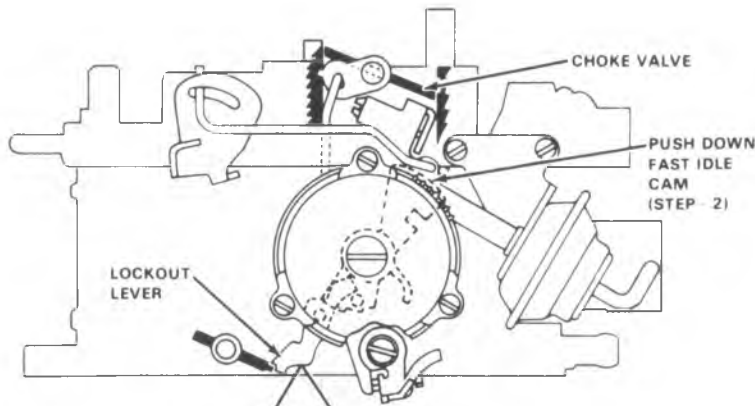

|   |   |
|---|---|
| <p>CHOKE VALVE CLOSED<br/>THROTTLE VALVES CLOSED</p> <p>BEND PIN TO ADJUST<br/>0.015 MAX. CLEARANCE</p> <p>① SECONDARY LOCKOUT LEVER SIDE CLEARANCE</p> | <p>HOLD CHOKE VALVE WIDE OPEN BY PUSHING DOWN ON TAIL OF FAST IDLE CAM</p> <p>CHECK LOCKOUT PIN FOR CLEARANCE</p> <p>FILE END OF PIN FOR CLEARANCE (CHECK FOR NO BURRS AFTER FILING)</p> <p>② SECONDARY LOCKOUT OPENING CLEARANCE</p> |
|---|---|

### SECONDARY LOCKOUT ADJUSTMENT

3B6C59

Figure 6C1-59 Secondary Lockout Adjustment

## MODEL E4ME CARBURETOR ADJUSTMENT SPECIFICATIONS — 5.0L ENGINE

| CARBU-RETOR NUMBER | FLOAT LEVEL   | CHOKE ROD CAM | VACUUM BREAK REAR | AIR VALVE SPRING (NO. OF TURNS) | UNLOADER | LEAN MIXTURE SCREW | IDLE AIR BLEED VALVE | IDLE MIXTURE NEEDLE (NO. OF TURNS) |
|--------------------|---------------|---------------|-------------------|---------------------------------|----------|--------------------|----------------------|------------------------------------|
| 17083202           | 8.7mm (11/32) | 20°           | 27°               | 7/8                             | 38°      | 1.304 GAGE         | NO LETTER ①          | 3-3/8                              |
| 17083203           | 8.7mm (11/32) | 38°           | 27°               | 7/8                             | 38°      | 1.304 GAGE         | NO LETTER ①          | 3-3/8                              |
| 17083204           | 8.7mm (11/32) | 20°           | 27°               | 7/8                             | 38°      | 1.304 GAGE         | NO LETTER ①          | 3-3/8                              |
| 17083207           | 8.7mm (11/32) | 38°           | 27°               | 7/8                             | 38°      | 1.304 GAGE         | NO LETTER ①          | 3-3/8                              |
| 17083216           | 8.7mm (11/32) | 20°           | 27°               | 7/8                             | 38°      | 1.304 GAGE         | NO LETTER ①          | 3-3/8                              |
| 17083218           | 8.7mm (11/32) | 20°           | 27°               | 7/8                             | 38°      | 1.304 GAGE         | NO LETTER ①          | 3-3/8                              |
| 17083236           | 8.7mm (11/32) | 20°           | 27°               | 7/8                             | 38°      | 1.304 GAGE         | 1.756 GAGE           | ②                                  |

① PRESET WITH 1.756 GAGE AND FINAL ADJUSTMENT ON VEHICLE

② PRESET 3 TURNS AND FINAL ADJUSTMENT ON VEHICLE

## MODEL E4ME CARBURETOR ADJUSTMENT SPECIFICATIONS—5.0L/5.7L ENGINE

| CARBU-RETOR NUMBER | FLOAT LEVEL   | CHOKE ROD CAM | VACUUM BREAK FRONT | VACUUM BREAK REAR | AIR VALVE SPRING (NO. OF TURNS) | UNLOADER | LEAN MIXTURE SCREW | IDLE AIR BLEED VALVE | IDLE MIXTURE NEEDLE (NO. OF TURNS) |
|--------------------|---------------|---------------|--------------------|-------------------|---------------------------------|----------|--------------------|----------------------|------------------------------------|
| 17083506           | 11.0mm (7/16) | 20°           | 27°                | 36°               | 7/8                             | 36°      | 1.304 GAGE         | 1.756 GAGE           | ①                                  |
| 17083508           | 11.0mm (7/16) | 20°           | 27°                | 36°               | 7/8                             | 36°      | 1.304 GAGE         | 1.756 GAGE           | ①                                  |
| 17083524           | 11.0mm (7/16) | 20°           | 25°                | 36°               | 7/8                             | 36°      | 1.304 GAGE         | 1.756 GAGE           | ①                                  |
| 17083526           | 11.0mm (7/16) | 20°           | 25°                | 36°               | 7/8                             | 36°      | 1.304 GAGE         | 1.756 GAGE           | ①                                  |

① PRESET 3 TURNS AND FINAL ADJUSTMENT ON VEHICLE

## THROTTLE POSITION SENSOR

| ENGINE CODE | TPS VOLTAGE | THROTTLE POSITION |
|-------------|-------------|-------------------|
| H (LG4)     | .51 VOLTS   | CURB IDLE         |
| G (LM1)     | .51 VOLTS   | IGNITION "ON"     |
| F (LF3)     | .4 VOLTS    | ENGINE STOPPED    |
| L (LS9)     | .4 VOLTS    | A/C "OFF"         |



## SECTION 6C3

# CARBURETOR MODEL E2SE

### CONTENTS

|   |        |                                 |        |
|---|--------|---------------------------------|--------|
| General Description.....                  | 6C3-1  | Carburetor Mounting Torque..... | 6C3-11 |
| Diagnosis.....                            | 6C3-5  | Fuel Filter Replacement.....    | 6C3-11 |
| On-Vehicle Service.....                   | 6C3-5  | Choke and Hoses.....            | 6C3-12 |
| General.....                              | 6C3-5  | Choke Check Procedure.....      | 6C3-12 |
| Carburetor Identification.....            | 6C3-5  | Secondary Vacuum Break TVS..... | 6C3-13 |
| Float Mechanical Level Check.....         | 6C3-5  | Carburetor Adjustments.....     | 6C3-13 |
| Fast Idle Adjustment.....                 | 6C3-5  | Unit Repair.....                | 6C3-13 |
| Idle Speed Adjustment.....                | 6C3-5  | Disassembly.....                | 6C3-13 |
| Idle Solenoid.....                        | 6C3-5  | Cleaning and Inspection.....    | 6C3-18 |
| Throttle Position Sensor Adjustment.....  | 6C3-8  | Assembly.....                   | 6C3-19 |
| Mixture Control Solenoid Replacement..... | 6C3-8  | Adjustments.....                | 6C3-22 |
| Idle Mixture Adjustment.....              | 6C3-9  | Special Tools.....              | 6C3-28 |
| Mixture Adjustment Procedure.....         | 6C3-10 | Adjustment Specifications.....  | 6C3-28 |
| Carburetor Replacement.....               | 6C3-11 |                                 |        |

ALL NEW GM VEHICLES ARE CERTIFIED BY THE UNITED STATES ENVIRONMENTAL PROTECTION AGENCY AS CONFORMING TO THE REQUIREMENTS OF THE REGULATIONS FOR THE CONTROL OF AIR POLLUTION FROM NEW MOTOR VEHICLES. THIS CERTIFICATION IS CONTINGENT ON CERTAIN ADJUSTMENTS BEING SET TO FACTORY STANDARDS. IN MOST CASES, THESE ADJUSTMENT POINTS EITHER HAVE BEEN PERMANENTLY SEALED AND/OR MADE INACCESSIBLE TO PREVENT INDISCRIMINATE OR ROUTINE ADJUSTMENT IN THE FIELD. FOR THIS REASON, THE FACTORY PROCEDURE FOR TEMPORARILY REMOVING PLUGS, CAP, ETC., FOR PURPOSES OF SERVICING THE PRODUCT, MUST BE STRICTLY FOLLOWED AND, WHEREVER PRACTICABLE, RETURNED TO THE ORIGINAL INTENT OF THE DESIGN.

For vehicles sold in Canada and equipped with non-closed loop engines, also refer to the appropriate Canadian Service Manual Supplement.

## GENERAL DESCRIPTION

The Model E2SE carburetor is a two barrel, two stage carburetor of down-draft design used with the Computer Command Control system of fuel control (see Section 6E for system description).

The carburetor comprises of three major assemblies: the air horn, the float bowl and throttle body.

It has six basic operating systems (Figs. 6C3-1 to 6C3-6).

- Float
- Idle
- Main Metering
- Power
- Pump
- Choke

A single float chamber supplies fuel to both carburetor bores. A closed-cell rubber float, brass needle seat and rubber tip float valve with pull clip are used to control fuel level in the float chamber. In some cases, a float stabilizing

spring has been added to further control fuel level when the vehicle is used in rugged terrain.

An electrically operated mixture control solenoid, mounted in the air horn and extended into the float bowl, is used to control air and fuel mixture in the primary bore of the carburetor. A plunger in the end of the solenoid is submerged in fuel in the fuel chamber of the float bowl. The plunger is controlled (or "pulsed") by electrical signals received from the Electronic Control Module (ECM).

An air valve and metering rod control the air/fuel metering in the secondary bore of the carburetor. The tapered metering rod is attached to the air valve, and provide the additional fuel flow necessary during increased engine air flow at wide open throttle.

The pump system uses a pump, plunger and a thermostatically controlled bypass valve to provide extra fuel during quick throttle opening. The bypass valve is pressed into the air horn casting and contains a temperature sensitive snap disk. During cold engine start-up, the pump delivers at full capacity to the primary bore of the

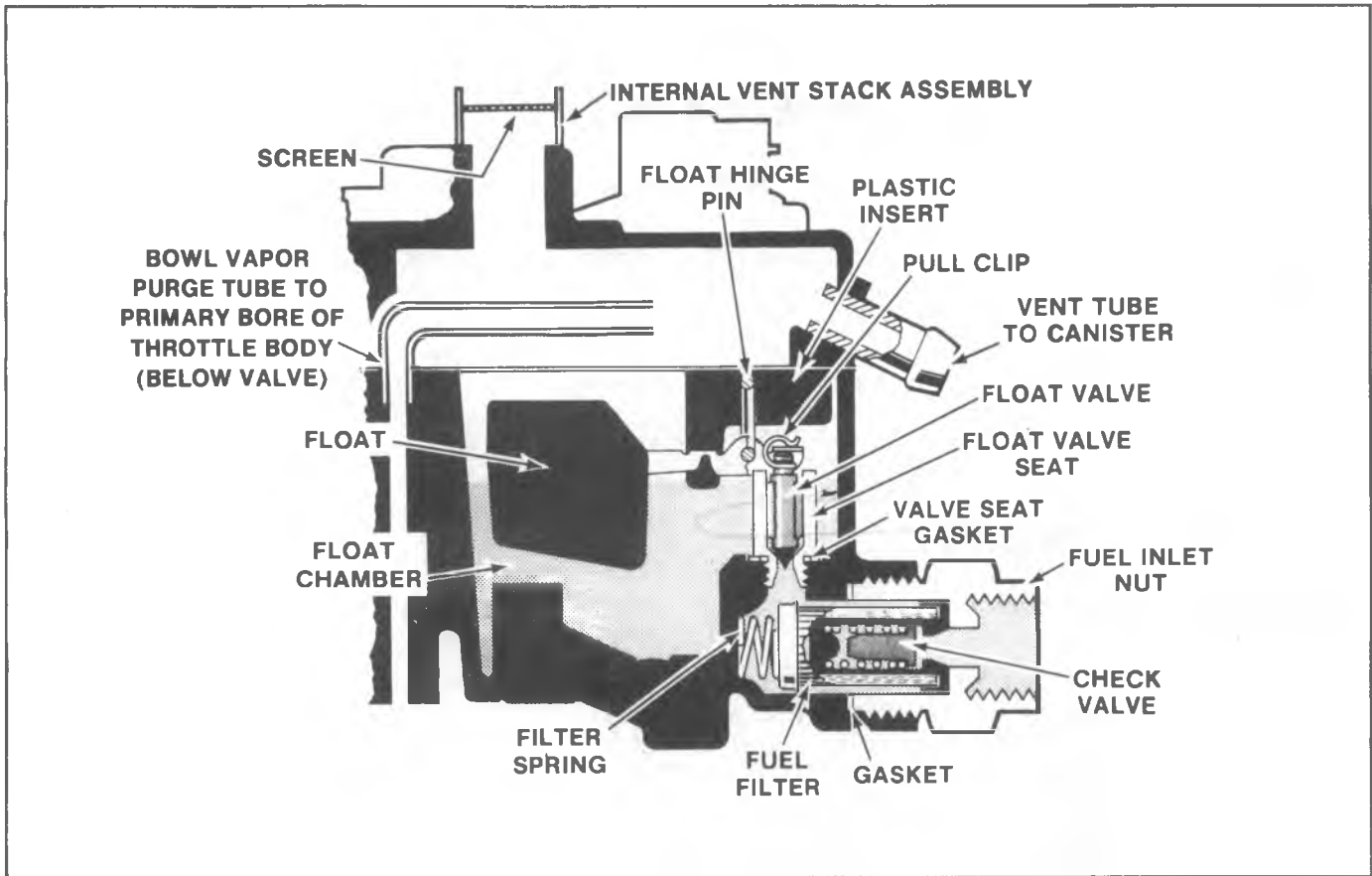

Fig. 6C3-1 Float System

carburetor. At normal engine operating temperatures, the bypass valve opens, allowing a portion of the fuel to be pumped back to the float bowl.

An electrically heated choke coil provides the choke valve closing force for cold start-up and for correct opening timing during warmup. Dual vacuum break units control initial choke valve opening at start up during varied ambient temperatures.

A throttle lever unloader tang forces the choke valve open to purge a flooded engine when the accelerator is pressed to the floor. A fast idle cam, following choke valve movement, acts as a graduated throttle stop to provide increased idle speed during warmup.

On some models, at hot idle compensator valve assembly is located in the air horn casting. The opening and

closing of the hot idle compensator valve is controlled by a bi-metal strip which is calibrated to a specific temperature. When the valve opens, additional air is allowed to bypass the throttle valves, and enters the intake manifold, to prevent rough idling during periods of hot engine operation.

The Model E2SE carburetor has a throttle position sensor (TPS) mounted in the float bowl and is used to signal the ECM as throttle position changes occur. As throttle position is changed, a tang on the pump lever move the TPS plunger modifying an electrical signal to the ECM. This signal is used by the ECM to control various engine operating modes.

An Idle Speed Solenoid is used to position the primary throttle valve to provide engine idle speed requirements.

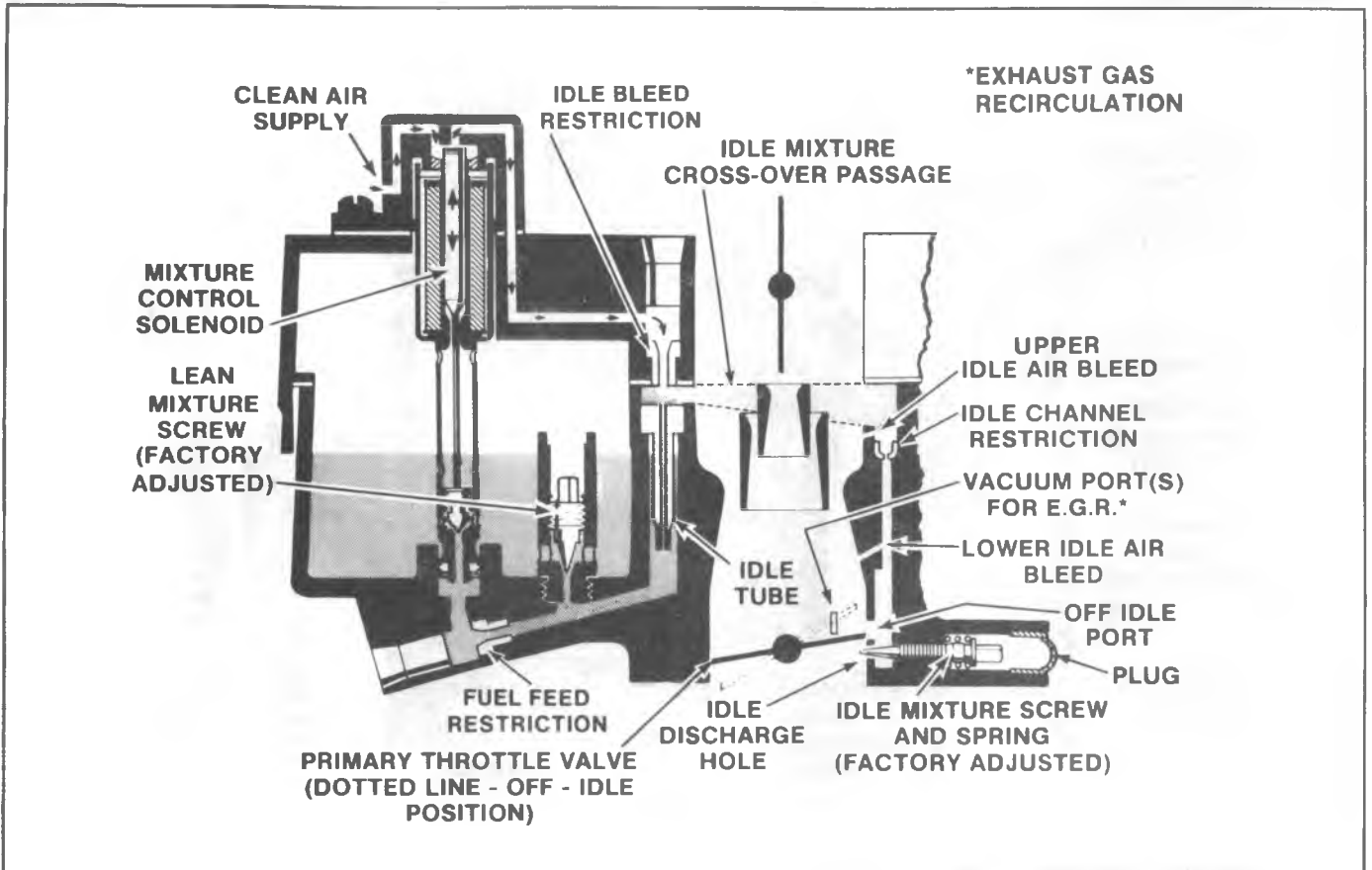

Fig. 6C3-2 Idle System

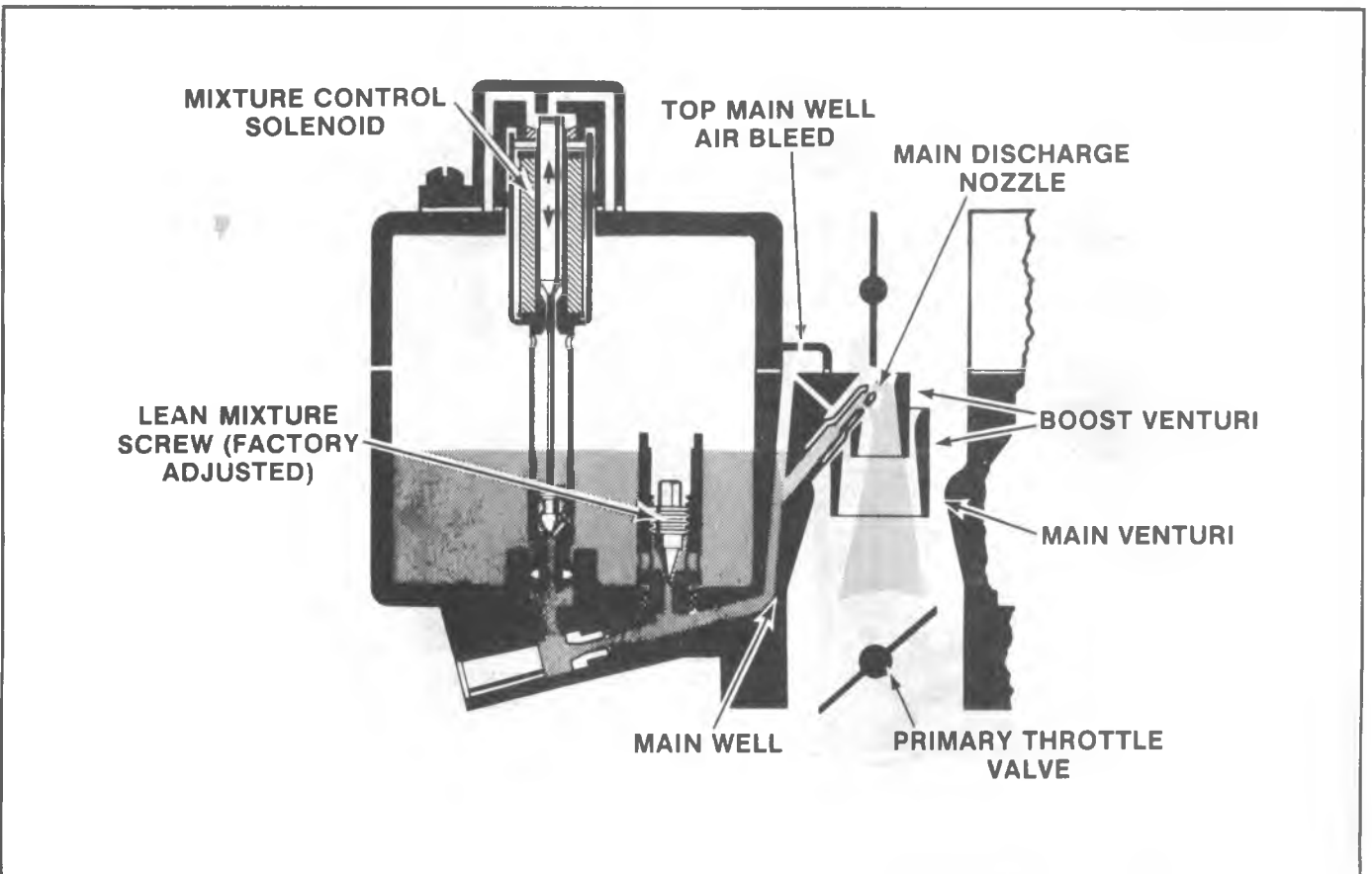

Fig. 6C3-3 Main Metering System

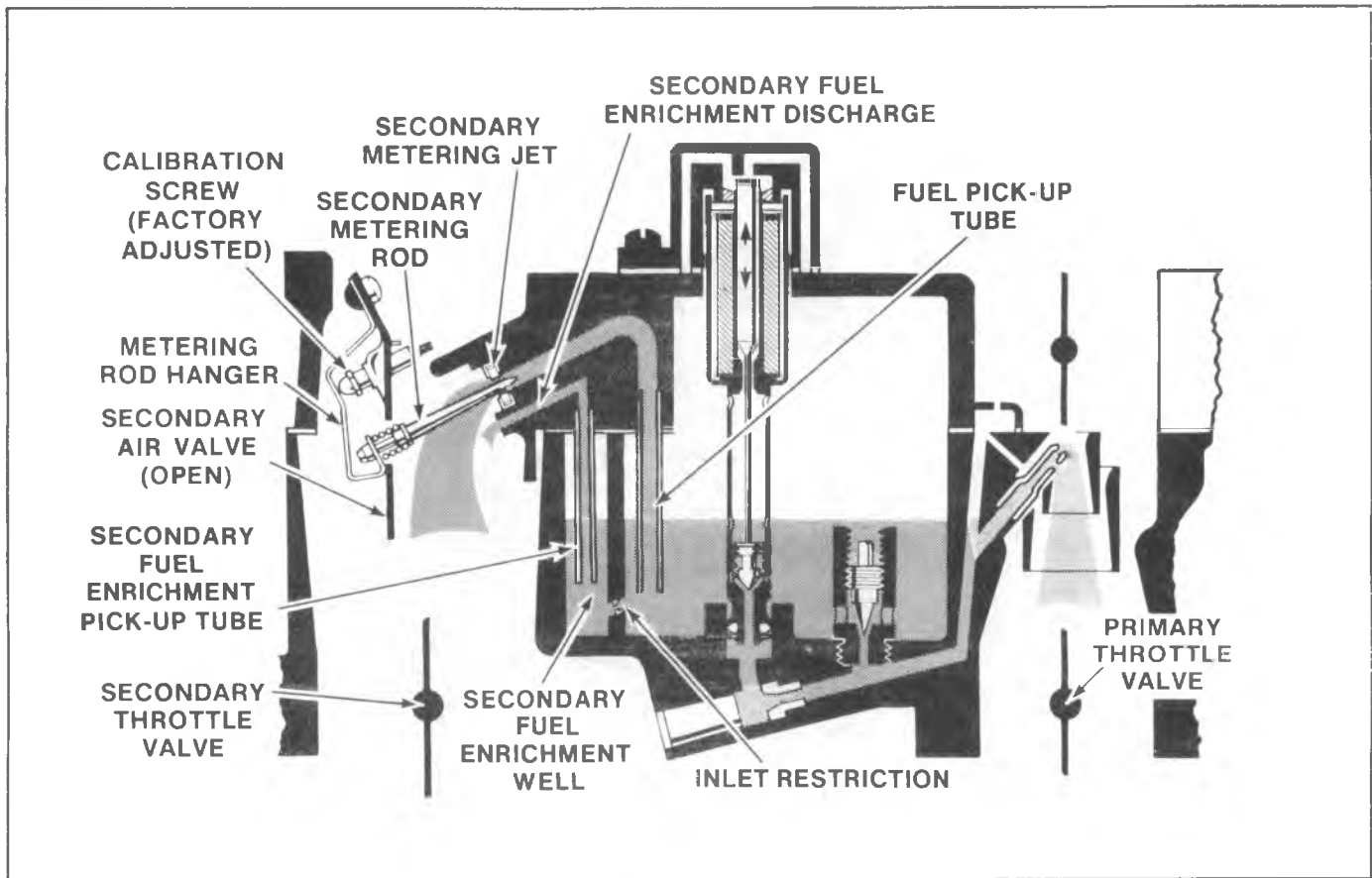

Fig. 6C3-4 Power System

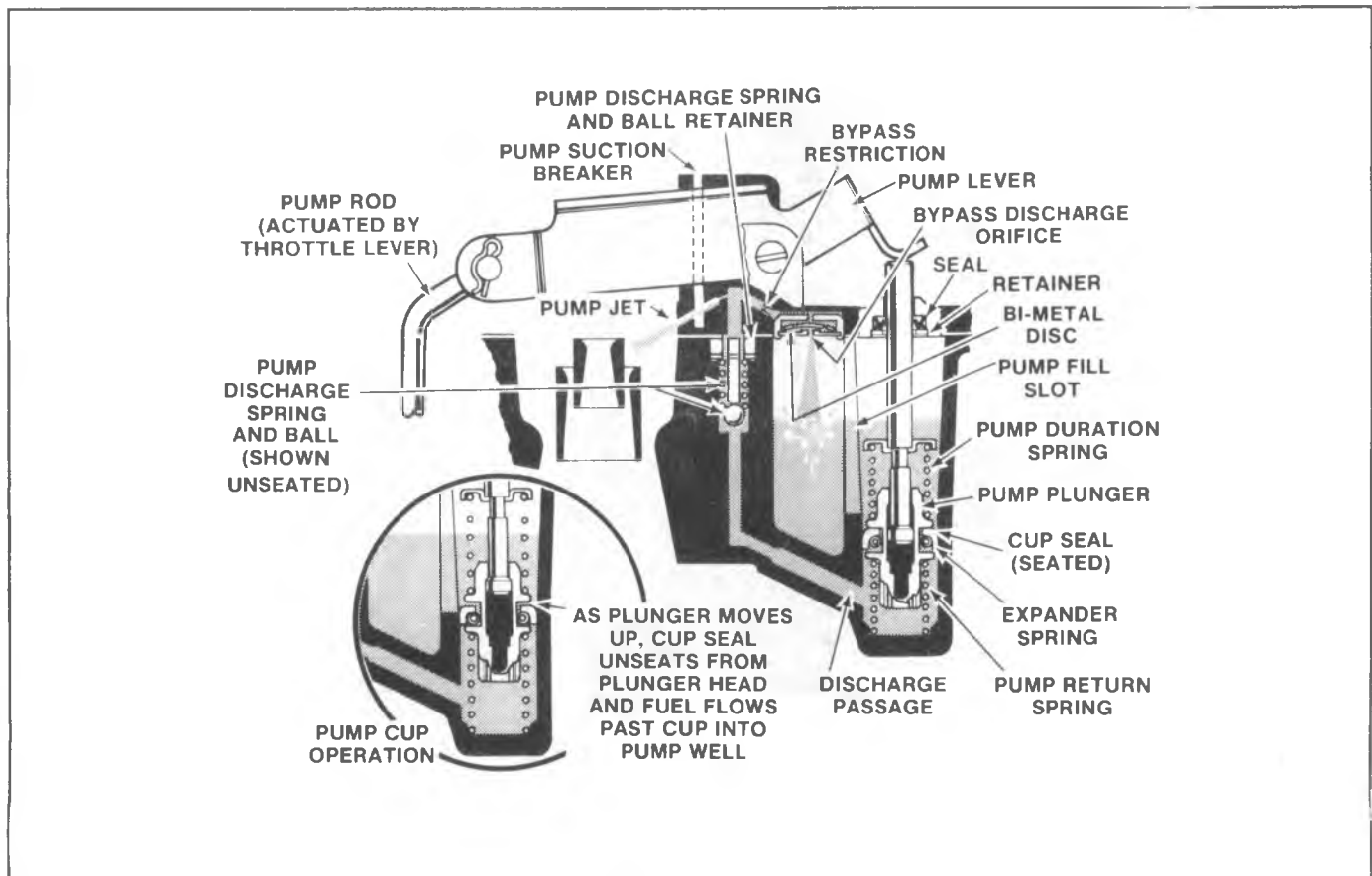

Fig. 6C3-5 Pump System

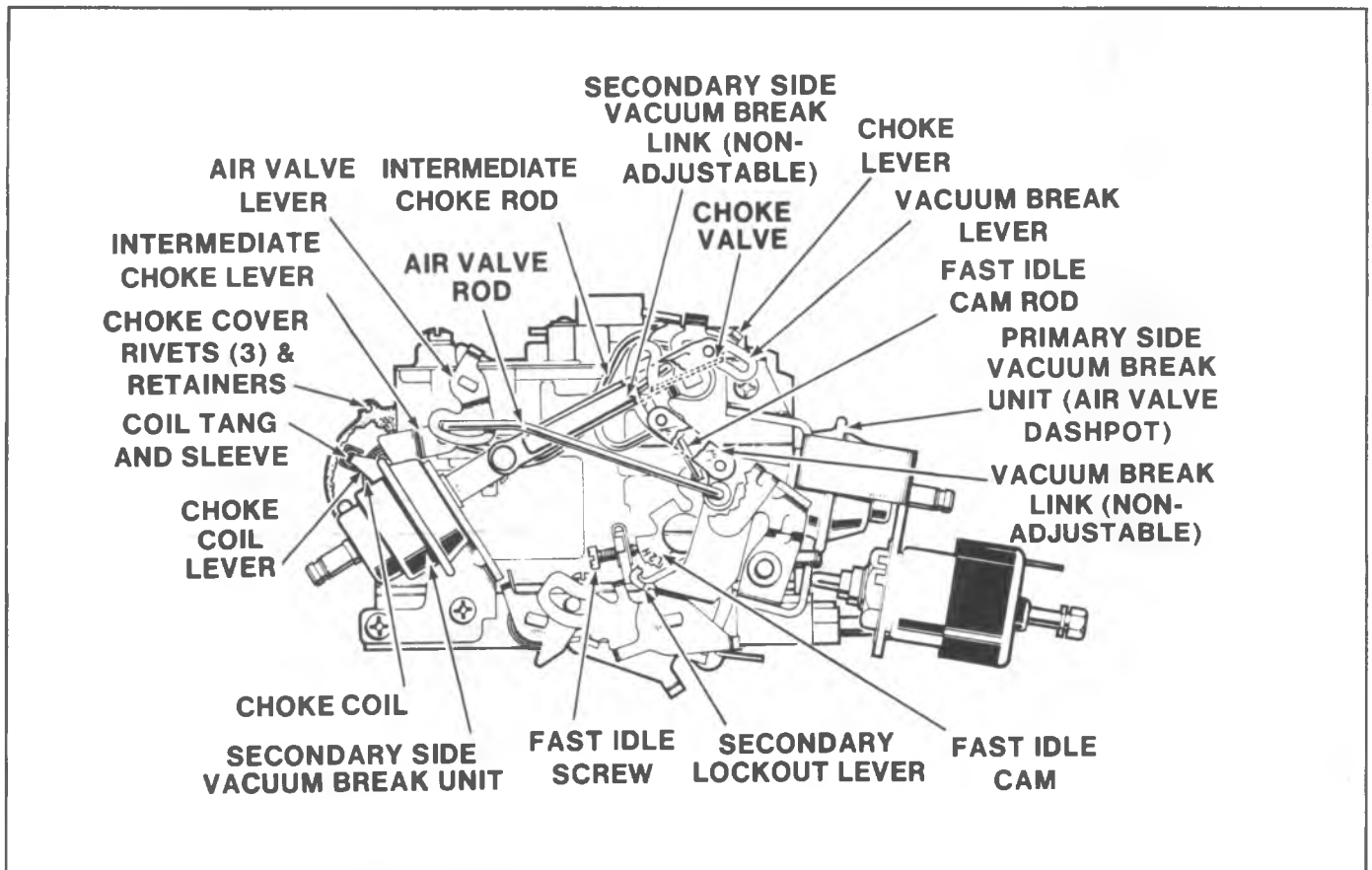

Fig. 6C3-6 Choke System

## DIAGNOSIS

Refer to Engine Performance Diagnosis (Section 6), Fuel System Diagnosis (Section 6C) and/or Cleaning and Inspection under Unit Repair in this section.

## ON-VEHICLE SERVICE

### GENERAL

Before checking or resetting the carburetor as the cause of poor engine performance or rough idle; check ignition system including distributor, timing, spark plugs and wires. Check air cleaner, evaporative emission control (EEC) system, EFE System, PCV system, EGR valve and engine compression. Also inspect intake manifold, vacuum hoses and connections for leaks and check torques of carburetor mounting bolts/nuts.

Make all adjustments with engine at normal operating temperature, emission control system in closed loop mode, choke full open, air cleaner removed, and air conditioning off (if equipped). Specifications can be found at the end of this section.

### CARBURETOR IDENTIFICATION

For ease of service, alphabetical code letters are cast into the air horn, float bowl, and throttle body castings at external tube locations to identify hose connections. The carburetor model identification is stamped vertically on the

float bowl in a flat area adjacent to vacuum tube location "B" (see Figure 6C3-7). Refer to this part number when servicing the carburetor.

### FLOAT MECHANICAL LEVEL CHECK

The float level may be checked externally using tool J-9789-130 and referring to Figure 6C3-8.

### FAST IDLE ADJUSTMENT

Refer to the Vehicle Emission Control Information label and Figure 6C3-9 for fast idle adjustment.

### IDLE SPEED ADJUSTMENT

Refer to the Vehicle Emission Control Information label on the vehicle and Figures 6C3-10 and 11 for adjustment procedures and specification information.

### IDLE SOLENOID

The solenoid should be checked to assure that the solenoid plunger extends when the solenoid is energized. An inoperative solenoid could cause stalling or a rough idle when hot, and should be replaced as necessary.



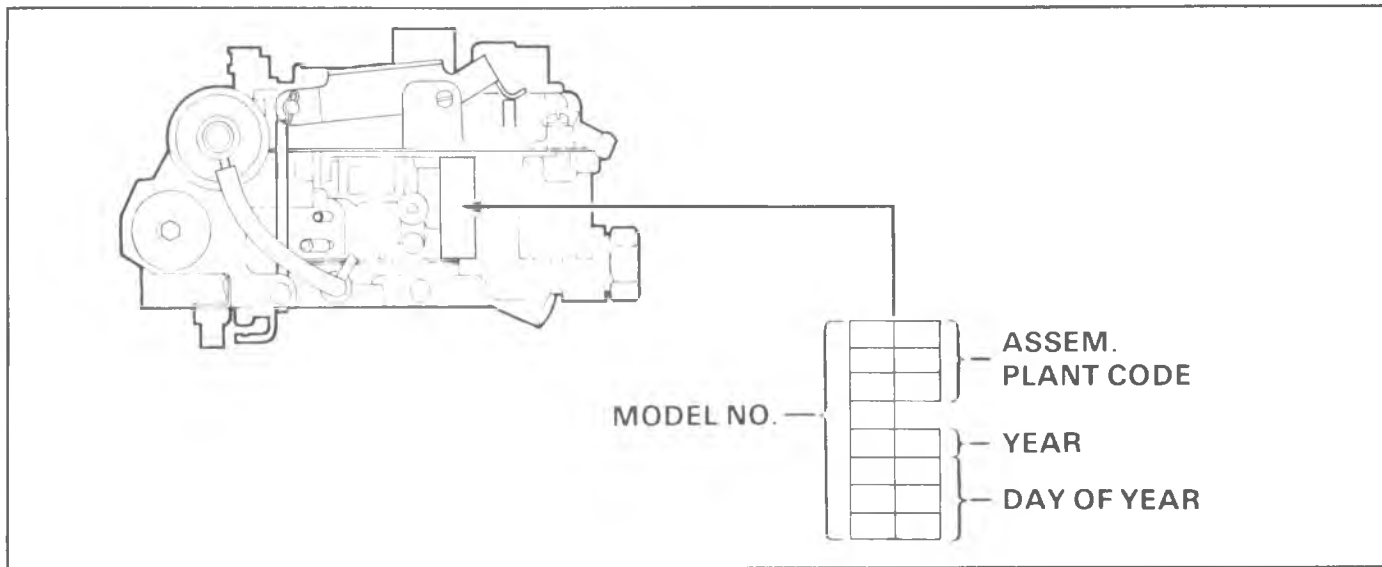

Fig. 6C3-7--Carburetor Identification

**Check**

1. Turn on ignition, but do not start engine. Position transmission lever in Drive (A/T) or Neutral (M/T). On vehicles equipped with air conditioning, A/C switch must be on.
2. Open and close throttle to allow solenoid plunger to extend.
3. Disconnect wire at solenoid. Solenoid plunger should drop away from throttle lever.
4. Connect solenoid wire. Plunger should move out and contact the throttle lever. Solenoid may not be strong enough to open the throttle, but the plunger should move.
5. If plunger does not move in and out as wire is disconnected and connected, check for voltage feed wire:
  - a. If voltage is 12-15 volts, replace solenoid.
  - b. If voltage is low or zero, locate cause of open

- ① REMOVE AIR HORN VENT STACK.
- ② SELECT CORRECT GAGE FROM BT-8104 OR J-9789-135 SERIES FOR CARBURETOR.
- ③ a USING BT-8104 GAGE SERIES, INSERT BRIDGE  
-OR-  
b USING J-9789-135 GAGE SERIES, REMOVE AIR HORN SCREW NEXT TO OPEN VENT.

- ④ WITH ENGINE RUNNING AT IDLE, CHOKE WIDE-OPEN, INSERT GAGE IN BRIDGE OR GUIDE HOLE, AND ALLOW IT TO FLOAT FREELY.

**NOTICE: DO NOT PRESS DOWN ON GAGE. FLOODING OR FLOAT DAMAGE COULD RESULT.**

- ⑥ OBSERVE AT EYE LEVEL THE MARK ON GAGE THAT LINES UP WITH TOP OF BRIDGE OR AIR HORN CASTING. SETTING SHOULD BE WITHIN  $\pm 1.588\text{mm}$  (1/16") OF SPECIFIED FLOAT LEVEL SETTING.

INCORRECT FUEL PRESSURE WILL ADVERSELY AFFECT FUEL LEVEL.

- ⑥ IF NECESSARY, REMOVE AIR HORN AND ADJUST FLOAT LEVEL TO SPECIFICATION.

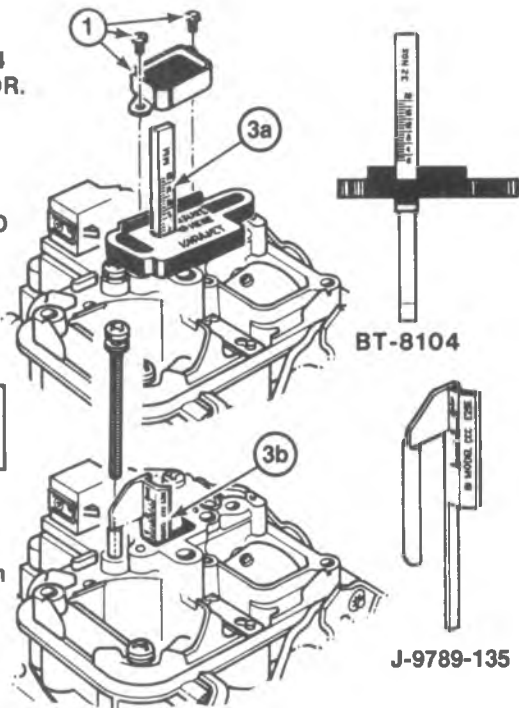
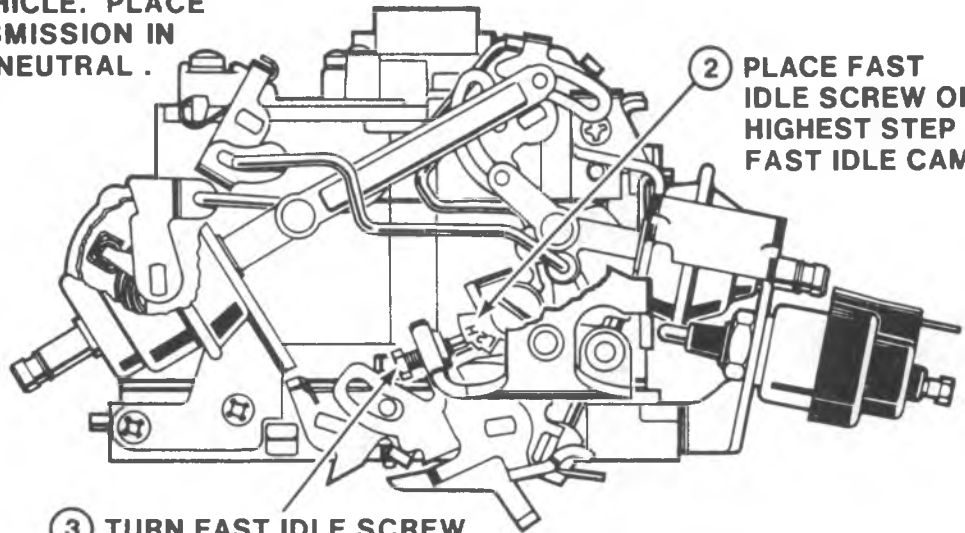

Fig. 6C3-8--External Float Check Procedure

- ① PREPARE VEHICLE FOR ADJUSTMENTS - SEE EMISSION LABEL ON VEHICLE. PLACE TRANSMISSION IN PARK/NEUTRAL .



- ② PLACE FAST IDLE SCREW ON HIGHEST STEP OF FAST IDLE CAM.

- ③ TURN FAST IDLE SCREW IN OR OUT TO OBTAIN SPECIFIED FAST IDLE R.P.M. - (SEE LABEL).

2B6C105

Fig. 6C3-9--Fast Idle Adjustment-On Vehicle

- ① PREPARE VEHICLE FOR ADJUSTMENTS - SEE EMISSION LABEL ON VEHICLE. NOTE: IGNITION TIMING SET PER LABEL

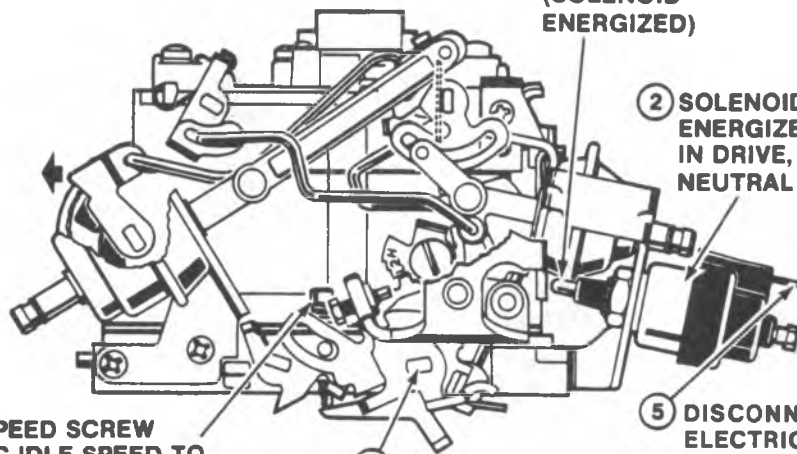

- ④ TURN SOLENOID SCREW TO ADJUST CURB IDLE SPEED TO SPECIFIED RPM (SOLENOID ENERGIZED)

- ② SOLENOID ENERGIZED - A/T IN DRIVE, M/T IN NEUTRAL

- ⑥ TURN IDLE SPEED SCREW TO SET BASIC IDLE SPEED TO SPECIFICATIONS. RECONNECT SOLENOID ELECTRICAL LEAD AFTER ADJUSTMENT

- ③ OPEN THROTTLE SLIGHTLY TO ALLOW SOLENOID PLUNGER TO FULLY EXTEND

- ⑤ DISCONNECT ELECTRICAL LEAD TO DE-ENERGIZE SOLENOID

2B6C107

Fig. 6C3-10--Idle Speed Adjustment-Without A/C

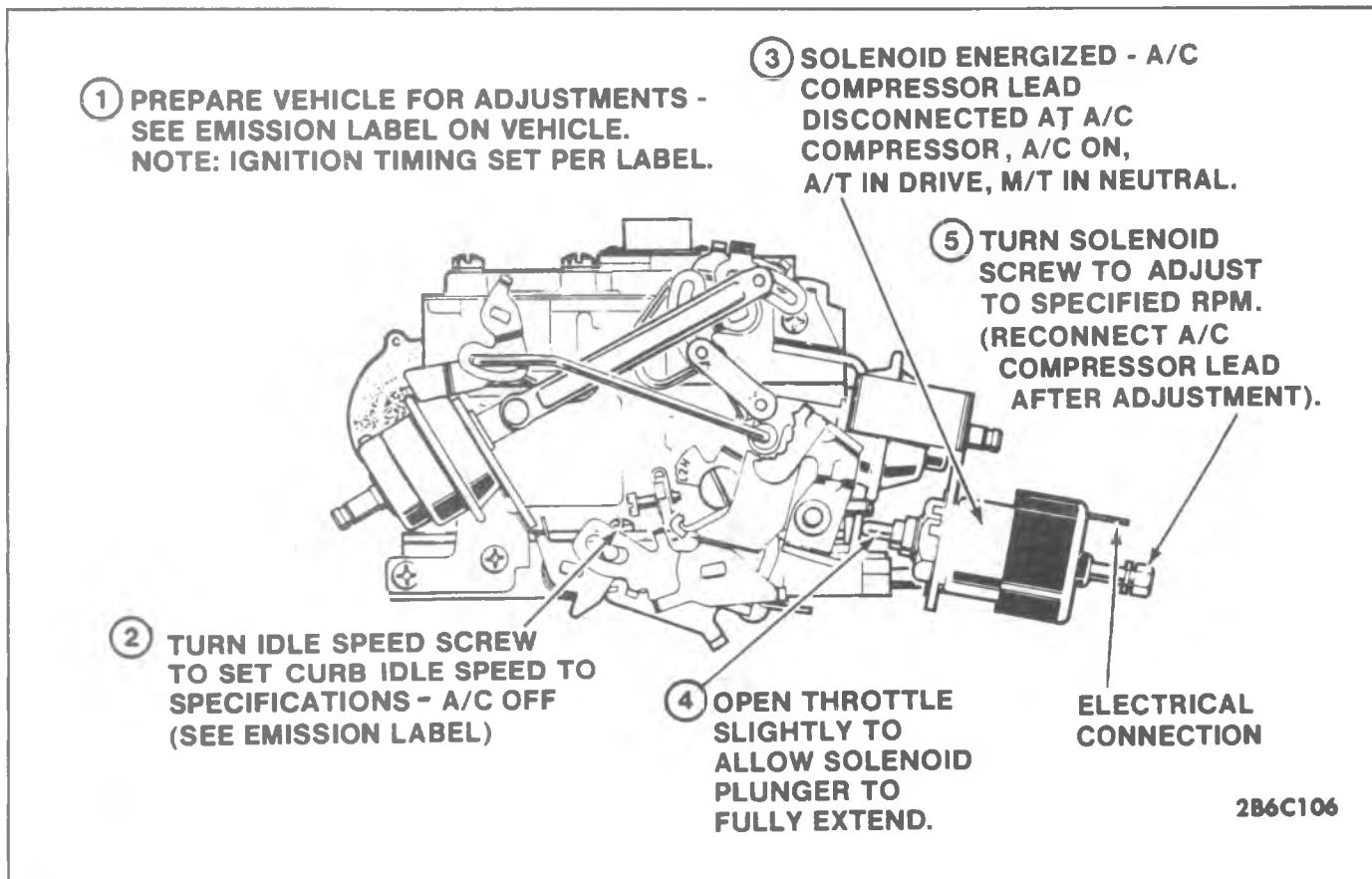

Fig. 6C3-11-Idle Speed Adjustment-With A/C

circuit in solenoid feed wire and repair.

#### Remove

1. Remove carburetor air cleaner.
2. Disconnect electrical connector at solenoid.
3. Remove large retaining nut, tabbed lock washer, and remove solenoid.

#### Install

1. Install solenoid and retaining nut, bending lock tabs against nut flats.
2. Connect electrical connector.
3. Install air cleaner.
4. Refer to Vehicle Emission Control Information label and adjust idle speed.

### THROTTLE POSITION SENSOR (TPS) ADJUSTMENT

The cup plug covering the TPS adjustment screw (Fig. 6C3-12) is used to provide a tamper-resistant design and retain the factory setting during vehicle operation. DO NOT REMOVE the plug unless, in diagnosis, the "System Performance Check" (Section 6E) indicates the TPS Sensor is not adjusted correctly or it is necessary to replace the air horn assembly, float bowl, TPS sensor, or TPS adjustment screw. This is a critical adjustment that must be performed accurately and carefully to ensure proper vehicle performance and control of emissions.

If necessary to adjust the TPS sensor, proceed as follows:

1. Using a .078" (5/64") drill, drill a hole in the steel cup plug covering the TPS adjustment screw. Use care in drilling to prevent damage to adjustment screw head.
2. Using a small slide hammer or equivalent, remove steel plug from air horn.
3. Disconnect the TPS connector and jumper all three terminals. (Jumpers can be made up using terminals 12014836 and 12014837). Make jumpers up with #16, #18 or #20 wire approximately 6" long.
4. Connect digital voltmeter (such as J-29125-A) from TPS connector center terminal (B) to bottom terminal (C).
5. With ignition on, engine stopped, turn the TPS screw with flat bladed screwdriver or equivalent to obtain .26 volts at curb idle throttle position with A/C OFF and ISC fully retracted.
6. After adjustment, a new cup plug (supplied in service kits) or silicone sealant RTV rubber or equivalent must be inserted in air horn. If cup plug is used, the cup should face outward and be flush with air horn casting.

### MIXTURE CONTROL SOLENOID REPLACEMENT

Refer to Section 6E1 for diagnosis of mixture control (M/C) solenoid.

1. Removing three(3) mixture control solenoid screws in air horn (Fig. 6C3-13), then using a slight twisting motion, carefully lift solenoid out of air horn. Remove and discard solenoid gasket.
2. Remove seal retainer and rubber seal from end of solenoid stem being careful not to damage or nick end

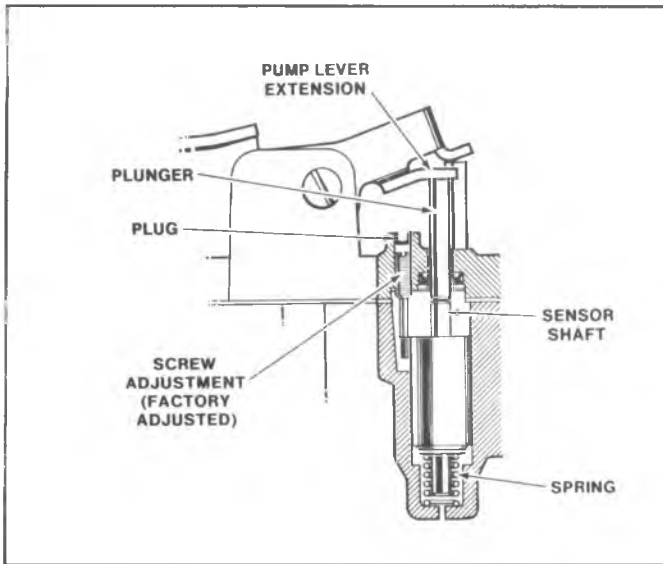

Fig. 6C3-12--Throttle Position Sensor

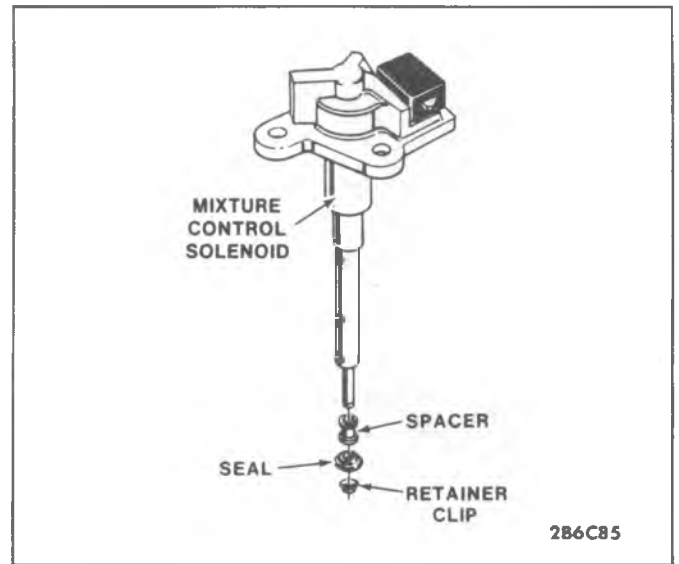

Fig. 6C3-14--Mixture Control Solenoid

- of solenoid stem (Fig. 6C3-14). Discard seal and retainer.
3. Install spacer and new rubber seal on mixture control solenoid stem making sure seal is up against the spacer. Then, using a 3/16" socket and light hammer, carefully drive retainer on stem. Drive retainer on stem only far enough to retain rubber seal on stem leaving a slight clearance between the retainer and seal to allow for seal expansion.
  4. Prior to installing a replacement mixture control solenoid, lightly coat the rubber seal on the end of the solenoid stem with a silicone grease or light engine oil.
  5. Using a new mounting gasket, install mixture control solenoid on air horn, carefully aligning solenoid stem with recess in bottom of bowl.
  6. Use a slight twisting motion of the solenoid during installation to ensure rubber seal on stem is guided into recess in the bottom of the bowl to prevent distortion or damage to the rubber seal. Install three(3) solenoid attaching screws and tighten securely.

7. Install Mixture Control Solenoid Connector, and check for proper latching. Latch may require filing, as shown in Figure 6C3-15.

Check colors of wires in connector for proper position (Fig. 6C3-15). Pink wire must be on right hand terminal of connector, as viewed from harness end. If incorrect, reverse two wires, using Tool J-28742 or equivalent.

**NOTICE:** The System Performance Check should be performed after any repairs to the Computer Command Control system have been made.

### IDLE MIXTURE ADJUSTMENT

The E2SE carburetor has been calibrated at the factory and should not normally need adjustment in the field. For this reason, the mixture adjustment should never be changed from the original factory setting. However, if during diagnosis, the "System Performance Check" (See Section 6E1) indicates the carburetor to be the cause of a Driver Performance Complaint or emissions failure or

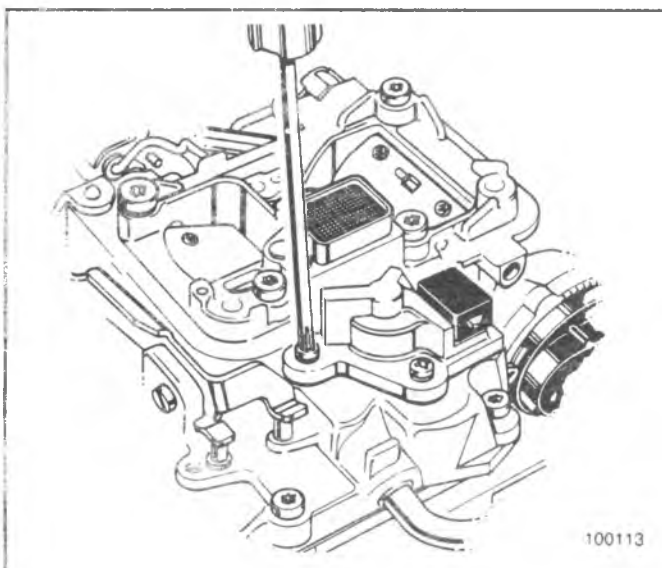

Fig. 6C3-13--M/C Solenoid Removal and Installation

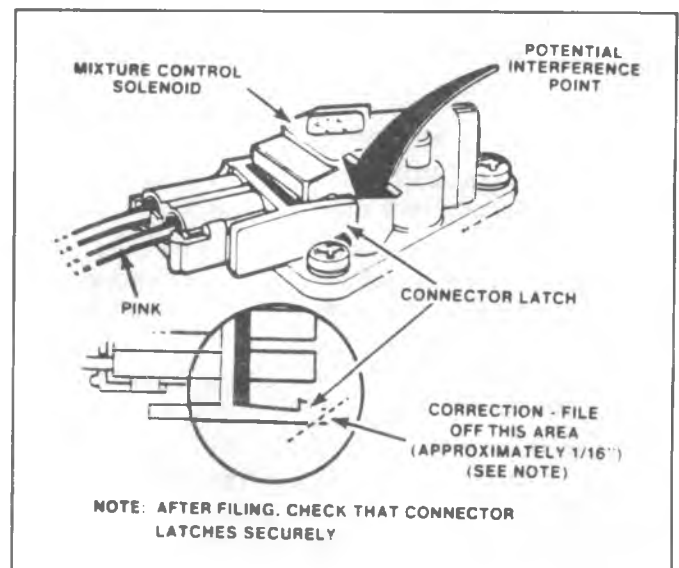

Fig. 6C3-15--Mixture Control Solenoid Connector

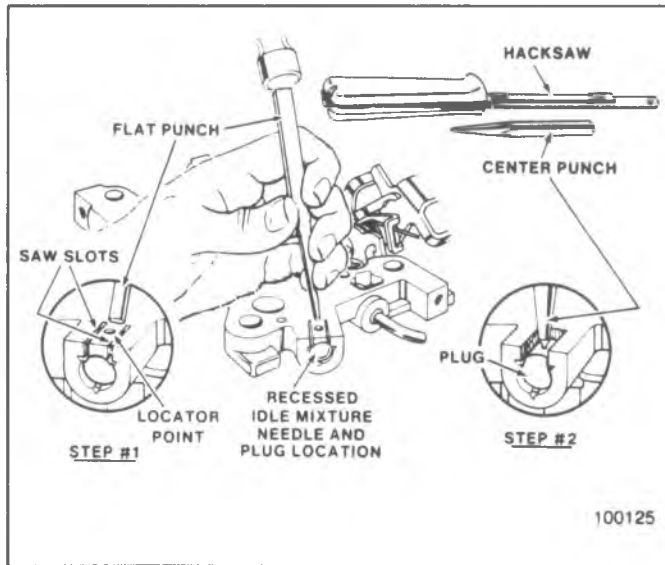

Fig. 6C3-16--Idle Mixture Needle Plug Removal

critical parts such as air horn, float bowl or throttle body are replaced, the carburetor can be adjusted using the following procedure. After adjustment, cover plugged areas with RTV rubber or equivalent.

### Carburetor Pre-Set Procedure

1. Remove carburetor from engine following normal service procedures to gain access to plug covering the idle mixture needle. Remove plug (Fig. 6C3-16) following procedure under Unit Repair (Throttle Body Disassembly). Turn mixture screw in until lightly seated and back out 4 turns.
2. If the plug in air horn covering idle air bleed has been removed (Fig. 6C3-20), replace air horn. If plug is still in place, do not remove plug.
3. Remove vent stack screen assembly (Fig. 6C3-20) to gain access to lean mixture screw. (Be sure to reinstall vent stack screen assembly after adjustment).
4. Turn lean mixture screw (Fig. 6C3-17) in until lightly bottomed and back out 2-1/2 turns. Some resistance should be felt. If no resistance, remove screw and check for spring.
5. Reinstall carburetor on engine:
  - a. Do not install air cleaner and gasket.
  - b. Disconnect the bowl vent line at carburetor.
  - c. Disconnect the EGR valve hose and canister purge hose at the carburetor and cap the carburetor ports.
  - d. Refer to Vehicle Emission Control Information label hose and observe hose from port "D" on carburetor to temperature sensor and secondary vacuum break TVS.  
Disconnect hose at temperature sensor on air cleaner and plug open hose.
  - e. Connect a dwell meter positive lead to the mixture control solenoid dwell test lead (green connector). Connect other lead on meter to ground. Set dwell meter to 6-cylinder position. Connect a tachometer to distributor lead (brown connector). (Tachometer

should be connected to the distributor side of the tach filter if vehicle is equipped with a tachometer).

- f. **BLOCK DRIVE WHEELS.**
  - g. Place transmission PARK (automatic transmission) or NEUTRAL (manual transmission) and set the parking brake.
6. Proceed to Mixture Adjustment Procedure.

### Mixture Adjustment Procedure

1. Pre-set carburetor following procedure above.
2. Run engine on high step of fast idle cam until engine cooling fan starts to cycle. (At least three minutes and until in closed loop.)
3. Run engine at 3,000 RPM and adjust the lean mixture screw (Fig. 6C3-17) slowly in small increments allowing time for dwell to stabilize after turning the screw to obtain an average dwell of 35°. If dwell is too low, back screw out; if too high, screw it in. If unable to adjust to specifications, inspect main metering circuit for leaks, restrictions, etc. (See Carburetor Unit Repair).

*The dwell reading of the M/C solenoid is used to determine calibration and is sensitive to changes in fuel mixture caused by heat, air leaks, etc. While idling, it is normal for the dwell to increase and decrease fairly constantly over a relatively narrow range, such as 5°. However, it may occasionally vary by as much as 10-15° momentarily due to temporary mixture changes. The dwell reading specified is the average of the most consistent variation. The engine must be allowed a few moments to stabilize at idle or 3,000 RPM as applicable before taking a dwell reading.*

4. Return to idle.
5. Adjust idle mixture screw (Fig. 6C3-17) to obtain an average dwell of 25° with cooling fan in off cycle. If reading is too low, back screw out. If too high, turn it in. Allow time for reading to stabilize after each adjustment. Adjustment is very sensitive. Make final check with adjusting tool removed.

If unable to adjust to specifications, inspect idle system for leaks, restrictions, etc. (See Carburetor Unit Repair).

6. Disconnect mixture control solenoid when cooling fan is in off cycle and check for an RPM change of at least 50 RPM. If RPM does not change enough, inspect idle air bleed circuit for restrictions, leaks, etc. (See Carburetor Unit Repair).
7. Run engine at 3,000 RPM for a few moments and note dwell reading. Dwell should be varying with an average reading of 35° (see Mixture Adjustment Specifications).

If not at 35° average dwell: Reset lean mixture screw per Step 3. Then reset idle mixture screw to obtain 25° dwell per Step 5.

If at 35° average dwell: Reconnect systems disconnected earlier (purge and vent hoses, EGR valve, etc.), reinstall vent screen and set idle speed(s) per Vehicle Emission Control Information Label on the vehicle. It is not necessary to repeat "Systems Performance Check" (Section 6E1) after proper adjustment of carburetor.

THESE ADJUSTMENTS SHOULD BE PERFORMED ONLY IF INDICATED BY SYSTEM PERFORMANCE CHECK.

**LEAN MIXTURE SCREW:**

- ① WITH VENT SCREEN (OR ENTIRE AIR HORN) OFF, USE TOOL J-28696-10 OR BT-7928 OR EQUIVALENT, TO LIGHTLY BOTTOM LEAN MIXTURE SCREW.
- ② BACK OUT NUMBER OF TURNS INDICATED IN SPECIFICATIONS.
- ③ REFER TO VEHICLE MANUFACTURER'S SERVICE MANUAL SECTION 6C FOR "LEAN MIXTURE ADJUSTMENT".

**IDLE MIXTURE SCREW:**

- ④ WITH IDLE MIXTURE SCREW PLUG REMOVED, USE TOOL J-29030 OR BT-7610B OR EQUIVALENT TO LIGHTLY BOTTOM SCREW.
- ⑤ BACK OUT NUMBER OF TURNS INDICATED IN SPECIFICATIONS.
- ⑥ REFER TO SERVICE MANUAL SECTION 6C FOR "IDLE MIXTURE ADJUSTMENT".

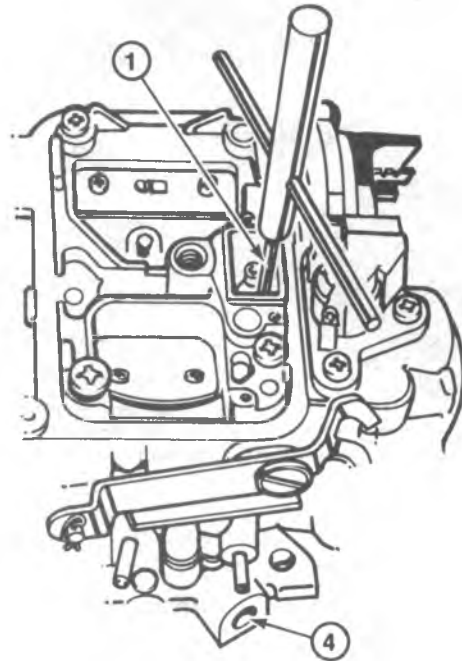

Fig. 6C3-17--Lean Mixture and Idle Mixture Screw Adjustments

## CARBURETOR REPLACEMENT (Fig. 6C3-18)

### Removal

Flooding, stumble on acceleration and other performance complaints are in many instances, caused by presence of dirt, water, or other foreign matter in carburetor. To aid in diagnosis, carburetor should be carefully removed from engine without draining fuel from bowl. Contents of fuel bowl may then be examined for contamination as carburetor is disassembled. Check fuel filter.

1. Remove air cleaner and gasket.
2. Disconnect fuel pipe and vacuum lines.
3. Disconnect electrical connectors.
5. Disconnect accelerator linkage.
6. If equipped with automatic transmission, disconnect downshift cable.
7. If equipped with cruise control, disconnect linkage.
8. Remove carburetor attaching bolts.
9. Remove carburetor and EFE heater/insulator.

### Installation

Fill carburetor bowl before installing carburetor. This reduces strain on starting motor and battery and reduces the possibility of backfiring while attempting to start engine. A small supply of no-lead fuel will enable carburetor to be filled and the operation of the float and inlet needle and seat to be checked. Operate throttle lever several times and check discharge from pump jets before installing carburetor.

1. Inspect EFE heater/insulator for damage. Be certain throttle body and EFE isolator surfaces are clean.
2. Install EFE heater/insulator.
3. Install carburetor and tighten nuts alternately to correct torque (See Carburetor Mounting Torque).
4. Connect downshift cable as required.
4. Connect cruise control cable as required.
6. Connect accelerator linkage.
7. Connect electrical connections.
8. Connect fuel pipe and vacuum hoses.
9. Check base (slow) and fast idle.
10. Install air cleaner.

### CARBURETOR MOUNTING TORQUE

When torquing carburetor after removal, overhaul, replacement or when installing a new EFE heater/insulator, torque mounting bolts, in a clockwise direction, to 18 N·m (160 in. lbs. 45 in. lbs.).

When retorquing carburetor at recommended maintenance intervals, check in a clockwise direction. If less than 9 N·m (80 in. lbs.), retorque to 13 N·m (110 in. lbs.); if greater than 9 N·m (80 in. lbs.).

### FUEL FILTER REPLACEMENT

A plugged fuel filter will restrict fuel flow into carburetor and will result in a loss of engine power.

1. Remove air cleaner.
2. Disconnect fuel line connection at inlet fuel

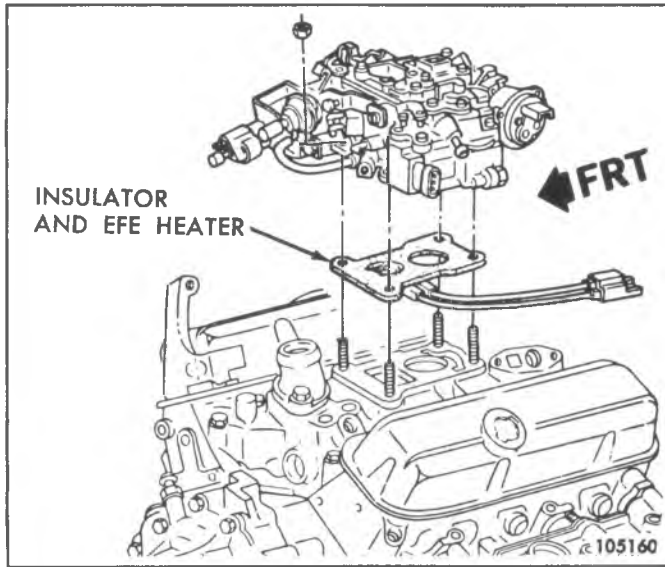

Fig. 6C3-18—Carburetor Replacement

filter nut.

3. Remove inlet fuel filter nut from carburetor.
4. Remove filter and spring (Figure 6C3-19).
5. Install spring and filter element in carburetor with hole in filter toward nut.
6. Install new gasket on inlet fitting nut and install nut in carburetor and tighten to 34 N·m (300 in. lbs.).
7. Install fuel line and tighten connector to 24 N·m (18 ft. lbs.) while holding fuel inlet fitting with wrench.
8. Run engine and observe for leaks.

### CHOKE AND HOSES

Check choke mechanism and vacuum break for proper operation at the recommended maintenance intervals. Any binding condition which may have developed due to petroleum gum formation on the choke shaft or from damage should be corrected. Check carburetor hoses for proper connection, cracking, abrasion or deterioration and correct or replace as necessary.

### CHOKE CHECK PROCEDURE

1. Remove air cleaner. With engine off, hold throttle half open. Open and close choke several times. Watch linkage to be certain all links are connected and there are no signs of damage.
2. If choke or linkage binds, sticks or works sluggishly, clean with Delco Choke Cleaner X-20-A or equivalent. Use cleaner as directed on can. If cleaning does not correct, replace binding parts.
3. Visually inspect carburetor to be certain all vacuum hoses are connected. Inspect hoses for cracks, abrasion, hardness or signs of deterioration. Replace or correct as necessary.
4. Make sure vacuum break diaphragm shafts are fully extended when engine is off. If shafts are not fully extended, replace vacuum break assembly. Start engine, primary vacuum break diaphragm shaft should fully retract. If unit fails to retract, replace vacuum break assembly.

### Checking Electric Choke

If the electric choke fails, the following checks should be made:

1. Check voltage at the choke heater connection with the engine running. If voltage is between 12 and 15 volts, replace the electric choke unit.
2. If the voltage is low or zero, check all wires and connections.
3. If steps 1 and 2 are OK, check the following:
  - Gage equipped vehicles - See Section 8A for Choke Heater Circuit Diagnosis.
  - Non-gage equipped vehicles - if the connection at the oil pressure switch is faulty, the temperature/pressure warning light will be off with the ignition key "on" and the engine not running. Repair wires as required. If choke is still inoperative, replace oil pressure switch.

### CHOKE COIL REPLACEMENT

1. Remove air cleaner and disconnect choke electrical connector.
2. Align a #21 drill (.159") on rivet head and drill only enough to remove rivet head (Fig. 6C3-27). After removing rivet heads and retainers, use a drift and small hammer to drive the remainder of the choke housing. Use care in drilling to prevent damage to the choke cover or housing. Remove the three retainers and choke cover assembly from choke housing.
3. Remove choke coil from housing.
4. Install the choke cover and coil assembly in choke housing as follows:

Install the choke cover and coil assembly in the choke housing, aligning notch in cover with raised casting projection on housing cover flange. Make sure coil pick-up tang engages the inside choke coil lever.

A choke cover retainer kit is required to attach the choke cover to the choke housing. Install proper retainers and rivets contained in kit using a suitable blind rivet installing tool.

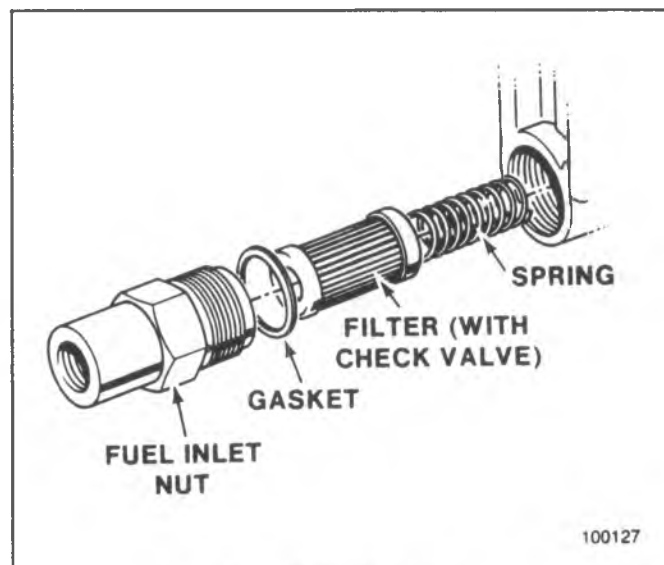

Fig. 6C3-19—Fuel Filter



5. Connect choke electrical connector.
6. Start engine, check operation of choke and then install air cleaner.

### SECONDARY VACUUM BREAK THERMAL VACUUM SWITCH (TVS)

The secondary vacuum break TVS, located in the air cleaner, improves cold starting and cold driveability by sensing carburetor air inlet temperature to control the carburetor secondary vacuum break.

#### Replacement

1. Remove air cleaner cover and element.
2. Disconnect vacuum hoses.
3. Pry clip from TVS and remove TVS.
4. Install new TVS and replace clip.
5. Reconnect vacuum hoses (refer to Vehicle Emission Control Information label).

6. Install air cleaner cover and element.

### SECONDARY VACUUM BREAK TVS CHECK

1. With engine at normal operating temperature, the Thermal Vacuum Switch (TVS) must be open (air cleaner cover on).
2. Apply either engine or auxiliary vacuum to the inlet port and check for vacuum at the outlet port (outlet port connects to secondary vacuum break).
3. If there is no vacuum, check thermostatic air cleaner vacuum hoses and/or replace the TVS.

### CARBURETOR ADJUSTMENTS

The remaining carburetor adjustments are part of Unit Repair. These adjustments, in most cases, may be performed on the vehicle. Refer to Figures 6C3-35 through 6C3-45 for adjustment procedures.

## UNIT REPAIR

In many cases, necessary service procedures can be performed without removing the carburetor from the engine. Adjustments of individual systems, for example, will be found in previous "On Vehicle Service" information.

The information that follows pertains to a complete overhaul of the carburetor, following removal from the engine. Complete overhaul includes: disassembly, thorough cleaning, inspection, and replacement of all gaskets, seals, worn or damaged parts, and adjustment of individual systems.

Refer to Figures 6C3-20 and 6C3-21 for identification of individual parts and for disassembly and assembly of carburetor components.

**NOTICE:** Before performing any service on the carburetor, it is essential that it be placed on a holding fixture, such as Tool J-9789-118A or BT-30-15. Without the use of the holding fixture, it is possible to damage throttle valves.

The primary and secondary throttle shafts, the secondary actuating lever and lockout lever, are coated with a special material to reduce friction and wear on these operating parts. Also, the secondary throttle bore and valve are coated with a special graphite compound for minimum air leakage past the valve for good idle air control. Care should be taken during carburetor service to not disturb or damage these coatings.

## DISASSEMBLY

### IDLE SPEED SOLENOID/PRIMARY VACUUM BREAK

#### Removal

1. Remove primary vacuum break hose.
2. Remove attaching screws holding the idle speed solenoid/primary vacuum break bracket to the carburetor.
3. Remove the bracket assembly. Disengage the vacuum break link ("T" pin) from the slot in the choke lever. Lift and rotate the bracket assembly to remove the air valve rod from the slot in the air valve lever.

**NOTICE:** Do not immerse the idle speed solenoid or vacuum break unit in any type of carburetor cleaner. These parts must always be removed before complete cleaning or overhaul, to avoid internal damage.

### SECONDARY VACUUM BREAK

#### Removal

Remove the attaching screws holding the vacuum break and bracket assembly to the throttle body. Rotate the assembly to disengage the vacuum break link ("T" pin) from the choke lever slot.

**NOTICE:** Do not immerse vacuum break unit in any type of carburetor cleaner. This part must always be removed before complete cleaning or overhaul, to avoid internal damage.

### AIR HORN

#### Removal

1. Remove the clip from the hole in the pump rod.
 

**NOTICE:** Do not remove pump lever retaining screw nor pump lever from the air horn assembly.
2. Remove and discard the retaining clip from the intermediate choke rod at the choke lever. A new clip is required for reassembly. Remove choke rod and the plastic bushing from the choke lever, (Fig. 6C3-22). Save for reassembly.
3. If a hot idle compensator valve is used, remove the two small attaching screws holding the valve to the air horn. Remove the valve and seal from the air horn. Discard the seal. The hot idle compensator valve must be removed to gain access to the short air horn-to-bowl attaching screw.
4. Remove three mixture control solenoid attaching screws from air horn. Use a slight twisting motion to lift the solenoid carefully from the air horn. Remove and discard solenoid gasket.
5. Remove seal retainer and rubber seal from the end of the solenoid stem, being careful to avoid damage to the end of the solenoid stem. Discard seal and retainer, (Fig. 6C3-23). Save spacer for reassembly.



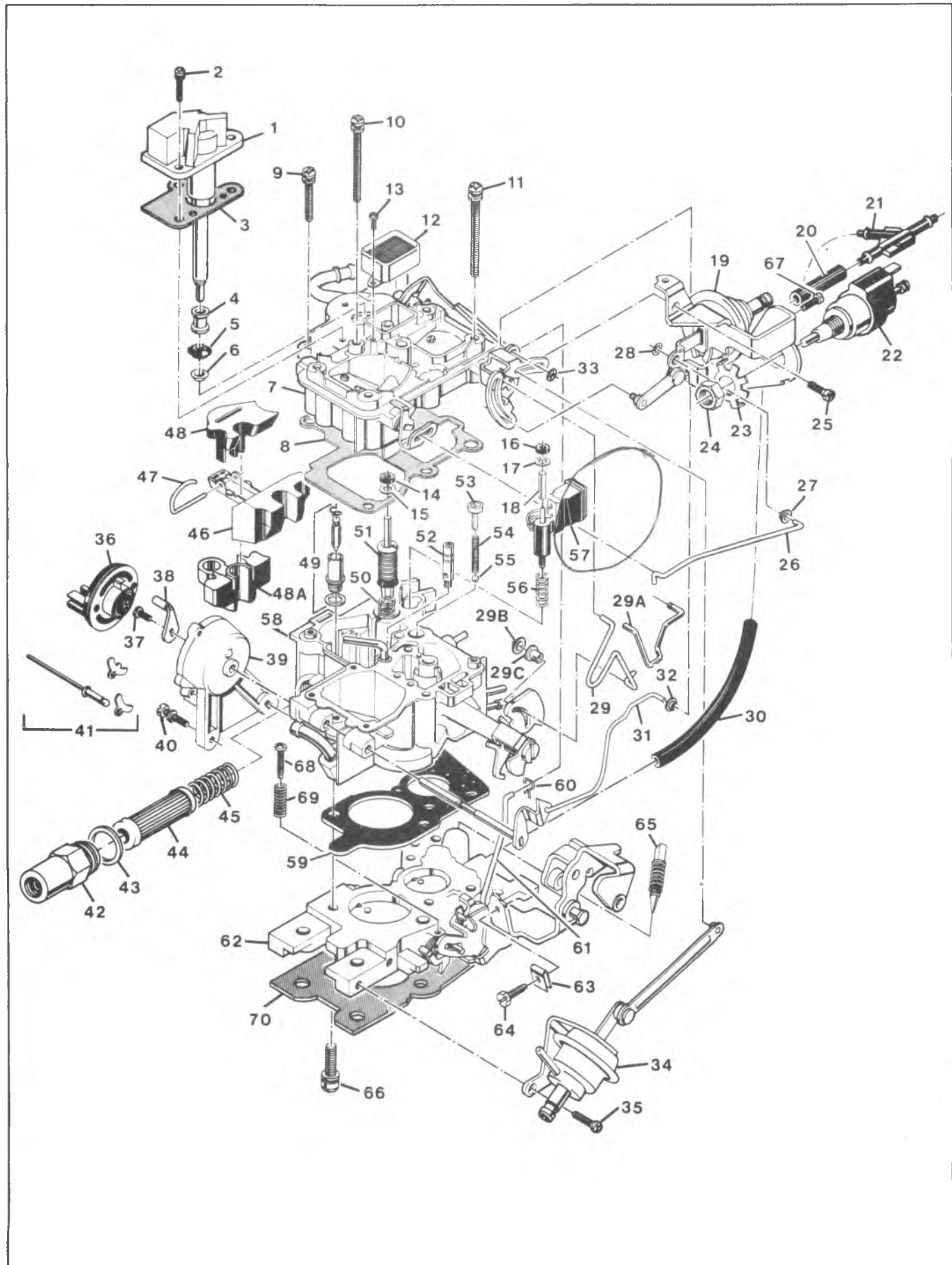

Fig. 6C3-20-E2SE Carburetor Assembly

## AIR HORN PARTS

1. MIXTURE CONTROL (M/C) SOLENOID
2. SCREW ASSEMBLY-SOLENOID ATTACHING
3. GASKET-M/C SOLENOID TO AIR HORN
4. SPACER-M/C SOLENOID
5. SEAL-M/C SOLENOID TO FLOAT BOWL
6. RETAINER-M/C SOLENOID SEAL
7. AIR HORN ASSEMBLY
8. GASKET-AIR HORN TO FLOAT BOWL
9. SCREW-AIR HORN TO FLOAT BOWL (SHORT)
10. SCREW-AIR HORN TO FLOAT BOWL (LONG)
11. SCREW-AIR HORN TO FLOAT BOWL (LARGE)
12. VENT STACK AND SCREEN ASSEMBLY
13. SCREW-VENT STACK ATTACHING
14. SEAL-PUMP STEM
15. RETAINER-PUMP STEM SEAL
16. SEAL-T.P.S. PLUNGER
17. RETAINER-T.P.S. PLUNGER SEAL
18. PLUNGER-T.P.S. ACTUATOR

## CHOKE PARTS

19. VACUUM BREAK AND BRACKET ASSEMBLY- PRIMARY
20. HOSE-VACUUM BREAK PRIMARY
21. TEE-VACUUM BREAK
22. SOLENOID-IDLE SPEED
23. RETAINER-IDLE SPEED SOLENOID
24. NUT-IDLE SPEED SOLENOID ATTACHING
25. SCREW-VACUUM BREAK BRACKET ATTACHING
26. LINK-AIR VALVE
27. BUSHING-AIR VALVE LINK
28. RETAINER-AIR VALVE LINK
29. LINK-FAST IDLE CAM
- 29A LINK-FAST IDLE CAM
- 29B RETAINER-LINK
- 29C BUSHING-LINK
30. HOSE-VACUUM BREAK
31. INTERMEDIATE CHOKE SHAFT/LEVER/LINK ASSEMBLY
32. BUSHING-INTERMEDIATE CHOKE LINK
33. RETAINER-INTERMEDIATE CHOKE LINK
34. VACUUM BREAK AND LINK ASSEMBLY-SECONDARY
35. SCREW-VACUUM BREAK ATTACHING
36. ELECTRIC CHOKE-COVER AND COIL ASSEMBLY
37. SCREW-CHOKE LEVER ATTACHING
38. CHOKE COIL LEVER ASSEMBLY
39. CHOKE HOUSING
40. SCREW-CHOKE HOUSING ATTACHING
41. CHOKE COVER RETAINER KIT
67. SCREW-VACUUM BREAK BRACKET ATTACHING

## FLOAT BOWL PARTS

42. NUT-FUEL INLET
43. GASKET-FUEL INLET NUT
44. FILTER-FUEL INLET
45. SPRING-FUEL FILTER
46. FLOAT AND LEVER ASSEMBLY
47. HINGE PIN-FLOAT
48. UPPER INSERT-FLOAT BOWL
- 48A LOWER INSERT-FLOAT BOWL
49. NEEDLE AND SEAT ASSEMBLY
50. SPRING-PUMP RETURN
51. PUMP PLUNGER ASSEMBLY
52. PRIMARY METERING JET ASSEMBLY
53. RETAINER-PUMP DISCHARGE BALL
54. SPRING-PUMP DISCHARGE
55. BALL-PUMP DISCHARGE
56. SPRING-T.P.S. ADJUSTING
57. SENSOR-THROTTLE POSITION (TPS)
58. FLOAT BOWL ASSEMBLY
59. GASKET-FLOAT BOWL

## THROTTLE BODY PARTS

60. RETAINER-PUMP LINK
61. LINK-PUMP
62. THROTTLE BODY ASSEMBLY
63. CLIP-CAM SCREW
64. SCREW-FAST IDLE CAM
65. IDLE NEEDLE AND SPRING ASSEMBLY
66. SCREW-THROTTLE BODY TO FLOAT BOWL
68. SCREW-IDLE STOP
69. SPRING-IDLE STOP SCREW
70. GASKET-INSULATOR FLANGE

104823

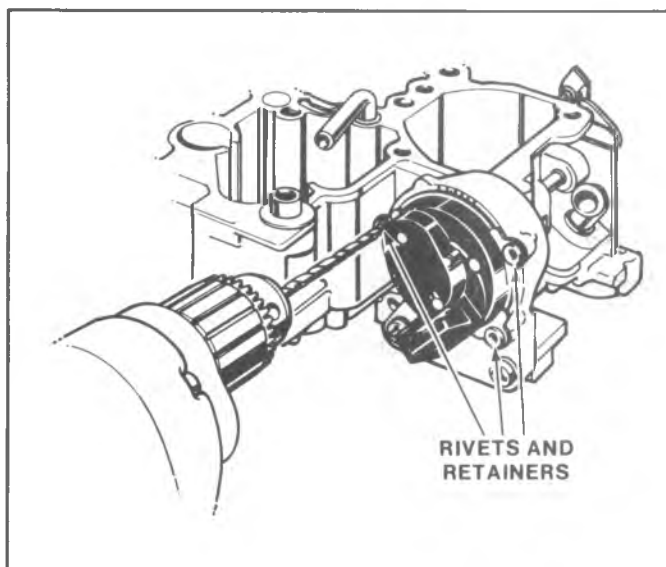

Fig. 6C3-27--Choke Cover Removal

### Disassembly

1. Place throttle body assembly on suitable carburetor holding fixture to avoid damage to throttle valves.
2. Hold primary throttle lever in wide open position, and remove pump rod from throttle lever after rotating rod until "squirt" on rod aligns with slot in lever. Further disassembly of the throttle body is not required for cleaning purposes.

**NOTICE:** The primary and secondary throttle valve screws are staked in place and should not be removed. The throttle body is serviced as a complete assembly.

3. **DO NOT** remove the plug covering the idle mixture needle unless normal soaking in cleaner and blowing with shop air fails to clean the idle mixture passages, or unless the Computer Command Control System Performance Check (Refer to "On Vehicle Service" section and Section 6E1) indicates that adjustment is required. If necessary, remove the idle mixture plug and needle (Fig. 6C3-28) as follows:
  - a. Invert throttle body and place on suitable holding fixture, (manifold side up).
  - b. Make two parallel cuts in the throttle body, one on each side of the locator point, with a hacksaw. Cuts should reach down to the steel plug, but should not extend more than 1/8" (3.2mm) beyond the locator point. Distance between saw cuts depends on the size of the punch to be used.
  - c. Place a flat punch at a point near the ends of the saw marks in the throttle body. Hold the punch at a 45° angle, and drive it into the throttle body until the casting breaks away, exposing the steel plug.
  - d. Hold center punch in vertical position, and drive it into the plug. Now hold punch at a 45° angle, and drive punch out of the casting.

**NOTICE:** Hardened plug will break, rather than remaining intact. It is not necessary to remove the plug completely, but remove loose pieces to allow use of idle

mixture adjusting tool (J-29030, BT-7610B or equivalent).

- e. Use idle mixture adjusting tool to remove idle mixture needle and spring from the throttle body.

### CLEANING AND INSPECTION

Metal carburetor parts should be cleaned in a cold immersion-type cleaner such as Carbon X (X-55) or equivalent.

**NOTICE:** Idle speed solenoid, mixture control solenoid, throttle position sensor, electric choke, rubber and plastic parts, diaphragms, pump plunger, and plastic filler block **SHOULD NOT BE IMMERSSED** in carburetor cleaner as they will harden, swell or distort.

The plastic bushing in the throttle lever will withstand normal cleaning in carburetor cleaner.

1. Thoroughly clean all metal parts and blow dry with shop air. Make sure that all fuel passages and metering parts are free of burrs and dirt. Do not pass drills or wires through jets and passages.
2. Inspect upper and lower surfaces of carburetor castings for damage.
3. Inspect holes in levers for excessive wear or out-of-round conditions. If worn, levers should be replaced. Inspect plastic bushings in levers for damage and excessive wear. Replace as required.
4. Check, repair, or replace parts if the following problems are encountered and when the carburetor is believed to be the only cause:

#### ● FLOODING

1. Inspect float valve seat for dirt, deeply worn grooves, scoring and improper sealing.
2. Inspect float valve pull clip and, if used, the float stabilizing spring, for improper installation. Be careful not to bend pull clip or spring.
3. Inspect float, float arms and hinge pin for distortion, binds, and burrs. Check density of material in the float, and if heavier than normal, replace the float.
4. Replace fuel inlet filter.

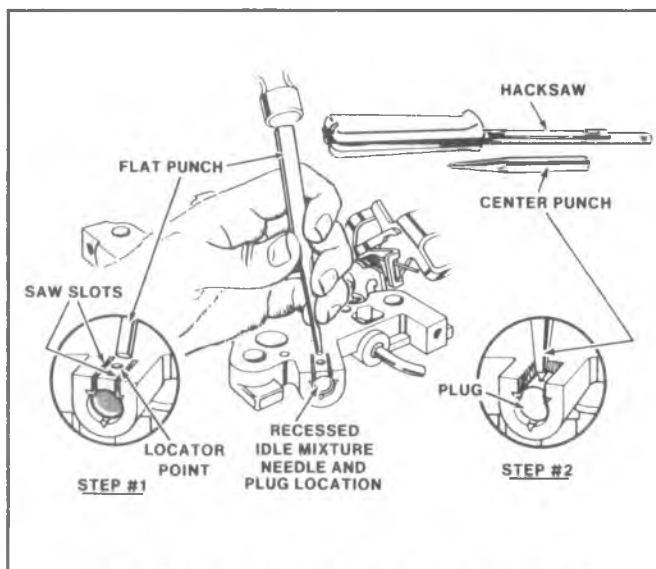

Fig. 6C3-28--Idle Mixture Needle Plug Removal

### ● HESITATION

1. Inspect pump plunger for cracks, scores and excessive cup wear. A used pump cup will shrink when dry. If dried out, soak in fuel for 8 hours before testing.
2. Inspect pump duration spring and return spring for weakness and distortion.
3. Check pump passages and jet for dirt, improper seating of discharge check ball or thermostatically controlled bypass valve, and sorting in the pump well. Check condition of pump discharge check ball spring, and replace if necessary.
4. Check pump linkage for excessive wear, and repair or replace if necessary.

### ● HARD STARTING - POOR COLD OPERATION

1. Check choke valve and linkage for excessive wear, binds or distortion.
2. Test vacuum break diaphragm(s) for leaks.
3. Replace fuel filter.
4. Inspect float valve for sticking, dirt, etc.
5. Also check items under "Flooding".

### ● POOR PERFORMANCE - POOR GAS MILEAGE

1. Clean all fuel and vacuum passages in castings.
2. Check choke valve for restriction of movement.
3. Inspect metering jet for dirt, loose parts, or damage.

**NOTICE:** DO NOT attempt to readjust the mixture screw located inside the metering jet. It is factory adjusted, and readjustment will change fuel system calibration. NO ATTEMPT should be made to change this adjustment UNLESS indicated as the result of a Computer Command Control System Performance Check. (Refer to "On-Vehicle Service" section, Section 6E1).

4. Check air valve and secondary metering rod for binding conditions. If air valve or metering rod is damaged, or if metering rod adjustment is changed from the factory setting, the air horn assembly must be replaced. Also check air valve lever spring for improper installation, (tension against air valve shaft pin).

### ● ROUGH IDLE

1. Inspect gasket and gasket mating surfaces on castings for nicks, burrs and damage to sealing beads.
2. Clean all idle fuel passages.
3. If removed, inspect idle mixture needle for ridges, burrs, and bends.
4. Check throttle lever and valves for binds, nicks and other damage.
5. Check all diaphragms for ruptures and leaks.

## ASSEMBLY

### THROTTLE BODY

#### Assembly

1. Hold primary throttle lever wide open. Install lower end of pump rod in throttle lever, after aligning

"squirt" on rod with slot in lever. End of rod should point outward toward the throttle lever.

2. If removed, install idle mixture needle and spring, using tool J-29030, BT-7610B or equivalent. Lightly bottom needle, then back it out four turns as a preliminary idle mixture adjustment. Final idle mixture adjustment must be made on vehicle. Refer to "On Vehicle Service" Section for this procedure.

### FLOAT BOWL

#### Assembly

If a new float bowl assembly is used, stamp or engrave the model number on the new float bowl at location indicated in Figure 6C3-7.

1. Install new throttle body-to-bowl gasket over two locating dowels on bowl.
2. Rotate fast idle cam so that steps face fast idle screw on throttle lever when properly installed. Install throttle body, making sure the throttle body is located properly over the dowels on the float bowl. Install four throttle body-to-bowl screws and lockwashers, tighten evenly and securely. Inspect linkage to insure the lockout tang is located properly to engage slot in the secondary lever, and that the linkage moves freely and does not bind.
3. Place carburetor on suitable holding fixture.
4. Install fuel inlet filter spring, new filter assembly, new gasket and inlet nut. Torque nut to 24 N·m (18 ft. lbs.). Be sure filter is the type that includes a check valve, to meet motor vehicle safety standards. When properly installed, hole in filter (check valve end) faces the inlet nut.

**NOTICE:** Tightening beyond specified torque can damage nylon gasket, causing a fuel leak.

5. Install choke housing on throttle body, making sure the raised boss and locating lug at rear of housing fit into recesses in float bowl casting. Install choke housing attaching screws and lockwashers, and tighten screws evenly and securely.
6. Install intermediate choke shaft assembly in float bowl by pushing shaft through from the throttle lever side (Fig. 6C3-29).
7. With intermediate choke lever in the UP or 12 o'clock position, install choke coil lever (inside choke housing) on flat surface of intermediate choke shaft. Choke coil lever is properly aligned when the coil pick-up tang is in the UP position. Install choke coil lever retaining screw into end of intermediate choke shaft and tighten securely.
8. Install pump discharge check ball, spring and new plastic retainer in float bowl. Tap lightly in place until top of retainer is flush with bowl casting surface.
9. Use a wide-blade screwdriver to install float valve seat (with gasket) and the metering jet. Tighten securely. If used, insert lower plastic filler block.
10. To make adjustment easier, carefully bend float arm upward at notch in float arm before assembly.
11. Install float valve onto float arm by sliding float lever under pull clip. Correctly install pull clip by hooking the flip over the edge of the float, on the float arm facing the float pontoon, (Fig. 6C3-30). If used, the float stabilizing spring should be assembled as shown in

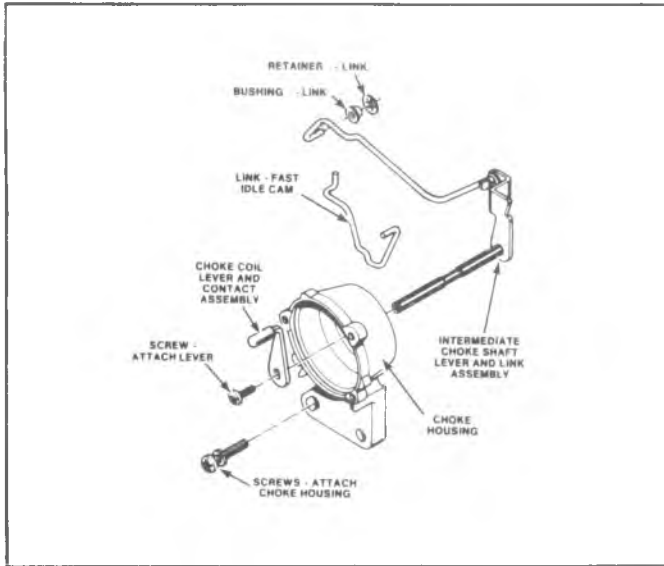

Fig. 6C3-29--Choke Assembly

Figure 6C3-31.

12. Install float hinge pin into float arm, with end of loop of pin facing the pump well. Install float assembly by aligning valve in the seat and float hinge pin into locating channels in the float bowl.
13. Adjust float level following adjustment procedure in Figure 6C3-35. See Adjustment chart for specification at end of this section.
14. Install upper plastic filler block over float valve, pressing downward until it is properly seated, flush with bowl casting surface.
15. If, prior to disassembly, the Computer Command Control system Performance Check indicated incorrect adjustment, use tool J-28696-10, BT-7928, or equivalent, to bottom lightly the lean mixture screw, then back it out 2-1/2 turns, as a preliminary adjustment. Final lean mixture screw adjustment must be made on-vehicle. Refer to "On-Vehicle Service" section, for lean mixture screw (Fig. 6C3-17) adjustment procedures which is part of Idle Mixture Adjustment.

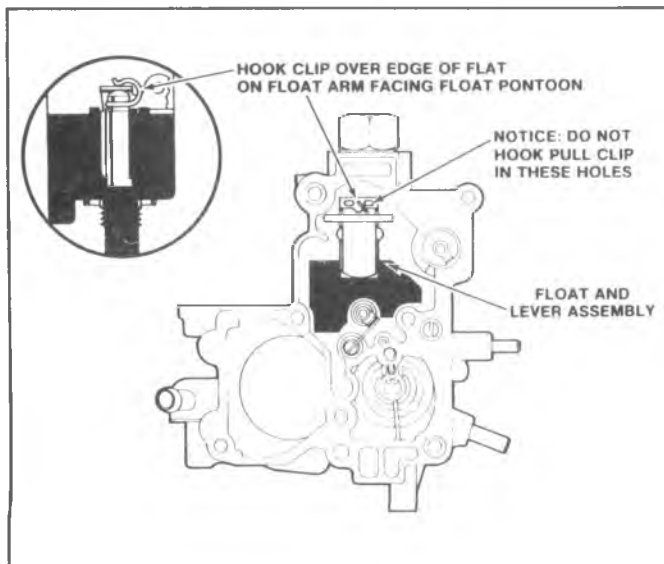

Fig. 6C3-30--Float Needle Pull Clip Location

16. Install Throttle Position Sensor (TPS) return spring in bottom of well in float bowl.
17. Install TPS and connector assembly in float bowl, aligning groove in electrical connector with "V" in float bowl casting. Push down on connector and sensor assembly so that connector wires and sensor are located below the bowl casting surface.

**NOTICE:** Care must be taken during installation of TPS to insure that the wires between connector and sensor assembly are not pinched and insulation is not broken. Accidental grounding of the TPS must be avoided.

18. Install air horn gasket on float bowl, locating gasket over two dowel locating pins on bowl.
19. Install pump return spring in pump well. Install pump plunger assembly in pump well.

## AIR HORN

### Assembly

1. Install new pump plunger steam seal and retainer in air horn casting. Stake seal retainer lightly in three places, choosing different locations than the original stakings.
2. Install new TPS actuator plunger seal and retainer in air horn casting. Stake seal retainer lightly in three places, choosing different locations than the original stakings.
3. Install vent screen assembly by installing two small attaching screws. Tighten securely.
4. Inspect the air valve shaft pin for lubrication, apply a liberal quantity of lithium base grease to the air valve shaft pin, especially at the area contacted by the windup spring.
5. Install fast idle cam rod in lower hole of choke lever, aligning "squirt" on rod with small slot in lever.
6. Install TPS plunger through seal in air horn until about half of the plunger extends above the surface of the air horn casting. Seal pressure should hold plunger in place during installation of air horn to float bowl.

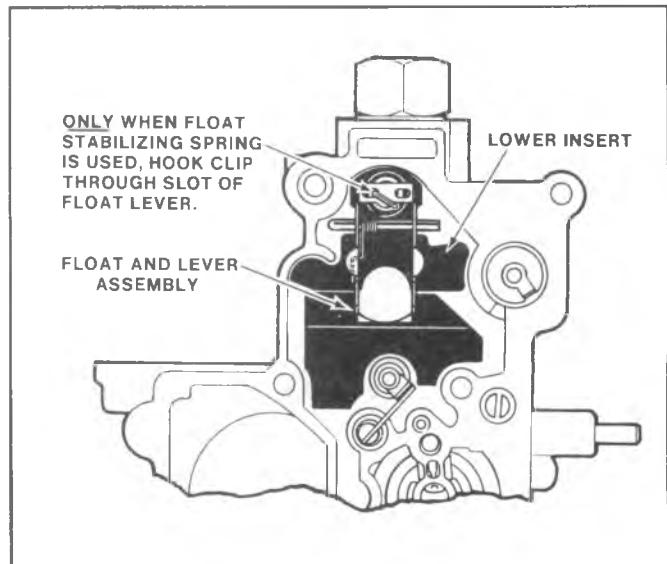

Fig. 6C3-31--Float Stabilizing Spring

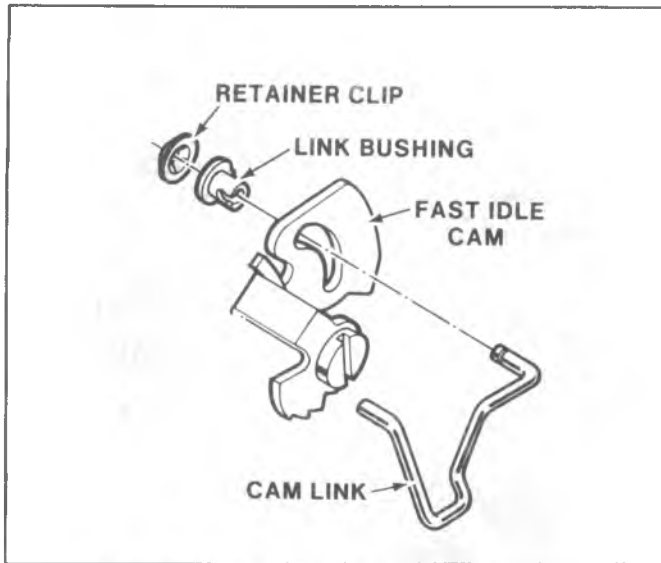

Fig. 6C3-32--Fast Idle Cam and Rod Assembly

### AIR HORN TO FLOAT BOWL

#### Installation

1. Rotate fast idle cam to its highest position. Tilt the air horn assembly to engage lower end of fast idle cam rod in slot of fast idle cam, and through the seal in the air horn casting.

In some models, the fast idle cam rod is assembled to the fast idle cam with a plastic bushing and retainer. This allows the air horn to be assembled to the float bowl before installing the rod to the cam. Where used, assemble the fast idle cam rod in the slot of the fast idle cam. Install new plastic bushing and retaining clip to the rod, making sure that the large end of the bushing faces the retaining clip when installed, (fig. 6C3-32).

**NOTICE:** Do not force air horn assembly onto bowl, but lower it into place gently. Be sure TPS actuator plunger engages the sensor plunger in bowl, by checking plunger movement.

2. Install air horn-to-bowl attaching screws and lockwashers, and tighten evenly and securely, (Fig. 6C3-33).
3. Install new retainer clip through hole in end of pump rod, extending through the pump lever, making sure clip is securely locked in place.
4. Install new seal in the recess of the air horn. Install hot idle compensator valve (if used) and retain with two small attaching screws. Tighten screws securely.
5. Install spacer and new rubber seal on mixture control solenoid stem, being sure seal is against the spacer. Use 5mm (3/16") socket with a light hammer to drive a new retainer on the stem carefully, (Fig. 6C3-23). Drive retainer on stem only far enough to retain rubber seal on stem, leaving a slight clearance between the retainer and seal to allow for seal expansion.
6. Coat the rubber seal, on the end of the mixture control solenoid stem, lightly with automatic transmission fluid. Use a new mounting gasket to install mixture

control solenoid on air horn, aligning the solenoid stem carefully with recess in bottom of bowl. A slight twisting motion of the solenoid during installation will help guide the rubber seal on the stem into the recess, preventing distortion or damage to the rubber seal. Install solenoid attaching screws and tighten securely.

7. Install plastic bushing in the hole in the choke lever, making sure small end of the bushing faces the retaining clip when installed, (Fig. 6C3-22). With choke coil lever and intermediate choke lever at the 12 o'clock position, install intermediate choke rod in the bushing. Retain rod with new clip, pressing clip securely in place with needle nose pliers. Be sure clip has full contact with rod, but that it is not seated tightly against bushing. Clearance between rod and bushing should be 0.8mm (.030").
8. Install secondary vacuum break assembly. Rotate assembly, and start end ("T" pin) of vacuum break link into the upper slot of the choke lever. Attach bracket to throttle body with countersunk screws. Tighten screws securely.
9. If air valve rod was removed from the primary side vacuum break plunger, install plastic bushing in hole of primary side vacuum break plunger, being sure that the small end of the bushing faces the retaining clip when installed. Insert end of air valve rod through bushing. Retain with new clip, pressing clip into place using needle nose pliers. Make sure clip has full contact with rod, but that it is not seated tightly against the bushing. Clearance between the rod and the bushing should be 0.8mm (.030").
10. Rotate primary side vacuum break assembly and insert end of air valve rod into the slot of air valve lever and end ("T" pin) of vacuum break link into the lower slot of the choke lever. Connect primary vacuum break hose to the tube on the throttle body and the tube on the vacuum break unit. Position bracket over the locating lug on the air horn and install with two countersunk screws in air horn and one screw, with lock washer, in the throttle body. Tighten screws securely.

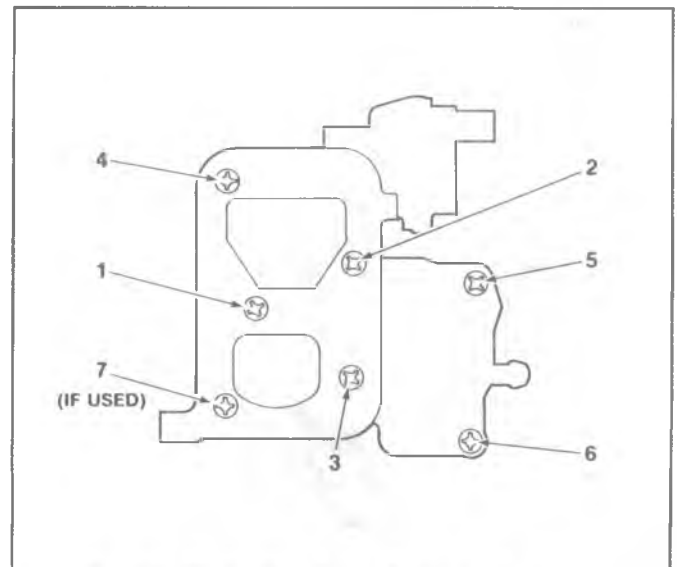

Fig. 6C3-33--Air Horn Screw Tightening Sequence

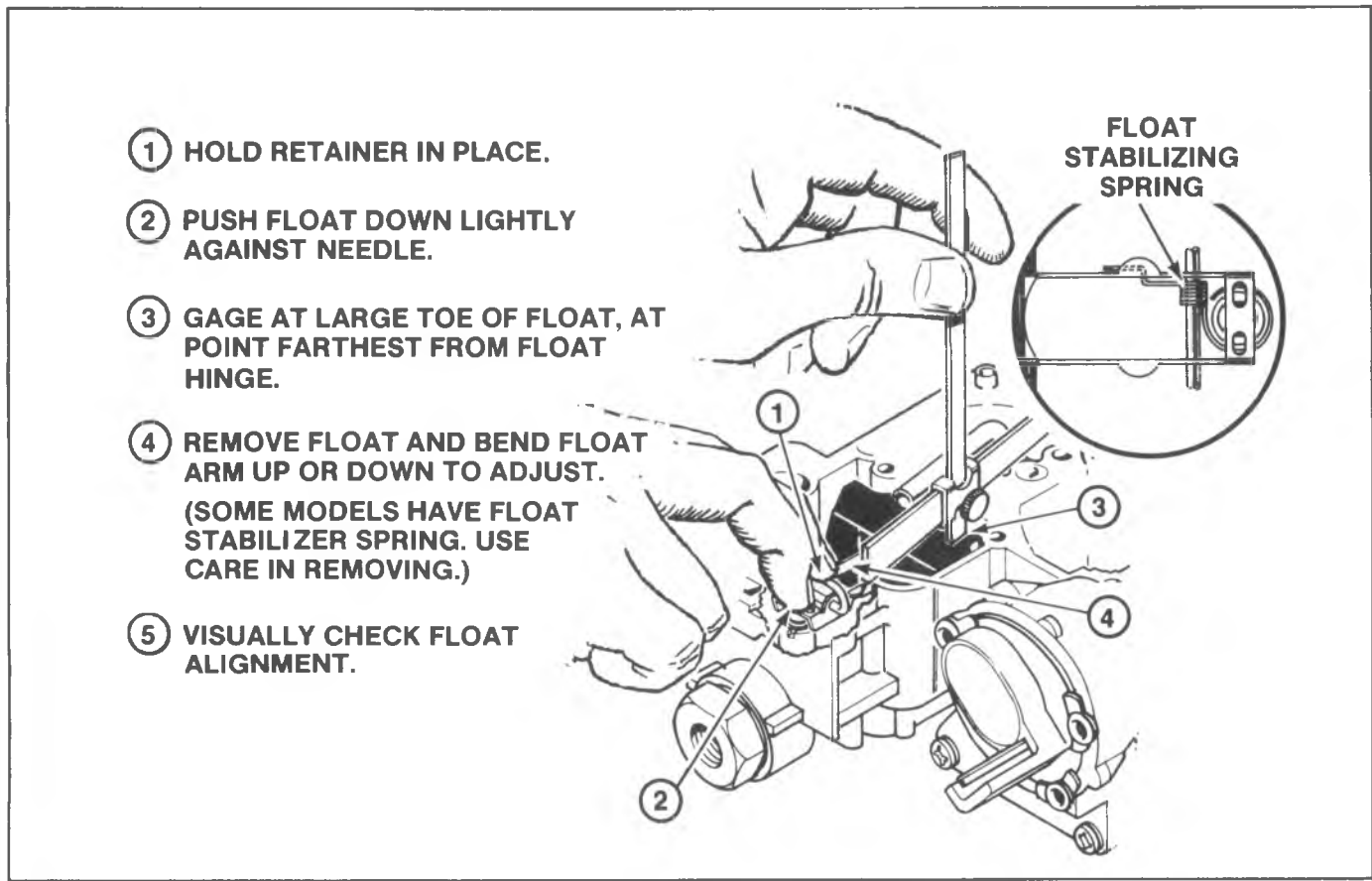

Fig. 6C3-35--Float Adjustment

11. Perform the two adjustments indicated below, which will be found in the carburetor adjustment section:  
**Air Valve Spring Adjustment**, Figure 6C3-36  
**Choke Coil Lever Adjustment**, Figure 6C3-37
12. Use a choke cover retainer kit for installing the choke cover and coil assembly in the choke housing, aligning the notch in the cover with the casting projection on the housing cover flange. Where a thermostatic coil with a "trapped" (box-shaped)

pick-up tang is used, be sure that the "trap" (box) surrounds the choke coil lever inside the choke housing, (Fig. 6C3-34).

Install proper retainers and rivets contained in the kit, using a suitable riveting tool.

**NOTICE:** DO NOT install a Choke Cover Gasket in the choke housing, as such installation would prevent grounding of the electrically heated choke element.

## ADJUSTMENTS

The carburetor adjustments that are part of Unit Repair, in most cases, may be performed on the vehicle.

The following adjustment procedures are arranged in a logical sequence for obtaining good results.

- Float Adjustment (Fig. 6C3-35)
- Air Valve Spring Adjustment (Fig. 6C3-36)
- Choke Coil Lever Adjustment (Fig. 6C3-37)
- Choke Angle Gage (Fig. 6C3-38)
- Vacuum Break Adjustment Information (Fig. 6C3-39)
- Choke Rod Fast Idle Cam Adjustment (Fig. 6C3-40)
- Primary Vacuum Break Adjustment (Fig. 6C3-41)
- Air Valve Rod Adjustment (Fig. 6C3-42)
- Secondary Vacuum Break Adjustment (Fig. 6C3-43)
- Unloader Adjustment (Fig. 6C3-44)
- Secondary Lockout Adjustment (Fig. 6C3-45)

Refer to **ON-VEHICLE SERVICE** for additional carburetor adjustments performed on the vehicle.

Refer to the end of this section for special tools.

Refer to the end of this section for carburetor specifications.

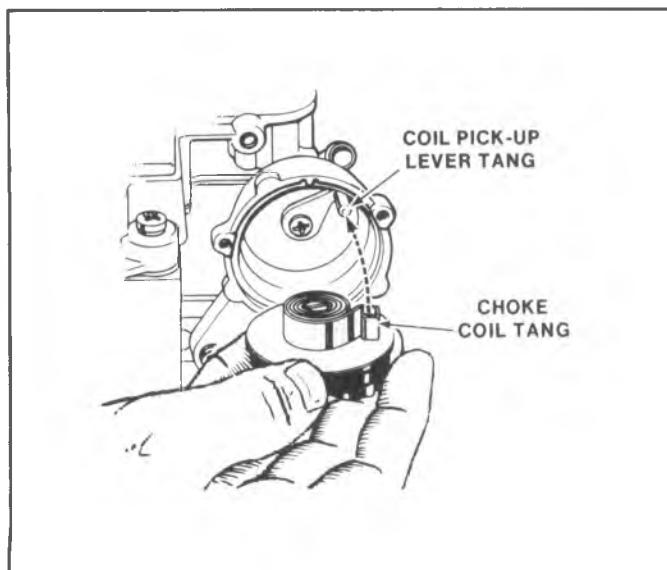

Fig. 6C3-34--"Trapped Stat" Choke Cover Installation



- ① IF NECESSARY, REMOVE INTERMEDIATE CHOKE ROD, TO GAIN ACCESS TO LOCK SCREW.
- ② LOOSEN LOCK SCREW USING 3/32" (2.381mm) HEX WRENCH.
- ③ TURN TENSION-ADJUSTING SCREW CLOCKWISE UNTIL AIR VALVE OPENS SLIGHTLY.  
TURN ADJUSTING SCREW COUNTER-CLOCKWISE UNTIL AIR VALVE JUST CLOSURES. CONTINUE COUNTER-CLOCKWISE SPECIFIED NUMBER OF TURNS.
- ④ TIGHTEN LOCK SCREW.
- ⑤ APPLY LITHIUM BASE GREASE TO LUBRICATE PIN AND SPRING CONTACT AREA.

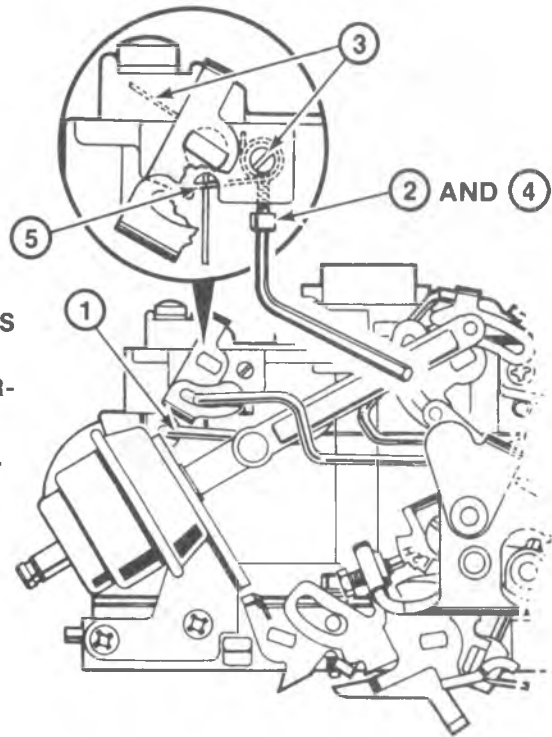

Fig. 6C3-36--Air Valve Spring Adjustment

- ① IF RIVETED, DRILL OUT AND REMOVE RIVETS. REMOVE CHOKE COVER AND COIL ASSEMBLY.
- ② PLACE FAST IDLE SCREW ON HIGH STEP OF FAST IDLE CAM.
- ③ PUSH ON INTERMEDIATE CHOKE LEVER UNTIL CHOKE VALVE IS CLOSED.
- ④ INSERT .085" (2.18mm) PLUG GAGE IN HOLE.
- ⑤ EDGE OF LEVER SHOULD JUST CONTACT SIDE OF GAGE.
- ⑥ SUPPORT AT "S" AND BEND INTERMEDIATE CHOKE ROD TO ADJUST.

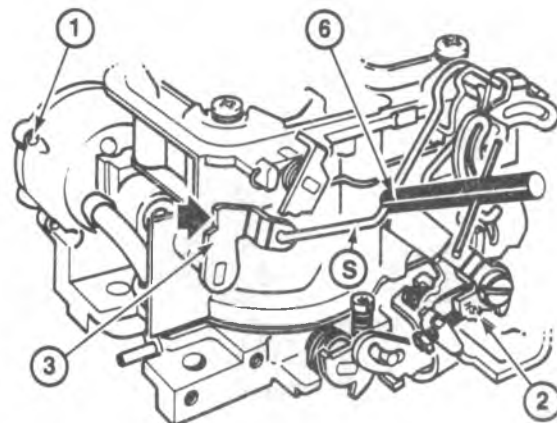
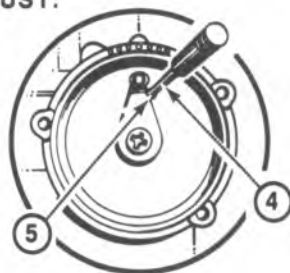

Fig. 6C3-37--Choke Coil Lever Adjustment



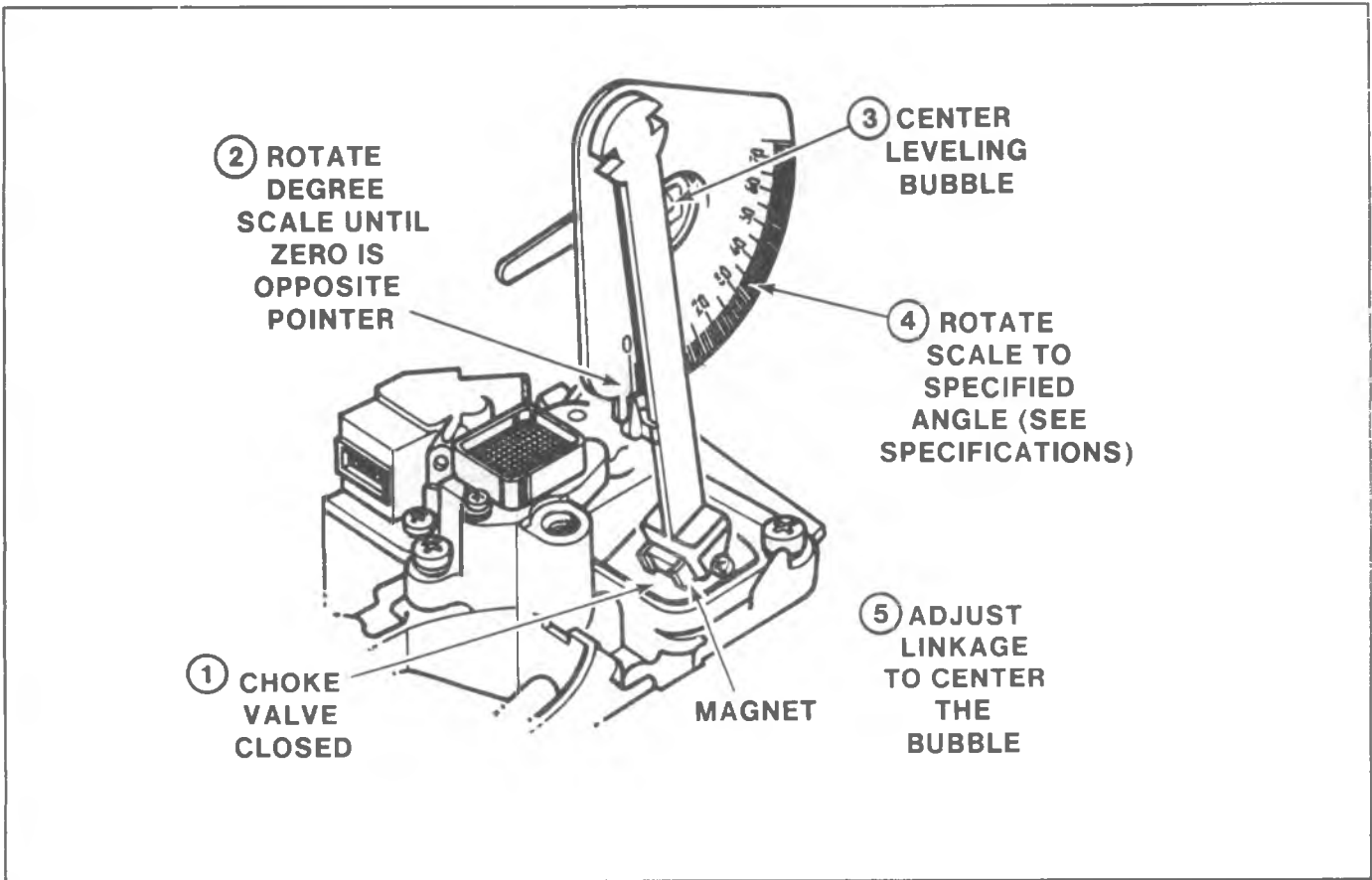

Fig. 6C3-38--Choke Angle Gage

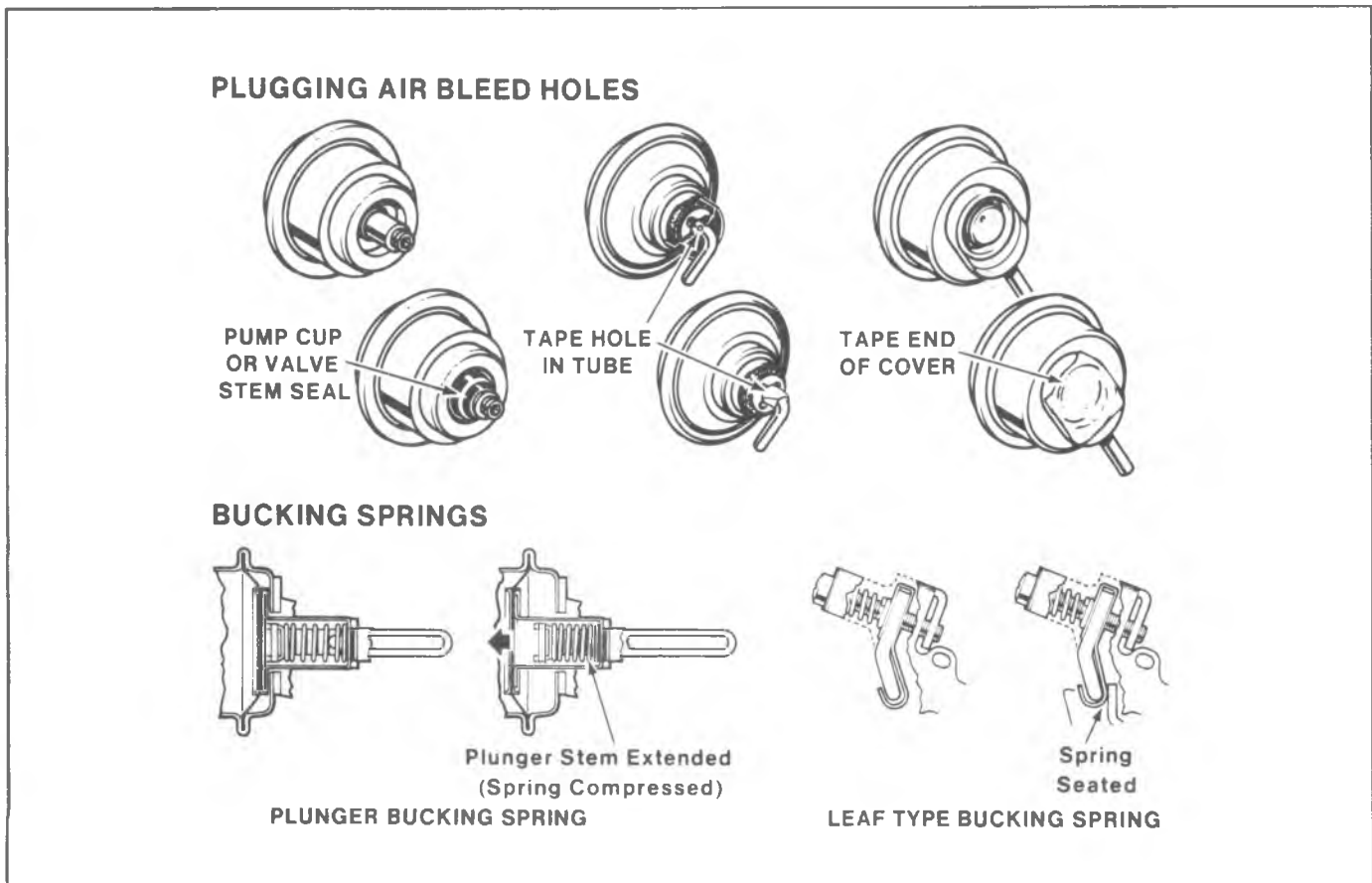

Fig. 6C3-39--Vacuum Break Adjustment Information

- ① ATTACH RUBBER BAND TO INTER-MEDIATE CHOKE LEVER.
- ② OPEN THROTTLE TO ALLOW CHOKE VALVE TO CLOSE.
- ③ SET UP ANGLE GAGE AND SET ANGLE TO SPECIFICATIONS.
- ④ PLACE FAST IDLE SCREW ON SECOND STEP OF CAM AGAINST RISE OF HIGH STEP.
- ⑤ PUSH ON CHOKE SHAFT LEVER TO OPEN CHOKE VALVE AND TO MAKE CONTACT WITH BLACK CLOSING TANG.
- ⑥ SUPPORT AT "S" AND ADJUST BY BENDING FAST IDLE CAM ROD UNTIL BUBBLE IS CENTERED.

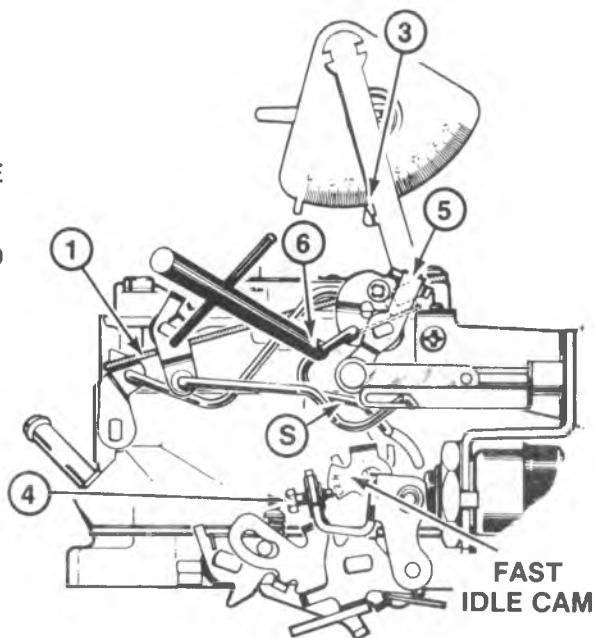

Fig. 6C3-40--Choke Rod Fast Idle Cam Adjustment

- ⑤ AIR VALVE ROD MUST NOT RESTRICT PLUNGER FROM RETRACTING FULLY. IF NECESSARY, SUPPORT AT "5-S" AND BEND ROD (SEE ARROW) TO PERMIT FULL PLUNGER TRAVEL. FINAL ROD CLEARANCE MUST BE SET AFTER VACUUM BREAK SETTING HAS BEEN MADE. WHERE APPLICABLE, PLUNGER STEM MUST BE EXTENDED FULLY TO COMPRESS BUCKING SPRING.
  - ⑥ TO CENTER BUBBLE, EITHER:  
 A ADJUST WITH 1/8" (3.175 mm) HEX WRENCH (VACUUM STILL APPLIED).  
 -OR-  
 B SUPPORT AT "6-S" AND BEND WIRE-FORM VACUUM BREAK ROD. (VACUUM STILL APPLIED).
- ① ATTACH RUBBER BAND TO INTER-MEDIATE CHOKE LEVER.
  - ② OPEN THROTTLE TO ALLOW CHOKE VALVE TO CLOSE.
  - ③ SET UP ANGLE GAGE AND SET ANGLE TO SPECIFICATION.
  - ④ RETRACT VACUUM BREAK PLUNGER USING VACUUM SOURCE, AT LEAST 18" HG. PLUG AIR BLEED HOLES WHERE APPLICABLE.

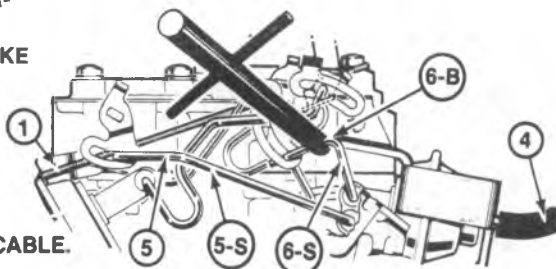
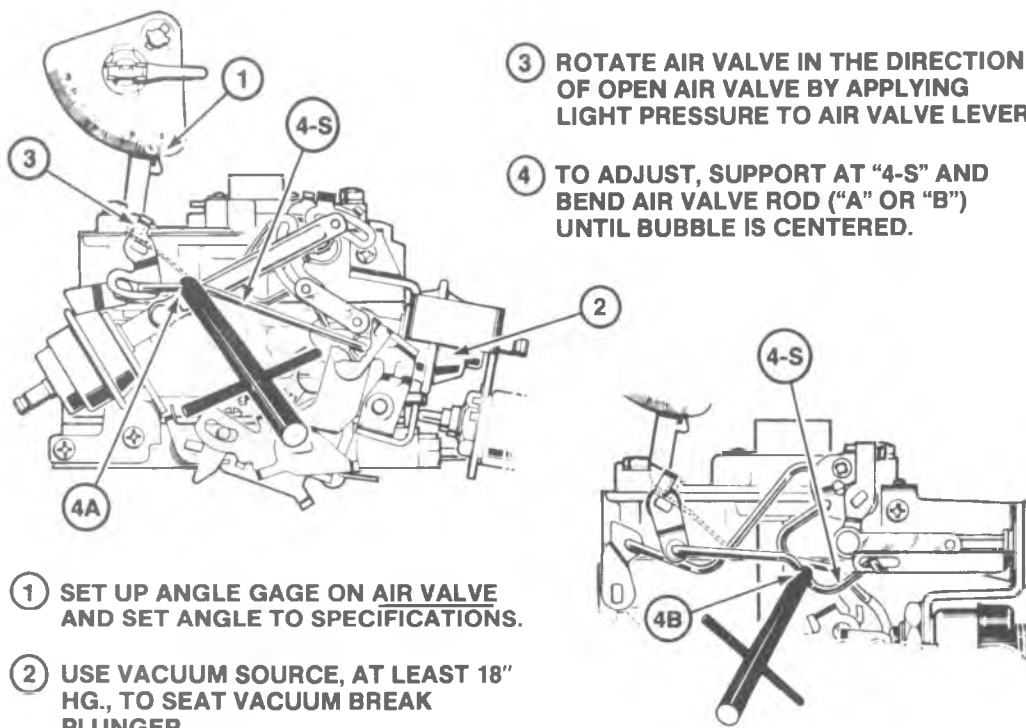

Fig. 6C3-41--Primary Vacuum Break Adjustment



- ① SET UP ANGLE GAGE ON AIR VALVE AND SET ANGLE TO SPECIFICATIONS.
- ② USE VACUUM SOURCE, AT LEAST 18" HG., TO SEAT VACUUM BREAK PLUNGER.
- ③ ROTATE AIR VALVE IN THE DIRECTION OF OPEN AIR VALVE BY APPLYING LIGHT PRESSURE TO AIR VALVE LEVER.
- ④ TO ADJUST, SUPPORT AT "4-S" AND BEND AIR VALVE ROD ("A" OR "B") UNTIL BUBBLE IS CENTERED.

Fig. 6C3-42--Air Valve Rod Adjustment

- ① ATTACH RUBBER BAND TO INTERMEDIATE CHOKE LEVER.
- ② OPEN THROTTLE TO ALLOW CHOKE VALVE TO CLOSE.
- ③ SET UP ANGLE GAGE AND SET ANGLE TO SPECIFICATION.
- ④ RETRACT VACUUM BREAK PLUNGER USING VACUUM SOURCE, AT LEAST 18" HG. PLUG AIR BLEED HOLES WHERE APPLICABLE.  
WHERE APPLICABLE, PLUNGER STEM MUST BE EXTENDED FULLY TO COMPRESS PLUNGER BUCKING SPRING.
- ⑤ TO CENTER BUBBLE, EITHER:
  - A. ADJUST WITH 1/8" (3.175 mm) HEX WRENCH (VACUUM STILL APPLIED)
  - OR
  - B. SUPPORT AT "5-S", BEND WIRE-FORM VACUUM BREAK ROD (VACUUM STILL APPLIED)

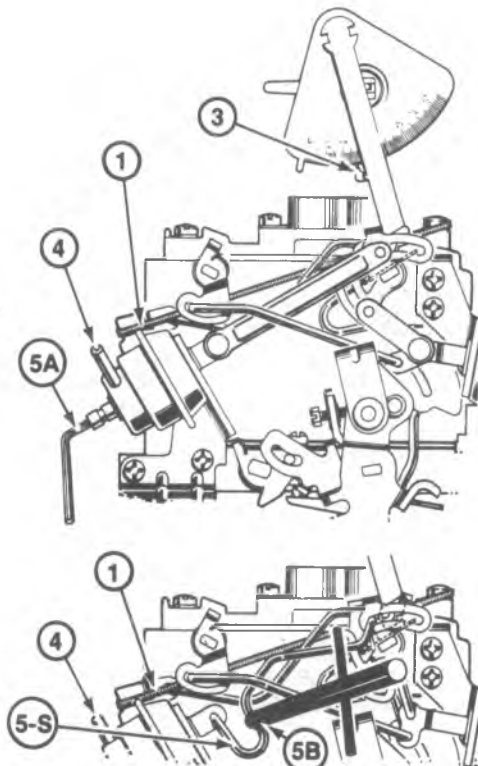

Fig. 6C3-43--Secondary Vacuum Break Adjustment

- ① ATTACH RUBBER BAND TO INTERMEDIATE CHOKE LEVER.
- ② OPEN THROTTLE TO ALLOW CHOKE VALVE TO CLOSE.
- ③ SET UP ANGLE GAGE AND SET ANGLE TO SPECIFICATIONS.
- ④ HOLD THROTTLE LEVER IN WIDE OPEN POSITION.
- ⑤ PUSH ON CHOKE SHAFT LEVER TO OPEN CHOKE VALVE AND TO MAKE CONTACT WITH BLACK CLOSING TANG.
- ⑥ ADJUST BY BENDING TANG UNTIL BUBBLE IS CENTERED.

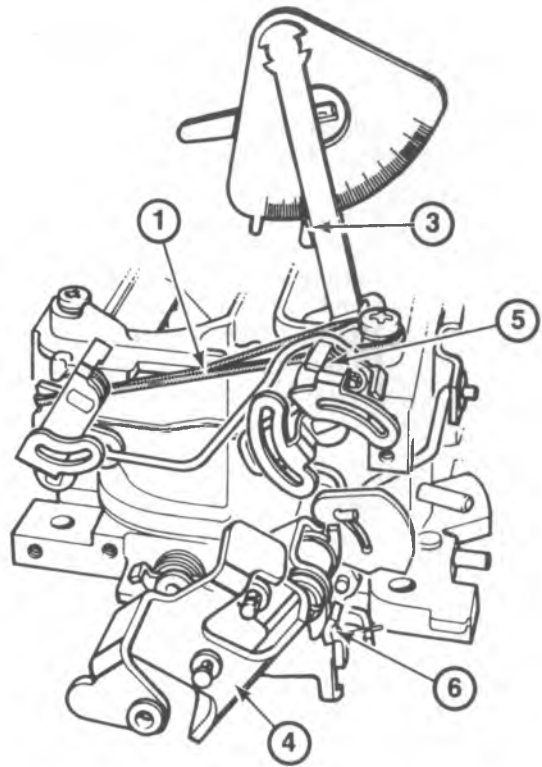

Fig. 6C3-44--Unloader Adjustment

- ① HOLD CHOKE VALVE WIDE OPEN BY PUSHING DOWN ON INTERMEDIATE CHOKE LEVER.
- ② OPEN THROTTLE LEVER UNTIL END OF SECONDARY ACTUATING LEVER IS OPPOSITE TOE OF LOCKOUT LEVER.
- ③ GAGE CLEARANCE - DIMENSION SHOULD BE .025".
- ④ IF NECESSARY TO ADJUST, BEND LOCKOUT LEVER TANG CONTACTING FAST IDLE CAM.

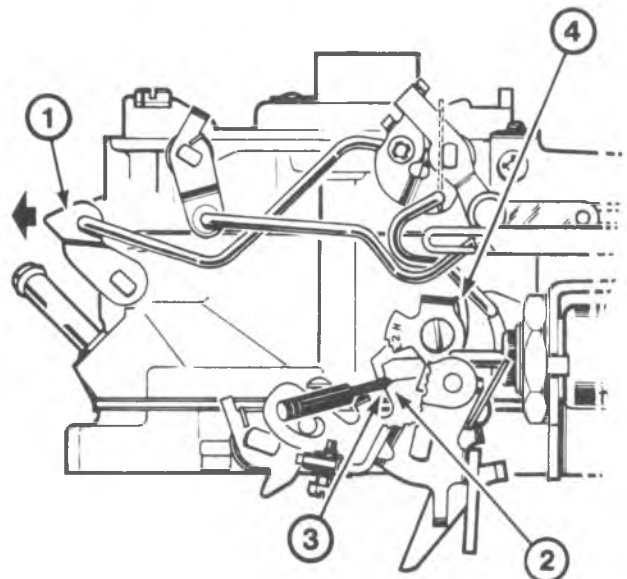

Fig. 6C3-45--Secondary Lockout Adjustment

## SPECIAL TOOLS

|                                  |                      |
|----------------------------------|----------------------|
| Idle Mixture Socket.....         | J-29030-B/BT-7610-B  |
| Float Level Scale .....          | J-9789-90/BT-8037    |
| Bending Tool .....               | J-9789-111/BT-3007   |
| Carburetor Stand.....            | J-9789-118A/BT-30-15 |
| Float Level Gage.....            | J-9789-135/BT-8104   |
| Carburetor Choke Angle Gage..... | J-26701-A/BT-7704    |
| Hand Vacuum Device .....         | J-23738/BT-7517      |
| Metering Jet Remover .....       | J-28696-B/BT-7928    |
| Carburetor Gage Set .....        | J-9789-C/BT-3005-A   |
| Digital Multimeter.....          | J-29125-A/BT-3450    |

MODEL E2SE ADJUSTMENT CARBURETOR SPECIFICATIONS – 2.8L ENGINE

| CARBU-<br>RETOR<br>NUMBER | FLOAT<br>LEVEL |       | AIR<br>VALVE<br>SPRING<br>(TURNS) | CHOKE<br>COIL<br>LEVER | FAST<br>IDLE<br>CAM<br>(CHOKE<br>ROD) | VAC.<br>BREAK<br>PRI. | AIR<br>VALVE<br>ROD | VAC.<br>BREAK<br>SEC. | UN-<br>LOADER |
|---------------------------|----------------|-------|-----------------------------------|------------------------|---------------------------------------|-----------------------|---------------------|-----------------------|---------------|
|                           | mm             | Inch  |                                   |                        |                                       |                       |                     |                       |               |
| 17083356                  | 10.3           | 13/32 | 1                                 | .085                   | 22°                                   | 25°                   | 1°                  | 35°                   | 30°           |
| 17083357                  | 10.3           | 13/32 | 1                                 | .085                   | 22°                                   | 25°                   | 1°                  | 35°                   | 30°           |
| 17083358                  | 10.3           | 13/32 | 1                                 | .085                   | 22°                                   | 25°                   | 1°                  | 35°                   | 30°           |
| 17083359                  | 10.3           | 13/32 | 1                                 | .085                   | 22°                                   | 25°                   | 1°                  | 35°                   | 30°           |
| 17083368                  | 3.3            | 1/8   | 1                                 | .085                   | 22°                                   | 25°                   | 1°                  | 35°                   | 30°           |
| 17083370                  | 3.3            | 1/8   | 1                                 | .085                   | 22°                                   | 25°                   | 1°                  | 35°                   | 30°           |
| 17083450                  | 3.6            | 1/8   | 1                                 | .085                   | 28°                                   | 27°                   | 1°                  | 35°                   | 45°           |
| 17083451                  | 6.6            | 1/4   | 1                                 | .085                   | 28°                                   | 27°                   | 1°                  | 35°                   | 45°           |
| 17083452                  | 3.6            | 1/8   | 1                                 | .085                   | 28°                                   | 27°                   | 1°                  | 35°                   | 45°           |
| 17083453                  | 6.6            | 1/4   | 1                                 | .085                   | 28°                                   | 27°                   | 1°                  | 35°                   | 45°           |
| 17083454                  | 3.6            | 1/8   | 1                                 | .085                   | 28°                                   | 27°                   | 1°                  | 35°                   | 45°           |
| 17083455                  | 6.6            | 1/4   | 1                                 | .085                   | 28°                                   | 27°                   | 1°                  | 35°                   | 45°           |
| 17083456                  | 3.6            | 1/8   | 1                                 | .085                   | 28°                                   | 27°                   | 1°                  | 35°                   | 45°           |
| 17083630                  | 6.5            | 1/4   | 1                                 | .085                   | 28°                                   | 27°                   | 1°                  | 35°                   | 45°           |
| 17083631                  | 6.5            | 1/4   | 1                                 | .085                   | 28°                                   | 27°                   | 1°                  | 35°                   | 45°           |
| 17083632                  | 6.5            | 1/4   | 1                                 | .085                   | 28°                                   | 27°                   | 1°                  | 35°                   | 45°           |
| 17083633                  | 6.5            | 1/4   | 1                                 | .085                   | 28°                                   | 27°                   | 1°                  | 35°                   | 45°           |
| 17083634                  | 6.5            | 1/4   | 1                                 | .085                   | 28°                                   | 27°                   | 1°                  | 35°                   | 45°           |
| 17083635                  | 6.5            | 1/4   | 1                                 | .085                   | 28°                                   | 27°                   | 1°                  | 35°                   | 45°           |
| 17083636                  | 6.5            | 1/4   | 1                                 | .085                   | 28°                                   | 27°                   | 1°                  | 35°                   | 45°           |
| 17083650                  | 3.6            | 1/8   | 1/2                               | .085                   | 28°                                   | 27°                   | 1°                  | 35°                   | 45°           |

MODEL E2SE ADJUSTMENT CARBURETOR SPECIFICATIONS – 4.1L ENGINE

| CARBU-<br>RETOR<br>NUMBER | FLOAT<br>LEVEL |       | AIR<br>VALVE<br>SPRING<br>(TURNS) | CHOKE<br>COIL<br>LEVER | FAST<br>IDLE<br>CAM<br>(CHOKE<br>ROD) | VAC.<br>BREAK<br>PRI. | AIR<br>VALVE<br>ROD | VAC.<br>BREAK<br>SEC. | UN-<br>LOADER |
|---------------------------|----------------|-------|-----------------------------------|------------------------|---------------------------------------|-----------------------|---------------------|-----------------------|---------------|
|                           | mm             | Inch  |                                   |                        |                                       |                       |                     |                       |               |
| 17083430                  | 8.65           | 11/32 | 1                                 | .085                   | 15°                                   | 26°                   | 1°                  | 38°                   | 42°           |
| 17083431                  | 8.65           | 11/32 | 1                                 | .085                   | 15°                                   | 26°                   | 1°                  | 38°                   | 42°           |
| 17083434                  | 8.65           | 11/32 | 1                                 | .085                   | 15°                                   | 26°                   | 1°                  | 38°                   | 42°           |
| 17083435                  | 8.65           | 11/32 | 1                                 | .085                   | 15°                                   | 26°                   | 1°                  | 38°                   | 42°           |

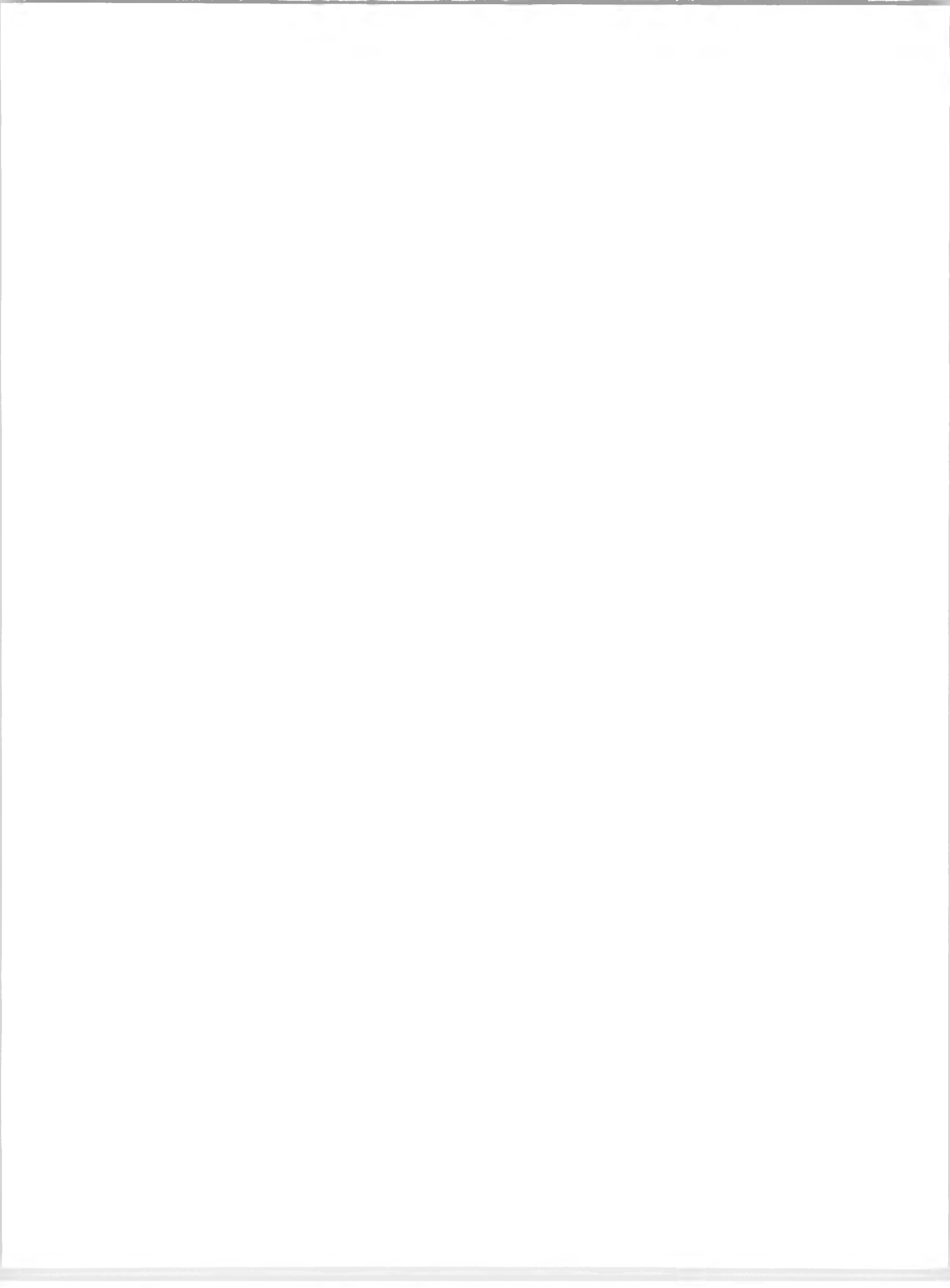

# SECTION 6C7

## CARBURETOR MODEL 1ME

### CONTENTS

|                                 |       |                                |        |
|---------------------------------|-------|--------------------------------|--------|
| General Description.....        | 6C7-1 | Choke Coil Replacement.....    | 6C7-6  |
| On-Vehicle Service.....         | 6C7-3 | Throttle Lever Actuator.....   | 6C7-6  |
| Adjustments.....                | 6C7-3 | Unit Repair.....               | 6C7-6  |
| Choke Checking Procedure.....   | 6C7-3 | Disassembly.....               | 6C7-6  |
| Idle Mixture Adjustment.....    | 6C7-4 | Cleaning.....                  | 6C7-9  |
| Carburetor Mounting Torque..... | 6C7-5 | Assembly.....                  | 6C7-9  |
| Carburetor Replacement.....     | 6C7-5 | Adjustment Specifications..... | 6C7-14 |
| Solenoid Replacement.....       | 6C7-5 |                                |        |

### GENERAL DESCRIPTION

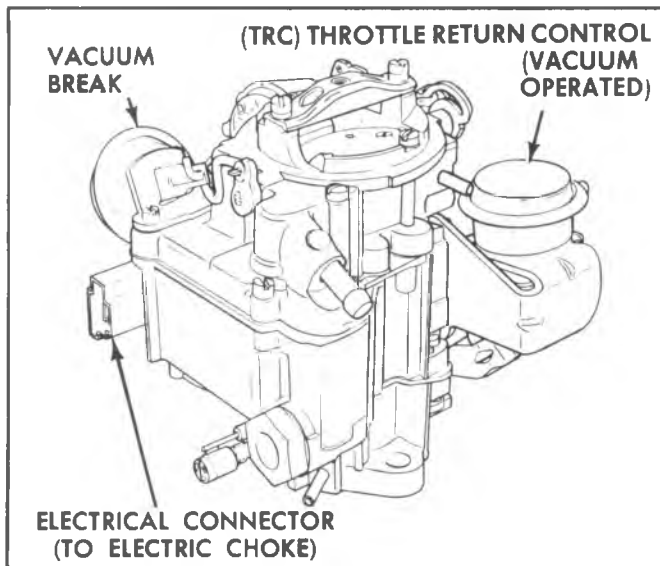

Fig. 6C1-1--Model 1ME Carburetor

The Model 1ME, carburetor (Fig. 6C1-1) is a single bore downdraft carburetor using a triple venturi in conjunction with a plain tube nozzle.

Fuel flow through the main metering system is controlled by a main well air bleed and a variable orifice jet. A power enrichment system is used to provide good performance during moderate to heavy acceleration and at higher engine speeds.

The model 1ME incorporates an integral automatic choke system which uses an electrically heated choke coil. The vacuum diaphragm unit is mounted externally on the air horn and connects to the thermostatic coil lever through a connecting link.

The electric choke coil is contained in a choke housing mounted on a bracket attached to the float bowl. Special rivets are installed to retain the factory setting of the choke coil and provide a non-adjustable design.

An integral, pleated-paper fuel inlet filter is mounted in the fuel bowl behind the fuel inlet nut to give maximum filtration of incoming fuel. A check valve is used in the filter inlet to prevent fuel draining from the fuel system after roll-over.

To improve hot engine starting and meet evaporative emission requirements, fuel vapors from the carburetor bowl are vented to the vapor canister on all Calif. models. A tube (location F) is added to the air horn to connect air horn and canister.

Other features of the Model 1ME carburetor include an aluminum throttle body for decreased weight and improved heat distribution and a thick throttle body to bowl insulator gasket to keep excessive engine heat from the float bowl.

On California models, seals have been added in the float bowl to seal the power piston drive rod and the pump lever to prevent escape of fuel vapors to atmosphere. During unit repair, the seals and retainer, where used, must be removed prior to immersion of the float bowl in carburetor cleaner.

The carburetor model identification is stamped on a vertical portion of the float bowl, adjacent to the fuel inlet nut (Fig. 6C1-2).

If replacing the float bowl, follow the manufacturer's instructions contained in the service package so that the identification number can be transferred to the new float bowl.

An electrically operated idle stop solenoid is used on all models.

Dual throttle return springs are used on all carburetors.

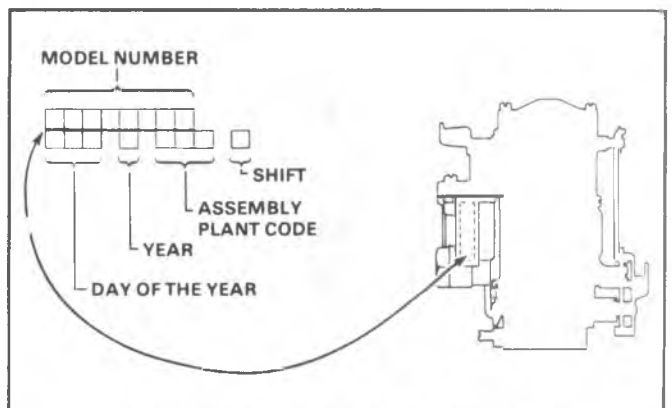

Fig. 6C1-2--Model 1ME Carburetor Identification



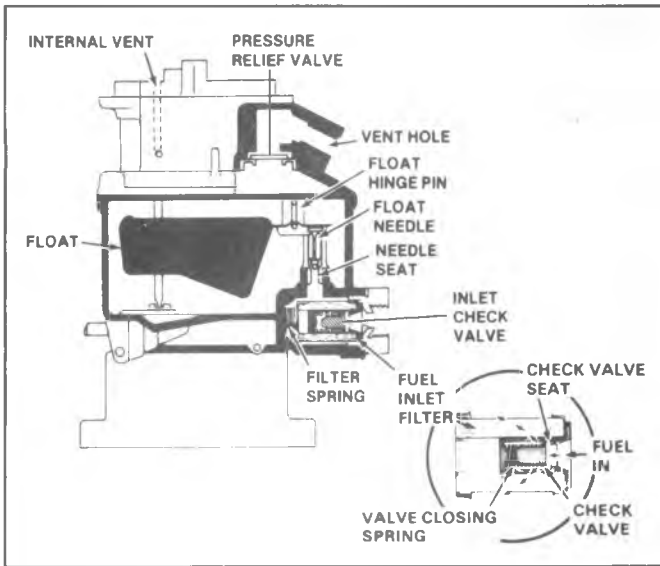

Fig. 6C1-3--Float System

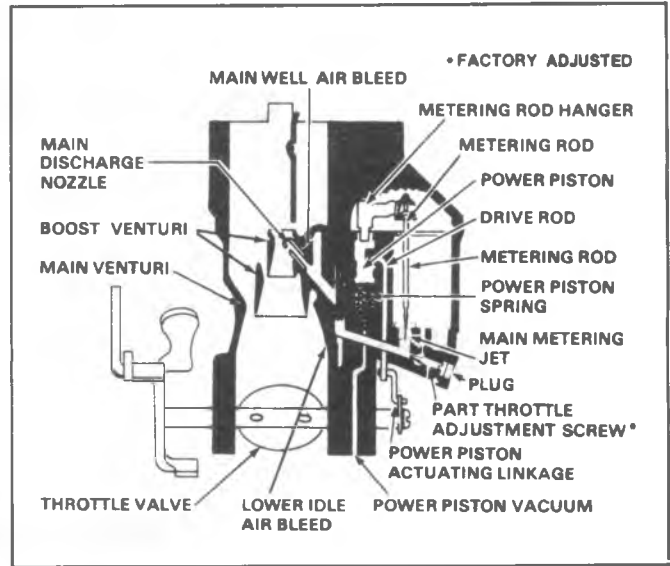

Fig. 6C1-6--Power Enrichment System

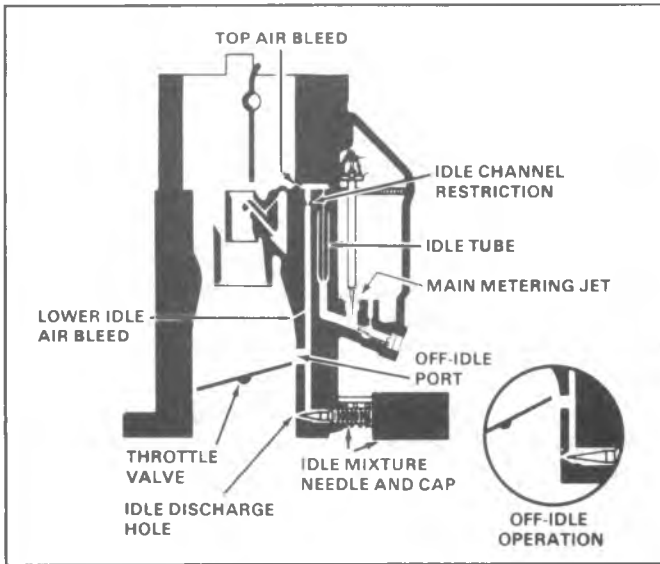

Fig. 6C1-4--Idle System

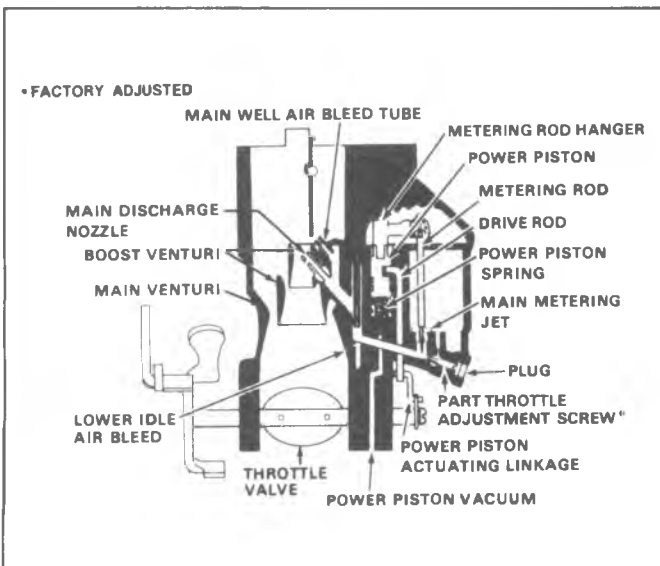

Fig. 6C1-5--Main Metering System Typical

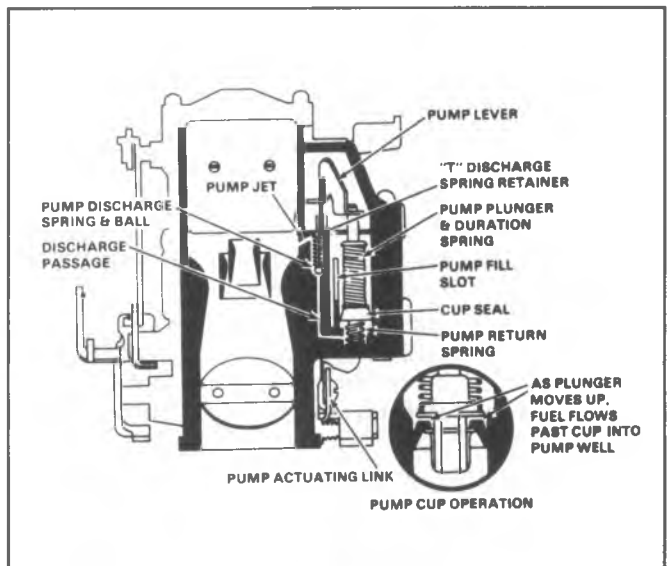

Fig. 6C1-7--Pump System

The throttle lever has a spun-in plastic bushing, this is used as the bearing surface for the dual throttle return springs.

The spun-in plastic return spring bushing will withstand normal cleaning time in an approved cold immersion type carburetor cleaner. The bushing is not serviced separately and should not be removed from the carburetor throttle lever.

Six basic systems of operation are used: float, idle, main metering, power enrichment, pump and choke (6C1-3 through 8).

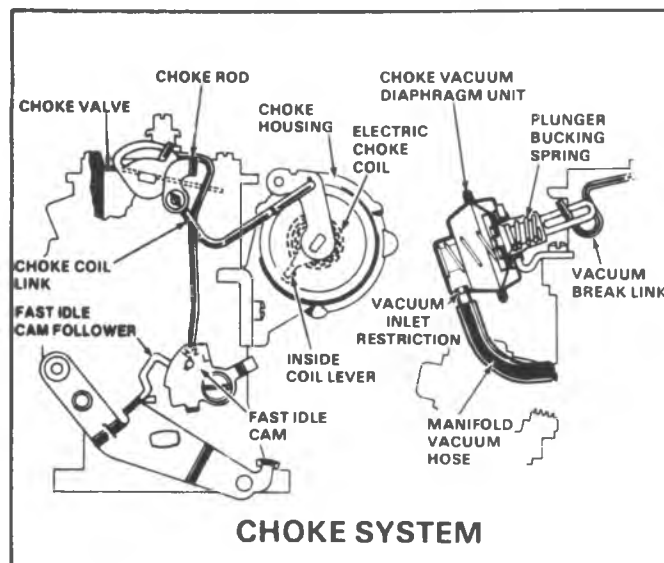

Fig. 6C1-8--Choke System

## ON-VEHICLE SERVICE

### CHOKE CHECKING PROCEDURE

1. Remove air cleaner. With engine off, hold throttle half open. Open and close choke several times. Watch linkage to be certain all links are connected and there are no signs of damage.
2. If choke or linkage binds, sticks, or works sluggishly, clean with Choke Cleaner X-20-A or equivalent. Use cleaner as directed on can. Refer to disassembly instructions for additional direction if cleaning does not correct.
3. Visually inspect carburetor to be certain all vacuum hoses are connected. Inspects hoses for cracks, abrasions, hardness or other signs of deterioration. Replace or correct as necessary.
4. Make sure vacuum break diaphragm shaft is fully extended when engine is off. If shaft is not fully extended, replace vacuum break assembly. Start engine - vacuum break diaphragm shaft should fully retract within 10 seconds. If unit fails to retract, replace vacuum break assembly.
5. Allow choke to cool so that when throttle is opened slightly choke blade fully closes. This check must be performed at an ambient temperature of 16°C to 27°C (60°F to 80°F).
6. Start engine and determine time for choke blade to reach full open position. (Start timer when engine starts).
7. If the choke blade fails to open fully within 3-1/2 minutes, proceed with steps 8-9-10 below.
8. Check voltage at the choke heater connection. (Engine must be running). If the voltage is approximately 12-15 volts, replace the electric choke unit.
9. If the voltage is low or zero, check all wires and connections. If the connections at the oil pressure switch are faulty, the oil warning light will be off with the key "on" and engine off. If the fuse is blown, the radio or turn signal indicator will be inoperative. Repair wires or replace fuses as required.

10. If step 9 is good, replace oil pressure switch.

No gasket is used between the choke cover and the choke housing due to grounding requirements.

### CHECKING SOLENOID

1. Turn on ignition, but do not start engine.
2. Open throttle to allow solenoid plunger to extend.
3. Hold throttle lever wide open, feel end of plunger and disconnect wire at solenoid.
4. Plunger should move. Some spring tension should be felt.
5. If plunger did not move, back out 1/8 hex screw (counterclockwise) one full turn and repeat steps 3 and 4.
6. If plunger moves in step 5, connect wire to solenoid and adjust idle speed.
7. If plunger did not move in step 5 insert test lamp (1893 bulb or smaller) between solenoid feed wire and ground.
8. If lamp lights, replace solenoid.
9. If lamp does not light, locate cause of open circuit in solenoid feed wire.

### CARBURETOR ADJUSTMENTS

A carburetor is designed to meet the particular requirements of the engine, transmission and vehicle and although they may look alike, they are not usually interchangeable. Refer to carburetor part number and/or specifications when making adjustments.

Before checking or resetting the carburetor as the cause of poor engine performance or rough idle; check ignition system including distributor, timing, spark plugs and wires. Check air cleaner, evaporative emission system, EFE System, PCV system, EGR valve and engine compression. Also inspect intake manifold, vacuum hoses and connections for leaks and check torques of carburetor mounting bolts/nuts.

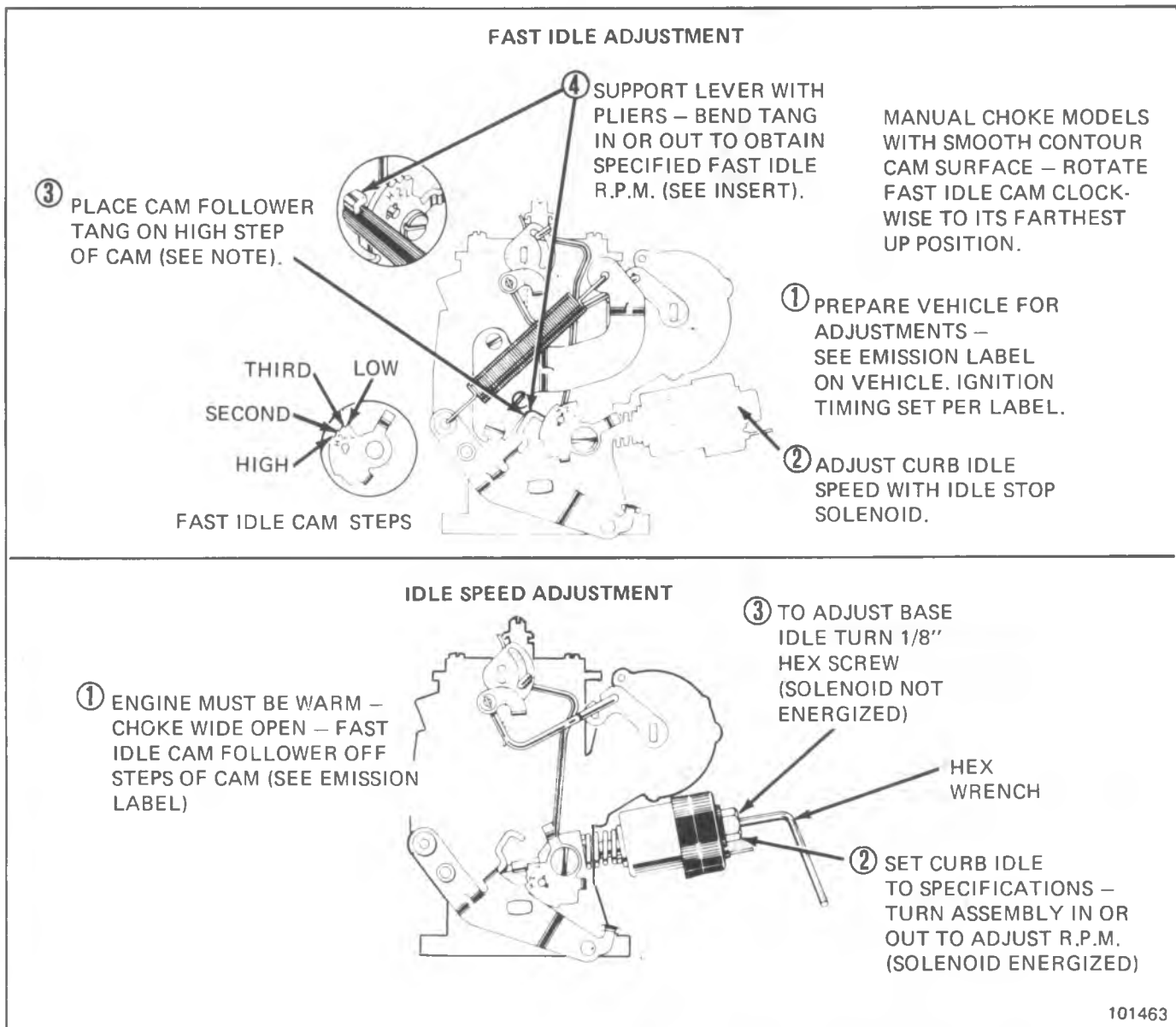

Fig. 6C1-9--Speed Adjustments

Make all adjustments with engine at normal operating temperature, choke full open, air cleaner installed. Except as noted, air conditioning should be "off" and all vacuum lines and all electrical leads connected. Set parking brake and block drive wheels. Air cleaner can be removed for set-up accessibility but must be completely installed during actual setting.

Refer to Figure 6C1-9 for fast idle and idle speed adjustments.

### IDLE MIXTURE ADJUSTMENT (LEAN DROP)

1. Set parking brake and block drive wheels.
2. Remove air cleaner for access to carburetor, but keep vacuum hoses connected.
3. Disconnect and plug other hoses, as directed on Vehicle Emission Control information label under the hood.
4. Place transmission in Neutral or Park.
5. Start engine and bring to normal operating temperature, choke open, air conditioning off.

6. Connect an ACCURATE tachometer to engine.
7. Disconnect vacuum advance and plug hose. Check ignition timing. If necessary, adjust to specification shown on Vehicle Emission Control Information label. Reconnect vacuum advance.
8. Carefully remove cap from idle mixture screw. Be careful not to bend screw. Lightly seat screw, then back out just enough so engine will run.
9. Back screw out (richen) 1/8 turn at a time until maximum idle speed is obtained. Then set idle speed to higher value shown on Vehicle Emission Control Information label. Repeat step 9 to be certain you have maximum idle speed.
10. Turn screw in (lean) with 1/8 turn increments until idle speed reaches a lower value shown on Vehicle Emission Control Information label.
11. Reset idle speed to specification shown on Vehicle Emission Control Information label.
12. Check and adjust fast idle as described on the

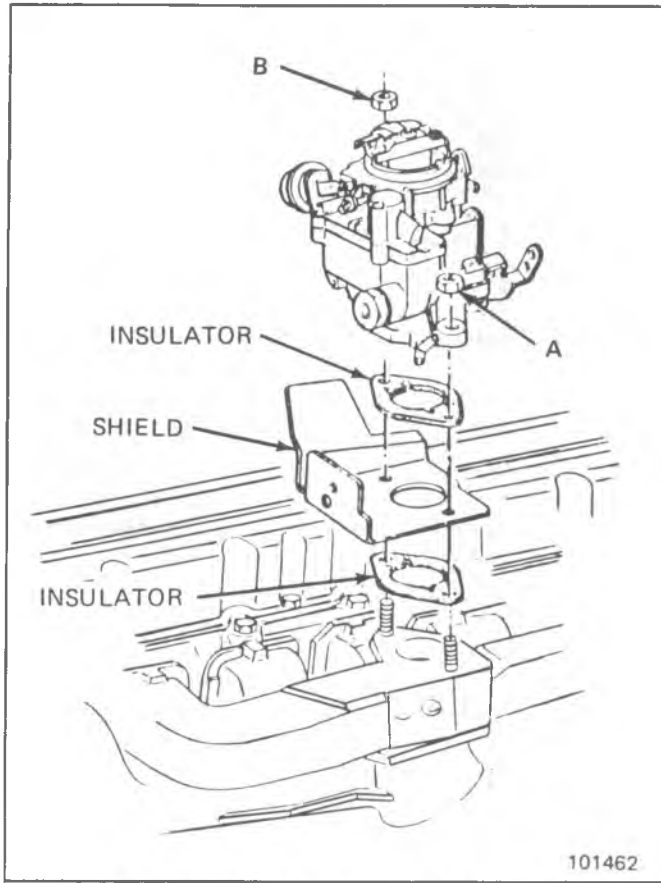

Fig. 6C1-10-1ME Carburetor Replacement

vehicle Emission Control Information label.

13. Reconnect vacuum hoses. Install air cleaner.
14. Recheck idle speed. If necessary, reset to specification.

### CARBURETOR MOUNTING TORQUE

When torquing carburetor after removal, overhaul, replacement or when installing a new heat insulators, torque mounting nuts A and B to 4 N·m (37 in. lbs.) and then retorque to 22 N·m (16 ft. lbs.).

### CARBURETOR REPLACEMENT (FIG. 6C1-10)

#### Removal

Flooding, stumble on acceleration and other performance complaints are, in many instances, caused by presence of dirt, water, or other foreign matter in carburetor. To aid in diagnosing cause, carburetor should be carefully removed from engine without draining fuel from bowl. Contents of fuel bowl may then be examined for contamination as carburetor is disassembled. Check filter.

1. Remove air cleaner.
2. Disconnect fuel and vacuum lines from carburetor.
3. Disconnect electrical connector at choke.
4. Disconnect accelerator linkage.
5. Disconnect solenoid electrical connector.
6. Remove carburetor attaching nuts and remove carburetor and solenoid assembly attachment.
7. Remove insulator gaskets and shield.

#### Installation

It is good shop practice to fill carburetor bowl before installing carburetor. This reduces strain on starting motor and battery and reduces the possibility of backfiring while attempting to start engine. A small supply of fuel will enable carburetor to be filled and the operation of float and intake needle and seat to be checked. Operate throttle lever several times and check discharge from pump jets before installing carburetor.

1. Be certain throttle body and intake manifold sealing surface are clean.
2. Install carburetor insulators and shield.
3. Install carburetor over manifold studs.
4. Install vacuum and fuel lines at carburetor
5. Install attaching nuts and tighten alternately to 4 N·m (37 in. lbs.) and the retorque to 22 N·m (16 ft. lbs.).
6. Tighten fuel line.
7. Connect accelerator linkage.
8. Connect choke and solenoid electrical connectors.
9. Install air cleaner.
10. Check and adjust idle speed.

### SOLENOID REPLACEMENT

An inoperative solenoid should be replaced.

#### Removal

1. Remove carburetor air cleaner.
2. Disconnect electrical connector at solenoid.
3. Unscrew and remove solenoid from float bowl assembly.

#### Installation

1. Hold choke valve wide open so that fast idle cam follower clears fast idle cam.
2. Install solenoid and turn in until it contacts lever tang.
3. Connect electrical connector.
4. Install air cleaner.
5. Check and adjust idle speed.

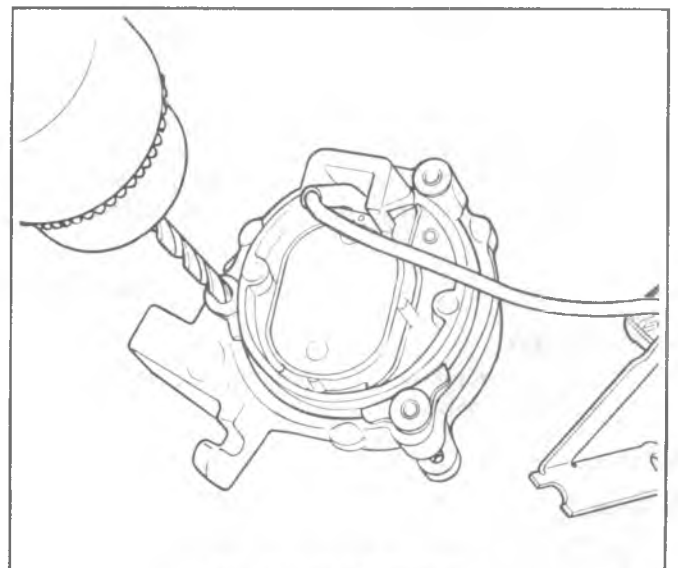

Fig. 6C1-11-Choke Coil

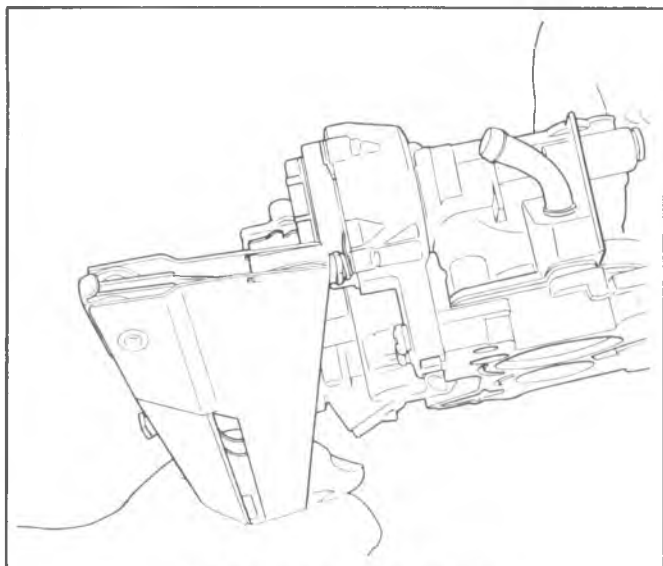

Fig. 6C1-12--Installing Choke

### CHOKE COIL REPLACEMENT (Fig. 6C1-11a)

Choke mechanism should be checked for free operation. A binding condition may have developed from petroleum gum formation on the choke shaft or from damage. Choke shafts can usually be cleaned without disassembly by using Carbon X(X55) or equivalent.

1. Remove air cleaner and disconnect choke electrical connector.
2. Align a #21 drill (.159") on rivet head and drill only enough to remove rivet head. After removing rivet heads and retainers, use a drift and small hammer to drive the remainder of the rivets out of the choke housing. Use care in drilling to prevent damage to choke cover or housing. Remove the three retainers and choke cover assembly from choke housing.
3. Remove choke coil from housing.
4. Install the choke cover and coil assembly in choke housing as follows:

a. Install the choke cover and coil assembly in the choke housing, aligning notch in cover with raised casting projection on housing cover flange. Make sure coil pick-up tang engages the inside choke coil lever.

### DISASSEMBLY

Place carburetor on a holding fixture to prevent damage to throttle valve.

#### Air Horn

##### Removal

1. Remove choke vacuum break diaphragm hose.
2. Remove vacuum break diaphragm assembly from air horn by removing two attaching screws. These screws have a tapered head and do not use lockwashers. Remove diaphragm plunger stem from diaphragm to choke lever link. (Fig. 6C1-14).

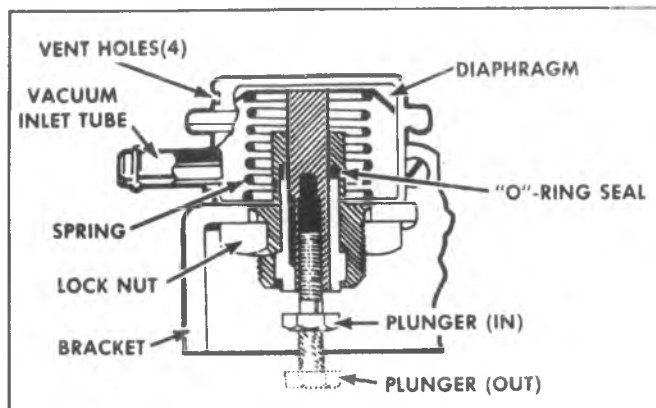

Fig. 6C1-13--Throttle Return Control

A choke cover retainer kit is required to attach choke cover to choke housing. Install proper retainers and rivets contained in kit using suitable blind rivet installing tool (Fig. 6C1-12).

5. Connect choke electrical connector.
6. Start engine, check operation of choke and then install air cleaner.

### THROTTLE LEVER ACTUATOR ADJUSTMENT (Fig. 6C1-13)

Adjust the Throttle Return Control (TRC) idle speed to specification, shown on Vehicle Emission label, as follows:

1. Disconnect hose from solenoid valve to actuator at the solenoid valve, and connect hose to an external vacuum source equipped with a vacuum gage.
2. Check the throttle lever, shaft, and linkage to be sure that they operate freely without binding or sticking.
3. Start engine, run until warmed up and idle is stable (transmission in Park or Neutral).
4. Apply 68 kPa (20 in. Hg.) vacuum to the actuator. Manually open the throttle slightly and allow to close against the extended actuator plunger. Note the engine rpm.
5. If the rpm is not within the specified TRC speed range, then turn the screw on the actuator plunger in the appropriate direction and repeat step 3 until the specified TRC speed range is obtained.

### CARBURETOR ADJUSTMENTS

Refer to Figures 6C1-29 and 6C1-30 for carburetor adjustments.

## UNIT REPAIR

**NOTICE:** Screw that retains vacuum break lever to choke shaft is installed with thread torque retaining compound. It is not necessary to remove this screw and lever unless choke shaft replacement is required.

3. Remove fast idle cam attaching screw; then remove fast idle cam (Fig. 6C1-16).  
Remove choke rod from choke coil lever on end of choke shaft.
4. Remove choke coil assembly as follows: Align a #21 drill (.159") on rivet head and drill only

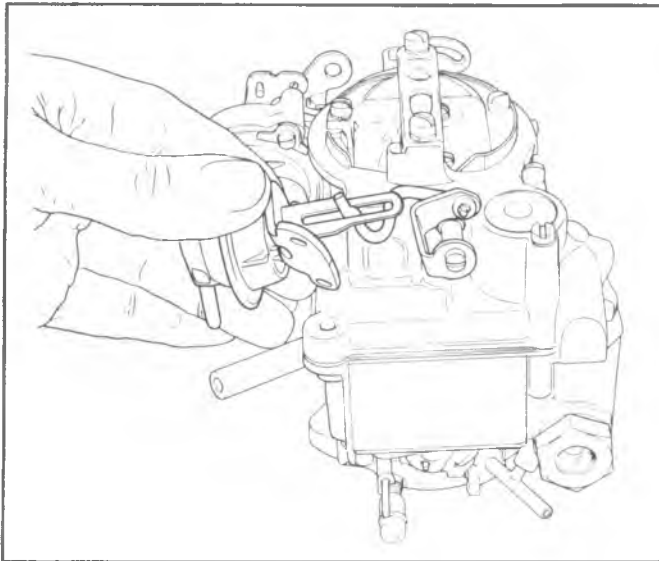

Fig. 6C1-14--Vacuum Break Diaphragm

enough to remove rivet head. Drill the two remaining rivet heads and then use a drift and small hammer to drive the remainder of the rivets out of the choke housing. Remove the three retainers and choke cover assembly from choke housing.

5. Choke coil housing need not be removed from float bowl unless replacement is necessary. To remove choke housing, remove three attaching screws from float bowl. Two screws have lockwashers and the one facing the choke housing has a tapered head for locating choke housing.
6. Remove four remaining air horn to bowl attaching screws and lockwashers (three long and one short screw).
7. Remove air horn by lifting and twisting back towards choke housing so that the choke coil lever link will disengage from the choke coil lever at the choke housing, invert and place on clean bench. Air horn to float bowl gasket can remain on bowl for removal later (Fig. 6C1-16).



Fig. 6C1-16--Air Horn Removal

**Disassembly**

1. If required, the choke valve and choke shaft can be removed from air horn by removing the screw that retains the vacuum break lever to the choke shaft. Care should be exercised when removing this screw because it is retained in place by thread torque retaining compound. Remove the two attaching screws from the choke valve, then, remove the choke valve and choke shaft from air horn.

The choke valve screws are staked in place so it will be necessary to file off staking and re-stake during assembly. Do not bend choke shaft when restaking.

2. No further disassembly of the air horn is necessary.

**Float Bowl Disassembly**

1. Remove air horn to float bowl gasket. Gasket is slit next to metering rod lever so that it can be slid over lever for ease in removal. (Fig. 6C1-17).
2. Remove float assembly from float bowl by lifting



Fig. 6C1-15--Fast Idle Cam

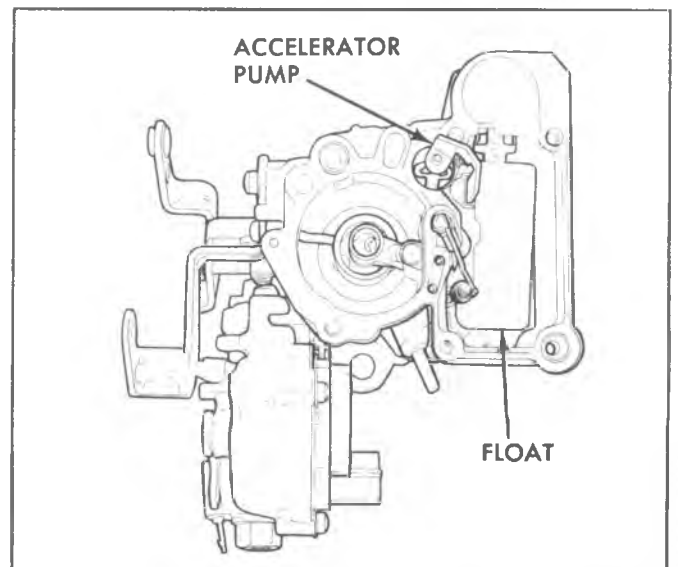

Fig. 6C1-17--Float Bowl Disassembly

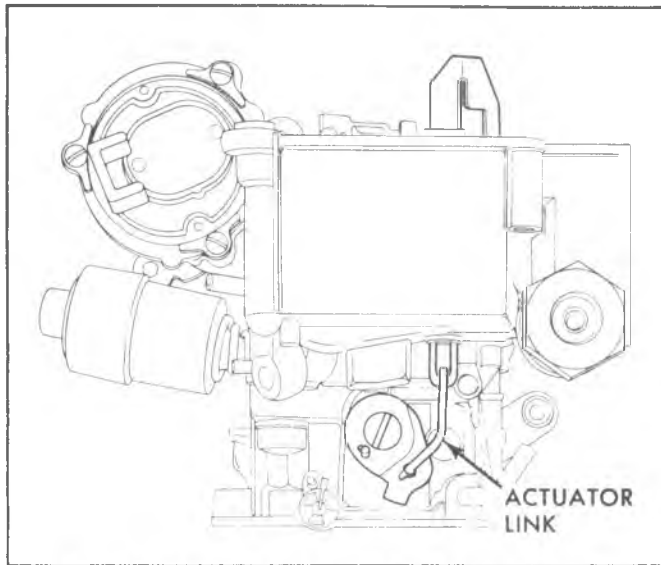

Fig. 6C1-18--Pump and Power Piston Actuator Lever

upward on float hinge pin. Remove hinge pin from float arm.

3. Remove float needle from seat.
4. Disconnect accelerator pump and power piston actuator lever from end of throttle shaft by removing lever attaching screw (Fig. 6C1-18).
5. Hold down on power piston while removing lever. Power piston spring and metering rod assembly may now be removed from float bowl (Fig. 6C1-19).
6. Remove lower end of power piston link from actuator lever by rotating until tang on rod slides out of notch in lever.
7. Remove actuator lever from lower end of accelerator pump link in same manner.
8. Push down on accelerator pump and remove actuator link by rotating until tang on rod aligned with slot on pump plunger lever. Remove the link.
9. Remove pump assembly from float bowl (Fig. 6C1-20).
10. Remove pump return spring and power piston spring from float bowl (Fig. 6C1-20).

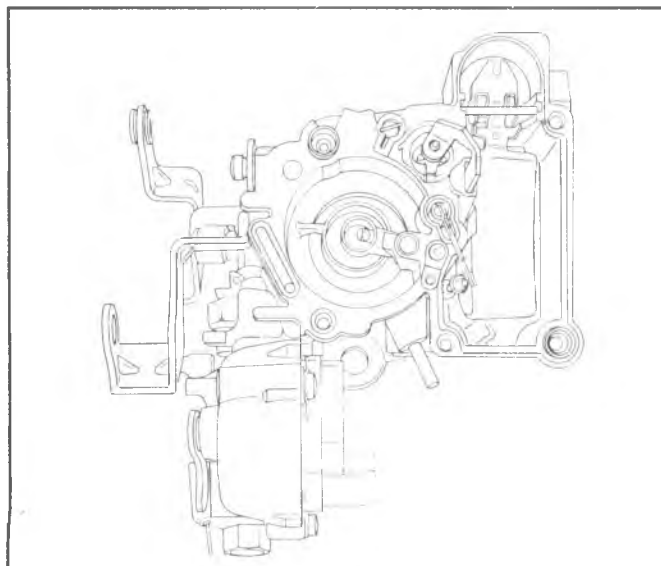

Fig. 6C1-19--Float Bowl Assembly

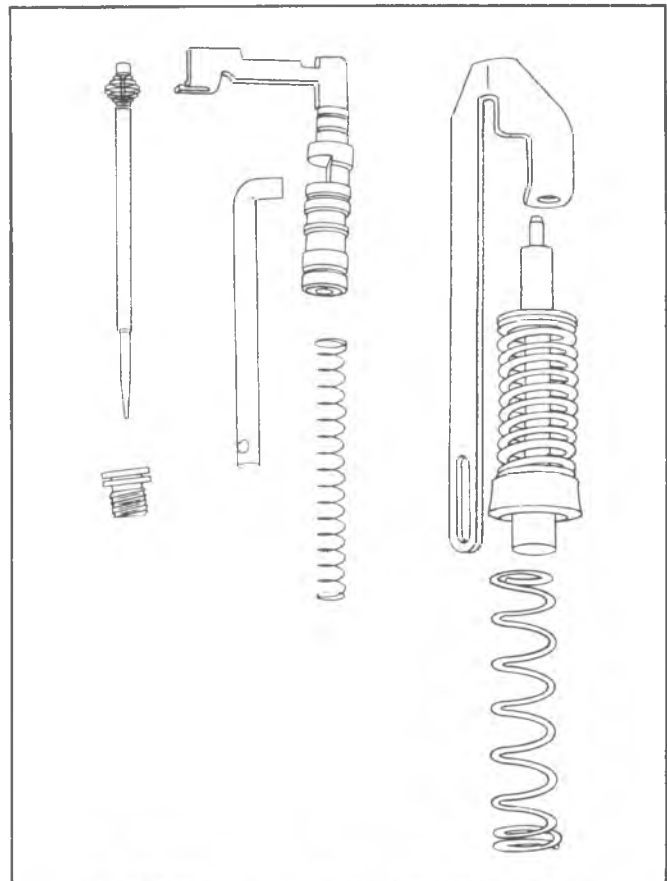

Fig. 6C1-20--Metering Rod and Accelerator Pump

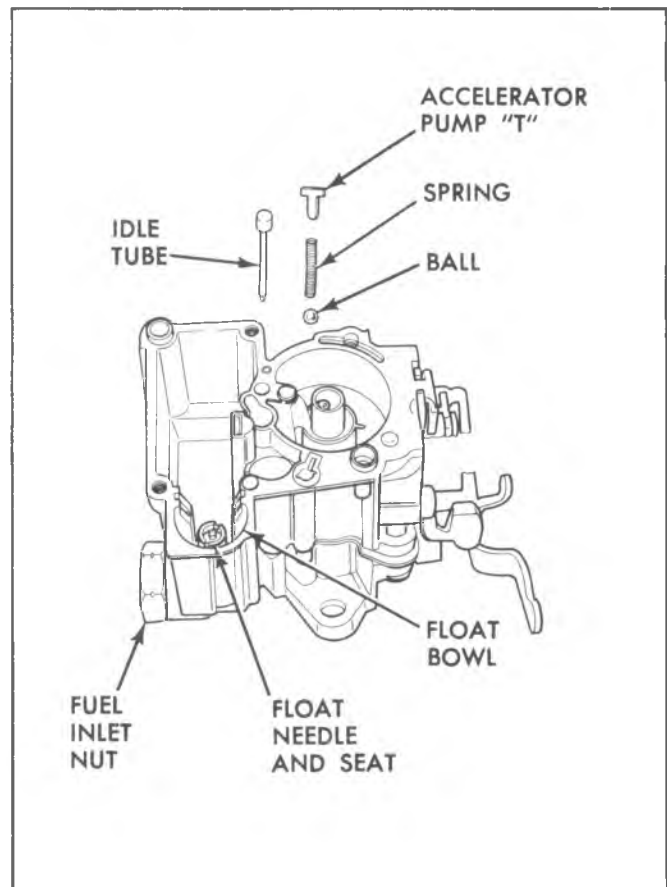

Fig. 6C1-21--Pump Discharge "T" Retainer



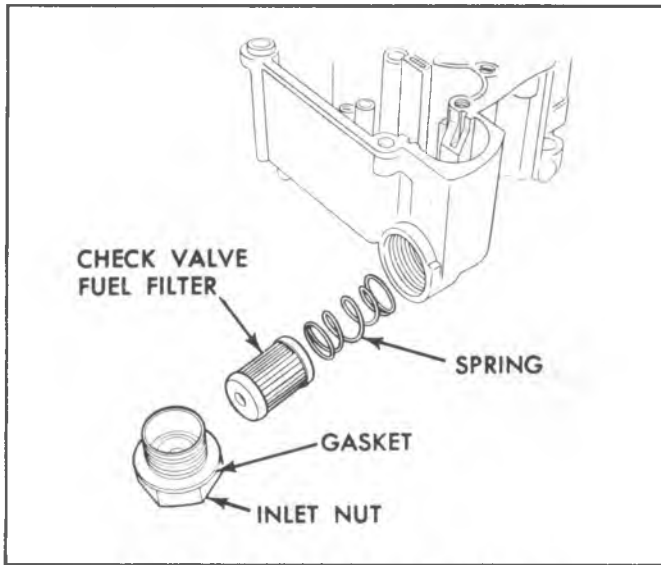

Fig. 6C1-22--Fuel Filter and Check Valve

11. Remove "T" guide and pump discharge spring using needle nose pliers (Fig. 6C1-21).
12. Pump discharge ball and idle tube can be removed at the same time by inverting the bowl.
13. Remove main metering jets from bottom of fuel bowl.
14. Remove float needle seat and gasket using Tool J-22769.
15. The idle stop solenoid can be removed at this time if desired.
16. Remove the fuel inlet nut, filter and spring (Fig. 6C1-22).  
No further disassembly of the float bowl is required.

### Throttle Body (Fig. 6C1-23)

1. Invert carburetor bowl on bench and remove two throttle body to bowl attaching screws. Throttle body and insulator gasket may now be removed.
2. No further disassembly of the throttle body is necessary unless the idle mixture needle is damaged or the idle channels need cleaning. If necessary to remove the idle mixture needle, cut the tang from the plastic limiter cap. Do not install a replacement cap as a bare mixture screw is sufficient to indicate that the mixture has been readjusted.

Due to the close tolerance fit of the throttle valve in the bore of the throttle body, do not remove the throttle valve or shaft.

### CLEANING AND INSPECTION

The carburetor should be cleaned in a cold immersion type cleaner. Rubber and plastic parts should not be immersed in carburetor cleaner. However, the air horn which has the plastic relief valve will withstand normal cleaning in carburetor cleaner.

1. Thoroughly clean carburetor castings and metal parts in an approved carburetor cleaner such as Carbon X (X-55) or equivalent.
2. Blow out all passages in castings with compressed air. Do not pass drills through jets or passages.
3. Examine float needle and seat assembly for wear. Install a new factory matched set if worn.

4. Inspect upper and lower casting sealing surfaces for damage.
5. Inspect holes in levers for excessive wear or out of round condition. If levers are worn they should be replaced.
6. Examine fast idle cam for excessive wear or damage.
7. Check throttle and choke levers and valve for binds and other damage.
8. Check all springs for distortion or loss in tension; replace as necessary.

### CARBURETOR ASSEMBLY

After carburetor has been disassembled, new gaskets and filter must be used.

### Throttle Body (Fig. 6C1-23)

1. If removed, install idle mixture needle and spring into throttle body until lightly seated. Back out two turns as a preliminary adjustment. Final idle mixture adjustment will be made on vehicle.
2. Invert float bowl and install new throttle body to bowl insulator gasket.
3. Install throttle body on bowl gasket so all holes in throttle body are aligned with holes in gasket.
4. Install two throttle body to bowl attaching screws and lockwashers. Tighten even and securely to 20 N·m (15 ft. lbs.).

### Float Bowl

1. Install fuel filter spring, filter, and check valve assembly, (if used), inlet nut and gasket rubber seal on check valve faces fuel inlet nut.

The fuel inlet check valve must be installed (where required) in the filter to meet Motor Vehicle Safety Standards (M.V.S.S.) for roll-over. New service replacement filter include the check valve, where required.

2. Install idle stop solenoid and spring, if removed. Adjust later for correct idle speed.
3. Install main metering jet into bottom of fuel bowl. Tighten securely.
4. Using wide blade screwdriver install needle seat and gasket.
5. Install idle tube flush with bowl casting.
6. Install pump ball, spring and "T" into pump

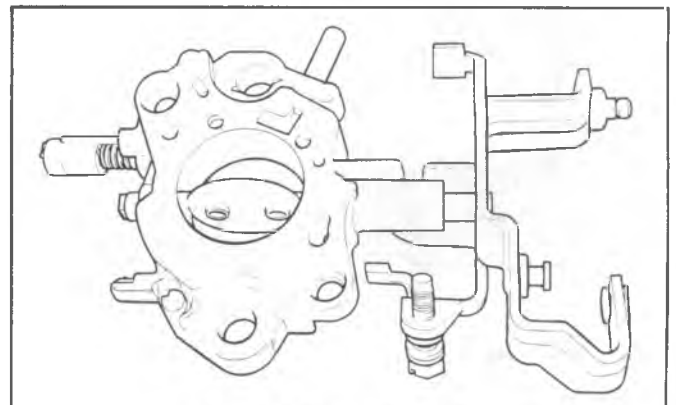

Fig. 6C1-23--Throttle Body



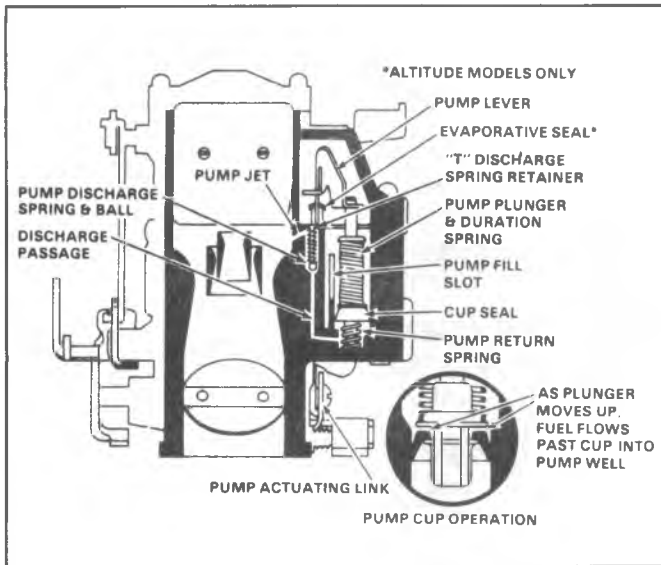

Fig. 6C1-24--Pump Drive Link

discharge hole (Fig. 6C1-21).

7. Drive pump discharge "T" in until flush with bowl casting.
8. Install accelerator pump return spring.
9. Install power piston return spring into piston cavity in the bowl.
10. Install lower end of pump link into actuator lever which fits on throttle shaft. Ends of link point toward carburetor. Bend in link faces fuel inlet nut.
11. Install curved power piston actuator link into throttle actuator lever. End protrudes outward away from throttle bore and has tang which retains link to lever.
12. Install pump plunger assembly into pump well with actuating lever protruding through bottom of bowl casting. Push downward on pump lever and install pump assembly drive link into slot in lower end of shaft. Tang on upper end of link retains link to pump shaft (Fig. 6C1-24).
13. Assembly metering rod to holder on power piston.

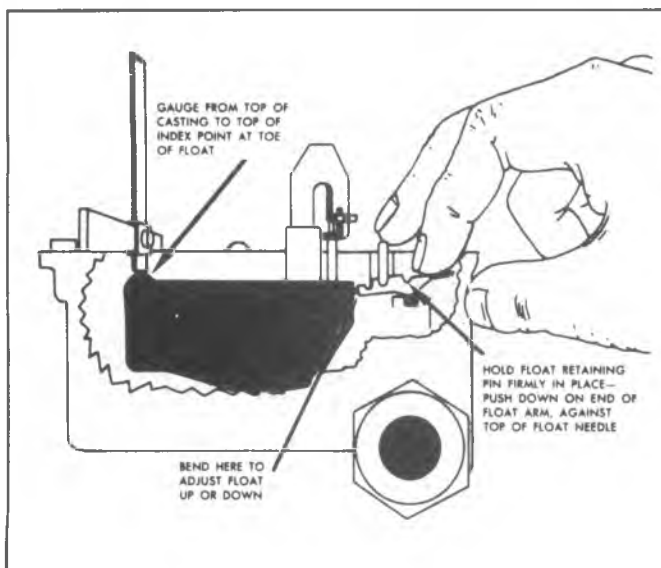

Fig. 6C1-25--Float Level Adjustment

Spring must be on top of arm when assembled correctly. Then install power piston actuating rod (right angle end) into slot in the power piston.

14. Install power piston, metering rod and drive rod assembly into the float bowl. End of drive rod must enter hole in bowl and end of metering rod into jet.
15. Before fastening power piston and pump actuator lever to end of throttle shaft, hold power piston assembly down and slide upper end of curved power piston actuator link into lower end of power piston actuating rod.
16. Install actuating lever on end of throttle shaft by aligning flats or lever with flats on shaft. Install lever retaining screw and tighten securely.
17. Install float needle valve on to float arm hooking pull clip over edge of float arm.
18. Install float hinge pin into float arm. Install float needle into seat and float with hinge pin into float bowl. Hinge pin should be in locating channels in float bowl.

#### Float Level Adjustment (Fig. 6C1-25)

1. Hold float retaining pin firmly in place push down on float arm at outer end against top of float needle, as shown.
2. Use adjustable "T" scale and measure distance from top of float at index point on toe to float bowl gasket surface (gasket removed).
3. To adjust, bend float pontoon up or down at float arm junction.

#### Metering Rod Adjustment (Fig. 6C1-26)

1. Open throttle valve, slide metering rod out of holder and remove from main metering jet.
2. To check adjustment, back out 1/8" hex screw on idle stop solenoid and rotate fast idle cam so that cam follower is not contacting steps on cam.
3. With throttle valve completely closed, apply pressure to top of power piston and hold piston down against stop.
4. Holding downward pressure on power piston, swing metering rod holder over flat surface of bowl casting next to carburetor bore.

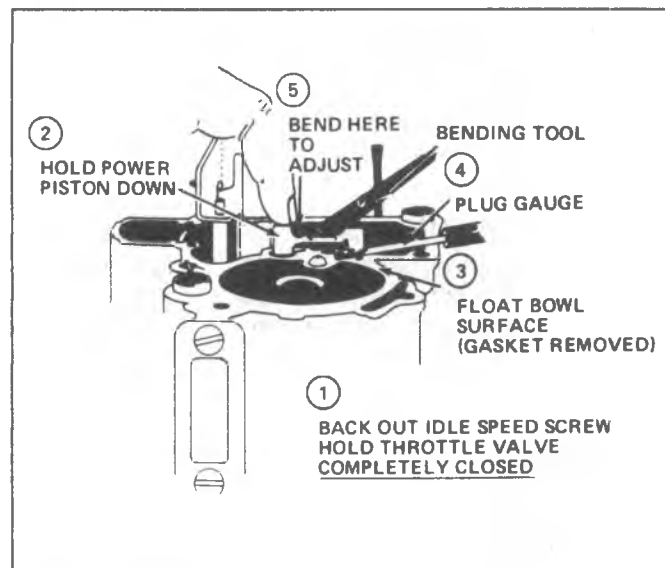

Fig. 6C1-26--Metering Rod Adjustment



Fig. 6C1-27--Installing Air Horn

5. Insert gage between bowl casting and lower surface of metering rod holder. Gage should have a slide fit between both surfaces, as shown.
6. To adjust, carefully bend metering rod holder up or down.
7. Install air horn gasket on float bowl by carefully sliding slit portion of gasket over metering rod holder. Then align gasket with dowels provided on top of bowl casting and press gasket firmly in place.

**Air Horn**

1. Install choke shaft assembly and choke valve into air horn, if removed. Align choke valve, tighten two retaining screws and stake securely in place.

**NOTICE:** Apply a torque retaining compound to the vacuum break lever retaining screw and install lever to choke shaft.

2. Install air horn to float bowl by engaging choke coil lever link into notched hole in choke coil lever on choke housing. Then carefully twist and lower air horn onto float bowl. Install three long and one short air horn to float bowl attaching screws and lockwashers (Fig. 6C1-27).
3. Install the choke vacuum break diaphragm assembly using two short air horn screws opposite the choke housing, connecting the choke vacuum break diaphragm link to slotted diaphragm plunger stem. The

two attaching screws for the choke vacuum break assembly have tapered heads for locating choke diaphragm bracket. Make sure to use these in this location. Tighten all air horn screws evenly and securely using proper tightening sequence (Fig. 6C1-28).

4. If removed, install choke housing to float bowl using three attaching screws. Two screws have lockwashers and the other one which face the choke housing has a tapered head for locating choke housing.
5. Install fast idle cam, and fast idle cam link to upper choke lever assembly. Numbers on fast idle cam face outward.
6. Install the choke cover and coil assembly in choke housing as follows:
  - a. Install the choke cover and coil assembly in the choke housing, aligning notch in cover with raised casting projection on housing cover flange. Make sure coil pick-up tang engages the inside choke coil lever.

A choke cover retainer kit is required to attach choke cover to choke housing. Install proper retainers and rivets contained in kit using suitable blind rivet installing tool. It may be necessary to use an adapter (tube) if installing tool interferes with electrical connector tower on choke cover.

Do not use a gasket between electric coil and housing, as the coil is electrically grounded through housing.

7. Install choke vacuum diaphragm hose to tube on diaphragm and connect to vacuum tube on bowl.

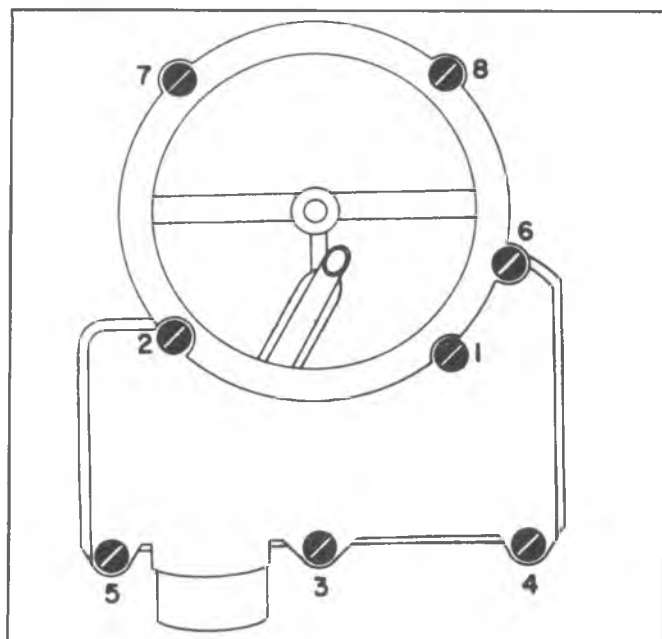
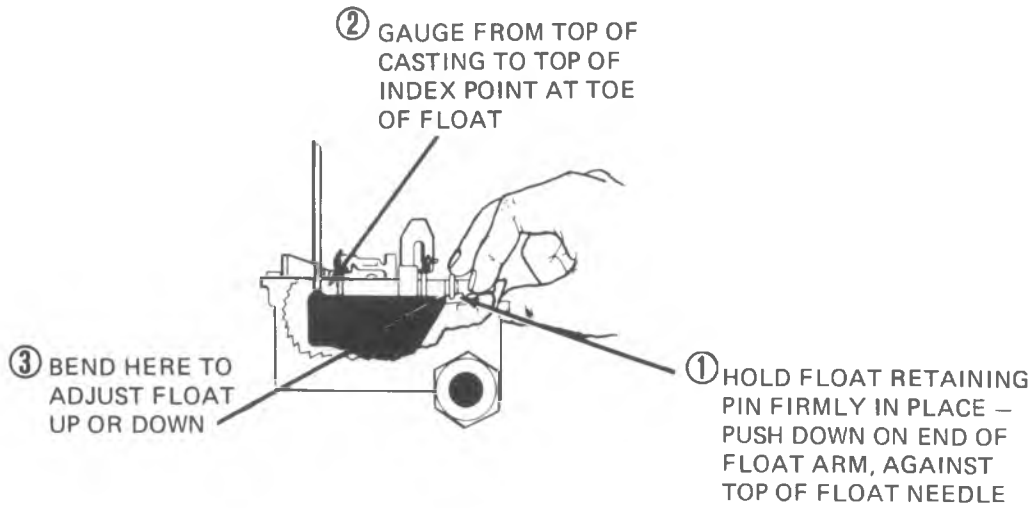
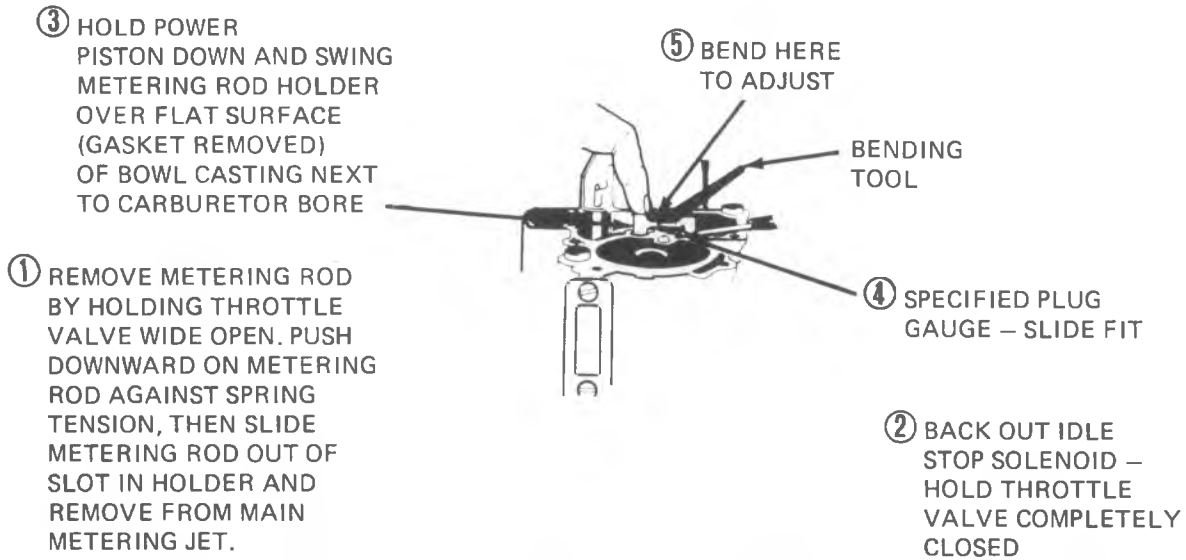

Fig. 6C1-28--Tightening Sequence

FLOAT LEVEL ADJUSTMENT



METERING ROD ADJUSTMENT



CHOKE COIL LEVER ADJUSTMENT – 1ME

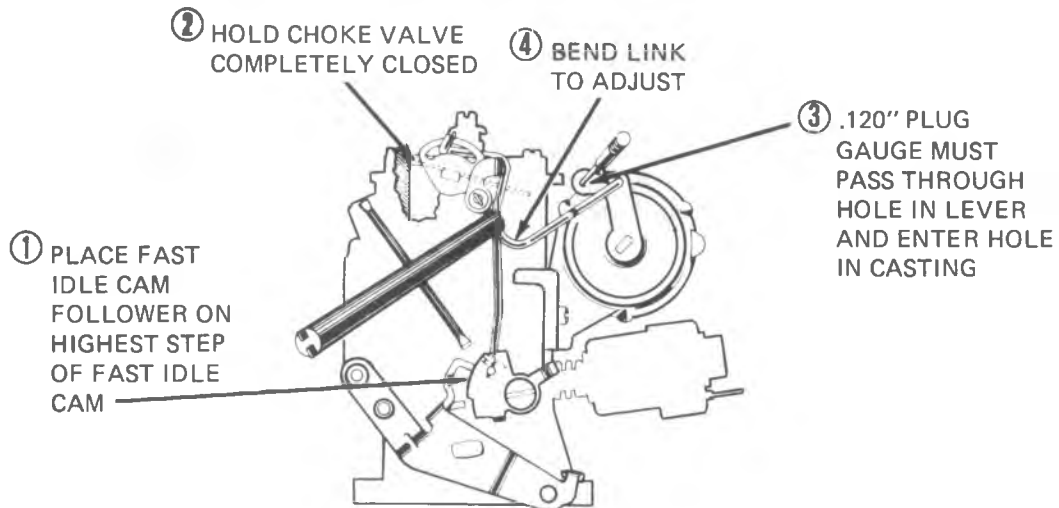
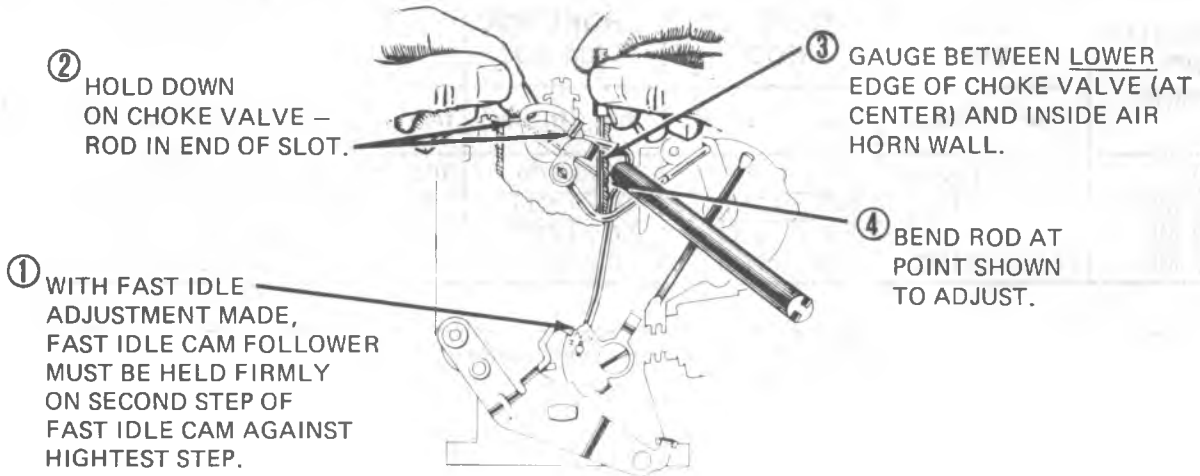
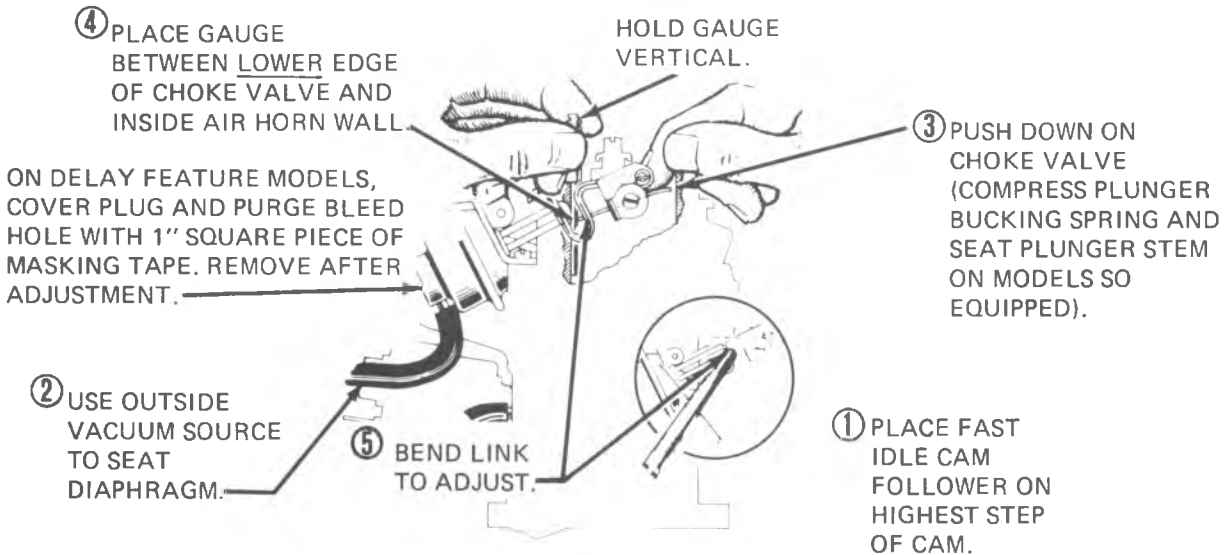

Fig. 6C1-29--1ME Adjustments (1 of 2)

**CHOKE ROD (FAST IDLE CAM) ADJUSTMENT (2ND STEP)**



**VACUUM BREAK ADJUSTMENT – 1ME (BOWL SIDE)**



**UNLOADER ADJUSTMENT – 1ME (WIDE OPEN KICK)**

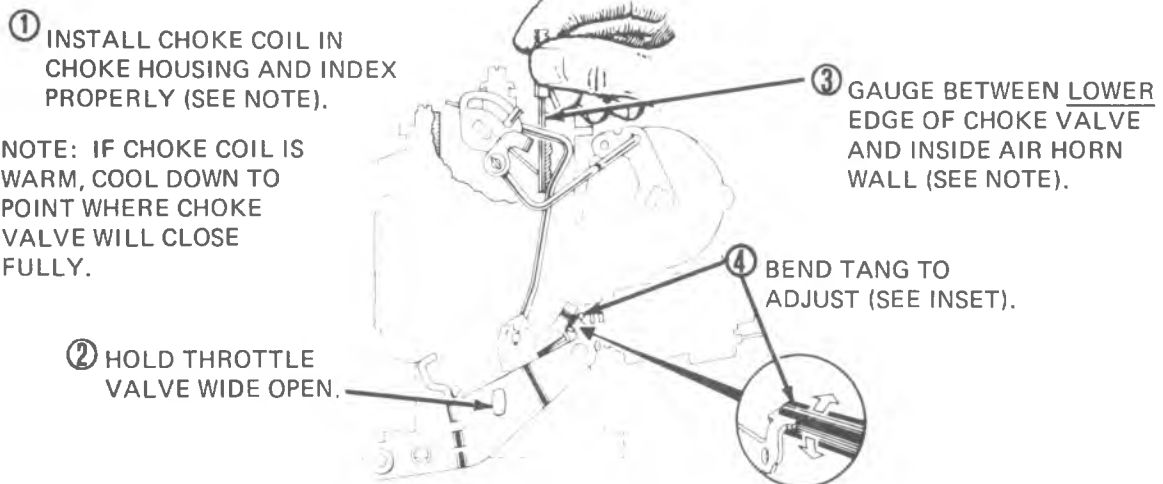

Fig. 6C1-30--1ME Adjustments (2 of 2)

## MODEL 1ME CARBURETOR ADJUSTMENT SPECIFICATIONS

| CARBURETOR<br>PART<br>NUMBER | FLOAT<br>LEVEL | METERING<br>ROD | CHOKE ROD<br>CAM ADJ | VACUUM<br>BREAK | UNLOADER      |
|------------------------------|----------------|-----------------|----------------------|-----------------|---------------|
|                              | mm / (Inches)  | mm / (Inches)   | mm/(Inches)          | mm / (Inches)   | mm/(Inches)   |
| 17080009                     | 8.7 / (11/32)  | 2.3 / (.090)    | 7.0 / (.275)         | 10.0 / (.400)   | 13.2 / (.520) |
| 17081009 ME                  | 8.7 / (11/32)  | 2.3 / (.090)    | 7.0 / (.275)         | 10.0 / (.400)   | 13.2 / (.520) |
| 17081309 ME                  | 8.7 / (11/32)  | 2.3 / (.090)    | 7.0 / (.275)         | 10.0 / (.400)   | 13.2 / (.520) |
| 17081329 ME                  | 8.7 / (11/32)  | 2.3 / (.090)    | 7.0 / (.275)         | 10.0 / (.400)   | 13.2 / (.520) |

101461

Fig. 6C1-31--1ME Adjustment Specifications

# SECTION 6C9

## CARBURETOR MODEL 2SE

### CONTENTS

|                                   |       |                                 |        |
|-----------------------------------|-------|---------------------------------|--------|
| General Description.....          | 6C9-1 | Choke and Hoses.....            | 6C9-9  |
| Diagnosis.....                    | 6C9-5 | Choke Check Procedure.....      | 6C9-9  |
| On-Vehicle Service.....           | 6C9-5 | Secondary Vacuum Break TVS..... | 6C9-9  |
| General.....                      | 6C9-5 | Carburetor Adjustments.....     | 6C9-10 |
| Carburetor Identification.....    | 6C9-5 | Unit Repair.....                | 6C9-10 |
| Float Mechanical Level Check..... | 6C9-5 | Disassembly.....                | 6C9-10 |
| Fast Idle Adjustment.....         | 6C9-5 | Cleaning and Inspection.....    | 6C9-15 |
| Idle Speed Adjustment.....        | 6C9-5 | Assembly.....                   | 6C9-15 |
| Idle Solenoid.....                | 6C9-5 | Adjustments.....                | 6C9-18 |
| Carburetor Replacement.....       | 6C9-8 | Special Tools.....              | 6C9-24 |
| Carburetor Mounting Torque.....   | 6C9-8 | Adjustment Specifications.....  | 6C9-25 |
| Fuel Filter Replacement.....      | 6C9-8 |                                 |        |

ALL NEW GM VEHICLES ARE CERTIFIED BY THE UNITED STATES ENVIRONMENTAL PROTECTION AGENCY AS CONFORMING TO THE REQUIREMENTS OF THE REGULATIONS FOR THE CONTROL OF AIR POLLUTION FROM NEW MOTOR VEHICLES. THIS CERTIFICATION IS CONTINGENT ON CERTAIN ADJUSTMENTS BEING SET TO FACTORY STANDARDS. IN MOST CASES, THESE ADJUSTMENT POINTS EITHER HAVE BEEN PERMANENTLY SEALED AND/OR MADE INACCESSIBLE TO PREVENT INDISCRIMINATE OR ROUTINE ADJUSTMENT IN THE FIELD. FOR THIS REASON, THE FACTORY PROCEDURE FOR TEMPORARILY REMOVING PLUGS, CAP, ETC., FOR PURPOSES OF SERVICING THE PRODUCT, MUST BE STRICTLY FOLLOWED AND, WHEREVER PRACTICABLE, RETURNED TO THE ORIGINAL INTENT OF THE DESIGN.

For vehicles sold in Canada and equipped with non-closed loop engines, also refer to the appropriate Canadian Service Manual Supplement.

### GENERAL DESCRIPTION

The Model 2SE carburetor is a two barrel, two stage carburetor of down-draft design.

The carburetor comprises of three major assemblies: the air horn, the float bowl and throttle body.

It has six basic operating systems (Figs. 6C9-1 to 6C9-6).

- Float
- Idle
- Main Metering
- Power
- Pump
- Choke

A single float chamber supplies fuel to both carburetor bores. A closed-cell rubber float, brass needle seat and rubber tip float valve with pull clip are used to control fuel level in the float chamber. In some cases, a float stabilizing spring has been added to further control fuel level when the vehicle is used in rugged terrain.

An air valve and metering rod control the air/fuel metering in the secondary bore of the carburetor. The

tapered metering rod is attached to the air valve, and provide the additional fuel flow necessary during increased engine air flow at wide open throttle.

The pump system uses a pump plunger and, on some models, a thermostatically controlled bypass valve to provide extra fuel during quick throttle opening. The bypass valve is pressed into the air horn casting and contains a temperature sensitive snap disk. During cold engine start-up, the pump delivers at full capacity to the primary bore of the carburetor. At normal engine operating temperatures, the bypass valve opens, allowing a portion of the fuel to be pumped back to the float bowl.

An electrically heated choke coil provides the choke valve closing force for cold start-up and for correct opening timing during warmup. Dual vacuum break units control initial choke valve opening at start up during varied ambient temperatures.

A throttle lever unloader tang forces the choke valve open to purge a flooded engine when the accelerator is pressed to the floor. A fast idle cam, following choke valve movement, acts as a graduated throttle stop to provide increased idle speed during warmup.

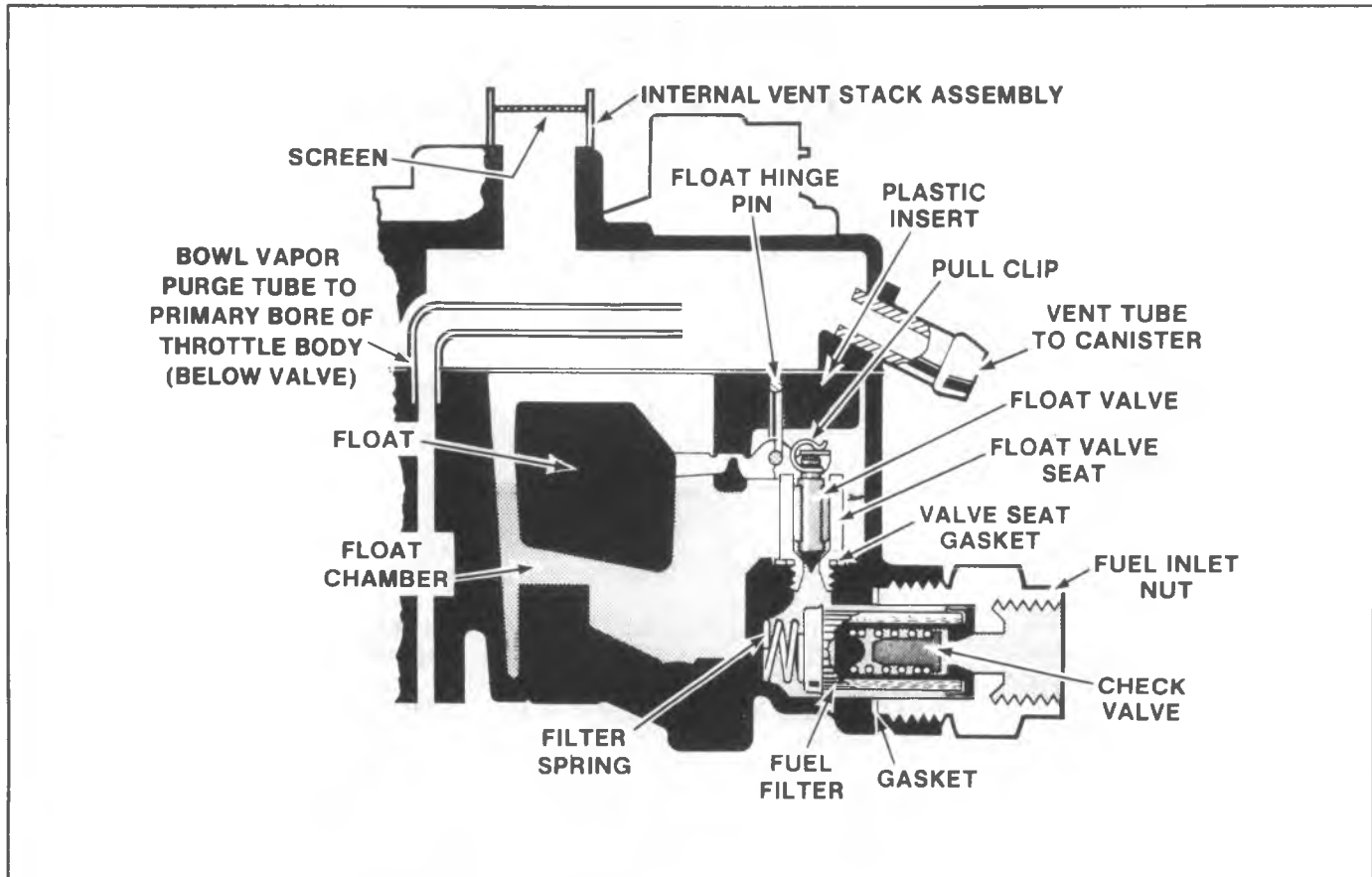

Fig. 6C9-1 Float System

On some models, a hot idle compensator valve assembly is located in the air horn casting. The opening and closing of the hot idle compensator valve is controlled by a bi-metal strip which is calibrated to a specific temperature. When the valve opens, additional air is allowed to bypass the

throttle valves, and enters the intake manifold, to prevent rough idling during periods of hot engine operation.

An Idle Speed Solenoid is used to position the primary throttle valve to provide engine idle speed requirements.

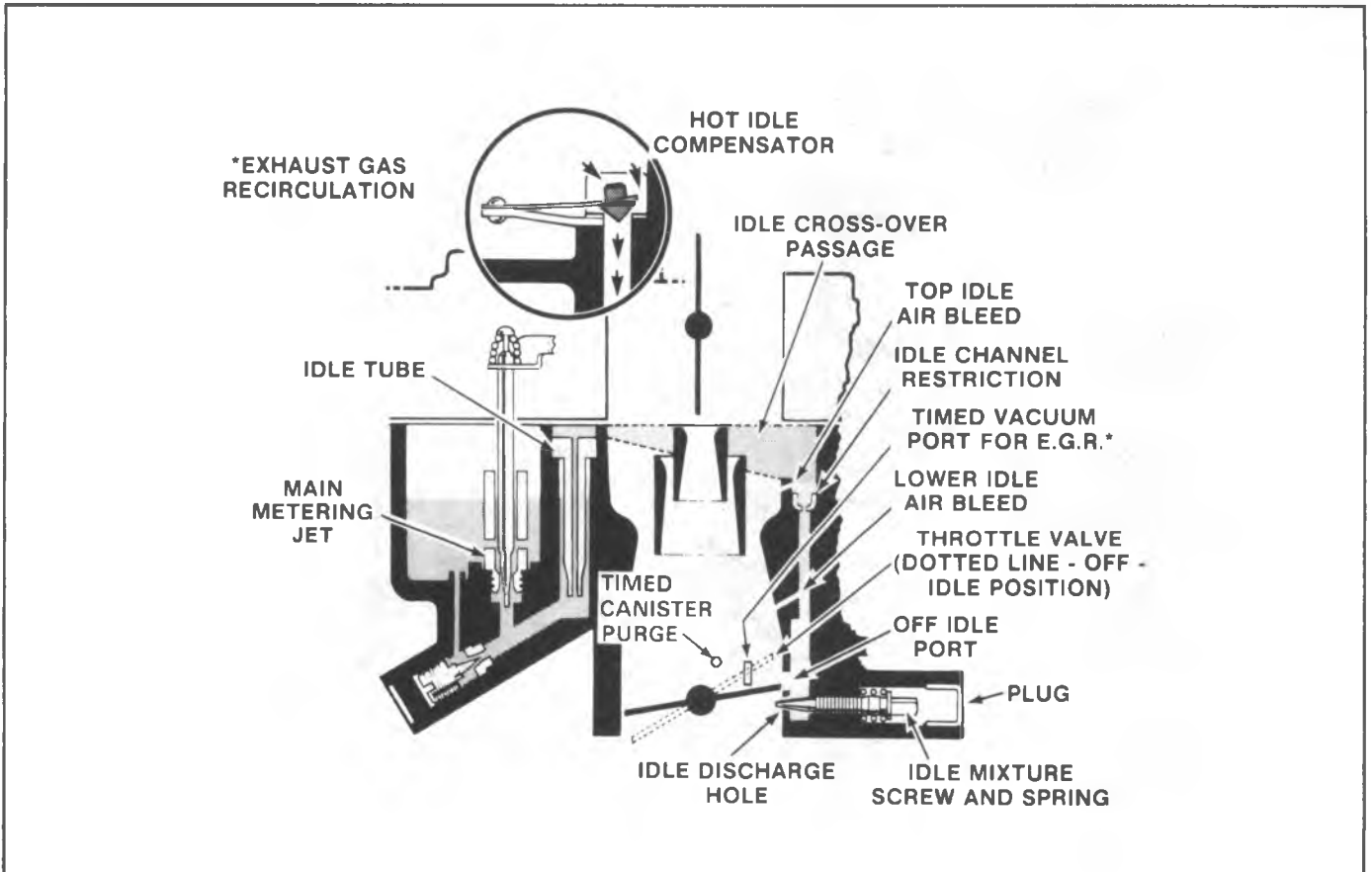

Fig. 6C9-2 Idle System

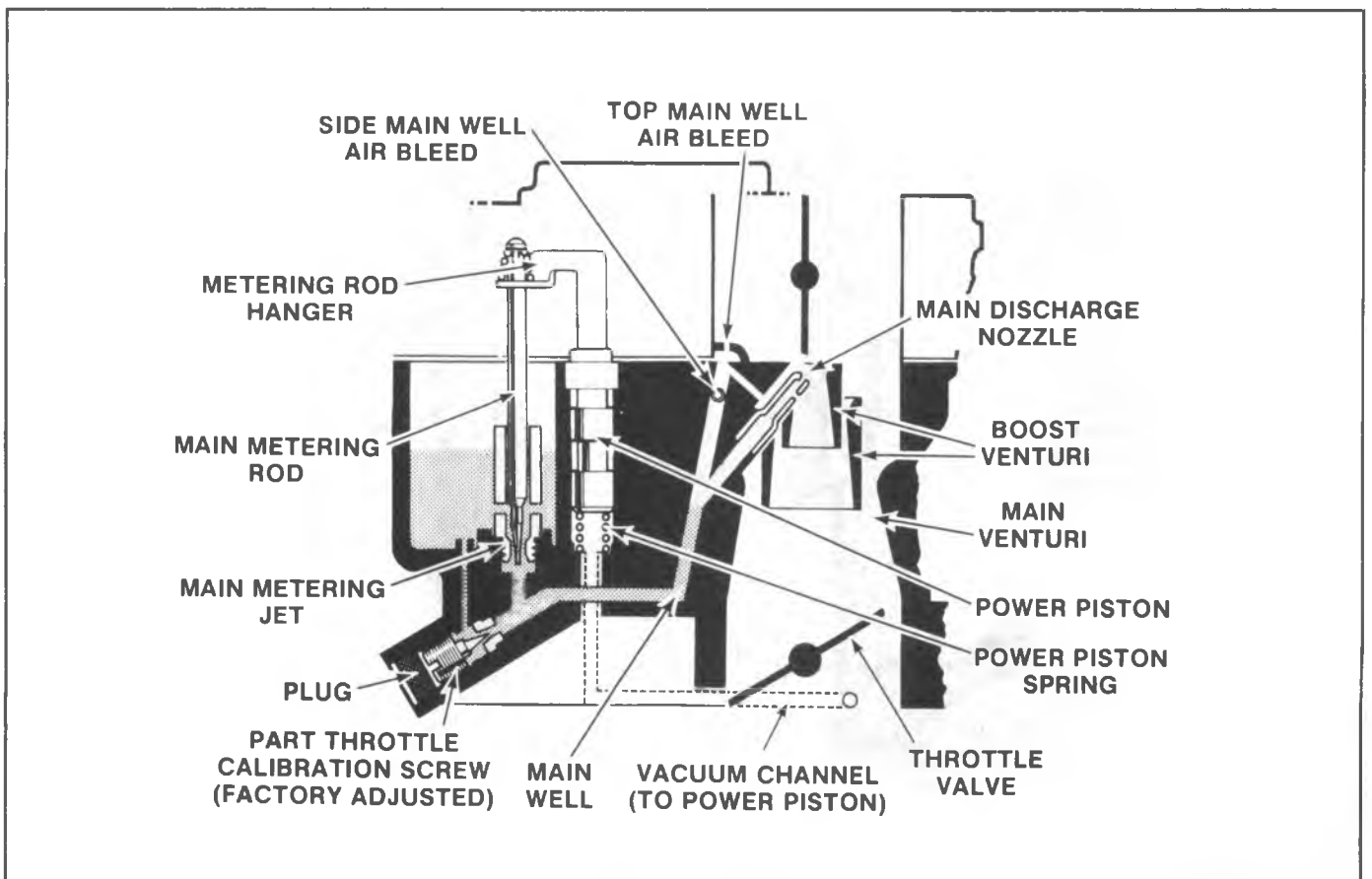

Fig. 6C9-3 Main Metering System



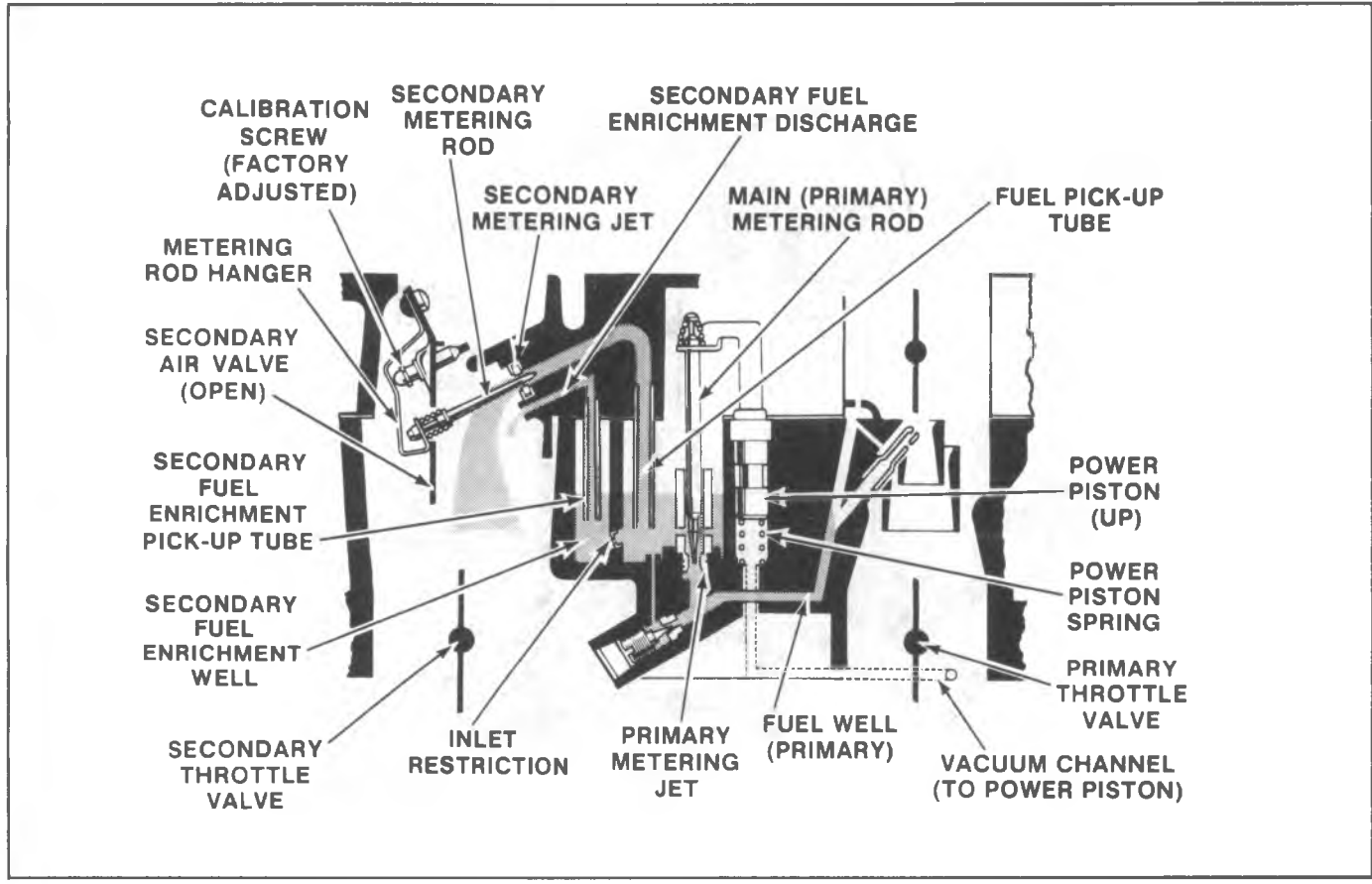

Fig. 6C9-4 Power System

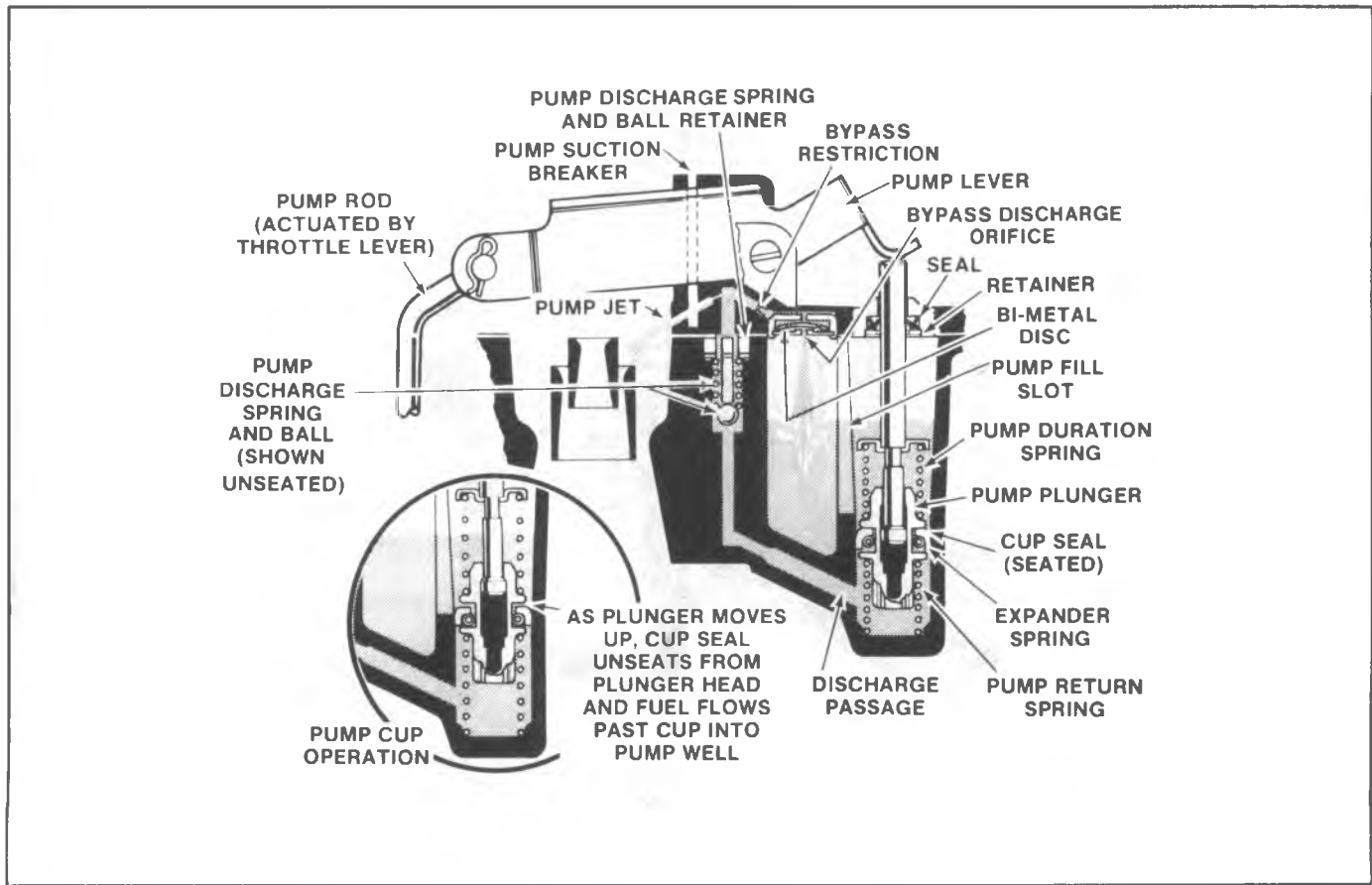

Fig. 6C9-5 Pump System

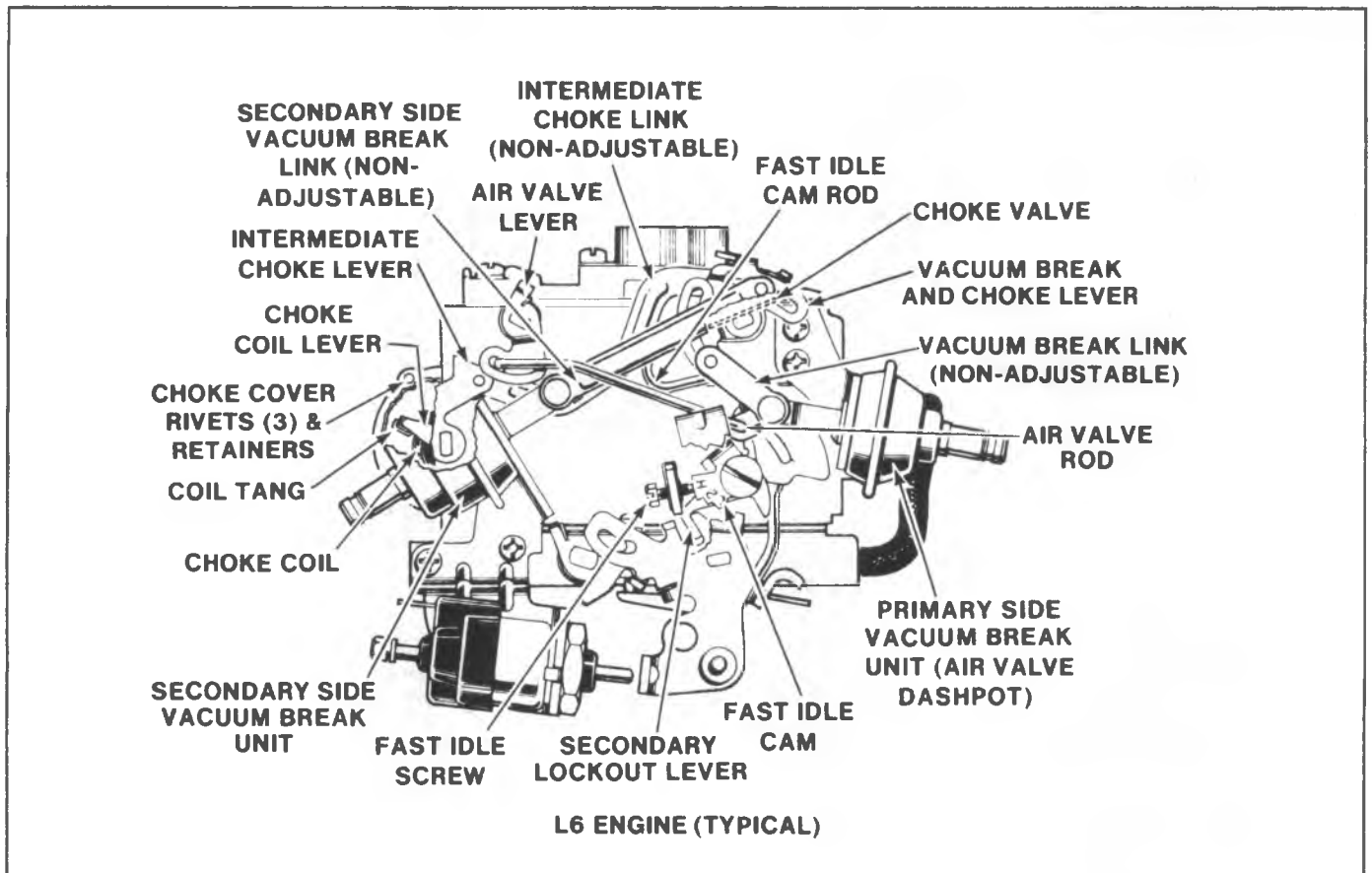

Fig. 6C9-6 Choke System

## DIAGNOSIS

Refer to Engine Performance Diagnosis (Section 6), Fuel System Diagnosis (Section 6C) and/or Cleaning and Inspection under Unit Repair in this section.

## ON-VEHICLE SERVICE

### GENERAL

Before checking or resetting the carburetor as the cause of poor engine performance or rough idle; check ignition system including distributor, timing, spark plugs and wires. Check air cleaner, evaporative emission control (EEC) system, EFE System, PCV system, EGR valve and engine compression. Also inspect intake manifold, vacuum hoses and connections for leaks and check torques of carburetor mounting bolts/nuts.

### CARBURETOR IDENTIFICATION

For ease of service, alphabetical code letters are cast into the air horn, float bowl, and throttle body castings at external tube locations to identify hose connections. The carburetor model identification is stamped vertically on the float bowl in a flat area adjacent to vacuum tube location "B" (see Figure 6C9-7). Refer to this part number when servicing the carburetor.

### FLOAT MECHANICAL LEVEL CHECK

The float level may be checked externally using tool J-9789-130 and referring to Figure 6C9-8.

### FAST IDLE ADJUSTMENT

Refer to the Vehicle Emission Control Information label and Figure 6C9-9 for fast idle adjustment.

### IDLE SPEED ADJUSTMENT

Refer to the Vehicle Emission Control Information label on the vehicle and Figure 6C9-9 for adjustment procedures and specification information.

### IDLE SOLENOID

The solenoid should be checked to assure that the solenoid plunger extends when the solenoid is energized. An inoperative solenoid could cause stalling or a rough idle when hot, and should be replaced as necessary.

#### Check

1. Turn on ignition, but do not start engine. Position transmission lever in Drive (A/T) or Neutral (M/T). On vehicles equipped with air conditioning, A/C switch must be on.
2. Open and close throttle to allow solenoid plunger to extend.

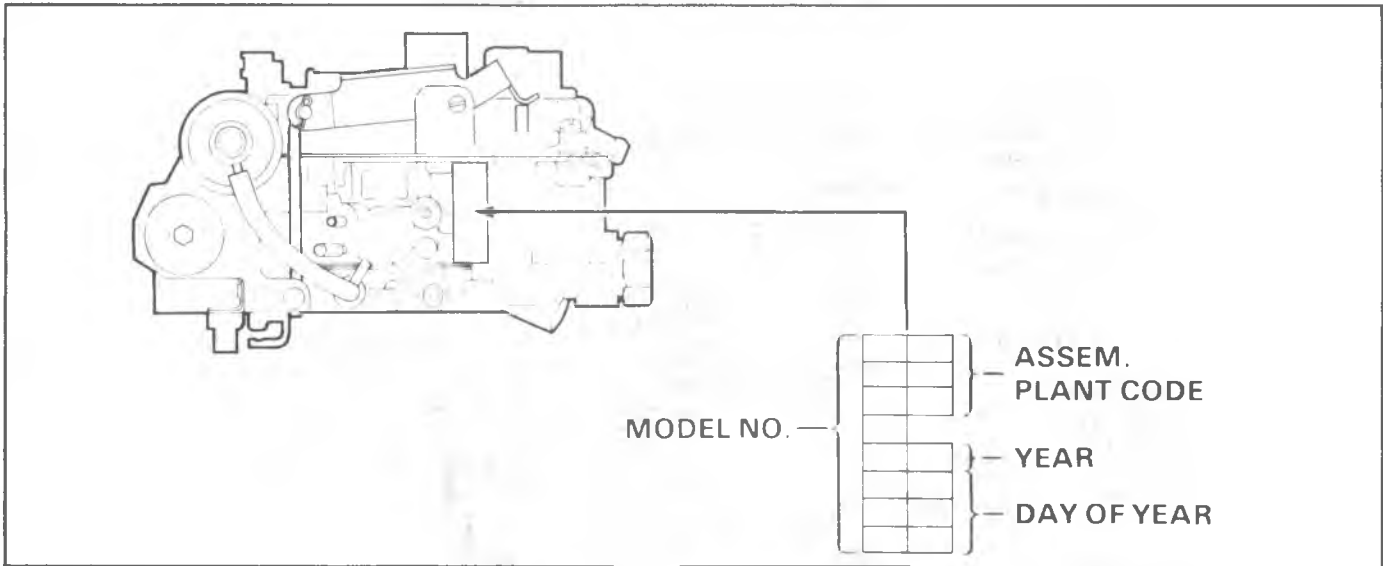

Fig. 6C9-7--Carburetor Identification

3. Disconnect wire at solenoid. Solenoid plunger should drop away from throttle lever.
4. Connect solenoid wire. Plunger should move out and contact the throttle lever. Solenoid may not be strong enough to open the throttle, but the plunger should move.
5. If plunger does not move in and out as wire is disconnected and connected, check for voltage feed wire:

- a. If voltage is 12-15 volts, replace solenoid.
- b. If voltage is low or zero, locate cause of open circuit in solenoid feed wire and repair.

**Remove**

1. Remove carburetor air cleaner.
2. Disconnect electrical connector at solenoid.
3. Remove large retaining nut, tabbed lock washer, and remove solenoid.

- ① REMOVE AIR HORN VENT STACK.
- ② SELECT CORRECT GAGE FROM BT-8104 OR J-9789-135 SERIES FOR CARBURETOR.
- ③ a USING BT-8104 GAGE SERIES, INSERT BRIDGE  
-OR-  
b USING J-9789-135 GAGE SERIES, REMOVE AIR HORN SCREW NEXT TO OPEN VENT.
- ④ WITH ENGINE RUNNING AT IDLE, CHOKE WIDE-OPEN, INSERT GAGE IN BRIDGE OR GUIDE HOLE, AND ALLOW IT TO FLOAT FREELY.

**NOTICE: DO NOT PRESS DOWN ON GAGE. FLOODING OR FLOAT DAMAGE COULD RESULT.**

- ⑤ OBSERVE AT EYE LEVEL THE MARK ON GAGE THAT LINES UP WITH TOP OF BRIDGE OR AIR HORN CASTING. SETTING SHOULD BE WITHIN  $\pm 1.588\text{mm}$  ( $1/16''$ ) OF SPECIFIED FLOAT LEVEL SETTING.  
INCORRECT FUEL PRESSURE WILL ADVERSELY AFFECT FUEL LEVEL.
- ⑥ IF NECESSARY, REMOVE AIR HORN AND ADJUST FLOAT LEVEL TO SPECIFICATION.

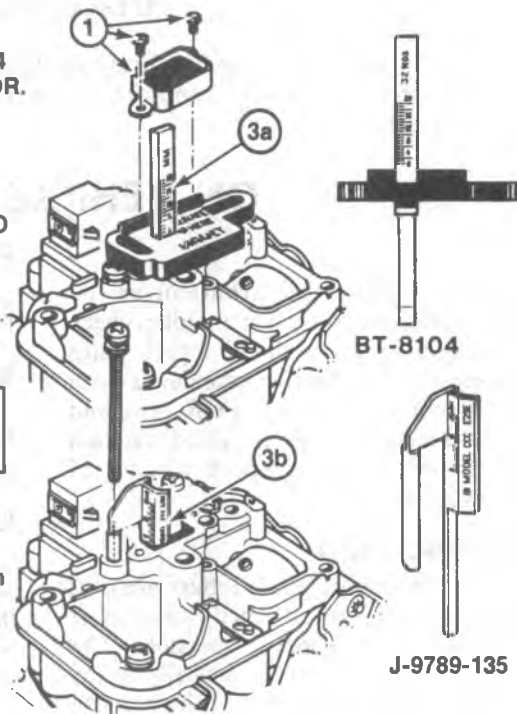

Fig. 6C9-8--External Float Check Procedure

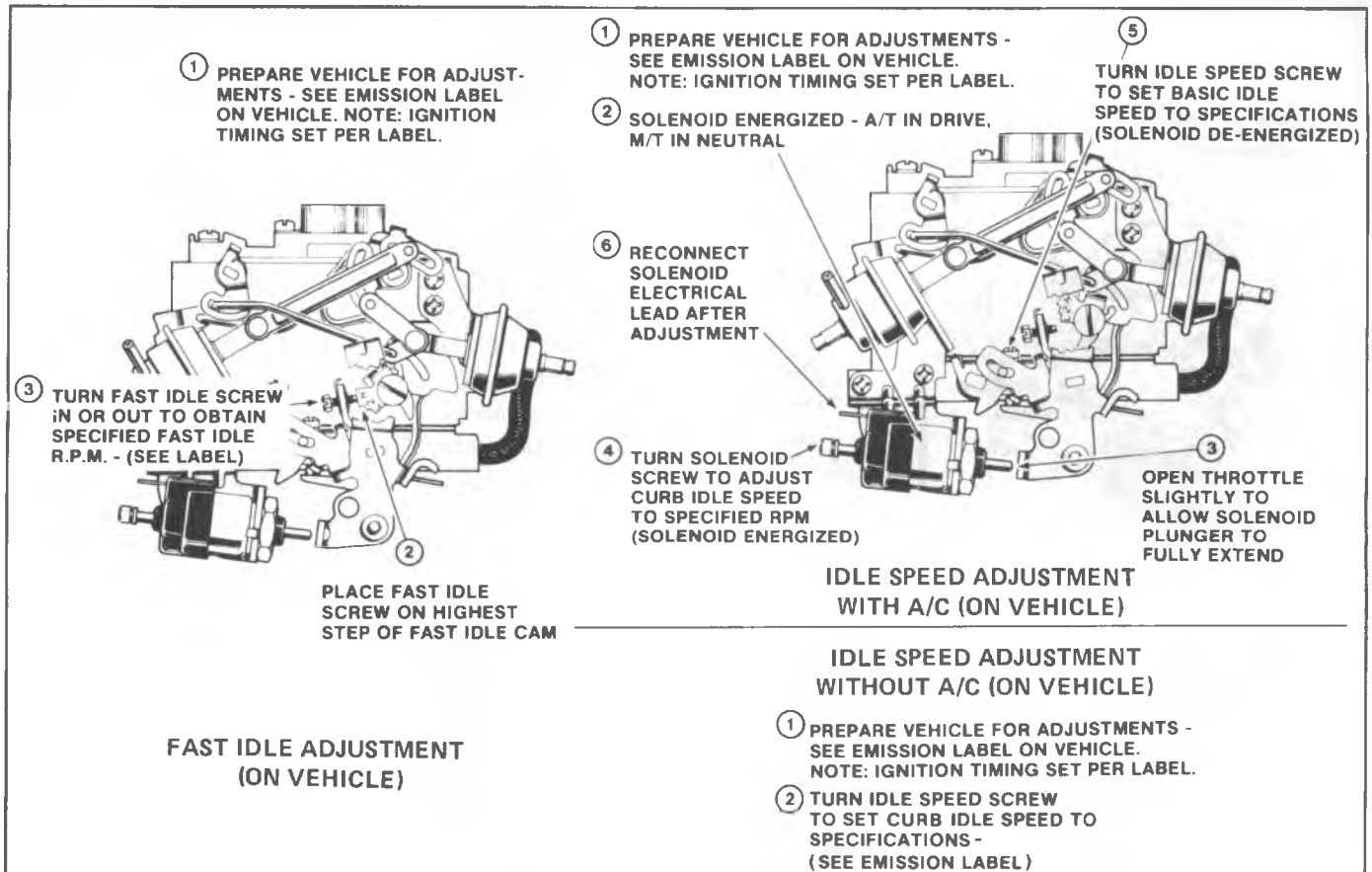

Fig. 6C9-9-2SE Carburetor On-Vehicle Speed Adjustments

**Install**

1. Install solenoid and retaining nut, bending lock tabs against nut flats.
2. Connect electrical connector.
3. Install air cleaner.
4. Refer to Vehicle Emission Control Information label, (Fig. 6C9-9) and adjust idle speed.

**IDLE MIXTURE CHECK AND ADJUSTMENT**

**Propane Enrichment**

Idle mixture screw has been preset at the factory and sealed. Idle mixture should be adjusted only in the case of major carburetor overhaul, throttle body replacement or high emissions as determined by official inspections. Adjusting mixture by other than the following method may violate Federal and/or California or other state or provincial laws.

Because of the sealed idle mixture screw, the idle mixture checking procedure requires artificial enrichment by adding propane.

1. Set parking brake and block drive wheels. Engine must be at normal operating temperature and air conditioning off.
2. Disconnect and plug hoses as directed on the Vehicle Emission Control Information label under the hood.
3. Connect an accurate tachometer to engine.

4. Disconnect vacuum advance and set timing to specification shown on the Vehicle Emission Control Information label. Re-connect vacuum advance.,
5. Set carburetor idle speed (rpm) to specification as shown on Vehicle Emission Control Information label.
6. Disconnect crankcase ventilation tube from air cleaner.
7. Using tool J-26911, insert hose with rubber stopper, from propane valve into crankcase ventilation tube opening in air cleaner. Propane cartridge must be vertical (Fig. 6C9-10).

8. With engine idling in Drive (automatic) or Neutral (Manual), slowly open propane control valve while pressing button. Continue to add propane until maximum enriched idle rpm drops due to over richness. Note maximum enriched idle rpm.

If rich rpm drop cannot be obtained, check for empty cartridge or propane system leaks.

Propane enrichment rpm is the differential between idle speed rpm and maximum idle rpm.

The maximum idle rpm is the idle rpm plus propane enrichment rpm.

9. If maximum enriched idle rpm is within specifications, the idle mixture is correct, go to Step 17.
10. If maximum enriched idle rpm is not within specifications, remove carburetor from engine to gain access to plug covering the idle mixture needle. Remove plug (Fig. 6C9-20) following procedure under Unit Repair (Throttle Body Disassembly).
11. Tightly seat mixture needle and then back out 3 turns.
12. Place transmission in Drive (automatic) or Neutral

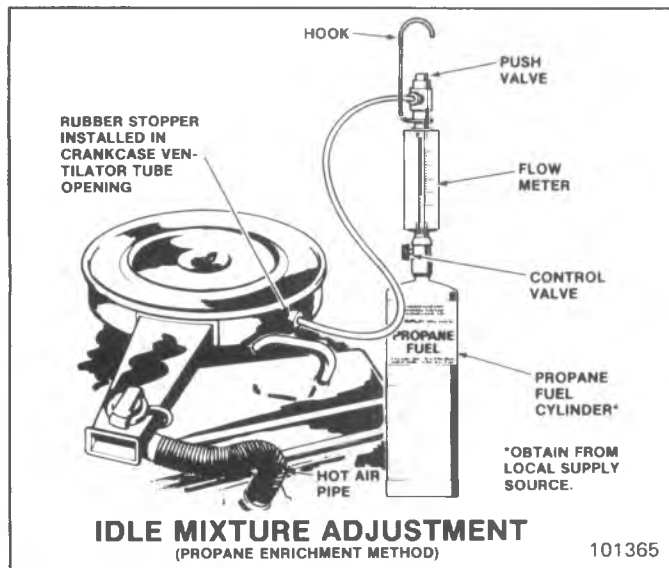

Fig. 6C9-10--Idle Mixture-Propane Enrichment

(manual).

13. Back needle out (richen 1/8 turn at a time until maximum idle speed is obtained). Then set idle speed to maximum enriched idle rpm.
14. Turn mixture needle in (clockwise) 1/8 turn at a time until idle speed reaches value given Vehicle Emission Control Information label.
15. Recheck maximum enriched rpm with propane. If not within specification, repeat adjustment beginning with Step 12.
16. Check and adjust fast idle as described on Vehicle Emission Control Information label.
17. Turn off engine. Remove propane tool, connect crankcase ventilation tube. Re-connect vacuum hoses.

## CARBURETOR REPLACEMENT (Fig. 6C9-11)

### Removal

Flooding, stumble on acceleration and other performance complaints are in many instances, caused by presence of dirt, water, or other foreign matter in carburetor. To aid in diagnosis, carburetor should be carefully removed from engine without draining fuel from bowl. Contents of fuel bowl may then be examined for contamination as carburetor is disassembled. Check fuel filter.

1. Remove air cleaner and gasket.
2. Disconnect fuel pipe and vacuum lines.
3. Disconnect electrical connectors.
5. Disconnect accelerator linkage.
6. If equipped with automatic transmission, disconnect downshift cable.
7. If equipped with cruise control, disconnect linkage.
8. Remove carburetor attaching bolts.
9. Remove carburetor and EFE heater/insulator.

### Installation

Fill carburetor bowl before installing carburetor. This reduces strain on starting motor and battery and reduces the possibility of backfiring while attempting to start engine. A

small supply of no-lead fuel will enable carburetor to be filled and the operation of the float and inlet needle and seat to be checked. Operate throttle lever several times and check discharge from pump jets before installing carburetor.

1. Inspect EFE heater/insulator for damage.  
Be certain throttle body and EFE isolator surfaces are clean.
2. Install EFE heater/insulator.
3. Install carburetor and tighten nuts alternately to correct torque (See Carburetor Mounting Torque).
4. Connect downshift cable as required.
4. Connect cruise control cable as required.
6. Connect accelerator linkage.
7. Connect electrical connections.
8. Connect fuel pipe and vacuum hoses.
9. Check base (slow) and fast idle.
10. Install air cleaner.

## CARBURETOR MOUNTING TORQUE

When torquing carburetor after removal, overhaul, replacement or when installing a new EFE heater/insulator, torque mounting bolts, in a clockwise direction, to 18 N·m (5 lbs. 45 in. lbs.).

When retorquing carburetor at recommended maintenance intervals, check in a clockwise direction. If less than 9 N·m (80 in. lbs.), retorque to 13 N·m (110 in. lbs.); if greater than 9 N·m (80 in. lbs.), do not retorque.

## FUEL FILTER REPLACEMENT

A plugged fuel filter will restrict fuel flow into carburetor and will result in a loss of engine power.

1. Remove air cleaner.
2. Disconnect fuel line connection at inlet fuel filter nut.
3. Remove inlet fuel filter nut from carburetor.
4. Remove filter and spring (Figure 6C9-12).
5. Install spring and filter element in carburetor with hole in filter toward nut.
6. Install new gasket on inlet fitting nut and install nut in carburetor and tighten to 34 N·m (300 in.

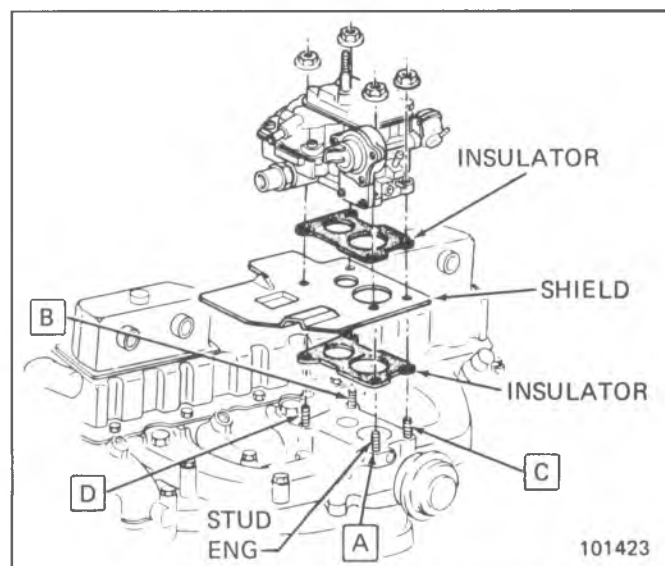

Fig. 6C9-11--Carburetor Replacement

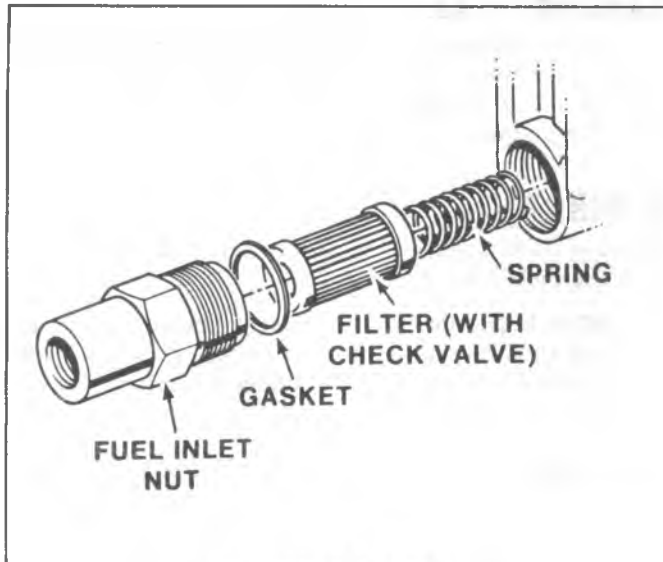

Fig. 6C9-12--Fuel Filter

lbs.).

7. Install fuel line and tighten connector to 24 N·m (18 ft. lbs.) while holding fuel inlet fitting with wrench.
8. Run engine and observe for leaks.

### CHOKE AND HOSES

Check choke mechanism and vacuum break for proper operation at the recommended maintenance intervals. Any binding condition which may have developed due to petroleum gum formation on the choke shaft or from damage should be corrected. Check carburetor hoses for proper connection, cracking, abrasion or deterioration and correct or replace as necessary.

### CHOKE CHECK PROCEDURE

1. Remove air cleaner. With engine off, hold throttle half open. Open and close choke several times. Watch linkage to be certain all links are connected and there are no signs of damage.
2. If choke or linkage binds, sticks or works sluggishly, clean with Delco Choke Cleaner X-20-A or equivalent. Use cleaner as directed on can. If cleaning does not correct, replace binding parts.
3. Visually inspect carburetor to be certain all vacuum hoses are connected. Inspect hoses for cracks, abrasion, hardness or signs of deterioration. Replace or correct as necessary.
4. Make sure vacuum break diaphragm shafts are fully extended when engine is off. If shafts are not fully extended, replace vacuum break assembly. Start engine, primary vacuum break diaphragm shaft should fully retract. If unit fails to retract, replace vacuum break assembly.

### Checking Electric Choke

If the electric choke fails, the following checks should be made:

1. Check voltage at the choke heater connection with the engine running. If voltage is between 12 and 15 volts, replace the electric choke unit.
2. If the voltage is low or zero, check all wires and connections.

3. If steps 1 and 2 are OK, check the following:

- Gage equipped vehicles - See Section 8A for Choke Heater Circuit Diagnosis.
- Non-gage equipped vehicles - if the connection at the oil pressure switch is faulty, the temperature/pressure warning light will be off with the ignition key "on" and the engine not running. Repair wires as required. If choke is still inoperative, replace oil pressure switch.

### CHOKE COIL REPLACEMENT

Choke mechanism should be checked for free operation. A binding condition may have developed from petroleum gum formation on the choke shaft or from damage. Choke shafts can usually be cleaned without disassembly.

1. Remove air cleaner and disconnect choke electrical connector.
2. Align a #21 drill (.159") on rivet head and drill only enough to remove rivet head (Fig. 6C9-19). After removing rivet heads and retainers, use a drift and small hammer to drive the remainder of the choke housing. Use care in drilling to prevent damage to the choke cover or housing. Remove the three retainers and choke cover assembly from choke housing.
3. Remove choke coil from housing.
4. Install the choke cover and coil assembly in choke housing as follows:

Install the choke cover and coil assembly in the choke housing, aligning notch in cover with raised casting projection on housing cover flange. Make sure coil pick-up tang engages the inside choke coil lever.

A choke cover retainer kit is required to attach the choke cover to the choke housing. Install proper retainers and rivets contained in kit using a suitable blind rivet installing tool.

5. Connect choke electrical connector.
6. Start engine, check operation of choke and then install air cleaner.

### SECONDARY VACUUM BREAK THERMAL VACUUM SWITCH (TVS)

The secondary vacuum break TVS, located in the air cleaner, improves cold starting and cold driveability by sensing carburetor air inlet temperature to control the carburetor secondary vacuum break.

#### Replacement

1. Remove air cleaner cover and element.
2. Disconnect vacuum hoses.
3. Pry clip from TVS and remove TVS.
4. Install new TVS and replace clip.
5. Reconnect vacuum hoses (refer to Vehicle Emission Control Information label).
6. Install air cleaner cover and element.

### SECONDARY VACUUM BREAK TVS CHECK

1. With engine at normal operating temperature, the Thermal Vacuum Switch (TVS) must be open (air cleaner cover on).
2. Apply either engine or auxiliary vacuum to the

inlet port and check for vacuum at the outlet port (outlet port connects to secondary vacuum break).

3. If there is no vacuum, check thermostatic air cleaner vacuum hoses and/or replace the TVS.

## UNIT REPAIR

In many cases, necessary service procedures can be performed without removing the carburetor from the engine. Adjustments of individual systems, for example, will be found in previous "On Vehicle Service" information.

The information that follows pertains to a complete overhaul of the carburetor, following removal from the engine. Complete overhaul includes: disassembly, thorough cleaning, inspection, and replacement of all gaskets, seals, worn or damaged parts, and adjustment of individual systems.

Refer to Figures 6C9-13 and 6C9-14 for identification of individual parts and for disassembly and assembly of carburetor components.

**NOTICE:** Before performing any service on the carburetor, it is essential that it be placed on a holding fixture, such as Tool J-9789-118A or BT-30-15. Without the use of the holding fixture, it is possible to damage throttle valves.

The primary and secondary throttle shafts, the secondary actuating lever and lockout lever, are coated with a special material to reduce friction and wear on these operating parts. Also, the secondary throttle bore and valve are coated with a special graphite compound for minimum air leakage past the valve for good idle air control. Care should be taken during carburetor service to not disturb or damage these coatings.

## DISASSEMBLY

### IDLE SPEED SOLENOID/PRIMARY VACUUM BREAK

#### Removal

1. Remove primary vacuum break hose.
2. Remove attaching screws holding the idle speed solenoid/primary vacuum break bracket to the throttle body.
3. Remove the bracket assembly. Disengage the vacuum break link ("T" pin) from the slot in the choke lever. Lift and rotate the bracket assembly to remove the air valve rod from the slot in the air valve lever.

**NOTICE:** Do not immerse the idle speed solenoid or vacuum break unit in any type of carburetor cleaner. These parts must always be removed before complete cleaning or overhaul, to avoid internal damage.

### SECONDARY VACUUM BREAK

#### Removal

Remove the attaching screws holding the vacuum break and bracket assembly to the throttle body. Rotate the

## CARBURETOR ADJUSTMENTS

The remaining carburetor adjustments are part of Unit Repair. These adjustments, in most cases, may be performed on the vehicle. Refer to Figures 6C9-27 through 6C9-37 for adjustment procedures.

assembly to disengage the vacuum break link ("T" pin) from the choke lever slot.

**NOTICE:** Do not immerse vacuum break unit in any type of carburetor cleaner. This part must always be removed before complete cleaning or overhaul, to avoid internal damage.

## AIR HORN

### Removal

1. Remove the clip from the hole in the pump rod.

**NOTICE:** Do not remove pump lever retaining screw nor pump lever from the air horn assembly.

2. Remove and discard the retaining clip from the intermediate choke rod at the choke lever. A new clip is required for reassembly. Remove choke rod and the plastic bushing from the choke lever, (Fig. 6C9-15). Save for reassembly.
3. If a hot idle compensator valve is used, remove the two small attaching screws holding the valve to the air horn. Remove the valve and seal from the air horn. Discard the seal. The hot idle compensator valve must be removed to gain access to the short air horn-to-bowl attaching screw.
4. Remove the seven air horn-to-bowl attaching screws and lockwashers.
5. Rotate the fast idle cam to its highest position. Remove the air horn assembly by tilting it to disengage the fast idle cam rod from the slot in the fast idle cam, also the pump rod from the hole in the pump lever. If the pump plunger comes out of the float bowl during air horn removal, remove the plunger. The air horn gasket should remain on the float bowl for later removal.

On some models, the fast idle cam rod is attached to the fast idle cam by a retaining clip and a plastic bushing. If used, remove and discard both the retaining clip and plastic bushing from the fast idle cam rod at the fast idle cam. A new clip and bushing will be required for reassembly.

Do not remove the fast idle cam screw and cam from the float bowl. These parts are not serviced separately, and remain in place as installed at the factory. The replacement float bowl, if required, will include the secondary lockout lever, fast idle cam and screw installed.

6. Remove the fast idle cam rod from the choke lever by rotating rod to align the "squirt" on the rod with the small slot in the lever.



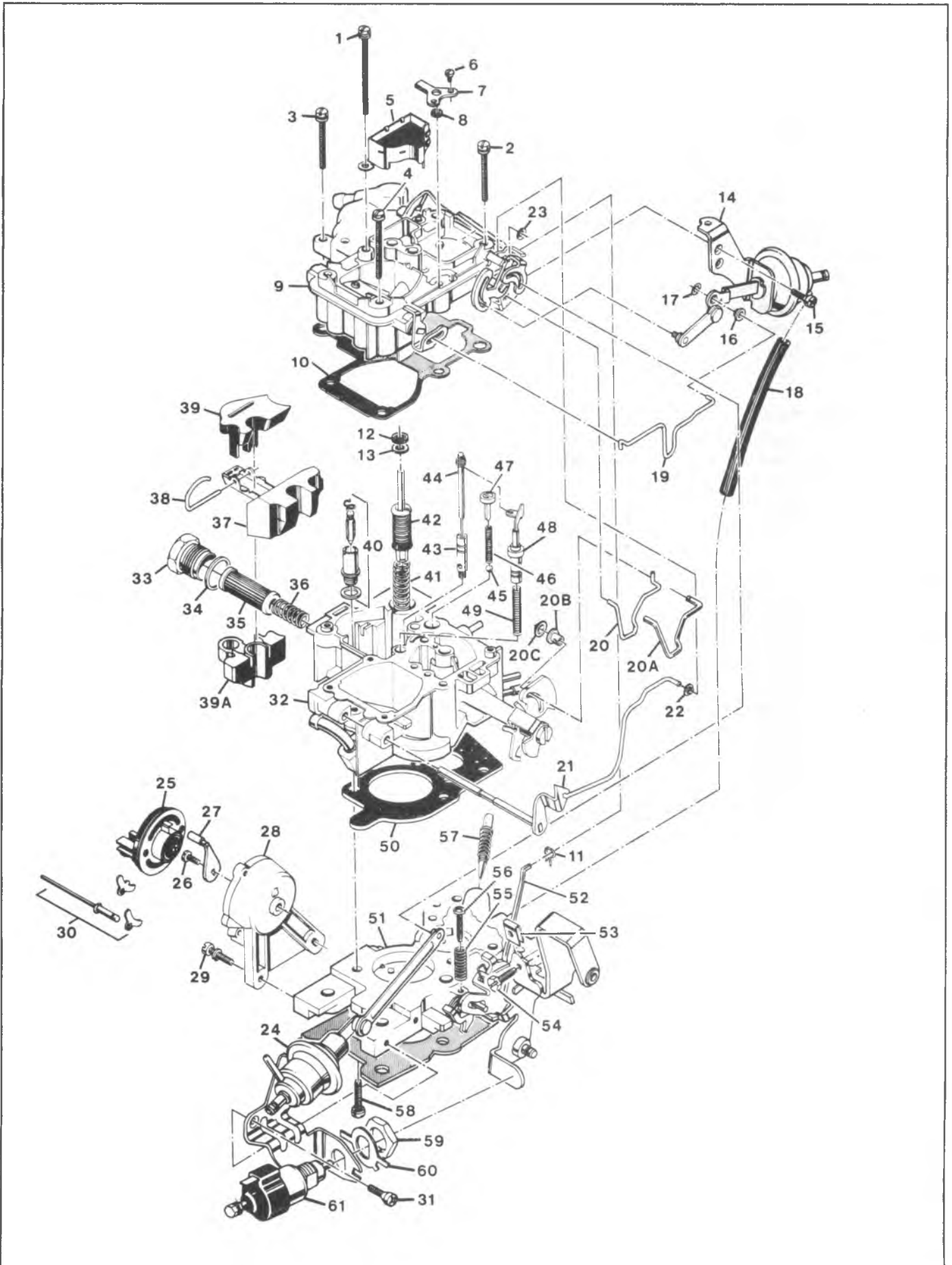

Fig. 6C9-13-- 2SE Carburetor Assembly



**AIR HORN PARTS**

- 1 - Screw - Air Horn (Long) (2)
- 2 - Screw - Air Horn (Large)
- 3 - Screw - Air Horn (Short) (3)
- 4 - Screw - Air Horn (Medium)
- 5 - Vent Stack Assembly
- 6 - Screw - Hot Idle Compensator (2)
- 7 - Hot Idle Compensator
- 8 - Gasket - Hot Idle Compensator
- 9 - Air Horn Assembly
- 10 - Gasket - Air Horn
- 11 - Retainer - Pump Link
- 12 - Seal - Pump Stem
- 13 - Retainer - Stem Seal

**CHOKE PARTS**

- 14 - Vacuum Break and Bracket Assembly - Primary
- 15 - Screw - Vacuum Break Attaching
- 16 - Bushing - Air Valve - Link
- 17 - Retainer - Air Valve Link
- 18 - Hose - Vacuum Break - Primary
- 19 - Link - Air Valve
- 20 - Link - Fast Idle Cam
- 21 - Intermediate Choke Shaft/Lever/Link Assembly
- 22 - Bushing - Intermediate Choke Shaft Link
- 23 - Retainer - Intermediate Choke Shaft Link
- 24 - Vacuum Break and Bracket Assembly - Secondary
- 25 - Choke Cover and Coil Assembly
- 26 - Screw - Choke Lever
- 27 - Choke Lever and Contact Assembly
- 28 - Choke Housing
- 29 - Screw - Choke Housing (2)
- 30 - Stat Cover Retainer Kit
- 31 - Screw - Vacuum Break Attaching (2)

**FLOAT BOWL PARTS**

- 32 - Float Bowl Assembly
- 33 - Nut - Fuel Inlet
- 34 - Gasket - Fuel Inlet Nut
- 35 - Filter - Fuel Inlet
- 36 - Spring - Fuel Filter
- 37 - Float Assembly
- 38 - Hinge Pin - Float
- 39 - Insert - Float Bowl
- 40 - Needle and Seat Assembly
- 41 - Spring - Pump Return
- 42 - Pump - Assembly
- 43 - Jet - Main Metering
- 44 - Rod - Main Metering Assembly
- 45 - Ball - Pump Discharge
- 46 - Spring - Pump Discharge
- 47 - Retainer - Pump Discharge Spring
- 48 - Power Piston Assembly
- 49 - Spring - Power Piston

**THROTTLE BODY PARTS**

- 50 - Gasket - Throttle Body
- 51 - Throttle Body Assembly
- 52 - Pump Rod
- 53 - Clip - Cam Screw
- 54 - Screw - Cam
- 55 - Spring - Throttle Stop Screw
- 56 - Screw - Throttle Stop
- 57 - Idle Needle and Spring
- 58 - Screw - Throttle Body Attaching (4)
- 59 - Nut - Idle Solenoid
- 60 - Retainer - Idle Solenoid
- 61 - Idle Solenoid

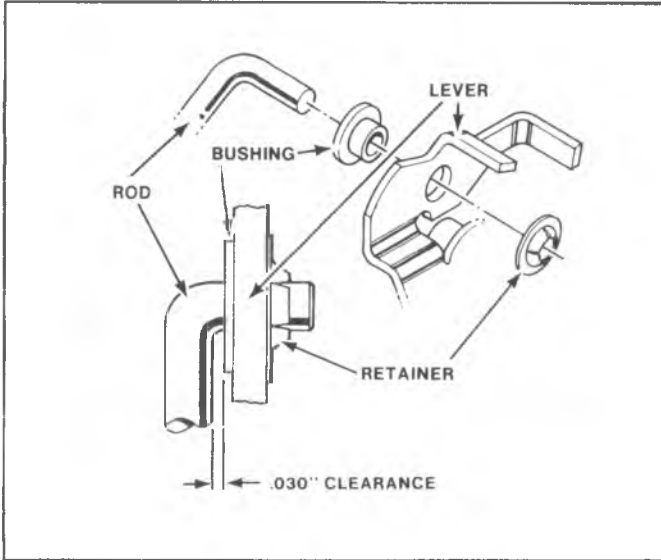

Fig. 6C9-15--Intermediate Choke Linkage

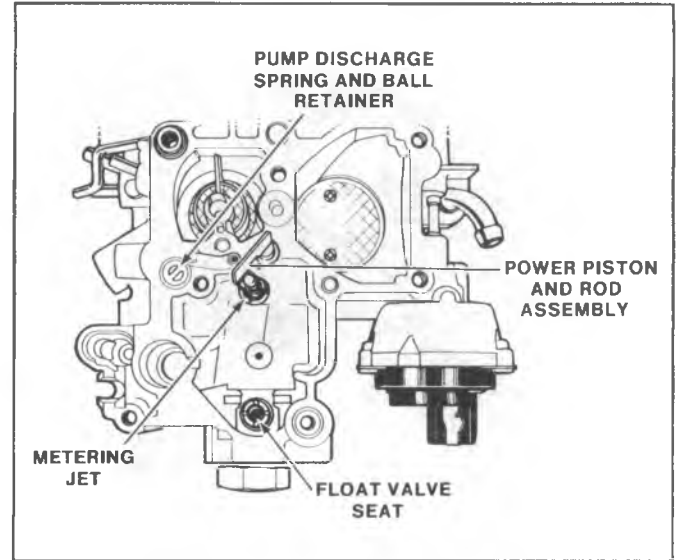

Fig. 6C9-17--Float Bowl Assembly

**AIR HORN**

**Disassembly**

1. To remove the pump plunger stem seal (Fig. 6C9-16), invert the air horn and use a small screwdriver to remove the staking holding seal retainer in place. Remove the retainer and seal, and discard.

**NOTICE:** Use care in removing pump plunger stem seal retainer to prevent damage to air horn casting. New seal and retainer are required for reassembly.

2. Remove the vent screen assembly by removing the two small attaching screws.
3. Further disassembly of the air horn is not required for cleaning purposes or air horn replacement. If required, a new service air horn assembly includes the secondary metering rod-air valve assembly, already set to factory specifications. No attempt should be made to change air valve settings. The air valve and choke valve attaching screws are staked in place and are not removable. The thermostatic pump bypass assembly in the service

air horn is pressed permanently in place at the factory and is not serviced separately.

**FLOAT BOWL**

**Disassembly**

1. Remove air horn gasket. Gasket is pre-cut for easy removal around the metering rod and hanger assembly.
2. Remove pump plunger from pump well, if not removed with air horn.
3. Remove pump return spring from pump well.
4. Remove upper plastic filler block over float valve.
5. Remove float assembly and float valve by pulling up hinge pin (holding float clip in place with finger while tilting float to clear bowl vapor purge tube). When a float stabilizing spring is used, remove spring with the float assembly and float valve. Remove lower plastic filler block, if used.
6. Remove float valve seat and gasket using a wide blade screwdriver (Fig. 6C9-17).

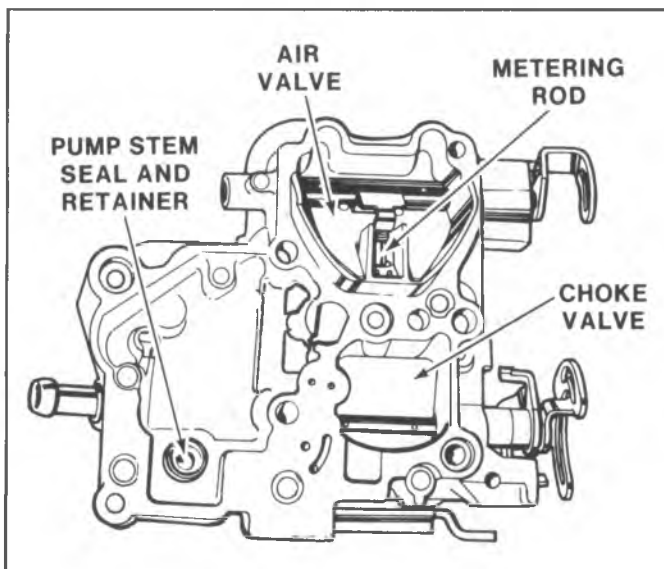

Fig. 6C9-16--Air Horn Assembly

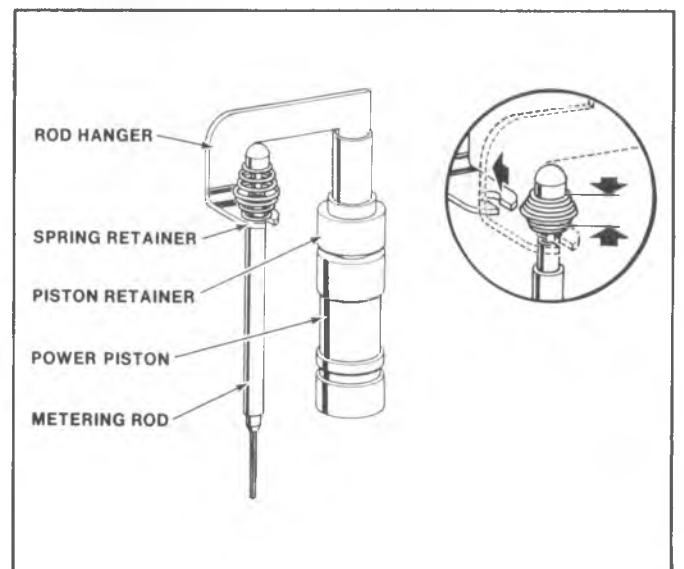

Fig. 6C9-18--Power Piston and Metering Rod Assembly

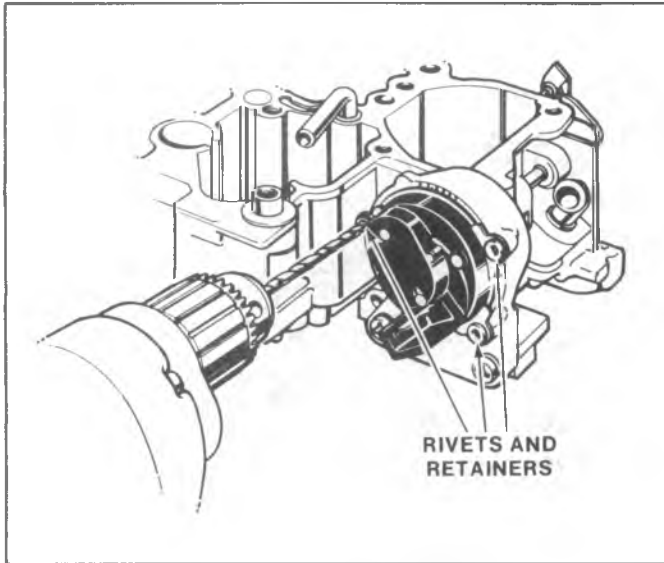

Fig. 6C9-19--Choke Cover Removal

7. Remove power piston and metering rod assembly by depressing piston stem and allowing it to snap free. This will cause the power piston spring to snap the piston up against the plastic retainer (Fig. 6C9-18). This procedure may have to be repeated several times. Do not remove power piston by using pliers on metering rod holder.
8. Remove the power piston spring from the piston bore. If necessary, the metering rod may be removed from the power piston hanger by compressing the spring on top of the metering rod, and aligning the groove of the rod with the slot in the holder (Fig. 6C9-18). Be careful in handling the metering rod to prevent damage to the metering rod tip.
9. Remove the main metering jet using a wide bladed screwdriver.
10. Use small slidehammer or equivalent to remove plastic retainer holding the pump discharge spring and check ball in place. Discard plastic retainer. A new retainer is required for reassembly.

Invert bowl, catching pump discharge spring and check ball as they fall from bowl. Return bowl to normal position.

**NOTICE:** Do not attempt to remove plastic retainer by prying with a tool such as a punch or screwdriver, as prying will damage the sealing beads on the bowl casting surface and will require complete float bowl replacement.

9. Remove fuel inlet nut, gasket, check valve filter assembly and spring. Discard gasket and filter.

## CHOKE

### Disassembly

A tamper-resistant choke cover design discourages unnecessary readjustment of the choke thermostatic cover and coil assembly in the field. However, if it is necessary to remove the cover and coil assembly during routine carburetor disassembly for cleaning and overhaul, proceed as follows:

### Choke Cover Removal

1. Use a suitable holding fixture to support float bowl and throttle body as an assembly.
2. Carefully align a 4mm (.159")-drill on rivet head, and drill only enough to remove rivet head, (Fig. 6C9-19). Remove rivet heads and retainers. Use a drift and small hammer to drive the remainder of the rivets out of the choke housing.

**NOTICE:** Use care in drilling, to prevent damage to choke cover or housing.

3. Remove screw from end of intermediate choke shaft inside choke housing. Remove choke coil lever from end of shaft.
4. Remove intermediate choke shaft assembly from float bowl by sliding shaft to rear and out the throttle lever side.
5. Remove choke housing by removing two attaching screws.

## THROTTLE BODY

### Removal

1. Remove four throttle body-to-float bowl attaching screws, and remove throttle body assembly from float bowl.
2. Remove throttle body gasket.

### Disassembly

1. Place throttle body assembly on suitable carburetor holding fixture to avoid damage to throttle valves.
2. Hold primary throttle lever in wide open position, and remove pump rod from throttle lever after rotating rod until "squirt" on rod aligns with slot in lever. Further disassembly of the throttle body is not required for cleaning purposes.

**NOTICE:** The primary and secondary throttle valve screws are staked in place and should not be removed. The throttle body is serviced as a complete assembly.

3. DO NOT remove the plug covering the idle mixture needle unless normal soaking in cleaner and blowing with shop air fails to clean the idle mixture passages. If necessary, remove the idle mixture plug and needle (Fig. 6C9-20) as follows:
  - a. Invert throttle body and place on suitable holding fixture, (manifold side up).
  - b. Make two parallel cuts in the throttle body, one on each side of the locator point, with a hacksaw. Cuts should reach down to the steel plug, but should not extend more than 1/8" (3.2mm) beyond the locator point. Distance between saw cuts depends on the size of the punch to be used.
  - c. Place a flat punch at a point near the ends of the saw marks in the throttle body. Hold the punch at a 45° angle, and drive it into the throttle body until the casting breaks away, exposing the steel plug.
  - d. Hold center punch in vertical position, and drive it into the plug. Now hold punch at a 45° angle, and drive plug out of the casting.

**NOTICE:** Hardened plug will break, rather than remaining intact. It is not necessary to remove the plug completely, but remove loose pieces to allow use

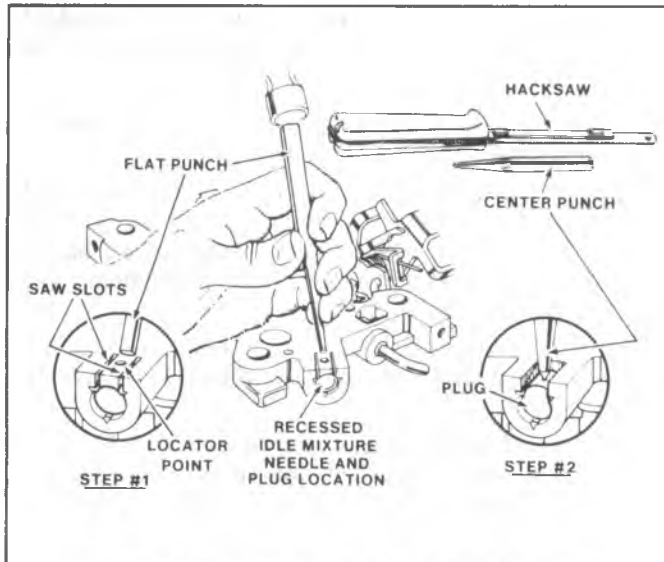

Fig. 6C9-20--Idle Mixture Needle Plug Removal

of idle mixture adjusting tool (J-29030, BT-7610B or equivalent).

e. Use idle mixture adjusting tool to remove idle mixture needle and spring from the throttle body.

### CLEANING AND INSPECTION

Metal carburetor parts should be cleaned in a cold immersion-type cleaner such as Carbon X (X-55) or equivalent.

**NOTICE:** Idle speed solenoid, electric choke, rubber and plastic parts, diaphragms, pump plunger and plastic filler block **SHOULD NOT BE IMMERSSED** in carburetor cleaner as they will harden, swell or distort.

The plastic bushing in the throttle lever will withstand normal cleaning in carburetor cleaner.

1. Thoroughly clean all metal parts and blow dry with shop air. Make sure that all fuel passages and metering parts are free of burrs and dirt. Do not pass drills or wires through jets and passages.
2. Inspect upper and lower surfaces of carburetor castings for damage.
3. Inspect holes in levers for excessive wear or out-of-round conditions. If worn, levers should be replaced. Inspect plastic bushings in levers for damage and excessive wear. Replace as required.
4. Check, repair, or replace parts if the following problems are encountered and when the carburetor is believed to be the only cause:

#### ● FLOODING

1. Inspect float valve seat for dirt, deeply worn grooves, scoring and improper sealing.
2. Inspect float valve pull clip and, if used, the float stabilizing spring, for improper installation. Be careful not to bend pull clip or spring.
3. Inspect float, float arms and hinge pin for distortion, binds, and burrs. Check density of material in the float, and if heavier than normal, replace the float.
4. Replace fuel inlet filter.

#### ● HESITATION

1. Inspect pump plunger for cracks, scores and excessive cup wear. A used pump cup will shrink when dry. If dried out, soak in fuel for 8 hours before testing.
2. Inspect pump duration spring and return spring for weakness and distortion.
3. Check pump passages and jet for dirt, improper seating of discharge check ball or thermostatically controlled bypass valve, and sorting in the pump well. Check condition of pump discharge check ball spring, and replace if necessary.
4. Check pump linkage for excessive wear, and repair or replace if necessary.

#### ● HARD STARTING - POOR COLD OPERATION

1. Check choke valve and linkage for excessive wear, binds or distortion.
2. Test vacuum break diaphragm(s) for leaks.
3. Replace fuel filter.
4. Inspect float valve for sticking, dirt, etc.
5. Also check items under "Flooding".

#### ● POOR PERFORMANCE - POOR GAS MILEAGE

1. Clean all fuel and vacuum passages in castings.
2. Check choke valve for restriction of movement.
3. Inspect power piston, metering rod, and jet for dirt, sticking, binding, damaged parts and excessive wear.
4. Check air valve and secondary metering rod for binding conditions. If air valve or metering rod is damaged, or if metering rod adjustment is changed from the factory setting, the air horn assembly must be replaced. Also check air valve lever spring for improper installation, (tension against air valve shaft pin).

#### ● ROUGH IDLE

1. Inspect gasket and gasket mating surfaces on castings for nicks, burrs and damage to sealing beads.
2. Clean all idle fuel passages.
3. If removed, inspect idle mixture needle for ridges, burrs, and bends.
4. Check throttle lever and valves for binds, nicks and other damage.
5. Check all diaphragms for ruptures and leaks.

## ASSEMBLY

### THROTTLE BODY

#### Assembly

1. Hold primary throttle lever wide open. Install lower end of pump rod in throttle lever, after aligning "squirt" on rod with slot in lever. End of rod should point outward toward the throttle lever.
2. If removed, install idle mixture needle and spring, using tool J-29030, BT-7610B or equivalent. Lightly bottom needle, then back it out four (4) turns as a preliminary idle mixture adjustment. Final idle mixture adjustment must be made on vehicle. Refer to "On Vehicle Service" Section for this procedure.

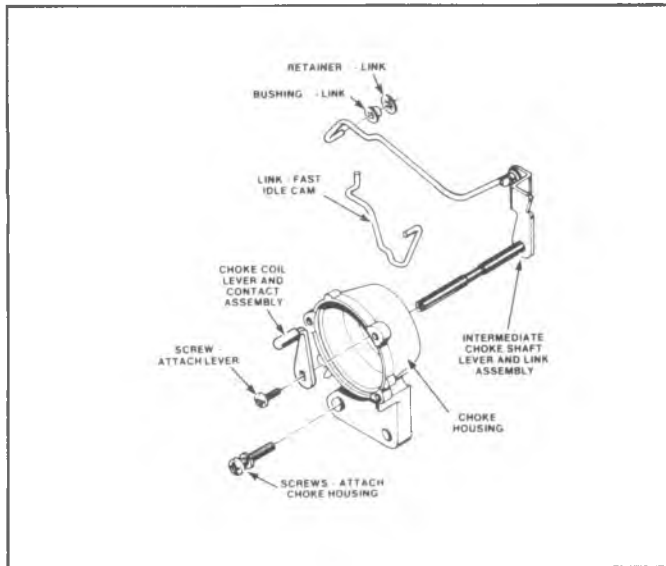

Fig. 6C9-21--Choke Assembly

## FLOAT BOWL

### Assembly

If a new float bowl assembly is used, stamp or engrave the model number on the new float bowl at location indicated in Figure 6C9-7.

1. Install new throttle body-to-bowl gasket over two locating dowels on bowl.
2. Rotate fast idle cam so that steps face fast idle screw on throttle lever when properly installed. Install throttle body, making sure the throttle body is located properly over the dowels on the float bowl. Install four throttle body-to-bowl screws and lockwashers, tighten evenly and securely. Inspect linkage to insure the lockout tang is located properly to engage slot in the secondary lever, and that the linkage moves freely and does not bind.
3. Place carburetor on suitable holding fixture.
4. Install fuel inlet filter spring, new filter assembly, new gasket and inlet nut. Torque nut to 24

N·m (18 ft. lbs.). Be sure filter is the type that includes a check valve, to meet motor vehicle safety standards. When properly installed, hole in filter (check valve end) faces the inlet nut.

**NOTICE:** Tightening beyond specified torque can damage nylon gasket, causing a fuel leak.

5. Install choke housing on throttle body, making sure the raised boss and locating lug at rear of housing fit into recesses in float bowl casting. Install choke housing attaching screws and lockwashers, and tighten screws evenly and securely.
6. Install intermediate choke shaft assembly in float bowl by pushing shaft through from the throttle lever side (Fig. 6C9-21).
7. With intermediate choke lever in the UP or 12 o'clock position, install choke coil lever (inside choke housing) on flat surface of intermediate choke shaft. Choke coil lever is properly aligned when the coil pick-up tang is in the UP position. Install choke coil lever retaining screw into end of intermediate choke shaft and tighten securely.
8. Install pump discharge check ball, spring and new plastic retainer in float bowl. Tap lightly in place until top of retainer is flush with bowl casting surface.
9. Use a wide-blade screwdriver to install float valve seat (with gasket) and the metering jet. Tighten securely. If used, insert lower plastic filler block.
10. To make adjustment easier, carefully bend float arm upward at notch in float arm before assembly.
11. Install float valve onto float arm by sliding float lever under pull clip. Correctly install pull clip by hooking the clip over the edge of the float, on the float arm facing the float pontoon, (Fig. 6C9-22). If used, the float stabilizing spring should be assembled as shown in Figure 6C9-23.
12. Install float hinge pin into float arm, with end of loop of pin facing the pump well. Install float assembly by aligning valve in the seat and float hinge pin into locating channels in the float bowl.

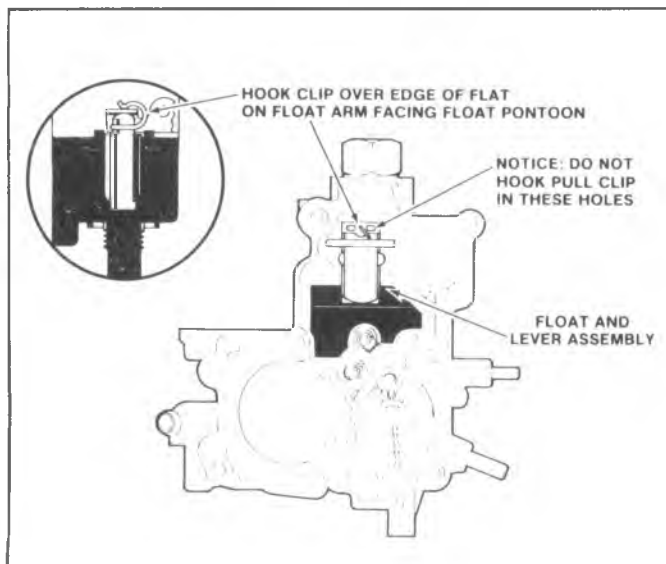

Fig. 6C9-22--Float Needle Pull Clip Location

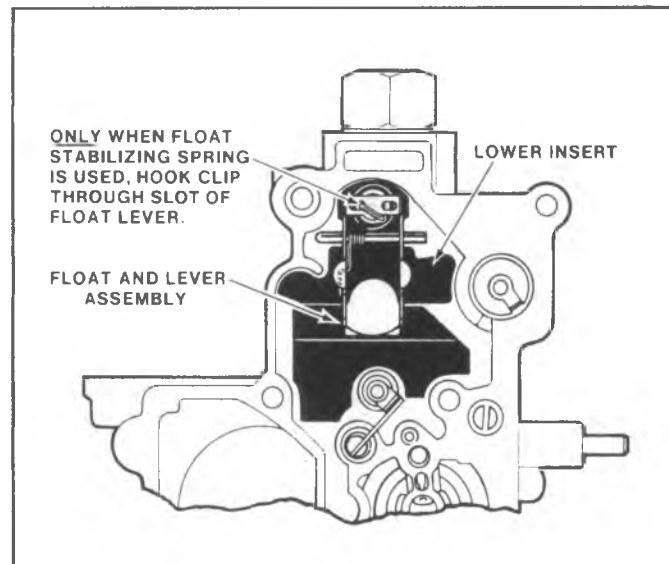

Fig. 6C9-23--Float Stabilizing Spring

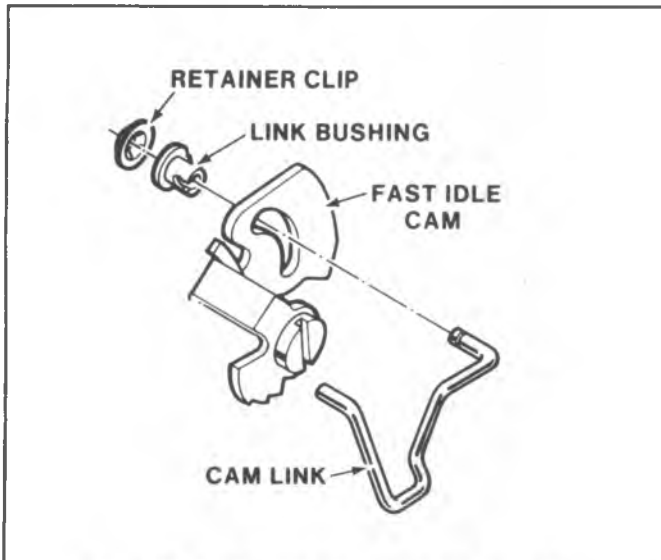

Fig. 6C9-24--Fast Idle Cam and Rod Assembly

13. Adjust float level following adjustment procedure in Figure 6C9-27. See Adjustment chart for specification at end of this section.
14. Install power piston spring into the piston bore.
15. If removed, reassemble the metering rod to the holder on the power piston. The spring must be on top of the arm when correctly assembled.
16. Install power piston into the float bowl, with the metering rod assembly into the main metering jet. Use care when installing the metering rod into the jet, to prevent damaging the metering rod tip. Firmly press down on the plastic power piston retainer to make sure the retainer is seated in the recess in the bowl, and that the top is flush with the top of the bowl casting. If necessary, use a small hammer and a drift to lightly tap the retainer into place.
17. Install plastic filler block over the float valve, pressing downward until it is properly seated, flush with the bowl casting surface.
18. Install air horn gasket on float bowl, locating gasket over two dowel locating pins on bowl.
19. Install pump return spring in pump well. Install pump plunger assembly in pump well.

## AIR HORN

### Assembly

1. Install new pump plunger steam seal and retainer in air horn casting. Stake seal retainer lightly in three places, choosing different locations than the original stakings.
2. Install vent screen assembly by installing two small attaching screws. Tighten securely.
3. Inspect the air valve shaft pin for lubrication, apply a liberal quantity of lithium base grease to the air valve shaft pin, especially at the area contacted by the windup spring.
4. Install fast idle cam rod in lower hole of choke lever, aligning "squirt" on rod with small slot in lever.

## AIR HORN TO FLOAT BOWL

### Installation

1. Rotate fast idle cam to its highest position. Tilt the air horn assembly to engage lower end of fast idle cam rod in slot of fast idle cam, and install pump rod end into hole in pump lever. Check intermediate choke rod for position and while holding down on the pump plunger assembly, carefully lower air horn assembly onto float bowl, guiding plunger stem through the seal in the air horn casting.

On some models, the fast idle cam rod is assembled to the fast idle cam with a plastic bushing and retainer. This allows the air horn to be assembled to the float bowl before installing the rod to the cam. Where used, assemble the fast idle cam rod in the slot of the fast idle cam. Install new plastic bushing and retaining clip to the rod, making sure that the large end of the bushing faces the retaining clip when installed, (fig. 6C9-24).

**NOTICE:** Do not force air horn assembly onto bowl, but lower it into place gently.

2. Install air horn-to-bowl attaching screws and lockwashers, and tighten evenly and securely, (Fig. 6C9-25).
3. Install new retainer clip through hole in end of pump rod, extending through the pump lever, making sure clip is securely locked in place.
4. Install new seal in the recess of the air horn. Install hot idle compensator valve (if used) and retain with two small attaching screws. Tighten screws securely.
5. Install plastic bushing in the hole in the choke lever, making sure small end of the bushing faces the retaining clip when installed, (Fig. 6C9-15). With choke coil lever and intermediate choke lever at the 12 o'clock position, install intermediate choke rod in the bushing. Retain rod with new clip, pressing clip securely in place with needle nose pliers. Be sure clip has full contact with rod, but that it is not seated tightly against bushing. Clearance between rod and bushing should be 0.8 mm (.030").

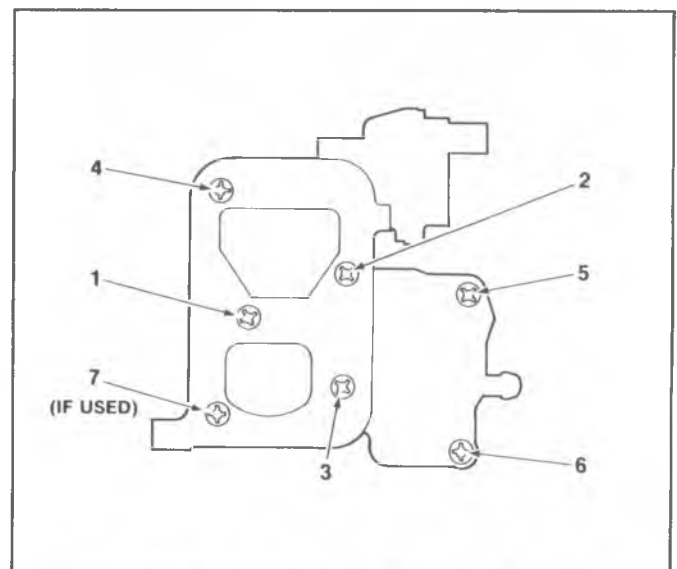

Fig. 6C9-25--Air Horn Screw Tightening Sequence

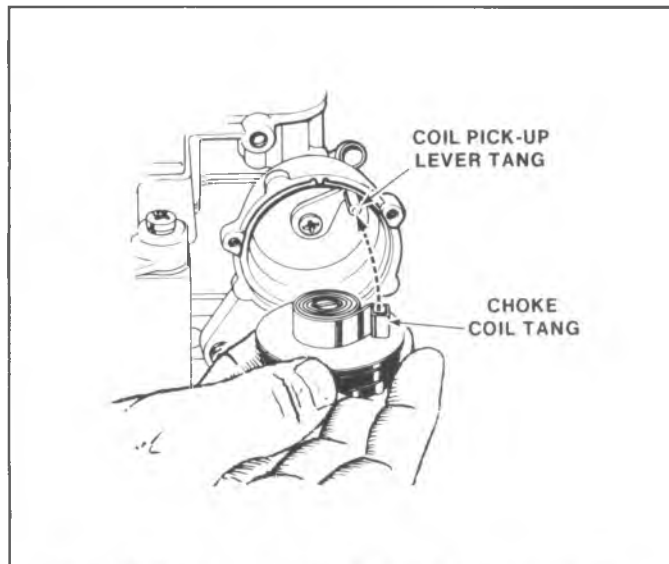

Fig. 6C9-26--"Trapped Stat" Choke Cover Installation

6. Install secondary vacuum break assembly. Rotate assembly, and start end ("T" pin) of vacuum break link into the upper slot of the choke lever. Attach bracket to throttle body with countersunk screws. Tighten screws securely.
7. If air valve rod was removed from the primary side vacuum break plunger, install plastic bushing in hole of primary side vacuum break plunger, being sure that the small end of the bushing faces the retaining clip when installed. Insert end of air valve rod through bushing. Retain with new clip, pressing clip into place using needle nose pliers. Make sure clip has full contact with rod, but that it is not seated tightly against the bushing. Clearance between the rod and the bushing should be 0.8mm (.030").
8. Rotate primary side vacuum break assembly and insert end of air valve rod into the slot of air valve lever and end ("T" pin) of vacuum break link into the lower slot of the choke lever. Connect primary vacuum break hose to the tube on the throttle body and the tube on the vacuum break unit. Position bracket over the locating

lug on the air horn and install with two countersunk screws in air horn and one screw, with lock washer, in the throttle body. Tighten screws securely.

9. Perform the two adjustments indicated below, which will be found in the carburetor adjustment section:

**Air Valve Spring Adjustment**, Figure 6C9-28

**Choke Coil Lever Adjustment**, Figure 6C9-29

10. Use a choke cover retainer kit for installing the choke cover and coil assembly in the choke housing, aligning the notch in the cover with the casting projection on the housing cover flange. Where a thermostatic coil with a "trapped" (box-shaped) pick-up tang is used, be sure that the "trap" (box) surrounds the choke coil lever inside the choke housing, (Fig. 6C9-26).

Install proper retainers and rivets contained in the kit, using a suitable riveting tool.

**NOTICE:** DO NOT install a Choke Cover Gasket in the choke housing, as such installation would prevent grounding of the electrically heated choke element.

## ADJUSTMENTS

The carburetor adjustments that are part of Unit Repair, in most cases, may be performed on the vehicle.

The following adjustment procedures are arranged in a logical sequence for obtaining good results.

- Float Adjustment (Fig. 6C9-27)
- Air Valve Spring Adjustment (Fig. 6C9-28)
- Choke Coil Lever Adjustment (Fig. 6C9-29)
- Choke Angle Gage (Fig. 6C9-30)
- Vacuum Break Adjustment Information (Fig. 6C9-31)
- Choke Rod Fast Idle Cam Adjustment (Fig. 6C9-32)
- Primary Vacuum Break Adjustment (Fig. 6C9-33)
- Air Valve Rod Adjustment (Fig. 6C9-34)
- Secondary Vacuum Break Adjustment (Fig. 6C9-35)
- Unloader Adjustment (Fig. 6C9-36)
- Secondary Lockout Adjustment (Fig. 6C9-37)

Refer to ON-VEHICLE SERVICE for additional carburetor adjustments performed on the vehicle.

Refer to the end of this section for special tools.

Refer to the end of this section for carburetor specifications.

- ① HOLD RETAINER IN PLACE.
- ② PUSH FLOAT DOWN LIGHTLY AGAINST NEEDLE.
- ③ GAGE AT LARGE TOE OF FLOAT, AT POINT FARTHEST FROM FLOAT HINGE.
- ④ REMOVE FLOAT AND BEND FLOAT ARM UP OR DOWN TO ADJUST. (SOME MODELS HAVE FLOAT STABILIZER SPRING. USE CARE IN REMOVING.)
- ⑤ VISUALLY CHECK FLOAT ALIGNMENT.

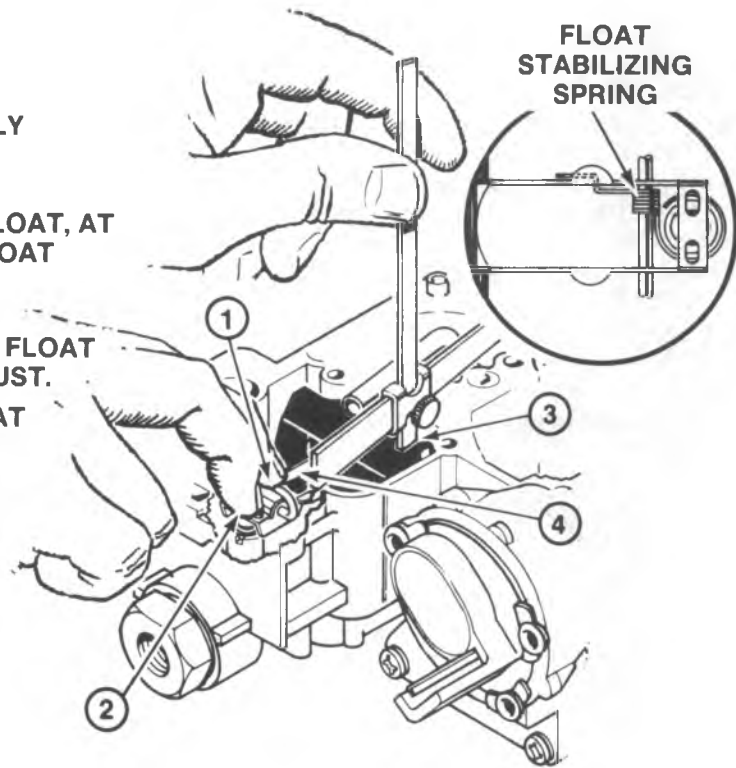

Fig. 6C9-27--Float Adjustment

- ① IF NECESSARY, REMOVE INTERMEDIATE CHOKE ROD, TO GAIN ACCESS TO LOCK SCREW.
- ② LOOSEN LOCK SCREW USING 3/32" (2.381mm) HEX WRENCH.
- ③ TURN TENSION-ADJUSTING SCREW CLOCKWISE UNTIL AIR VALVE OPENS SLIGHTLY. TURN ADJUSTING SCREW COUNTER-CLOCKWISE UNTIL AIR VALVE JUST CLOSURES. CONTINUE COUNTER-CLOCKWISE SPECIFIED NUMBER OF TURNS.
- ④ TIGHTEN LOCK SCREW.
- ⑤ APPLY LITHIUM BASE GREASE TO LUBRICATE PIN AND SPRING CONTACT AREA.

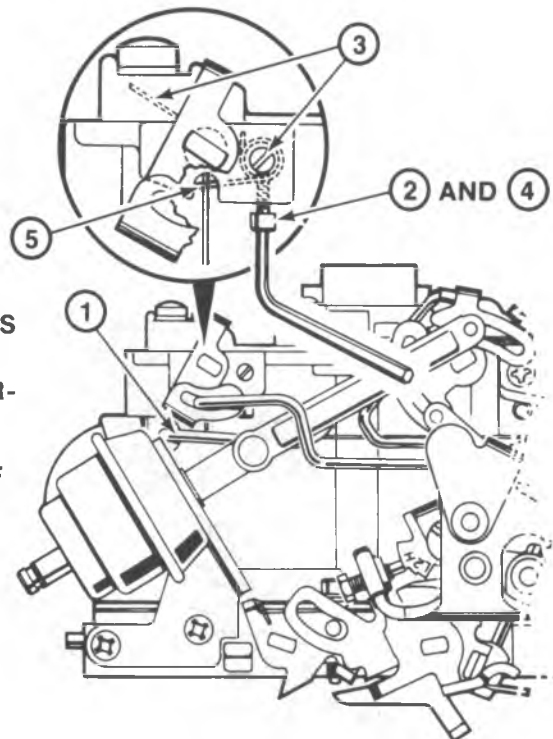

Fig. 6C9-28--Air Valve Spring Adjustment



- ① IF RIVETED, DRILL OUT AND REMOVE RIVETS. REMOVE CHOKE COVER AND COIL ASSEMBLY.
- ② PLACE FAST IDLE SCREW ON HIGH STEP OF FAST IDLE CAM.
- ③ PUSH ON INTERMEDIATE CHOKE LEVER UNTIL CHOKE VALVE IS CLOSED.
- ④ INSERT .085" (2.18mm) PLUG GAGE IN HOLE.
- ⑤ EDGE OF LEVER SHOULD JUST CONTACT SIDE OF GAGE.
- ⑥ SUPPORT AT "S" AND BEND INTERMEDIATE CHOKE ROD TO ADJUST.

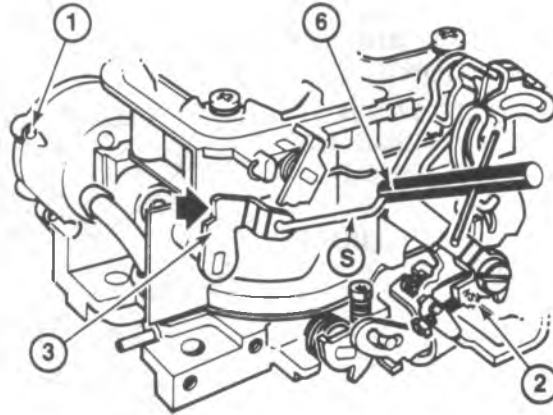
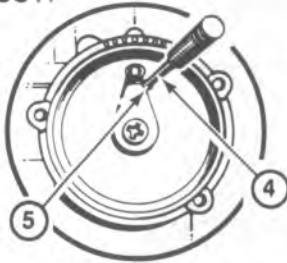

Fig. 6C9-29--Choke Coil Lever Adjustment

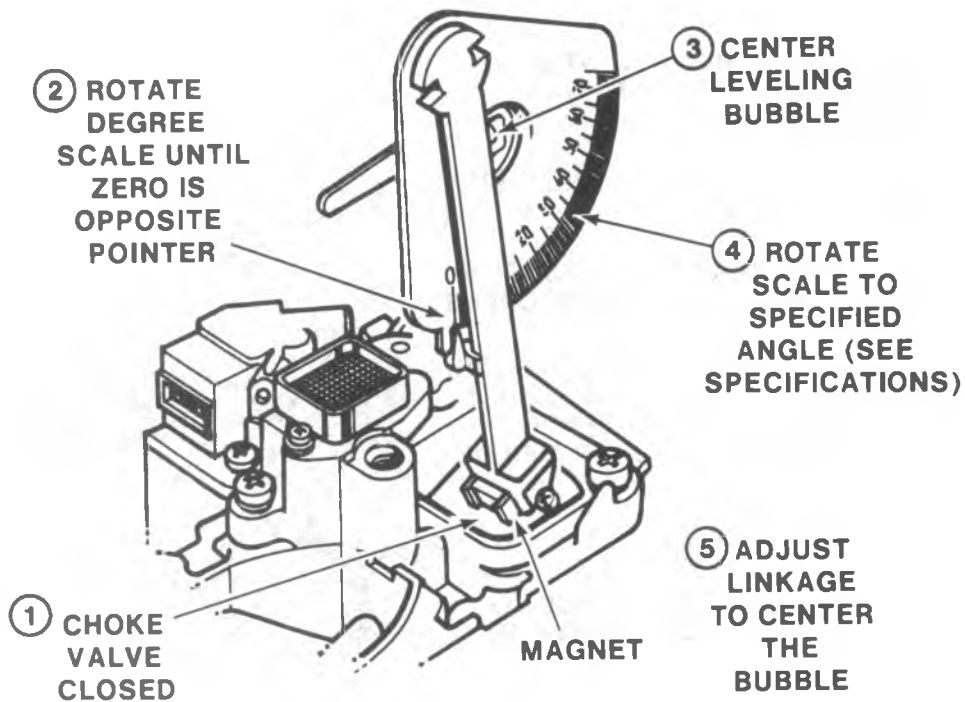
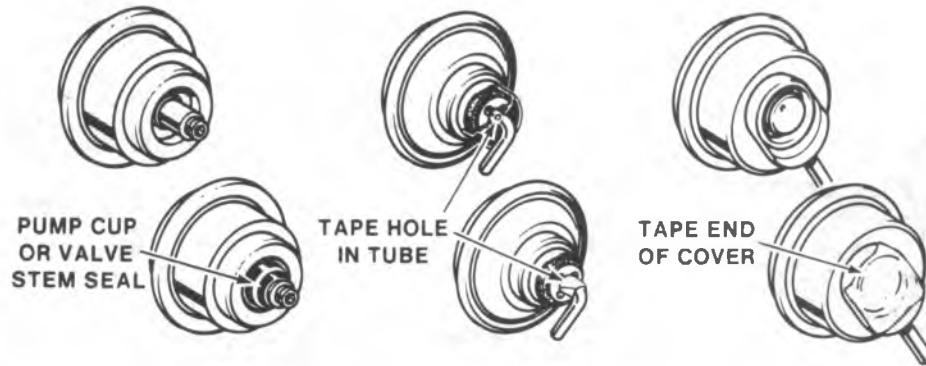

Fig. 6C9-30--Choke Angle Gage

**PLUGGING AIR BLEED HOLES**



**BUCKING SPRINGS**

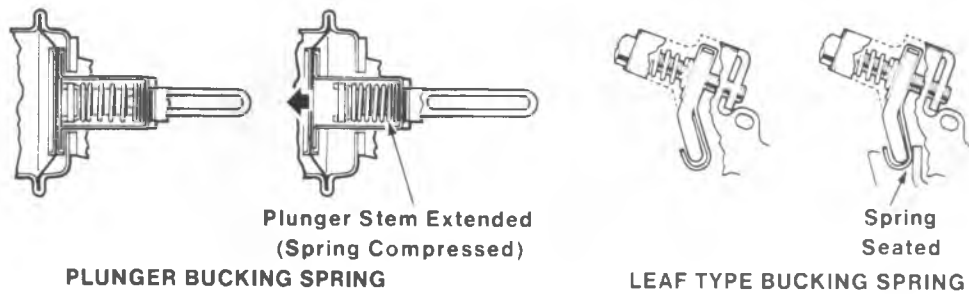

Fig. 6C9-31--Vacuum Break Adjustment Information

- ① ATTACH RUBBER BAND TO INTERMEDIATE CHOKE LEVER.
- ② OPEN THROTTLE TO ALLOW CHOKE VALVE TO CLOSE.
- ③ SET UP ANGLE GAGE AND SET ANGLE TO SPECIFICATIONS.
- ④ PLACE FAST IDLE SCREW ON SECOND STEP OF CAM AGAINST RISE OF HIGH STEP.
- ⑤ PUSH ON CHOKE SHAFT LEVER TO OPEN CHOKE VALVE AND TO MAKE CONTACT WITH BLACK CLOSING TANG.
- ⑥ SUPPORT AT "S" AND ADJUST BY BENDING FAST IDLE CAM ROD UNTIL BUBBLE IS CENTERED.

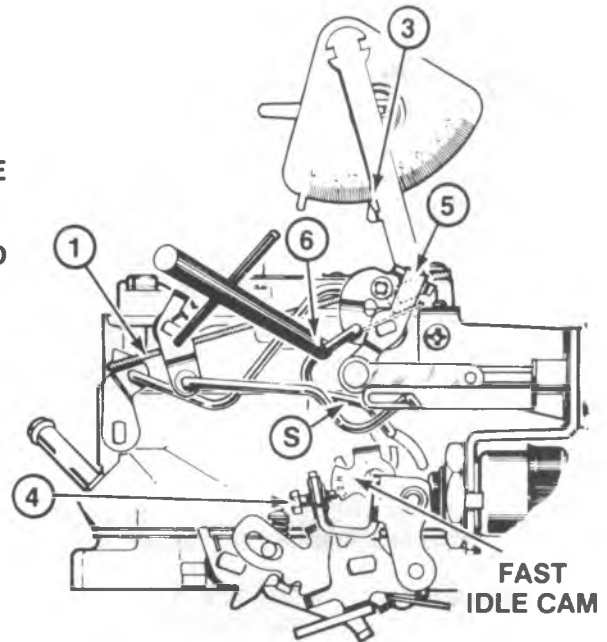

Fig. 6C9-32--Choke Rod-Fast Idle Cam Adjustment

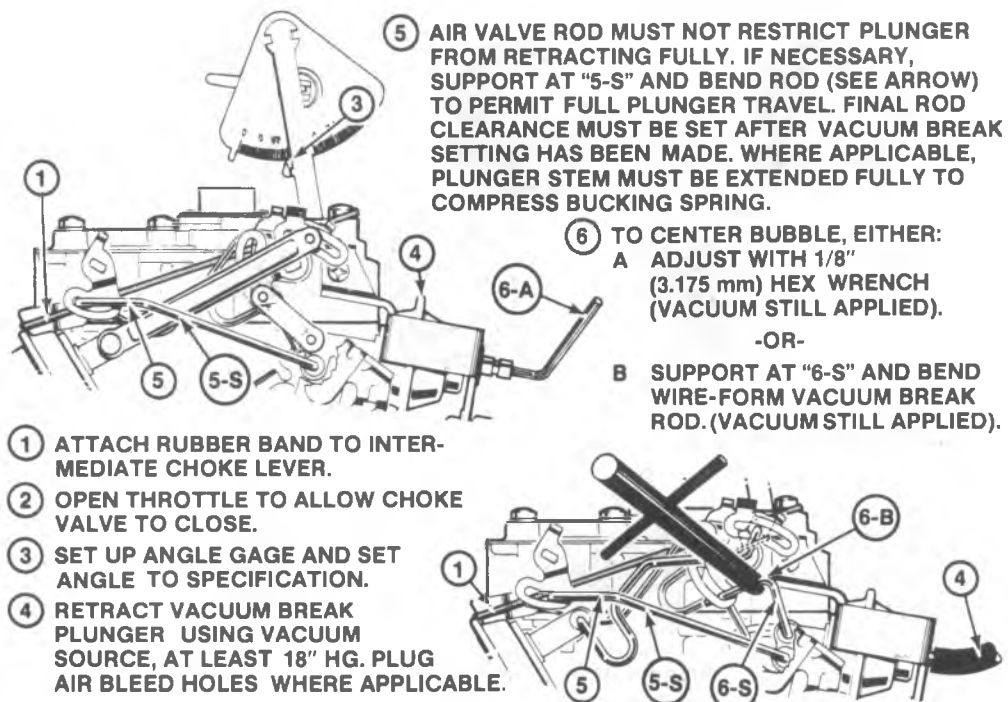

Fig. 6C9-33--Primary Vacuum Break Adjustment

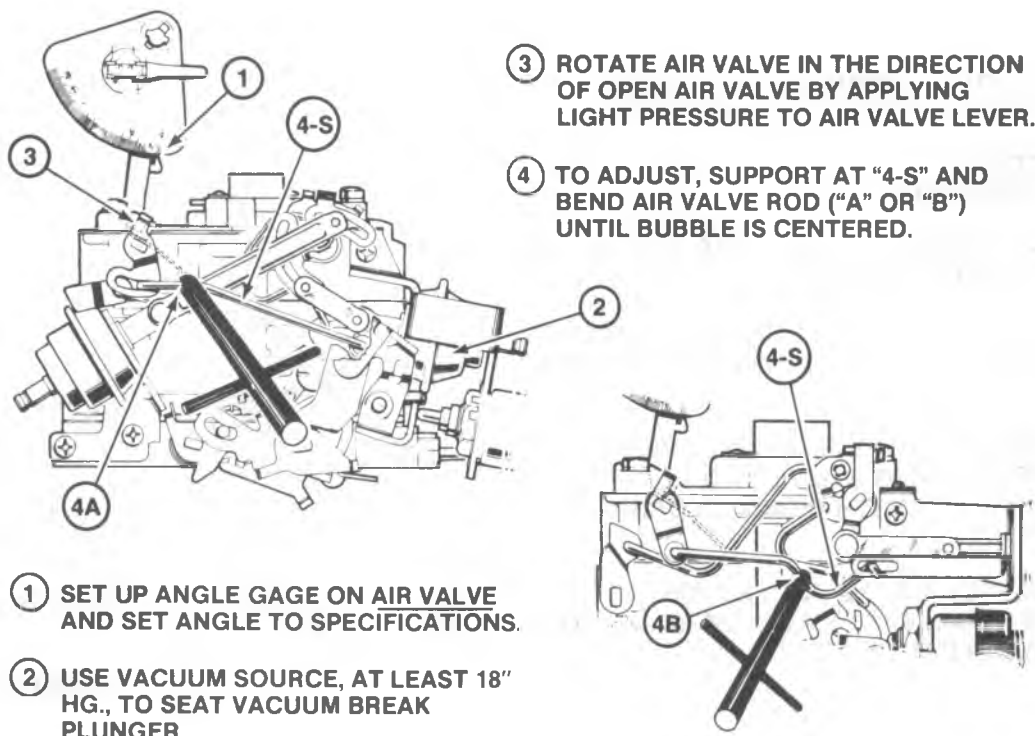

Fig. 6C9-34--Air Valve Rod Adjustment

- ① ATTACH RUBBER BAND TO INTER-MEDIATE CHOKE LEVER.
- ② OPEN THROTTLE TO ALLOW CHOKE VALVE TO CLOSE.
- ③ SET UP ANGLE GAGE AND SET ANGLE TO SPECIFICATION.
- ④ RETRACT VACUUM BREAK PLUNGER USING VACUUM SOURCE, AT LEAST 18" HG. PLUG AIR BLEED HOLES WHERE APPLICABLE.  
WHERE APPLICABLE, PLUNGER STEM MUST BE EXTENDED FULLY TO COMPRESS PLUNGER BUCKING SPRING.
- ⑤ TO CENTER BUBBLE, EITHER:
  - A. ADJUST WITH 1/8" (3.175 mm) HEX WRENCH (VACUUM STILL APPLIED)
  - OR
  - B. SUPPORT AT "5-S", BEND WIRE-FORM VACUUM BREAK ROD (VACUUM STILL APPLIED)

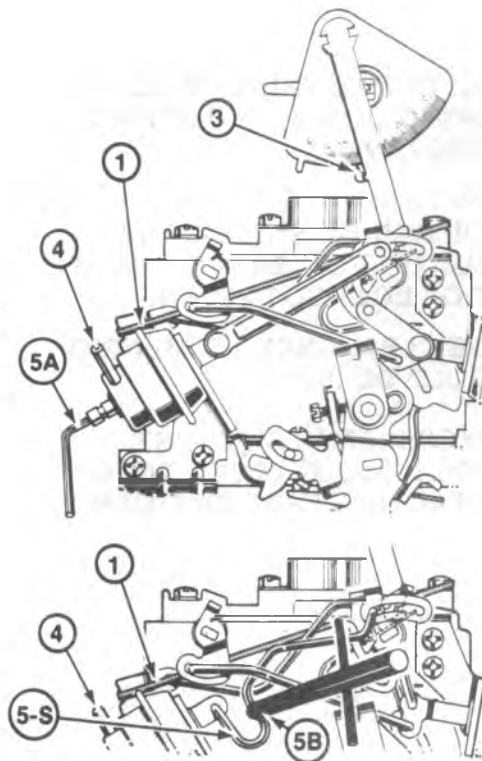

Fig. 6C9-35--Secondary Vacuum Break

- ① ATTACH RUBBER BAND TO INTER-MEDIATE CHOKE LEVER.
- ② OPEN THROTTLE TO ALLOW CHOKE VALVE TO CLOSE.
- ③ SET UP ANGLE GAGE AND SET ANGLE TO SPECIFICATIONS.
- ④ HOLD THROTTLE LEVER IN WIDE OPEN POSITION.
- ⑤ PUSH ON CHOKE SHAFT LEVER TO OPEN CHOKE VALVE AND TO MAKE CONTACT WITH BLACK CLOSING TANG.
- ⑥ ADJUST BY BENDING TANG UNTIL BUBBLE IS CENTERED.

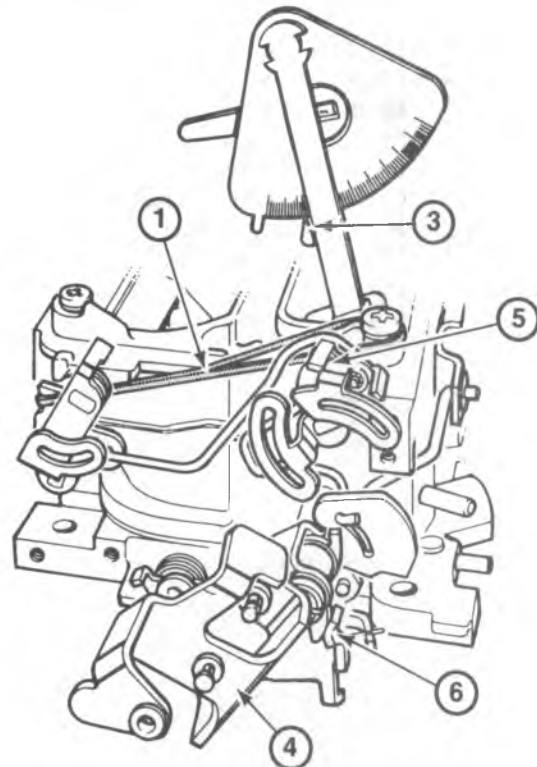

Fig. 6C9-36--Unloader Adjustment

- ① HOLD CHOKE VALVE WIDE OPEN BY PUSHING DOWN ON INTERMEDIATE CHOKE LEVER.
- ② OPEN THROTTLE LEVER UNTIL END OF SECONDARY ACTUATING LEVER IS OPPOSITE TOE OF LOCKOUT LEVER.
- ③ GAGE CLEARANCE - DIMENSION SHOULD BE .025".
- ④ IF NECESSARY TO ADJUST, BEND LOCKOUT LEVER TANG CONTACTING FAST IDLE CAM.

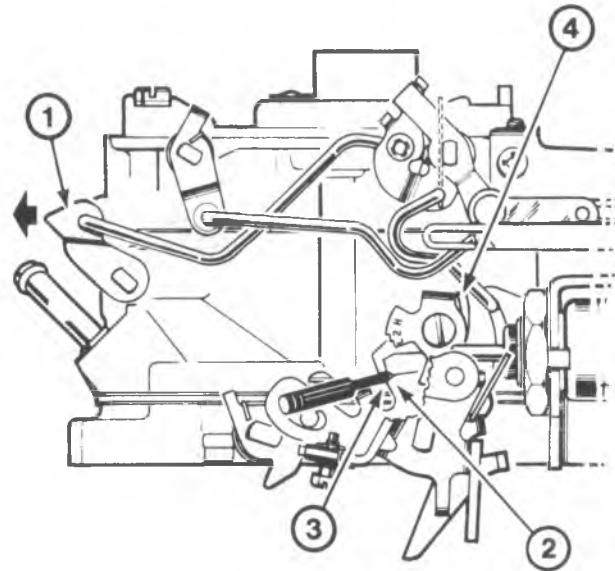

Fig. 6C9-37--Secondary Lockout Adjustment

## SPECIAL TOOLS

|                                  |                      |
|----------------------------------|----------------------|
| Idle Mixture Socket.....         | J-29030-B/BT-7610-B  |
| Float Level Scale .....          | J-9789-90/BT-8037    |
| Bending Tool .....               | J-9789-111/BT-3007   |
| Carburetor Stand.....            | J-9789-118A/BT-30-15 |
| Float Level Gage.....            | J-9789-135/BT-8104   |
| Carburetor Choke Angle Gage..... | J-26701-A/BT-7704    |
| Hand Vacuum Device .....         | J-23738/BT-7517      |
| Metering Jet Remover .....       | J-28696-B/BT-7928    |
| Carburetor Gage Set .....        | J-9789-C/BT-3005-A   |
| Digital Multimeter.....          | J-29125-A/BT-3450    |

## MODEL 2SE ADJUSTMENT CARBURETOR SPECIFICATIONS – 4.1L ENGINE

| CARBU-<br>RETOR<br>NUMBER | FLOAT<br>LEVEL |      | AIR<br>VALVE<br>SPRING<br>(TURNS) | CHOKE<br>COIL<br>LEVER | FAST<br>IDLE<br>CAM<br>(CHOKE<br>ROD) | VAC.<br>BREAK<br>PRI. | AIR<br>VALVE<br>ROD | VAC.<br>BREAK<br>SEC. | UN-<br>LOADER | PROPANE<br>ENRICH-<br>MENT<br>(RPM) |
|---------------------------|----------------|------|-----------------------------------|------------------------|---------------------------------------|-----------------------|---------------------|-----------------------|---------------|-------------------------------------|
|                           | mm             | Inch |                                   |                        |                                       |                       |                     |                       |               |                                     |
| 17083410                  | 4.5            | 3/16 | –                                 | .085                   | 15°                                   | 23°                   | 1°                  | 38°                   | 42°           |                                     |
| 17083411                  | 4.5            | 3/16 | –                                 | .085                   | 15°                                   | 26°                   | 1°                  | 38°                   | 42°           |                                     |
| 17083412                  | 4.5            | 3/16 | –                                 | .085                   | 15°                                   | 23°                   | 1°                  | 38°                   | 42°           |                                     |
| 17083413                  | 4.5            | 3/16 | –                                 | .085                   | 15°                                   | 26°                   | 1°                  | 38°                   | 42°           |                                     |
| 17083414                  | 4.5            | 3/16 | –                                 | .085                   | 15°                                   | 23°                   | 1°                  | 38°                   | 42°           |                                     |
| 17083415                  | 4.5            | 3/16 | –                                 | .085                   | 15°                                   | 26°                   | 1°                  | 38°                   | 42°           |                                     |
| 17083416                  | 4.5            | 3/16 | –                                 | .085                   | 15°                                   | 23°                   | 1°                  | 38°                   | 42°           |                                     |
| 17083417                  | 4.5            | 3/16 | –                                 | .085                   | 15°                                   | 26°                   | 1°                  | 38°                   | 42°           |                                     |
| 17083419                  | 4.5            | 3/16 | –                                 | .085                   | 15°                                   | 26°                   | 1°                  | 38°                   | 42°           |                                     |
| 17083421                  | 4.5            | 3/16 | –                                 | .085                   | 15°                                   | 26°                   | 1°                  | 38°                   | 42°           |                                     |
| 17083423                  | 4.5            | 3/16 | –                                 | .085                   | 15°                                   | 28°                   | 1°                  | 38°                   | 42°           |                                     |
| 17083425                  | 4.5            | 3/16 | –                                 | .085                   | 15°                                   | 26°                   | 1°                  | 38°                   | 42°           |                                     |
| 17083427                  | 4.5            | 3/16 | –                                 | .085                   | 15°                                   | 26°                   | 1°                  | 38°                   | 42°           |                                     |
| 17083429                  | 4.5            | 3/16 | –                                 | .085                   | 15°                                   | 28°                   | 1°                  | 38°                   | 42°           |                                     |
| 17083560                  | 4.5            | 3/16 | –                                 | .085                   | 15°                                   | 28°                   | 1°                  | 38°                   | 42°           |                                     |
| 17083562                  | 4.5            | 3/16 | –                                 | .085                   | 15°                                   | 28°                   | 1°                  | 38°                   | 42°           |                                     |
| 17083565                  | 4.5            | 3/16 | –                                 | .085                   | 15°                                   | 28°                   | 1°                  | 38°                   | 42°           |                                     |
| 17083569                  | 4.5            | 3/16 | –                                 | .085                   | 15°                                   | 28°                   | 1°                  | 38°                   | 42°           |                                     |



## SECTION 6C10

### CARBURETOR MODEL M4ME/M4MC

ALL NEW GM VEHICLES ARE CERTIFIED BY THE UNITED STATES ENVIRONMENTAL PROTECTION AGENCY AS CONFORMING TO THE REQUIREMENTS OF THE REGULATIONS FOR THE CONTROL OF AIR POLLUTION FROM NEW MOTOR VEHICLES. THIS CERTIFICATION IS CONTINGENT ON CERTAIN ADJUSTMENTS BEING SENT TO FACTORY STANDARDS. IN MOST CASES, THESE ADJUSTMENT POINTS EITHER HAVE BEEN PERMANENTLY SEALED AND/OR MADE INACCESSIBLE TO PREVENT INDISCRIMINATE OR ROUTINE ADJUSTMENT IN THE FIELD. FOR THIS REASON, THE FACTORY PROCEDURE FOR TEMPORARILY REMOVING PLUGS, CAP, ETC., FOR PURPOSES OF SERVICING THE PRODUCT, MUST BE STRICTLY FOLLOWED AND, WHEREVER PRACTICABLE, RETURNED TO THE ORIGINAL INTENT OF THE DESIGN.

### CONTENTS

|   |        |  |         |
|---|--------|--|---------|
| General Description.....                    | 6C10-1 | Idle Mixture Check and Adjustment (HD) ..... | 6C10-10 |
| Diagnosis.....                              | 6C10-6 | Fuel Filter Replacement .....                | 6C10-11 |
| On-Vehicle Service.....                     | 6C10-6 | Carburetor Mounting Torque .....             | 6C10-11 |
| General Information.....                    | 6C10-6 | Carburetor Replacement.....                  | 6C10-11 |
| Carburetor Identification .....             | 6C10-6 | Unit Repair.....                             | 6C10-12 |
| Float Mechanical Level Check .....          | 6C10-6 | Disassembly .....                            | 6C10-12 |
| Fast Idle Adjustment.....                   | 6C10-6 | Cleaning.....                                | 6C10-17 |
| Idle Speed Adjustment.....                  | 6C10-6 | Assembly.....                                | 6C10-18 |
| Choke and Hoses.....                        | 6C10-6 | Unit Repair Adjustments.....                 | 6C10-20 |
| Carburetor Choke Check .....                | 6C10-6 | Special Tools.....                           | 6C10-27 |
| Idle Speed Solenoid Check.....              | 6C10-9 | Adjustment Specifications.....               | 6C10-28 |
| Idle Mixture Check and Adjustment (LD)..... | 6C10-9 |  |         |

### GENERAL DESCRIPTION

The Models M4ME and M4MC are four barrel, two stage carburetors with proven carryover design features. The carburetor comprises three major assemblies: the air horn, the float bowl and the throttle body. It has six basic operating systems (Figures 6C10-1 through 6C10-8):

- FLOAT
- IDLE
- MAIN METERING
- POWER
- PUMP
- CHOKE

A single float chamber supplies fuel to all carburetor bores. A closed-cell rubber float, brass needle seat, and plastic tipped float valve with pull clip, are used to control fuel level in the float chamber. A vacuum-operated power piston and metering rods control the air/fuel metering in the primary bores of the carburetor. The tapered metering rods are attached to the power piston and move in fixed metering jets to provide the fuel flow for varying engine demands.

The air valves and metering rods control the air/fuel metering in the secondary bores of the carburetor. A pair of tapered metering rods are attached to a hanger, which operates by cam action resulting from the air valve angle, and provides the additional fuel flow necessary during increased engine air flow at wide open throttle. The pump system uses a pump plunger to provide extra fuel during quick throttle openings.

The Model M4ME employs an electrically heated choke coil, and Model M4MC uses a hot air heated choke coil, to provide the choke valve closing force for cold startup and for correct opening timing during warmup. Vacuum break units control initial choke valve opening at start and during warmup. An unloader tang on the throttle lever forces the choke valve open, to purge a flooded engine, when the accelerator is pressed to the floor. A fast idle cam, following choke valve movement, acts as a graduated throttle stop, to provide increased idle speed during warmup. On some models, an Idle Speed Solenoid is used to position the primary throttle valve to provide engine idle speed requirements.



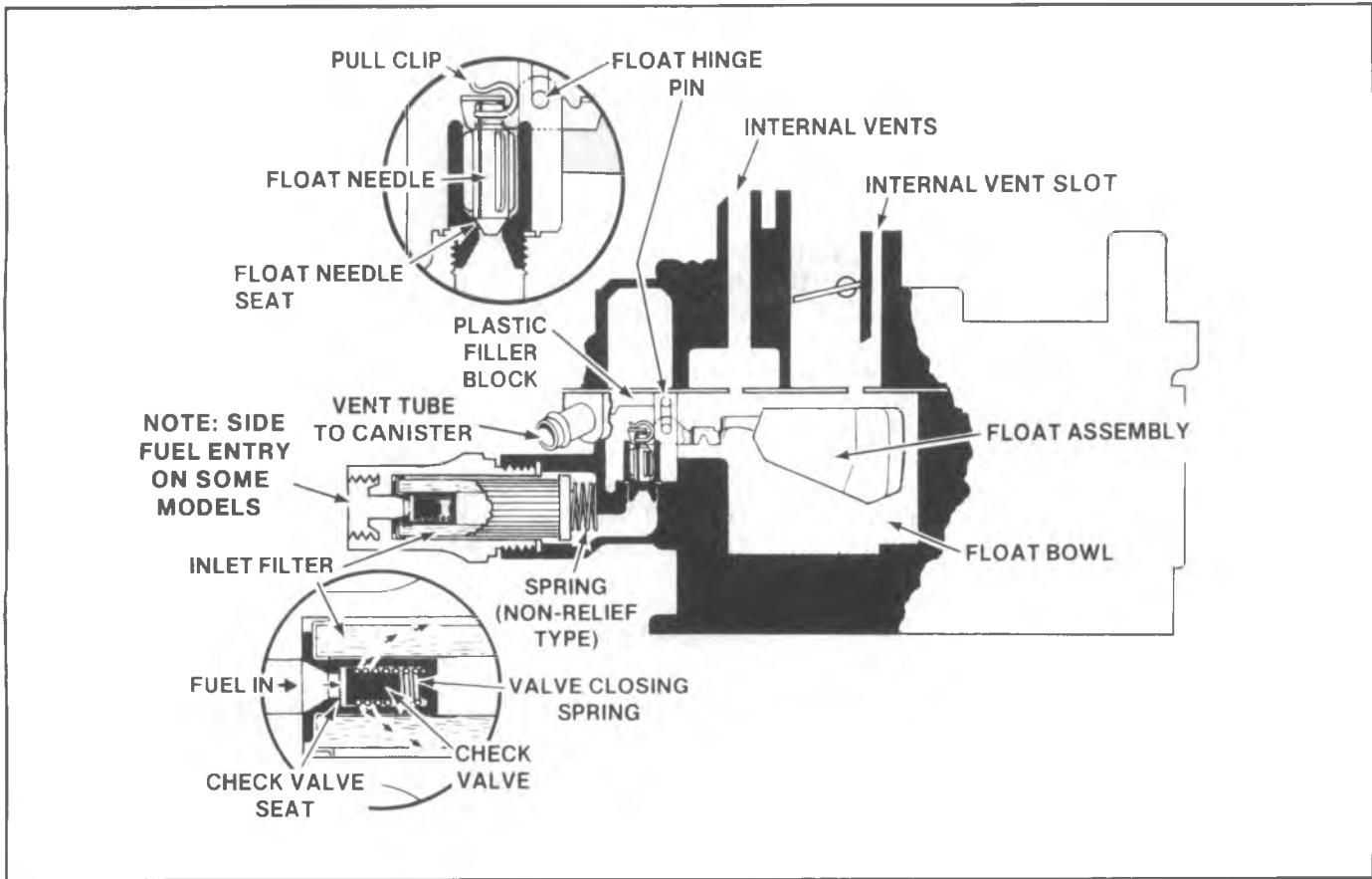

Fig. 6C10-1--Float System

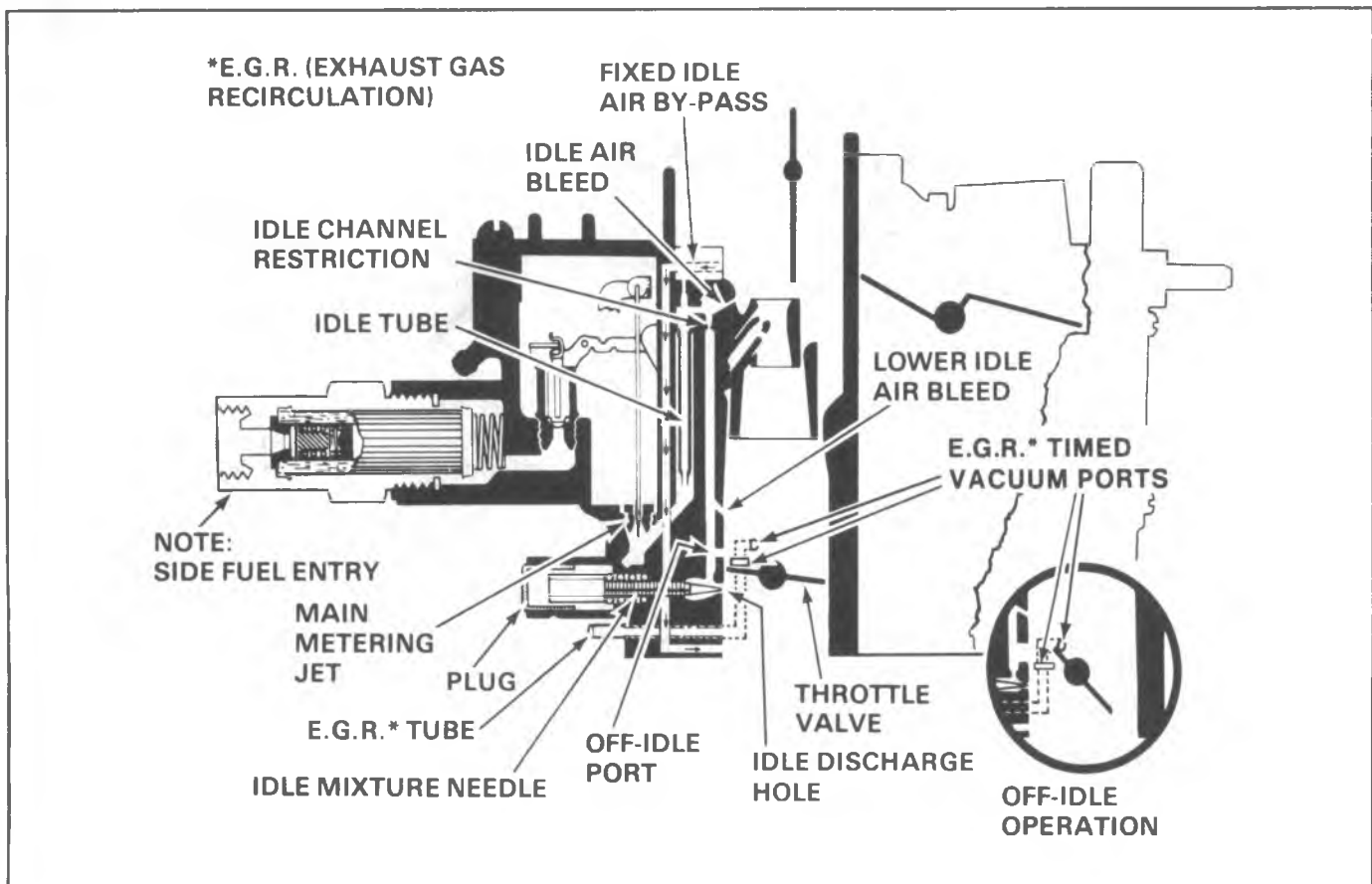

Fig. 6C10-2--Idle System

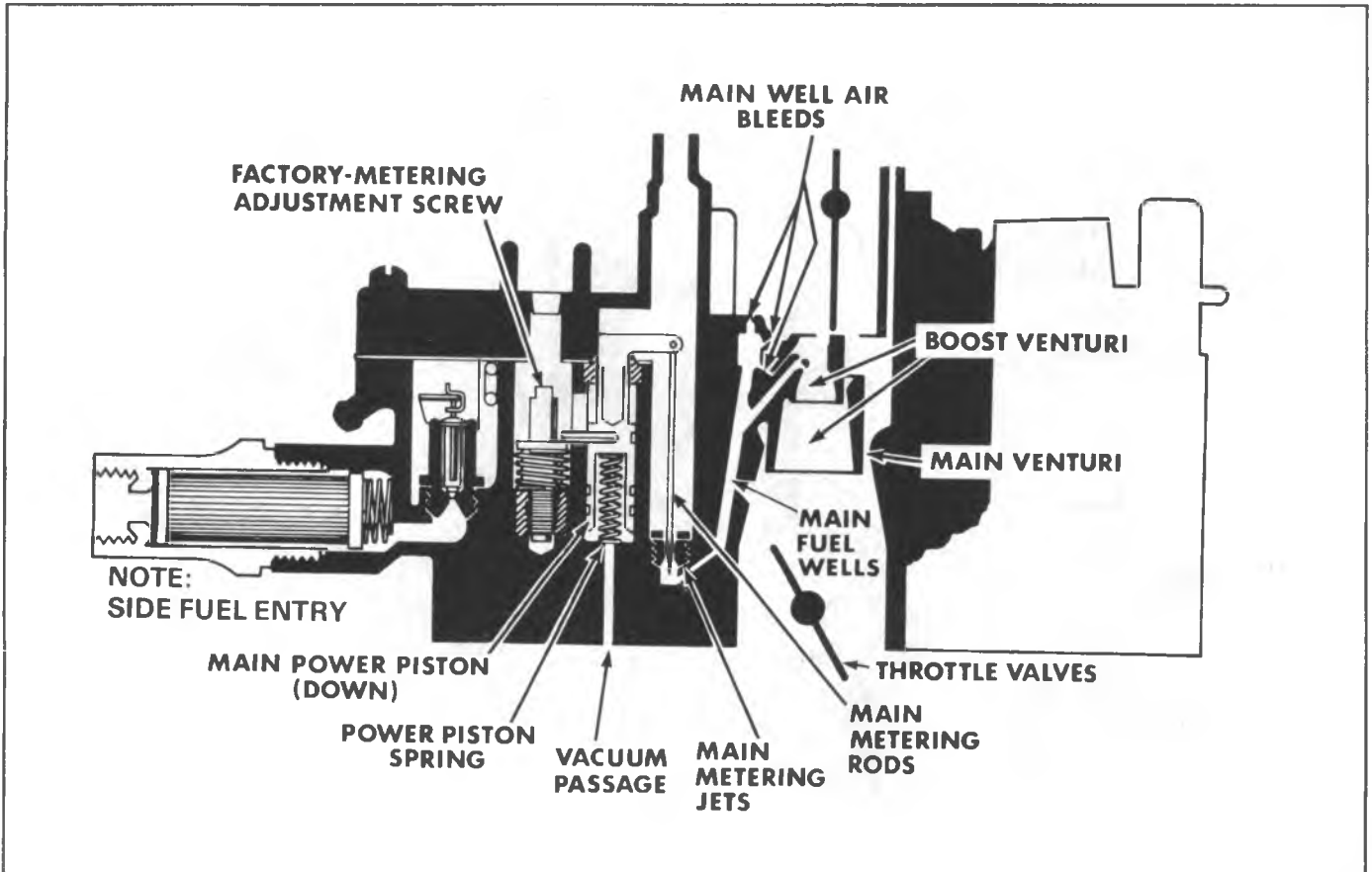

Fig. 6C10-3--Main Metering System

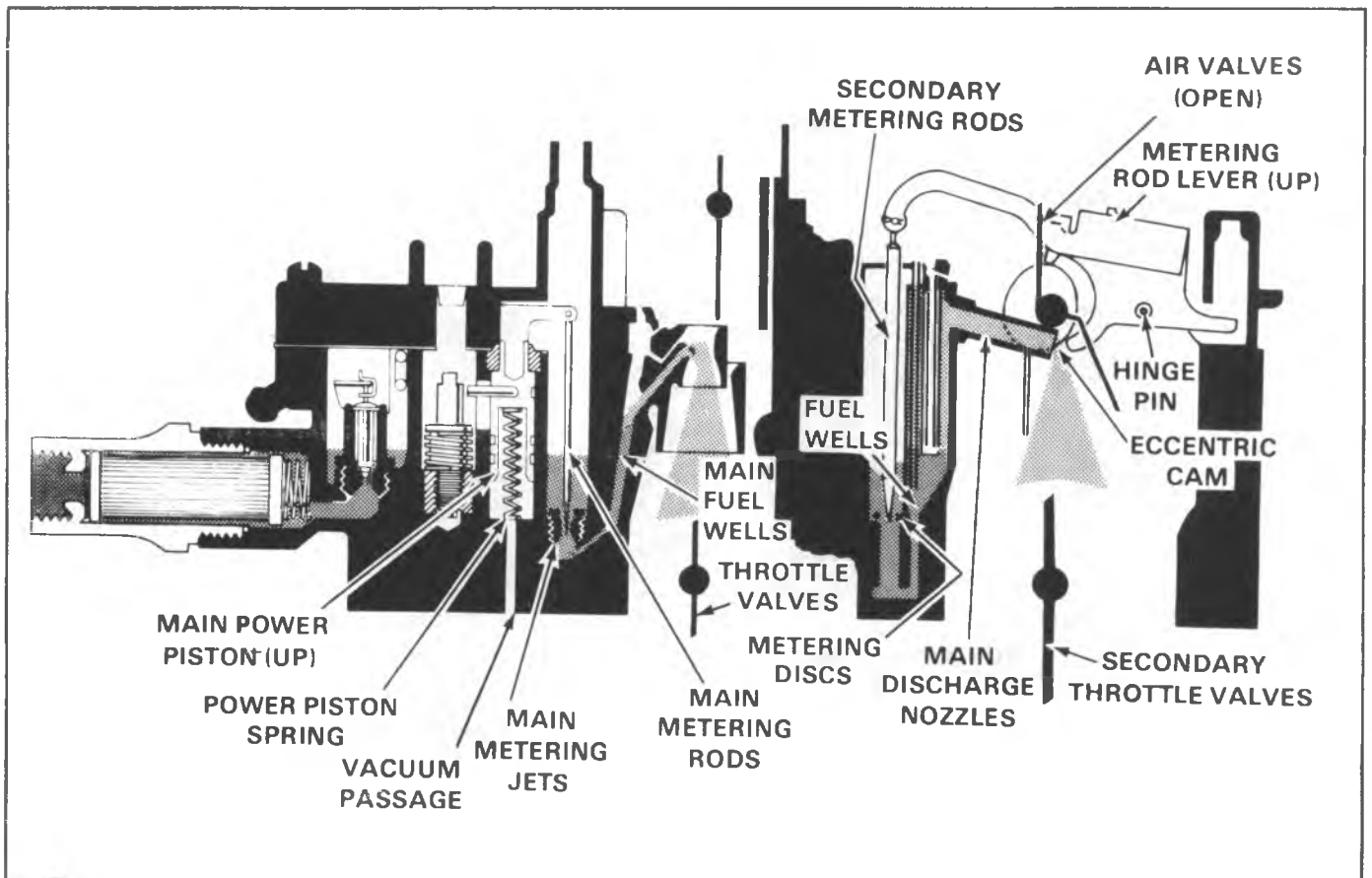

Fig. 6C10-4--Power System

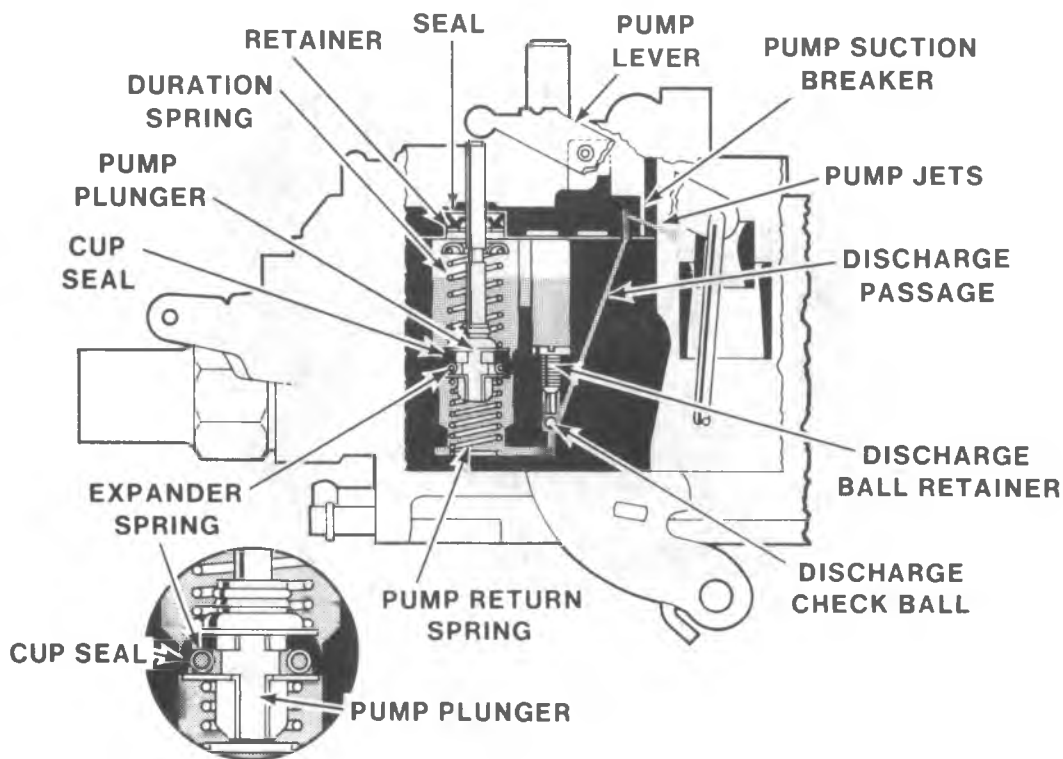

Fig. 6C10-5--Pump System

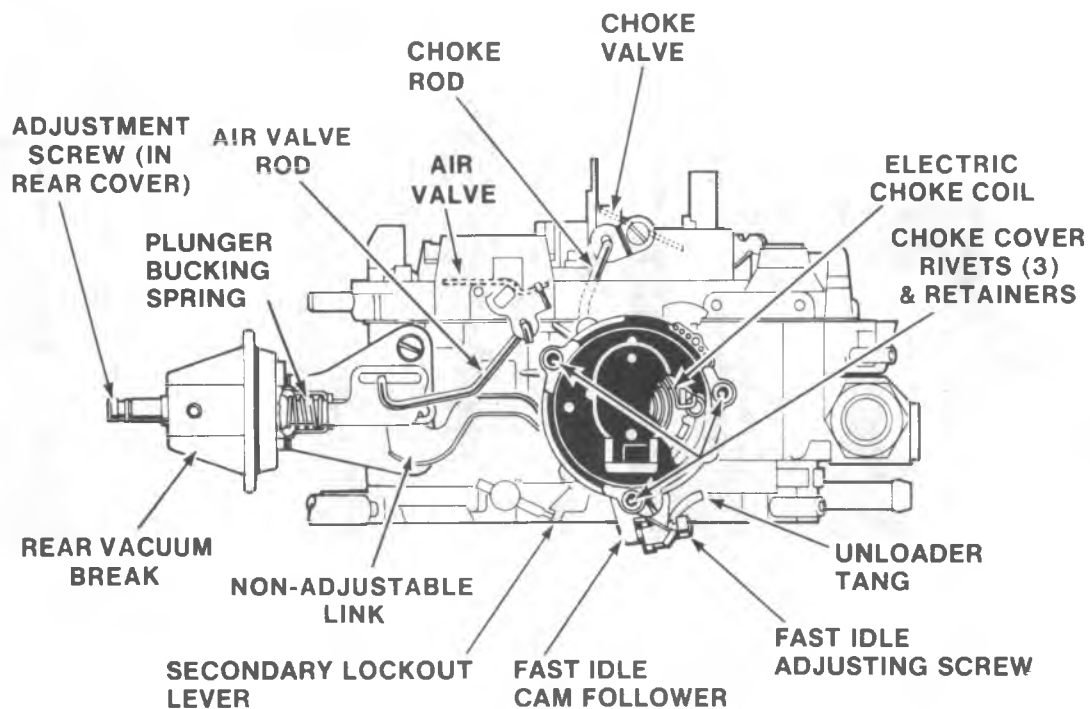

Fig. 6C10-6--Choke System - M4ME (with Rear Vacuum Break)

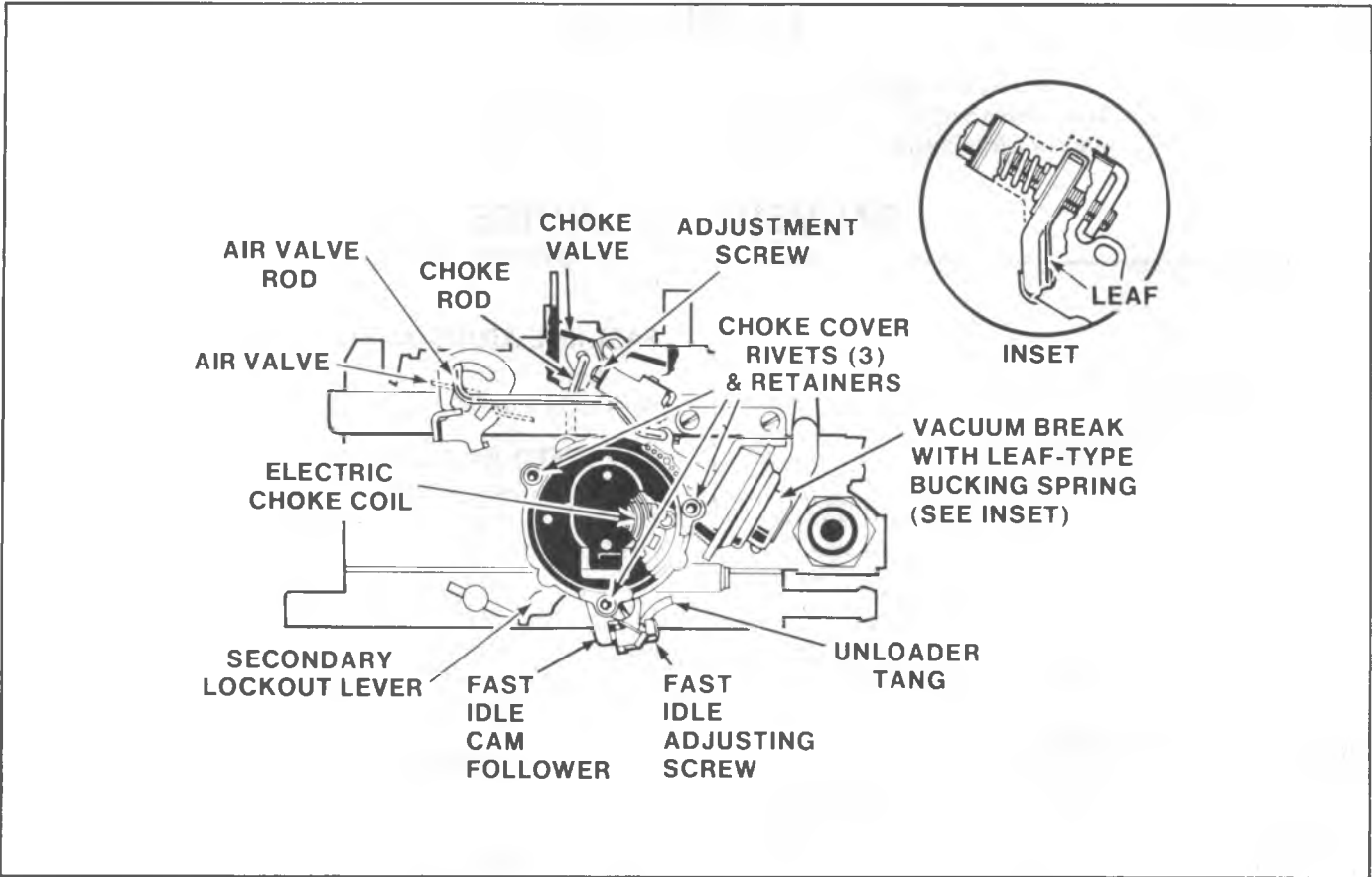

Fig. 6C10-7--Choke System - M4ME (without Rear Vacuum Break)

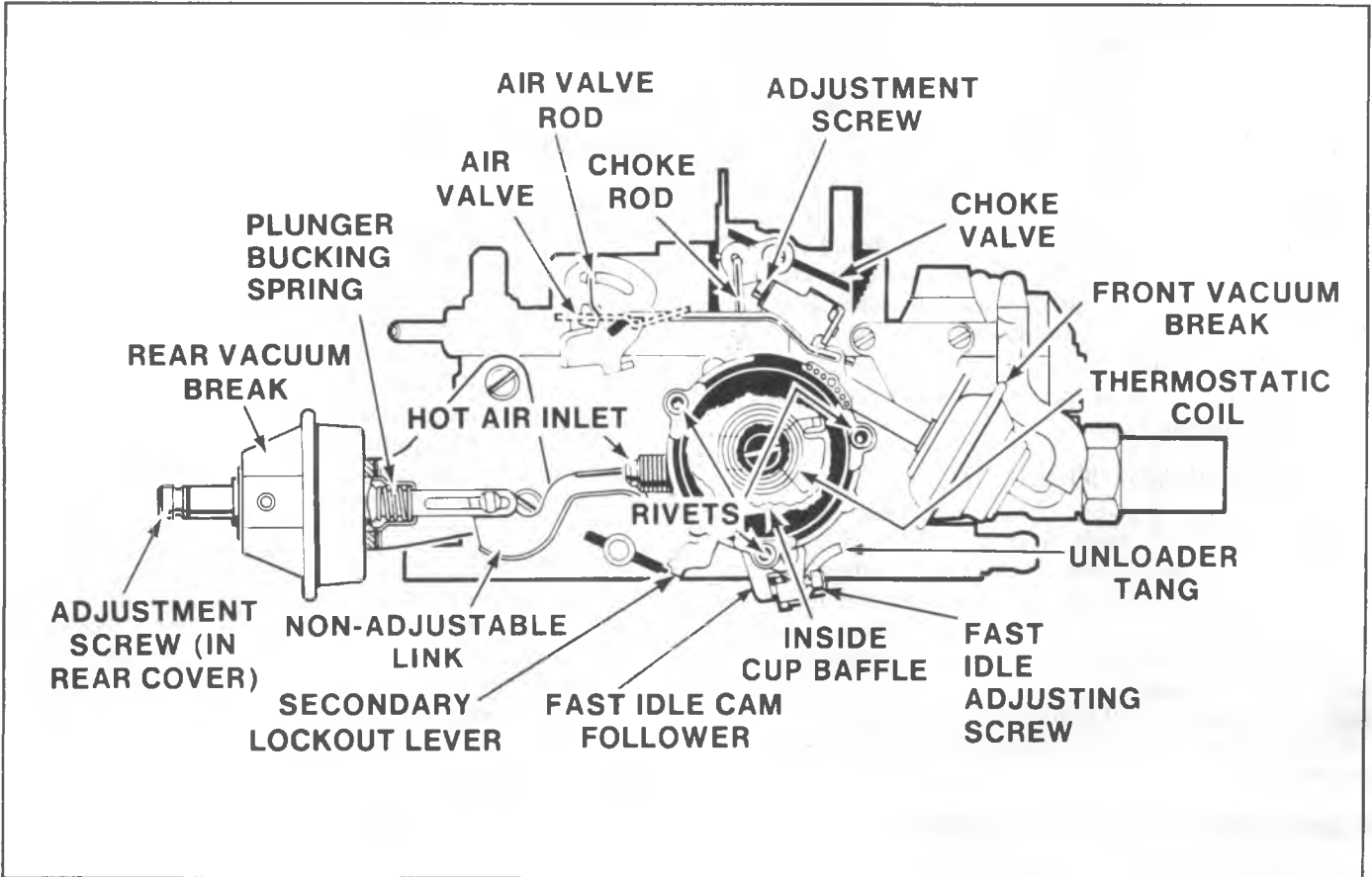

Fig. 6C10-8--Choke System - M4MC

## DIAGNOSIS

Refer to Engine Performance Diagnosis (Section 6), Fuel System Diagnosis (Section 6C) Emission Control System Diagnosis (Section 6E1) and/or Cleaning and Inspection under Unit Repair in this section.

## ON-VEHICLE SERVICE

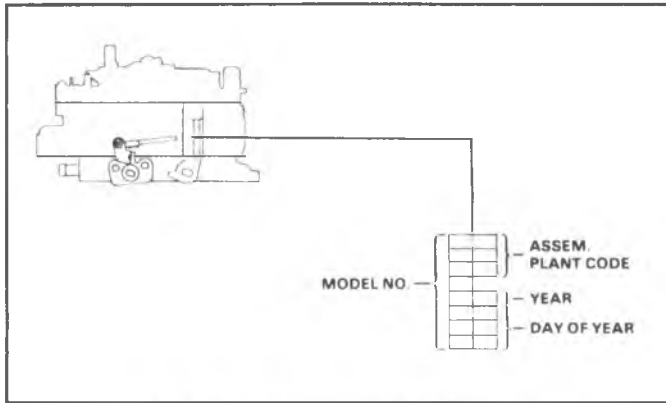

Fig. 6C10-9--Carburetor Identification

### GENERAL INFORMATION

A carburetor is designed to meet the particular requirements of the engine, transmission and vehicle and although they may look alike, they are not usually interchangeable. Refer to carburetor part number and/or specifications when making adjustments.

Before checking or resetting the carburetor as the cause of poor engine performance or rough idle; check ignition system including distributor, timing, spark plugs and wires. Check air cleaner, evaporative emission system, EFE System, PCV system, EGR valve and engine compression. Also inspect intake manifold, vacuum hoses and connections for leaks and check torque of carburetor mounting bolts/nuts. Make all adjustments with engine at normal operating temperature, choke full open, air cleaner installed. Except as noted air conditioning should be "off" and all vacuum lines and all electrical leads connected. Set parking brake and block drive wheels. Air cleaner can be removed for set-up accessibility but must be completely installed during actual setting.

Refer to the end of this section for special tools and adjustment specifications.

### CARBURETOR IDENTIFICATION

For ease of service, alphabetical code letters are included on the air horn, float bowl, and throttle body casting at external tube locations to identify hose connections. The carburetor model identification number is stamped vertically on the float bowl, near the secondary throttle lever (Fig. 6C10-9). Refer to the part number on the bowl when servicing the carburetor. When replacing the float bowl assembly, follow the instructions contained in the service package. Stamp or engrave the model number on the new float bowl.

### FLOAT MECHANICAL LEVEL CHECK

The float level can be checked without removing the air horn by using float gage J-9789-130/ or equivalent and

following external float level checking procedures in Figures 6C10-10.

### FAST IDLE ADJUSTMENT

Refer to the Vehicle Emission Control Information label and Figure 6C11-10 for fast idle adjustment.

### IDLE SPEED ADJUSTMENT

Refer to Figure 6C10-12 and Vehicle Emission Control Information label for idle speed adjustment without air conditioning.

Refer to Figure 6C10-13 and Vehicle Emission Control Information label for idle speed adjustment with air conditioning.

Refer to Figure 6C10-14 and Vehicle Emission Control Information label for throttle lever actuator assembly.

### CHOKE AND HOSES

Check choke mechanism and vacuum break for proper operation at the recommended maintenance intervals. Any binding condition which may have developed due to petroleum gum formation on the choke shaft or from damage should be corrected. Check carburetor hoses for proper connection, cracking, abrasion or deterioration and correct or replace as necessary.

Use vacuum device J-23738/BT-7517 or equivalent to check vacuum break.

### CARBURETOR CHOKE CHECK

#### General Procedure

1. Remove air cleaner. With engine off, hold throttle half open. Open and close choke several times. Watch linkage to be certain all links are connected and there are no signs of damage.
2. If choke or linkage binds, sticks or works sluggish, clean with choke cleaner X-20-A or equivalent. Use cleaner as directed on can. Refer to Unit Repair instructions for additional direction if cleaning does not correct. 3. Visually inspect carburetor to be certain all vacuum hoses are connected. Inspect hoses for cracks, abrasions, hardness or other signs of deterioration. Replace or correct as necessary.
4. Make sure vacuum break diaphragm shaft is fully extended when engine is off. If shaft is not fully extended, replace vacuum break assembly. Shaft should fully retract within 10 seconds after starting engine. If unit fails to retract, replace vacuum break assembly.

#### Checking Electric Choke

This check should be performed at an ambient temperature of 60 to 80°F (15 to 27°C).

1. Allow choke to cool so that when throttle is opened

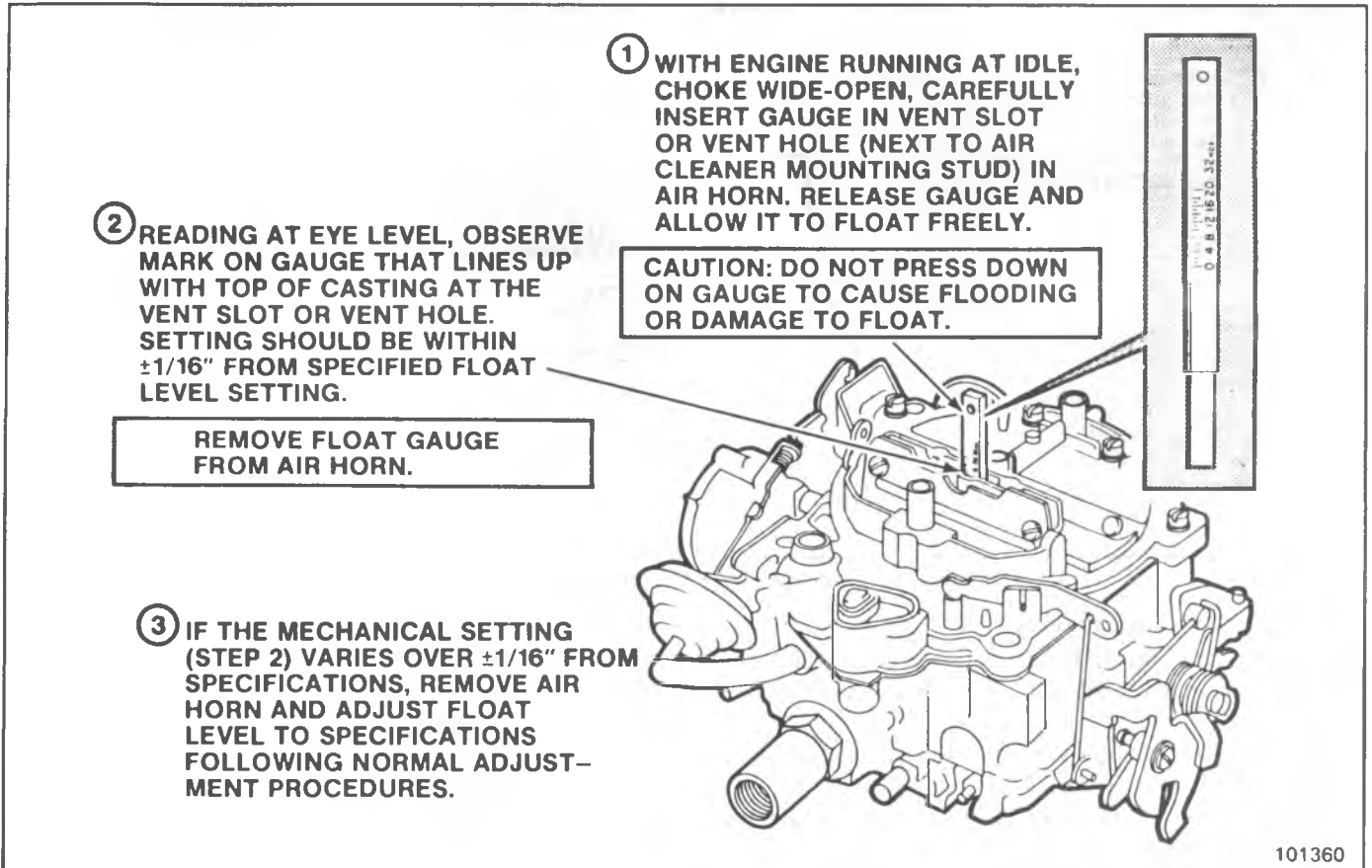

Fig. 6C10-10--External Float Level Check

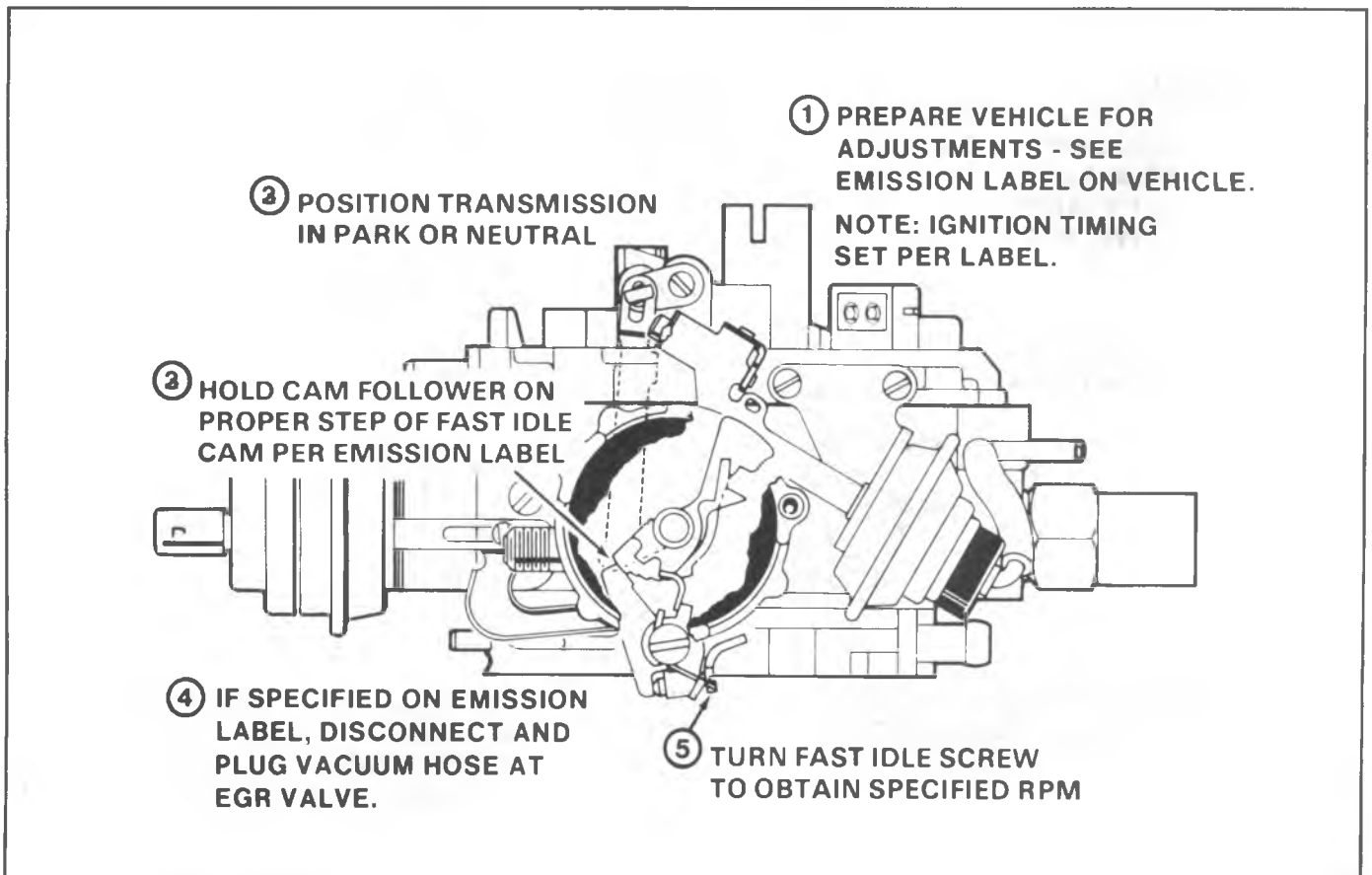

Fig. 6C10-11--Fast Idle Adjustment

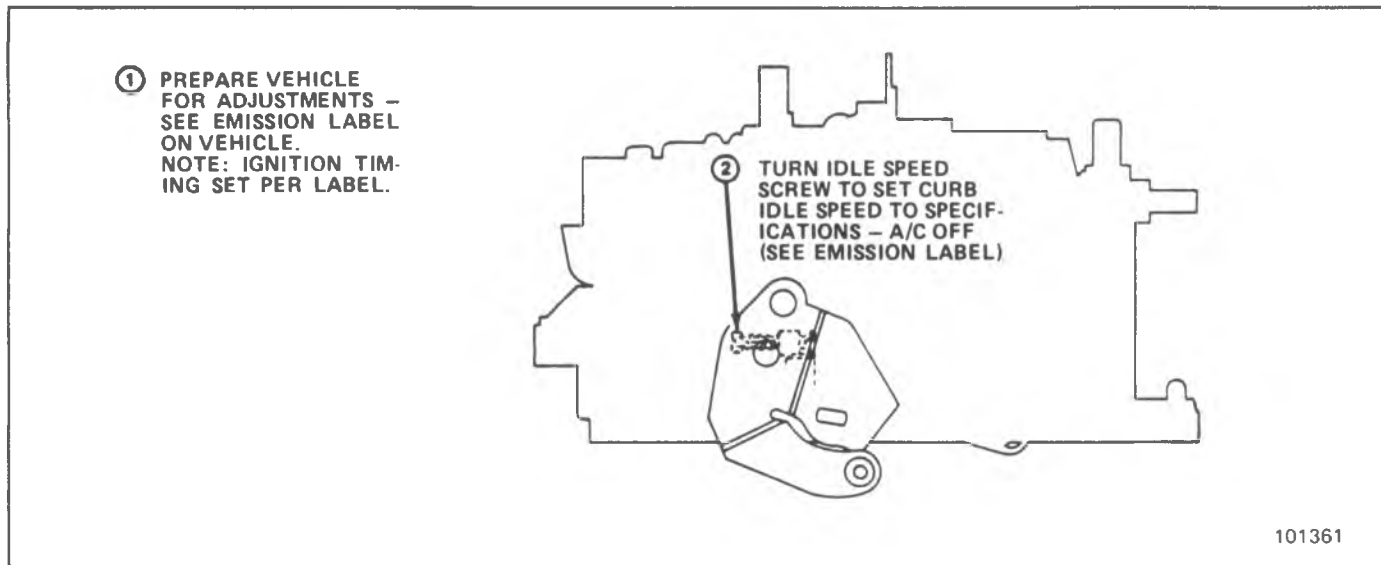

Fig. 6C10-12--Idle Speed Adjustment-Without A/C

slightly choke blade fully closes.

2. Start engine and determine time for choke blade to reach full open position. (Start timer when engine starts).
3. If the choke blade fails to open fully within 3.2 minutes, proceed with steps 4 and 5 below.
4. Check voltage at the choke heater connection: (Engine must be running).
  - a. If the voltage is approximately 12-15 volts, replace the electric choke unit.

- b. If the voltage is low or zero, check all wires and connections. Repair wires or replace fuses as required.

#### Checking Hot Air Choke

1. With parking brake applied, drive wheels blocked, transmission in Park or Neutral, start engine and allow engine to warm up, visually checking to be certain choke valve opens fully.
2. If choke valve fails to open fully, momentarily touch choke housing and hot air inlet pipe or hose to

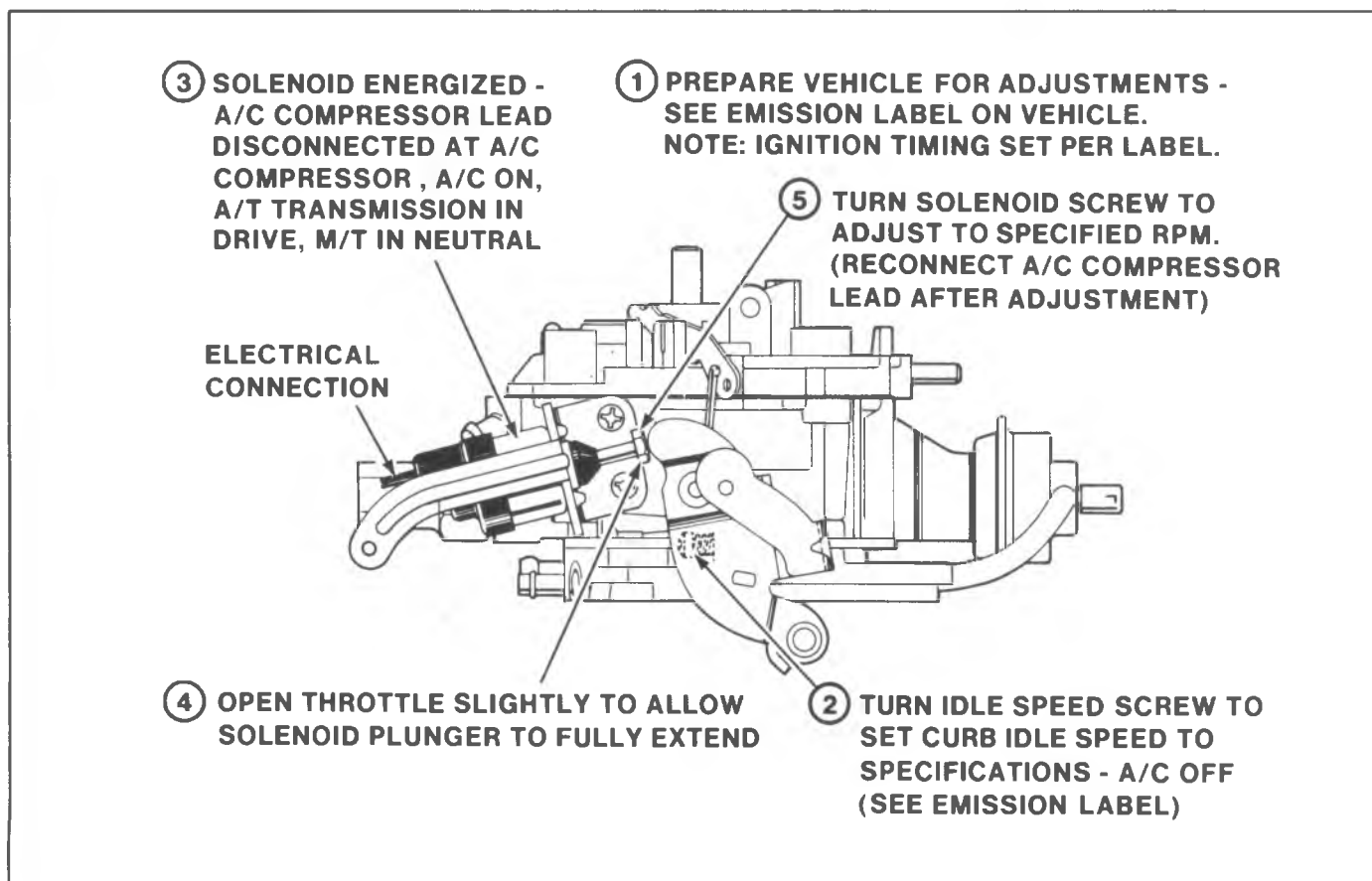

Fig. 6C10-13--Idle Speed Adjustment-With A/C

**NOTE: ENGINE MUST BE WARM -  
CHOKE WIDE OPEN - CAM FOLLOWER  
OFF STEPS OF FAST IDLE CAM.**

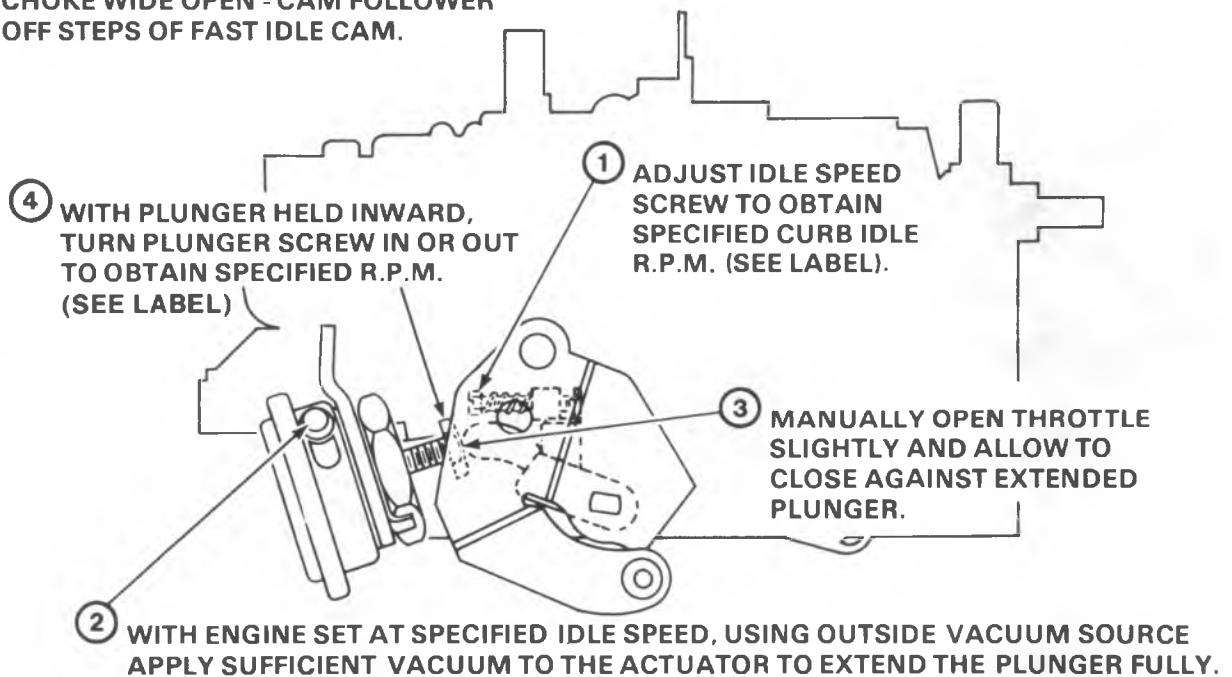

Fig. 6C10-14--Throttle Lever Actuator Adjustment

determine if sufficient heat is reaching the choke coil.

**CAUTION:** The choke housing and hot air inlet pipe or hose are "Hot" to the touch. Use care to prevent burning of hands.

3. If choke housing and/or heat inlet are cool to the touch, check for loss of vacuum to the housing, restricted heat inlet in the choke housing or choke heat pipe, collapsed or deteriorated heat inlet hose, or restricted passages in the manifold choke heat stove. Replace or correct as necessary.

#### IDLE SPEED SOLENOID CHECK

1. Turn on ignition, but do not start engine.
2. Turn A/C to "on" position.
3. Open throttle to allow solenoid to extend, close throttle.
4. Disconnect lead at solenoid. Solenoid plunger should drop away from throttle lever.
5. Connect solenoid lead. Plunger should move out and contact the throttle lever. Solenoid may not be strong enough to open the throttle, but the plunger should move.
6. If plunger does not move in and out as lead is disconnected and connected, insert test light (1893 bulb or smaller) between the solenoid feed wire and ground.
7. If light lights, replace solenoid.
8. If light does not light, locate cause of open circuit in solenoid feed wire.

#### IDLE MIXTURE CHECK AND ADJUSTMENT (PROPANE ENRICHMENT)

##### Light Duty Emission Vehicles Only

Idle mixture needles have been preset at the factory and sealed. Idle mixture should be adjusted only in the case of major carburetor overhaul, throttle body replacement or high emissions as determined by official inspections. Adjusting mixture by other than the following method may violate Federal and/or California or other state or Provincial laws. Because of the sealed idle mixture needles, the idle mixture checking procedure requires artificial enrichment by adding propane.

1. Set parking brake and block drive wheels.  
Engine must be at normal operating temperature and air conditioning off.
2. Disconnect and plug hoses as directed on the Emission Control Information label under the hood.
3. Connect an accurate tachometer to engine.
4. Disconnect vacuum advance and set timing to specification shown on the Vehicle Emission Control Information label. Re-connect vacuum advance.
5. Set carburetor idle speed to specification as shown on Vehicle Emission Control Information label.
6. Disconnect crankcase ventilation tube from air cleaner.
7. Using tool J-26911/BT-7816, insert hose with rubber stopper, from propane valve into crankcase ventilation tube opening in air cleaner. Propane cartridge must be vertical (Fig. 6C10-15).



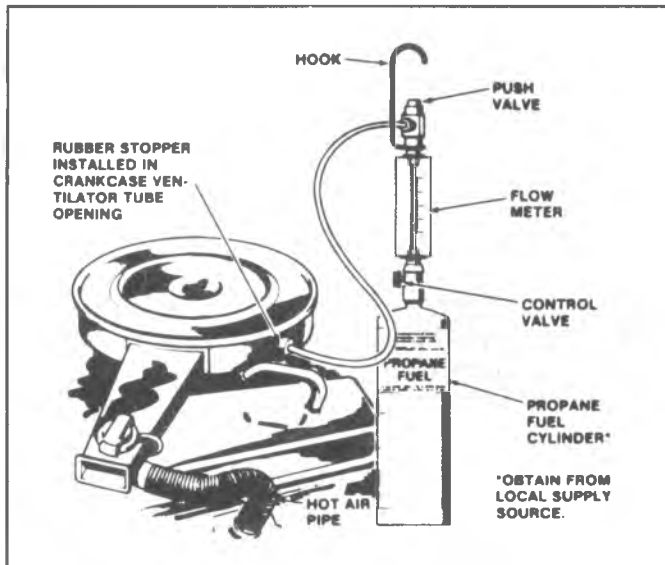

Fig. 6C10-15--Idle Mixture Choke-Propane Enrichment

8. With engine idling in drive (neutral for manual shifts) slowly open propane control valve while pressing button. Continue to add propane until speed drops due to over richness. Note maximum engine speed (enriched speed).

If rich speed drop cannot be obtained check for empty cartridge or propane system leaks.

9. If the enriched idle speed is within the enriched idle specification the mixture is correct. Go to step 17.
10. If the enriched idle speed is not within specifications, remove mixture screw plugs as follows:
  - a. Remove carburetor from engine, following normal service procedures, to gain access to the plugs covering the idle mixture needles.
  - b. Invert carburetor and drain fuel in container.
  - c. Place carburetor on a suitable holding fixture-manifold side up.
 

Use care to avoid damaging linkage, tubes, and parts protruding from air horn.
  - d. Make two parallel cuts in the throttle body on either side of the locator points beneath the idle mixture needle plug (manifold side) with a hack saw (Fig. 6C10-16). The cuts should reach down to the steel plug but should not extend more than 1/8" beyond the locator points. The distance between the saw marks depends on the size of the punch to be used.
  - e. Place a flat punch at a point near the ends of the saw marks in the throttle body. Holding the punch at a 45° angle, drive it into the throttle body until the casting breaks away, exposing the steel plug.
  - f. Holding a center punch vertical, drive it into the steel plug. Then holding the punch 45° angle, drive the plug out of the casting.

Hardened plug will break rather than remaining intact. It is not necessary to remove the plug completely; instead, remove loose pieces.

- g. Repeat procedure for the remaining mixture needle.

11. Using tool J 29030/BT-76108 or equivalent, lightly seat mixture needles, then back out equally, just enough so engine will run.
12. Place transmission in Drive (automatic) or Neutral (manual).
13. Back each screw out (richen 1/8 turn at a time until maximum idle speed is obtained). Then set idle speed to the enriched idle specification.
14. Turn each mixture screw in (clockwise) 1/8 turn at a time until idle speed reaches value given on Emission Control Information label.
15. Re-check enriched speed with propane. If not within specification, repeat adjustment beginning with Step 12.
16. After adjustments are complete, seal the idle mixture needle setting using silicone sealant RTV rubber or equivalent. The sealer is required to prevent tampering with the setting and to prevent the possibility of loss of fuel vapors.
17. Check and, if necessary, adjust fast idle as described on Emission Control Information label.
18. Turn off engine. Remove propane tool, connect crankcase ventilation tube. Unplug and reconnect vacuum hoses. Install air cleaner.
19. Remove blocks from drive wheels.

## IDLE MIXTURE ADJUSTMENT - BEST IDLE METHOD

### Heavy Duty Emission Vehicles Only

Idle mixture needles have been preset at the factory and sealed. Idle mixture should be adjusted only in the case of major carburetor overhaul, throttle body replacement, or high emissions as determined by official inspections.

If necessary, remove idle needle plugs (See Idle Mixture Needle Plug Removal procedure listed under Light Duty Emission Vehicles).

Perform this adjustment with engine at operating temperature, parking brake applied, drive wheels blocked and

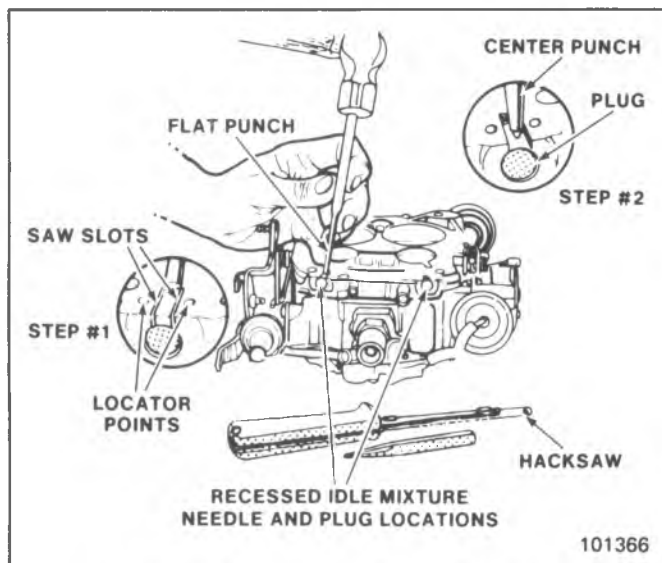

Fig. 6C10-16--Removing Idle Needle Plug-Typical

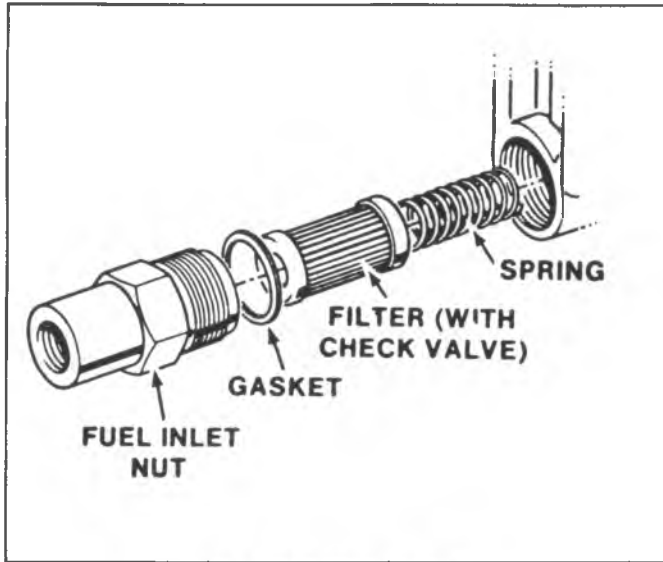

Fig. 6C10-17--Fuel Filter

transmission in park or neutral.

1. Remove air cleaner.
2. Connect tachometer and vacuum gage to engine.
3. As a preliminary adjustment, turn idle mixture needles in lightly to seat and back out 2 turns.

**NOTICE:** Do not turn idle mixture needle tightly against seat or damage may result.

4. With engine running (choke wide open and transmission in neutral) adjust idle speed screw to idle speed specified on Vehicle Emission Control Information label.
5. Adjust each idle mixture needle to obtain highest RPM.
6. Repeat steps 4 and 5 until "best" idle is obtained.
7. If necessary, reset curb idle speed to specifications on underhood label.
8. After adjustments are complete, seal the idle mixture needle setting using silicone sealant RTV rubber or equivalent. The sealer is required to prevent tampering with the setting and to prevent the possibility of loss of fuel vapors.
9. Check and, if necessary, adjust throttle lever actuator.
10. Check and, if necessary, adjust fast idle speed as described on Emission Control Information label.
11. Turn off engine, remove gages, unplug and reconnect vacuum hoses. Install air cleaner.
12. Remove block from drive wheels.

### FUEL FILTER REPLACEMENT

A plugged fuel filter will restrict fuel flow into carburetor and will result in a loss of engine power.

1. Remove air cleaner.
2. Disconnect fuel line connection at inlet fuel filter nut.
3. Remove inlet fuel filter nut from carburetor.
4. Remove filter and spring (Figure 6C10-17).

5. Install spring and filter element in carburetor with hole in filter toward nut.
6. Install new gasket on inlet fitting nut and install nut in carburetor and tighten to 34 N·m (300 in. lbs.).
7. Install fuel line and tighten connector to 24 N·m (18 ft. lbs.) while holding fuel inlet fitting with wrench.
8. Run engine and observe for leaks.

### CARBURETOR MOUNTING TORQUE

When torquing carburetor after removal overhaul, replacement or when installing a new heat insulator, torque mounting bolts, in a clockwise direction, to 16 N·m (144 in. lbs.). When retorquing carburetor at recommended maintenance intervals, check in clockwise direction. If less than 7 N·m (60 in. lbs.), retorque to 11 N·m (96 in. lbs.); if greater than 7 N·m (60 in. lbs.), do not retorque.

### CARBURETOR REPLACEMENT

#### Removal

Flooding, stumble on acceleration and other performance complaints are in many instances, caused by presence of dirt, water, or other foreign matter in carburetor. To aid in diagnosis, carburetor should be carefully removed from engine without draining fuel from bowl. Contents of fuel bowl may then be examined for contamination as carburetor is disassembled. Check filter.

1. Remove air cleaner and gasket.
2. Disconnect wire at solenoid, if equipped.
3. Disconnect fuel pipe and vacuum lines.
4. Disconnect choke system (Fig. 6C10-18).
5. Disconnect accelerator linkage.
6. If equipped with automatic transmission, disconnect downshift cable.
7. If equipped with cruise control, disconnect linkage.
8. Remove carburetor attaching bolt, carburetor and insulator.

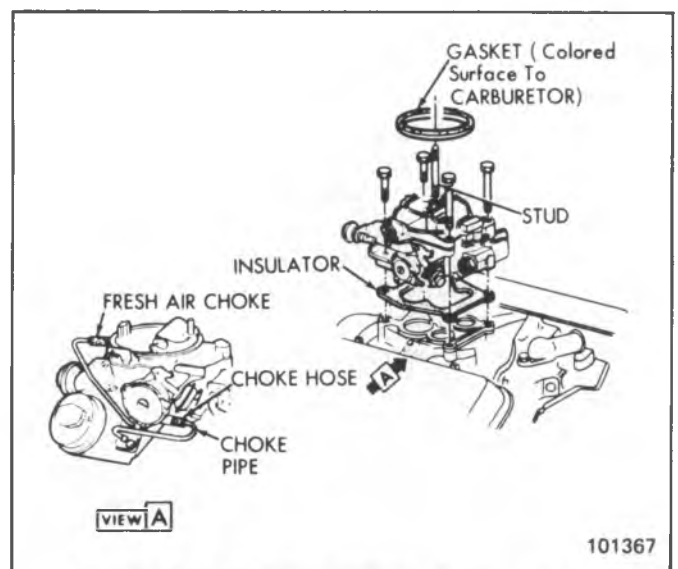

Fig. 6C10-18--Carburetor and Choke Pipes-M4MC

## Installation

1. Clean sealing surfaces on intake manifold and carburetor.
2. Fill carburetor bowl before installing carburetor.
3. Install carburetor with new insulator and tighten bolts to correct torque (See Carburetor Mounting Torque).
4. Connect downshift cable as required.

5. Connect cruise control cable as required.
6. Connect accelerator linkage.
7. Connect choke system.
8. Connect fuel pipe and vacuum hoses.
9. Connect solenoid as required.
10. Install air cleaner.
11. Check and adjust idle speed.

## UNIT REPAIR

### GENERAL

The procedures that follow apply to a complete carburetor overhaul with the carburetor removed from the engine. Refer to Figures 6C10-19 and 6C10-20 for part identification during disassembly and assembly of carburetor components. In many cases, service adjustments of individual systems may be completed without removing the carburetor from the engine (refer to "On-Vehicle Service").

A complete carburetor overhaul includes disassembly, thorough cleaning, inspection and replacement of all gaskets, diaphragms, seals, worn or damaged parts and service adjustment of individual system, plus restoring tamper-resistant features where applicable.

### DISASSEMBLY

Place carburetor on a holding fixture J 9789-118, BT-30-15, or equivalent to prevent damage to throttle valves.

#### Idle Speed Solenoid (ISS) (If Equipped)

Remove attaching screws and remove idle speed solenoid from float bowl.

The solenoid should not be immersed in carburetor cleaner and should always be removed before complete carburetor overhaul. Carburetor cleaner will damage the internal parts.

### Air Horn

#### Removal

1. Remove upper choke lever from the end of choke shaft by removing retaining screw. Then rotate lever to remove choke rod from slot in lever.
2. Remove choke rod from lower (inner) choke lever inside the float bowl casting. Remove rod by holding lower lever outward with small screwdriver and twisting rod counterclockwise.
3. Remove secondary metering rods by removing the small screw in the top of the metering rod hanger, then lifting up on the metering rod hanger until the secondary metering rods are completely out of the air horn. Metering rods may be disassembled from the hanger by rotating ends out of the holes in the end of the hanger.
4. Using tool J-25322/, drive small roll pin (pump lever pivot pin) inward just until pump lever can be removed from air horn. Remove pump lever from pump rod (Fig.

6C10-21). Note location of pump rod for reassembly. Use care when driving small roll pin to prevent damage to pump lever casting bosses on air horn.

5. Remove front (primary) vacuum break hose from tube on float bowl noting tube location for reassembly later.
6. Remove eleven air horn-to-bowl screws; then remove the two countersunk attaching screws (Number 1 and 2) located next to the venturi (Fig. 6C10-22). If used, remove secondary air baffle deflector from beneath the two center air horn screws (Numbers 3 and 4).
7. Remove air horn from float bowl by lifting straight up. The air horn gasket should remain on the float bowl for removal later.

When removing air horn from float bowl, use care to prevent damage to the small tubes protruding from the air horn. These tubes are permanently pressed into the air horn casting. **DO NOT REMOVE THEM.**

### Air Horn

#### Disassembly

1. Remove front vacuum break bracket attaching screws. The vacuum break assembly may now be removed from the air valve rod and the rod from the air valve lever.  
**NOTICE:** Do not place vacuum break assembly in carburetor cleaner. Carburetor cleaner will damage internal parts.
2. If used, remove pump plunger stem seal by inverting air horn and, using a small screwdriver, remove staking holding the seal retainer in place (Fig. 6C10-23). Remove and discard retainer and seal. Use care in removing the pump plunger stem seal retainer to prevent damage to air horn casting. A new seal and retainer are required for reassembly.
3. Further disassembly of the air horn is not required for cleaning purposes. The choke valve and choke valve screws and air valve and air valve shaft should not be removed. However, if it is necessary to replace the air valve closing spring or center plastic eccentric cam, a repair kit is available. Instructions for assembly are included in the repair kit.

### Float Bowl

#### Disassembly

1. Remove air horn gasket by lifting out of dowel locating pins and lifting tab of gasket from beneath the power piston hanger, being careful not to distort springs holding the main metering rods. Discard



**AIR HORN PARTS**

- 1 - Air Horn Assy.
- 2 - Gasket - Air Horn
- 3 - Lever - Pump Actuating
- 4 - Roll Pin - Pump Lever Hinge
- 5 - Screw - Air Horn Long (2)
- 6 - Screw - Air Horn Short ( )
- 7 - Screw - Air Horn Countersunk (2)
- 8 - Metering Rod - Secondary (2)
- 9 - Holder and Screw - Secondary Metering Rod
- 10 - Baffle - Secondary Air
- 11 - Seal - Pump Plunger
- 12 - Retainer - Pump Seal

**CHOKE PARTS**

- 13 - Vac. Break Control & Bracket - Front
- 14 - Screw - Control Attaching (2)
- 15 - Hose - Vacuum
- 16 - Rod - Air Valve
- 16A - Rod - Air Valve (Truck)
- 17 - Lever - Choke Rod (Upper)
- 18 - Screw - Choke Lever
- 19 - Rod - Choke
- 20 - Lever - Choke Rod (Lower)
- 21 - Seal - Intermediate Choke Shaft
- 22 - Lever - Secondary Lockout
- 23 - Link - Rear Vacuum Break
- 24 - Int. Choke Shaft & Lever
- 25 - Cam - Fast Idle
- 26 - Seal - Choke Housing to Bowl (Hot Air Choke)
- 27 - Kit - Choke Housing
- 28 - Screw - Choke Housing to Bowl
- 29 - Seal - Intermediate Choke Shaft (Hot Air Choke)
- 30 - Lever - Choke Coil
- 31 - Screw - Choke Coil Lever
- 32 - Gasket - Stat Cover (Hot Air Choke)
- 33 - Stat Cover & Coil Assy. (Hot Air Choke)
- 34 - Stat Cover & Coil Assy. (Electric Choke)
- 35 - Kit - Stat Cover Attaching
- 36 - Rear Vacuum Break Assembly
- 37 - Screw - Vacuum Break Attaching (2)

**FLOAT BOWL PARTS**

- 38 - Float Bowl Assembly
- 39 - Jet - Primary Metering (2)

**FLOAT BOWL PARTS (Continued)**

- 40 - Ball - Pump Discharge
- 41 - Retainer - Pump Discharge Ball
- 42 - Baffle - Pump Well
- 43 - Needle & Seat Assembly
- 44 - Float Assembly
- 45 - Hinge Pin - Float Assembly
- 46 - Power Piston Assembly
- 47 - Spring - Power Piston
- 48 - Rod - Primary Metering (2)
- 49 - Spring - Metering Rod Retainer
- 50 - Insert - Float Bowl
- 51 - Insert - Bowl Cavity
- 52 - Spring - Pump Return
- 53 - Pump Assembly
- 54 - Rod - Pump
- 55 - Baffle - Secondary Bores
- 56 - Idle Compensator Assembly
- 57 - Seal - Idle Compensator
- 58 - Cover - Idle Compensator
- 59 - Screw - Idle Compensator Cover (2)
- 60 - Filter Nut - Fuel Inlet
- 61 - Gasket - Filter Nut
- 62 - Filter - Fuel Inlet
- 63 - Spring - Fuel Filter
- 64 - Screw - Idle Stop
- 65 - Spring - Idle Stop Screw
- 66 - Idle Speed Solenoid & Bracket Assembly
- 67 - Idle Load Compensator & Bracket Assembly
- 68 - Bracket - Throttle Return Spring
- 69 - Actuator - Throttle Lever (Truck Only)
- 70 - Bracket - Throttle Lever Actuator (Truck Only)
- 71 - Washer - Actuator Nut (Truck Only)
- 72 - Nut - Actuator Attaching (Truck Only)
- 73 - Screw - Bracket Attaching (2)

**THROTTLE BODY PARTS**

- 74 - Throttle Body Assembly
- 75 - Gasket - Throttle Body
- 76 - Screw - Throttle Body (3)
- 77 - Idle Mixture Needle & Spring Assy. (2)
- 78 - Screw - Fast Idle Adjusting
- 79 - Spring - Fast Idle Screw
- 80 - Tee - Vacuum Hose
- 81 - Gasket - Flange

101369

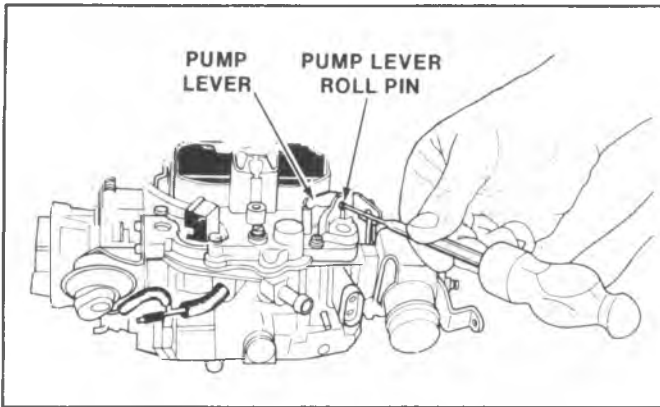

Fig. 6C10-21--Removing Pump Lever

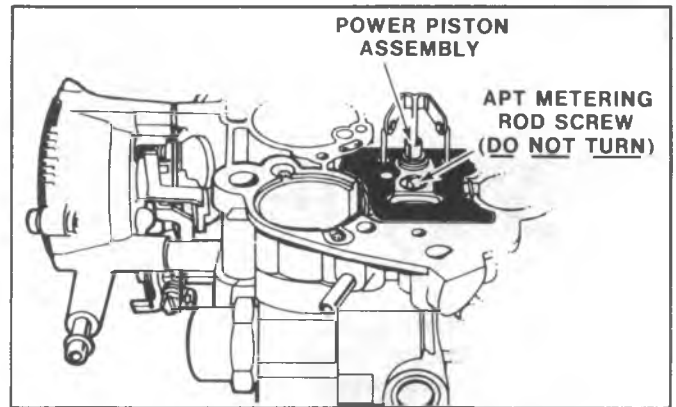

Fig. 6C10-24--APT Metering Rod Screw

Do not remove power piston by using pliers on metering rod hanger or pressed in hanger may come loose from piston.

- Remove the power piston spring from the well.

The A.P.T. metering rod adjustment screw, located in a well next to the power piston well (Fig. 6C10-24) is set at the factory and **no attempt** should be made to change the adjustment in the field. If float bowl replacement is required during service, the new float bowl will be supplied with an A.P.T. metering rod screw pre-set as required.

- Remove metering rods from power piston by disconnecting tension spring from top of each rod, then rotate rod to remove from hanger (Fig. 6C10-25).

Use care when disassembling rods to prevent distortion of tension spring and/or metering rods. Note carefully position of tension spring for later reassembly.

- Remove plastic filler block over float chamber.
- Remove float assembly and float needle by pulling up on retaining pin. Remove float needle seat and gasket using seat remover J 22769, BT-3006M, or equivalent.
- If used, remove plastic insert cavity in float bowl.
- If necessary, remove primary main metering jets.

**NOTICE:** No attempt should be made to remove the

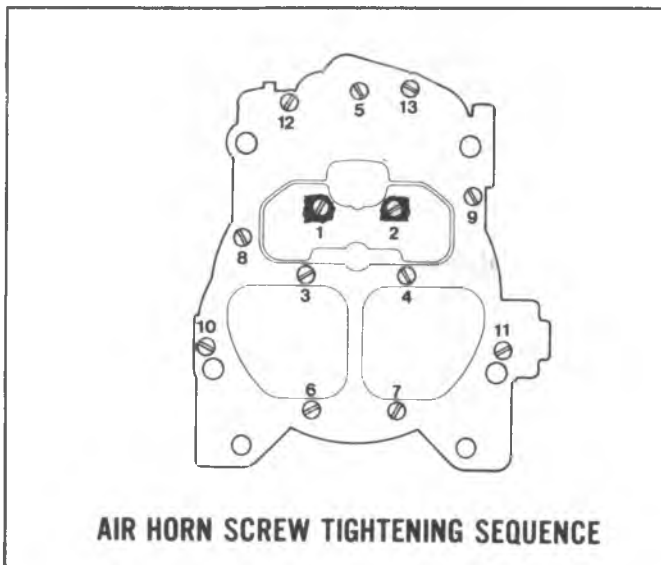

**AIR HORN SCREW TIGHTENING SEQUENCE**

Fig. 6C10-22--Air Horn Screw Location

gasket.

- Remove pump plunger from pump well.
- Remove pump return spring from pump well.
- Remove power piston and metering rods by depressing piston stem and allowing it to snap free.

The power piston can be easily removed by pressing the piston down and releasing it with a snap. This will cause the power piston to snap the piston up against the retainer. This procedure may have to be repeated several times.

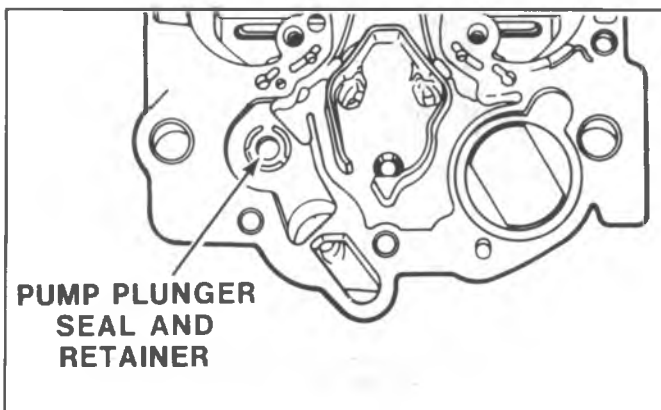

Fig. 6C10-23--Pump Plunger Stem Seal

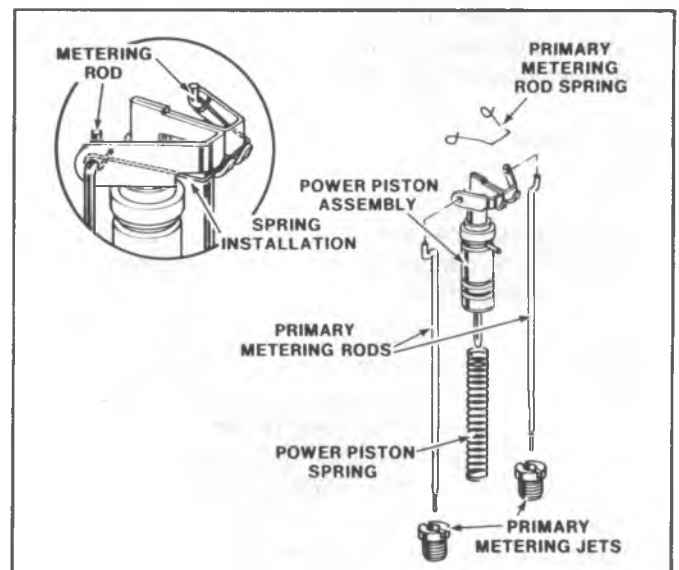

Fig. 6C10-25--Power Piston and Metering Rods

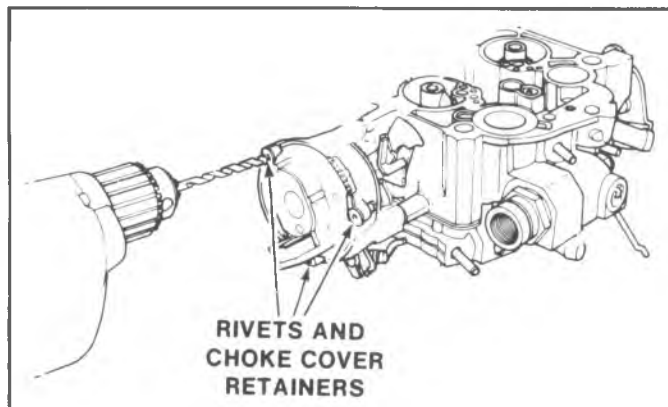

Fig. 6C10-26--Removing Choke Cover

secondary metering jet (metering orifice plates). These jets are fixed and, if damaged, replacement of the entire float bowl is required.

11. Remove pump discharge check ball retainer. Invert bowl and catch discharge ball as it falls from the bowl.
12. Remove secondary air baffle, if replacement is required.
13. Remove pump well fill slot baffle only if necessary.
14. Remove hoses from rear vacuum break assembly, where used. Remove (2) screws and rotate the assembly to remove vacuum break link from slot in plunger head and, if used, air valve rod. On M4ME, the non-adjustable vacuum break link, is not removed at this time, but is removed after the removal of the choke assembly from the float bowl.

**NOTICE:** Do not place vacuum break assembly in carburetor cleaner because it will damage internal parts.

## Choke

### Disassembly

The tamper-resistant choke cover is used to discourage unnecessary readjustment of the choke thermostatic cover and coil assembly in the field. However, it is necessary to remove the cover and coil assembly during normal carburetor disassembly for cleaning and overhaul the procedures should be followed.

### Choke Cover

#### Removal

1. Support float bowl and throttle body as an assembly, on a suitable holding fixture such as Tool J 9789-118, BT-30-15, or equivalent.
2. Carefully align a #21 drill (.159") on rivet head and drill only enough to remove rivet head (Fig. 6C10-26). Drill the two (2) remaining rivet heads and then use a drift and small hammer to drive the remainder of the rivets out of the choke housing. Use care in drilling to prevent damage to choke cover or housing.
3. Remove the three retainers, choke cover gasket (if used), and choke cover assembly from choke housing.

Do not remove baffle plate from beneath the thermostatic coil on the choke cover (hot air choke model).

4. Remove choke housing assembly from float bowl by removing retaining screw and washer inside the choke housing (Fig. 6C10-27). The complete choke assembly can be removed from the float bowl by sliding outward.
5. Remove plastic tube seal (hot air models only) from vacuum inlet boss on choke housing.  
Do not immerse the plastic tube seal in carburetor cleaner.
6. If used, remove rear (auxiliary) vacuum break link from intermediate choke lever.
7. Remove secondary throttle valve lockout lever from float bowl (6C10-27).
8. Remove lower (inside) choke lever from inside float bowl cavity by inverting bowl.
9. To disassemble intermediate choke shaft from choke housing, remove choke coil lever retaining screw at end of intermediate shaft and remove lever (Fig. 6C10-27). Remove intermediate choke shaft from the choke housing by sliding outward. The fast idle cam can now be removed from the intermediate choke shaft. On hot air models, remove the cup seal from inside choke housing shaft hole. Discard seal.
10. Remove the cup seal (from the intermediate choke shaft) from the float bowl insert for bowl cleaning purposes. **DO NOT ATTEMPT TO REMOVE PLASTIC INSERT.**

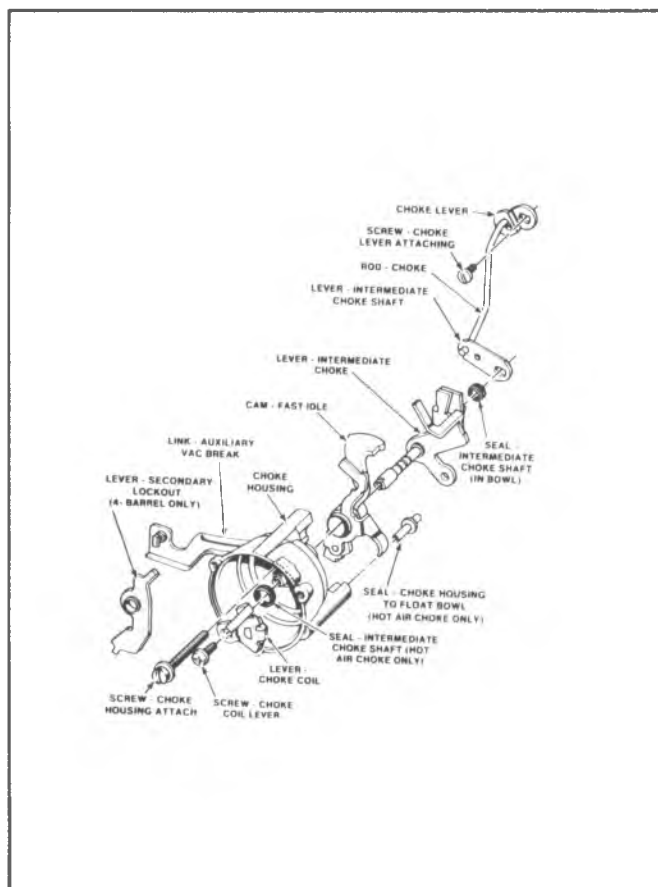

Fig. 6C10-27--Choke Assembly - Removal



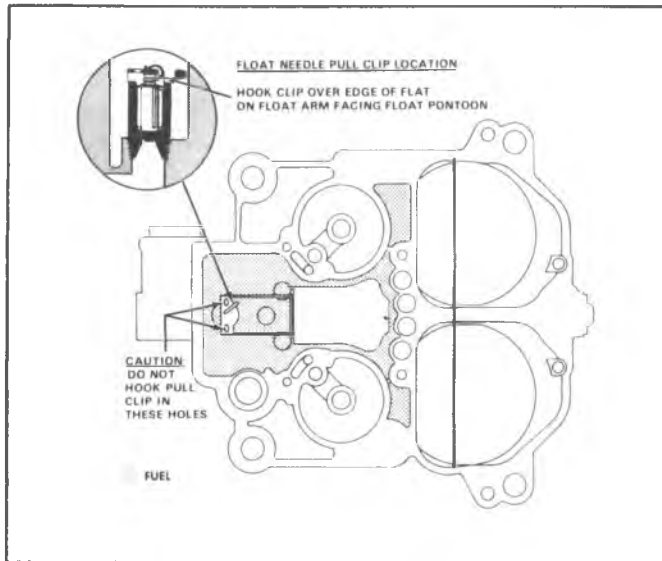

Fig. 6C10-28--Flood Needle Pull Clip Location

### Float Bowl

#### Disassembly

1. Remove fuel inlet nut, gasket and check valve filter assembly and spring.
2. Remove three throttle body to bowl attaching screws and lockwashers and remove throttle body assembly.
3. Remove throttle body to bowl insulator gasket.

### Throttle Body

#### Disassembly

Place throttle body assembly on carburetor holding fixture to avoid damage to throttle valves.

1. Remove pump rod from throttle lever by rotating rod until tang on rod aligns with slot in lever.
2. **Do not remove** plugs covering idle mixture needles during normal carburetor cleaning and servicing. Remove plugs only if diagnosis indicates the carburetor is the cause of a driver complaint or emission failure, or the idle mixture needles or throttle body must be replaced, in which case, the plugs may be removed and the idle mixture adjusted on the vehicle, carefully following "On-Vehicle Service" procedures.

If necessary to remove the idle mixture needles, see Idle Mixture Needle Plug Removal (Fig. 6C10-16).

Further disassembly of the throttle body is not required for cleaning purposes. The throttle valve screws are permanently staked in place and should not be removed. The throttle body is serviced as a complete assembly.

### CLEANING AND INSPECTION

Metal carburetor parts should be cleaned in cold immersion type cleaner, such as Carbon X (X-55) or its equivalent.

**NOTICE:** The electric solenoid, rubber parts, plastic parts, diaphragms, pump plunger, pump stem seal, etc. should not be put in immersion type cleaner as they will swell, harden or distort.

The plastic cam on the air valve shaft and bushing insert in bowl will withstand normal cleaning. Rinse thoroughly after cleaning.

1. Thoroughly clean all metal parts and blow dry with compressed air. Make sure all fuel passages and metering parts are free of burrs and dirt. Do not pass drills or wire through jets.
2. Inspect upper and lower surfaces of carburetor casting for damage.
3. Inspect holes in levers for excessive wear or out of round conditions. If worn, lever should be replaced.
4. Inspect plastic parts for cracks, damage, etc. Replace if necessary.
5. Check, repair or replace the following parts if the following problems were encountered.

#### a. Flooding

1. Inspect float needle seat for dirt, deep wear grooves, scores and in proper seating.
2. Inspect float needle pull clip for proper installation (Fig. 6C10-28). Be careful not to bend needle pull clip.
3. Inspect float, float arm and hinge pin for distortion, binds and burrs. Check density of material in the float, if heavier than normal, replace float.
4. Replace fuel inlet filter.

#### b. Hesitation

1. Inspect pump plunger for cracks, scores or excessive cup wear and replace plunger if necessary.
2. Inspect pump duration and return springs for being weak or distorted.
3. Check all pump passages and jets for dirt, improper seating of discharge ball and scores in pump well. Check condition of pump discharge check ball.
4. Check pump linkage for excessive wear. Repair or replace if necessary.

#### c. Hard Starting - Poor Cold Operation

1. Check choke valve and linkage for excessive wear, binds or distortion.
2. Inspect choke vacuum diaphragm for leaks.
3. Replace carburetor fuel filter.
4. Inspect float needle for sticking, dirt etc.
5. Examine fast idle cam for wear or damage.
6. Also check items under "Flooding".

#### d. Poor Performance - Poor Gas Mileage

1. Clean all fuel and vacuum passages in castings.
2. Check choke valve for freedom of movement.
3. Check power piston metering rods for dirt, sticking, binding, damaged parts or excessive wear.
4. Inspect primary metering jets for being dirty, loose, worn or damaged.
5. Check air valves for binds and damage. If air valve is damaged, the air horn assembly must be replaced. A torsion spring kit is available for repairs to air valve closing spring. A new plastic secondary metering rod cam is included



in the kit.

#### e. Rough Idle

1. Inspect gasket mating surfaces on castings for damage to sealing beads, nicks, burrs and other damage.
2. Clean all idle fuel passages.
3. If removed, inspect idle mixture needles for ridges, burrs, or being bent.
4. Check throttle lever and valves for binds, nicks, and other damage.
5. Check all diaphragms for possible ruptures or leaks.
6. Clean plastic parts only in cleaning solvent - never in gasoline.

### CHECK CARBURETOR CHOKE AND UNLOADER OPERATION AND ADJUSTMENT

**NOTICE:** Choke linkage and fast idle cam must operate freely. Bent, dirty or otherwise damaged linkage must be cleaned, repaired, or replaced as necessary. Do not lubricate linkage, as this will collect dust and cause sticking.

### CHECK FUEL LINES AND SERVICE FUEL FILTER

1. Inspect fuel lines for kinks, bends, or leaks and correct any defects found.
2. Replace filter in carburetor inlet, making sure type used includes the check valve in the filter inlet.

If a complaint of poor high speed performance exists on the vehicle, fuel pump tests should be performed.

### ASSEMBLY

#### Throttle Body

##### Assembly

1. Install lower end of pump rod in throttle lever by aligning tang on rod with slot in lever. End of rod should point outward toward throttle lever.
2. If removed, install idle and springs mixture needle and springs using Tool J-29030-B, BT-7610B, or equivalent. Lightly seat each needle and then back out 3 turns as a preliminary idle mixture adjustment. Final idle mixture adjustment must be on the engine using the procedures described under "On-Vehicle Service"

#### Float Bowl

##### Assembly

If a new float bowl assembly is used, stamp or engrave the model number on the new float bowl (Fig. 6C10-9).

1. Install new throttle body to bowl gasket over two locating dowels on bowl. 2. Install throttle body making certain throttle body is properly located over dowels on float bowl. Install throttle body to bowl screws and tighten evenly and securely. 3. Place carburetor on proper holding fixture such as J9789-118, BT-30-15 or equivalent. 4. Install fuel inlet filter spring, filter, a new check valve filter assembly, new gasket and inlet nut and tighten nut to 24 N·m (18 ft. lbs.).

When installing a service replacement filter, be sure the filter is the type that includes the check valve to meet government safety standards. New service replacement filters with check valve meet this requirement. When properly installed, hole in filter faces toward inlet nut. Ribs on closed end of filter element prevent filter from being installed incorrectly unless forced. Tightening beyond specified torque can damage inlet nut gasket to cause fuel leak.

### Choke Housing to Float Bowl

1. Install new cup seal into insert on side of float bowl for intermediate choke shaft. Lip on cup seal faces outward (Fig. 6C10-27).
  2. Install secondary throttle valve lockout lever on boss on float bowl with recess in hole in lever facing inward (Fig. 6C10-27).
  3. On hot air choke model, install new cup seal into choke shaft hole. Lips on seal face inward toward float bowl.
  4. Place fast idle cam on the intermediate choke shaft (with steps on fast idle cam facing downward). Install intermediate choke shaft in choke housing pushing shaft through seal in housing.
  5. Install choke coil lever on flats on intermediate chokeshaft, install retaining screw, and tighten securely (Fig. 6C10-27). Lever is properly aligned when both inside and outside levers face toward fuel inlet.
  6. If rear vacuum break link is used, install rear vacuum break link in hole in immediate choke shaft lever. The end of link faces toward choke housing when installed correctly.
  7. On hot air choke models, insert plastic tube seal (to float bowl) in vacuum inlet hole on choke housing (Fig. 6C10-25).
  8. Install lower (inner) choke lever in cavity in float bowl using Tool J-23417, BT-6911 or equivalent (Fig. 6C10-29). Install choke housing to bowl sliding intermediate choke shaft through bowl seal and into lower (inner) choke lever.
- The intermediate choke shaft lever and fast idle cam are in correct position when the tang on lever is beneath the fast idle cam.
8. Install choke housing retaining screw and washer (Fig. 6C10-27) and tighten securely. Check linkage for freedom of movement.

Do not install the choke cover and coil assembly until completion of adjustments (starting at Figure 6C10-34).

### Float Bowl

#### Completion of Assembly

1. On all models, except those using an air valve rod to the rear vacuum break, install end of vacuum break link in slot in rear vacuum break plunger. Install vacuum break and bracket assembly on float bowl using two large countersunk attaching screws. Tighten securely.
2. If removed, install air baffle in secondary side of float bowl with notches toward the top. Top edge of

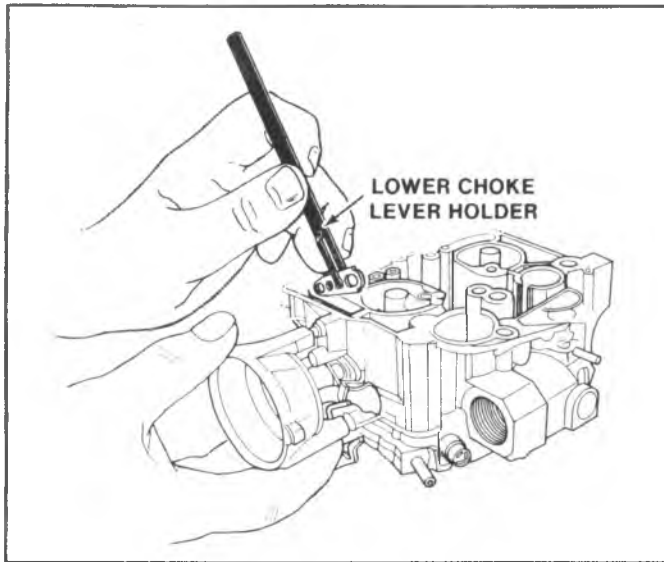

Fig. 6C10-29--Installing Lower Choke Lever

baffle must be flush with bowl casting.

3. If removed, install baffle in side of pump well with slot at bottom.
4. Install pump discharge check ball and retainer screw in passage next to pump well. Tighten retainer screw securely.
5. If removed, carefully install primary metering jets in bottom of float bowl. Jets should be seated securely in bowl-do not overtighten.
6. Install plastic insert, if used, into cavity in float bowl.
7. Install needle seat assembly, with gasket, using seat installer J-22769, BT-3006M or equivalent.
8. To make adjustment easier, carefully bend float arm upward at notch in arm before assembly.
9. Install float needle onto float arm by sliding float lever under needle pull clip. Proper installation of the needle pull clip is to hook the clip over the edge of the float on the float arm facing the float pontoon (Fig. 6C10-28).
10. Install float hinge pin into float arm with end of loop of pin facing pump well. Install float assembly by aligning needle in the seat and float hinge pin into locating channels in the float bowl. **Do not** install float needle pull clip into holes in float arm or flooding may result. See Figure 6C10-28 for correct needle pull clip location.
11. Perform **Float Level Adjustment** referring to Figure 6C10-31.
12. Install plastic filler block over float needle, pressing downward until properly seated.
13. Install power piston spring in power piston well.
14. If metering rods were removed from hanger, reinstall making sure tension spring is connected to top of each rod (Fig. 6C10-25). Install power piston assembly in well (aligning pin on piston with slot in well) and with metering rods properly position in metering jets. Press down firmly on plastic power piston retainer to make sure the retainer is seated in recess in bowl and the top is flush with the top of the bowl casting. If necessary,

using a drift punch and small hammer, tap retainer in place lightly.

15. Install pump return spring in pump well.
16. Install air horn gasket by sliding tab of gasket carefully around main metering rods and beneath the power piston hanger. Position gasket over the two dowel pins on the float bowl.
17. Carefully lift one corner of the air horn gasket and install pump plunger in the pump well by pushing the plunger to the bottom of the well against return spring tension. While holding in this position, align pump plunger stem with hole in gasket and press gasket in place.

## Air Horn

### Assembly

1. Apply a liberal quantity of a lithium base grease to the air valve shaft pin (Figure 6C10-23), making sure to lubricate pin surface contacted by the closing spring.
2. If used, install new pump plunger stem seal and retainer in air horn casting (Fig. 6C10-17). The lip on the seal faces outward, away from air horn mounting surface. Lightly stake seal retainer in three places, choosing locations different from the original stakings.

### Air Horn to Bowl

#### Installation

1. Holding down on air horn gasket at pump plunger location, carefully lower air horn assembly onto float bowl. Be sure that the bleed tubes, pull-over enrichment tubes (if used) and pump plunger stem are positioned properly through the holes in the air horn gasket.  
Do not force the air horn assembly onto the bowl but rather lightly lower in place.
2. Install eleven air horn attaching screws and lockwashers; and two countersunk screws (Nos. 1 2) located next to the carburetor venturi area. If used, install secondary air baffle deflector under air horn screws **3 and 4**. **Tighten all screws evenly and securely following air horn screw tightening sequence (Fig. 6C10-22).**
3. On models using a single rear vacuum break, install air valve rod in air valve lever. Install end of air valve rod and vacuum break link in slots in vacuum break plunger. Install vacuum break and bracket assembly on float bowl using too large countersunk attaching screws. Tighten screws securely. If vacuum break adjustment is necessary, see adjustment.procedure (Fig. 6C10-39).
4. On models using a front vacuum break, install air valve rod into slot in air valve lever. Install the other end of rod in hole in front vacuum break diaphragm plunger. Install vacuum break on air horn using two attaching screws. Tighten screws securely. If vacuum break adjustment is necessary, see adjustment. procedure (Fig. 6C10-38).
5. Connect upper end of pump rod to pump lever by placing rod in specified hole in lever, noted at disassembly. Align hole in pump lever with hole in

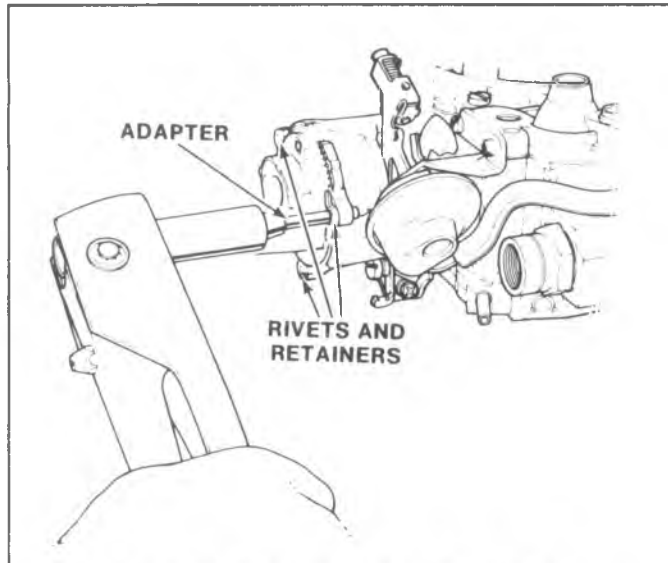

Fig. 6C10-30—Installing Choke Cover Rivets

air horn casting using J-25322 or equivalent. Using screwdriver, push pump lever roll pin back through casting until end of pin is flush with casting bosses in air horn.

Use care installing the roll pin to prevent damage to pump lever bearing surface and casting bosses.

6. Install two secondary metering rods into the secondary metering rod hanger (upper end of rods point toward each other). Install secondary metering rod hanger, with rods, onto air valve cam follower. Install retaining screw and tighten securely. Work air valves up and down several times to make sure they move free in all positions.
7. Connect choke rod into lower choke lever inside bowl cavity. Install choke rod into slot in upper choke lever and position lever on end of choke shaft. Install retaining screw and tighten securely. When properly installed, the lever will point to the rear of the carburetor and the number on the lever will face outward.
8. Perform adjustments indicated below, which will be found in the carburetor adjustment section:
  - Air Valve Spring Adjustment**, Figure 6C10-33.
  - Choke Coil Lever Adjustment**, Figure 6C10-34.
9. Install the cover and coil assembly in the choke housing:
  - a. Place cam follower on highest step of fast idle cam.
  - b. Install the thermostatic cover and coil assembly, and gasket (if used), in the choke housing, making sure coil tang engages the inside coil pick-up lever.

**NOTICE:** On M4ME models, ground contact for the electric choke is provided by a metal plate located at

the rear of the choke cover assembly. Do not install a choke cover gasket between the electric choke assembly and the choke housing.

- c. A choke cover retainer kit is required to attach the choke cover to the choke housing. Follow instructions contained in kit and install proper retainers and rivets using suitable blind rivet installing tool (Fig. 6C10-30).
  - d. It may be necessary to use an adapter (tube) if the installing tool interferes with the electrical connector tower on the choke cover, (Figure 6C10-30).
  - e. On hot air choke models, torque the choke heat pipe nut to 10 N·m (95 in. lbs.).
10. Install hose on front vacuum break and on tube on float bowl.
  11. If used, position throttle actuating device and/or bracket assembly on float bowl, retaining with two large countersunk screws. Tighten screws securely.
  12. Perform the remaining unit repair adjustments (Figs. 6C10-31 through 6C10-42).
  13. Reinstall carburetor on vehicle with new insulator referring to On-Vehicle Service for installation and idle speed adjustment.

## UNIT REPAIR ADJUSTMENTS

The carburetor adjustments that are part of Unit Repair, in most cases, may be performed on the vehicle.

- Float Adjustment (Fig. 6C10-31)
- Pump Adjustment (Fig. 6C10-32)
- Air Valve Spring Adjustment (Fig. 6C10-33)
- Choke Coil Lever Adjustment (Fig. 6C10-34)
- Choke Valve Angle Gage (Fig. 6C10-35)
- Choke Rod-Fast Idle Cam Adjustment (Fig. 6C10-36)
- Vacuum Break Adjustment Information (Fig. 6C10-37)
- Front (Primary) Vacuum Break Adjustment (Fig. 6C10-38)
- Rear (Auxiliary) Vacuum Break Adjustment (Fig. 6C10-39)
- Air Valve Rod Adjustment - Front (Fig. 6C10-40)
- Air Valve Rod Adjustment - Rear (Fig. 6C10-41)
- Unloader Adjustment (Fig. 6C10-42)
- Secondary Lockout Adjustment (Fig. 6C10-43)

Refer to On-Vehicle Service for additional carburetor adjustment procedures performed on the vehicle.

## SPECIAL TOOLS

Special tools are listed at the end of this section.

## SPECIFICATIONS

Refer to the end of this section for carburetor specifications.

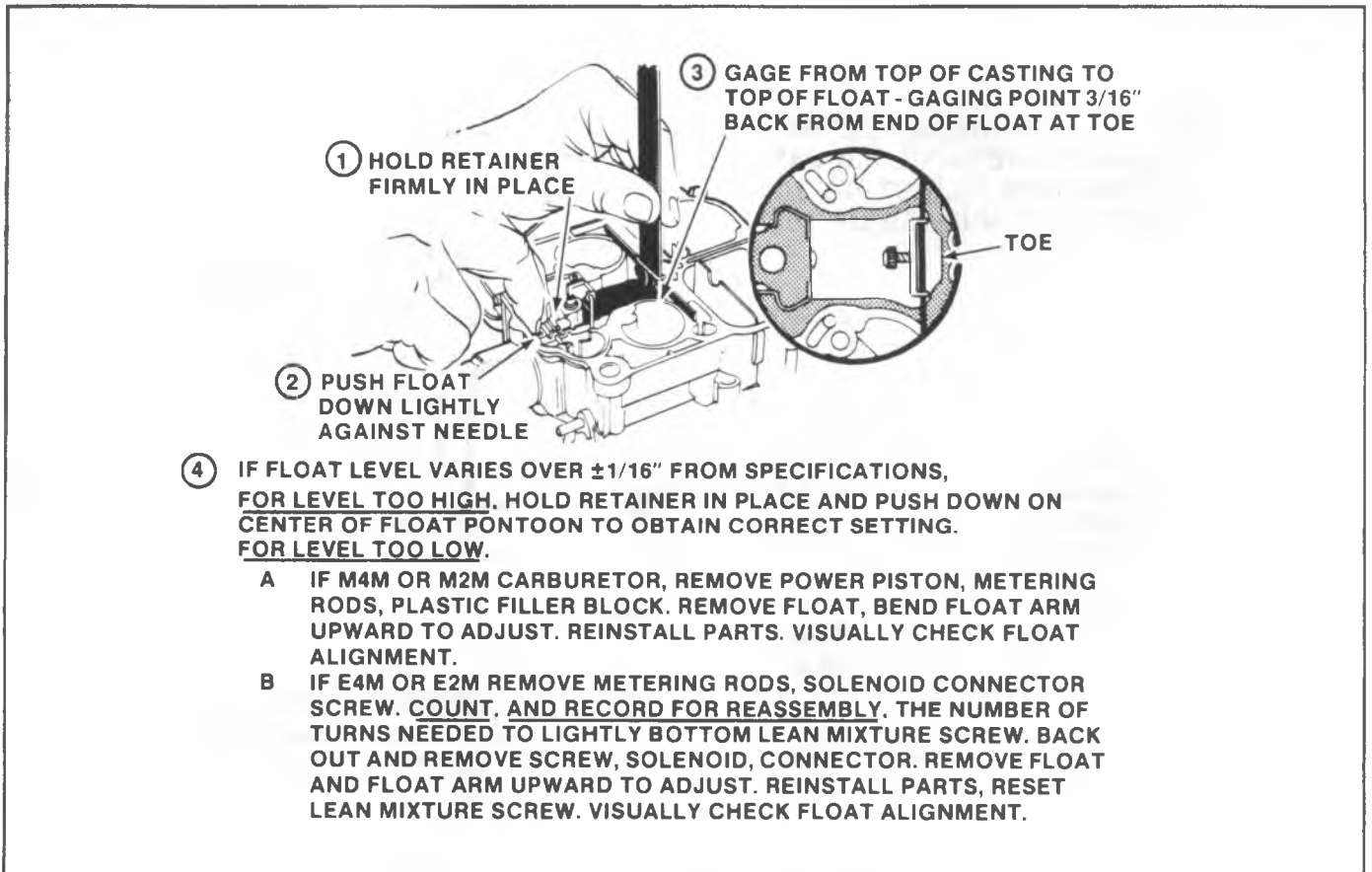

Fig. 6C10-31--Float Adjustment

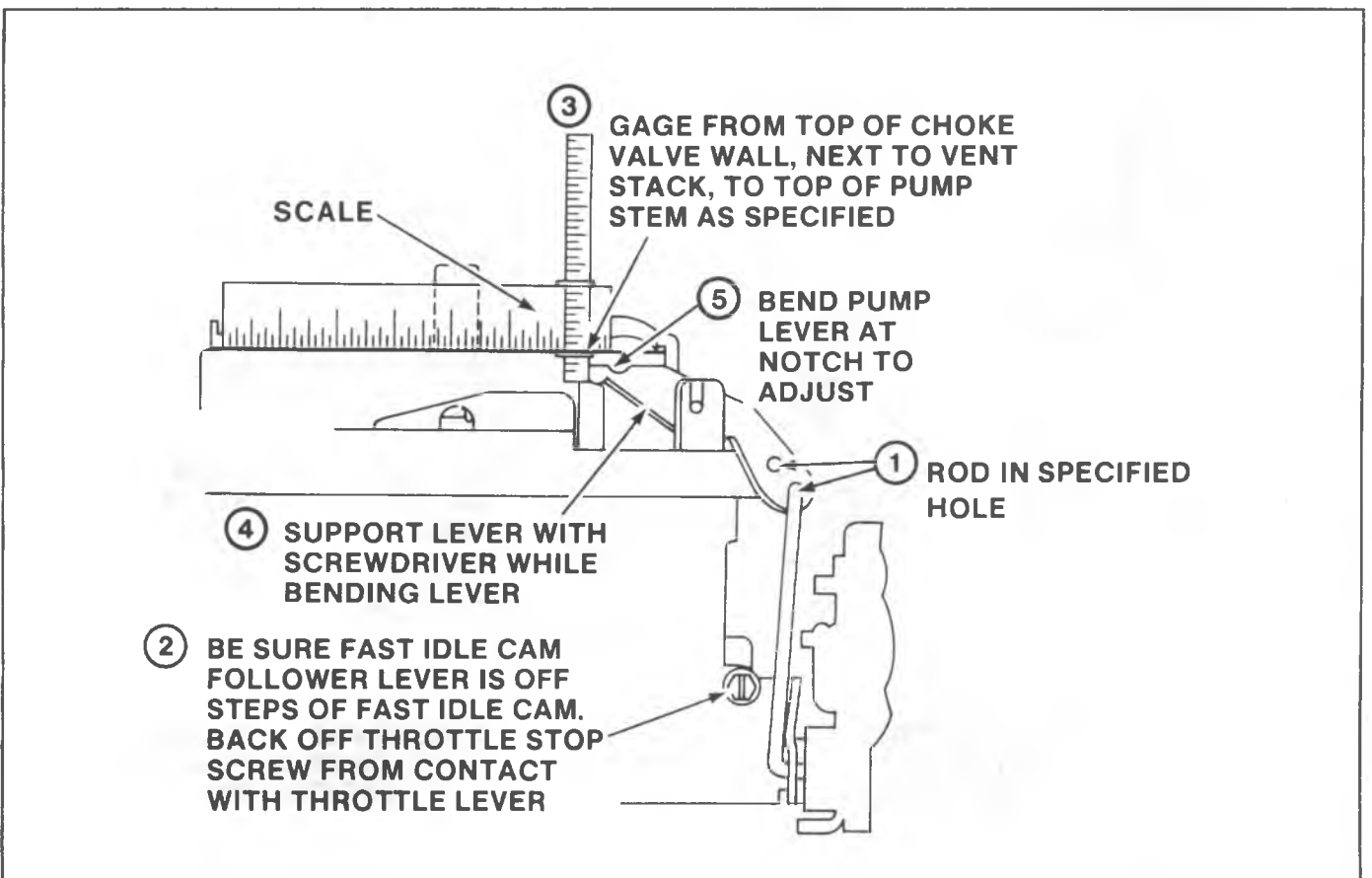

Fig. 6C10-32--Pump Adjustment

- ③ TURN TENSION-ADJUSTING SCREW CLOCKWISE UNTIL AIR VALVE JUST CLOSES. THEN TURN ADJUSTING SCREW CLOCKWISE SPECIFIED NUMBER OF TURNS.

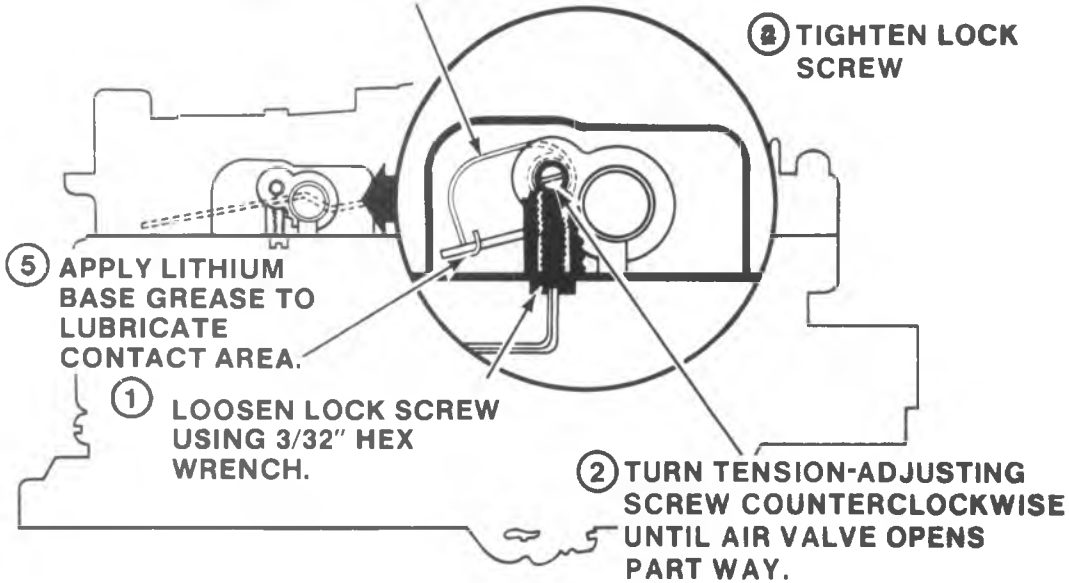

Fig. 6C10-33--Air Valve Spring Adjustment

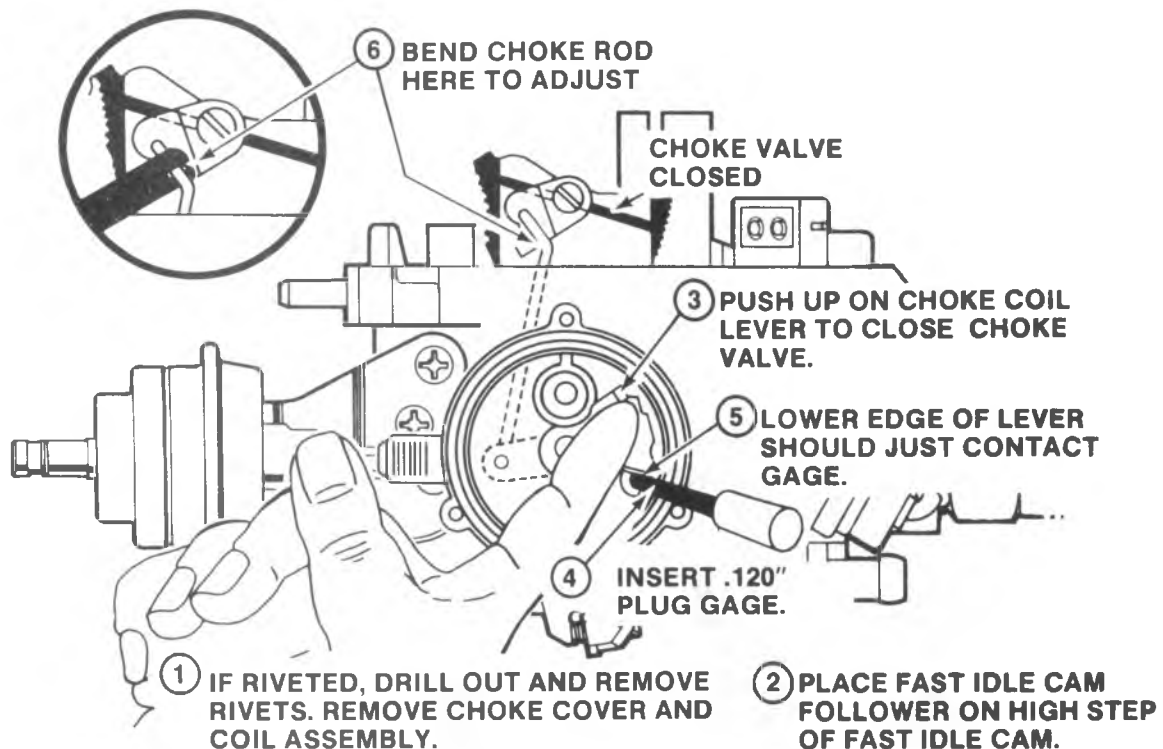

Fig. 6C10-34--Choke Coil Lever Adjustment

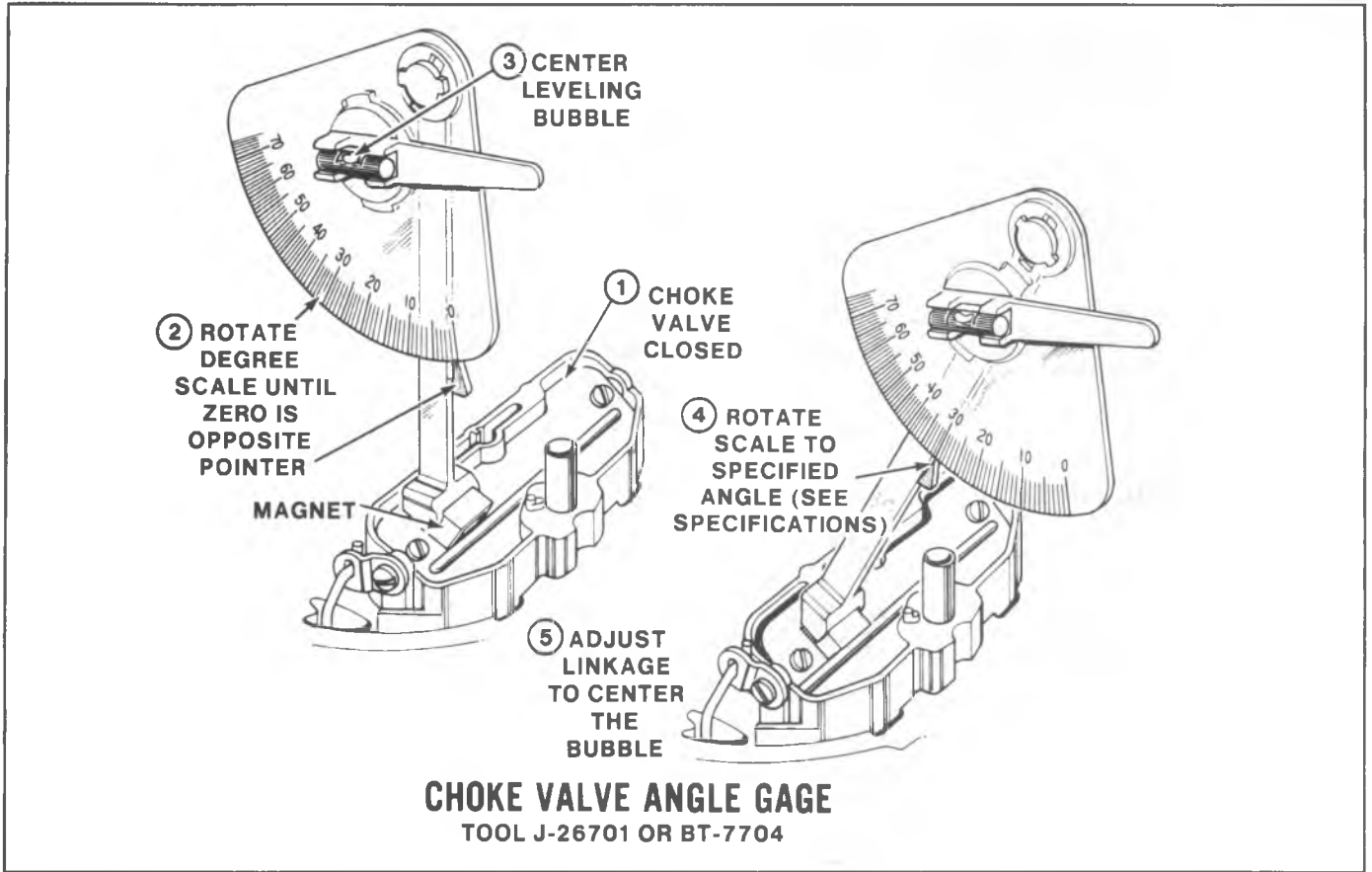

Fig. 6C10-35--Choke Valve Angle Gage

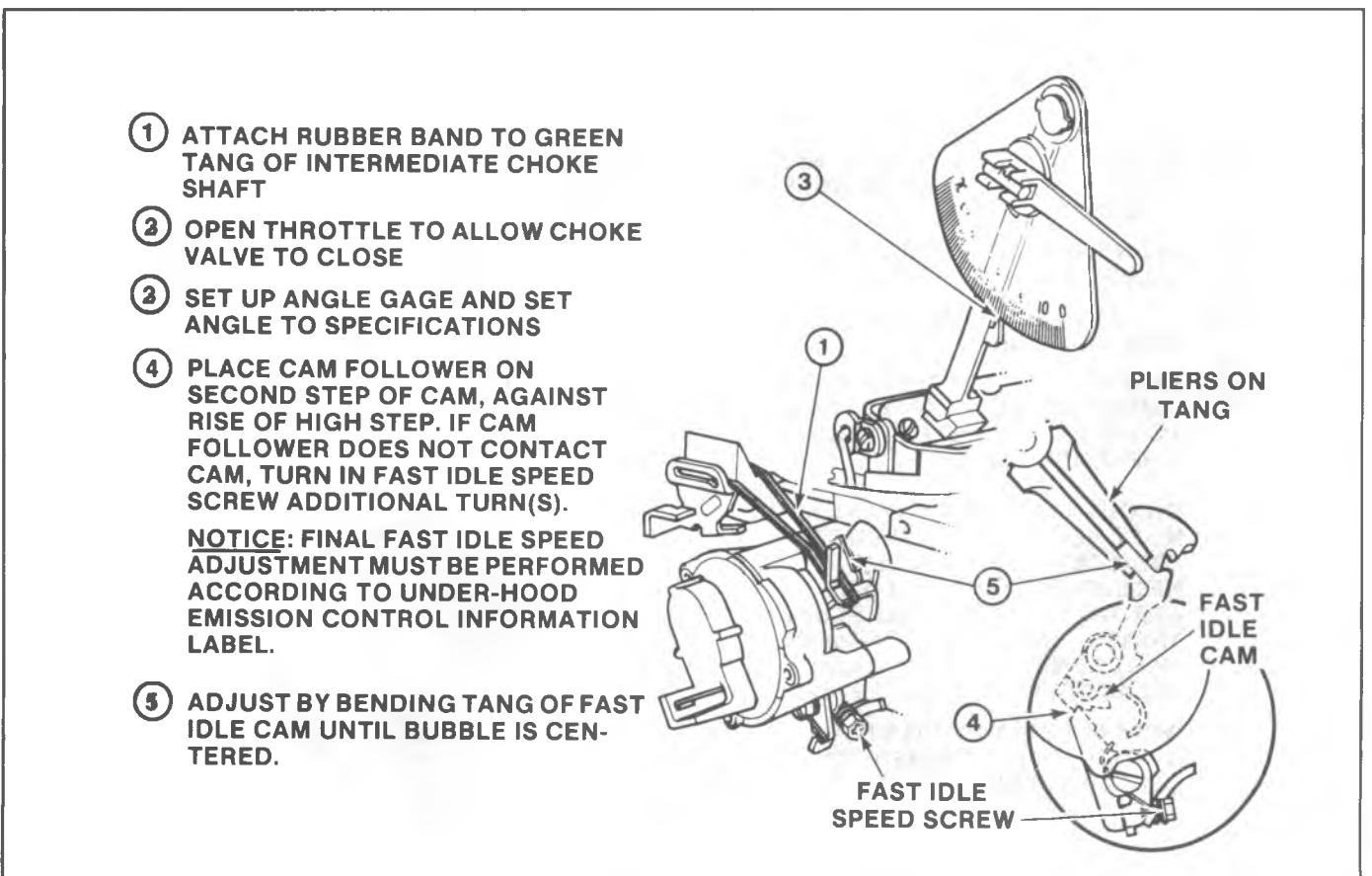
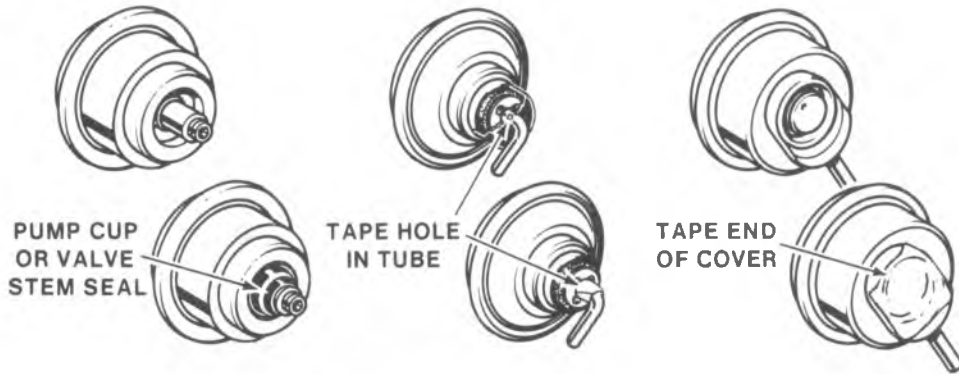

Fig. 6C10-36--Choke Rod-Fast Idle Cam Adjustment

**PLUGGING AIR BLEED HOLES**



**BUCKING SPRINGS**

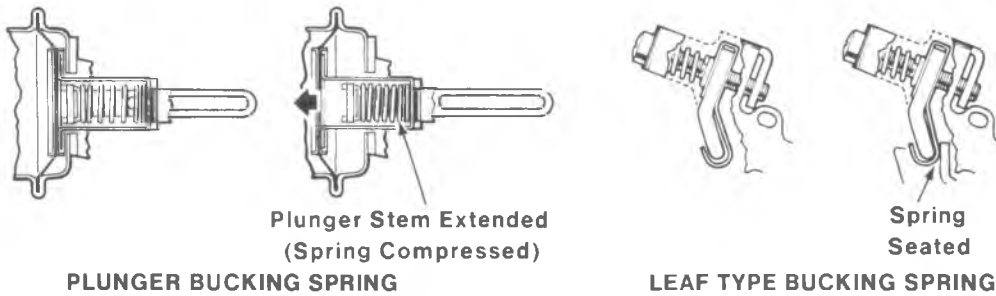

Fig. 6C10-37--Vacuum Break Adjustment Information

- ① ATTACH RUBBER BAND TO GREEN TANG OF INTERMEDIATE CHOKE SHAFT
- ③ OPEN THROTTLE TO ALLOW CHOKE VALVE TO CLOSE
- ③ SET UP ANGLE GAGE AND SET TO SPECIFICATION
- ④ RETRACT VACUUM BREAK PLUNGER USING VACUUM SOURCE, AT LEAST 18" HG. PLUG AIR BLEED HOLES WHERE APPLICABLE

ON QUADRAJETS, AIR VALVE ROD MUST NOT RESTRICT PLUNGER FROM RETRACTING FULLY. IF NECESSARY, BEND ROD (SEE ARROW) TO PERMIT FULL PLUNGER TRAVEL. FINAL ROD CLEARANCE MUST BE SET AFTER VACUUM BREAK SETTING HAS BEEN MADE.

- ⑤ WITH AT LEAST 18" HG STILL APPLIED, ADJUST SCREW TO CENTER BUBBLE

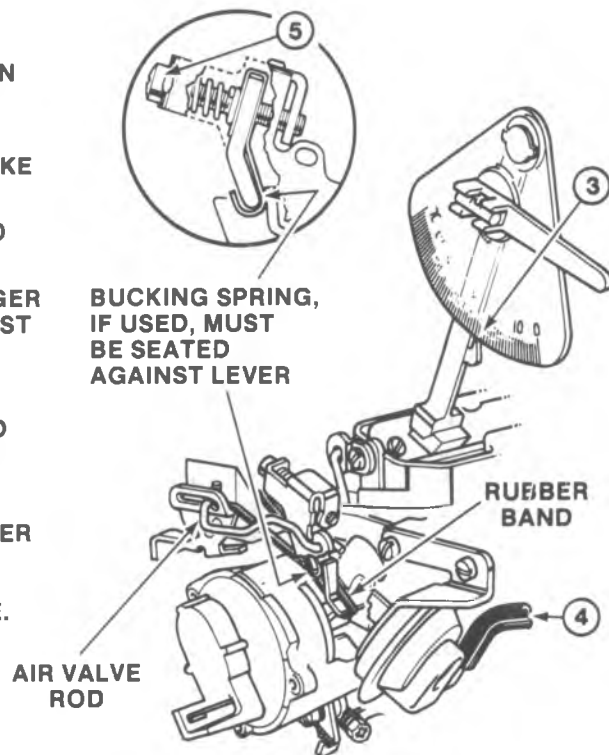

Fig. 6C10-38--Front Vacuum Break Adjustment

- ① ATTACH RUBBER BAND TO GREEN TANG OF INTERMEDIATE CHOKE SHAFT.
- ② OPEN THROTTLE TO ALLOW CHOKE VALVE TO CLOSE.
- ③ SET UP ANGLE GAGE AND SET ANGLE TO SPECIFICATION.
- ④ RETRACT VACUUM BREAK PLUNGER, USING VACUUM SOURCE, AT LEAST 18" HG. PLUG AIR BLEED HOLES WHERE APPLICABLE.
- ④A ON QUADRAJETS, AIR VALVE ROD MUST NOT RESTRICT PLUNGER FROM RETRACTING FULLY. IF NECESSARY, BEND ROD HERE TO PERMIT FULL PLUNGER TRAVEL. WHERE APPLICABLE, PLUNGER STEM MUST BE EXTENDED FULLY TO COMPRESS PLUNGER BUCKING SPRING.

- ⑤ TO CENTER BUBBLE, EITHER:
  - A. ADJUST WITH 1/8" HEX WRENCH (VACUUM STILL APPLIED)
  - OR-
  - B. SUPPORT AT "S" AND BEND VACUUM BREAK ROD (VACUUM STILL APPLIED)

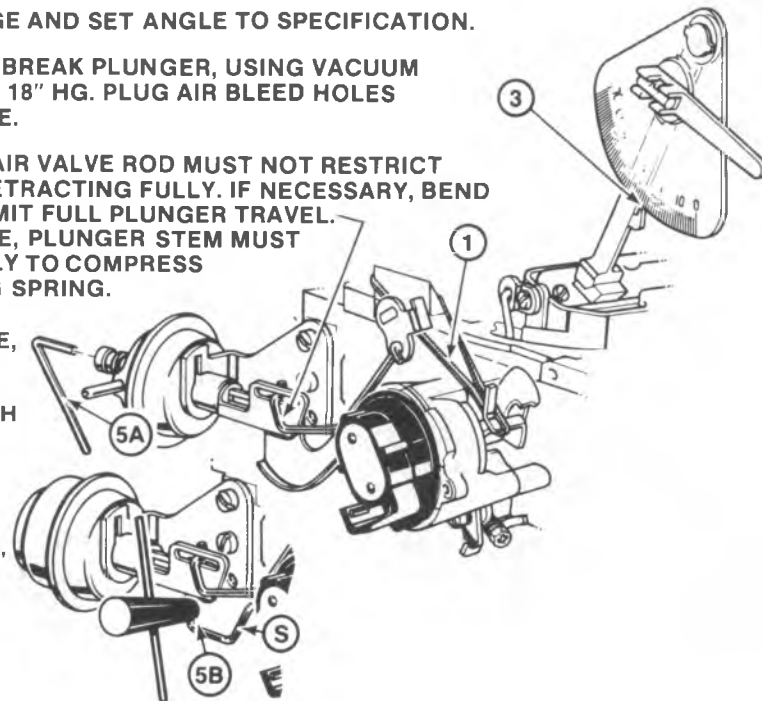

Fig. 6C10-39--Rear Vacuum Break Adjustment

- ③ .025" PLUG GAGE BETWEEN ROD AND END OF SLOT
- ② AIR VALVE CLOSED COMPLETELY
- ④ BEND ROD HERE TO ADJUST GAGE CLEARANCE TO .025", WITH VACUUM AT LEAST 18" HG.
- ① USE VACUUM SOURCE, AT LEAST 18" HG, TO SEAT VACUUM BREAK PLUNGER. PLUG AIR BLEED HOLES WHERE APPLICABLE.

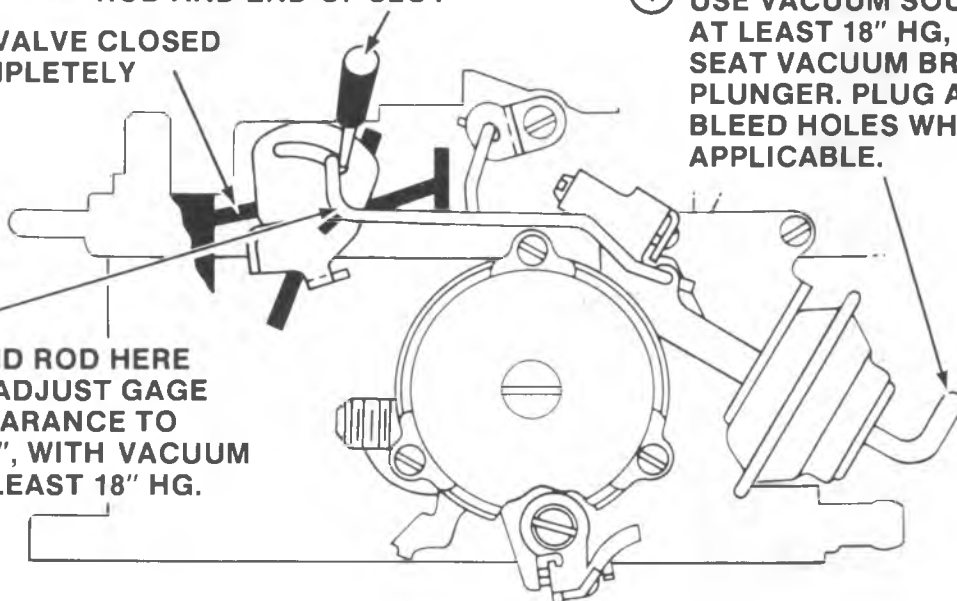

Fig. 6C10-40--Air Valve Rod Adjustment - Front



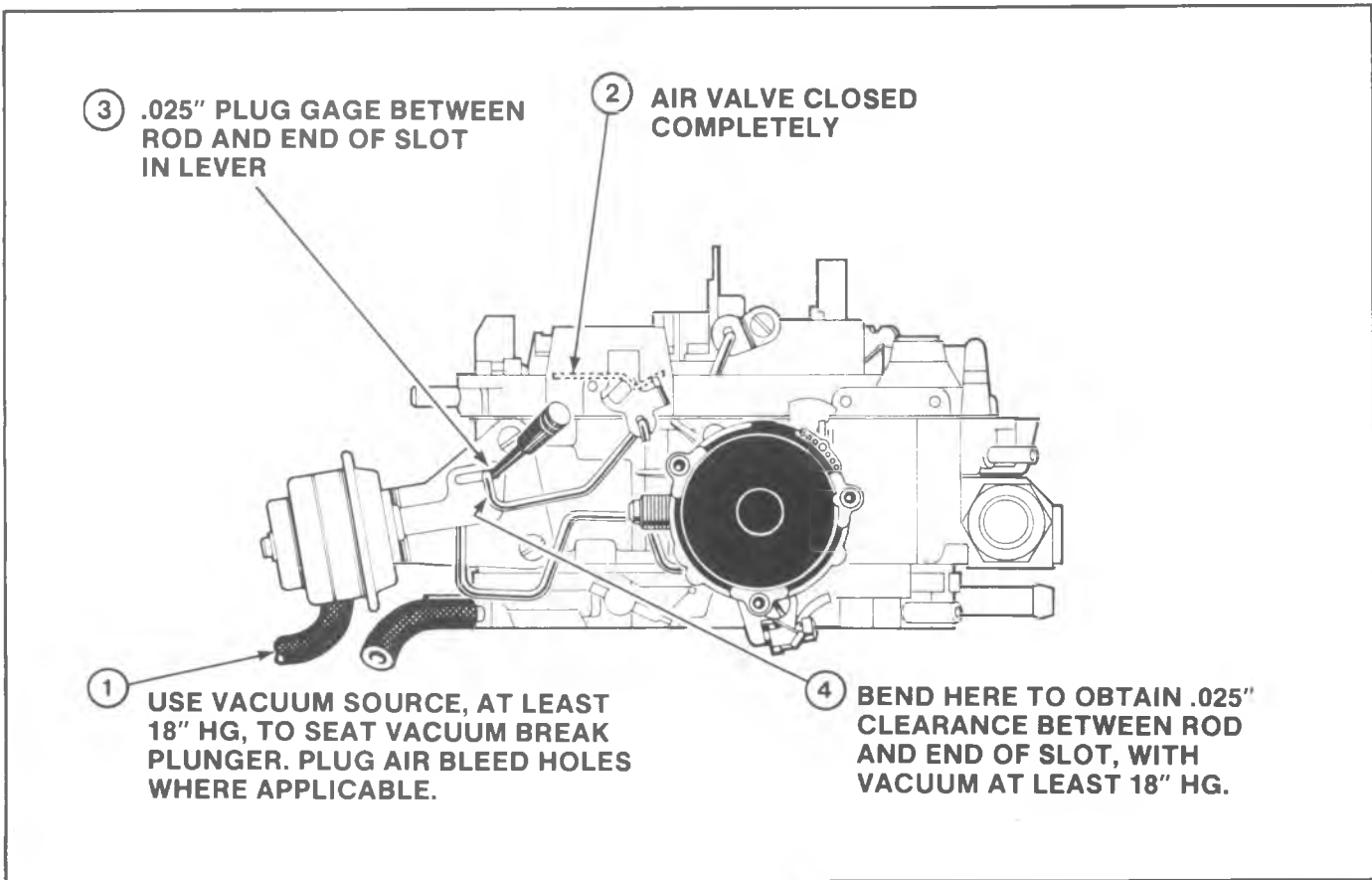

Fig. 6C10-41--Air Valve Rod Adjustment - Rear

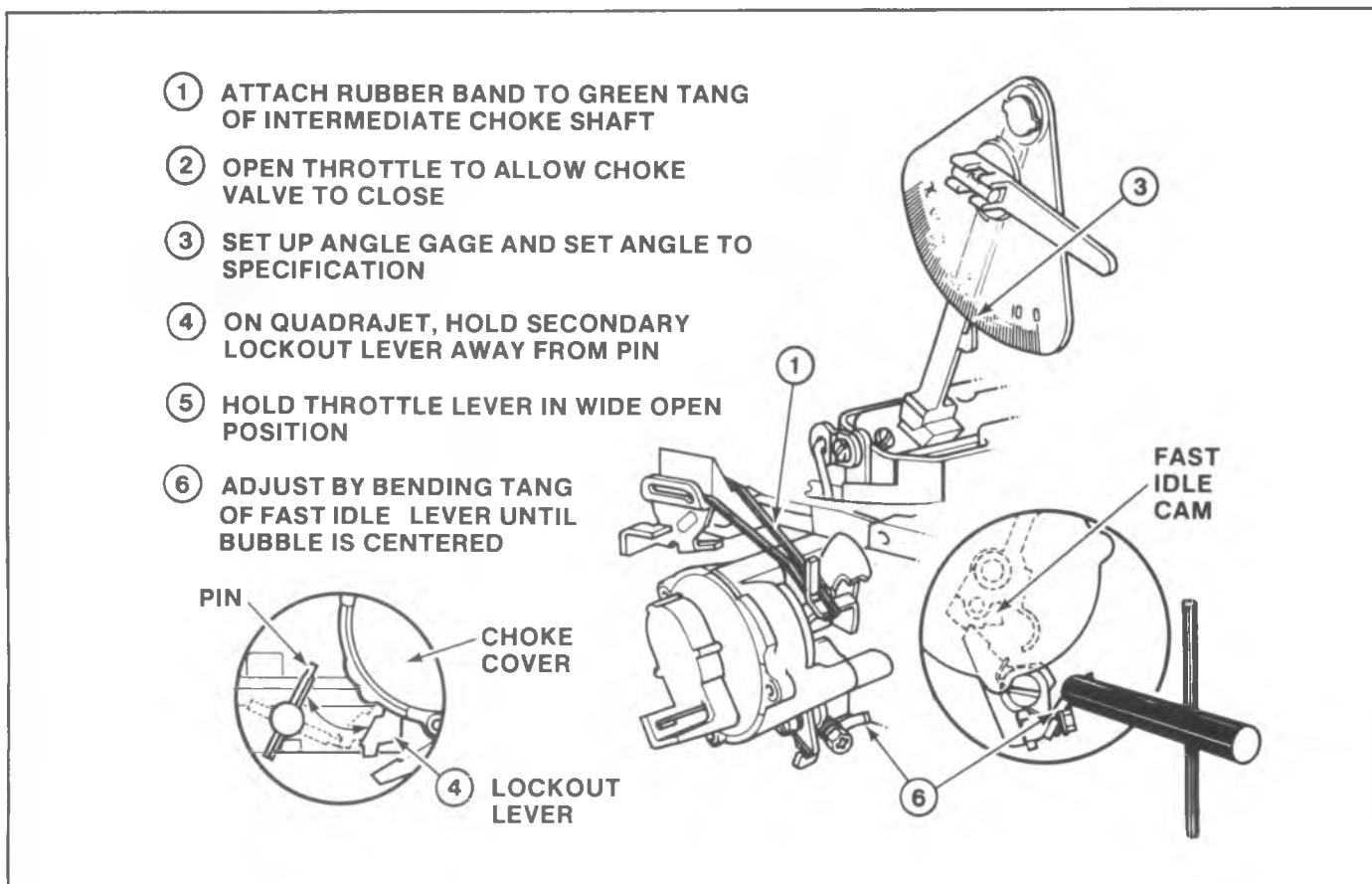

Fig. 6C10-42--Unloader Adjustment

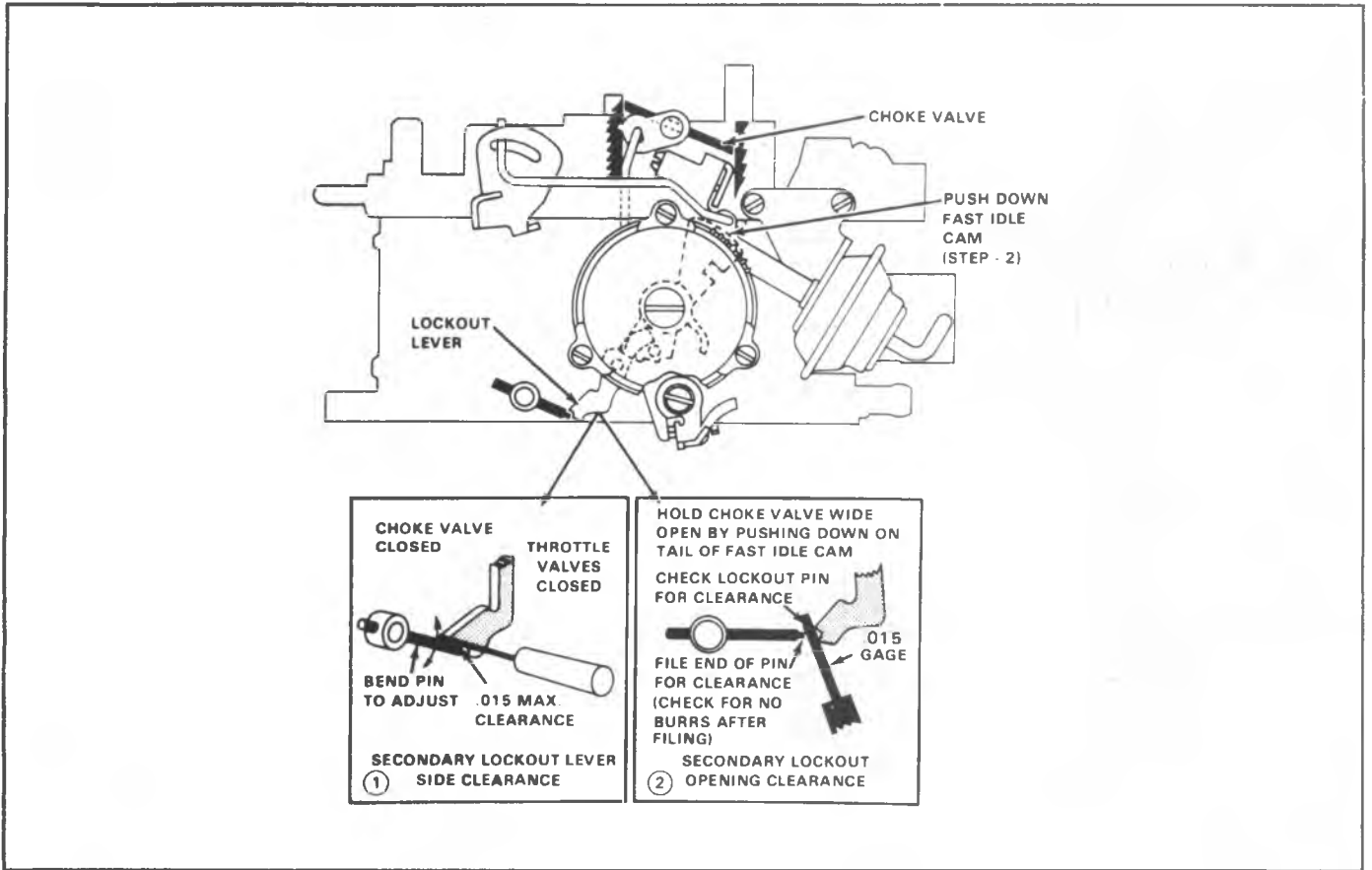

Fig. 6C10-43--Secondary Lockout Adjustment

## SPECIAL TOOLS

|  |                                |
|--|--------------------------------|
| Digital Multimeter.....                          | J-29125-A/BT-345               |
| Carburetor Gage Set.....                         | J-9789-C/BT-3005-A             |
| Float Level T - Scale.....                       | J-9789-90/BT-8037              |
| Bending Tool.....                                | J-9789-111/BT-3007             |
| Carburetor Stand.....                            | J-9789-118/BT-30-15            |
| Carburetor Float Level Gage.....                 | J-9789-130/BT-7720             |
| Carburetor Choke Angle Gage.....                 | J-26701-A/BT-7704              |
| Choke Lever Installing Tool.....                 | J-23417/BT-6911                |
| Idle Mixture Socket.....                         | J-29030-B/BT-7610B             |
| Hand Vacuum Device.....                          | J-23738/BT-7517                |
| Mixture Control Adjustment Set.....              | J-28696-B/BT-7928              |
| Rich/Lean Mixture Screw Adjust.....              | J-28696-10/BT-2967 and BT-7928 |
| Pump Lever Pin Punch.....                        | J-25322/BT-7523                |
| Needle Valve Seat Remover Installer.....         | J-22769/BT-3006M               |
| Rich Mixture Screw Remover Installer.....        | J-28696-4/BT-7967 and BT-7928  |
| Propane Enrichment Device.....                   | J-26911/BT-7816                |
| Fuel Inlet Nut Wrench.....                       | J-23443                        |
| Remote Control Carburetor Adjustment Wrench..... | J-22646-02/BT-3555             |

## MODEL M4MC/M4ME CARBURETOR ADJUSTMENT – 5.7L ENGINE

| CARBURETOR PART NO. | FLOAT LEVEL<br>mm (Inches) | PUMP ROD LOCATION | PUMP ROD SETTING<br>mm (Inches) | FAST IDLE CAM (CHOKE ROD) | AIR VALVE ROD<br>mm (Inches) | VACUUM BREAK FRONT | VACUUM BREAK REAR | AIR VALVE SPRING (Turns) | UNLOAD-ER | PROPANE ENRICHMENT SPEED |
|---------------------|----------------------------|-------------------|---------------------------------|---------------------------|------------------------------|--------------------|-------------------|--------------------------|-----------|--------------------------|
| 17080201            | 12.0 (15/32)               | INNER             | 7.0 (9/32)                      | 46°                       | 0.6 (.025)                   | –                  | 23°               | 7/8                      | 42°       |                          |
| 17080205            | 12.0 (15/32)               | INNER             | 7.0 (9/32)                      | 46°                       | 0.6 (.025)                   | –                  | 23°               | 7/8                      | 42°       |                          |
| 17080206            | 12.0 (15/32)               | INNER             | 7.0 (9/32)                      | 46°                       | 0.6 (.025)                   | –                  | 23°               | 7/8                      | 42°       |                          |
| 17080213            | 9.5 (3/8)                  | INNER             | 7.0 (9/32)                      | 37°                       | 0.6 (.025)                   | 23°                | 30°               | 1                        | 40°       |                          |
| 17080290            | 12.0 (15/32)               | INNER             | 7.0 (9/32)                      | 46°                       | 0.6 (.025)                   | –                  | 26°               | 7/8                      | 42°       |                          |
| 17080291            | 12.0 (15/32)               | INNER             | 7.0 (9/32)                      | 46°                       | 0.6 (.025)                   | –                  | 26°               | 7/8                      | 42°       |                          |
| 17080292            | 12.0 (15/32)               | INNER             | 7.0 (9/32)                      | 46°                       | 0.6 (.025)                   | –                  | 26°               | 7/8                      | 42°       |                          |
| 17080298            | 9.5 (3/8)                  | INNER             | 7.0 (9/32)                      | 37°                       | 0.6 (.025)                   | 23°                | 30°               | 1                        | 40°       |                          |
| 17080507            | 9.5 (3/8)                  | INNER             | 7.0 (9/32)                      | 37°                       | 0.6 (.025)                   | 23°                | 30°               | 1                        | 40°       |                          |
| 17080513            | 9.5 (3/8)                  | INNER             | 7.0 (9/32)                      | 37°                       | 0.6 (.025)                   | 23°                | 30°               | 1                        | 40°       |                          |
| 17082213            | 7.0 (9/32)                 | INNER             | 7.0 (9/32)                      | 37°                       | 0.6 (.025)                   | 23°                | 30°               | 1                        | 40°       |                          |
| 17083234            | 10.0 (13/32)               | INNER             | 7.0 (9/32)                      | 46°                       | 0.6 (.025)                   | –                  | 26°               | 7/8                      | 39°       | 20                       |
| 17083235            | 10.0 (13/32)               | INNER             | 7.0 (9/32)                      | 46°                       | 0.6 (.025)                   | –                  | 26°               | 7/8                      | 39°       | 100                      |
| 17083290            | 10.0 (13/32)               | INNER             | 7.0 (9/32)                      | 46°                       | 0.6 (.025)                   | –                  | 24°               | 7/8                      | 39°       | 40                       |
| 17083291            | 10.0 (13/32)               | INNER             | 7.0 (9/32)                      | 46°                       | 0.6 (.025)                   | –                  | 24°               | 7/8                      | 39°       | 100                      |
| 17083292            | 10.0 (13/32)               | INNER             | 7.0 (9/32)                      | 46°                       | 0.6 (.025)                   | –                  | 24°               | 7/8                      | 39°       | 40                       |
| 17083293            | 10.0 (13/32)               | INNER             | 7.0 (9/32)                      | 46°                       | 0.6 (.025)                   | –                  | 24°               | 7/8                      | 39°       | 100                      |
| 17083298            | 9.5 (3/8)                  | INNER             | 7.0 (9/32)                      | 37°                       | 0.6 (.025)                   | 23°                | 30°               | 1                        | 40°       |                          |
| 17083507            | 9.5 (3/8)                  | INNER             | 7.0 (9/32)                      | 37°                       | 0.6 (.025)                   | 23°                | 30°               | 1                        | 40°       |                          |

## MODEL M4MC/M4ME CARBURETOR ADJUSTMENTS – 7.4L ENGINE

| CARBURETOR PART NO. | FLOAT LEVEL<br>mm (Inches) | PUMP ROD LOCATION | PUMP ROD SETTING<br>mm (Inches) | FAST IDLE CAM (CHOKE ROD) | AIR VALVE ROD<br>mm (Inches) | VACUUM BREAK FRONT | VACUUM BREAK REAR | AIR VALVE SPRING (Turns) | UN-LOADER | PROPANE ENRICHMENT SPEED |
|---------------------|----------------------------|-------------------|---------------------------------|---------------------------|------------------------------|--------------------|-------------------|--------------------------|-----------|--------------------------|
| 17080212            | 9.5 (3/8)                  | INNER             | 7.0 (9/32)                      | 46°                       | 0.6 (.025)                   | 24°                | 30°               | 3/4                      | 40°       |                          |
| 17080512            | 9.5 (3/8)                  | INNER             | 7.0 (9/32)                      | 46°                       | 0.6 (.025)                   | 24°                | 30°               | 3/4                      | 40°       |                          |

## MODEL M4MC/M4ME CARBURETOR ADJUSTMENTS – 5.0L ENGINE

| CARBURETOR PART NO. | FLOAT LEVEL<br>mm (Inches) | PUMP ROD LOCATION | PUMP ROD SETTING<br>mm (Inches) | FAST IDLE CAM (CHOKE ROD) | AIR VALVE ROD<br>mm (Inches) | VACUUM BREAK FRONT | VACUUM BREAK REAR | AIR VALVE SPRING (Turns) | UN-LOADER | PROPANE ENRICHMENT SPEED |
|---------------------|----------------------------|-------------------|---------------------------------|---------------------------|------------------------------|--------------------|-------------------|--------------------------|-----------|--------------------------|
| 17083220            | 10.0 (13/32)               | INNER             | 7.0 (9/32)                      | 46°                       | 0.6 (.025)                   | –                  | 24°               | 7/8                      | 39°       | 150                      |
| 17083221            | 10.0 (13/32)               | INNER             | 7.0 (9/32)                      | 46°                       | 0.6 (.025)                   | –                  | 24°               | 7/8                      | 39°       | 150                      |
| 17083222            | 10.0 (13/32)               | INNER             | 7.0 (9/32)                      | 46°                       | 0.6 (.025)                   | –                  | 24°               | 7/8                      | 39°       | 50                       |
| 17083223            | 10.0 (13/32)               | INNER             | 7.0 (9/32)                      | 46°                       | 0.6 (.025)                   | –                  | 24°               | 7/8                      | 39°       | 150                      |
| 17083224            | 10.0 (13/32)               | INNER             | 7.0 (9/32)                      | 46°                       | 0.6 (.025)                   | –                  | 24°               | 7/8                      | 39°       | 50                       |
| 17083225            | 10.0 (13/32)               | INNER             | 7.0 (9/32)                      | 46°                       | 0.6 (.025)                   | –                  | 24°               | 7/8                      | 39°       | 150                      |
| 17083226            | 10.0 (13/32)               | INNER             | 7.0 (9/32)                      | 46°                       | 0.6 (.025)                   | –                  | 24°               | 7/8                      | 39°       | 50                       |
| 17083227            | 10.0 (13/32)               | INNER             | 7.0 (9/32)                      | 46°                       | 0.6 (.025)                   | –                  | 24°               | 7/8                      | 39°       | 50                       |
| 17083230            | 10.0 (13/32)               | INNER             | 7.0 (9/32)                      | 46°                       | 0.6 (.025)                   | –                  | 26°               | 7/8                      | 39°       | 20                       |
| 17083231            | 10.0 (13/32)               | INNER             | 7.0 (9/32)                      | 46°                       | 0.6 (.025)                   | –                  | 26°               | 7/8                      | 39°       | 100                      |

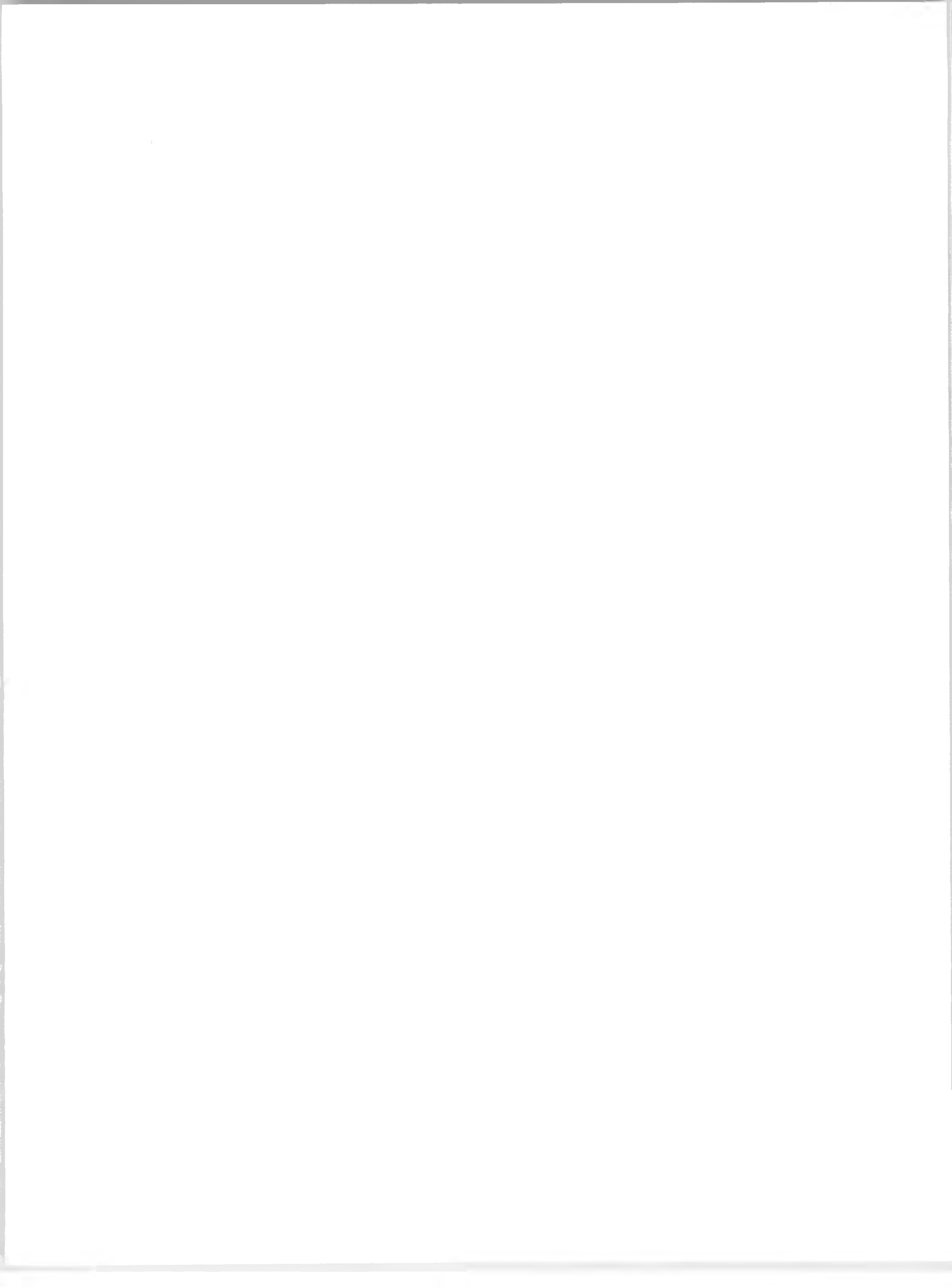

# DIESEL FUEL INJECTION

## CONTENTS

|   |   |  |    |
|---|---|--|----|
| General Description                     |   | Fuel Line Heater .....                   | 7  |
| Water In Fuel .....                     | 1 | Injection Pump .....                     | 8  |
| Primary Fuel Filter .....               | 1 | Checking Or Adjusting Timing .....       | 9  |
| Secondary Fuel Filter .....             | 2 | Injection Nozzle .....                   | 10 |
| Idle Speed Setting .....                | 3 | Injection Pump On Vehicle Service .....  | 11 |
| T.P.S. Adjustment .....                 | 4 | Injection Pump Off Vehicle Service ..... | 16 |
| Vacuum Regulator Valve Adjustment ..... | 4 | Drive Shaft Seal Replacement .....       | 17 |
| Housing Pressure Cold Advance .....     | 4 | Pressure Test .....                      | 17 |
| Injection Pump Fuel Lines .....         | 6 |  |    |

## GENERAL DESCRIPTION

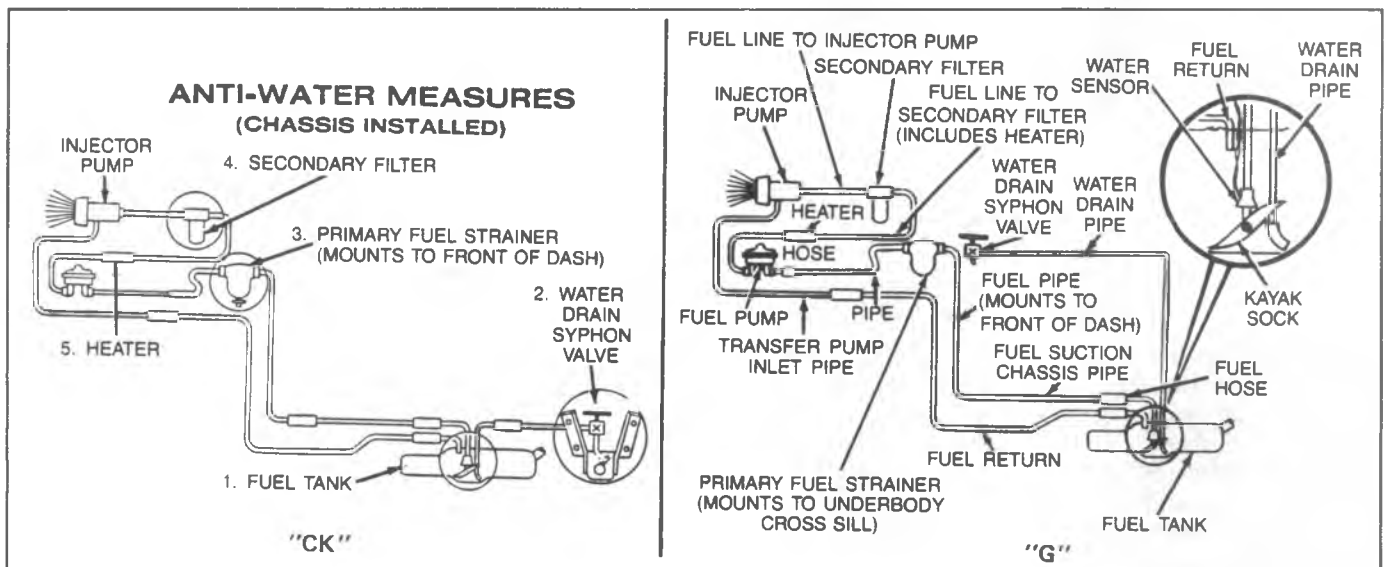

Fig. 6C6-1--Water In Fuel

### FUEL SYSTEM

The 6.2 liter diesel engine fuel system is composed of:

- Fuel tank with water sensor and screen filter.
- Primary Fuel Filter.
- Mechanical fuel pump.
- Secondary Fuel filter.
- Fuel line heater.
- Injection distributor pump.
- High pressure lines.
- Fuel injection nozzles.

Fuel is pulled from the fuel tank by the Mechanical pump which is located on the right side of the engine. It is driven by an eccentric lobe on the camshaft through a push rod. Fuel is pulled through the primary filter, by the Mechanical pump. Fuel is then pumped through the secondary filter mounted on the inlet manifold, manifold. Both filters remove foreign material which could damage the injection pump or clog the injector nozzle. From the filter, the fuel is pumped to the injection pump.

The 6.2 liter injection pump is mounted on top of the engine under the intake manifold. It is gear driven by 2 gears -- one attached to the front end of the camshaft which drives the second gear that is attached to the end of the injection pump shaft. These 2 gears are the same size and have the same number of teeth; thus, the injection pump shaft turns at the same rate as the camshaft and one-half the speed of the crankshaft. The pump will turn in the opposite direction to that of the camshaft and crankshaft.

The injection pump is a high pressure rotary type pump that directs a metered pressurized fuel through the high pressure tubes to the eight injector nozzles. The eight high pressure lines are all the same length although their shape may be different. This prevents any difference in timing, cylinder to cylinder.

### WATER IN FUEL (FIG. 6C6-1)

The diesel engine has a water in fuel warning system allowing the user to guard against water in fuel, which is very critical in diesel engines.

The fuel tank is equipped with a filter (Fig. 6C6-2)

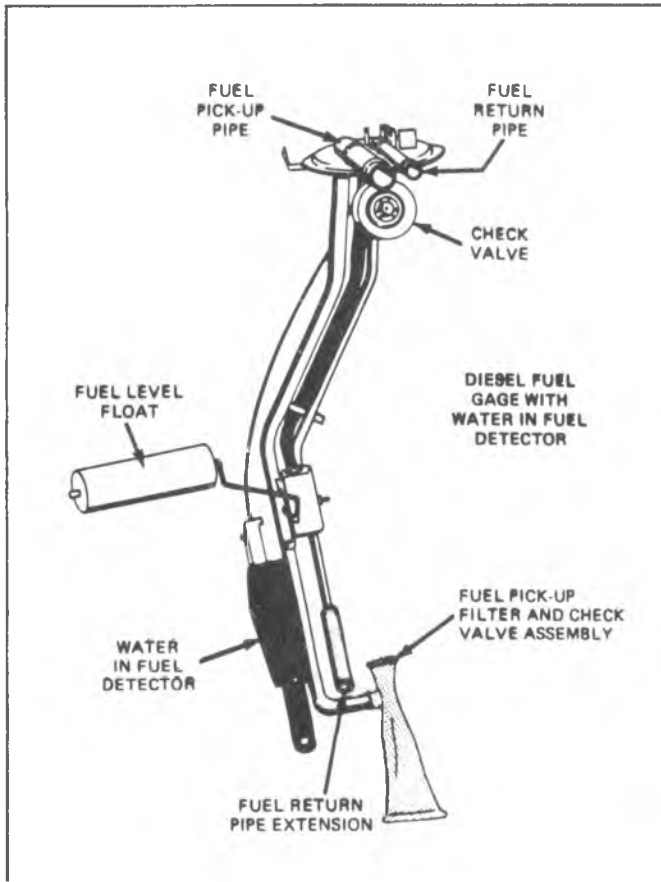

Fig. 6C6-2--Water In Fuel Tank Unit

which screens out the water and lets it lay in the bottom of the tank below the fuel pickup. When the water level reaches a point where it could be drawn into the system, a warning light flashes in the cab. A siphoning system starting at the tank and going to the rear spring hanger on some models and at the midway point of the right frame rail on other models permits the user to attach a hose at the shut-off and siphon out the water.

A primary filter is located on the front of dash on CK models. The primary filter on the G Van is mounted to the

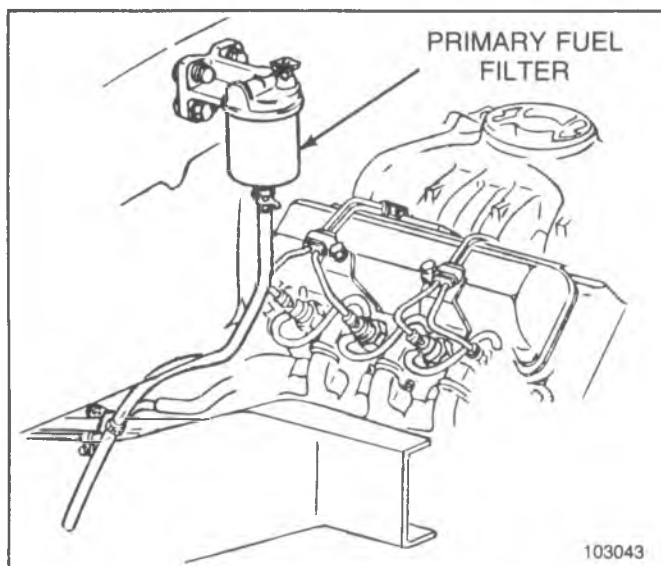

Fig. 6C6-3--Primary Filter-CK Truck

vehicle chassis right hand underbody cross sill forward of the fuel tank. The primary filter also has water draining provisions.

A secondary in line fuel filter is the final filter before fuel enters the injection pump.

### PRIMARY FUEL FILTER-WATER DRAIN (Fig. 6C6-2)

If it should become necessary to drain water from the fuel tank, also check the primary fuel filter for water. This can be done as follows:

1. Open the petcock on the top of the primary filter housing.
2. Place a drain pan below the filter and open the petcock on the bottom of the drain assembly. (A length of hose is attached to the petcock to direct drained fluid below the frame.)
3. When all water is drained from the filter, close the petcock lightly.

**NOTICE:** If filter is completely drained, remove filter and refill with clean diesel fuel to prevent engine stalling.

4. Close upper petcock tightly.
5. Start the engine and let it run briefly. The engine may run roughly for a short time until the air is purged from the system.
6. If engine continues to run roughly, check that both petcocks at the primary filter are closed tightly.

### SECONDARY FUEL FILTER

#### CK Truck

##### Removal

1. Remove air cleaner.
2. Remove fuel filter lines from adapter.
3. Remove fuel filter adapter.
4. Remove fuel filter.

##### Installation

1. Install filter to adapter, tighten 2/3 turn after contacting gasket.

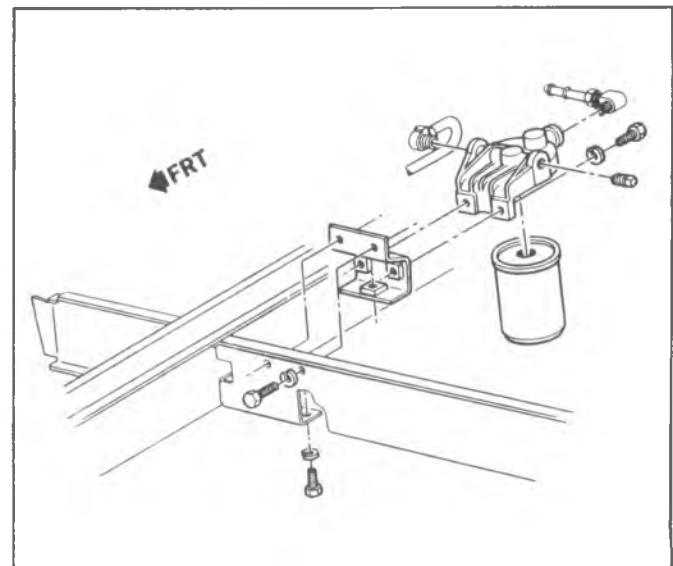

Fig. 6C6-4--Primary Filter G Van

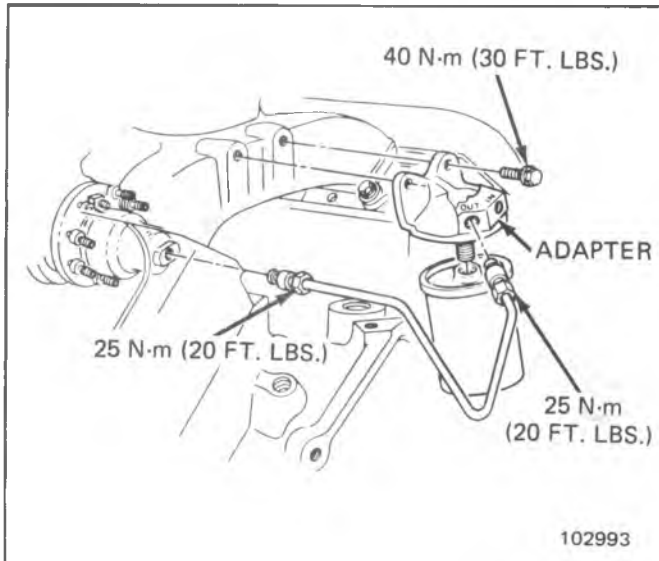

Fig. 6C6-5--Secondary Fuel Filter CK Truck

2. Install adapter to intake manifold.
3. Install the fuel filter inlet line only.  
Any time the secondary filter is removed or replaced, air must be purged from the filter to prevent engine stalling or excessive cranking time to restart.
4. With the secondary fuel line disconnected, disconnect the pink electrical wire from the fuel injection pump to prevent the engine from starting.
5. Place a towel or cloth under the filter outlet.
6. Crank the engine (for 10 seconds max) until fuel is observed at the outlet port.
7. If fuel is not observed after 10 seconds, wait 15 seconds, repeat Step 6.
8. When fuel is observed at the outlet port, install the outlet line.
9. Reconnect pink wire at injection pump and reinstall air cleaner.
10. Start engine and allow to idle for several minutes to purge remaining air.

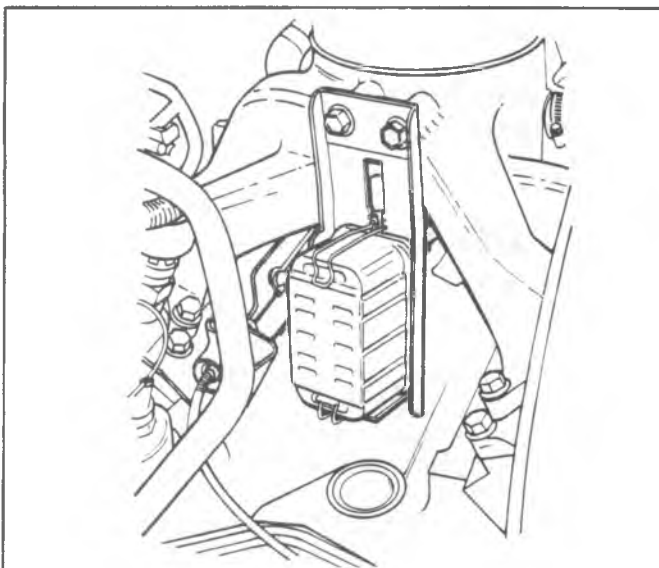

Fig. 6C6-6--Secondary Fuel Filter G and P Models

11. Check all fittings and filter for leakage, remove towel or cloth.
12. Install air cleaner.

### G and P Models

#### Removal

1. Engine must be turned off.
2. Remove engine cover.
3. Remove air cleaner.
4. Place a cloth or towel under filter.
5. Unstrap lower bail on filter to relieve fuel pressure in the filter.
6. Unstrap the upper bail and remove filter.

#### Installation

1. Insure that both filter mounting plate fittings are free of dirt.
2. Install new filter, snap on the upper bail clamp only.  
Any time the secondary filter is removed or replaced, air must be purged from the filter to prevent engine stalling or excessive cranking time to restart.
3. Disconnect the pink electrical wire from the injection pump to prevent engine from starting.
4. Crank engine (for 10 seconds max.) until fuel is observed at the lower filter fitting.
5. If fuel is not observed after 10 seconds, wait 15 seconds, repeat Step 4.
6. When fuel is observed at the lower fitting, connect the lower bail clamp.
7. Reconnect the pink wire on the injection pump and install the air cleaner.
8. Start engine and allow to idle for several minutes to purge remaining air. Check for fuel leaks.
9. Remove towel or cloth and reinstall engine cover.

### IDLE SPEED SETTING PROCEDURE (FIGS. 6C6-7 and 6C6-8)

1. All idle speeds are to be set within 25 RPM of specified value.

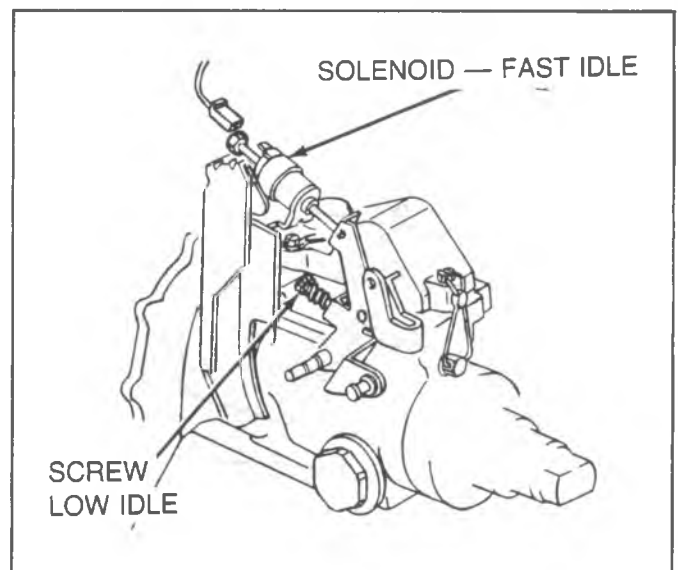

Fig. 6C6-7--Idle Speed Adjustments



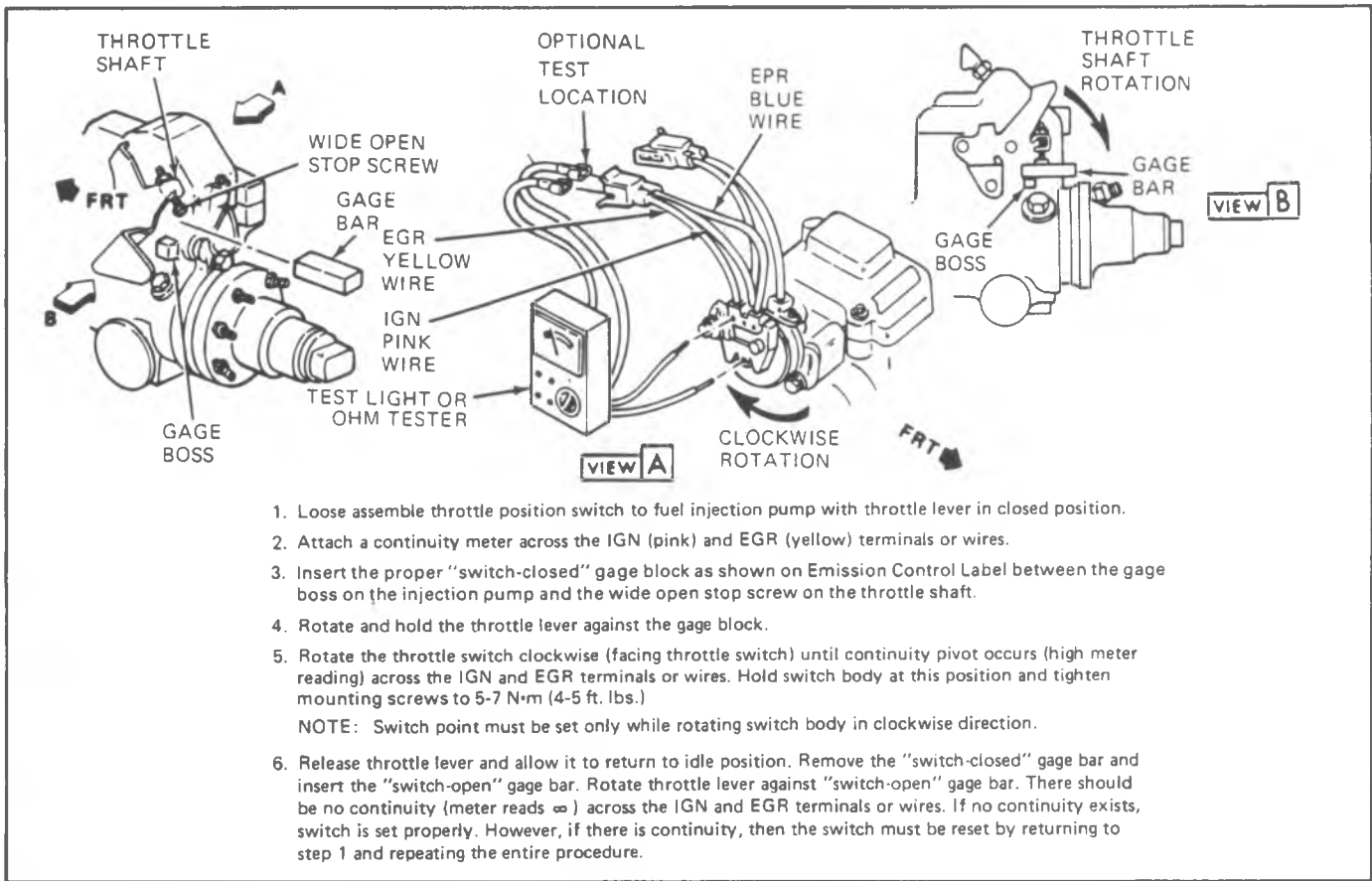

Fig. 6C6-9--T.P.S. Adjustment LH6 Engine

2. Set parking brake and block drive wheels.
3. Engine must be at normal operating temperature. Air cleaner should be on and all accessories should be turned off.
4. Install, tool J-26925, diesel tachometer or equivalent per manufacturers instructions.
5. Adjust low idle speed screw on fuel injection pump to an engine speed of 650 RPM in neutral or park for automatic transmission and for manual transmissions.
6. Adjust fast idle speed as follows:

- a. Remove connector from fast idle solenoid. Use an insulated jumper wire from battery positive terminal to solenoid terminal to energize solenoid.
  - b. Open throttle momentarily to ensure that the fast idle solenoid plunger is energized and fully extended.
  - c. Adjust the extended plunger by turning the hex head to an engine fast idle speed of 800 RPM in neutral.
  - d. Remove jumper wire and reinstall connector to fast idle solenoid.
7. Remove tachometer.

**THROTTLE POSITION SWITCH AND VACUUM REGULATOR VALVE ADJUSTMENT (FIGS. 6C6-9,10,11)**

**HOUSING PRESSURE COLD ADVANCE**

The HPCA feature is designed to advance the injection timing about 4° during cold operation. This circuit is actuated by a temperature switch on the right rear head bolt. The switch is calibrated to open the circuit at 115°F. Below the switching point, housing pressure is decreased from 10 psi to zero which advances the timing 4°. Above 115°F, the switch opens de-energizing the solenoid and the housing pressure is return to 10 psi. The fast idle solenoid is energized by the same switch. The switch again closes when the temperature falls below 85°F.

Purpose:

1. Emission Control device.

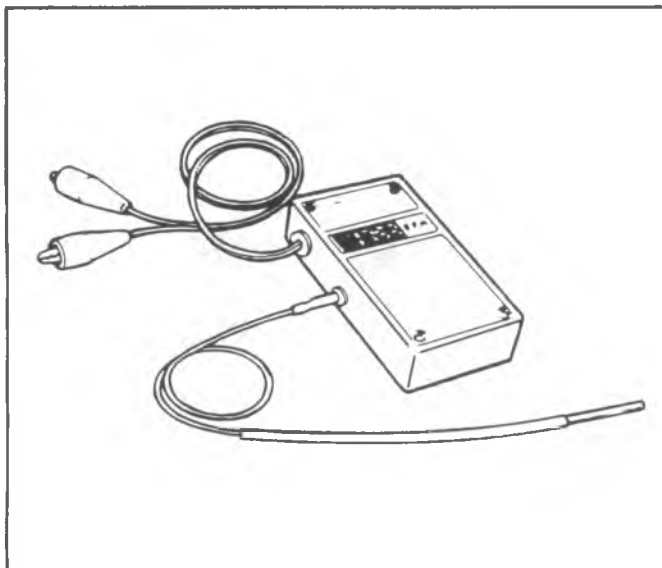

Fig. 6C6-8--Using Tool J-26925

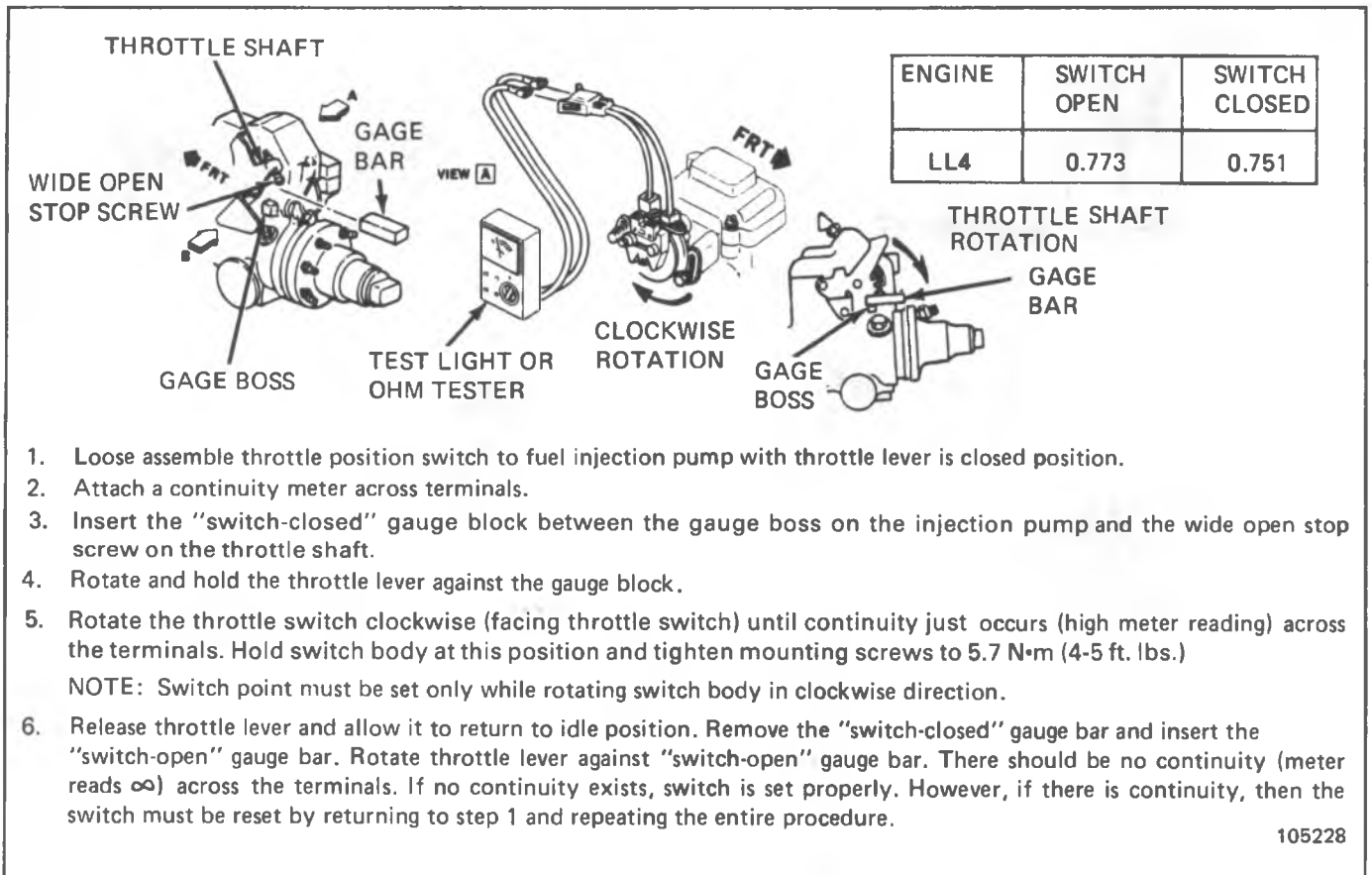

Fig. 6C6-10-T.P.S. Adjustment LL4 and 700R4 Transmission

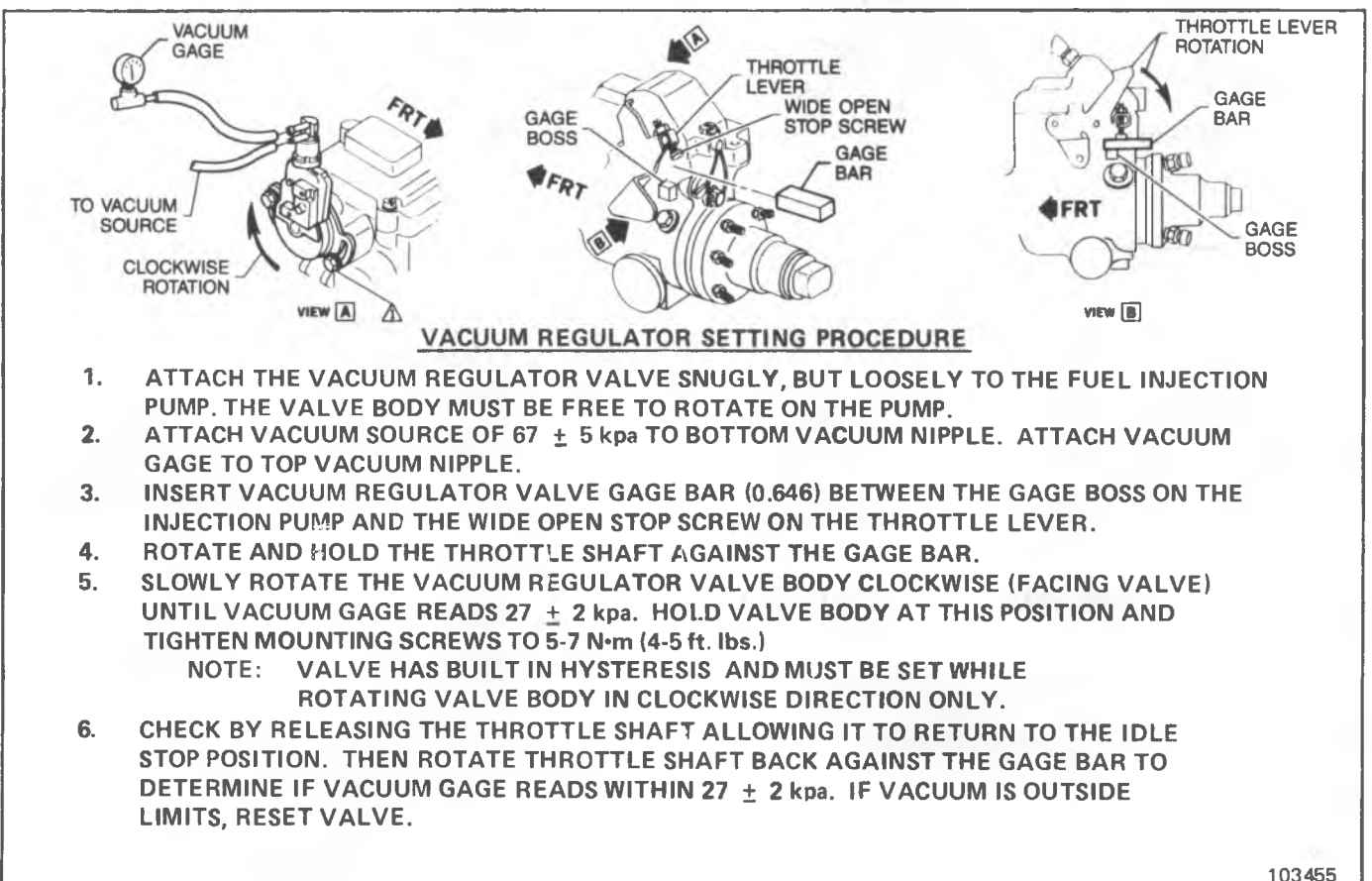

Fig. 6C6-11-V.R.V. Adjustment LL4 Engine

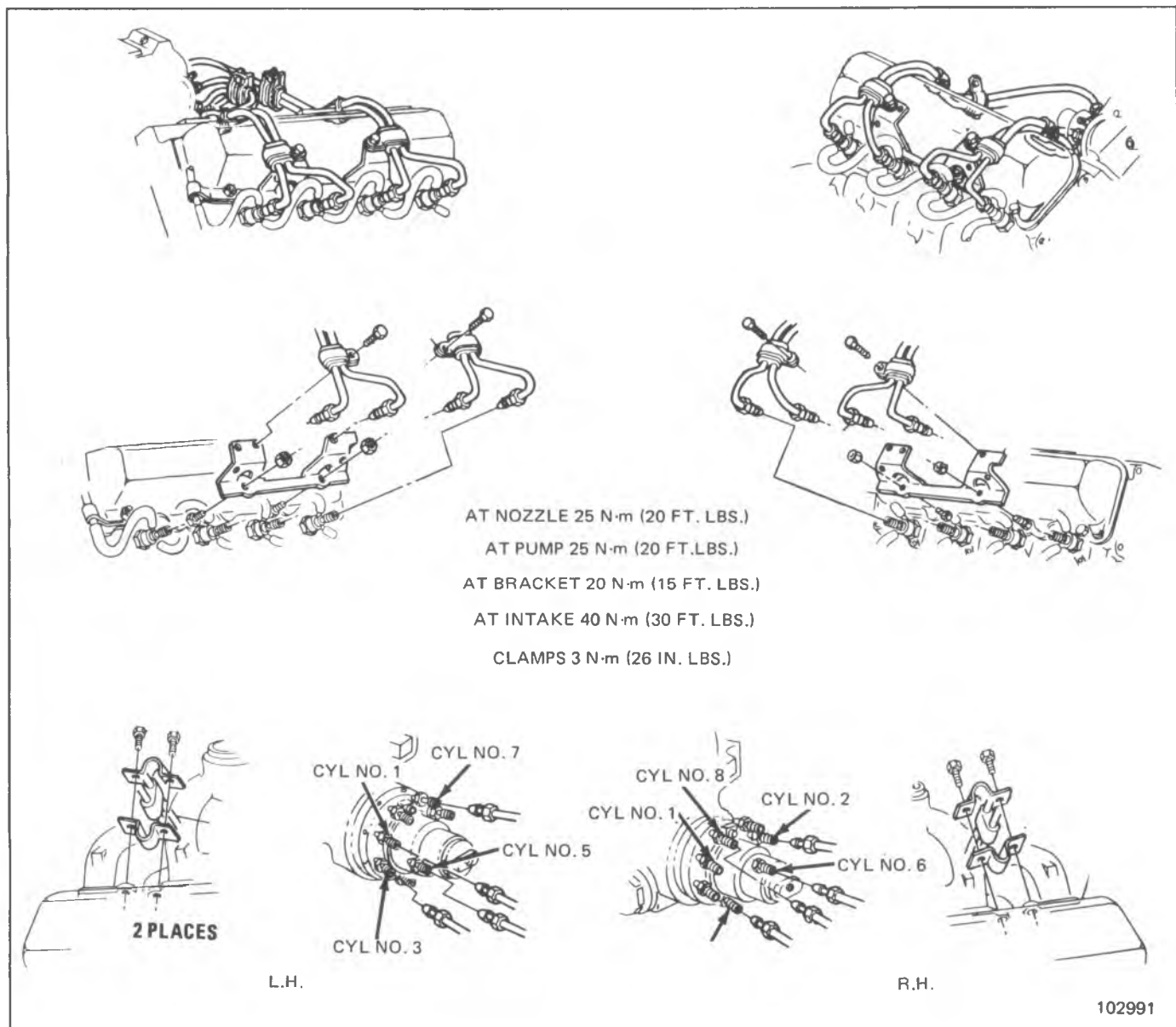

Fig. 6C6-12--Fuel Injection Lines

2. Better cold starts.
3. Improves idle when cold.

When changing the fuel filter or when the vehicle has run out of fuel, disconnect the connector from the temperature switch and jumper connector terminals. This will aid in purging air from the pump. (This procedure is necessary only on a hot engine, as the circuit will always be closed when the engine is cold).

### INJECTION PUMP FUEL LINES (FIGS. 6C6-12 and 6C6-13)

When lines are to be removed, clean all line fittings thoroughly before loosening. Immediately cap the lines, nozzles and pump fittings to maintain cleanliness.

#### CK Truck

##### Removal

1. Disconnect batteries.
2. Disconnect air cleaner bracket at valve cover.

3. Remove crankcase ventilator bracket and move aside.
4. Disconnect secondary filter lines.
5. Remove secondary filter adapter.
6. Loosen vacuum pump hold-down clamp and rotate pump in order to gain access to intake manifold bolt.
7. Remove intake manifold bolts. Injection line clips are retained by the same bolts.
8. Remove intake manifold.
9. Install protective covers J-29664-1.
10. Remove injection line clips at loom brackets.
11. Remove injection lines at nozzles and cover nozzles with protective caps.
12. Remove injection lines at pump and tag lines for reinstallation.
13. Remove fuel line from injection pump.

##### Installation

1. Install injection lines as shown in Figures 6C6-12 and 6C6-13.
2. Remove protective covers.

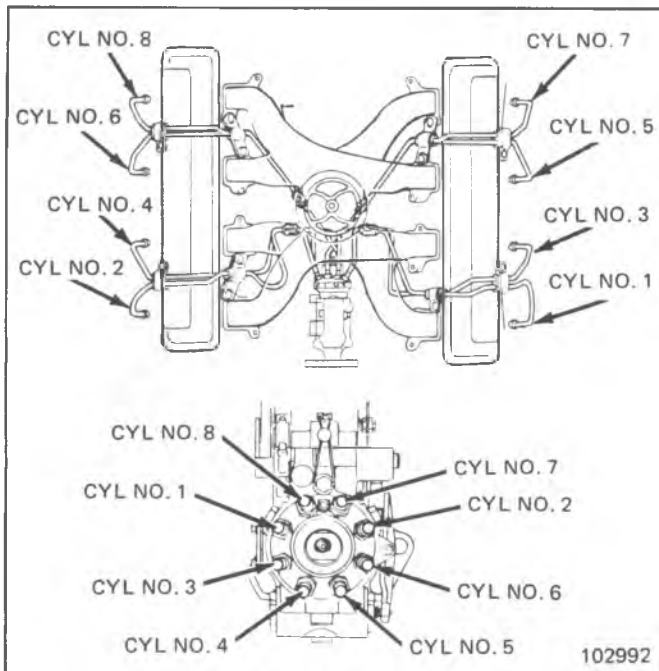

Fig. 6C6-13--Fuel Line Routing

3. Install intake manifold.
4. Install secondary filter and lines.
5. Tighten vacuum pump hold-down clamp.
6. Install crankcase ventilator.
7. Connect air cleaner.
8. Connect batteries.

### G Van

#### Removal

1. Disconnect batteries.
2. Remove engine cover.
3. Remove intake manifold as outlined in 6.2 Liter Diesel Section.
4. Install protective covers J-29664-1.
5. Remove injection line clips at loom brackets.

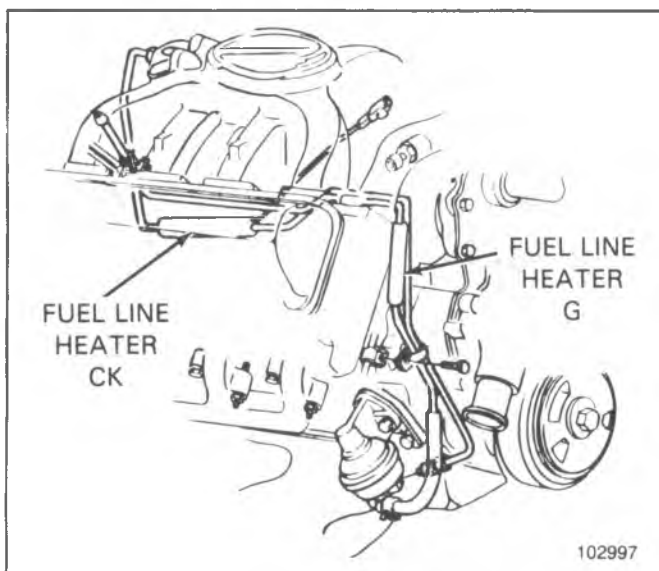

Fig. 6C6-14--Fuel Line Heater/Fuel Line

6. Raise vehicle (left bank only).
7. Remove injection lines at nozzles and cover nozzles with protective caps.
8. Lower vehicle (left bank only).
9. Remove injection lines at pump and tag lines for reinstallation.

#### Installation

1. Install injection lines as shown in Figures 6C6-12 and 6C6-13.
2. Raise and lower vehicle as necessary (left bank only).

### FUEL LINE HEATER/FUEL LINE TO PRIMARY FILTER - CK TRUCK (FIG. 6C6-14)

#### CK Truck

#### Removal

1. Disconnect batteries.
2. Remove air cleaner.
3. Remove crankcase depression regulator valve tubes from intake.
4. Disconnect secondary filter fuel lines.
5. Remove secondary filter adapter.
6. Loosen vacuum pump hold-down clamp and rotate pump in order to gain access to manifold bolts.
7. Remove intake manifold bolts.
8. Remove intake manifold.
9. Install protective covers J-29664-1.
10. Remove injection lines (except #5 and #7).
11. Cap injection lines, nozzles and pump fittings to maintain cleanliness.
12. Disconnect fuel line at fuel pump.
13. Disconnect fuel line clip.
14. Disconnect wire connector.
15. Remove fuel line heater/fuel line to primary filter.

For installation procedures, reverse removal procedures.

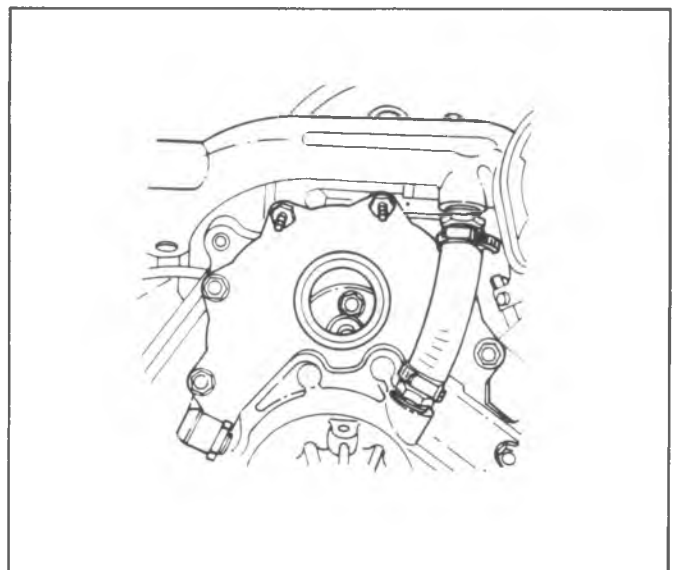

Fig. 6C6-15--Pump Drive Gear Bolts

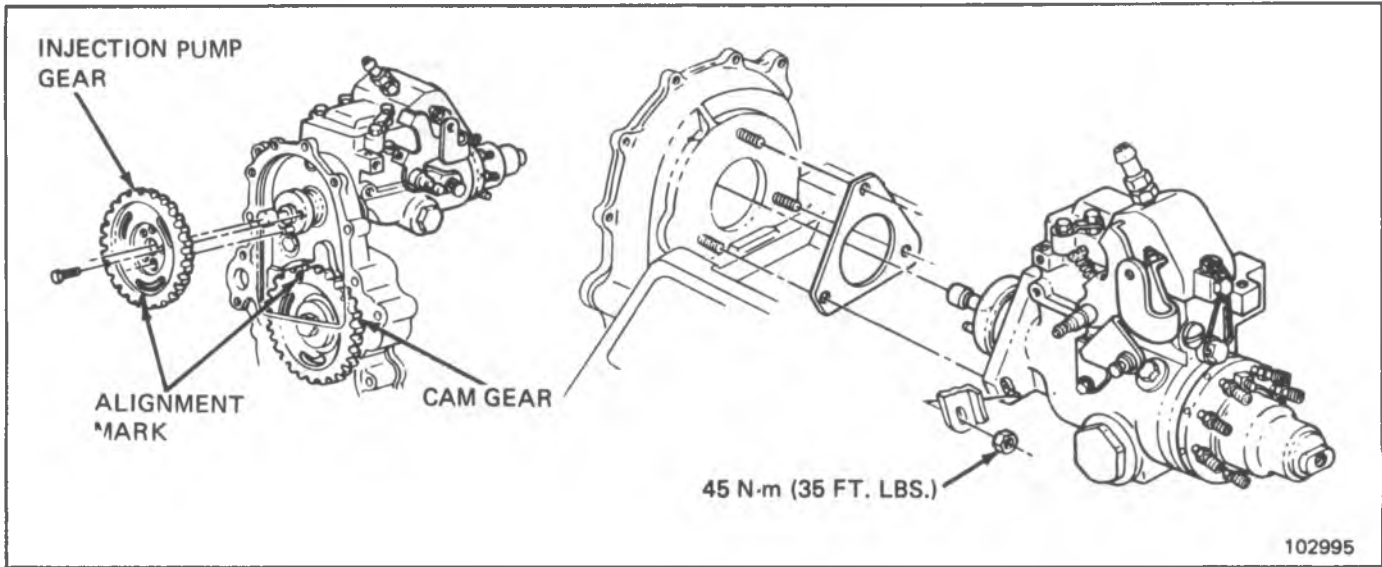

Fig. 6C6-16--Injection Pump Installation

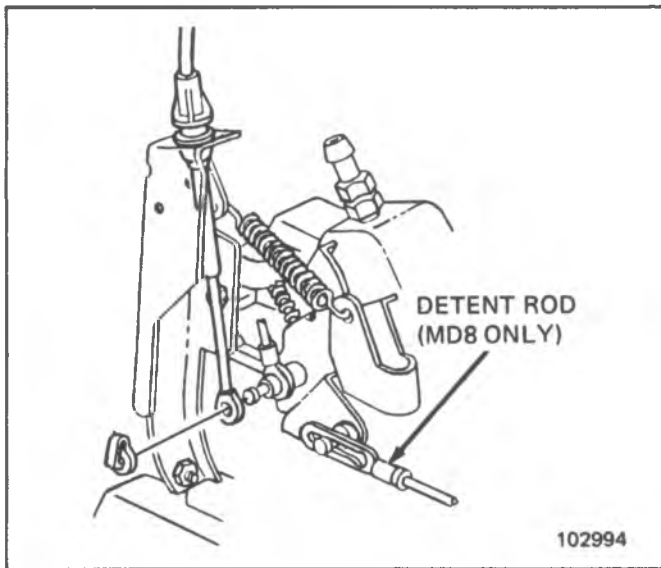

Fig. 6C6-17--Accelerator Linkage

## INJECTION PUMP

### CK Truck

#### Removal

1. Disconnect batteries.
2. Remove fan.
3. Remove fan shroud.
4. Remove intake manifold as described in 6.2 Liter Diesel Section.
5. Remove fuel lines as previously outlined.
6. Disconnect accelerator cable at injection pump, and detent cable where applicable (Fig. 6C6-16).
7. Disconnect necessary wires and hoses at injection pump.
8. Disconnect fuel return line at top of injection pump.
9. Disconnect fuel feed line at injection pump.

10. Remove A/C hose retainer bracket if equipped with A/C.
11. Remove oil fill tube, includes C.D.R.V. vent hose assembly.
12. Remove grommet.
13. Scribe or paint a mark on front cover and injection pump flange.
14. It will be necessary to rotate engine in order to gain access to driven gear to injection pump retaining bolts through the oil filler neck hole (Figure 6C6-15).
15. Remove injection pump to front cover attaching nuts.
16. Remove pump and cap all open lines and nozzles.

#### Installation

1. Replace gasket.
2. **Align locating pin on pump hub with slot in injection pump driven gear (Figure 6C6-16 and 6C6-18).** At the same time, align timing marks.
3. Attach injection pump to front cover, torque nuts

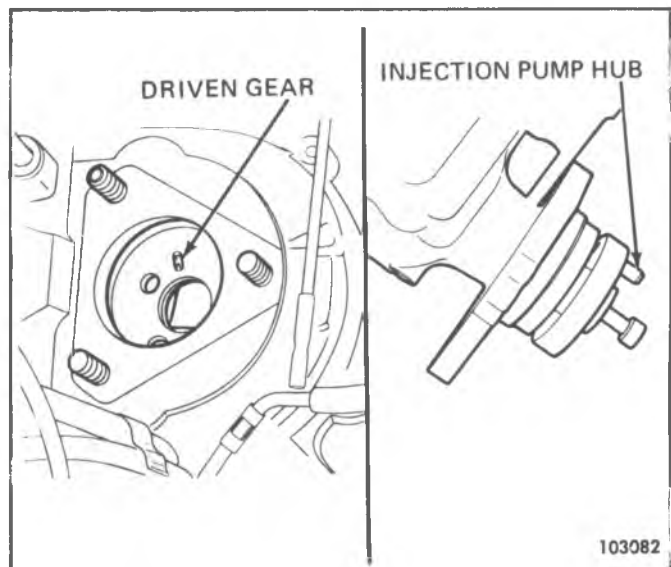

Fig. 6C6-18--Injection Pump Locating Pin

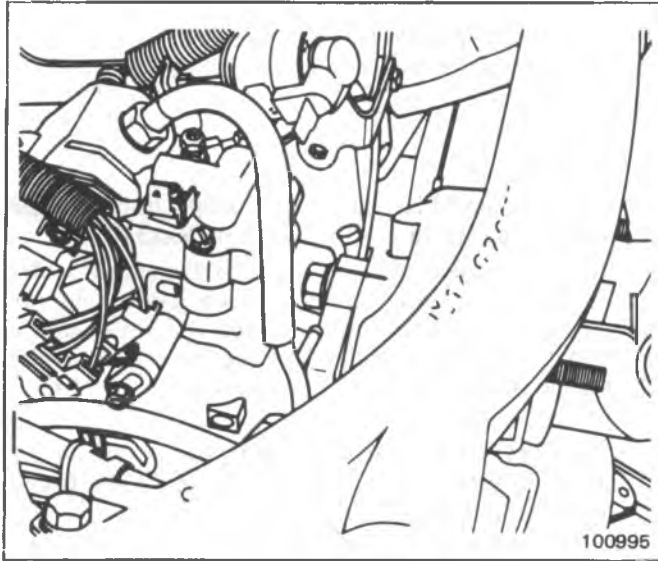

Fig. 6C6-19--Alignment Marks

to 40 N·m (30 ft. lbs.). Align timing marks before fully torquing nuts.

4. Install drive gear to injection pump bolts, torque bolts to 25 N·m (20 ft. lbs.).
5. Install oil fill tube, includes C.D.R.V. vent hose assembly.
6. Install grommet.
7. Install A/C hose retainer bracket if equipped.
8. Install fuel feed line at injection pump, torque to 25 N·m (20 ft. lbs.).
9. Install fuel return line at top of injection pump.
10. Connect necessary wires and hoses.
11. Connect accelerator cable.
12. Connect injection lines.
13. Install intake manifold.
14. Install fan shroud.
15. Install fan.
16. Connect batteries.
17. Start engine and check for leaks.

### G Van

#### Removal

1. Remove intake manifold as previously outlined.
2. Remove air cleaner inlet hose (rotate snorkel up).
3. Remove hood latch, disconnect cable and move aside.
4. Remove windshield washer bottle.
5. Remove fan shroud bolts.
6. Remove upper shroud.
7. Disconnect rubber hose from oil fill tube.
8. Disconnect oil fill tube attaching nuts and remove oil fill tube.
9. Remove oil fill tube grommet.
10. Rotate engine as necessary and remove drive gear to pump bolts.
11. Remove fuel filter and bracket -- includes line to injection pump.

12. Disconnect wire looms from injection lines.
13. Disconnect injection lines at brackets. Also disconnect oil pan dipstick tube at left cylinder head.
14. Disconnect electrical connections at injection pump.
15. If equipped with automatic transmission, disconnect T.V. cable.
16. Disconnect accelerator cable.
17. Disconnect injection lines at nozzles Numbers 2, 4, 5, 6, 7, 8.
18. Raise vehicle.
19. Disconnect Number 1 and 3 injection lines at nozzles.
20. Cover nozzles Numbers 1, 3, 5, 7.
21. Lower vehicle.
22. Cover nozzles Number 2, 4, 6, 8.
23. Disconnect injection lines at pump and remove lines. Tag lines for reinstallation.
24. Cap all lines.
25. Disconnect fuel return line.
26. Scribe a mark on front cover and pump flange for reinstallation.
27. Remove pump to front cover attaching nuts.
28. Remove injection pump and cap all open discharge fittings.

#### Installation

1. Replace gasket.
2. **Align locating pin on pump hub with slot in injection pump gear (Figure 6C6-16 and 6C6-18).** At the same time, align timing marks.
3. Attach injection pump to front cover, torque nuts to 40 N·m (30 ft. lbs.). Align timing marks before fully torquing nuts.
4. Attach pump to drive gear, torque bolts to 25 N·m (20 ft. lbs.).
5. For the remainder of installation procedures, reverse removal steps.

### CHECKING OR ADJUSTING TIMING

#### CK Truck, G Van

##### Checking

For the engine to be properly timed, the marks on the top of the engine front cover and the injection pump flange must be aligned. The engine must be off when the timing is reset. On Federal models, align scribe marks. On California models, align half circles.

##### Adjusting

If the marks are not aligned, adjustment is necessary.

1. Loosen the three pump retaining nuts.
2. Align mark on injection pump with mark on front cover and tighten nuts to 40 N·m (30 ft. lbs.).
3. Adjust throttle rod.

### MARKING TDC ON FRONT HOUSING

#### CK Truck, G Van

1. Set engine to TDC #1 cylinder (firing).
2. Install timing fixture J-33042 in F.I. pump location. Do not use gasket.

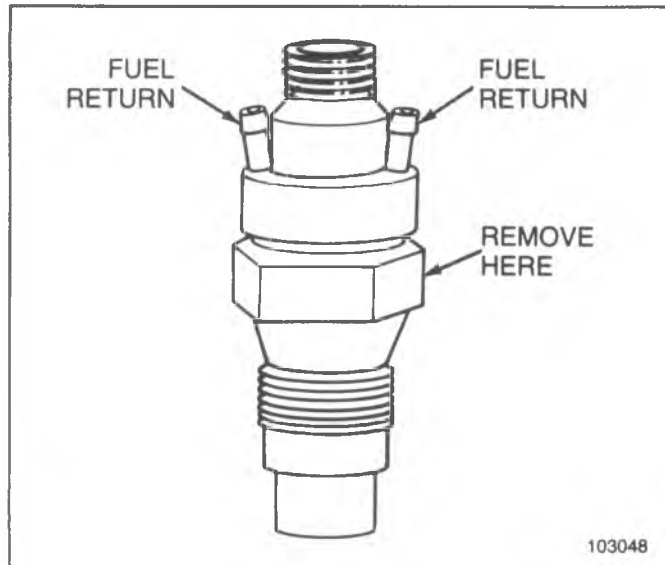

Fig. 6C6-20--Injection Nozzle

3. Slot of F.I. pump gear to be in vertical 6 o'clock position - (If not, remove fixture and rotate engine crankshaft 360°). The timing marks on gears will be aligned.
4. Fasten gear to fixture, and tighten.
5. Install on 10mm nut to housing upper stud to hold fixture flange nut to be "finger" tight.
6. Torque large bolt (18mm head) counterclockwise (toward left bank) to 50 ft. lbs. Tighten 10mm nut.
7. Insure crankshaft has not rotated (and fixture did not bind on 10mm nut).
8. Strike scribe with mallet to mark "TDC" on front housing.
9. Remove timing fixture.
10. Install fuel injection pump with gasket.
11. Install one 8mm bolt to attach gear to pump hub and tighten to specification.
12. Align timing mark on F.I. pump to front housing mark. Tighten to specification (3) 10mm attachment nuts.
13. Rotate engine and install remaining (2) pump gear attaching bolts and tighten to specification.

### INJECTION NOZZLE (Fig. 6C6-20)

Nozzles used in CK models and G models are different and are not interchangeable.

#### Removal

1. Disconnect batteries.
2. Disconnect fuel line clip.
3. Remove fuel return hose.
4. Remove fuel injection line as previously outlined.
5. Remove injection nozzle using tool J-29873 whenever possible.

**NOTICE:** When removing an injection nozzle, use tool J-29873. Be sure to remove the nozzle using the 30mm hex (Fig. 6C6-20). Failure to do so will result in damage to the injection nozzle. Always cap the nozzle and lines to prevent damage and contamination.

#### Testing

Test is comprised of the following checks:

- Nozzle Opening Pressure
- Chatter
- Leakage
- Spray Pattern

**Each test should be considered a unique test, i.e, when checking opening pressure, do not check for leakage.**

If all of the above tests are satisfied, the nozzle holder assembly can be again installed in the engine without any changes. If any one of the tests is not satisfied, the complete nozzle holder assembly must be replaced. The nozzle holder will then be further checked and repaired at a centralized location.

Test Lines - 6x2x400mm (1.5mm bore).

Test Fluid per ISO 4113 (Example Shell V1399, Viscor 1487c or equivalent).

Kinetic Viscosity at 40° per ISO 3104: 2.45...2.75mm<sup>4</sup>/second.

Test Oil Temperature during Test: 20-25°C (room temperature).

Refer to the equipment manufacturers instructions for exact test procedures.

**CAUTION:** When testing nozzles, do not place your hands or arms near the tip of the nozzle. The high pressure atomized fuel spray from a nozzle has sufficient penetrating power to puncture flesh and destroy tissue and may result in blood poisoning. The nozzle tip should always be enclosed in a receptacle, preferably transparent, to contain the spray.

#### Test Sequence

##### Preparation

1. Connect the nozzle holder assembly to the test line.
2. Place clear plastic tubes on overflow connections to prevent leakoff from being confused with actual leak..
3. Close the shutoff valve to the pressure gage.
4. **Fill and flush the nozzle holder assembly with test oil by activating the lever repeatedly and briskly. This will apply test oil to all functionally important areas of the nozzle and purge it of air.**

##### Obtaining Pressure Check

1. Open shutoff valve at pressure gage 1/4 turn.
2. Depress lever of tester slowly. Note at what pressure the needle of the pressure gage stopped. Some nozzles may pop, other may drip down at this time (this is not leakage). The maximum observed pressure is the opening pressure.
3. The opening pressure should not fall below the lower limit of 105 bar (1500 psi on used nozzles).
4. Replace nozzles which fall below the lower limit.

##### Leakage Test

1. Further open shutoff valve at pressure gage (1/2 to 1-1/2 turns).
2. Blow-dry nozzle tip.
3. Depress lever of manual test stand slowly until



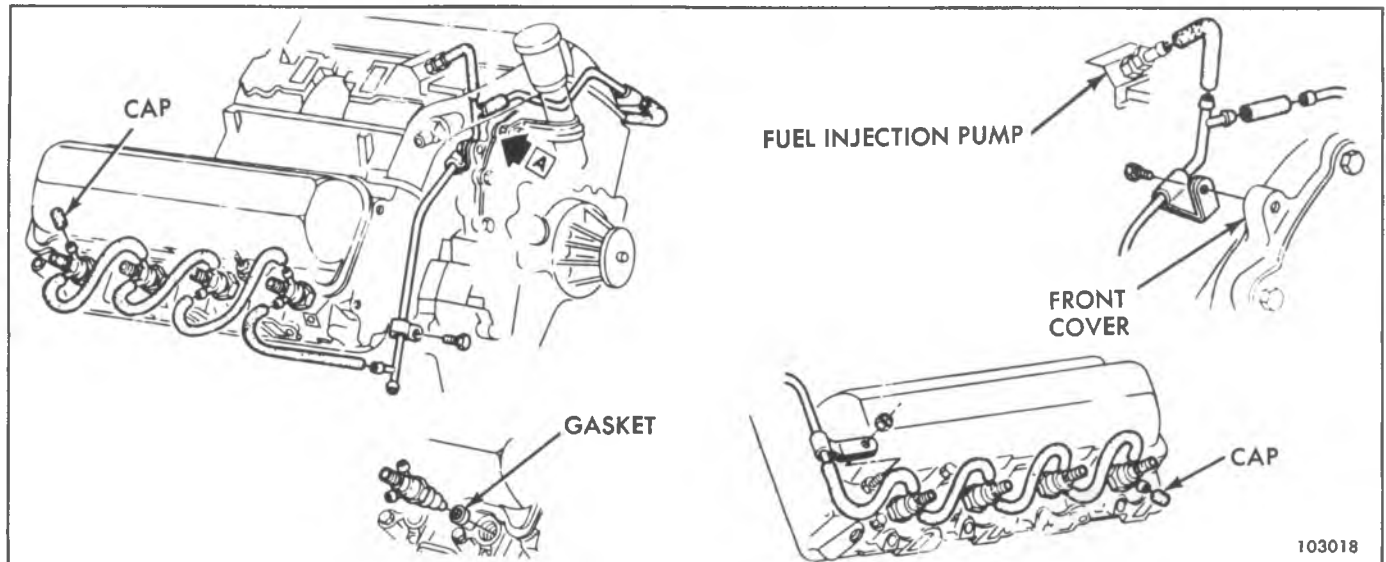

Fig. 6C6-21--Nozzle Installation

gauge reads a pressure of 95 bar (1400 psi). Observe tip of nozzle. A drop may form but not drop off within a period of 10 seconds.

4. Replace the nozzle holder assembly if a droplet drops off the nozzle bottom within the 10 seconds.

#### Chatter Test

When testing for chatter, it should be noted that the sound (chatter) for new and used nozzles may vary.

On used nozzles, carbonized fuel oil deposited on the pintle and on the nozzle tip produces different sound (chatter) between new and used nozzles on the test stand.

With some used nozzles, the chatter is difficult to detect during slow actuation of the hand test stand lever. Some nozzles may chatter more (louder) than others. As long as there is chatter, the nozzle is acceptable.

1. Close shutoff lever at pressure gauge.
2. Depress lever of manual test stand slowly noting whether chatter noises can be heard.
3. If no chatter is heard, **increase the speed of lever movement until it reaches a point where the nozzle chatters.** At fast lever movement, the nozzle may emit a "hissing" or "squealing" sound rather than the normal "chatter", this is acceptable.
4. These sounds indicate that the nozzle needle moves freely and that the nozzle seat, guide, as well as the pintle, have no mechanical defects.
5. Replace nozzles which do not chatter.

#### Spray Pattern

This nozzle features a longer nozzle overlap, greater pintle to body clearance, and greater needle to body clearance. This assembly also features an internal wave washer between the nozzle nut and nozzle. Because of these features, objective testing is difficult. **A pop tester will not deliver fuel with the velocity necessary to obtain proper spray pattern analysis. Based on the above, this type nozzle should not be rejected for spray pattern.**

#### Installation (Fig. 6C6-21)

1. Remove protective caps from nozzle.

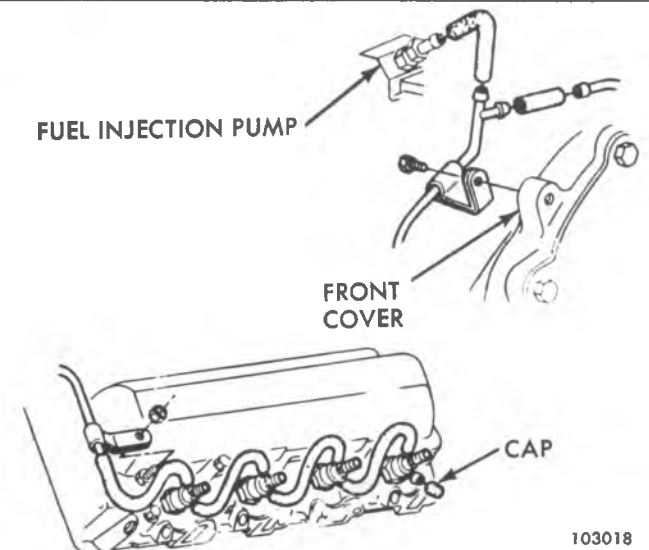

2. Install nozzle and torque to 70 N·m (50 ft. lbs.).
3. Connect fuel injection line, torque nut to 25 N·m (20 ft. lbs.).
4. Install fuel return hose.
5. Install fuel line clip.
6. Connect battery.

## INJECTION PUMP ON VEHICLE SERVICE

There are areas on the injection pump where leaks can be corrected without removing the pump from the engine.

### PUMP COVER SEAL AND/OR GUIDE STUD SEAL REPLACEMENT

1. Disconnect the negative cables from both batteries.
2. Remove the air cleaner and intake. Install screens J-29664 in the cylinder head.
3. Disconnect the injection pump fuel solenoid and housing pressure cold advance wires and the fuel return pipe.
4. Remove top attaching bolt and loosen lower attaching bolts on fast idle solenoid and move solenoid aside.
5. Clean the injection pump cover, upper portion of the pump and the guide stud area. Place several rags in engine valley to catch fuel.
6. Remove injection pump cover and remove screws from the cover.

**NOTICE:** Extreme care must be exercised to keep foreign material out of the pump when the cover is off. If any objects are dropped into the pump, they must be removed before the engine is started or injection pump damage or engine damage could occur. **STEPS 7, 8 and 9 ARE FOR GUIDE STUD SEAL REPLACEMENT ONLY.**

7. Observe position of metering valve spring over the top of the guide stud. This position must be exactly duplicated during reassembly (Fig. 6C6-23).
8. Remove the guide stud and washer. Note location of parts prior to removal.
9. Reinstall the guide stud with a new washer making



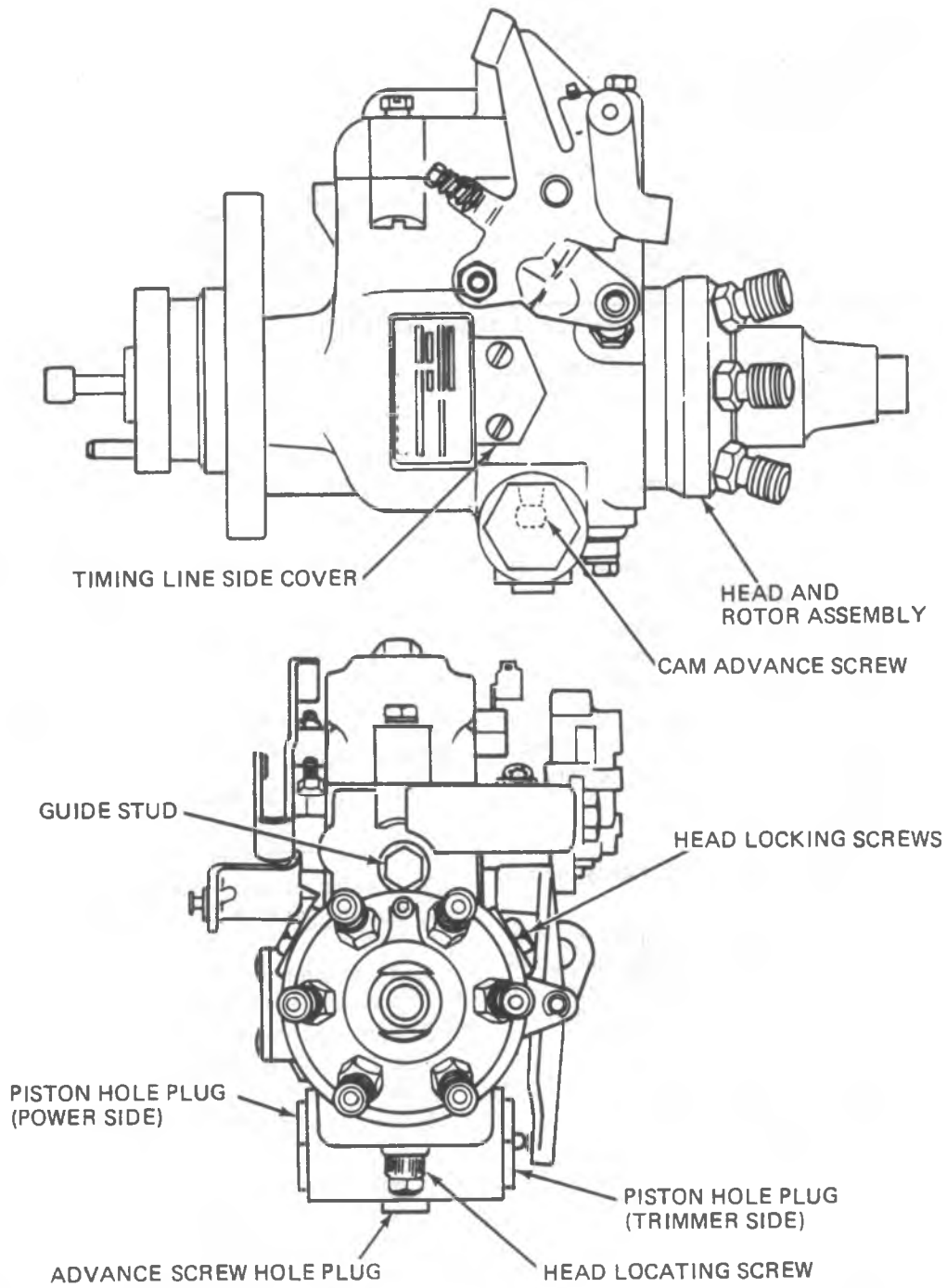

103148

Fig. 6C6-22--Injection Pump Components Location

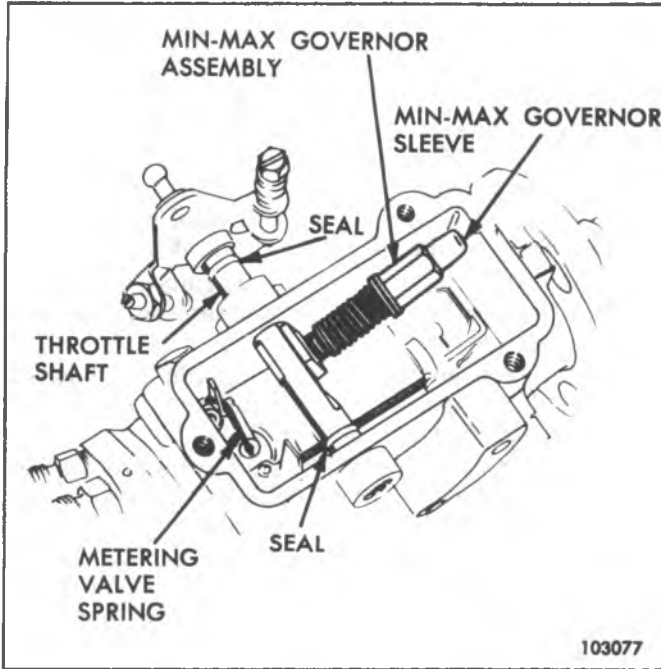

Fig. 6C6-23--Injection Pump Cover Removed

certain that the upper extension of the metering valve spring rides on top of the guide stud. Torque the guide stud to 9.5 N·m (85 in. lbs.). Overtorquing the guide stud may strip the aluminum threads in the housing

10. Hold the throttle in the idle position.
11. Install new pump cover seal. Make sure the screws are not in the cover and position the cover about 1/4 inch forward (toward shaft end) and about 1/8 inch above the pump (Fig. 6C6-24).
12. Move the cover rearward and downward into position, being careful not to cut the seal and reinstall the cover screws. Be careful not to drop or lose flat washer and internal lock washer with each screw. Flat washer must be against pump cover. Torque to 3.7 N·m (33 in. lbs.).
13. Reconnect the negative cables to both batteries.

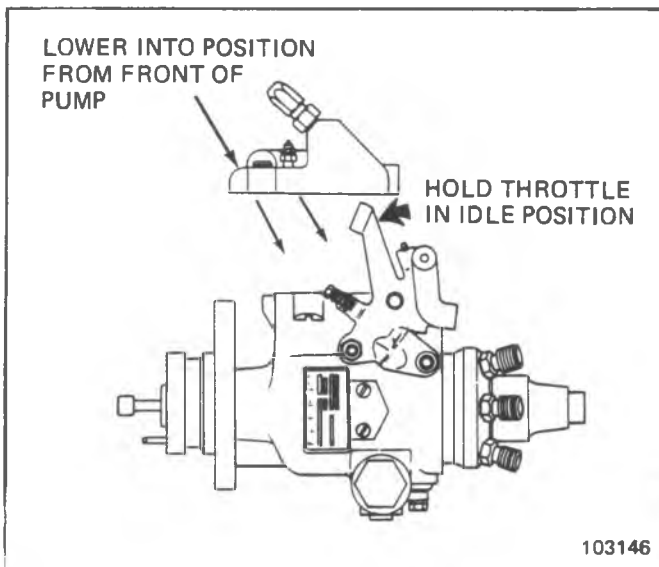

Fig. 6C6-24--Installing Injection Pump Cover

14. Turn the ignition switch to the run position and touch the pink solenoid wire to the solenoid. A clicking noise should be heard as the wire is connected and disconnected. If this clicking is not observed, the linkage may be jammed in a wide open throttle position and the engine **MUST NOT** be started, go to Step 15. If clicking is observed, connect the pump solenoid and housing pressure cold advance wires (Fig. 6C6-25 ) then proceed to Step 17.
15. Remove the cover. Ground the solenoid lead (opposite the hot lead) and connect the pink wire. With the ignition switch in the run position, the solenoid in the cover should move the linkage. If not, the solenoid must be replaced. Minimum voltage across solenoid terminals must be 12.0.
16. Reinstall the cover and repeat Step 11, 12, 13, and 14.
17. Reinstall the fuel return pipe and the throttle cable and return springs, and reposition fast idle solenoid.
18. Start the engine and check for leaks.
19. Idle roughness may be observed due to the air in the pump, give it plenty of time to purge which it will do by allowing the engine to idle. It may be necessary to shut the engine down for several minutes to allow air bubbles to rise to the top of the pump where they will be purged.
20. Remove the intake manifold screens, then reinstall the intake and air cleaner.

**THROTTLE SHAFT SEAL REPLACEMENT**

1. Disconnect the negative cables from both batteries.
2. Remove the air cleaner and intake. Install screens in the cylinder head J-29664.
3. Disconnect the injection pump fuel solenoid and housing pressure cold advance wires and the fuel return pipe.
4. Mark the position of the T.P.S. switch or vacuum regulator valve for reinstallation, remove the throttle rod and return springs. Loosen and move aside the fast idle solenoid.

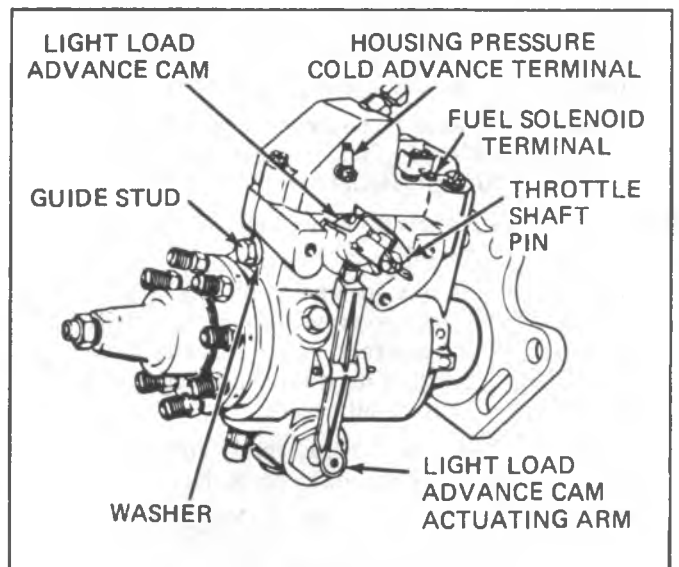

Fig. 6C6-25--Injection Pump Housing Right Side View Typical

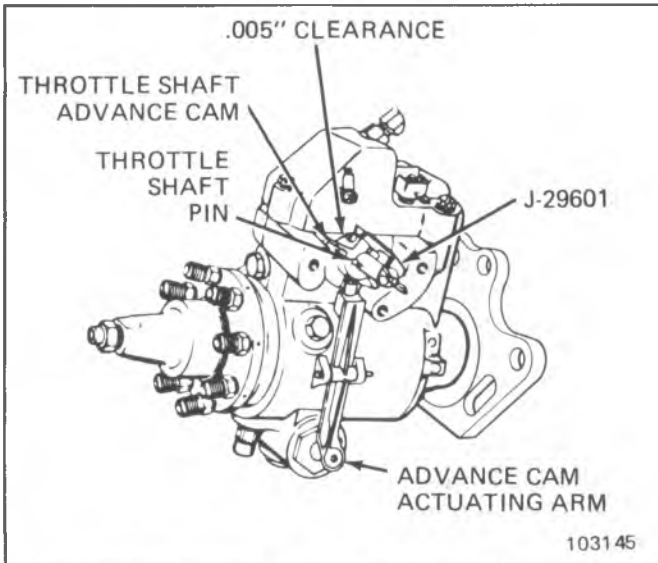

Fig. 6C6-26--Injection Pump With Tool J29601 Installed

5. Remove the throttle cable bracket.
6. Install tool J-29601 over the throttle shaft with slots of tool engaging pin. Put the spring clip over the throttle shaft advance cam and tighten the wing nut. Without loosening the wingnut, pull the tool off the shaft. (This provides the proper alignment on reassembly) (Fig. 6C6-26). Loosen face cam screw.
7. Drive the pin from the throttle shaft and remove the throttle shaft advance cam and fiber washer. Remove any burrs from the shaft that may have resulted from pin removal.
8. Clean the injection pump cover, upper portion the pump, the throttle shaft and the guide stud area. Place several rags in the engine valley to catch fuel.
9. Remove injection pump cover and remove screws from the cover.
 

**NOTICE:** Extreme care must be exercised to keep foreign material out of the pump when the cover is off. If any objects are dropped into the pump, they must be removed before the engine is started or injection pump damage or engine damage could occur.
10. Observe position at metering valve spring over the top of the guide stud. This position must be exactly duplicated during reassembly (Fig. 6C6-27).
11. Remove the guide stud and washer. Note location of parts prior to removal.
12. Rotate the min-max governor assembly up to provide clearance and remove from the throttle shaft (Fig. 6C6-23). If idle governor spring becomes disengaged from throttle block, it must be reinstalled with tightly wound coils toward throttle block.
13. Remove the throttle shaft assembly and examine the shaft for unusual wear or damage, replace if required.
14. Examine the throttle shaft bushings in the pump housing for any evidence of damage or unusual wear and leaks. Remove the pump and send to the local Stanadyne dealer if bushing replacement is necessary.

15. Remove the throttle shaft seals. Do not attempt to cut the seals to remove, as nicks in the seal seat will cause leakage.
16. Install new shaft seals using care not to cut the seals on the sharp edges of the shaft. Apply J-33198 Synkut oil or a light coating of clean chassis grease on the seals.
17. Carefully slide the throttle shaft back into the pump to the point where the min-max governor assembly will slide back onto the throttle shaft (Fig. 6C6-23).
18. Rotate the min-max governor assembly downward, hold in position and slide the throttle shaft and governor into position.
19. Install a new mylar washer, the throttle shaft advance cam, (do not tighten cam screw at this time), and a new throttle shaft drive pin (Fig. 6C6-25).
20. Align the throttle shaft advance cam so tool J-29601 can be reinstalled over the throttle shaft, pin in the slots and the spring clip over the advance cam.
21. Insert a .005" feeler gage between the white washer on the throttle shaft and the pump housing. Squeeze the throttle shaft and tighten the cam screw. Torque to 3.1 N·m (30 in. lbs.) and secure with Loctite 290 or equivalent. Remove tool J-29601 (Fig. 6C6-28).
22. Reinstall the guide stud with a new washer, making certain that the upper extension of the metering valve spring rides on top of the guide stud. Torque the guide stud to 9.5 N·m (85 in. lbs.). Overtorquing the guide stud may strip the aluminum threads in the housing (Fig. 6C6-25).
23. Hold the throttle in the idle position.
24. Install new pump cover seal. Make sure the screws are not in the cover and position the cover about 1/4 inch forward (toward shaft end) and about 1/8 inch above the pump (Fig. 6C6-24).
25. Move the cover rearward and downward into position, being careful not to cut the seal and reinstall the cover screws. Be careful not to drop and lose flat washer and internal lock washer with each screw. Flat washer must be against pump cover. Torque to 3.7 N·m (33 in. lbs.).

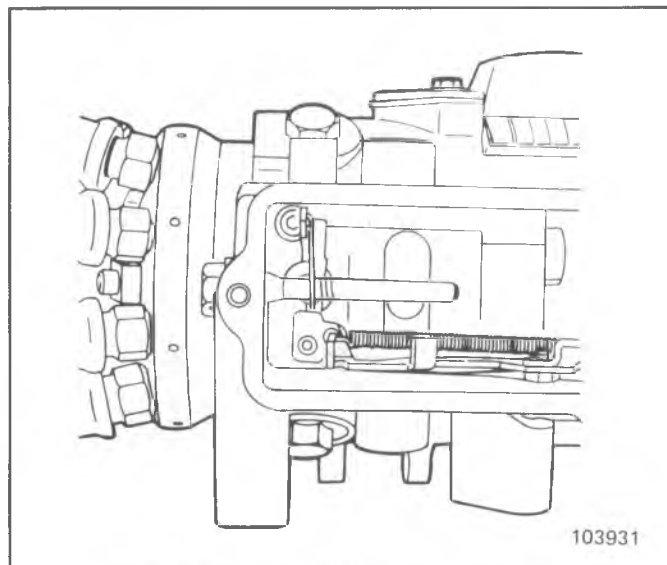

Fig. 6C6-27--Metering Valve Spring Position

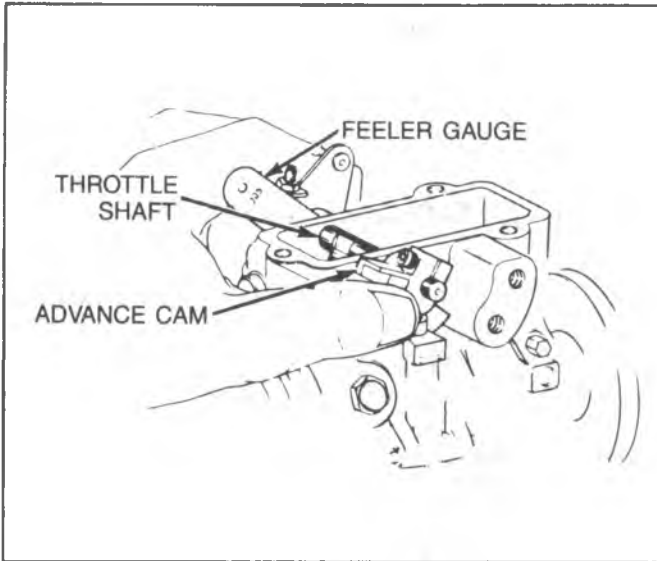

Fig. 6C6-28--Feeler Gage Installation

Install vacuum regulator valve or T.P.S. switch as outlined.

26. Reconnect the negative cables to both batteries.
27. Turn the ignition switch to the run position and touch the pink solenoid wire to the solenoid. A clicking noise should be heard as the wire is connected and disconnected. If this clicking is not observed, the linkage may be jammed in a wide open throttle position and the engine **MUST NOT** be started. If clicking is observed, connect the pump solenoid and housing pressure cold advance wires (Fig. 6C6-25), then proceed to Step 30.
28. Remove the cover. Ground the solenoid lead (opposite the hot lead) and connect the pink wire. With the ignition switch in the run position, the solenoid in the cover should move the linkage. If not, the solenoid must be replaced. Minimum voltage across solenoid terminals

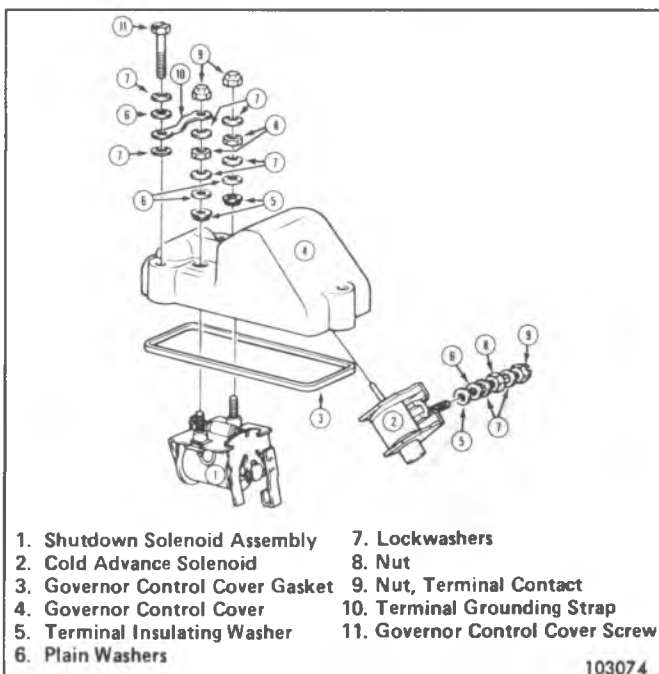

Fig. 6C6-29--Solenoids

must be 12.0.

29. Reinstall the cover and repeat Step 27.
30. Reinstall throttle cable bracket, detent cable and fast idle solenoid.
31. Reinstall the throttle cable and return springs. Make sure the timing mark on the pump and housing are aligned and make sure the nuts attaching pump to the housing are tight. Install fuel return pipe.
32. Start the engine and check for leaks.
33. Idle roughness may be observed due to the air in the pump, give it plenty of time to purge which it will do by allowing the engine to idle. It may be necessary to shut the engine down for several minutes to allow air bubbles to rise to the top of the pump where they will be purged.
34. Remove the head screens, then reinstall the intake and air cleaner.

### SOLENOIDS (Fig. 6C6-29)

#### Removal

1. Remove the pump cover, see "Pump Cover Seal".
2. Remove the terminal contact nut(s) and remove the solenoid from the cover noting the position of any insulating washers.

#### Installation

1. Place the solenoid in the cover making certain on the shut off solenoid that the linkage is free and on the housing pressure cold advance solenoid that the plunger is centered so that it will contact the fitting check ball.
2. Place the insulating washers on the terminal studs (where used) and install the terminal nuts. Torque the nuts to 1.00-1.5 N·m (10-15 in. lbs.).
3. Check the operation of the solenoid prior to installing the pump cover with the use of a 12V (min) DC power source. Make certain that the shut off linkage is free if that solenoid was replaced.
4. Install the pump cover, see "Pump Cover Seal", Steps 9 through 19.

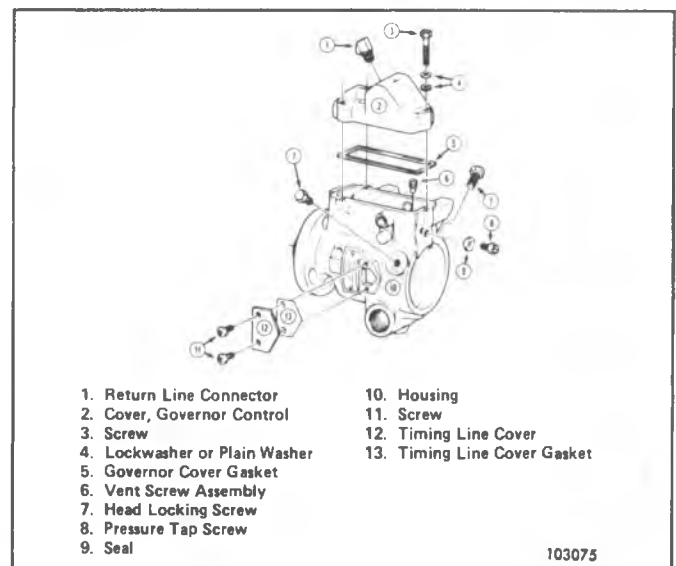

Fig. 6C6-30--Side Housing and Drive Group

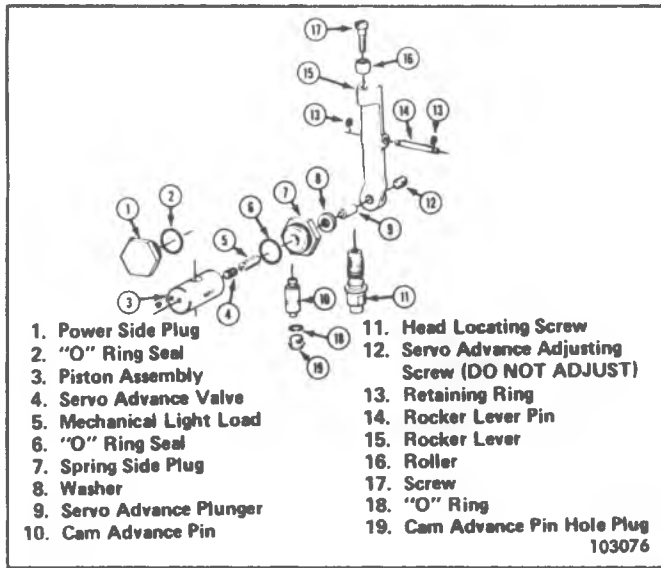

Fig. 6C6-31--Automatic Advance Group

**SIDE COVER GASKET (Fig. 6C6-30)**

**Removal**

1. Remove the 2 screws, cover and gasket.

**Installation**

1. Install the gasket, cover and two screws, torque the screws to 1.5-2.5 N·m (15-20 in. lbs.).

**INJECTION PUMP OFF-VEHICLE SERVICE**

Refer to Injection Pump removal. Off-vehicle service operations require a leak test after repair. See Pressure Testing.

**ADVANCE PIN HOLE PLUG SEAL (Fig. 6C6-31)**

**Removal**

1. Tap the advance pin hold plug lightly with a hammer to loosen.
2. Loosen and remove the plug, remove the seal and do not reuse it.

**Installation**

1. Lube a new seal and install it on the plug.
2. Install the plug and torque it to 8.5-11.0 N·m (75-100 in. lbs.).

**AUTO ADVANCE SEALS (Fig. 6C6-31)**

**Removal**

1. Remove the advance pin hole plug as stated in "ADVANCE PIN HOLE PLUG".
2. Remove the spring side advance piston hold plug.
3. Remove the plug, piston, spring and slide washer.
4. Remove the power side advance piston hole plug.
5. Remove the plug, piston and slide washer.
6. Disassemble both plugs and pistons.

**Installation**

1. Lube the new seals and reassemble as shown in Fig. 6C6-31.
2. Torque the plugs to 27 N·m (20 ft. lbs.).
3. Install the advance screw hole plug using a new seal. Torque to 8.5-11.0 N·m (75-100 in. lbs.).

**HYDRAULIC HEAD SEAL - O-RING**

**Removal**

1. Remove the throttle shaft and seals, see "THROTTLE SHAFT SEAL REPLACEMENT".
2. Remove the metering valve (Fig. 6C6-23).
3. Remove the housing vent screw assembly (Fig. 6C6-30).
4. Remove the advance pin hole plug, see "ADVANCE PIN HOLE PLUG".
5. Remove the Advance Pin (Fig. 6C6-31).
6. Locate the pump assembly and holding fixture so that the rear of pump is sloping down and remove the head locating screws and seal.
7. Using a twisting motion, remove the hydraulic head assembly. Remove the "O" ring seal.

**Installation**

1. Install a new hydraulic head seal and lube it.
2. Install the head assembly into the pump housing, lube and install the two head locking screws finger tight. Turn the pump upside down.
3. Lube and install a new seal on the head locating screw and install the screw torquing it to 20-25 N·m (15-18 ft. lbs.) (Fig. 6C6-31).
4. Torque the head locking screws to 20-25 N·m (15-18 ft. lbs.) (Fig. 6C6-30).
5. Install the advance pin (Fig. 6C6-21).
6. Install the advance pin hole plug and seal. See "ADVANCE PIN HOLE PLUG".
7. Move the pump so the cover opening is up, and install the metering valve.
8. Install the throttle shaft, seals and pump cover,

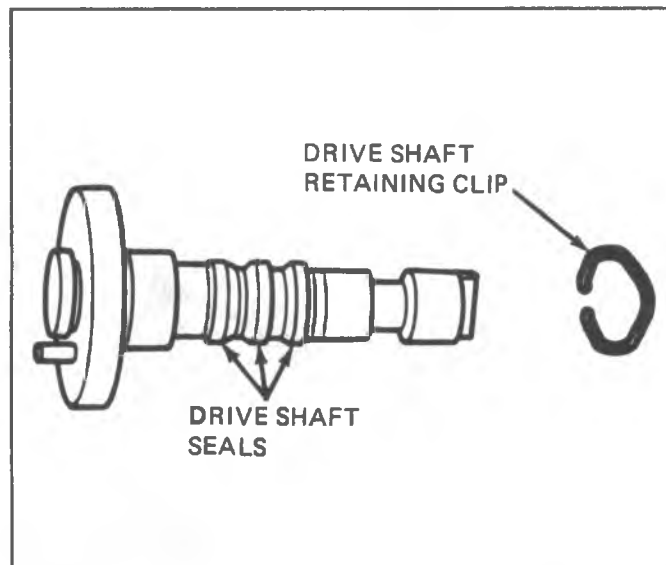

Fig. 6C6-32--Drive Shaft Seal Removal

see "THROTTLE SHAFT AND SEALS".

## DRIVE SHAFT SEAL REPLACEMENT

### Removal

1. Disconnect necessary wires, hoses and cables from the injection pump.
2. Remove the injection pump as outlined previously.
3. Mount the pump in holding fixture J-29692-B, and tilt the pump slightly towards you.
4. Remove the fast idle solenoid bracket.
5. Clean the injection pump cover upper portion of the pump.
6. Remove (3)three governor cover hold down screws and the governor cover. Discard the governor cover gasket.
7. Extreme care must be exercised to keep foreign material out of the pump when the cover is off. If any objects are dropped into the pump, they must be removed before the cover is installed or injection pump or engine damage could occur.
8. Observe the position of the metering valve spring. The spring should be over the top of the guide stud. This position must be exactly duplicated during reassembly.
9. Remove the guide stud and guide stud washer. Discard the guide stud washer.
10. Remove the min-max governor by rotating the throttle shaft.
11. Rotate the drive shaft until the hump on the retaining clip is visible. This will aid in removing the retaining clip.
12. Using tool J-9553-01, pull the drive shaft retaining clip off of the drive shaft. The retaining clip will become straightened and must be discarded.
13. Remove the drive shaft (alignment pin at top).
14. Remove and discard the drive shaft seals.

### Installation

1. Install new seals using tool J-29745-A.
2. Lubricate the seal installer with Synkut oil J-33198 or the equivalent.
3. Install one black seal.
4. Relubricate the seal installer and install the red seal.
5. Relubricate the seal installer and install the last black seal.
6. Install a new retaining clip on the drive shaft. Do not spread the clip so large that it becomes loose in the drive shaft retaining clip slot.
7. Carefully install the drive shaft, making sure that the drill points on the drive shaft end and the rotor are matched.
8. Install the min-max governor.
9. Install the guide stud using a new guide stud washer. Be sure the guide is under the metering valve spring.
10. Install the governor cover using the new governor cover gasket.
11. Install the fast idle solenoid bracket.
12. Install the pump as previously outlined.

## PRESSURE TESTING

1. Drain all fuel from the pump.
2. Connect an air line to the pump inlet connection. Be certain that the air supply is clean and dry.
3. Seal off the return line fitting and completely immerse the pump in a bath of clean test oil.
4. Raise the air pressure in the pump to 137.9 kpa (20 psi). Leave the pump immersed in the oil for 10 minutes to allow any trapped air to escape.
5. Watch for leaks after the 10 minute period. If the pump is not leaking, reduce the air pressure to 13.8 kpa (2 psi) for 30 seconds. If there is still no leak, increase the pressure to 137.9 kpa (20 psi). If still no leaks are seen, the pump is ready for use.

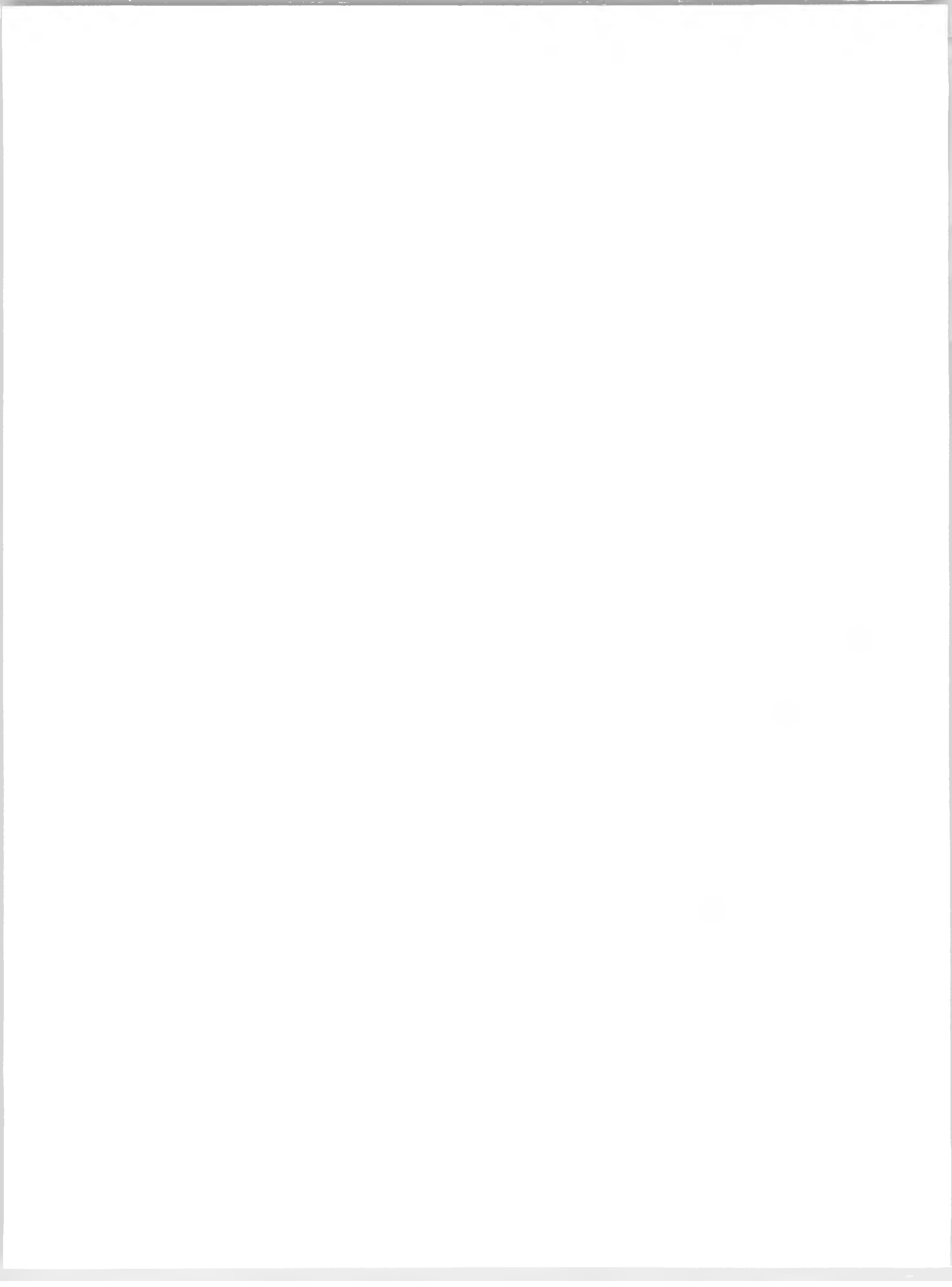

## SECTION 6D

# ENGINE ELECTRICAL

### CONTENTS

|   |  |
|---|--|
| <b>ELECTRICAL SYSTEM GENERAL DIAGNOSIS</b> ..... 6D-1<br><b>ELECTRIC CHOKE HEATER</b> ..... 6D-1<br><b>CHECKING PROCEDURE</b> ..... 6D-1<br><b>CHECK ENGINE LIGHT</b> ..... 6D-1<br><b>BATTERY</b> ..... 6D-4<br><b>CHARGING SYSTEM</b> ..... 6D-21 | <b>DIESEL ELECTRICAL SYSTEM</b> ..... 6D-32<br><b>IGNITION SYSTEM</b> ..... 6D-46<br><b>CRANKING SYSTEM</b> ..... 6D-74<br><b>ENGINE WIRE HARNESS</b> ..... 6D-67<br><b>SPECIFICATIONS</b> ..... 6D-88 |
|---|--|

For vehicles sold in Canada and equipped with non-closed loop engines,  
also refer to the appropriate Canadian Service Manual Supplement.

## ELECTRIC CHOKE HEATER-OIL PRESSURE SWITCH

All carbureted gasoline engines without gage instrumentation have a two terminal oil pressure switch to control current to the electric choke heater. This switch also provides for the illumination of the "Oil" or "Check Engine" indicator lamp. On vehicles with gages, a choke heater relay is used to control current to the choke heater and provide for the illumination of the "Choke" warning indicator. Refer to the Body and Chassis Electrical Wiring Diagram for choke heater and associated indicator lamp circuitry.

### ELECTRIC CHOKE HEATER CHECKING PROCEDURE

1. Allow choke to cool so that when throttle is opened slightly, choke blade fully closes.

This check must be performed with engine not running and at an ambient temperature of 60°C to 27°C, (140°F to 80°F).

2. Start engine and determine time for choke blade to reach full open position. (Start timer when engine starts).
3. If the choke blade fails to open fully within 3.5 minutes, proceed with steps 4-5-6 below.
4. Check voltage at the choke heater connection. (Engine must be running). If the voltage is approximately 12-15 volts, replace the electrical choke unit.
5. If the voltage is low or zero, check all wires and connections. No gasket is used between the choke cover and the choke housing because of grounding requirements. If any connections in the oil pressure switch circuitry are faulty or if the oil pressure switch is failed open, the oil warning light will be on with the engine running. Repair wires or connections as required.
6. If all wiring and connections are good, replace oil pressure switch.

## CHECK ENGINE LIGHT

The instrument panel "Check Engine" light is an integral part of the Computer Command Control System.

Refer to the Emissions Section for a detailed description of its operation and use, as a diagnostic indicator.

## GENERAL ELECTRICAL SYSTEM DIAGNOSIS

Engine electrical system diagnosis includes the battery, ignition (primary and secondary) starter (and related wiring) and the generator (and related wiring). The

following diagnosis charts will aid in troubleshooting system faults. When a fault is traced to a particular component, refer to that components section of the service manual.



**SLOW CRANKING, SOLENOID CLICKS OR CHATTERS**

**CHECK:**

**BATTERY FOR GREEN INDICATOR.**

**VISUAL CONDITION OF BATTERY CABLES AND CONNECTIONS.**

**IF BATTERY NEEDS CHARGING, MAKE GENERATOR AND BATTERY DRAIN CHECK, CHARGE BATTERY AND RECHECK CRANKING. IF TROUBLE HAS NOT BEEN FOUND, PROCEED.**

**REMOVE BATTERY LEAD FROM DISTRIBUTOR ON HEI. MAKE ALL VOLTMETER READINGS WITH KEY IN START POSITION.**

**MEASURE CRANKING VOLTAGE AT BATTERY TERMINAL POSTS.**

**9.6 VOLTS OR MORE**

**LESS THAN 9.6 VOLTS**

**MEASURE VOLTAGE FROM BATTERY NEGATIVE TERMINAL TO ENGINE BLOCK. (POS. LEAD ON BLOCK.)**

**CHECK BATTERY CONDITION AND CAPACITY**

**.5 VOLT OR MORE**

**LESS THAN .5 VOLT**

**OK**

**DEFECTIVE**

**REPAIR GROUND CABLE AND CONNECTIONS**

**MEASURE VOLTAGE AT SOLENOID "B" TERMINAL, CLEAN AND TIGHTEN CONNECTIONS AT STARTER.**

**REPAIR STARTER**

**REPLACE BATTERY**

**9 VOLTS OR MORE**

**LESS THAN 9 VOLTS**

**REPAIR STARTER**

**CLEAN AND TIGHTEN POSITIVE CABLE CONNECTIONS. IF OK, REPLACE CABLE.**

**NOTE: THIS PROCEDURE IS DESIGNED FOR USE ON ENGINES AND BATTERIES AT ROOM OR NORMAL OPERATING TEMPERATURES. IT ALSO ASSUMES THERE ARE NO ENGINE DEFECTS WHICH WOULD CAUSE CRANKING PROBLEMS. TO USE IT UNDER OTHER CONDITIONS MIGHT RESULT IN MISDIAGNOSIS.**

Fig. 6D-1--General Electrical System Diagnosis 1 of 2

NO CRANKING, NO SOUND FROM SOLENOID

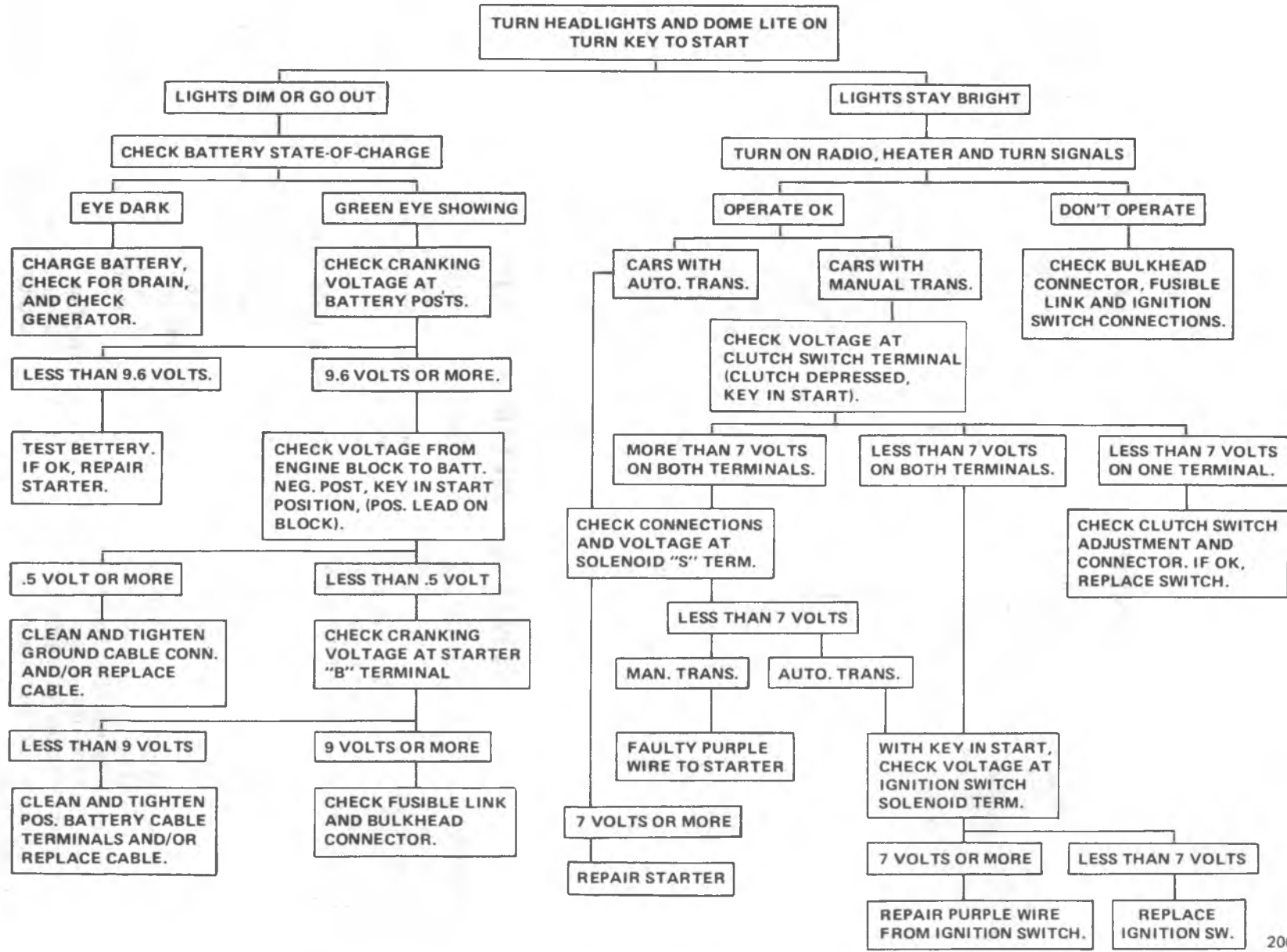

Fig. 6D-2--General Electrical System Diagnosis 2 of 2

206732

## BATTERY

|                               |      |                           |      |
|-------------------------------|------|---------------------------|------|
| General Description.....      | 6D-4 | Built In Hydrometer ..... | 6D-5 |
| General Information.....      | 6D-4 | Diagnosis.....            | 6D-5 |
| Common Causes of Failure..... | 6D-4 | On Car Service.....       | 6D-6 |
| Electrolyte Freezing .....    | 6D-4 | Charging Procedure .....  | 6D-6 |
| Carrier and Hold Down .....   | 6D-4 | Jump Starting.....        | 6D-7 |
| Visual Inspection .....       | 6D-5 | Remove and Replace.....   | 6D-7 |
| Ratings.....                  | 6D-5 |                           |      |

### GENERAL DESCRIPTION

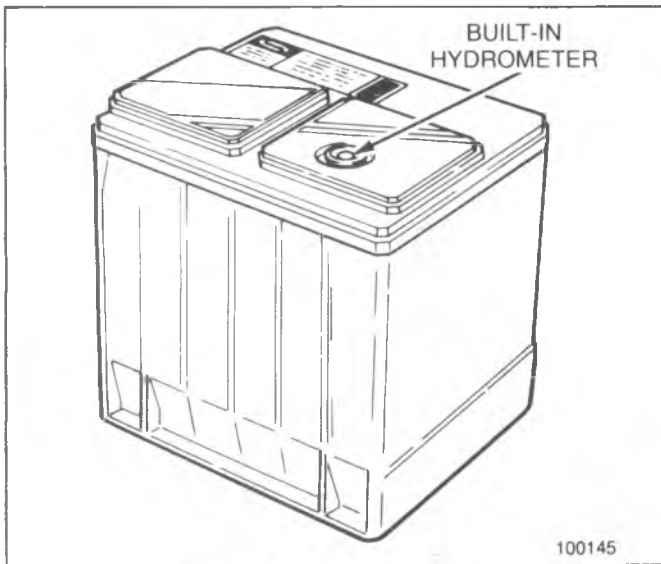

Fig. 6D-3--Sealed Top Battery

The sealed battery (see Fig. 6D-3) is standard on all

vehicles (see Specifications). There are no vent plugs in the cover. The battery is completely sealed, except for two small vent holes in the side. These vent holes allow the small amount of gas produced in the battery to escape. The battery has the following advantages over conventional batteries:

1. No water addition for the life of the battery.
2. Overcharge protection. If too high a level voltage is applied to the battery, it will not accept as much current as a conventional battery. In a conventional battery, the excess voltage will still try to charge the battery leading to gassing, which causes liquid loss.
3. Not as liable to self-discharge as compared to a conventional battery. This is particularly important when a battery is left standing for long periods of time.
4. More power available in a lighter and smaller case.

The battery has three major functions in the electrical system.

First, it is a source of electrical energy for cranking the engine. Second it acts as a voltage stabilizer for the electrical system. And third, it can, for a limited time, provide energy when the electrical load used exceeds the output of the generator.

### GENERAL INFORMATION

#### COMMON CAUSES OF FAILURE

The battery is not designed to last indefinitely; however, with proper care, it will provide many years of service. If the battery tests good but fails to perform satisfactorily in service for no apparent reason, the following are some of the more important factors that may point to the cause of trouble:

1. Accessories left on overnight .
2. Slow average driving speeds for short periods.
3. The vehicle electrical load is more than the generator output particularly with the addition of after market equipment.
4. Defects in the charging system such as electrical shorts, slipping fan belt, faulty generator or voltage regulator.
5. Battery abuse, including failure to keep the battery cable terminals clean and tight or loose battery hold down. See On-Vehicle Service for torque specifications.
6. Mechanical problems in the electrical system such as shorted or pinched wires.

#### Electrolyte Freezing

The freezing point of electrolyte depends on its specific gravity. Since freezing may ruin a battery, it should be protected against freezing by keeping it in charged condition.

#### Carrier and Hold-Down

The battery carrier and hold-down clamp should be clean and free from corrosion before installing the battery. The carrier should be in a sound condition so that it will support the battery securely and keep it level.

Make certain there are no parts in carrier before installing the battery.

To prevent the battery from shaking in its carrier, the hold-down bolts should be tight but not over tightened.

#### Visual Inspection

The external condition of the battery should be checked periodically for damage such as cracked cover or case.

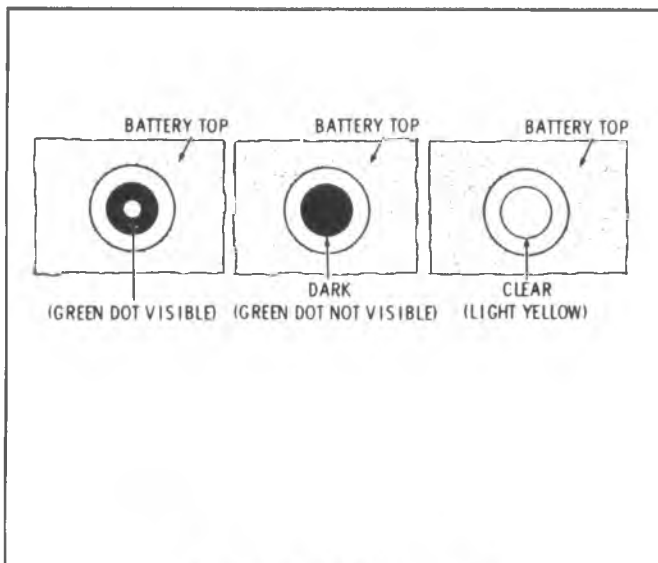

Fig. 6D-4--Built-In Hydrometer

## RATINGS

A battery has two ratings: (1) a reserve capacity rating at 27°C (80°F) which is the time a fully charged battery will operate the car with no generator operation, (2) a cold crank rating at -18°C (0°F) which indicates the cranking load capacity. (See Specifications for specific battery ratings).

## Built-In Hydrometer

The sealed battery has a built-in temperature compensated hydrometer in the top of the battery. This hydrometer is to be used with the following diagnostic procedure. When observing the hydrometer, make sure that the battery has a clean top. A light may be needed in some poorly-lit areas.

Under normal operation, two indications can be seen (see Figure 6D-4):

### 1. GREEN DOT VISIBLE

Any green appearance is interpreted as a "green dot" and the battery is ready for testing.

### 2. DARK; GREEN DOT NOT VISIBLE

If there is a cranking complaint, the battery should be tested as described in the Diagnosis section. The charging and electrical systems should also be checked at this time.

Occasionally, a third condition may appear:

### 3. CLEAR OR LIGHT YELLOW

This means the fluid level is below the bottom of the hydrometer. This may have been caused by excessive or prolonged charging, a broken case, excessive tipping or normal battery wearout. When finding a battery in this condition, it may indicate high charging voltage caused by a faulty charging system and therefore, the charging and electrical system may need to be checked. If a cranking complaint exists and is caused by the battery, it should be replaced.

## DIAGNOSIS

The following procedure should be used for testing batteries:

### 1. VISUAL INSPECTION

Check for obvious damage, such as cracked or broken case or cover, that could permit loss of electrolyte. If obvious damage is noted, replace the battery. Determine cause of damage and correct as needed. If not, proceed to step 2.

### 2. HYDROMETER CHECK (Fig. 6D-4)

#### a. GREEN DOT VISIBLE

- go to step 3.

#### b. DARK; GREEN DOT NOT VISIBLE.

Charge the battery as outlined under Charging Procedure section and proceed to Step 3.

### 3. LOAD TEST

Load testing may require use of battery side terminal adapters to insure good connections (see Fig. 6D-5). On diesel engine vehicles, disconnect and test each battery separately.

#### a. Connect a voltmeter and a battery load tester across the battery terminals.

#### b. Apply 300 ampere load for 15 seconds to remove surface charge from the battery. Remove load.

#### c. Wait 15 seconds to let battery recover and apply specified load from load test chart (See Specific Vehicle subsection). Read voltage after 15 seconds, then remove load.

#### d. If voltage does not drop below the minimum listed

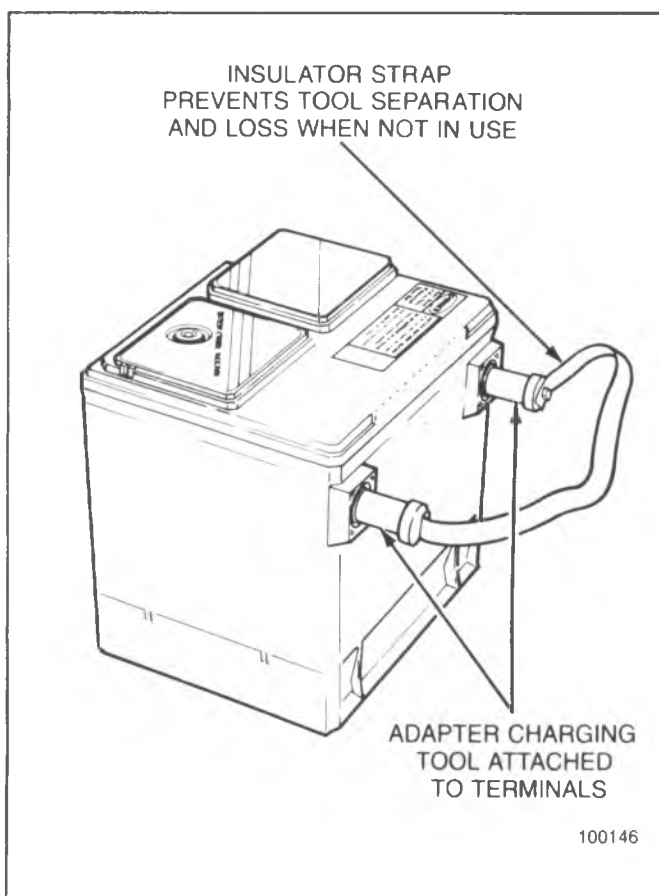

Fig. 6D-5--Side Terminal Battery Adapters

| Battery | Test Load (Amps) |
|---------|------------------|
| 1099    | 150              |
| 1103    | 200              |
| 1105    | 250              |
| 1106    | 270              |
| 1110    | 190              |

| <u>ESTIMATED TEMPERATURE</u> | <u>MINIMUM VOLTAGE</u> |
|------------------------------|------------------------|
| 70° F. (21° C.)              | 9.6                    |
| 50° F. (10° C.)              | 9.4                    |
| 30° F. (0° C.)               | 9.1                    |
| 15° F. (-10° C.)             | 8.8                    |
| 0° F. (-18° C.)              | 8.5                    |
| 0° F. (BELOW: -18° C.)       | 8.0                    |

6733

Fig. 6D-6--Temperature vs. Voltage Drop

returned to service. Temperature of the battery will change the minimum voltage to pass the load test. See Figure 6D-6 and estimate the temperature the battery has been exposed to for the last several hours.

in Fig. 6D-7, the battery is good and should be

## ON-CAR SERVICE

### BATTERY CHARGING

When it is necessary to charge the battery, the following safety precautions must be followed:

1. DO NOT CHARGE battery if hydrometer is clear or light yellow. Replace battery.
2. If the battery feels hot 52°C (125°F) or if violent gassing or spewing of electrolyte through the vent hole occurs, discontinue charging or reduce charging rate.

### CHARGING PROCEDURE

1. Batteries with green dot showing do not require charging unless they have just been discharged (such as in cranking vehicle).
2. When charging sealed-terminal batteries out of vehicle, install adapter kit ST-1201 or 1846855 or equivalent). (Refer to Figure 6D-5). Post-type batteries need no adapters.
3. Make sure all charger connections are clean and tight.
4. For best results, batteries should be charged while electrolyte and plates are at room temperature. A battery that is extremely cold may not accept current for several hours after starting charger.
5. Charge battery until green dot appears (See Charging Time Required). Battery should be checked every half-hour while charging. Tipping or shaking battery may be necessary to make green dot appear.
6. After charging, battery should be tested as outlined in BATTERY TESTING.

### Charging Time Required:

The time required to charge a battery will vary dependent upon the following factors:

- Size of Battery - A completely discharged large heavy-duty battery requires more than twice the recharging as a completely discharged small passenger car battery.

- Temperature - A longer time will be needed to charge any battery at 0°F than at 80°F. When a fast charger is connected to a cold battery, the current accepted by the battery will be very low at first, then in time the battery will accept a higher rate as the battery warms.
- Charger Capacity - A charger which can supply only five amperes will require a much longer period of charging than a charger that can supply 30 amperes or more.
- State-Of-Charge - A completely discharged battery requires more than twice as much charge as a one-half charged battery. Because the electrolyte is nearly pure water and a poor conductor in a completely discharged battery, the current accepted by the battery is very low at first. Later, as the charging current causes the electrolyte acid content to increase, the charging current will likewise increase.

### CHARGING A VERY FLAT OR COMPLETELY DISCHARGED BATTERY (OFF THE VEHICLE)

The following procedure should be used to recharge a very flat or completely discharged battery:

Unless the procedure is properly followed, a perfectly good battery may be needlessly replaced.

1. Measure voltage at battery terminals with an accurate voltmeter. If below 10 volts, then the charge current will be very low and it could take some time before it accepts a current in excess of a few milliamperes. Such low current may not be detectable on ammeters available in the field.
2. Set battery charger on high setting.
3. Some chargers feature polarity protection circuitry which prevents charging unless the charger leads are connected to the battery terminals correctly. A

completely discharged battery may not have enough voltage to activate this circuitry, even though leads are connected properly, making it appear that the battery will not accept charging current. Therefore, follow the specific charger manufacturer's instruction telling how to bypass or override the circuitry so that the charger will turn on and charge a low-voltage battery.

4. Battery chargers vary in the amount of voltage and current they provide. The time required for the battery to accept measurable charger current at various voltages may be as follows:

- **VOLTAGE**

- A. 16.0 or more -- Up to 4 hours
- B. 14.0 - 15.9 -- Up to 8 hours
- C. 13.9 or less -- Up to 16 hours

If the charge current is still not measurable at the end of the above charging times, the battery should be replaced.

If the charge current is measurable during the charging time, the battery is considered to be good and charging should be completed in the normal manner.

5. It is important to remember that a completely discharged battery must be recharged for a sufficient number of ampere hours (AH) to restore it to a useable state. As a general rule of thumb, using the reserve capacity rating (RC) (refer to specifications) of the battery as the number of ampere hours of charge which will usually bring the green dot into view. For example, if battery is rated at 75 RC minutes, it would be completely recharged as follows:

- 10 ampere charge x 7-1/2 hours .....75 AH or
- 25 ampere charge x 3 hours .....75 AH, etc.

6. It is recommended that any battery recharged by this procedure be **LOAD TESTED** to establish serviceability.

### **JUMP STARTING IN CASE OF EMERGENCY WITH AUXILIARY (BOOSTER) BATTERY**

**NOTICE:** Do not push or tow the vehicle to start. Damage to the emission system and/or to other parts of the vehicle may result.

**NOTICE:** Both booster and discharged battery should be treated carefully when using jumper cables. Follow the procedure outlined below, being careful not to cause sparks:

**CAUTION:** Departure from these conditions or the procedure below could result in: (1) Serious personal injury (particularly to eyes) or property damage from such causes as battery explosion, battery acid, or electrical burns; and/or (2) damage to electronic components of either vehicle.

**CAUTION:** Never expose battery to open flame or electric spark-batteries generate a gas which is flammable and explosive.

**CAUTION:** Remove rings, watches, and other jewelry. Wear approved eye protection.

**CAUTION:** Do not allow battery fluid to contact eyes, skin, fabrics, or painted surfaces - fluid is a corrosive acid. Flush any contacted area with water immediately and thoroughly. Be careful that metal tools or jumper cables do not contact the positive battery terminal (or metal in contact with it) and any other metal on the car, because a short circuit could occur. Batteries should always be kept out of the reach of children.

1. Set parking brake and place automatic transmission in "PARK" (NEUTRAL for manual transmission.) Turn off the ignition, turn off lights and all other electrical loads.

2. Check the built-in hydrometer. If it is clear or light yellow, replace the battery.

**NOTICE:** When jump starting a diesel engine vehicle with charging equipment, be sure equipment used is 12-volt and negative ground. Do not use 24-volt charging equipment. Using such equipment can cause serious damage to the electrical system or electronic parts.

3. Attach the end of one jumper cable to the positive terminal of the booster battery and the other end of the same cable to the positive terminal of the discharged battery. Do not permit vehicles to touch each other as this could cause a ground connection and counteract the benefits of this procedure. (Use 12-volt battery only to jump start the engine).

4. Attach one end of the remaining negative cable to the negative terminal of the booster battery, and the other end to a solid engine ground (such as A/C compressor bracket or generator mounting bracket) at least 18 inches from the battery of the vehicle being started (DO NOT CONNECT DIRECTLY TO THE NEGATIVE TERMINAL OF THE DEAD BATTERY).

5. Start the engine of the vehicle that is providing the jump start and turn off electrical accessories. Then start the engine in the car with the discharged battery.

6. Reverse these directions exactly when removing the jumper cables. The negative cable must be disconnected from the engine that was jump started first.

### **Remove and Install**

1. Disconnect negative cable.
2. Disconnect positive cable.
3. Remove retainer screw and retainer.
4. Remove battery.
5. To install, reverse removal procedure.
6. Torque battery cables to 12 N·m (19 lb. ft.).

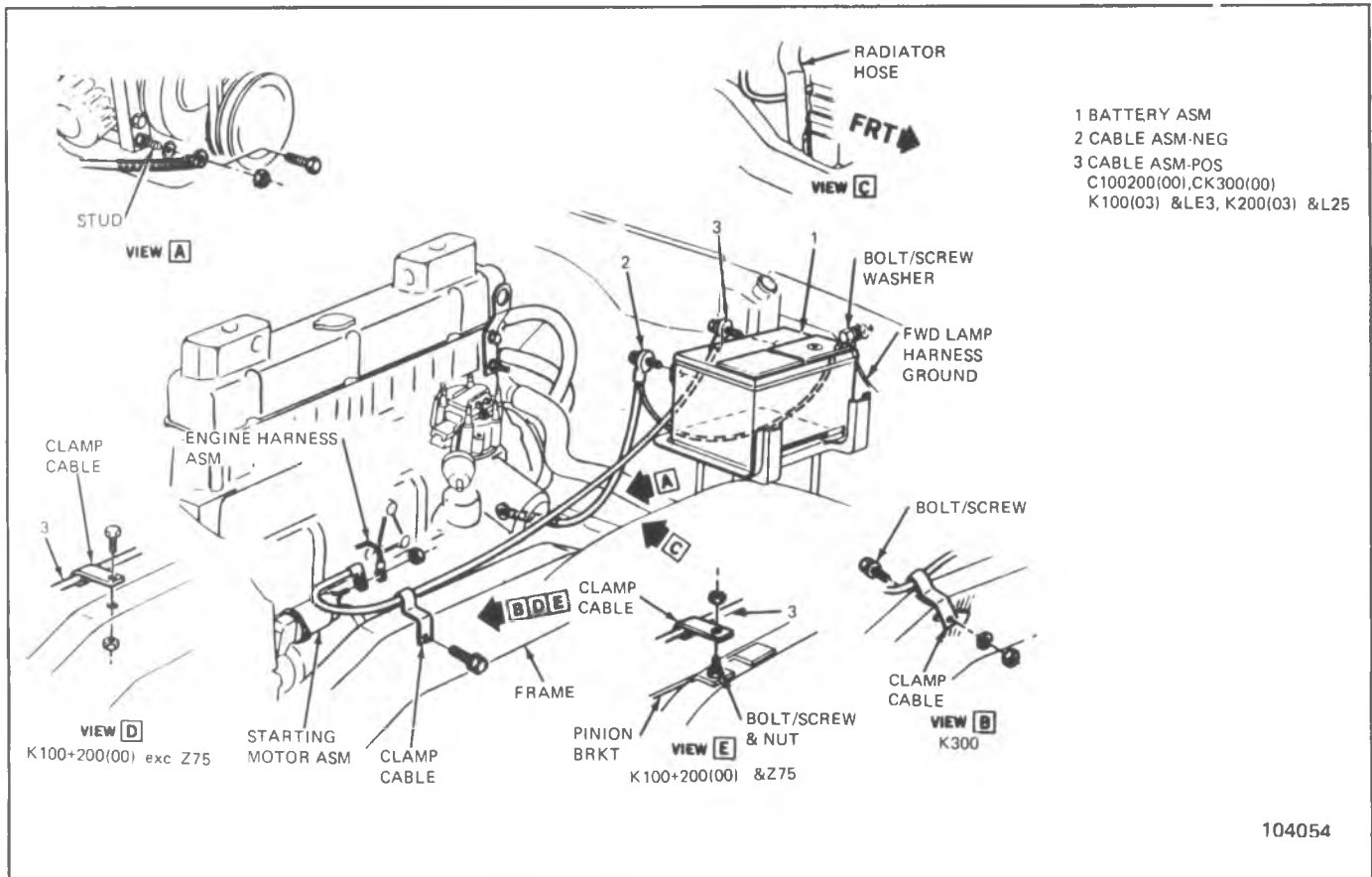

104054

Fig. 6D-8--Battery Cables CK LE2/125

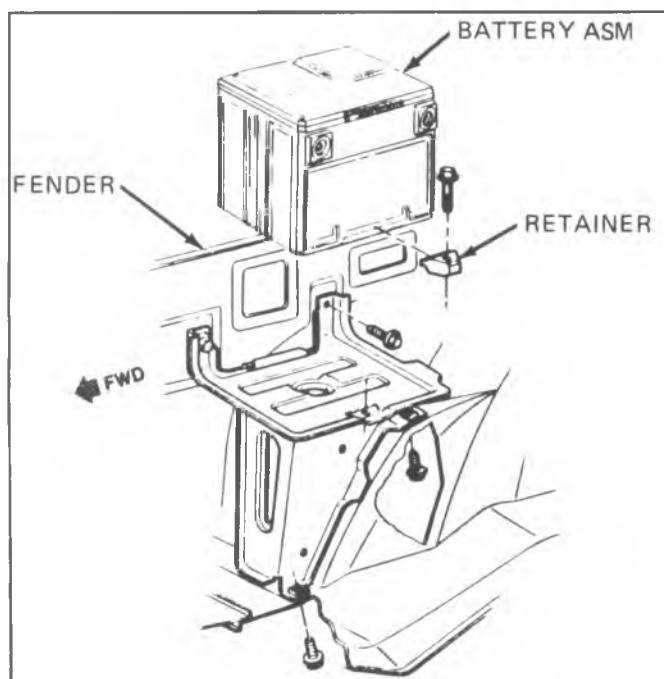

Fig. 6D-7--Battery Mounting-CK Truck

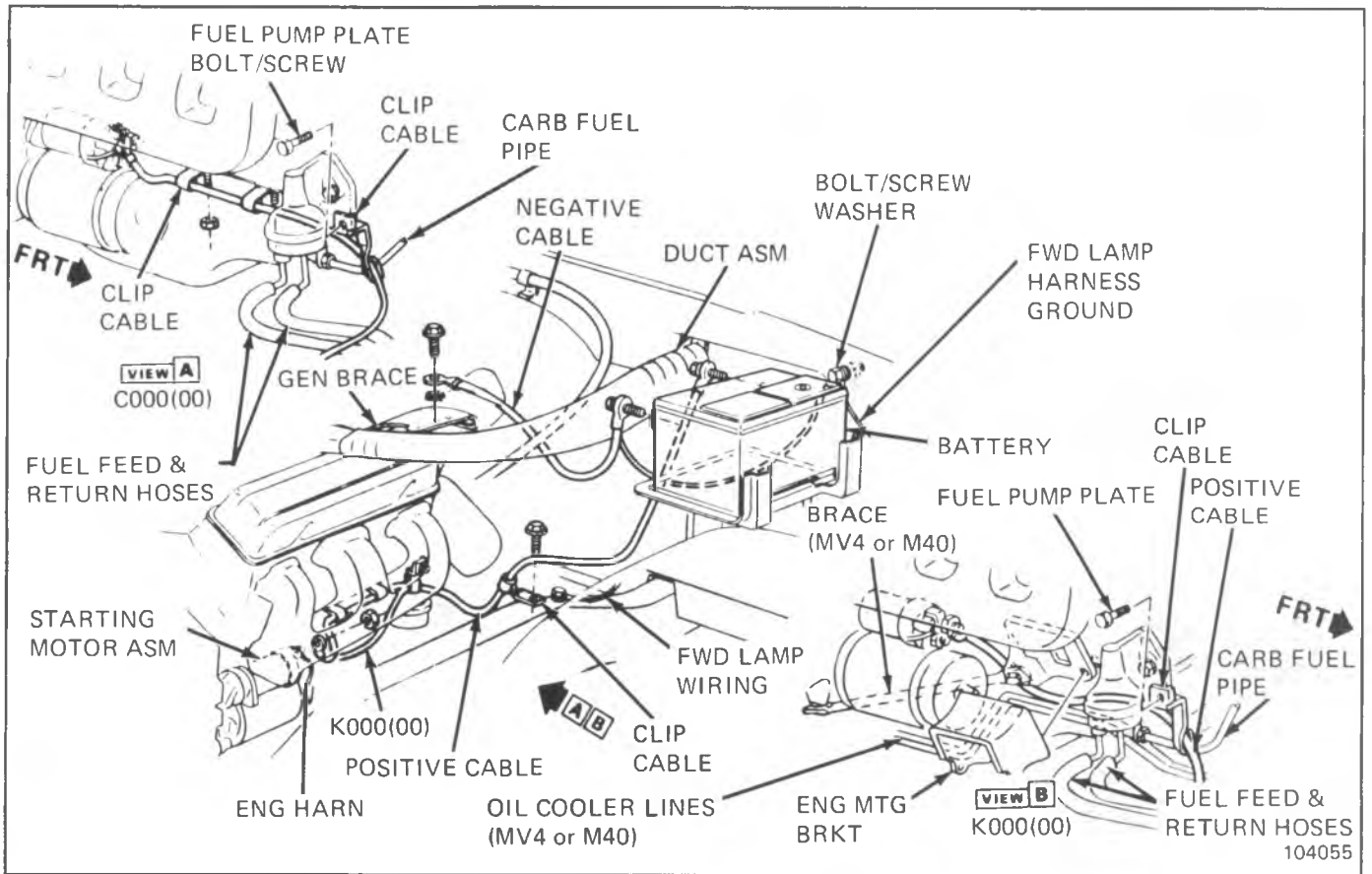

Fig. 6D-9--Battery Cables CK LE9/LF3/LF5/LS9/LT9

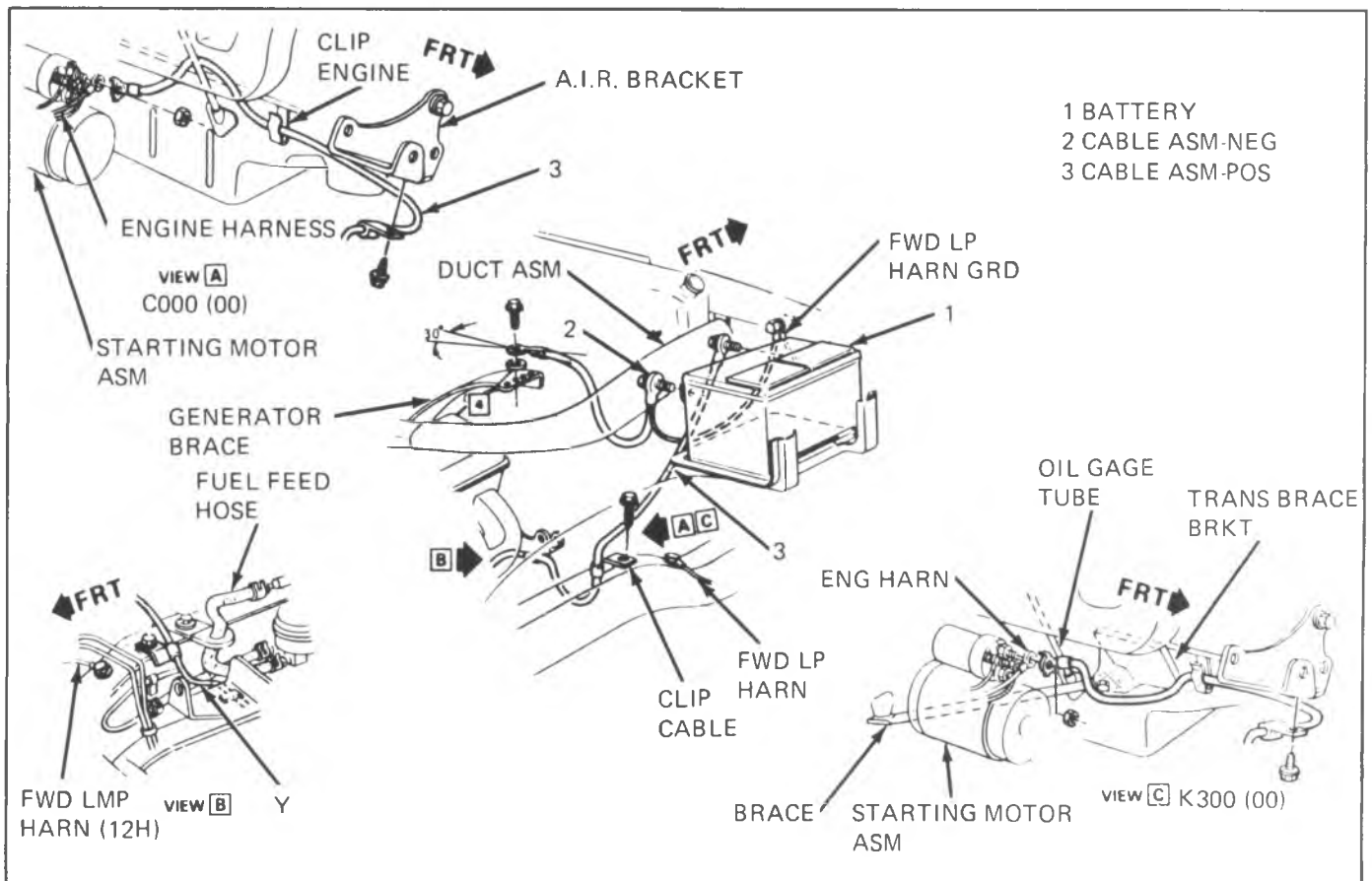

Fig. 6D-10--Battery Cables CK LE8



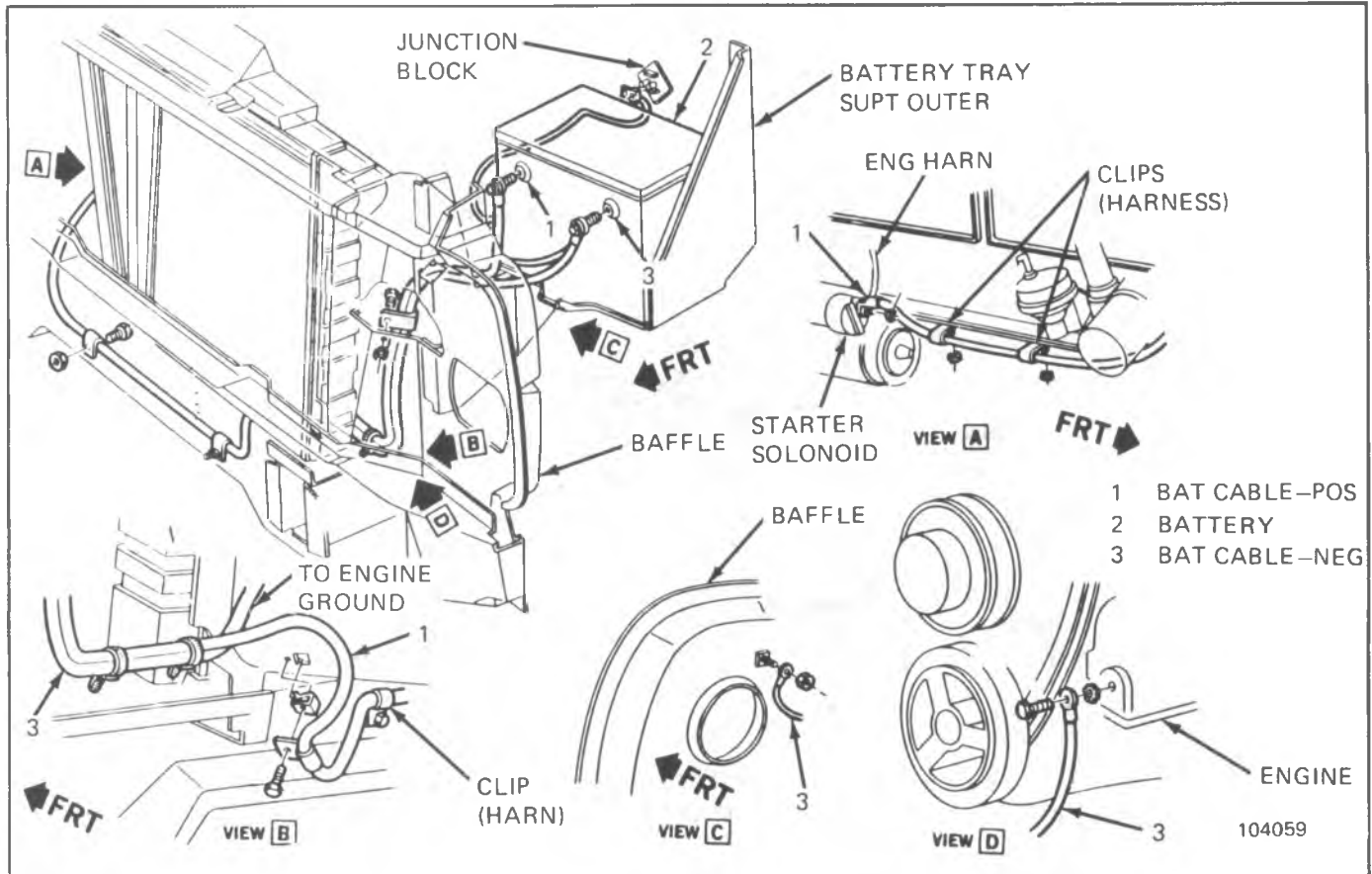

Fig. 6D-11--Battery Cables G-LE3

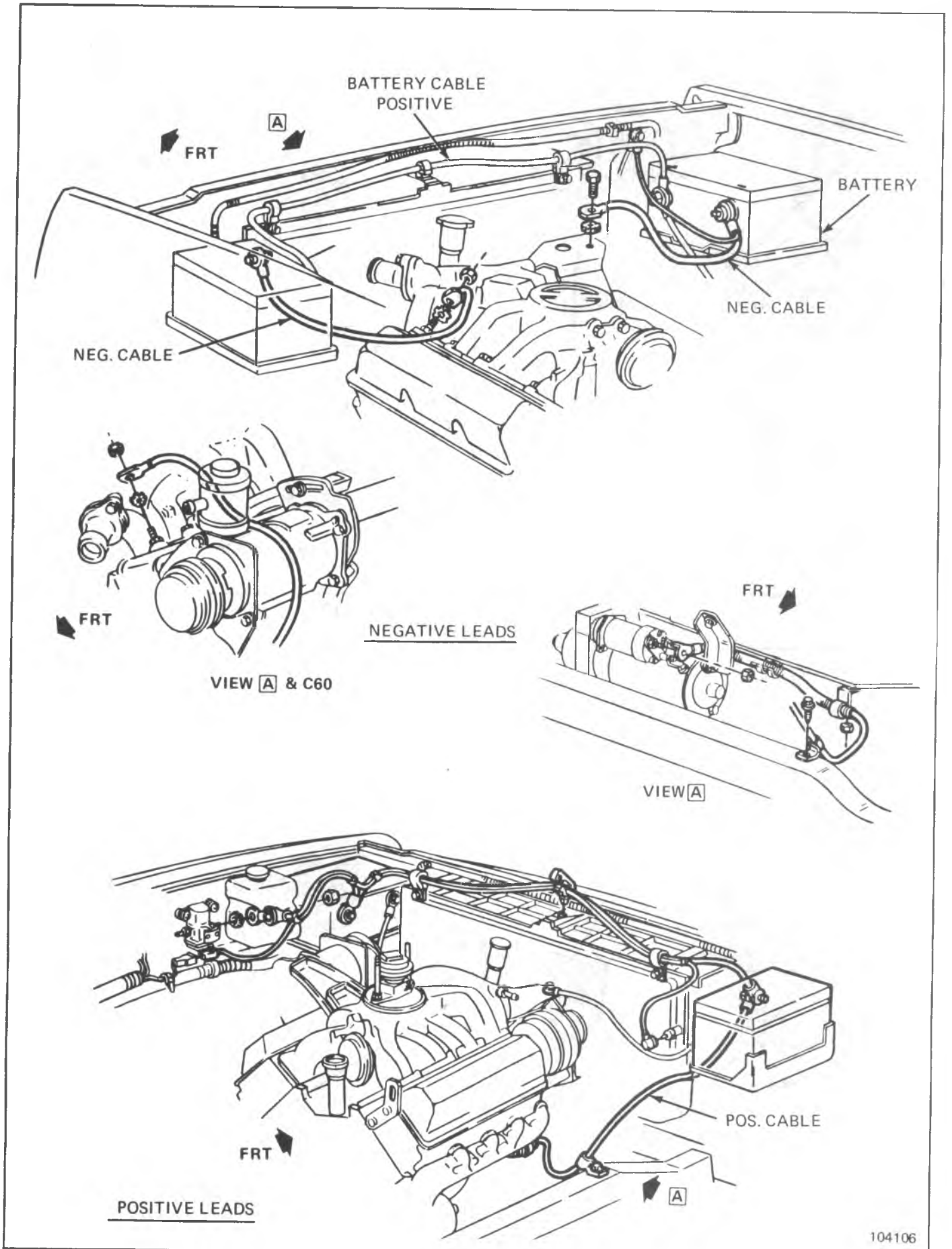

Fig. 6D-12--Battery Cables CK-Diesel Engine

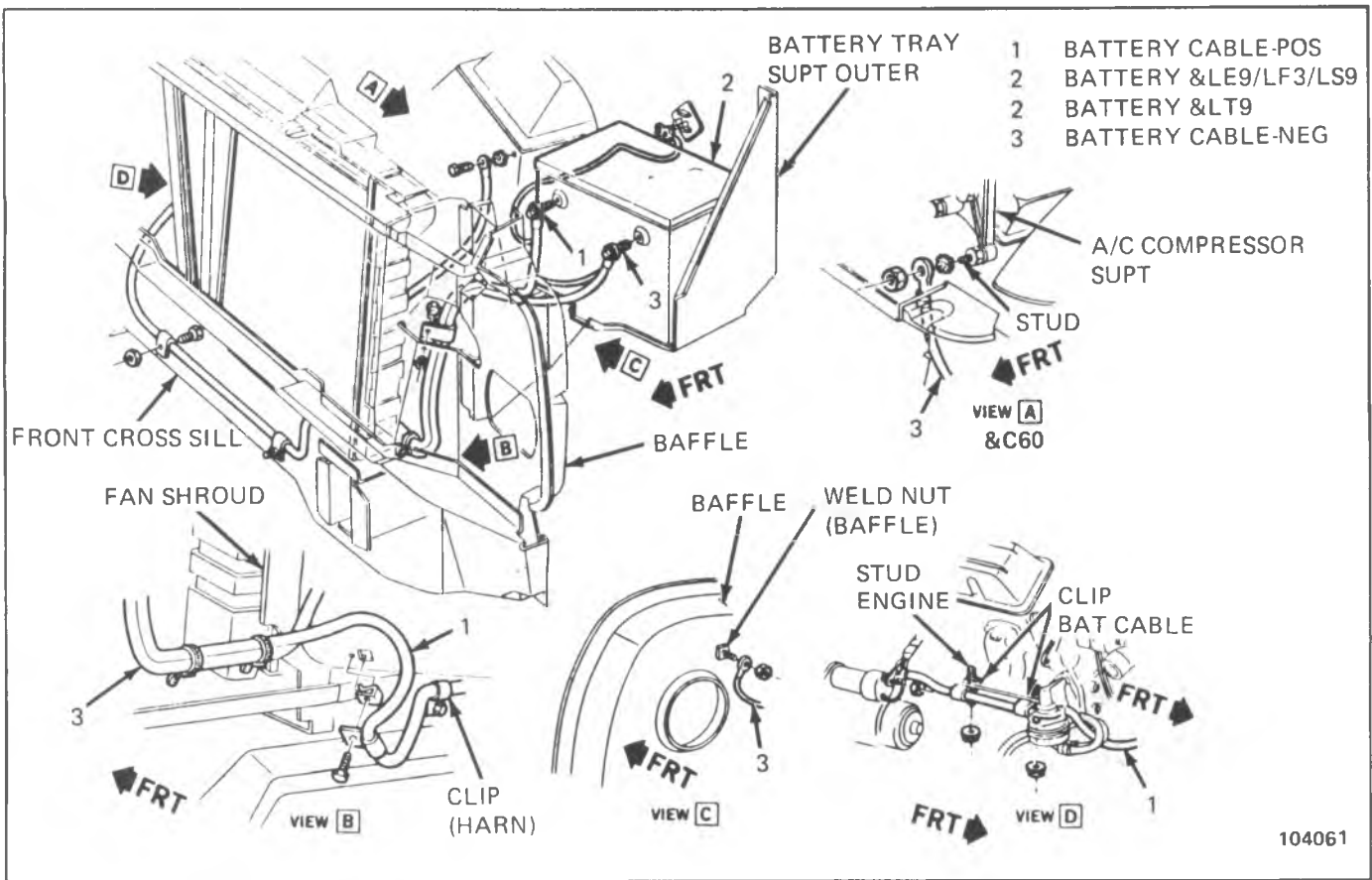

Fig. 6D-13--Battery Cables G-LE9/LF3/LS9/LT9

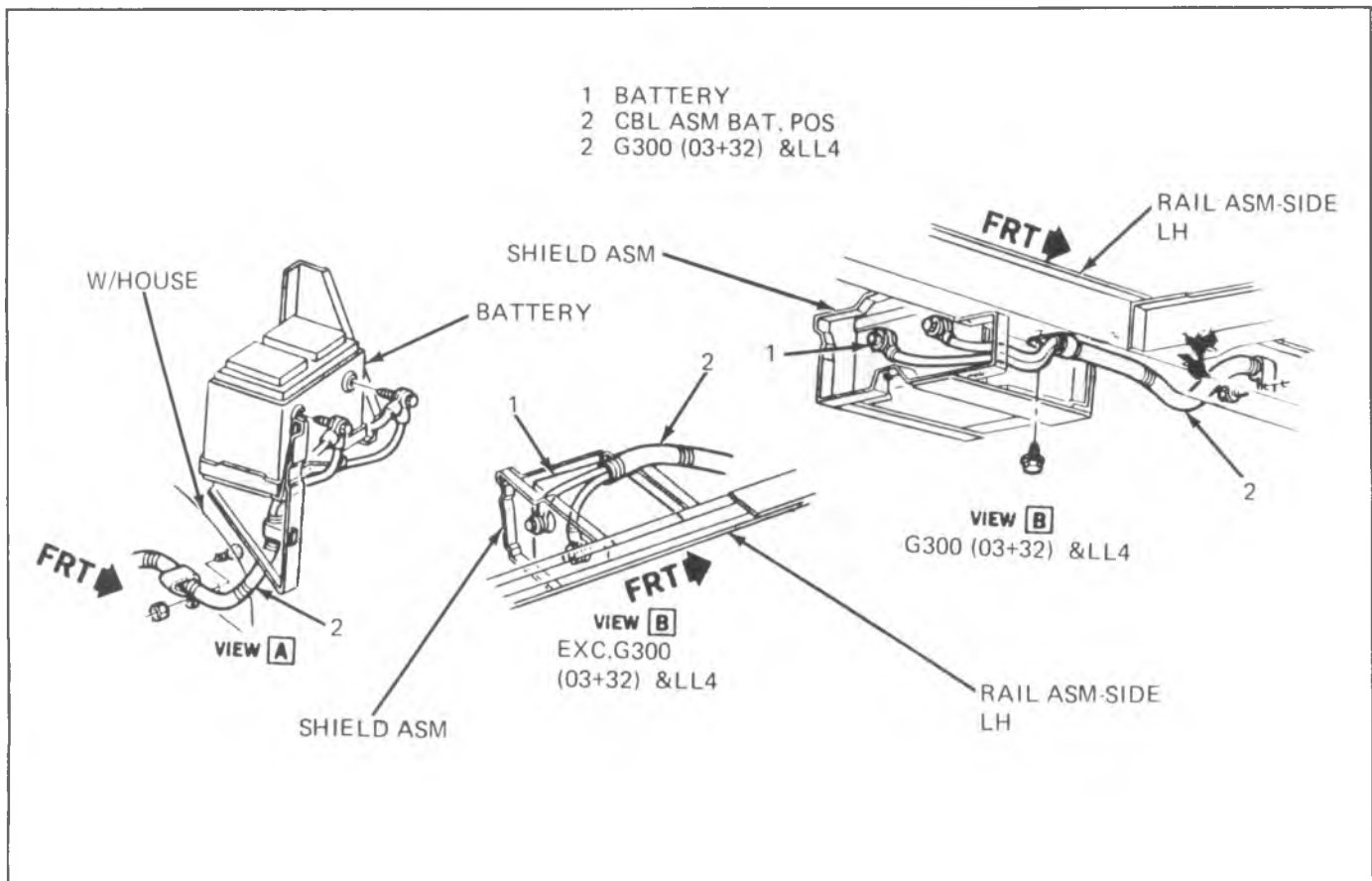

Fig. 6D-14--Battery Cables-G Diesel

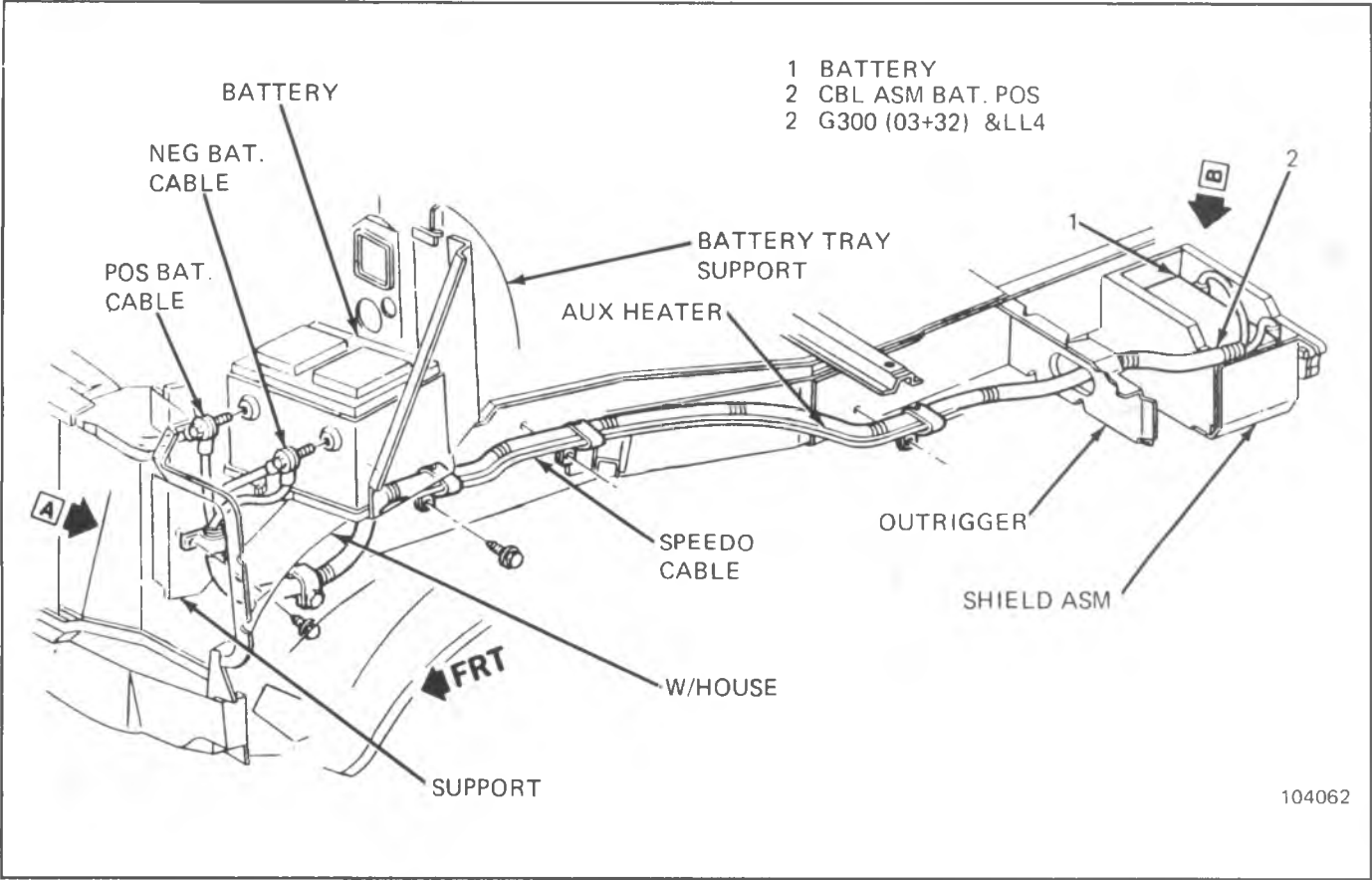

Fig. 6D-15--Battery Cables-G Diesel

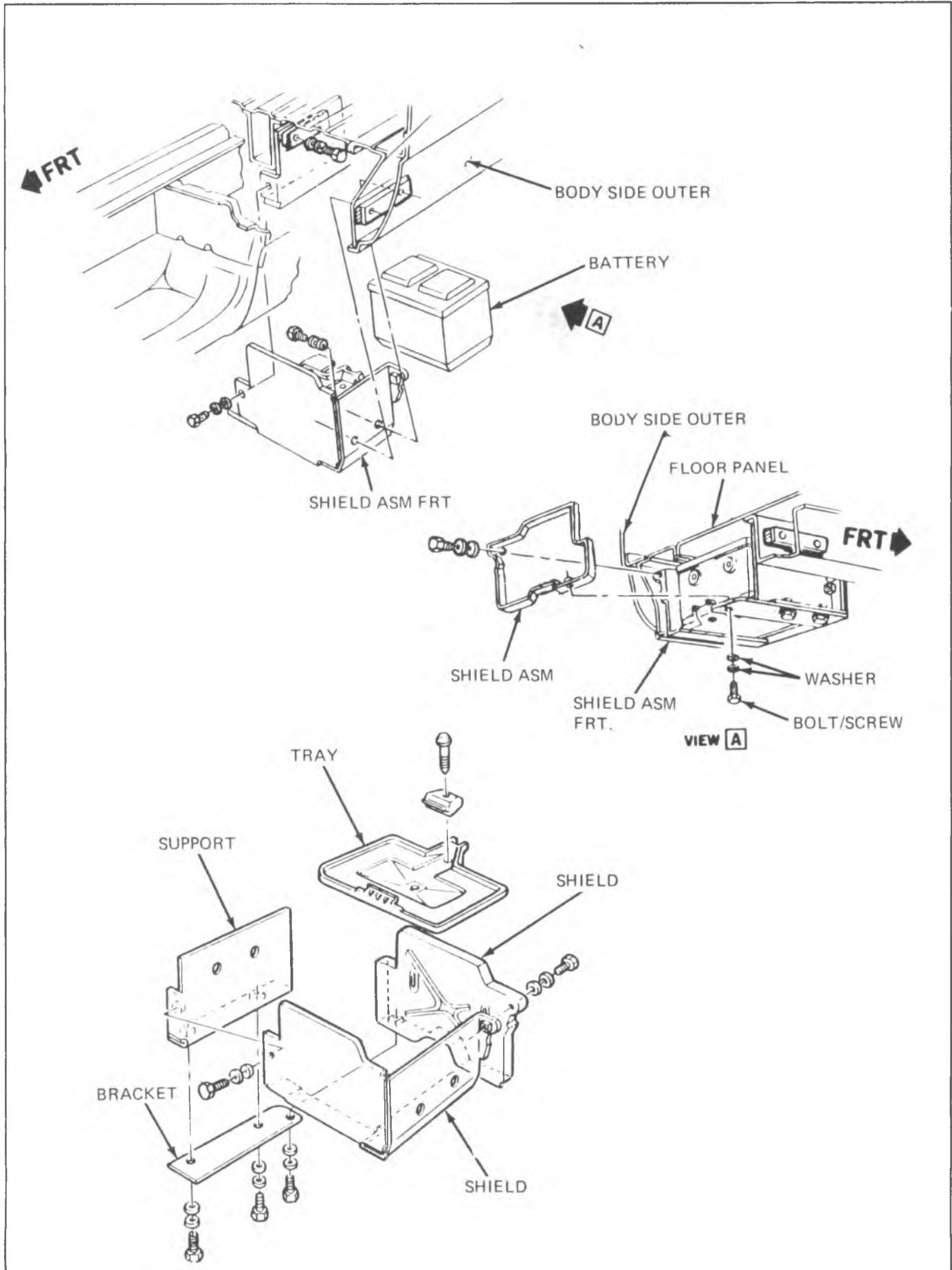

Fig. 6D-16-Battery Mounting G

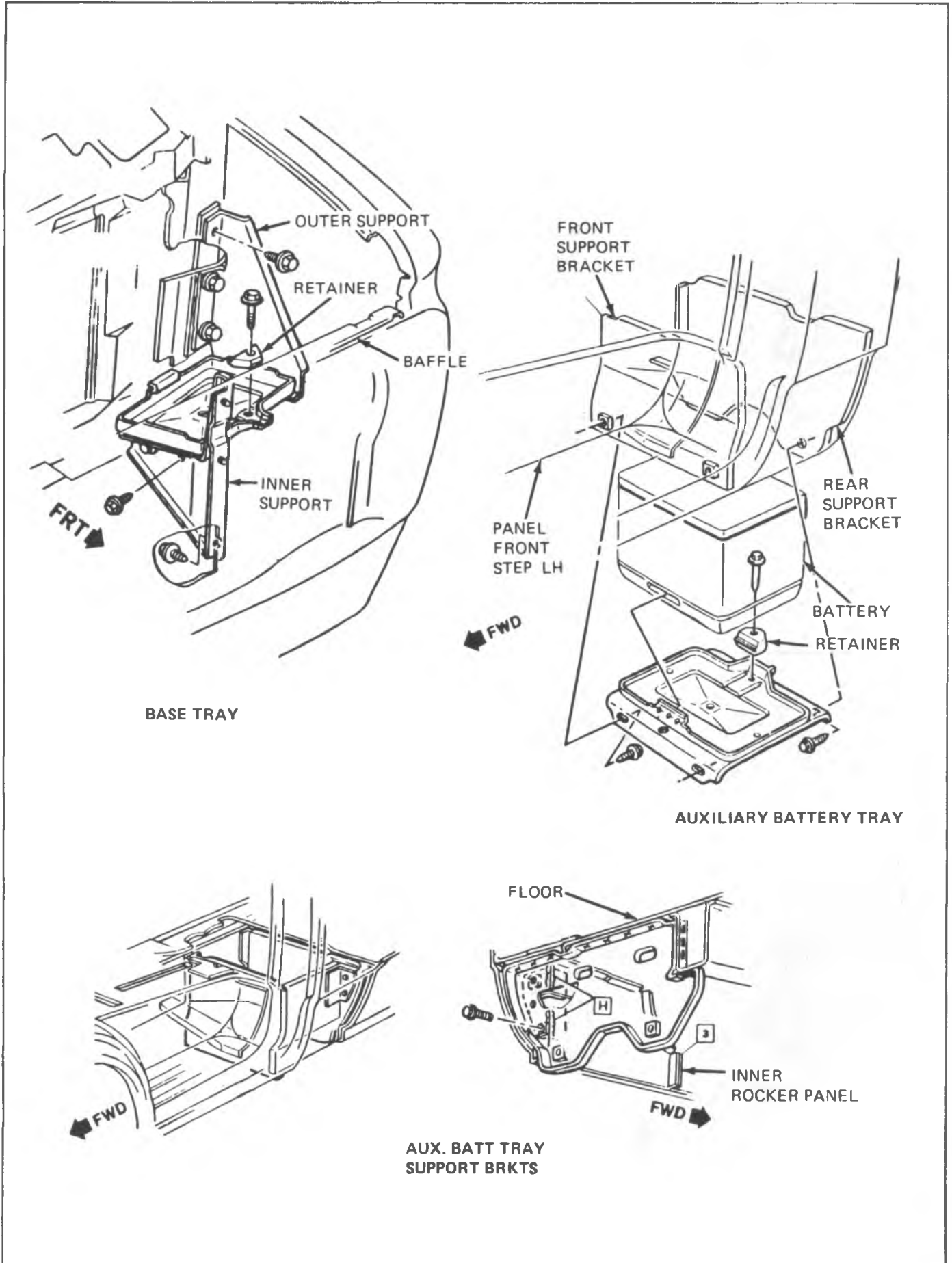

Fig. 6D-17--Battery Tray Mounting G

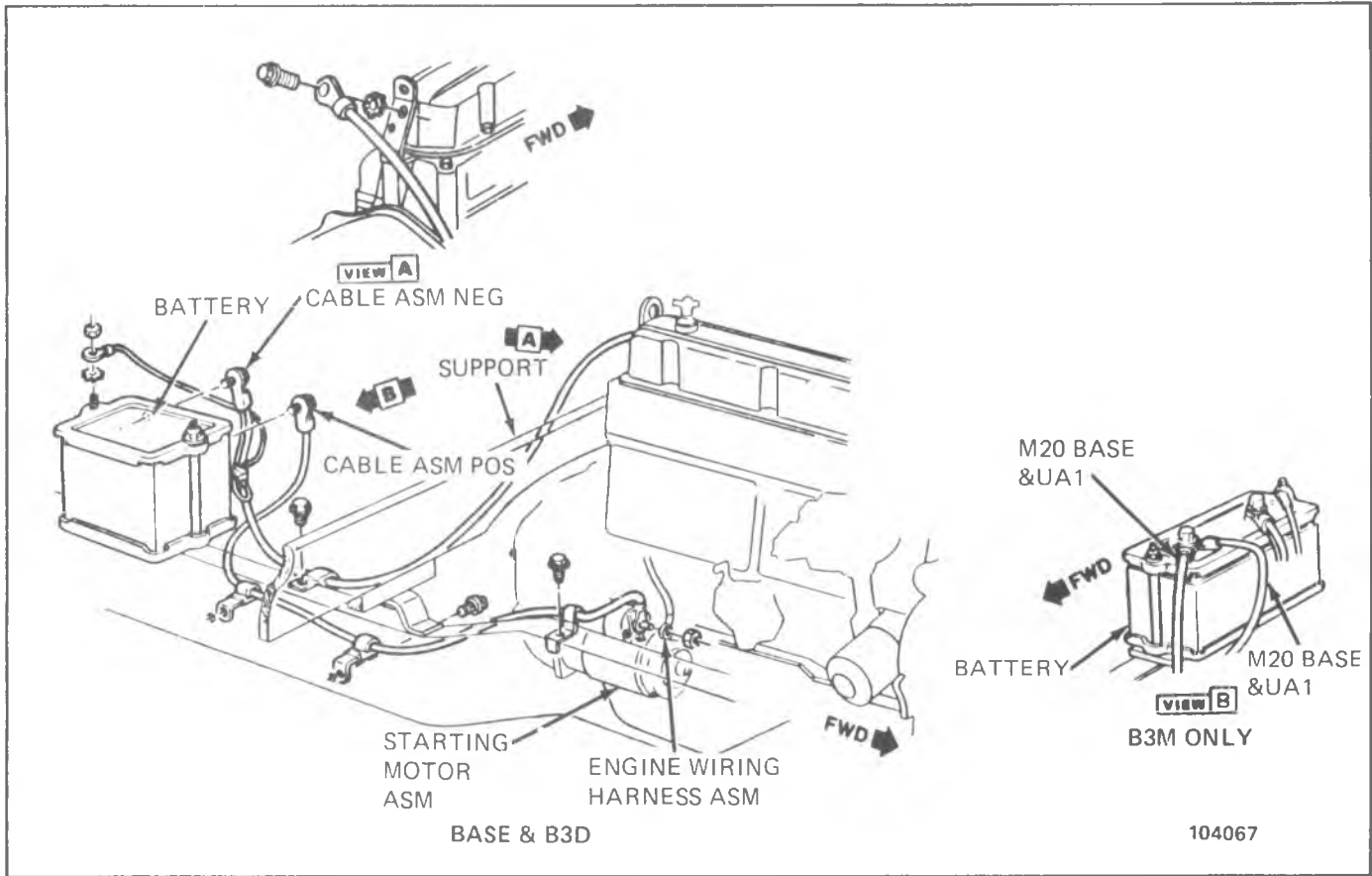

Fig. 6D-18--Battery Cables-P Series-L25, Exc E32, E33

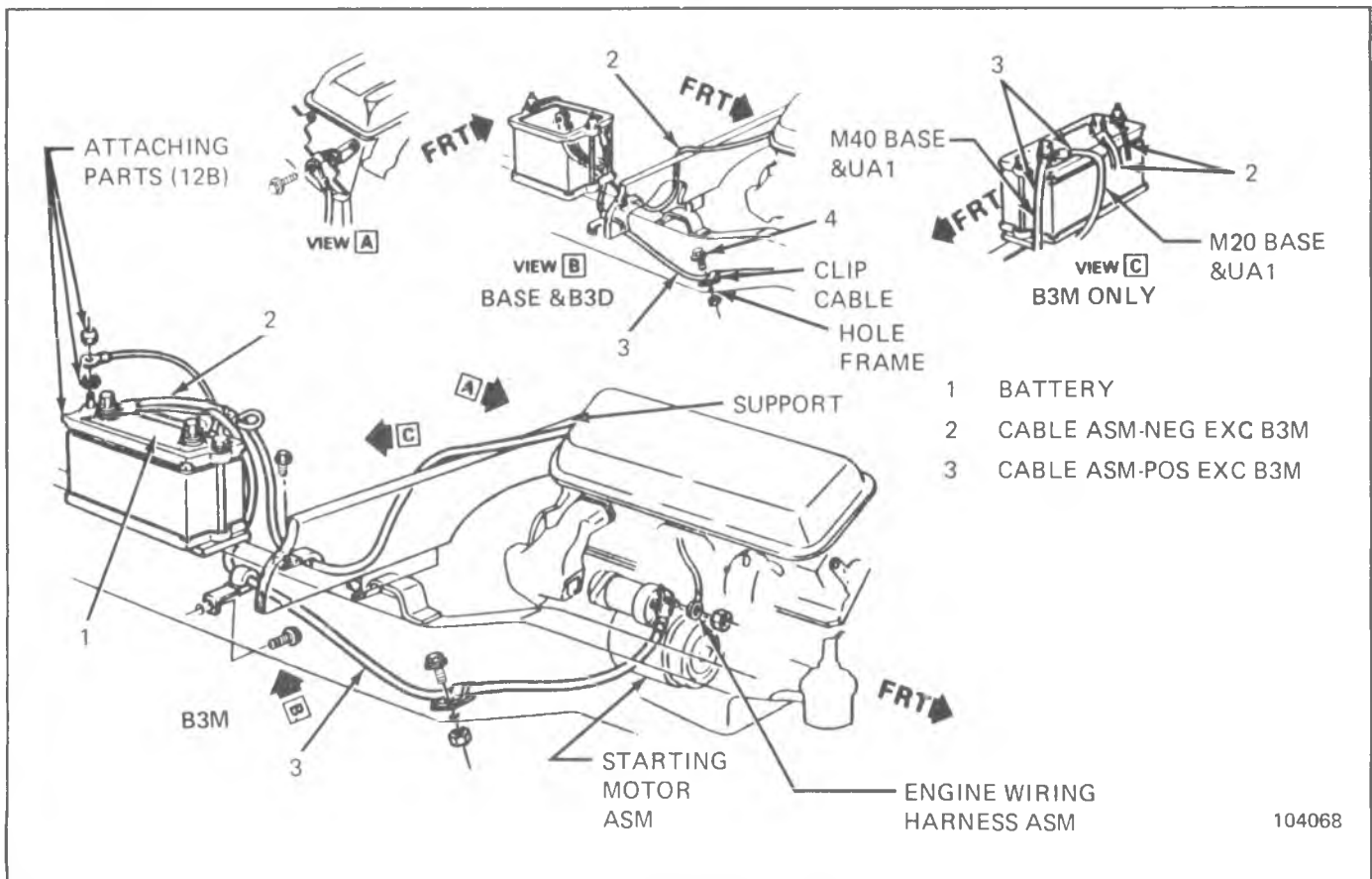

Fig. 6D-19--Battery Cables-P42-LE8, LT9, Exc E32, E33

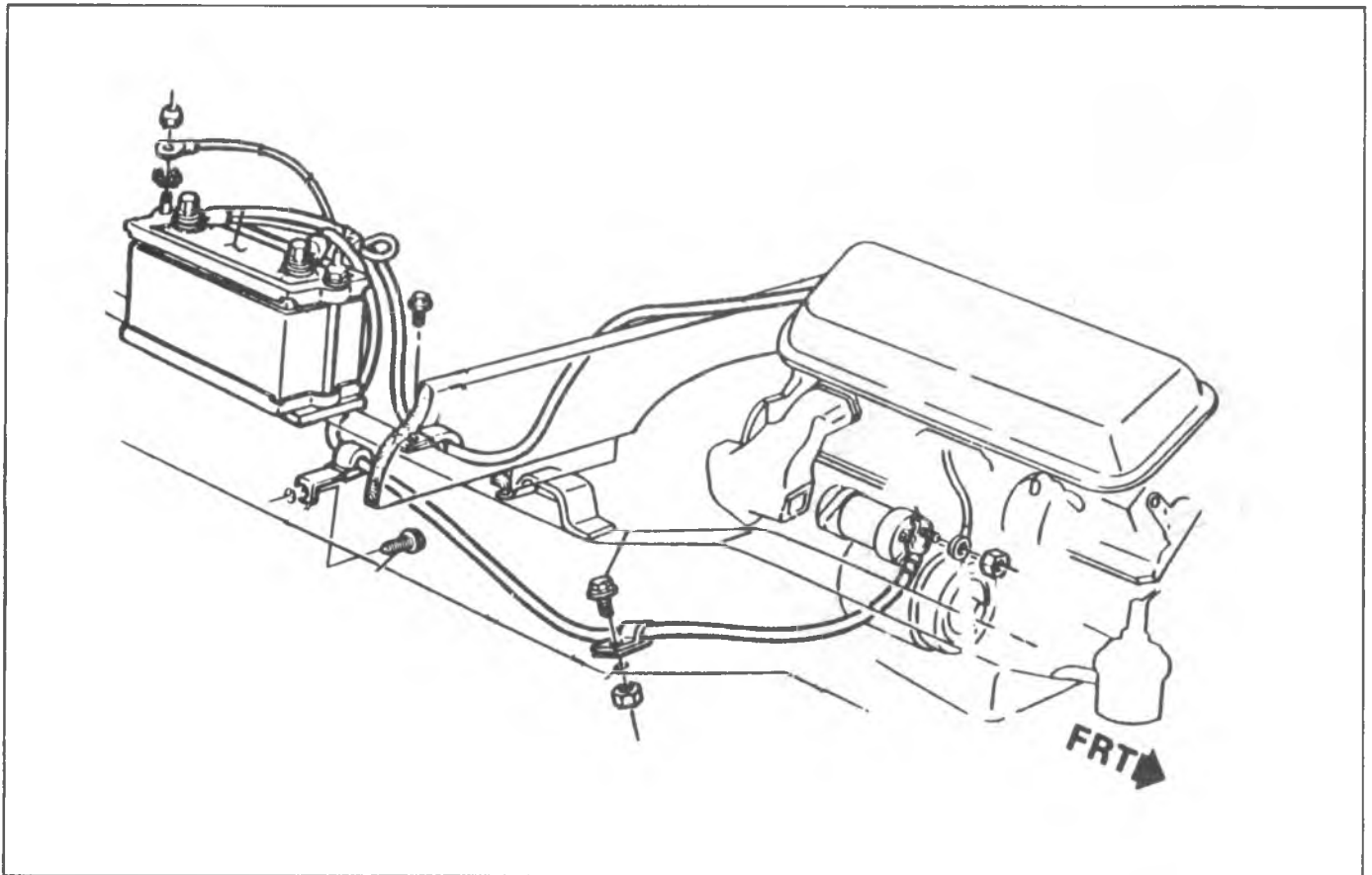

Fig. 6D-20--Battery Cables-P42-LE8, LT9 Exc E32, E33

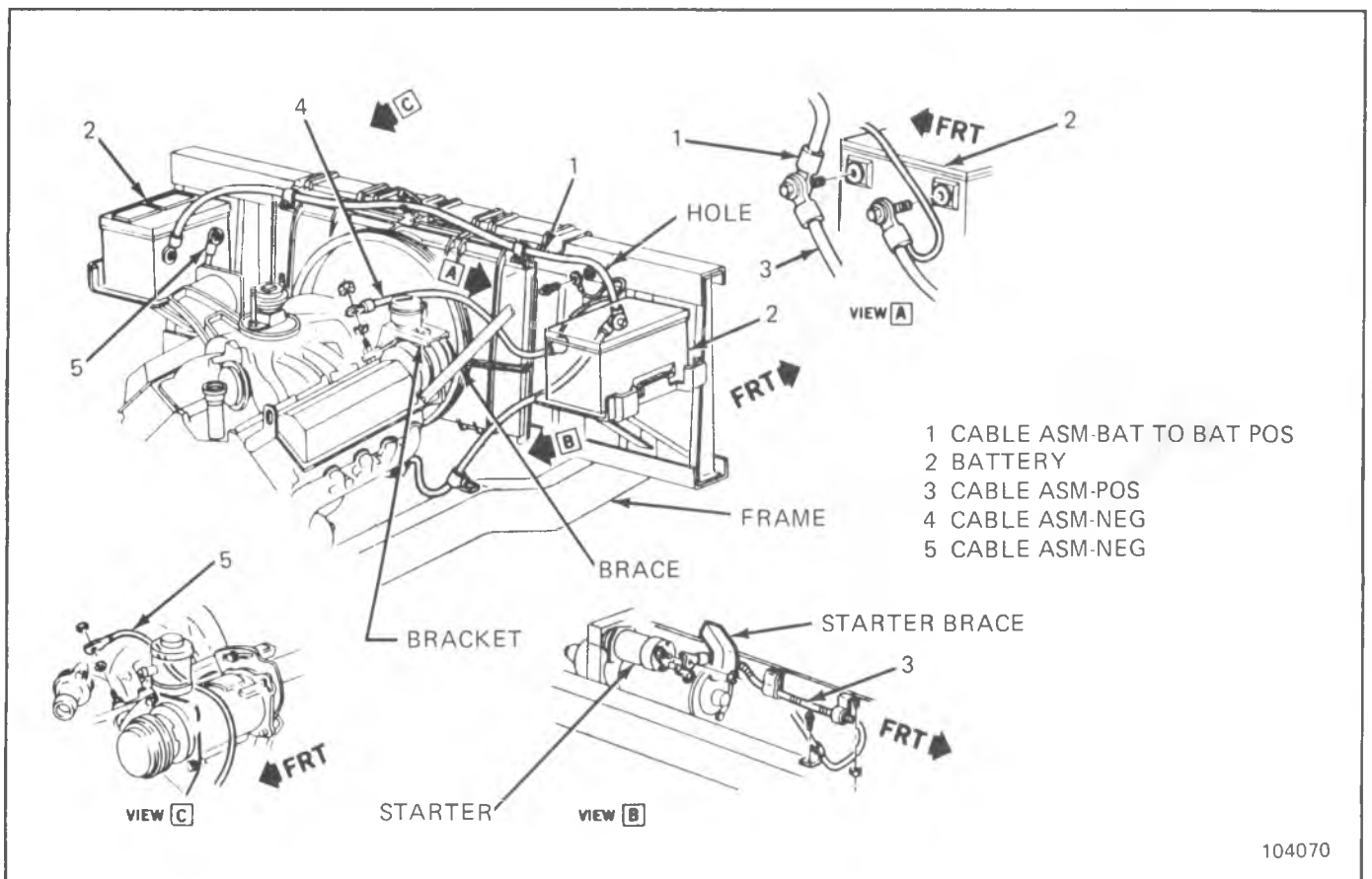

Fig. 6D-21--Battery Cables-P42-LL4 and E32/E33



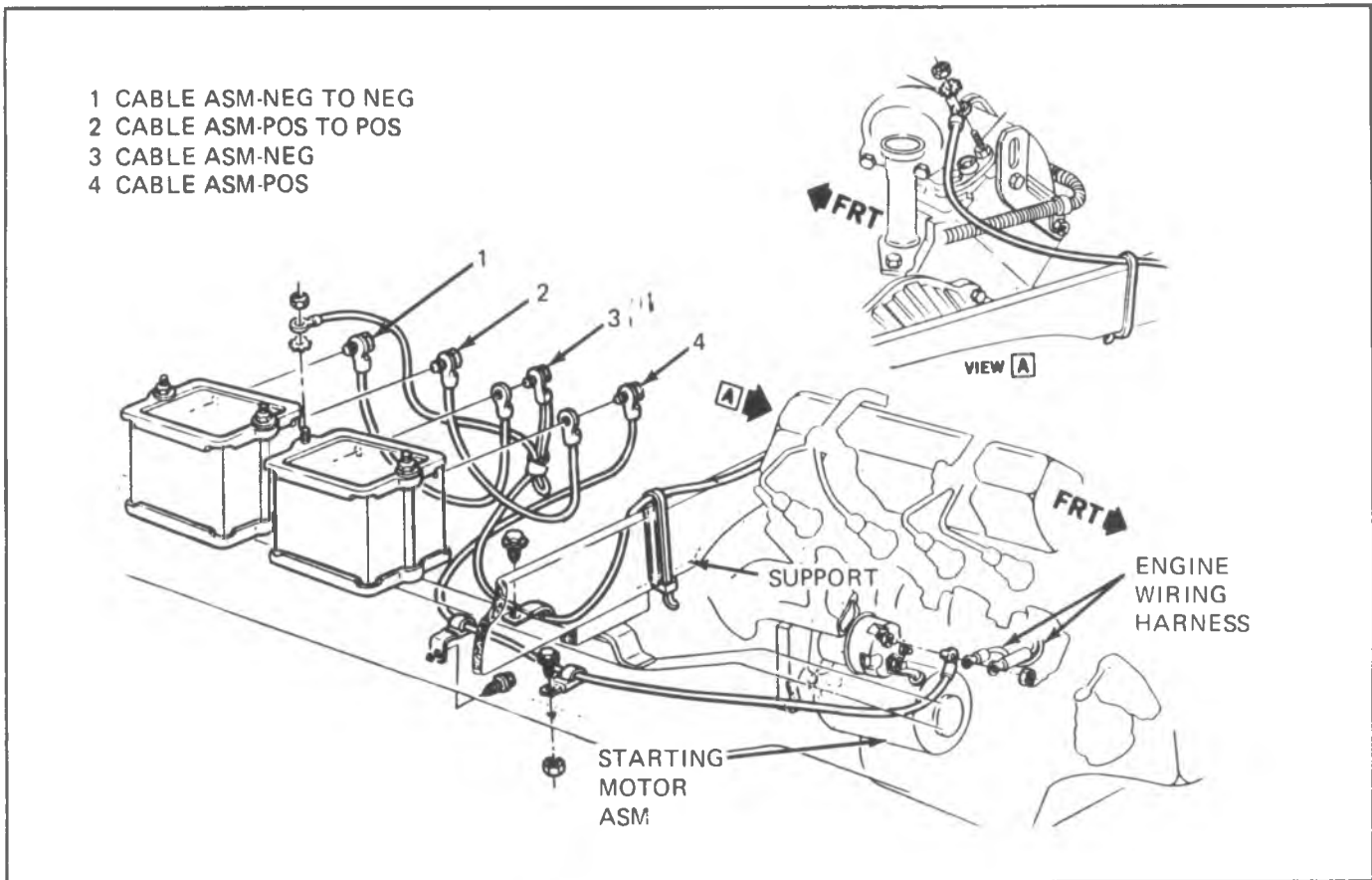

Fig. 6D-22--Battery Cables-P300-42 LL4 Exc. E32/E33

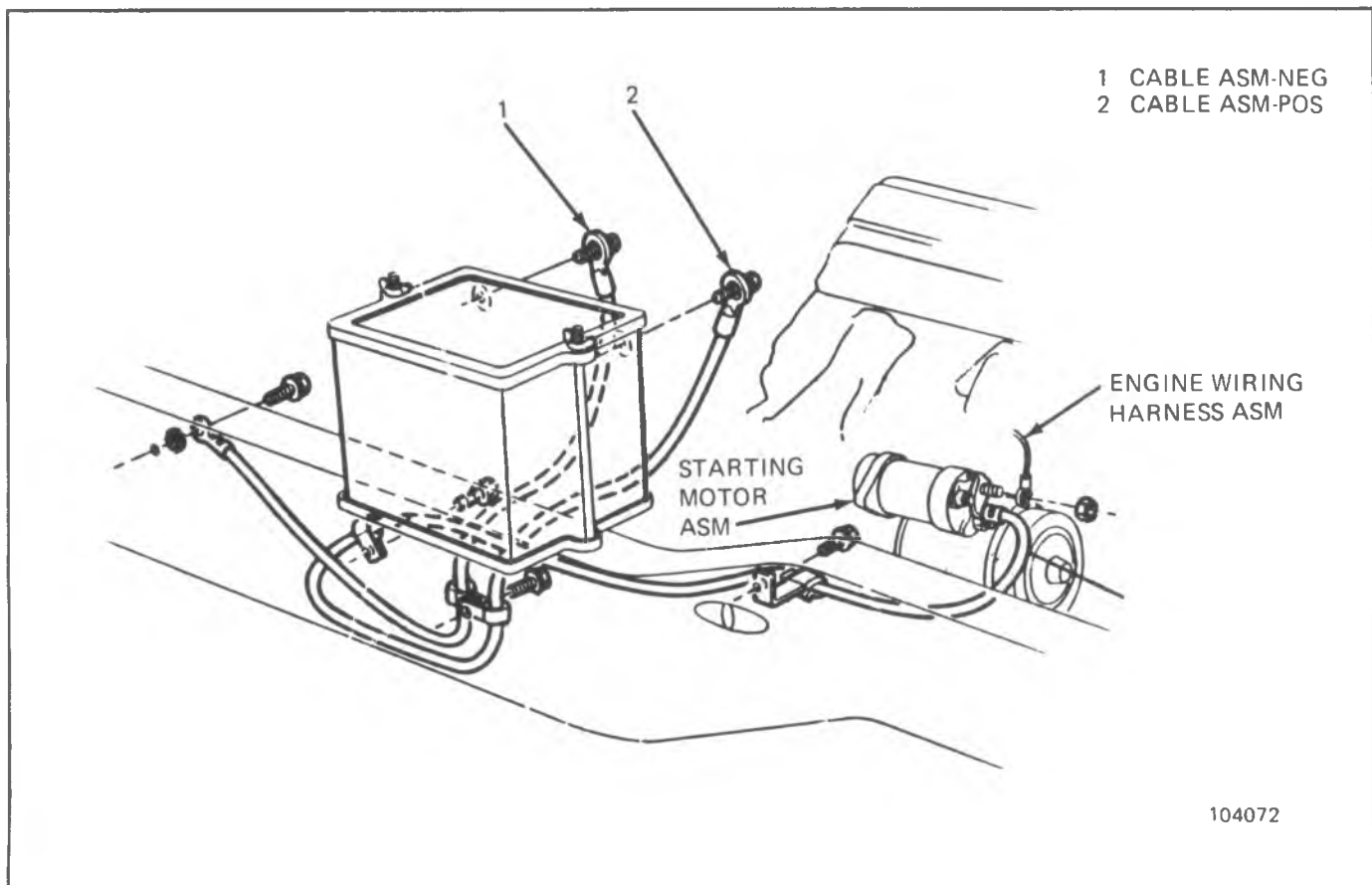

Fig. 6D-23--Battery Cables-P-LT9/LE8 and E32/E33

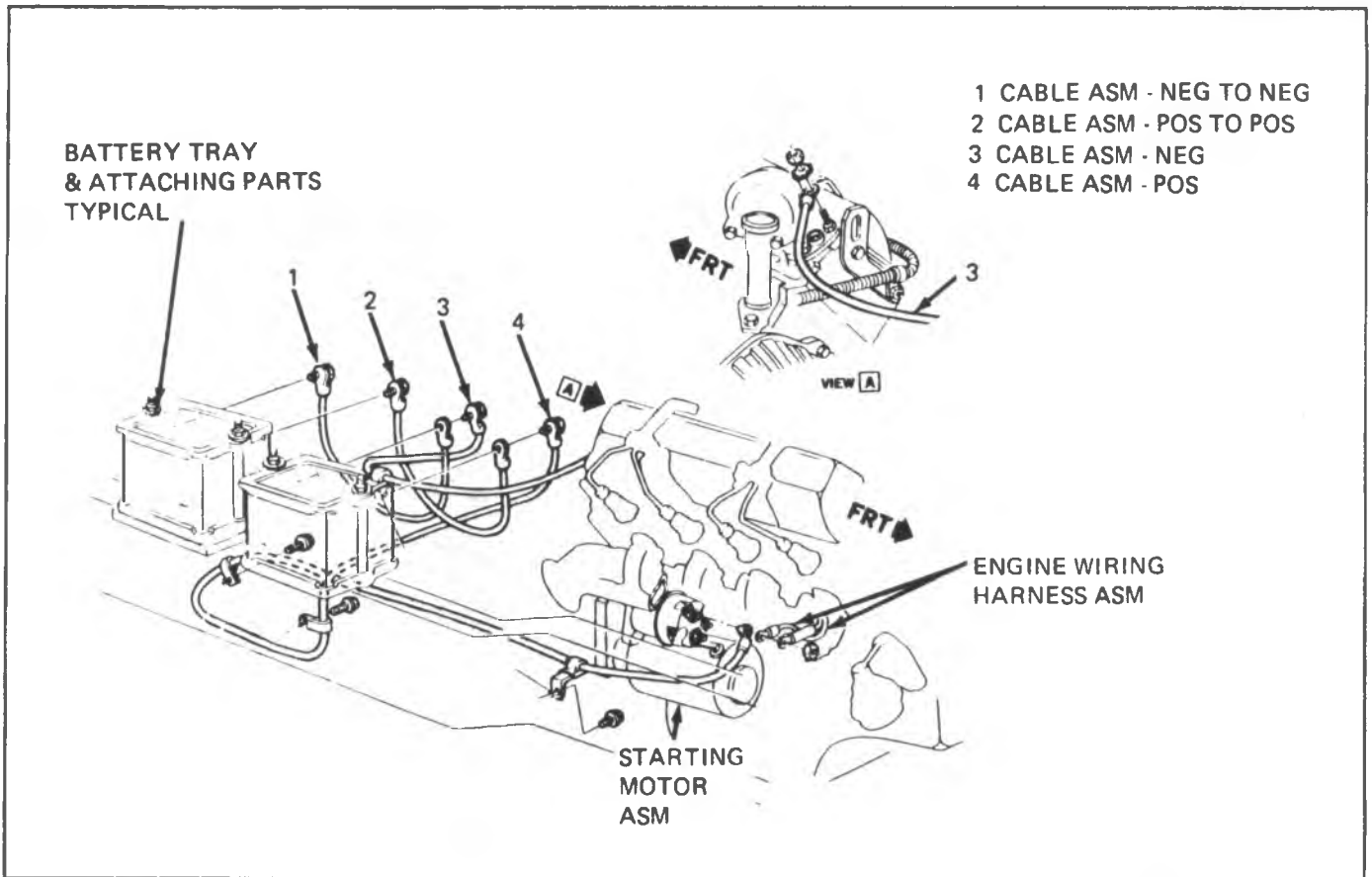

Fig. 6D-24--Battery Cables-P32, LT9/LE8 Exc. E32, E33

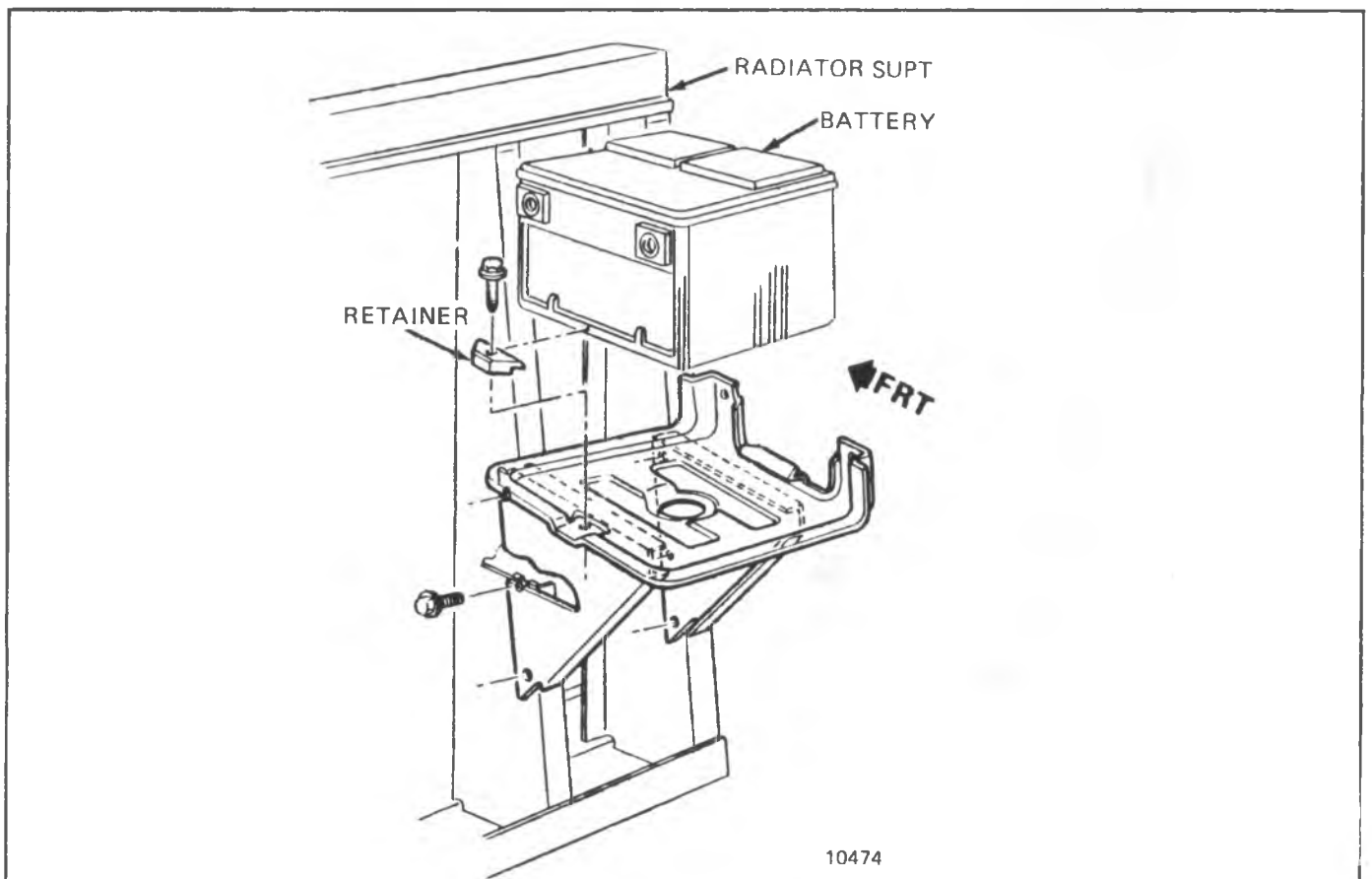
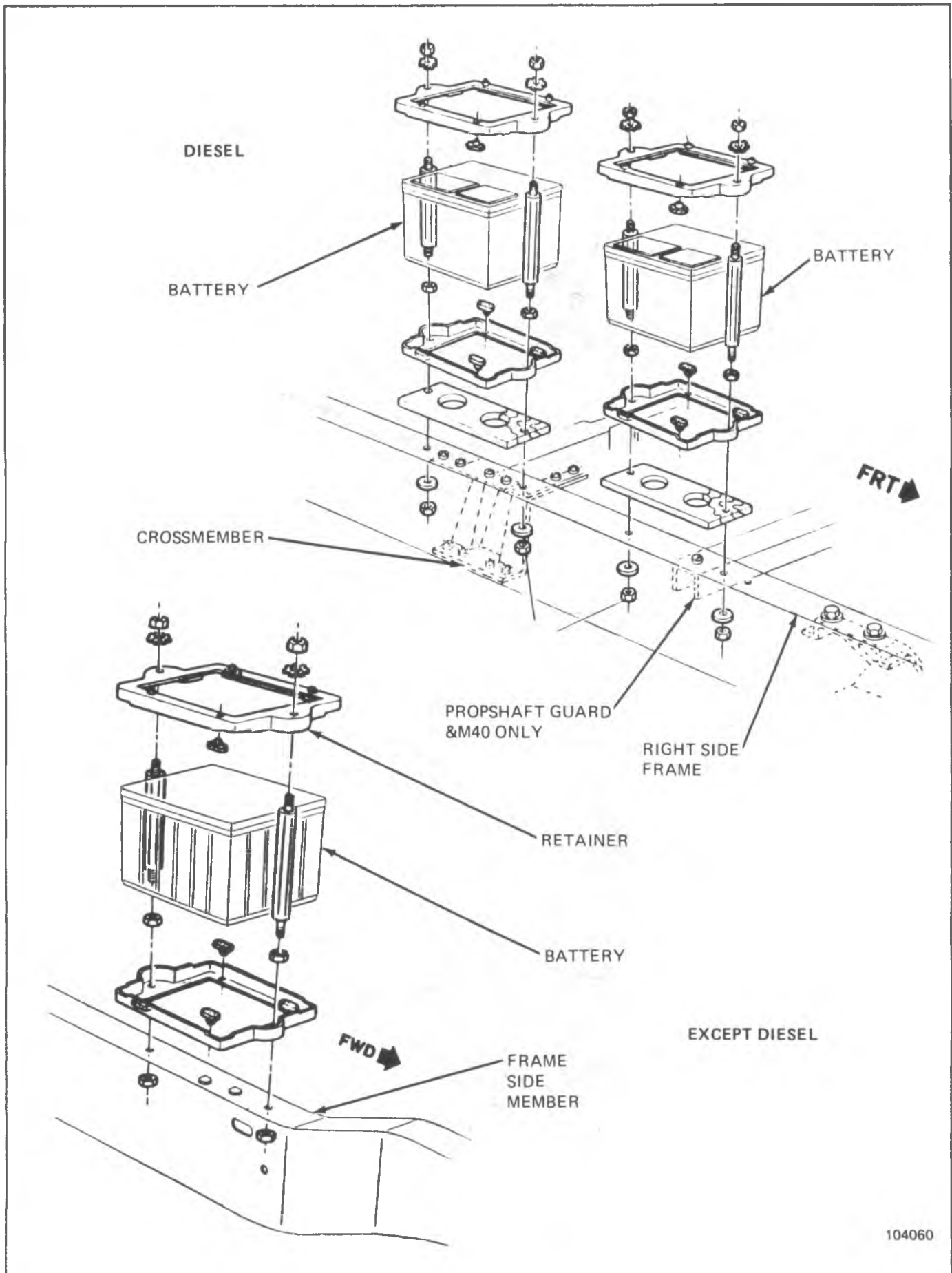

Fig. 6D-25--Battery Tray-P and E32/E33



104060

Fig. 6D-26--Battery Tray-P and LL4

## CHARGING SYSTEM

|                                       |       |                           |       |
|---------------------------------------|-------|---------------------------|-------|
| General Description .....             | 6D-21 | Overcharged Battery ..... | 6D-24 |
| Diagnosis .....                       | 6D-22 | On-Vehicle Service .....  | 6D-26 |
| Faulty Indicator Lamp Operation ..... | 6D-22 | Unit Repair .....         | 6D-27 |
| Undercharged tBattery .....           | 6D-24 |                           |       |

### GENERAL DESCRIPTION

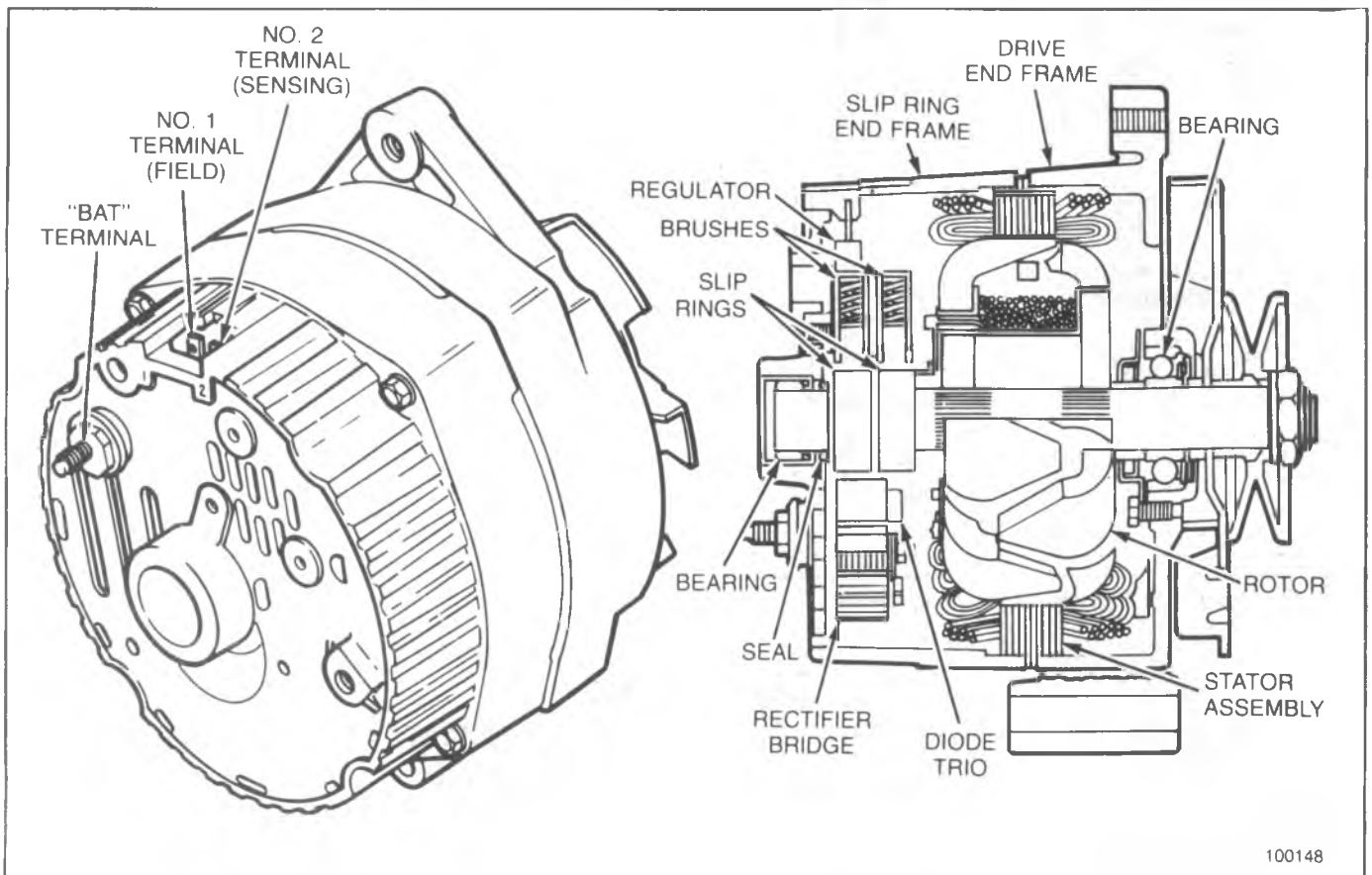

Fig. 6D-27--SI Generator-Typical

The basic charging system is the SI integral regulator charging system (Figure 6D-27). The internal components are connected electrically as shown in Fig. 6D-28. The generator is connected to the car electrically as shown in Section 8A under charging circuit.

The generator used on individual vehicles will be one of the following types: 10-SI, 12 SI, 15 SI, or 27 SI. The 15 SI and 27 SI generators have delta stator windings and cannot be checked for opens. The other differences among the four (4) types are output current ratings, and drive end and slip ring end bearing stack up. Specifications are given at the end of each subsection.

The brown field wire to the generator is used to turn on the generator. The 10 ohm resistance, provided by either the generator warning lamp, choke heater relay or the resistance wire is needed to protect the diode trio.

Several models of generators are available with different output ratings. Their basic operating principles are the same.

The generator features a solid state regulator that is mounted inside the generator. All regulator components are

enclosed into a solid mold, and this unit along with the brush holder assembly is attached to the slip ring end frame. The regulator voltage setting cannot be adjusted.

The generator rotor bearings contain enough grease to eliminate the need for periodic lubrication. Two brushes carry current through the two slip rings to the field coil mounted on the rotor, and under normal conditions will provide long periods of attention-free service.

The stator windings are assembled on the inside of a laminated core that forms part of the generator frame. A rectifier bridge connected to the stator windings contains six diodes, and electrically changes the stator a.c. voltages to a d.c. voltage which appears at the generator output terminal. Generator field current is supplied through a diode trio which also is connected to the stator windings. A capacitor or condenser, mounted in the end frame protects the rectifier bridge and diode trio from high voltages, and suppresses radio noise.

No periodic adjustments or maintenance of any kind are required on the entire generator assembly.

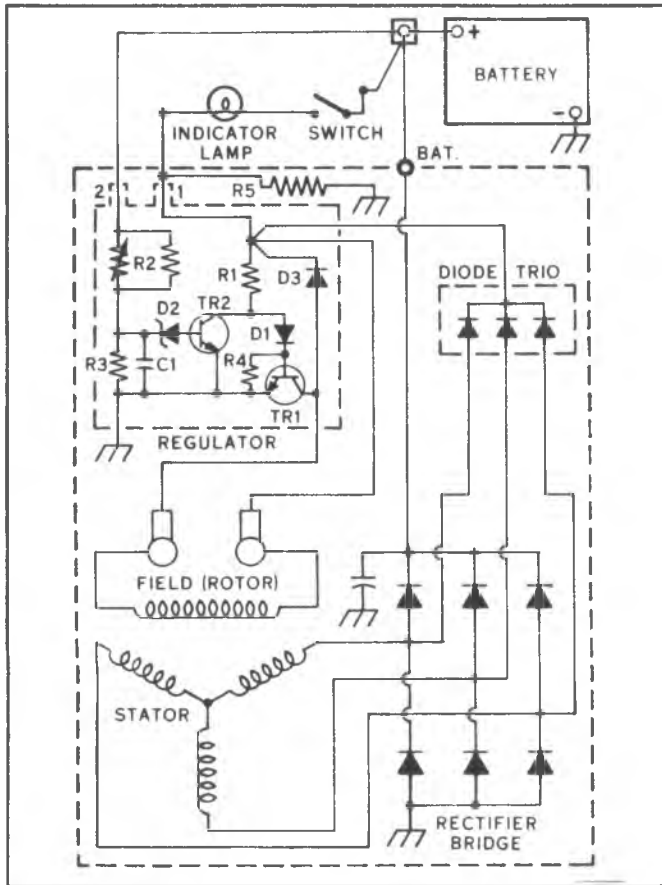

Fig. 6D-28--Regulator in Charging Circuit

## NOISY GENERATOR

Noise from a generator may be caused by a loose drive pulley, loose mounting bolts, worn or dirty bearings, defective diode, or defective stator.

## DIAGNOSIS

A charging circuit wiring diagram for generator connections is shown in the wiring diagrams.

To avoid damage, always follow these precautions:

- Do not reverse connections to the generator.
- Do not short across or ground any of the terminals in the charging circuit except as directed by the instructions.
- NEVER operate the generator with the output terminal disconnected.
- When connecting a charger or a booster battery to the vehicle battery, see Battery Charging Section.

In some cars, a voltmeter may be used instead of an indicator lamp. In this case, Section "A" pertaining to faulty indicator lamp operation should be omitted from the troubleshooting procedure.

Trouble in the charging system will show up as one or more of the following conditions:

- A. Faulty indicator lamp operation.
- B. An undercharged battery as evidenced by slow cranking or hydrometer dark.
- C. An overcharged battery as evidenced by excessive spewing of electrolyte from the vents.

### A. FAULTY INDICATOR LAMP OPERATION

Check the indicator lamp for normal operation as shown in Fig. 6D-29.

If the indicator lamp operates normally, proceed to "Undercharged Battery" section. Otherwise, proceed to one of the following three **abnormal** conditions.

1. **Switch Off, Lamp On** - Unplug the connector from the generator No. 1 and No. 2 terminals. If the lamp stays on, there is a short between these two leads. If the lamp goes out, replace the rectifier bridge as covered in the "GENERATOR REPAIR" Section. This condition will cause an undercharged battery.
2. **Switch On, Lamp Off, Engine Stopped** - This condition can be caused by the defects listed in part 1 above, or by an open in the circuit. To determine where an open exists, proceed as follows:
  - a. Check for a blown fuse, or fusible link, a burned out bulb, defective bulb socket, or an open in No. 1 lead circuit between generator and ignition switch.
  - b. If no defects have been found, proceed to Undercharged Battery section.
3. **Switch On, Lamp On, Engine Running** - Check for a

Fig. 6D-29--Charging System Diagnosis

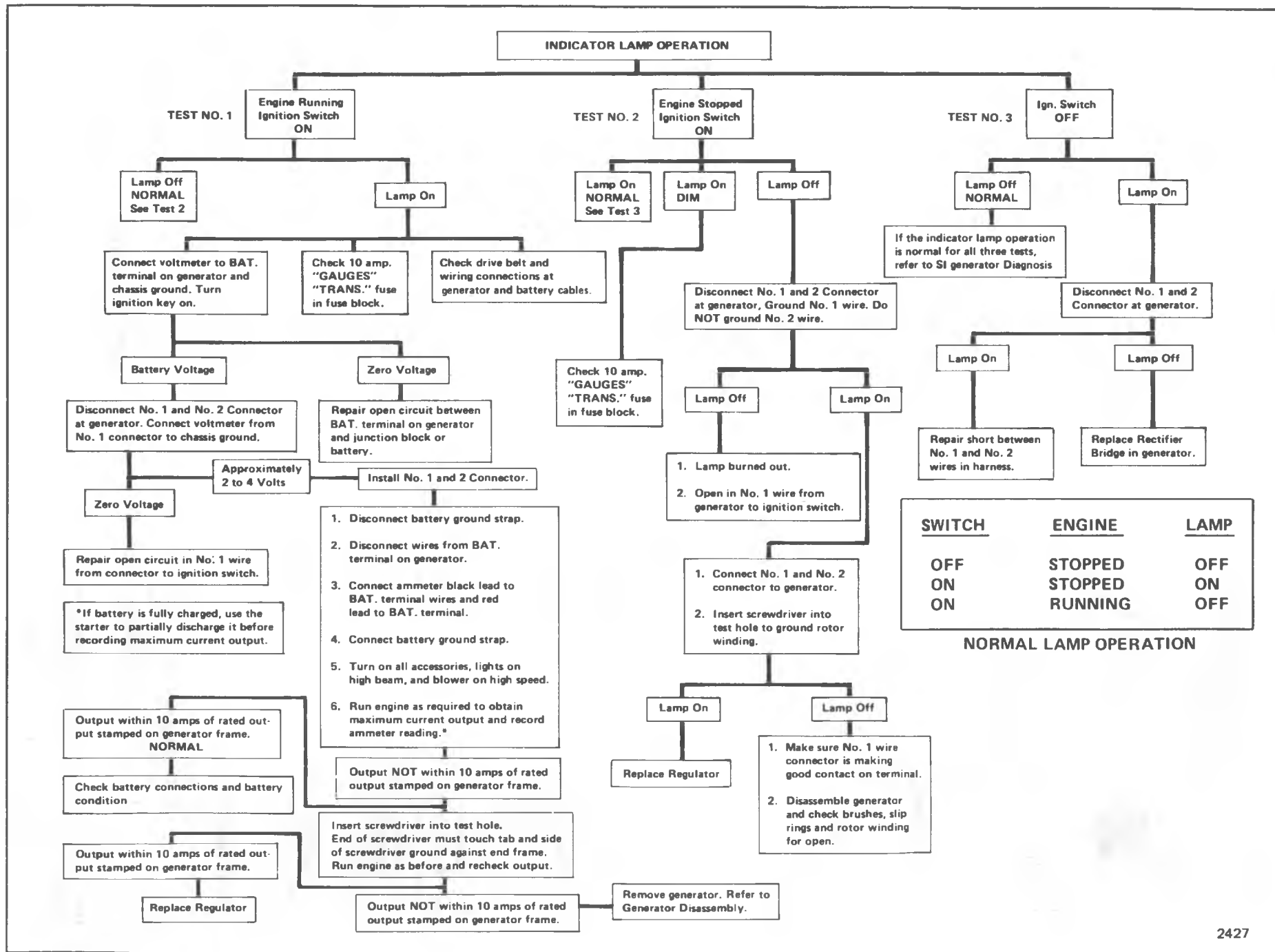

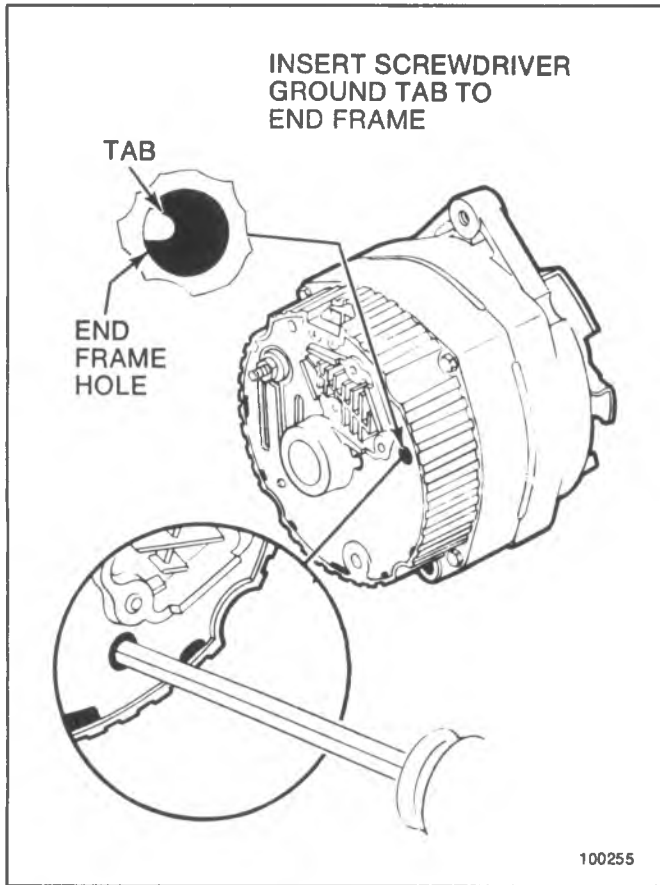

Fig. 6D-30--Generator Test Hole

blown fuse, (where used), between indicator lamp and switch, and also in A/C circuit. Other possible causes of this condition are covered in the "UNDERCHARGED BATTERY" section. If a defect has been found and corrected at this point, no further checks need be made.

#### B. Choke Light on After Start

If the generator fails to produce from 12 to 14.5 volts after the engine is running at a speed above idle, the choke heater relay will be grounded through the brown white wire to the generator at terminal 1. This will cause the relay points to remain open, thus stopping current flow back through the choke heater relay. This will cause the choke indicator to light.

1. Check generator terminal 1 for voltage during fast idle. If voltage is incorrect, see On-Vehicle Service and Unit Repair.

#### B. UNDERCHARGED BATTERY

This condition, as shown by slow cranking or hydrometer dark can be caused by one or more of the following conditions even though the indicator lamp may be operating normally. The following procedures also applies to cars with a voltmeter.

1. Insure that the undercharged condition has not been caused by accessories left on for extended periods.
2. Check the drive belt for proper tension (see Engine Cooling Section).

3. If a battery defect is suspected, refer to Battery Section.
4. Inspect the wiring for defects. Check all connections for tightness and cleanliness, including the slip connectors at the generator and bulkhead, and the battery cable connections at the battery, the starter and the ignition ground.
5. With ignition switch "on" and all wiring harness leads connected, connect a voltmeter from
  - a. Generator "BAT" terminal to ground.
  - b. Generator No. 1 terminal to ground.
  - c. Generator No. 2 terminal to ground.

A zero reading indicates an open between voltmeter connection and battery.

Generators have a built-in feature which avoids overcharge and accessory damage by preventing the generator from turning on if there is an **open** in the wiring harness connected to the No. 2 (sensing) generator terminal.

6. If Steps 1 through 5 check satisfactorily, check generator as follows:
  - a. Disconnect negative battery cable.
  - b. Connect an ammeter or generator tester in the circuit at the "BAT" terminal of the generator.
  - c. Reconnect negative battery cable.
  - d. Turn on radio, windshield wipers, lights high beam and blower motor on high speed. Connect a carbon pile across the battery (or use generator tester).
  - e. Operate engine about 2000 RPM, and adjust carbon pile as required, to obtain maximum current output.
  - f. If ampere output is within 10 amperes of rated output as stamped on generator frame, generator is not defective; recheck Steps 1 through 5.
  - g. If ampere output is not within 10 percent of rated output, determine if test hole is accessible (Fig. 6D-32). If accessible go to step h. If not accessible go to step l.
  - h. Ground the field winding by inserting a screwdriver into the test hole (Fig. 6D-30). Tab is within 19mm (3/4 inch) of casting surface. Do not force screwdriver deeper than one inch (25mm) into end frame to avoid damaging generator.
  - i. Operate engine at moderate speed as required, and adjust carbon pile as required to obtain maximum current output.
  - j. If output is within 10 amperes of rated output, check field winding, diode trio, and rectifier bridge as covered in UNIT REPAIR section, and test regulator with an approved regulator tester.
  - k. If output is not within 10 amperes of rated output, check the field winding, diode trio, rectifier bridge, and stator as covered in the UNIT REPAIR Section.
  - l. If test hole is not accessible, disassemble generator and make tests listed in UNIT REPAIR section.

#### C. OVERCHARGED BATTERY

1. To determine battery condition refer to Battery section.
2. If an obvious overcharge condition exists as evidenced by excessive spewing of electrolyte, proceed to disassembly section of "Unit Repair" and check field windings for grounds and shorts. If

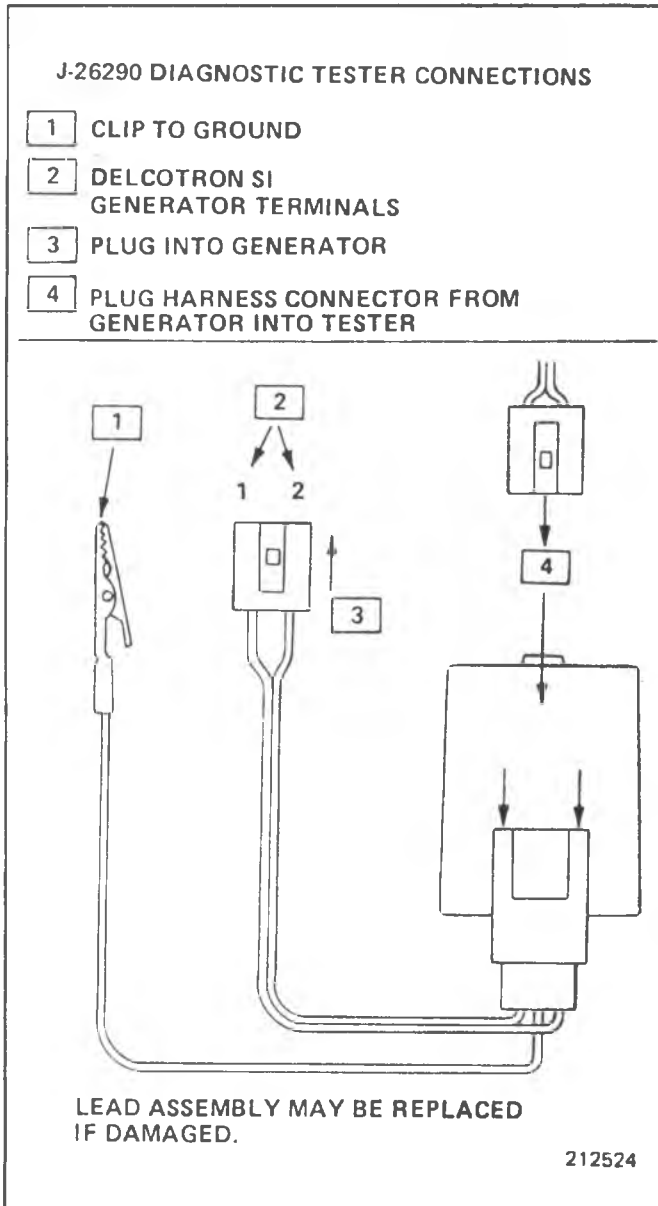

Fig. 6D-31--J-26290 Diagnostic Tester Connections

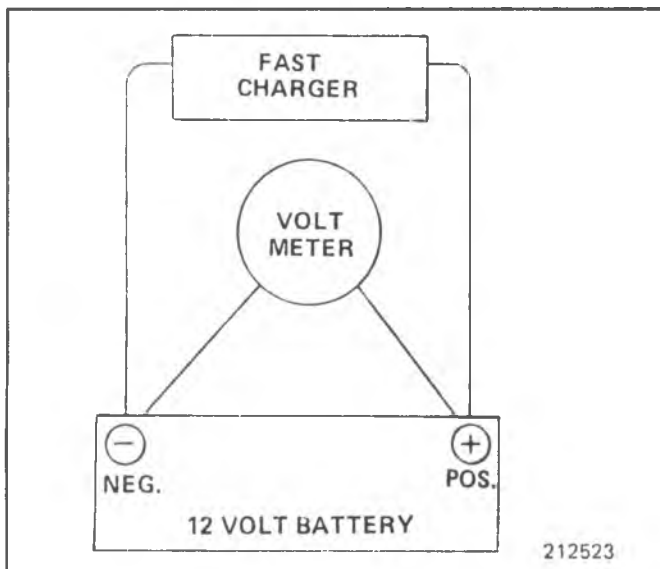

Fig. 6D-32--On Car Voltage Regulator Test

defective, replace rotor, and test regulator with an approved regulator tester.

Generator Tester - many testers are available to check the generator. They provide a quick on-car test, and can save time over conventional diagnostic methods. Consult manufacturer's instructions for usage.

**GENERATOR DIAGNOSTIC TESTER INDICATIONS (TOOL J-26290)**

This tester is designed as a quick check to determine if the generator should be removed from the vehicle. It will indicate about 98% of charging system faults.

Be certain engine is at fast idle when using tester in Part 2.

Connect tester as shown in Fig. 6D-31.

1. Engine Off: (Lights and Accessories Off)
  - a. Light flashes--Skip Steps b and c and go to Part 2.
  - b. Light on--Indicates fault in tester which should be replaced.
  - c. Light off--Pull plug from generator:
    - (1) Flashing light--indicates that the generator should be removed and the rectifier bridge replaced.
    - (2) Light off--indicates faulty tester or no voltage to tester. Check for 12-volts at #2 terminal of harness connector. Repair wiring or terminals if 12-volts is not available. Replace tester if 12-volts is available.
2. Engine at Fast Idle: (Lights and Accessories Off)

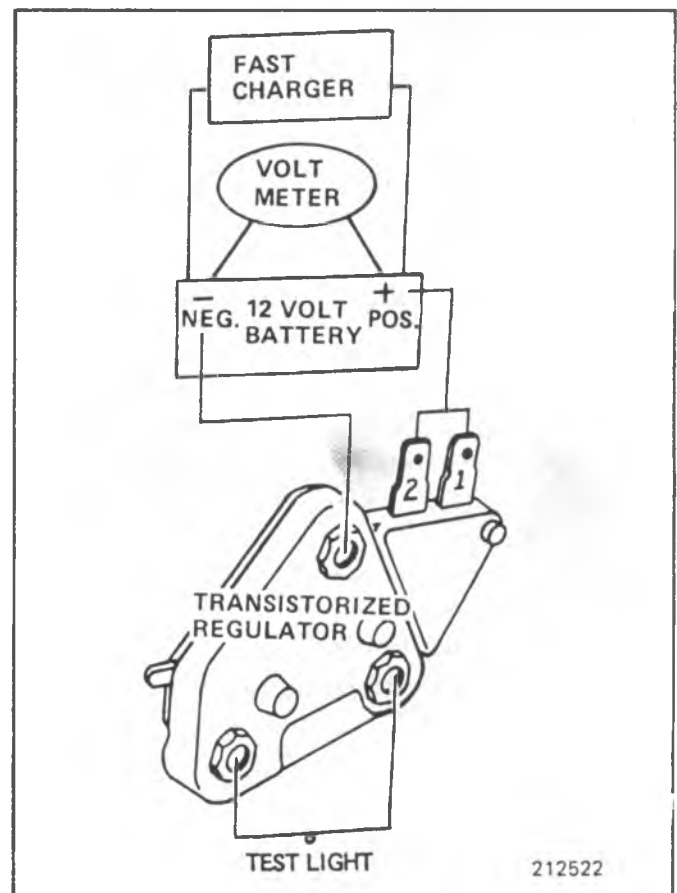

Fig. 6D-33--Off Car Voltage Regulator Test



- d. Light off--Charging system good, DO NOT remove generator.
- e. Light on--Indicates a component failure within the generator. Remove generator and check diode trio, rectifier bridge and stator.
- f. Light flashing--Indicates a problem within the generator. Remove generator and check regulator, rotor field coil, brushes and slip rings.

2. Turn on the ignition and slowly increase the charge rate. The generator light in the vehicle will dim at the voltage regulator setting. Voltage regulator setting should be a minimum of 13.5 volts and a maximum of 16.0 volts.

**NOTICE:** This test works if the rotor circuit is good, even if the stator rectifier bridge or diode trio is bad.

## TRANSISTORIZED VOLTAGE REGULATOR TEST

### Procedure

1. Connect a fast charger and a voltmeter to the battery as shown in Fig. 6D-32.

## ON-VEHICLE SERVICE

The generator does not require periodic lubrication. The rotor shaft is mounted on ball bearings at the drive end and roller bearings at the slip ring end, and each contains a permanent grease supply. At periodic intervals, check mounting bolts for tightness and adjust belt tension (see Sec. 6B).

- When adjusting belt tension, apply pressure at center of generator, never against either end frame.

### TESTING VOLTAGE REGULATOR - OFF CAR

1. Connect voltmeter and fast charger to 12-volt battery as shown in Fig. 6D-33.

2. Connect regulator and test light as shown, observe battery polarity.
3. Test light should be on.
4. Turn on fast charger and slowly increase charge rate. Observe voltmeter, light should go out at the voltage regulator setting. Voltage regulator setting should be a minimum of 13.5 volts and a maximum of 16.0 volts.

The test light is connected into the circuit, exactly as the rotor is when the regulator is inside the generator. The regulator shuts off the current to the test light when the regulator setting is reached. This voltage will vary with temperature differences.

## UNIT REPAIR

### SLIP RING SERVICING

If the slip rings are dirty, they may be cleaned and finished with 400 grain or finer polishing cloth. Spin the rotor, and hold the polishing cloth against the slip rings until they are clean.

**NOTICE:** The rotor must be rotated in order to clean the slip rings evenly. Cleaning the slip rings by hand

without spinning the rotor may result in flat spots on the slip rings, causing brush noise.

Slip rings which are rough or out of round should be trued in a lathe to .002 inch maximum indicator reading. Remove only enough material to make the rings smooth and round. Finish with 400 grain or finer polishing cloth and blow away all dust.

The illustrations which follow should be used when unit repair to the generator becomes necessary.

### Remove

1. Disconnect negative battery terminal at battery.
 

**CAUTION: Failure to observe this step may result in an injury from hot battery lead at generator.**
2. Remove two terminal plug and battery leads on back of generator.
3. Loosen adjusting bolts (see Fig. 6D-37. to 6D-41 for generator mounting).
4. Remove generator drive belt.
5. Remove thru bolt which retains generator.

6. Remove generator from vehicle.

### Install

1. If removed from vehicle, install generator to mounting bracket with bolts, washers and nuts. Do not tighten.
2. Install generator drive belt.
3. Tighten belt to the specified belt tension. See Engine Cooling Section for proper belt tensioning procedures.
4. Tighten bolts.
5. Install generator terminal plug and battery leads to generator.
6. Connect negative battery terminal.

## DISASSEMBLY, TEST AND REASSEMBLY (GENERATOR REMOVED FROM ENGINE)

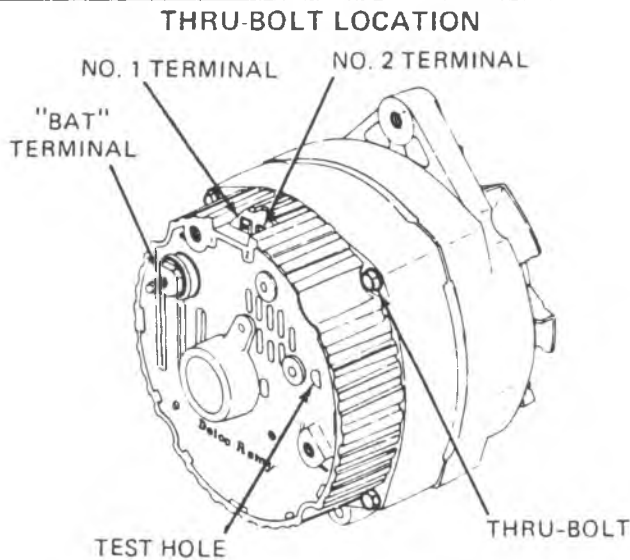

1. Make scribe marks on end frames to facilitate reassembly.
2. Remove four thru-bolts and separate drive end frame assembly from rectifier end frame assembly.

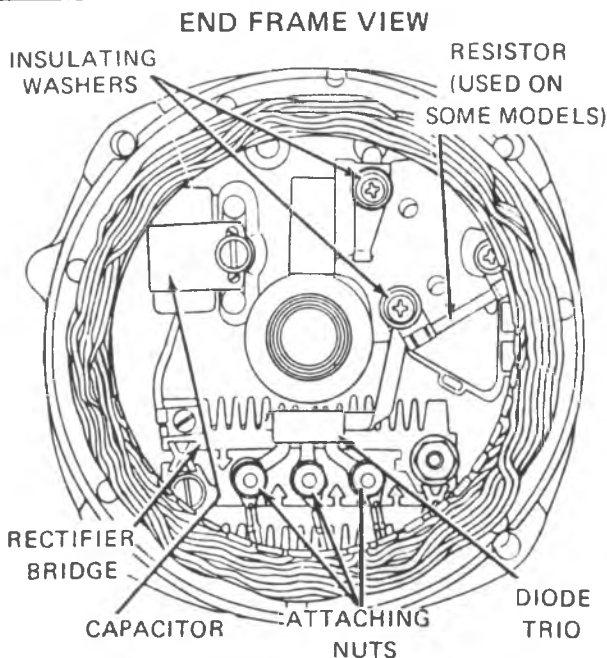

3. Remove three attaching nuts and regulator attaching screws.
4. Separate stator, diode trio and regulator from end frame.  
NOTE: The regulator cannot be tested on the work bench except with a regulator tester.

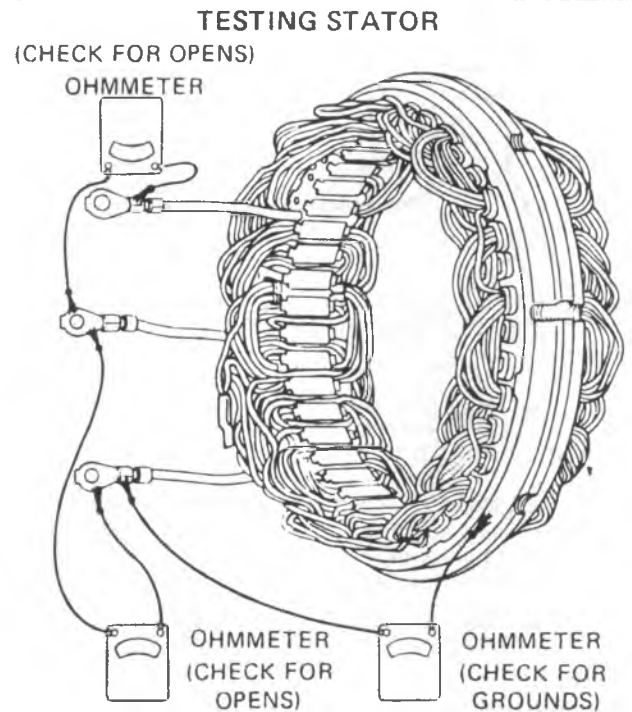

5. On 10SI only, check stator for opens with ohmmeter (two checks). If either reading is high (infinite), replace stator.
6. On all series, check stator for grounds. If reading is low, replace stator.

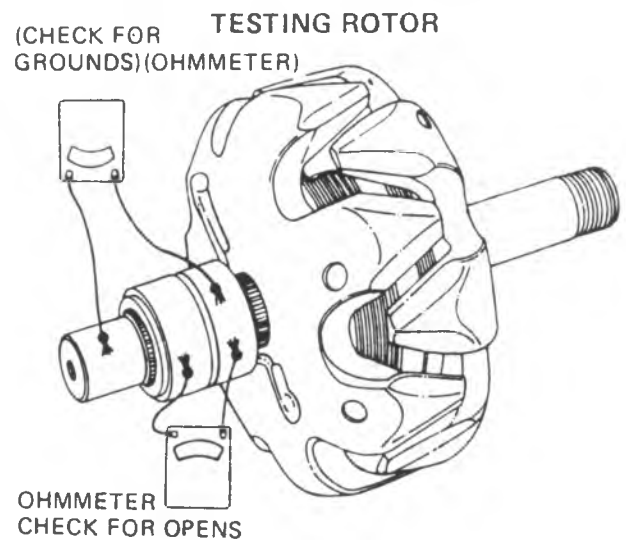

7. Check rotor for grounds with ohmmeter. Reading should be very high (infinite). If not, replace rotor.
8. Check rotor for opens. Should read 2.4-3.5 ohms. If not, replace rotor.

212623

Fig. 6D-34-Generator Unit Repair - 1 of 3

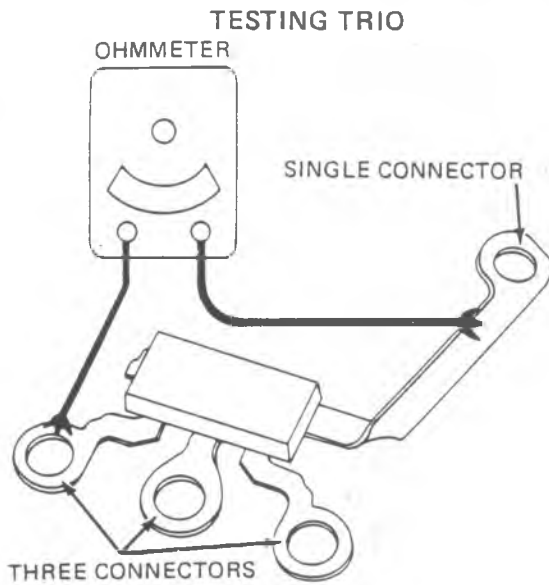

9. To check diode trio, connect ohmmeter as shown, then reverse lead connections. Should read high and low. If not, replace diode trio.
10. Repeat same test between single connector and each of other connectors.

**TESTING RECTIFIER BRIDGE**

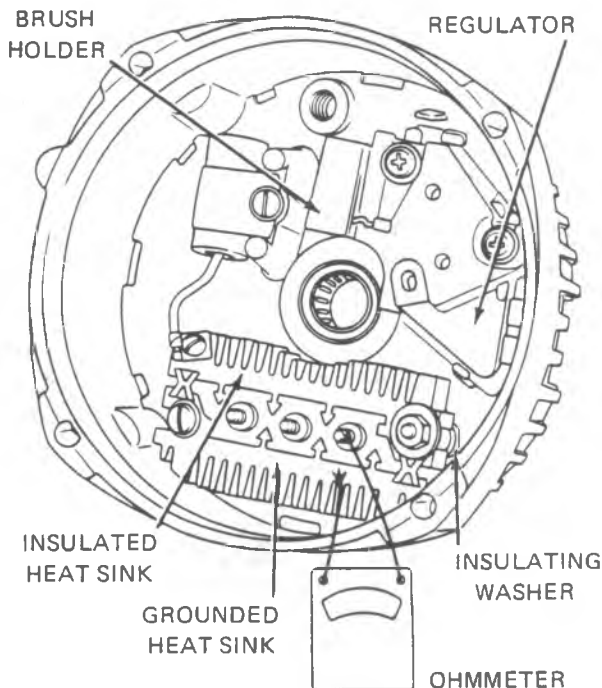

11. Check rectifier bridge with ohmmeter connected from grounded heat sink to flat metal on terminal. Reverse leads. If both readings are the same, replace rectifier bridge.
12. Repeat test between grounded heat sink and other two flat metal clips.
13. Repeat test between insulated heat sink and three flat metal clips.  
To replace bridge, remove attaching screws.

**BRUSHES RETAINED IN HOLDER**

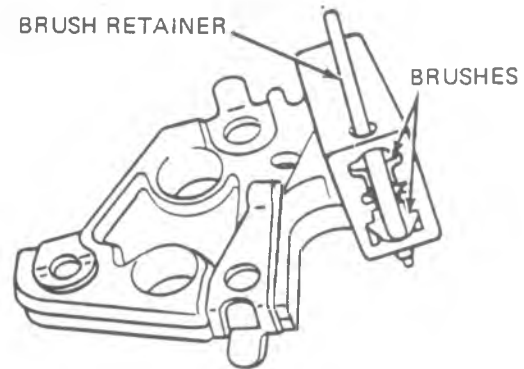

14. Clean brushes with soft, dry cloth.
15. Put brushes in holder and hold with brush retainer wire.

**DRIVE END BEARING**

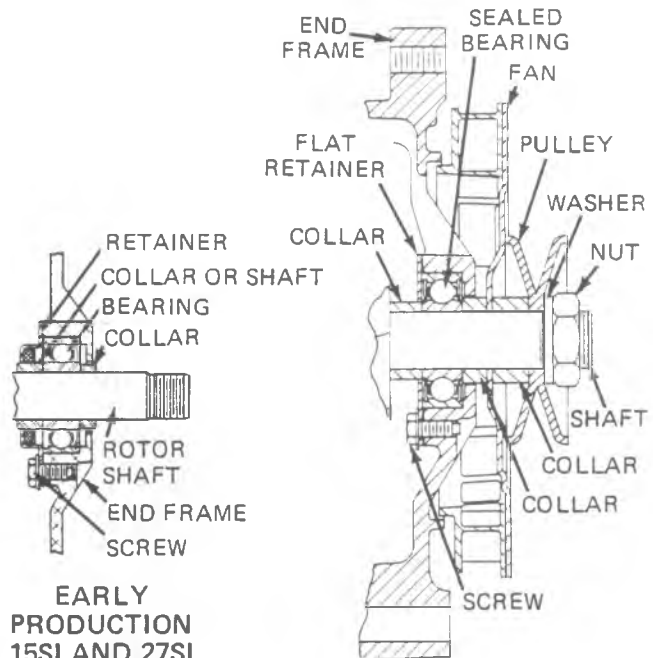

EARLY PRODUCTION 15SI AND 27SI

10SI, 12SI, AND LATE PRODUCTION 15SI AND 27SI

16. Observe stack-up of parts in both illustrations.  
To remove rotor and drive end bearing, remove shaft nut, washer and pulley, fan and collar. Push rotor from housing.
17. Remove retainer plate inside drive end frame and push bearing out. Clean all parts with soft cloth.
18. Press against outer race to push bearing in. Fill cavity between retainer plate and bearing with lubricant on early production 15SI and 27SI. Series 10SI, 12SI and late production 15SI and 27SI use sealed bearing - no lubricant is required. Assemble retainer plate.
19. Press rotor into end frame. Assemble collar, fan, pulley, washer and nut. Torque shaft nut to 40-60 lb.-ft., (54-82 N-M).

212624

## RECTIFIER END BEARING 15SI SERIES

USE THIN WALL TUBE  
IN SPACE BETWEEN  
GREASE CUP AND  
HOUSING TO PUSH  
BEARING IN FLUSH  
WITH HOUSING

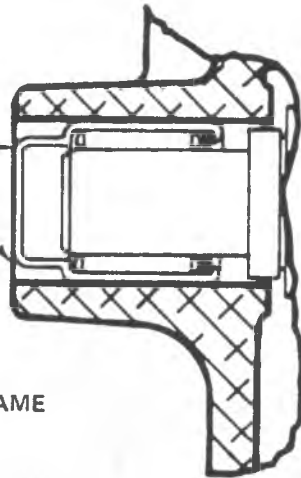

PARTIAL VIEW  
RECTIFIER END FRAME  
15SI/100

20. PUSH SLIP RING END BEARING OUT FROM OUTSIDE TOWARD INSIDE OF END FRAME.
21. ON 10SI AND 12SI, PLACE FLAT PLATE OVER NEW BEARING, PRESS FROM OUTSIDE TOWARD INSIDE UNTIL BEARING IS FLUSH WITH END FRAME.
22. ON 15SI, SEE ILLUSTRATION.
23. ASSEMBLE BRUSH HOLDER, REGULATOR, RESISTOR, DIODE TRIO, RECTIFIER BRIDGE AND STATOR TO SLIP RING END FRAME.
24. ASSEMBLE END FRAMES TOGETHER WITH THRU-BOLTS. REMOVE BRUSH RETAINER WIRE.

212621

Fig. 6D-36--Generator Unit Repair - 3 of 3

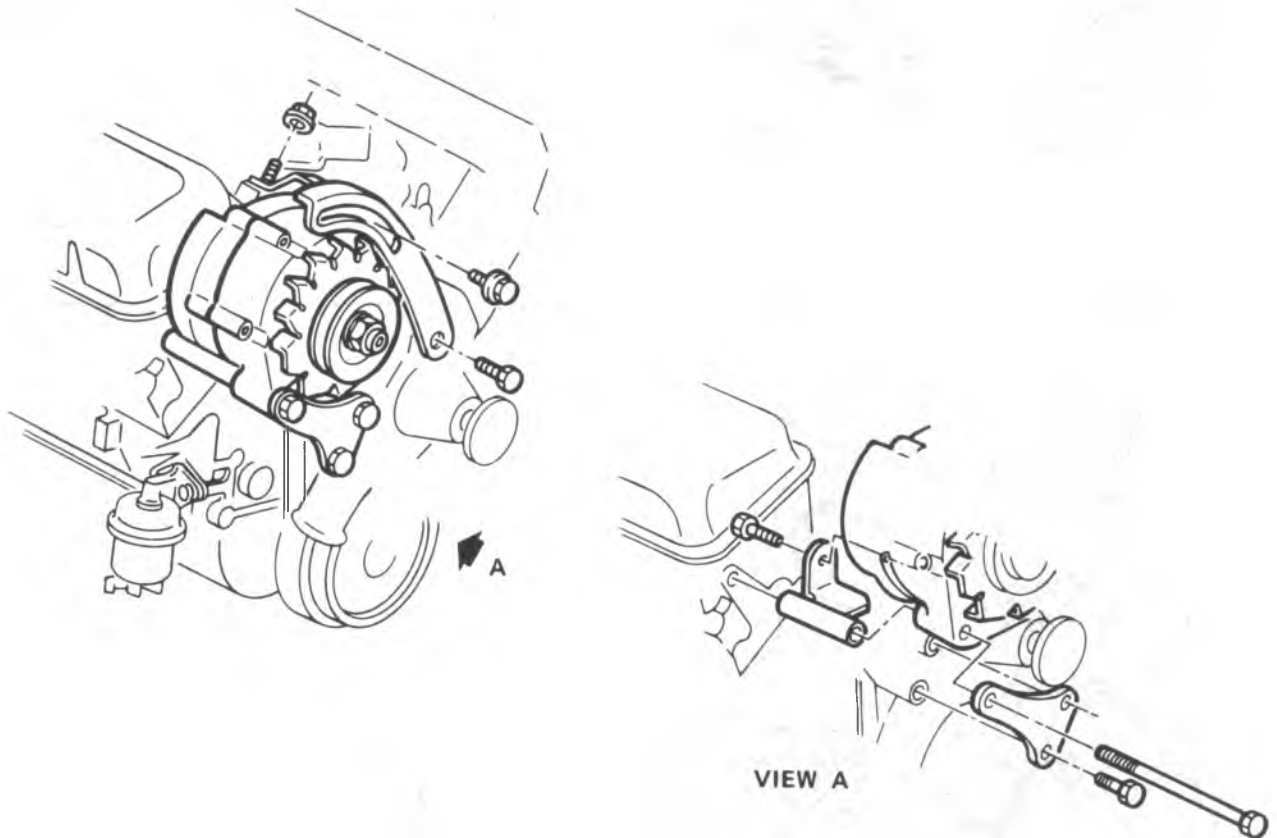

Fig. 6D-37--Generator Mounting-LE8/LT9

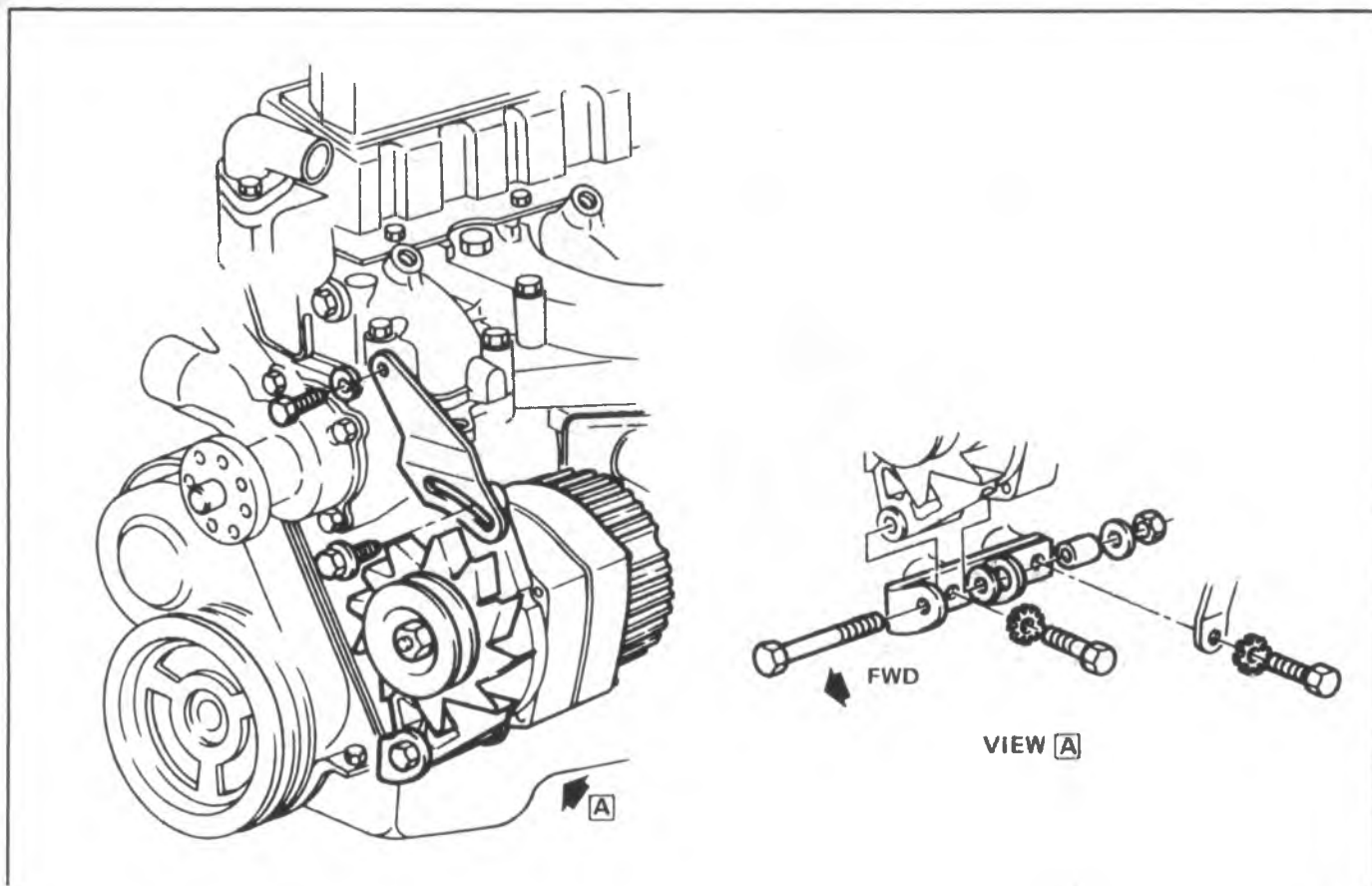

Fig. 6D-38--Generator Mounting-LE3

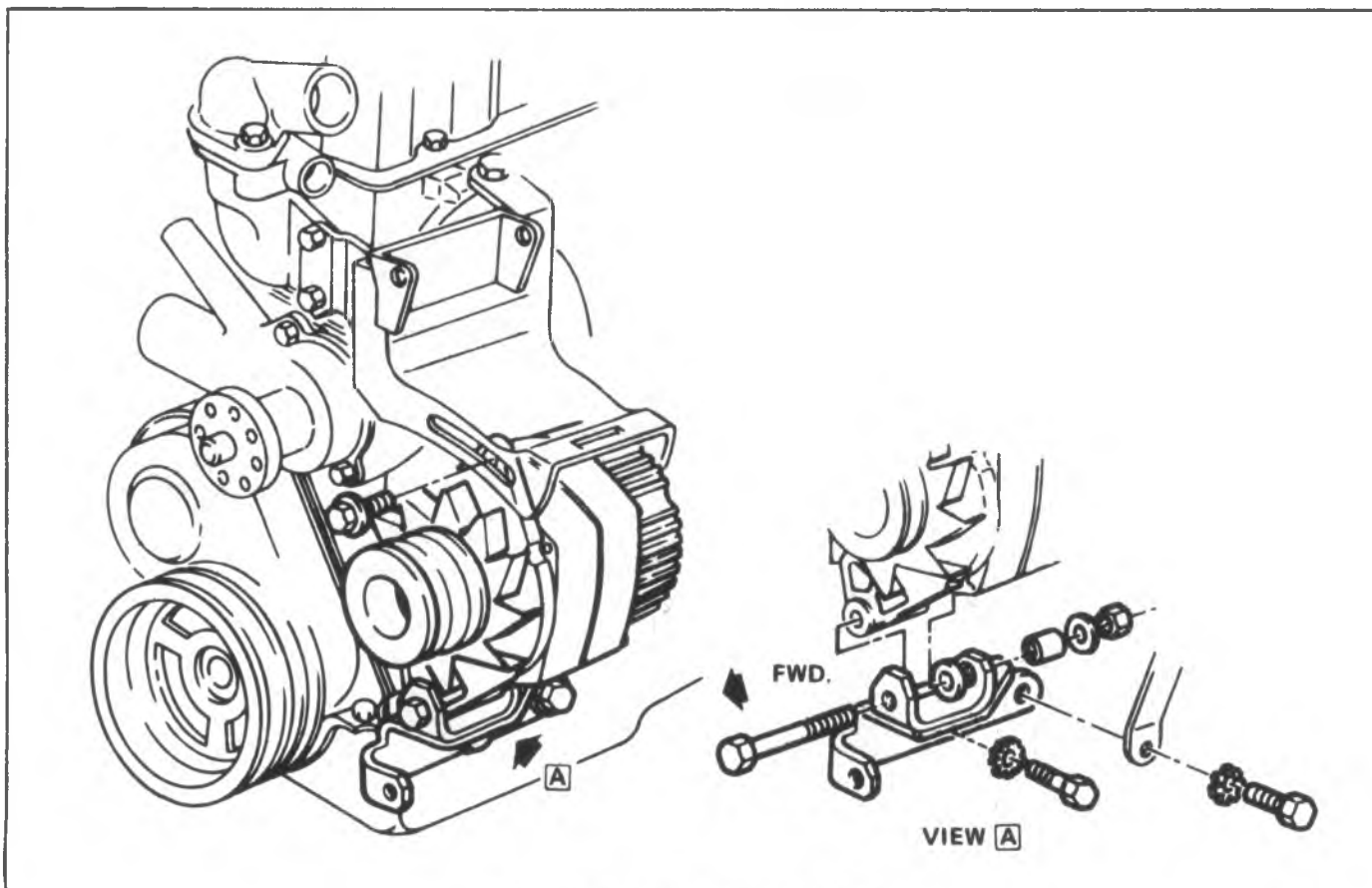

Fig. 6D-39--Generator Mounting-L25

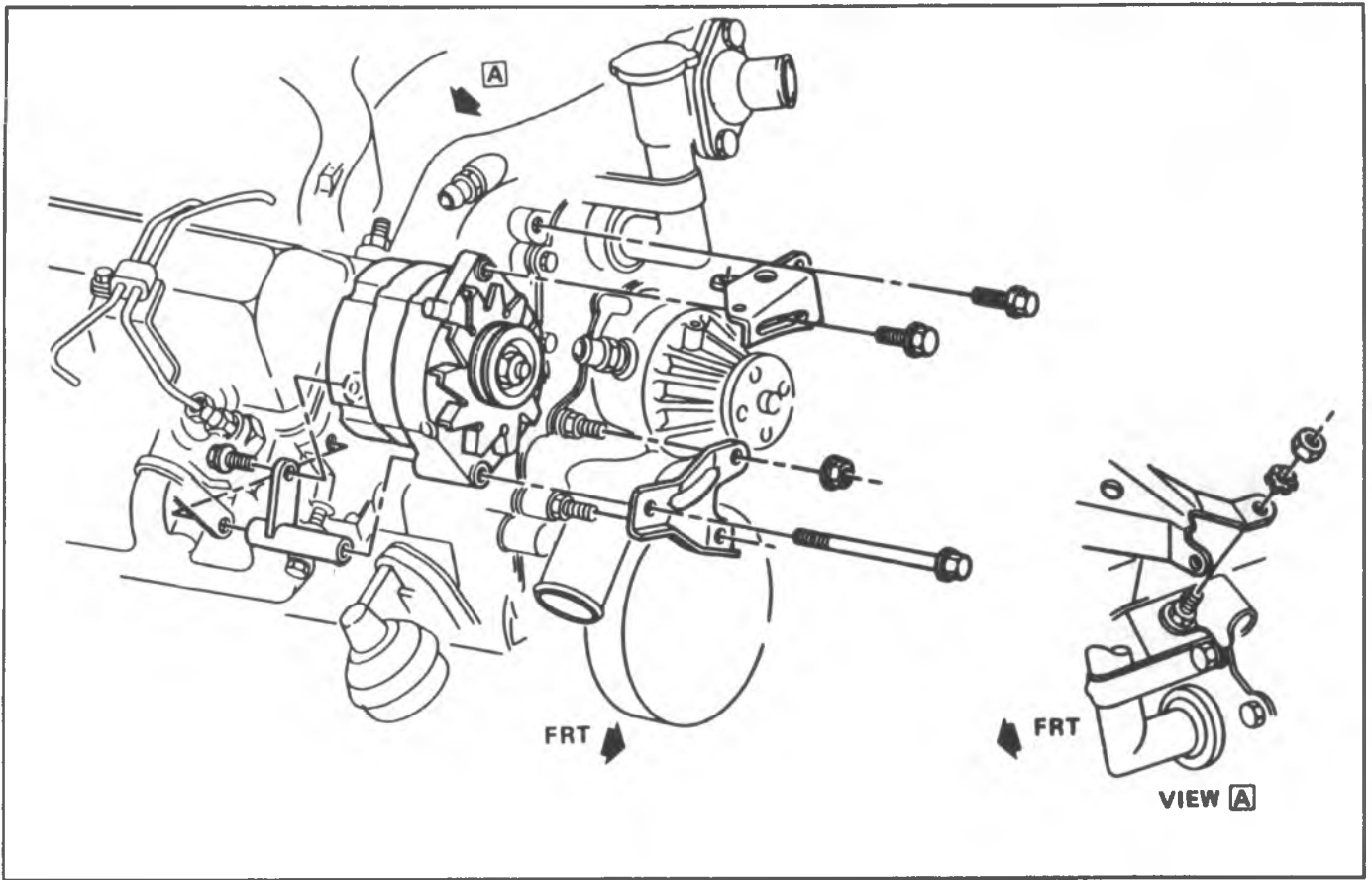

Fig. 6D-40--Generator Mounting-Diesel

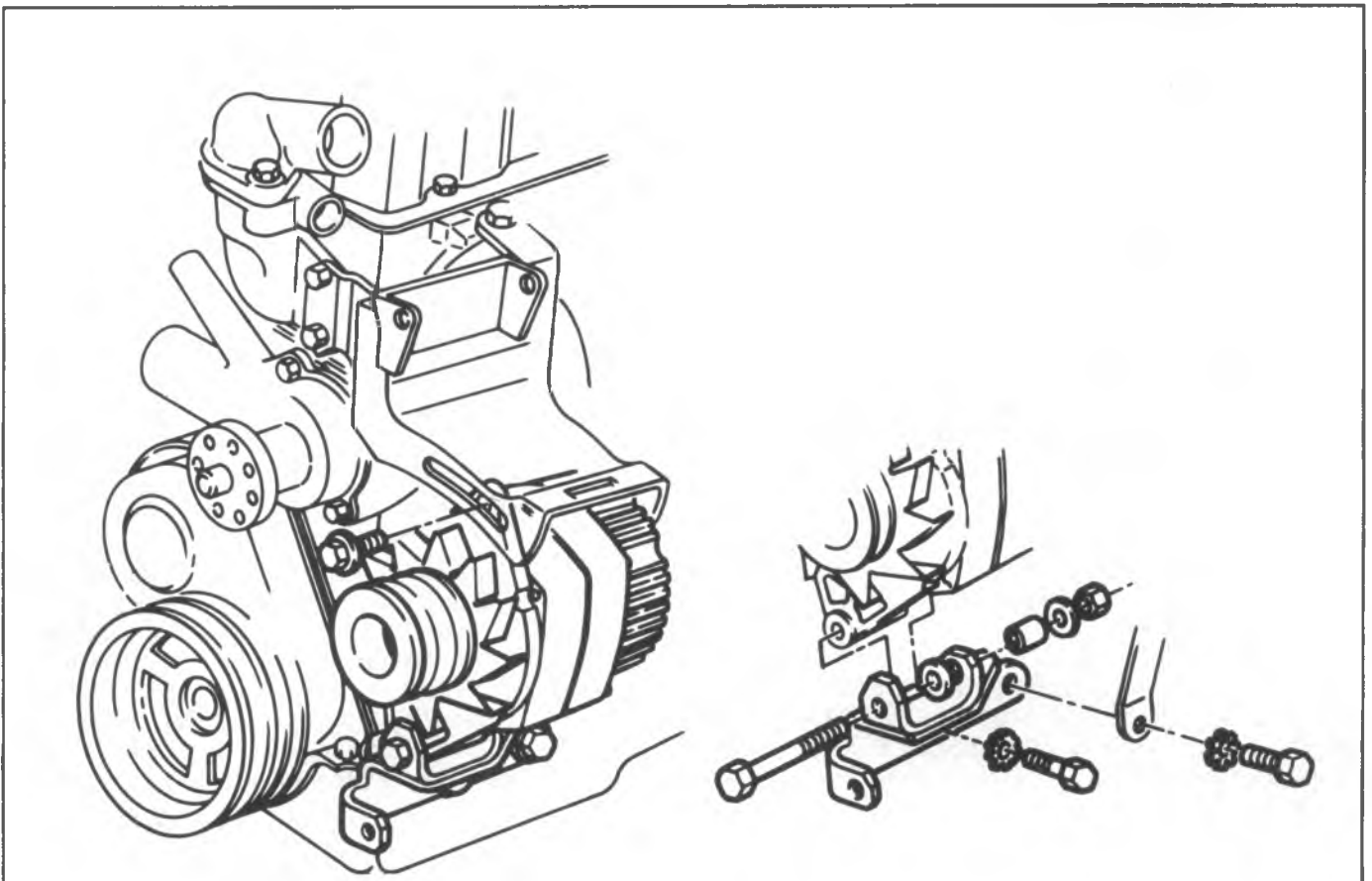

Fig. 6D-41--Generator Mounting-P300 (42) L25

## 6.2L Diesel Glow Plug Electrical System

In the diesel engine, air alone is compressed in the cylinder; then after the air has been compressed a charge of fuel is sprayed into the cylinder and ignition occurs due to the heat of compression. Eight glow plugs are used to preheat the chamber as an aid to starting.

They are 6 volt heaters (operated at 12 volts) that turn on when the ignition key is turned to the run position prior to starting the engine. They remain pulsing a short time after starting, then automatically turn off.

### General Description

The 6.2 liter diesel glow plug control system consists of a thermal controller, glow plug relay, 6 volt glow plugs, and a "Glow Plugs" lamp. Other components which have no function in controlling glow plug operation but are part of the electrical system start and run operations are: fuel solenoid, fast idle and cold advance solenoids, cold advance temperature switch, and the TCC, EGR and EPR solenoids. The electrical operation and diagnosis of the fuel solenoid, fast idle and cold advance solenoid and the cold advance temperature switch will be covered briefly here. Refer to Section 7, Transmissions for information on the TCC system and to Section 6E, Emissions for information on the EGR and EPR systems.

#### Controller

The thermal controller is mounted in the water passage at the rear of the engine. Thermostatic elements within the controller are designed to open or close the ground circuit to the glow plug relay as necessary to control the pre-heat and afterglow cycles of glow plug operation.

#### Glow Plug Relay

The glow plug relay located on the left inner fender panel provides current to the glow plugs. The relay is pulsed on and off by the thermal controller.

**NOTICE:** This relay is automatically controlled. Any attempt to bypass relay with jumper wire or rewire for manual control may result in glow plug failure.

#### Glow Plugs

The glow plugs used in this system are 6 volt plugs which are operated at electrical system voltage (12 volts). They are not designed to burn continuously, and are pulsed on and off as needed, by the thermal controller.

#### Glow Plugs Lamp

The glow plugs lamp is mounted in the instrument cluster. The lamp is wired across the glow plugs and is illuminated whenever the glow plugs are heating.

#### Fuel solenoid

The fuel solenoid is activated whenever the ignition switch is on. The solenoid is located in the fuel injection pump housing cover. Refer to the Engine Fuel Section of this manual for service.

#### Instrumentation

Vehicles with the diesel engine have special instrumentation indicators to permit the operator to properly apply the starting procedure. A Glow Plugs light on the I.P. provides this information on engine starting conditions.

Also, these vehicles have a water in fuel lamp and low engine coolant lamp. Refer to the engine fuel and engine cooling sections for information on these systems.

#### Cold Advance Solenoid

the cold advance solenoid, also located in the injection pump cover, is controlled by a cold advance temperature switch which activates this solenoid and the fast idle solenoid at a specified minimum temperature. The switch should be closed below 90°F and open above 122°F.

#### BATTERY

the diesel engine uses dual batteries to provide the extra power required to operate the glow plugs and the larger starter used on this engine.

A Standard generator supplies charging current to both batteries at the same time. There are no switches or relays in the charging circuit.

#### Starter

The starter is larger and designed to crank the engine at least the 100 RPM required for starting.

#### Circuit Operation - Cold Start

With the ignition switch in "Run" the following events take place simultaneously.

1. The fuel solenoid is energized opening the fuel metering valve. The fuel heater is powered provided the temperature is low enough to require heating of the fuel.
2. Battery voltage is applied to the Fast Idle solenoid and Cold Advance solenoid through the Fast Idle/Cold Advance temperature switch (when closed).
3. Battery current flows through the thermal controller circuits and through the glow plug relay coil to ground.
4. the Glow Plugs lamp which is wired across the glow plugs, comes on whenever the Glow Plugs are powered.
5. The thermal controller starts the glow plugs heating cycle.

Initially, the glow plugs are activated continuously for a period of 7 1/2 to 9 seconds at 0°F. The glow plugs then begin to pulse on and off at a rate determined by the thermal characteristics of the controller. The initial current brings the glow plug preheat chamber up to the temperature required for cold starting. The pulse cycle (on and off) acts to maintain chamber temperature to provide stable engine warm up. As the engine warms up, the thermal

controller turns off all current to the relay de-energizing the glow plugs completely. The controller is capable of varying glow plug operation as required (up to one minute) when the engine is started warm, and little or no heating is necessary.

Controller failure as in the case of prolonged preheat (more than 9 seconds) would cause a circuit breaker in the controller to open, cutting off glow plug operation completely.

## **Diesel Glow Plug Electrical System Diagnosis**

Before attempting any diagnosis of problems in the glow plug electrical system, insure that connectors are installed properly and that all connections are clean and tight.

### **STARTER/GENERATOR MOUNTING**

Starter and Generator mounting is illustrated in Figures 6D-43 through 6D-45.



## 6.2L. DIESEL ELECTRICAL SYSTEM DIAGNOSIS

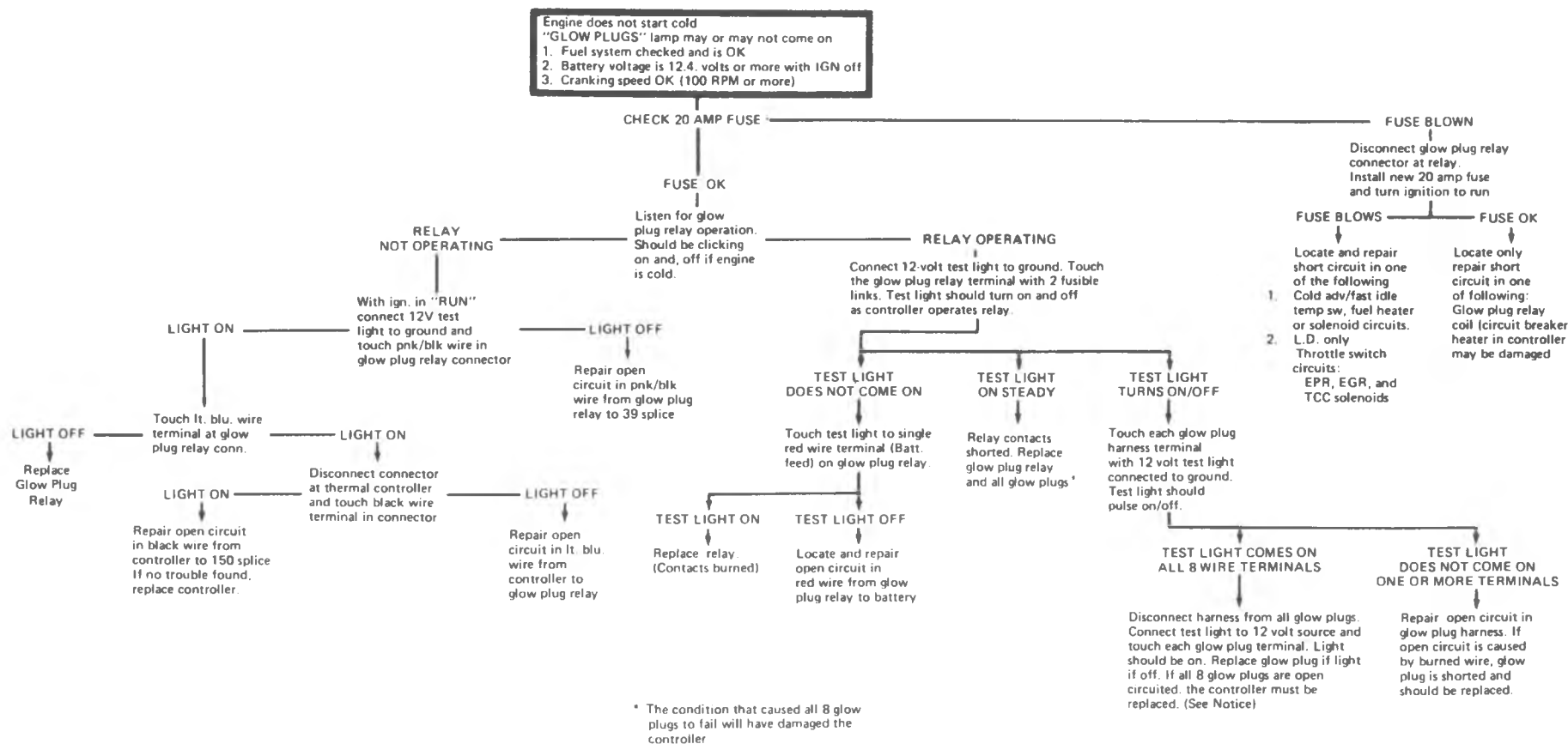

**THERMAL CONTROLLER CHECK**

With connector removed from controller the controller heater circuits may be checked using a high impedance ohmmeter. However, this check will not determine shorted switches within the controller.

Pin 3 – Pin 2 .40 to .75  $\Omega$

Pin 5 – Pin 1 130  $\Omega \pm 10\%$

Pin 4 – Pin 5 27  $\Omega \pm 3 \Omega$

Pin 2 – Pin 6 Continuity ("0" ohms)

**GLOW PLUGS LAMP  
CYCLES ON AND OFF  
WARM ENGINE**

This condition can be caused by an open circuit in 25 circuit from gen telltale output to pin 1 of the controller, or by generator output failure – to check generator operation, see Section 6D of this manual.

## 6.2 LITER DIESEL ELECTRICAL SYSTEM DIAGNOSIS

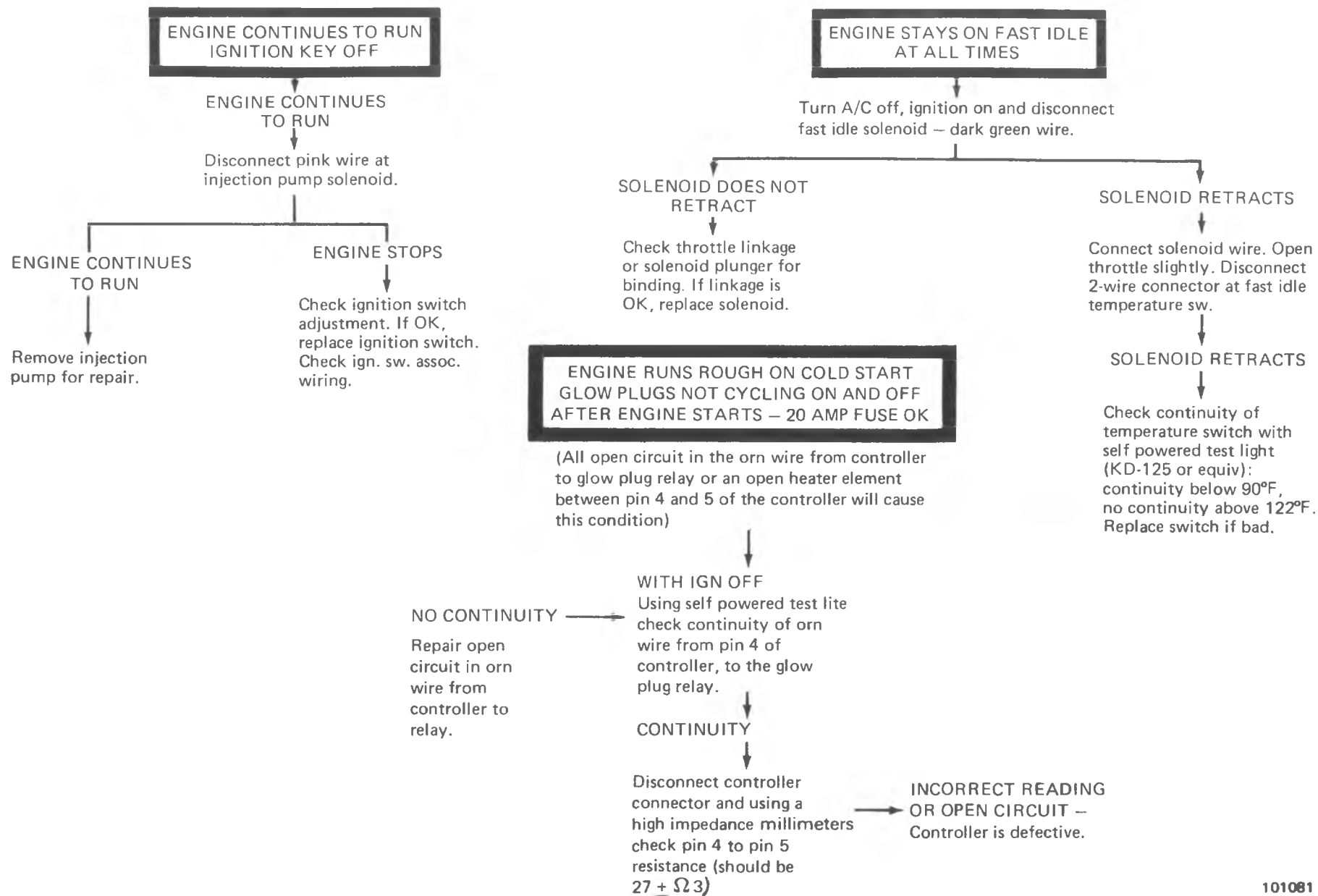

101081

6.2 LITER DIESEL ELECTRICAL DIAGNOSIS

**NO GLOW PLUGS LAMP –**

1. Check 20 Amp Fuse  
FUSE OK

With ignition in "Run"  
Check for glow plug relay operation  
by listening for click at relay.

Relay clicking

Not clicking

With ignition switch OFF  
Check continuity of BLK wire circuit 150A,  
from bulb socket to fuse block bus bar grd.

go to  
"Engine does not  
start cold" chart  
(relay not operating).

Continuity

No Continuity

Check continuity of ORN/BLK wire  
circuit 503 from bulb socket to  
splice 503

Repair as necessary

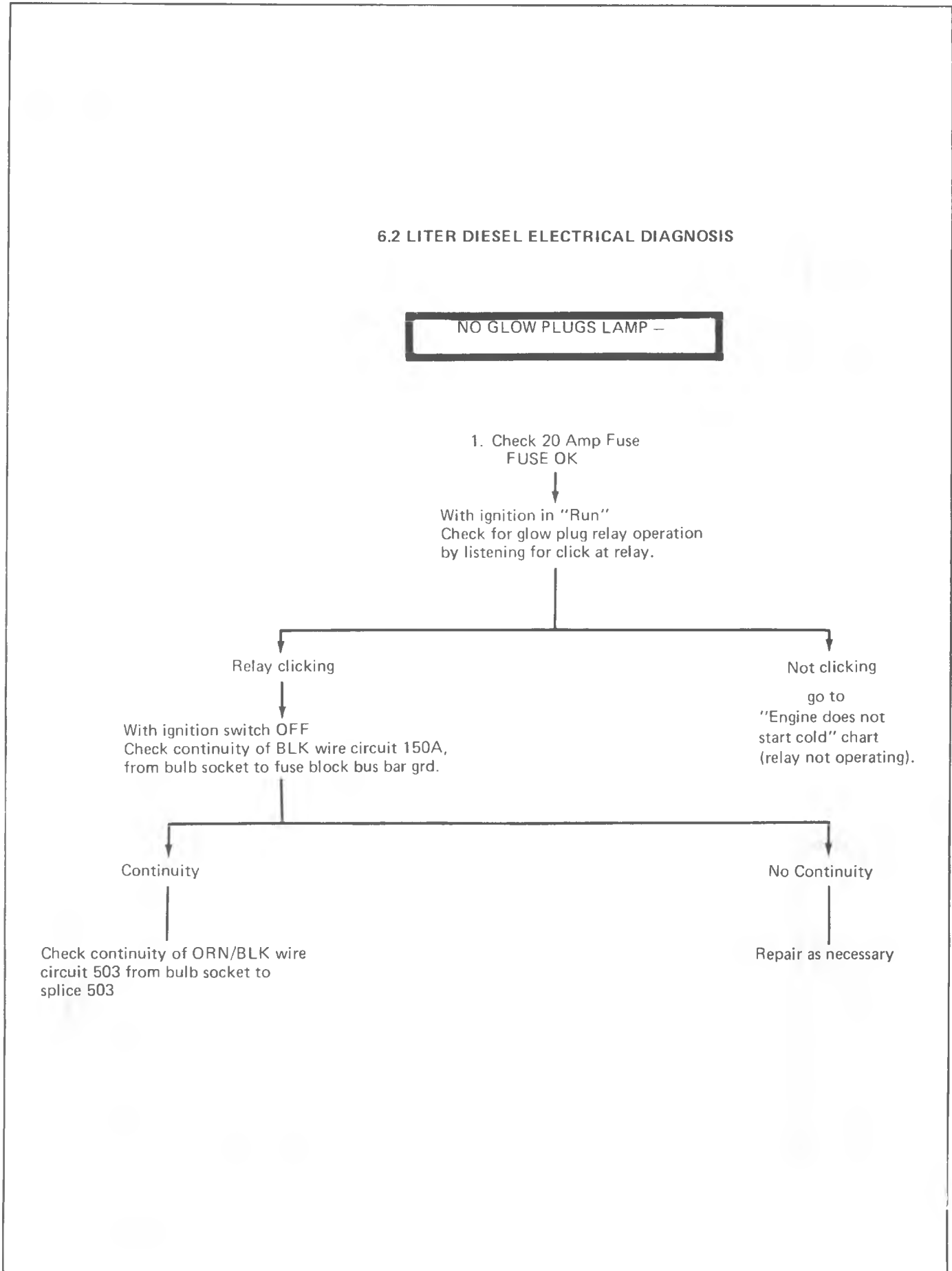

6.2 LITER DIESEL ELECTRICAL SYSTEM DIAGNOSIS

IF NEITHER FAST IDLE OR COLD ADVANCE SOLENOIDS OPERATE, CHECK FOR VOLTAGE AT COLD ADV/FAST IDLE TEMP. SW.

**NO FAST IDLE WITH COLD ENGINE (20 AMP FUSE OK) TEMPERATURE BELOW 90°F**

Turn ignition switch to run position and disconnect and connect fast idle solenoid. Check for solenoid operation.

SOLENOID OPERATES

Re-adjust for correct fast idle. See engine fuel section.

SOLENOID DOES NOT OPERATE

Use a 12-volt test light connected to ground and touch the disconnected light green wire at the solenoid connector.

TEST LIGHT OFF

Touch test light to lt. green wire in connector on cold advance/fast idle temp. sw.

TEST LIGHT ON

Check solenoid connector and ground. If OK, replace solenoid.

TEST LIGHT ON

Repair open lt. grn. wire from fast idle solenoid to cold advance solenoid or lt. grn. wire cold advance solenoid to temperature switch.

TEST LIGHT OFF

Touch test light to pnk/blk. wire on cold advance switch

TEST LIGHT ON

Replace cold advance temp. sw.

TEST LIGHT OFF

Locate and repair open circuit in pnk/blk wire

101079

**NO COLD ADVANCE COLD ENGINE**

Turn ignition switch to run position and disconnect and connect cold advance solenoid connector. Check for solenoid operation.

SOLENOID OPERATES

Problem is in fuel injection pump system refer to engine fuel section.

SOLENOID DOES NOT OPERATE

Use a 12-volt test light connected to ground and touch the disconnected light green wire at the solenoid connector.

TEST LIGHT OFF

Touch test light to lt. green wire in connector on cold advance/fast idle temp. sw.

TEST LIGHT ON

Check solenoid connector and ground. If OK, replace solenoid.

TEST LIGHT ON

Repair open lt. grn. wire from fast idle solenoid to cold advance solenoid or pnk/blk. wire cold advance solenoid to temperature switch.

TEST LIGHT OFF

Touch test light to lt. grn. wire on cold advance switch

TEST LIGHT ON

Replace cold advance temp. sw.

TEST LIGHT OFF

Locate and repair open circuit in pnk/blk wire

Fig. 6D-42--Diesel Glow Plug Simplified Wiring Diagram

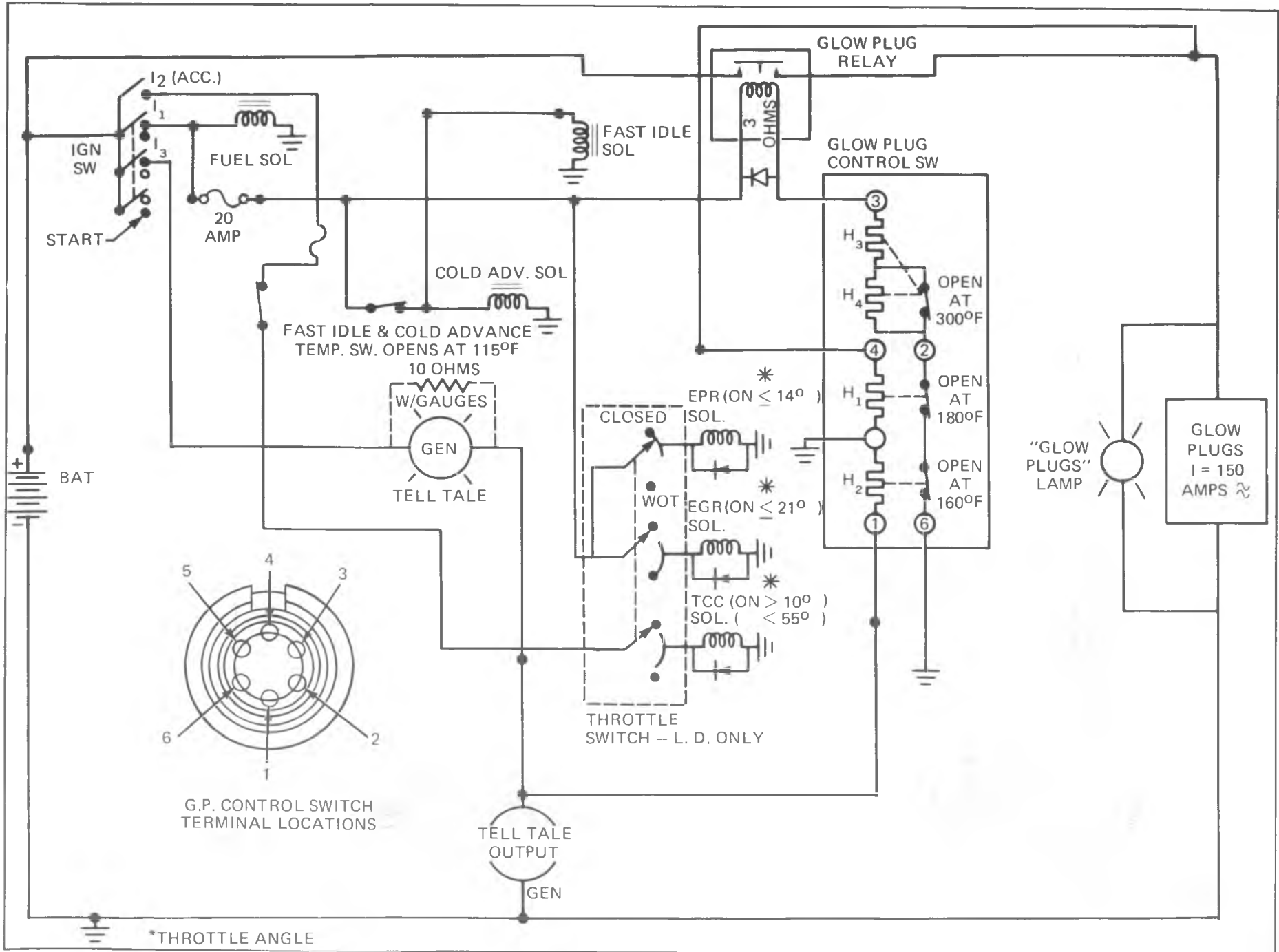

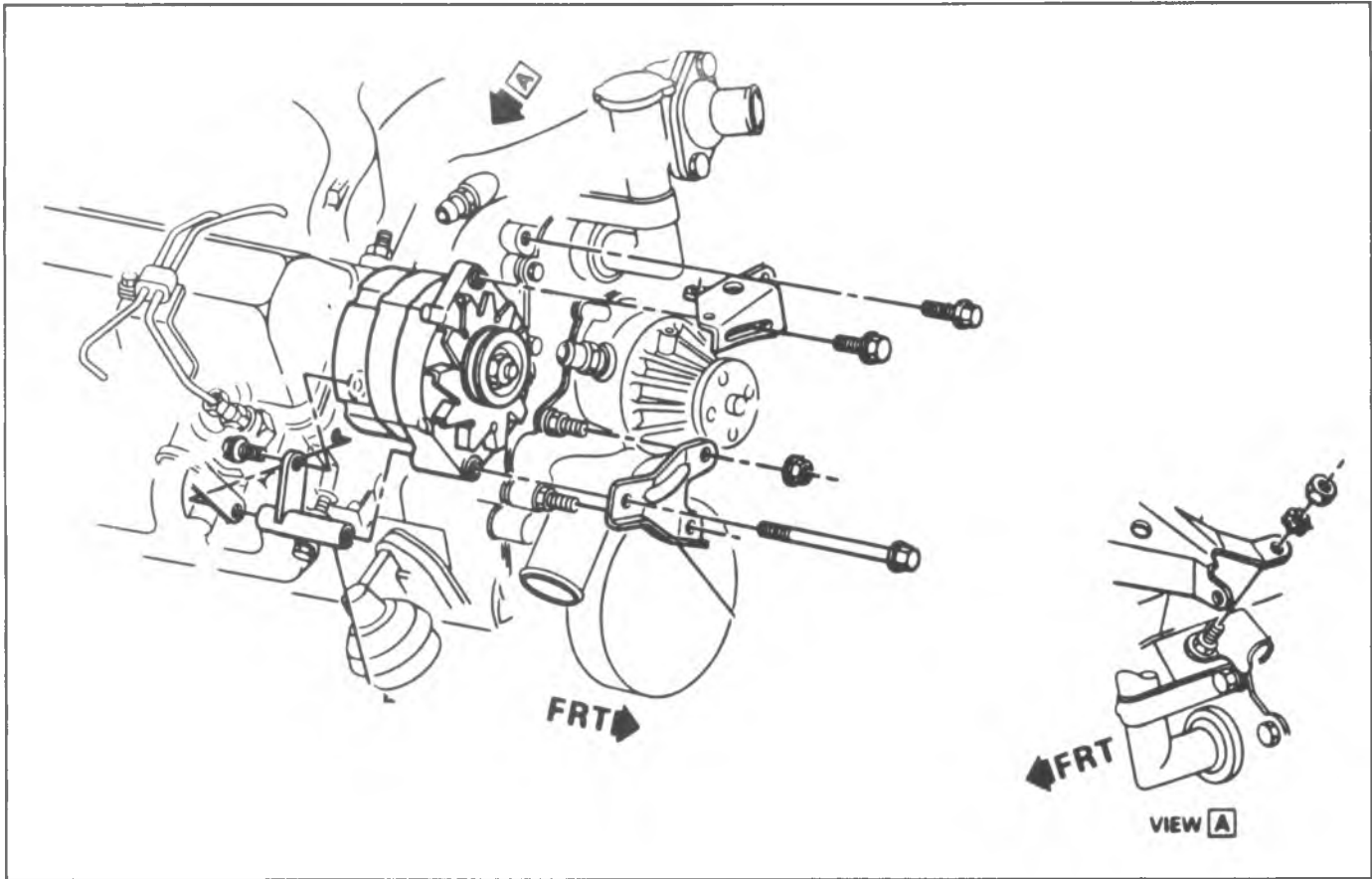

Fig. 6D-45--Generator Mounting - with A/C

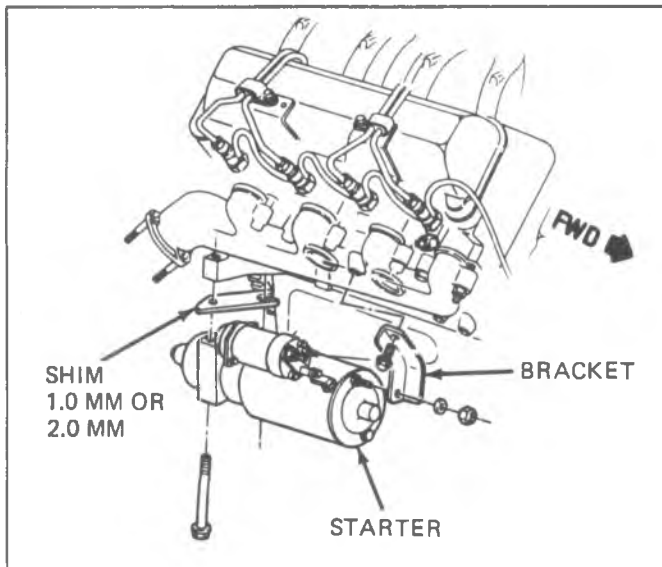

Fig. 6D-43--Diesel Starter Mounting

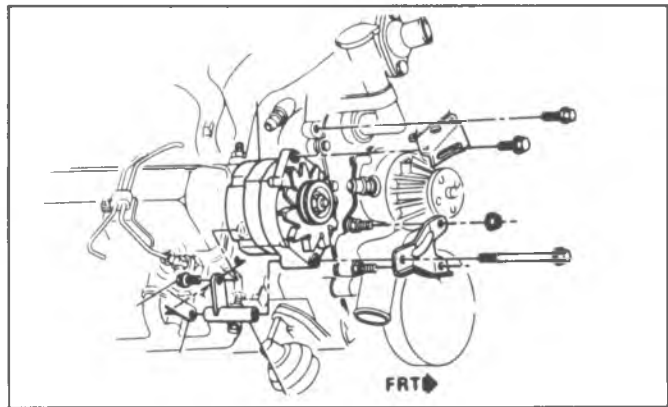
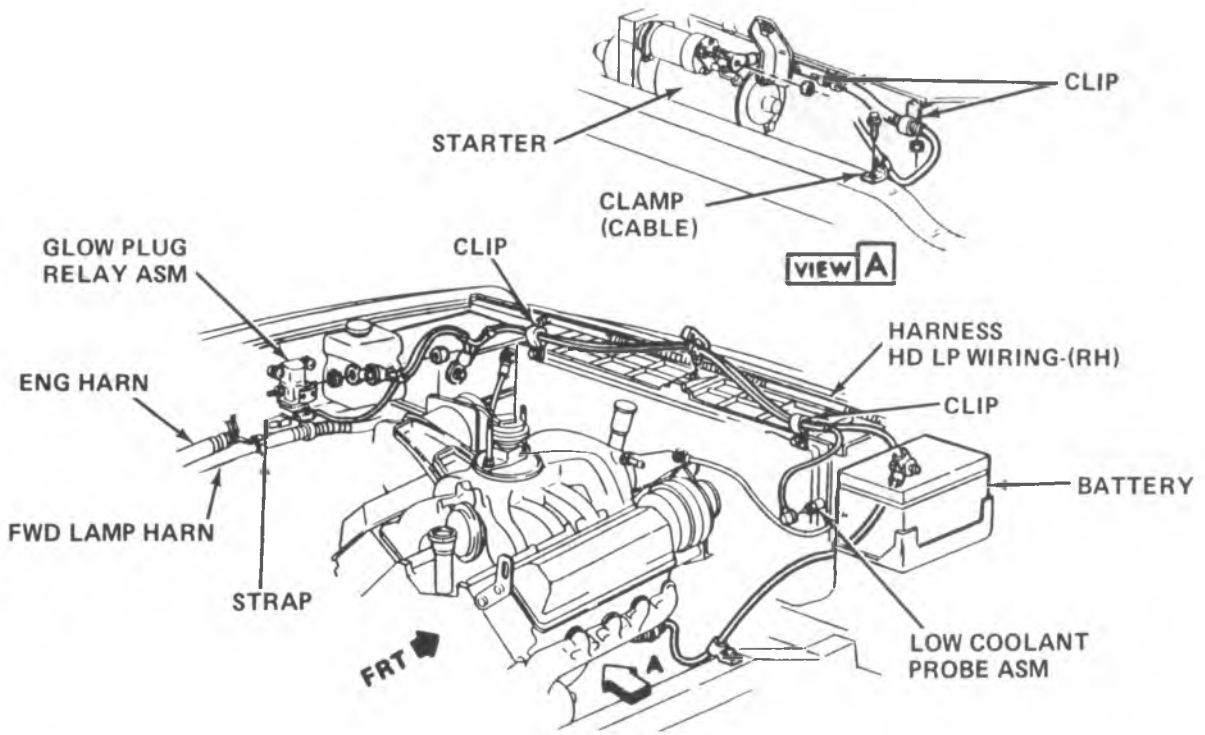

Fig. 6D-44--Generator Mounting



**BATTERY POSITIVE  
LEAD ROUTING**

**BATTERY  
NEGATIVE LEADS**

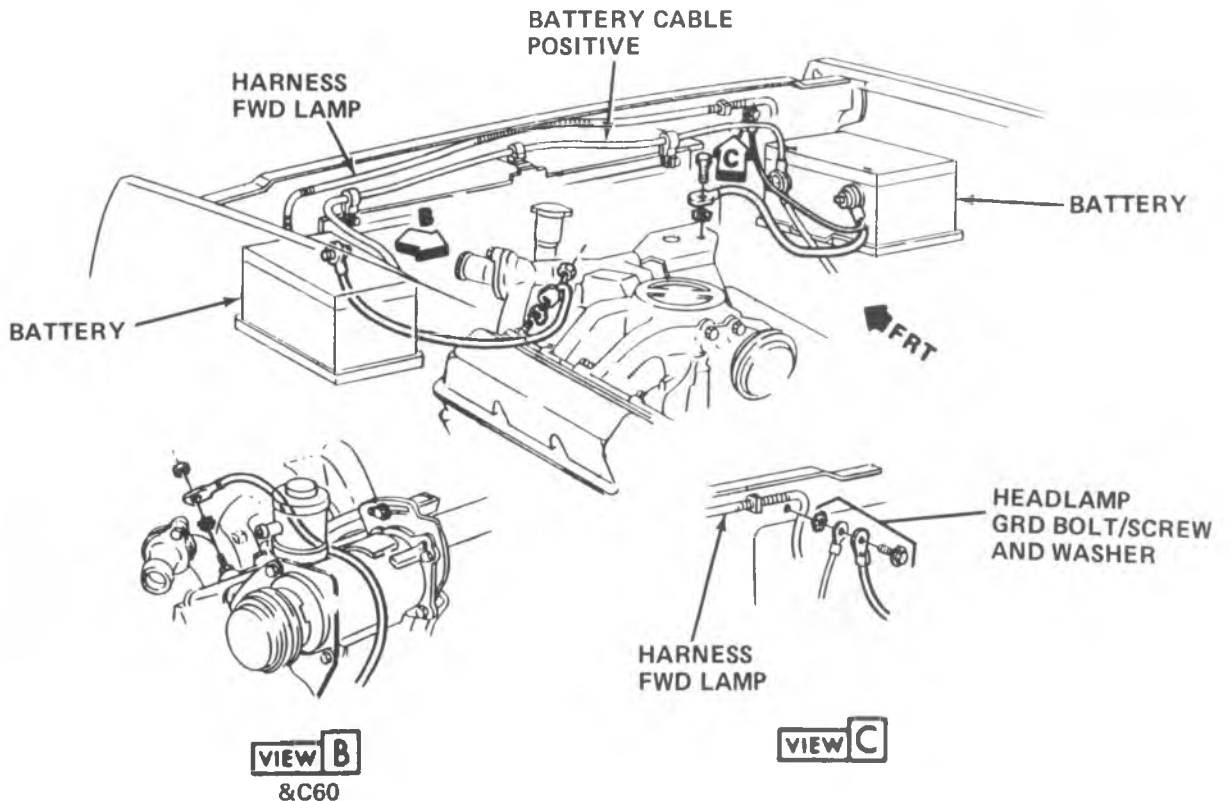

Fig. 6D-46--Battery and Leads



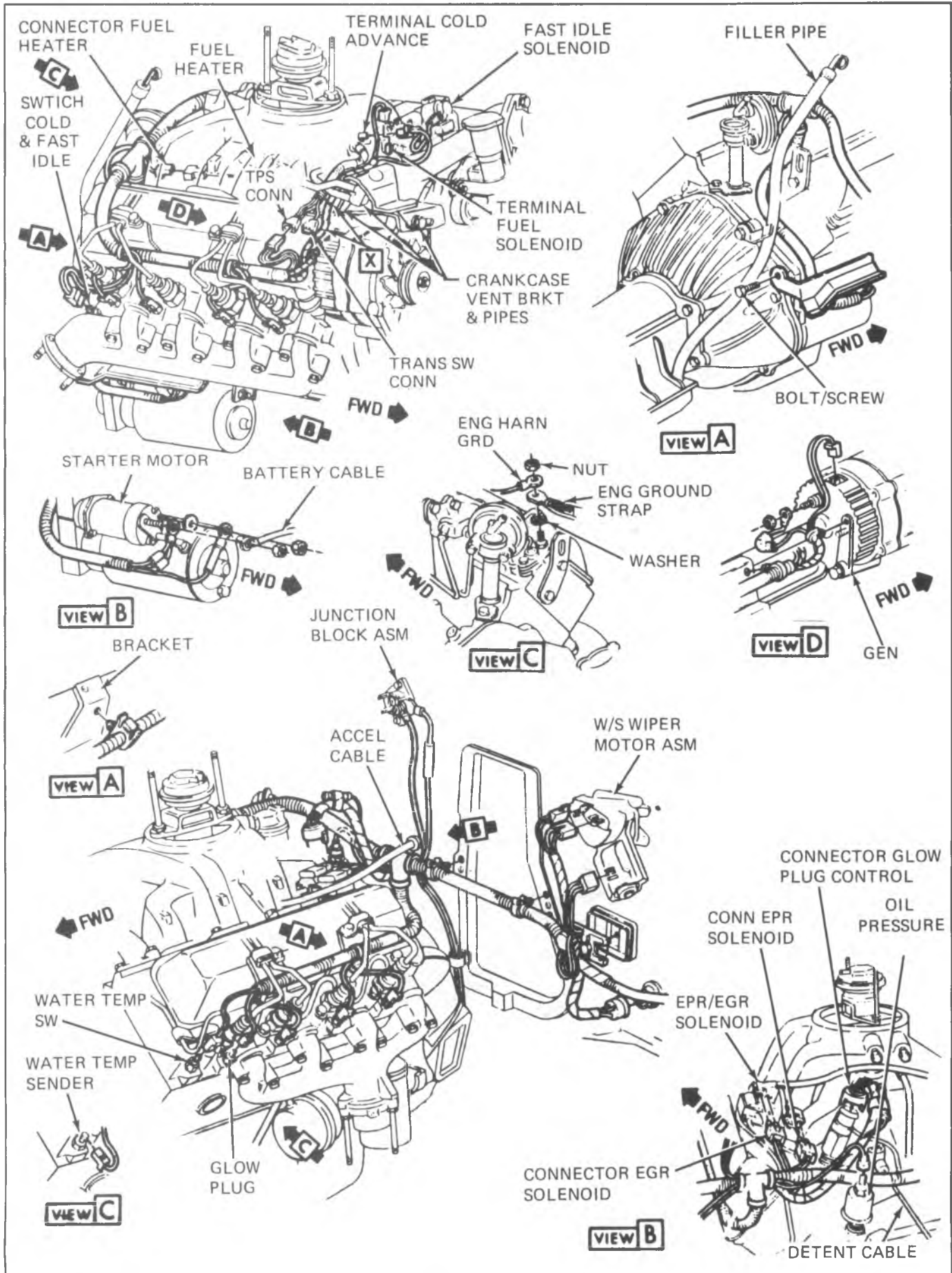

Fig. 6D-47--Engine Compartment Wiring-LH6

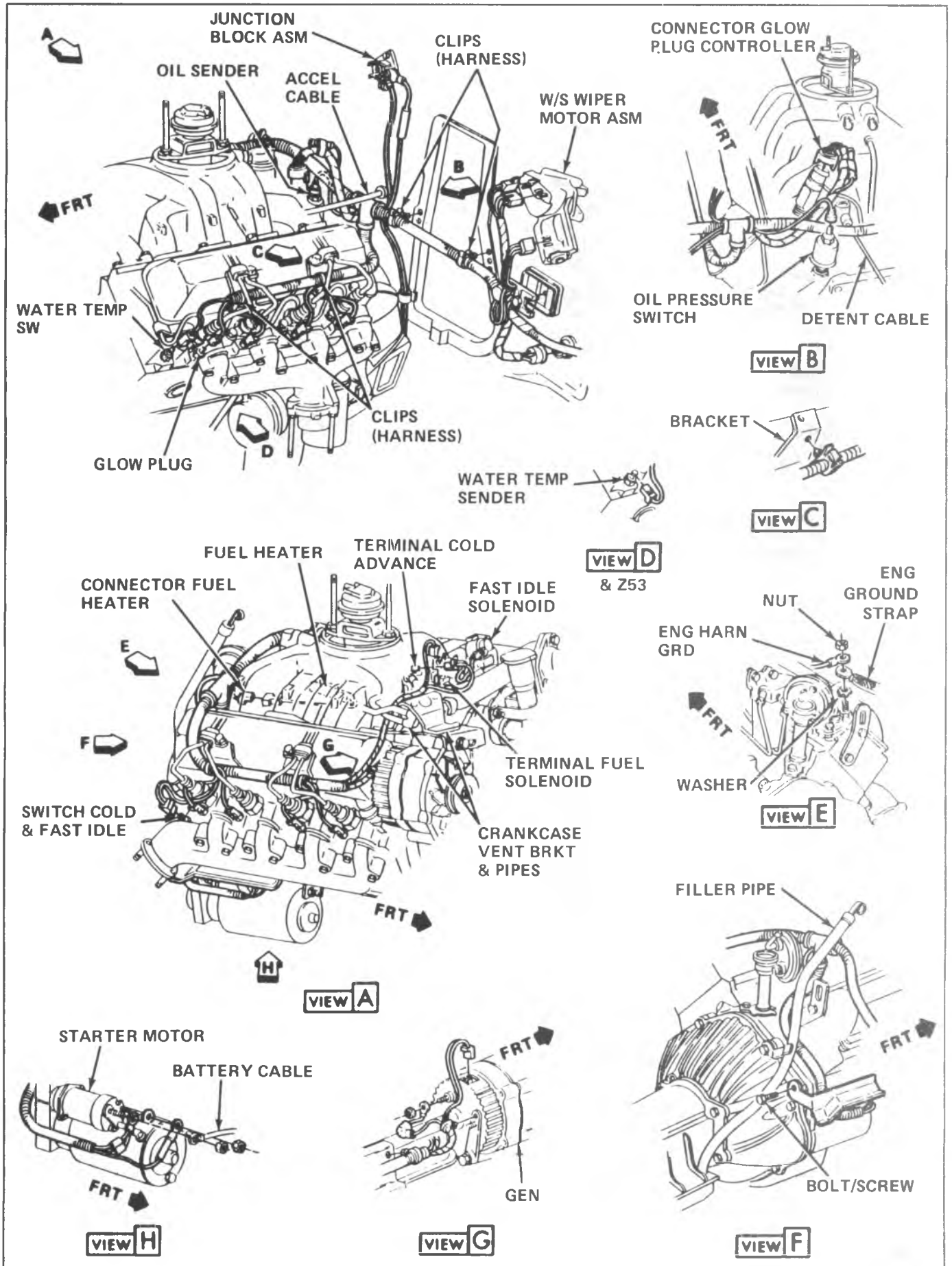

Fig. 6D-48-Engine Compartment Wiring-LL4

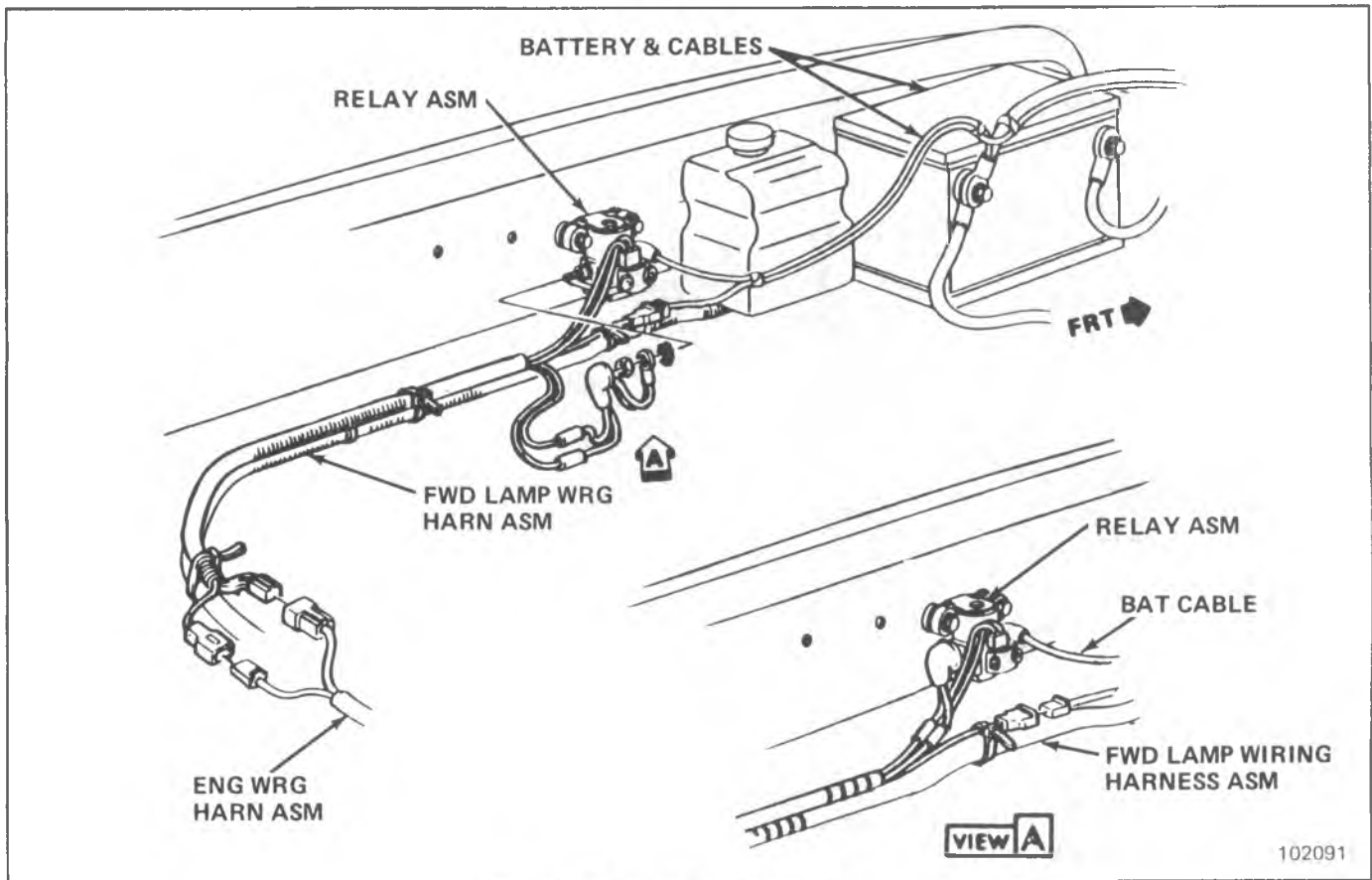

Fig. 6D-49--Diesel Engine Wiring-Relay

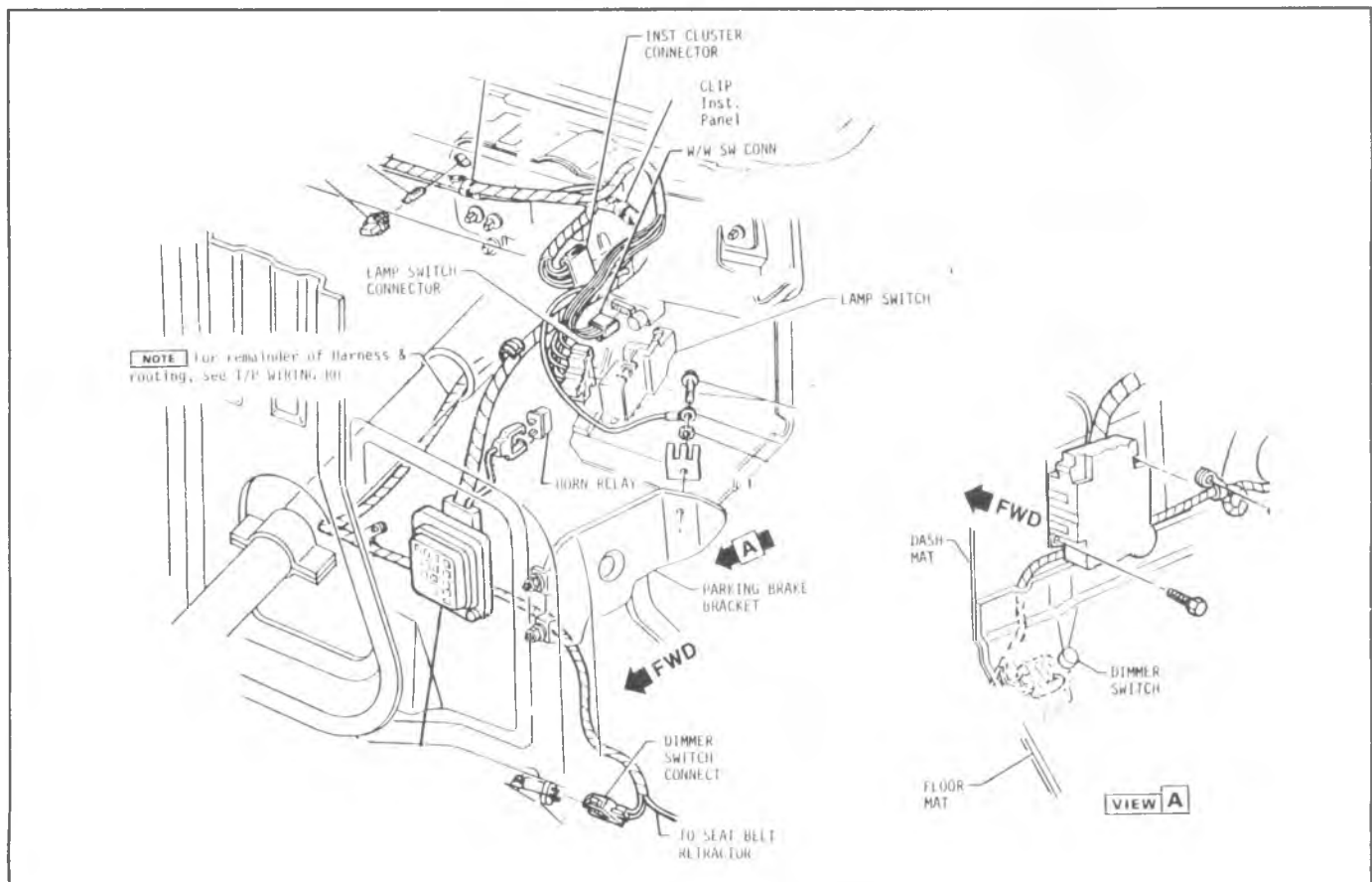

Fig. 6D-50--I.P. Wiring-Left Side and Bus Bar Grd

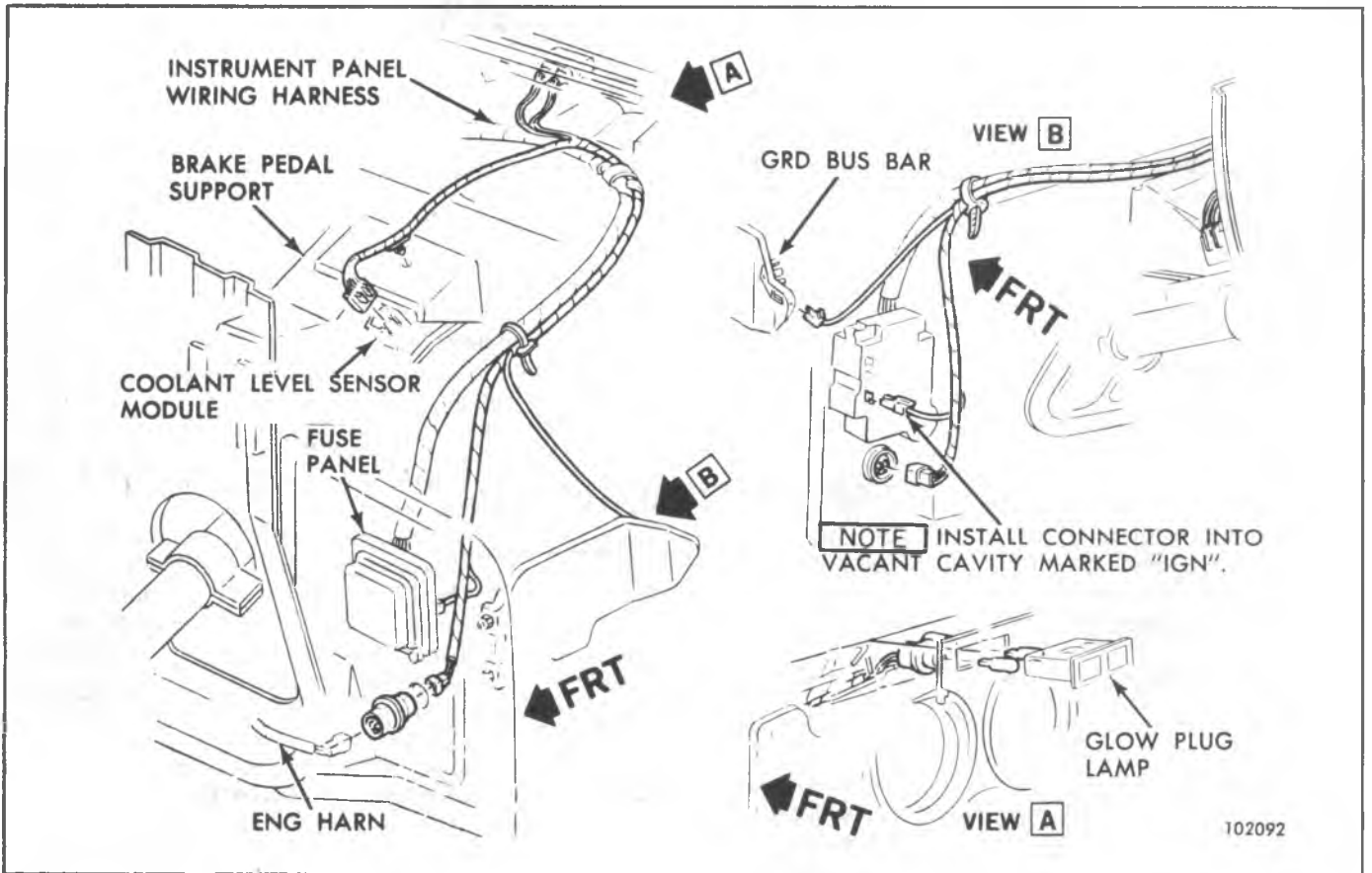

Fig. 6D-51--Glow Plug Lamp Wiring

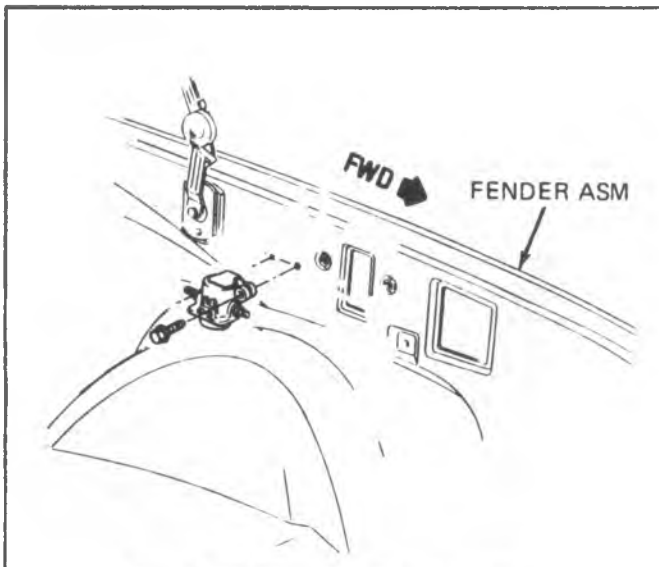

Fig. 6D-52--Glow Plug Relay Mounting

# IGNITION SYSTEM - GAS ENGINES

## CONTENTS

|                          |       |                             |       |
|--------------------------|-------|-----------------------------|-------|
| General Description..... | 6D-46 | Remove and Replace.....     | 6D-58 |
| H.E.I. Distributor.....  | 6D-46 | Distributor.....            | 6D-58 |
| Ignition Timing.....     | 6D-47 | Module.....                 | 6D-58 |
| Secondary Wiring.....    | 6D-47 | Pick-up Coil.....           | 6D-58 |
| Spark Plugs.....         | 6D-47 | Rotor.....                  | 6D-58 |
| Ignition Switch.....     | 6D-49 | Vacuum Advance Unit.....    | 6D-58 |
| Diagnosis.....           | 6D-49 | Integral Ignition Coil..... | 6D-58 |
| H.E.I. Distributor.....  | 6D-49 | Capacitor.....              | 6D-58 |
| On-Vehicle Service.....  | 6D-58 | Set Ignition Timing.....    | 6D-62 |
| H.E.I. Distributor.....  | 6D-58 | Spark Plug Wires.....       | 6D-62 |

## GENERAL DESCRIPTION

The ignition circuit consists of the battery, the distributor, the ignition switch, the spark plugs, and the primary and secondary wiring. Refer to the Battery portion of this section for battery information.

### H.E.I. DISTRIBUTOR

The High Energy Ignition distributor used on all engines combines all ignition components in one unit (Fig. 6D-53 and 6D-54). The external electrical connections are the ignition switch feed wire, the tachometer pickup, and the six or eight spark plug leads. The ignition switch feed connector to the distributor has full battery voltage when the ignition switch is in the "RUN" and "START" positions. There is **NO RESISTOR WIRE FROM THE IGNITION SWITCH TO THE DISTRIBUTOR**. The ignition coil is in the distributor cap and connects through a resistance brush to the rotor. The High Energy Ignition System is basically identical in operation to conventional ignition except the module and pick-up coil replace the contact points.

The High Energy Ignition is a magnetic pulse triggered, transistor controlled, inductive discharge ignition system. The magnetic pick-up assembly located inside the distributor contains a permanent magnet, a pole piece with internal teeth, and a pick-up coil. When the teeth of the timer core rotating inside the pole piece line up with the teeth of the pole piece, an induced voltage in the pick-up coil signals the electronic module to trigger the coil primary circuit. The primary current decreases and a high voltage is induced in the ignition coil secondary winding which is directed through the rotor and secondary leads to fire the spark plugs. The capacitor in the distributor is for radio noise suppression.

The magnetic pick-up assembly is mounted over the main bearing on the distributor housing, and is made to rotate by the vacuum control unit, thus providing vacuum advance. The timer core is made to rotate about the shaft by conventional advance weights, thus providing centrifugal advance.

The module automatically controls the dwell period, stretching it with increasing engine speed. The HEI system also features a longer spark duration, made possible by the higher amount of energy stored in the coil primary. This is desirable for firing lean mixtures.

*not mine*  
*Electr. Spark Timing*

Some engines use an HEI/EST distributor. All spark timing changes in the H.E.I. (EST) distributor are done electronically by the Electronic Control Module (ECM) which monitors information from various engine sensors, computes the desired spark timing and signals the distributor to change the timing accordingly. No vacuum or mechanical advance are used. Further EST information is found in Section 6E, Emissions.

### Electronic Spark Control

*mine!*

An additional electronic control (ESC) is used on vehicles equipped with an LE9 engine. The Electronic Spark Control (ESC) system is a closed loop system that controls engine detonation by modifying the spark advance when detonation occurs, after which the spark control will revert to EST. The amount of retard is a function of the degree of detonation.

There are two basic components in this system as outlined below.

#### Controller. (Fig. 6D-55)

The (ESC) controller processes the sensor signal and applies it to the distributor to adjust spark timing. The process is continuous so that the presence of detonation is monitored and controlled. The controller is a hard wired signal processor/amplifier which operates from 6 to 16 volts. The controller has no memory storage.

#### Sensor (Fig. 6D-55)

The (ESC) sensor is a piezoelectric device, mounted in the engine block that detects the presence (or absence) and intensity of detonation by the vibration characteristics of the engine. The output is an electrical signal that goes to the controller. A sensor failure would allow no retard.

#### ESC Vacuum Switch See (Fig. 6D-56)

On LE9 engine equipped vehicles with automatic transmission a "tip in" vacuum switch is used. Its function is to provide a momentary contact closure (signal) to the ESC controller during a throttle "tip in" condition which then briefly retards spark timing to minimize knock.

The switch contacts are normally open under steady engine vacuum conditions including no vacuum, and all brief increasing vacuum conditions. Basically the switch closes only during rapidly decreasing vacuum conditions such as that encountered on rapid throttle operation.

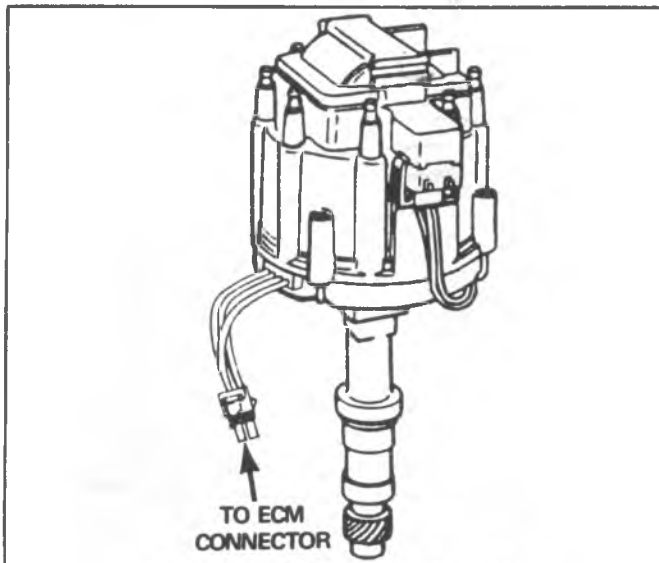

Fig. 6D-53--HEI Distributor Assembly

When making compression checks, disconnect ignition switch connector (pink wire) from HEI system.

No periodic lubrication is required. Engine oil lubricates the lower bushing and an oil-filled reservoir provides lubrication for the upper bushing.

### IGNITION TIMING

Timing specifications for each engine are listed in Section 6E and on the Vehicle Emissions Control Information label on the radiator support. When using a timing light, connect an adapter between the No. 1 spark plug and the No. 1 spark plug wire, or use an inductive type pick-up. Do not pierce the plug lead. Once the insulation of the spark plug cable has been broken, voltage will jump to the nearest ground, and the spark plug will not fire properly. The timing procedure remains the same as the conventional ignition system. Always follow Vehicle Emissions Control Information label procedures when adjusting timing.

Some engines will incorporate a magnetic timing probe hole for use with special electronic timing equipment. Consult manufacturer's instructions for use of this equipment.

### SECONDARY WIRING

The spark plug wiring used with the HEI system is a carbon impregnated cord conductor encased in an 8mm diameter silicone rubber jacket. The silicone wiring will withstand very high temperatures and also provides an excellent insulator for the higher voltage of the HEI system. The silicone spark plug boots form a tight seal on the plug and the boot should be twisted 1/2 turn before removing. Care should also be exercised when connecting a timing light or other pick-up equipment. Do not force contacts between the boot and wiring or through the silicone jacket. Connections should be made in parallel using an adapter. DO NOT pull on the wire to remove. Pull on the boot, or use a tool designed for this purpose.

### SPARK PLUGS (FIG. 6D-57)

Resistor type, tapered seat spark plugs are used on all gasoline engines. No gasket is used on these tapered seat plugs. See Fig. 6D-58 for an explanation of letter coding on spark plugs.

See Engine Exhaust Emissions Section (6E) for spark plug application and gap sizes. Always replace plugs with the correct plug listed on the Vehicle Emissions Control Information label.

Normal or average service is assumed to be a mixture of idling, slow speed, and high speed operation with some of each making up the daily total driving. Occasional or intermittent high-speed driving is essential to good spark plug performance as it provides increased and sustained combustion heat that burns away any excess deposits of carbon or oxide that may have accumulated from frequent idling or continual stop-and-go or slow-speed driving. Spark plugs are protected by an insulating nipple made of special heat-resistant material which covers the spark plug terminal and extends downward over a portion of the plug insulator. These nipples prevent flash-over with resultant missing of

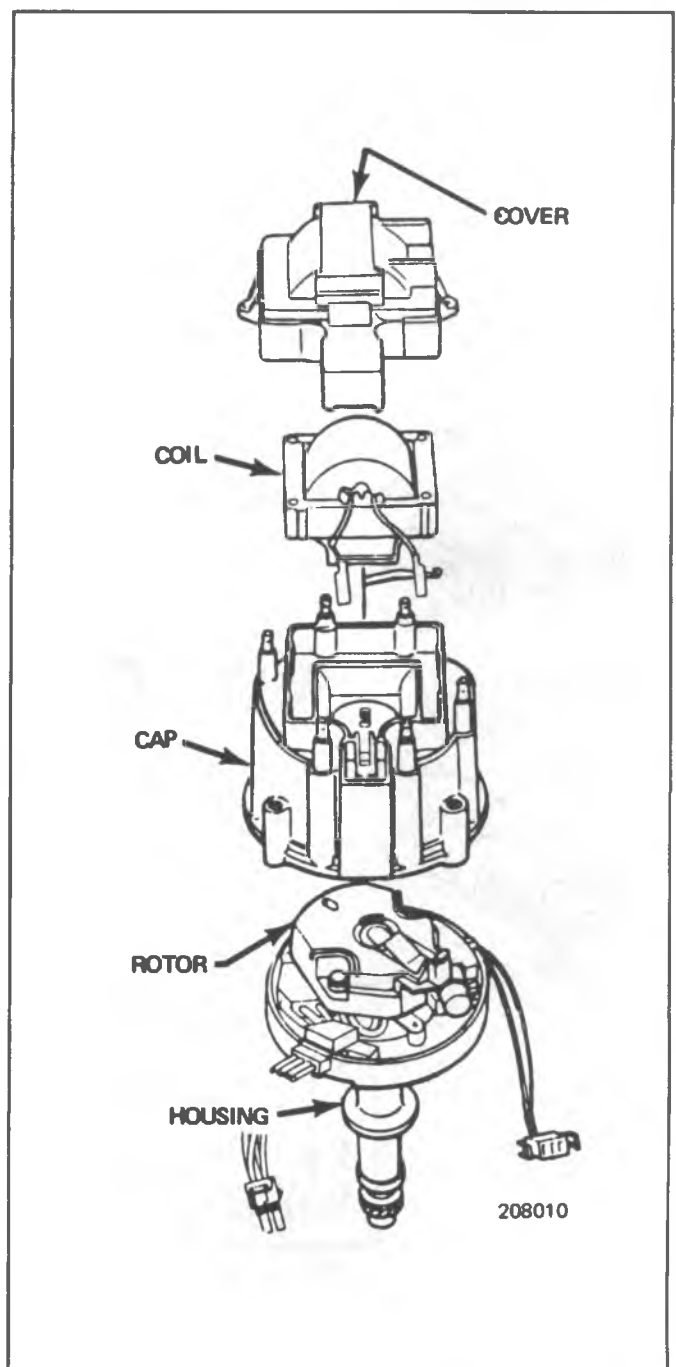

Fig. 6D-54--HEI Distributor - Exploded View



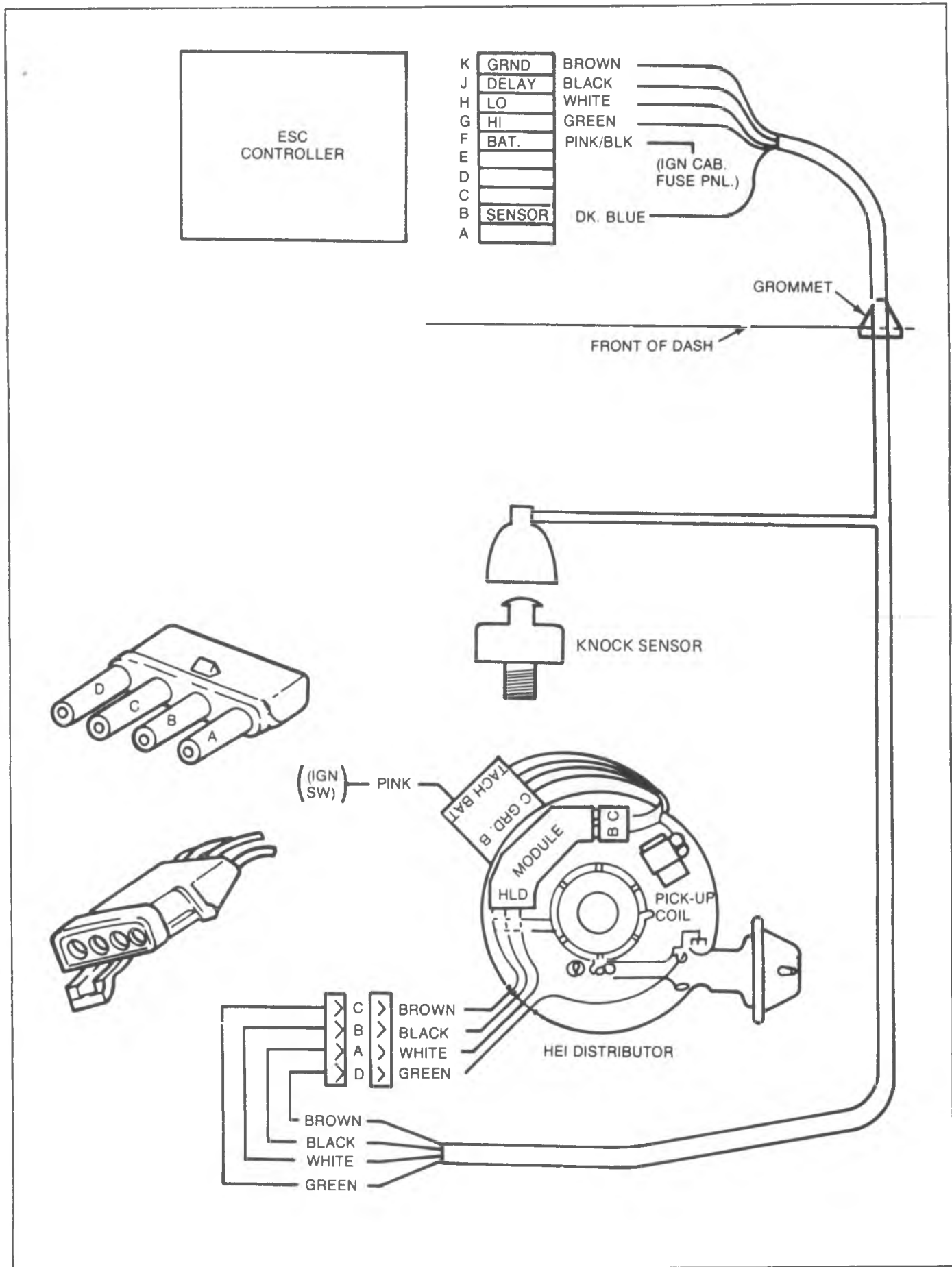

Fig. 6D-55--ESC Controller, Sensor and Wiring

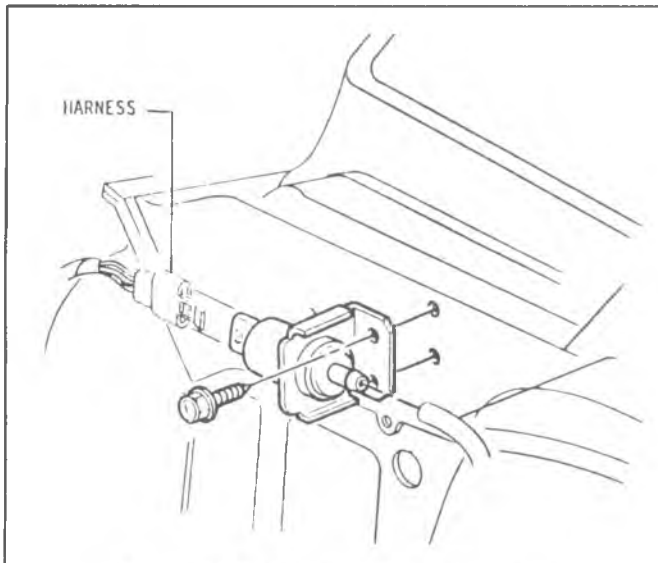

Fig. 6D-56-ESC Vacuum Switch Mounting

engine, even though a film is allowed to accumulate on exposed portion of plug porcelains.

Do not mistake corona discharge for flash-over or a shorted insulator. Corona is a steady blue light appearing around insulator, just above the shell crimp. It is the visible evidence of high-tension field, and has no effect on ignition performance. Usually it can be detected only in darkness. This discharge may repel dust particles, leaving a clear ring on the insulator just above the shell. This ring

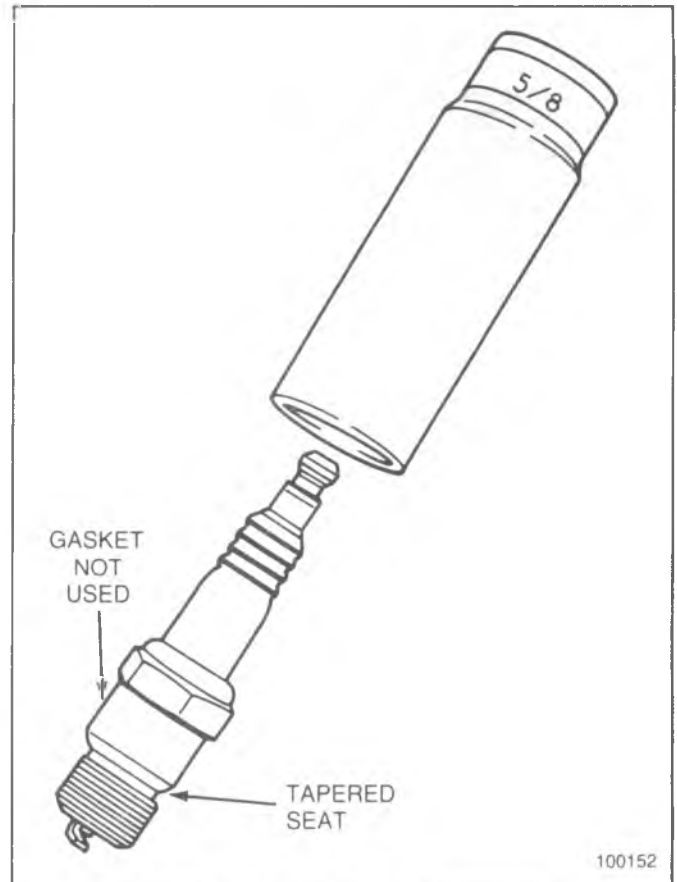

Fig. 6D-57-Spark Plug - Tapered Seat

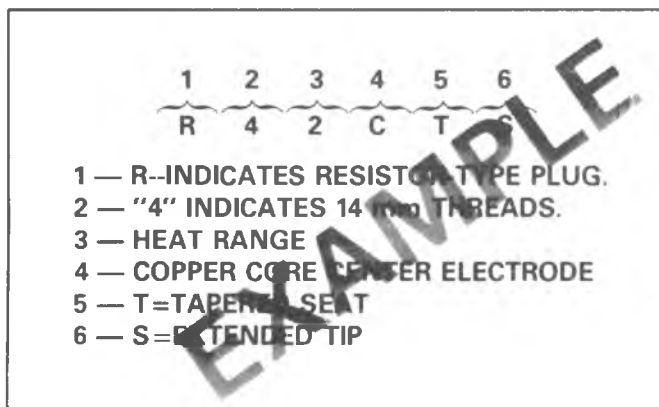

Fig. 6D-58--Spark Plug Coding

is sometimes mistakenly regarded as evidence that combustion gases have blown out between shell and insulator.

### IGNITION SWITCH

The mechanical switch is located in the steering column on the right hand side just below the steering wheel. The electrical switching portion of the assembly is separate from the key and lock cylinder. However, both are synchronized and work in conjunction with each other through the action of the actuator rod assembly.

For a complete explanation of the key and lock cylinder, and the actuator rod assembly, see STEERING, Section 3B. See Section 8 for the detailed explanation of the electrical switching.

## DIAGNOSIS

### H.E.I. DISTRIBUTOR

Use Figure 6D-59 and 60 for H.E.I. Diagnosis.

### SPARK PLUGS

Worn or dirty plugs may give satisfactory operation at idling speed, but under operating conditions they frequently fail. Faulty plugs are indicated in a number of ways: poor fuel economy, power loss, loss of speed, hard starting and general poor engine performance.

Spark plug failure, in addition to normal wear, may be due to carbon fouled plugs, excessive gap or broken insulator.

Fouled plugs may be indicated by checking for black carbon deposits. The black deposits are usually the result of slow-speed driving and short runs where sufficient engine operating temperature is seldom reached. Worn pistons, rings, faulty ignition, over-rich carburetion and spark plugs which are too cold will also result in carbon deposits.

Excessive gap wear, on plugs of low mileage, usually indicates the engine is operating at high speeds or loads that are consistently greater than normal or that a plug which is too hot is being used. In addition, electrode wear may be the result of plug overheating, caused by combustion gases leaking past the threads, due to insufficient torquing of the spark plug. Excessively lean carburetion will also



result in excessive electrode wear.

Broken insulators are usually the result of improper installation or carelessness when regapping the plug. Broken upper insulators usually result from a poor fitting wrench or an outside blow. The cracked insulator may not make itself evident immediately, but will as soon as oil or moisture penetrates the fracture. The fracture is usually just below the crimped part of shell and may not be visible.

Broken lower insulators usually result from carelessness when regapping and generally are visible. In fairly rare instances, this type of break may result from the plug operating too "hot", encountered in sustained periods of high-speed operation or under extremely heavy loads. When regapping a spark plug, to avoid lower insulator breakage, always make the gap adjustment by bending the ground (side) electrode. Spark plugs with broken insulators should always be replaced.

**PRELIMINARY**  
**1983 CCC**  
**ENGINE CRANKS, BUT WILL NOT RUN**  
**(WITH INTEGRAL IGNITION COIL)**

**NOTE:** Perform Diagnostic Circuit Check before using this procedure.  
 If a tachometer is connected to the tachometer terminal, disconnect it before proceeding with the test.  
 Intermittent no start may be caused by wrong pick-up or ignition coil.

**1. Check spark at plug with ST-125 while cranking (if no spark on one wire, check a second wire). \***

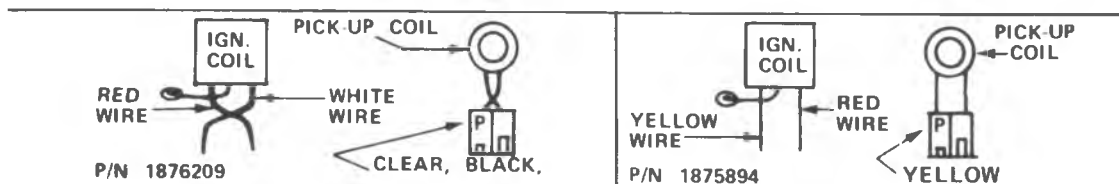
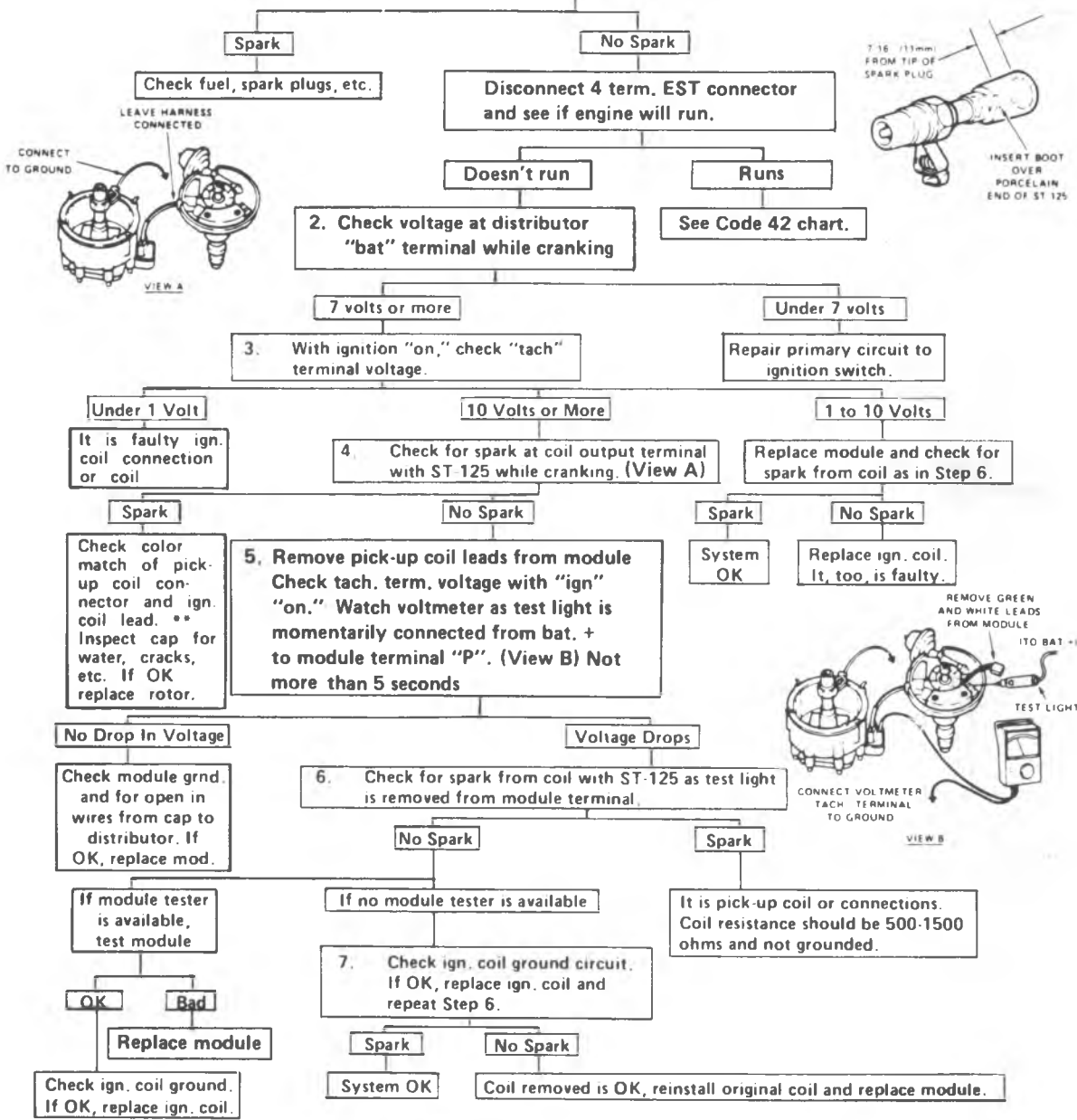

\* A few sparks and then nothing, is considered no spark.

Fig. 6D-59-HEI Diagnosis

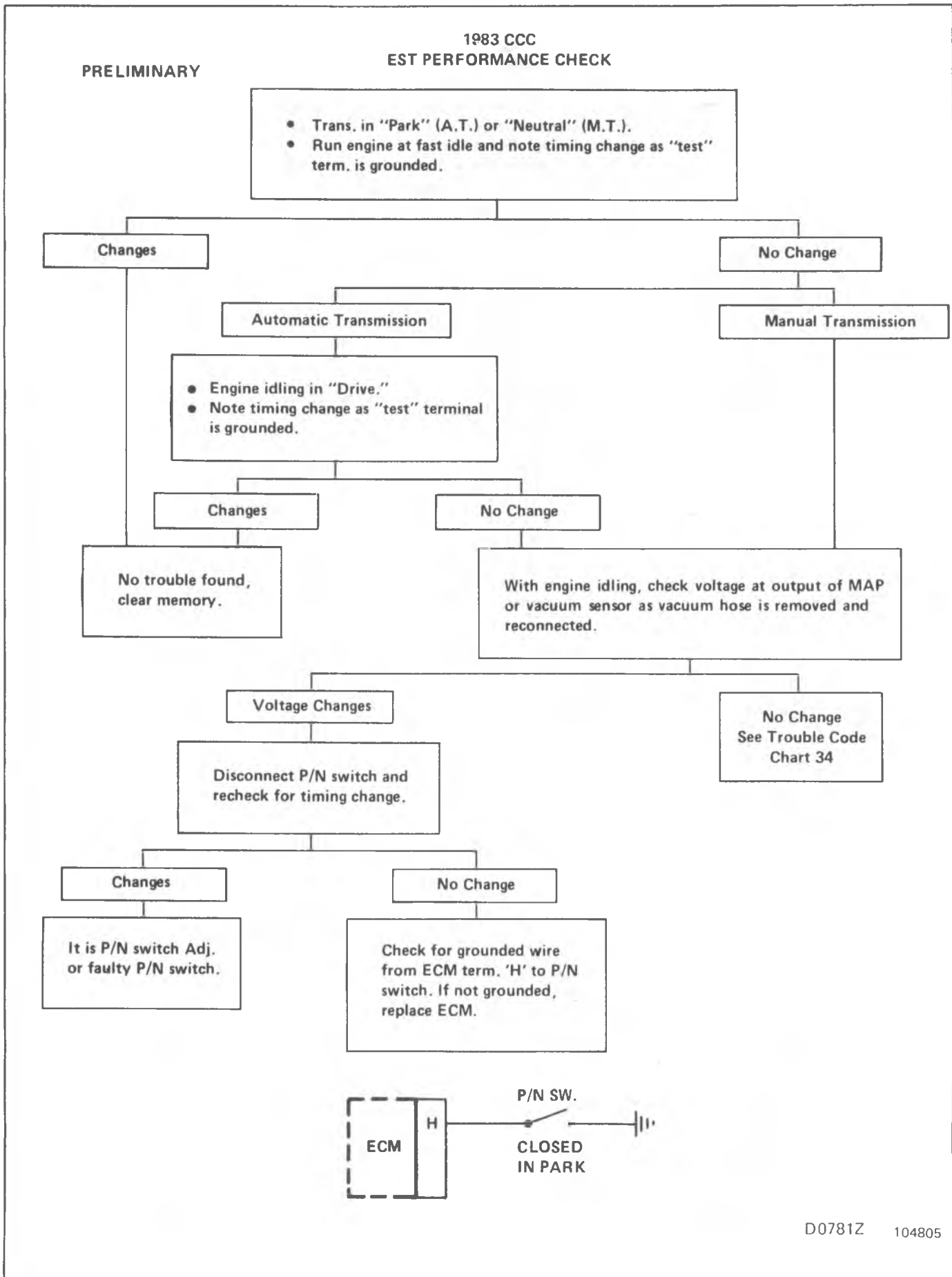

Fig. 6D-60--HEI Diagnosis

ENGINE DETONATION ①

CHEVROLET LIGHT TRUCK  
ESC SYSTEM DIAGNOSIS

BEFORE ATTEMPTING ANY  
DIAGNOSIS, CHECK CONNECTION  
AT SENSOR AND INSURE  
THAT ALL CONNECTIONS ARE  
CLEAN AND TIGHT

WITH ENGINE RUNNING AT FAST IDLE SPEED & TRANS.  
IN N OR P (ENGINE SPEED ABOVE 1000 RPM), TAP  
EXHAUST MANIFOLD LIGHTLY & REPEATEDLY &  
CHECK FOR SPARK TIMING RETARD (WITH TIMING  
LIGHT).

RETARD

CHECK OTHER "ENGINE  
DETONATION" CAUSES

NO RETARD

DISCONNECT 10-PIN CONNECTOR FROM ESC CON-  
TROLLER. MEASURE VOLTAGE FROM PIN B TO  
PIN K IN CONNECTOR WITH ENGINE OPERATING  
AT APPROX. 2000 RPM. VOLTAGE SHOULD BE  
GREATER THAN 80 MILLIVOLTS, (.08 VOLTS)

LOW

DISCONNECT SENSOR WIRE FROM SENSOR. MEA-  
SURE VOLTAGE FROM SENSOR TERMINAL TO  
GROUND. SHOULD BE GREATER THAN 80 MILLI-  
VOLTS (.08 VOLTS) WITH ENGINE OPERATING  
AT APPROX 2000 RPM.

OK

TRY TO START ENGINE (WITH 10-PIN CONNECTOR  
DISCONNECTED).

OK

CHECK WIRES FROM PINS  
A, B, & K (IN 10-PIN  
CONNECTOR) FOR OPEN  
& SHORT CIRCUITS.

HIGH  
OR LOW

REPLACE SENSOR.

NO START

START

REPLACE DISTRIBUTOR  
MODULE.

OK

REPAIR SENSOR  
CONNECTOR.

NOT OK

REPAIR HARNESS.

RECONNECT 10-PIN CONNECTOR TO CONTROLLER.  
DISCONNECT SENSOR WIRE FROM SENSOR & INSERT  
A JUMPER WIRE INTO SENSOR WIRE CONNECTOR.  
WITH ENGINE RUNNING AT FAST IDLE SPEED, LAY WIRE  
ON TOP OF DISTRIBUTOR OVER IGNITION COIL &  
CHECK FOR SPARK TIMING RETARD.

RETARD

REPLACE SENSOR.

NO RETARD

MEASURE VOLTAGE FROM PIN H TO PIN K WITH  
IGNITION SWITCH ON. SHOULD BE MORE THAN  
0.2 VOLT.

OK

REPLACE ESC  
CONTROLLER.

NOT OK

REPAIR OPEN CIRCUIT IN WIRE  
FROM PIN H IN ESC HARNESS.

① SOME OCCASIONAL TRACE-TO-LIGHT DETONATION IS ACCEPTABLE

### CHEVROLET LIGHT TRUCK ESC SYSTEM DIAGNOSIS

POOR ENGINE PERFORMANCE. ①

DISCONNECT 4-PIN CONNECTOR AT DISTRIBUTOR & JUMPER PINS A & C IN DISTRIBUTOR CONNECTOR TOGETHER.

TROUBLE REMAINS

CHECK OTHER "POOR ENGINE PERFORMANCE" CAUSES

TROUBLE GONE

REMOVE JUMPER & RECONNECT 4-PIN CONNECTOR. JUMPER PINS A & K ON 10-PIN CONNECTOR AT ESC CONTROLLER WITHOUT DISCONNECTING CONNECTOR.

TROUBLE GONE

CHECK VOLTAGE (SEE ENGINE DETONATION) TO INSURE HARNESS IS OK.

TROUBLE REMAINS

OK

REMOVE JUMPER. WITH ENGINE RUNNING CHECK VOLTAGE FROM PIN F TO PIN K ON 10-PIN CONNECTOR.

CHECK FOR ENGINE NOISES (OTHER THAN DETONATION) CAUSING INPUT TO SENSOR, OR SUBSTITUTE WITH KNOWN GOOD SENSOR.

OVER 11.6 VOLTS

UNDER 11.6 VOLTS

CHECK WIRES IN ESC HARNESS FROM PINS H & K FOR PROPER CONNECTIONS & FOR OPEN CIRCUITS.

REPAIR ALTERNATOR CHARGING CIRCUIT.

DISCONNECT SENSOR WIRE FROM SENSOR. MEASURE VOLTAGE FROM SENSOR TERMINAL TO GROUND. (SEE ENGINE DETONATION.)

OK

HIGH OR LOW

OK

NOT OK

CHECK SENSOR WIRE FOR AN OPEN CIRCUIT.

REPLACE SENSOR

REPLACE ESC CONTROLLER.

REPAIR HARNESS.

OK

NOT OK

REPAIR SENSOR CONNECTOR.

REPAIR HARNESS.

## CHEVROLET LIGHT TRUCK ESC SYSTEM DIAGNOSIS

ENGINE CRANKS BUT DOES NOT START. ①

CHECK ESC HARNESS FOR PROPER CONNECTIONS.  
1. 10-PIN CONNECTOR TO ESC CONTROLLER.  
2. 4-PIN CONNECTOR TO DISTRIBUTOR.  
3. 2-BLADE MALE CONNECTOR TO DISTRIBUTOR.  
4. 2-BLADE FEMALE CONNECTOR TO IGNITION SWITCH LEAD (PINK WIRE).

NOT OK

REPAIR CONNECTIONS.

OK

DISCONNECT 4-PIN CONNECTOR AT DISTRIBUTOR & JUMPER PINS A & C IN DISTRIBUTOR CONNECTOR TOGETHER.

NO START

CHECK OTHER "ENGINE CRANKS BUT DOES NOT START" CAUSES.

START

REMOVE JUMPER & RECONNECT 4-PIN CONNECTOR TO DISTRIBUTOR. WITH IGNITION ON, CHECK VOLTAGE FROM PIN F TO PIN K ON 10-PIN CONNECTOR AT ESC CONTROLLER.

UNDER 7.0 VOLTS

REPAIR CIRCUIT BETWEEN IGNITION SWITCH & PIN F.

OVER 7.0 VOLTS

CHECK WIRES IN ESC HARNESS FROM PINS G, H, J, & K (IN 10-PIN CONNECTOR) FOR OPEN & SHORT CIRCUITS.

NOT OK

REPAIR HARNESS.

OK

REPLACE ESC CONTROLLER.

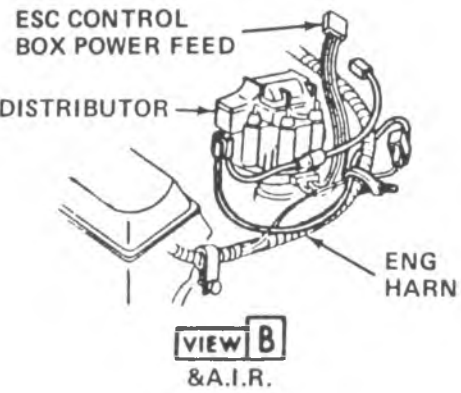
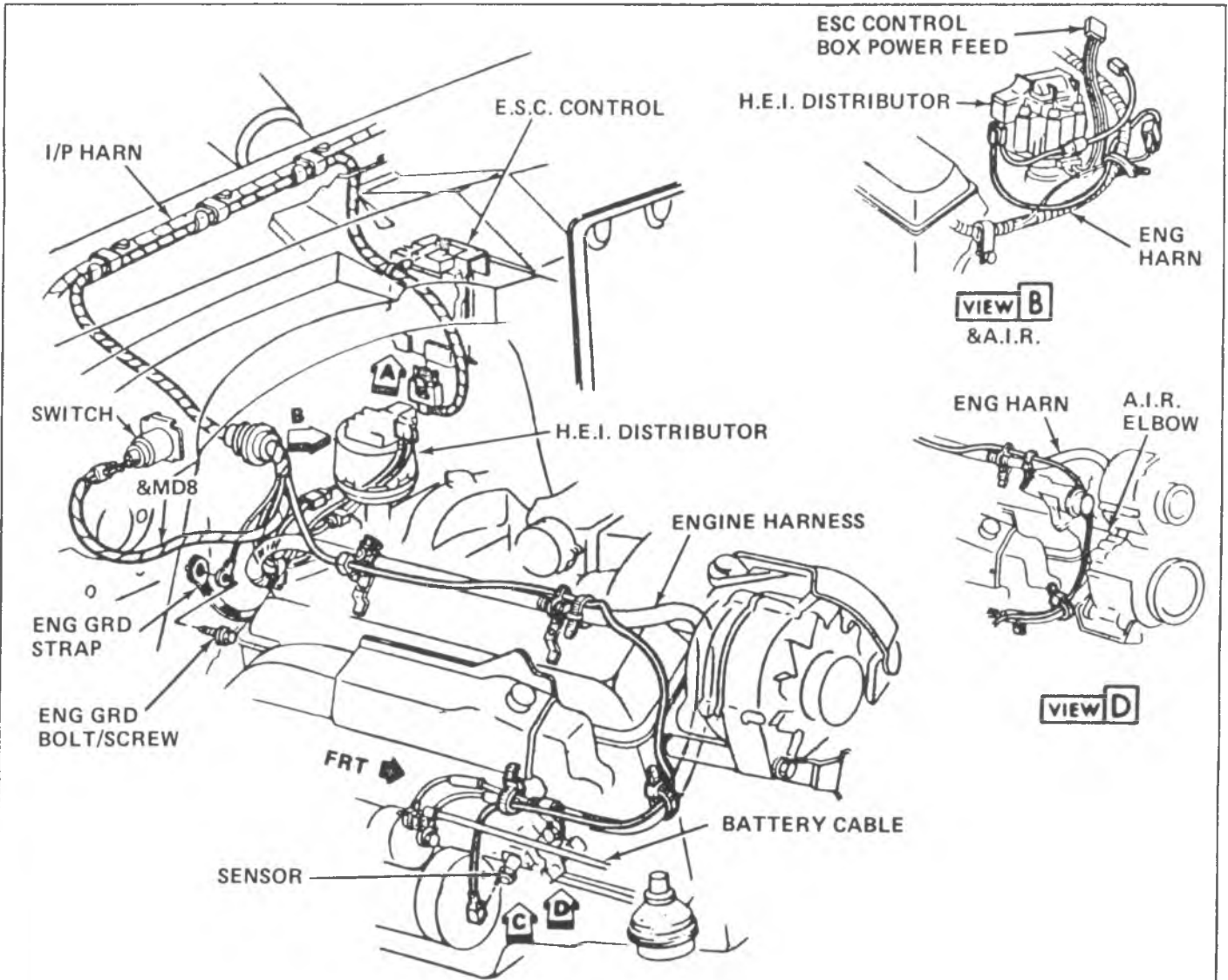

AFTER, DETONATION SENSOR CONNECTOR IS INSTALLED, APPLY A NOMINAL 3 LB. (1.4 Kg) REMOVAL FORCE TO THE CONNECTOR (NOT TO THE WIRE) TO ENSURE THAT IT IS LATCHED TO THE KNOCK SENSOR. THEN APPLY A 5 TO 10 LB. (2.3 TO 4.6 Kg) PUSH-ON FORCE TO GUARANTEE THAT THE CONNECTOR IS FULLY SEATED.

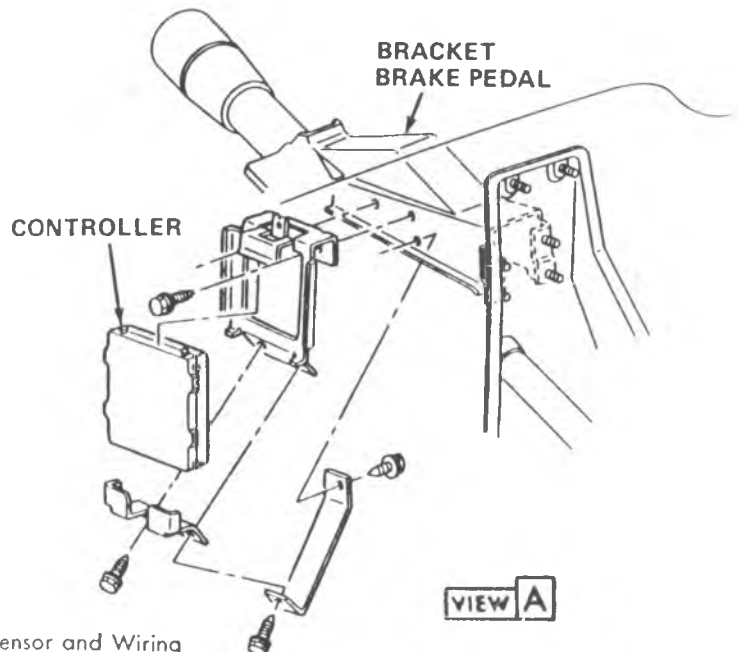
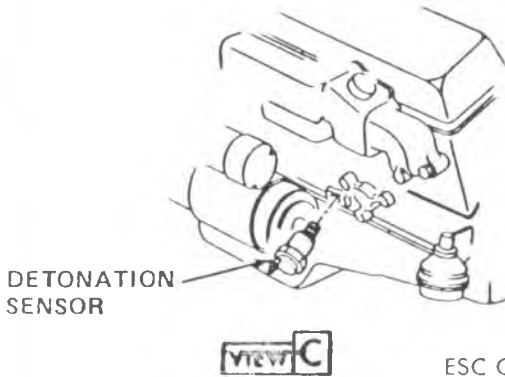

ESC Controller, Sensor and Wiring

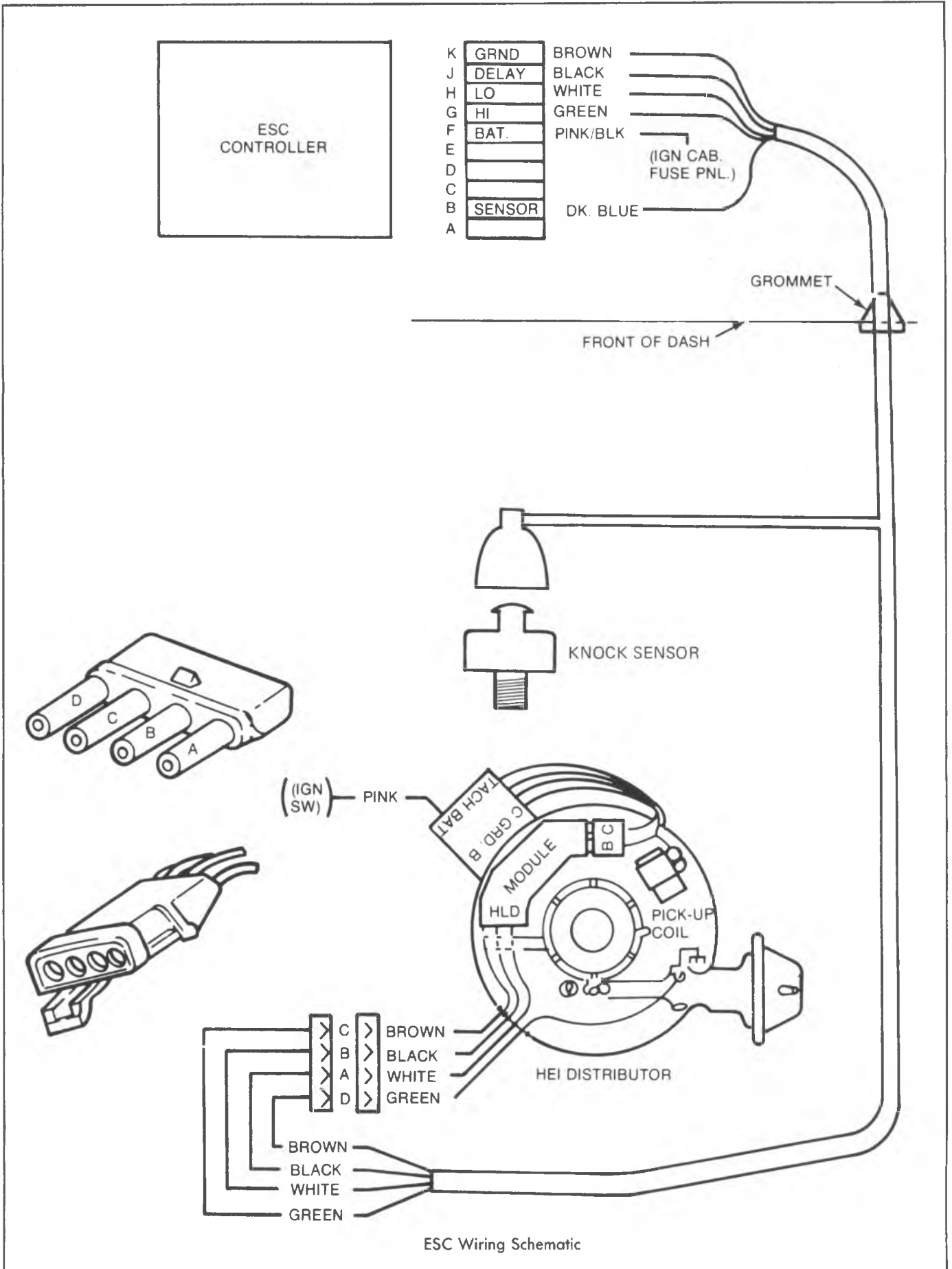



## ON-VEHICLE SERVICE

### H.E.I. DISTRIBUTOR

#### Service Precautions

1. When making compression checks, disconnect the ignition switch feed wire at the distributor. When disconnecting this connector do not use a screwdriver or tool to release the locking tab as it may break.
2. No periodic lubrication is required. Engine oil lubricates the lower bushing and an oil-filled reservoir provides lubrication for the upper bushing.
3. The tachometer (TACH) terminal is next to the ignition switch (BAT) connector on the distributor cap.

**NOTICE:** The tachometer terminal must NEVER be allowed to touch ground, as damage to the module and/or ignition coil can result.

**NOTICE:** Some service tachometers and electronic diagnostic equipment currently in use may NOT be compatible with the High Energy Ignition System. It is recommended that you consult your representative of such equipment as to the necessary updating of your equipment for compatibility with the HEI System.

4. There is no dwell adjustment as this is controlled by the module.
5. The centrifugal advance and vacuum advance are similar to the conventional ignition.
6. The material used to construct the spark plug cables is very pliable and soft. This cable will withstand more heat and carry a higher voltage. Due to the more pliable cable, scuffing and cutting become easier. It is therefore extremely important that the spark plug cables be routed correctly to prevent chaffing or cutting. See Spark Plug Section of On-Vehicle Service. Also when removing a spark plug wire from a spark plug, twist the boot on the spark plug and pull on the boot to remove the wire.

### Remove and Replace

#### Distributor

1. Disconnect ignition switch battery feed wire and tachometer lead (if equipped) from distributor cap. Also release the coil connectors from the cap. (DO NOT use a screwdriver or tool to release the locking tabs.)
2. Remove distributor cap by turning four latches counterclockwise. Move cap out of the way.

If necessary to remove secondary wires from cap, release wiring harness latches and remove wiring harness retainer. The spark plug wire numbers are indicated on the retainer.

3. Remove vacuum hose from vacuum advance unit.
4. Remove distributor clamp screw and hold-down clamp.
5. Note position of rotor, then pull distributor up until rotor just stops turning counterclockwise and again note position of rotor.

To insure correct timing of the distributor, the distributor must be INSTALLED with the rotor correctly positioned as noted in Step 5.

If the engine was accidentally cranked after the distributor was removed, the following procedure can be used for installing:

- a. Remove No. 1 spark plug.
- b. Place finger over No. 1 spark plug hole and crank engine slowly until compression is felt.
- c. Align timing mark on pulley to "O" on engine timing indicator.
- d. Turn rotor to point between No. 1 and No. 8 spark plug towers on distributor cap.
- e. Install distributor and connect ignition feed wire.
- f. Install distributor cap and spark plug wires.
- g. Check engine timing (see Set Ignition Timing below).

#### Vacuum Advance Unit

#### REMOVAL

1. Remove distributor cap and rotor.
2. Remove module.
3. Remove two vacuum advance attaching screws.
4. Turn the pick-up coil clockwise and push the rod end of the vacuum advance down so that it will disengage and clear the pick-up coil plate.

#### INSTALLATION

To install, reverse removal procedure.

#### Rotor

1. Remove distributor cap.
2. The rotor is retained by two screws and is provided with a slot which fits over a square lug on the advance weight base, so that the rotor can be installed in only one position.

#### Integral Ignition Coil

#### Removal

1. Remove distributor cap.
2. Remove three coil cover attaching screws, and lift off cover.
3. Remove coil attaching screws and lift ignition coil and lead from cap.

#### Installation

To install, reverse removal procedure.

#### Capacitor

The capacitor is part of the coil wire harness assembly. Since the capacitor is used only for radio noise suppression, it will seldom need replacement.

#### Removal

1. Remove distributor cap and rotor.
2. Remove capacitor attaching screw, and unplug connector from module. It may help to loosen the module.

#### Installation

1. To install, reverse above procedure.
2. Install hold down screw making sure ground lead is under screw.

## Unit Repair

## DISTRIBUTOR DISASSEMBLY TEST AND REASSEMBLY (COIL IN CAP)

## "COIL IN CAP" DISTRIBUTOR

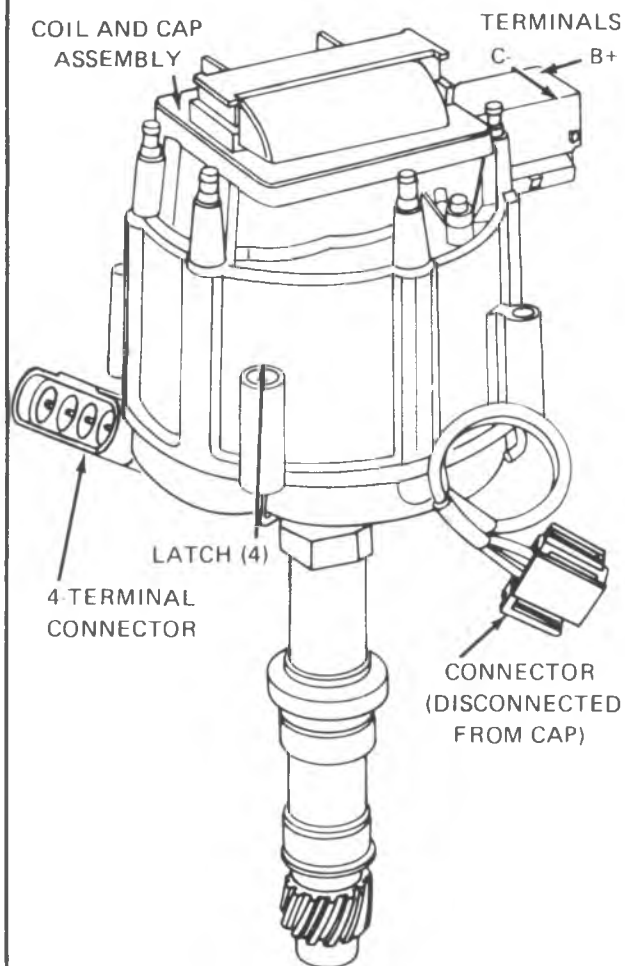

1. A 6-cyl. EST distributor with coil-in-cap is illustrated.
2. Detach wiring connector from cap, as shown.
3. Turn four latches and remove cap and coil assembly from lower housing.

210847

## TESTING IGNITION COIL

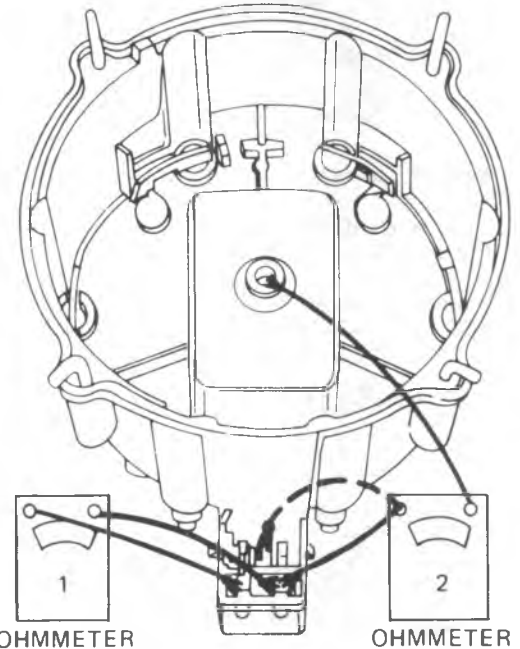

4. Connect ohmmeter. Test 1.
5. Reading should be zero, or nearly zero. If not, replace coil. Step 8.
6. Connect ohmmeter both ways. Test 2. Use high scale. Replace coil only if both readings are infinite. Step 8.
7. If coil is good, go to Step 13.

### IGNITION COIL ATTACHING SCREWS

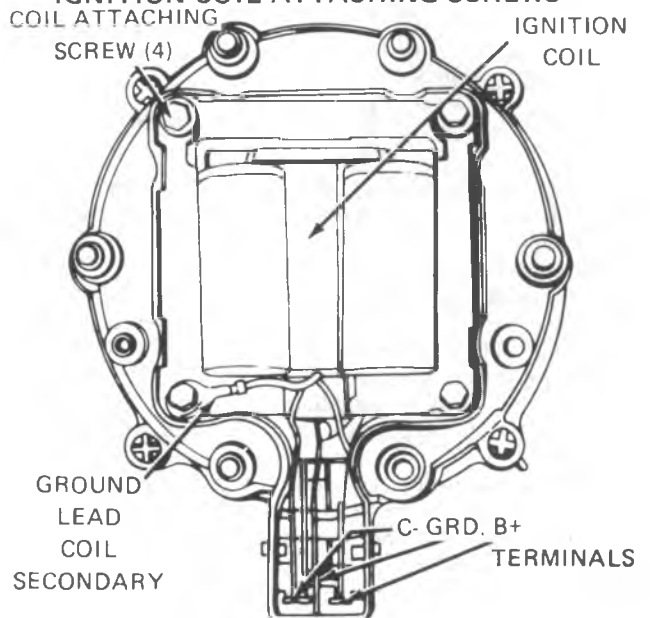

8. Remove coil-cover attaching screws and lift off cover.

Fig. 6D-61--Distributor Unit Repair

**IGNITION COIL REMOVED FROM CAP**

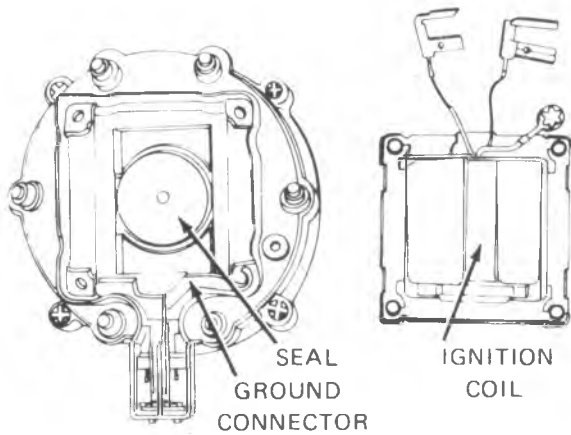

9. Remove ignition coil attaching screws and lift coil with leads from cap.
10. Remove ignition coil arc seal.
11. Clean with soft cloth and inspect cap for defects. Replace, if needed.
12. Assemble new coil and cover to cap.

**DRIVING PIN FROM SHAFT**

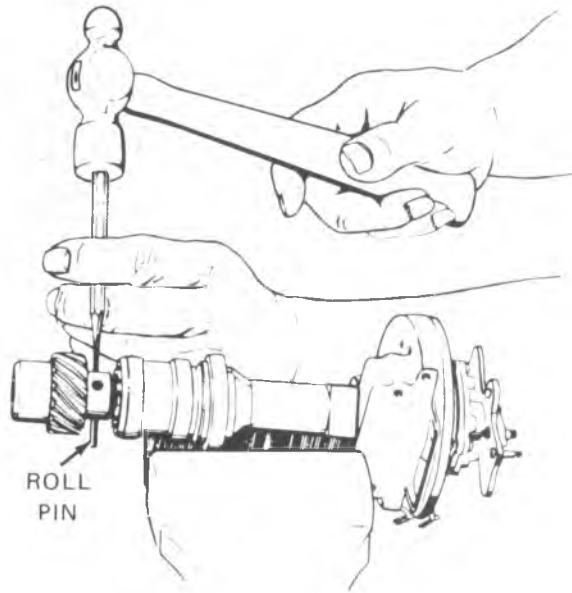

18. Mark distributor shaft and gear so they can be reassembled in same position.
19. Drive out roll pin.

**TESTING PICKUP COIL**

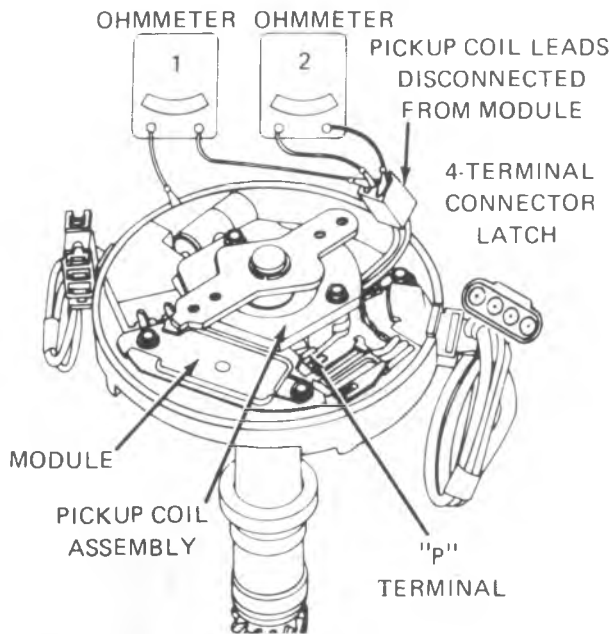

13. On all distributors, including distributors with Hall Effect Switch identified in Step 27, remove rotor and pickup coil leads from module.
14. Connect ohmmeter Test 1 and then Test 2.
15. If vacuum unit is used, connect vacuum source to vacuum unit. Replace unit if inoperative. Observe ohmmeter throughout vacuum range; flex leads by hand without vacuum to check for intermittent opens.
16. Test 1 — should read infinite at all times.  
Test 2 — should read steady at one value within 500-1500 ohm range.
- NOTE: Ohmmeter may deflect if operating vacuum unit causes teeth to align. This is not a defect.
17. If pickup coil is defective, go to Step 18. If okay, go to Step 23.

**SHAFT ASSEMBLY REMOVED**

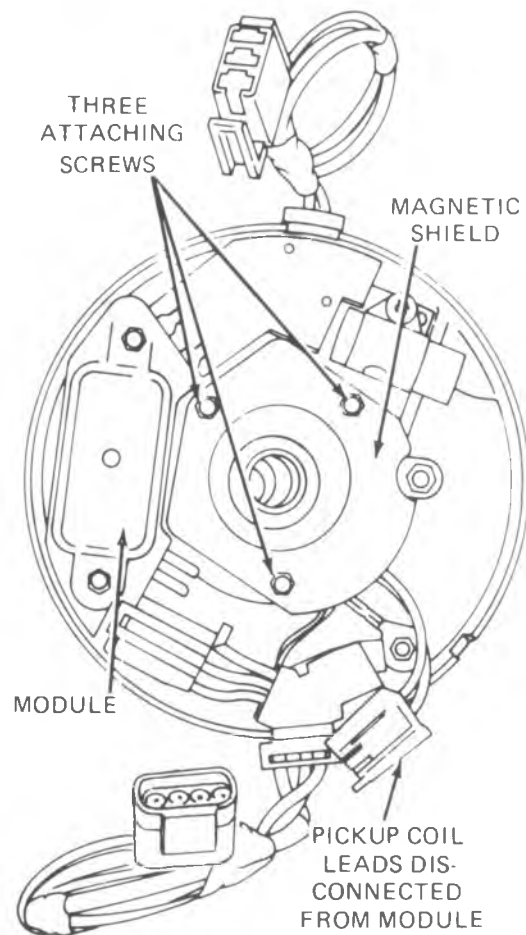

20. Remove gear and pull shaft assembly from distributor.

210848

Fig. 6D-62--Distributor Unit Repair

**ALUMINUM NON-MAGNETIC SHIELD REMOVED**

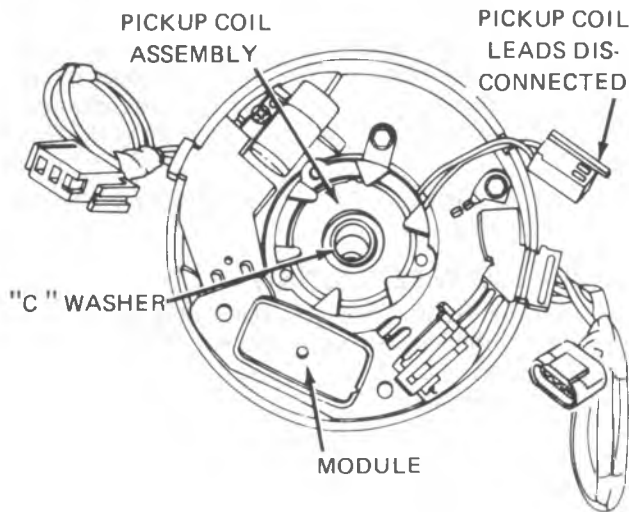

21. Remove three attaching screws and remove magnetic shield.

**MODULE REMOVED**

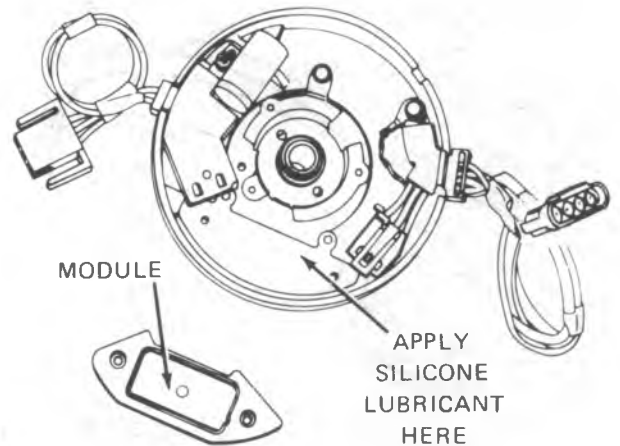

23. Remove two module attaching screws, and capacitor attaching screw. Lift module, capacitor and harness assembly from base.  
 24. Disconnect wiring harness from module.  
 25. Check module with an approved module tester.  
 26. Install module, wiring harness, and capacitor assembly. Use silicone lubricant on housing under module.

**PICKUP COIL REMOVED AND DISASSEMBLED**

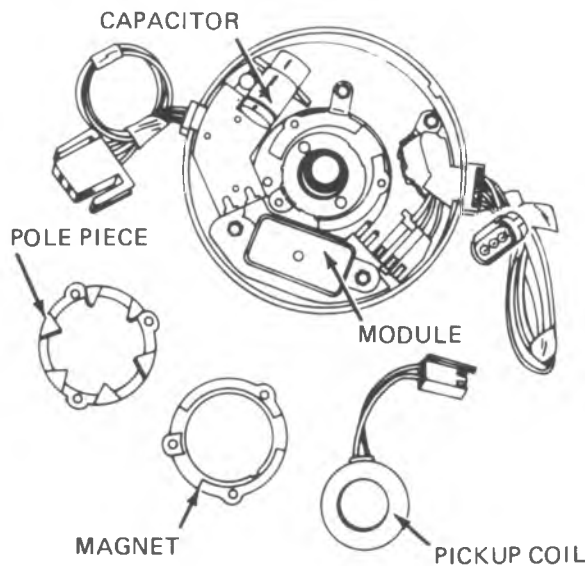

22. Remove retaining ring and remove pickup coil, magnet and pole piece.

**DISTRIBUTOR WITH HALL EFFECT SWITCH**

27. The procedures previously covered, Steps 1 - 26, apply also to distributors with Hall Effect Switches.

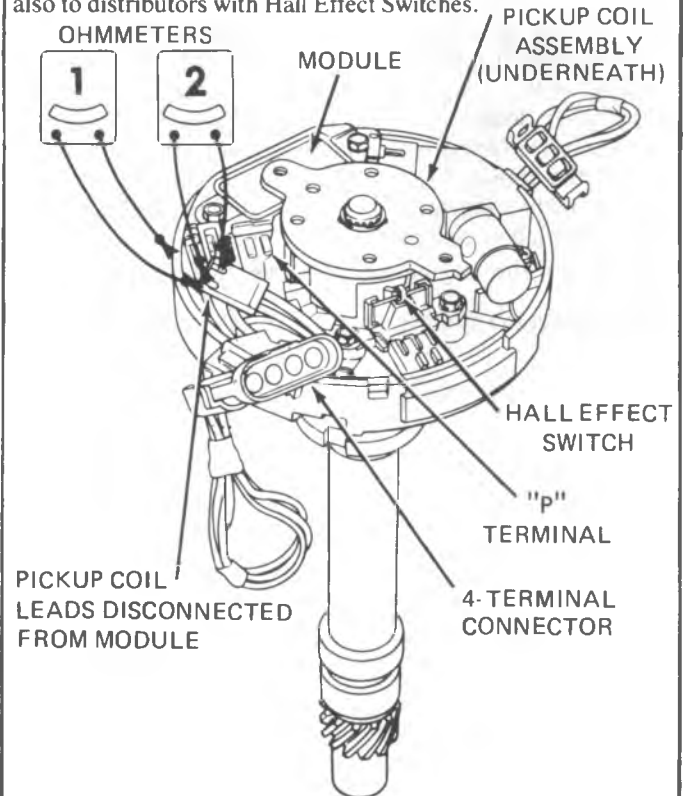

210849

Fig. 6D-63--Distributor Unit Repair

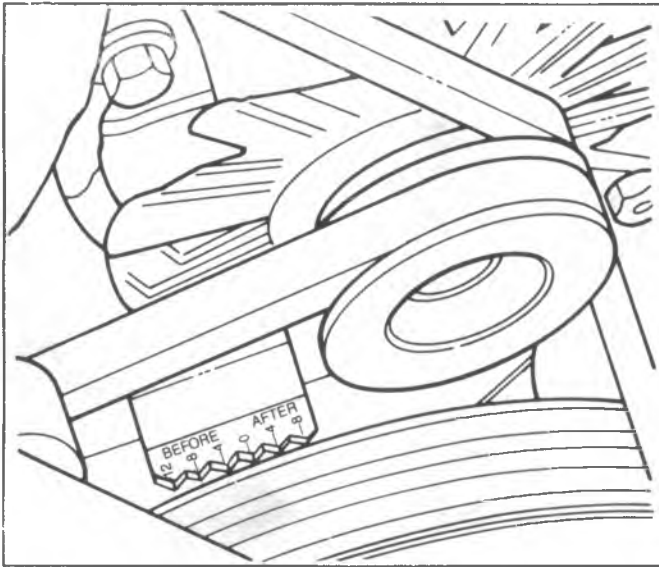

Fig. 6D-64--Timing Mark - Typical

### SET IGNITION TIMING

1. Refer to the Vehicle Emissions Control Information label located on the radiator support panel. Follow all instructions on the label.
2. With ignition off, connect the pick-up lead of timing light to the number one spark plug. Use a jumper lead between the wire and plug or an inductive type pick-up. DO NOT pierce the wire or attempt to insert a wire between the boot and the wire. Connect the timing light power leads according to manufacturer's instructions.
3. Start the engine, and aim the timing light at the timing mark (see Fig. 6D-64). The line on the balancer or pulley will line up at the timing mark. If a change is necessary, loosen the distributor hold-down clamp bolt at the base of the distributor. While observing the mark with the timing light, slightly rotate the distributor until the line indicates the correct timing. Tighten the hold-down bolt, and re-check the timing.
4. Turn off the engine and remove the timing light.

Reconnect the number one spark plug wire, if removed.

### SPARK PLUG WIRES

Use care when removing spark plug wire boots from spark plugs. Twist the boot 1/2 turn before removing, and pull on the boot only to remove the wire.

It is extremely important when replacing plug wires to route the wires correctly and through the proper retainers. Failure to route the wires properly can lead to radio ignition noise and crossfiring of the plugs, or shorting of the leads to ground.

Refer to Figures 6D-65 thru 6D-68 for proper spark plug wire routing.

### SPARK PLUG WIRE ROUTING

1983 C-K Series V8 engine spark plug wiring routing has been revised to minimize the possibility of crossfire between cylinders 5 and 7 on the left side and cylinders 4 and 8 on the right side.

It is important that the new routings be kept intact during service, and followed exactly when wires have been disconnected for any reason, or when replacement of the wires or wire becomes necessary. The correct wiring routing for the engines affected is shown in Figures 6D-66 and 67.

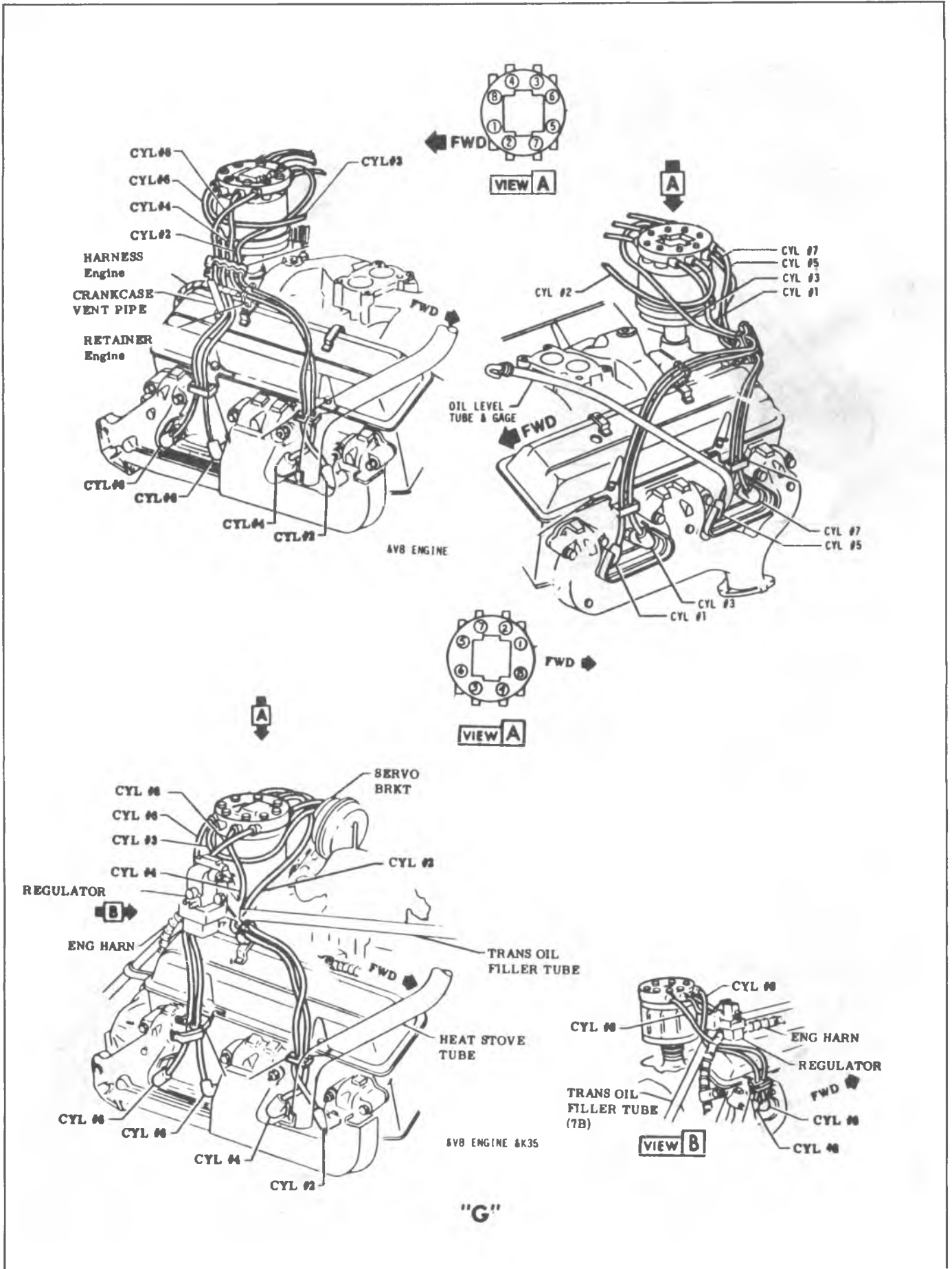

Fig. 6D-65--Spark Plug Wire Routing



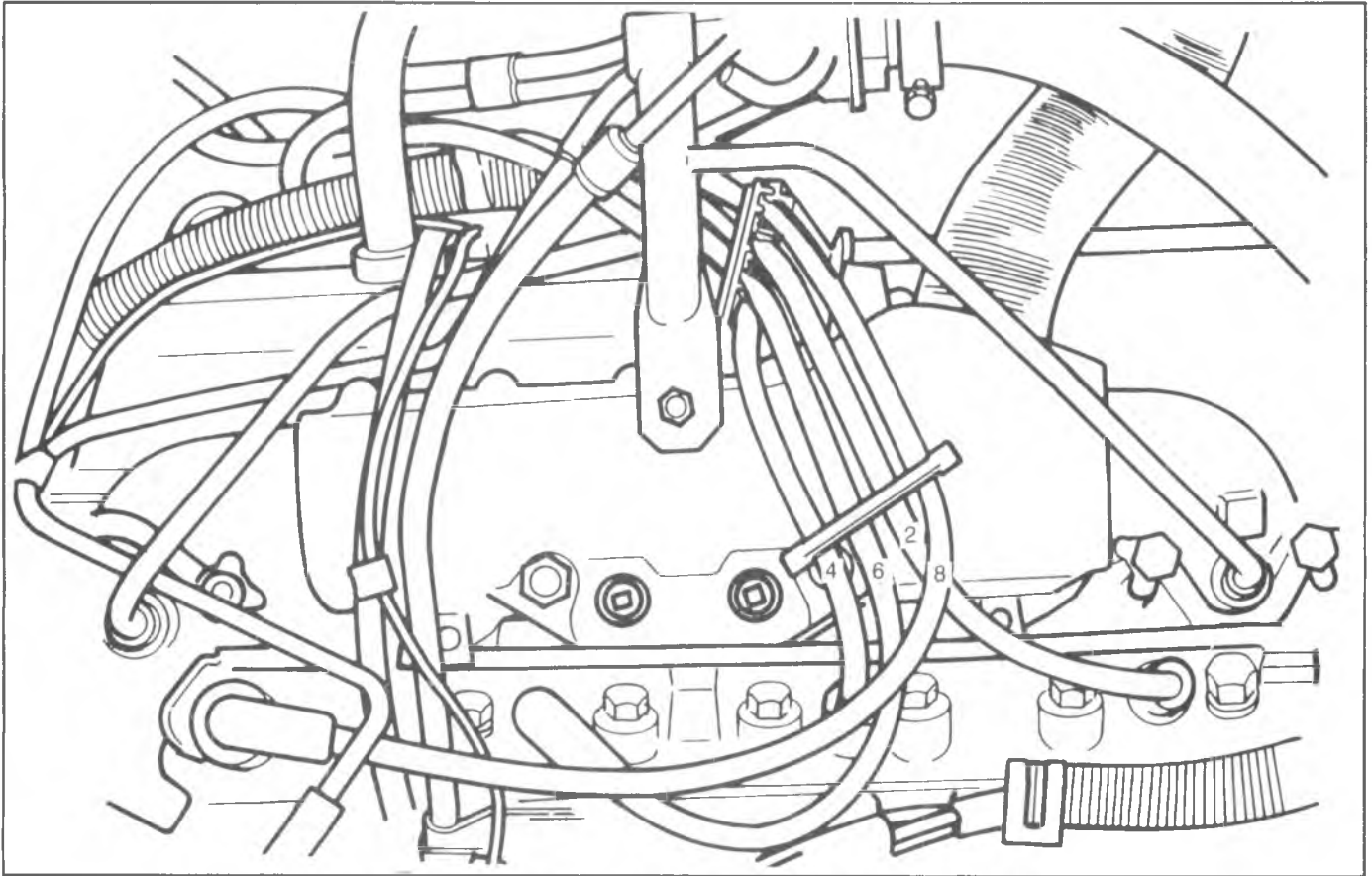

Fig. 6D-66--CK Series V8 Engines Spark Plug Wiring Routing-Right Side

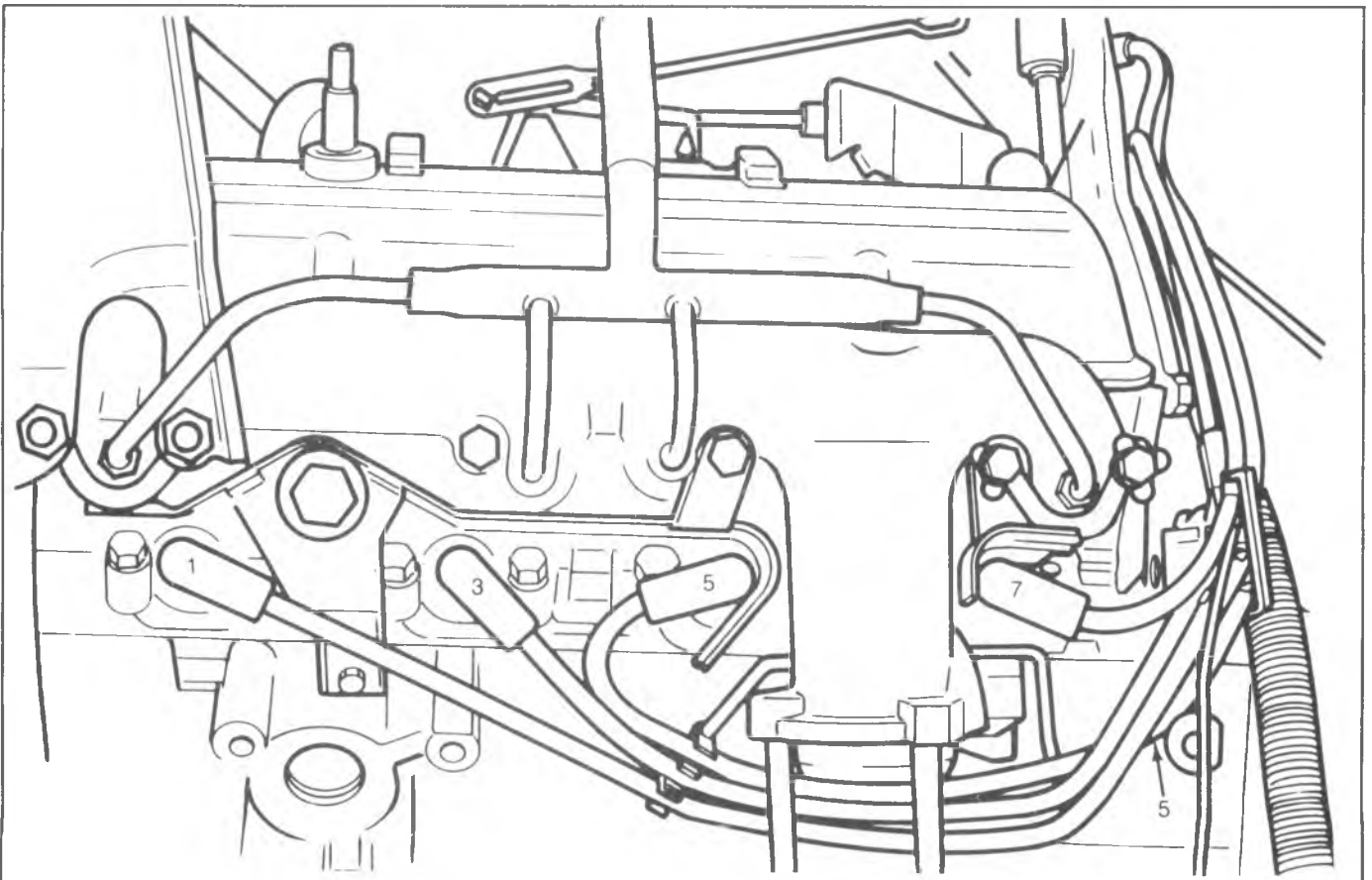

Fig. 6D-67--CK Series V8 Engines Spark Plug Wiring Routing-Left Side

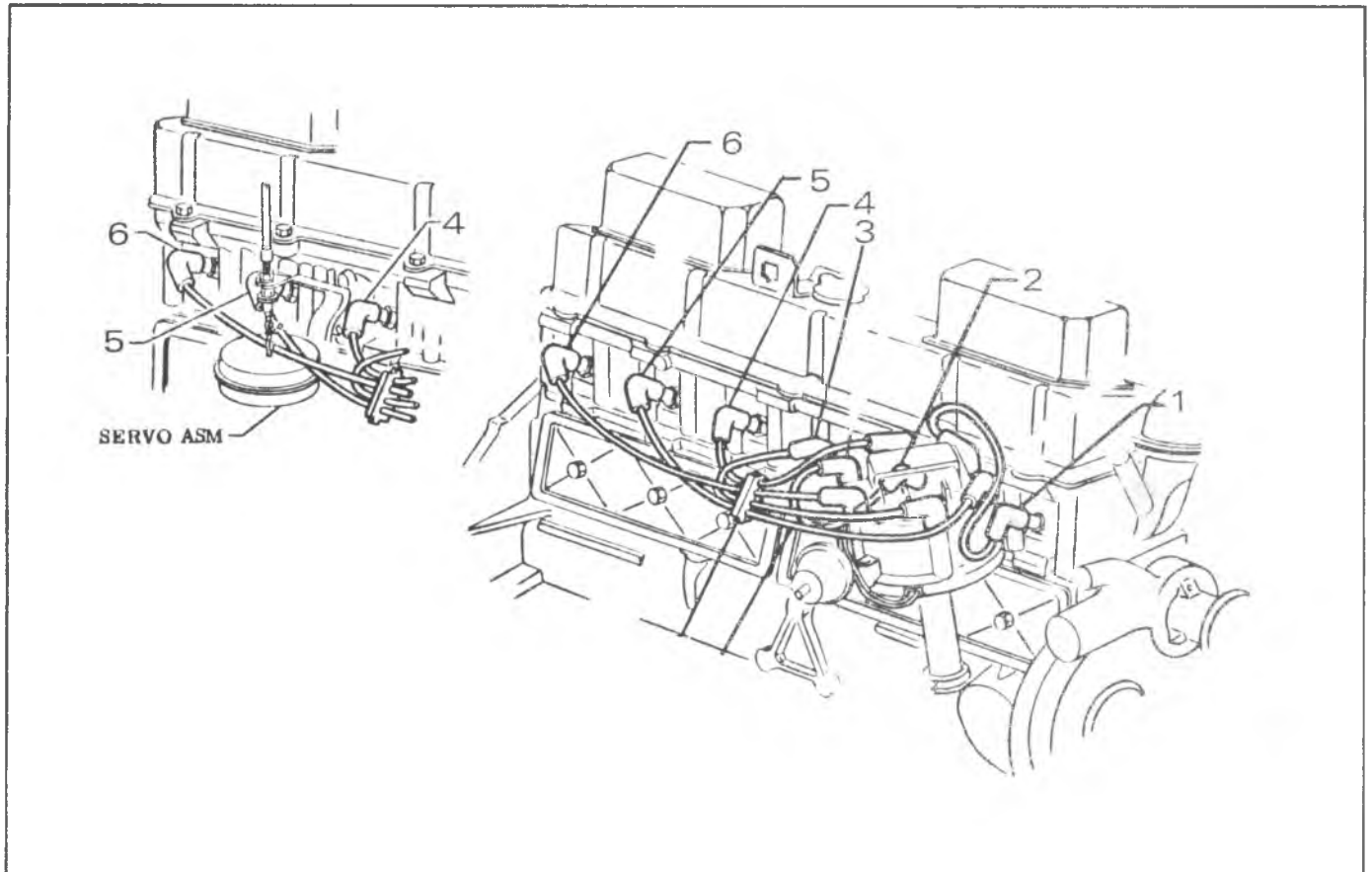

Fig. 6D-68--Spark Plug Wiring Routing-G Series

## IGNITION SWITCH

### GENERAL DESCRIPTION

The electrical switching portion of the assembly is separate from the key and lock cylinder. However, both are synchronized and work in conjunction with each other through the action of the actuator rod assembly. For a complete explanation of the key and lock cylinder, and the actuator rod assembly, refer to the Steering section of this manual.

The ignition switch is key operated through the actuator rod assembly to close the ignition primary circuit and to energize the starting motor solenoid for cranking. The ignition switch used on all vehicles have five positions: OFF, LOCK, ACCESSORY, RUN and START. OFF is the center position of the key-lock cylinder, and LOCK is the next position to the left. ACCESSORY is located one more detent to the left of LOCK. Turning the key to the right of the OFF position until spring pressure is felt will put the ignition switch in the RUN position, and when turned fully to the right against spring pressure, the switch will be in the START position.

All ignition switches have five terminals which are connected in different combinations for each of the three operating positions. A brass plate, inside the switch, has three contacts which connect these terminals. Figure 6D-31D shows the positions of the contacts in all positions as viewed from the key side of the switch. There is also a ground pin in the switch which contacts the "ground"

terminal when the ignition switch is in the START position. This pin contacts the IGN. terminal when in the OFF position.

#### Ignition Start and Run Circuit

The ignition switch is fed from the battery to the BAT. terminal of the switch. When the ignition switch is in the OFF position, no current flows through the switch. When the ignition switch is turned to the ACC. position, the BAT. terminal is connected to the ACC. terminal. This permits operation of accessories when the engine is not running.

When the ignition switch is turned to the START position, the BAT. terminal is connected to the SOL. and IGN. terminals. When the clutch or automatic transmission neutral start switches are closed, current flows to the starter solenoid. This energizes the solenoid windings. The solenoid has two sets of windings: a "pull-in" winding and a "hold-in" winding. Both windings are used to create the magnetic field to actuate the the solenoid plunger and move the starter pinion into engagement with the flywheel. As the solenoid plunger reaches the end of its travel, it closes a switch which connects battery voltage to the starter motor. With battery voltage applied to both terminals of the "pull-in" windings, the "pull-in" winding is no longer energized, so that only the "hold-in" winding keeps the starter solenoid engaged.

The instrument panel warning lights are fed from the ignition terminal of the ignition switch and have battery



voltage applied to them when the ignition switch is in the START and RUN position. These circuits are explained in the Chassis Electrical Section.

When the ignition switch is released from the START to the RUN position, the IGN. terminal is still connected to the BAT. terminal. With the ignition switch in the RUN position, the BAT. terminal is connected to the IGN.

terminal and the ACC. terminal. This permits operation of all accessories and the ignition system.

### **ENGINE WIRING HARNESSES**

Engine Wiring Harnesses are shown in Figures 6D-70 through 6D-75.

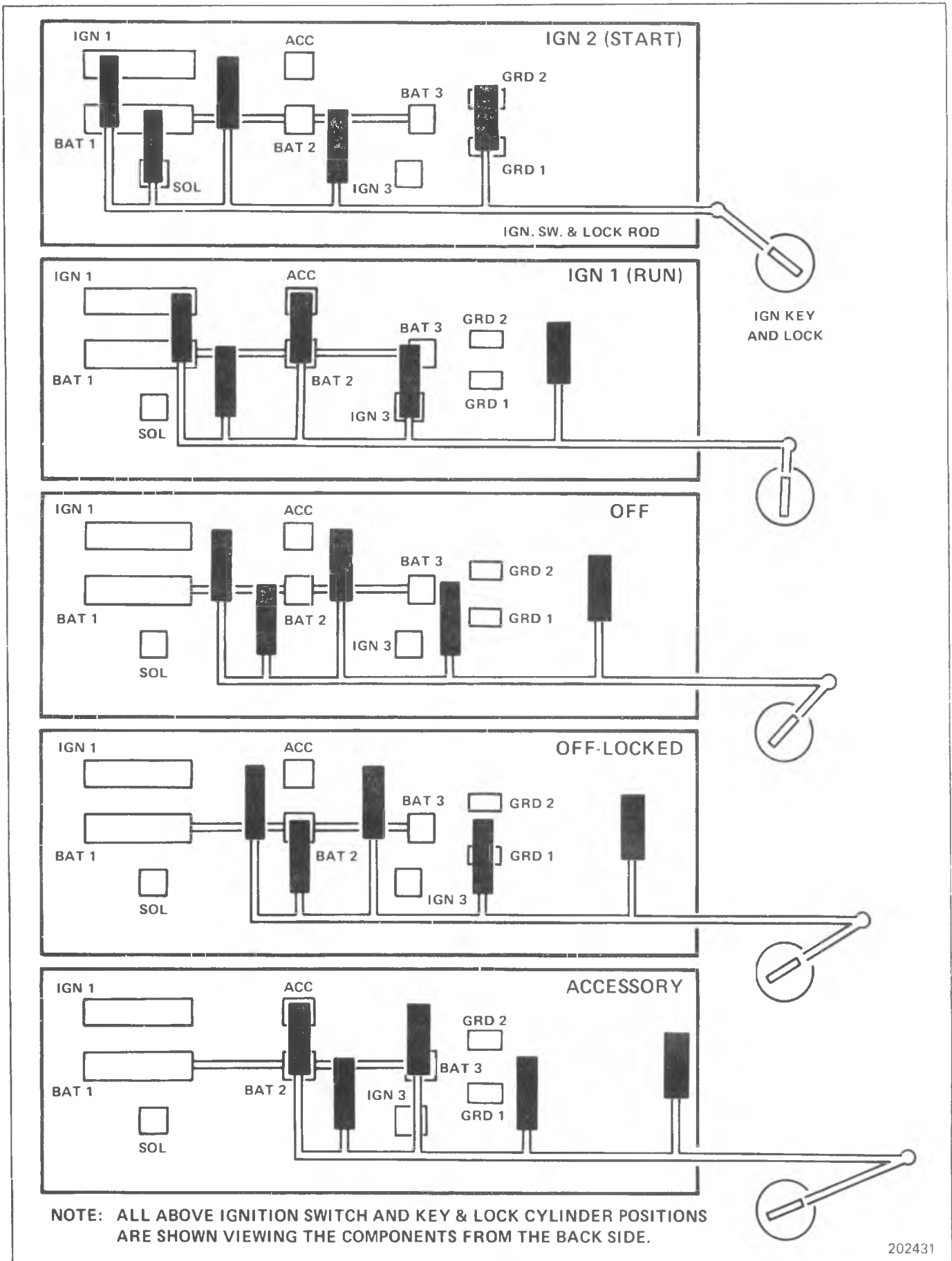

202431

Fig. 6D-69--Ignition Switch Circuit

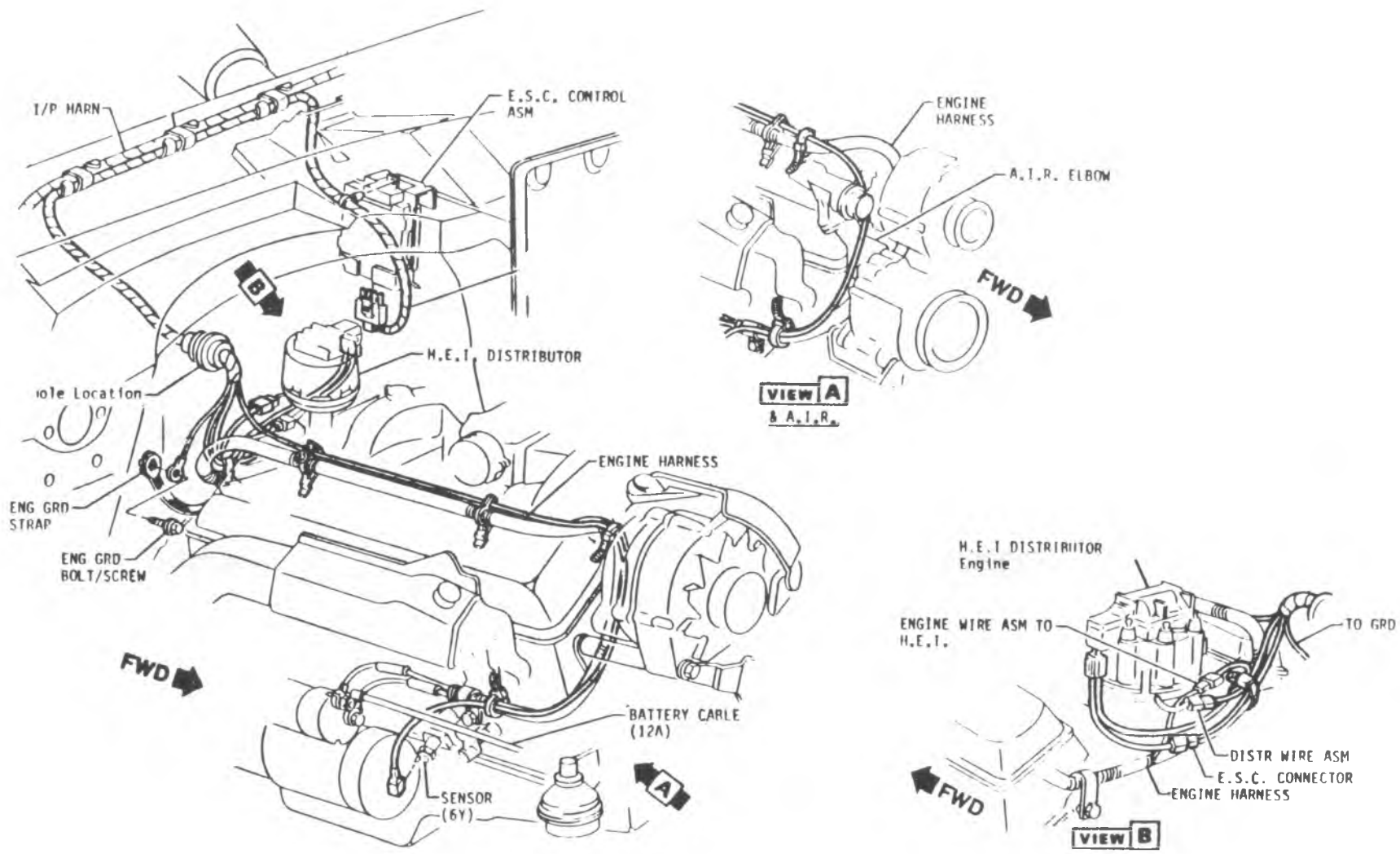

Fig. 6D-70--Engine Wiring LE9, LF3, LG9, LS9

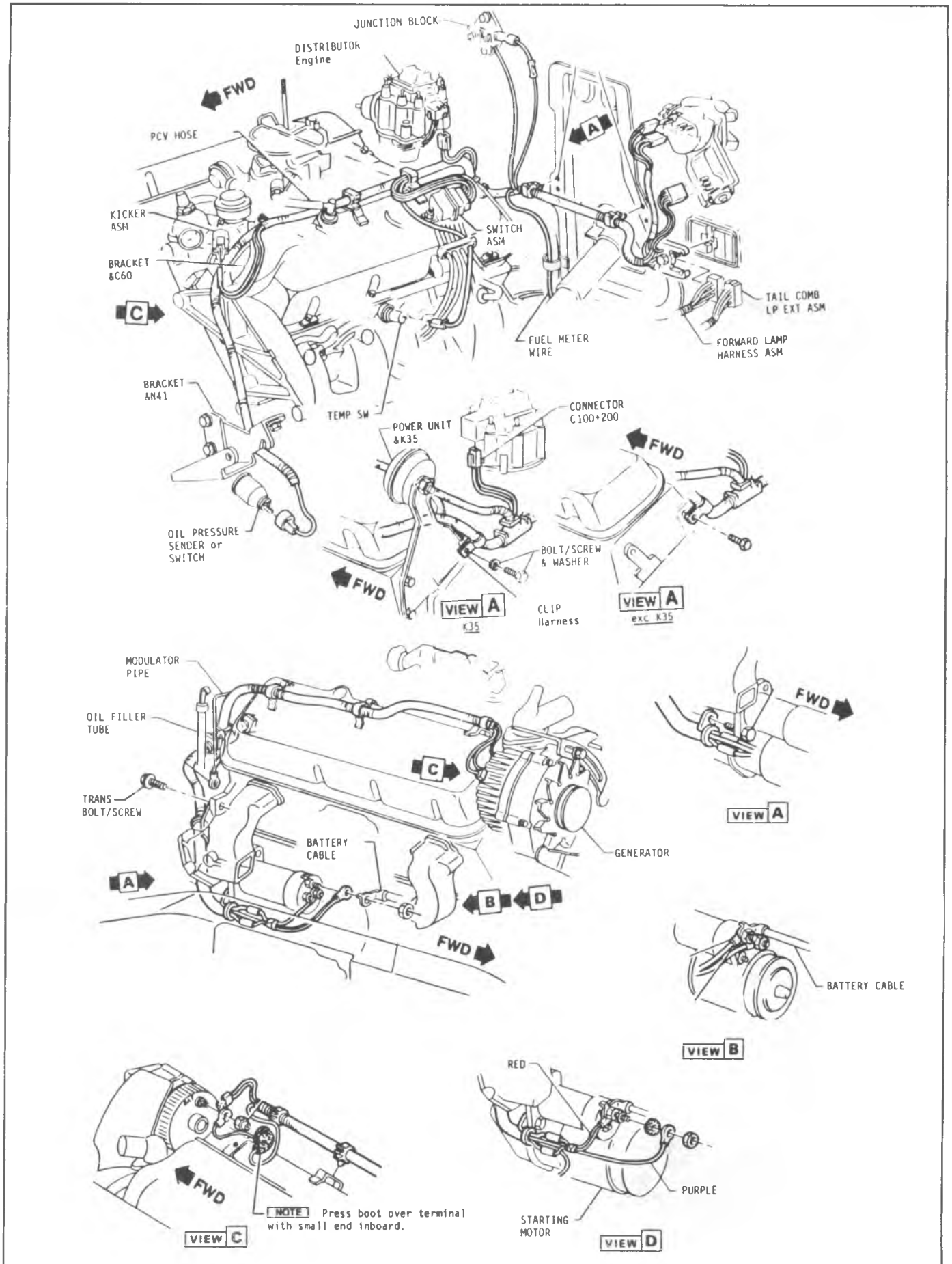

Fig. 6D-71--Engine Wiring CK-20, 30 - LE8

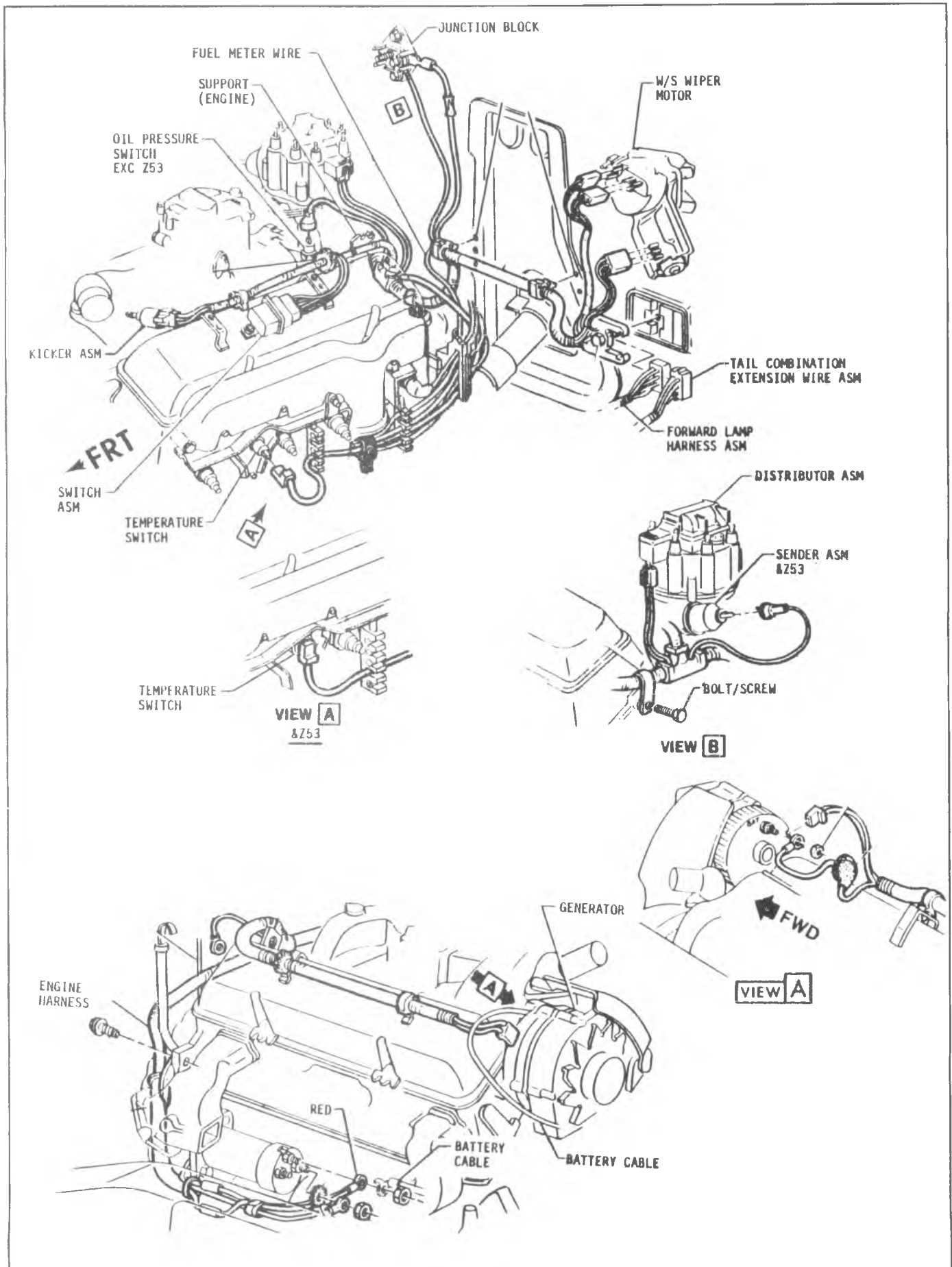

Fig. 6D-72--Engine Wiring CK-20, 30 - LT9

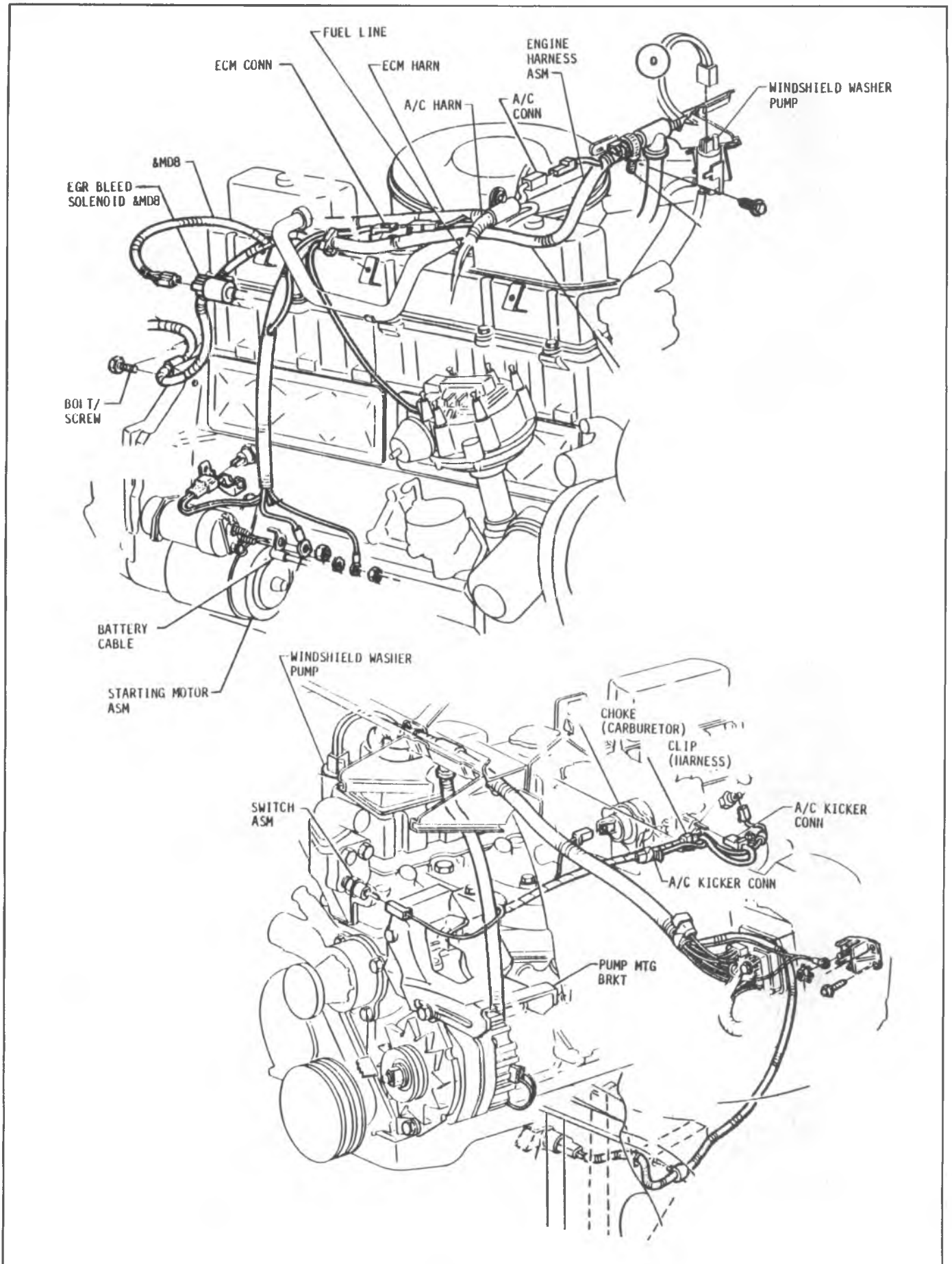

Fig. 6D-73--Engine Wiring G Series LE3

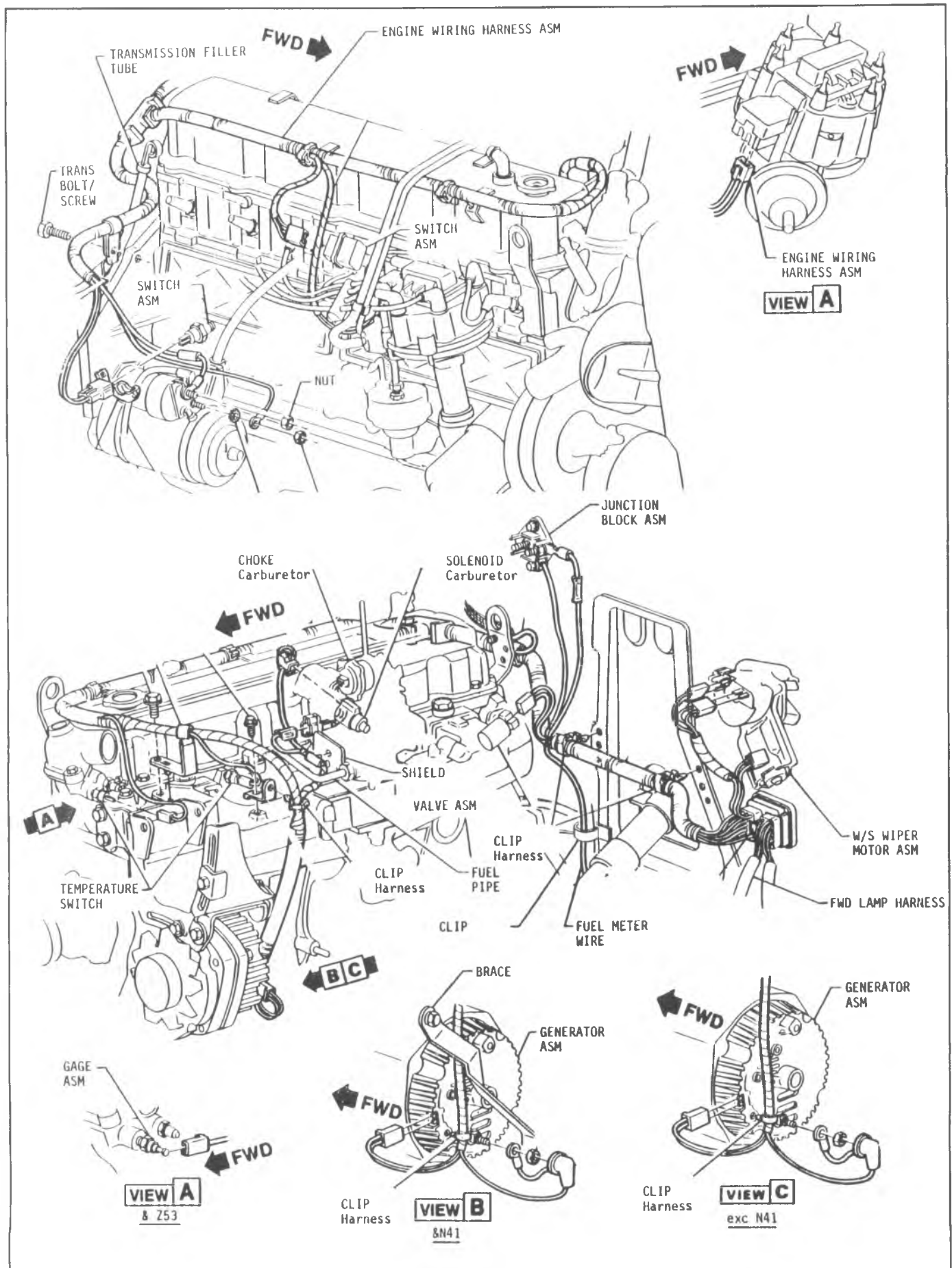

Fig. 6D-74--Engine Wiring CK Series- L25



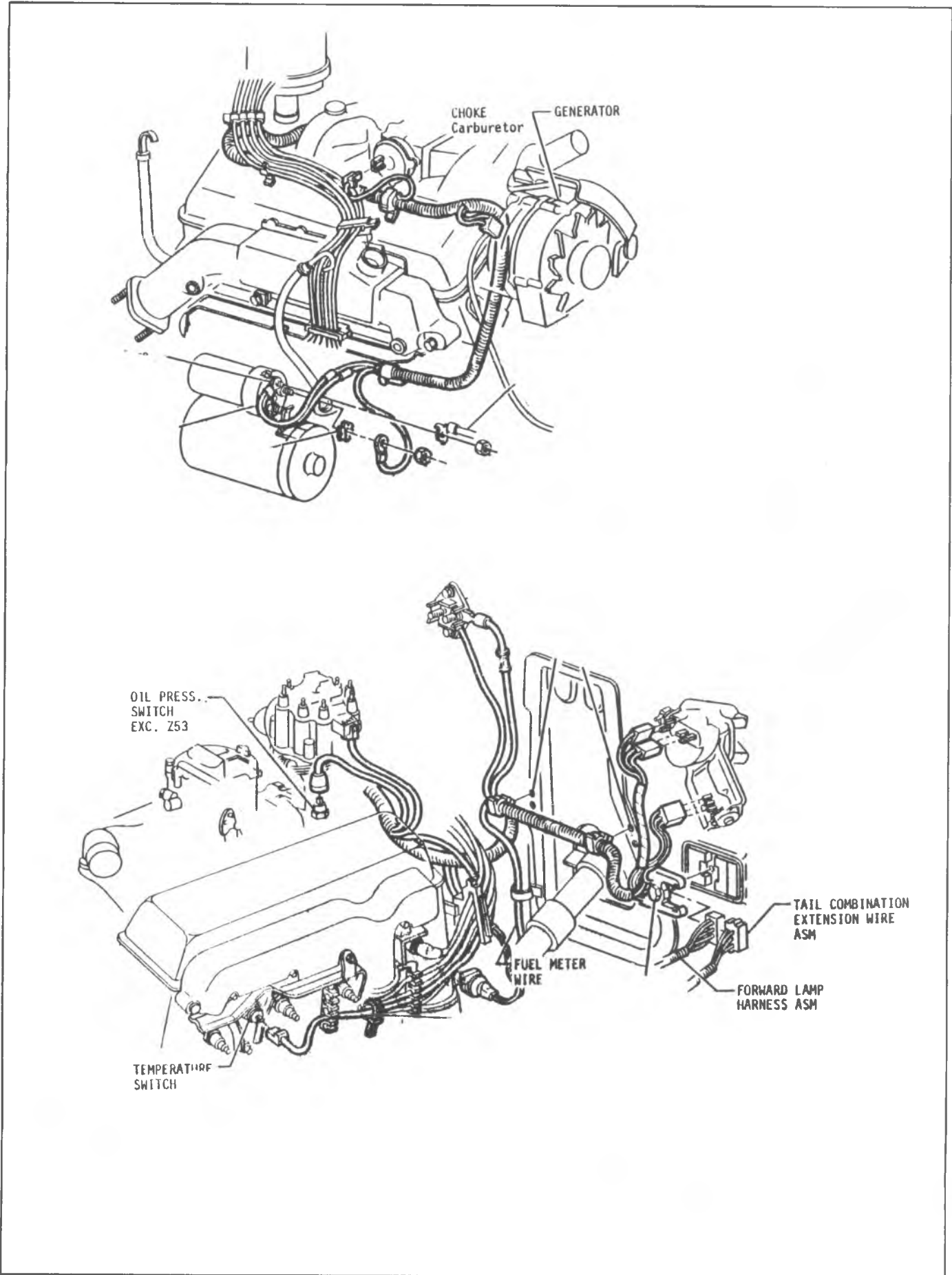

Fig. 6D-75--Engine Wiring CK Series - LE9



## CRANKING SYSTEM

|                          |       |                           |       |
|--------------------------|-------|---------------------------|-------|
| General Description..... | 6D-74 | Solenoid .....            | 6D-82 |
| Cranking Circuit .....   | 6D-74 | Overhaul .....            | 6D-82 |
| Starter Motor .....      | 6D-74 | Disassembly .....         | 6D-82 |
| Diagnosis.....           | 6D-78 | Component Inspection..... | 6D-83 |
| On-Vehicle Service.....  | 6D-81 | Reassembly.....           | 6D-86 |
| Remove and Replace.....  | 6D-81 | Specifications .....      | 6D-88 |
| Starter.....             | 6D-81 |                           |       |

## GENERAL DESCRIPTION

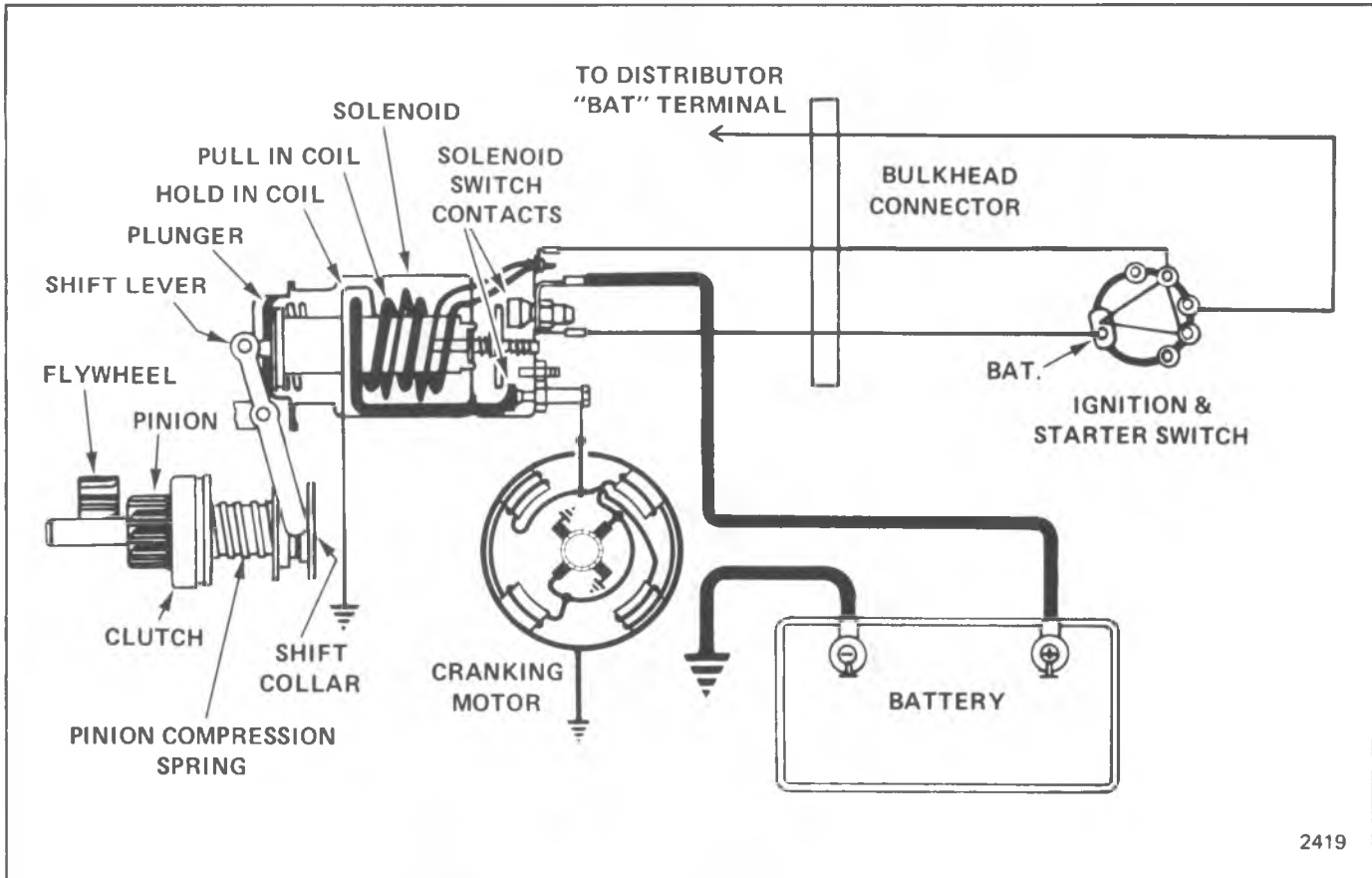

Fig. 6D-76--Cranking Circuit - All

### CRANKING CIRCUIT

The cranking circuit consists of the battery, starting motor, ignition switch, and related electrical wiring. These components are connected electrically as shown in Figure 6D-76. Only the starting motor will be covered in this portion.

### STARTING MOTOR

Three types of starter motors are used. The first referred to as the 5MT Phase III is shown in Figs. 6D-77 and 6D-78. The second, referred to as the 10MT series, is shown in Fig. 6D-79. The third type, referred to as the 27MT series used on diesel equipped engines, is shown in Fig. 6D-80. The main difference is that the 27MT has a

center bearing. Differences in service procedures will be pointed out as they occur.

Enclosed shift lever cranking motors have the shift lever mechanism and the solenoid plunger enclosed in the drive housing protecting them from exposure to dirt, icing conditions and splash.

In the basic circuit shown in Figure 6D-1E, the solenoid windings are energized when the switch is closed. The resulting plunger and shift lever movement causes the pinion to engage the engine flywheel ring gear and the solenoid main contacts to close, and cranking takes place. When the engine starts, pinion overrun protects the armature from excessive speed until the switch is opened, at which time the return spring causes the pinion to disengage. To prevent excessive overrun, the switch should be opened immediately when the engine starts.

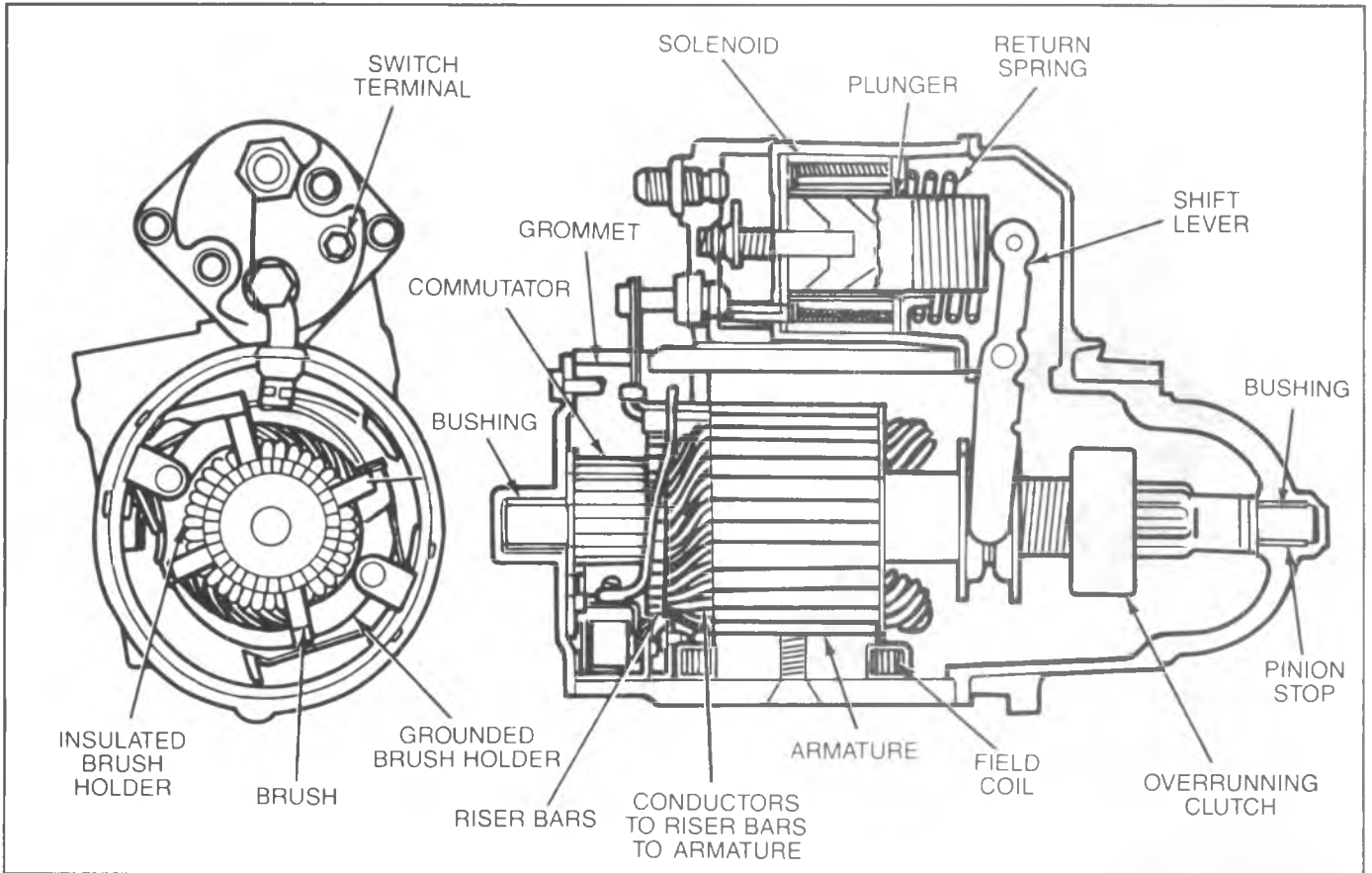
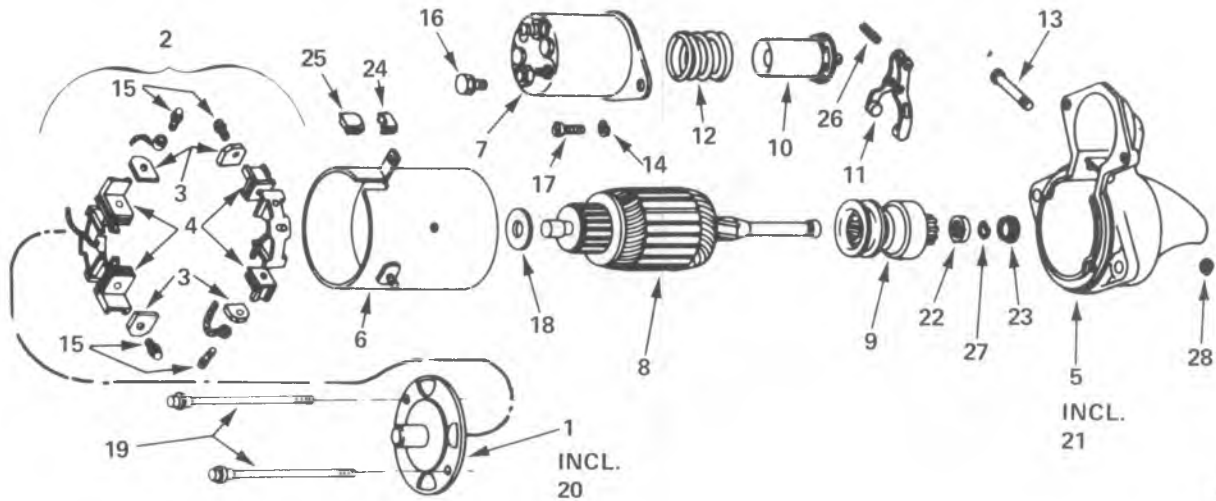

Fig. 6D-77--Cross Section of 5MT Starting Motor



6222

- 1. FRAME-COMMUTATOR END
- 2. BRUSH AND HOLDER PKG.
- 3. BRUSH
- 4. BRUSH HOLDER
- 5. HOUSING-DRIVE END
- 6. FRAME AND FIELD ASM.
- 7. SOLENOID SWITCH
- 8. ARMATURE
- 9. DRIVE ASM.

- 10. PLUNGER
- 11. SHIFT LEVER
- 12. PLUNGER RETURN SPRINGER
- 13. SHIFT LEVER SHAFT
- 14. LOCK WASHER
- 15. SCREW-BRUSH ATTACHING
- 16. SCREW-FIELD LEAD TO SWITCH
- 17. SCREW-SWITCH ATTACHING
- 18. LEATHER WASHER-BRAKE

- 19. THRU BOLT
- 20. BUSHING-COMMUTATOR END
- 21. BUSHING-DRIVE END
- 22. PINION STOP COLLAR
- 23. THRUST COLLAR
- 24. GROMMET
- 25. GROMMET
- 26. PLUNGER PIN
- 27. PINION STOP RETAINER RING
- 28. LEVER SHAFT RETAINING RING

Fig. 6D-78--Exploded View, 5MT Motor

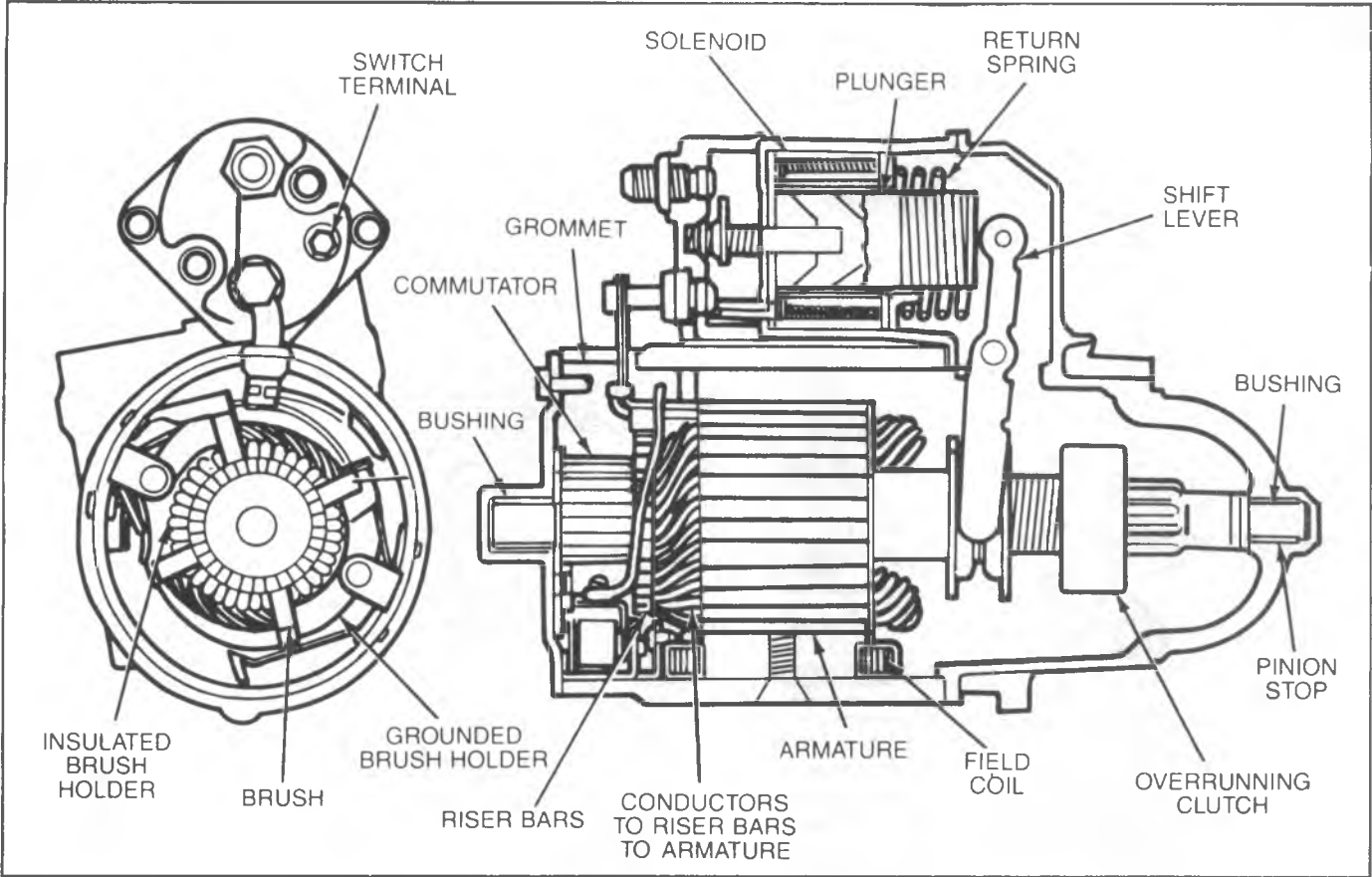

Fig. 6D-79--Cross Section of 10MT Starting Motor

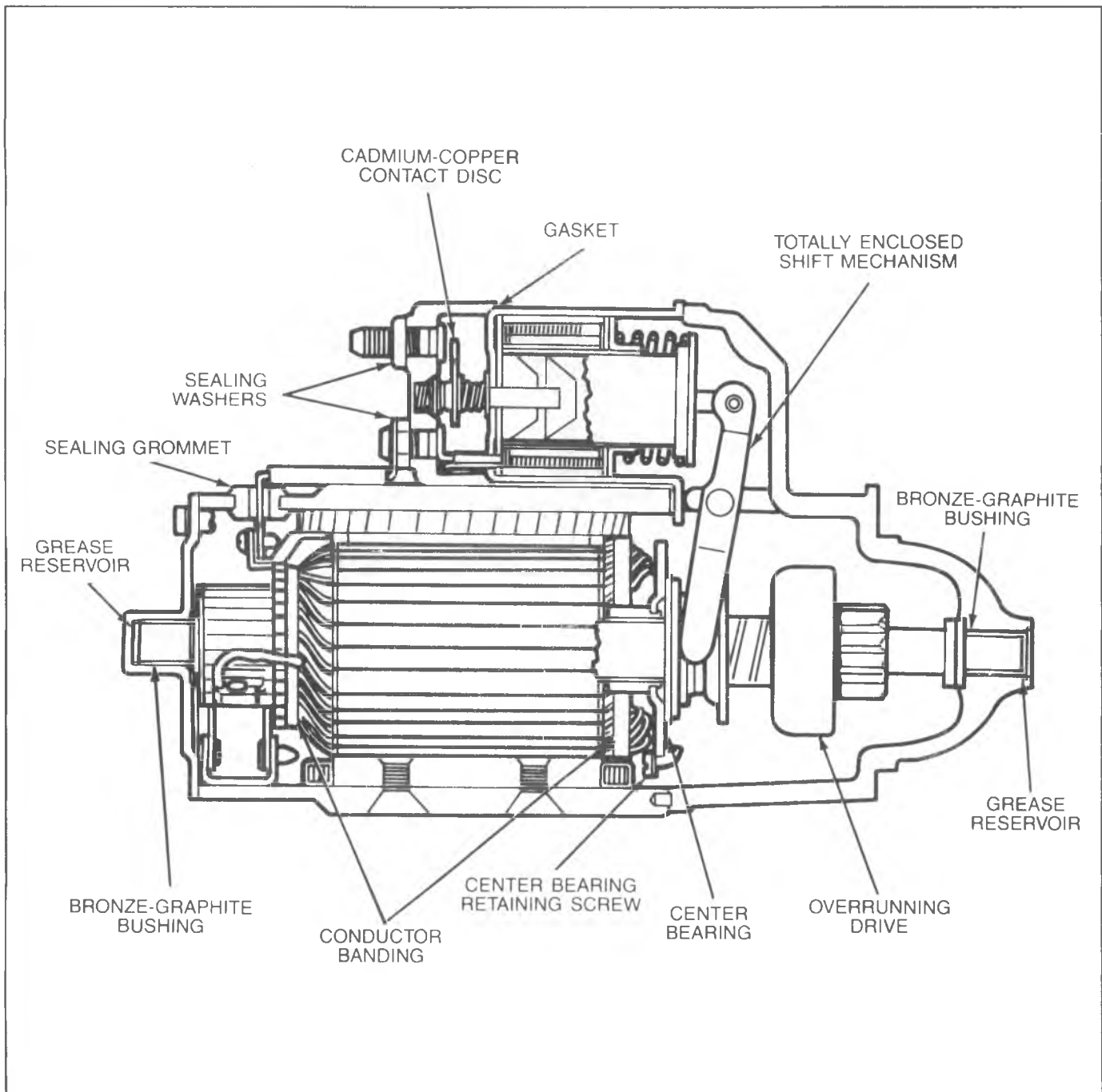

Fig. 6D-80--Cross Section of 27MT Starting Motor

## DIAGNOSIS

Before removing any unit in a cranking circuit for repair, the following checks should be made:

### Battery:

To determine the condition of the battery, follow the testing procedure outlined in the Battery Section.

### Wiring:

Inspect the wiring for damage. Inspect all connections to the cranking motor, solenoid, ignition switch, and battery, including all ground connections. Clean and tighten all connections as required.

### Solenoid and Ignition Switch:

Inspect all switches to determine their condition.

### Starter Motor Noise:

To correct starter motor noise during starting, use the following procedure:

1. Refer to Fig. 6D-81 to determine the problem.
2. If the complaint is similar to problem categories 1 or 2 above, correction can be achieved by proper "shimming".
  - a. Remove lower flywheel housing cover and examine for visual problems - bent flywheel, unusual wear, etc.

| PROBLEM   | CAUSE   |
|---|---|
| 1. HIGH PITCHED WHINE DURING CRANKING (BEFORE ENGINE FIRES) BUT ENGINE CRANKS AND FIRES OKAY.   | DISTANCE TOO GREAT BETWEEN STARTER PINION AND FLYWHEEL.   |
| 2. HIGH PITCHED "WHINE" AFTER ENGINE FIRES, AS KEY IS BEING RELEASED. ENGINE CRANKS AND FIRES OKAY. THIS INTERMITTENT COMPLAINT IS OFTEN DIAGNOSED AS "STARTER HANG-IN" OR "SOLENOID WEAK." | DISTANCE TOO SMALL BETWEEN STARTER PINION AND FLYWHEEL. FLYWHEEL RUNOUT CONTRIBUTES TO THE INTERMITTENT NATURE. |
| 3. A LOUD "WHOOOP" AFTER THE ENGINE FIRES BUT WHILE THE STARTER IS STILL HELD ENGAGED. SOUNDS LIKE A SIREN IF THE ENGINE IS REVVED WHILE STARTER IS ENGAGED.                                | MOST PROBABLE CAUSE IS A DEFECTIVE CLUTCH. A NEW CLUTCH WILL OFTEN CORRECT THIS PROBLEM.                        |
| 4. A "RUMBLE", "GROWL" OR (IN SEVERE CASES) A "KNOCK" AS THE STARTER IS COASTING DOWN TO A STOP AFTER STARTING THE ENGINE.  | MOST PROBABLE CAUSE IS A BENT OR UNBALANCED STARTER ARMATURE. A NEW ARMATURE WILL OFTEN CORRECT THIS PROBLEM.   |

5488

Fig. 6D-81--Starter Motor Noise Diagnosis

- b. Start engine and carefully touch outside diameter of rotating flywheel ring gear with chalk or crayon to show high point of tooth runout after engine is turned off. Turn engine off and rotate flywheel so that the marked teeth are in the area of the starter pinion gear.
- c. Disconnect negative battery cable to prevent inadvertent cranking of engine.
- e. If the clearance is grossly over .5mm (.020") (in the vicinity of 1.5mm (.060") or more), shimming the starter towards the flywheel is required. (This is generally the problem causing broken flywheel teeth or starter housings.)

Shimming the starter towards the flywheel can be accomplished by shimming only the outboard starter mounting pad. A shim of .4mm (.015") thickness at this location will decrease the clearance by approximately .3mm (.010").

If normal starter shims are not available, substitute shims can be improvised from plain washers or other suitable material.

**Motor:**

If the battery, wiring and switches are in satisfactory condition, and the engine is known to be functioning properly, remove the motor and follow the test procedures outlined below.

Regardless of the construction, never operate the cranking motor more than 30 seconds at a time without pausing to allow it to cool for at least two minutes. Overheating, caused by excessive cranking, will seriously damage the cranking motor.

A general diagnosis is covered in Figure 6D-1 and 6D-2. Once a problem has been traced to the starter, proceed to the test procedure below.

**Test Procedure**

With the cranking motor removed from the engine, the pinion should be checked for freedom of operation by turning it on the screw shaft. The armature should be checked for freedom of rotation by prying the pinion with a screwdriver. Tight bearings, a bent armature shaft, or a loose pole shoe screw will cause the armature to not turn freely. If the armature does not turn freely the motor should be disassembled immediately. However, if the armature does rotate freely, the motor should be given a no-load test before disassembly.

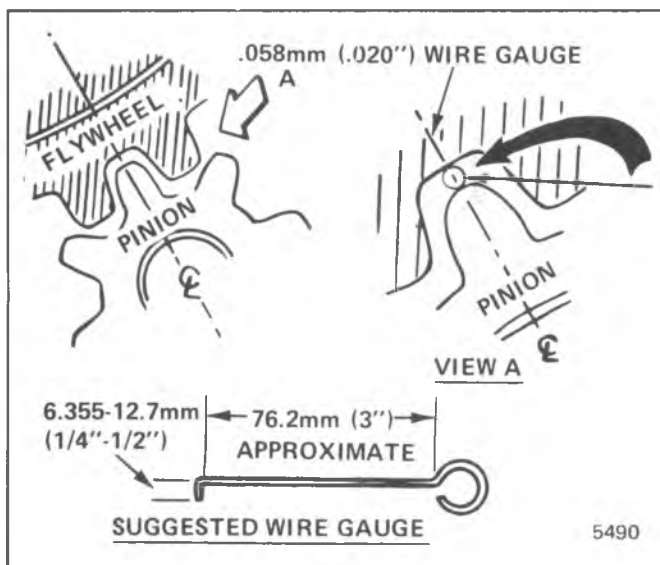

Fig. 6D-82--Flywheel to Pinion Clearance

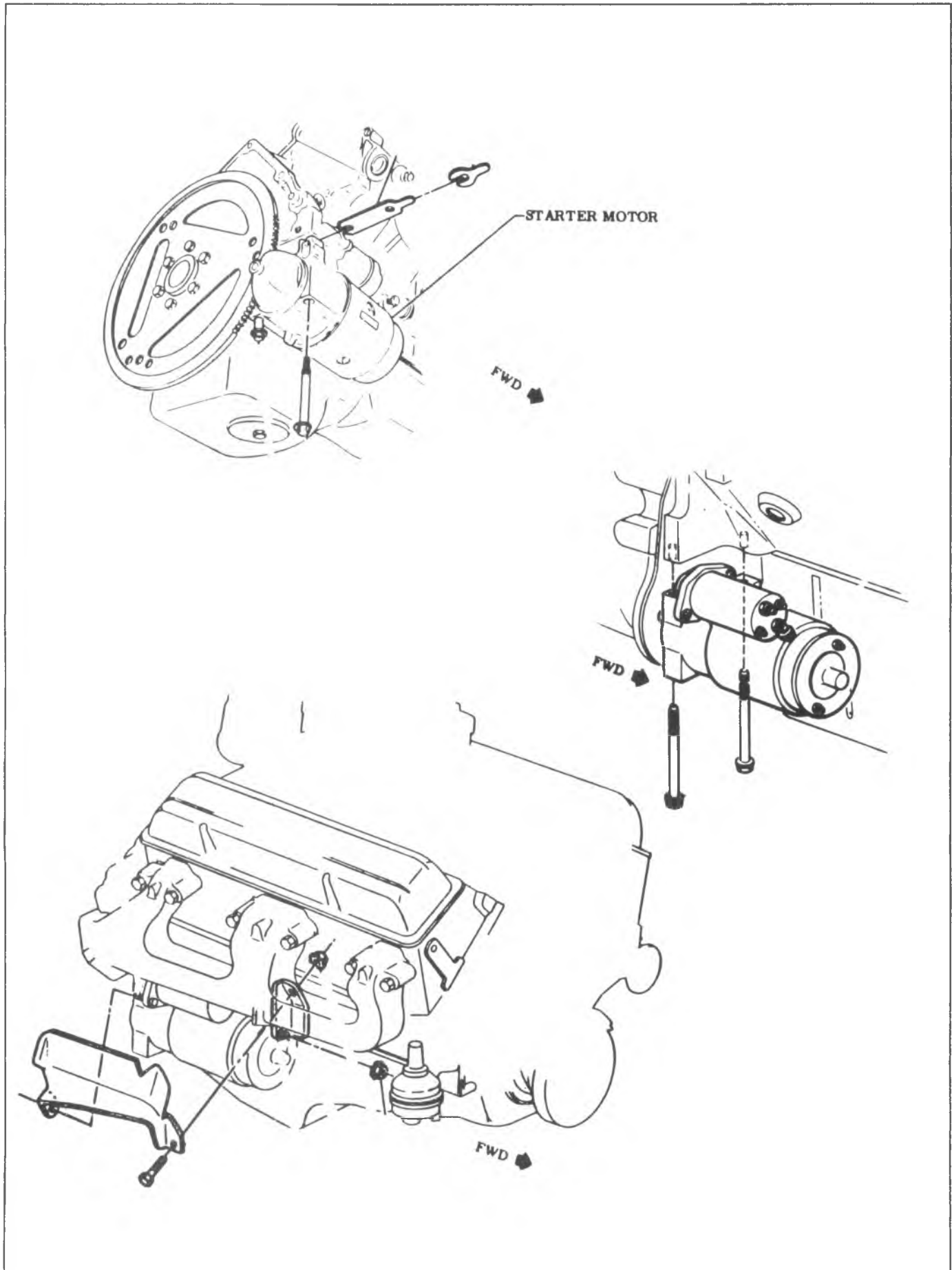

Fig. 6D-83--Starter Motor Mounting

## ON-VEHICLE SERVICE

Starting motors do not require lubrication except during overhaul.

When the motor is disassembled for any reason, lubricate as follows:

1. The armature shaft and drive end and commutator end bushings should be coated with no. 1960954 lubricant or equivalent.
2. The roll type overrunning clutch requires no lubrication. However, the drive assembly should be wiped clean. Do not clean in any degreasing tank or with grease dissolving solvents; this will dissolve the lubricant in the clutch mechanism. Use silicon grease General Electric CG321, Dow Corning 33 Medium or equivalent, on the shaft underneath the overrunning clutch assembly.

### REMOVE AND REPLACE

#### Starter (Fig. 6D-83)

Use the following procedure to remove the starter:

1. Disconnect negative battery lead at battery.

2. Raise vehicle.
3. Remove starter braces, shields, etc., that may be in the way.
4. Remove two starter motor to engine bolts, and allow starter to drop down.
5. Remove solenoid wires and battery cable and remove starter.
6. To replace, reverse the above procedure. Insure that any shims removed are replaced.

#### Solenoid

Use the following procedure to remove the solenoid from the starter:

1. Disconnect field strap.
2. Remove solenoid to drive housing attaching screws, motor terminal bolt, and remove solenoid by twisting.
3. Replace by reversing above procedures.



## UNIT REPAIR

## 5MT, 10MT, 25MT AND 27MT STARTER MOTORS DISASSEMBLY, TEST AND REASSEMBLY (STARTER REMOVED FROM ENGINE)

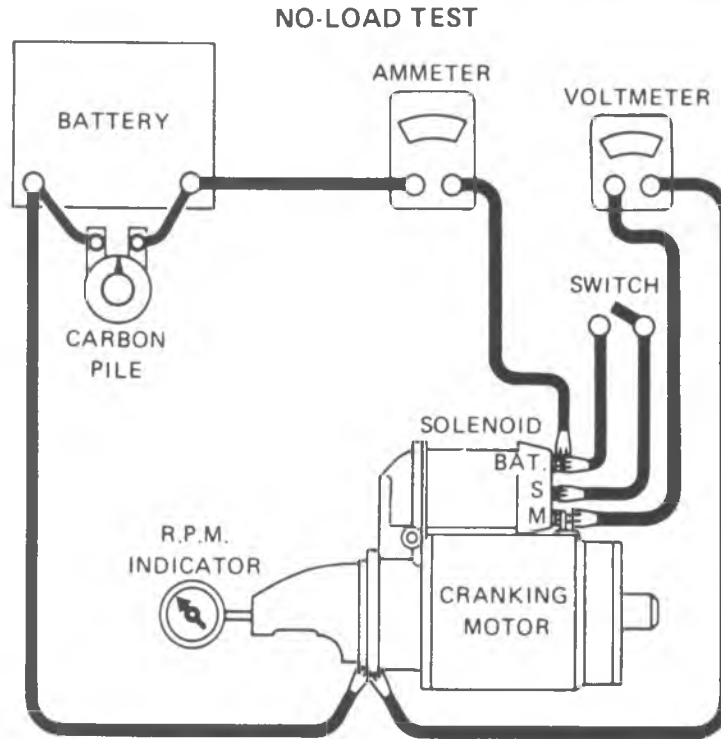

With the starter motor removed from the engine, the pinion should be checked for freedom of operation by turning it on the screw shaft. The armature should be checked for freedom of rotation by prying the pinion with a screwdriver. If the armature does not turn freely, the motor should be disassembled immediately. However, if the armature does rotate freely, the motor should be given a no-load test before disassembly.

Make connections as shown. Close the switch and compare the RPM, current, and voltage readings with the specifications. If the specified current draw does not include the solenoid, deduct from the ammeter reading the specified current draw of the solenoid hold-in winding. Make disconnections only with the switch open. Use the test results as follows:

**1. Rated current draw and no-load speed indicates normal condition of the starter motor.**

**2. Low free speed and high current draw indicates:**

- Too much friction — tight, dirty, or worn bearings, bent armature shaft allowing armature to drag.
- Shorted armature. This can be further checked on a growler after disassembly.
- Grounded armature or fields. Check further after disassembly.

**3. Failure to operate with high current draw indicates:**

- A direct ground in the terminal or fields.
- "Frozen" bearings (this should have been determined by turning the armature by hand).

**4. Failure to operate with no current draw indicates:**

- Open field circuit. This can be checked after disassembly by inspecting internal connections and tracing circuit with a test lamp.

- Open armature coils. Inspect the commutator for badly burned bars after disassembly.

- Broken brush springs, worn brushes, high insulation between the commutator bars or other causes which would prevent good contact between the brushes and commutator.

**5. Low no-load speed and low current draw indicates:**

- High internal resistance due to poor connections, defective leads, dirty commutator and causes listed under Number 4.

**6. High free speed and high current draw usually indicate shorted fields. If shorted fields are suspected, replace the field coil assembly. Also check for shorted armature, using a growler.**

Fig. 6D-84--Starter Unit Repair 1 of 6

**STARTER DISASSEMBLY**

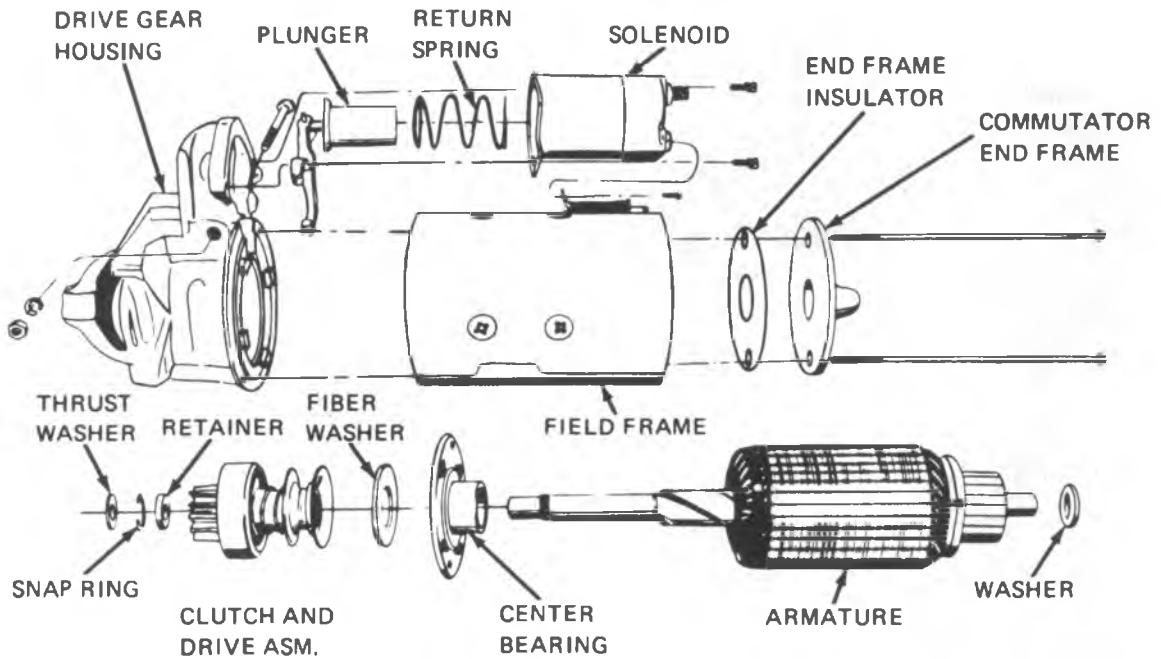

7. Remove screw from field coil connector and solenoid mounting screws. Rotate solenoid 90° and remove along with plunger return spring. Solenoid may now be serviced without further starter disassembly at this time.

8. Remove 2 through bolt, then remove commutator end frame (diesel only, remove insulator) and washer.  
 9. Remove field frame assembly from drive gear housing. (On diesel starter, armature remains in drive end frame.)

**SHIFT LEVER AND PLUNGER REMOVAL**

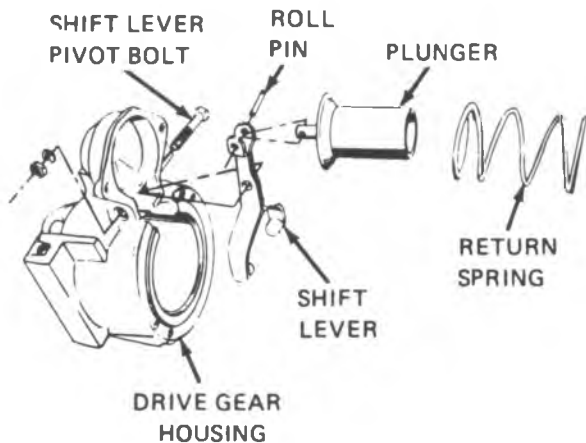

Steps 10 and 11 are required only on diesel starters.  
 10. Remove shift lever pivot bolt.  
 11. Remove center bearing screws (25 MT only) and remove drive gear housing from armature shaft. Shift lever and plunger assembly will now fall away from starter clutch.

**REMOVE DRIVE ASSEMBLY FROM SHAFT**

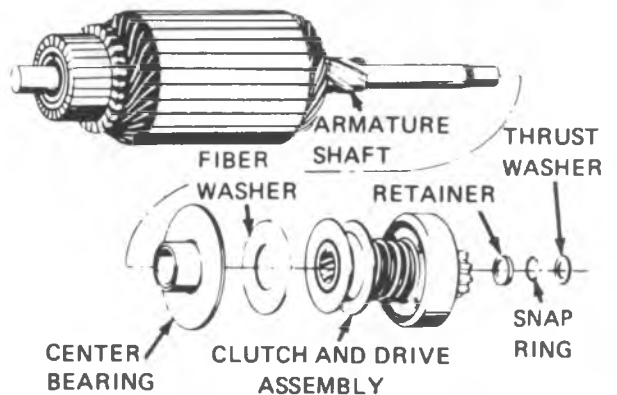

12. If necessary to remove overrunning clutch from armature shaft, proceed as follows:  
 a. Remove thrust washer or collar from armature shaft.  
 b. Slide a 5/8" deep socket or piece of pipe of suitable size over shaft against retainer as a driving tool. Tap tool to move retainer off snap ring.  
 c. Remove snap ring from groove in shaft. If snap ring is distorted, it will be necessary to use a new one on reassembly.  
 d. Remove retainer, clutch assembly (also fiber washer and center bearing on diesel) from armature shaft.  
 13. The shift lever and plunger may be disassembled at this time by removing the roll pin.

Fig. 6D-85--Starter Unit Repair 2 of 6

**REPLACE BRUSH HOLDER**

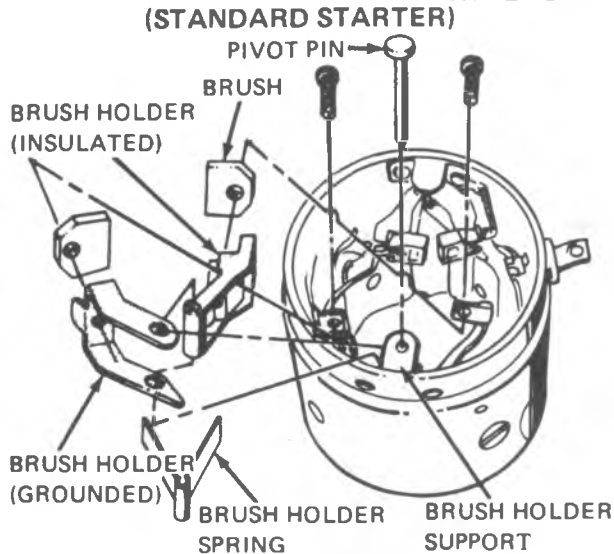

14. If necessary to replace brush holder parts, proceed as follows:

- a. Remove brush holder pivot pin which positions one insulated and one grounded brush.
- b. Remove brush spring.
- c. Replace brushes as necessary.

**(SMALL 5MT STARTER)**

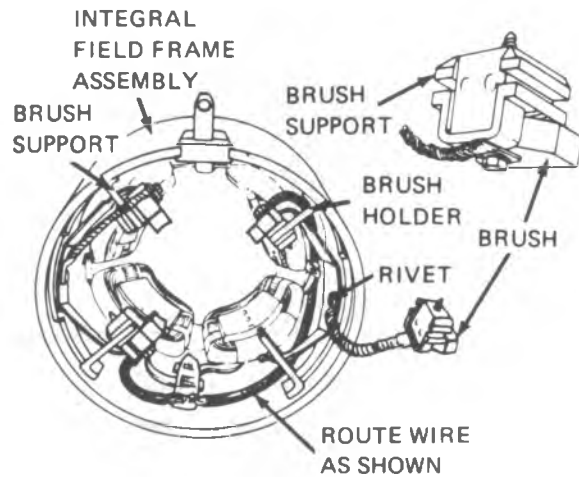

- a. Remove brush holder from brush support.
- b. Remove screw from brush holder and separate brush and holder.
- c. Inspect brush holder for wear or damage.
- d. Replace brushes and/or holders as necessary.

**CLEANING INSPECTION AND TESTS**

**TESTING SHUNT COIL FOR OPEN**

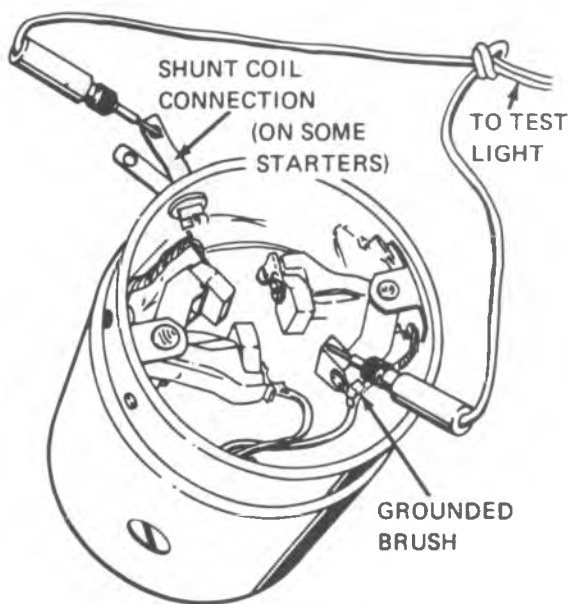

15. Clean all starting motor parts, but **DO NOT USE GREASE DISSOLVING SOLVENTS FOR CLEANING THE OVERRUNNING CLUTCH, ARMATURE, AND FIELD COILS**, solvent would dissolve the grease packed in the clutch and would damage armature and field coil insulation.

16. Inspect armature commutator, shaft and bushings, overrunning clutch pinion, brushes and springs for discoloration, damage or wear. Replace as required.

17. Check fit of armature shaft in bushing in drive housing. Shaft should fit snugly in the bushing. If the bushing is worn, it should be replaced.

18. Inspect armature commutator. If commutator is rough, it should be turned down. Do not undercut or turn to less than 1.650" O.D. Do not turn out-of-round commutators. Inspect the points where the armature conductors join the commutator bars to make sure they have a good connection. A burned commutator bar is usually evidence of a poor connection.

19. If test equipment is available:

a. Check the armature for short circuits by placing on growler and holding hack saw blade over armature core while armature is rotated. If saw blade vibrates, armature is shorted. Recheck after cleaning between the commutator bars. If saw blade still vibrates, replace the armature.

b. Using a test lamp, place one lead on the shunt coil terminal and connect the other lead to a ground brush. This test should be made from both ground brushes to insure continuity through both brushes and leads. If the lamp fails to light, the field coil is open and will require replacement.

**TESTING SERIES COIL FOR OPEN**

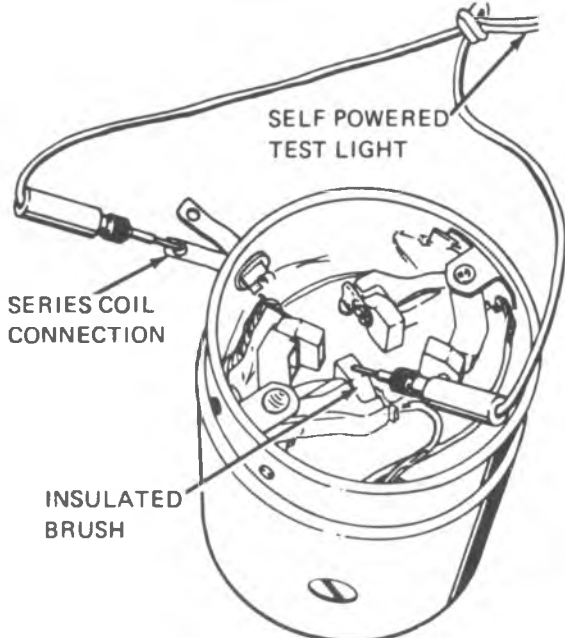

c. Using a test lamp, place one lead on the series coil terminal and the other lead on the insulated brush. If the lamp fails to light, the series coil is open and will require repair or replacement. This test should be made from each insulated brush to check brush and lead continuity.

**TESTING SERIES COIL FOR GROUND**

THESE TWO TERMINALS MUST BE SEPARATED AND NOT TOUCHING A GROUND DURING TEST

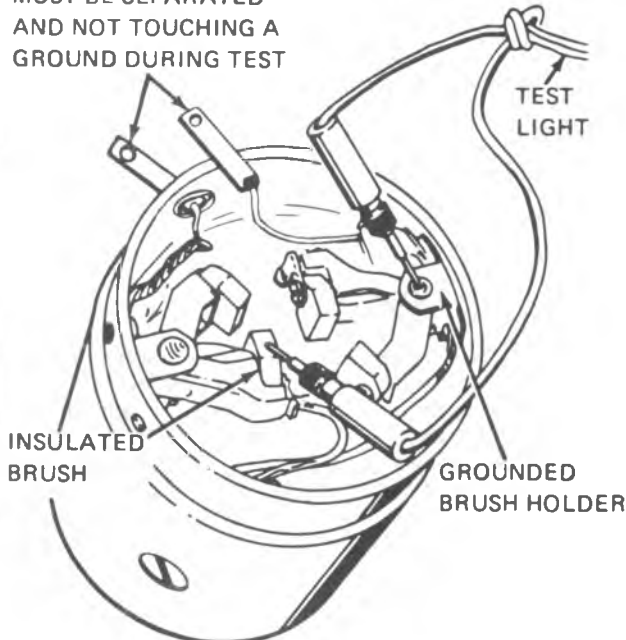

d. On starters with shunt coil, separate series and shunt coil strap terminals during this test. Do not let strap terminals touch case or other ground. Using a test lamp place one lead on the grounded brush holder and the other lead on either insulated brush. If the lamp lights, a grounded series coil is indicated and must be repaired or replaced.

**TESTING SOLENOID WINDINGS**

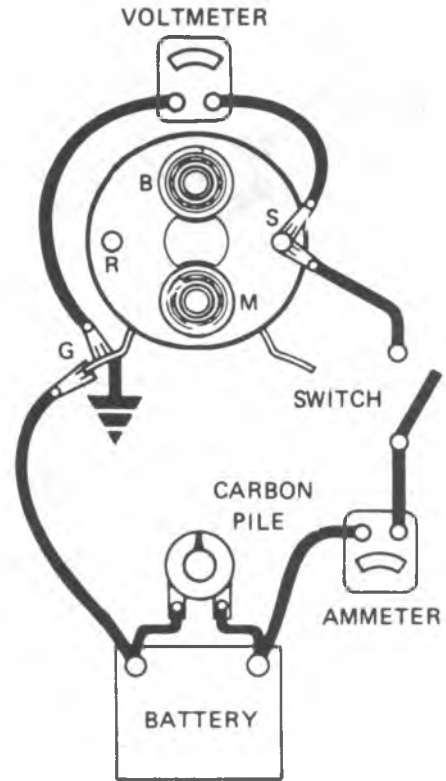

e. Check the current draw of the solenoid winding as follows:

If solenoid is not removed from starting motor, the connector strap terminals must be removed from the terminal on the solenoid before making these tests. Complete tests in a minimum of time to prevent overheating of the solenoid.

To check hold-in winding, connect an ammeter in series with 12-volt battery and the "switch" terminal on the solenoid. Connect a voltmeter to the "switch" terminal and to ground. Connect carbon pile across battery. Adjust the voltage to 10 volts and note the ammeter reading. It should be 14.5 to 16.5 amperes for all starting motors.

To check both windings, connect as for previous test. Ground the solenoid motor terminal. Adjust the voltage to 10 volts and note the ammeter reading. It should be 41 to 47 amperes for all starting motors.

NOTE: Current will decrease as windings heat up.

Current draw readings that are over specifications indicate shorted turns or a ground in the windings of the solenoid and the solenoid should be replaced. Current draw readings that are under specifications indicate excessive resistance. No reading indicates an open circuit. Check connections then replace solenoid if necessary.

Fig. 6D-87--Starter Unit Repair 4 of 6

## SOLENOID SWITCH DISASSEMBLY

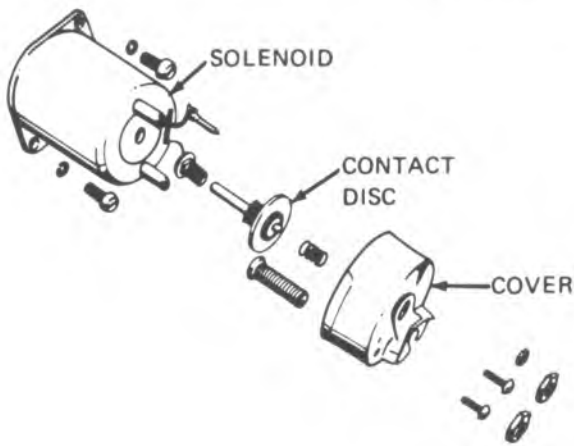

f. The starter solenoid switch is serviced as an assembly. The cover can be removed to inspect the contacts and contact disc if necessary.

## STARTER ASSEMBLY

## INSTALLING RETAINER, WASHER AND RING

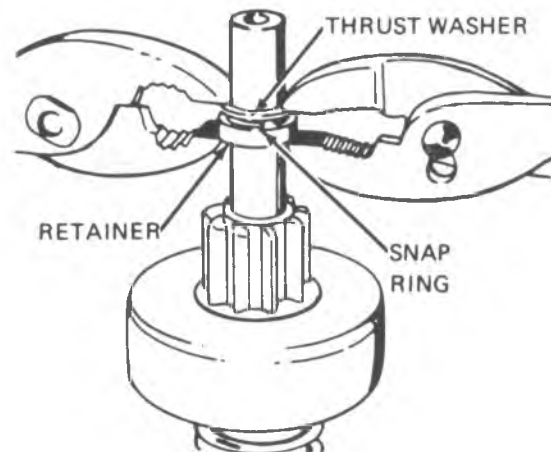

20. Assemble the armature and clutch as follows:

a. Lubricate drive end of armature shaft with lubricant 1960954 or equivalent.

b. Install center bearing (diesel starters) with bearing toward the armature winding. Then install the fiber washer on the armature shaft.

c. Slide clutch assembly onto armature shaft with pinion away from armature.

d. Slide retainer onto shaft with cupped side facing the end of shaft.

e. Install snap ring into groove on armature shaft.

f. Install thrust washer on shaft.

g. Position retainer and thrust washer with snap ring in between. Using two pliers, grip retainer and thrust washer or collar and squeeze until snap ring is forced into retainer and is held securely in groove in armature shaft.

21. Lubricate drive gear housing bushing with lubricant 1960954 or equivalent.

22. Engage shift lever yoke with clutch and slide complete assembly into drive gear housing.

On non-diesel starters the shift lever may be installed in drive gear housing first.

23. Install the center bearing screws (25 MT diesel only) and the shift lever pivot bolt. Tighten securely.

24. Install solenoid assembly.

25. Apply sealer, No. 1050026 or equivalent to solenoid flange where field frame contacts it.

26. Position field frame against drive gear housing on alignment pin using care to prevent damage to brushes.

27. Lubricate commutator end-frame bushing with lubricant 1960954 or equivalent.

28. Install washer on armature shaft and slide end frame onto shaft, then install and tighten through-bolts. On diesel starter, install insulator and then end frame onto shaft. Then install through bolts, making sure they pass through bolt holes in insulator.

29. Connect the field coil connector to the solenoid terminal.

30. Check pinion clearance as outlined under PINION CLEARANCE.

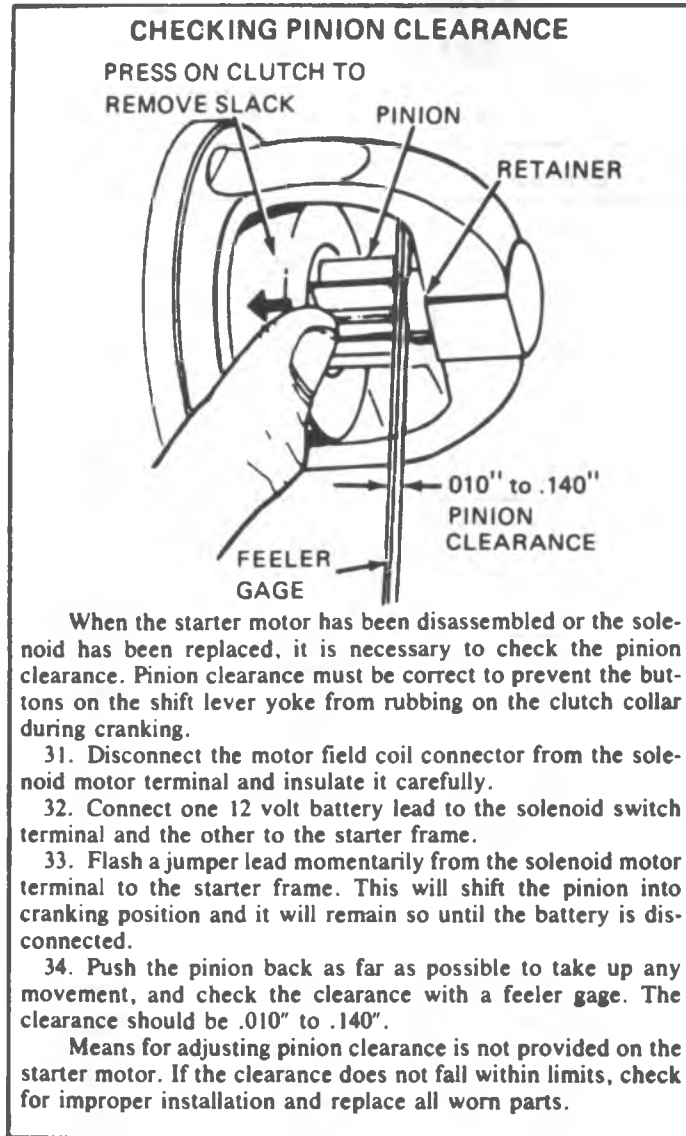

Fig. 6D-89--Starter Unit Repair 6 of 6

## SPECIFICATIONS GENERATOR

### CK PICK-UP & BLAZER

| Engine     | Generator | P/N     | Model | Rating |
|------------|-----------|---------|-------|--------|
| LE3        | K85       | 1100203 | 10SI  | 37A    |
| LE3        | K81       | 1100209 | 12SI  | 66A    |
| L25 (-N41) | K85       | 1100225 | 10SI  | 37A    |
| L25 (&N41) | K85       | 1100203 | 10SI  | 37A    |
| L25 (-N41) | K81       | 1100242 | 12SI  | 66A    |
| L25 (&N41) | K81       | 1100207 | 12SI  | 66A    |
| V-8 Gas    | K85       | 1100204 | 10SI  | 37A    |
| V-8 Gas    | K81       | 1100208 | 12SI  | 66A    |
| Diesel     | K81       | 1100241 | 12SI  | 66A    |

### CK SUBURBAN

| Engine | Generator | P/N     | Model | Rating |
|--------|-----------|---------|-------|--------|
| Gas V8 | K85       | 1100204 | 10SI  | 37A    |
|        | K81       | 1100208 | 12SI  | 66A    |
|        | K64       | 1100217 | 12SI  | 78A    |
| Diesel | K81       | 1100241 | 12SI  | 66A    |
|        | K64       | 1100259 | 12SI  | 78A    |

### G-VAN

| Engine | Generator | P/N     | Model | Rating |
|--------|-----------|---------|-------|--------|
| LE3    | K85       | 1100203 | 10SI  | 37A    |
| LE3    | K81       | 1100207 | 12SI  | 66A    |
| V8 Gas | K85       | 1100204 | 10SI  | 37A    |
| V8 Gas | K81       | 1100208 | 12SI  | 66A    |
| Diesel | K81       | 1100241 | 12SI  | 66A    |

### P-TRUCK

| Engine  | Generator | P/N     | Model | Rating |
|---------|-----------|---------|-------|--------|
| L25     | K79       | 1100229 | 10SI  | 42A    |
| L25     | K81       | 1100209 | 12SI  | 66A    |
| L25     | K97       | 1101064 | 27SI  | 80A    |
| LT9/LE8 | K79       | 1100231 | 10SI  | 42A    |
| LT9/LE8 | K81       | 1100208 | 12SI  | 66A    |
| LT9/LE8 | K97       | 1101063 | 27SI  | 80A    |
| LL4     | K81       | 1100241 | 12SI  | 66A    |
| LL4     | K64       | 1100293 | 15SI  | 85A    |

## BATTERY

| MODEL NO. | APPLICATION  | COLD CRANK RATE<br>@ 0°F (-18°C) | 25 AMP RESERVE<br>CAPACITY (MINUTES) |
|-----------|--|----------------------------------|--------------------------------------|
| 70-315    | ALL LE3  | 315 AMPS                         | 75                                   |
| 70-405    | L25,V8 GAS (C&K)                                     | 405                              | 75                                   |
| 71-390    | ALL GAS (P)<br>V8 GAS (G)                            | 390                              | 90                                   |
| X515      | TP2 BASE } (CKG)<br>UAI ALL GAS }<br>UAI ALL GAS (P) | 515                              | 115                                  |
| X550      | DIES. BASE (2) CKGP                                  | 550                              | 115                                  |
| 1200      | B3M (GAS) (P-BASE)                                   | 475                              | 130                                  |
| 1110      | B3M (GAS) (P-UAI)                                    | 625                              | 160                                  |

## STARTING MOTOR

| TRUCK | ENGINES                         | STARTER | MODEL   | SPEC. NO. | NO LOAD TEST @ 10 VOLTS * |      |      |       |
|-------|---------------------------------|---------|---------|-----------|---------------------------|------|------|-------|
|       |                                 |         |         |           | AMPS                      |      | RPM  |       |
|       |                                 |         |         |           | MIN.                      | MAX. | MIN. | MAX.  |
| C     | LE9/LF3                         | 1109535 | 5MT III | C3591     | 45                        | 70   | 7000 | 11900 |
| C     | LS9/LT9                         | 1998241 | 10MT    | C3589     | 65                        | 95   | 7500 | 10500 |
| C     | LE3/L25                         | 1998244 | 10MT    | C3592     | 60                        | 85   | 6800 | 10300 |
| C     | LH6/LL4                         | 1109563 | 27MT    | C7100     |                           |      |      |       |
| C     | LE8                             | 1998243 | 10MT    | C3563     | 65                        | 95   | 7500 | 10500 |
| C     | LF5 & 9B5                       | 1998211 | 10MT    | C3563     | 65                        | 95   | 7500 | 10500 |
| K     | LE9/LS9/LE3/L25/LT9             | 1998396 | 10MTM   | C3589     | 70                        | 110  | 6500 | 10700 |
| K     | LE8                             | 1998397 | 10MTM   | C3563     | 70                        | 110  | 6500 | 10700 |
| K     | LH6/LL4                         | 1109563 | 27MT    | C7100     | 120                       | 210  | 9000 | 13400 |
| G     | LE3                             | 1998244 | 10MT    | C3592     | 60                        | 85   | 6800 | 10300 |
| G     | LF3/LE9/LS9/LT9                 | 1998244 | 10MT    | C3589     | 65                        | 95   | 7500 | 10500 |
| G     | LH6/LL4                         | 1109563 | 27MT    | C7100     |                           |      |      |       |
| G     | LF5 & 9B5                       | 1998211 | 10MT    | C3563     | 65                        | 95   | 7500 | 10500 |
| P     | L25                             | 1998244 | 10MT    | C3592     | 60                        | 85   | 6800 | 10300 |
| P     | LT9 (EXC P30042<br>& JF9 & M20) | 1998241 | 10MT    | C3589     | 65                        | 95   | 7500 | 10500 |
| P     | LT9 (P30042 &<br>JF9 & M20)     | 1998245 | 10MT    | C3589     | 65                        | 95   | 7500 | 10500 |
| P     | LE8                             | 1998243 | 10MT    | C3563     | 65                        | 95   | 7500 | 10500 |
| P     | LL4                             | 1109563 | 27MT    | C7100     | 120                       | 210  | 9000 | 13400 |

\* Includes Solenoid Current

104017



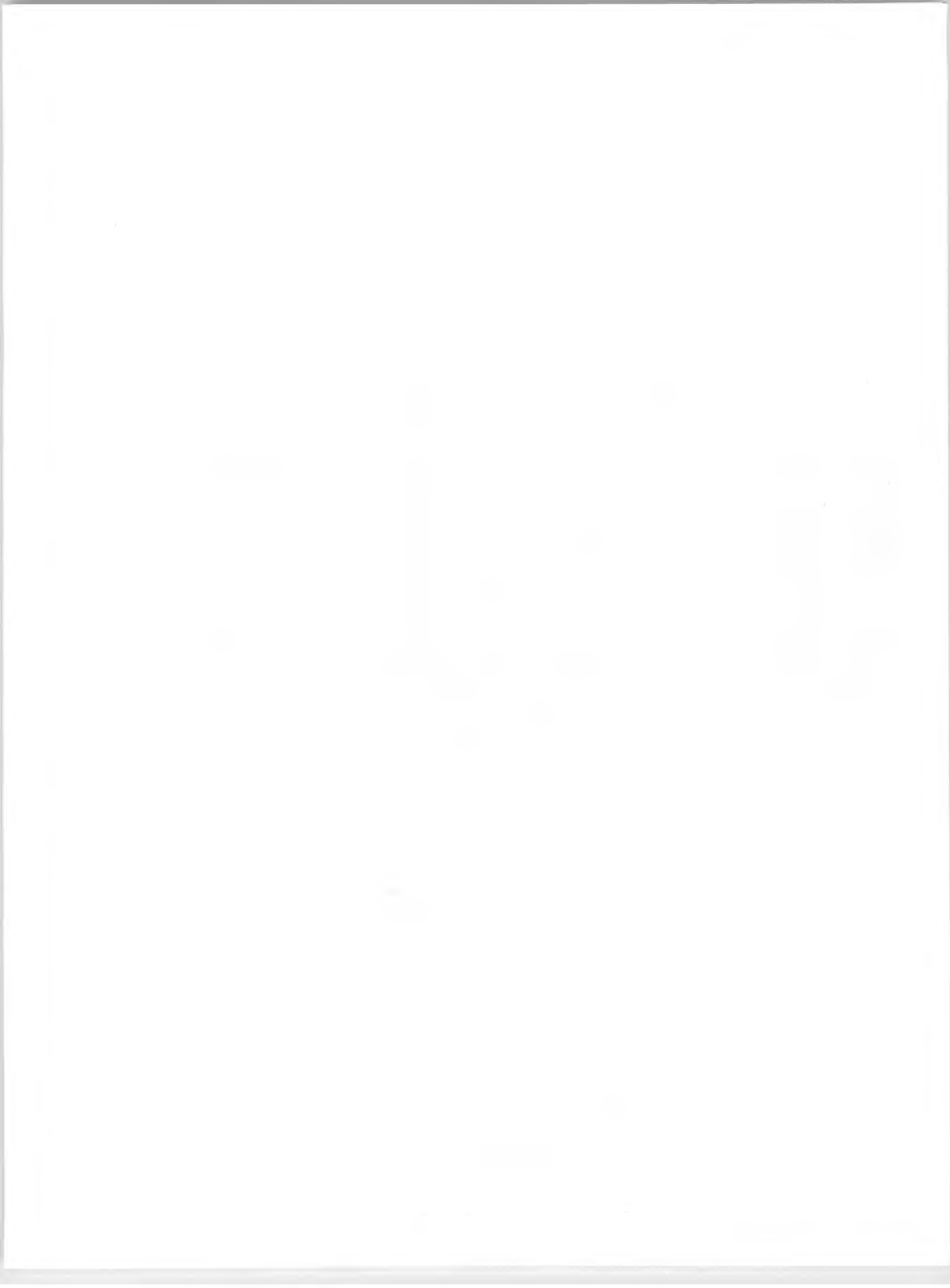

## SECTION 6E1

# EMISSION CONTROLS - CARBURETOR

### CONTENTS

|   |        |  |        |
|---|--------|--|--------|
| General Description.....                        | 6E1- 1 | Diagnostic Procedure.....                | 6E1-20 |
| Vehicle Emission Control Information Label..... | 6E1- 2 | Diagnostic Circuit Check .....           | 6E1-20 |
| Emission Test.....                              | 6E1- 2 | System Performance Check .....           | 6E1-20 |
| Explanation of Abbreviations.....               | 6E1- 2 | Tools and Equipment.....                 | 6E1-20 |
| Positive Crankcase Ventilation.....             | 6E1- 5 | Trouble Code Identification .....        | 6E1-20 |
| Thermostatic Air Cleaner .....                  | 6E1- 6 | Remote Lamp Driver.....                  | 6E1-21 |
| Exhaust Gas Recirculation.....                  | 6E1- 9 | On-Vehicle Service .....                 | 6E1-22 |
| Early Fuel Evaporation .....                    | 6E1-13 | Electronic Control Module (ECM) .....    | 6E1-22 |
| Computer Command Control.....                   | 6E1-15 | Vacuum Sensor .....                      | 6E1-58 |
| General .....                                   | 6E1-15 | Component Locations .....                | 6E1-22 |
| Diagnostic Procedure.....                       | 6E1-18 | Wiring Harness.....                      | 6E1-55 |
| Trouble Code "Test" Lead.....                   | 6E1-18 | Fuel Control System.....                 | 6E1-56 |
| Trouble Code Memory .....                       | 6E1-18 | Air Injection Reaction (AIR) .....       | 6E1-59 |
| Trouble Code Clearing .....                     | 6E1-18 | Evaporative Emission Control System..... | 6E1-68 |
| PROM Replacement .....                          | 6E1-19 | Electronic Spark Timing .....            | 6E1-72 |
|   |        | Transmission Converter Clutch.....       | 6E1-75 |

ALL NEW GENERAL MOTORS VEHICLES ARE CERTIFIED BY THE UNITED STATES ENVIRONMENTAL PROTECTION AGENCY AS CONFORMING TO THE REQUIREMENTS OF THE REGULATIONS FOR THE CONTROL OF AIR POLLUTION FROM NEW MOTOR VEHICLES. THIS CERTIFICATION IS CONTINGENT ON CERTAIN ADJUSTMENTS BEING SET TO FACTORY STANDARDS. IN MOST CASES, THESE ADJUSTMENT POINTS EITHER HAVE BEEN PERMANENTLY SEALED AND/OR MADE INACCESSIBLE TO PREVENT INDISCRIMINATE OR ROUTINE ADJUSTMENT IN THE FIELD. FOR THIS REASON, THE FACTORY PROCEDURE FOR TEMPORARILY REMOVING PLUGS, CAPS, ETC., FOR PURPOSES OF SERVICING THE PRODUCT MUST BE STRICTLY FOLLOWED AND, WHEREVER PRACTICABLE, RETURNED TO THE ORIGINAL INTENT OF THE DESIGN.

### GENERAL DESCRIPTION

- The gasoline engine emission control systems include:
- Catalytic Converter - Reduces pollutants from the exhaust gas stream. Refer to Section 6F, Exhaust System, for catalytic converter diagnosis and service information.
  - Positive Crankcase Ventilation (PCV) - Prevents fumes in the crankcase from passing into the atmosphere which contain unburned hydrocarbons. Diagnosis and service information are in this section.
  - Thermostatic (THEMAC) Air Cleaner - Provides preheated air to enter the carburetor which gives good driveability and eliminates throttle blade icing. Diagnosis and service information are in this section.
  - Exhaust Gas Recirculation (EGR) - Used to lower NOx emission levels by feeding small amounts of exhaust gas back into the combustion chamber which lowers combustion temperatures and in turn lowers NOx emission levels. Diagnosis and service information are in this section.
  - Early Fuel Evaporation (EFE) - Provides a rapid heat source to the engine induction system which aids cold driveability. Diagnosis and service information are in this section.
  - Air Injection Reactor - Injects air into the exhaust during cold engine operation to help the catalytic converter reach proper operating temperature. Diagnosis and service information are in this section.
  - Evaporative Emission Control (EEC) - Prevents gasoline vapors in the fuel tank and carburetor from entering the atmosphere. Diagnosis and service are in this section.
  - Computer Command Control (California Only) - Has an Electronic Control Module (ECM) which is a computer that electrically controls and monitors emission systems. Diagnosis and service information are in this section. The following engines have an ECM that control and monitor:

1. **4.1L - VIN D**

- Air/fuel mixture in the carburetor
- Air Injection Reactor
- EST
- TCC

2. **5.0L - VIN F**

- Air/fuel mixture in the carburetor
- Air Injection Reactor
- Evaporative Emission Control
- EST
- TCC

3. **5.71 - VIN L**

- Air/fuel mixture in the carburetor
- Air Injection Reactor
- Evaporative Emission Control
- EST
- TCC

**VEHICLE EMISSION CONTROL INFORMATION LABEL**

The Vehicle Emission Control Information label (Fig. 6E1-1) is located in the engine compartment (fan shroud, radiator support, hood underside, etc.) of every vehicle produced by General Motors Corporation. The label contains important emission specifications and setting procedures, as well as a vacuum hose schematic with emission components identified.

When servicing the engine or emission systems, the Vehicle Emission Control Information label should be checked for up-to-date information.

**EMISSION TEST**

Refer to Figure 6E1-2 for possible causes of emission test failure.

**EXPLANATION OF ABBREVIATIONS**

ALCL - Assembly Line Communications Link (Under-Dash Connector)

AIR - Air Injection Reactor

AMP - Ampere

A.T. - Automatic Transmission

BAT - Battery Positive Terminal

BARO - Barometric Pressure

CALIF. - California

C.E. - Check Engine

CO - Carbon Monoxide

CONV. - Converter

EAC - Electric Air Control

EAS - Electric Air Switching

ECM - Electronic Control Module

EDV - Electric Divert Valve

EECS - Evaporative Emission Control System

EFE - Early Fuel Evaporation

EGR - Exhaust Gas Recirculation

ESC - Electronic Spark Control

EST - Electronic Spark Timing

FED - Federal

HEI - High Energy Ignition

HG - Mercury

HC - Hydrocarbons

I.P. - Instrument Panel

IGN - Ignition

ISC - Idle Speed Control

M/C - Mixture Control

MAP - Manifold Absolute Pressure

M.T - Manual Transmission

NEG - Negative

NOx - Oxides of Nitrogen

P/N - Park/Neutral

PCV - Positive Crankcase Ventilation

PORT - Exhaust Ports

PROM - *ECM Calibration Unit (Programmable Read Only Memory)*

RPM - Revolutions per minute

TACH - Tachometer

TCC - Torque Converter Clutch

THERMAC - Thermostatic

TPS - Throttle Position Sensor

TVS - Thermal Vacuum Switch

TVV - Thermal Vacuum Valve

V - Volt

VAC - Vacuum

VIN - Vehicle Identification Number

VSS - Vehicle Speed Sensor

WOT - Wide Open Throttle

**LABEL CODE  
ENGINE SIZE  
EXHAUST EMISSION FAMILY  
EVAPORATIVE EMISSION FAMILY**

**ADJUSTMENT  
PROCEDURE**

**ENGINE ADJUSTMENT  
SPECIFICATIONS**

**CDJ**  
5.0 LITER  
\* C1G5.7T4HACS  
2D4D-8

**VEHICLE EMISSION CONTROL INFORMATION**  
GENERAL MOTORS CORPORATION 

**SET PARKING BRAKE AND BLOCK DRIVE WHEELS.**  
MAKE ALL ADJUSTMENTS WITH ENGINE AT NORMAL OPERATING TEMPERATURE, CHOKE FULL OPEN  
CLEANER INSTALLED, AND AIR CONDITIONING (A/C) OFF, EXCEPT WHERE NOTED.

1. DISTRIBUTOR: DISCONNECT AND PLUG VACUUM HOSE AT DISTRIBUTOR. ADJUST TIMING AT SPECIFIED ENGINE SPEED. UNPLUG AND RECONNECT VACUUM HOSE TO DISTRIBUTOR.
2. IDLE SPEED SCREW: DISCONNECT ELECTRICAL WIRE FROM IDLE SPEED SOLENOID. ADJUST CARBURETOR IDLE SPEED SCREW TO SPECIFIED RPM. RECONNECT ELECTRICAL WIRE TO IDLE SPEED SOLENOID.
3. IDLE SPEED SOLENOID: DISCONNECT ELECTRICAL WIRE FROM IDLE SPEED SOLENOID. START ENGINE WITHOUT TOUCHING THROTTLE. ADJUST IDLE SPEED TO SPECIFIED RPM. OPEN THROTTLE TO RELEASE THROTTLE STOP. UNPLUG AND RECONNECT VACUUM HOSE TO EGR VALVE. RECONNECT ELECTRICAL WIRE TO IDLE SPEED SOLENOID.
4. FAST IDLE: TURN FAST IDLE SWITCH ON HIGH STEP OF FAST IDLE CAM. START ENGINE WITHOUT TOUCHING THROTTLE. ADJUST FAST IDLE SCREW TO SPECIFIED RPM. OPEN THROTTLE TO RELEASE THROTTLE STOP. UNPLUG AND RECONNECT VACUUM HOSE TO EGR VALVE. RECONNECT ELECTRICAL WIRE TO FAST IDLE SWITCH.

**CATALYST**

|              |        |
|--------------|--------|
| REG/OC       |        |
| TRANSMISSION | MANUAL |
| 4° @ 600 (N) | 0.045  |
| 600 (N)      |        |
| 750 (N)      |        |
| 1300 (N)     |        |

**NOTE** IDLE MIXTURE SCREWS ARE PRESET AND SEALED AT FACTORY. PROVISION FOR ADJUSTMENT DURING TUNE UP IS NOT PROVIDED.  
SEE SERVICE MANUAL, MAINTENANCE SCHEDULE AND EMISSION HOSE ROUTING DIAGRAM FOR ADDITIONAL INFORMATION.

THIS VEHICLE HAS BEEN DESIGNED FOR PRINCIPAL USE AT LOW ALTITUDE. SEE SERVICE PUBLICATION FOR FURTHER INFORMATION.

THIS VEHICLE CONFORMS TO U.S. EPA REGULATIONS APPLICABLE TO MODEL YEAR NEW LIGHT-DUTY TRUCKS.

PT. NO. 14045807  
PRINTED IN U.S.A.

**LABEL PART  
NUMBER**

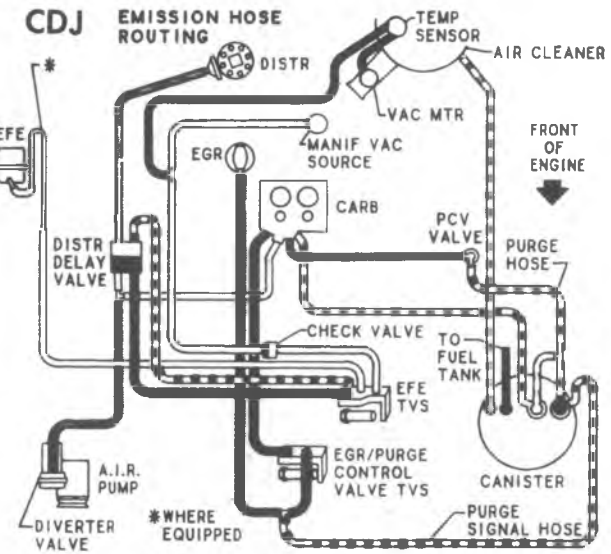

**EMISSION COMPONENT  
AND VACUUM HOSE SCHEMATIC**

## POSSIBLE CAUSES OF EMISSIONS TEST FAILURES

| EXCESSIVE EMISSIONS                   | EXPLANATION  | POSSIBLE CAUSES   |
|---------------------------------------|--|---|
| Hydrocarbons (HC) *                   | Excessive hydrocarbons are caused by an air fuel mixture that is not burning completely.       | <ul style="list-style-type: none"> <li>● Engine not at normal operating temperature.</li> <li>● Disconnected, obstructed, leaking, or mis-routed vacuum hoses.</li> <li>● Vacuum leaks.</li> <li>● Maladjusted idle speed.</li> <li>● Maladjusted idle mixture - if plugs are removed.</li> <li>● Maladjusted initial spark timing.</li> <li>● Spark plugs, wires or distributor cap.</li> <li>● Improper operation of AIR or Pulsair system.</li> <li>● Lead contamination of catalytic converter (check for absence of filler neck restrictor).</li> </ul>  |
| Carbon monoxide (CO) *                | Excessive carbon monoxide emissions are due to a mixture that is rich.                         | <ul style="list-style-type: none"> <li>● Engine not at normal operating temperature.</li> <li>● Maladjusted idle mixture if plugs are removed.</li> <li>● Improperly adjusted/sticking choke.</li> <li>● Stuck PCV valve or obstructed PCV hose.</li> <li>● Lead contamination of catalytic converter (check for absence of filler neck restrictor).</li> <li>● Improper operation of AIR or Pulsair system.</li> <li>● Leaking carburetor fuel passages or gaskets.</li> <li>● Carburetor float level.</li> <li>● Stuck carburetor power piston.</li> <li>● Restricted air cleaner element.</li> </ul> |
| Oxides of nitrogen (NO <sub>x</sub> ) | Excessive oxides of nitrogen are generally due to high temperatures in the combustion chamber. | <ul style="list-style-type: none"> <li>● Obstructed/leaking/misrouted vacuum lines.</li> <li>● Faulty EGR temperature sensor controls.</li> <li>● Improper operation of the EGR system.</li> <li>● Incorrect EGR valve for engine type.</li> <li>● Plugged EGR passages.</li> <li>● Inoperative Thermac.</li> <li>● Maladjusted initial spark timing.</li> <li>● Improper operation of distributor centrifugal or vacuum spark advance.</li> </ul>  |

\* Excessive emissions of both hydrocarbons and carbon monoxide are related to an extremely rich air/fuel mixture. A rich air/fuel mixture increases CO emissions, but if the mixture is too rich, it will not burn completely. This unburned fuel contributes to high hydrocarbon emissions. Check for possible causes as stated in the HC and CO section. Check co-related causes first.

Fig. 6E1-2--Possible Causes of Emission Test Failure

## POSITIVE CRANKCASE VENTILATION (PCV) SYSTEM

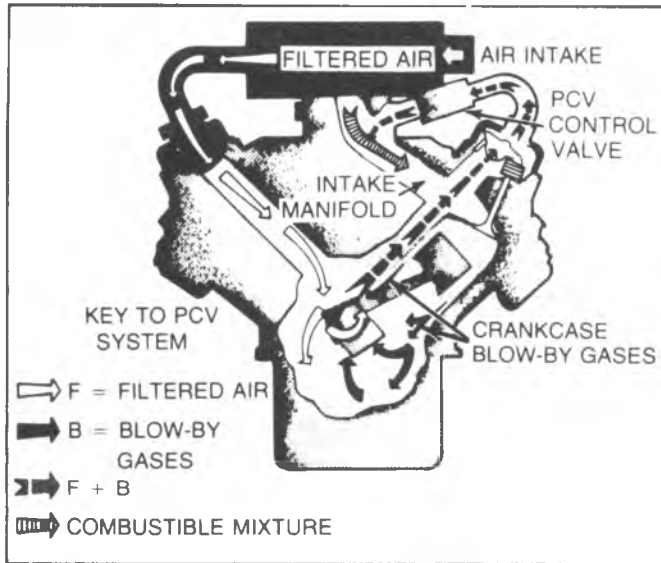

Fig. 6E1-3--PCV System Flow-Typical

The Positive Crankcase Ventilation (PCV) System provides more complete scavenging of crankcase vapors. Fresh air from the air cleaner is supplied to the crankcase, mixed with blow-by gases and then passed through a positive crankcase ventilation (PCV) valve into the induction system (Fig. 6E1-3).

The primary mode of crankcase ventilation control is through the PCV valve (Fig. 6E1-4) which meters the mixture of fresh air and blow-by gases into the induction system at a rate dependent upon manifold vacuum.

To maintain idle quality, the PCV valve restricts the ventilation system flow whenever intake manifold vacuum is high. If abnormal operating conditions arise, the system is designed to allow excessive amounts of blow-by gases to back flow through the intake tube into the air cleaner and through the carburetor to be consumed by normal combustion.

### DIAGNOSIS

Refer to Figure 6E1-5 for PCV System diagnosis.

### ON-VEHICLE SERVICE

#### General

An engine which is operated without any crankcase ventilation can be damaged seriously. Therefore, it is important to replace the PCV valve at intervals shown in Section 0B.

**NOTICE:** If an engine is idling too slow or rough, this may be caused by a clogged ventilator valve or plugged hose; therefore, never adjust the carburetor idle without first checking the PCV valve and hose.

With this system, any blow-by in excess of the system capacity (from a badly-worn engine, sustained heavy load, etc.) is exhausted into the air cleaner and is drawn into the engine.

Proper operation of the PCV System is dependent upon a sealed engine. If oil sludging or dilution is noted, and the PCV System is functioning properly, check engine for possible cause and correct to ensure that system will

### GENERAL

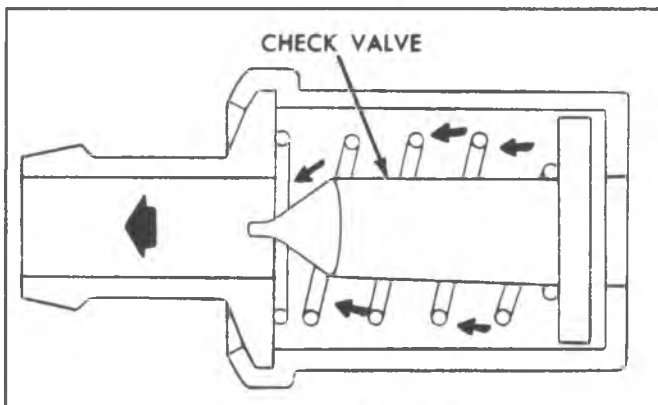

Fig. 6E1-4--PCV-Cross Section

#### CONDITION

Slow, unstable idle, frequent stalling.

Oil in air cleaner.

#### POSSIBLE CAUSE

Valve completely plugged or stuck.

Restricted filter

PCV system plugged.

Leak in closed ventilation system.

#### CORRECTION

Replace valve.

Replace filter, clean system.

Replace valve.

Clean system as required.

Inspect for leaks to atmosphere and correct as necessary.

Fig. 6E1-5--PCV System Diagnosis

function as intended.

### Function Test and Replacement

1. Remove PCV valve from intake manifold or rocker arm cover.
2. Run the engine at idle.
3. Place your thumb over end of the valve to check vacuum. If there is no vacuum at valve, check for plugged hoses or valve.

4. Shut off the engine. Shake valve and listen for the rattle of check needle in valve. If valve does not rattle, replace valve.
5. After installing a new PCV valve, check engine idle and readjust if necessary.

## THERMOSTATIC AIR CLEANER (THERMAC)

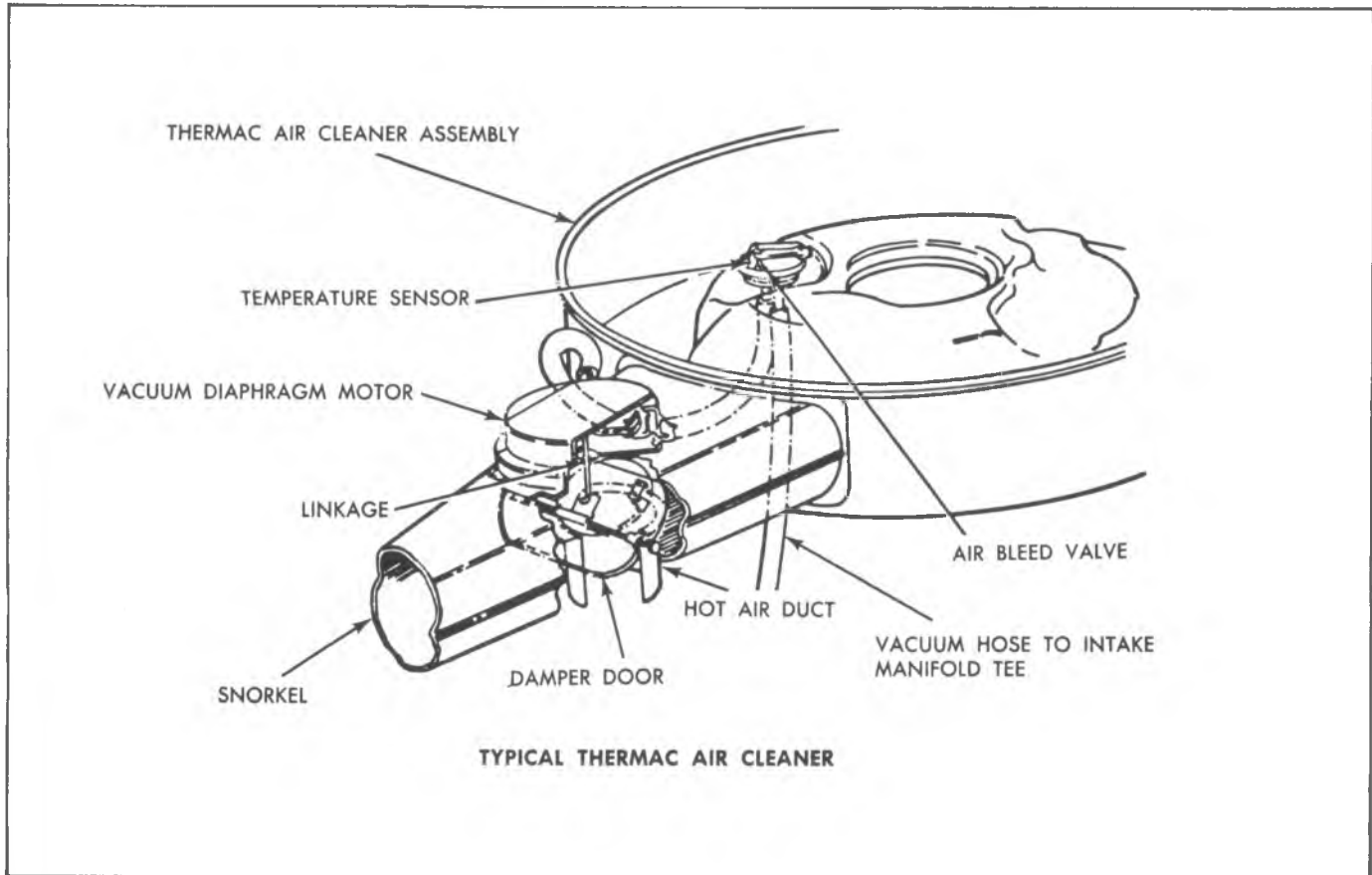

Fig. 6E1-6--THERMAC Air Cleaner-Typical

### GENERAL

A heated intake air system (Fig. 6E1-6) is used to give good driveability under various climatic conditions. By having a uniform inlet air temperature, the fuel system can be calibrated to reduce exhaust emissions and to eliminate throttle blade icing.

The THERMAC air cleaner operates by heated air and manifold vacuum (Fig. 6E1-7). Air can enter the air cleaner from outside the engine compartment or from a heat stove built around the exhaust manifold. A vacuum diaphragm motor, built into the air cleaner snorkel, moves a damper door to admit hot air from the exhaust manifold, outside air, or a combination of both. Inside the air cleaner is a temperature sensor that reacts to air intake temperature and controls the amount of vacuum going to the motor. When the temperature is below a calibrated value, the sensor allows vacuum to the motor and the damper door will be up, shutting off outside air and allowing only heated air from the exhaust manifold to enter the air cleaner. When

the temperature is above a calibrated value, the damper door drops down and only outside air enters the air cleaner. Between the low and high temperature, the damper door allows both heated and outside air to enter the air cleaner.

The vacuum connections at the bottom of the sensor have a large and small restriction. The small one goes to the vacuum source. Because it is small, it acts as a THERMAC vacuum trap or slow bleed off valve and during the warm-up, it prevents cold air from entering when vacuum drops suddenly on acceleration.

### DIAGNOSIS

#### Vacuum Motor Check

1. Check all hoses for proper hook-up. Check for kinked, plugged or damaged hoses.
2. With the engine "OFF", observe damper door position through snorkel opening. If position of snorkel makes observation difficult, use the aid of a mirror. At this point damper door should be in such a position that the heat stove passage is covered.

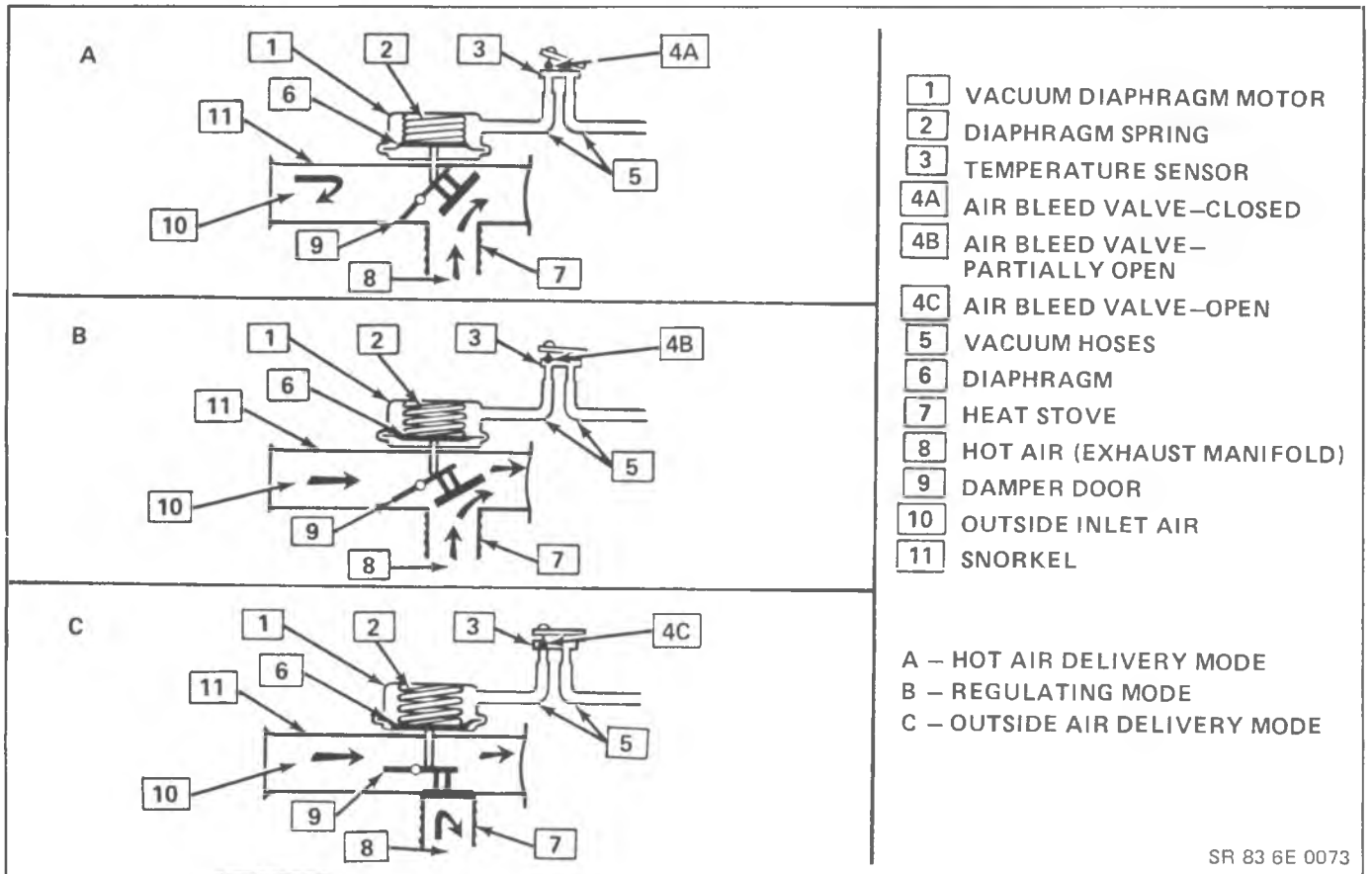

Fig. 6E1-7--THERMAC Operation

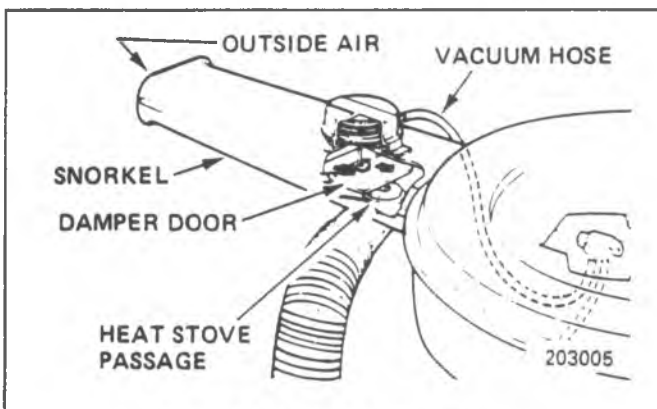

Fig. 6E1-8--Snorkel Passage Open

(snorkel passage open) (See Fig. 6E1-8). On some engines in cold temperatures, the damper door may be closed due to the use of a vacuum check or delay valve. Momentarily disconnect vacuum hose at THERMAC vacuum motor and observe damper position. If stove passage is not covered, check for binds in linkage.

- Apply at least 24 kPa (7" HG) of vacuum to the diaphragm assembly through hose disconnected at sensor unit. Damper door should completely close snorkel passage when vacuum is applied (See Fig. 6E1-9). If not, check to see if linkage is hooked up correctly and not binding and for a vacuum leak in diaphragm assembly. Replace diaphragm assembly.

## Temperature Sensor Check

### Quick Check

- Start test with engine cold, air cleaner at temperature below 25°C (77°F). If the engine has been in recent use, allow it to cool. (Removing the air cleaner from the engine and placing it on the bench will aid in quickly cooling the sensor.) Momentarily disconnect vacuum hose at THERMAC vacuum motor before proceeding with test.
- Check heated air pipe for proper installation. Proper operation of thermostatic air cleaner depends upon ample supply of heated air.
- Observe the damper door before starting the engine; it should be in the open snorkel position, Fig. 6E1-8.

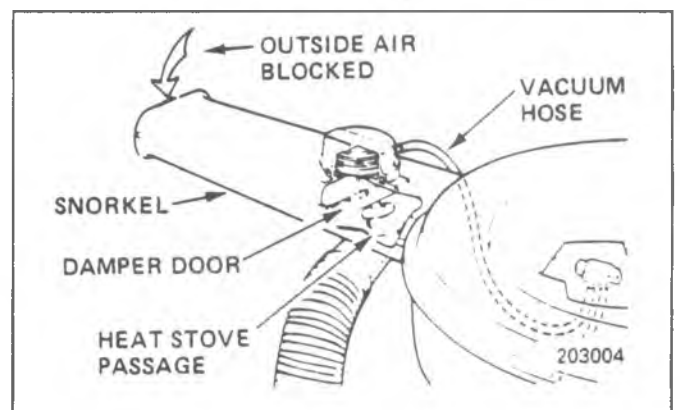

Fig. 6E1-9--Snorkel Passage Closed



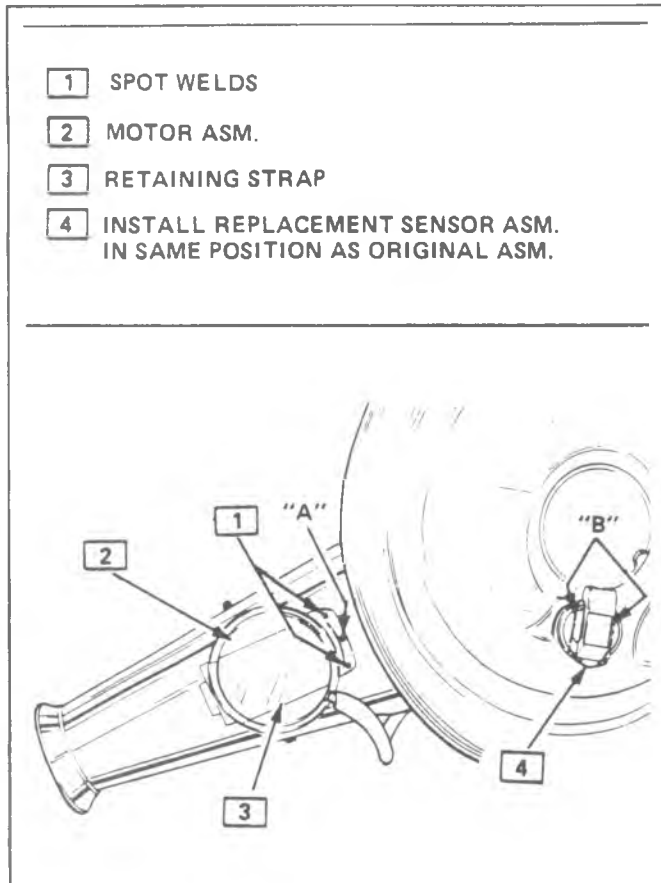

Fig. 6E1-10--Removing THERMAC Vacuum Motor

4. Start the engine and allow it to idle. Immediately after starting the engine, the damper door should be in the closed snorkel passage position, Fig. 6E1-9.
5. As the engine warms up, the damper door should start to allow outside air and heated air to enter the carburetor inlet.
6. The system is operating normally as described above. If the air cleaner fails to operate as above, or if correct operation of the air cleaner is still in doubt, proceed to the thermometer check of sensor.

#### Thermometer Check

1. Start test with air cleaner temperature below 25°C (77°F). If engine has been run recently, remove air cleaner and place on bench (this will help quickly cool the air cleaner). Remove air cleaner cover and place thermometer as close as possible to the sensor. Let air cleaner cool until thermometer reads below 26°C (79°F) about 5 to 10 minutes. Reinstall air cleaner on engine and continue to Step 2 below.
2. Start and idle engine. Damper door should move to close the snorkel passage immediately if engine is cool enough (Fig. 6E1-9). When damper door starts to open the snorkel passage (in a few minutes), remove air cleaner cover and read temperature gage. It must read 46°C (123°F), plus or minus 6°C (20°F).

3. If the damper door does not start to open the snorkel passage at temperature indicated, temperature sensor is malfunctioning and must be replaced.

## ON-VEHICLE SERVICE

### Vacuum Motor

#### Removal (Fig. 6E1-10)

1. Remove air cleaner.
2. Disconnect vacuum hose from motor.
3. Drill out the two spot welds initially with a 1/16" hole, then enlarge as required to remove the retaining strap. Do not damage the snorkel tube.
4. Remove motor retaining strap.
5. Lift up motor, cocking it to one side to unhook the motor linkage at the control damper assembly.

#### Installation

1. Drill a 7/64" hole in snorkel tube at point "A" as shown in Fig. 6E1-19.
2. Insert vacuum motor linkage into control damper assembly.
3. Use the motor retaining strap and sheet metal screw provided in the motor service package to secure the retaining strap and motor to the snorkel tube.
4. Make sure the screw does not interfere with the operation of the damper assembly. Shorten screw if required.
5. Connect vacuum hose to motor and install air cleaner.

### Sensor

#### Removal (Fig. 6E1-11)

1. Remove air cleaner.
2. Detach hoses at sensor. Note hose position for installation.
3. Pry up tabs on sensor retaining clip; remove clip and sensor from air cleaner. Note position of sensor for installation.

#### Installation

1. Install sensor and gasket assembly in original position.
2. Press retainer clip on hose connectors.
3. Connect vacuum hoses in, position noted at time of removal, and install air cleaner on engine.

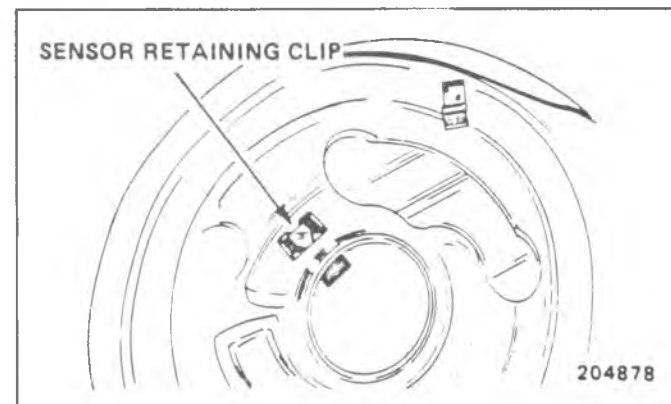

Fig. 6E1-11--Removing THERMAC Sensor Retaining Clip

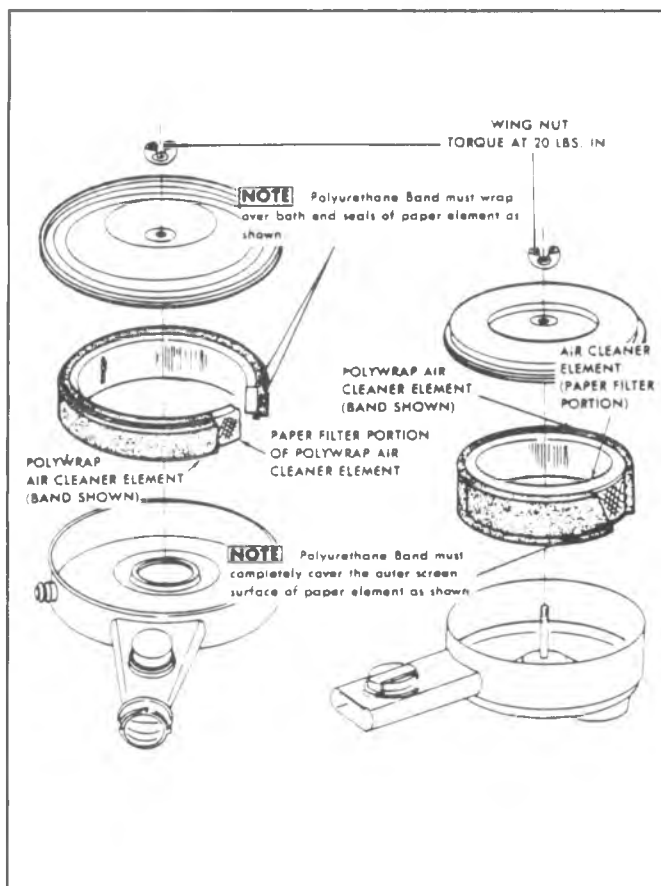

Fig. 6E1-12--Polywrap Air Cleaner-P-Truck

## Air Cleaner Element Replacement

### Paper Element

1. Remove air cleaner cover.
2. Remove element.
3. Install new element in air cleaner with either end up.
4. Install air cleaner cover. Do not over tighten nut.

### Polywrap Element (P Truck)

1. Remove air cleaner cover.
2. Remove element.
3. Remove polywrap band from paper element and discard element (Fig. 6E1-12).
4. Clean bottom section of air cleaner and inspect cover seal for tears or cracks. Replace seal if damaged.
5. Inspect band for tears and replace if damaged.
6. If band is serviceable, wash in kerosene or mineral spirits and squeeze out excess solvent.

**NOTICE:** Never use a hot degreaser or any solvent containing acetone or similar solvent; also, never shake, swing or wring the element to remove excess solvent as this may tear the polyurethane material. Instead, "squeeze" the excess solvent from the element.

7. Dip band into light engine oil and squeeze out excess oil.
8. Install band around outer surface of new paper element.
9. Install element in bottom section of air cleaner with either end up.
10. Install air cleaner cover. Do not over-torque nut(s).

## EXHAUST GAS RECIRCULATION (EGR)

### GENERAL

The EGR system (Fig. 6E1-13) is used to lower NO<sub>x</sub> (oxides of nitrogen) emission levels. High combustion temperature causes NO<sub>x</sub> emissions.

The EGR system feeds small amounts of exhaust gas back into the combustion chamber. This burned gas lowers combustion temperatures which lower NO<sub>x</sub> emission levels.

The EGR valve is opened by engine vacuum to let exhaust gas flow into the intake manifold. From there the exhaust gas moves with the air/fuel mixture into the combustion chamber. If too much exhaust gas enters, combustion will not occur. For this reason, very little exhaust gas is allowed to pass through the valve, especially at idle. The EGR valve is usually open under the following conditions:

- Warm engine operation
- Above idle speed

Two types of EGR valves (Fig. 6E1-14) are used:

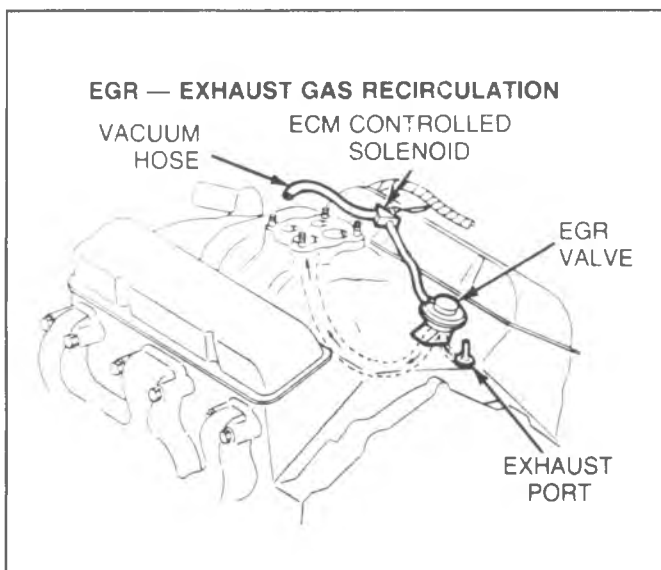

Fig. 6E1-13--EGR System-Typical

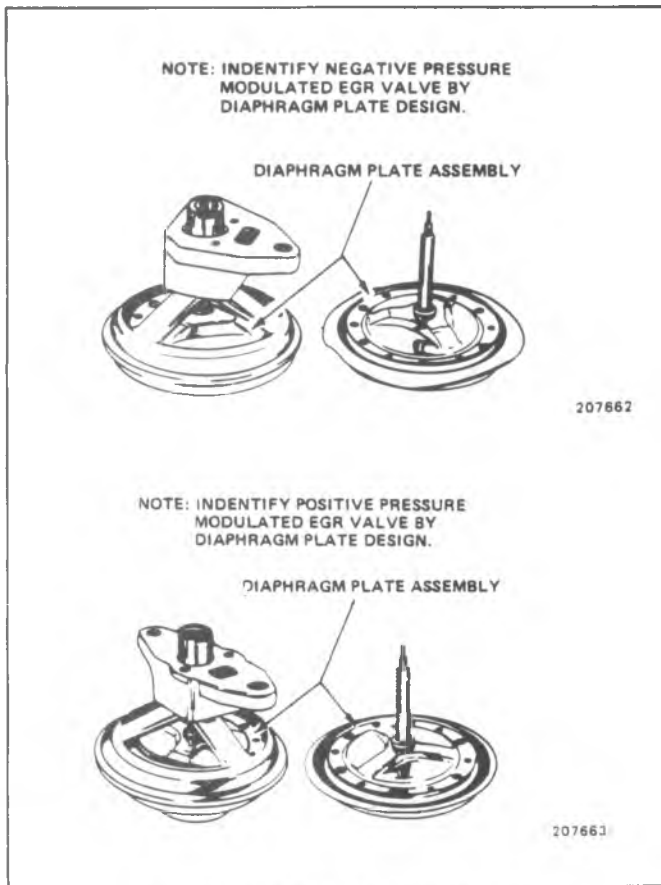

Fig. 6E1-14--EGR Valve Identification

### Positive Backpressure EGR Valve

This valve has an internal vacuum bleed hole that is open when there is low exhaust pressure.

As exhaust backpressure builds, the internal vacuum bleed hole closes allowing engine vacuum to open the EGR valve.

Since the vacuum bleed hole is normally open, this EGR valve cannot be checked with a hand vacuum pump.

### Negative Backpressure EGR Valve

This valve has an internal vacuum bleed hole that is closed with no exhaust backpressure.

Engine vacuum opens the EGR valve. When the intake manifold vacuum combines with negative exhaust backpressure, the vacuum bleed hole opens and the EGR valve closes.

### EGR Bleed

Some engines apply ported vacuum to the EGR valve but decrease vacuum when cold with a bleed solenoid. Some engines decrease the ported vacuum to the EGR valve when the transmission converter clutch is applied.

### Thermal Vacuum Switch

A thermal vacuum switch (TVS) opens a vacuum source when a calibrated temperature is reached. Refer to the number stamped on the base of the switch for calibration temperature.

## RESULTS OF INCORRECT EGR SYSTEM OPERATION

Too much EGR flow tends to weaken combustion, causing the engine to run roughly or stop. With too much EGR flow at idle, cruise, or cold operation, any of the following conditions may happen:

- Engine stops after cold start.
- Engine stops at idle after deceleration.
- Car surges during cruise.
- Rough idle.

If the EGR valve should stay open all of the time, the engine may not run.

Too little or no EGR flow allows combustion temperatures to get too high during acceleration and load conditions. This could cause:

- Spark knock (detonation).
- Engine overheating.
- Emission test failure.

## DIAGNOSIS

Refer to Figure 6E1-15 for diagnosis of exhaust gas recirculation system.

### EGR Valve Functional Check

#### Vacuum Modulated and Negative Backpressure EGR Valves

Two different types of backpressure EGR valves are used. A positive transducer valve and a negative transducer valve. The negative transducer backpressure valve is used on engines with a relatively low backpressure to provide the desired opening point and flow rate.

1. Check hose routing (Refer to Vehicle Emission Control Information Label).
2. Check EGR valve signal tube orifice for obstructions.
3. Hook up vacuum gage between EGR valve and carburetor and check vacuum (engine must be at operating temperature approximately 91°C/195°F). With engine running at approximately 3000 RPM, there should be at least 5" of vacuum.
4. Depress the valve diaphragm.
5. With diaphragm still depressed, hold a finger over source tube and release diaphragm.
6. Check diaphragm and seat for movement. Valve is good if it takes over 20 seconds for the diaphragm to move to the seated position (valve closed).
7. Replace EGR valve if it takes less than 20 seconds to move to the seated position.
8. If EGR Valve is okay, check EGR-TV (if used) for correct operation (See EGR-TV checking procedure) or refer to "EGR Check Hart" in this section.

#### Positive Backpressure EGR Valve

1. Check hose routing (refer to Vehicle Emission Control Information Label).
2. Check EGR valve signal tube orifice for obstructions.
 

**On engines with an EGR-TV, there should be no EGR valve movement below the calibration temperature. If there is, test EGR-TV for proper operation.**
3. Check EGR-TV for correct operation. (See EGR-TV)

checking procedure or refer to "EGR CHECK CHART" in this section).

- a. Remove EGR valve from vehicle.
- b. Apply a constant (not hand pump) external vacuum (34 kPa/10" HG or more) supply to EGR vacuum signal tube.
- c. Valve should not be open. If it does, transducer control valve is stuck closed and EGR valve must be replaced.
- d. With the vacuum supply still applied, direct a stream of air from a low pressure source 103 kPa (15 psi) into the valve exhaust gas intake.
- e. Valve should open completely. If it does not open at all, transducer control valve is stuck open and EGR valve must be replaced.
- f. If EGR valve and transducer control valve are both operating, clean EGR mounting surfaces and reinstall valve.

### EGR-TVS Functional Check-Hot

The EGR Thermal Vacuum Switch (TVS) opens as coolant temperature increases, permitting the ported vacuum signal to reach the EGR valve. Check as follows:

1. Remove EGR valve vacuum hose at EGR valve and connect hose to a vacuum gage.
2. Start engine. With transmission selector lever in Neutral or Park, open throttle partially. (Do not overspeed engine) as throttle is open, the vacuum gage should respond with an increase in vacuum reading.
3. If operation is satisfactory, remove gage and reconnect hose to EGR valve.  
If gage does not respond to throttle opening, proceed to Step 4.
4. Remove Carb-to-switch hose from switch and connect hose to vacuum gage. Repeat Step 2.
5. If vacuum gage responds to throttle opening, then switch is defective. Remove switch and replace with new part.  
If gage does not respond to throttle opening, then check for plugged hose or defective carburetor.

### EGR-TVS Functional Check-Cold

This check can be used to diagnosis a stall after cold start or poor driveability immediately after cold start.

The EGR thermal vacuum switch (TVS) should be closed below a coolant temperature of 85°F (29°C) thereby blocking the ported vacuum signal from reaching the EGR valve below that temperature. Check as follows:

1. Drain coolant to below level of switch.
2. Disconnect vacuum lines and remove switch.
3. Inspect switch to make sure it is in good condition.
4. Connect a vacuum hose to lower nipped of switch, marked "C" or "CARB". Connect a vacuum gage to upper nipple, marked "E" or "EGR".
5. Place switch in water at 75°F (24°C) and submerge completely for 2 minutes while agitating water thoroughly.

6. Apply 12 in. hg. (-41 kPa) vacuum to hose on lower nipple of switch. Under this condition, the switch should be closed.

**NOTICE:** Leaks of up to 2 in. hg. (-7 kPa) of vacuum in 2 minutes is allowable and does not mean a defective switch.

7. If operation is satisfactory, reinstall switch. If switch is defective, replace with a new part.
8. Replace coolant and check level.

## ON-VEHICLE SERVICE

### EGR Valve Replacement (Fig. 6E1-16)

1. Disconnect EGR valve vacuum hose at valve.
2. Remove bolts or nuts holding EGR valve on manifold or adapter.
3. Remove EGR valve from manifold or adapter.
4. Clean EGR mounting surfaces.
5. Install replacement EGR valve on intake manifold or adapter using new gasket(s). Install spacer (if used). Tighten bolts to 14 N·m (18 ft. lbs.).
6. Connect vacuum hose to valve.

### EGR System - Inspection and Cleaning

The following procedure is to be used for the inspection and cleaning of the EGR valve and passages.

#### EGR Passage Cleaning

If inspection of EGR passages in the inlet manifold or adapter indicates excessive build-up of deposits, the passages should be cleaned. Care should be taken to ensure that all loose particles are completely removed to prevent them from clogging the EGR valve or from being ingested into the engine.

Do not wash valve assembly in solvents or degreaser - permanent damage to valve diaphragm may result. Also, sand blasting of the valve is not recommended since this can affect the operation of the valve.

1. With a wire wheel, buff the exhaust deposits from the mounting surface and around the valve.
2. Look for exhaust deposits in the valve outlet. Remove deposit build-up with a screwdriver.
3. Clean mounting surfaces of intake manifold and valve assembly.

### EGR-TVS

#### Replacement

1. Drain engine coolant.
2. Disconnect vacuum lines from the thermal vacuum switch.
3. Remove switch.
4. Apply an approved sealer to threaded portion of switch.
5. Install switch and torque to 20 N·m (15 lbs. ft.).
6. Rotate switch head as required to align for proper hose routing.
7. Install vacuum hoses to switch.
8. Replace engine coolant and check level.

| CONDITION   | POSSIBLE CAUSE   | CORRECTION  |
|---|--|---|
| Engine idles abnormally rough and/or stalls.  | EGR valve vacuum hoses misrouted.<br><br>Leaking EGR valve.<br><br>EGR valve gasket failed or loose EGR attaching bolts.<br><br>EGR-TVS.<br>Improper vacuum to EGR valve at idle.                | Check EGR valve vacuum hose routing. Correct as required.<br><br>Check EGR valve for correct operation.<br>Check EGR attaching bolts for tightness. Tighten as required. If not loose, remove EGR valve and inspect gasket. Replace as required.<br>Perform EGR-TVS functional check. Check vacuum from carburetor EGR port with engine at stabilized operating temperature and at curb idle speed. (See checking EGR valve.) |
| Engine runs rough on light throttle acceleration and has poor part load performance.  | EGR valve vacuum hose misrouted.<br><br>Check for loose valve.<br><br>Failed EGR-TVS (TVS open below 130°F.)<br><br>Sticky or binding EGR valve.<br>Wrong or no EGR gasket(s) and/or Spacer.     | Check EGR valve vacuum hose routing. Correct as required.<br><br>Torque valve.<br><br>Same as listing in "Engine Idles Abnormally Rough and/or Stalls" condition.<br>Clean EGR passage deposits. Perform EGR System check.<br>Install new gasket(s), install spacer (if used), torque attaching parts.  |
| Engine stalls on decelerations.   | Transducer control valve blocked or air flow restricted.<br><br>Restriction in EGR vacuum line or vacuum signal tube.<br><br>Sticking or binding EGR valve.                                      | Check transducer control valve operation (See Checking Back Pressure EGR Valve).<br><br>Check EGR vacuum lines for kinks, bends, etc. Remove or replace hoses as required. (See Checking EGR Valve).<br>Check EGR valve for excessive deposits causing sticky or binding operation.<br>Perform EGR System Check.  |
| Part throttle engine detonation.<br><br>(NOTICE: Non-Functioning EGR valve could contribute to part throttle detonation. Detonation can also be caused by several other engine variables. Perform ignition and carburetor related diagnosis.) | Transducer control valve blocked or air flow restricted.<br><br>Insufficient exhaust gas recirculation flow during part throttle accelerations.<br><br>Control valve blocked or flow restricted. | Check internal control valve operation (See Checking EGR Valve).<br>Check EGR valve hose routing. Check EGR valve operation. Repair or replace as required. Check EGR-TVS as listed in "Engine Idles Abnormally Rough and/or Stalls" section. Replace valve as required. Check EGR passages and valve for excessive deposit. Clean as required.<br>Check EGR per service procedure.   |
| Engine starts but immediately stalls when cold.<br>(NOTICE: Stalls after start can also be caused by carburetor problems.)  | EGR valve hoses misrouted.<br><br>EGR-TVS system malfunctioning when engine is cold.   | Check EGR valve hose routings.<br><br>Perform EGR-TVS functional check.   |

Fig. 6E1-15--EGR Diagnosis

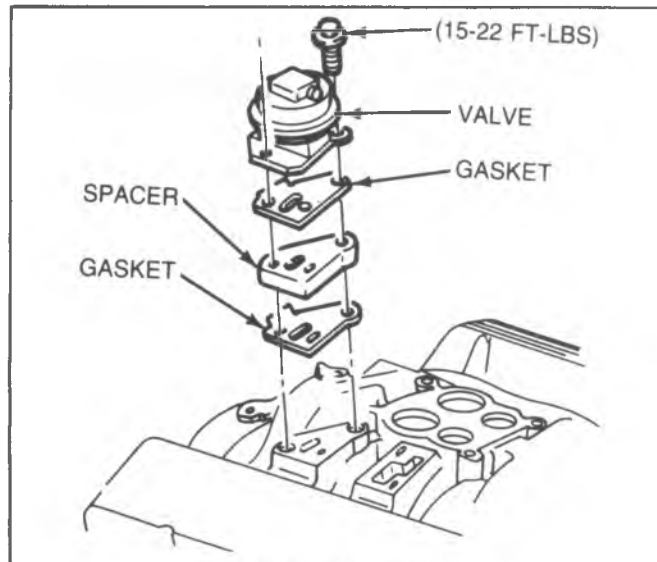

Fig. 6E1-16--EGR Mounting

## EARLY FUEL EVAPORATION SYSTEM

driveability. It also reduces the length of time carburetor choking is required, making reduction in exhaust emission levels possible.

The EFE System (except 4.8L) uses a valve and vacuum actuator (Fig. 6E1-17) which increases the exhaust gas flow under the intake manifold during cold engine operation. The valve is vacuum operated and is controlled by a Thermal Vacuum Switch (TVS).

The 4.8L engine uses a manifold heat valve which is operated by a thermal spring that responds to exhaust manifold temperature.

## DIAGNOSIS

### General

The operation of the EFE valve is to be checked at regular maintenance intervals (refer to Section 0B for maintenance interval information). Before performing the following EFE valve functional test, the vehicle should be allowed to cool down so that the engine temperature is below 40°C (105°F).

### Vacuum Servo Type

#### Functional Check

1. Locate EFE valve and note position of the actuator arm. On some V-8 engines, the EFE valve actuator arm is protected with a two piece metal cover. When service of the EFE valve is required, the cover must be removed for access and replaced when service is completed.
2. Observe EFE valve when engine is started. Valve should close when engine is started cold. The actuator link will be pulled into the diaphragm housing.
3. If valve does not close, stop engine and remove hose from EFE valve and apply an external vacuum source (hand pump) in excess of 34 kPa (10" HG). Valve should close and remain closed for a minimum of 20 seconds without applying additional vacuum. Replace EFE valve if leak-down time is less than 20 seconds.

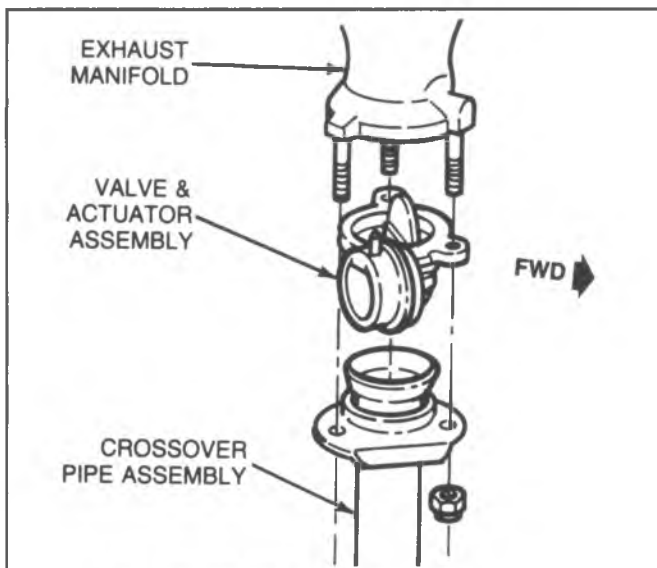
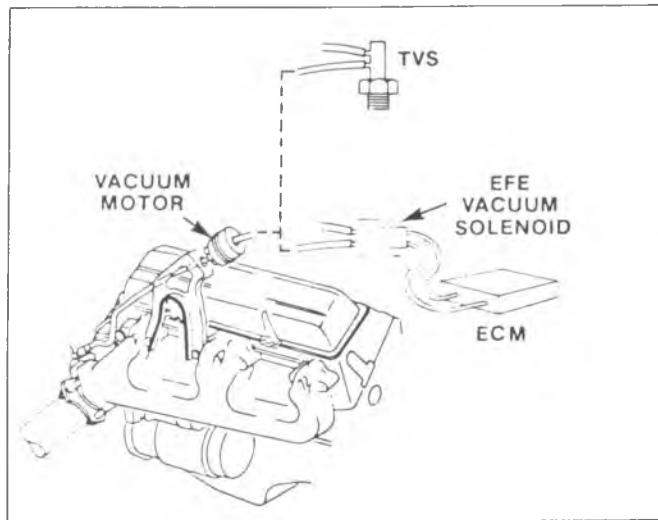
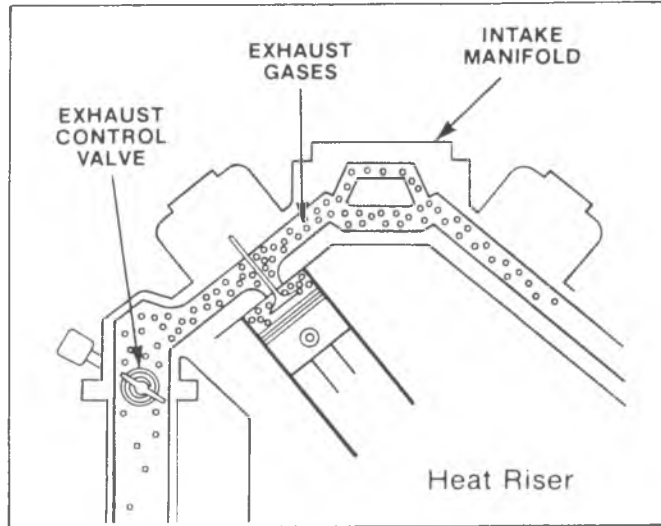

Fig. 6E1-17--EFE System--Typical

## GENERAL

The EFE system provides a source of rapid heat to the engine induction system during cold driveaway. Rapid heating is desirable because it provides quick fuel evaporation and more uniform fuel distribution to aid cold

## EARLY FUEL EVAPORATION



- a. If valve does not close, the valve could be seized. Lubricate with manifold heat valve lubricant, Part Number 1050422, or equivalent or replace as required.
  - b. If valve does not close when vacuum is applied and is not seized (Step a), the vacuum diaphragm is defective. Replace EFE valve and proceed with functional check.
  - c. If valve closes, the problem is not the EFE valve. Check for loose, kinked, pinched, plugged or cracked vacuum hoses and connections, and repair as required.
4. Warm up engine to normal operating temperature.
  5. Observe EFE valve to see if it has opened. Valve should open.
  6. If valve does not open, remove hose from EFE valve to see if it will open. If valve opens, there is no air bleed for the valve diaphragm, the TVS is stuck in the cold mode or the engine is not reaching proper operating coolant temperature. Check thermostat. Replace TVS as determined in Step 3C.

## ON-VEHICLE SERVICE

### EFE Actuator Assembly

The EFE actuator assembly is located on a bracket attached to right exhaust manifold or mounted directly to the right or left exhaust manifold. Actuators which are remotely located on bracket are connected to the heat valve by a rod.

#### Replacement

1. Disconnect vacuum hose from actuator.
2. Remove fasteners holding actuator to manifold bracket.
3. If used, disconnect rod from actuator and remove.
4. Remove actuator.
5. Install actuator and rod (if used) reversing Steps 1 through 4. Tighten nuts to 3 N·m (25 in. lbs.).

### EFE Exhaust Heat Valve - V8

#### Replacement

1. Remove crossover exhaust pipe.
2. Disconnect rod from valve.

3. Remove valve.
4. Install valve and connect rod.
5. Install crossover exhaust pipe.

### EFE Exhaust Heat Valve -4.1L

#### Replacement

1. Remove 2 nuts attaching actuator bracket-to-valve and exhaust manifold.
2. Remove bracket and disconnect rod from valve.
3. Remove 2 additional nuts from valve and remove valve.
4. Install valve reversing Steps 1 through 3.

### Manifold Heat Valve-4.8L

#### Replacement

1. Remove exhaust pipe to manifold nuts and lower exhaust pipe.
2. Remove heat valve and packings.
3. Reverse above steps to install.

### Thermal Vacuum Switch (TVS)

#### Replacement-Coolant Temperature-V8

1. Drain coolant below level of engine coolant outlet housing.
2. Disconnect hoses at TVS ports.
3. Remove TVS.
4. Apply a soft setting sealant uniformly on replacement TVS male threads. No sealant should be applied to sensor end of TVS.
5. Install TVS, tighten to 120 pound inches (14 N·m) (10 ft. lbs.) and then hand torque clockwise as required to align TVS to accommodate hoses.
6. Connect hoses to TVS ports.
7. Add coolant as required.

#### Replacement - Oil Temperature-L6

#### Replacement

1. Disconnect hoses at TVS ports.
2. Remove TVS switch.
3. Install TVS switch.
4. Connect hoses to TVS ports.

## COMPUTER COMMAND CONTROL SYSTEM

### CALIFORNIA ONLY

#### GENERAL

The Computer Command Control System (the "System") in California is an electronically controlled emission system that controls:

- Fuel delivery
- Air Injector Reactor (AIR)
- Evaporative Emission Control (EEC)
- Electronic Spark Timing (EST)
- Torque Converter Clutch (TCC)

This system monitors various engine/vehicle operating conditions and using this information can control engine

related systems (Figs. 6E1-19 and 6E1-20). The "SYSTEM" is thereby making constant adjustments to maintain good vehicle performance under all normal driving conditions while allowing the catalytic converter to effectively control exhaust emissions.

The "System" has a built-in diagnostic system that recognizes and identifies possible operational problems and alerts the driver through a "CHECK ENGINE" light in the instrument panel. The light will remain "ON" until the problem is corrected. This same light is used, with the built-in diagnostic system, to aid the technician in



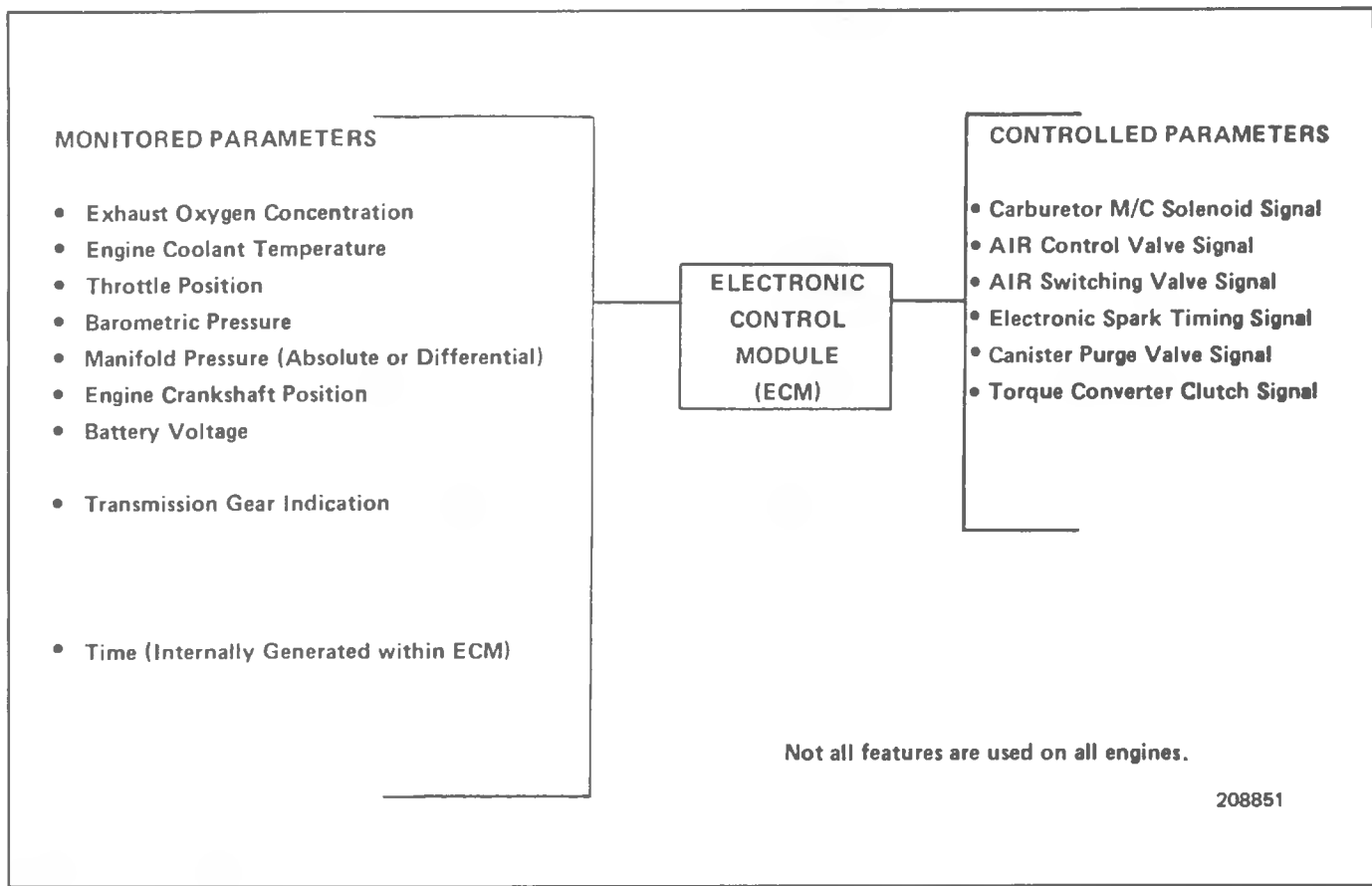

Fig. 6E1-19--System Parameters

locating and repairing the problem by flashing a stored code or codes which identifies the possible problem areas.

The "System" also has built-in backup systems that in most cases of an operation problem will allow continued operation of the vehicle in a near normal manner until repairs can be made.

### Electronic Control Module (ECM)

The Electronic Control Module (ECM), located in the passenger compartment, is the control center of the Computer Command Control System. The ECM constantly monitors the input information, processes this information and generates output commands to the various systems that affect vehicle performance (Fig. 6E1-19).

The ability of the ECM to recognize and adjust for vehicle variations (engine transmission, vehicle weight, axle ratio, etc.) is provided by a removable Calibration Unit (PROM) that is programmed to tailor the ECM for the particular vehicle. There are specific ECM/PROM combinations for each specific vehicle and they are not interchangeable (Fig. 6E1-21). The ECM housing should be insulated from the body to prevent damaging the ECM if a bad ground between the engine and body should occur.

The ECM also performs the diagnostic function of the system, recognizing operational problems, alerting the driver through the "CHECK ENGINE" light and storing a code or codes which identify the problem areas to aid the technician in making repairs.

### Coolant Sensor (Fig. 6E1-22)

The coolant sensor is mounted in the engine coolant stream. It has high resistance when the coolant is cold and

low resistance when the coolant is warm. The coolant sensor supplies coolant temperature information to the ECM which is used to control the following engine systems:

1. Air/fuel ratio control through the M/C Solenoid to provide good cold start and driveability.
2. Air Injection Reactor System, EST control and Canister purge.

The coolant sensor also provides a switch point signal for the "HOT ENGINE" light.

### Vacuum Sensor

The Vacuum Sensor, mounted in the engine compartment, measure changes in manifold pressure and provides this information (electrical signal) to the ECM. The pressure changes reflect need for adjustments in air/fuel mixture, spark timing (EST), etc., that are required to maintain good vehicle performance under various driving conditions.

The Vacuum Sensor also is used as a measure of engine load. It produces a low voltage when manifold vacuum is low and a high voltage when manifold vacuum is high. It is also called a differential pressure sensor because it measures the difference between atmospheric and manifold pressure.

### FUEL CONTROL SYSTEM

Refer to the fuel control system in this section for service information relating to ECM control. Diagnosis of the fuel control system is in the Computer Command Control system section.

Refer to Carburetor Sections 6C1 (E4ME) or 6C3 (E2SE) in this manual for adjustments and replacement procedures.

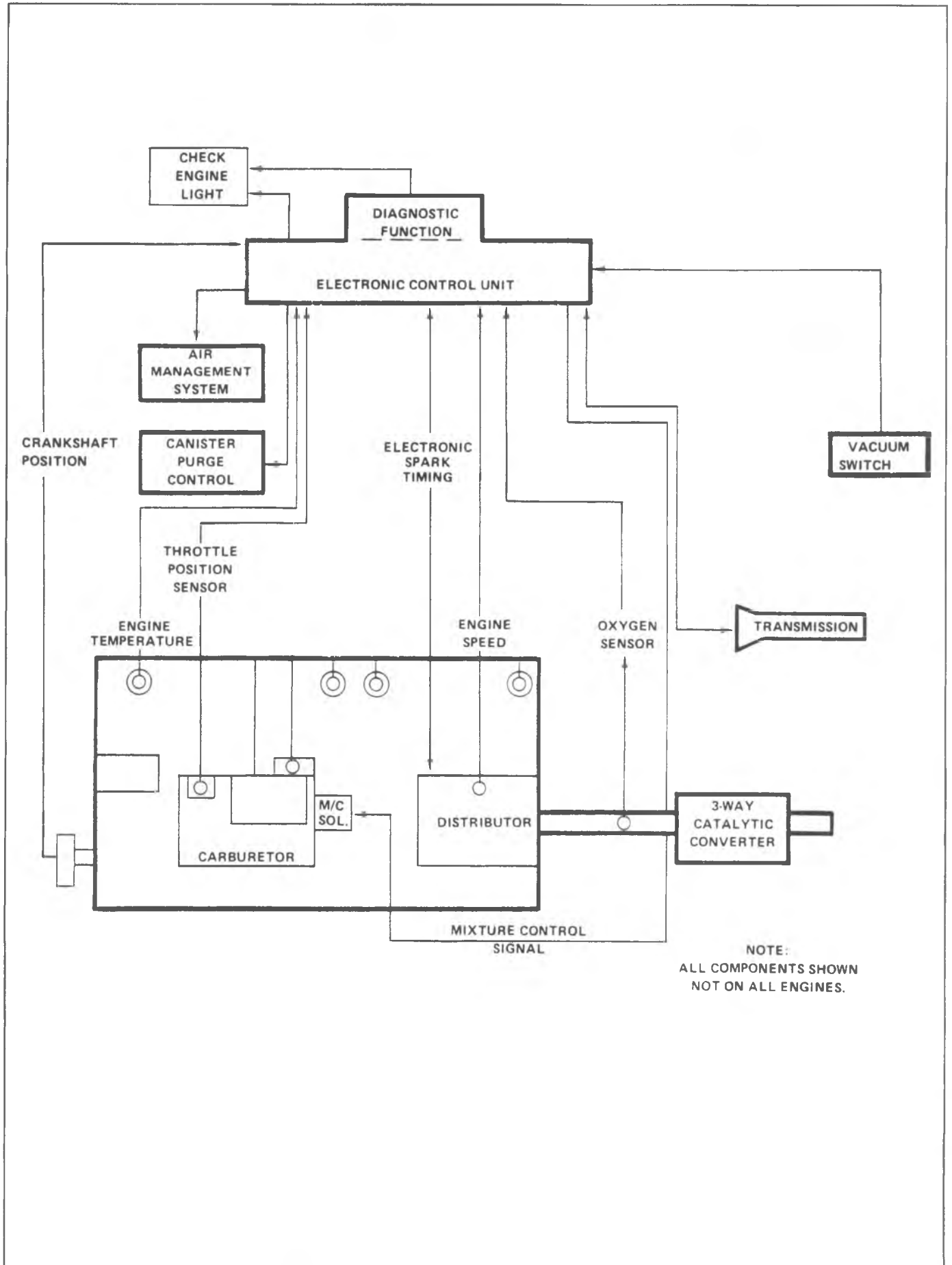

Fig. 6E1-20--Computer Command Control Schematic

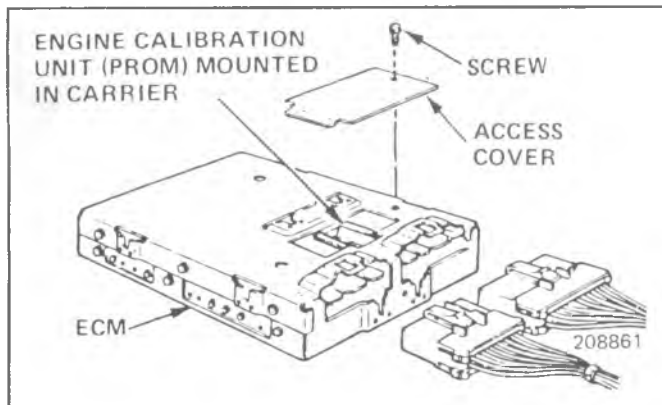

Fig. 6E1-21--ECM/PROM Assembly

### AIR INJECTION REACTOR

Refer to air injection reactor section for service information relating to the ECM control.

### EVAPORATIVE EMISSION CONTROL

Refer to the evaporative emission control section for service information relating to the ECM control on a V8 engine.

### ELECTRONIC SPARK TIMING

Refer to EST section and Section 6D for service information relating to ECM control.

### TORQUE CONVERTER CLUTCH

Refer to TCC Section and Section 7A for service information relating to ECM Control.

## DIAGNOSTIC PROCEDURES

A built-in, self-diagnostic system catches the problems most likely to occur. The diagnostic system lights a "CHECK ENGINE" light in the instrument panel when a problem is detected. By grounding a trouble code "TEST" terminal under the dash, the "CHECK ENGINE" light will flash a trouble code or codes indicating the problem areas.

As a bulb and system check, the "CHECK ENGINE" light will come "ON" with the ignition switch "ON" and the engine not running. If the "TEST" terminal is then grounded, the light will flash a code "12" which indicates the self-diagnostic system is working. A code "12" consists of **one flash, followed by a short pause, then two flashes in quick succession**. After a longer pause, the code will repeat two(2) more times.

When the engine is started, the "CHECK ENGINE" light will remain "ON" momentarily and then turn off. If the "CHECK ENGINE" light remains on, the self-diagnostic system has detected a problem. Refer to Trouble Code Identification for reason a code set. If the Trouble Code "TEST" terminal is then grounded, (Fig. 6E1-23), the stored trouble code will flash three(3) times. If more than one problem has been detected, each trouble code will flash three(3) time. Trouble codes will flash in numeric order (lowest number code first). The trouble code series will repeat as long as the "TEST" terminal is grounded.

A trouble code indicates a problem in a given circuit (Trouble Code "14") for example, indicates a problem in the Coolant Sensor Circuit, this includes the coolant sensor,

connector, harness, and ECM). The procedure for finding where the problem is can be found in Diagnosis Chart #14. Similar charts are provided for each code.

Since the self-diagnostics do not detect all possible faults, the absence of a code does not mean there are no problems in the "System". To determine if there is a "System" problem, a System Performance Check is necessary. This check is made when the "CHECK ENGINE" light and self-diagnostic system do not indicate a problem, but the "System" is suspected and no other reason can be found for the complaint.

### TROUBLE CODE "TEST" LEAD

The trouble code "TEST" lead terminal (Figs. 6E1-23 and 24) is mounted in a 12 terminal connector located under the left side of the dash. This same connector is used at assembly to evaluate the system and is known as the Assembly Line Diagnostic Link (ALDL) or Assembly Line Communication Link (ALCL). With the ignition "ON", jumper the "test" terminal-to-ground terminal (Fig. 6E1-24). Grounding this terminal signals the ECM to flash any trouble codes stored in memory.

If the "TEST" lead terminal is grounded with the ignition "on" and the engine stopped, the ECM will:

1. Flash trouble code 12 and any other stored codes.
2. Send a 30" dwell signal to the M/C solenoid.
3. Energize all ECM controlled solenoids.

If the "TEST" lead terminal is grounded with the engine running, the ECM will:

1. Not set any trouble codes (if none are stored).
2. Take out the open loop timer, start-up enrichment, and blended enrichment.
3. Send a 30" dwell to the M/C solenoid whenever the system is in open loop if it is not in the enrichment mode.
4. Cause EST to be set at a fixed spark advance.

### TROUBLE CODE MEMORY AND TROUBLE CODE CLEARING

When a fault develops in the system, the "CHECK ENGINE" light will come on and a trouble code will be set

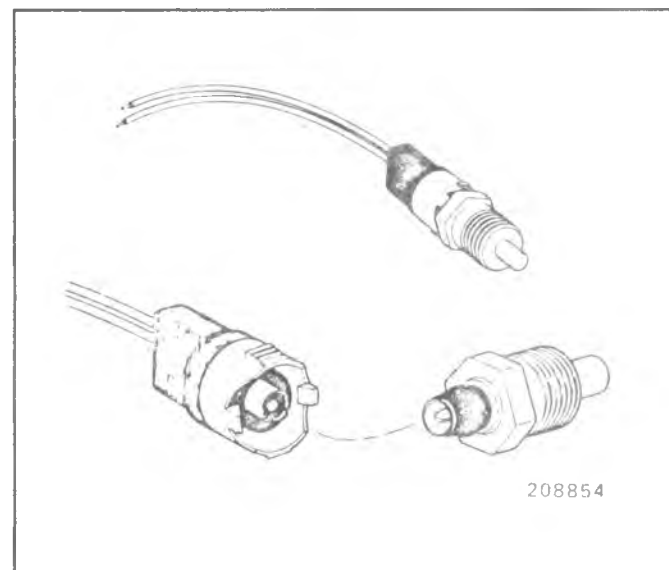

Fig. 6E1-22--Coolant Sensor

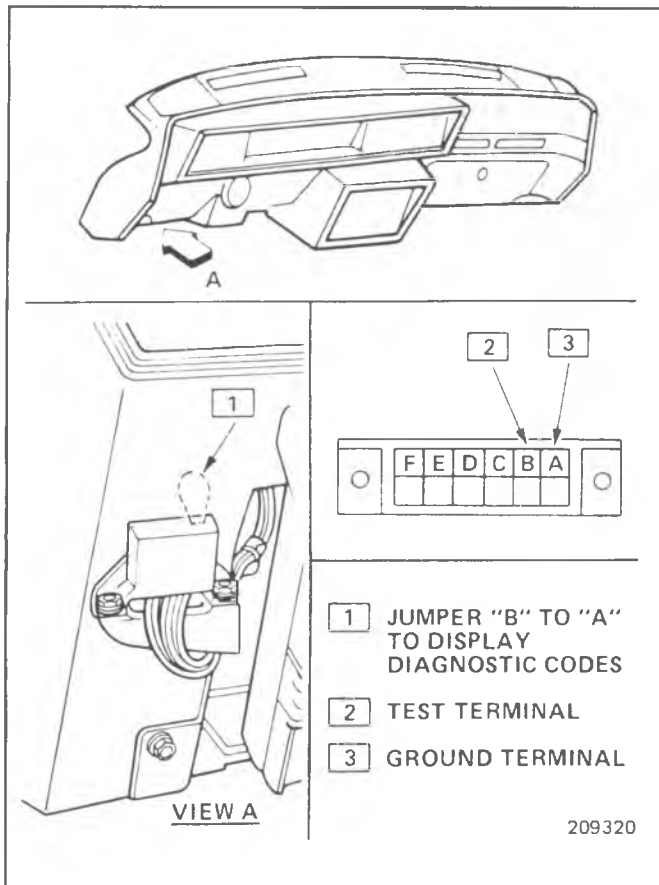

Fig. 6E1-23--Under Dash Connector

in the ECM memory. If the fault is intermittent, the "CHECK ENGINE" light will go out after 10 seconds when the fault goes away. However, the trouble code will be retained in the ECM memory until the battery voltage to ECM terminal "R" is removed. Removing battery voltage to terminal "R" for 10 seconds will clear all stored trouble codes. To do this, remove "ECM" fuse in the upper right corner of the fuse panel.

If a trouble code can be obtained when the "CHECK ENGINE" light is "OFF" with the engine running, the trouble code must be evaluated. A determination must be made to see if the fault is intermittent or if the engine must be at certain operating conditions to turn the "CHECK ENGINE" light "ON".

Faults indicated by certain trouble codes, such as 13, 24, 44 and 45, require engine operation under certain conditions such as part throttle, for a period of time before the "CHECK ENGINE" light will come on and store a trouble code.

The fault indicated by trouble code 15 takes five minutes of engine operation before it will display. The diagnostic charts for trouble codes 13, 15, 41, 44, 45 and 55 should be used if any of these trouble codes can be obtained.

If any other trouble code is stored, but the "CHECK ENGINE" light was not on, the diagnostic charts for these codes cannot be used, because the system is operating properly at the time. A physical inspection of the circuit indicated by the trouble code should be made. It should be checked for poor connectors, frayed wires, etc., and the "System Performance Check" should be made.

## PROM REPLACEMENT

If the diagnostic procedures call for the ECM to be replaced, the calibration unit (PROM) should be checked first to see if it is the correct PROM. If it is correct, the PROM should be removed from the defective ECM and installed in the new service ECM. **THE SERVICE ECM WILL NOT CONTAIN A PROM.** Trouble Code "51" indicates the PROM is installed improperly or has malfunctioned. When CODE "51" is obtained, the PROM installation should be checked for bent pins or pins not fully seated in the socket. If the PROM is installed correctly and Code "51" still shows, it should then be replaced.

## CONNECTOR INSPECTION

All System connections in the engine compartment are environmentally protected. These new connectors protect the terminals from the dirt and moisture present in the engine compartment. This is important since most "System" signals are low voltage and low current.

Before repairing or replacing any "System" component (harness, sensor, ECM, etc.) as indicated by the diagnostic charts, you should:

1. Disconnect appropriate connector(s) associated with the suspected defective component(s) and check for improper installation, bent, broken, or dirty terminals or mating tabs. Clean, straighten, or replace as required.
2. Reconnect all connectors previously disconnected.
3. Recheck the "System" to see if the problem has been corrected.

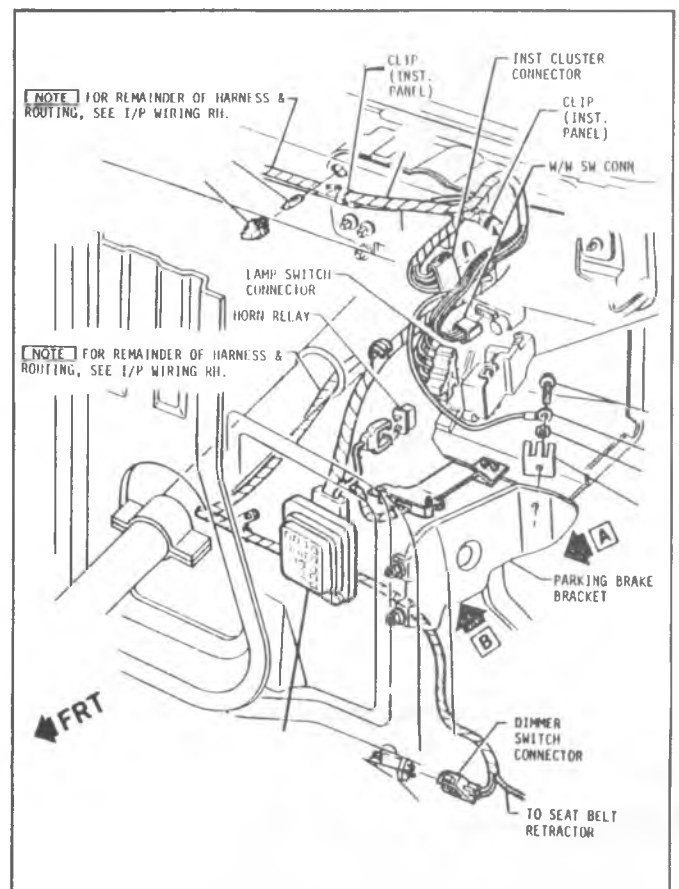

Fig. 6E1-24--Terminal Connector Location

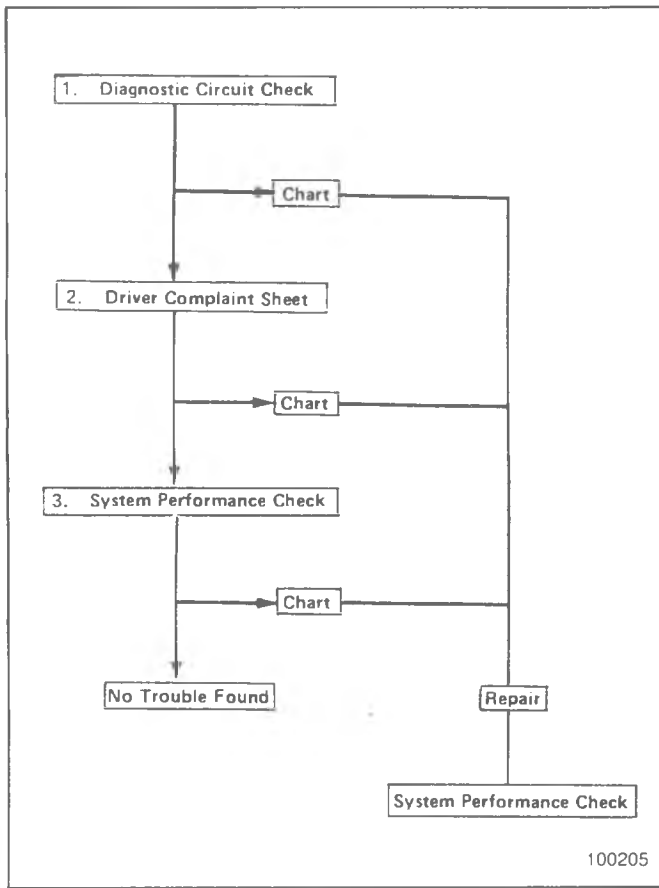

Fig. 6E1-25--Diagnostic Procedure

## DIAGNOSTIC PROCEDURE

The "System" should be considered as a possible source of trouble on engine performance, fuel economy, and exhaust emission complaints only after normal diagnosis, which would apply to a vehicle without the "System" has been made. refer to Section 6 for these diagnostics.

Before diagnosing any "System" controlled by the ECM, always perform the "DIAGNOSTIC CIRCUIT CHECK" (Fig. 6E1-28) first. This will ultimately lead to the "SYSTEM PERFORMANCE CHECK". The "System Performance Check" should always be made after a repair is made to the System.

Although there are many charts connected with System Diagnostics, only a few charts are needed to prove the system is operating properly and, normally only three(3) charts are required to find a problem if one exists.

Figure 6E1-25 summarizes the system diagnosis procedure.

## DIAGNOSTIC CIRCUIT CHECK

The Diagnostic Circuit Check (Fig. 6E1-28) makes sure that the self-diagnostic system works, determines that the trouble codes will display and guides diagnosis to other problems areas.

## SYSTEM PERFORMANCE CHECK

The "System Performance Check" (Fig. 6E1-30) verifies the "System" is functioning correctly. Some special considerations to keep in mind while making the "System Performance Check" are:

### Blocking Drive Wheels

The vehicle drive wheels should always be blocked while checking the system.

## TOOLS AND EQUIPMENT

The Computer Command Control system requires the following tools and equipment (Fig. 6E1-26) to properly diagnose a complete system.

### 1. System Performance Checking

- Tachometer-Either a crankshaft harmonic balance revolution pickup type or electronic coil trigger signal pickup type tachometers can be used for diagnosis.
- Dwellmeter - Used to indicate the performance conditions of the M/C solenoid circuit. Connect the positive lead of dwellmeter to the bright green connector in the Computer Command Control wiring harness near the M/C solenoid and the negative lead to ground. Place meter on 6-cylinder scale. The scale on the meter will show the condition of the M/C solenoid circuit. When needle is on 10° scale, this indicates a rich mixture. A lean mixture will read near 54° scale. A varying needle indicates that the system is in closed loop. Although most dwell meters will work, if one causes a change in engine operation when connected to the M/C solenoid "Dwell" lead, it cannot be used.
- Vacuum Gage-to monitor manifold engine vacuum
- Vacuum Pump (J-23738)-to check pressure or vacuum sensors and vacuum operated valves (EGR, Air Management, etc.).

### 2. Circuit Checking

- Voltmeter and Ohmmeter - use digital volt-ohmmeter J-29125-A to measure voltage and ohms for Computer Command Control circuits. A digital voltmeter with 10 megohms impedance must be used because some circuits require accurate low voltage readings.
- Jumper Wires - to by-pass a circuit and to insert between special connectors to permit access to the connector terminals for circuit checking.
- Test light - to check wiring for complete circuit
- Connector Tools - Use tool J-28742 for removal of terminals on Weather Pack connectors.
- Connector Tool - Use tool J-33095 for removal of ECM connector terminal.

### 3. Adjustment and Removal

- Double-D wrench, J-28696-B-used to adjust rich and lean authority on carburetor.
- Idle Mixture Socket, J-29030-B - used to adjust idle mixture screw on carburetor.
- Oxygen Sensor Wrench, J-29533-used to remove and install oxygen sensor.
- External Float Gage J-9789-130 - used to check M/C solenoid plunger travel
- M/C Solenoid Gage, J-33815-used to adjust M/C solenoid plunger.
- Air Bleed Valve Gage, J-33815-2 -used to adjust air bleed valve.

## TROUBLE CODE IDENTIFICATION

The "CHECK ENGINE" light will only be "ON" if the malfunction exists under the conditions listed below. It takes up to five(5) seconds minimum for the light to come

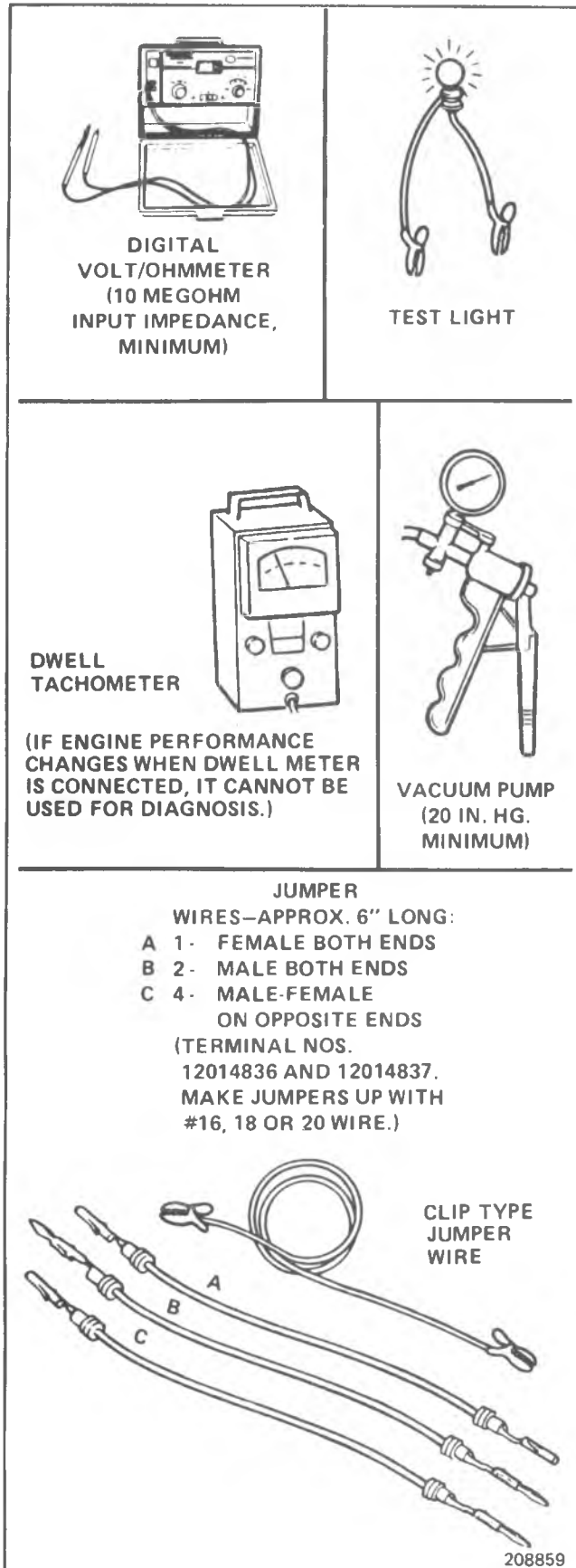

Fig. 6E1-26--Diagnostic Tools

on when a problem occurs. If the malfunction clears-up, the light will go out but the trouble code(s) will be set in the ECM. Code "12" does not store in memory. If the light comes "ON" intermittently, but no code is stored, refer to the "Driver Comments Chart." Any code(s) stored will be cleared if the problem(s) does not reoccur within 50 engine starts.

The trouble codes indicate problems as follows:

- **12** - No distributor reference pulses to the ECM. This code is not stored in memory and will only flash while the fault is present. Normal code with ignition "ON", engine not running (Fig. 6E1-38).
- **13** - Oxygen Sensor Circuit - the engine must run up to five(5) minutes at part throttle, under road load, before this code will set (Fig. 6E1-39).
- **14** - Shorted Coolant Sensor Circuit - The engine must run up to five(5) minutes before this code will set (Fig. 6E1-40).
- **15** - Open Coolant Sensor Circuit - The engine must run up to five(5) minutes before this code will set (Fig. 6E1-46).
- **21** - Throttle Position Sensor Circuit - The engine must run up to 25 seconds, at specified curb idle speed, before this code will set (Fig. 6E1-42).
- **23** - Open or grounded M/C Solenoid Circuit (Fig. 6E1-43).
- **34** - Vacuum Sensor Circuit. The engine must run up to five(5) minutes at specified curb idle speed, before this code will set (Fig. 6E1-44).
- **41** - No distributor reference pulses at specified engine vacuum. This code will store.
- **42** - Electronic Spark Timing (EST) Bypass Circuit grounded or open (Fig. 6E1-46).
- **44** - Lean exhaust indication - The engine must run up to five(5) minutes, in Closed Loop, at part throttle before this code will set (Fig. 6E1-47).
- **45** - Rich exhaust indication - The engine must run up to five(5) minutes, in Closed Loop, at part throttle before this code will set (Fig. 6E1-48).
- **51** - Faulty or improperly installed calibration unit (PROM). It takes up to 30 seconds before this code will set (Fig. 6E1-49).
- **54** - Shorted M/C Solenoid Circuit and/or faulty ECM (Fig. 6E1-49A).
- **55** - Grounded V ref (term. 21), hush voltage on oxygen sensor circuit ECM.

### OTHER SYSTEM DIAGNOSIS

The following diagnostic charts are included in the section to provide diagnosis of the systems that are controlled by the ECM.

- Evaporative Emission Control (Fig. 6E1-80)
- Air Injection Reactor Check (Figs. 6E1-68 and 69)
- EST Diagnosis (Figs. 6E1-83)
- TCC Electrical Diagnosis (Fig. 6E1-84)

### REMOTE LAMP DRIVER (FIG. 6E1-27)

The Remote Lamp Driver controls the "CHECK ENGINE" light. It is a small circuit board which contains several resistors (as well as other components). It is inside a small plastic container taped to the ECM harness near the ECM.

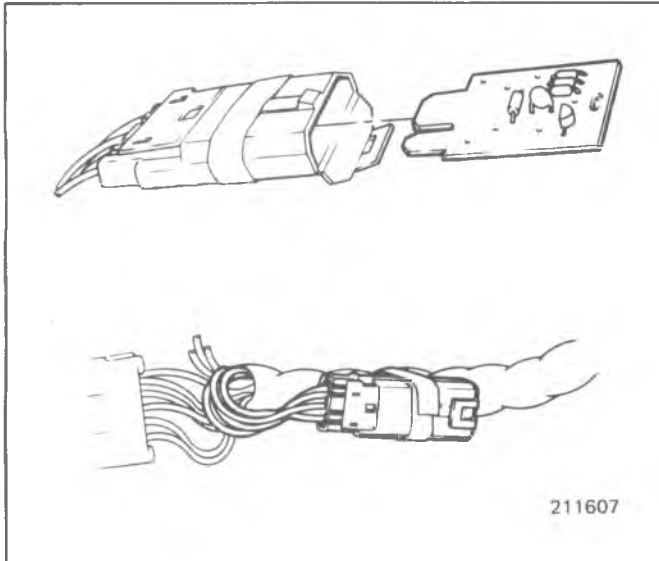

Fig. 6E1-27--Remote Lamp Driver

The main function of the Remote Lamp Driver is to turn on the "CHECK ENGINE" light if: the gage fuse to the ECM blows; the ECM fails; or the ECM loses its power.

Battery voltage is supplied to the "B" terminal of the Remote Lamp Driver, as well as from the gage fuse to the ECM.

A wire connects terminal "C" of the Lamp Driver to the "G" terminal of the ECM. For diagnosis, see Remote Lamp Driver Chart No.5.

## ON-VEHICLE SERVICE

### ELECTRONIC CONTROL MODULE (ECM)

Service of the ECM (Figs. 6E1-51 through 54) should normally consist of only the following operations:

1. PROM Replacement (Figs. 6E1-53 and 54) - ECM's contain an Engine Calibration Unit called a PROM (Programmable Read Only Memory) which provide specific programmed calibration instructions that tailor the ECM to the specific engine/vehicle combination for which it is intended.
  - Code 51 indicates a faulty PROM, bent pins, or incorrect installation. It is possible to install a PROM backwards. If the PROM is installed

backwards and the ignition key turned to "ON", the PROM circuitry will be destroyed, requiring PROM replacement.

- Without a Code "51", a PROM problem is indicated if a 0° dwellmeter reading occurs with the engine running (engine warmed up), or if the engine "HOT" Light comes on at the same time as the "CHECK ENGINE" light.

Before replacing a PROM, check it for proper installation and correct alignment of the locator marks. The PROM's pins should be fully inserted in their sockets when the PROM is plugged into the ECM.

Remove the PROM for inspection, being careful not to bend the pins as you pull the unit out.

If the PROM has been installed correctly, replace the PROM....it has malfunctioned. However, if the PROM has been installed incorrectly, check for bent pins....then put the PROM back into the ECM....and reconnect the ECM. Clear the code(s) and recheck to see if Code "51" returns. If Code "51" returns, the PROM is faulty and must be replaced. Instructions for replacement of the PROM are packaged with each service PROM.

2. ECM Replacement - ECM service consists only of unit replacement if diagnosis indicates replacement to be necessary. Prior to unit replacement, however, connections and terminals should be checked for looseness or improper installation (Fig. 6E1-51).

Service ECMs are supplied without a PROM. The PROM from the faulty ECM should be carefully removed and retained for installation in the service ECM.

### BARO/MAP/VACUUM SENSORS

Vacuum Sensor (Figs. 6E1-55 thru 58) is mounted in the engine compartment. Other than checking for loose hoses and electrical connections, the only service possible is unit replacement if diagnosis shows sensor to be faulty.

### COMPONENT LOCATIONS

Refer to Figures 6E1-67 through 6E1-69 for component locations of the Computer Command Control system.

When troubleshooting the Computer Command Control system, always check the electrical and vacuum connectors which may be the source of a problem before testing or replacing a component.

**DIAGNOSTIC CIRCUIT CHECK  
CKG TRUCK ONLY**

- Always check "PROM" for the correct application and installation before replacing an "ECM".
- Remove terminal(s) from ECM connector for problem circuit involved, clean terminal contact and expand slightly to increase contact pressure and recheck to see if problem is corrected.
- In case of repeat ECM failure, check for a shorted solenoid or replay controlled by the ECM.

**UNDER-DASH CONNECTOR**

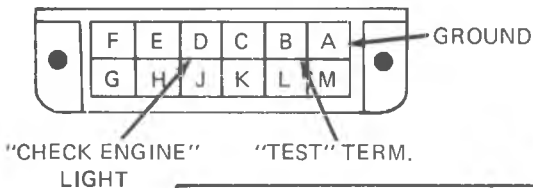

- Key "ON", engine stopped, "test" term. ungrounded.
- Note "Check Engine" light.

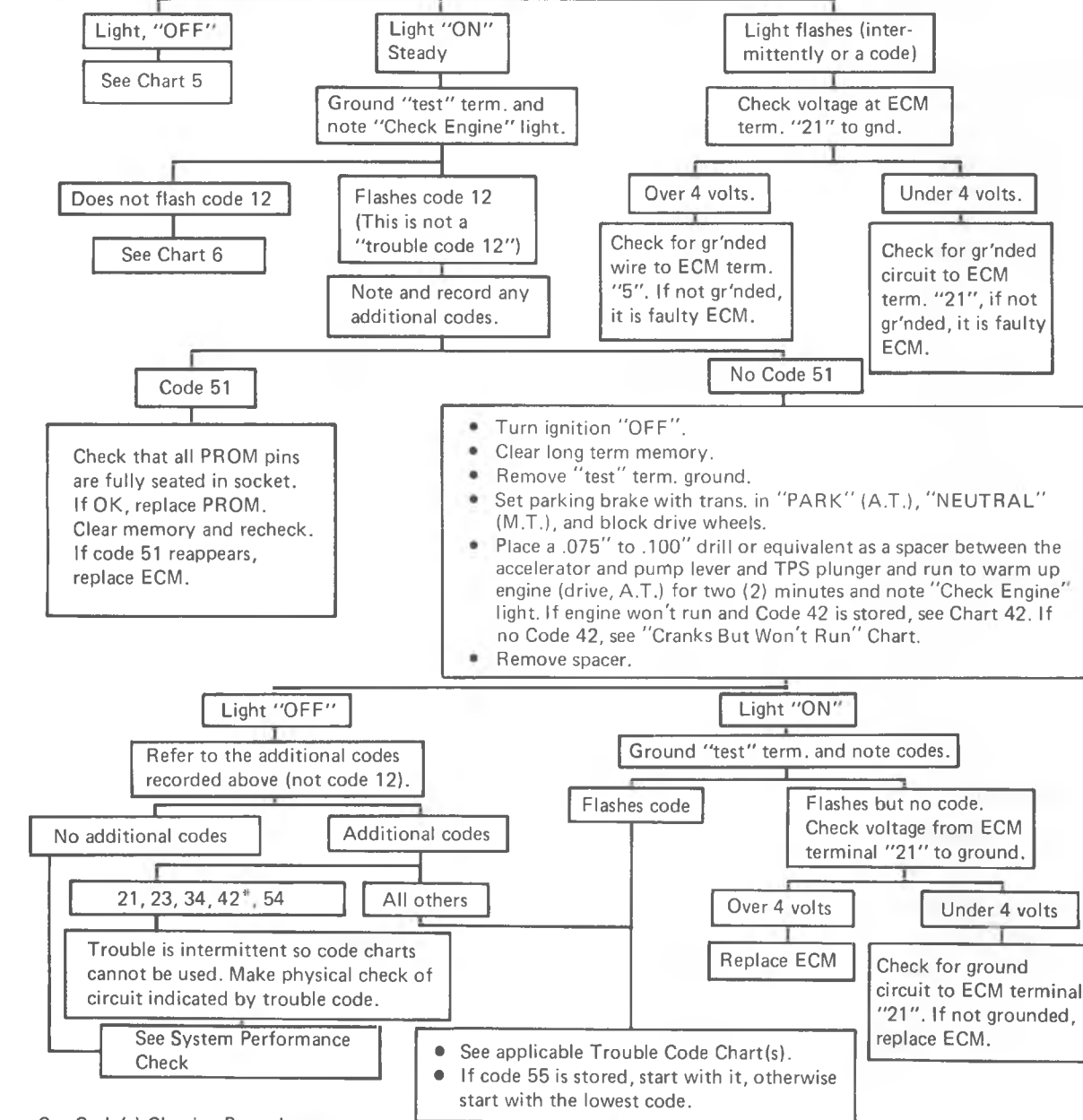

See Code(s) Clearing Procedure.

The System Performance Check should be performed after any repairs to the "System" have been made.

\*It is possible to set a false Code 42 on starting, but the "Check Engine" light will not be "ON." No corrective action is necessary.

Fig. 6E1-28--Diagnostic Circuit Check



1983 CCC  
DRIVER COMMENTS

ENGINE PERFORMANCE PROBLEM (ODOR, SURGE, FUEL ECONOMY . . . )  
EMISSION PROBLEM

IF THE "CHECK ENGINE" LIGHT IS NOT ON, NORMAL CHECKS THAT WOULD BE PERFORMED ON VEHICLE WITHOUT THE SYSTEM SHOULD BE DONE FIRST.

IF GENERATOR OR COOLANT LIGHT IS ON WITH THE "CHECK ENGINE" LIGHT, THEY SHOULD BE DIAGNOSED FIRST.

INSPECT FOR POOR CONNECTIONS AT COOLANT SENSOR, M/C SOLENOID, ETC., AND POOR OR LOOSE VACUUM HOSES AND CONNECTIONS. REPAIR AS NECESSARY.

- Intermittent "Check Engine" light but no trouble code stored.
  - Check for intermittent connection in circuit from:
    - Ignition coil to ground and arcing at spark plug wires or plugs.
    - Bat. to ECM Terms. 'C' and 'R.'
    - ECM Terms. 'A' and 'U' to engine ground.
  - Loss of trouble code (long-term) memory.  
Grounding dwell lead for 10 seconds with "test" lead ungrounded should give Code 23 which should be retained after engine is stopped and ignition turned to "RUN" position.  
If it is not, ECM is defective.
  - EST wires should be kept away from spark plug wires, distributor housing, coil and generator. Wires from ECM Term. 13 to dist. and the shield (if used) around EST wires should be a good ground.
  - Open diode across A/C compressor clutch.
- Stalling, Rough Idle, Dieseling or Improper Idle Speed.  
See Idle Speed Control (ISC) Check.
- Detonation (spark knock)  
Check: ESC System Check, if applicable.  
MAP or Vacuum Sensor output — Chart 7 for MAP sensor or Chart 8 for Vacuum Sensor.  
EGR Check.  
TPS enrichment operation — see Chart 4.  
HEI operation.
- Poor Performance and/or Fuel Economy.  
See EST Performance Check.  
See ESC System Check if applicable.
- Poor Full Throttle Performance  
See Chart 4 if equipped with TPS.
- Intermittent No-start
  - Incorrect pick-up coil or ignition coil. See "Crank, But Won't Run" chart.
  - Intermittent ground connections on ECM.
- ALL OTHER COMPLAINTS  
Make System Performance Check on warm engine (upper radiator hose hot).

The System Performance Check should be performed after any repairs to the system have been made.

H3182Z

104774

**SYSTEM PERFORMANCE CHECK  
(CKG TRUCK ONLY)**

1. Start engine.
2. Ground "test" term. (Must not be grounded before engine is started.)
3. Disconnect purge hose from canister and plug it. On E2SE carburetors, disconnect bowl vent at carburetor.
4. Connect tachometer.
5. Disconnect Mixture Control (M/C) Solenoid and ground M/C Solenoid dwell term.
6. Run engine at 3,000 RPM and, while keeping throttle constant, reconnect M/C Solenoid and note RPM. If car is equipped with an electric cooling fan, it may lower RPM when it engages.
7. Remove ground from M/C Solenoid dwell term. before returning to idle.

Less than 100 RPM drop or RPM increases.

- Check that pink wire is attached to right hand term. of M/C Solenoid Connector, as viewed from harness end (solenoid connected).
- Check evaporator canister for being loaded with fuel and related valves, such as purge and bowl vents for leaks which would cause richness. Also check for fuel in crankcase. If OK, see Carb. On-Vehicle Service, Section 6C.

More than 100 RPM drop.

- Connect dwell meter to M/C sol. dwell term. (6-cyl. scale).
- Set carb. on high step of fast idle cam. and run for one (1) minute or until dwell starts to vary, whichever happens first.
- Return engine to idle. Place a .075" to .100" drill or equivalent as a spacer between the accelerator pump lever and TPS plunger and note dwell. \*

Fixed under 10°

See Chart No. 1

Fixed 10-50°

See Chart No. 2

Fixed over 50°

See Chart No. 3

Varying

Remove TPS spacer  
Check dwell at 3000 RPM

Between 10-50°

Check air management system.

- No trouble found in the "System"
- Clear long term memory. \*\*
- See driver complaints.

Under 10°

Check air switching valve leaking to exhaust ports at 3000 RPM. If not leaking . . .

Over 50°

See Carb. Calibration Procedure—Section 6C, including TPS adjust.

\*Oxygen sensors may cool off at idle and the dwell change from varying to fixed. If this happens, running the engine at fast idle will warm it up again.

\*\*See Code(s) Clearing Procedure.

Fig. 6E1-30--System Performance Check

1983 CCC  
CHART NO. 1  
DWELL FIXED UNDER 10°  
(LEAN EXHAUST INDICATION)

- Ground "Test" terminal.
- With engine at part throttle, choke engine and note dwell (ignore any variation as throttle position is changed).

Dwell increases to over 50°

Dwell did not reach 50°

- Check for air or vacuum leak (including air management system and deceleration valve, if used).
- Check for an exhaust leak.
- Vacuum hose routing.
- Check EGR operation.

- Disconnect Oxygen Sensor.
- Connect digital multimeter J29125-A or equivalent and set on the 20 volt scale, from bat. + to purple wire to ECM (not Oxygen Sensor).\*
- Note dwell, at part throttle.

No leak

Leak

Increases

Under 10°

See Carb. Calibration Procedure—Section 6C

Repair

Check for open from ECM Term. 14 to ground (including ECM connections). If not open, replace oxygen sensor.

- Ignition "On", engine stopped.
- Check voltage from ECM terminals "3" to "7".

Over 3 Volts

Under 3 Volts

Check for open in coolant sensor circuit.

Check for an open from ECM Term. 14 to ground and grounded purple wire to ECM Term. "9". If circuits are OK, check ECM terminal "2" to ground.

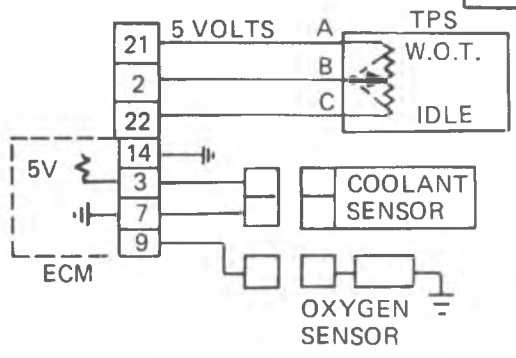

Over 1 volt

Under 1 V

Check for open from ECM term. "22" to TPS term "C".

It is a faulty ECM conn. at term. "14" or ECM

Repair Open

open

not open

Fault is bad ECM connect term. "22" or ECM.

\*Do Not use an ordinary voltmeter or jumper in place of digital voltmeter, because they have too little resistance. A voltage source of 1.0V to 1.7V (such as a flashlight battery) can be connected with the Positive terminal to the purple wire and the negative terminal to ground as a jumper. If the polarity is reversed, it won't work.

Fig. 6E1-31--Chart 1 - Dwell Fixed Under 10°

**1983 CCC  
CHART NO. 2  
DWELL FIXED BETWEEN 10°-50°  
OPEN COOLANT OR OXYGEN SENSOR CIRCUIT  
(CKG TRUCK)**

Check for sticking TPS plunger and adjustment and low coolant.

- Start engine.
- Ground "test" terminal.
- Run engine at part throttle for one minute.
- Return engine to idle.
- Place a 0.75" to .100" drill or equivalent as a spacer between the accelerator pump lever and TPS plunger.
- Disconnect oxygen sensor and ground connector term. on lead to ECM (not sensor). Leave grounded and TPS spaced for rest of checks.
- Note dwell.

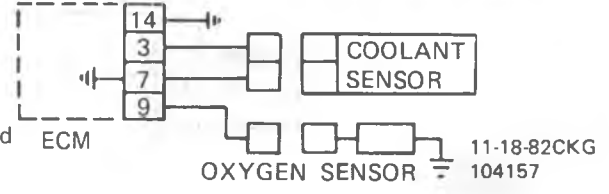
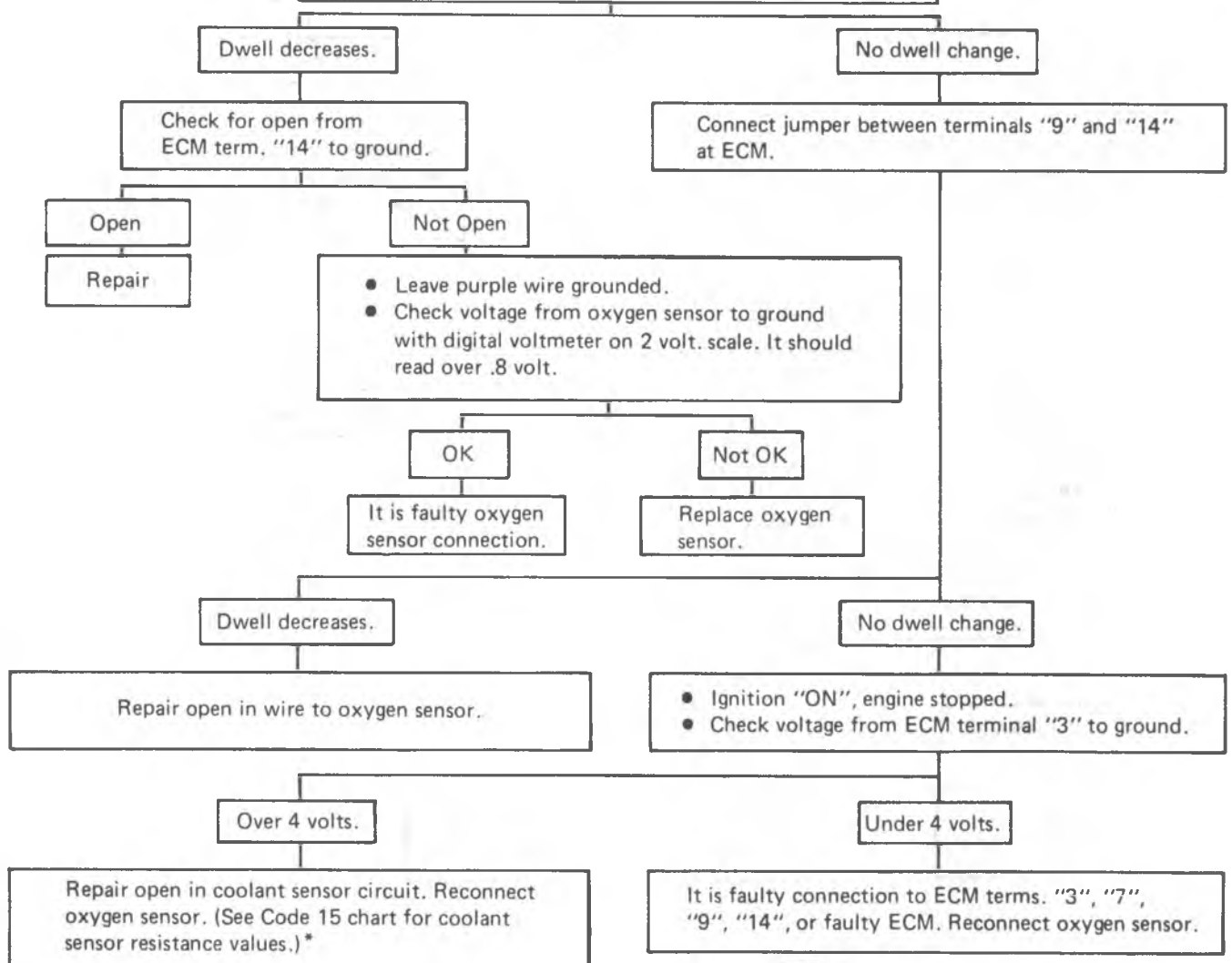

\*Checking coolant sensor resistance may require use of connector and wire assembly No. 12026621 for accessibility.

Fig. 6E1-32--Chart 2 - Dwell Fixed Between 10° - 50°

1983 CCC  
 CHART NO. 3  
 DWELL FIXED OVER 50°  
 RICH EXHAUST INDICATION  
 (CKG TRUCK ONLY)

- Run engine at fast idle for 2 minutes.
- Return to idle.
- Place a .075" to .100" drill or equivalent as a spacer between the accelerator pump lever and TPS plunger.
- Remove large vacuum hose such as PCV but not enough to stall the engine.
- Note dwell, should drop at least 20°

Dwell drops 20°

- Check evap. canister for being loaded with fuel and related valves, such as purge and bowl vent, for leaks which would cause richness, also fuel in crankcase. If OK, see Carb. On-Vehicle Service-Section 6C.

Does not drop 20°

- Disconnect oxygen sensor.
- Ground harness connector terminal on lead to ECM (not oxygen sensor).

Dwell drops to under 10°

- Ign. "ON", engine stopped.
- Remove ground from harness connector and check voltage from that term. to ground with digital voltmeter.

No Dwell Change

Replace ECM

Under .55 Volts

It is faulty oxygen sensor.

Over .55 Volts

Check wire from ECM term. "9" for short to Bat. +. If not shorted, it is faulty ECM.

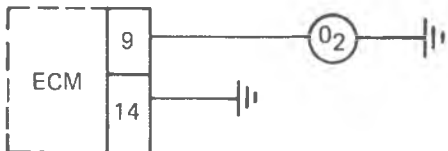

11-18-82CKG  
 104156

Fig. 6E1-33--Chart 3 - Dwell Fixed Over 50°

1983 CCC  
CHART NO. 4

TPS ENRICHMENT CHECK

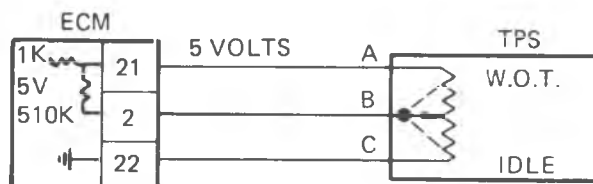
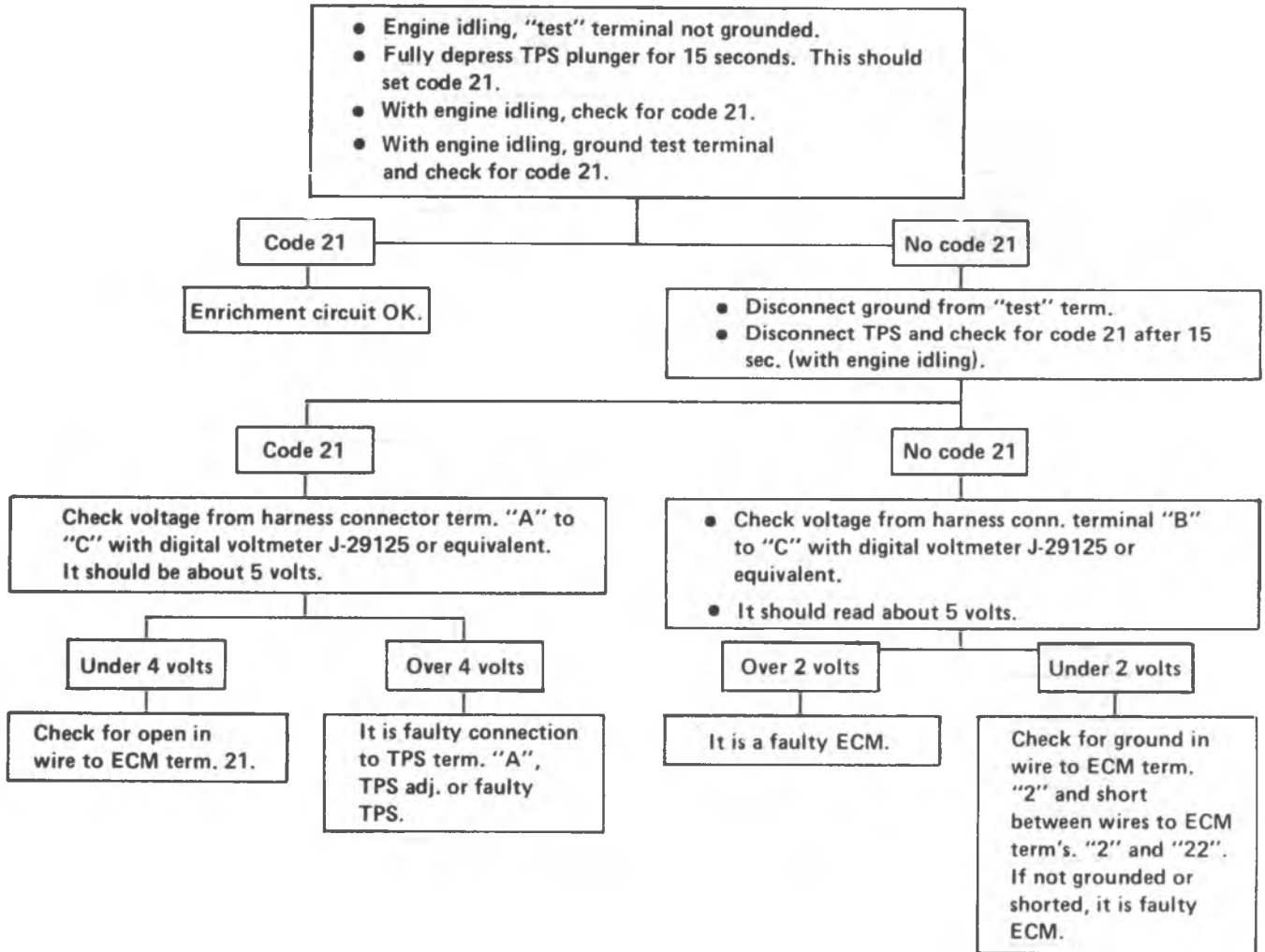
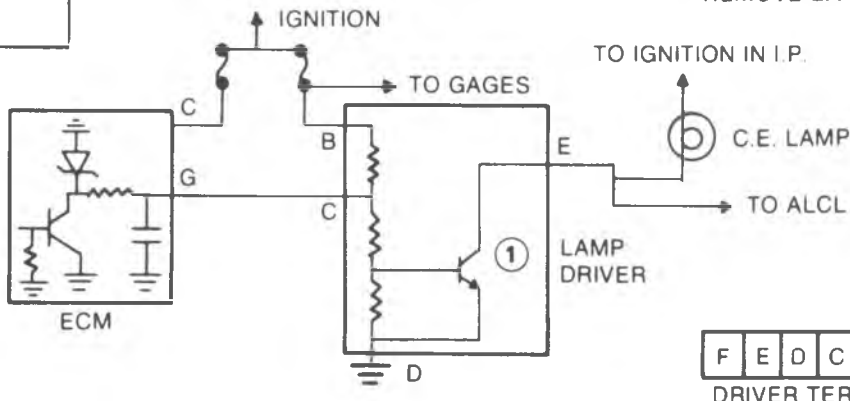
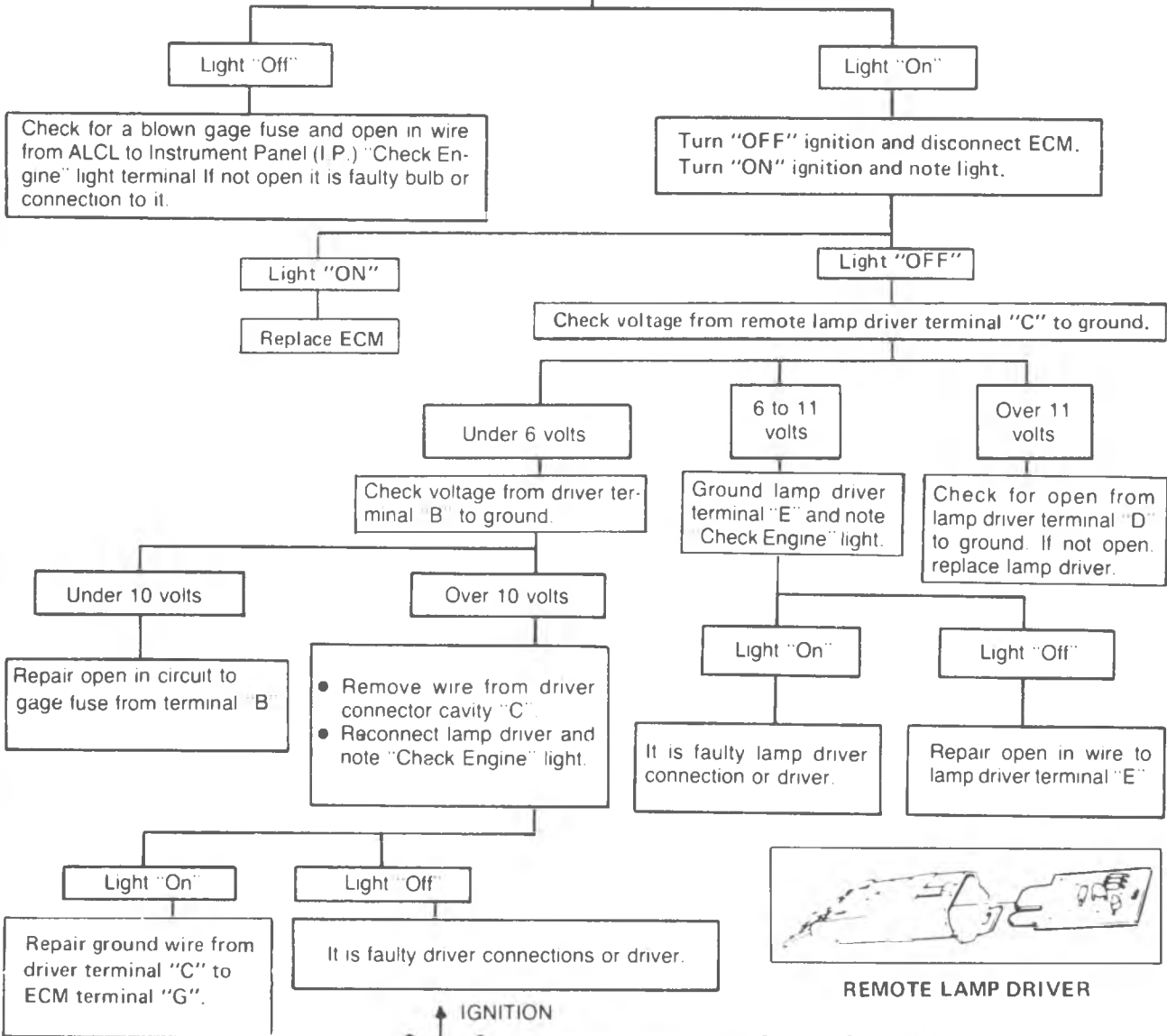

Fig. 6E1-34-Chart 4 - TPS Enrichment Check

1983 CCC  
CHART NO. 5  
"CHECK ENGINE" LIGHT INOPERATIVE

- Ignition "on", engine stopped.
- Momentarily ground "Check Engine" light terminal in ALCL connector (terminal "D") and note "Check Engine" light.



|   |   |   |   |   |   |
|---|---|---|---|---|---|
| F | E | D | C | B | A |
|---|---|---|---|---|---|

DRIVER TERMINAL

H3182Z  
104780

Fig. 6E1-35--Chart 5 - "Check Engine" Light Inoperative

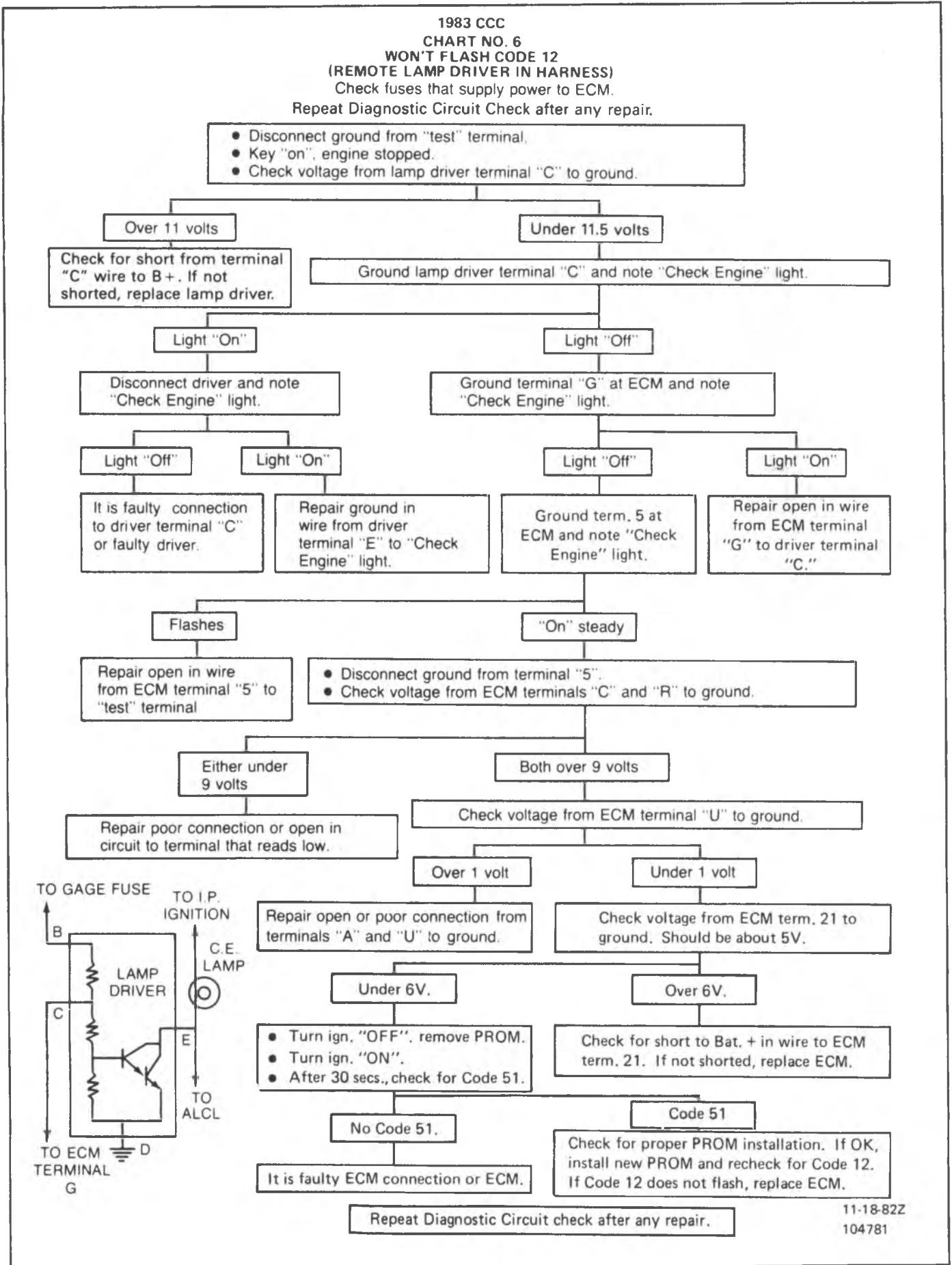
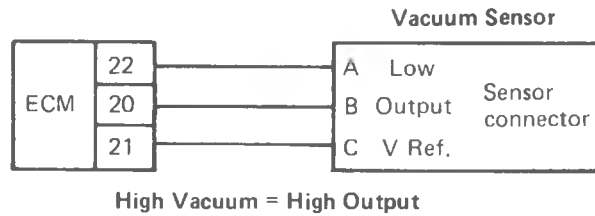
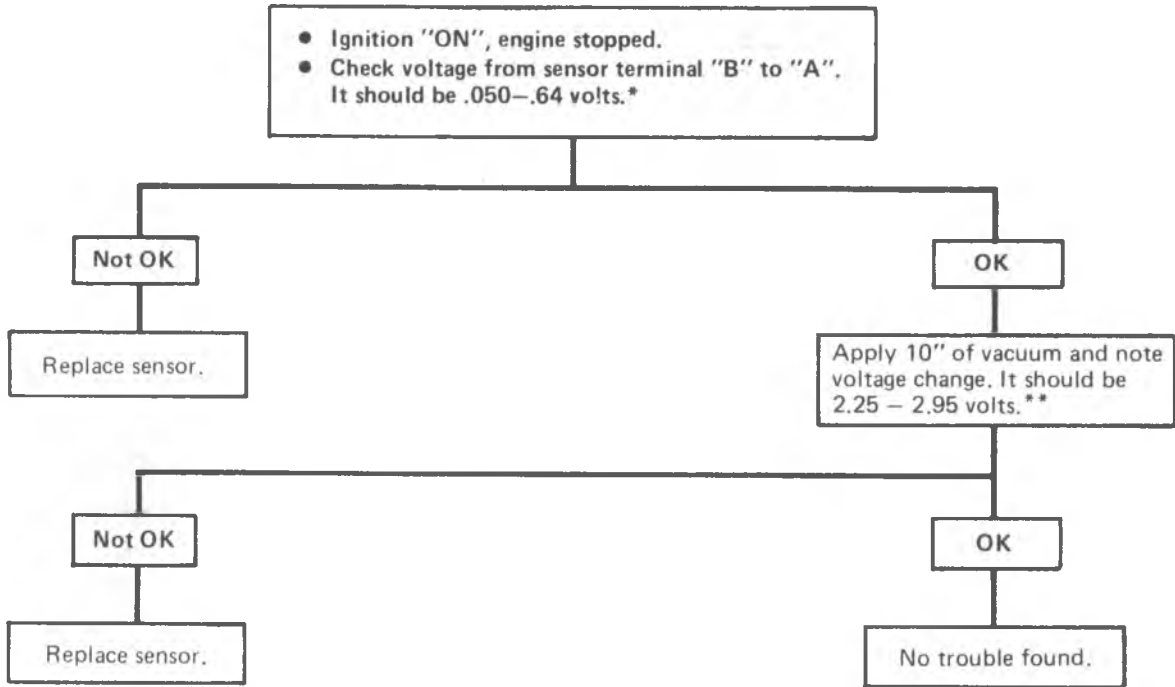

Fig. 6E1-36--Chart 6 - Won't Flash Code 12



1983 CCC  
CHART NO. 8  
VACUUM SENSOR CHECK



\* This requires use of three jumpers between the sensor and the connector.  
They can be made using terminals 12014836 and 12014837.

\*\* If voltage does not immediately follow vacuum change, sensor is faulty.

12382Z

104783

Fig. 6E1-37--Chart 8 - Vacuum Sensor Circuit

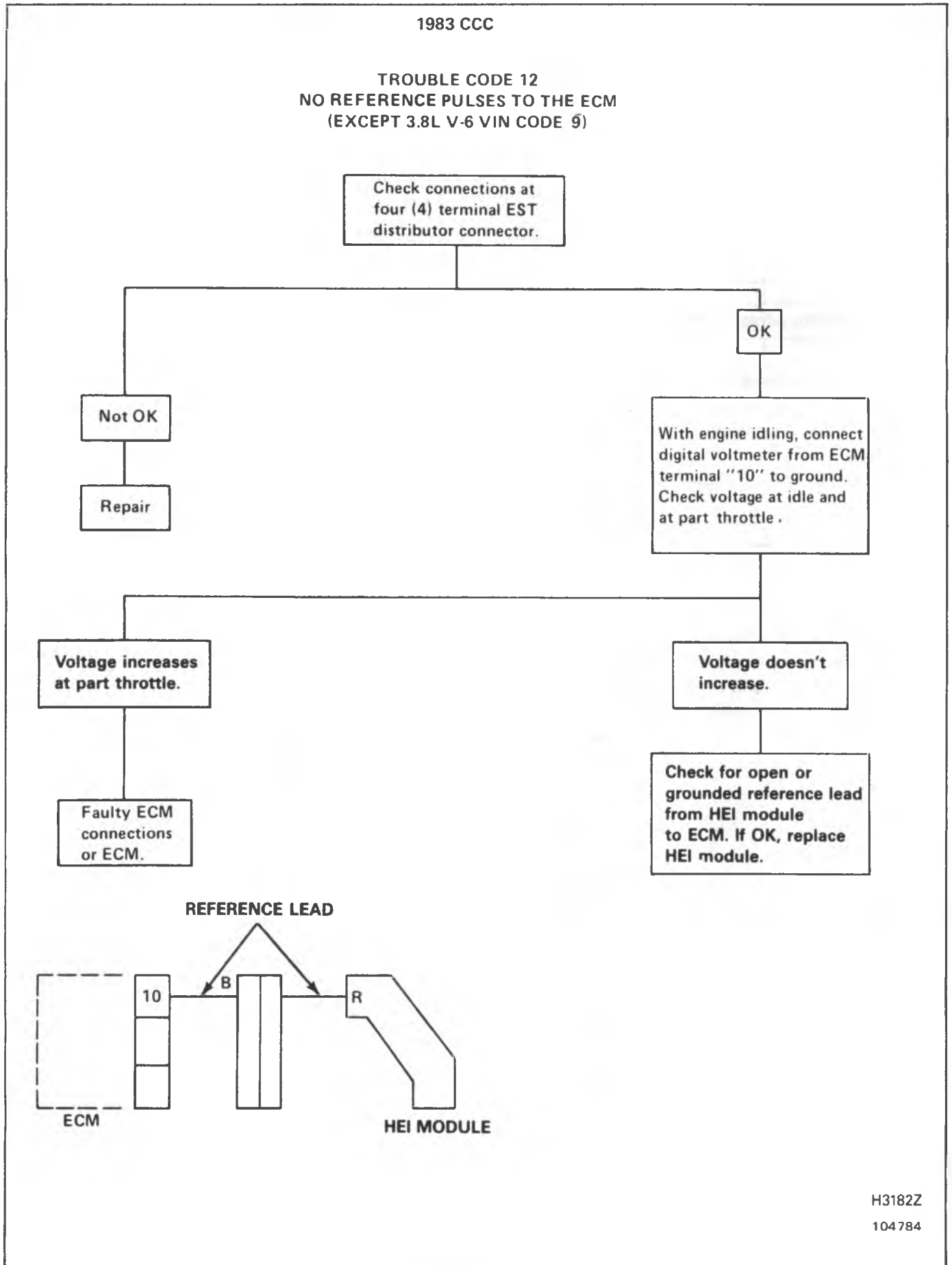

H3182Z

104784

Fig. 6E1-38--Trouble Code 12

**1983 CCC  
TROUBLE CODE 13  
(OPEN OXYGEN SENSOR CIRCUIT)**

Check for sticking or misadjusted throttle position sensor.

If 13 and 21 are displayed, go to 21 first.

- Connect dwell meter to M/C Sol., use 6-cyl. scale.
- Ground "test" terminal and note dwell at part throttle.

**Varying within 10°-50°**

Trouble is intermittent. Oxygen sensor circuit is OK at present. Check oxygen sensor circuit for intermittent connection. Clear memory.

**Fixed under 10°**

See Chart #1

**Fixed About 30**

With engine idling, disconnect oxygen sensor and ground purple wire leading to ECM (not oxygen sensor).

**Under 10° dwell.**

- Leave purple wire grounded.
- Check voltage from oxygen sensor to ground with digital voltmeter on 2 volt scale. It should read over .8 volts.

**OK**

Faulty oxygen sensor connections or sensor.

**Not OK**

Replace oxygen sensor.

**Over 10° dwell.**

Check voltage from ECM terminal "14" to ground.

**Under 1 volt**

Connect jumper between ECM terminals "9" and "14."

**Over 10° dwell.**

Faulty ECM connections or ECM.

**Over 1 volt**

Repair open between ECM terminal "14" and ground.

**Under 10° dwell.**

Repair open in oxygen sensor harness lead from connector to ECM.

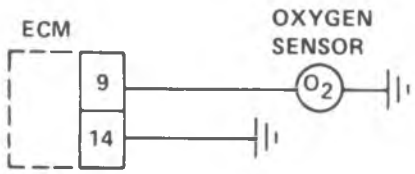

Fig. 6E1-39--Trouble Code 13

1983 CCC  
TROUBLE CODE 14  
SHORTED COOLANT SENSOR CIRCUIT

If the engine hot light is "on," check for overheating condition first.

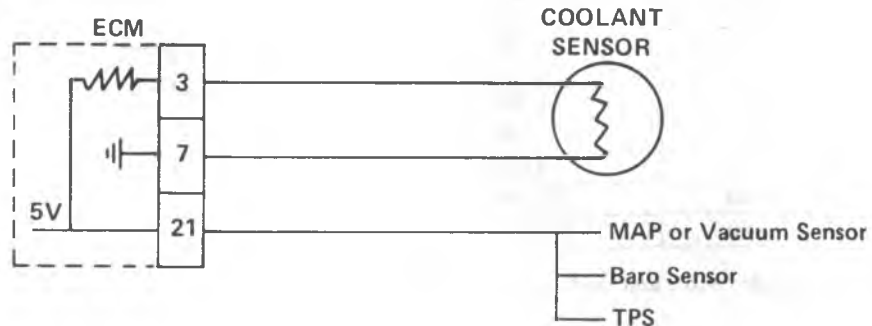
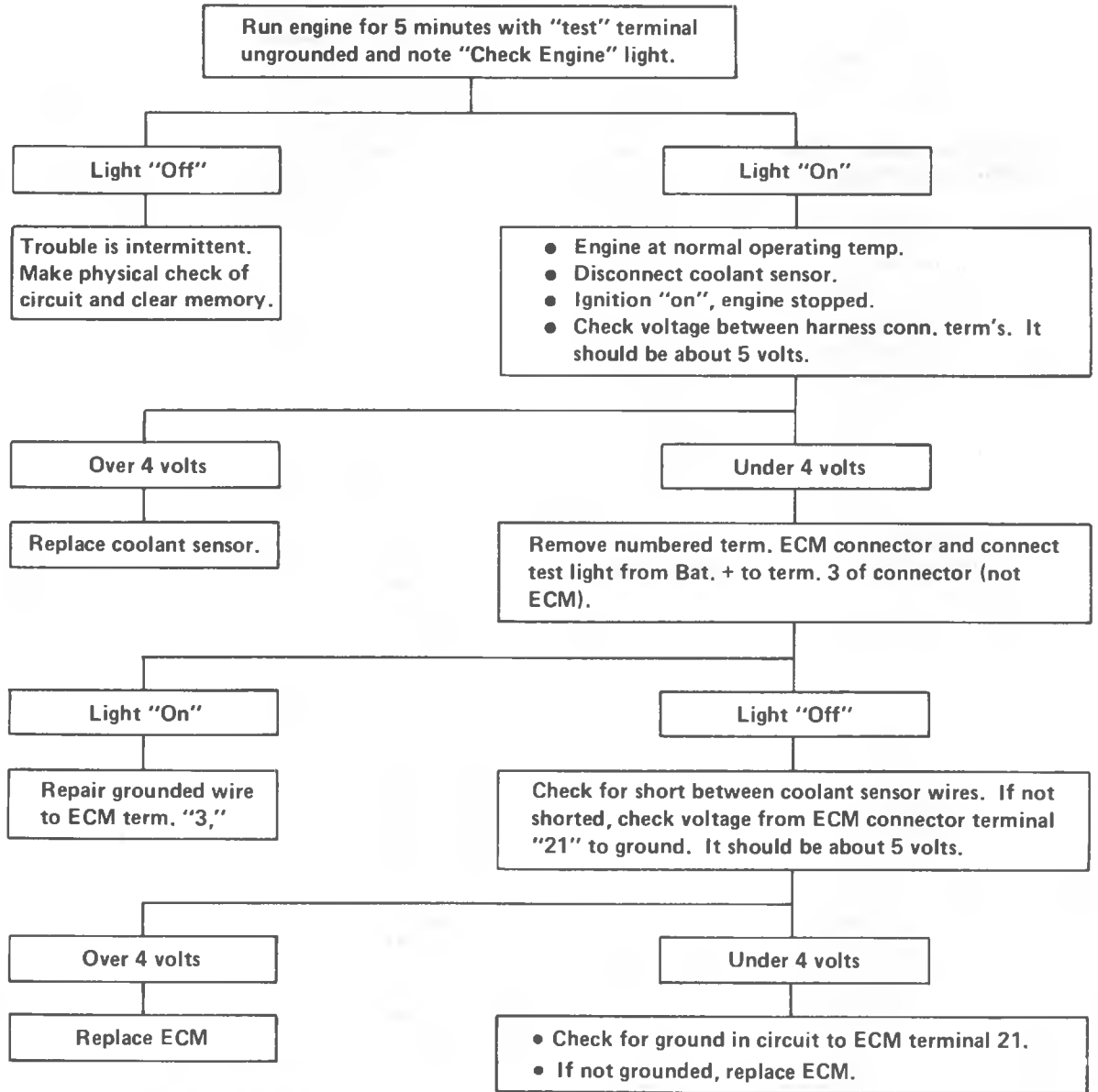
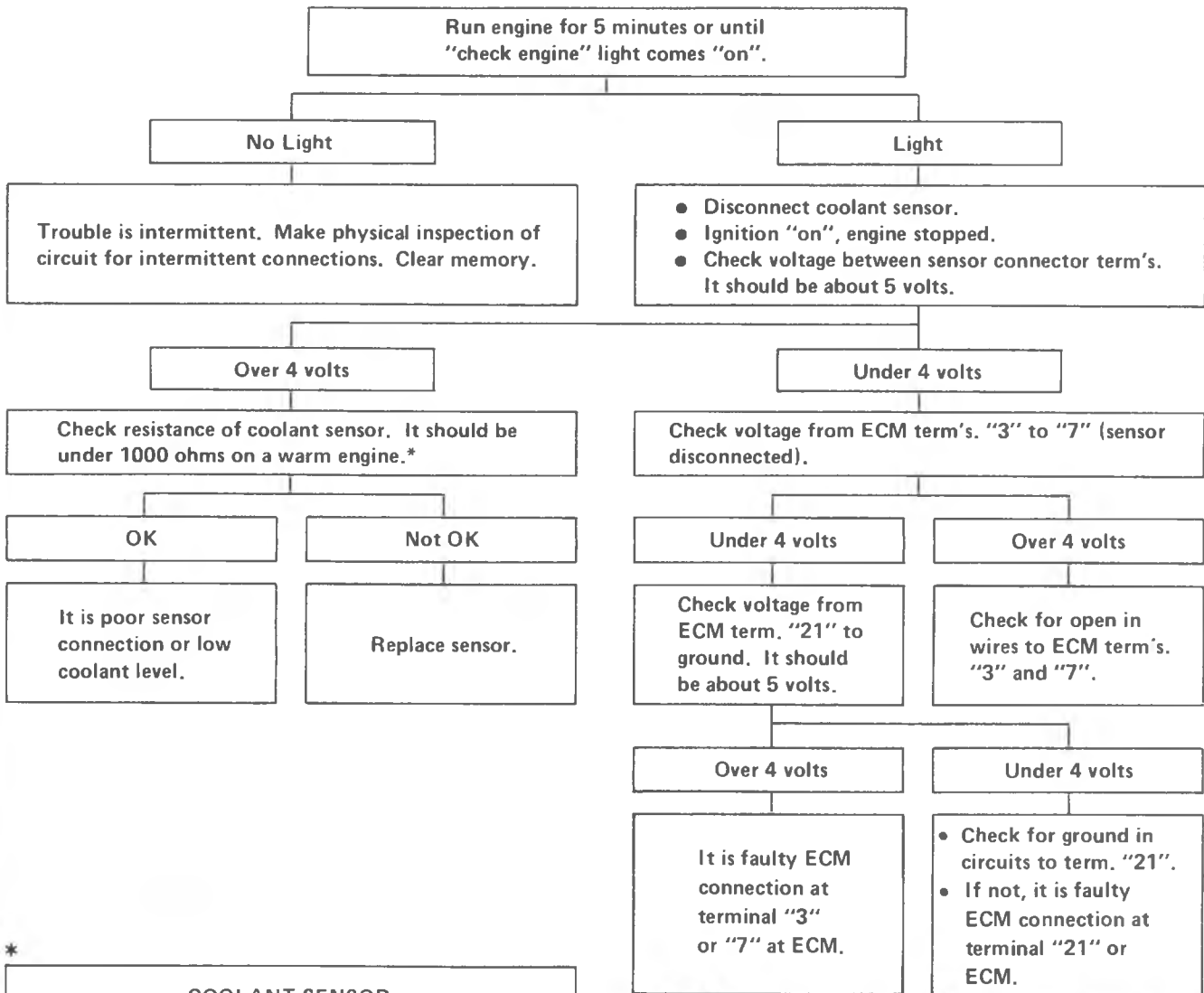

Fig. 6E1-40--Trouble Code 14

1983 CCC  
TROUBLE CODE 15  
OPEN COOLANT SENSOR CIRCUIT



\*

| COOLANT SENSOR                                 |     |         |
|--|-----|---------|
| TEMPERATURE TO RESISTANCE VALUES (APPROXIMATE) |     |         |
| °F   | °C  | OHMS    |
| 210  | 100 | 185     |
| 160  | 70  | 450     |
| 100  | 38  | 1,600   |
| 70   | 20  | 3,400   |
| 40   | -4  | 7,500   |
| 20   | -7  | 13,500  |
| 0  | -18 | 25,000  |
| -40  | -40 | 100,700 |

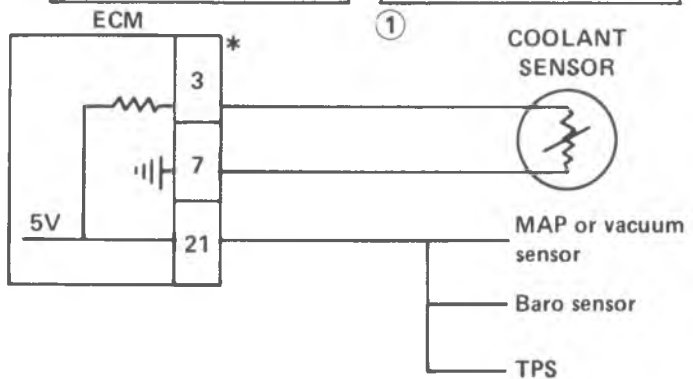

\*This may require use of connector and lead assembly 12026621.

11-18-82Z  
104788

Fig. 6E1-41--Trouble Code 15

1983 CCC  
TROUBLE CODE 21  
OPEN TPS CIRCUIT OR MISADJUSTED

Check for stuck or misadjusted TPS Plunger.  
Repair as necessary. If OK, proceed:

- Connect dwell meter to M/C solenoid — use 6-cyl. scale.
- Disconnect TPS harness connector from sensor.
- Check voltage from harness connector terminal "B" to "C" with a digital voltmeter.
- Ignition on, Engine stopped.

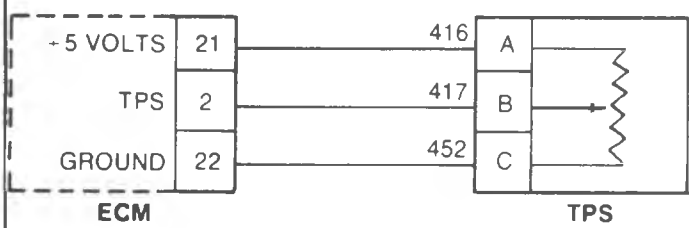
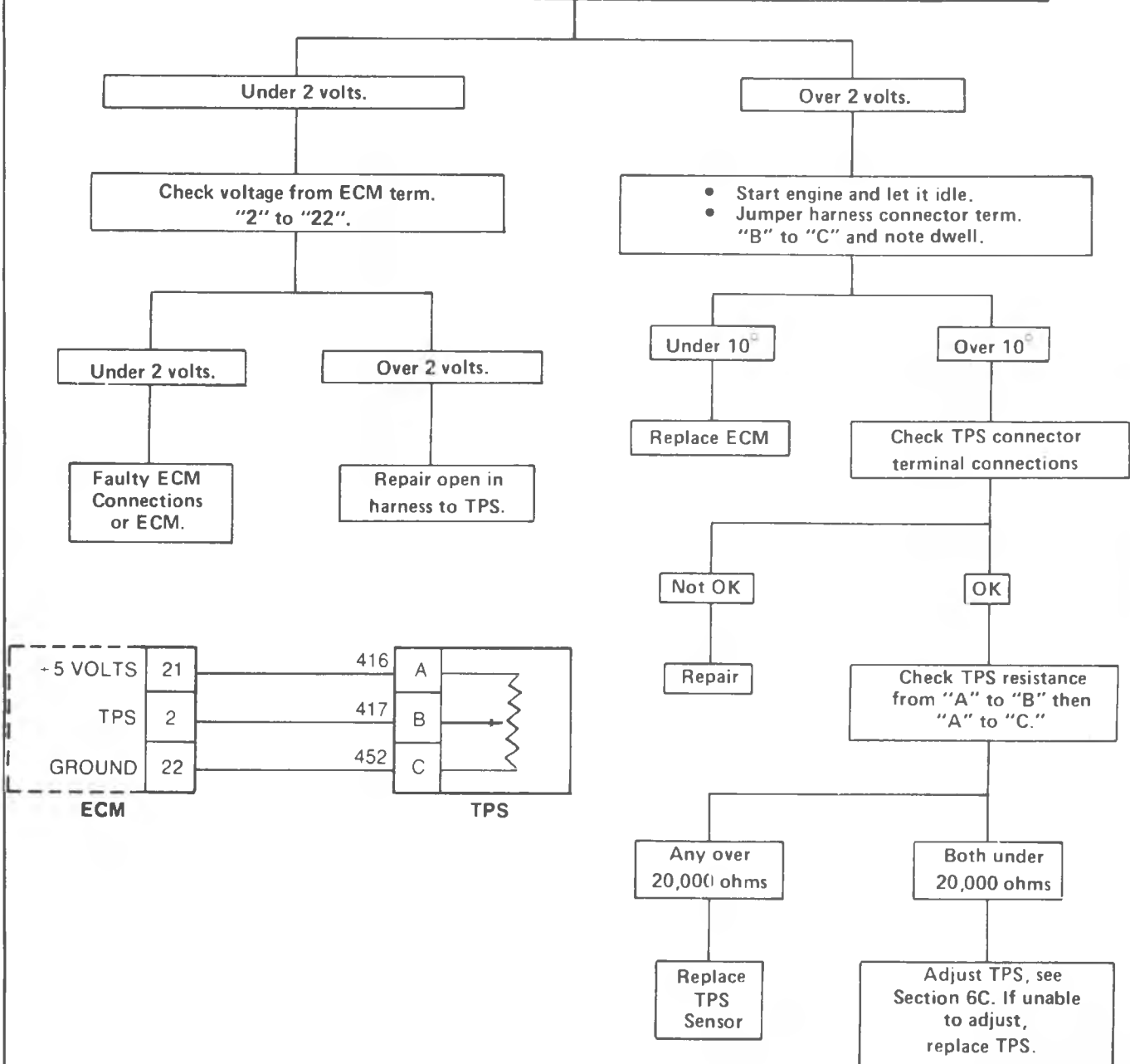

Fig. 6E1-42--Trouble Code 21

1983 CCC  
TROUBLE CODE 23

OPEN OR GROUNDED M/C SOLENOID CIRCUIT

Check connections at M/C solenoid. If O.K.: Clear memory\* and recheck for code(s). If no code 23, circuit is OK.

- Turn ignition "on", engine stopped.
- Do not ground "Test" terminal.
- Check voltage at M/C solenoid dwell lead after M/C solenoid stops cycling (after 25 sec., if applicable)

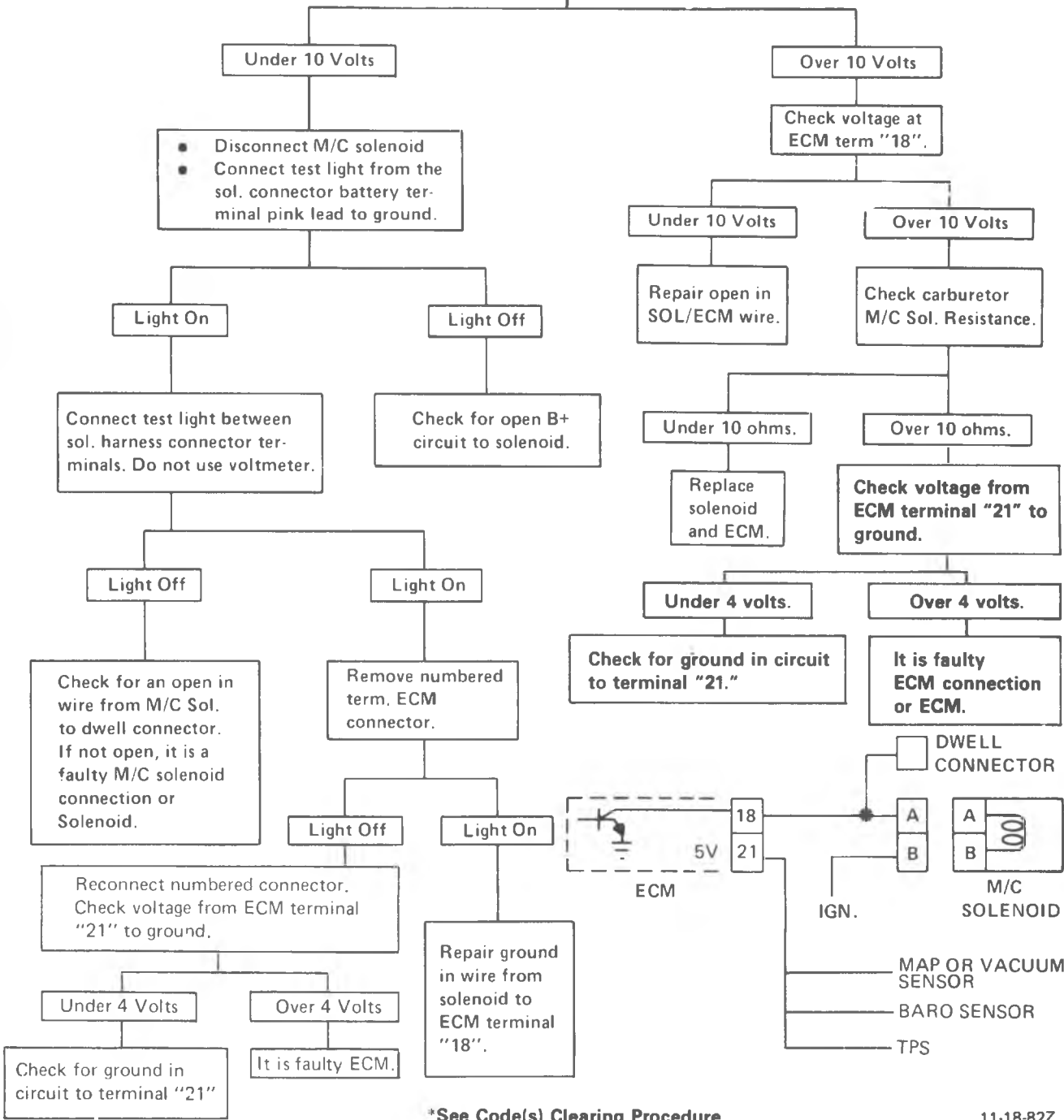

\*See Code(s) Clearing Procedure

Fig. 6E1-43--Trouble Code 23

1983 CCC  
TROUBLE CODE 34  
VACUUM SENSOR VOLTAGE TOO HIGH OR LOW

Check for over 34 kPa (10 inches) of vacuum at sensor with engine idling. If not OK, repair.

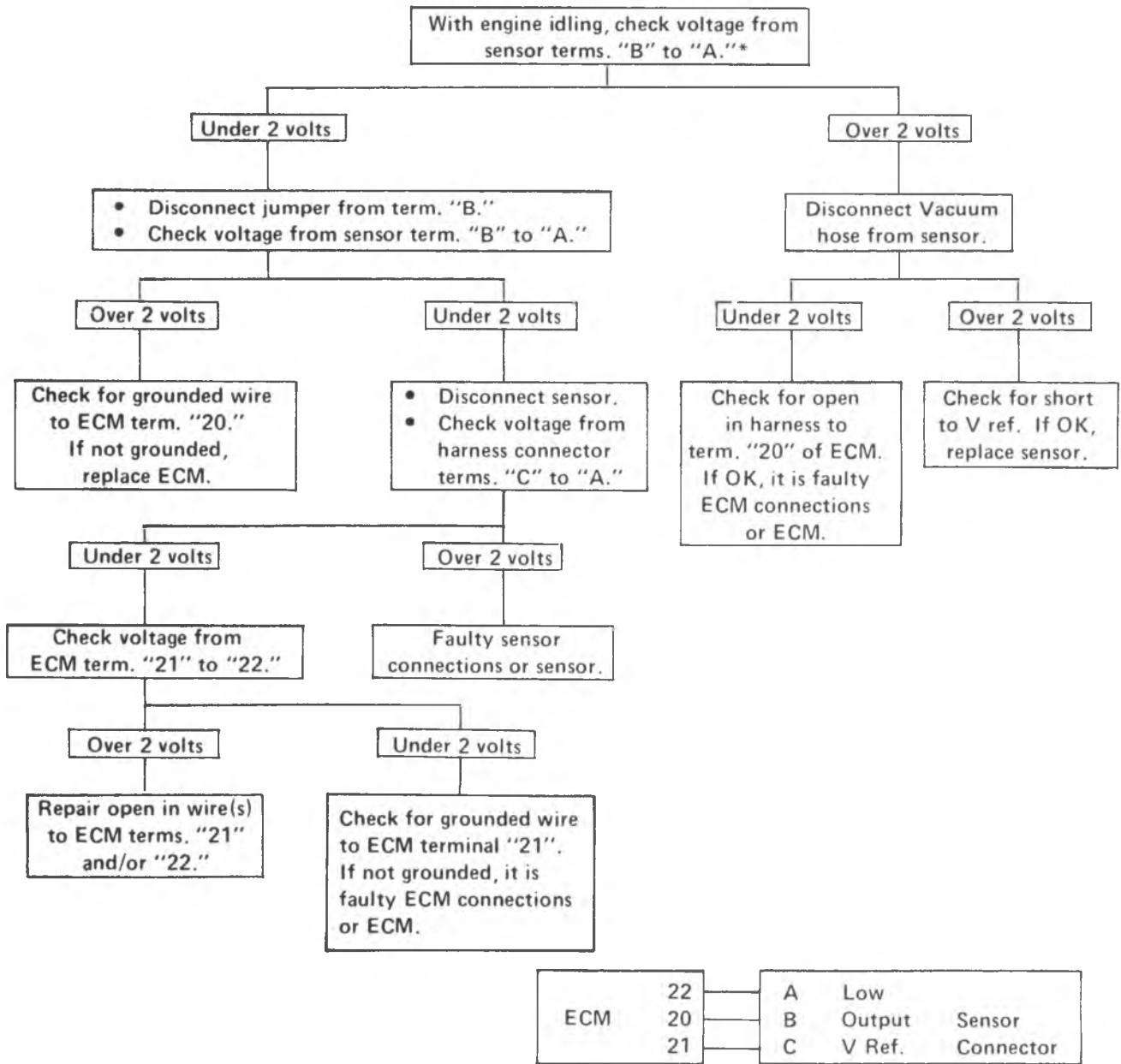

High Vacuum = High Output

\*This requires use of three jumpers between the sensor and the connector. They can be made using terminals 12014836 and 12014837.

Fig. 6E1-44--Trouble Code 34



1983 CCC  
TROUBLE CODE 41  
NO DISTRIBUTOR REFERENCE SIGNAL

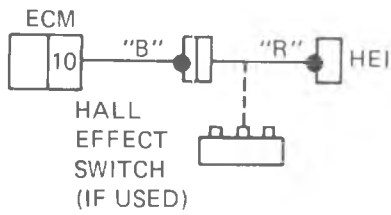
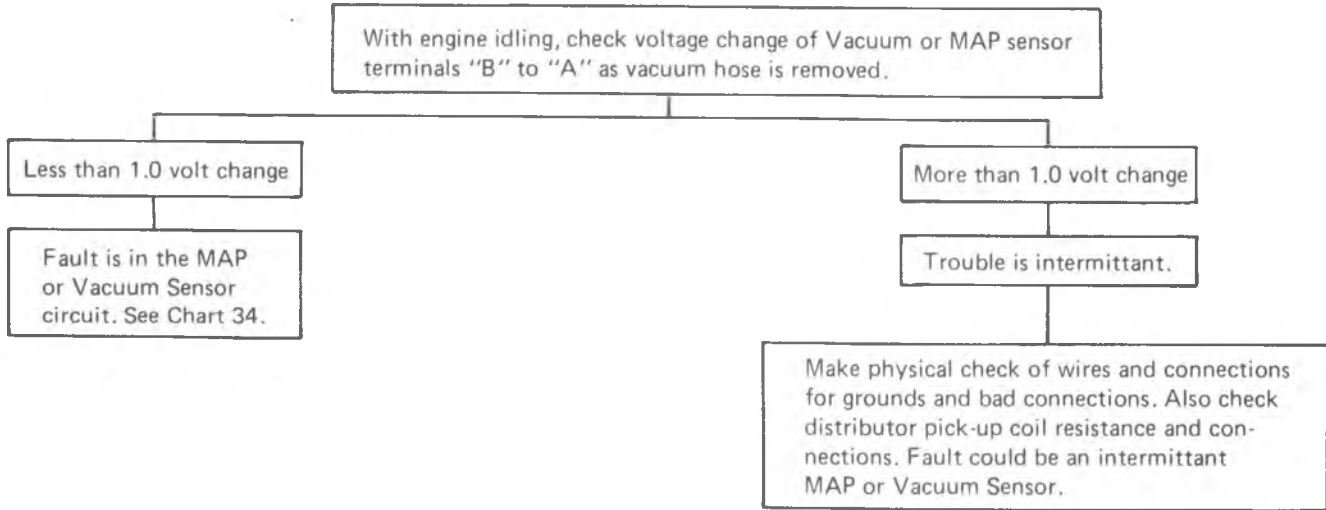

11-18-82Z  
104155

Fig. 6E1-45--Trouble Code 41

**TROUBLE CODE 42  
BYPASS OR EST PROBLEM**

If vehicle will not start and run, check for grounded EST wire to ECM terminal "12." (Grounded and open EST circuit on 5.0L VIN "Y".)

A 1981 HEI module can cause a Code 42.

With engine at fast idle, note timing. Ground "test" terminal and note timing; it should change.

No change

OK

No trouble found

- Disconnect 4 terminal EST connector from distributor.
- With engine stopped, connect jumper from "A" to "B" in distributor side of EST connector.
- Start engine, ground "test" terminal and connect test light from Battery + to term. "C" of same conn.

Engine stops

Engine runs

Check for open EST wire to terminal "E" of HEI module. If wire is OK, it is faulty HEI module connection or module.

With test light still connected, remove jumper between terminals "A" and "B."

Engine runs

Engine stops

- Check distributor wires for:
- Open or ground to module terminal "B".
  - Short between module terminals "R" and "E". If wires are OK, it is faulty HEI module connection or module.

- Check for correct HEI module.
- Check for open wire from EST Connector terminal "A" to ECM terminal "12".
- Check for open or ground wire from EST Connector terminal "C" to ECM terminal "11".

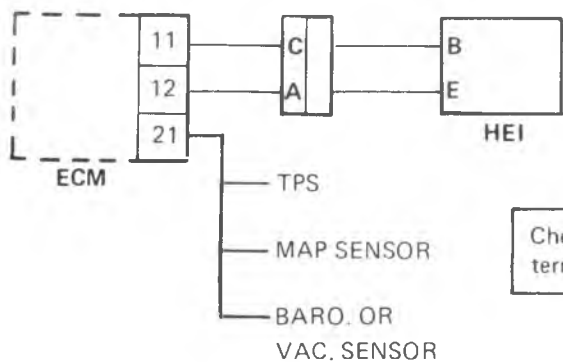

If not grounded or open, check for voltage from terminal "21" to ground.

If grounded or open

Repair

Under 4.5 volts

Over 4.5 volts

Check for grounded wire to ECM term. "21"

It is faulty ECM connection or ECM.

11-18-82Z  
104797

Fig. 6E1-46--Trouble Code 42

1983 CCC

**TROUBLE CODE 44  
LEAN EXHAUST INDICATION**

- If M/C solenoid does not click with ignition "ON" and "TEST" term. grounded, and there is no code 23 or 54, check for sticking M/C solenoid.

- Ground test terminal.
- Connect dwell meter to M/C solenoid – use 6-cylinder scale.
- Run engine at 3000 RPM in closed loop and note dwell.

Between 10-50°

Under 10°

Check for cause of intermittent lean condition such as faulty carb base gasket leaking vacuum hoses, or leaky intake gasket. If no leaks are found, replace oxygen sensor.

With engine at part throttle, choke engine

Dwell Increases to Over 50°

Dwell did not reach 50°

- Check for air leak (including air management system to exhaust ports at 3000 RPM and decel valve if used).
- Check for exhaust leak.

- Disconnect oxygen sensor.
- Connect digital multimeter J291125-A or equivalent and set on the 20 volt scale, from bat. + to purple wire to ECM (not oxygen sensor).\*
- Note dwell, at part throttle.

No leak

Leak

Increases

Under 10°

See Carburetor Calibration Procedure Section 6C.

Repair

Check for an open from ECM term. "14" to ground. If not open, replace oxygen sensor.

Check for open from ECM term. "14" to ground and grounded purple wire to ECM term. "9". If circuits are OK, it is faulty ECM connection or ECM.

\* Do Not use an ordinary voltmeter or jumper in place of the digital voltmeter because they have too little resistance. A voltage source of 1.0V to 1.7V (such as a flashlight battery) can be connected with the Positive terminal to the purple wire and the negative terminal to ground as a jumper. If the polarity is reversed, it won't work.

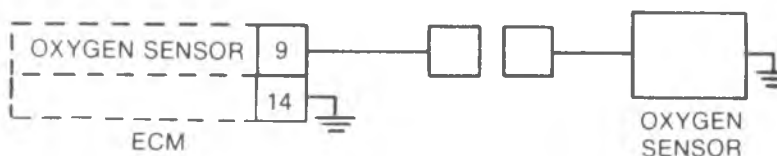

K0182Z  
104799

Fig. 6E1-47--Trouble Code 44

**TROUBLE CODE 45  
RICH EXHAUST INDICATION  
(CKG TRUCK ONLY)**

- If M/C solenoid does not click with ign. "ON" and "TEST" term. grounded, and there is no Code 23 or 54, check for sticking M/C solenoid.
- If Code 54 is present, go to Chart 54 first.

• Connect dwell meter to M/C sol. — use 6 cyl. scale.  
• Run at 3000 RPM in Park or Neutral and note dwell.

Under 50°

• Trouble is intermittent. System is OK at present.  
• Clear memory.

Over 50°

• Return to idle.  
• Place a .075" to .100" drill or equivalent as a spacer between the accelerator pump lever and TPS plunger.  
• Remove large vacuum hose such as PCV but not enough to stall the engine.  
• Note dwell, should drop at least 20°

Dwell drops 20°

• Check that pink wire is attached to right-hand term. of M/C solenoid connector, as viewed from harness end.  
• Check evaporator canister for being loaded with fuel and related valves, such as purge and bowl vent, for leaks which would cause richness, also fuel in crankcase. If OK, see Carburetor On-Vehicle Service—Section 6C.

Does not drop 20°

• Disconnect oxygen sensor.  
• Ground harness connector terminal on lead to ECM (not oxygen sensor).

Dwell Drops to Under 10°

• Ignition "ON", engine stopped.  
• Remove ground from oxygen sensor harness connector and check voltage from that term. to ground with digital voltmeter.

No Dwell Change

Replace ECM

Under .55V

It is faulty oxygen sensor.

Over .55V

• Check wire from ECM term. 9 for short to Bat. +.  
• If not shorted, it is faulty ECM.

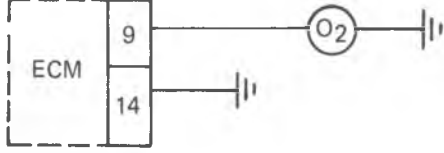
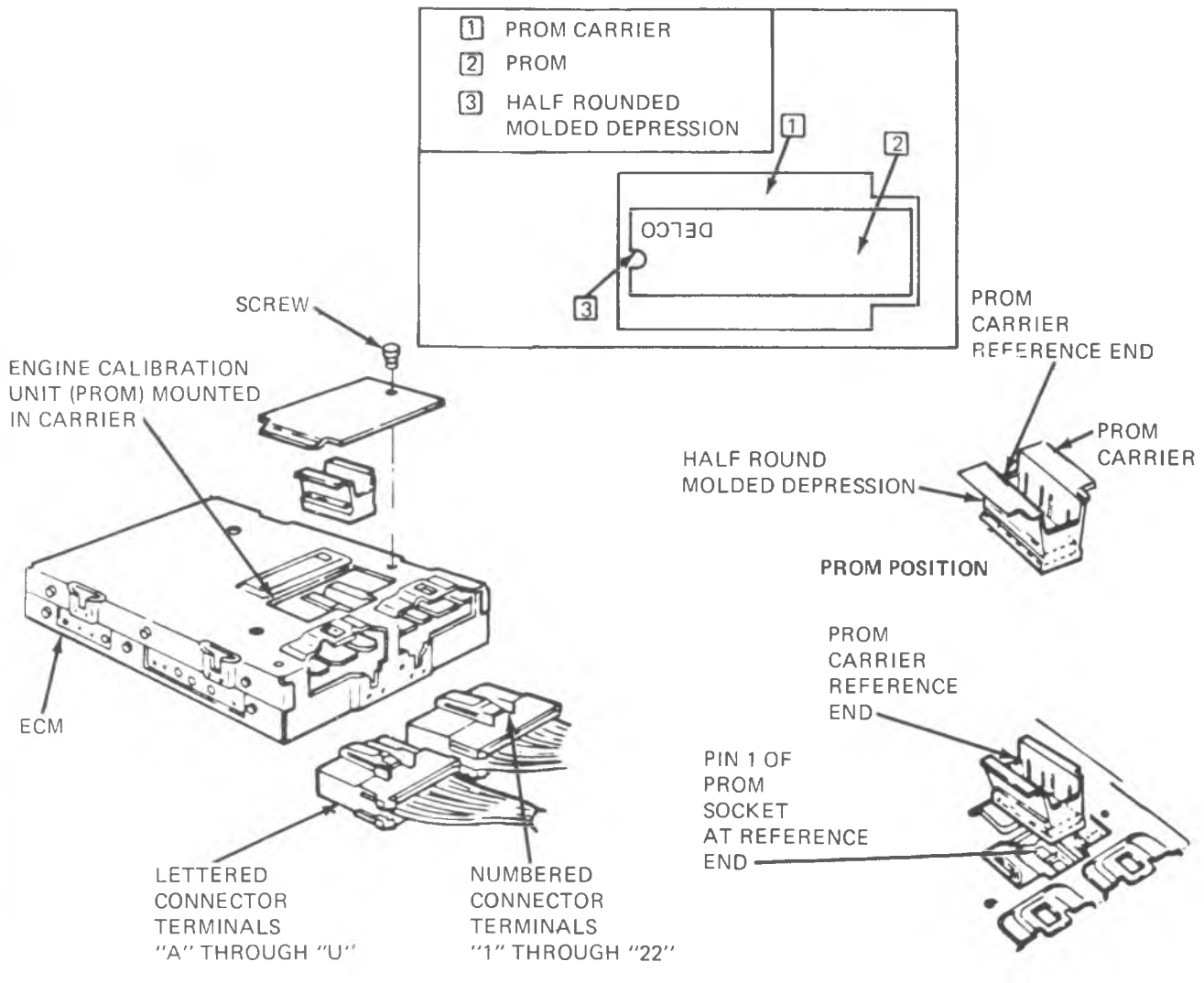

Fig. 6E1-48--Trouble Code 45

**TROUBLE CODE 51  
PROM PROBLEM**

Check that all pins are fully inserted in the socket. If OK, replace PROM and recheck, if problem not corrected, replace ECM.



ANYTIME THE PROM IS INSTALLED BACKWARDS AND THE IGNITION SWITCH IS TURNED ON, THE PROM IS DESTROYED.

11-18-82Z  
104275

Fig. 6E1-49--Trouble Code 51

1983 CCC  
TROUBLE CODE 54  
CONSTANT HIGH VOLTAGE FROM  
M/C SOLENOID-TO-ECM

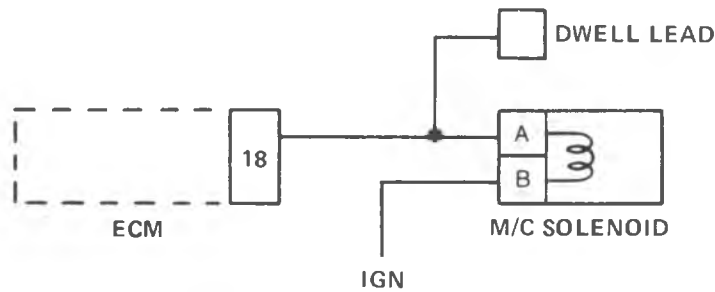
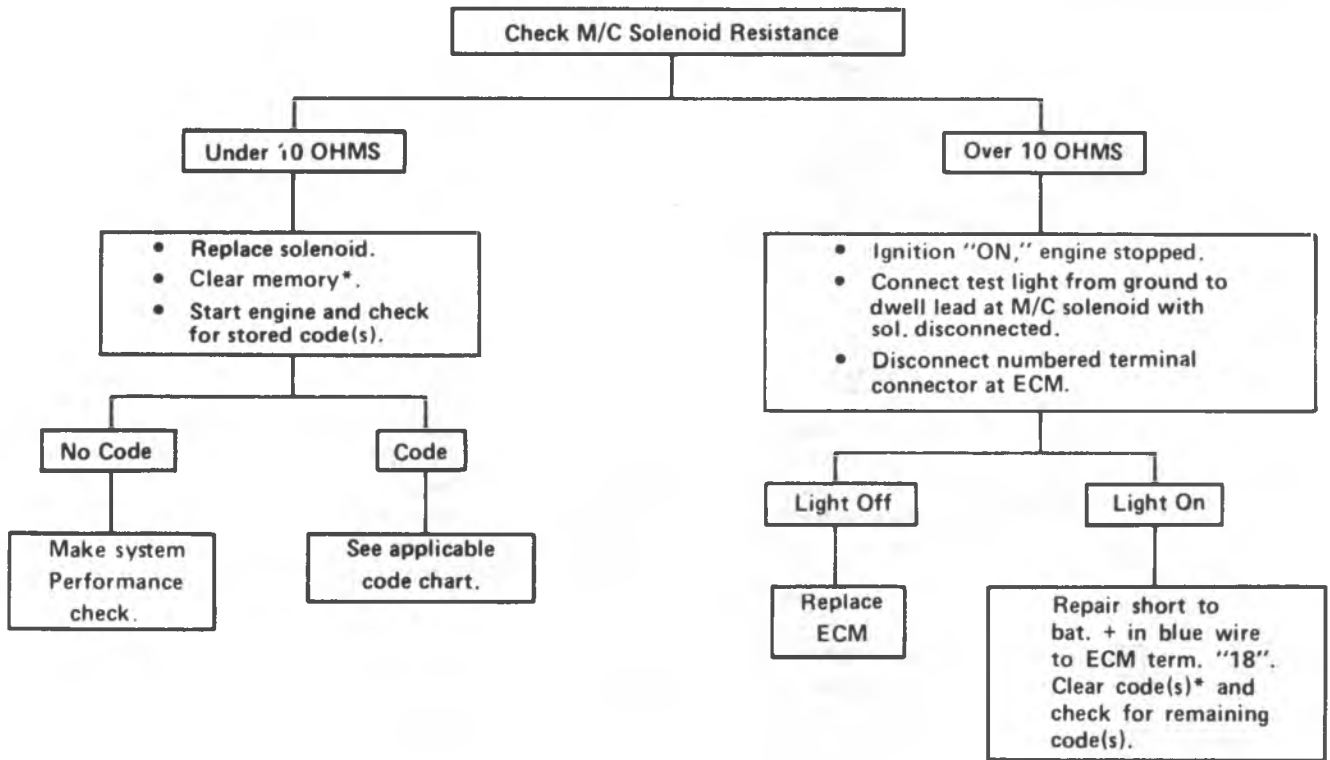

\*See Code(s) Clearing Procedure

11-18-82Z  
104801

Fig. 6E1-49A--Trouble Code 54

1983 CCC  
TROUBLE CODE 55

High voltage on oxygen sensor circuit or wrong voltage on ECM terminal 21.

Check for corrosion at ECM edgeboard connectors and terms. If present, check for coolant sensor, windshield or heater core leaks. Repair leak, clean connector terms, and replace ECM. Also, check for 4 term. EST harness being too close to electrical signals, such as spark plug wires, distributor housing, generator, etc.

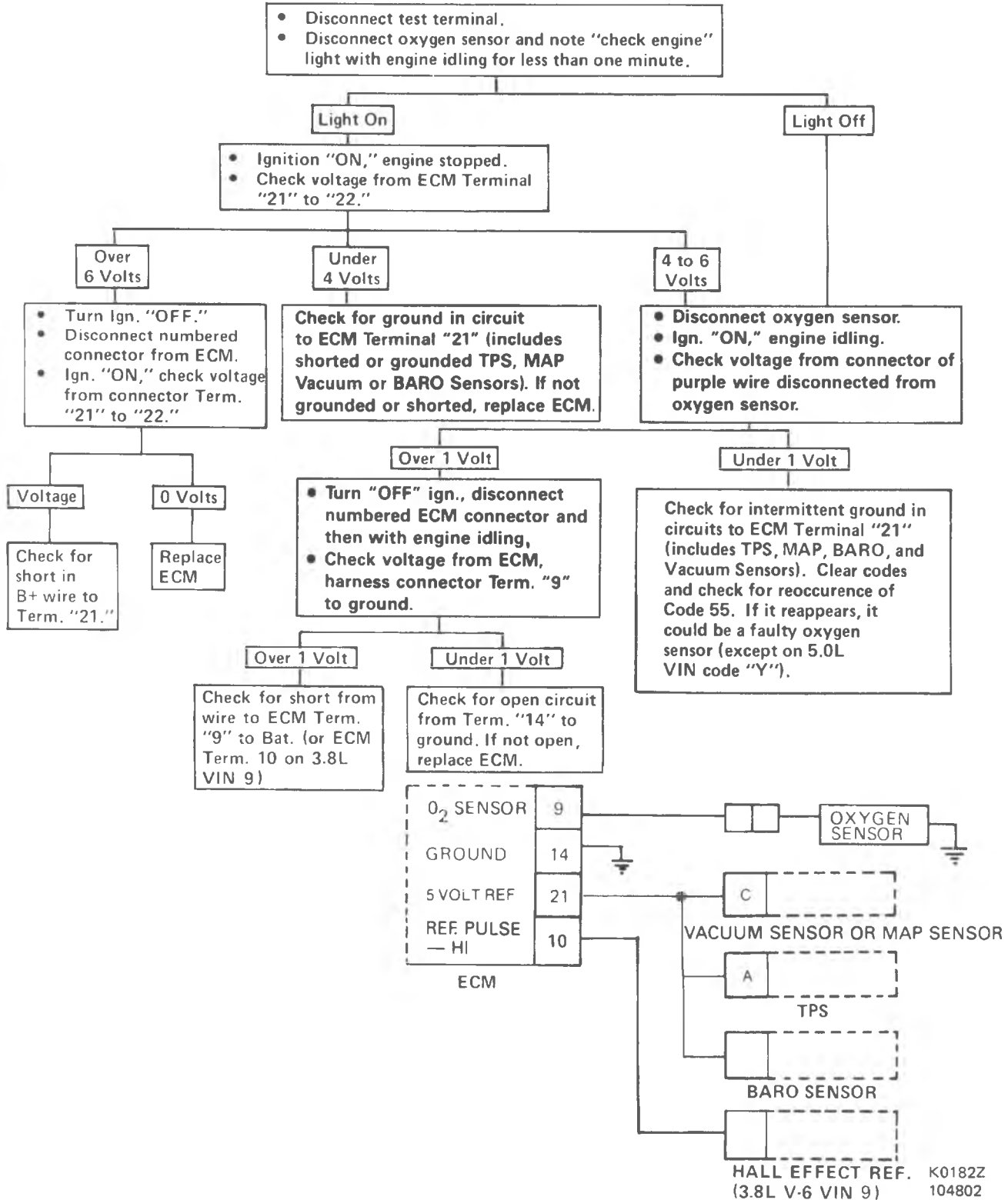

Fig. 6E1-50--Trouble Code 55

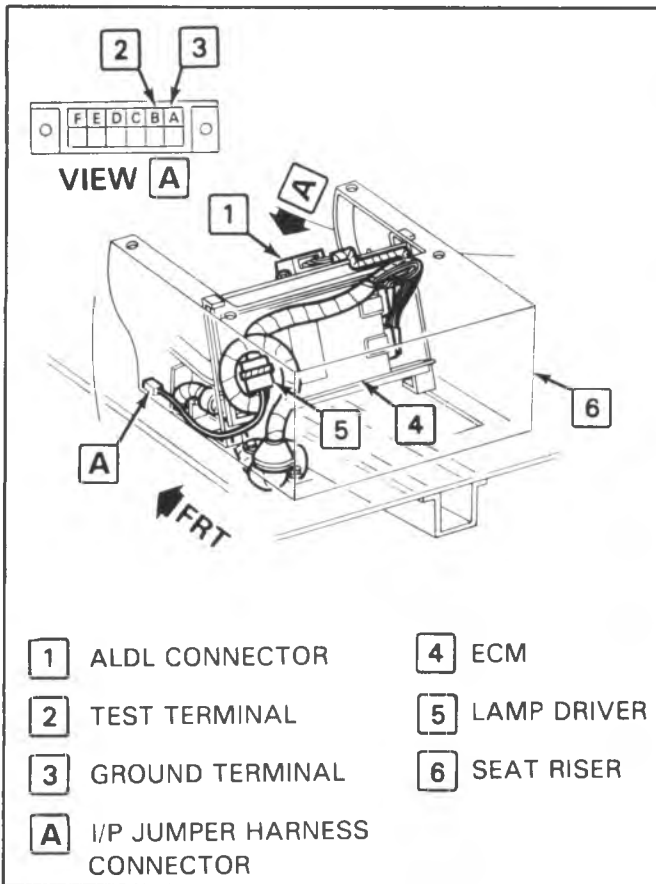

Fig. 6E1-51 -- ECM Location G

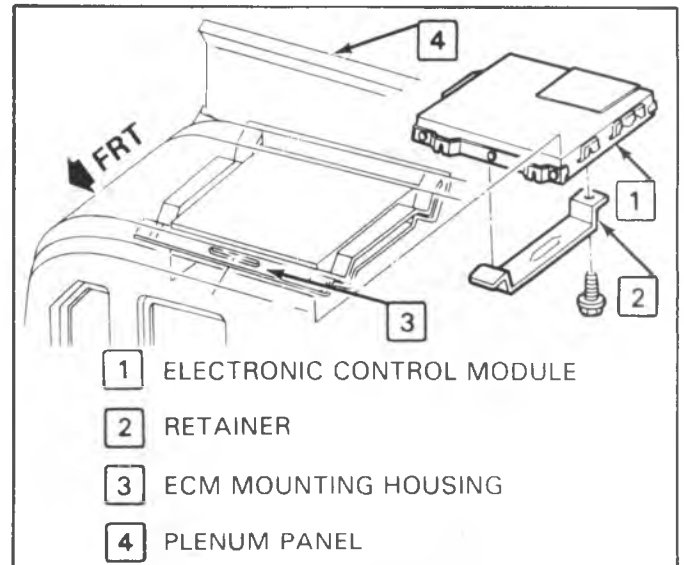

Fig. 6E1-51a -- ECM Location C-K



**1983 CCC C-K-G TRUCK  
ECM TERMINAL IDENTIFICATION**

**VIEW — TOP OF BOX**

Sensor Return  
 5V Reference  
 Vacuum Sensor Output  
 Not Used  
 M/C Solenoid  
 Not Used  
 Not Used  
 Not Used  
 Oxygen Sensor — Lo  
 Dist. Ref. Pulse — Lo  
 EST

**CONNECTOR**

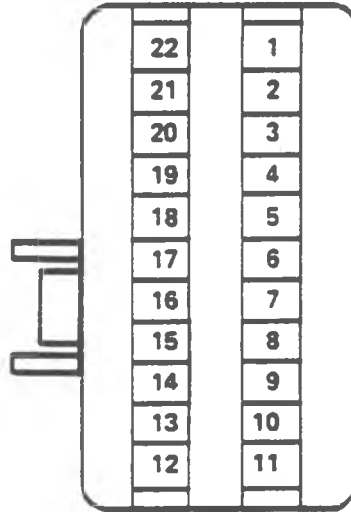

**VIEW — BOTTOM OF BOX**

Not Used  
 TPS Sensor Output  
 Coolant Temp. Sensor  
 Air Control Relay (L6G w/MT)  
 Trouble Code Test Terminal  
 Not Used  
 Coolant Temp. Sensor Return  
 Not Used  
 Oxygen Sensor — Hi  
 Distributor Reference Pulse — Hi  
 Ignition Module By-Pass

Not Used  
 Not Used  
 "Check Engine" Lamp  
 Not Used  
 Not Used  
 Not Used  
 Ign. 1 Power  
 Air Divert Solenoid  
 Ground to Engine

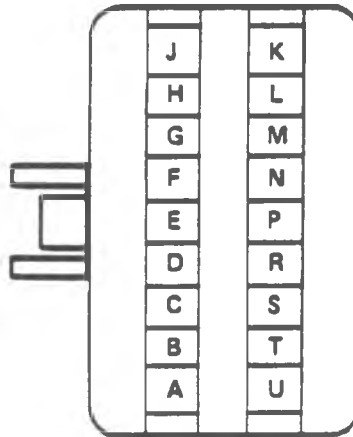

Not Used  
 Not Used  
 Not Used  
 Not Used  
 Transmission Converter Clutch Solenoid  
 Trouble Code Memory Power  
 Not Used  
 Air Control Relay (L6G w/MT or Canister  
 Purge Solenoid [V8])  
 Ground to Engine

Fig. 6E1-52—ECM Terminal Identification

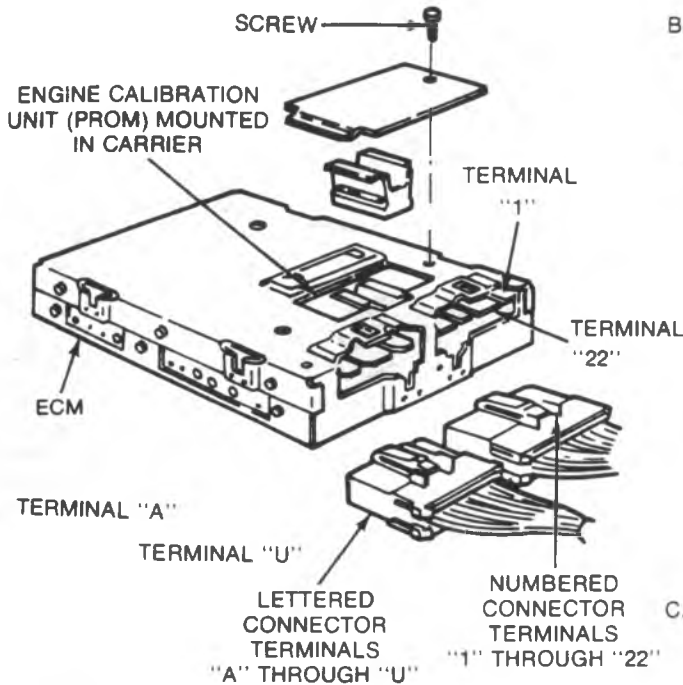
**ELECTRONIC CONTROL MODULE (ECM) REPLACEMENT**

- ELECTRONIC CONTROL MODULE (ECM) MOUNTING HARDWARE NOT ILLUSTRATED. HARDWARE CONFIGURATION WILL VARY WITH CAR DIVISION.

1. Disconnect the two connectors from the ECM. One is numbered and the other is lettered.
2. Remove the ECM mounting hardware.
3. Remove the ECM from the passenger compartment.
4. Remove the one sheet metal screw holding the access cover closed.
5. Remove the access cover.

- REPLACEMENT ELECTRONIC CONTROL MODULE (ECM) IS SUPPLIED WITHOUT AN ENGINE CALIBRATION UNIT (PROM) SO CARE SHOULD BE TAKEN WHEN REMOVING THE PROM FROM THE DEFECTIVE ECM AS IT WILL BE REUSED IN THE NEW ECM.

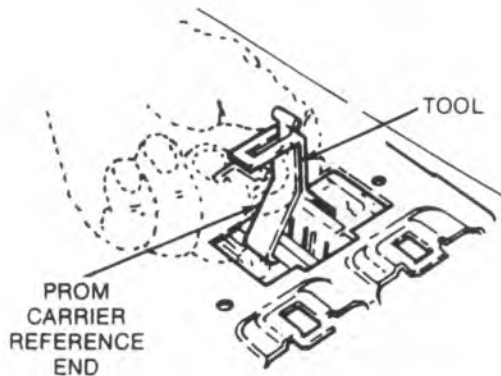

1. Grasp the engine calibration unit (PROM) carrier with the PROM removal tool. Gently rock the carrier from side to side while applying a firm upward force and remove the defective PROM.
2. Note the reference end of PROM carrier (squared off symmetrical end) and carefully set aside.

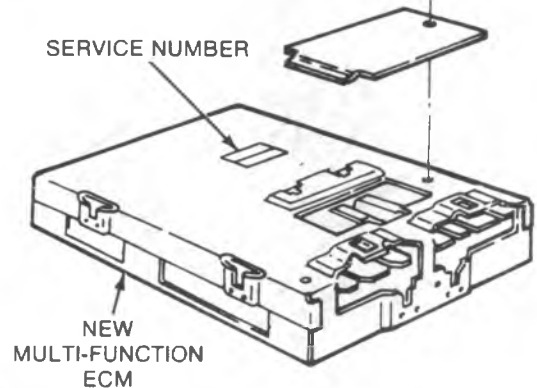

1. Take the new electronic control module out of its packaging and check the service number to make sure it is the same as the defective ECM.

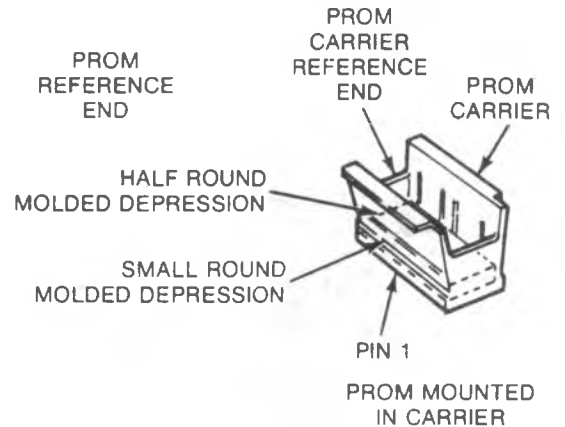

1. Take the PROM mounted in the PROM carrier (which you had previously set aside) and check that the molded half round depression on the PROM is at the squared off symmetrical end of the carrier. Also make sure there is equal space between the ends of the PROM and the carrier.

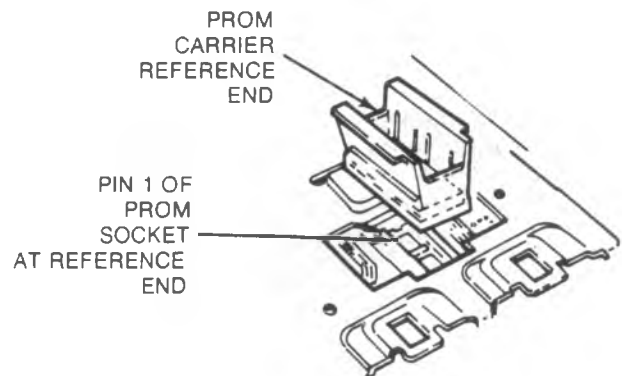
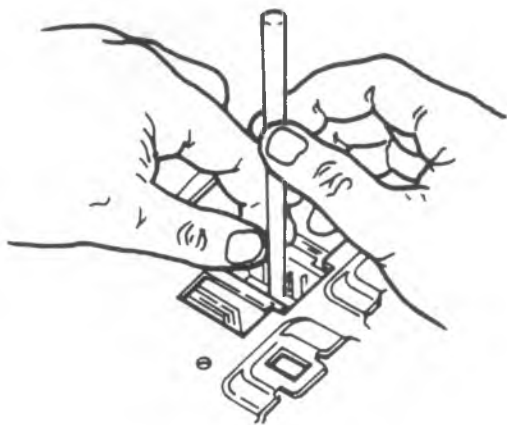

Fig. 6E1-53--PROM Replacement (1 of 2)

- E. 1. Position the carrier squarely over the PROM socket with the squared off symmetrical end of the carrier aligned with the small notch in the socket at the pin 1 end.



2. Press down firmly on the top of the carrier.



3. While firmly pressing down on the carrier, take a narrow blunt tool and press down on the body of the PROM. Try to seat the PROM in the socket squarely by alternately pressing on either end of it.

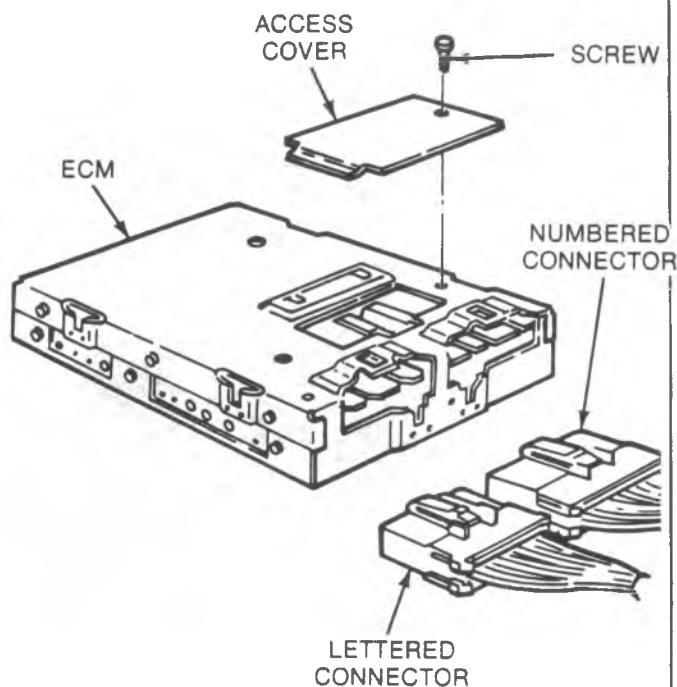

- F. 1. Replace access cover on new ECM.  
 2. Reinstall access cover fastening screw.  
 3. Reinstall new ECM in passenger compartment.  
 4. Connect the two connectors to the new ECM.  
 5. Turn ignition on and start engine.  
 6. Ground diagnostic test lead.  
 7. Look for trouble code 51. If this occurs, the PROM is not fully seated, installed backwards, has bent pin, or is defective.
- If a trouble code does not occur, the PROM is installed properly.
  - If it is necessary to remove the PROM, follow instructions in step, "A" & "B".
  - If not fully seated, press firmly on PROM.
  - If pins bend, remove PROM. straighten pins and reinstall. If bent pins break or crack during straightening, discard PROM and replace it.
  - If found defective, replace PROM.
  - If installed backwards, REPLACE THE PROM.

ANYTIME THE PROM IS INSTALLED BACKWARDS AND THE IGNITION SWITCH IS TURNED ON, THE PROM IS DESTROYED.

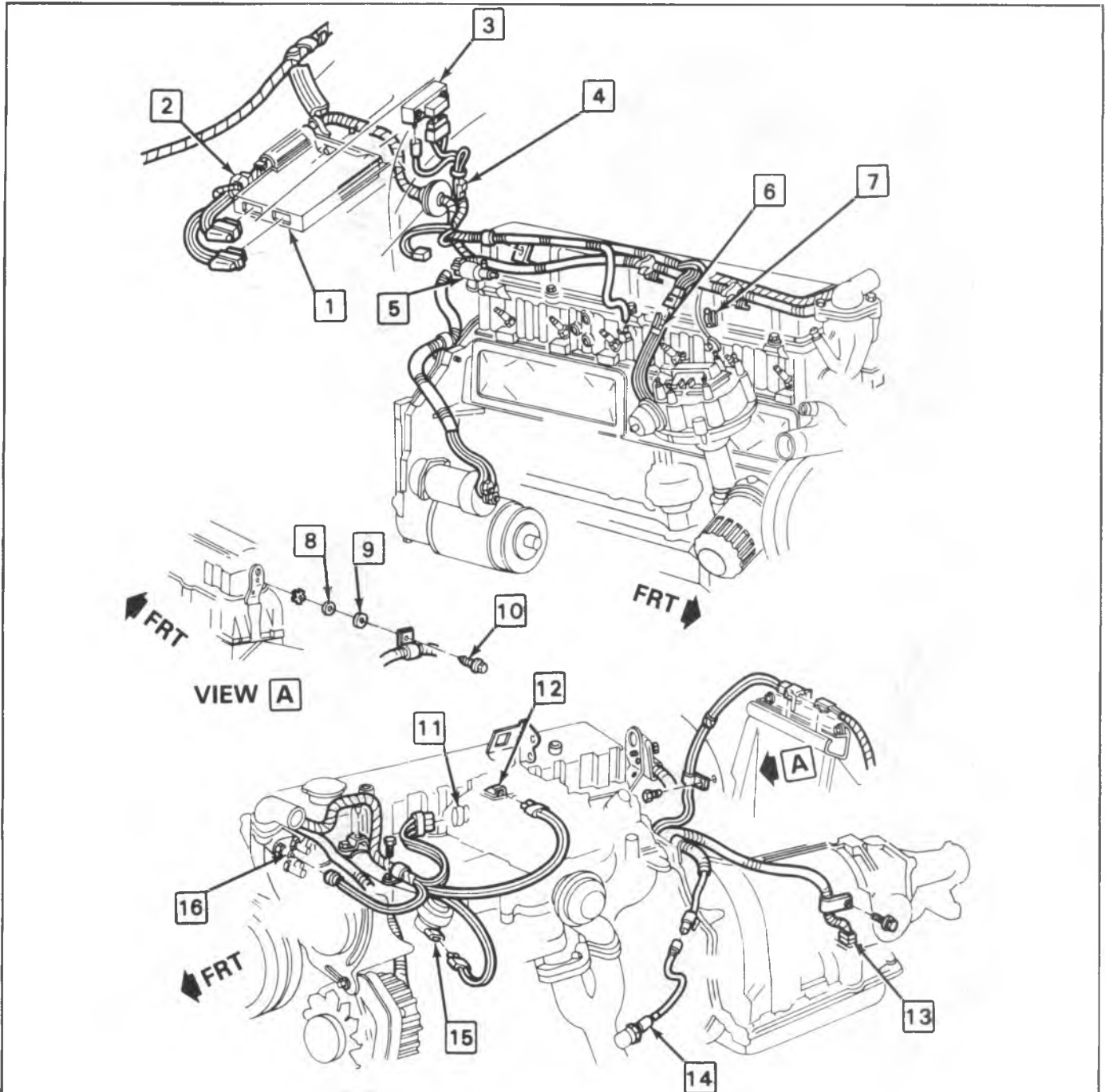

- |  |  |
|--|--|
| <b>1</b> ELECTRONIC CONTROL MODULE                   | <b>9</b> GROUND WIRE                             |
| <b>2</b> LAMP DRIVER                                 | <b>10</b> BOLT - TIGHTEN TO 33 N·m (24 FT. LBS.) |
| <b>3</b> VACUUM SENSOR                               | <b>11</b> THROTTLE POSITION SENSOR               |
| <b>4</b> DWELL METER CONNECTOR                       | <b>12</b> M/C SOLENOID                           |
| <b>5</b> EGR BLEED SOLENOID (A.T.)                   | <b>13</b> TO TCC SOLENOID                        |
| <b>6</b> EST CONNECTOR                               | <b>14</b> OXYGEN SENSOR                          |
| <b>7</b> GROUND WIRE TIGHTEN TO 33 N·m (24 FT. LBS.) | <b>15</b> AIR DIVERT SOLENOID                    |
| <b>8</b> BODY GROUND STRAP                           | <b>16</b> COOLANT SENSOR                         |

Fig. 6E1-55--Component Location - 4.1L Engine (CK Series)

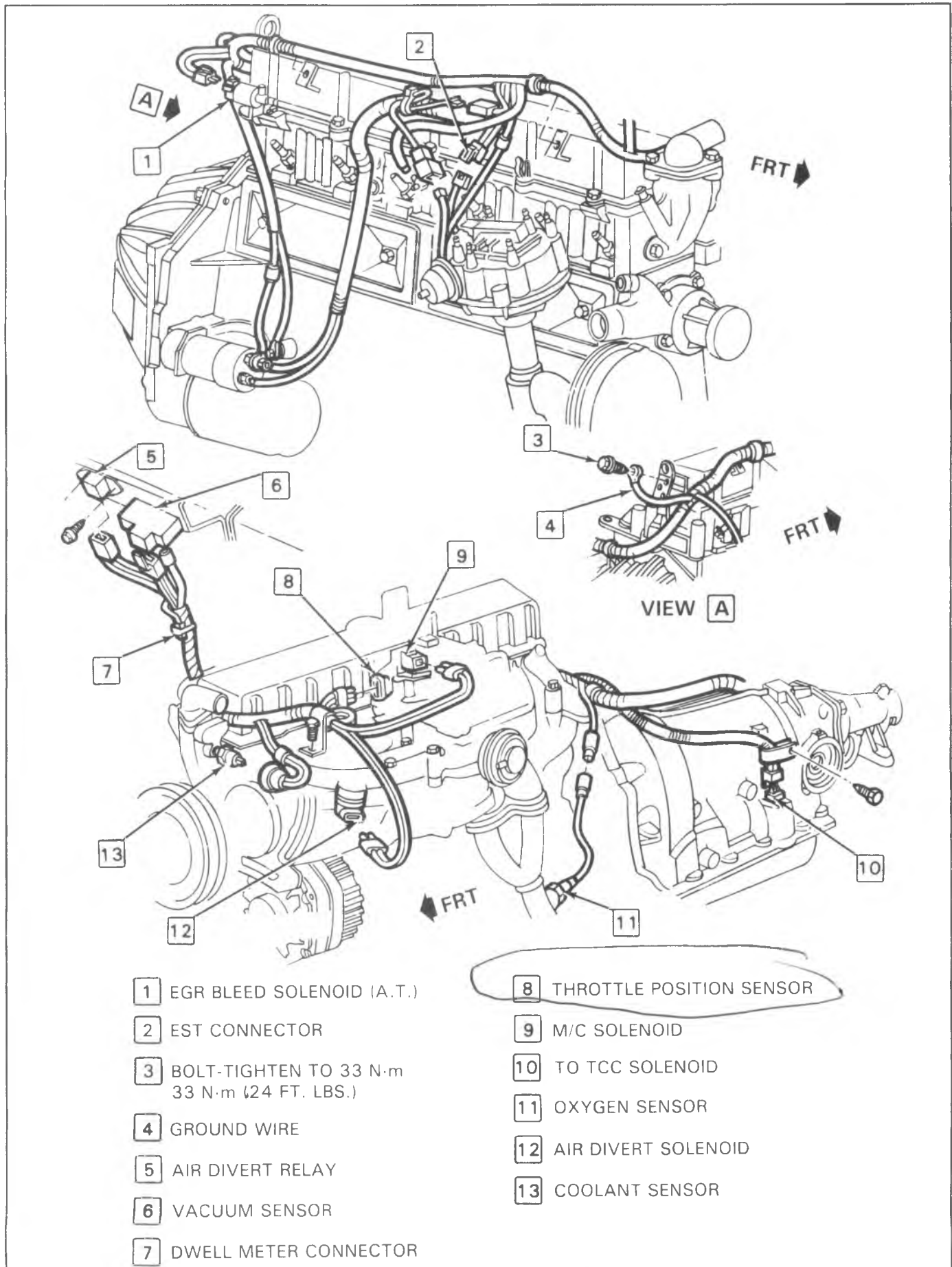

- 1 EGR BLEED SOLENOID (A.T.)
- 2 EST CONNECTOR
- 3 BOLT-TIGHTEN TO 33 N·m  
33 N·m (24 FT. LBS.)
- 4 GROUND WIRE
- 5 AIR DIVERT RELAY
- 6 VACUUM SENSOR
- 7 DWELL METER CONNECTOR

- 8 THROTTLE POSITION SENSOR
- 9 M/C SOLENOID
- 10 TO TCC SOLENOID
- 11 OXYGEN SENSOR
- 12 AIR DIVERT SOLENOID
- 13 COOLANT SENSOR

Fig. 6E1-56--Component Location - 4.1L Engine (G Series)

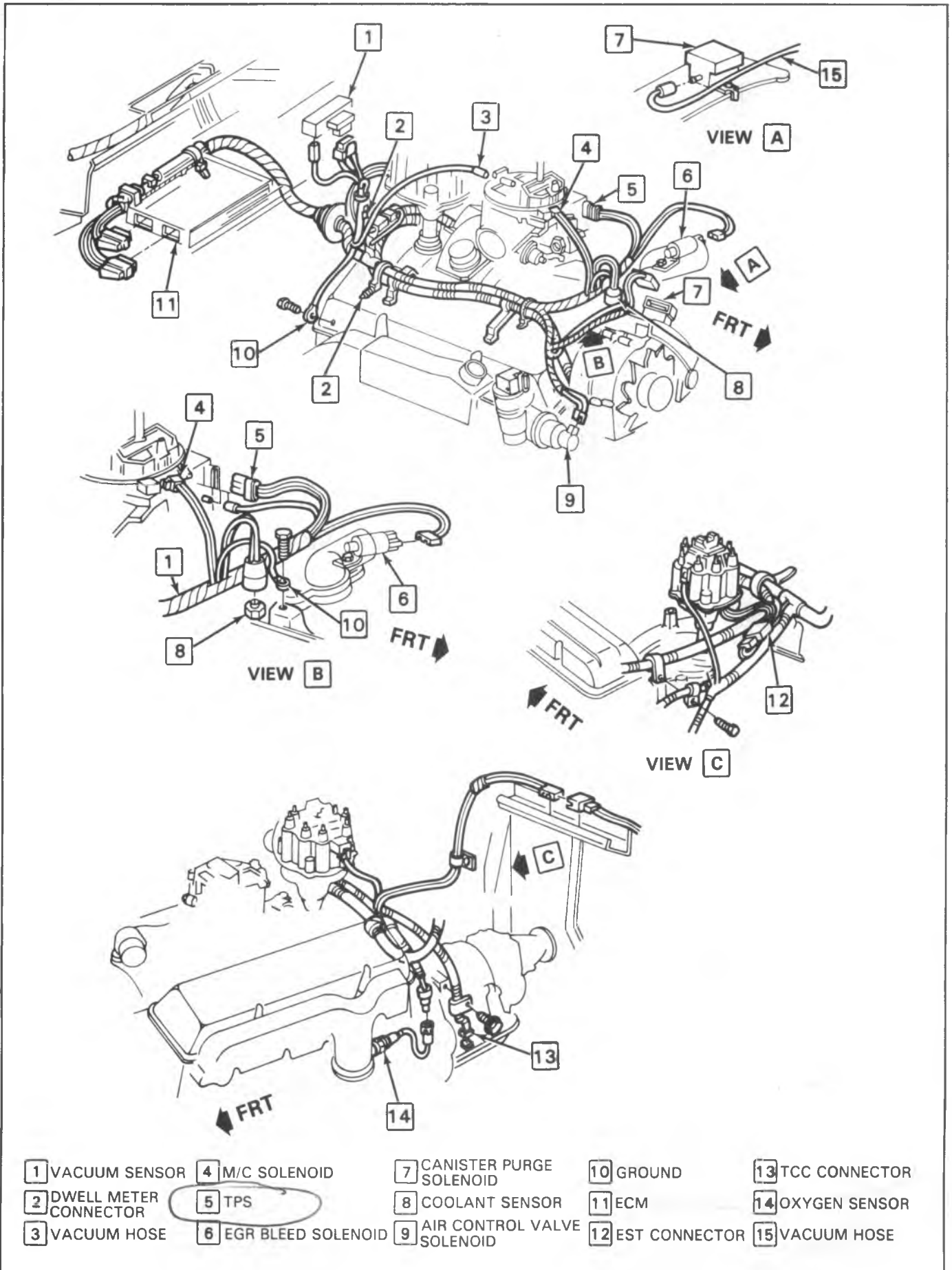
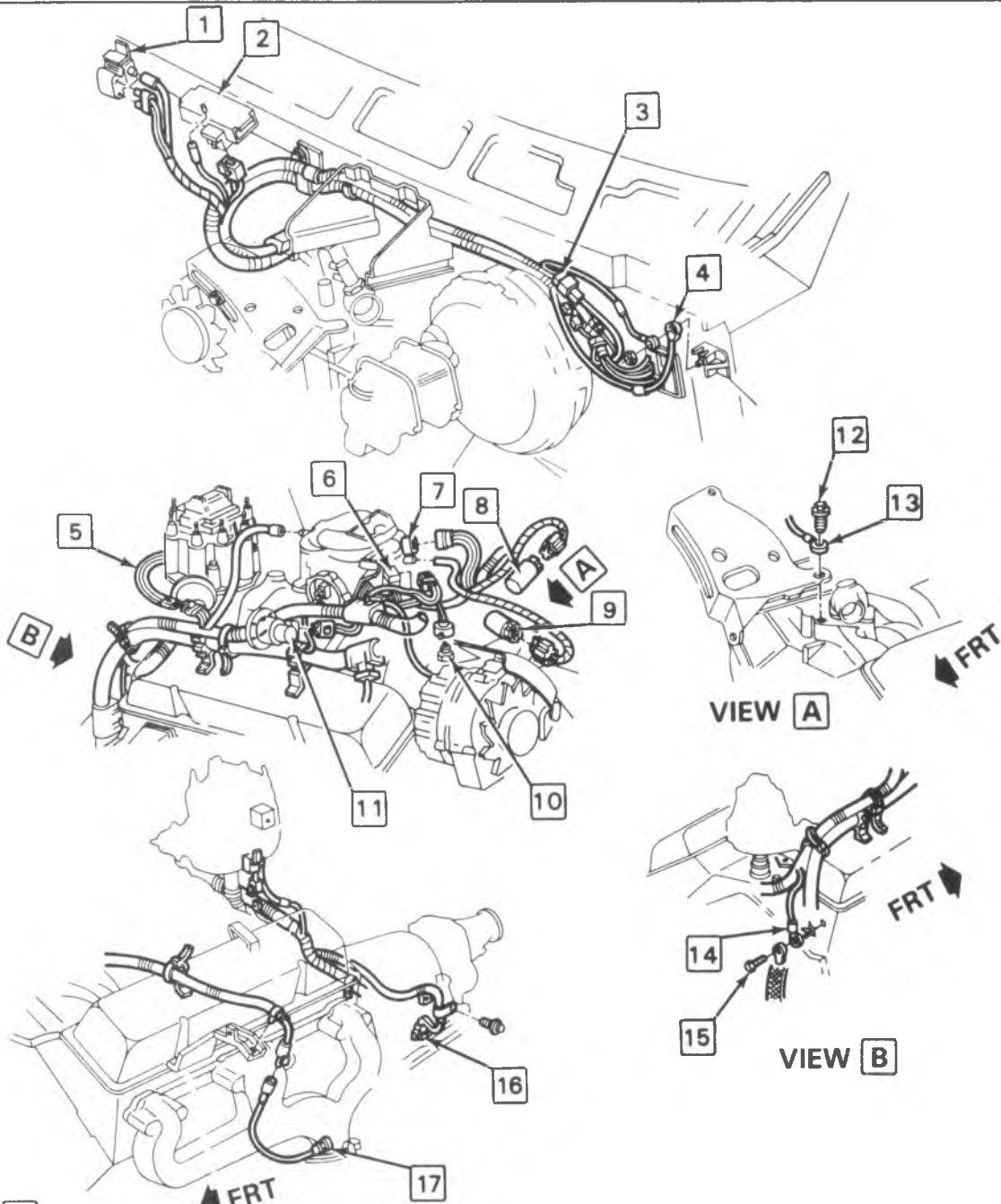

Fig. 6E1-57--Component Location - 5.0L/5.7L Engine (CK Series)



- |                                    |                         |
|------------------------------------|-------------------------|
| 1 SOLENOID                         | 10 COOLANT SENSOR       |
| 2 VACUUM SENSOR                    | 11 AIR DIVERT SOLENOID  |
| 3 DWELL METER CONNECTOR            | 12 BOLT                 |
| 4 SYSTEM GROUND WIRE               | 13 GROUND-OXYGEN SENSOR |
| 5 EST CONNECTOR                    | 14 SYSTEM GROUND        |
| 6 M/C SOLENOID                     | 15 BOLT                 |
| 7 THROTTLE POSITION SENSOR         | 16 TO TCC SOLENOID      |
| 8 EGR BLEED SOLENOID (WITHOUT A/C) | 17 OXYGEN SENSOR        |
| 9 EGR BLEED SOLENOID (WITH A/C)    |                         |

Fig. 6E1-58--Component Location-5.0L/5.7L Engine (G Series)



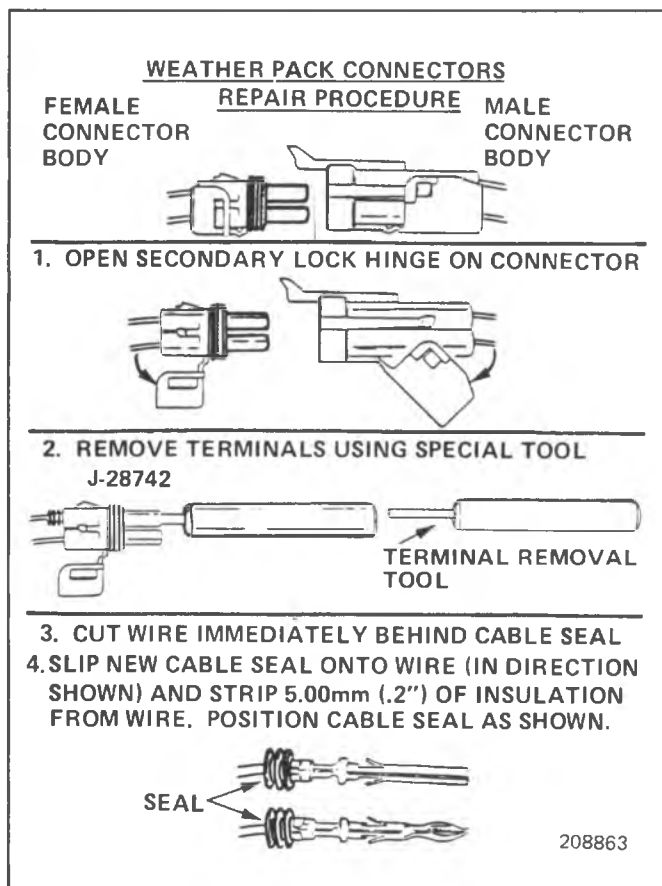

Fig. 6E1-59--Weather-Pack Terminals

## COOLANT SENSOR

(Figs. 6E1-55 thru 58)

### Functional Check

With sensor probe (Coolant Sensor Tip) at 15°C (59°F), the resistance across the terminals should be 4114-4743 ohms.

### Removal

1. Disconnect electrical connection at temperature switch.
2. Back out threaded temperature switch.

### Installation

1. Carefully replace temperature switch and tighten to 7 N·m (72 in. lb.).
2. Connect electrical connector to switch.

## WIRING HARNESS AND CONNECTORS

### Description

The wiring harness electrically connects the ECM to the various switches and sensors within the system. The wiring is an additional harness in the engine compartment and connects to the ECM located inside the car in the instrument panel area.

There are many components required for the system. This includes new terminals, connectors, cables, and seals.

All of the connectors will have positive locks and secondary terminal locks.

All system connections in the engine compartment are environmentally protected. The reasons for using this type of connections are low voltage and current levels, and the environment to which the connectors are exposed. In many cases in the System, the voltage is limited to 5V and, for the Oxygen Sensor, as low as 500 MV and, in nearly all cases, the current is below 250 MA.

Environmental protection features of the connector design protect the terminals from the engine compartment environment. This is especially important when the voltage and current levels are too low to break down oxidation and deposits on the terminals.

### WIRING HARNESS SERVICE AND REPAIR

The special connectors used in the wiring harness are known as Weather-Pack connectors. Fig. 6E1-59 shows a Weather-Pack terminal and the special tool (J-28742) is required to service it. This special tool is required to remove the pin and sleeve terminals. If removal is attempted with an ordinary pick, there is a good chance that the terminal will be bent or deformed. And, unlike standard blade-type terminals, these terminals cannot be straightened once they are bent.

Make certain that the connectors are properly seated and all of the sealing rings in place when connecting leads. The hinge-type flap provides a backup, or secondary locking feature for the terminals. They are used to improve the connector reliability by retaining the terminals if the small terminal lock tangs are not positioned properly.

Molded-on connectors require complete replacement of the connection. This means splicing a new connector assembly into the harness. Environmental connections cannot be replaced with standard connections. Instructions are provided with Weather-Pack connector and terminal packages.

Engine compartment harnesses should be replaced with proper part number harnesses. When single wires are spliced into a harness, use wire with high temperature insulation only.

With the low current and voltage levels found in the System, it is important that the best possible bond at all wire splices be made by soldering the splices as shown in Fig. 6E1-60.

Use care when probing the connections or replacing terminals in them, it is possible to short between opposite terminals. If this happens to the wrong terminal pair, it is possible that damage may be done to certain components. Always use jumper wires between connectors for circuit checking. Never probe through the Weather-Pack seals.

When diagnosing the System, open circuits are often difficult to locate by sight because oxidation or terminal misalignment are hidden by the connectors. Merely wiggling a connector on a sensor or in the wiring harness may correct the open circuit condition. This should always be considered when an open circuit or failed sensor is indicated while trouble-shooting the "System". Intermittent problems may also be caused by oxidized or loose connectors.



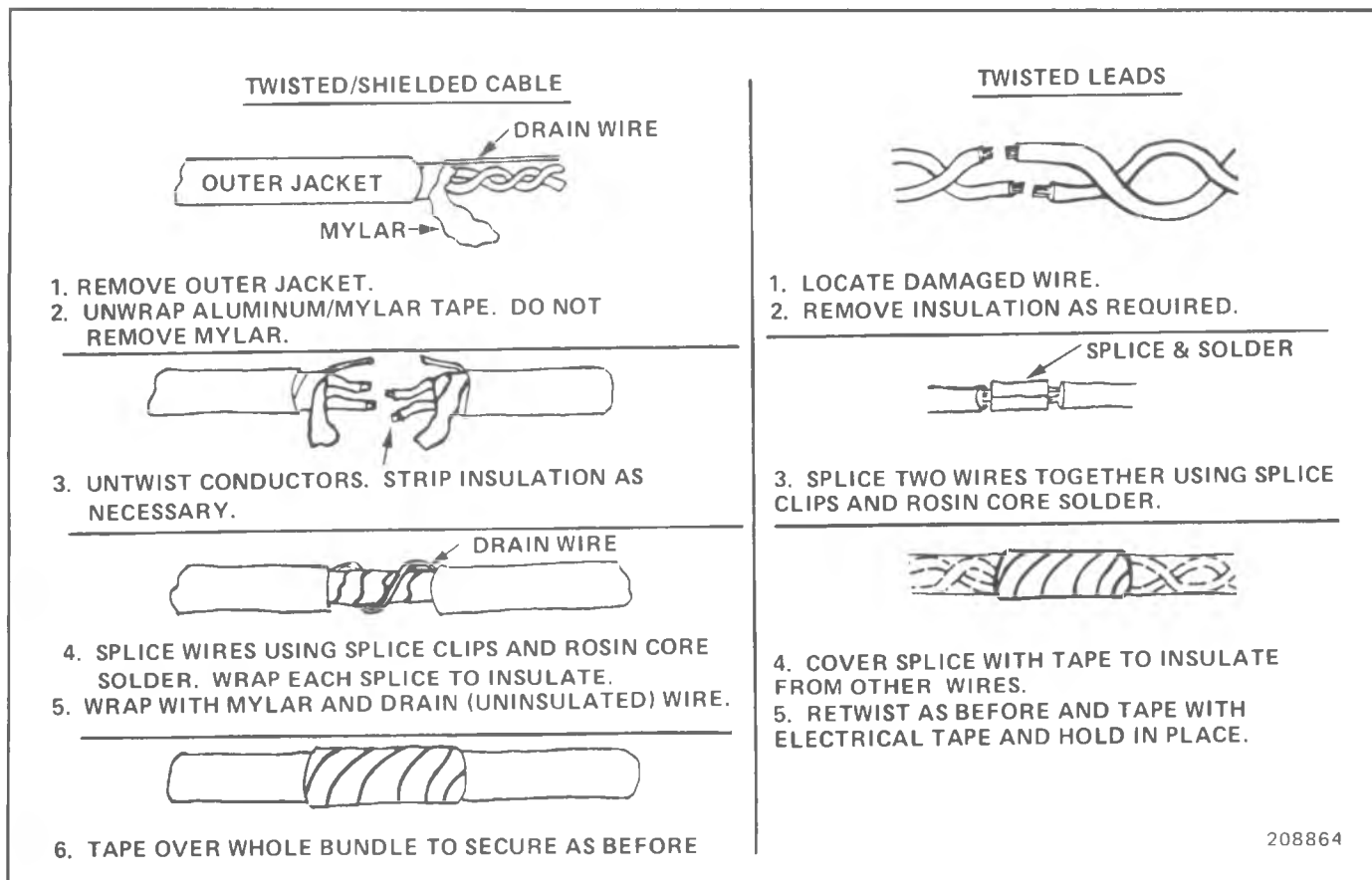

Fig. 6E1-60--Wiring Repair

## FUEL CONTROL SYSTEM

### GENERAL

The fuel flow through the carburetor idle main metering circuits is controlled by a mixture control (M/C) solenoid. The M/C solenoid is controlled by the Electronic Control Module (ECM) which provides a ground for the solenoid. The M/C solenoid changes the air/fuel mixture to the engine by allowing more or less fuel to flow through the carburetor. When the solenoid is energized, the fuel flow through the carburetor is reduced, providing a leaner fuel mixture. When the ECM removes the ground path, the solenoid de-energizes and allows more fuel flow and thus a richer mixture.

### Fuel Control Monitor

The ECM determines the proper fuel mixture by monitoring the signal sent by an oxygen sensor, located in the exhaust stream. When the mixture is lean, the oxygen sensor voltage is low and the ECM commands a richer mixture. When the mixture is rich, the oxygen sensor voltage is higher and the ECM commands a leaner mixture.

The rich-to-lean and lean-to-rich action can be monitored with the dwellmeter. The dwellmeter should be set on the 6-cylinder position, regardless of the engine being tested. It is connected to the M/C solenoid "dwell" lead (a green connector located near the M/C solenoid in the harness). While the dwellmeter is connected, do not allow the terminal to touch ground. This includes hoses, as they are conductive. On a normal operating engine, the dwell

reading at just above idle and part throttle should read between 10° and 50° and will be varying. "Varying" means the needle continually moves up and down the scale. The amount it moves does not matter, only the fact that it does move. This is called "CLOSED LOOP" operation. This means the dwell reading is being varied by the ECM.

Under certain engine operating conditions, such as idle, wide-open throttle (WOT), or when the engine or oxygen sensor is cold, the dwell reading will not vary. This is called "OPEN LOOP" operation. This means the oxygen sensor signal has no effect on the dwell. If there is a question whether the system is in closed loop, richening or leaning the mixture (by choking the carburetor or inducing an air leak) will cause the dwell to change if the system is in closed loop.

Fig. 6E1-61 reflects typical M/C Solenoid operation under various engine operating conditions.

### Oxygen Sensor (Fig. 6E1-62)

The Oxygen Sensor protrudes into the exhaust stream and monitors the oxygen content of the exhaust gases. The difference between the oxygen content in the exhaust gases and that of the outside air generates a voltage signal to the ECM. The ECM monitors this voltage and, depending on the value of the received signal, the ECM issues commands to the M/C Solenoid to adjust for rich or lean conditions.

The proper operation of the Oxygen Sensor depends upon four primary conditions:

1. Good electrical connections - the low voltages and

| ENGINE CONDITION   | FUEL CONTROL SYSTEM OPERATION   |  | DWELLMETER READING   |
|--|---|--|--|
|  | INPUTS TO ECM   | M/C SOLENOID OPERATION   |  |
| STARTING (CRANKING)  | <ul style="list-style-type: none"> <li>TACHOMETER LESS THAN 200 RPM</li> </ul>  | M/C SOLENOID OFF (RICH MIXTURE)  | 0°   |
| WARM-UP  | <ul style="list-style-type: none"> <li>TACH ABOVE 200 RPM (ENGINE RUNNING)</li> <li>O<sub>2</sub> SENSOR LESS THAN 315° C (600° F)</li> <li>COOLANT LESS THAN 19° C (66° F)</li> <li>LESS THAN 10 SECONDS ELAPSED SINCE STARTING</li> </ul> | FIXED COMMAND FROM ECM TO M/C SOLENOID   | FIXED READING BETWEEN 10° AND 50°  |
| WARM OPERATION IDLE AND CRUISING ("CONSTANT" ENGINE SPEED) | <ul style="list-style-type: none"> <li>O<sub>2</sub> SENSOR ABOVE 315° C (600° F)</li> <li>COOLANT ABOVE 19° C (66° F)</li> <li>MAP SENSOR</li> </ul>   | M/C SOLENOID SIGNAL DETERMINED BY OXYGEN SENSOR INFORMATION TO ECM   | VARYING ANYWHERE BETWEEN 10° AND 50° (NOMINAL 35°) (FASTER WITH HIGHER RPM)  |
| ACCELERATION AND DECELERATION ("CHANGING" ENGINE SPEEDS)   | <ul style="list-style-type: none"> <li>THROTTLE POSITION SENSOR (TPS)</li> <li>MAP SENSOR</li> <li>O<sub>2</sub> SENSOR</li> </ul>  | MOMENTARY PROGRAMMED SIGNAL FROM ECM DURING PERIOD AFTER THROTTLE CHANGE UNTIL OXYGEN SENSOR RESUMES CONTROL OF M/C SOLENOID | MOMENTARY CHANGE, CAN'T BE READ ON DWELLMETER. WILL BE VARYING, BUT HIGH OR LOW ON SCALE DEPENDING UPON OPERATING CONDITION(S) |
| WIDE-OPEN THROTTLE   | <ul style="list-style-type: none"> <li>TPS FULLY OPEN</li> <li>MAP SENSOR</li> </ul>  | VERY RICH COMMAND TO M/C SOLENOID  | 6°   |

208857

Fig. 6E1-61--Fuel Control System Modes

- low currents generated by the Oxygen Sensor depends upon good, clean connections.
- 2. Outside air supply - the oxygen sensor is designed to allow air circulation to the internal portion of the sensor. When servicing the sensor, do not plug or restrict the air passages.
- 3. Proper operating temperature - the ECM will not recognize the sensor signal until the sensor reaches approximately 360°C (600°F).
- 4. Non-lead fuel - the use of non-lead fuel is

essential to the proper operation of the sensor.

**NOTICE:** No attempt should be made to measure the Oxygen Sensor output voltage. The current drain of any conventional voltmeter would be enough to permanently damage the sensor. No jumpers, test leads, or other electrical connections should ever be made to the sensor. Use these tools only on the ECM side of the harness connector AFTER DISCONNECTION from the sensor.

**Throttle Position Sensor (Fig. 6E1-63)**

The Throttle Position Sensor (TPS) located in the carburetor body and is operated by the accelerator pump lever. The sensor operates similar to a fuel tank sending unit, electrically signaling any change in position, thereby informing the ECM of throttle position. Refer to the Carburetor Section 6C1 (E4ME) or 6C3 (E2SE) for service information and adjustment procedures.

**Mixture Control (M/C) Solenoid**

The air/fuel ratio of the carburetor is controlled by an electrically operated solenoid which operates dual metering rods in the float bowl. The metering rod supplement the fuel supplied to the idle and main systems, varying the air/fuel ratio within a pre-calibrated range. The M/C Solenoid additionally controls the air/fuel ratio through the use of an idle air bleed circuit that operates in conjunction with the metering rods.

The metering system control (Fig. 6E1-64) is achieved by varying the fuel flow restriction. The de-energized solenoid allows a richer air/fuel mixture while an energized

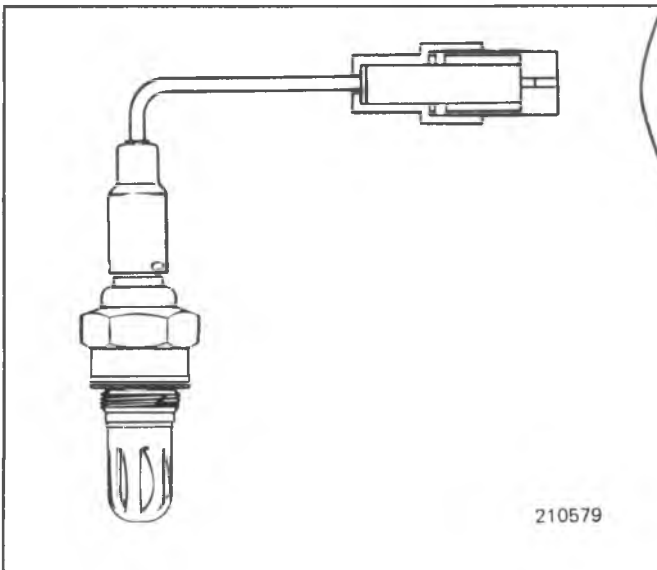

210579

Fig. 6E1-62--Oxygen Sensor

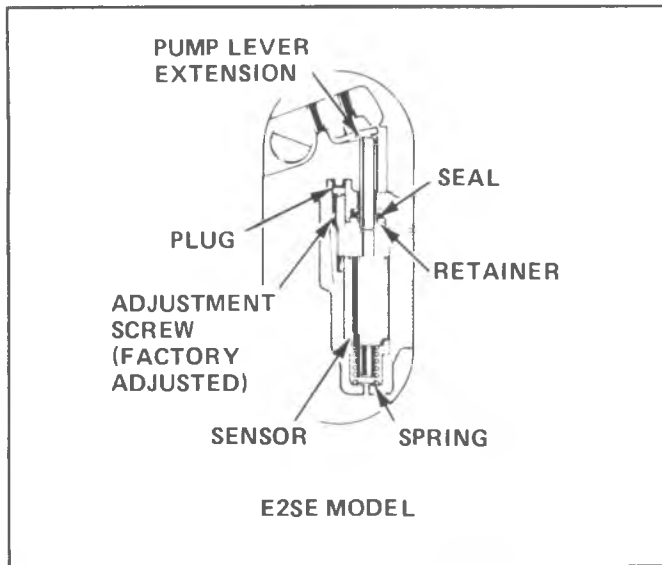

Fig. 6E1-63--Throttle Position Sensor

solenoid allows a leaner air/fuel mixture. The solenoid cycles ON/OFF 10 times per second and air/fuel ratio control depends upon amount of time the solenoid is de-energized versus the amount of time spent energized (M/C Solenoid dwell signal).

Refer to Carburetor Section 6C1 (E4ME) or 6C3 (E2ME) for service information and adjustment procedures.

## DIAGNOSIS

Refer to the Computer Command Control system in this section for diagnosis of fuel control system when a trouble code appears at the "check engine" light.

## ON-VEHICLE SERVICE

### Mixture Control Solenoid

This solenoid is located in the carburetor assembly. Service procedures for this solenoid can be found in the E2ME or E4ME carburetor section.

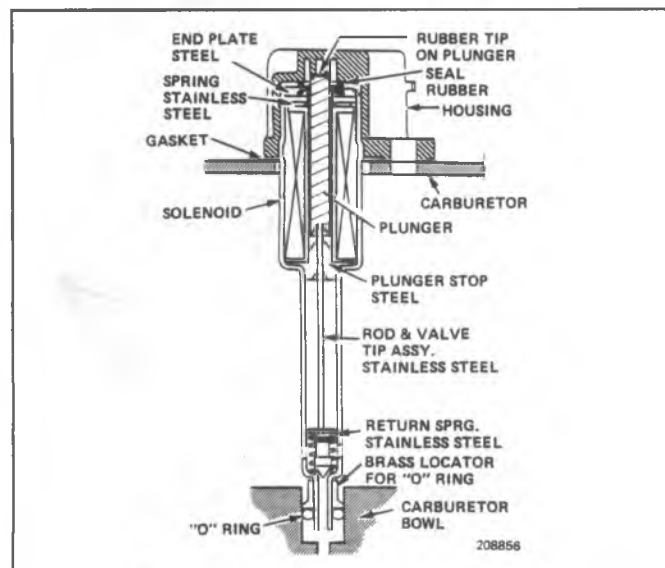

Fig. 6E1-65--M/C Solenoid-Model E2SE

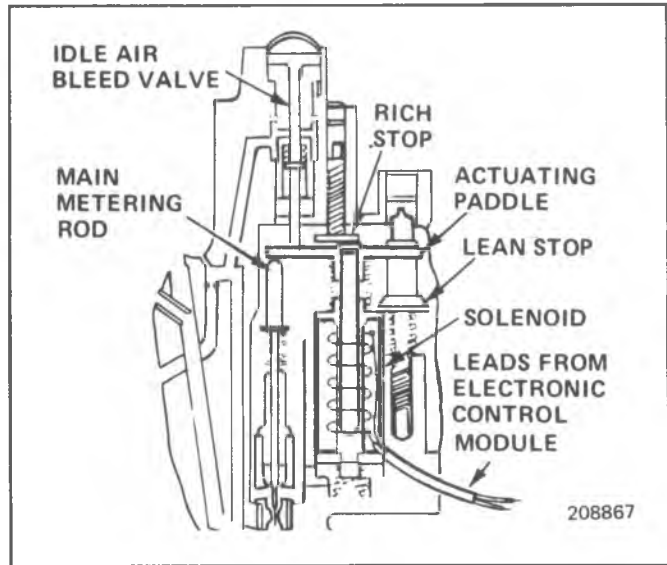

Fig. 6E1-64--M/C Solenoid-Model E4ME

## Throttle Position Sensor

The throttle position sensor is located in the carburetor assembly. Service procedures for this sensor can be found in the E2SE or E4ME Carburetor Section.

## Oxygen Sensor

(Fig. 6E1-66)

Oxygen sensor uses a permanently attached pig-tail and connector. This pig-tail should not be removed from the oxygen sensor. Damage or removal of pig-tail or connector could affect proper operation of the oxygen sensor.

Care must be taken when handling an oxygen sensor in order to preserve the efficiency. The in-line electrical connector and louvered end must be kept free of grease or other contaminants. Do not use cleaning solvents of any type.

### Removal

Oxygen sensor may be difficult to remove when engine temperature is below 48°C (120°F). Excessive force may damage threads in exhaust manifold or exhaust pipe.

1. Disconnect electrical connector and any attaching hardware.
2. Remove oxygen sensor.

### Installation

It is important that care be taken when installing oxygen sensor so that the silicone boot is in the correct position to insure operation and to avoid melting the boot.

1. A new oxygen sensor is pre-coated with anti-seize compound, but if same oxygen sensor is being installed, coat threads of oxygen sensor with anti-seize compound P/N 5613695 (or equivalent).
2. Install sensor and torque to 41 N·m (30 ft. lbs.).
3. Connect electrical connector and attaching hardware if used.

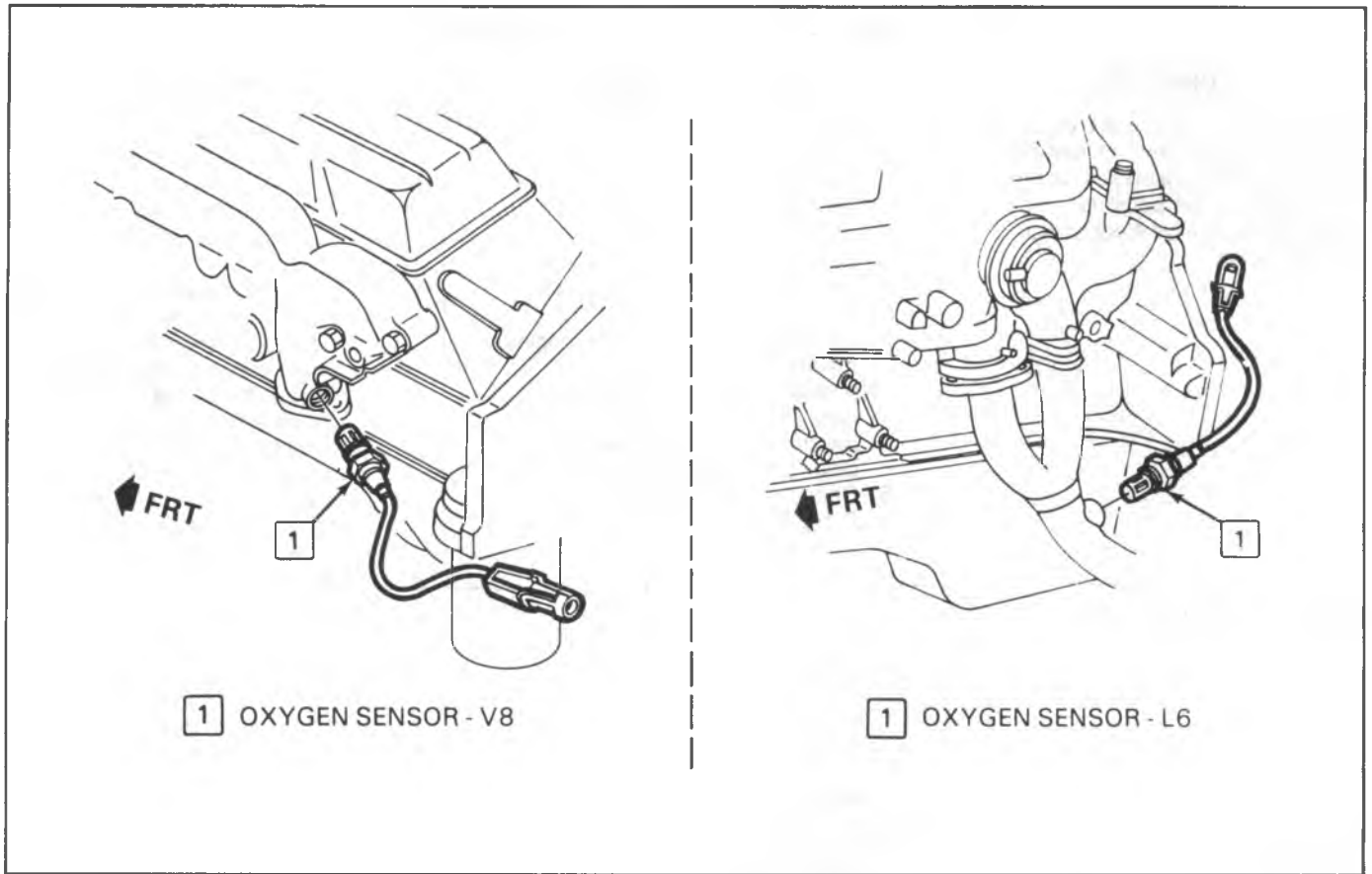

Fig. 6E1-66--Oxygen Sensor Installation

## AIR INJECTION REACTION(AIR) SYSTEM

### GENERAL

An air injection reactor (AIR) (Fig. 6E-4) is used on some engines to provide additional oxygen to continue the combustion process after the exhaust gases leave the combustion chamber. A belt driven air pump provides pressurized air which is injected into the exhaust port of the cylinder head or exhaust pipe and then into the exhaust system. The AIR system operates at all times and will bypass air only for a short duration of time during deceleration and at high speeds. A diverter valve performs a bypass function, and the check valve protects the air pump from damage by preventing a back flow of exhaust gas.

### DIAGNOSIS

Refer to Figure 6E1-67 for Air Injection Reactor System Diagnosis.

Refer to Figures 6E1-68 and 69 for Air Injector Reactor Check on California vehicles with Computer Command Control.

### ON-VEHICLE SERVICE

#### Functional Test

See "AIR Diverter Valve Check" in this section.

#### Drive Belt

#### Inspection

1. Inspect drive belt for wear, cracks or deterioration and replace if necessary.

2. Inspect belt tension and adjust if below 70 lbs. using a belt tension gage (Tool J-23600 or BT 33-73F).

### Adjustment

Loosen pump mounting bolt and pump adjustment bracket bolt. Move pump until belt is properly tensioned then tighten adjustment bracket bolt and mounting bolt. Use a belt tension gage to check adjustment (Fig. 6E1-70).

**NOTICE:** Do not pry on the pump housing. Distortion of the housing will result in extensive damage to the Air Injection Pump.

### Replace

1. Loosen pump mounting bolt and pump adjustment bracket bolt, then swing pump until drive belt may be removed.
2. Install a new drive belt and adjust as outlined above.

### Pump Pulley

#### Remove

1. Hold pump pulley from turning by compressing drive belt, then loosen pump pulley bolts.
2. Remove drive belt as outlined above, then remove pump pulley.

## DIAGNOSIS — BELT DRIVEN AIR PUMP SYSTEM

| CONDITION   | POSSIBLE CAUSE  | CORRECTION   |
|---|---|--|
| No air supply — accelerate engine to 1500 rpm and observe air flow from hoses. If the flow increases as the rpm's increase, the pump is functioning normally. If not, check possible cause. | <ol style="list-style-type: none"> <li>1. Loose drive belt.</li> <li>2. Leaks in supply hose.</li> <li>3. Leak at fittings.</li> <li>4. Air expelled through by-pass valve.</li> <li>4a. Connect a vacuum line directly from engine manifold to by-pass valve.</li> <li>4b. Connect vacuum line from engine manifold vacuum source to by-pass valve through vacuum differential valve directly, by passing the differential vacuum delay and separator valve.</li> <li>5. Check valve inoperative.</li> <li>6. Pump failure.</li> </ol> | <ol style="list-style-type: none"> <li>1. Tighten to specifications.</li> <li>2. Locate leak and repair.</li> <li>3. Tighten or replace clamps.</li> <li>4a. If this corrects the problem go to step b. If not, replace air by-pass valve.</li> <li>4b. If this corrects the problem, check differential vacuum, delay and separator valve and vacuum source line for plugging. Replace as required. If it doesn't, replace vacuum differential valve.</li> <li>5. Disconnect hose and blow through hose toward check valve. If air passes, function is normal. If air can be sucked from check valve, replace check valve.</li> <li>6. Replace pump.</li> </ol> |
| Excessive pump noise, chirping, rumbling, knocking.   | <ol style="list-style-type: none"> <li>1. Leak in hose.</li> <li>2. Loose hose.</li> <li>3. Hose touching other engine parts.</li> <li>4. Pump mounting fasteners loose.</li> <li>5. Pump failure.</li> <li>6. Check valve inoperative.</li> </ol>  | <ol style="list-style-type: none"> <li>1. Locate source of leak using soap solution and correct.</li> <li>2. Reassemble and replace or tighten hose clamp.</li> <li>3. Adjust hose position.</li> <li>4. Tighten mounting screws as specified.</li> <li>5. Replace pump.</li> <li>6. Replace check valve.</li> </ol>   |
| Excessive belt noise.   | <ol style="list-style-type: none"> <li>1. Loose belt.</li> <li>2. Seized pump.</li> </ol>   | <ol style="list-style-type: none"> <li>1. Tighten to spec.</li> <li>2. Inspect pump.</li> </ol>  |
| Centrifugal filter fan damaged or broken.   | <ol style="list-style-type: none"> <li>1. Mechanical damage.</li> </ol>   | <ol style="list-style-type: none"> <li>1. Replace centrifugal filter fan.</li> </ol>   |
| Poor idle or driveability.  | <ol style="list-style-type: none"> <li>1. A defective A.I.R. system cannot cause poor idle or driveability.</li> </ol>  | <ol style="list-style-type: none"> <li>1. Do not replace A.I.R. system.</li> </ol>   |

Fig. 6E1-67 -- Air Management Diagnosis

**1983 CCC  
DIVERT VALVE CHECK**

2.8L S/T Truck M.T. 4.1L CKG Truck M.T. and "Cab Chassis" A.T. (A.T. in drive, parking brake set and drive wheels blocked.)\*

Check for at least 10" of vacuum at valve with engine idling.

Check for air to exhaust ports while system is in open loop after start-up, then divert to air cleaner when it goes closed loop.

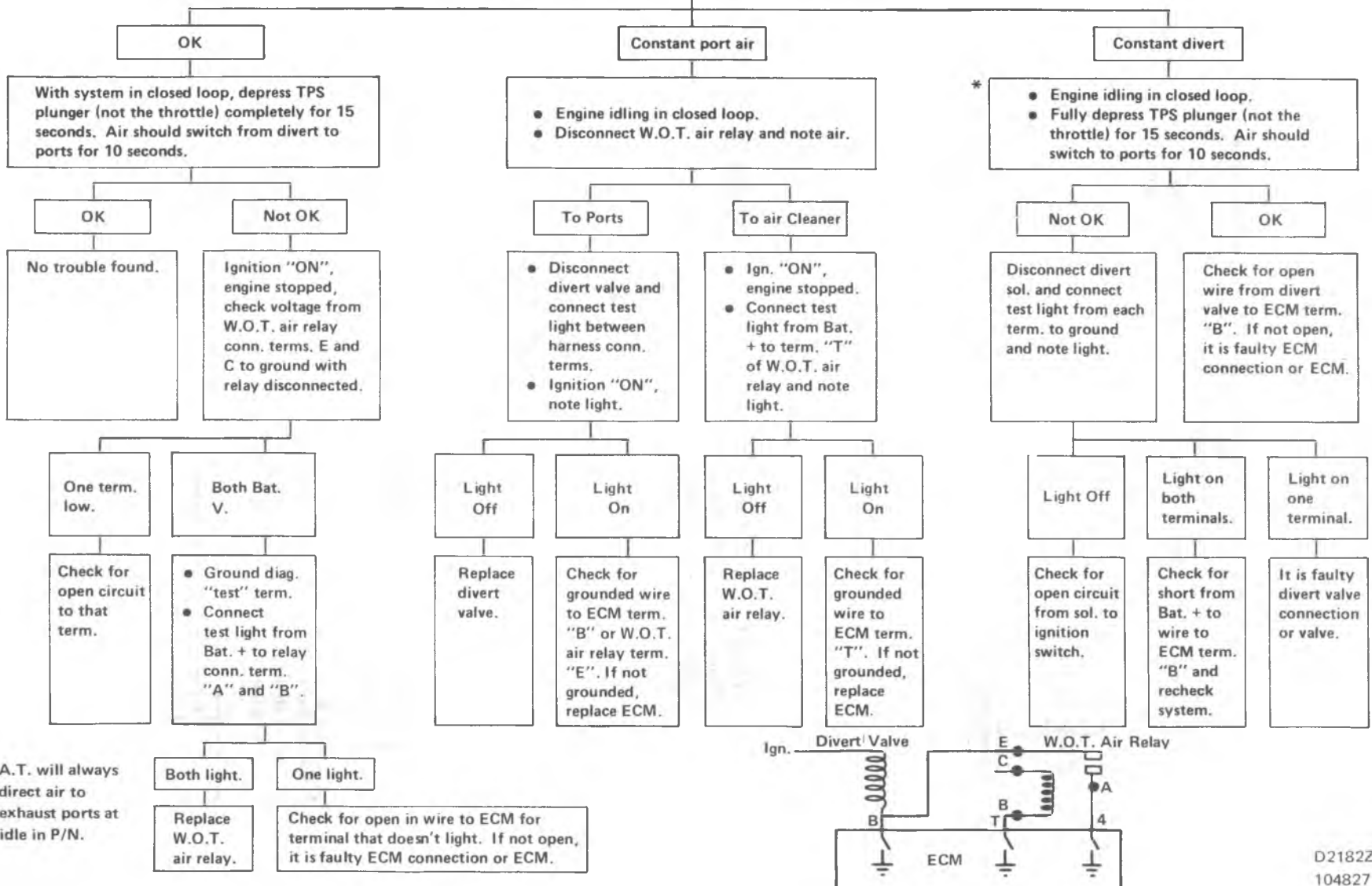

\*A.T. will always direct air to exhaust ports at idle in P/N.

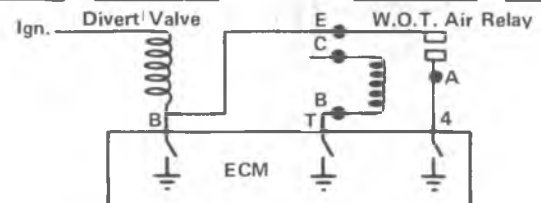

D2182Z  
104827

Fig. 6E1-68--Air Injection Reactor Check-4.1L M.T. (G Series)

1983 CCC  
ELECTRIC DIVERTER VALVE CHECK (EDV)

Check for at least 34 kPa (10") of vacuum at valve with engine idling.

- "Test" terminal ungrounded.
- Run engine at part throttle (under 2000 RPM).
- Air should go to exhaust ports until system goes closed loop, then divert to air cleaner.

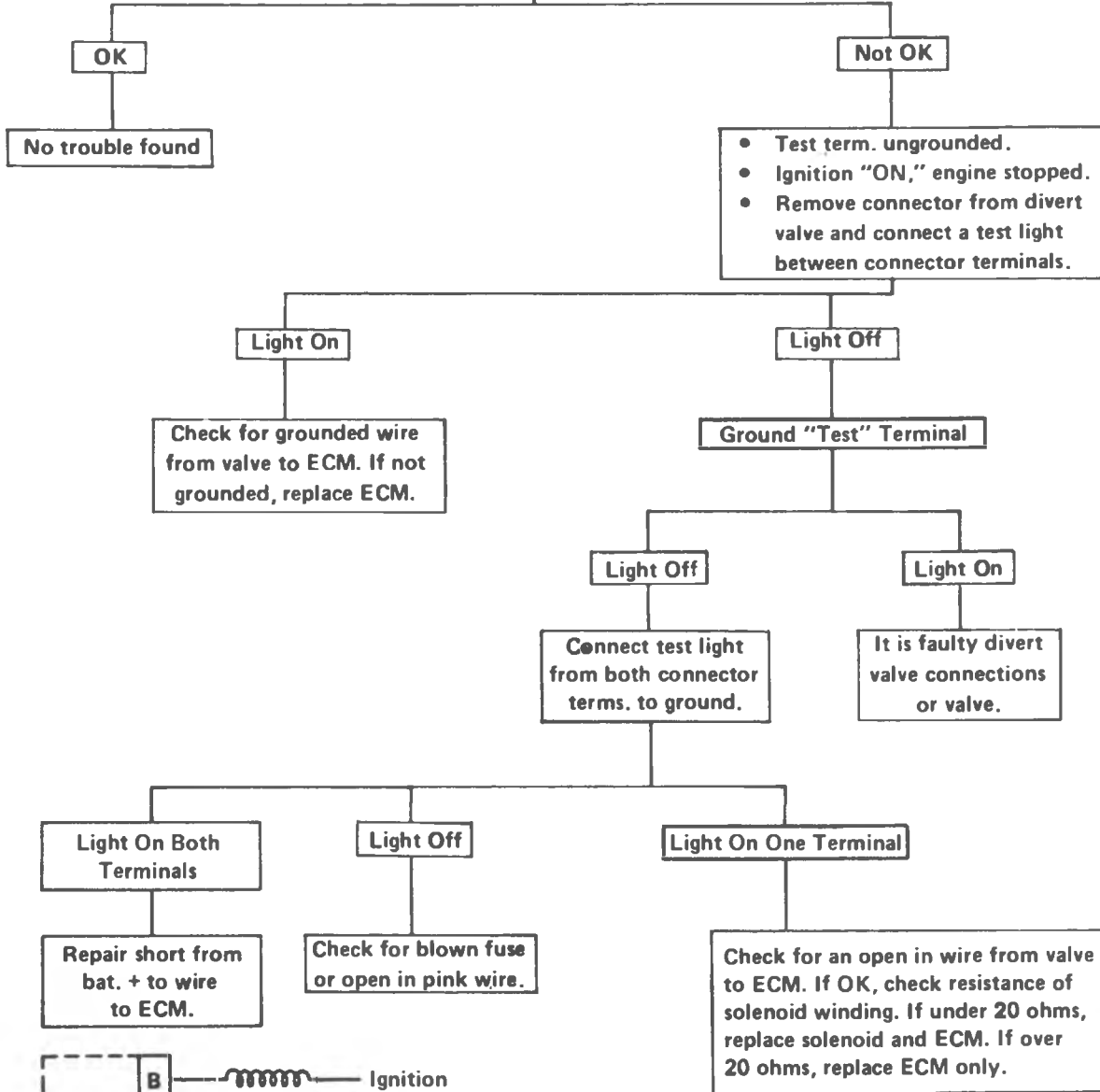

G1282Z  
104810

Fig. 6E1-69--Air Injection Reactor Check-All Except 4.1L M.T. (G Series)

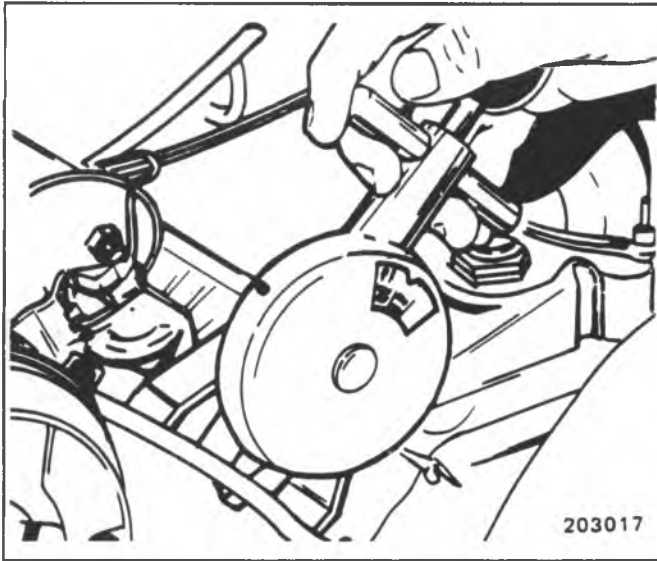

Fig. 6E1-70--Air Belt Tensioning

**Install**

1. Install pump pulley with retaining bolts hand tight. Install and adjust drive belt as outlined above.
2. Hold pump pulley from turning by compressing drive belt, then torque pump pulley bolts to 33 N·m (24 lb. ft.).
3. Recheck drive belt tension and adjust if required.

**Pump Filter****Remove**

1. Remove drive belt and pump pulley as previously outlined.
2. Insert needle-nose and pull fan from hub (Fig. 6E1-69). Care should be taken to prevent filter fragments from entering the air intake hole. Do not insert a screwdriver between pump and filter. It is seldom possible to remove the filter without destroying it. Do

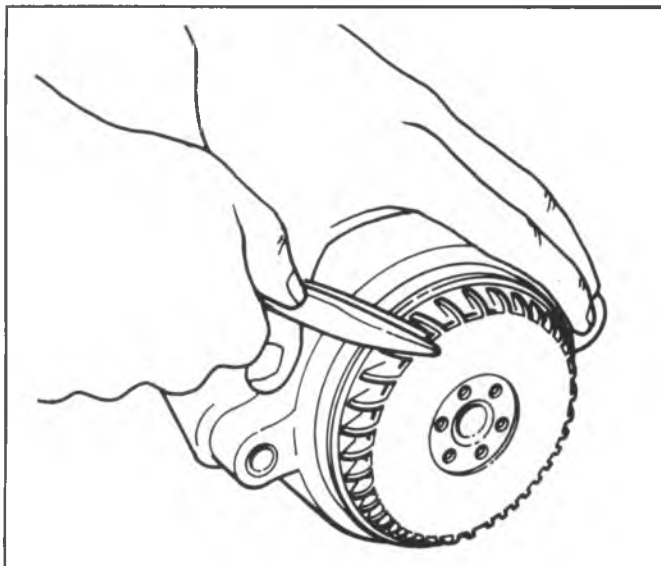

Fig. 6E1-71--Air Filter Removal

not attempt to remove the metal hub.

**Install**

1. Install the new filter by drawing it on with the pulley and pulley bolts. Do not attempt to install a filter by hammering it on or pressing it on.
2. Draw the filter down evenly by alternately torquing the bolts. Make certain that the outer edge of the filter slips into the housing. The slight amount of interference with the housing bore is normal.

The new filter may squeal upon initial operation until its O.D. sealing lip has worn in.

**AIR HOSES AND TUBES****Inspection**

1. Inspect all hoses for deterioration or leaks.
2. Inspect all tubes for cracks or leaks.
3. Check all hose and tube connections.
4. Make repairs or replace parts as needed.
5. Check all tube and hose routings. Interference may cause wear.
6. If leak is suspected on the pressure side of the system or any tubes and/or hoses have been disconnected on the pressure side, the connections should be checked for leaks with soapy water solution.
7. With the pump running, bubbles will form if a leak exists.

**Remove**

To replace any hose and/or tube, not routing, then remove hose(s) and/or tube(s) as required.

**Install**

1. Install new hose(s) and/or tube(s), routing them as when removed.
2. Tighten all connections.

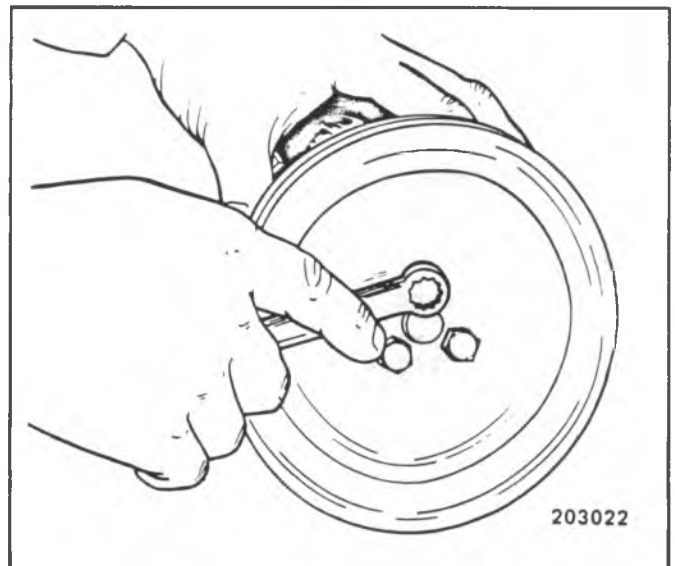

Fig. 6E1-72--AIR Filter Installation



**CHECK VALVE**

Refer to Figure 6E1-72 for Location

**Inspection**

1. The check valve should be inspected whenever the hose is disconnected from the check valve or whenever check valve failure is suspected. (A pump that had become inoperative and had shown indications of having exhaust gases in the pump would indicate check valve failure).
2. Remove check valve (See "Remove and Replace").
3. Blow through the check valve (toward the cylinder head), then reverse valve and attempt to blow back through check valve. Flow should only be in one direction (toward the exhaust manifold). Replace valve which does not function this way.

**Remove and Replace**

Disconnect pump outlet hose at check valve. Remove check valve from pipe assembly, being careful not to bend or twist the assembly.

Reverse above procedure to install new valve.

**AIR DIVERTER VALVE AND SILENCER ASSEMBLY (IF USED)**

Refer to Figures 6E1-67 through 69 for location and installation.

**Inspection**

1. Check condition and routing of all lines especially the signal line. All lines must be secure, without crimps and not leaking. Replace deteriorated lines.
2. Disconnect vacuum signal line at valve. Vacuum should be available with engine running.
3. Check valve attaching bolts for tightness.
4. Defective valves should be replaced (See Functional Test).

**Remove**

1. Remove carburetor air cleaner.
2. Disconnect vacuum signal line. Disconnect valve outlet hose(s) and electrical connection(s) (if used).
3. Remove bolts holding adapter to valve.
4. Remove valve from pump or adapter.

**Install**

1. Install valve to pump or adapter with new gasket.

2. Install outlet and vacuum signal hose(s), electrical connection(s) and check system for leaks and proper operation (See "Quick Checks", Air Management Operation Description).

**AIR PUMP**

Refer to Figures 6E1-67 through 69 for location.

**Inspection**

Accelerate warm engine to approximately 1500 rpm and observe air flow from hose (squeeze hose and feel for pulsations). If air flow increases as engine is accelerated, pump is operating satisfactorily. If air flow does not increase or is not present, proceed as follows:

1. Check for proper drive belt tension.
2. Check for a leaky pressure relief valve. Air may be felt flowing from the hose to the air cleaner (divert hose) with the pump running.

The AIR system is not completely noiseless. Under normal conditions, noise rises in pitch as engine speed increases. To determine if excessive noise is the fault of the Air Injection Reactor System, operate the engine with the pump drive belt removed. If excessive noise does not exist with the belt removed, proceed as follows:

3. Check for a seized Air Injection Pump.  
**DO NOT OIL AIR PUMP.**
4. Check hoses, tubes and all connections for leaks and proper routing.
5. Check AIR injection pump for proper mounting and bolt torque.
6. Perform "Air Systems Check".
7. Repair or replace components as necessary.

**Remove**

1. Remove the Air Diverter Valve and/or adapter at the pump.
2. Remove pump pulley and belt as outlined.
3. Remove pump mounting bolts and remove pump.

**Install**

1. Install pump with mounting bolts loose.
2. Install pump pulley as outlined.
3. Install and adjust belt as outlined.
4. Reinstall the Air Diverter Valve and/or adapter at the pump.
5. Tighten mounting bolts to 27-56 N·m (20-35 lb. ft.).

**PULSE AIR INJECTION REACTOR SYSTEM-PAIR****GENERAL**

The Pulse Air Injection Reactor System consists of four pulse air check valves. The check valves are connected by tubes to the exhaust ports. The firing of the engine creates a pulsating flow of exhaust gases which are positive or negative pressure. A negative pressure at the pulse air valves results in the flow of fresh air into the exhaust system. If pressure is positive, the check valve is forced closed and no

exhaust gas will flow past the valve into the fresh air supply line.

**DIAGNOSIS****Inspection and Checking**

Inspect pulse air valves, pipes, grommets and hose for leaks and cracks and replace as required.

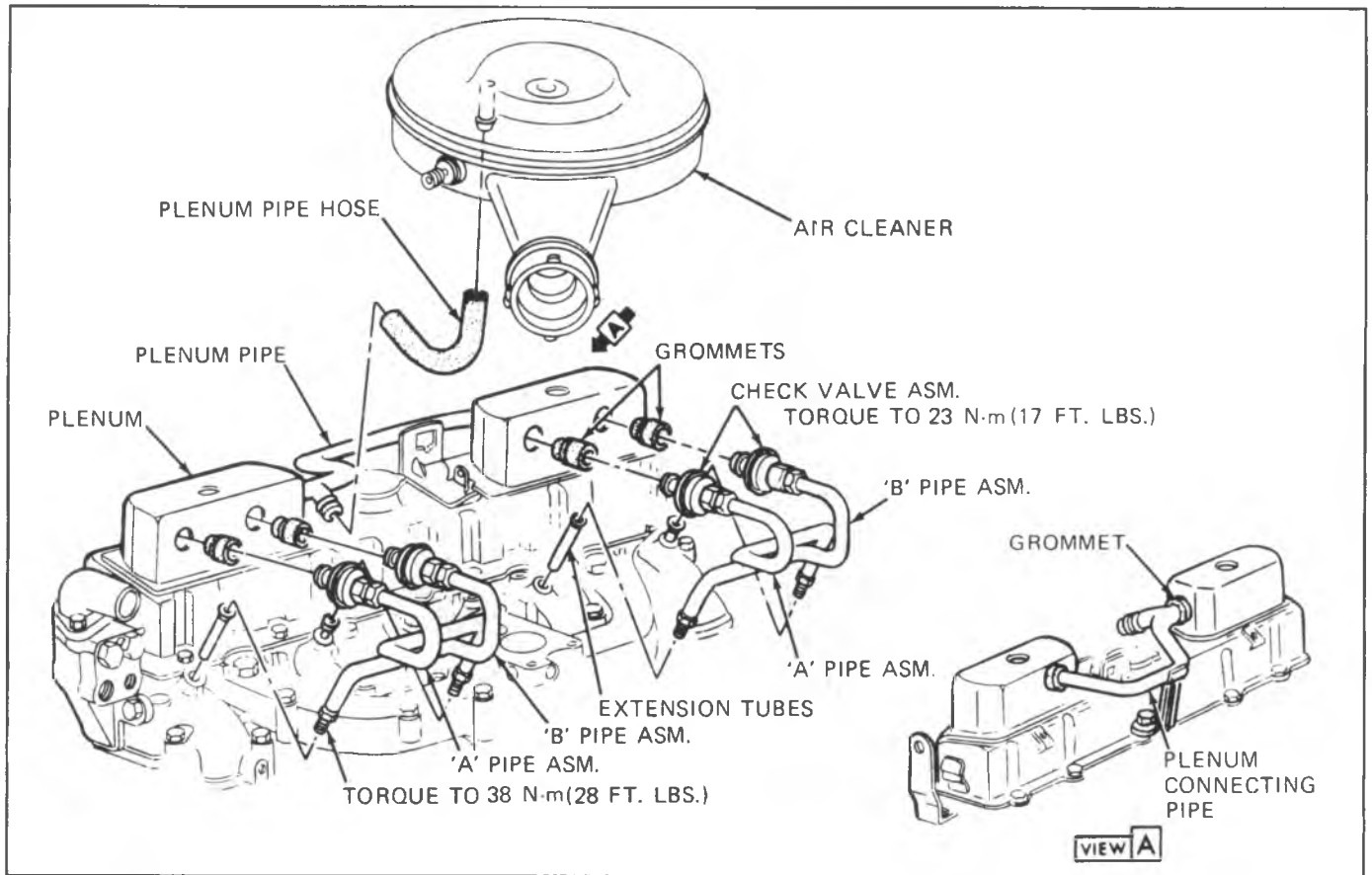

Fig. 6E1-73--PAIR System

Check operation of pulse air valves by creating a vacuum at grommet end of valve by adapting tool J-23738, with a tight fitting length of 3/4" hose. With vacuum of 5 kPa (17" Hg), there will be an allowable drop to 1.7 kPa (6" Hg.) in 2 seconds. Replace valve and/or hose if vacuum drops in less than two seconds.

**NOTICE:** Vacuum drop must be a result of a leaking valve not a leaking hose or connection.

## ON-VEHICLE SERVICE

### Replacement (Fig. 6E1-73)

1. Remove air cleaner and disconnect rubber hose from plenum connecting pipe.
2. Disconnect four pipe check valve fittings at cylinder head and remove check valve pipes from plenum grommets.
3. Disconnect check valve from check valve pipe.
4. Bench assemble check valves to check valve pipe.
5. Install pipe check valve assemblies to cylinder head as shown in Fig. 6E1-74 and finger tighten the fittings.
6. Using a 1" open end wrench or similar tool as a lever, align check valve on pipe A (Fig. 6E1-74) to the plenum grommet. Then using palm of your left hand, install check valve into the grommet. Use rubber lubricant on grommets to ease assembly.
7. Repeat procedure in Step 6 on pipe "B" (Fig. 6E1-75) but use your left hand on the tool for alignment of check valve and install valve with the palm of your right hand.
8. Tighten fittings to specified torque and reinstall air cleaner and hose.

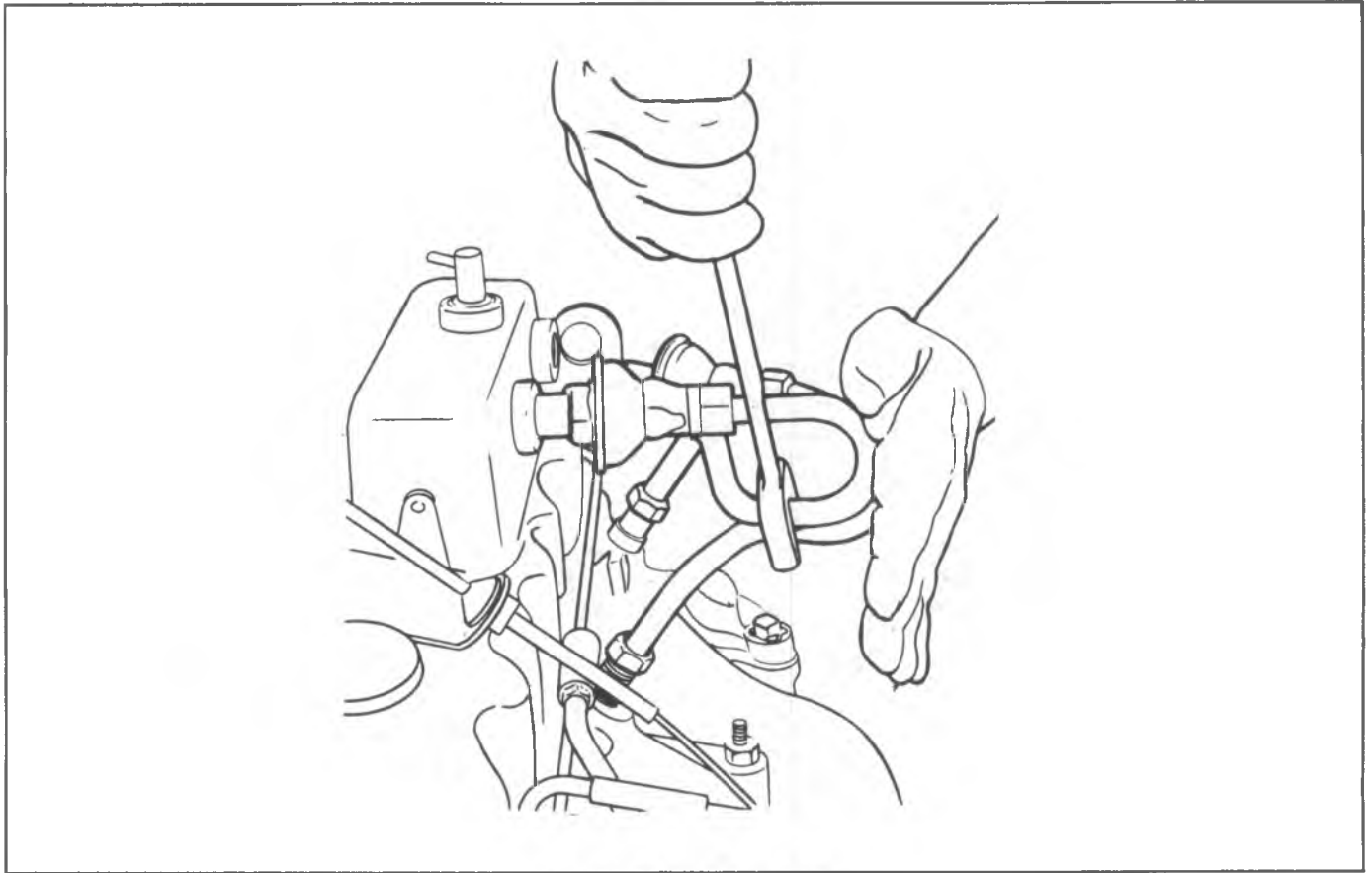

Fig. 6E1-74--PAIR Pipe "A"

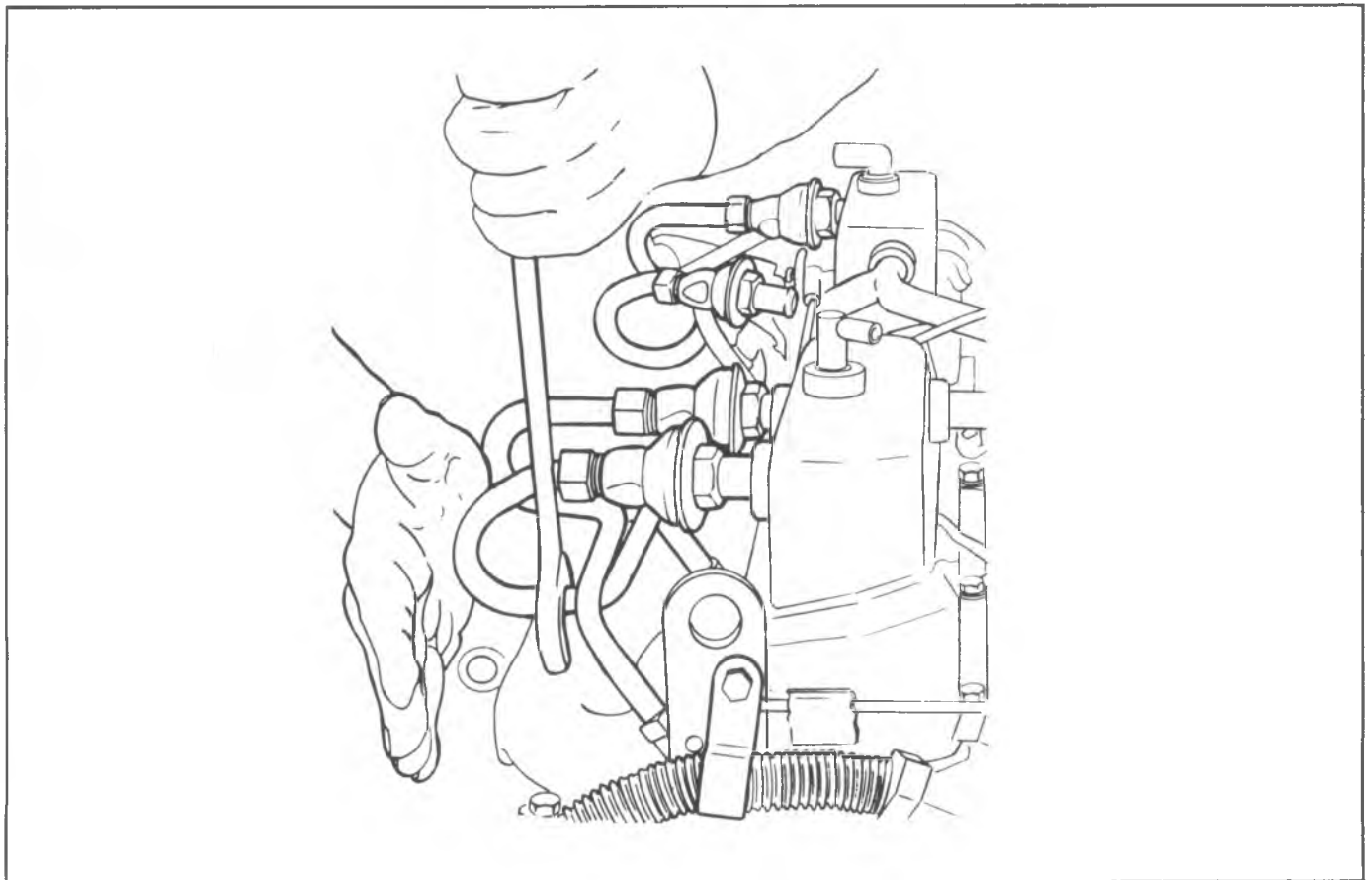

Fig. 6E1-75--PAIR Pipe "B"

## DECELERATION VALVE

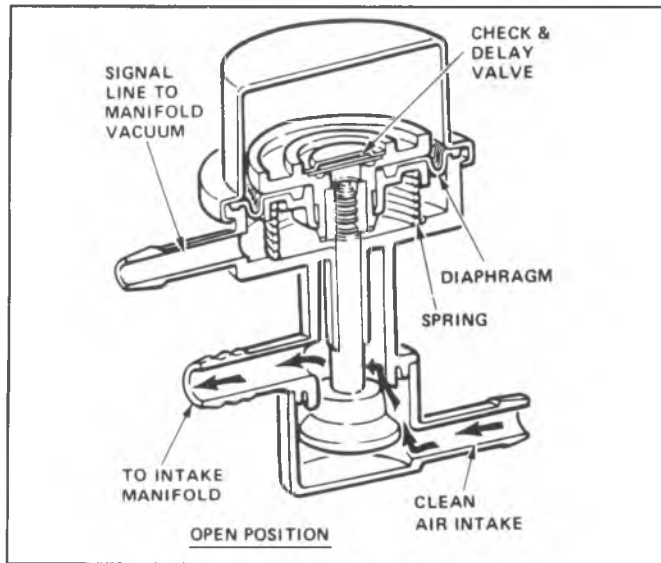

Fig. 6E1-76--Deceleration Valve-Cutaway

### GENERAL

A deceleration valve (Fig. 6E1-76) is used on all L6 and V8 (automatic transmission) engines to prevent backfiring in the exhaust system during deceleration. When deceleration causes a sudden vacuum increase in the vacuum signal line, the pressure differential on the diaphragm will overcome the closing force of the spring, opening the valve and bleeding air into the intake manifold.

Air trapped in the chamber above the vacuum diaphragm will bleed at a calibrated rate through the delay valve portion of the integral "Check and Delay Valve", reducing the vacuum acting on the diaphragm. When the vacuum load on the diaphragm and the spring load become equal, the valve assembly will close, shutting off the air flow into the intake manifold.

The check valve portion of the "Check and Delay

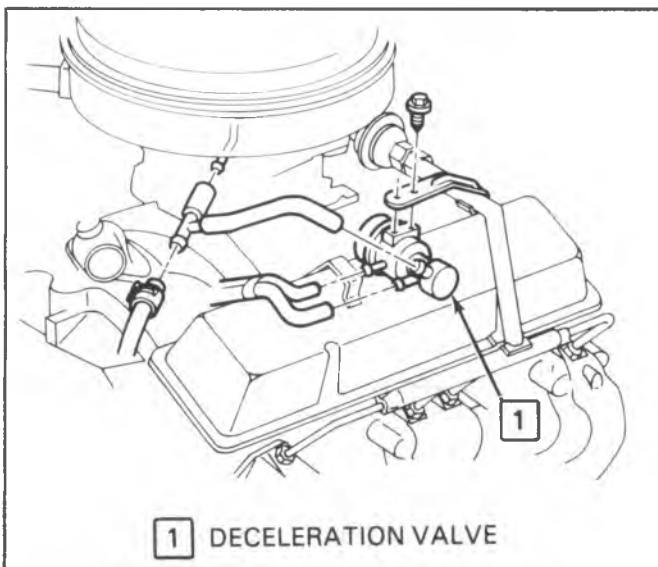

Fig. 6E1-78--Deceleration Valve-V8 G Series

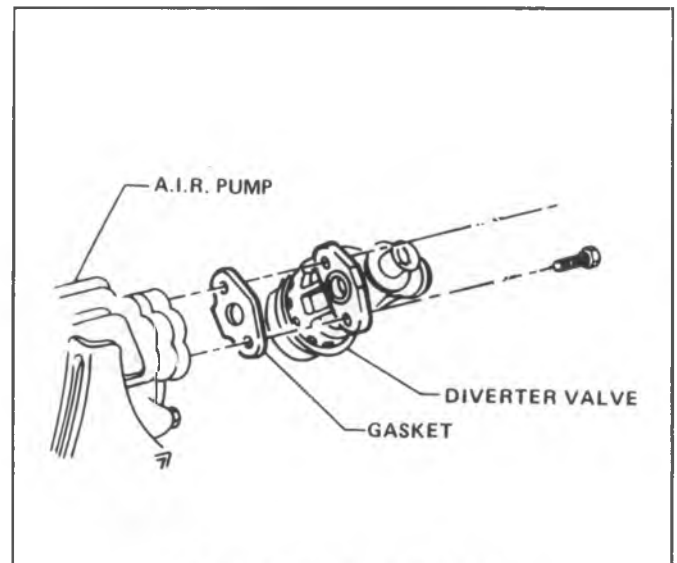

Fig. 6E1-77--Deceleration Valve-L6

Valve" provides quick balancing of chamber pressure when a sudden decrease in vacuum is caused by acceleration rather than deceleration.

### DIAGNOSIS

#### Functional Check

1. Remove air cleaner, plug air cleaner vacuum source and connect tachometer.
2. With the engine running at specified idle speed, remove the small deceleration valve signal hose from the manifold vacuum source.
3. Reconnect the signal hose and listen for air flow through the ventilation pipe and into the deceleration valve. There should also be a noticeable speed drop when the signal hose is reconnected.
4. If the air flow does not persist for at least one second or the engine speed does not drop noticeably, check the deceleration valve hoses for restrictions or leaks.
5. If no restrictions or leaks are found, replace the deceleration valve.
6. On manual transmission vehicles, if the deceleration valve functions normally, check the throttle SSC function (refer to carburetor on vehicle service.)

### ON-VEHICLE SERVICE

#### Replacement

1. Remove vacuum hoses from valve.
2. Remove two screws securing valve to engine bracket and remove valve.
3. Install valve and tighten screws to engine bracket.
4. Install vacuum hoses.

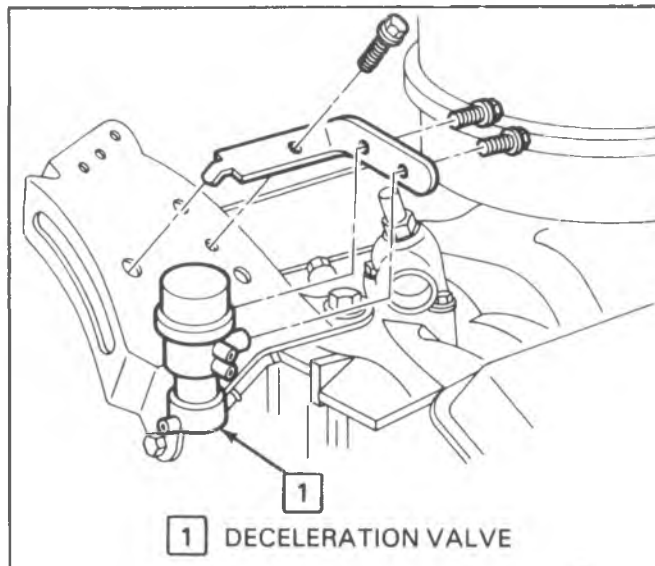

Fig. 6E1-79--Deceleration Valve-V8 CK Series

## EVAPORATIVE EMISSION CONTROL SYSTEM (EECS)

### GENERAL

All light duty emissions and some heavy duty emission vehicles are equipped with a system designed to prevent escape of fuel vapor to the atmosphere. Vapor generated by evaporation of fuel in the tank, previously exhausted to atmosphere, is transferred by an emission line to the engine compartment. During periods of operation, vapors are fed directly to the engine for consumption. During periods of inoperation, an activated charcoal canister located in the emission line stores any vapor generated for consumption during the next period of operation (Figs. 6E1-80 and 81).

The amount of vapor drawn into the engine at any time is too small to have any effect on fuel economy or engine operation.

With this closed system it is extremely important that only vapors be transferred to the engine. To avoid the possibility of liquid fuel being drawn into the system, these following features are included as part of the total system:

1. A fuel tank overfill protector is provided on all series to assure adequate room for expansion of liquid fuel volume with temperature changes.
2. A one point fuel tank venting system is provided on all series to assure that the tank will be vented under any conceivable vehicle attitude.
3. To protect the tank from mechanical damage in the event of excessive internal or external pressures resulting from the operation of this closed system, a pressure-vacuum relief valve, located in the gas cap, will control the tank internal pressure.

On 5.0L (LF3) and 5.7L (LS9) in California, the ECM controls the vacuum to the purge valve in the charcoal canister with a solenoid valve. When the system is in open loop, the solenoid valve is energized and blocks vacuum to the purge valve. When the system is in closed loop, above specified RPM, the solenoid valve is de-energized and vacuum can be applied to the purge valve. This releases the collected vapors into the intake manifold.

Refer to Figure 6E1-80 for solenoid valve location.

### DIAGNOSIS

#### Pressure Checking System

1. Stabilize vehicle by operating until warmed up.
2. Remove tank line at canister and observe for liquid in the line. Hook-up pressure device.
3. Apply 15" H<sub>2</sub>O pressure to the fuel vapor line.
  - a. Observe for excessive loss of pressure.
  - b. If negligible pressure loss occurs, observe for fuel vapor smell or fuel loss at points listed in Diagnostics under Possible Cause.
  - c. Remove fuel filler cap(s) and observe for pressure in tank(s).
4. Remove fuel cap (LH on dual tank units) and blow on vent line to check for obstructions. (Install LH cap on dual tank units and remove RH cap. Repeat above).

#### Checking Purge Valve

1. Remove purge valve control vacuum line. Check for vacuum signal with engine operating above idle (1500 RPM). If no vacuum signal, perform EGR System Function Check.
2. Apply an external vacuum source to the purge valve control diaphragm. A good valve will hold vacuum.
3. If the valve will not hold vacuum, replace canister.
4. If valve holds vacuum, remove purge line and check for vacuum. If no vacuum, check PCV hoses and system. Repair if or replace as necessary.

#### Checking Bowl Vent Valve

1. Remove the bowl vent vapor hoses from the carburetor.
2. Check the open condition of the valve by connecting to a manual vacuum pump. It should not be possible to obtain .5 inch Hg if the valve is open.

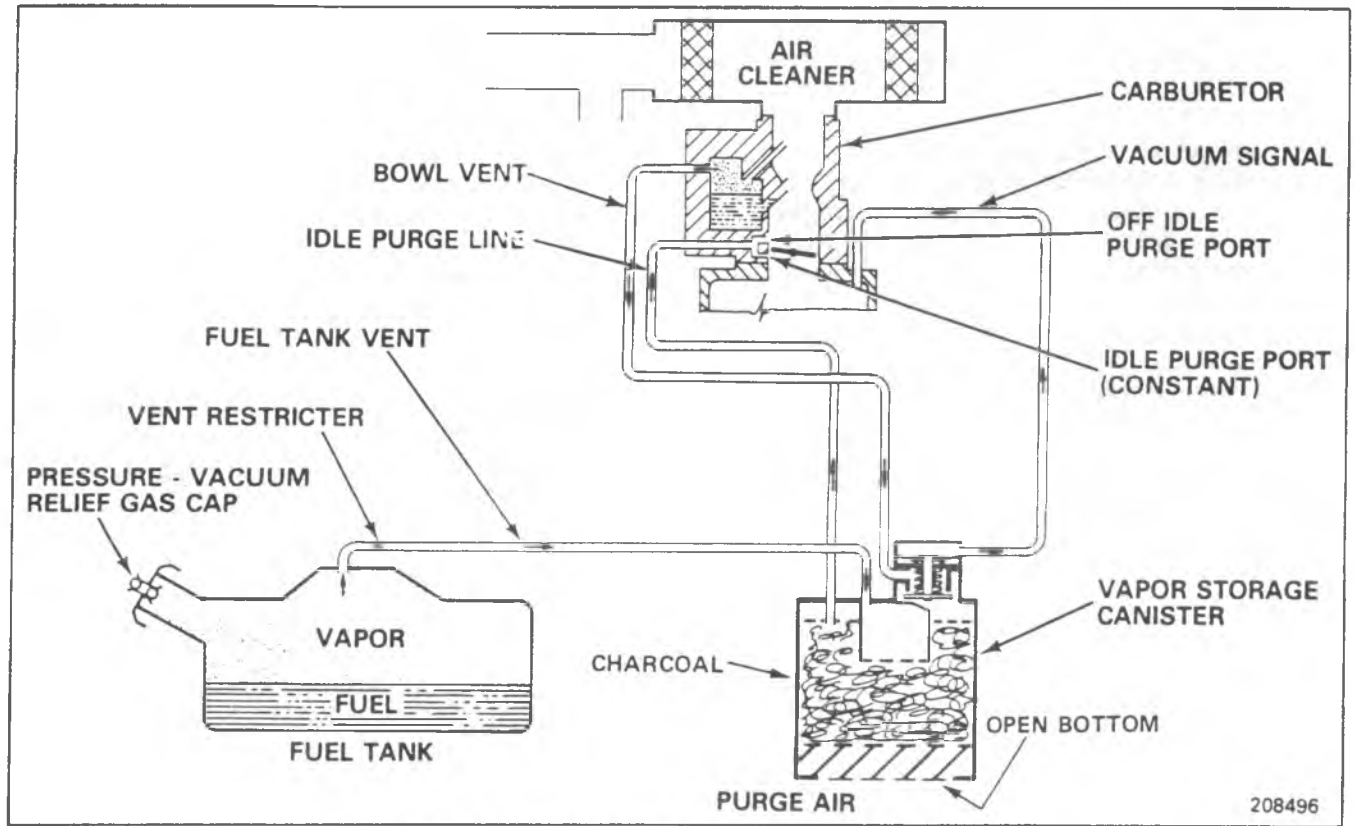

208496

Fig. 6E1-80--Evaporative Emission Control System-Open Canister

3. If a high resistance or plugged system is found, check for a plugged or restricted hose. Hose may be cleared with compressed air. If the hole is clear, remove the canister filler. If the restriction persists, replace the canister.
4. A simple check of the valve closed condition can be obtained with the same procedure as in Step 2, but with the engine operating at operating temperature. Manifold vacuum will be applied to the valve through the control line. The bowl vent line should exhibit a plugged condition.
5. If the valve is not closed, remove the control vacuum line and check for vacuum. If no vacuum is present, check hose for restriction or vacuum leak. Repair or replace as required. If vacuum is present, replace canister.

Refer to Figure 6E1-81 for diagnosis of the canister purge valve if controlled by a solenoid and the ECM.

### ON-VEHICLE SERVICE

Maintenance requirement is that the oiled fiberglass filter assembled in the bottom of the canister, be replaced at

intervals shown in Section 0B. Under extremely dusty conditions, more frequent attention may be required.

Check operation of bowl vent and purge valve.

### Canister Filter Replacement

1. Remove all hoses from top of canister. Remove canister following normal service procedures.
2. Remove filter element by squeezing it out from under lip surface at bottom of canister, and from under retainer bar, where used.
3. Squeeze new element under retainer bar, where used, and position it evenly around entire bottom of canister. Tuck edges under lip of canister.
4. Reinstall canister to original position on vehicle, following normal service procedures.
5. Reconnect hoses to top of canister according to the labeling on top of the canister.

1983 CCC  
CANISTER PURGE VALVE CHECK

Check purge hose condition and connections. Repair as necessary:

- Ignition "ON," engine stopped.
- Ground "test" terminal.
- Apply vacuum to carb. side of purge solenoid (at solenoid) with hand vacuum pump. Should be able to get 34 kPa (10" Hg.) on all but 3.8L Turbo V-6 in "G" Series. It has a built-in leak. Should be able to get 7 kPa (2" Hg.) at least momentarily.

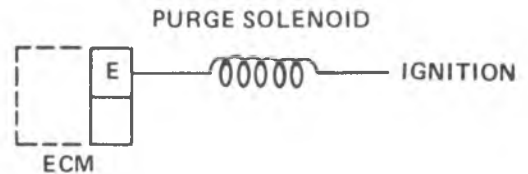
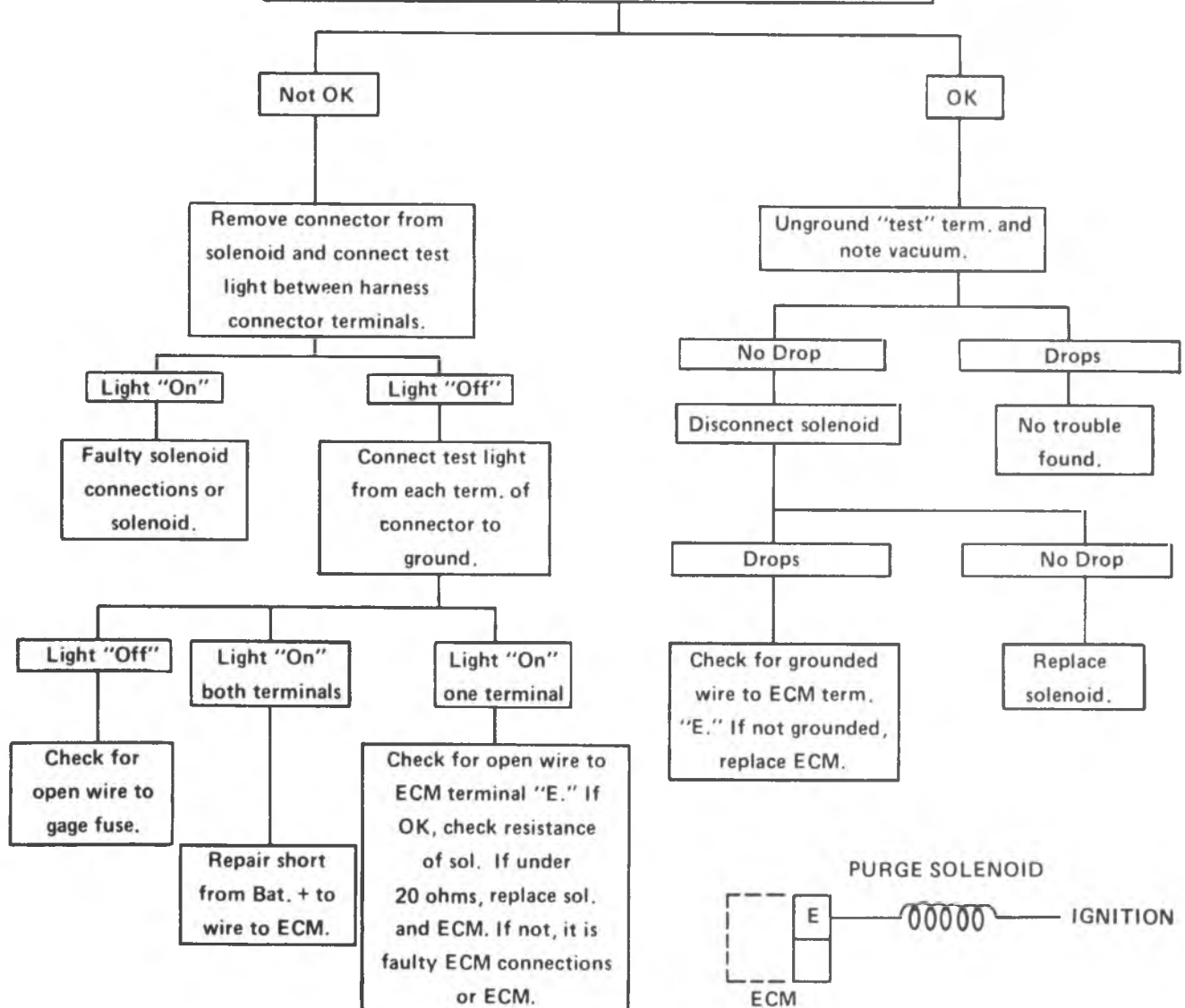

D2481Z  
10481Z

Fig. 6E1-81--Canister Purge Valve Check-V8 Only



## ELECTRONIC SPARK TIMING (EST)

### GENERAL

Electronic Spark Timing (EST) distributor contains no vacuum or centrifugal advance and uses a seven-terminal HEI module. A reference pulse, indicating both engine RPM and crankshaft position, is sent to the ECM. The ECM determines the proper spark advance for the engine operating conditions and sends an "EST" pulse to the distributor.

Under normal operating conditions, the ECM will control the spark advance. However, under certain operating conditions such as cranking or when setting base timing, the distributor can operate without ECM control. This condition is called "BYPASS" and is determined by the bypass lead from the ECM to the distributor. When the bypass lead is high (over 2 volts), the ECM will control the spark. Disconnecting the EST connector, or grounding the

by-pass lead causes the engine to operate in the bypass mode. There are trouble codes that will indicate a fault in EST circuit. Also Figures 6E1-82 and 6E1-83 provide additional diagnosis information. Refer to Section 6D for service procedures.

### Vacuum Sensor

The Vacuum sensor provides information (electrical signal) to the ECM to adjust air/fuel ratio and spark timing. There are trouble codes that will indicate a fault in the sensor circuit. Also refer to Figure 6E1-37 for information that checks the sensor circuit. Refer to Computer Command Control system for more information.

### Distributor Reference Pulses

Terminal "R" of the seven-terminal HEI module provides a reference pulse indicating engine RPM and crankshaft position to the ECM for EST use.

1983 CCC  
ENGINE CRANKS, BUT WILL NOT RUN  
(WITH INTEGRAL IGNITION COIL)

NOTE: Perform Diagnostic Circuit Check before using this procedure.  
If a tachometer is connected to the tachometer terminal, disconnect it before proceeding with the test.  
Intermittent no start may be caused by wrong pick-up or ignition coil.

1. Check spark at plug with ST-125 while cranking (if no spark on one wire, check a second wire). \*

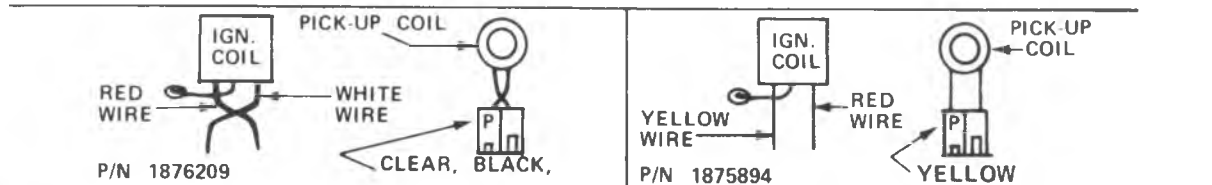
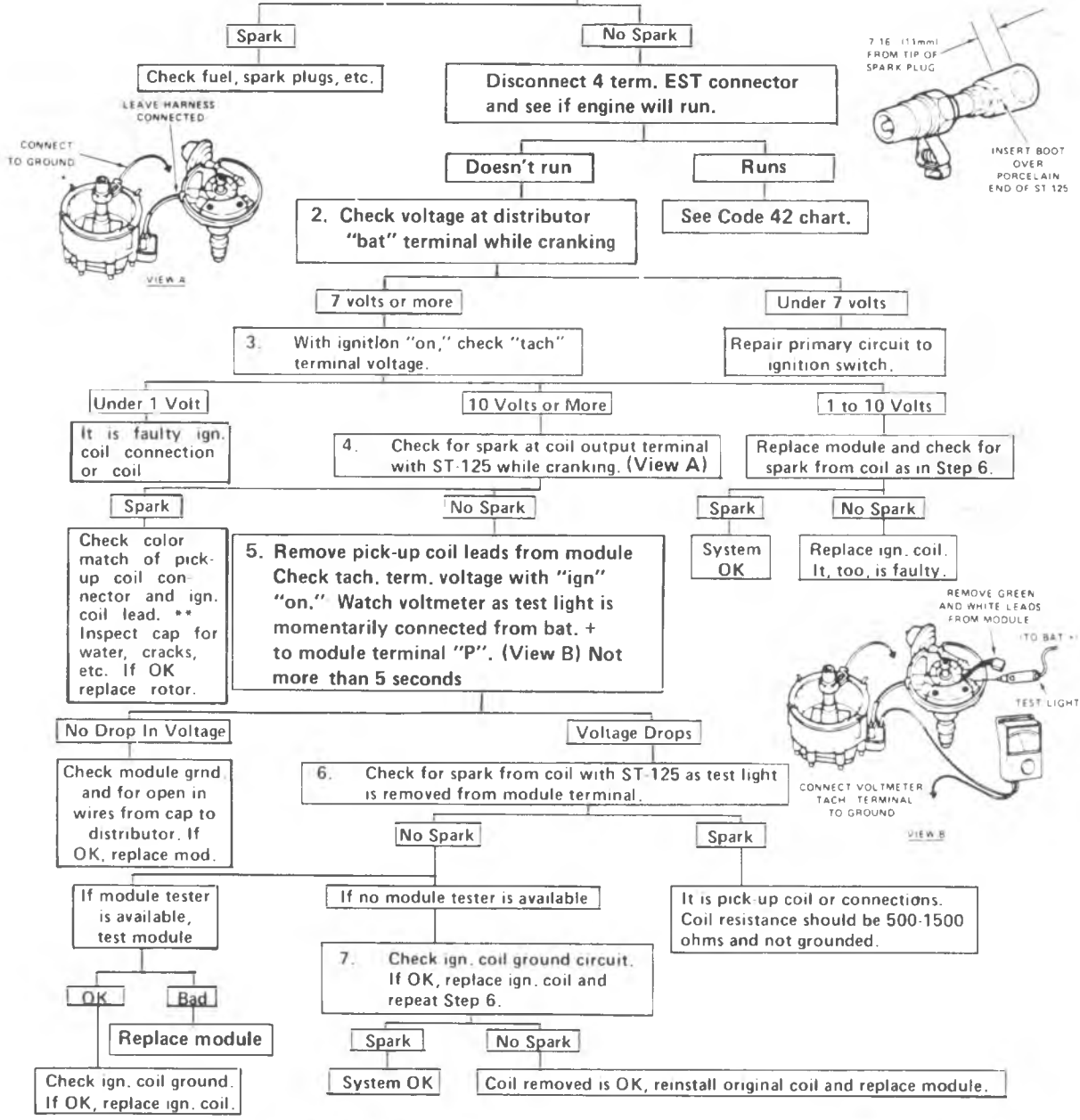

\* A few sparks and then nothing, is considered no spark.

Fig. 6E1-82-Engine Cranks, But Will Not Run (Integral Coil)

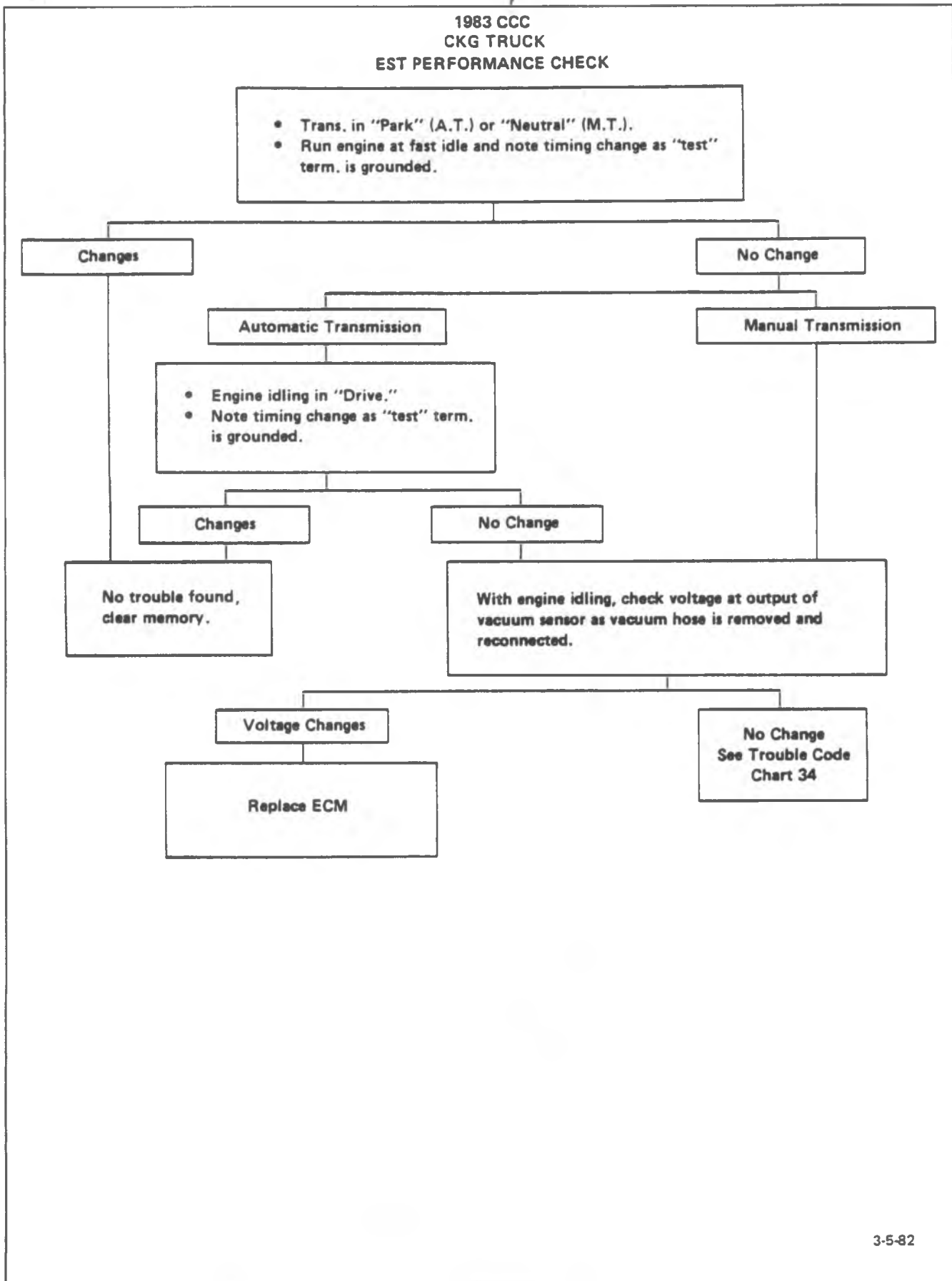

Fig. 6E1-83 EST CHECK

## TRANSMISSION CONVERTER CLUTCH (TCC)

### GENERAL

The ECM controls an electrical solenoid mounted in the automatic transmission. When the vehicle reaches a specific speed, the ECM energizes the solenoid and allows the torque converter to mechanically couple the engine to the transmission. When operating conditions indicate the transmission should operate as a normal fluid-coupled transmission (deceleration, passing, etc.), the solenoid is de-energized. The transmission also returns to normal (fluid-coupled) automatic operation when the brake pedal is depressed. Refer to Section 7A for service procedures.

### Stop Light Switch

The stoplight switch, located above the brake pedal, de-energizes the TCC when the brake pedal is depressed. Refer to Section 8 for service procedures.

### DIAGNOSIS

Refer to Figure 6E1-84 for electrical diagnosis of the transmission converter clutch.

### ON-VEHICLE SERVICE

#### TCC Solenoid

This solenoid, controlled by the ECM, operates the torque converter clutch. It is an internal transmission component. Service procedures for this solenoid will be found in the transmission section.

CKG TRUCK  
TRANSMISSION CONVERTER CLUTCH (TCC)  
ELECTRICAL DIAGNOSIS

Mechanical checks, such as linkage, oil level, etc., should be performed prior to using this chart.

- Connect test light from T.C.C. test point in Term. "F" in ALCL connector to ground.
- Four wheel drive vehicle should be in Two-wheel drive.
- With drive wheels off floor, trans. in gear, increase speed to 25 MPH and note light.

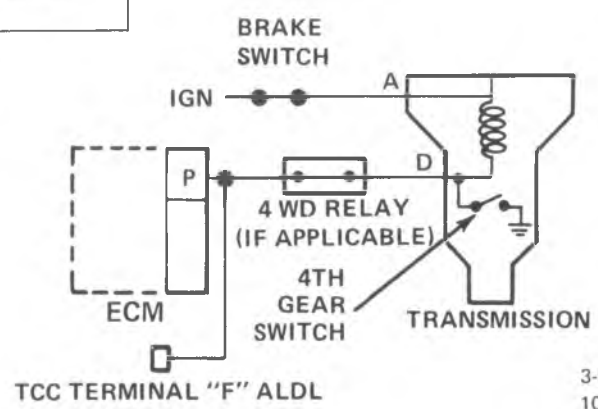
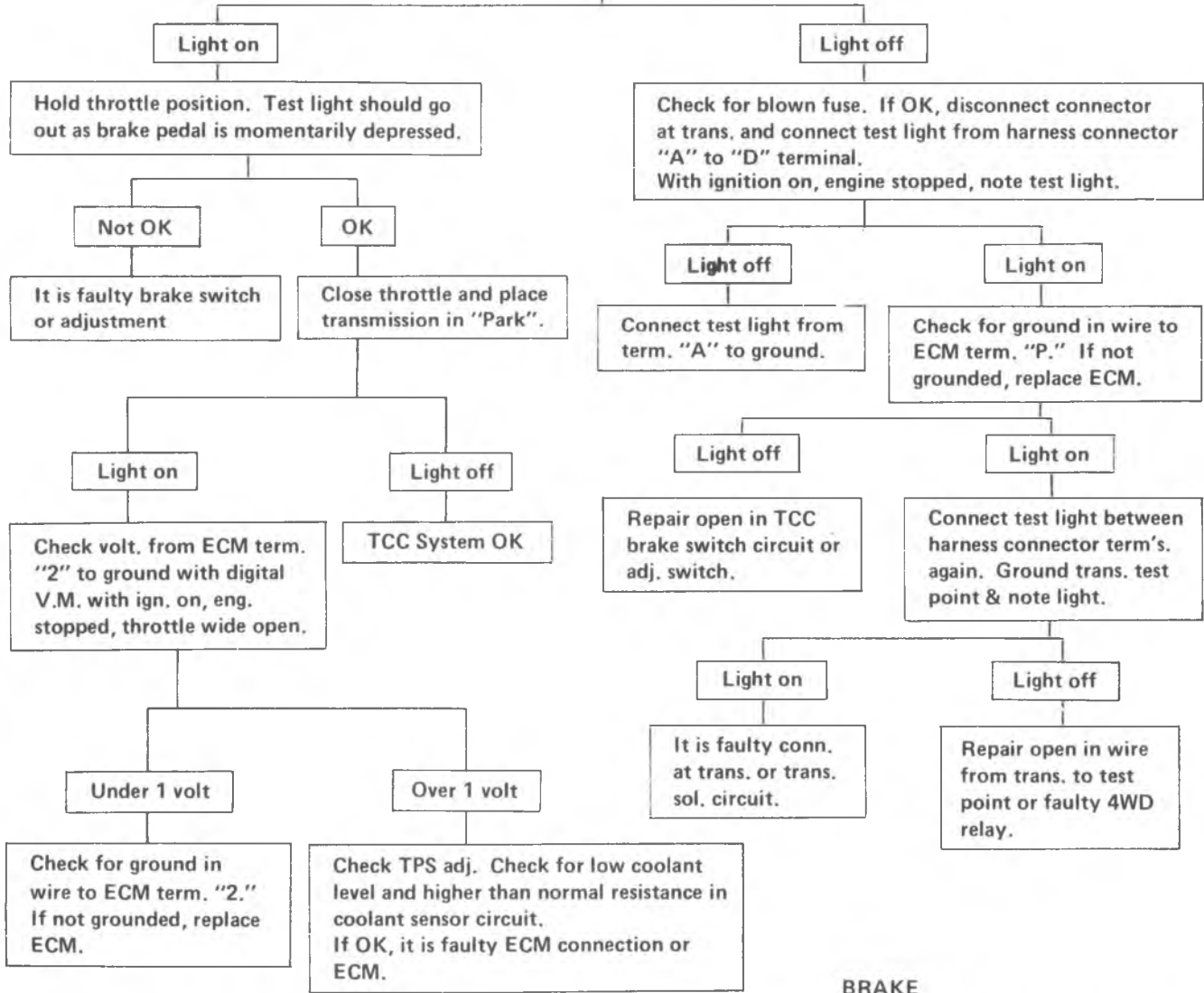

3-5-82  
104985

Fig. 6E1-84--Transmission Converter Clutch Electrical Diagnosis

## THROTTLE RETURN CONTROL (TRC) SYSTEM

### GENERAL

The TRC system (Figs. 6E1-85, 6E1-86 and 6E1-87), used on heavy duty emission vehicles, consists of three major components:

1. Throtte Lever Actuator - Mounted as part of the carburetor assembly, this device opens the primary throttle blades a preset amount in excess of curb idle when engine vacuum is applied to it. This actuating vacuum is controlled by a separate solenoid control valve.
2. Solenoid Vacuum Control Valve - Mounted separately from the carburetor, this off-on valve is held open above a preset nominal engine speed by a signal from an electronic speed sensor. The valve when open allows a vacuum signal to be applied to the throttle lever actuator as long as the present engine speed is exceeded.
3. Electronic Speed Sensor - Mounted separately from the solenoid vacuum control valve, this switching device monitors engine speed at the distributor and supplies a continuous electrical signal to the solenoid vacuum control valve as long as the preset engine speed is exceeded.

### CHECK AND ADJUSTMENT

Check hoses for cracking, abrasion, or deterioration and replace as necessary. Check for shorted or broken wires and ensure that electrical connectors are fully engaged at the distributor, speed switch and vacuum solenoid. Check system function for proper operation and adjust as necessary.

1. Connect precision tachometer (capable of resolving 10 RPM) to the distributor "TACH" terminal.
2. Start engine and advance throttle to indicated 1890 RPM. Throttle lever actuator should be extended at this speed.
3. Reduce throttle opening to indicated 1700 RPM. Throttle lever actuator should be retracted at this speed.
4. If the throttle lever actuator operates outside of the 1700 to 1890 RPM limits, the speed switch is out of calibration and should be replaced.
5. If the actuator does not operate at any speed, proceed with the following steps.
  - a. With a voltmeter, check for voltage at the vacuum solenoid and speed switch. This is accomplished by connecting the negative probe of the voltmeter to the engine "ground" and inserting the positive probe in the connector cavity of the voltage source wire. A voltage of 12-14 volts should be measured at this terminal on both the solenoid and speed switch. When making this measurement, it is not necessary to unplug the connector from its component. The voltmeter probe can be inserted in the connector body on the wire side of the connector to contact the metal terminal.

- b. If voltage is present at once device and not the other, repair the engine wiring harness as required.
  - c. If voltage is not present at either device, check the engine harness connections at the distributor and/or bulkhead connector. Repair as required.
  - d. If the proper voltage exists at each device, to check for proper solenoid valve operation "ground" the solenoid-to-switch connecting wire terminal at the solenoid connector using a jumper wire. The throttle lever actuator should extend (engine running).
  - e. If it does not extend, remove the hose from the solenoid side port that connects to the actuator hose. Visually check the orifice in this port for plugging. Clear the orifice as required. If not plugged, replace the solenoid.
  - f. If the actuator extends in Step D, ground the solenoid-to-switch wire terminal at the speed switch. If it does not extend, repair the wire connecting the speed switch and solenoid. If it does extend, check the speed switch ground wire for "ground" - it should read 0 volts when checked with a voltmeter with the engine running; check the speed switch-to-distributor wire for proper connection. With both the ground and distributor wires properly connected and if the actuator does not extend when operating above 1890 RPM, replace the speed switch.
6. If the actuator remains extended at all speeds, proceed as with the following steps.
    - a. Remove connector from vacuum solenoid.
    - b. If actuator remains extended, check the orifice in the solenoid side port for plugging. If plugged, clear and reconnect system and recheck. If the actuator again remains extended, remove the solenoid connector. If the actuator does not retract, replace the vacuum solenoid.
    - c. If the actuator retracts with the solenoid connector off, reconnect and then remove the speed switch connector. If the actuator retracts, replace the speed switch. If the actuator does not retract, the solenoid-to-switch wire is shorted to ground in the wiring harness. Repair as required.

### Throttle Lever Actuator - Checking Procedure

1. Disconnect valve to actuator hose at valve and connect to an external vacuum source equipped with a vacuum gage.
2. Apply 20 in. HG vacuum to the actuator and seal off the vacuum source. If the vacuum gage reading drops, then the actuator is leaking and must be replaced.
3. To check the actuator for proper operation:
  - a. Check the throttle lever, shaft, and linkage to be sure that they operate freely without binding or sticking.
  - b. Start engine and run until warmed up and idle is stable. Note idle rpm.
  - c. Apply 20 in HG vacuum to the actuator. Manually open the throttle slightly and allow to close against the extended actuator plunger. Note the engine rpm.
  - d. Release and reapply 20 in HG vacuum to the

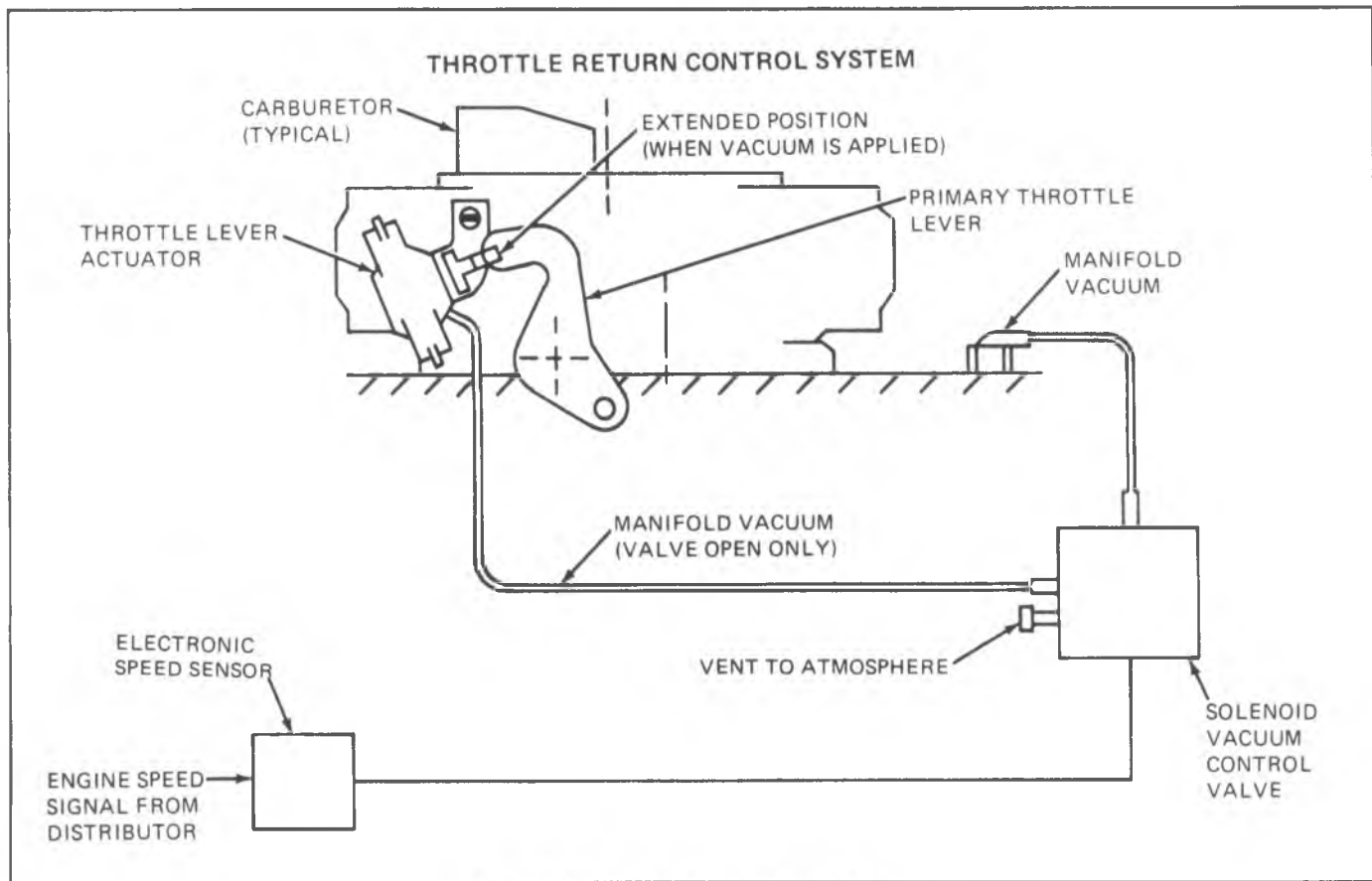

Fig. 6E1-85--Throttle Return Control System

actuator and note the rpm to which the engine speed increases (do not assist the actuator).

- e. If the rpm obtained in Step D is not within 150 rpm of that obtained in Step C, then the actuator plunger may be binding due to dirt, corrosion, varnish, etc., or the actuator diaphragm may be too weak. If binding is not indicated or cannot be corrected, then the actuator must be replaced.
- f. Release the vacuum from the actuator and the engine speed should return to within 50 rpm of the

idle speed noted in Step 2. If it does not, the plunger may be binding due to dirt, corrosion, varnish, etc. If the problem cannot be corrected, the actuator must be replaced.

- g. If the engine rpm noted in Step 3 is not within the specified TRC speed range, the TRC actuator must be adjusted. See Throttle Lever Actuator Adjusting Procedure in Section 6C.

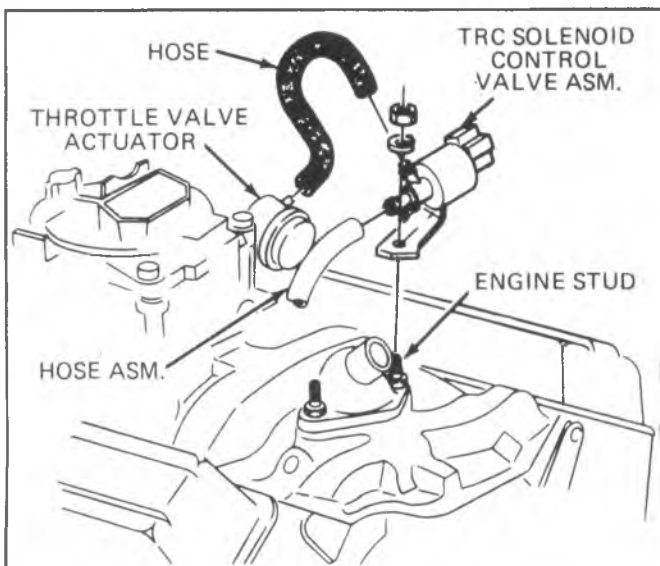

Fig. 6E1-86--TRC System-V8

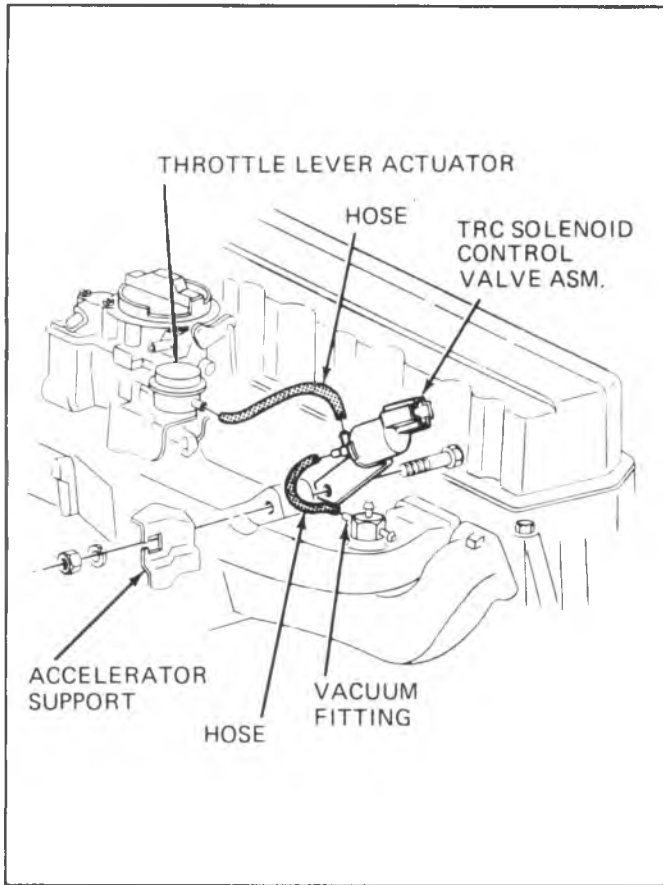
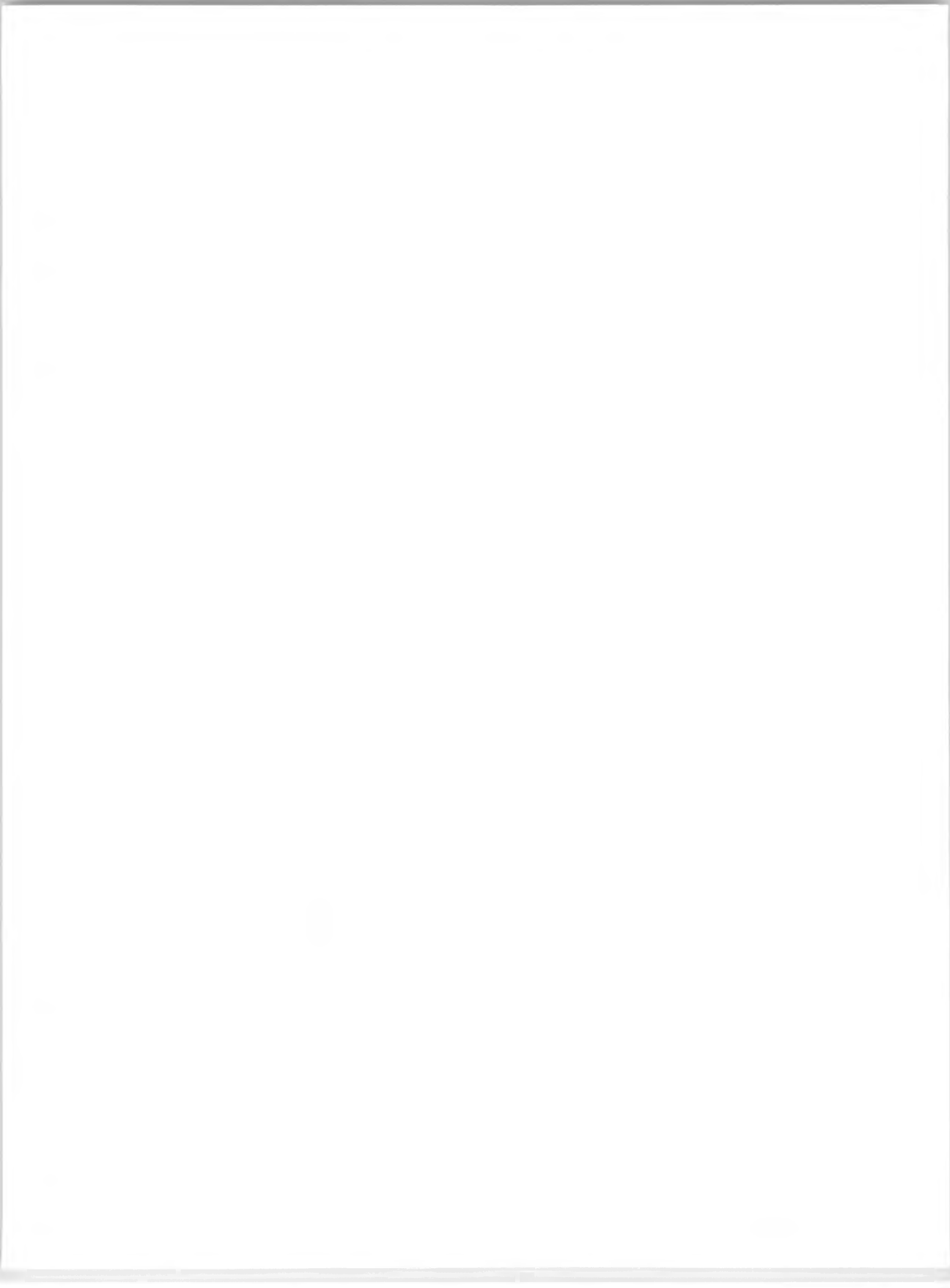

Fig. 6E1-87--TRC System-L6





## SECTION 6E3

# DIESEL EMISSIONS 6.2L

ALL NEW GENERAL MOTORS VEHICLES ARE CERTIFIED BY THE UNITED STATES ENVIRONMENTAL PROTECTION AGENCY AS CONFORMING TO THE REQUIREMENTS OF THE REGULATIONS FOR THE CONTROL OF AIR POLLUTION FROM NEW MOTOR VEHICLES. THIS CERTIFICATION IS CONTINGENT ON CERTAIN ADJUSTMENTS BEING SET TO FACTORY STANDARDS. IN MOST CASES, THESE ADJUSTMENT POINTS EITHER HAVE BEEN PERMANENTLY SEALED AND/OR MADE INACCESSIBLE TO PREVENT INDISCRIMINATE OR ROUTINE ADJUSTMENT IN THE FIELD, FOR THIS REASON, THE FACTORY PROCEDURE FOR TEMPORARILY REMOVING PLUGS, CAPS, ETC., FOR THE PURPOSES OF SERVICING THE PRODUCT MUST BE STRICTLY FOLLOWED AND, WHENEVER PRACTICABLE, RETURNED TO THE ORIGINAL INTENT OF THE DESIGN.

### CONTENTS

|                                       |       |                                     |       |
|---------------------------------------|-------|-------------------------------------|-------|
| Emission System.....                  | 6E3-1 | Vacuum Regulator Valve.....         | 6E3-4 |
| Exhaust Pressure Regulator (EPR)..... | 6E3-2 | Crankcase Depression Regulator..... | 6E3-5 |
| Exhaust Gas Recirculation.....        | 6E3-2 | Vacuum Pump.....                    | 6E2-5 |
| EGR Diagnosis.....                    | 6E3-2 | Wiring Diagrams.....                | 6E3-6 |
| Throttle Position Switch.....         | 6E3-4 | Component Locations.....            | 6E3-8 |

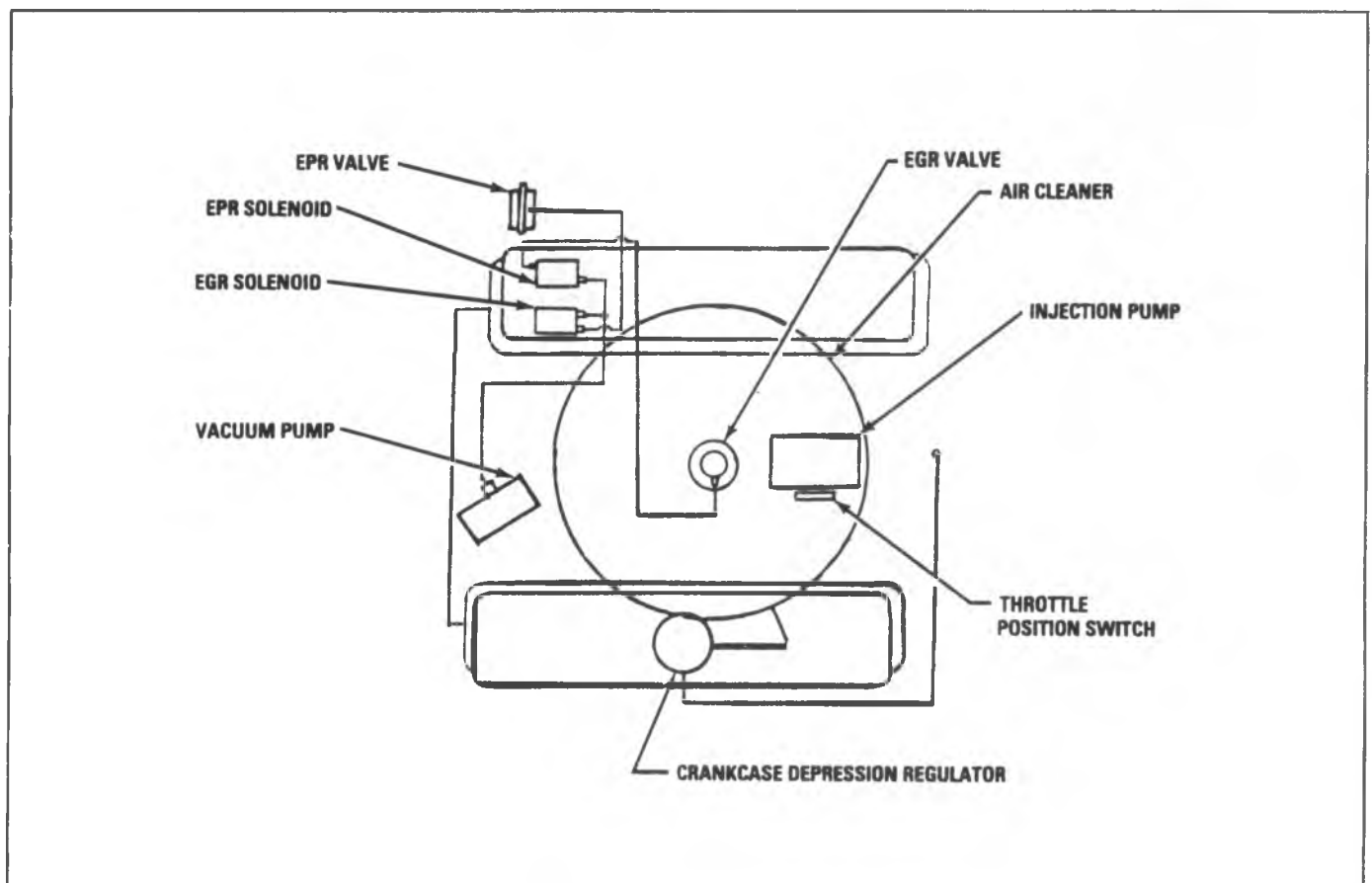

Fig. 6E3-1--Emission Systems

### EMISSION SYSTEMS

1. Exhaust Pressure Regulator
2. Exhaust Gas Recirculation
3. Throttle Position Switch is used in conjunction with the EPR/EGR solenoids to activate them.

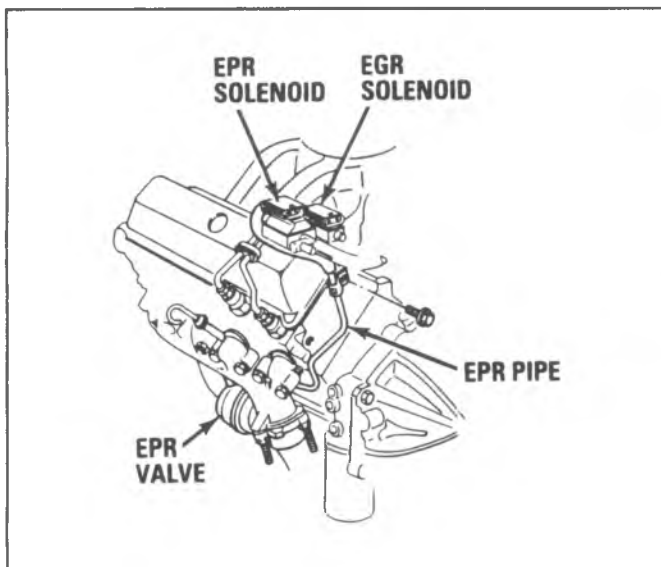

Fig. 6E3-2--EPR Valve

4. Crankcase Depression Regulator

5. Vacuum Pump

The EPR valve function is to increase exhaust back-pressure during idle in order to increase EGR flow to reduce NO<sub>x</sub> emissions. It is only used on the LH6 Lt. duty engine equipped with EGR. The EPR valve is normally open. See Fig. 6E3-2.

EGR is designed to control (Oxides of Nitrogen) NO<sub>x</sub>. This is done by blending the fuel-air with exhaust gases to reduce the peak temperatures and therefore reduce NO<sub>x</sub>. The NO<sub>x</sub> oxygen content of this exhaust gas is quite low. This spent gas is run through an EGR valve to the manifold, and then is part of the air intake. This is introduced into the combustion chamber. It takes up some of the volume of the incoming charge of air. When ignition takes place, the spent exhaust gases cannot partake in the combustion process, since they have already been used previously, so they add nothing. As the flame travels in the cylinder, the temperature increases quite rapidly. The temperature rise cause the gases to expand. The temperature in the chamber is much higher than the exhaust gases. The spent gases now take part in the process. They cannot add to the process because of lack of O<sub>2</sub>. So the spent or inert gas acts as a sponge and pulls heat into itself causing it to expand. As it does, it absorbs heat of combustion and drops the temperature approximately 500°F. Carbon monoxide is not a significant emission factor with diesels. Hydrocarbon are controlled by the injector nozzles, pump timing and combustion chamber design.

#### VACUUM SWITCHED EPR (FIG. 6E3-2)

The EPR solenoid is normally closed. When energized by (B+) from the TPS, it is open allowing vacuum to the EPR, closing it. This occurs at idle. As the throttle is opened, at a calibrated throttle angle the TPS de-energizes the EPR solenoid, cutting off vacuum to the EPR valve and opening it.

#### VACUUM SWITCHED EGR (FIG. 6E3-3)

With vacuum switched EGR, either full flow or no flow of exhaust gas is admitted to the intake manifold. At closed throttle, the EGR is opened. The EGR valve remains fully

open to a calibrated throttle position is sensed by a throttle position switch (TPS) mounted on the throttle shaft on the injection pump.

With TPS, as the throttle is opened, the switch closes at the calibration point. It energizes a solenoid which is normally open. This cuts off the vacuum signal to the EGR valve, allowing the valve to close.

EGR is not used on the LL4 heavy duty version in the 20,2500 and 30 and 3500 series trucks.

#### Fig 6E3-3 Shows EGR Flow

The throttle position switch just has 2 contact inside it: One to send (B+) at idle on a blue wire to the EPR solenoid which is N.C. and this opens the solenoid valve and closes the EPR valve. The other contact will send (B+) on a yellow wire to the EGR solenoid, at a specified throttle angle. The EGR solenoid is N.O. This current closes the EGR solenoid, closing the EGR valve. There is a delay on some switches in the time when the EPR opens and the EGR closes. There are three different cams used to change EPR/EGR switch points:

- Blue Cam 0°Difference
- Black Cam 5°Difference
- Red Cam 10°Difference

Fig. 6E3-4 summarizes the EGR/EPR valve and solenoid operations. Heavy black exhaust smoke upon acceleration generally indicates a malfunction in the EGR system.

#### EGR/EPR PROBLEM DIAGNOSIS

1. Start engine and operate to open thermostat temperature.
2. Remove air cleaner cover to observe operation of EGR valve (View A).
3. With engine at idle the EGR valve should be open. (Observe valve head in up position and noticeable exhaust noise intake.) If not, check and correct any electrical and hose connection which may be loose and/or disconnected.
4. Remove vacuum hose from EGR valve. The valve head should drop with a noticeable reduction in noise. Reconnect hose.
5. At idle the hose to the EGR valve should have approximately 20 inches of vacuum. If vacuum is not present, check output of the vacuum pump at the pump. The pump should produce a minimum of 20 inches of vacuum.
6. If vacuum is present at the EGR valve but the valve does not open and close as the hose is put on and taken off, the EGR valve is stuck and should be checked and replaced if necessary.
7. Manually operate the throttle lever at the injection pump through approximately 15° to 20° of travel. The EGR valve should close when the TPS reaches the calibrated point.
8. Check the pink wire to the TPS for 12 volts (key on). If 12 volts is not present, check for any loose connections, open wire, and a blown 20 amp gage fuse (View D).
9. Correct any lose wire connections and change fuse. With key on, the blue wire from the TPS switch should also have 12 volts. This blue wire feeds the EPR solenoid. At idle if the pink wire has 12 volts but

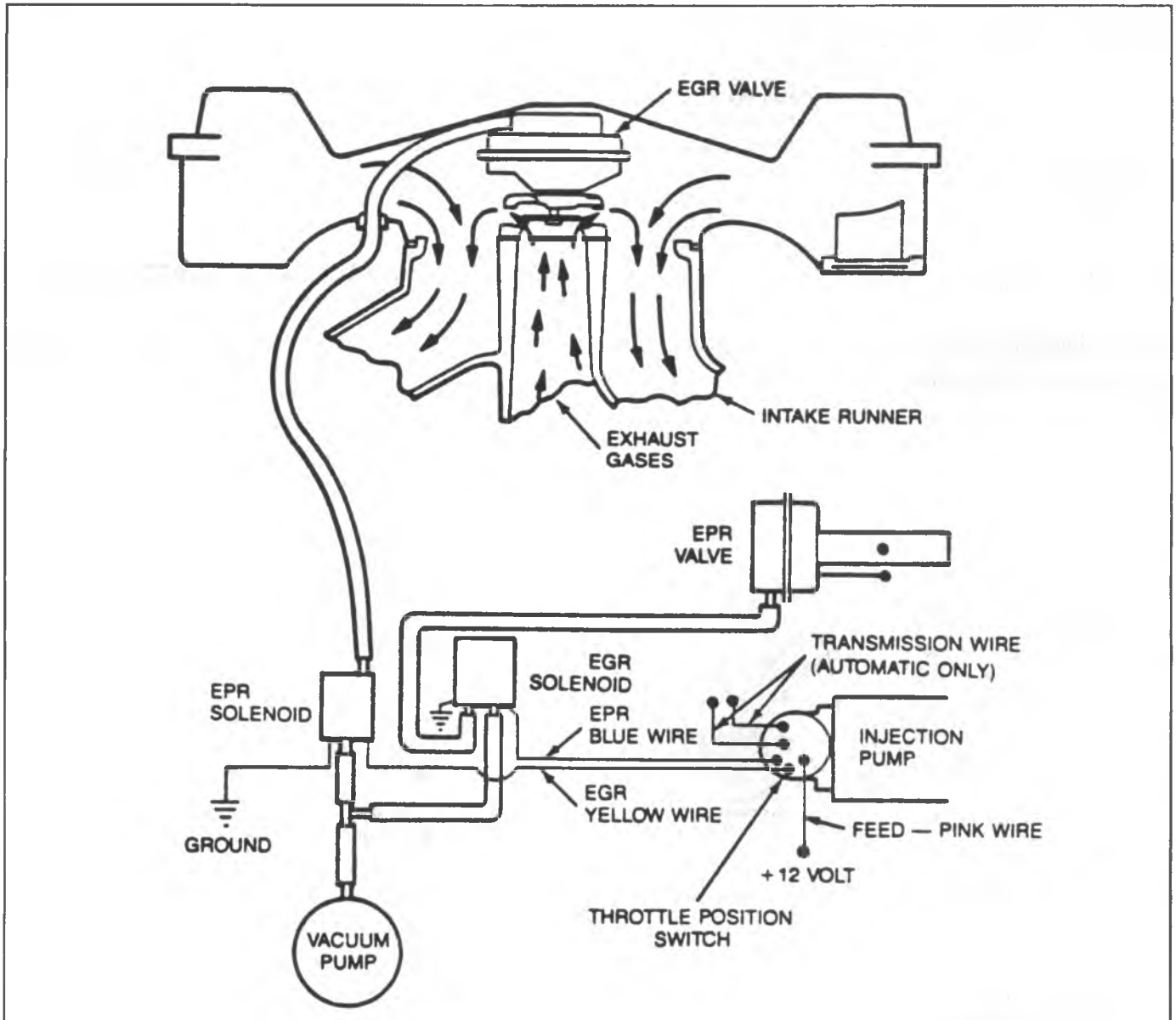

Fig. 6E3-3--EGR System

the blue one does not, the TPS is inoperative and should be changed

10. With engine off, but key on, operate the throttle through 20° travel. At approximately 15°, the TPS will cut out the 12 volts to the blue wire (EPR). At

approximately 20°, the TPS will cut in 12 volts to the yellow wire (EGR). If not, the TPS is inoperative.

11. Check to see that the electrical connections are made at the EGR-EPR solenoid assembly and that the hoses are routed correctly and connected to the solenoids.
12. If vacuum is present at the solenoid assembly and the solenoids are receiving an electrical signal as previously mentioned and operation of the TPS through the calibrated points does not operate the EGR and/or EPR valves, the solenoid assembly is inoperative and should be replaced.

| ENGINE SPEED         | EGR VALVE | EGR SOL.                        | EPR VALVE | EPR SOL.                           |
|----------------------|-----------|---------------------------------|-----------|------------------------------------|
| Idle to 15° Throttle | Open      | Not Energized (Vacuum to Valve) | Closed    | Energized (Vacuum to Valve)        |
| 15° to 20° Throttle  | Open      | Not Energized (Vacuum to Valve) | Open      | Not Energized (No Vacuum to Valve) |
| 20° to Full Throttle | Closed    | Energized (No Vacuum to Valve)  | Open      | Not Energized (No Vacuum to Valve) |

Fig. 6E3-4--EGR Summary

There is a third switch incorporated in the throttle position switch used with the Lt. duty automatic transmission, MD8 the 700-R4. This switch disengages the converter at a throttle angle of less than 8 degrees.

See Fig. 6E2-10 wiring schematic. This switch controls (B+) coming from the brake switch to the TCC solenoid. It prevents converter clutch operation below 16 degrees of throttle opening.

On a 4-wheel drive (Fig. 6E3-11) Diesel Truck, there is a N.C. relay in the parallel path of current to the T.C.C. solenoid, at pin B of the connector at the transmission. It is energized by grounding at pin 4 of the relay.

Pin 4 is grounded through the 4 wheel drive indicator switch in the transfer case. It is grounded in either 4 high or 4 low. When the relay is grounded, the N.C. relay is switched to open interrupting the B+ path to pin B of the transmission connector. The only way to have converter clutch operation in 4 wheel drive is, to close the 4th gear switch in the transmission allowing B+ from the other parallel path at pin A to pass through the now closed contacts of the 4th gear switch to the T.C.C. solenoid.

### DIESEL ENGINE THROTTLE POSITION SWITCH SETTING PROCEDURE (FIG. 6E3-7)

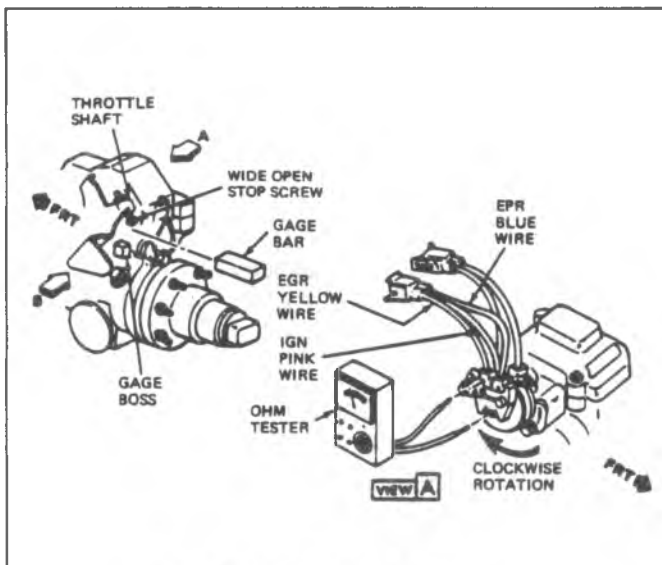

Fig. 6E3-5--LH6 TPS Adjustment

1. Loosen assembly throttle position switch to fuel injection pump with throttle lever in closed position.
2. Attach a continuity meter across the IGN (pink) and EGR (yellow) terminals or wires.
3. Insert the proper "switch-on" gage block between the gage boss on the injection pump and the wide open stop screw on the throttle shaft. (Gage block listed on emission label).
4. Rotate and hold the throttle lever against the gage block.
5. Rotate the throttle switch clockwise (facing throttle switch) until continuity pivot occurs (low meter reading) across the IGN and EGR terminals or wires. Hold switch body at this position and tighten mounting screws to specified torque.
6. Release throttle lever and allow it to return to idle position. Remove the "switch-on" gage bar and insert the "switch-off" gage bar. Rotate throttle lever against "switch-off" gage bar. There should be no continuity (meter reads resistance infinity) across the IGN and EGR terminals or wires. If not continuity exists, switch

is set properly. However, if there is continuity, then the switch must be reset by returning to Step 1 and repeating the entire procedure.

### LL4 (M40) VACUUM REGULATOR VALVE

On the heavy duty applications over 8500 lbs. GVWR. A VRV valve similar to those used on the 5.7L will be used to supply an engine load vacuum signal to the modulator on the M40 hydramatic 400 transmission. See Fig. 6E3-6.

### TRANSMISSION VACUUM REGULATOR VALVE ADJUSTMENT (LL4)

1. Attach the vacuum regulator valve snugly, but loosely to the fuel injection pump. The switch body must be free to rotate on the pump.
  2. Attach vacuum source of  $67 \pm 5$  kpa (20" Hg.) to inboard vacuum nipple. Attach vacuum gage to outboard vacuum nipple.
  3. Insert vacuum regulator valve gage bar between the gage boss on the injection pump and the wide open stop screw on the throttle lever. (Switch on position).
  4. Rotate and hold the throttle shaft against the gage bar.
  5. Slowly rotate the vacuum regulator valve body clockwise (facing valve) until vacuum gage reads  $39 \pm 2$  kpa (11.5" Hg.). Hold valve body at this position and tighten mounting screws.
- NOTICE:** Valve must be set while rotating valve body in clockwise direction only.
6. Check by releasing the throttle shaft allowing it to return to the idle stop position. Then rotate throttle shaft back against the gage bar to determine if vacuum gage reads within  $39 \pm 2$  kpa (11.5" Hg.). If vacuum is outside limits, reset valve.

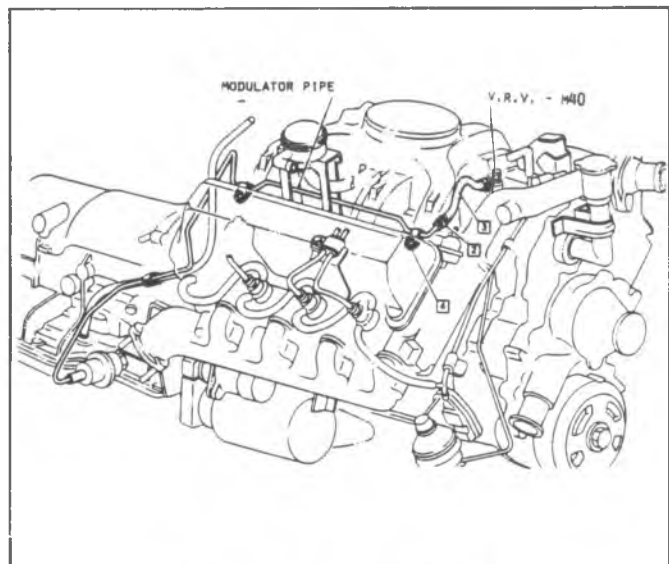

Fig. 6E3-6--VRV LL4 Heavy Duty

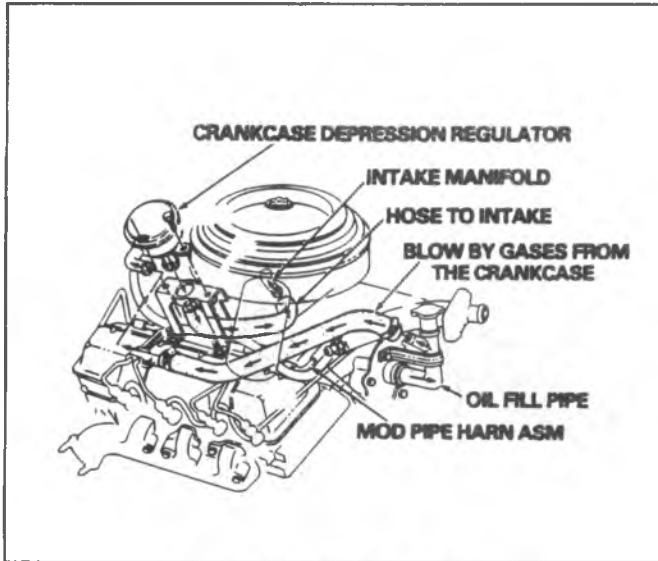

Fig. 6E3-7--Typical CDR Valve

**CRANKCASE DEPRESSION REGULATOR (FIG. 6E3-7)**

This valve is designed to limit vacuum to a maximum of 3-4 inches of H<sub>2</sub>O in the crankcase as the gases (blowby) are drawn from the oil fill pipe through the CDR valve and into the intake manifold.

The intake manifold vacuum acts against a spring loaded diaphragm to control the flow of crankcase gases. Higher intake vacuum levels pull the diaphragm closer to the top of the outlet tube. This reduces the amount of gases being drawn from the crankcase and decreases the vacuum level in the crankcase. As the intake vacuum decreases, the spring pushes the diaphragm away from the top of the outlet tube allowing more gases to flow to the intake manifold. See Fig. 6E3-8 for CDR schematic. The CDR valve regulates the crankcase to a nominal of 4 inches of depression (water).

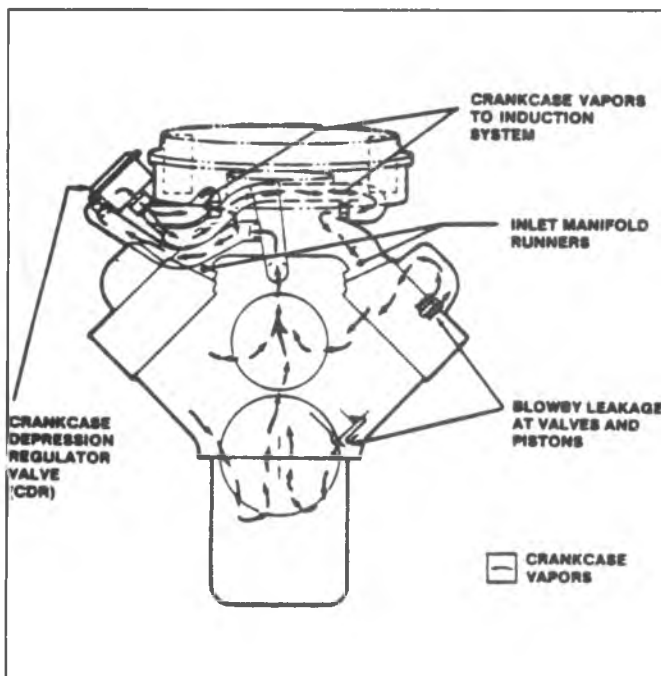

Fig. 6E3-8--CDR Schematic

**VACUUM PUMP (FIG. 6E3-9)**

Since the air crossover and intake manifold are unrestricted, no vacuum source is available as found in gasoline engines. To provide vacuum, a vacuum pump (Fig. 6E3-9) is mounted in the location occupied by the distributor in the gasoline engine. This vacuum pump supplies the air conditioning servos, cruise control servo, and transmission vacuum modulator where required.

It is a diaphragm pump which needs no periodic maintenance. It is driven by a cam inside the drive assembly to which it mounts. The pump's diaphragm moves back and forth causing air to flow into the inlet tube, through the pump, and exhaust out the rear port.

The drive housing assembly has a drive gear on the lower end which meshes with the cam shaft gear in the engine. This drive gear causes the cam in the drive housing to rotate. The drive gear also powers the engine oil lubricating pump.

**NOTICE:** The engine will run without the vacuum pump installed, but in that case, there would be no oil circulation in the engine since the oil pump shaft has no gear to the camshaft. So, you should never run the engine without the vacuum pump installed. Refer to Section 6H for additional information on vacuum pumps.

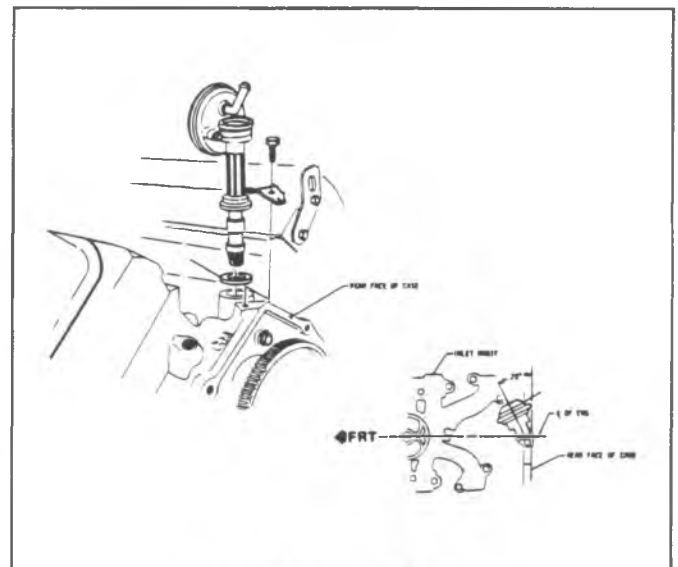

Fig. 6E3-9--Vacuum Pump

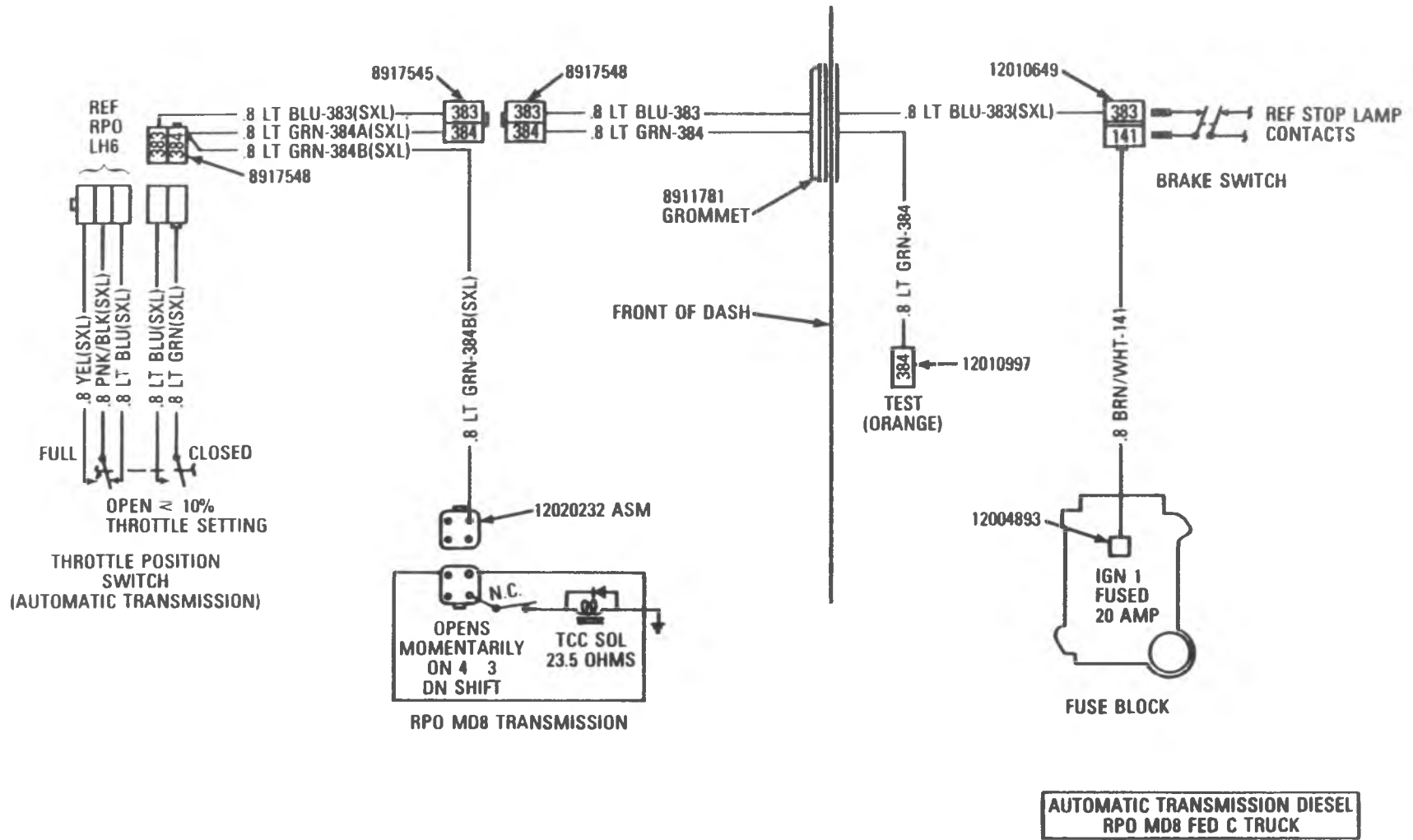
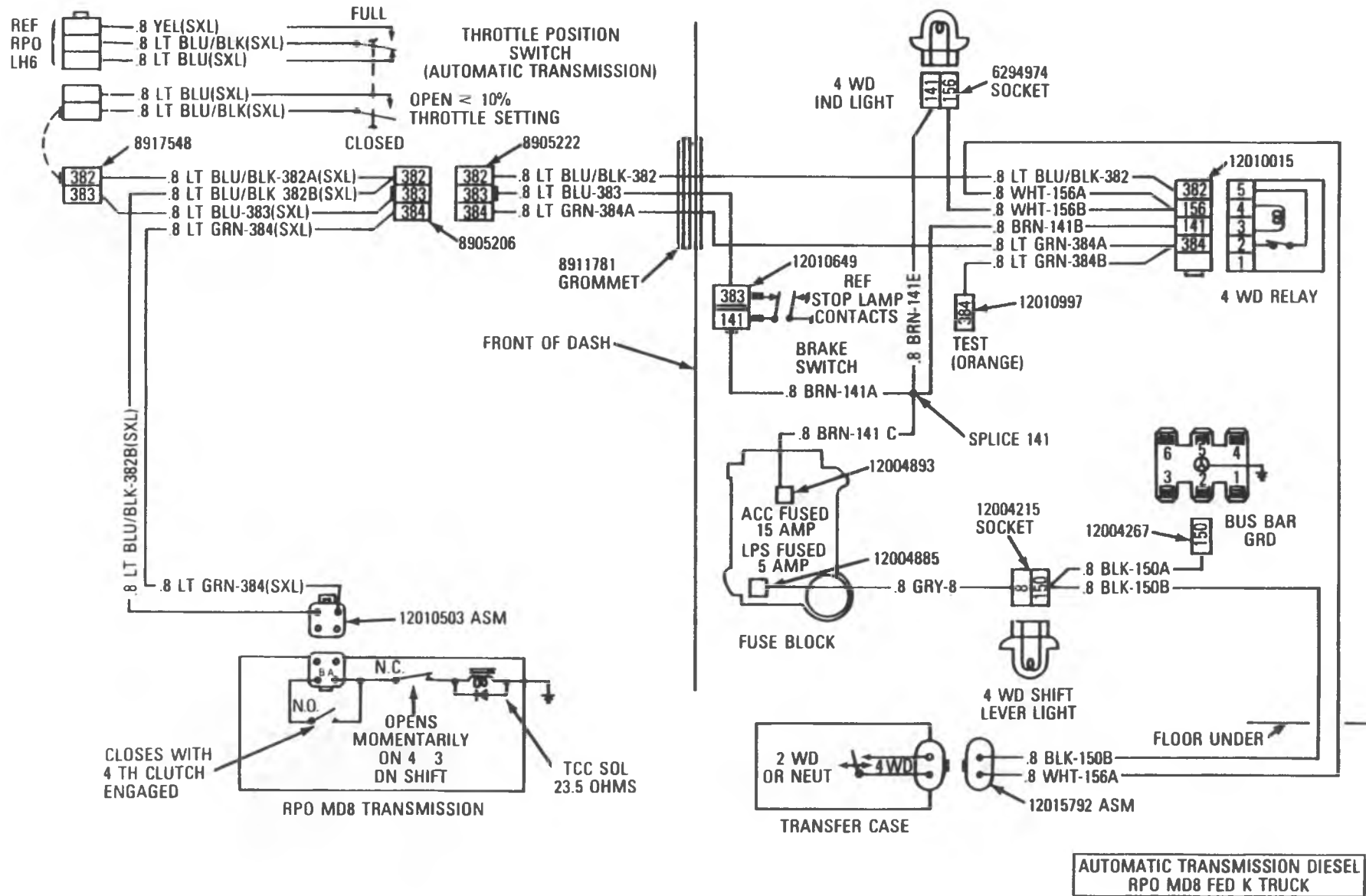
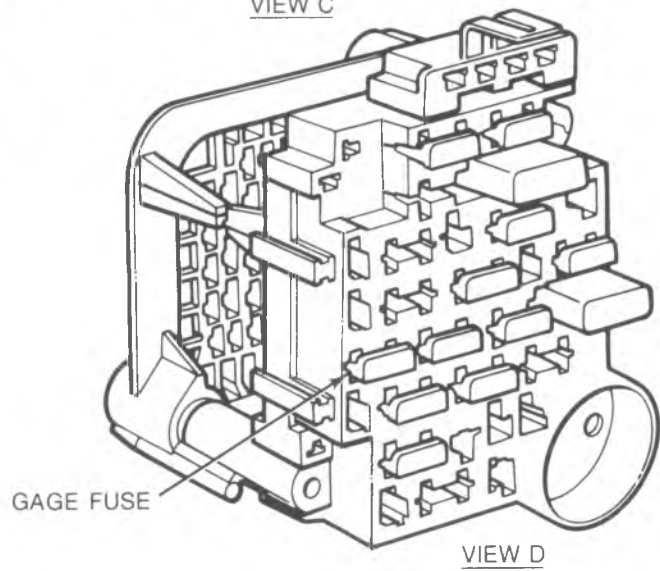
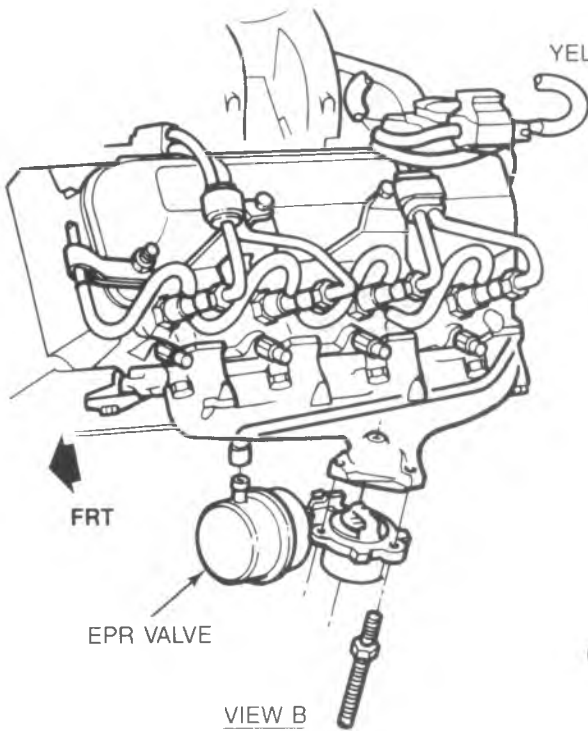
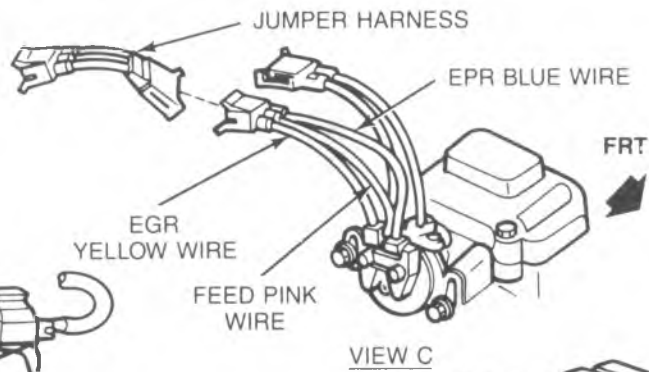
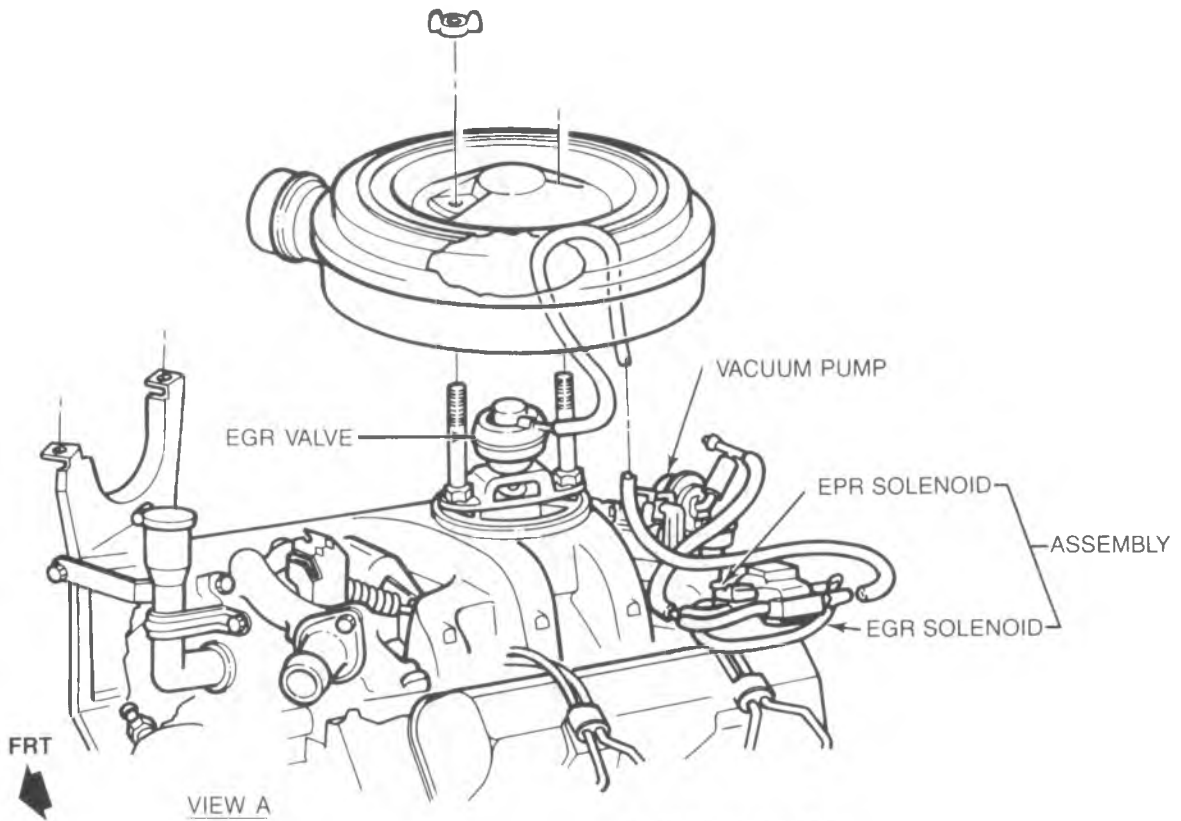

Fig. 6E3-10-Wiring Diagram T.C.C. MD-8 C Truck

Fig. 6E3-11--Wiring Diagram T.C.C. MD-8 K Truck







## SECTION 6F

# ENGINE EXHAUST SYSTEM

### GENERAL DESCRIPTION

The Exhaust System is suspended by hangers attached to the frame members.

Annoying rattles and noise vibrations in the Exhaust System are usually caused by misalignment of parts. When aligning the system, leave all bolts or nuts loose until all parts are properly aligned, then tighten, working from front to rear.

When replacing a muffler, the tailpipe(s) should also be replaced.

Sealer such as **1051249**, or equivalent, should be used at all clamped joint connections.

**NOTICE:** When jacking or lifting vehicle from frame side rails, be certain lift pads do not contact catalytic converter as damage to converter will result.

### CATALYTIC CONVERTER

The catalytic converter is an emission control device added to a gasoline engine light duty emission exhaust system to reduce hydrocarbon and carbon monoxide pollutants from the exhaust gas stream (Figs. 6F-1 6F-2). The catalyst in the converter is not serviceable.

**THE CATALYTIC CONVERTER REQUIRES THE USE OF UNLEADED FUEL ONLY.**

Periodic maintenance of the exhaust system is not required; however, if the vehicle is raised for other service, it is advisable to check the general condition of the catalytic converter, pipes and muffler(s).

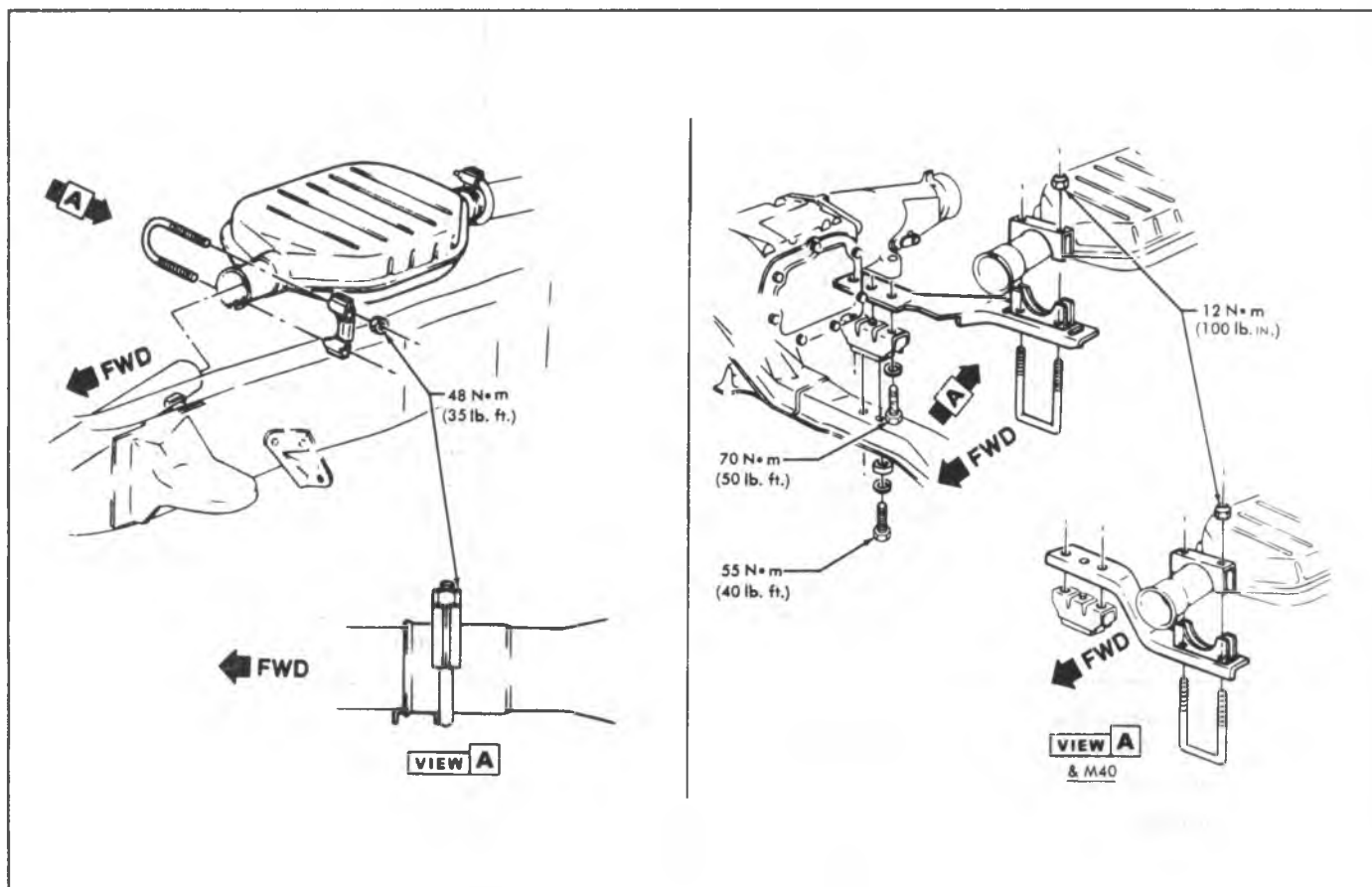

Fig. 6F-1--Catalytic Converter-CK Series

| CONDITION  | POSSIBLE CAUSE   | CORRECTION  |
|--|--|---|
| Leaking Exhaust Gases                                    | Leaks at pipe joints.  | Tighten U-bolt nuts at leaking joints to 30 lb. ft (40 N·m).                                      |
|  | Damaged or improperly installed seals or packing.                  | Replace seals or packing as necessary.  |
|  | Loose exhaust pipe heat tube extension connections.                | Replace seals or packing as required. Tighten stud nuts or bolts to specifications.               |
|  | Burned or rusted out exhaust pipe heat tube extensions.            | Replace heat tube extensions as required.   |
| Exhaust Noises   | Leaks at manifold or pipe connections.                             | Tighten clamps at leaking connections to specified torque. Replace gasket or packing as required. |
|  | Burned or blown out muffler.                                       | Replace muffler assembly.   |
|  | Burned or rusted out exhaust pipe.                                 | Replace exhaust pipe.   |
|  | Exhaust pipe leaking at manifold flange.                           | Tighten attaching bolts nuts to 17 lb. ft. (23 N·m)   |
|  | Exhaust manifold cracked or broken.                                | Replace manifold.   |
|  | Leak between manifold and cylinder head.                           | Tighten manifold to cylinder head stud nuts or bolts to specifications.                           |
| Loss of engine power and/or internal rattles in muffler. | Dislodged turning tubes and or baffles in muffler.                 | Replace muffler.  |
| Loss of engine power.                                    | Imploding (inner wall collapse) of exhaust pipe (except "P" Truck) | Replace exhaust pipe.   |

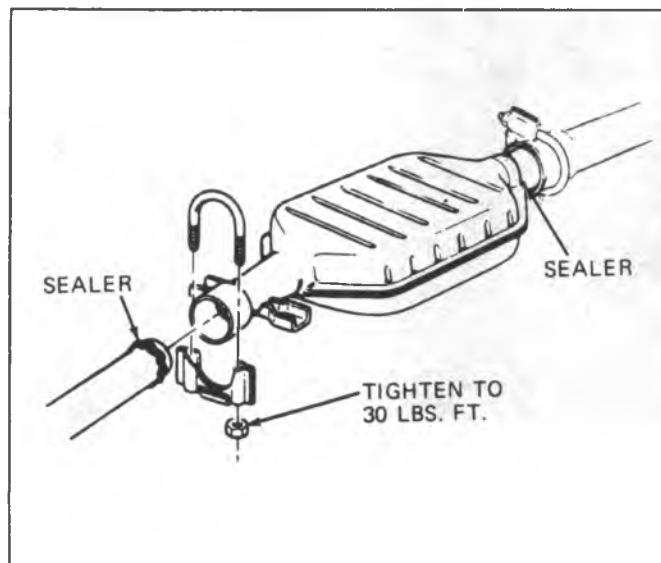

Fig. 6F-2--Catalytic Converter-G Series

## ON-VEHICLE SERVICE

### BOTTOM COVER

If, for any reason, the bottom cover of a single bed converter is torn or damaged, it can be replaced with a repair kit.

### BOTTOM COVER REPLACEMENT

1. Remove bottom cover by cutting close to the bottom outside edge, Fig. 6F-3. Do not remove the fill plug. The depth of the cut must be very shallow to prevent damage to the inner shell of the converter.
2. Remove insulation.

3. Inspect inner shell of the converter for damage. If there is damage in the inner shell, the converter assembly must be replaced.
4. Place new insulation in the replacement cover (Fig. 6F-4). Apply sealing compound, **8998245 or equivalent, all around the cover after the insulation is in position. Apply extra sealer at the front and rear opening for the pipes (Fig. 6F-5).**
5. Install replacement cover on converter (Fig. 6F-6).
6. Install cover retaining channels on both sides of the converter (Fig. 6F-7).
7. Attach 2 clamps over retaining channels at each end of the converter (Fig. 6F-8).



Fig. 6F-3--Removing Bottom Cover

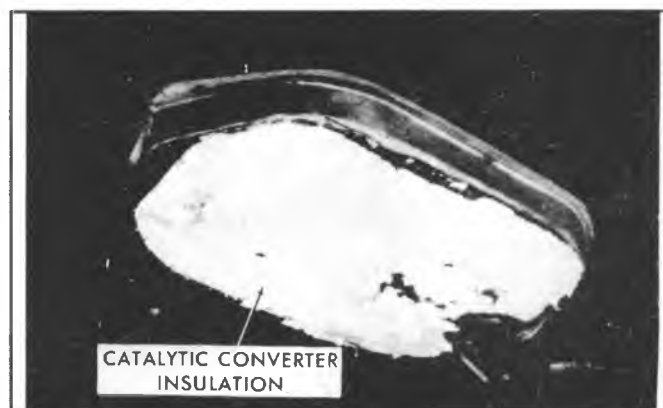

Fig. 6F-4--Catalytic Converter Insulation

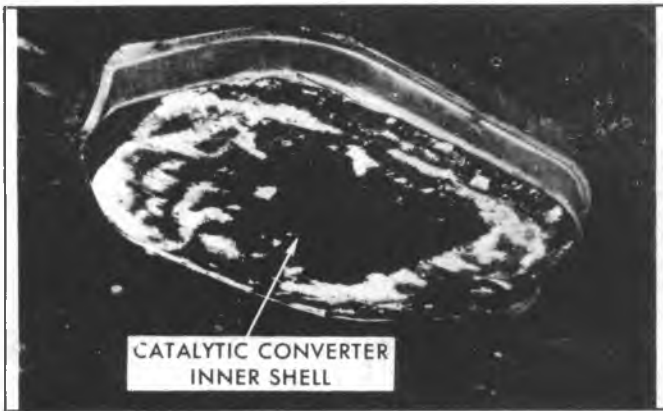

Fig. 6F-5--Catalytic Converter Inner Shell

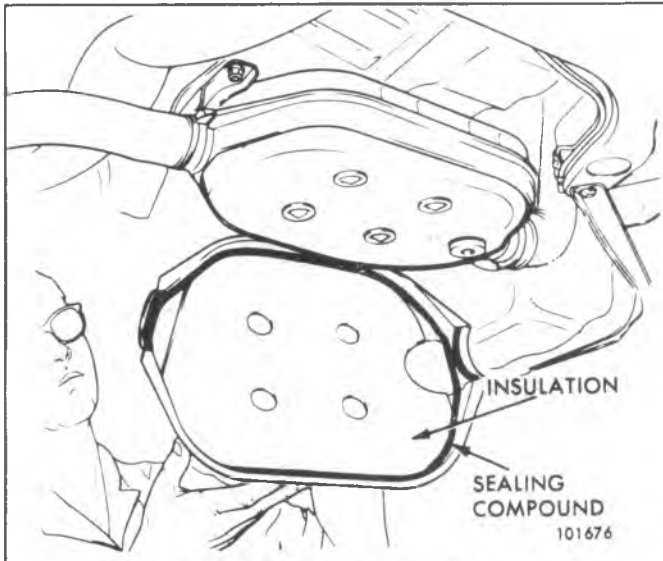

Fig. 6F-6--Installing Bottom Cover Replacement

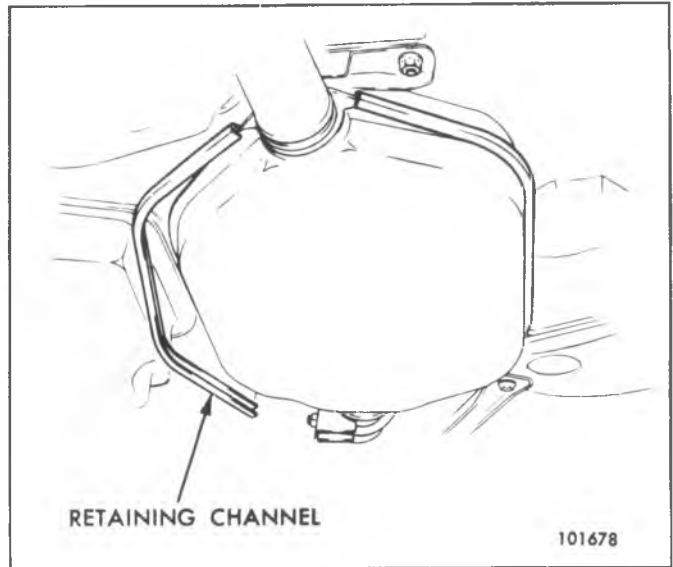

Fig. 6F-7--Installing Bottom Cover Retaining Channels

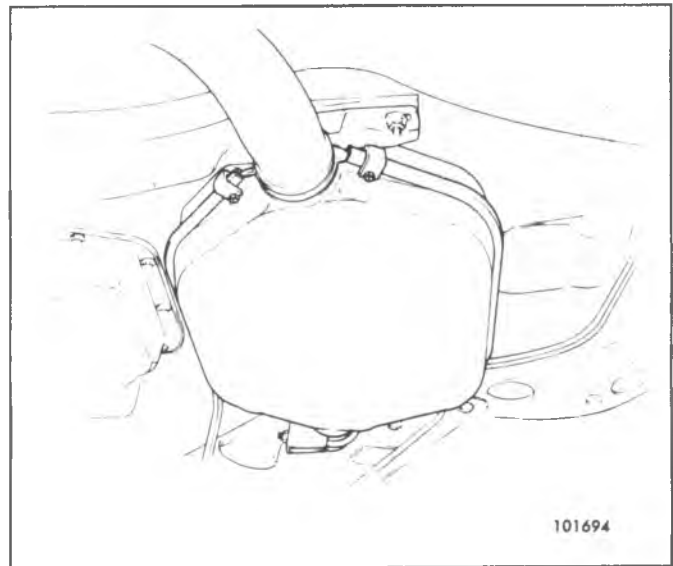

Fig. 6F-8--Installing Bottom Cover Clamps

# SECTION 6H

## VACUUM PUMPS

### CONTENTS

|                           |      |
|---------------------------|------|
| General Description ..... | 6H-1 |
| Gear Driven.....          | 6H-1 |
| Diagnosis .....           | 6H-1 |
| Gear Driven.....          | 6H-1 |
| Unit Repair .....         | 6H-1 |
| Gear Driven.....          | 6H-1 |
| Specifications.....       | 6H-1 |

### GENERAL DESCRIPTION

The vacuum pump is designed to aid the engine in maintaining a proper vacuum level for the power brake system. This is accomplished by using either an electric or a mechanical vacuum pump.

### GEAR DRIVEN VACUUM PUMP

The gear driven vacuum pump is a diaphragm pump which requires no periodic maintenance. It is driven by a cam inside the drive assembly to which it mounts. The drive housing assembly has a drive gear on the lower end which meshes with the camshaft gear in the engine. This drive gear causes the cam in the drive housing to rotate. The drive gear also powers the engine oil lubricating pump.

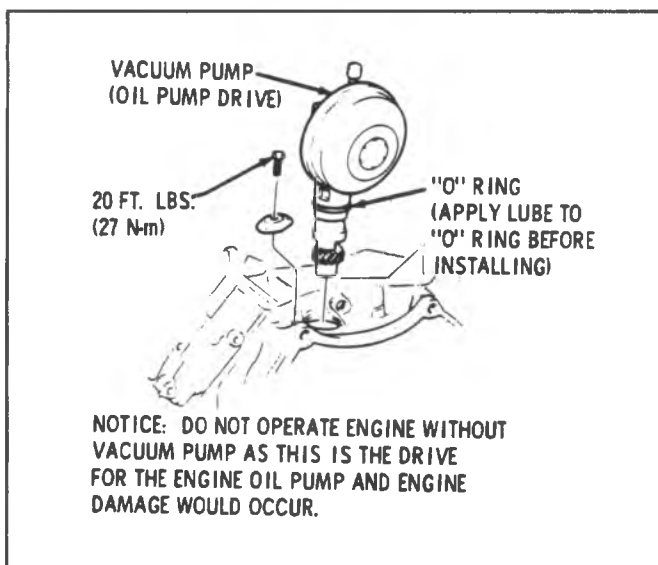

Fig. 6H-1--Gear Driven Vacuum Pump

### DIAGNOSIS

#### GEAR DRIVEN VACUUM PUMP

1. Install hose and vacuum gage to pump, engine running, gage should have reading of 20 inches vacuum minimum.
2. With engine off, vacuum level loss should not drop from 20 inches to 19 inches in less than 1-1/2 seconds.

### UNIT REPAIR

#### GEAR DRIVEN VACUUM PUMP (Figure 6H-1)

##### Removal

1. Remove vacuum hose from vacuum pump inlet.
2. Remove bolt and clamp holding drive assembly to engine block.
3. Carefully lift the pump and drive assembly out of engine block.
4. Cover hole in engine block with a cloth to prevent foreign material falling into engine block.

##### Installation

1. Remove protective cloth from engine.
2. Insert pump and drive assembly in engine, making sure that the gears on the drive assembly mesh with the gears on the engine camshaft.
3. Rotate the pump into position so the bracket and bolt can be installed.
4. Install clamp and bolt.
5. Install vacuum hose to pump.



**SECTION 7**

**CONTENTS**

**AUTOMATIC TRANSMISSION**

350C

400

700-R4

**MANUAL TRANSMISSION**

76MM (3 Spd)

89MM (4 Spd)

117MM (4 Spd)

**CLUTCH**

**TRANSFER CASE**

205

208



11

## SECTION 7A

# AUTOMATIC TRANSMISSION

### CONTENTS

|                                       |      |  |       |
|---------------------------------------|------|--|-------|
| General Description.....              | 7A-1 | Torque Converter Clutch.....           | 7A-8  |
| Diagnosis.....                        | 7A-1 | Leak Checking Converter.....           | 7A-9  |
| Preliminary Checking Procedure.....   | 7A-1 | Converter End Clearance Check.....     | 7A-9  |
| R.T.V. Silicone Sealant.....          | 7A-2 | Stator Assembly Freewheels.....        | 7A-9  |
| Maintenance and Adjustments.....      | 7A-2 | Stator Assembly Remains Locked up..... | 7A-10 |
| Maintenance Schedule.....             | 7A-2 | Checking for Converter Vibration.....  | 7A-10 |
| Fluid Drain Intervals.....            | 7A-2 | Converter Flushing Procedure.....      | 7A-10 |
| Fluid Level and Capacity.....         | 7A-3 | Torque Converter Evaluation.....       | 7A-10 |
| Checking and Adding Fluid (Hot).....  | 7A-3 | General Service Procedures.....        | 7A-11 |
| Checking and Adding Fluid (Cold)..... | 7A-3 | Engine Coolant in Transmission.....    | 7A-11 |
| Changing Fluid.....                   | 7A-4 | Clutch Plate Diagnosis.....            | 7A-11 |
| Adding Fluid to Dry                   |      | Causes of Burned Clutch Plates.....    | 7A-12 |
| Transmission and Converter.....       | 7A-4 | Case Porosity Repair.....              | 7A-12 |
| Manual Linkage.....                   | 7A-4 | Service Methods.....                   | 7A-12 |
| Checking Transmission Mount.....      | 7A-4 | Parts Cleaning and Inspection.....     | 7A-12 |
| T.V. Cable System.....                | 7A-4 | Oil Cooler Pipes.....                  | 7A-13 |
| Diagnosis Procedure.....              | 7A-5 | Cooler Line Flushing.....              | 7A-13 |
| Downshift (Detent) Cable              |      | Shift Linkage Adjustment.....          | 7A-13 |
| System.....                           | 7A-6 | Servo Assembly.....                    | 7A-13 |
| T.V./Detent Cable Adjustment.....     | 7A-6 | Speedometer Driven Gear.....           | 7A-13 |
| Vacuum Modulator.....                 | 7A-7 | Rear Oil Seal.....                     | 7A-15 |
| Vacuum Modulator Diagnosis.....       | 7A-7 | Governor.....                          | 7A-15 |
| Vacuum Diaphragm Check.....           | 7A-7 | Pressure Regulator Valve.....          | 7A-17 |
| Atmospheric Leak Check.....           | 7A-7 | Control Valve Assembly.....            | 7A-17 |
| Load Check.....                       | 7A-8 | Vacuum Modulator.....                  | 7A-17 |
| Sleeve Alignment Check.....           | 7A-8 | T.V./Detent Cable.....                 | 7A-18 |
| Causes of Improper Vacuum             |      | T.C.C. Diagnosis.....                  | 7A-21 |
| At Modulator.....                     | 7A-8 | Transmission.....                      | 7A-18 |
| General Description.....              | 7A-8 | Torque Specification.....              | 7A-22 |
| Torque Converter.....                 | 7A-8 |  |       |

## GENERAL DESCRIPTION

The service procedures contained in this section are common to the automatic transmission sections contained in this manual. Refer to the proper automatic transmission section for specific service procedures.

### DIAGNOSIS

Before diagnosis of any transmission complaint is attempted, there must be understanding of oil checking procedure and what appearance the oil should have. Many times a transmission malfunction can be traced to low oil level or improper reading of dipstick. Due to the transmission fluid that is now being used it may appear to be darker and have a stronger odor. This is normal, and not a positive sign of required maintenance or transmission failure.

Also when the dipstick is removed, it should be noted whether the oil is devoid of air bubbles or not. Oil with air bubbles gives an indication of an air leak in the suction lines, which can cause erratic operation and slippage. Water in the

oil imparts a milky, pink cast to the oil and can cause spewing. Water in the oil can also cause swelling of nylon parts.

### Preliminary Checking Procedure

1. Check and correct oil level (see fluid level and capacity).
2. Road test vehicle to verify transmission problem using all selective ranges, noting discrepancies in operation.
3. If engine performance indicates an engine tune-up is required, this should be performed before road testing is completed or transmission correction attempted. Poor engine performance can result in transmission problems.
4. Check T.V./detent cable adjustment.
5. Check and correct vacuum lines and fittings.
6. Check and correct manual linkage.
7. Install oil pressure gage and compare with pressure readings in the appropriate transmission section.
8. Isolate the unit or circuit involved in the malfunction.

| MODEL       |             |             |        |     |
|-------------|-------------|-------------|--------|-----|
| Application | 125<br>125C | 200<br>200C | 200-4R | 400 |
| Oil Pan     | X           | X           | X      | X   |
| Side Cover  | X           |             |        |     |

Fig. 7A-1 -- R.T.V. Usage Chart

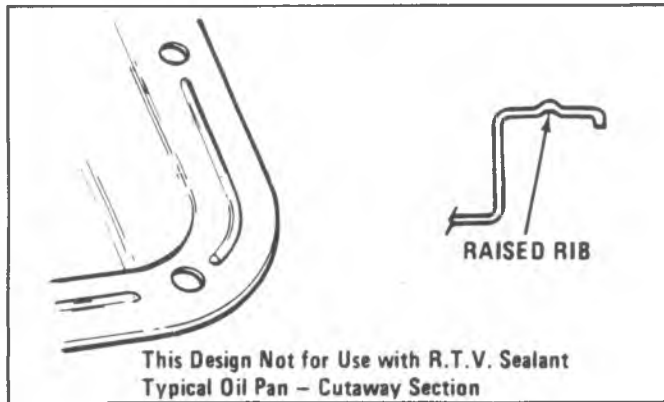

Fig. 7A-2 -- Raised Rib Oil Pan Design

**R.T.V. Silicone Sealant**

Various transmission models may be built with R.T.V. (room temperature vulcanizing) Silicone Sealant in place of some gaskets - i.e., oil pan and side cover. Refer to specific transmission model section for removal procedure if R.T.V. Sealant has been used as a gasket on any part.

**Sealant Application**

1. R.T.V. Sealant is an effective gasket substitute for the following applications, depending on pan design. Refer to Fig. 7A-1.  
If R.T.V. is used on an oil pan or side cover, the flange surface must be either flat or have depressed stiffening ribs. Do not use R.T.V. on pans which have raised stiffening ribs. Refer to Fig. 7A-2.
2. Before applying R.T.V. Sealant, the mating surfaces of both parts must be cleaned with solvent and air dried.
3. Apply a (1/16 in.) bead of R.T.V. Sealant to the part flange and assemble wet. The bead of R.T.V. should be applied around the inside of the bolt holes. If the part has depressed stiffening ribs, the bead of R.T.V. must be installed on the high portion of the surface, not in the groove. Refer to Fig. 7A-3.

**MAINTENANCE SCHEDULE**

The fluid level should be checked at each oil change (see below). When adding or changing fluid, use DEXRON®-II or equivalent automatic transmission fluid. Under normal driving conditions, change transmission fluid every 100,000 miles (160 000 km).

**Fluid Drain Intervals**

The transmission operating temperature resulting from the type of driving conditions under which the vehicle is used, is the main consideration in establishing the proper frequency of transmission fluid changes.

Change the transmission fluid and filter every 15,000 miles (24 000 km) if the vehicle is usually driven under one or more of the following conditions which are considered severe transmission service.

1. In heavy city traffic. Where the outside temperature regularly reaches 90°F (32°C).
2. In very hilly or mountainous areas.
3. Frequent trailer pulling.

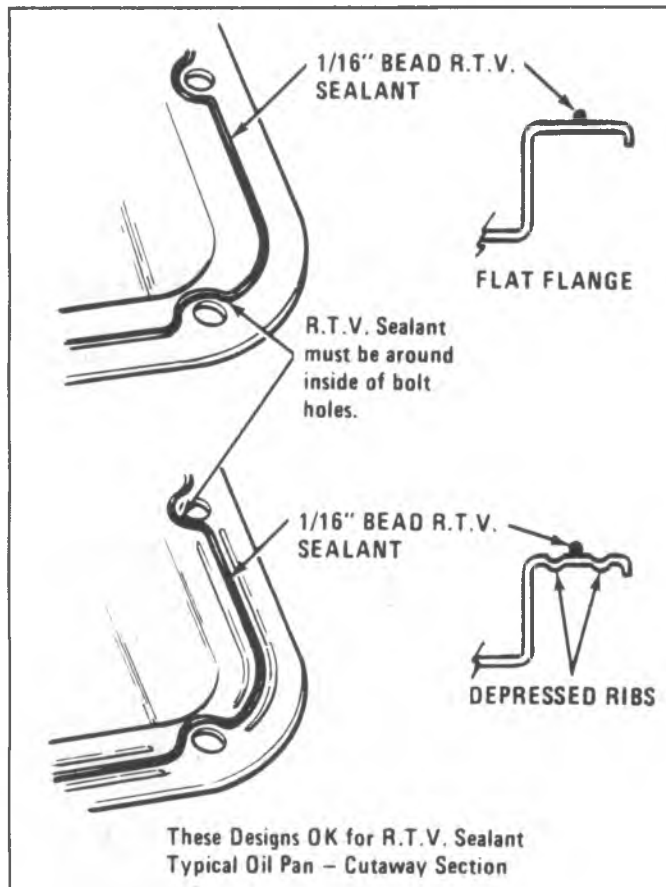

Fig. 7A-3 -- Depressed Ribs and Flat Flange Oil Pan Design

|                                      |                         |
|--------------------------------------|-------------------------|
| <b>AUTOMATIC 350C TRANSMISSION</b>   |                         |
| Pan Removal . . . . .                | 6.3 pts. (3.3 liters)   |
| Overhaul . . . . .                   | 20.0 pts. (9.5 liters)  |
| <b>AUTOMATIC 400 TRANSMISSION</b>    |                         |
| Pan Removal . . . . .                | 9.0 pts. (4.0 liters)   |
| Overhaul . . . . .                   | 22.0 pts. (10.0 liters) |
| <b>AUTOMATIC 700-4R TRANSMISSION</b> |                         |
| Pan Removal . . . . .                | 10.0 pts. (4.7 liters)  |
| Overhaul . . . . .                   | 23.0 pts. (10.9 liters) |

Fig. 7A-4--Transmission Fluid Capacity

- Commercial use, such as taxi, police car, or delivery service.

If the vehicle is not used under any of these conditions, change the fluid and filter every 100,000 miles (160 000 km).

**Fluid Level and Capacity**

To bring fluid level from ADD mark to FULL mark requires one pint (.5 liters) of fluid. Fluid level should be checked at every engine oil change.

Fluid level should be to FULL Mark with transmission fluid at normal operating temperature 200°F (93°C). With fluid at room temperature, 70°F (21°C) level will be between the two dimples on the dipstick. The normal operating temperature is obtained only after at least 15 miles (24 km) of highway type driving.

**Checking and Adding Fluid (Transmission at Operating Temperature)**

The automatic transmission is designed to operate at the "FULL HOT" mark on the dipstick at normal operating temperatures of 190° - 200°F (88°C - 93°C) and should be checked under these conditions. The normal operating temperature is obtained only after at least 15 miles of highway type driving.

To determine proper level, proceed as follows:

- Park vehicle on level surface and apply parking brake and block vehicle wheels.
- With the selector lever in the PARK position, start engine. DO NOT RACE ENGINE. Move selector lever through each range.
- Immediately check fluid with the selector lever in PARK, engine running at SLOW IDLE and the car on a LEVEL surface. The fluid level on the dipstick should be at the "FULL HOT" mark. Recheck fluid 1 to 3 minutes after adding fluid, engine running.

- If additional fluid is required, add sufficient fluid to bring to the "FULL HOT" mark on the dipstick.

**Checking and Adding Fluid (Transmission at Room Temperature 65° to**

**85°F, 18° to 29°C)**

Automatic transmission are frequently overfilled because the fluid level is checked when the fluid is cold and the dipstick indicates fluid should be added. However, the low reading is normal since the level will rise as the fluid temperature increases. A level change of over 19.05mm (3/4") will occur as fluid temperature rises from 60° to 180°F (16° to 82°C) (Figure 7A-5).

Overfilling can cause foaming and loss of fluid through the vent. Slippage and transmission failure can result.

Fluid level too low can cause slipping, particularly, when the transmission is cold or the vehicle is on a hill.

Check the transmission fluid level with the engine running, the shift lever in park, and the vehicle level.

If the vehicle has recently been operated for an extended period at high speed or in city traffic in hot weather or the vehicle is being used to pull a trailer, an accurate fluid level cannot be determined until the fluid has cooled down, usually about 30 minutes after the vehicle has been parked.

Remove the dipstick and touch the transmission end of the dipstick cautiously to find out if the fluid is cool, warm or hot.

Wipe it clean and re-insert until cap seats. Remove dipstick and note reading.

- If the fluid feels cool, about room temperature, (65° to 85°F or 18° to 29°C), the level should be between the two dimples below the "add" mark.
- If it feels warm, the level should be close to the "ADD" mark (either above or below).
- If it feels hot (cannot be held comfortably), the level should be between the "ADD" and "FULL" marks.

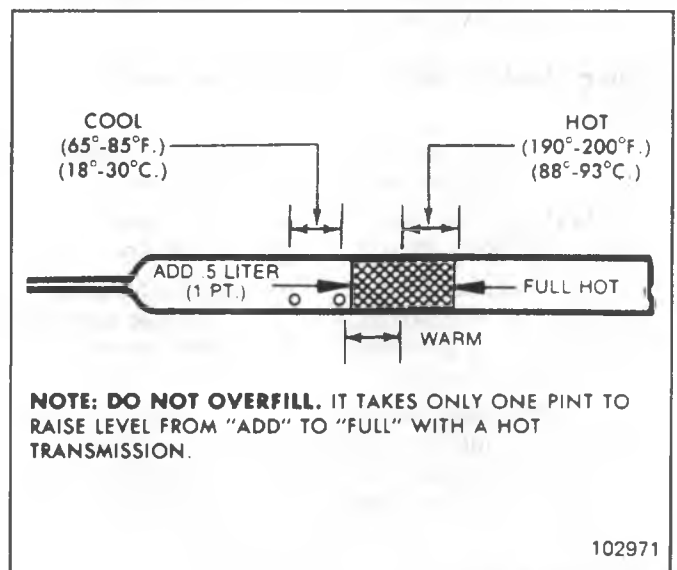

Fig. 7A-5 -- Transmission Dipstick

## Changing Fluid

1. Raise vehicle.
2. With drain pan placed under transmission oil pan, remove oil pan attaching bolts from front and side of pan.
3. Loosen rear pan attaching bolts approximately four (4) turns.
4. Carefully pry transmission oil pan loose with screwdriver, allowing fluid to drain.
5. Remove remaining bolts and remove oil pan and gasket.
6. Drain fluid from oil pan. Clean pan with solvent and dry thoroughly with clean compressed air.
7. If required, remove screen/filter-to-valve body bolts. Remove screen/filter and gasket.
8. Thoroughly clean screen assembly in solvent and dry thoroughly with clean compressed air. Paper or felt type filters should be replaced.
9. Install as required, a new gasket or "O" ring onto the screen/filter assembly. Lubricate "O" rings with petrolatum. If required, install screen/filter attaching bolts and torque bolts as specified in each transmission section.
10. Install new gasket on oil pan and install oil pan. Torque attaching bolts as specified in each transmission section.
11. Lower vehicle and add the proper amount of DEXRON®-II automatic transmission fluid or its equivalent through filler tube (Figure 7A-4).
12. With selector lever in PARK position, apply parking brake, start engine and let idle (carburetor off fast idle step.) DO NOT RACE ENGINE.
13. Move selector lever through each range and, with selector lever in PARK range, check fluid level.
14. Add additional fluid to bring level between the dimples on the dipstick (cool level).

## Adding Fluid To Fill Dry Transmission and Converter

In cases of transmission overhaul, when a complete fill is required, including converter, proceed as follows:

1. Add the proper amount of transmission fluid through filler tube. See Figure 7A-4 for proper amount.
2. With manual control lever in park (P) position, depress accelerator to place carburetor on fast idle cam. DO NOT RACE ENGINE. Move manual control lever through each range.
3. Check fluid level with selector lever in park (P), engine running at idle (1-3 minutes) and vehicle on LEVEL surface and add additional fluid to bring level to a point between the two dimples on the dipstick. Do not overfill.

## Manual Linkage

Manual linkage should be adjusted so that the engine will start in the Park and Neutral positions only.

With the selector lever in the Park position, the parking pawl should freely engage within the rear/reaction internal gear lugs or output ring gear lugs. The pointer on the

indicator quadrant should line up properly with the range indicators in all ranges.

If the linkage is not adjusted properly, an internal leak could occur at the manual valve which could cause a clutch and/or band failure.

**CAUTION: With the selector lever in the "Park" position, the parking pawl should freely engage within the rear/reaction internal gear lugs or output ring gear lugs and prevent the vehicle from rolling, which could cause personal injury.**

## Checking Transmission Mount

Raise vehicle. Push up and pull down on transmission tailshaft while observing transmission mount. If rubber separates from metal plate of mount or if tailshaft moves up but not down (mount bottomed out) replace mount. If there is relative movement between a metal plate of mount and its attaching point, tighten screws or nuts attaching mount to transmission or crossmember.

## T.V. Cable System

The T.V. Cable used with the Automatic 700-4R transmission should not be thought of as an automatic downshift cable. The T.V. cable used on the Automatic 700-R4 controls line pressure, shift points, shift feel, part throttle downshifts and detent downshifts. The function of the cable is similar to the combined functions of the vacuum modulator and the downshift (detent) cable used on 350C transmission.

The T.V. cable operates the throttle lever and bracket assembly (Figures 7A-6 and 7A-7).

The Throttle Lever and Bracket Assembly serves two (2) basic functions:

1. The primary function of this assembly is to transfer the carburetor throttle plate movement to the T.V. plunger in the control valve assembly as related by the T.V. cable and linkage (Figure 7A-6). This causes T.V. pressure and line pressure to increase according to engine throttle opening and also controls part throttle and detent downshifts. The proper adjustment of the T.V. cable is based on the T.V. plunger being fully depressed to flush with the T.V. bushing at engine wide open throttle.
2. The second function of the assembly involves the T.V. exhaust valve lifter rod, spring and the T.V. exhaust ball. The function of this system is to prevent the transmission from operating at low (idle position) pressures, if the T.V. cable should become broken or disconnected. If the cable is not connected or broken, the T.V. lifter rod will not move from its normal, spring loaded, up position which holds the T.V. exhaust check ball off its seat. The T.V. lifter rod will drop down to allow the T.V. exhaust ball to seat only if the cable is broken, disconnected or extremely out of adjustment. With the transmission pan removed, it should be possible to pull down on the T.V. exhaust valve lifter rod and the springs should return the rod to its normal up position. If the throttle lever and bracket assembly or lifter rod binds or sticks so that the T.V. lifter rod cannot lift the exhaust ball off its seat, high line pressures and delayed upshifts will result. The normal shape of the T.V. lifter rod is shown in Figure 7A-9. The right angle leg must not be bent to any other angle or it will not function properly.

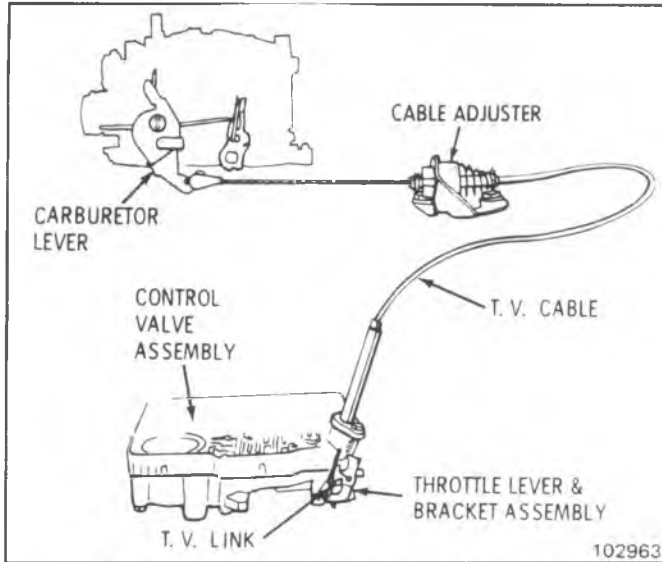

Fig. 7A-6--Throttle Valve (T.V.) Cable and Linkage

**Diagnosis Procedure**

If the T.V. cable is broken, sticky, misadjusted or incorrect part for the model, the vehicle may exhibit various malfunctions.

Sticking or binding T.V. linkage can result in delayed or full throttle shifts. The T.V. cable must be free to travel to the full throttle position and return to the closed throttle position without binding or sticking.

Some binding or sticking of the T.V. cable and associated parts may only occur with the engine running and will not be noted or obtained with the engine off.

Inspection of the T.V. linkage for sticking or binding should be made with engine running at idle speed, with the transmission selector in Neutral and the parking brakes set. Pull the T.V. cable full travel through the cable terminal and then release the cable; it should return to the closed throttle position against the cable terminal (Figure 7A-10). If the T.V. cable sticks, and remains ahead of the cable terminal (Figure 7A-11), it may be caused by one or more of the following:

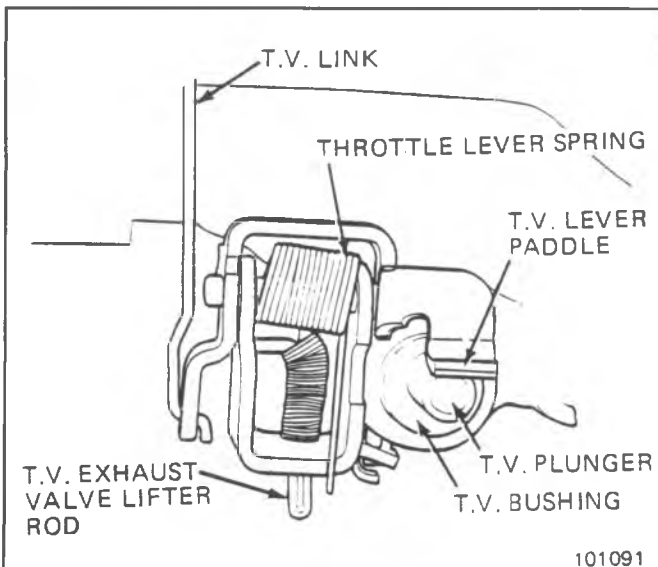

Fig. 7A-7--Throttle Lever and Bracket Assembly

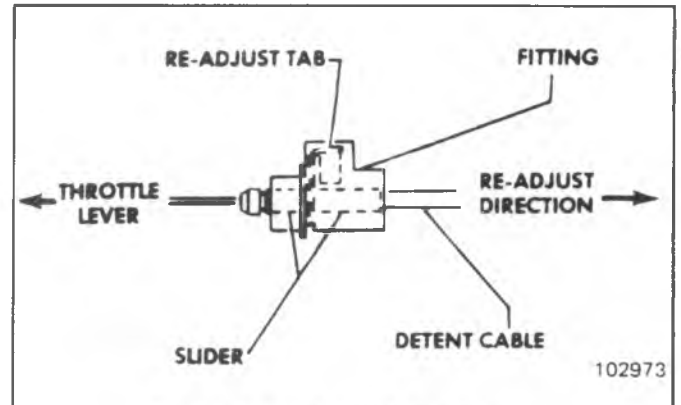

Fig. 7A-8--T.V. Cable (Self Adjusting)

1. Sharp bends or a damaged T.V. cable housing. Correct by rerouting the cable or replace it if required.
2. Sharp end or burr on the T.V. link, dragging in the T.V. cable housing. Correct by making end smooth, using a file or stone. **DO NOT SHORTEN LINK.**
3. Bent T.V. link. Correct by straightening or replace as required.
4. Misalignment of the throttle lever and bracket assembly on the coiled pin in the control valve assembly (Figure 7A-12).
5. Damaged or binding throttle lever and bracket assembly. Correct by straightening or replace as required.
6. Throttle lever spring unhooked or damaged. Correct by assembling the spring properly or replace the throttle lever and bracket assembly as required.

If the T.V. cable is adjusted too long, it may result in one of the two following conditions:

- a. Early and slipping shifts and/or no detent downshifts.
- b. Delayed or full throttle shifts by causing the transmission to operate in the high pressure mode. The transmission senses a malfunction of the T.V. cable and associated parts; and to prevent burning the clutches and band due to low line pressures, it will go into the high pressure mode. Line pressures checked under the minimum T.V. conditions in Neutral and Drive will be in the range of the "full" T.V. pressures if the transmission is in high pressure mode. The complaint could be

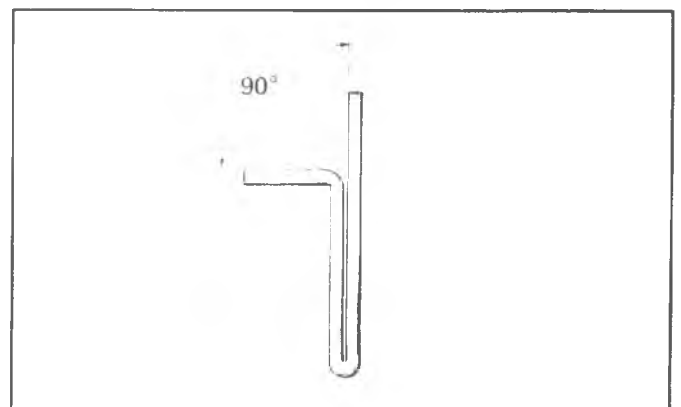

Fig. 7A-9--Throttle Valve Lifter Rod

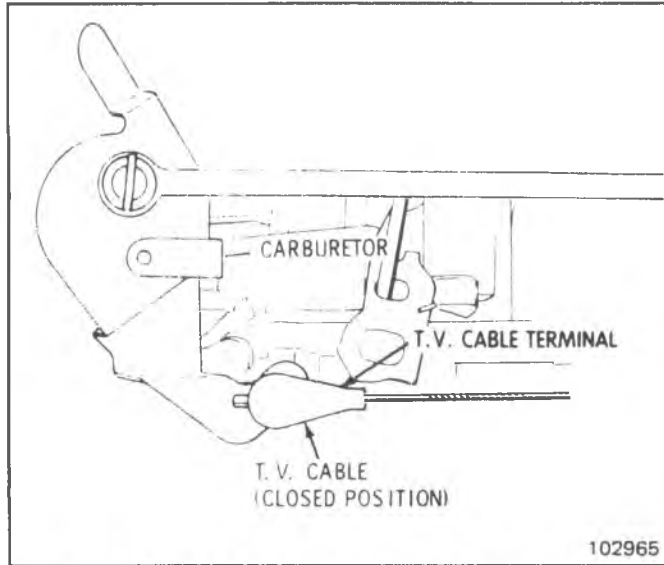

Fig. 7A-10--T.V. Cable at Carburetor Lever (Typical)

described as no upshifts, delayed or sharp upshifts.

### Downshift (Detent) Cable System for 350C Transmissions

The detent valve is activated by the downshift (detent) cable which is connected to the carburetor linkage. When the throttle is half open, the detent valve is actuated, causing a part throttle downshift at speeds below 50 mph (80 km/h). When the throttle is fully opened, the detent valve is actuated causing the transmission to downshift. The 3-1 detent downshift may be obtained when vehicle speed is approximately 6 to 12 mph (9 to 19 km/h) below the maximum throttle 1-2 upshift point. The 3-2 detent downshift may be obtained when vehicle speed is approximately 4 to 8 mph (6 to 13 km/h) below the maximum throttle 2-3 upshift point.

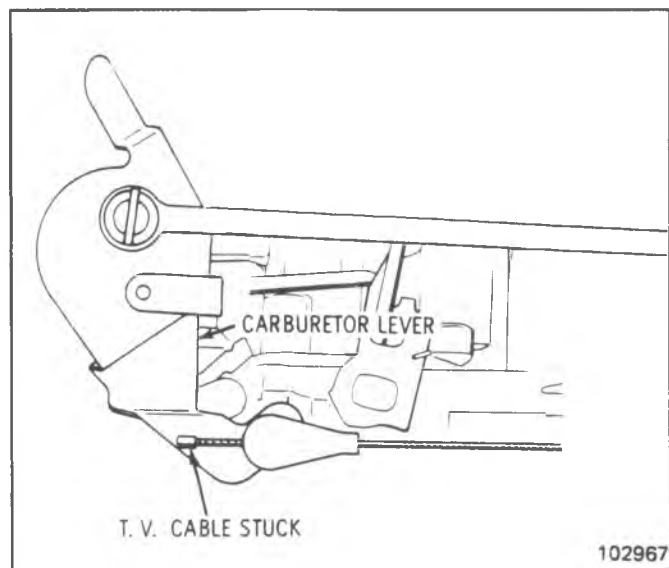

Fig. 7A-11--Sticking T.V. Cable

### Adjustment Procedure for T.V. and Detent Cable

#### Preliminary Checks

1. Check transmission oil level and correct as required.
2. Be sure engine is operating properly and brakes are not dragging.
3. Check for correct cable, according to the parts catalog.
4. Check that the cable is connected at both ends.
5. Adjust the cable as follows:

#### Adjusting Cable (Diesel Engine Only)

1. Stop Engine.
2. Remove cruise control rod (if so equipped).
3. Disconnect transmission T.V. or detent cable terminal from throttle assembly.
4. Loosen lock nut on pump rod and shorten several turns.
5. Rotate the lever assembly to the full throttle position and hold.
6. Lengthen pump rod until the injection pump lever contacts the full throttle stop.
7. Release the lever assembly and tighten pump rod lock nut.
8. Remove the pump rod from the lever assembly.
9. Reconnect the transmission T.V. or detent cable terminal to throttle assembly.
10. Depress and hold the metal re-adjust tab on the cable upper end. Move the slider through the fitting in the direction away from the lever assembly until the slider stops against the fitting.
11. Release the tab, rotate the lever assembly to the full throttle stop and release the lever assembly.
12. Reconnect the pump rod (and cruise control throttle rod if so equipped).
13. If equipped with cruise control, adjust the servo throttle rod to minimum slack (engine off) then put clip in first free hole closest to the bellcrank, but

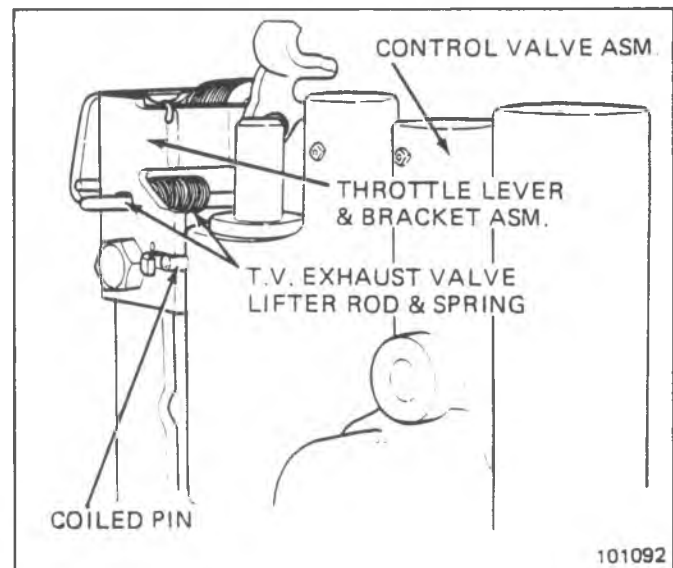

Fig. 7A-12--Alignment of Throttle Lever and Bracket Assembly

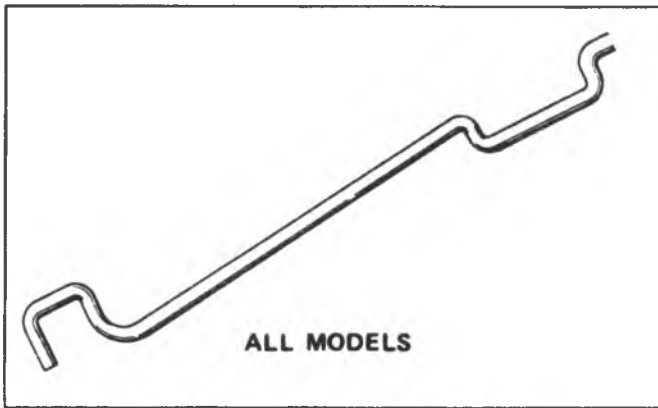

Fig. 7A-13--Throttle Lever to Cable Link within the servo bail.

**Adjusting Self-Adjusting Type Cable (Gas Engine)**

1. Stop engine.
2. Depress re-adjust tab. Move slider back through fitting in direction away from throttle body until slider stops against fitting.
3. Release re-adjust tab.
4. Open carburetor lever to "full throttle stop" position to automatically adjust cable. Release carburetor lever.
5. Check cable for sticking and binding.

Road test vehicle - if OK, return to owner. If delayed or only full throttle shifts still occur, proceed with the following:

Remove the oil pan and inspect the throttle lever and bracket assembly (See Figure 7A-12). Check that the T.V. exhaust valve lifter rod is not distorted and not binding in the control valve assembly or spacer plate. The T.V. exhaust check ball must move up and down as the lifter does. Also, be sure lifter spring holds the lifter rod up against the bottom of the control valve assembly. Make sure T.V. plunger is not stuck. Inspect transmission for correct throttle lever to cable link (See Figure 7A-13).

If the T.V. cable is adjusted too short or not adjusted at all, it will result in raising the line pressure and shift points. It may also limit the carburetor opening to prevent full throttle operation.

**DETENT DOWNSHIFT SWITCH (Fig. 7A-14)**

**Adjustment (400)**

1. Preset switch by pressing the plunger as far forward as possible.
2. Press accelerator pedal down to a wide open throttle position and the switch will self adjust.

**Vacuum Modulator System**

A vacuum modulator is used to automatically sense any change in torque input to the transmission. The vacuum modulator transmits this signal to the pressure regulator, which controls line pressure, so that all torque requirements of the transmission are met and smooth shifts are obtained at all throttle openings.

**Vacuum Modulator Diagnosis**

A failed vacuum modulator can cause one or more of the following complaints.

1. Harsh upshifts and downshifts.
2. Delayed upshifts.
3. Soft upshifts and downshifts.
4. Slips in low, drive and reverse.
5. Transmission overheating.
6. Engine burning transmission oil.

If any one of the above complaints are encountered, the modulator must be checked.

**Vacuum Diaphragm Check**

Turn modulator so vacuum line stem points downward. If transmission oil comes out, the vacuum diaphragm is bad.

Gasoline and/or water vapor may settle in the vacuum side of the modulator. If this is found in a vehicle which may be exposed to 10°F (-12°C) temperatures or below, the modulator must be changed.

Check solution that comes out of the modulator for evidence of lubricity. If the solution does not have the feel of oiliness, it can be assumed the solution is a mixture of gas and/or water. The only way transmission oil can be on the vacuum side of the modulator is by a leak in the vacuum diaphragm.

If oil is found, the modulator must be replaced. If oil is not found in the vacuum side of the modulator, but the transmission oil level is continually low, and no external leaks are found, there is a possibility that a pin hole leak exists in the diaphragm and the modulator should be replaced.

**Atmospheric Leak Check**

1. Apply a liberal coating of soap bubble solution to the vacuum connector pipe seam, the crimped upper to lower housing seam.
2. Using a short piece of rubber hose, apply air

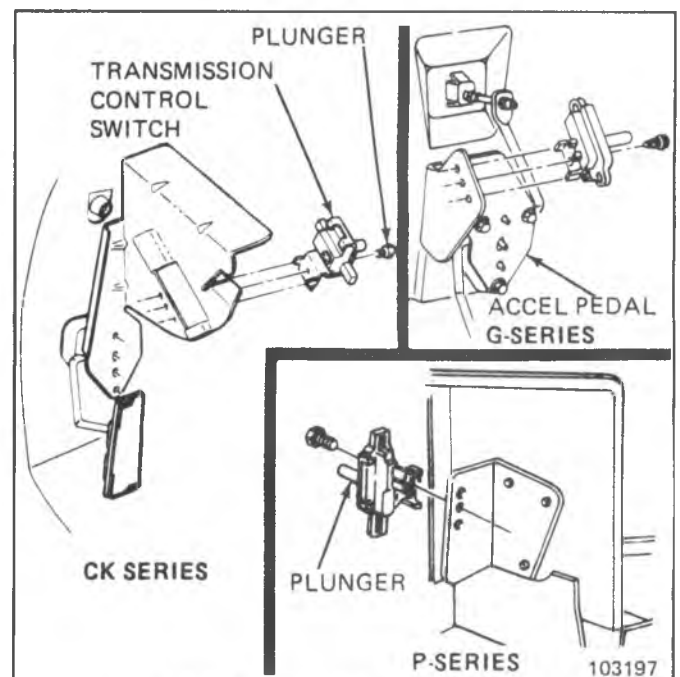

Fig. 7A-14--Detent Downshift Switch



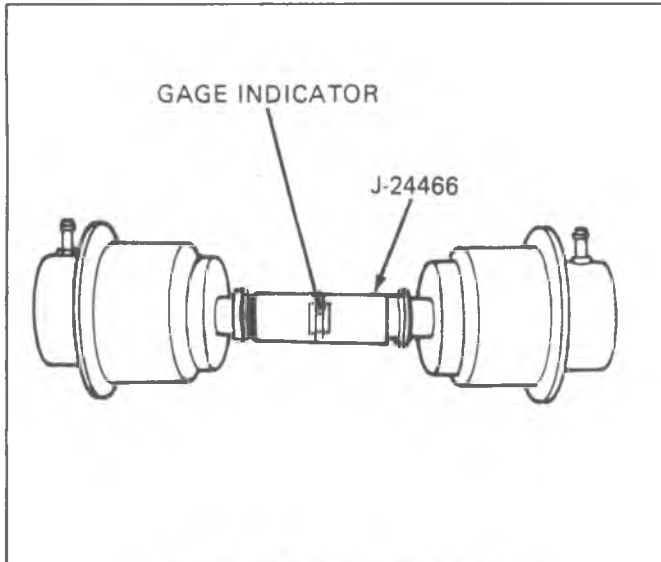

Fig. 7A-15--Checking Modulator

pressure to the vacuum pipe by blowing into the tube and looking for bubbles. If bubbles appear, replace the modulator. Do not use any method other than human lung power for applying air pressure, as pressures over 6 psi may damage the modulator.

### Load Check

This check is made using an available tool, J-24466. The gage compares the load of a known good modulator with a modulator being checked.

1. Install the modulator that is known to be acceptable on either end of the gage.
2. Install the modulator in question on the opposite end of the gage (Figure 7A-15).
3. Holding the modulators in a horizontal position, bring them slowly together under pressure. If the modulator in question is bad, the gage line will remain blue. If the modulator is good, the gage line will be white. When making the comparison, make sure that both modulators are of the same type. The part numbers are stamped on the dome of the modulator.

### Sleeve Aignment Check

Roll the main body of the modulator on a flat surface and observe the sleeve for concentricity to the can. If the sleeve is concentric and the plunger is free, the modulator is acceptable.

If the modulator passes the above checks, the following items should also be checked as a possible cause of the problem.

1. Check freeness of modulator valve in transmission case.
2. Check the vacuum line from the manifold to modulator for holes, cracks or dents. Check the rubber hose connection at the modulator and at the intake manifold for leaks.

### Causes of Improper Vacuum At Modulator

1. Engine.
  - a. Tune up.

- b. Loose vacuum fittings or improperly routed hoses/lines.
  - c. Vacuum operated accessory leak (hoses, vacuum valve, etc.).
  - d. Engine exhaust system restricted.
  - e. Diesel - Vacuum Regulator Valve adjustment (See Section 6C6).
2. Vacuum line to modulator.
    - a. Leak.
    - b. Loose fitting.
    - c. Restricted orifice or incorrect orifice size.
    - d. Carbon build up at modulator vacuum fitting.
    - e. Pinched line.
    - f. Grease in pipe (delayed or no upshift-cold).

## GENERAL DESCRIPTION

### Torque Converter

The torque converter is filled with oil and is attached to the engine crankshaft by a flex plate and always rotates at engine speed.

The torque converter couples the engine to the planetary gears through oil and provides hydraulic torque multiplication when required.

The 3-element torque converter consists of a pump or driving member, a turbine or driven member, and a stator assembly.

### Torque Converter Clutch

The Torque Converter Clutch Assembly consists of a 3-element torque converter with the addition of a converter clutch. The converter clutch is splined to the turbine assembly, and when operated, applies against the converter cover providing a mechanical direct drive coupling of the engine to the planetary gears.

Converter clutch operation determined by a series of controls and by drive range selection. The transmission must be in drive range, and the vehicle must have obtained a preset speed depending on engine and transmission combination.

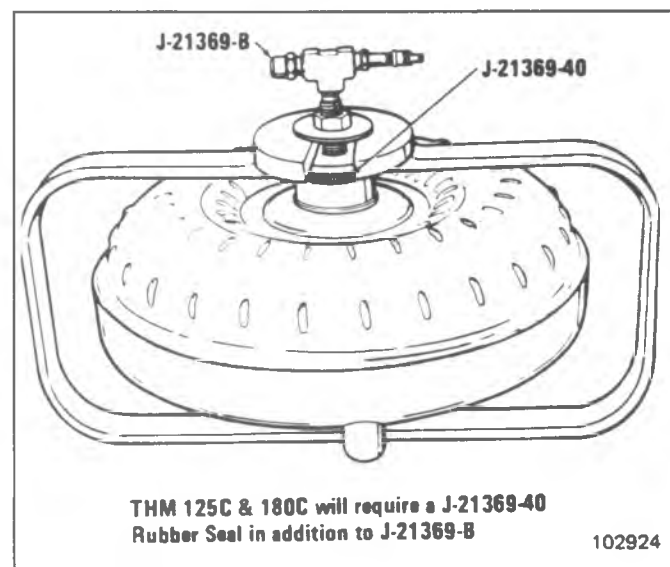

THM 125C & 180C will require a J-21369-40 Rubber Seal in addition to J-21369-B

102924

Fig. 7A-16--Installing Tool J-21369

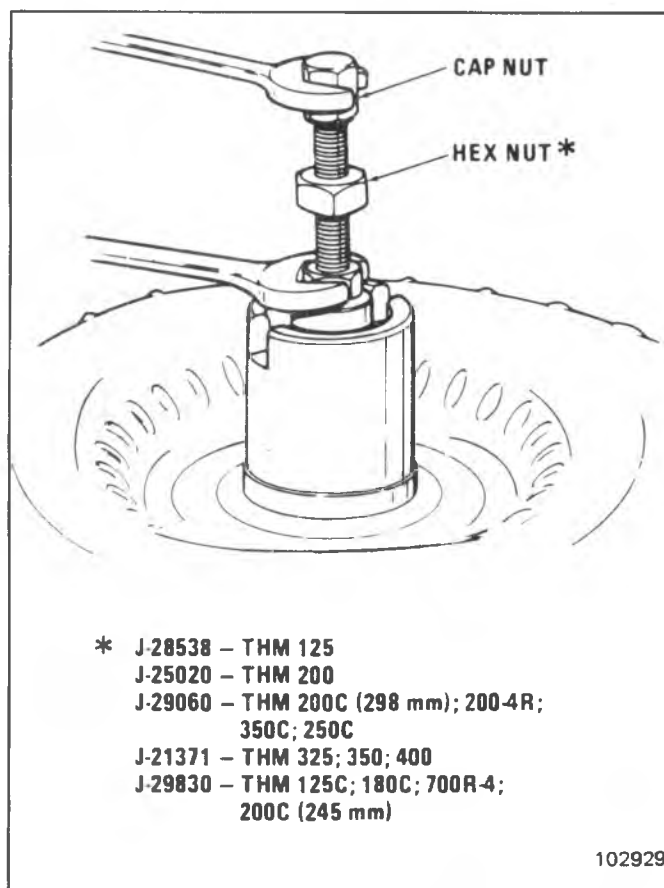

Fig. 7A-17--Installing Tools

**DIAGNOSIS**

**Leak Checking Converter**

1. Check converter for leaks as follows:
  - a. Install J-21369-2 and J-21369-6 and tighten hex nut on J-21369-2 (Figure 7A-16).
  - b. Fill converter with air; 551 kilopascals (80 psi).
  - c. Submerge in water and check for leaks.

**CAUTION:** After leak testing, bleed pressurized air from J-21369-2 before removing tools from converter. Escaping high pressure may cause personal injury.

2. Check converter hub surfaces for signs of scoring or wear.

**Check Converter End Clearance as Follows:**

1. Fully release collet end of required end play tool. See Fig. 7A-17.
2. Install collet end of tool into converter hub until it bottoms; then tighten cap nut to 6.7 N·m (5 ft. lbs.). (Figure 7A-17).

**For THM 400 converter**

- a. Install tool J-21371-3 and tighten hex nut to 4.0 N·m (3 ft. lbs.) Figure 7A-18).
- b. Install dial indicator and set it at zero while its plunger rests on the cap nut of tool (Figure 7A-18).

- c. Loosen hex nut while holding cap nut stationary. With hex nut loose and holding tool J-21371-3 firmly against the converter hub, the reading obtained on the dial indicator will be the converter end clearance. End clearance should be less than 0.127 mm (0.050"). If the end clearance is greater, the converter must be replaced (Figure 7A-18).

**For all other converters**

- a. Install dial indicator J-8001, (Fig. 7A-19) and set it at zero while its plungers rests on the converter.
  - b. Lift up the arm on the tool handle. Converter end clearance should be 0.12mm (0.050"). If the end clearance is greater, the converter must be replaced (Fig. 7A-19).
3. With the transmission in cradle or portable jack, install the converter assembly into the pump assembly, making sure that the converter hub drive slots are fully engaged with the pump drive gear tangs and the converter installed fully towards the rear of the transmission.
 

The converter will be properly installed if the distance is 25.4 mm (1.00") minimum between the engine mounting face of the case and the front face of the converter cover drive straps.
  4. Retain converter with J-21366.

**Converter Stator Operation**

**Stator Assembly Freewheels**

If the stator roller clutch becomes ineffective, the stator assembly freewheels at all times in both directions. With this condition, the vehicle tends to have poor acceleration from a standstill. At speeds above 48 to 56 km/h (30-35 mph), the vehicle may act normal. If poor acceleration problems are noted, it should first be determined that the exhaust system is not blocked, the engine is running properly and the transmission is in first (1st) gear when starting out.

If the engine will freely accelerate to high rpm in Neutral (N), it can be assumed that the engine and exhaust

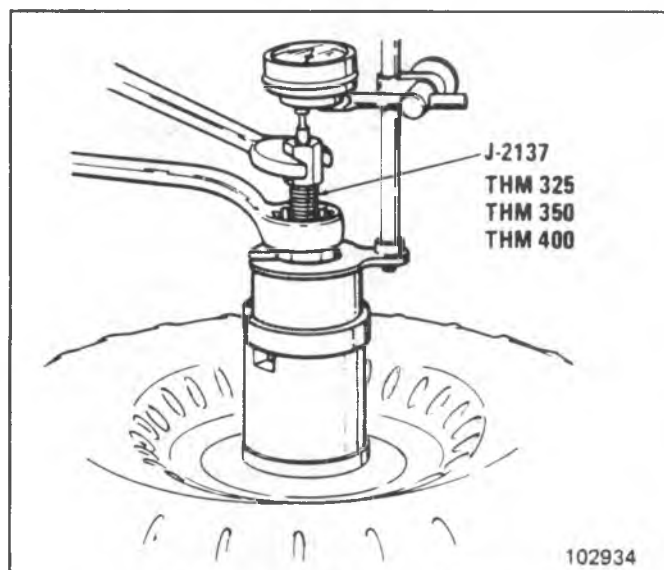

Fig. 7A-18--Checking End Clearance

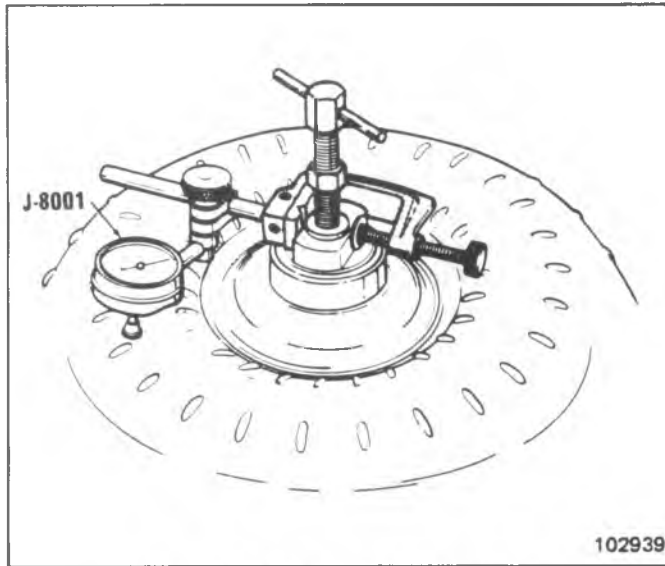

Fig. 7A-19--Checking End Clearance

system are normal.

### Stator Assembly Remains Locked Up

If the stator assembly remains locked up at all times, the engine rpm and vehicle speed will tend to be limited or restricted at high speeds. The vehicle performance when accelerating from a standstill will be normal. Engine overheating may be noted. Visual examination of the converter may reveal a blue color from the overheating that will result.

Under conditions above, if the converter has been removed from the transmission, the stator roller clutch can be checked by inserting a finger into the splined inner race of the roller clutch and trying to turn the race in both directions. The inner race should turn freely in the clockwise direction, but not turn or be very difficult to turn in the counterclockwise direction.

Do not use such items as the pump cover or stator shaft to turn the race as the results may be misleading.

### Checking For Converter Vibration

1. Inspect for missing or loose converter-to-flywheel bolts. Tighten or replace as necessary.
2. Inspect converter for damage or missing balance weights. If the converter is damaged or balance weights are missing, replace the converter.
3. Change position of converter-to-flywheel 120 degrees at a time to cancel out engine and converter unbalance. Recheck in each position for vibration improvements.
4. If the unbalanced condition still exists, leave the converter-to-flywheel in the best balanced position. Install longer flywheel-to-converter bolts adding and removing washers until the best balance is achieved.

Be sure the bolts are not bottoming in the holes. Always rotate the converter by hand after adding washers to check for clearance.

### CONVERTER FLUSHING PROCEDURE (Fig. 20 thru 22)

1. Drill an 11/32" hole in the converter between the two vane extrusions and adjacent to the converter weld seam edge. See Figure 20.

- a. Drill the hole to approximate completion.
- b. Remove the drill bit from the started hole and coat it with grease to hold any metal chips.
- c. Complete drilling the hole at low drill speed.

**NOTICE:** To prevent converter damage, drill at right angles to the surface and sleeve the drill bit so it can enter no deeper than 1/4".

2. Apply grease to a 1/8 x 27 NPSF tap and thread the hole.
3. Drain fluid by propping converter in a drain pan with the drilled hole at the bottom. Drain approximately 15 minutes.
4. Charge converter hub with air to remove as much contaminated transmission fluid as possible. Set converter on pilot, pour in two quarts of cleaning solvent and agitate. Redrain converter and use air to blow dry.
5. Coat a 1/8 x 27 NPTF pipe plug with teflon pipe sealant or equivalent and install. Use pipe plug part number 9427882 or equivalent.
6. Torque to 8 ft. lbs.
7. Pressure test the converter for leaks at 80 psi using tool J-21369. Put liquid soap or leak-detecting solution on the pipe plug and watch for bubbles.

### Torque Converter Evaluation

The converter should only be replaced if one of the following conditions exist:

1. Either the front oil pump cover or body are badly scored, which results in cast iron grindings entering the converter and thus, the oil circuit. This could be a result of the drive gear wearing into the crescent, or down into the pocket, or the outer gear wearing in the pocket or some other condition such as a cracked flexplate, causing the drive lugs on the drive gear to become badly damaged.
2. Internal converter failure, such as the stator overrun clutch not locking, thrust bearing failure, etc. Such failures are also normally associated with

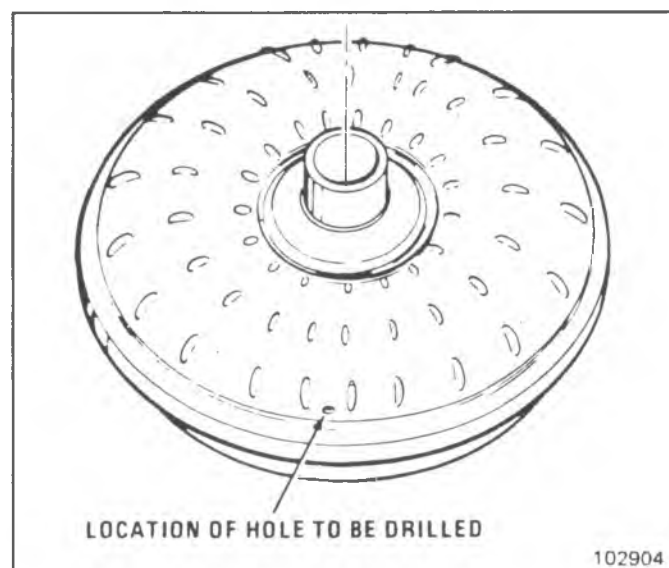

Figure 20--Converter Drilling

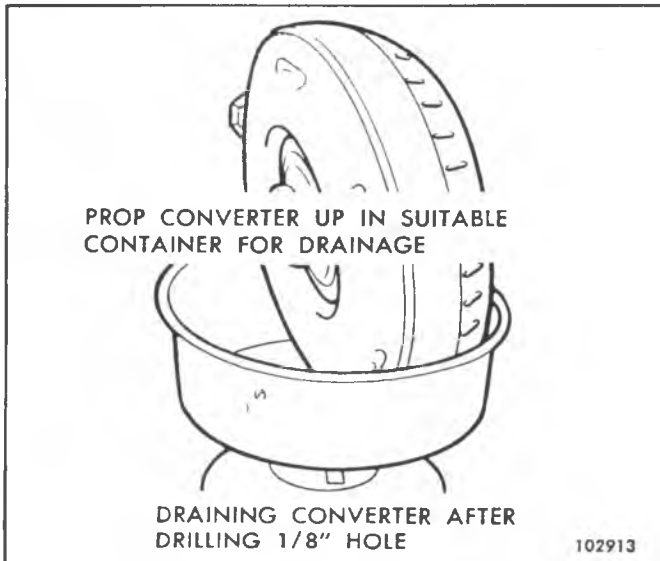

Figure 21--Draining Converter

"aluminized" oil in the converter.

3. End play in the converter exceeds 1.27 mm (.050"). This measurement cannot be estimated, but must be made with tool J-21371.
4. Leaking externally, such as at the hub weld area. A converter that has been in service and which did not leak, very likely never will.
5. A scored, or otherwise damaged hub, which could cause a front seal failure or front pump bushing failure.
6. A broken, damaged, or even possibly a bad fitting converter pilot, which could cause the converter to either not fit into the crankshaft bore properly or not be correctly aligned with the crankshaft.
7. The converter has an unbalance which results in a vibration that cannot be corrected. Most such problems are minimal and most times can be corrected by following Converter Vibration Procedure. A secondary balance procedure is to balance flywheel. If the original balance weights have broken loose and the procedure discussed does not correct the condition, then the converter should be replaced.

The converter should not be replaced for one of the following conditions:

1. The oil has an odor, is discolored, and there is no evidence of metal particles. There is no indication that there is internal damage, nor any front pump damage. Dump out as much oil as possible from the converter and replace only the oil filter in the pan.
2. The oil cooler was defective which allowed engine coolant to enter the transmission. Drill, drain and repair the converter as described in converter flushing procedure. (Including T.C.C. Converters).
3. A small amount of wear (sometimes referred to as fretting wear) appears on the hub where the oil pump drive gear locates. A certain amount of such wear is normal for both the hub and oil pump gear. Neither the converter nor the front pump assembly should be replaced.
4. The threads in one or more of the three converter bolts holes are damaged. Correct such conditions with the use of a Heli-Coil or its equivalent.

## GENERAL SERVICE PROCEDURES

### Engine Coolant In Transmission

If the transmission oil cooler, located in the radiator assembly, has developed a leak allowing engine coolant to enter the transmission, use the following procedure:

1. Remove transmission from vehicle.
2. Disassemble transmission and replace all rubber type seals. (The coolant will attack the seal material causing leakage.)
3. Replace the composition-faced clutch plate assemblies. (The facing material may become separated from the steel center portion).
4. Replace the nylon washers, speedometers gears and governor gear. (The nylon can swell and become damaged.)
5. Flush the converter, including T.C.C. types.
6. Thoroughly clean and rebuild transmission, using new gaskets and oil filter.
7. Flush the cooler lines after the transmission cooler has been properly repaired or replaced.

### Clutch Plate Diagnosis

1. Compositioned Plates.
  - a. Dry plates and inspect for pitting, flaking, wear, glazing, cracking, charring and chips or metal particles imbedded in lining.
  - b. If a compositioned plate shows any of the above conditions, replacement is required.
2. Steel Plates.
  - a. Wipe plates dry and check for discoloration. If the surface is smooth and even color smear is indicated, the plate should be reused. If severe heat spot discoloration or surface scuffing is indicated, the plate must be replaced.
3. Clutch Release Spring.
  - a. Evidence of extreme heat or burning in the area of the clutch may have caused the springs to take a heat set and would require replacement of the

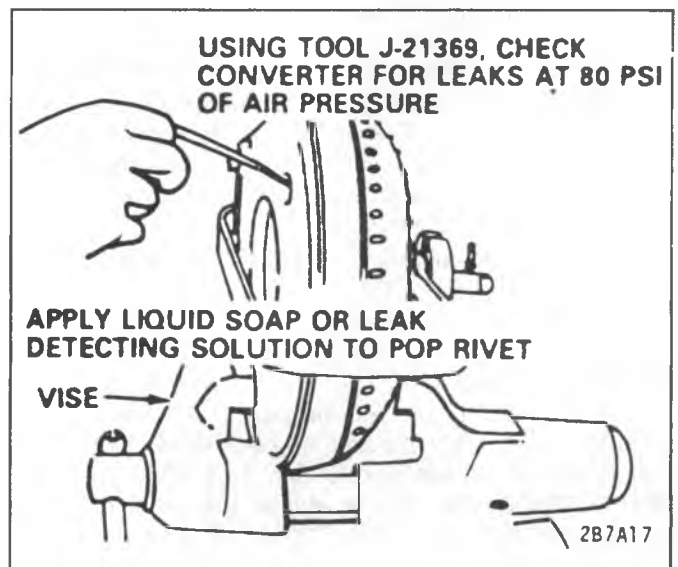

Figure 22--Pressure Testing Converter

springs.

### Causes of Burned Clutch Plates

1. Forward Clutch
  - a. Check ball in clutch housing damaged, stuck or missing.
  - b. Clutch piston cracked, seals damaged or missing.
  - c. Low line pressure.
  - d. Pump cover oil seal rings missing, broken or undersize, ring groove oversize.
  - e. Case valve body face not flat or porosity between channels.
2. Intermediate Clutch
  - a. Intermediate clutch piston seals damaged or missing.
  - b. Low line pressure.
  - c. Case valve body face not flat or porosity between channels.
3. Direct Clutch
  - a. Clutch piston seals damaged or missing.
  - b. Case valve body face not flat or porosity between channels.

Burned clutch plates can be caused by incorrect usage of clutch plates. Also, engine coolant in transmission fluid can cause severe damage, such as large pieces of composition clutch plate material peeling off.

### Case Porosity Repair

External leaks caused by case porosity have successfully been repaired with the transmission in the vehicle by using the following recommended procedures:

1. Road test and bring the transmission to operating temperature, approximately 93°C (200°F).
2. Raise vehicle on a hoist or jack stand, engine running and locate source of oil leak. Check for leak in all operating positions. A mirror may be helpful in finding leaks.
3. Shut engine off and thoroughly clean area to be repaired with a cleaning solvent and air dry.
4. Using instructions of the manufacturer, mix a sufficient amount of epoxy, No. 1052533, or equivalent to make repair. Observe cautions of manufacturer in handling.
5. While the transmission case is still HOT, apply the epoxy to the area to be repaired. A clean, dry soldering acid brush can be used to clean the area and also to apply the epoxy cement. Make certain the area to be repaired is fully covered.
6. Allow cement to cure for three hours before starting engine.
7. Road test and check for leaks.

### Service Methods

When servicing the transmission, it is recommended that upon disassembly of a unit, all parts should be cleaned and inspected as outlined under **CLEANING AND INSPECTION**. The unit should be reassembled before disassembly of other units to avoid confusion and interchanging of parts.

1. Before disassembly of the unit, thoroughly clean the exterior.
2. Disassembly and reassembly of the unit and the subassemblies must be made on a clean bench. As in repairing any hydraulically operated unit, cleanliness is of the utmost importance; therefore, the bench, tools, and parts must be kept clean at all times.
3. Before installing cap screws into aluminum parts, **ALWAYS DIP SCREWS INTO TRANSMISSION OIL** to prevent cap screws from galling the aluminum threads and also to prevent the screws from seizing.
4. Always use a torque wrench when installing cap screws into aluminum parts to prevent the possibility of stripping the threads.
5. If tapped, threads in aluminum parts are stripped or damaged, the part can be made serviceable by the use of Heli-Coils or equivalent.
6. Seal protecting tools must be used when assembling the units to prevent damage to the seals. The slightest flaw in the sealing surface of the seal can cause an oil leak.
7. The aluminum castings and the valve parts are very susceptible to nicks, burrs, etc., and care should be exercised when handling them.
8. The internal snap rings should be expanded and the external snap rings compressed if they are to be reused. This will insure proper seating when installed.
9. Replace all "O" rings, gaskets and oil seals that are removed. Oil seal rings should not be removed unless damaged.
10. During assembly of each unit, all internal parts must be lubricated with oil.

### Parts Cleaning and Inspection

Cleanliness is an important factor in the overhaul of the transmission. Before attempting any disassembly operation, the exterior of the transmission should be thoroughly cleaned to prevent the possibility of dirt entering the transmission internal mechanism. During inspection and reassembly, all parts should be thoroughly cleaned with cleaning fluid and then air dried. Wiping cloths or rags should not be used to dry parts. Do not use solvents on neoprene seals, composition-faced clutch plates or thrust washers. All oil passages should be blown out and checked to make sure that they are not obstructed. Small passages should be checked with tag wire. All parts should be inspected to determine which parts are to be replaced.

The various inspections of parts are as follows:

1. Inspect linkage and pivot points for excessive wear.
2. Bearing and thrust surfaces of all parts should be checked for excessive wear and scoring.
3. Check for broken seal rings, damaged ring lands and damaged threads.
4. Inspect seals and "O" rings.
5. Mating surfaces of castings and end plate should be checked for burrs and irregularities may be removed by lapping the surface with crocus cloth. The crocus cloth should be laid on a flat surface, such as a piece of plate glass.
6. Castings should be checked for cracks and sand holes.

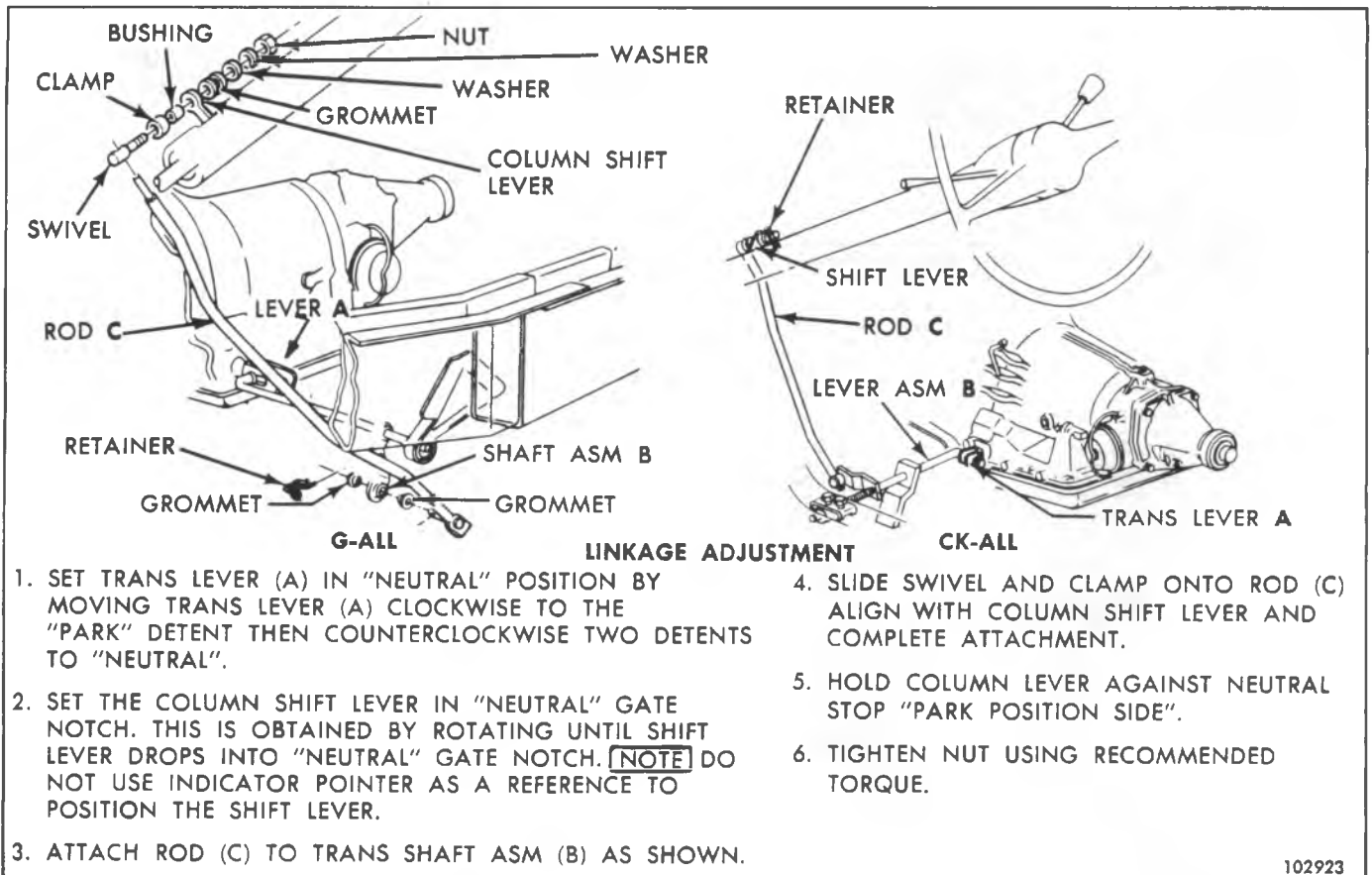

Fig. 7A-23--Column Shift Linkage Adj.

**Oil Cooler Pipes**

If replacement of transmission steel tubing cooler lines is required, use only double wrapped and brazed steel tubing meeting GM specification 123M or equivalent. Under no condition use copper or aluminum tubing to replace steel tubing. Those materials do not have satisfactory fatigue durability to withstand normal vehicle vibrations. Steel tubing should be flared using the double flare method.

**Cooler Line Flushing**

In a major transmission failure, where particles of metal have been carried with the oil throughout the units of the transmission, it will be necessary to flush out the oil cooler and connecting lines. To flush the oil cooler and lines, use the following procedure:

1. Disconnect both cooler lines from the transmission.
2. Place a hose over the end of the cooler inlet line (from the bottom of the cooler) and insert the hose into an empty container.
3. Flush clean oleum solvent or equivalent through the return line (from the top of the cooler) using an oil suction gun until clean solvent comes out of the hose. This will "back flush" the cooler.
4. Remove the hose from the inlet cooler line and place it on the return line.
5. Flush clean oleum solvent or equivalent through the inlet line until clean solvent comes out the return line. Remove remaining solvent from cooler with

compressed air applied to the return line and flush with transmission fluid.

6. Reconnect oil cooler lines and torque nuts to 17 N·m (12 ft. lbs.).

**SERVO ASSEMBLY**

**Removal and Installation 700-R-4**

1. Disconnect battery cable.
2. Raise the vehicle.
3. Using tool J-29714, remove 2-4 servo cover and retaining ring.
4. Remove 4th gear apply piston and "O" ring.
5. Remove 2nd gear servo piston assembly.
6. Remove the inner servo piston assembly, oil seal and spring.
7. Check the apply pin using Tool J-33037.
8. To install, just reverse Steps 1 through 6.
9. Lower the vehicle, check and fill transmission fluid.

**SPEEDOMETER DRIVEN GEAR (350C, 400, 700-R4)**

**Removal and Installation**

1. Disconnect speedometer cable.
2. Remove retainer bolt, retainer, speedometer driven gear and "O" ring seal.
3. To install, reverse removal procedure, using new "O" ring seal (if required) and adjust fluid level.

THE FOLLOWING PARTS CAN BE SERVICED WITH THE TRANSMISSION IN THE VEHICLE. FOR REMOVAL AND INSTALLATION PROCEDURES NOT LISTED IN THIS SECTION REFER TO THE APPROPRIATE UNIT REPAIR SECTION.

|   | 350 C   | 400 | 700-R4 |
|---|---------|-----|--------|
| 1. Governor Cover and Seals                             | X       | X   | X      |
| 2. Governor Assembly                                    | X       | X   | X      |
| 3. Governor Pressure Switch (Diesel only)               |         |     | X      |
| 4. Governor Pipes                                       |         | X   |        |
| 5. Intermediate Servo Cover and Seal                    | X       |     | X      |
| 6. Intermediate Servo Piston Assembly                   |         | X   | X      |
| 7. Rear Servo Assembly                                  |         | X   |        |
| 8. Front Servo Assembly                                 |         | X   |        |
| 9. 3rd Accumulator Check Valve Assembly                 |         |     | X      |
| 10. Oil Pan and Oil Screen (Intake Pipe) Assembly       | X       | X   | X      |
| 11. Control Valve Assembly (Valve Body)                 | X       | X   | X      |
| 12. Auxillary Valve Body Assembly                       | X       |     |        |
| 13. Check Balls and Valve Body Space Plates and Gaskets | X       | X   | X      |
| 14. Pressure Regulator Parts                            | X       | X   | X      |
| 15. Inside Detent/Range Lever                           | X       |     | X      |
| 16. Manual Detent Roller and Spring Assembly            | X       | X   | X      |
| 17. Throttle Lever and Bracket Assembly                 |         |     | X      |
| 18. TV/Detent Cable and 'O' Ring                        | X       |     | X      |
| 19. TV Boost Valve and Bushing                          |         |     |        |
| 20. Parking Pawl Actuator Rod                           | X       | X   | X      |
| 21. Parking Pawl Bracket                                | X       | X   | X      |
| 22. Parking Pawl  | X       | X   | X      |
| 23. Manual Shaft and Seal                               | X       | X   | X      |
| 24. Manual Valve  | X       | X   | X      |
| 25. Manual Valve Link                                   | X       | X   | X      |
| 26. Extension Housing and Gasket                        | X       | X   | X      |
| 27. Rear Seal   | X       | X   | X      |
| 28. 1-2 Accumulator Assembly                            | X       | X   | X      |
| 29. 3-4 Accumulator Assembly                            |         |     | X      |
| 30. Low and Reverse Clutch Cup Plug                     |         |     |        |
| 31. Reverse Boost Valve and Bushing                     |         |     |        |
| 32. Stop Valve  |         |     |        |
| 33. Intermediate Band Anchor Pin                        |         |     | X      |
| 34. 4-3 Pressure Switch                                 |         |     |        |
| 35. 4th Clutch Pressure Switch                          |         |     |        |
| 36. Vacuum Modulator                                    | X       | X   |        |
| 37. Cooler Fittings                                     | X       | X   | X      |
| 38. Oil Filter Pipe and 'O' Ring                        |         | X   | X      |
| 39. Speedometer Driven Gear Assembly                    | X       | X   | X      |
| 40. Speedometer Drive Gear                              | X       |     | X      |
| 41. Down Shift Solenoid                                 |         | X   |        |
| 42. Converter Clutch Valve and Springs                  | X       |     |        |
| 43. Converter Clutch Solenoid                           | X       |     | X      |
| 44. Solenoid Wire Clips                                 | X       |     | X      |
| 45. Electrical Connectors                               | X       | X   | X      |
| 46. Governor Feed Screen                                | X       | X   |        |
| 47. Pump Pressure Screen                                | X       | X   |        |
| 48. Modulator Valve                                     | X       | X   |        |
| 49. Intermediate Band Adjustment                        | 2B7A11A |     |        |

Fig. 7A-24--On-Vehicle Service Items

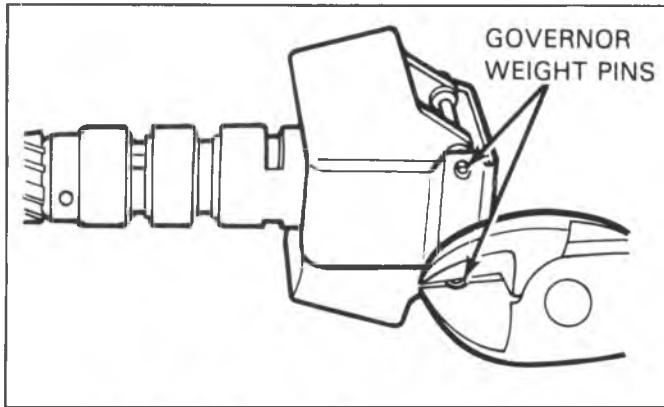

Fig. 7A-25--Removing Governor Weight Pins

### REAR OIL SEAL (350C, 400, 700-R4)

#### Removal and Installation

1. Remove propeller shaft as outlined in Section 4A.
2. Pry out lip oil seal with suitable tool.
3. Coat outer casing of new lip oil seal with a nonhardening sealer and drive it into place with Installer J-21426 (700-R4) J-21359 or J-24057 (400).
4. Install propeller shaft as outlined in Section 4A and adjust fluid level.

### GOVERNOR

#### Removal and Installation

#### 350C

1. Remove governor cover and "O" ring seal from case. Aid removal of cover with screwdriver. Use extreme care not to damage cover. If cover is damaged, it must be replaced.
2. Withdraw governor assembly from case. Check governor bore and governor sleeve for scoring. The governor should be replaced only if the O.D. surface of the sleeve is scored, the carrier is loose on the sleeve, or the valve is sticking in the sleeve, after a thorough cleaning has been attempted.
3. When installing governor cover, uniformly apply Loctite Cup Plug Sealer #2 or equivalent to governor cover.

#### 400

1. Raise vehicle.
2. Remove governor cover attaching screws, cover and gasket. Discard gasket.
3. Remove governor assembly from case.
4. Refer to the Overhaul Section for inspection procedures.
5. Install governor.
6. Using a new gasket, install cover and retaining bolts. Torque bolts to specifications.
7. Lower vehicle and adjust fluid level.

#### 700-4R

1. Raise vehicle.
2. Remove governor cover from case using a screwdriver. Use extreme care not to damage cover. If cover is damaged, it must be replaced.
3. Remove governor.
4. Refer to the Overhaul Section for inspection procedure.
5. Install governor.
6. Apply anaerobic sealant, such as Loctite Cup Plug Sealant II, or equivalent, to cover, then install governor cover using a brass drift around the outside flange of the cover. Do not distort cover on installation.
7. Lower vehicle and check transmission fluid level.

#### 350C, 700-R4 and 400 Governor Repair

All parts of the governor assembly, with the exception of the driven gear, are a select fit and each assembly is calibrated. The governor, including the driven gear, is serviced as a complete assembly. However, the driven gear can also be serviced separately.

It is necessary to disassemble the governor assembly in order to replace the driven gear. Disassembly may also be necessary due to foreign material causing improper operation. In such cases, proceed as follows:

1. Cut off one end of each governor weight pin and remove pins, governor thrust cap, governor weights, and springs. Governor weights are interchangeable from side to side and need not be identified. (Fig. 7A-25).
2. Remove governor valve from governor sleeve. Be careful not to damage valve.
3. Perform the following inspections and replace governor driven gear, if necessary.

#### Inspection

1. Wash all parts in cleaning solvent, air dry and blow out all passages.
2. Inspect governor sleeve for nicks, burrs, scoring or galling.
3. Check governor sleeve for free operation in bore of transmission case.
4. Inspect governor valve for nicks, burrs, scoring or galling.
5. Check governor valve for free operation in bore of governor sleeve.
6. Inspect governor driven gear for nicks, burrs, or damage.
7. Check governor driven gear for looseness on governor sleeve.
8. Inspect governor weight springs for distortion or damage.
9. Check governor weights for free operation in their retainers.
10. Check valve opening at entry 5.1mm (.020") minimum with a feeler gage, holding governor as shown with governor weights extended completely outward (Fig. 7A-26).
11. Check valve opening at exhaust 5.1 mm (.020") minimum with a feeler gage, holding governor as shown



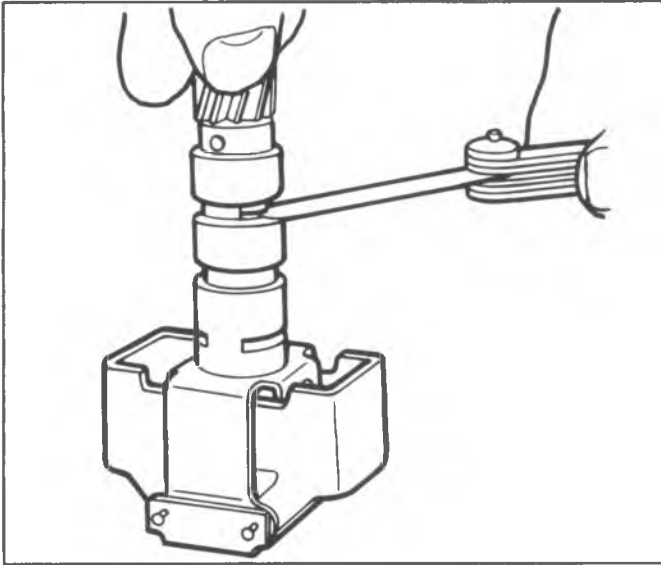

Fig. 7A-26--Check Valve Opening (Entry)

with governor weights completely inward (Fig. 7A-27). Sleeve must be tight in carrier.

#### Governor Driven Gear Replacement

To facilitate governor repair in the field, governor driven gear and replacement pins are available for service use. The service package contains a nylon driven gear, two governor weight retaining pins and one governor gear retainer split pin. Replacement of gear must be performed with care in the following manner:

1. Drive out governor gear retaining split pin using small punch or 1/8" drill rod.
2. Support governor on 7/64" plates installed in exhaust slots of governor sleeve, place in press, and with a long punch, press gear out of sleeve.
3. Carefully clean governor sleeve of chips that remain from original gear installation.
4. Support governor on 7/64" plates, installed in exhaust slots of sleeve, position new gear in sleeve and, with a suitable socket, press gear into sleeve until nearly seated. Carefully remove any chips that

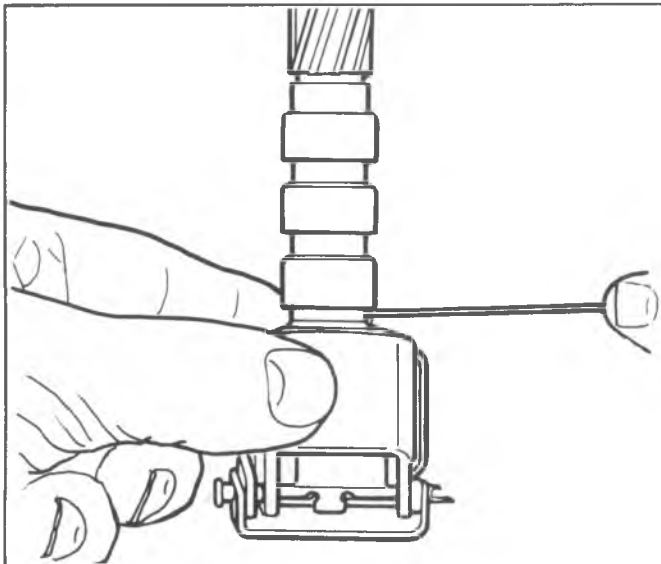

Fig. 7A-27--Check Valve Opening (Exhaust)

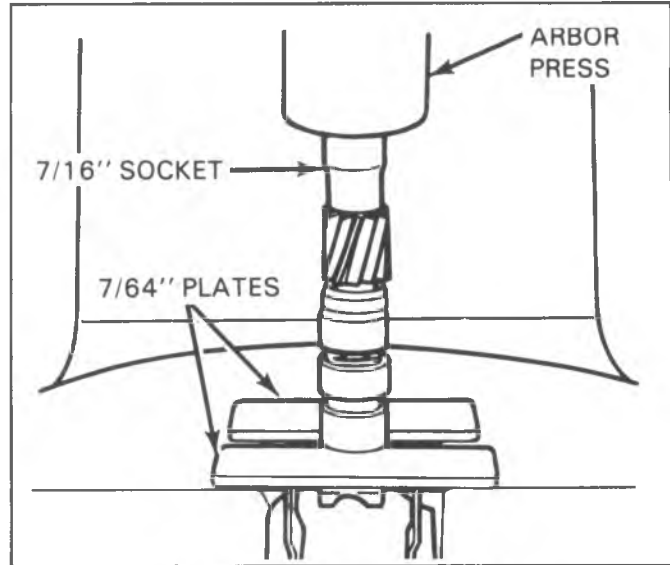

Fig. 7A-28--Installing Driven Gear

may have shaved off gear hub and press gear in until it bottoms on shoulder (Fig. 7A-28).

5. A new pin hole must be drilled through sleeve and gear. Locate hole position 90° from existing hole, center punch, and then while supporting governor in press, drill new hole through sleeve and gear using a standard 1/8" drill (Fig. 7A-29).
6. Install retaining pin, making sure each end is slightly below top of hole.
7. Stake both ends of pin hole, two places.
8. Wash governor assembly thoroughly to remove any chips that may have collected.

#### Assembly

1. Install governor valve in bore of governor sleeve.
2. Install governor weights and springs, and thrust cap on governor sleeve.
3. Align pin holes in thrust cap, governor weight assemblies and governor sleeve, and install new pins. Crimp both ends of pins to prevent them from falling out.

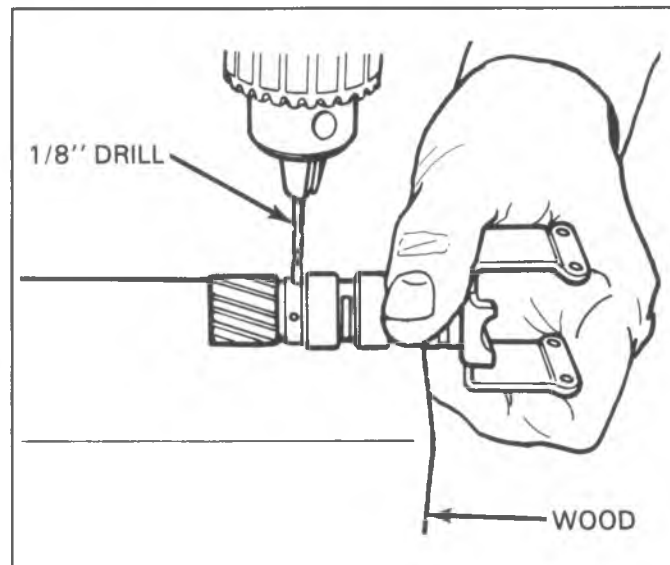

Fig. 7A-29--Drilling Hole in Driven Gear

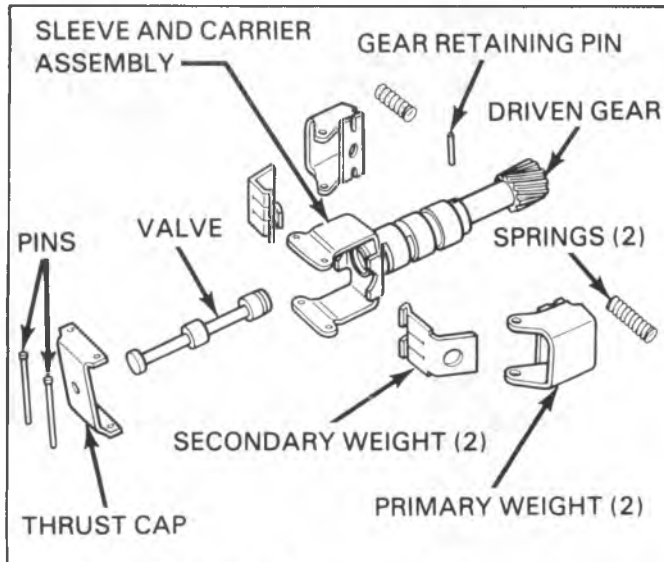

Fig. 7A-30--Governor Assembly

4. Check governor weight assemblies for free operation on pins, and governor valve for free operation in governor sleeve.

### PRESSURE REGULATOR VALVE (400)

#### Removal and Installation

1. Raise vehicle.
2. Referring to draining procedures, drain transmission fluid from oil pan.
3. Remove oil pan, gasket and screen.
4. Compress regulator boost valve bushing against pressure regulator spring and remove snap ring, using J-5403.
5. Remove regulator boost valve bushing and valve.
6. Remove pressure regulator spring.
7. Remove spring retainer, washer spacer(s), if present, and regulator valve.
8. Installation of pressure regulator valve is the reverse of the removal. Install new gasket on oil pan and adjust fluid level.
9. Lower vehicle.

### CONTROL VALVE ASSEMBLY

#### Control Valve Assembly

#### 350C

1. Refer to draining procedures, drain transmission fluid from oil pan.
2. Remove oil pan, gasket and filter. Disconnect electrical connectors at valve body.
3. Remove detent spring and roller assembly from valve body and remove valve body-to-case bolts.
4. Remove valve body assembly while disconnecting manual control valve link from range selector inner lever and removing detent control valve link from the detent actuating lever.

5. Remove manual valve and link assembly from valve body assembly.
6. Refer to the Overhaul Section for inspection procedures.
7. Installation of control valve assembly is the reverse of removal. Torque valve body bolts to 17 N·m (12 ft. lbs.).

Refer to Refilling of Transmission portion of this section for correct fluid level.

#### 400

1. Refer to draining procedures, drain transmission fluid from oil pan.
2. Remove oil pan, gasket and filter.
3. Disconnect lead wire from pressure switch assembly.
4. Remove control valve body attaching bolts and detent roller spring assembly.
5. Remove control valve body assembly and governor pipes.
6. Remove the governor screen from end of governor feed pipe or from the feed pipe hole in the case. Clean governor screen in clean solvent and air dry.
7. Refer to the Overhaul Section for inspection procedures.
8. Installation of control valve assembly is the reverse of removal. Torque valve body bolts to 10 N·m (8 ft. lbs.).

Refer to Refilling of Transmission portion of this section for correct fluid level.

#### 700-R4

1. Refer to draining procedures, drain transmission fluid from oil pan.
2. Remove oil pan, gasket and filter.
3. Disconnect electrical connectors at valve body.
4. Remove detent spring and roller assembly from valve body and remove valve body-to-case bolts.
5. Remove valve body assembly while disconnecting manual control valve link from range selector inner lever and removing the throttle lever bracket from T.V. link.
6. Refer to the Overhaul Section for inspection procedures.
7. Installation of control valve assembly is the reverse of removal. Torque valve body bolts to 11 N·m (8 ft. lbs.).

Refer to Refilling of Transmission portion of this section for correct fluid level.

### VACUUM MODULATOR (350C, 400)

#### Removal and Installation

1. Disconnect vacuum hose from vacuum modulator stem and remove vacuum modulator attaching screw and retainer.
2. Remove modulator assembly and its "O" ring seal from case.
3. Remove modulator valve from case.
4. Installation of the modulator and modulator valve is the reverse of REMOVAL. Install a new "O" ring seal and adjust the fluid level.

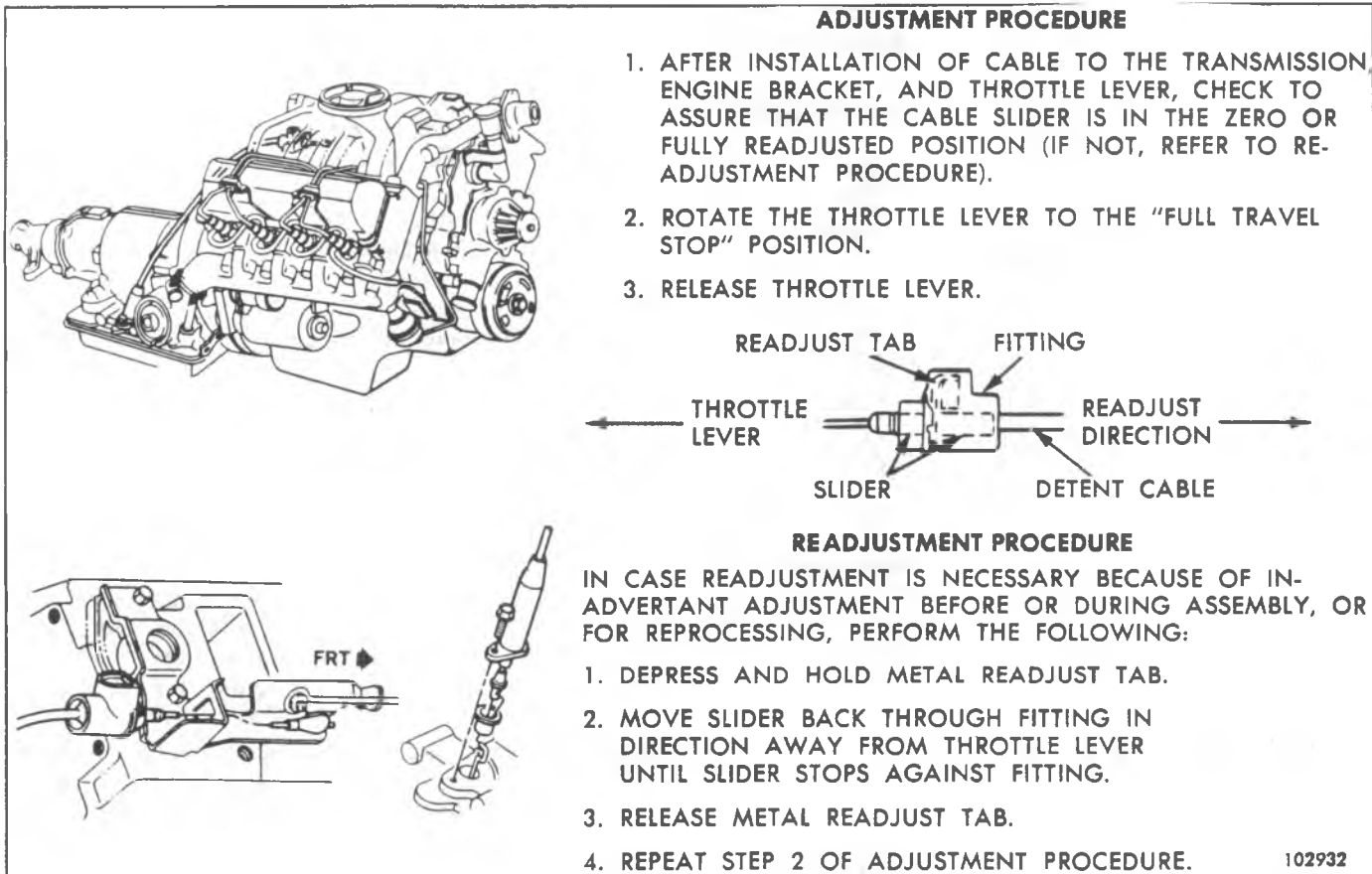
**ADJUSTMENT PROCEDURE**

1. AFTER INSTALLATION OF CABLE TO THE TRANSMISSION, ENGINE BRACKET, AND THROTTLE LEVER, CHECK TO ASSURE THAT THE CABLE SLIDER IS IN THE ZERO OR FULLY READJUSTED POSITION (IF NOT, REFER TO RE-ADJUSTMENT PROCEDURE).
2. ROTATE THE THROTTLE LEVER TO THE "FULL TRAVEL STOP" POSITION.
3. RELEASE THROTTLE LEVER.

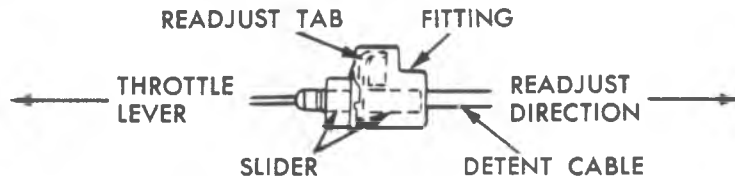
**READJUSTMENT PROCEDURE**

IN CASE READJUSTMENT IS NECESSARY BECAUSE OF IN-ADVERTANT ADJUSTMENT BEFORE OR DURING ASSEMBLY, OR FOR REPROCESSING, PERFORM THE FOLLOWING:

1. DEPRESS AND HOLD METAL READJUST TAB.
2. MOVE SLIDER BACK THROUGH FITTING IN DIRECTION AWAY FROM THROTTLE LEVER UNTIL SLIDER STOPS AGAINST FITTING.
3. RELEASE METAL READJUST TAB.
4. REPEAT STEP 2 OF ADJUSTMENT PROCEDURE.

102932

Fig. 7A-31--T.V./Detent Cable Adj. Diesel Engine

**T.V./DETENT CABLE****Removal and Installation**

1. Remove air cleaner, if necessary.
2. Push in on re-adjust tab and move slider back through fitting in direction away from throttle lever.
3. Disconnect cable terminal from throttle lever, see Figs. 7A-31, 32 and 33.
4. Compress locking tabs and disconnect cable assembly from bracket.
5. Remove routing clips or straps (if used), remove screw and washer securing cable to transmission and disconnect cable from link.
6. Install new seal into transmission case hole.
7. Connect transmission end of cable and secure to transmission case with bolt and washer tightened to 10 N·m (8 lb. ft.).
8. Route cable as removed and connect clips or straps.
9. Pass cable through bracket and engage locking tabs of cable on bracket.
10. Connect cable terminal to throttle lever.
11. Adjust cable - see "Adjustment Procedure".
12. Install air cleaner, if removed.

**TRANSMISSION**

Generally, pressure testing should be performed before transmission removal.

**Removal (Except K Model)**

1. Open hood and place protectors on both fenders.
2. Remove air cleaner assembly.
3. Disconnect T.V./detent cable at its upper end - see "T.V./Detent Cables".
4. Remove transmission oil dipstick (and bolt holding dipstick tube if accessible.)
5. Raise vehicle.
6. Remove propeller shaft as outlined in Section 4A.
7. Disconnect speedometer cable at the transmission.
8. Disconnect shift linkage at transmission.
9. Disconnect all electrical leads at the transmission and any clips that retain the leads to the transmission case.
10. Remove transmission support braces and flywheel cover. Mark flywheel and torque converter to maintain original balance.
11. Remove torque converter to flywheel bolts and/or nuts.
12. Disconnect the catalytic converter support bracket if equipped.
13. Remove transmission mount attaching bolts.
14. Position a transmission jack under the transmission oil pan and raise the transmission slightly.
15. Remove transmission support to frame bolts (and insulators if used).
16. Slide the transmission support rearward and remove from vehicle.

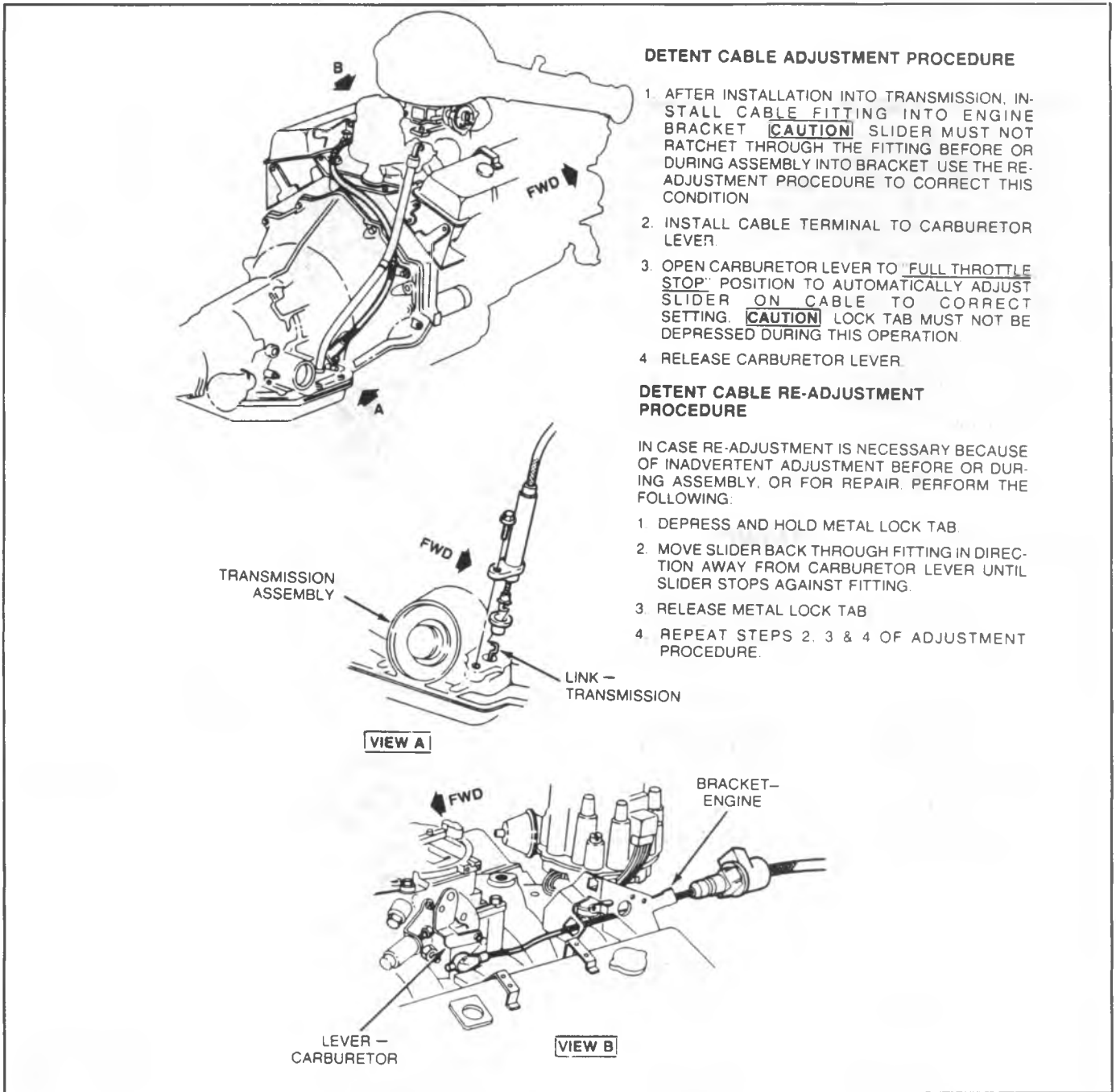

**DETENT CABLE ADJUSTMENT PROCEDURE**

1. AFTER INSTALLATION INTO TRANSMISSION, INSTALL CABLE FITTING INTO ENGINE BRACKET **CAUTION** SLIDER MUST NOT RATCHET THROUGH THE FITTING BEFORE OR DURING ASSEMBLY INTO BRACKET USE THE RE-ADJUSTMENT PROCEDURE TO CORRECT THIS CONDITION
2. INSTALL CABLE TERMINAL TO CARBURETOR LEVER.
3. OPEN CARBURETOR LEVER TO "FULL THROTTLE STOP" POSITION TO AUTOMATICALLY ADJUST SLIDER ON CABLE TO CORRECT SETTING. **CAUTION** LOCK TAB MUST NOT BE DEPRESSED DURING THIS OPERATION
4. RELEASE CARBURETOR LEVER.

**DETENT CABLE RE-ADJUSTMENT PROCEDURE**

IN CASE RE-ADJUSTMENT IS NECESSARY BECAUSE OF INADVERTENT ADJUSTMENT BEFORE OR DURING ASSEMBLY, OR FOR REPAIR, PERFORM THE FOLLOWING:

1. DEPRESS AND HOLD METAL LOCK TAB.
2. MOVE SLIDER BACK THROUGH FITTING IN DIRECTION AWAY FROM CARBURETOR LEVER UNTIL SLIDER STOPS AGAINST FITTING.
3. RELEASE METAL LOCK TAB
4. REPEAT STEPS 2, 3 & 4 OF ADJUSTMENT PROCEDURE.

Fig. 7A-32--T.V./Detent Cable Adj. Gasoline Engine

17. Lower the transmission to gain access to the oil cooler lines and T.V./detent cable attachments.
18. Disconnect the oil cooler lines and T.V./detent cable. Cap all openings.
19. Support engine with a suitable tool and remove the transmission to engine bolts.
20. Disconnect the transmission assembly, being careful not to damage any cables, lines or linkage.
21. Install torque converter holding tool J-21366 and remove the transmission assembly from the vehicle.

**Removal (K Model)**

1. Open hood and place protectors on both fenders.
2. Remove air cleaner.

3. Disconnect T.V./detent cable at its upper end.
4. Remove transfer case shift lever knob and boot.
5. Raise vehicle
6. Remove propeller shafts as outlined in Section 4A.
7. Disconnect speedometer cable at transmission.
8. Disconnect shift linkage at transmission.
9. Disconnect all electrical leads at the transmission, transfer case and any clips that retain the leads.
10. Disconnect transfer case shift linkage.
11. Remove transmission support strut rods and flywheel cover. Mark flywheel and torque converter to maintain original balance.
12. Remove torque converter to flywheel bolts and/or nuts.

**DETENT CABLE ADJUSTMENT PROCEDURE**

1. AFTER INSTALLATION INTO TRANSMISSION, INSTALL CABLE FITTING INTO ENGINE BRACKET. **CAUTION** SLIDER MUST NOT RATCHET THROUGH THE FITTING BEFORE OR DURING ASSEMBLY INTO BRACKET. USE THE READJUSTMENT PROCEDURE TO CORRECT THIS CONDITION.
2. INSTALL CABLE TERMINAL TO CARBURETOR LEVER.
3. OPEN CARBURETOR LEVER TO "FULL THROTTLE STOP" POSITION TO AUTOMATICALLY ADJUST SLIDER ON CABLE TO CORRECT SETTING. **CAUTION** LOCK TAB MUST NOT BE DEPRESSED DURING THIS OPERATION.
4. RELEASE CARBURETOR LEVER.

**DETENT CABLE RE-ADJUSTMENT PROCEDURE**

IN CASE RE-ADJUSTMENT IS NECESSARY BECAUSE OF INADVERTENT ADJUSTMENT BEFORE OR DURING ASSEMBLY, OR FOR REPAIR, PERFORM THE FOLLOWING:

1. DEPRESS AND HOLD METAL LOCK TAB.
2. MOVE SLIDER BACK THROUGH FITTING IN DIRECTION AWAY FROM CARBURETOR LEVER UNTIL SLIDER STOPS AGAINST FITTING.
3. RELEASE METAL LOCK TAB.
4. REPEAT STEPS 2, 3 & 4 OF ADJUSTMENT PROCEDURE.

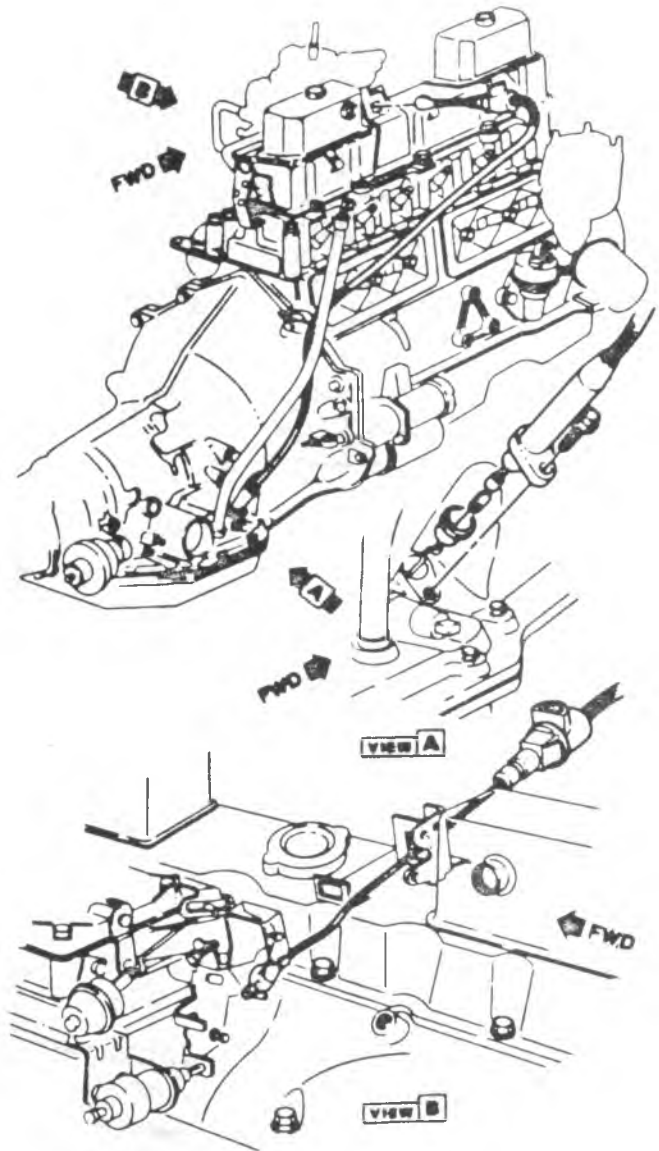

Fig. 7A-33--T.V./Detent Cable Adj. Gasoline Engine

13. Disconnect transmission oil cooler lines at the transmission.
14. Support transmission and transfer case with a jack.
15. Remove transfer case to frame bracket bolts. Remove mount bolts and crossmember.
16. Disconnect transmission to engine bolts, remove transmission and transfer case, being careful not to damage any cables, lines or linkage.

To install, reverse the removal procedure and include the following:

Before installing the flex plate to converter bolts, make certain that the weld nuts on the converter are flush with the

flex plate and the converter rotates freely by hand in this position. Hand start the three bolts and tighten finger tight, then torque to specifications. This will insure proper converter alignment. Install new oil seal on oil filler tube before installing tube.

Torque all fasteners to specifications - See "Specifications". Adjust shift linkage - see "Shift Linkage Adjustments\*".

Adjust T.V./Detent Cable - See "T.V./Detent Cable Adjustment". Refill transmission with fluid - See "Checking and Adding Fluid".

## TRANSMISSION CONVERTER CLUTCH (TCC) ELECTRICAL DIAGNOSIS

MECHANICAL CHECKS, SUCH AS LINKAGE, OIL LEVEL, ETC.,  
SHOULD BE PERFORMED PRIOR TO USING THIS CHART.

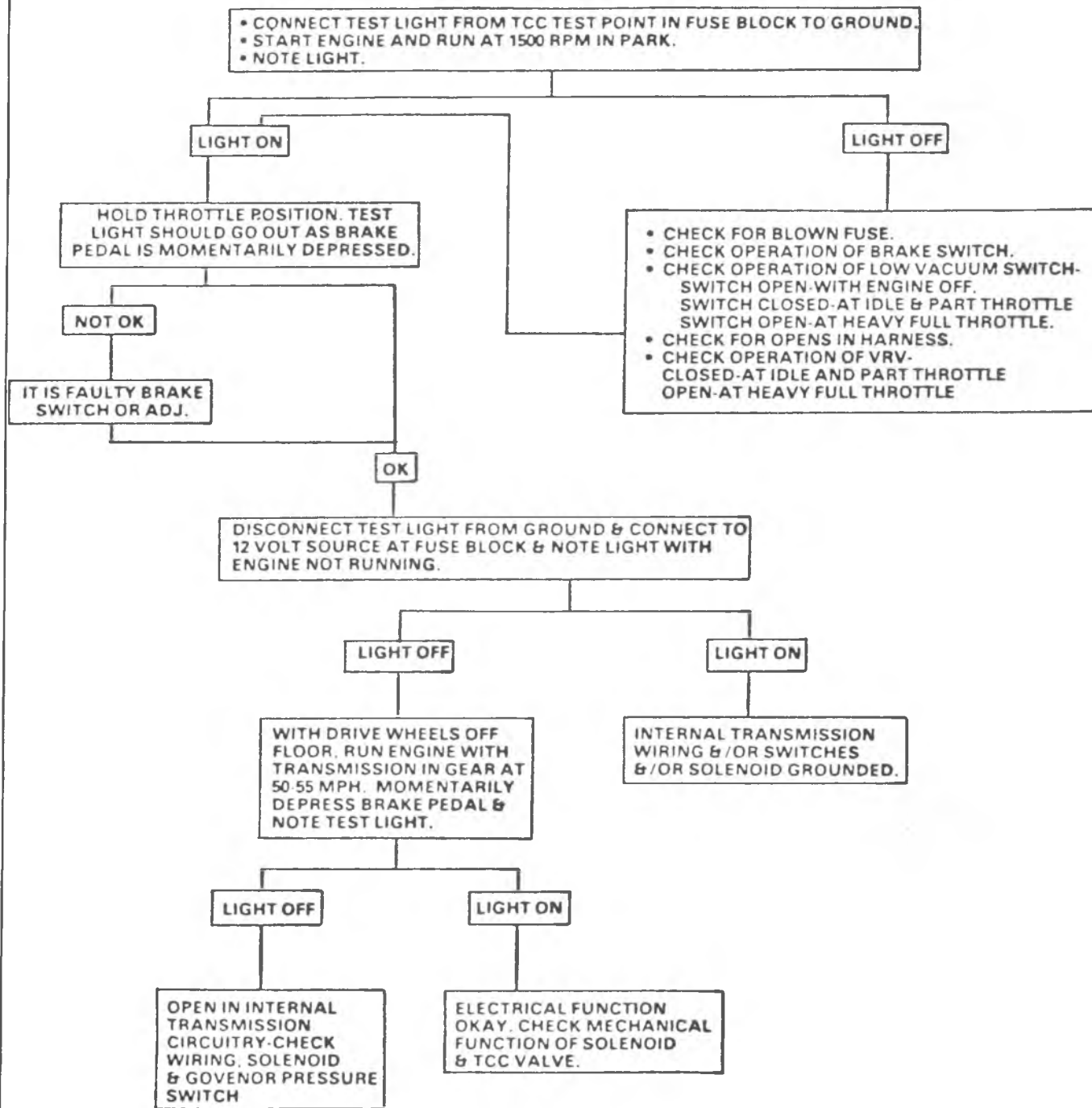

Fig. 7A-34--T.C.C. Diagnosis

|  |         |                |
|--|---------|----------------|
| Transmission to Engine Attachment            | 50 N·m  | ( 35 ft. lbs.) |
| Transmission Support Brace Attachments       | 90 N·m  | ( 65 ft. lbs.) |
| Control Rod Linkage Adjustment Bolt          | 30 N·m  | ( 20 ft. lbs.) |
| TV/Detent Cable to Case                      | 10 N·m  | ( 7 ft. lbs.)  |
| Converter Housing Cover (Except K-Series)    | 10 N·m  | ( 7 ft. lbs.)  |
| Converter Housing Cover (K-Series)           | 35 N·m  | ( 25 ft. lbs.) |
| Oil Cooler Lines to Transmission             | 15 N·m  | ( 10 ft. lbs.) |
| Oil Cooler Lines to Radiator                 | 30 N·m  | ( 20 ft. lbs.) |
| Transfer Case Adapter to Transmission        | 35 N·m  | ( 25 ft. lbs.) |
| Transfer Case Adapter to Transfer Case       | 35 N·m  | ( 25 ft. lbs.) |
| Transfer Case Support Strut to Transfer Case | 175 N·m | (130 ft. lbs.) |
| Transfer Case Support Strut to Engine        | 50 N·m  | ( 35 ft. lbs.) |

102927

Fig. 7A-SP Specifications

# SECTION 350C

## AUTOMATIC 350C TRANSMISSION

### CONTENTS

|  |         |                                    |         |
|--|---------|------------------------------------|---------|
| General Description.....                         | 350C-1  | Sun Gear.....                      | 350C-26 |
| Diagnosis.....                                   | 350C-1  | Low and Reverse Roller Clutch..... | 350C-28 |
| Unit Repair.....                                 | 350C-14 | Valve Body.....                    | 350C-28 |
| External Parts - Removal and Inspection.....     | 350C-14 | Internal Parts - Installation..... | 350C-31 |
| Internal Parts - Removal and Inspection.....     | 350C-17 | External Parts - Installation..... | 350C-35 |
| Internal Parts - Disassembly and Inspection..... | 350C-21 | <b>Bushing Repair</b> .....        | 350C-39 |
| Reassembly.....                                  | 350C-21 | <b>Torque Specifications</b> ..... | 350C-45 |
| Oil Pump.....                                    | 350C-21 | <b>Clutch Plate Chart</b> .....    | 350C-45 |
| Direct Clutch.....                               | 350C-23 | <b>Special Tools</b> .....         | 350C-46 |
| Forward Clutch.....                              | 350C-25 |                                    |         |

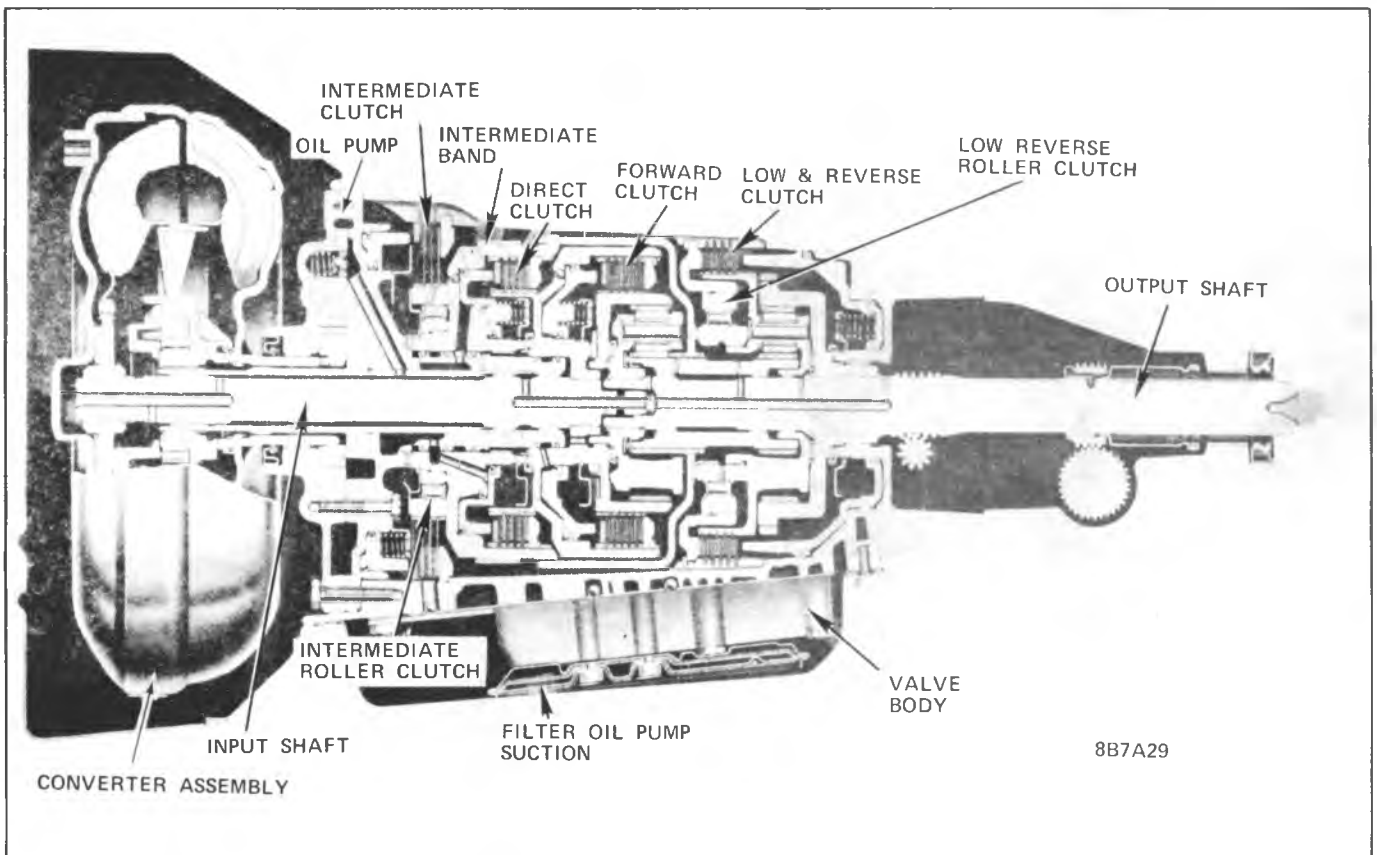

Figure 350C-1 Typical 350 Automatic Transmission

### GENERAL DESCRIPTION

The 350C automatic transmission, is a fully automatic unit consisting primarily of 4-element hydraulic torque converter and two planetary gear sets. Four multiple-disc clutches, two roller clutches, and an intermediate overrun band provide the friction elements required to obtain the desired function of the two planetary gear sets.

A hydraulic system pressurized by a gear type pump provides the working pressure required to operate the friction elements and automatic controls.

External control connections to the transmission are:

1. Manual Linkage - To select the desired operating range.
2. Engine Vacuum - To operate the vacuum modulator.
3. Detent Cable - To operate the detent valve.

### TROUBLE DIAGNOSIS

The key to correcting any complaint is to make use of all the available symptoms and logically letting them direct you to the cause. Symptoms or conditions that will help are determined by subjective road test, oil pressure checks or noise evaluation.

When dealing with automatic transmission complaints, it is best to gather as many symptoms as possible before making the decision to remove the transmission from the vehicle. Remember, **THE VEHICLE IS THE BEST TEST STAND AND DIAGNOSTIC TOOL AVAILABLE TO YOU**, if the transmission is operable. Once the transmission is on the bench, it cannot tell you "what hurts" and quite frequently the correction of the cause of the complaint does not require removal of the transmission from the vehicle.



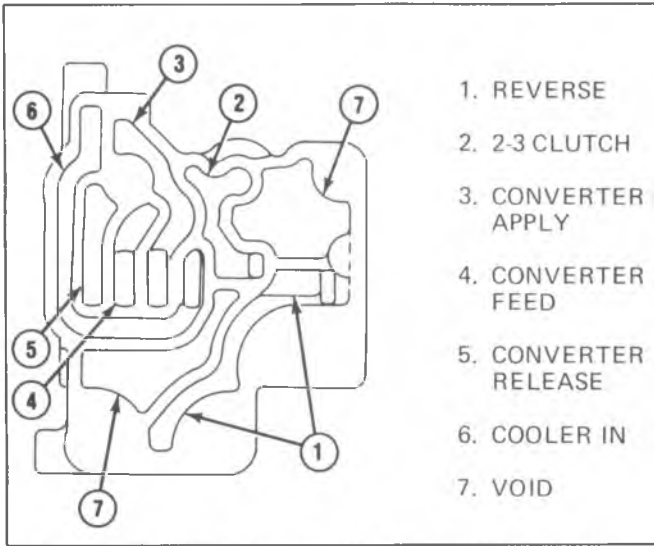

Figure 350C-2 Auxiliary Valve Body Oil Channels

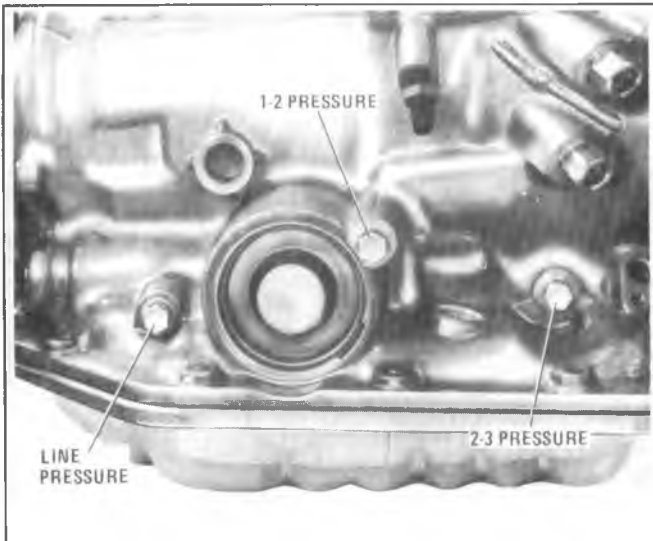
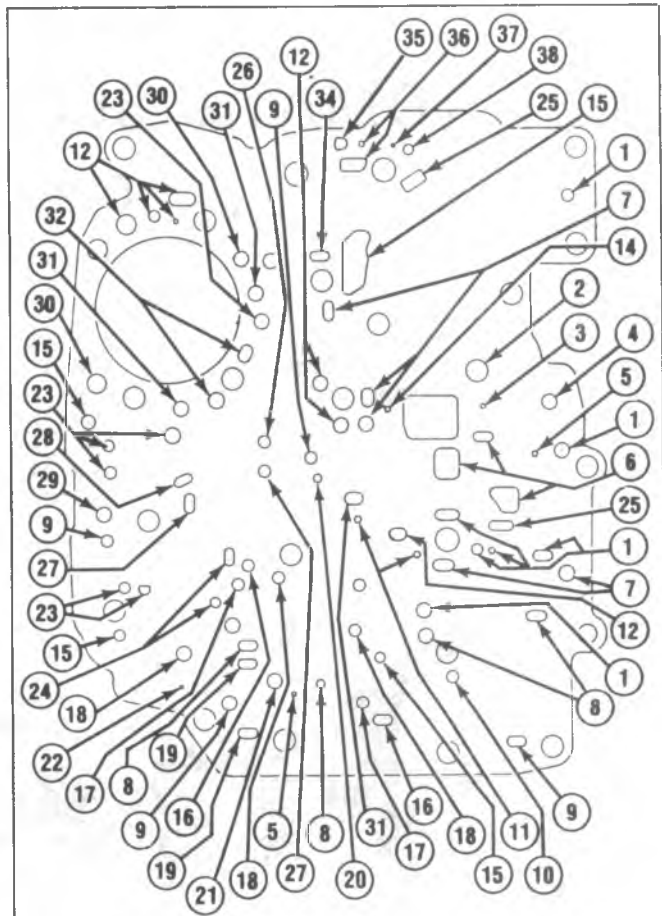

Figure 350C-3 Line Pressure Plug Location



- |                                 |                                   |
|---------------------------------|-----------------------------------|
| 1. REVERSE                      | 18. DETENT                        |
| 2. BOLT HOLE                    | 19. MANUAL LOW CONTROL            |
| 3. PUMP PRESSURE ORIFICE        | 20. EXHAUST 1-2 CLUTCH            |
| 4. EXHAUST                      | 21. LOW REVERSE CLUTCH            |
| 5. REVERSE ORIFICE              | 22. GOVERNOR ORIFICE              |
| 6. PUMP PRESSURE                | 23. LINE                          |
| 7. DRIVE                        | 24. MODULATOR                     |
| 8. LOW                          | 25. CONVERTER FEED                |
| 9. GOVERNOR                     | 26. MODULATOR OR DETENT REGULATOR |
| 10. MODULATOR                   | 27. DETENT REGULATOR              |
| 11. DRIVE ORIFICE               | 28. EXHAUST INT. CLUTCH           |
| 12. DIRECT CLUTCH 2-3           | 29. INTERMEDIATE SERVO (R.N.D.)   |
| 13. SUCTION                     | 30. INTERMEDIATE CLUTCH 1-2       |
| 14. CONVERTER FEED ORIFICE      | 31. INT. SERVO REL. (RND)         |
| 15. DRAIN                       |                                   |
| 16. MODULATOR THRU DETENT VALVE |                                   |
| 17. DETENT MODULATOR (3-2)      |                                   |

5B7C51A

Figure 350C-4 Valve Body Spacer Plate

1983 THM 350C

PRELIMINARY CHECKING PROCEDURE

CHECK TRANSMISSION OIL LEVEL

CHECK OUTSIDE MANUAL LINKAGE AND CORRECT

CHECK ENGINE TUNE

TOTAL RUNNING TIME FOR THIS COMBINATION NOT TO EXCEED 2 MINUTES.

INSTALL OIL PRESSURE GAGE

CONNECT VACUUM GAGE TO MODULATOR LINE & TACHOMETER TO ENGINE

CHECK OIL PRESSURES IN FOLLOWING MANNER

| RANGE  | MODELS             | -- PSI --                    |                                  |
|--|--------------------|------------------------------|----------------------------------|
|  |                    | Modulator*<br>Line Connected | Modulator**<br>Line Disconnected |
| DRIVE – BRAKES APPLIED   | WD, WH, WJ, WE, KE | 57-63                        | 125-135                          |
|  | KA, KC, KN, V4     | 57-63                        | 145-165                          |
|  | LB, LJ             | 64-70                        | 120-130                          |
|  | LD                 | 64-70                        | 140-152                          |
| L <sub>2</sub> or L <sub>1</sub> – BRAKES APPLIED                      | WD, WH, WJ, WE, KE | 85-93                        | 125-135                          |
|  | KA, KC, V4, KN     | 83-91                        | 145-165                          |
|  | LB, LJ             | 79-87                        | 120-130                          |
|  | LD                 | 95-105                       | 140-152                          |
| REVERSE – BRAKES APPLIED   | WD, WH, WJ, WE, KE | 88-96                        | 225-245                          |
|  | KA, KC, V4, KN     | 85-96                        | 230-280                          |
|  | LB, LJ             | 95-106                       | 205-220                          |
|  | LD                 | 98-108                       | 230-245                          |
| NEUTRAL – BRAKES APPLIED   | WP, WH, WJ, WE, KE | 55-64                        | 119-139                          |
|  | KA, KC, V4, KN     | 57-63                        | 145-165                          |
|  | LB, LJ             | 64-70                        | 120-130                          |
|  | LD                 | 64-70                        | 140-152                          |
| DRIVE IDLE –<br>SET ENGINE IDLE<br>TO SPECIFICATIONS<br>BRAKES APPLIED | WD, WH, WJ, WE, KE | 57-63                        |                                  |
|  | KA, KC, V4, KN     | 57-63                        |                                  |
|  | LB, LJ             | 64-70                        |                                  |
|  | LD                 | 64-70                        |                                  |
| DRIVE – 30 MPH<br>CLOSED THROTTLE<br>OR ON HOIST*                      | WD, WH, WJ, WE, KE | 57-63                        |                                  |
|  | KA, KC, V4, KN     | 57-63                        |                                  |
|  | LB, LJ             | 64-70                        |                                  |
|  | LD                 | 64-70                        |                                  |

\*MODULATOR LINE CONNECTED: Run engine to 1,000 RPM, close throttle and check PSI

\*\*MODULATOR LINE DISCONNECTED: Check PSI at 1,000 RPM, throttle open

Figure 350C-5 Oil Pressure Chart

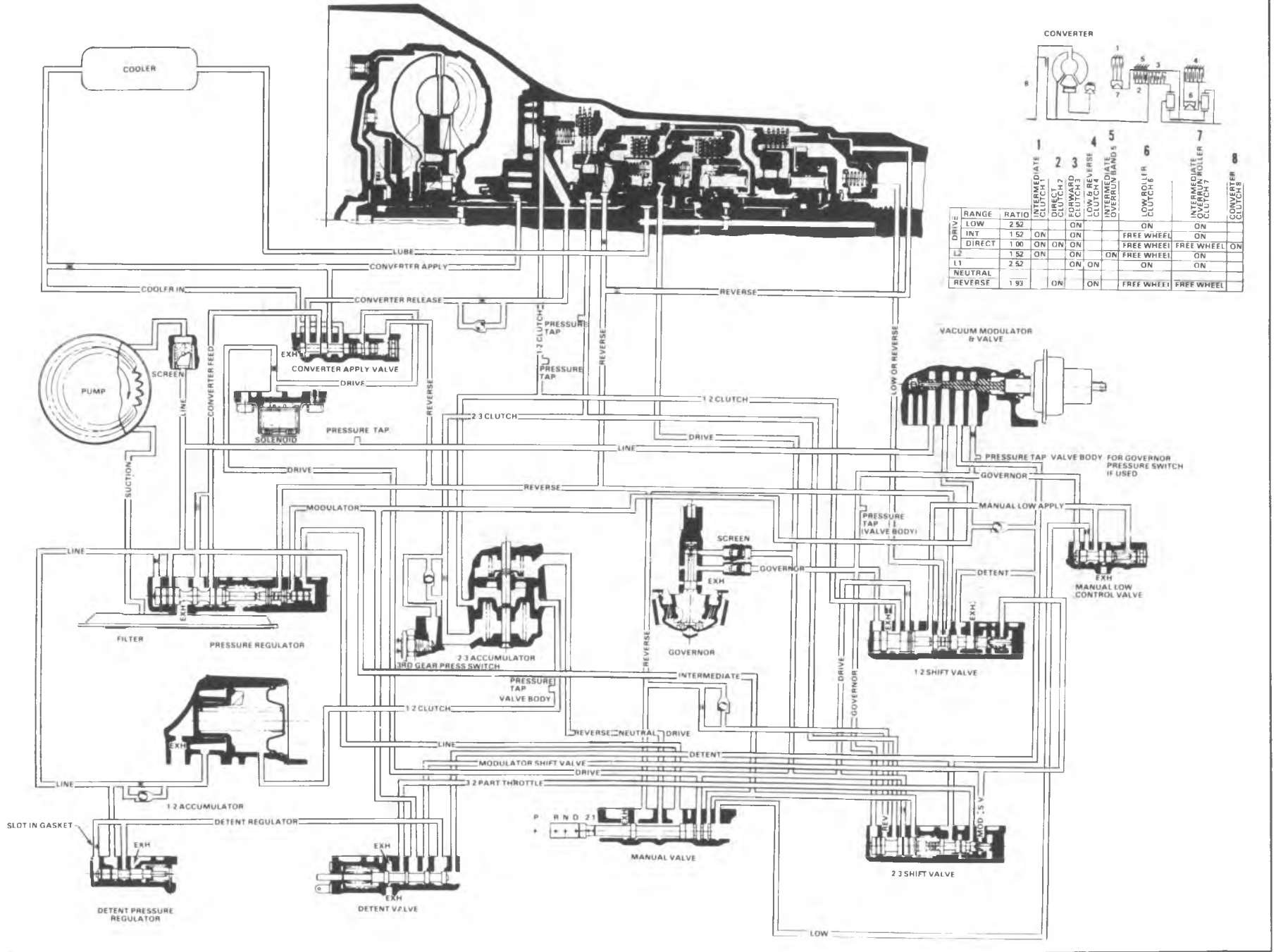

Figure 350C-6 Neutral - Engine Running

350 AUTOMATIC TRANSMISSION  
DIAGNOSIS CHART

| PROBLEM                       | CAR ROAD TEST  |                         |                       |                        |                            |                           |                           |                          |                |                     |                   |                   |                |                     |                   |                   |                    |                        |                        |                         |                  |                          |                          |                           |                    |                  |                       |                  |                     |                         |                 |                        |  |  |  |  |   |
|-------------------------------|--|-------------------------|-----------------------|------------------------|----------------------------|---------------------------|---------------------------|--------------------------|----------------|---------------------|-------------------|-------------------|----------------|---------------------|-------------------|-------------------|--------------------|------------------------|------------------------|-------------------------|------------------|--------------------------|--------------------------|---------------------------|--------------------|------------------|-----------------------|------------------|---------------------|-------------------------|-----------------|------------------------|--|--|--|--|---|
|                               | LEGEND<br>X—PROBLEM AREA V.S. CAUSE<br>*—@ "O" VACUUM ONLY<br>O—BALLS #2/3/4 ONLY<br>L—LOCKED<br>S—STUCK |                         |                       |                        |                            |                           |                           |                          |                |                     |                   |                   |                |                     |                   |                   |                    |                        |                        |                         |                  |                          |                          |                           |                    |                  |                       |                  |                     |                         |                 |                        |  |  |  |  |   |
| POSSIBLE CAUSE                | ALL RANGES—SLIPS   | DRIVE—SLIPS—NO 1ST GEAR | LINE PRESSURE—ALL LOW | LINE PRESSURE—ALL HIGH | 1-2 INTERM. CL. PRES. HIGH | 1-2 INTERM. CL. PRES. LOW | 2-3 DIRECT CL. PRES. HIGH | 2-3 DIRECT CL. PRES. LOW | NO 1-2 UPSHIFT | 1-2 U.S. EARLY/LATE | SLIPS—1-2 UPSHIFT | ROUGH—1-2 UPSHIFT | NO 2-3 UPSHIFT | 2-3 U.S. EARLY/LATE | SLIPS—2-3 UPSHIFT | ROUGH—2-3 UPSHIFT | NO WOT 1-2 UPSHIFT | NO—PART TH. DOWN SHIFT | NO—FULL TH. DOWN SHIFT | 2-3 UPSHIFT—W.O.T. ONLY | HARSH—DOWN SHIFT | L1 RANGE—NO ENG. BRAKING | L2 RANGE—NO ENG. BRAKING | NEUTRAL—DRIVES IN NEUTRAL | REVERSE—NO REVERSE | SLIPS IN REVERSE | PARK—NO PARK RATCHETS | NOISY—ALL RANGES | 1-2 2-3 SHIFT NOISY | REV. & D. L1 & L2 NOISY | LOW COOLER—FLOW | SPEWS OIL OUT BREATHER |  |  |  |  |   |
| LOW OIL LEVEL/WATER IN OIL    | X  | X                       | X                     |                        | X                          | X                         |                           |                          | X              |                     |                   | X                 |                |                     |                   |                   |                    |                        |                        |                         |                  |                          |                          |                           | X                  | X                | X                     | X                | X                   |                         |                 |                        |  |  |  |  |   |
| VACUUM LEAK                   |  |                         |                       | X                      | X                          | X                         |                           |                          | X              | X                   | X                 | X                 |                |                     |                   |                   | X                  |                        |                        |                         |                  |                          |                          |                           |                    |                  |                       |                  |                     |                         |                 |                        |  |  |  |  |   |
| MODULATOR & / OR VALVE        | X  | X                       | *                     | X                      | X                          |                           |                           |                          |                |                     |                   | X                 | X              | X                   | X                 |                   |                    |                        |                        |                         |                  |                          |                          |                           | X                  |                  |                       |                  |                     |                         |                 |                        |  |  |  |  |   |
| STRAINER & / OR GASKET        | X  | X                       | X                     |                        | X                          |                           | X                         |                          |                |                     |                   |                   |                |                     |                   |                   |                    |                        |                        |                         |                  |                          |                          | X                         | X                  |                  |                       |                  |                     |                         |                 |                        |  |  |  |  |   |
| GOVERNOR—VALVE/SCREEN         |  |                         | X                     | X                      |                            |                           |                           | X                        | X              |                     |                   |                   | X              |                     |                   |                   |                    |                        |                        |                         |                  |                          |                          |                           |                    | X                | X                     |                  |                     |                         |                 |                        |  |  |  |  |   |
| VALVE BODY—GASKET/PLATE       | X  | X                       | X                     |                        | X                          | X                         | X                         | X                        | X              | X                   | X                 | X                 | X              | X                   |                   |                   |                    |                        |                        |                         |                  |                          |                          | X                         | X                  |                  |                       |                  |                     |                         |                 |                        |  |  |  |  |   |
| PRES. REG. & / OR BOOST VALVE | X  | X                       | X                     | X                      | X                          | X                         | X                         | X                        | X              | X                   | X                 | X                 | X              | X                   |                   |                   |                    |                        |                        |                         |                  |                          | X                        | X                         |                    | X                | X                     |                  |                     |                         |                 |                        |  |  |  |  |   |
| BALL (#1) SHY                 | X  | X                       | *                     |                        | X                          |                           |                           | X                        | X              | X                   | X                 |                   |                |                     |                   |                   |                    |                        |                        |                         |                  |                          |                          |                           |                    |                  |                       |                  |                     |                         |                 |                        |  |  |  |  |   |
| 1-2 SHIFT VALVE               |  |                         |                       |                        | X                          |                           |                           | X                        | X              | X                   | X                 |                   |                |                     |                   |                   |                    |                        |                        |                         |                  |                          |                          |                           |                    |                  |                       |                  |                     |                         |                 |                        |  |  |  |  |   |
| 2-3 SHIFT VALVE               |  |                         |                       |                        |                            |                           | X                         |                          | X              | X                   | X                 | X                 | X              | X                   |                   |                   | X                  |                        |                        |                         |                  |                          |                          |                           |                    |                  |                       |                  |                     |                         |                 |                        |  |  |  |  |   |
| MANUAL LOW CONT'L VALVE       |  |                         |                       |                        |                            |                           |                           |                          |                |                     |                   |                   |                |                     |                   |                   |                    |                        |                        |                         |                  |                          |                          |                           |                    |                  |                       |                  |                     |                         |                 |                        |  |  |  |  |   |
| DETENT VALVE & LINKAGE        |  |                         |                       | X                      |                            |                           |                           |                          |                |                     |                   |                   | X              |                     |                   |                   | X                  | X                      | X                      |                         |                  |                          |                          |                           |                    |                  |                       |                  |                     |                         |                 |                        |  |  |  |  |   |
| DETENT REG. VALVE             |  |                         |                       |                        |                            |                           |                           |                          |                |                     |                   |                   |                |                     |                   |                   |                    |                        |                        |                         |                  |                          |                          |                           |                    |                  |                       |                  |                     |                         |                 |                        |  |  |  |  |   |
| 2-3 ACCUMULATOR               |  |                         |                       |                        | X                          |                           |                           |                          |                |                     | X                 |                   |                |                     | X                 |                   |                    |                        |                        |                         |                  |                          |                          |                           |                    |                  |                       |                  |                     |                         |                 |                        |  |  |  |  |   |
| MANUAL VALVE/LINKAGE          | X  | X                       | X                     |                        |                            |                           |                           |                          |                |                     |                   |                   |                |                     |                   |                   |                    |                        |                        |                         |                  |                          |                          |                           |                    |                  |                       |                  |                     |                         |                 |                        |  |  |  |  |   |
| POROSITY/CROSS LEAK           | X  | X                       | X                     | X                      | X                          | X                         | X                         | X                        | X              | X                   | X                 | X                 | X              | X                   | X                 | X                 | X                  | X                      | X                      |                         |                  |                          |                          |                           |                    |                  |                       |                  |                     |                         |                 |                        |  |  |  |  |   |
| PUMP—GEARS                    | X  | X                       | X                     |                        | X                          | X                         |                           |                          |                |                     | X                 |                   |                | X                   |                   |                   |                    |                        |                        |                         |                  |                          |                          |                           |                    |                  |                       |                  |                     |                         |                 |                        |  |  |  |  |   |
| PRIMING VALVE SHY             | X  | X                       | X                     |                        |                            |                           |                           |                          |                |                     |                   |                   |                |                     |                   |                   |                    |                        |                        |                         |                  |                          |                          |                           |                    |                  |                       |                  |                     |                         |                 |                        |  |  |  |  | S |
| COOLER VALVE LEAK             |  |                         |                       |                        |                            |                           |                           |                          |                |                     |                   |                   |                |                     |                   |                   |                    |                        |                        |                         |                  |                          |                          |                           |                    |                  |                       |                  |                     |                         |                 |                        |  |  |  |  | X |
| CLUTCH SEAL RINGS             | X  | X                       | X                     |                        | X                          | X                         | X                         |                          |                | X                   | X                 | X                 |                |                     |                   |                   |                    |                        |                        |                         |                  |                          |                          |                           |                    |                  |                       |                  |                     |                         |                 |                        |  |  |  |  | X |
| POROUS/CROSS LEAK             | X  | X                       | X                     |                        | X                          | X                         | X                         |                          |                | X                   | X                 | X                 | X              | X                   |                   |                   |                    |                        |                        |                         |                  |                          |                          |                           |                    |                  |                       |                  |                     |                         |                 |                        |  |  |  |  | X |
| GASKET SCREEN—PRESSURE        | X  | X                       | X                     |                        |                            |                           |                           |                          |                |                     |                   |                   |                |                     |                   |                   |                    |                        |                        |                         |                  |                          |                          |                           |                    |                  |                       |                  |                     |                         |                 |                        |  |  |  |  | X |
| BAND—INTERM. O.R.             |  |                         |                       |                        |                            |                           |                           |                          |                |                     |                   |                   |                |                     |                   |                   |                    |                        |                        |                         |                  |                          |                          |                           |                    |                  |                       |                  |                     |                         |                 |                        |  |  |  |  |   |
| CASE—POROUS/X LEAK            | X  | X                       | X                     | X                      | X                          | X                         | X                         | X                        | X              | X                   | X                 | X                 | X              | X                   | X                 | X                 | X                  | X                      | X                      |                         |                  |                          |                          |                           |                    |                  |                       |                  |                     |                         |                 |                        |  |  |  |  | X |
| 1-2 ACCUMULATOR               | X  | X                       | X                     |                        | X                          |                           |                           |                          |                |                     | X                 | X                 |                |                     |                   |                   |                    |                        |                        |                         |                  |                          |                          |                           |                    |                  |                       |                  |                     |                         |                 |                        |  |  |  |  |   |
| INTERMED. SERVO               |  | X                       | X                     |                        | X                          |                           |                           |                          |                |                     | X                 |                   |                |                     |                   |                   |                    |                        |                        |                         |                  |                          |                          |                           |                    |                  |                       |                  |                     |                         |                 |                        |  |  |  |  |   |
| FORWARD CLUTCH ASS'Y          |  | X                       |                       |                        |                            |                           |                           |                          |                |                     |                   |                   |                |                     |                   |                   |                    |                        |                        |                         |                  |                          |                          |                           |                    |                  |                       |                  |                     |                         |                 |                        |  |  |  |  |   |
| DIRECT CLUTCH ASS'Y           |  |                         |                       |                        |                            | X                         |                           |                          |                |                     |                   |                   | X              | X                   |                   |                   |                    |                        |                        |                         |                  |                          |                          |                           |                    |                  |                       |                  |                     |                         |                 |                        |  |  |  |  |   |
| INTERMED. CL. ASS'Y           |  |                         |                       |                        | X                          |                           | X                         |                          |                | X                   |                   |                   |                |                     |                   |                   |                    |                        |                        |                         |                  |                          |                          |                           |                    |                  |                       |                  |                     |                         |                 |                        |  |  |  |  | X |
| L & REV. CL. ASS'Y            |  |                         |                       |                        |                            |                           |                           |                          |                |                     |                   |                   |                |                     |                   |                   |                    |                        |                        |                         |                  |                          |                          |                           |                    |                  |                       |                  |                     |                         |                 |                        |  |  |  |  |   |
| INT. ROLLER CL. ASS'Y         |  |                         |                       |                        |                            |                           | X                         |                          |                | X                   |                   |                   |                |                     |                   |                   |                    |                        |                        |                         |                  |                          |                          |                           |                    |                  |                       |                  |                     |                         |                 |                        |  |  |  |  |   |
| L. & R. ROLLER CL. ASS'Y      |  | X                       |                       |                        |                            |                           |                           |                          |                |                     |                   |                   |                |                     |                   |                   |                    |                        |                        |                         |                  |                          |                          |                           |                    |                  |                       |                  |                     |                         |                 |                        |  |  |  |  |   |
| PARK PAWL/LINKAGE             |  |                         |                       |                        |                            |                           |                           |                          |                |                     |                   |                   |                |                     |                   |                   |                    |                        |                        |                         |                  |                          |                          |                           |                    |                  |                       |                  |                     |                         |                 |                        |  |  |  |  |   |
| CONVERTER ASS'Y               |  |                         |                       |                        |                            |                           |                           |                          |                |                     |                   |                   |                |                     |                   |                   |                    |                        |                        |                         |                  |                          |                          |                           |                    |                  |                       |                  |                     |                         |                 |                        |  |  |  |  | X |
| GEAR SET & BEARINGS           |  |                         |                       |                        |                            |                           |                           |                          |                |                     |                   |                   |                |                     |                   |                   |                    |                        |                        |                         |                  |                          |                          |                           |                    |                  |                       |                  |                     |                         |                 |                        |  |  |  |  | X |

Figure 350C-7 Diagnosis Chart

9B7A22



IDENTIFICATION OF OIL CHANNELS IN PUMP COVER

1. COOLER OUT
2. EXHAUST
3. PUMP PRESSURE
4. REVERSE (DIRECT CLUTCH OUTER)
5. SUCTION
6. CONVERTER RELEASE
7. FORWARD CLUTCH (DRIVE)
8. DIRECT CLUTCH
9. INTERMEDIATE CLUTCH
10. CONVERTER CLUTCH APPLY
11. COOLER IN
12. LIP SEAL DRAIN

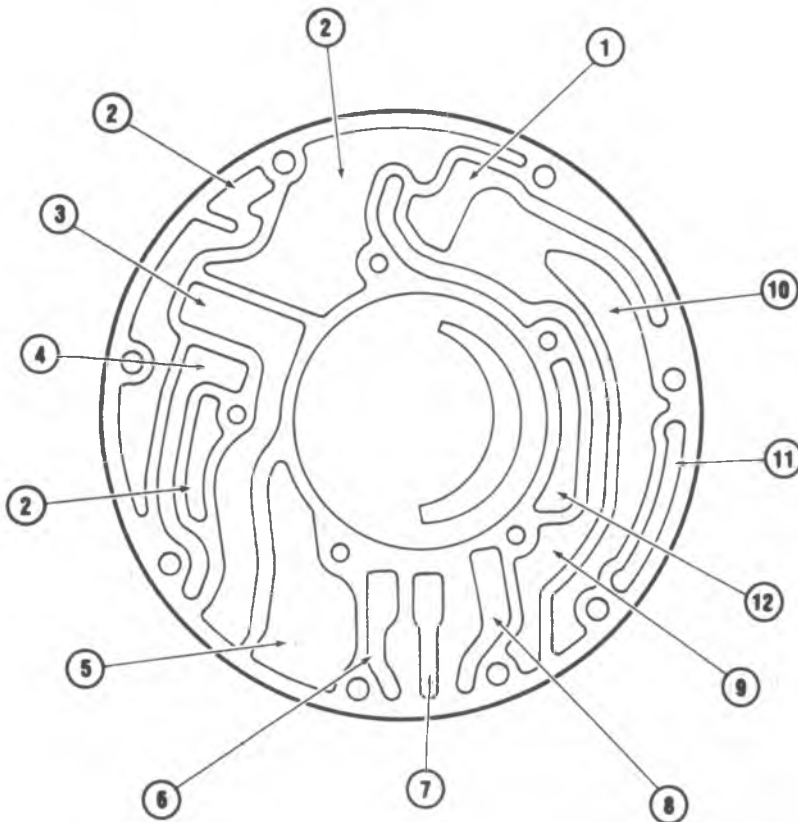

IDENTIFICATION OF OIL CHANNELS IN PUMP BODY FRONT FACE

Figure 350C-8 Identification of Oil Pump Channels

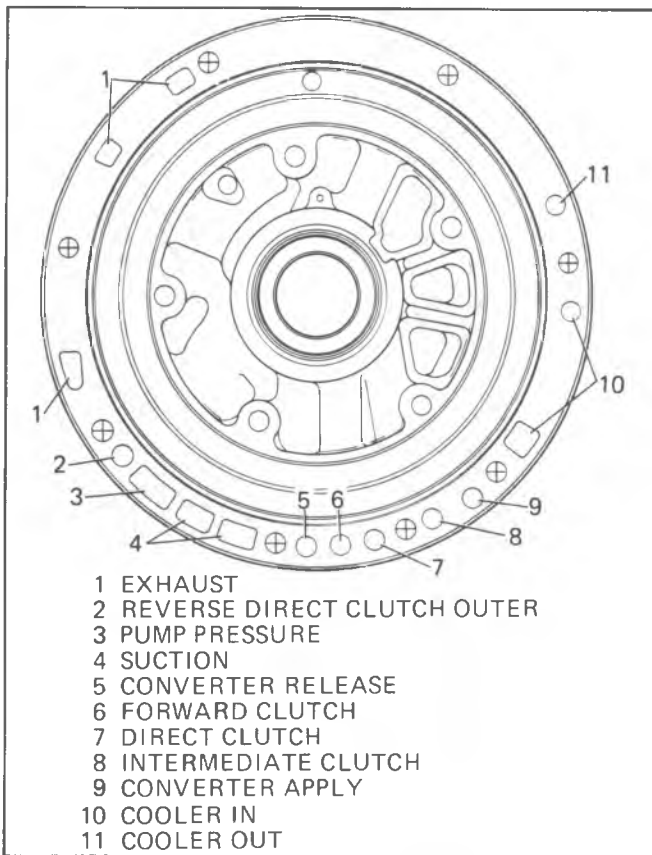
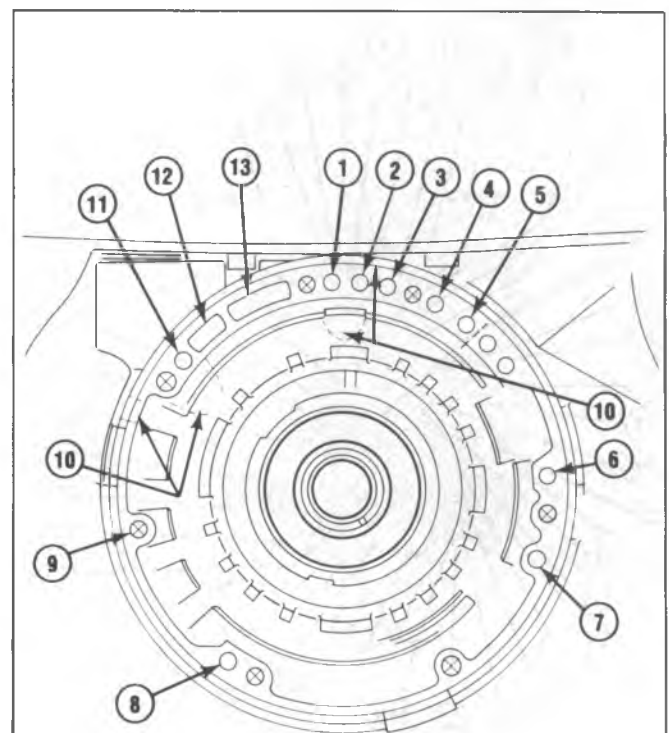

Figure 350C-9 Identification of Pump Rear Face Oil Channels



1. C. C. RELEASE
2. FWD CLUTCH
3. DIRECT CLUTCH
4. INTER CLUTCH APPLY
5. CONVERTER APPLY
6. COOLER IN (TO RADIATOR)
7. COOLER OUT (FROM RADIATOR)
8. BREATHER
9. (7) PUMP TO CASE BOLT-TAPPED HOLES
10. DRAIN (4) CAST OPEN PORTS
11. REVERSE (DIRECT CLUTCH OUTER)
12. PUMP PRESSURE
13. SUCTION

7C-56A

Figure 350C-10 Identification of Case Pump Oil Channels

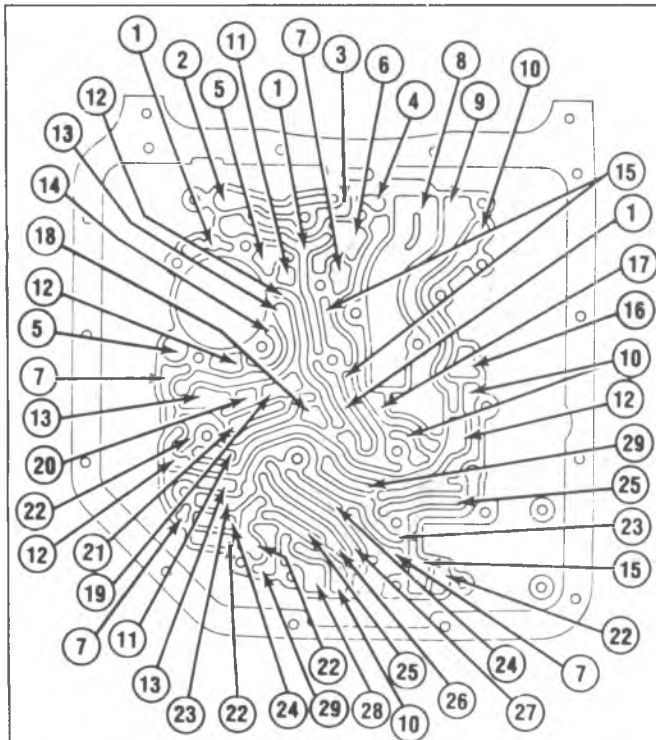

- |  |                                   |
|--|-----------------------------------|
| 1. DIRECT CLUTCH (2-3)                   | 17. CONVERTER FEED                |
| 2. COOLER IN                             | 18. EXHAUST (1-2) CLUTCH          |
| 3. CONVERTER APPLY                       | 19. MODULATOR OR DETENT REGULATOR |
| 4. CONVERTER RELEASE                     | 20. EXHAUST INTERMEDIATE CLUTCH   |
| 5. INTERMEDIATE CLUTCH (1-2)             | 21. DETENT REGULATOR              |
| 6. DRIVE FORWARD CLUTCH                  | 22. GOVERNOR                      |
| 7. DRAIN                                 | 23. MODULATOR                     |
| 8. SUCTION                               | 24. DETENT 2                      |
| 9. PUMP PRESSURE                         | 25. LOW                           |
| 10. REVERSE                              | 26. DETENT MODULATOR (3-2)        |
| 11. VOID                                 | 27. MODULATOR THRU DETENT VALVE   |
| 12. INTERMEDIATE SERVO RELEASE (R, N, D) | 28. LOW REVERSE CLUTCH            |
| 13. LINE                                 | 29. MANUAL LOW CONTROL            |
| 14. 2-3 CLUTCH                           |                                   |
| 15. DRIVE                                |                                   |
| 16. EXHAUST                              |                                   |

5B7C52A

Figure 350C-11 Identification of Case Face Oil Channels

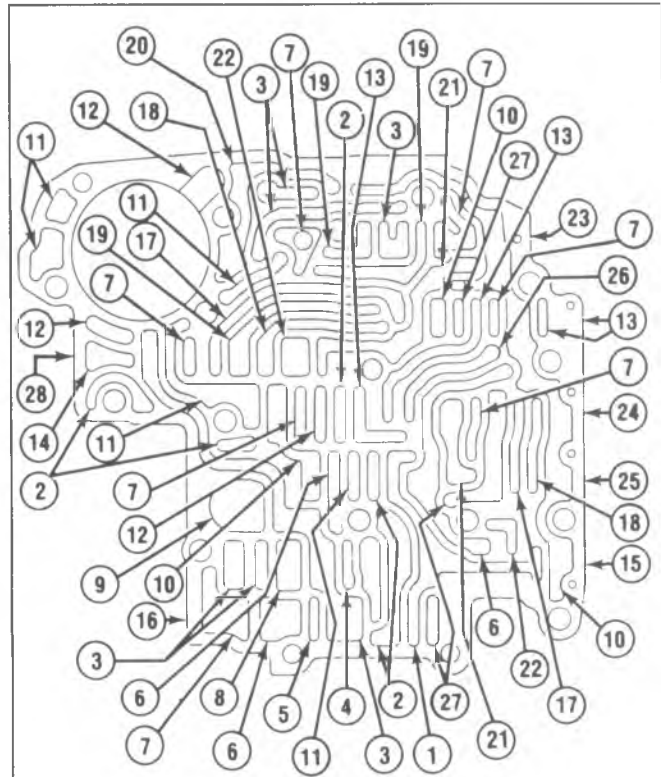

- |                                   |                                   |
|-----------------------------------|-----------------------------------|
| 1. INTERMEDIATE (L <sub>2</sub> ) | 17. DETENT 1                      |
| 2. DRIVE                          | 18. MODULATOR OR DETENT REGULATOR |
| 3. LINE                           | 19. DETENT REGULATOR              |
| 4. CONVERTER FEED                 | 20. INTERMEDIATE SERVO RELEASE    |
| 5. SPEED RELEASE                  | 21. DETENT 2                      |
| 6. REVERSE                        | 22. MODULATOR                     |
| 7. EXHAUST                        | 23. DETENT PRESSURE REGULATOR     |
| 8. EXHAUST OPEN TO SUMP           | 24. 1-2 SHIFT                     |
| 9. SUCTION                        | 25. 2-3 SHIFT                     |
| 10. GOVERNOR                      | 26. LOW OR REVERSE                |
| 11. 2-3 CLUTCH                    | 27. LOW                           |
| 12. 1-2 CLUTCH                    | 28. DETENT                        |
| 13. MANUAL LOW CONTROL            |                                   |
| 14. VOID                          |                                   |
| 15. PRESSURE REGULATOR            |                                   |
| 16. MANUAL                        |                                   |

5B7C50A

Figure 350C-12 Identification of Valve Body Oil Channels

## 350 TROUBLE DIAGNOSIS CHART

| Condition                                 | Possible Cause                | Correction  |
|---|-------------------------------|---|
| No drive range - (install pressure gage). | 1. Low oil level.             | 1. Correct level - check for external leaks or vacuum modulator (leaking diaphragm will evacuate oil from unit).  |
|   | 2. Manual Linkage adjustment. | 2. See Manual linkage adjustment.   |
|   | 3. Low oil pressure.          | 3a. Filter assembly - blocked.<br>b. Pump assembly - pressure regulator, pump drive gear - tangs damaged by converter.<br>c. Case - porosity in intake bore.  |
|   | 4. Control valve assembly.    | 4. Manual valve disconnected from inner lever.  |
|   | 5. Forward clutch.            | 5a. Forward clutch does not apply - piston cracked; seals missing, damaged; clutch plates burned.<br>b. Pump feed circuit to forward clutch oil seal rings missing or broken on pump cover; leak in feed circuits; pump to case gasket mispositioned or damaged. Clutch drum ball check stuck or missing. |
|   | 6. Roller clutch assembly.    | 6. Broken spring or damaged cage.   |
| Oil pressure high<br>low                  | 1. High oil pressure.         | 1a. Vacuum line or fittings leaking.<br>b. Vacuum modulator.<br>c. Modulator valve.<br>d. Pressure regulator.<br>e. Oil pump.   |
|   | 2. Low oil pressure.          | 2a. Vacuum line or fittings obstructed.<br>b. Vacuum modulator.<br>c. Modulator valve.<br>d. Pressure regulator.<br>e. Governor.<br>f. Oil pump.  |
| 1-2 shift - full throttle only.           | 1. Detent valve misadjusted.  | 1. Sticking or linkage  |
|   | 2. Vacuum leak.               | 2. Vacuum line or fittings leaking.   |
|   | 3. Control valve assembly.    | 3a. Valve body gaskets - leaking, damaged, incorrectly installed.<br>b. Detent valve train stuck.<br>c. 1-2 valve stuck.  |
|   | 4. Case assembly.             | 4. Porosity.  |



## 350C-10 AUTOMATIC TRANSMISSION

---

First speed only - no  
1-2 shift.

1. Governor assembly.

1a. Governor valve sticking.  
b. Driven gear loose, damaged  
or worn (check for pin  
in case and length of  
pin showing); also,  
check output shaft drive  
gear for nicks or rough  
finish, if driven gear shows  
damage..

2. Control valve as-  
sembly.

2a. 1-2 shift valve train  
stuck closed.  
b. Governor feed channels  
blocked.  
c. Valve body gaskets -  
leaking, damaged, incor-  
rectly installed.

3. Case

3a. Porosity between  
channels.  
b. Governor feed channel  
blocked, governor bore  
scored or worn, allowing  
cross pressure leak.

4. Intermediate clutch.

4a. Clutch piston seals -  
missing, improperly as-  
sembled, cut.  
b. Intermediate roller  
clutch.  
Broken spring or damaged  
cage.

---

First and second  
speeds only, no 2-3  
shift.

1. Control valve as-  
sembly.

1a. 2-3 shift train stuck.  
b. Valve body gaskets -  
leaking, damaged, incor-  
rectly installed.

2. Direct clutch.

2a. Pump hub - direct clutch  
oil seal rings - broken,  
missing.  
b. Clutch piston seals -  
missing, improperly as-  
sembled, cut, piston ball  
check stuck or missing.

---

Drive in "Neutral".

1. Manual linkage.  
2. Forward clutch.

1. Misadjusted  
2. Clutch does not release -  
(this condition will also  
cause "No Reverse").

---

No motion in "Reverse",  
or slips in "Reverse"  
- (install pressure  
gage).

1. Low oil level.

1. Add oil.

2. Manual linkage.  
3. Oil pressure.

2. Misadjusted.  
3a. Modulator valve stuck.  
b. Modulator and reverse  
boost valve stuck.  
c. Pump hub - direct clutch  
oil seal rings broken,  
missing.  
d. Direct clutch piston seal  
cut or missing.  
e. Low and reverse clutch  
piston seal cut or missing.  
f. No. 1 check ball missing.  
4a. Valve body gaskets -

4. Control valve as-

|  |   |  |
|--|---|--|
|  | <p>sembly.</p> <p>5. Intermediate servo.</p> <p>6. Low and reverse clutch.</p> <p>7. Direct clutch.</p> <p>8. Forward clutch.</p>   | <p>leaking, damaged, incorrectly installed (other malfunctions may also be indicated).</p> <p>b. 2-3 valve train stuck in upshifted position. This will also cause 1-3 upshift in drive range.</p> <p>c. 1-2 valve train stuck in upshifted position.</p> <p>5a. Piston or pin stuck so intermediate overrun band is applied.</p> <p>6. Piston out or seal damaged or missing.</p> <p>7a. Outer seal damaged or missing.</p> <p>b. Clutch plates burned - may be caused by stuck ball check in piston.</p> <p>8. Clutch does not release (will also cause "Drive" in "Neutral").</p> |
| <p>Slips in all ranges, slips on take-off - (install pressure gage).</p> | <p>1. Oil level low.</p> <p>2. Oil pressure.</p> <p>3. Case</p> <p>4. Forward clutch slipping.</p>  | <p>1. Add oil.</p> <p>2a. Vacuum modulator inoperative.</p> <p>b. Vacuum modulator valve sticking.</p> <p>c. Filter assembly - plugged or leaks.</p> <p>3a. Pressure regulator valve stuck.</p> <p>b. Pump to case gasket damaged or incorrectly installed.</p> <p>4. Cross leaks, porosity.</p>   |
| <p>Slips 1-2 shift - (install pressure gage).</p>                        | <p>1. Oil level low.</p> <p>2. Oil pressure.</p> <p>3. 2-3 accumulator.</p> <p>4. 1-2 accumulator.</p> <p>5. Pump to case gasket.</p> <p>6. Case</p> <p>7. Intermediate clutch.</p> | <p>1. Add oil.</p> <p>2a. Vacuum modulator assembly inoperative.</p> <p>b. Modulator valve sticking.</p> <p>c. Pump pressure regulator valve.</p> <p>3. Oil ring damaged or missing.</p> <p>4. Oil ring missing or damaged, case bore damaged.</p> <p>5. Mispositioned</p> <p>6. Porosity between channels.</p> <p>7. Piston seals missing or damaged; clutch plates burned.</p>   |

## 350C-12 AUTOMATIC TRANSMISSION

---

Rough 1-2 shift -  
(install pressure  
gage).

1. Oil pressure.  
for loose fittings, re-  
strictions in line.

- 1a. Vacuum modulator - check

2. Case
3. 1-2 accumulator  
assembly.

- b. Modulator valve stuck.
  - c. Valve body - regulator  
or boost valve stuck.
  - d. Pump to case gasket -  
off location or damaged.
  2. Porosity between channels.
  - 3a. Oil rings damaged.
  - b. Piston stuck.
  - c. Broken or missing spring.
  - d. Bore damaged.
  - e. Check accumulator feed  
hole in valve body plate.
- 

Slips 2-3 shift -  
(install pressure  
gage).

1. Oil level low.
2. Oil pressure low.
3. Case
4. Direct clutch.

1. Add oil.
  - 2a. Modulator assembly.
  - b. Modulator valve.
  - c. Pump pressure regulator  
valve or boost valve; pump  
to case gasket off location.
  3. Porosity
  4. Piston seals leaking,  
or ball check leak.
- 

Rough 2-3 shift -  
(install pressure  
gage).

1. Oil pressure high
2. 2-3 accumulator  
assembly.

- 1a. Vacuum leak.
  - b. Modulator valve sticking.
  - c. Valve body - pressure  
regulator or boost valve  
inoperative.
  - 2a. 2-3 accumulator spring  
missing, broken.
  - b. Accumulator piston stuck.
- 

No engine braking -  
L2 - 2nd gear.

1. Intermediate servo  
and 2-3 accumulator.
2. Intermediate overrun  
band.
3. Oil pressure low.

- 1a. Servo or accumulator  
oil rings or bores leaking.
  - b. Servo piston stuck.
  2. Intermediate overrun  
band broken, burned (check  
for cause).
  3. Pressure regulator and/or  
boost valve stuck.
- 

No engine braking -  
L-1 - 1st gear.

1. Manual low control  
valve assembly.
2. Oil pressure low.
3. Low and reverse  
clutch.

1. Stuck
  2. Pressure regulator and/or  
boost valve stuck.
  3. Piston inner seal  
damaged or missing.
- 

No part throttle down-  
shift - (install pres-  
sure gage).

1. Oil pressure.
2. Detent valve and  
linkage.
3. 2-3 shift valve.

1. Vacuum modulator as-  
sembly, modulator valve,  
pressure regulator valve  
train (other malfunctions  
may also be noticed).
2. Sticks or disconnected  
or broken.
3. Stuck

|   |   |   |
|---|---|---|
| No detent downshifts.                               | <ol style="list-style-type: none"> <li>1. Control valve assembly.</li> <li>2. Detent valve and linkage.</li> </ol>  | <ol style="list-style-type: none"> <li>1. 2-3 valve stuck.</li> <li>2. Sticks or disconnected or broken.</li> </ol>   |
| Low or high shift points - (install pressure gage). | <ol style="list-style-type: none"> <li>1. Oil pressure.</li> <li>2. Governor</li> <li>3. Detent valve and linkage.</li> <li>4. Control valve assembly.</li> <li>5. Case</li> </ol>  | <ol style="list-style-type: none"> <li>1a. Engine vacuum - check at transmission end of the modulator pipe.</li> <li>b. Vacuum modulator assembly vacuum line connections at engine and transmission, modulator valve, pressure regulator valve train.             <ol style="list-style-type: none"> <li>2a. Valve sticking.</li> <li>b. Feed holes restricted or leaking, pipes damaged or mispositioned.</li> <li>c. Feed line plugged.</li> </ol> </li> <li>3. Stuck open. (Will cause late shifts).</li> <li>4a. 2-3 valve train sticking.</li> <li>b. 1-2 shift valve train sticking.</li> <li>5. Porosity</li> </ol> |
| Won't hold in "Park".                               | <ol style="list-style-type: none"> <li>1. Manual linkage.</li> <li>2. Internal linkage.</li> </ol>  | <ol style="list-style-type: none"> <li>1. Misadjusted             <ol style="list-style-type: none"> <li>2a. Parking brake lever and actuator assembly. Check for chamfer on actuator rod sleeve.</li> <li>b. Parking pawl broken or inoperative.</li> </ol> </li> </ol>  |
| Locks up in manual low (usually hot only).          | <ol style="list-style-type: none"> <li>1. Converter pressure leaking into direct clutch thru stator shaft.</li> <li>2. Direct clutch.</li> <li>3. Lo and Reverse Clutch.</li> </ol> | <ol style="list-style-type: none"> <li>1. Check stator shaft position.</li> <li>2a. Direct clutch bore undersize or piston oversize.</li> <li>b. Direct clutch feed hole shy small chamber.</li> <li>3. Lo and Reverse Clutch piston center seal missing or cut.</li> </ol>   |
| Second gear start or slips second gear only.        | <ol style="list-style-type: none"> <li>1. Intermediate clutch.</li> </ol>   | <ol style="list-style-type: none"> <li>1. Wrong number of clutch plates or wrong piston.</li> </ol>   |
| Locks up in reverse (usually hot only).             | <ol style="list-style-type: none"> <li>1. Forward clutch.</li> <li>2. Direct clutch.</li> </ol>   | <ol style="list-style-type: none"> <li>1. Bore undersize or piston oversize.</li> <li>2. Direct clutch feeding forward clutch thru stator shaft. (check stator shaft position.)</li> </ol>  |
| Locks in reverse from park to reverse only.         | <ol style="list-style-type: none"> <li>1. Parking pawl.</li> </ol>  | <ol style="list-style-type: none"> <li>1. Parking pawl staying in due to a burr on leading edge.</li> </ol>   |
| Cold morning reverse no drive till engine warms up. | <ol style="list-style-type: none"> <li>1. Pressure regulator bore or sleeve tight.</li> </ol>   | <ol style="list-style-type: none"> <li>1. Remove and repair.</li> </ol>   |

## 350C-14 AUTOMATIC TRANSMISSION

|  |  |  |
|--|--|--|
| Shifts cold but not warm.  | 1. Governor assembly.                      | 1. Nylon gear roll pin shy.  |
| No drive-but has manual low.   | 1. Low & reverse roller clutch.            | 1. Low & reverse roller clutch installed backwards.  |
| No 1-2 shift-makes 1-3 shift and 3-1 shift, but has all shifts manually. | 1. Intermediate roller clutch.             | 1. Intermediate roller clutch not locking.   |
| Governor nylon gear stripped 360°.                                       | 1. Case pin. missing.<br>2. Output shaft.  | 1. Governor case pin<br>2. Output shaft rough or worn.   |
| Governor gear stripped one sided.  | 1. Governor sizing in bore.                | 1. Repair or replace as necessary.   |
| Slow reverse (cold only).  | 1. Low oil level.                          | 1. Adjust oil level.   |
| Harsh 1-2 shift.   | 1. 1-2 accumulator.                        | 1a. Piston or spring.<br>b. Accumulator feed hole in valve body plate.   |
| Slow reverse (hot only).   | 1. Valve body.<br>2. Shift selector lever. | 1a. Leaking valve body support plate.<br>2a. Bent or S-hook hole off location.<br>b. S-hook bent.<br>c. Detent roller spring hole off location.<br>d. Manual valve S-hook hole off location. |

## UNIT REPAIR

### EXTERNAL PARTS

#### Removal and Inspection

1. Place transmission in Fixture J-8763. Do not overtighten. See Figure 350C-27.
2. With transmission in Holding Fixture J-8763, remove torque converter assembly. It may be necessary to pry the converter with a screwdriver due to a suction condition caused by the input shaft "O" ring.
3. Refer to Section 7A for converter diagnosis and service information.

#### For Transmission Serial Number Information Refer to 0A Section.

4. Remove modulator assembly attaching bolt and retainer.
5. Remove vacuum modulator assembly "O" ring seal and modulator valve from case. See Figure 350C-31.
6. Inspect modulator "O" ring seal for nicks, cuts or damage. Replace if necessary.
7. Refer to Section 7A for vacuum modulator diagnosis and service information.

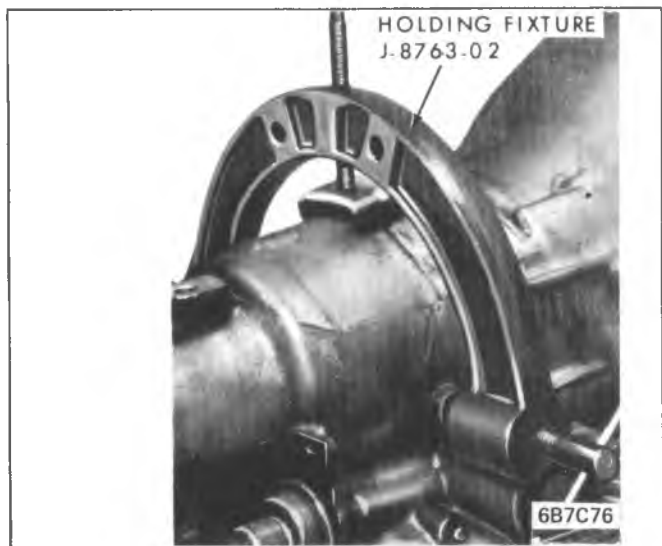

Figure 350C-27 Transmission Holding Fixture

### Removal of Extension Housing

8. Remove bolt retainer and speedometer driven gear from side of extension housing and remove four (4) extension housing to case attaching bolts. See Figure 350C-32.

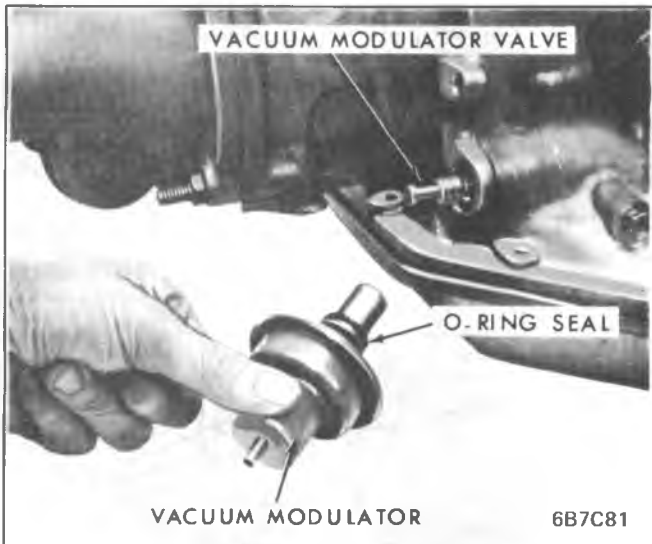

Figure 350C-31 Vacuum Modulator

9. Remove speedometer drive gear and retaining clip.
10. Inspect gear teeth for nicks, burrs or damage.

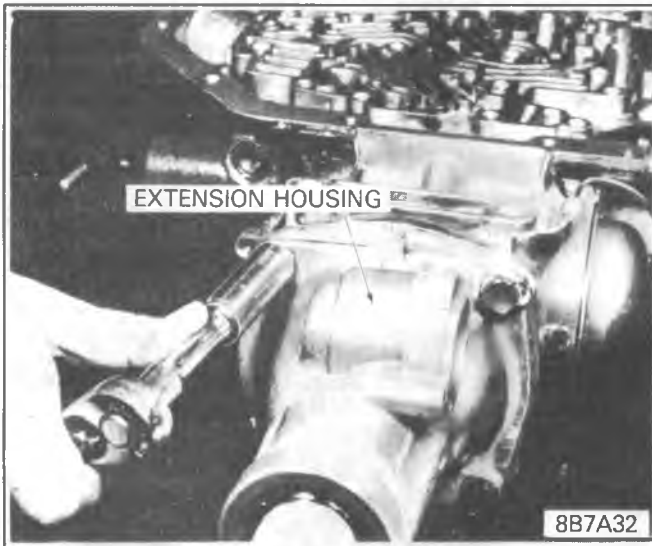

Figure 350C-32 Extension Housing Removal

11. Remove extension housing to case oil seal. See Figure 350C-33.
12. Remove the extension housing lip seal using a screwdriver. See Figure 350C-34.
13. Remove oil pan and pan gasket.
14. Remove filter assembly and filter gasket.

### Removal of Valve Body

15. Remove detent roller and spring assembly from valve body. See Figure 350C-35A.
16. Remove actuator pin from detent valve actuator lever assembly. Remove detent control link.
17. Disconnect solenoid wires. Remove pressure switch only if replacement is necessary.
18. Remove solenoid attaching bolts and solenoid. Inspect solenoid wires for loose connections and cut or worn insulator.
19. Remove manual shaft retaining clip with screwdriver and slide manual shaft outward. This will allow the control valve "S" link to be removed. (Figure 350C-36)
20. Remove valve body attaching bolts and valve body.



Figure 350C-33 Extension Housing Square Cut Oil Seal

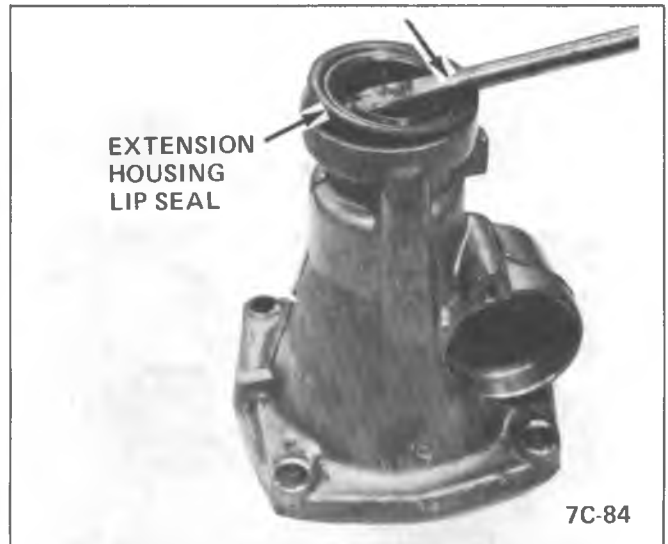

Figure 350C-34 Extension Housing Lip Seal Removal

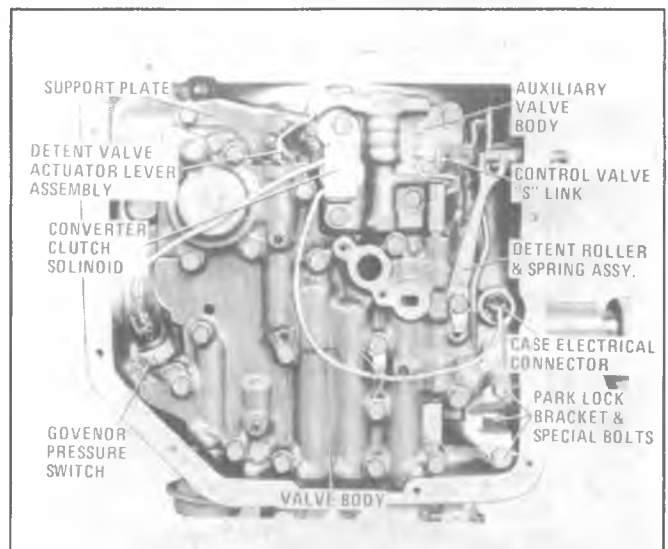

Figure 350C-35A Valve Body and Related Components

21. Remove auxiliary valve body attaching bolts and auxiliary valve body. (Figure 350C-37A)

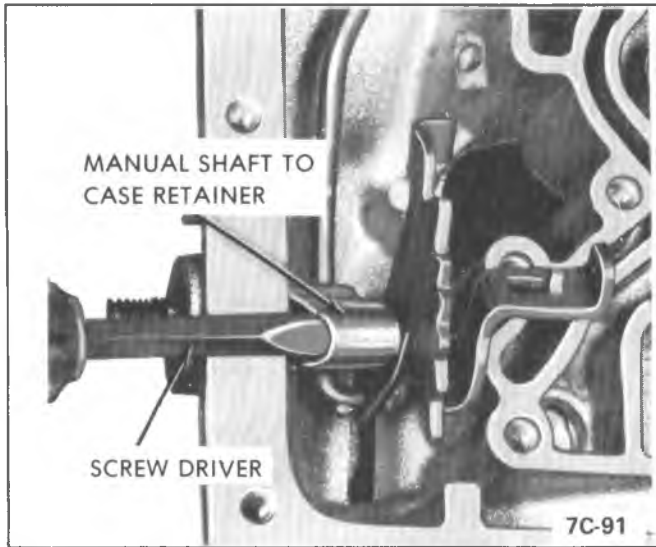

Figure 350C-36 Removing Manual Shaft Retainer

22. Remove support plate attaching bolts and support plate.

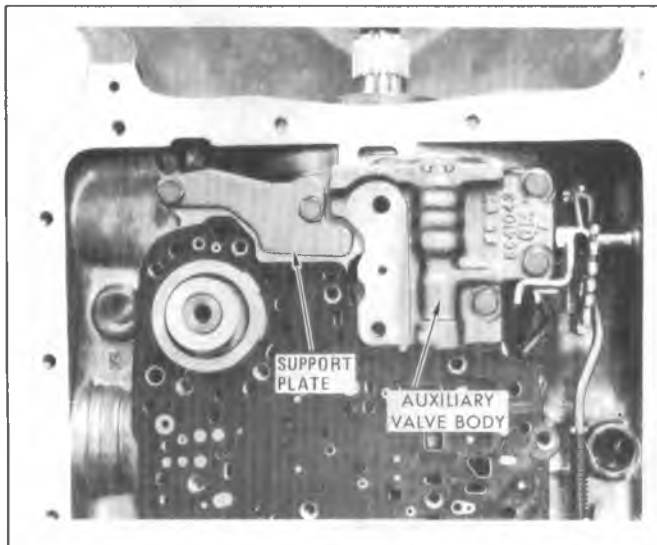

Figure 350C-37A Auxiliary Valve Body and Support Plate

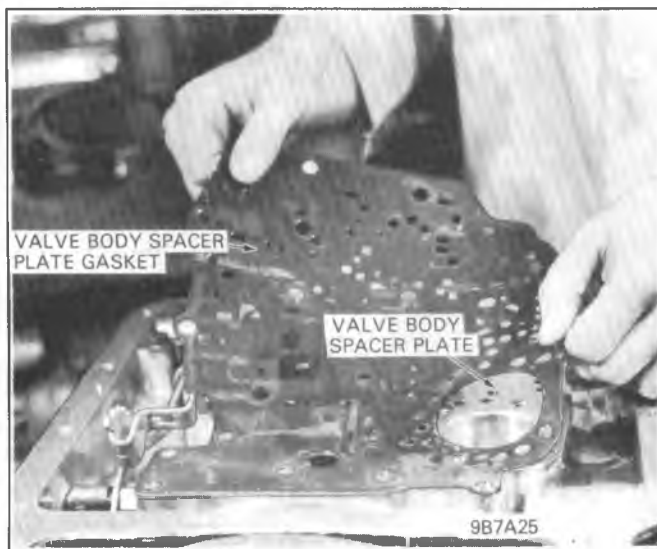

Figure 350C-38 Valve Body and Spacer Plate Gasket

23. Remove spacer plate and gaskets. (Figure 350C-38). The spacer plate to valve body has a gasket with a yellow ink stripe. The yellow ink stripe is necessary for identification purposes. The gasket is almost identical to the spacer plate to case gasket.
24. Remove 5 check balls. Note locations of check balls. (Figure 350C-39).

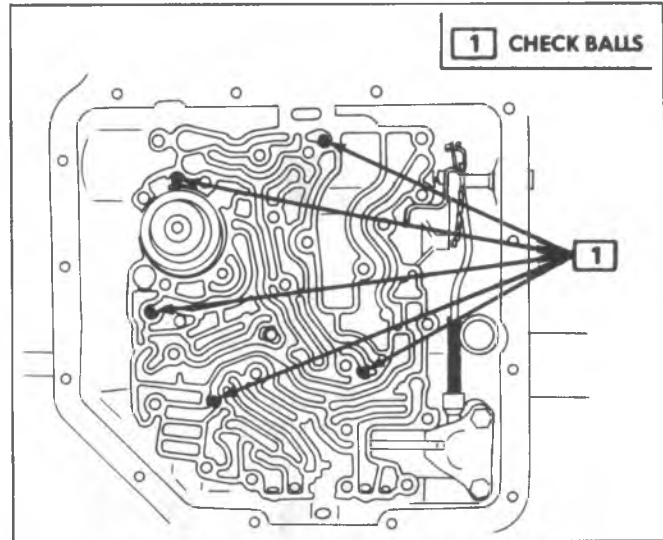

Figure 350C-39 Check Ball Locations

25. Remove park lock bracket and special bolts. Figure 350C-35A.
26. Remove oil pump pressure screen from the case. Inspect for damage, clean or replace as necessary. (Figure 350C-40).

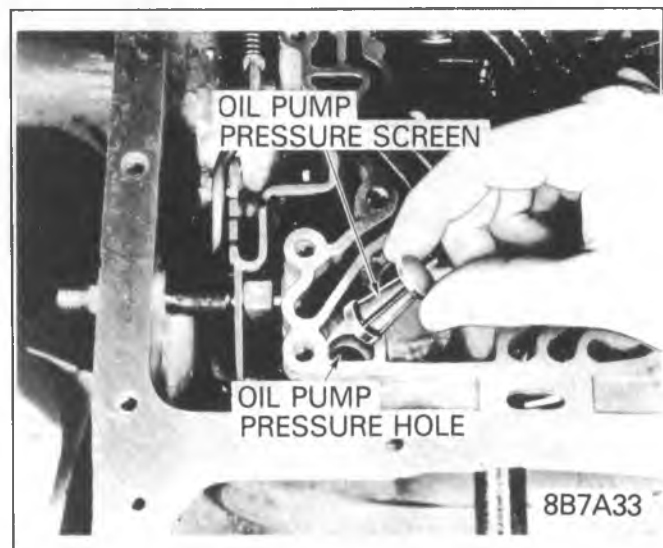

Figure 350C-40 Pump Screen Removal

27. Remove governor screen from case. Inspect for damage, clean or replace as necessary. (Figure 350C-41.)
28. Remove case electrical connector and "O" ring by depressing tabs.
29. If removal of internal manual linkage is required proceed as follows:
- a. Remove jam nut holding range selector inner lever to manual shaft.

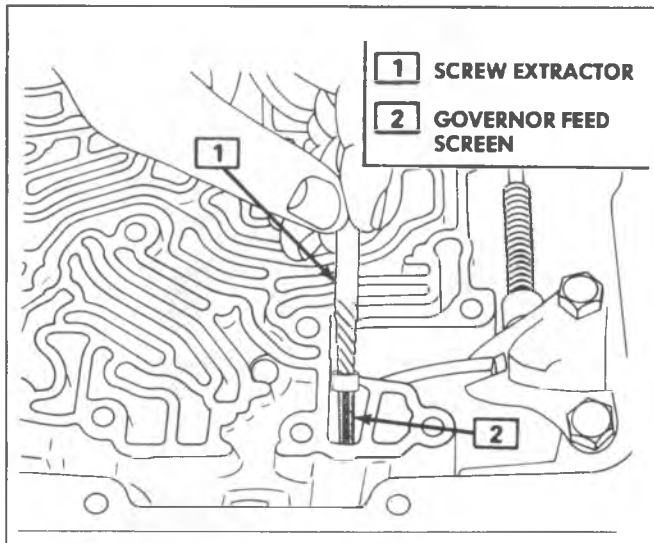

Figure 350C-41 Removing Governor Feed Screen

- b. Remove manual shaft from case. Remove range selector inner lever and parking pawl actuating rod.
- c. Remove manual shaft to case lip seal, if necessary. See Figure 350C-43.

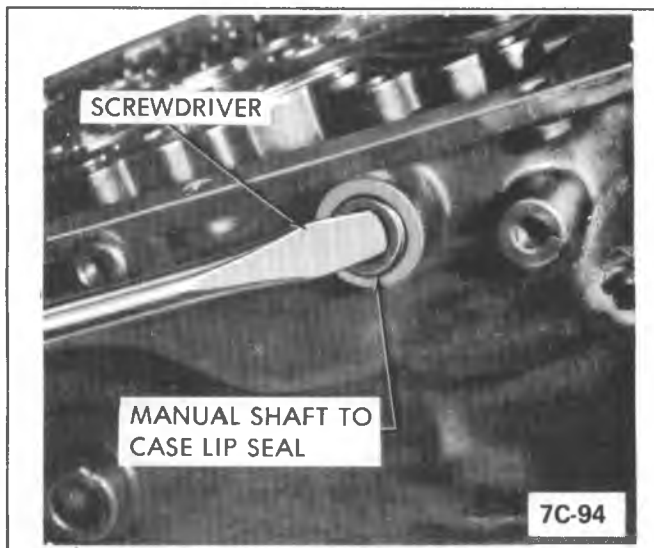

Figure 350C-43 Removing Manual Shaft Lip Seal

- d. Remove parking pawl shaft retaining plug stake marks.  
Remove retaining plug, parking pawl shaft, parking pawl, disengaging spring. See Figure 350C-45.
- 30. Remove intermediate servo piston, washer, spring seat, and apply pin. See Figure 350C-46.
- 31. If the piston or seal requires replacement, the piston assembly will have to be replaced. (Piston and Seal are one assembly).

## INTERNAL PARTS

### Removal and Inspection

#### Oil Pump Assembly

- 1. Remove eight (8) pump attaching bolts with washer type seals.



Figure 350C-45 Park Pawl

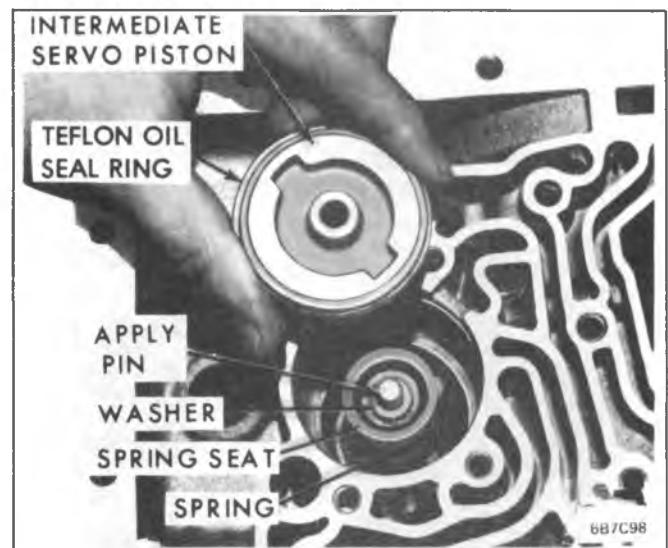

Figure 350C-46 Intermediate Servo Assembly

- 2. Install two (2) threaded slide hammers J-7004 into threaded holes in pump body. Tighten jam nuts and remove pump assembly from case. See Figure 350C-47.
- 3. Remove pump assembly to case gasket.

#### Intermediate Clutch Cushion Spring, Intermediate Clutch Plates and Intermediate Overrun Brake Band

- 1. Remove intermediate clutch cushion spring.
- 2. Remove the intermediate clutch faced plates, the steel separator plates, and one wave spring.
- 3. Inspect condition of the composition and steel plates. Do not diagnose a lined drive plate by color.
  - A. Dry composition plates with compressed air and inspect the surfaces for:
    - 1. Pitting and flaking
    - 2. Wear
    - 3. Glazing
    - 4. Cracking
    - 5. Charring
    - 6. Chips or metal particles imbedded in lining
 If the drive plate exhibits any of the above conditions, replacement is required.



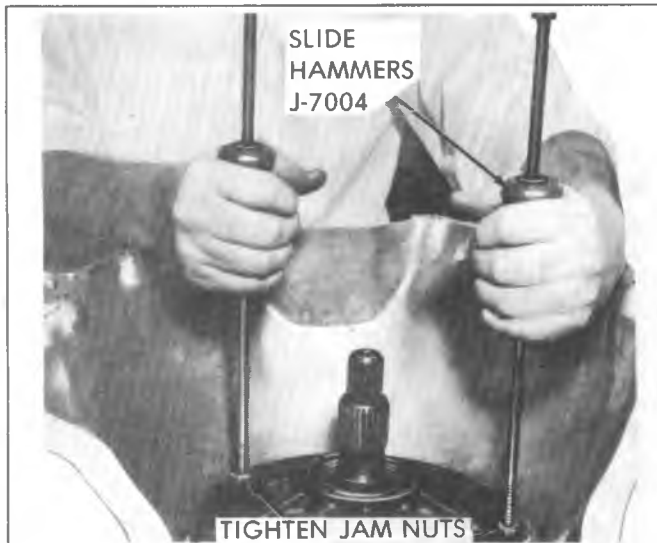

Figure 350C-47 Pump Removal

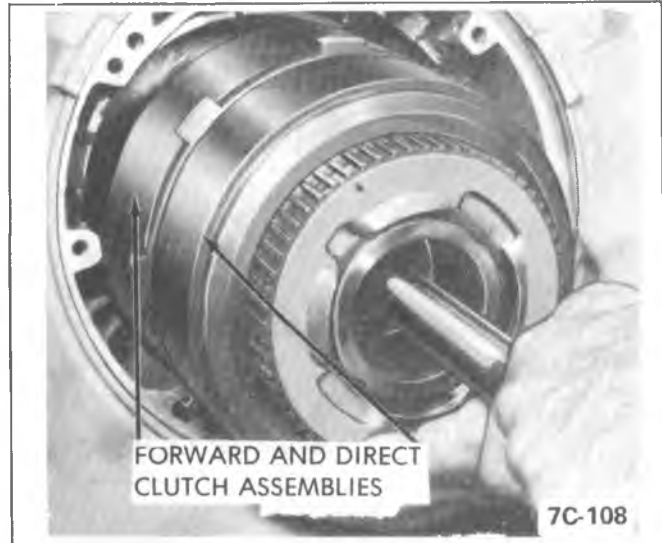

Figure 350C-50 Removing Forward and Direct Clutch Assemblies

B. Wipe steel plates dry and check for heat discoloration. If the surface is smooth and an even color smear is indicated, the plates should be reused. If severe heat spot discoloration or surface scuffing is indicated, the plates must be replaced.

4. Remove intermediate clutch pressure plate.
5. Remove intermediate overrun brake band. See Figure 350C-49.

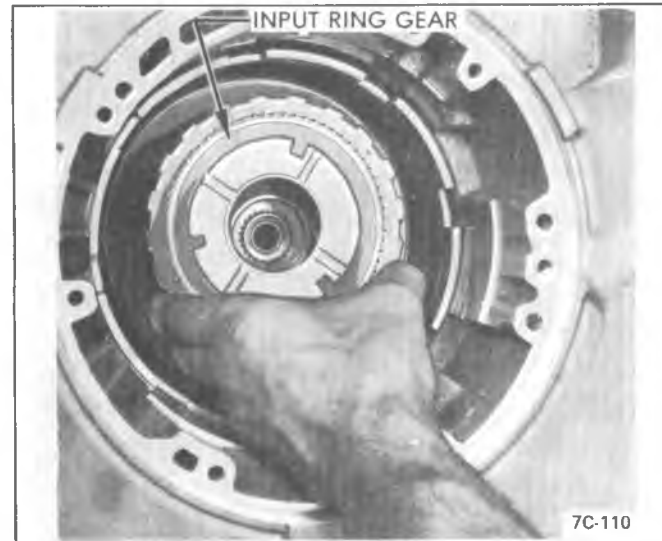

Figure 350C-51 Removing Input Ring Gear

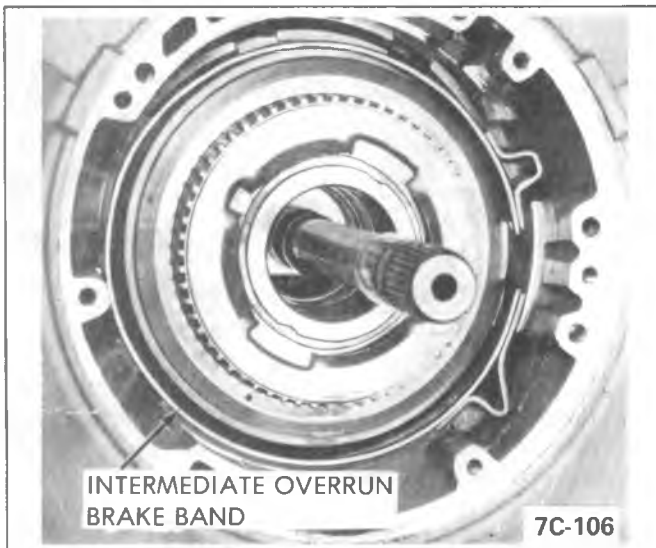

Figure 350C-49 Intermediate Overrun Brake Band

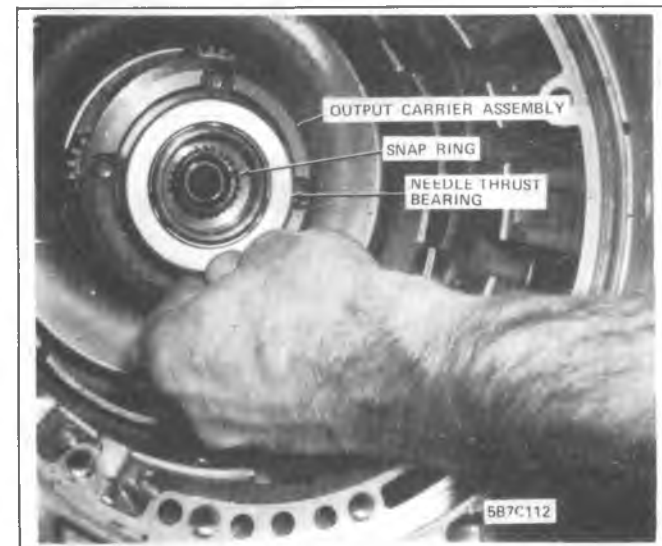

Figure 350C-52 Removing Input Carrier

### Direct and Forward Clutch Assemblies

1. Remove direct and forward clutch assemblies from case. See Figure 350C-50.

### Input Ring Gear

1. Remove forward clutch housing to input ring gear front thrust washer. Inspect for excessive wear or scoring.
2. Remove input ring gear. See Figure 350C-51.

### Output Carrier Assembly

1. Remove input ring gear to output carrier needle thrust bearing.
2. Remove output carrier to output shaft snap ring. See Figure 350C-52.

3. Remove output carrier assembly.

### Sun Gear Drive Shell Assembly

1. Remove sun gear drive shell assembly. See Figure 350C-53.

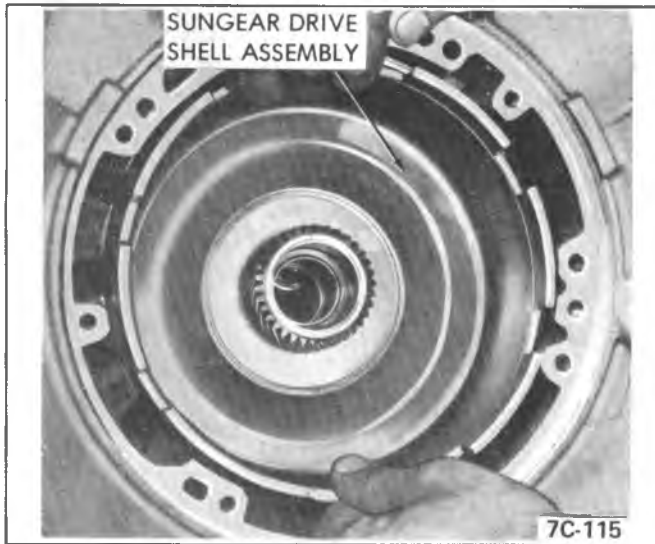

Figure 350C-53 Removing Drive Shell Assembly

### Low and Reverse Clutch Support Assembly

1. Remove low and reverse roller clutch support to case retaining ring. See Figure 350C-54.
2. Grasp the output shaft. Pull up until the low and reverse roller clutch and the support assembly, clears the low and reverse clutch support retainer spring. Remove the support assembly.
3. Remove low and reverse clutch support retainer spring. See Figure 350C-54.

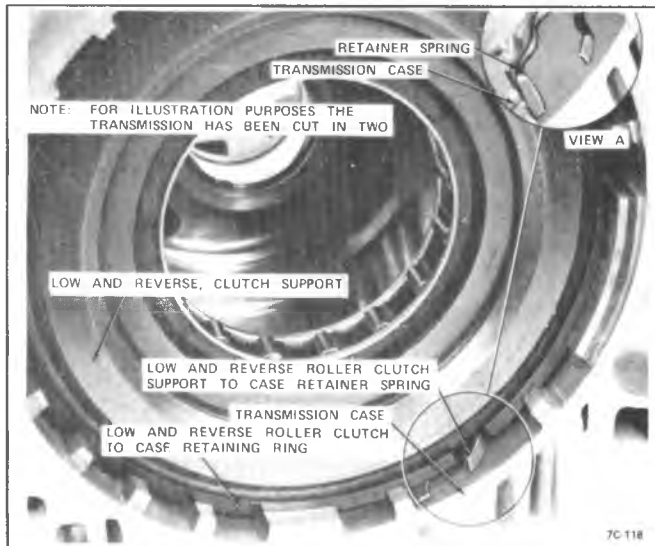

Figure 350C-54 Retainer Position

### Low and Reverse Clutch Plates

1. Remove the low and reverse clutch composition plates and the steel separator plates. See Figure 350C-55.

### Reaction Carrier Assembly

1. Remove reaction carrier assembly from output ring gear and shaft assembly. See Figure 350C-56.

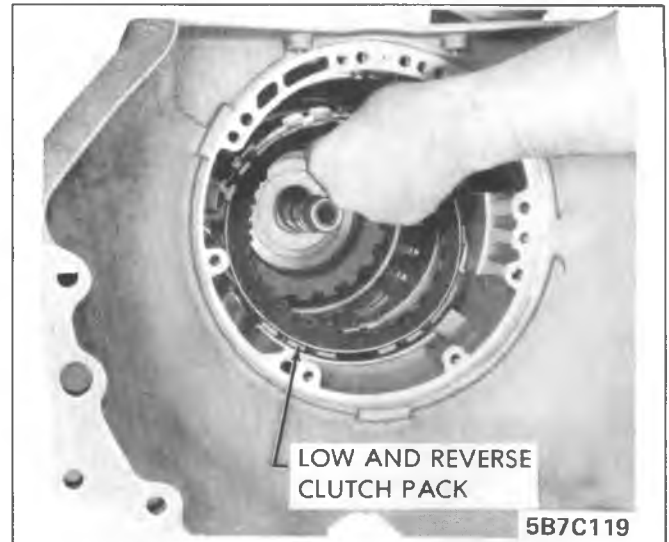

Figure 350C-55 Lo and Reverse Clutch Removal

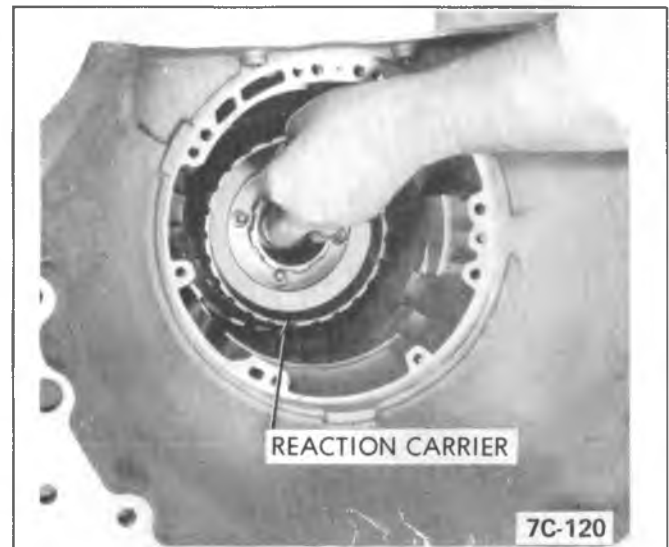

Figure 350C-56 Reaction Carrier Removal

### Output Ring Gear and Shaft Assembly

1. Remove output ring gear and shaft assembly from case. See Figure 350C-57.
2. Remove reaction carrier to output ring gear needle thrust bearing.
3. Remove output ring gear to output shaft snap ring. Remove output ring gear from output shaft.
4. Remove output ring gear to case needle bearing. See Figure 350C-59.

### Low and Reverse Clutch Piston

1. Using Tool J-23327 compress low and reverse clutch piston spring retainer and remove piston retaining ring, and spring retainer with springs. See Figure 350C-60.
2. Remove low and reverse clutch piston assembly. Aid removal with the use of compressed air in passage shown. See Figure 350C-61.

### Low and Reverse Clutch Piston Seals

1. Remove low and reverse clutch piston outer seal.
2. Remove low and reverse clutch piston center and inner seal. See Figure 350C-62.

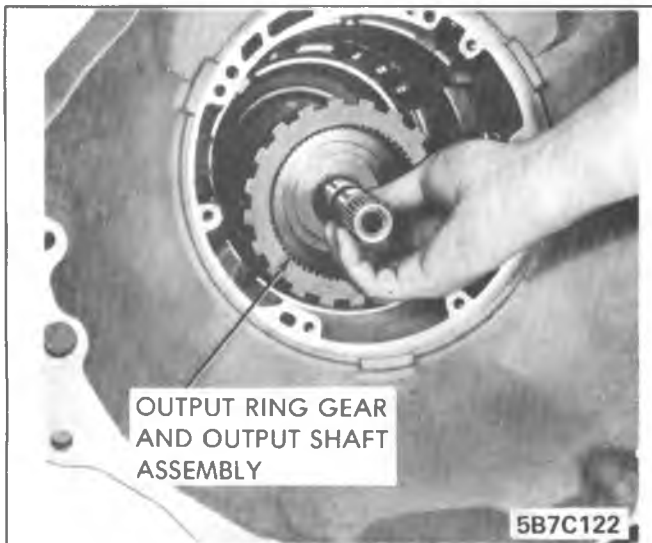

Figure 350C-57 Output Ring Gear and Shaft Assembly Removal

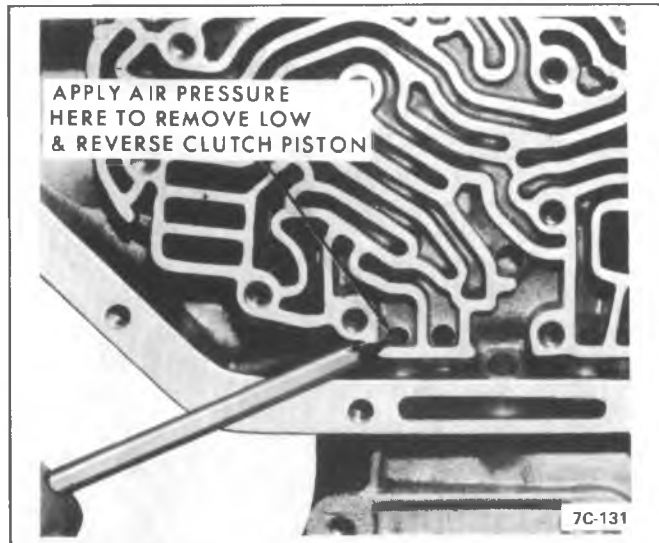

Figure 350C-61 Location for Air Pressure

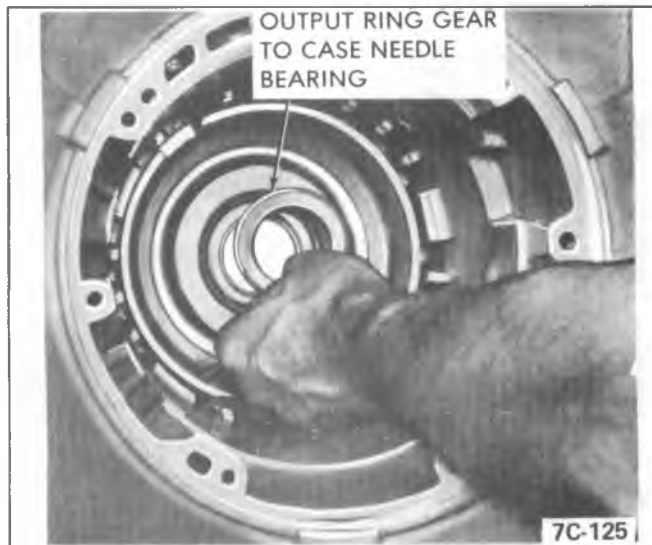

Figure 350C-59 Removal of Needle Bearing

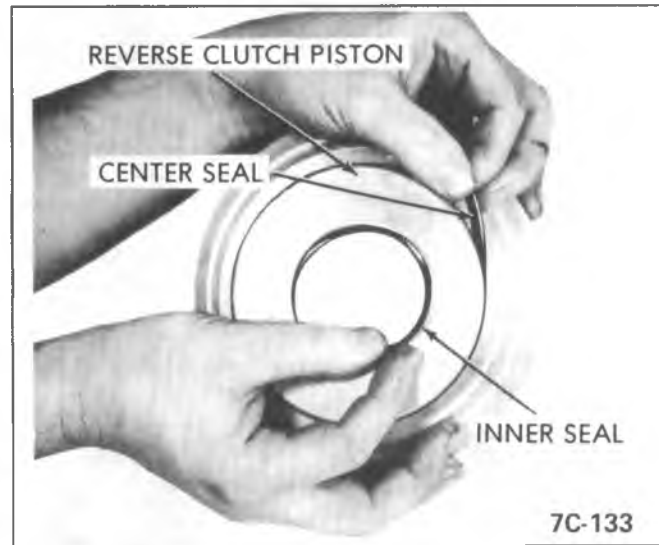

Figure 350C-62 Piston Seal Removal

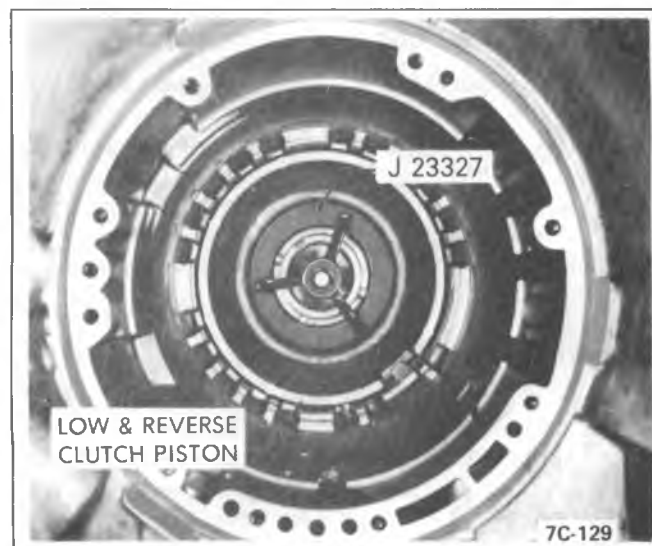

Figure 350C-60 Remove Low and Reverse Piston Snap Ring

### Intermediate Clutch 1-2 Accumulator Piston

Removal and installation of intermediate clutch 1 - 2 accumulator can be done without removal of transmission from car. See On Car Service.

1. Install Tool J-23069 to compress intermediate clutch 1-2 accumulator cover and remove retaining ring. See Figure 350C-63.
2. Remove intermediate clutch 1-2 accumulator piston cover and "O" ring seal from case. See Figure 350C-64.
3. Remove intermediate clutch 1-2 accumulator piston spring. See Figure 350C-64.
4. Remove intermediate clutch 1-2 accumulator piston assembly. *Inspect the inner and outer teflon oil seal rings for wearing or scoring. DO NOT REMOVE THESE TWO RINGS UNLESS THEY ARE DAMAGED.* If replacement of one or the other of the two rings is necessary, the piston assembly will have to be replaced. See Figure 350C-64. (Piston and Seal are one assembly).

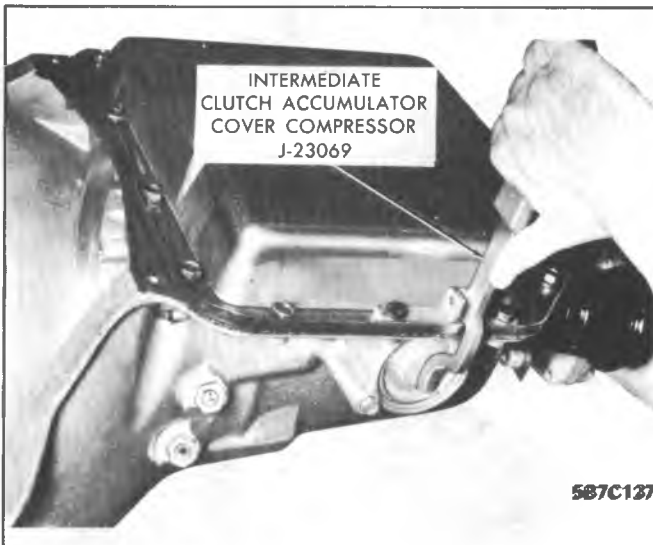

Figure 350C-63 Removal of 1-2 Accumulator Cover

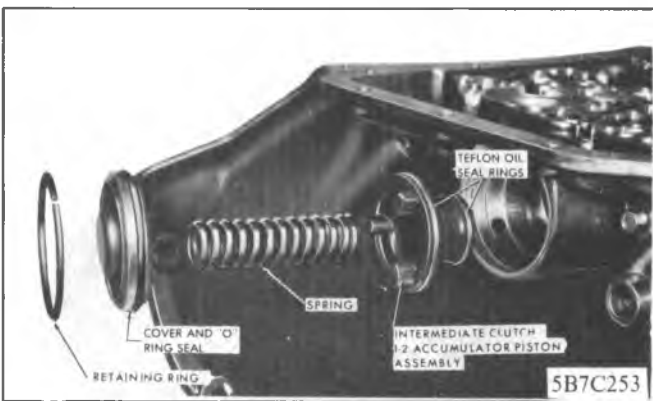

Figure 350C-64 Intermediate Clutch 1-2 Accumulator

### Intermediate Clutch 1-2 Accumulator Piston

#### Installation

1. Install intermediate clutch 1-2 accumulator piston assembly and spring. See Figure 350C-64.
2. Place new "O" ring seal on intermediate clutch 1-2 accumulator piston cover, and install cover into case. See Figure 350C-64.
3. Install J-23069 tool and compress intermediate clutch 1-2 accumulator cover and install retaining ring. See Figure 350C-63.

### INTERNAL PARTS

#### Disassembly, Inspection and Reassembly

#### Oil Pump

##### Disassembly

1. Place stator shaft side of pump assembly through hole in bench. Remove five (5) pump cover to body attaching bolts. See Figure 350C-65.
2. Remove intermediate clutch return spring seat retainer, springs and the intermediate clutch piston assembly. See Figure 350C-66.
3. Remove intermediate clutch piston inner and outer seals. See Figure 350C-66.
4. Remove three (3) direct clutch to pump hub oil rings. Remove pump cover to direct clutch drum needle thrust bearing. Inspect the two (2) forward clutch to

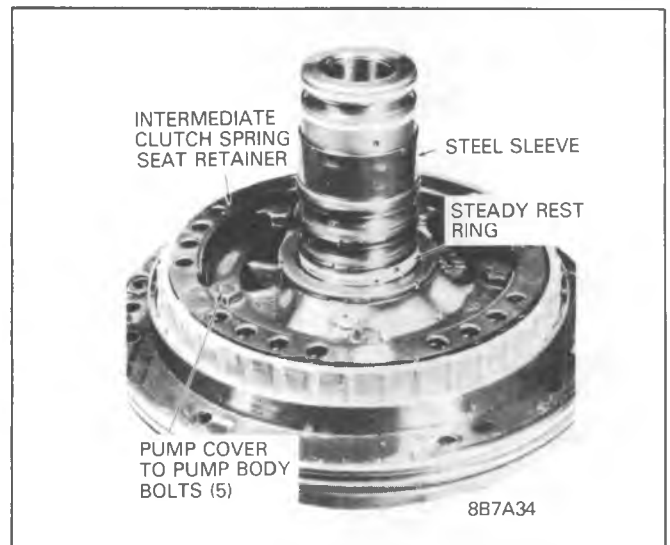

Figure 350C-65 Intermediate Clutch Piston Removal

pump hub teflon oil seal rings, (some rings will be solid, new type rings will be scarf cut for easier assembly with no expander ring behind) but do not remove them unless they are damaged. If replacement is necessary, use two metal hook type service replacement rings. See Figure 350C-66.

5. Check steady rest ring, if cut or frozen in bore remove and replace with the same color ring.  
The different colors compensate for groove depth.
6. Remove pump cover and stator shaft assembly from pump body. See Figure 350C-68.
7. Remove pump drive gear and driven gear from pump body. Inspect pump gears and cover for wear or scoring. See Figure 350C-69.  
The pump body assembly should be replaced only if:
  - a. The drive and/or driven gears are broken or galled.
  - b. Pump body galled.
  - c. Uneven machined surfaces
  - d. Pump body to case seal ring groove damaged.
  - e. Pump seal drainback hole is unmachined.
8. Remove pump outside diameter to case square cut "O" ring seal. See Figure 350C-66.
9. Remove pump body to converter hub lip seal, if necessary. See Figure 350C-72.
10. Place pump on wood blocks so surface finish is not damaged and install pump to converter hub lip seal using Seal Driver J-21359. See Figure 350C-73.  
Make certain lip seal is not turned or nicked.

##### Inspection and Reassembly

1. Install pump drive gear and driven gear. Assemble drive gear with tang face up to prevent damage to converter. See Figure 350C-69.
3. Assemble pump cover to pump body. See Figure 350C-68.
4. Install intermediate clutch piston new inner and outer seals. See Figure 350C-67.
5. Install intermediate clutch piston assembly into pump cover with J-26744-A.
6. Install spring retainer and install five (5) attaching bolts, finger tight. See Figures 350C-66 and 350C-65.
7. Place pump aligning strap, J-21368 over pump body and cover and tighten.
8. Torque attaching bolts to 18 ft. lbs. (24 N·m).

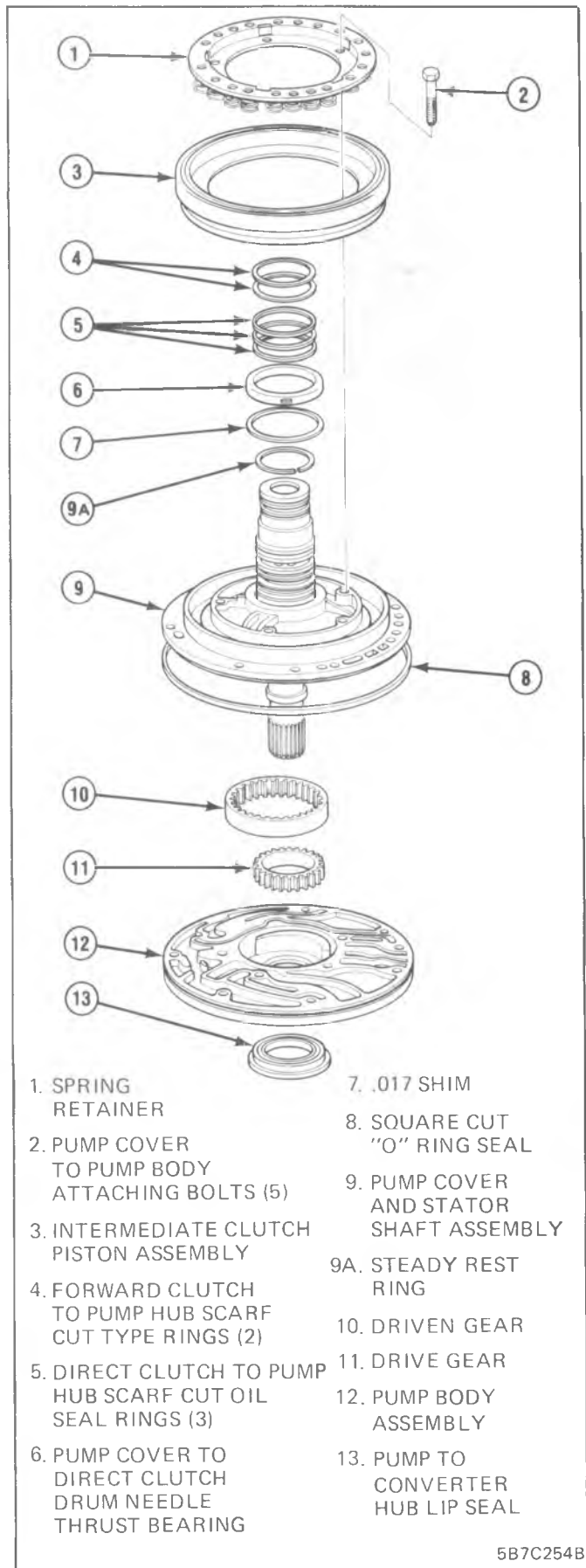

Figure 350C-66 Oil Pump Assembly

9. Install pump outside diameter to case square cut seal. See Figure 350C-66. Use new seal, if necessary.

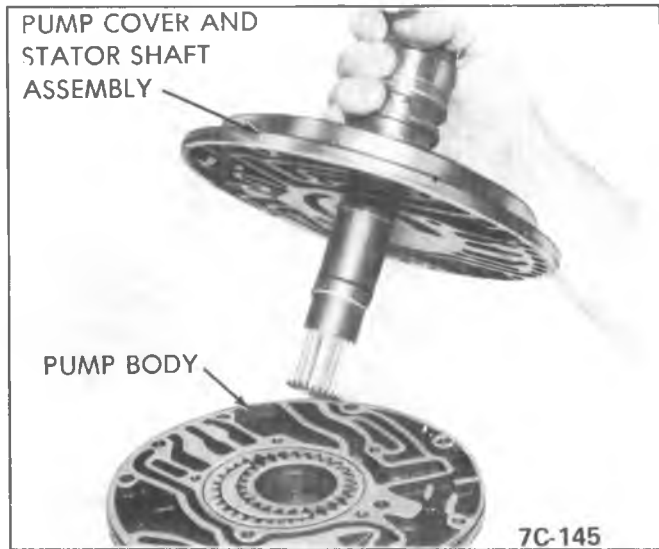

Figure 350C-68 Pump Cover Removal

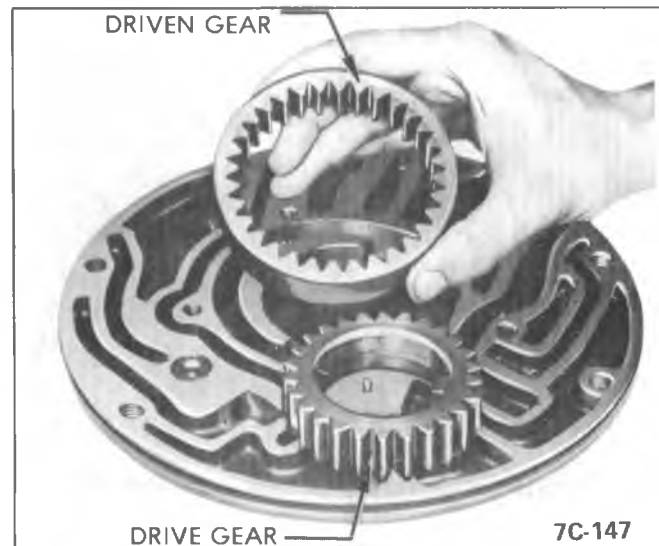

Figure 350C-69 Oil Pump Gears

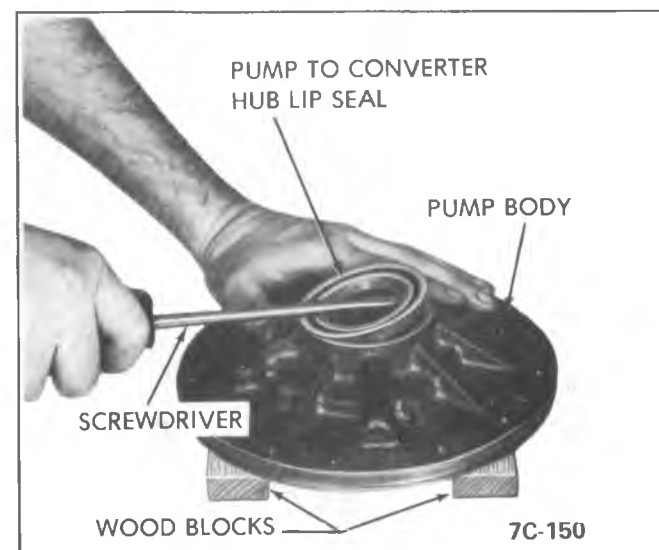

Figure 350C-72 Converter Seal Removal

10. Install three (3) direct clutch to pump hub scarf cut oil seal rings. Inspect two (2) forward clutch to pump hub



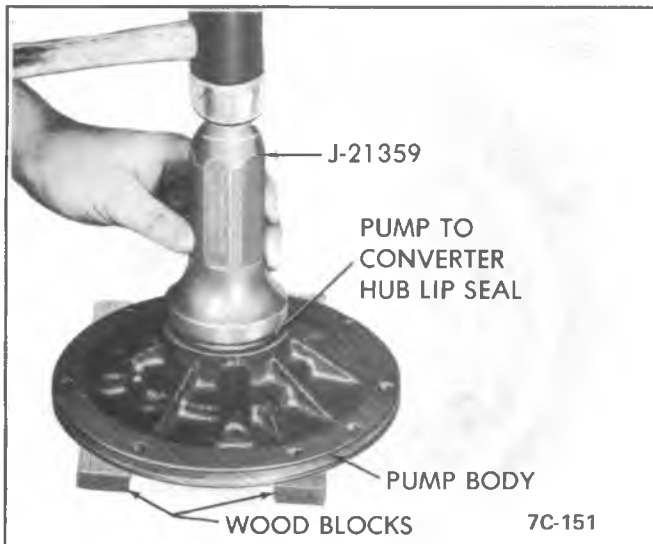

Figure 350C-73 Converter Seal Installation

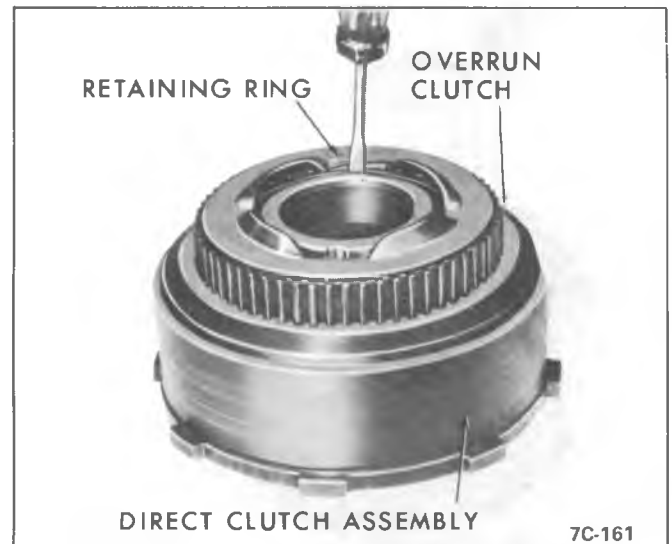

Figure 350C-76 Overrun Clutch Retaining Ring

oil seal rings, (some rings will be solid, new type rings will be scarf cut for easier assembly with no expander ring behind) for service if rings require replacement use hook type cast iron rings. See Figure 350

11. Check three (3) pump cover hub lube holes. Make certain they are not restricted. See Figure 350C-75.



Figure 350C-75 Lube Hole Location



Figure 350C-77 Roller Clutch Outer Race

## DIRECT CLUTCH

### Disassembly

Refer to specifications in rear of this section to determine the required amount of composition and steel clutch plates to use with specific transmission model and engine combination. When replacing piston assembly specific part number must be used.

1. Remove intermediate overrun clutch front retainer ring and retainer. See Figure 350C-76.
2. Remove intermediate clutch overrun outer race. See Figure 350C-77.
3. Remove intermediate overrun roller clutch assembly. See Figure 350C-77.
4. Remove direct clutch drum to forward clutch housing needle roller bearing. See Figure 350C-79.
5. Remove direct clutch pressure plate to clutch drum retaining ring and pressure plate. See Figure 350C-80.

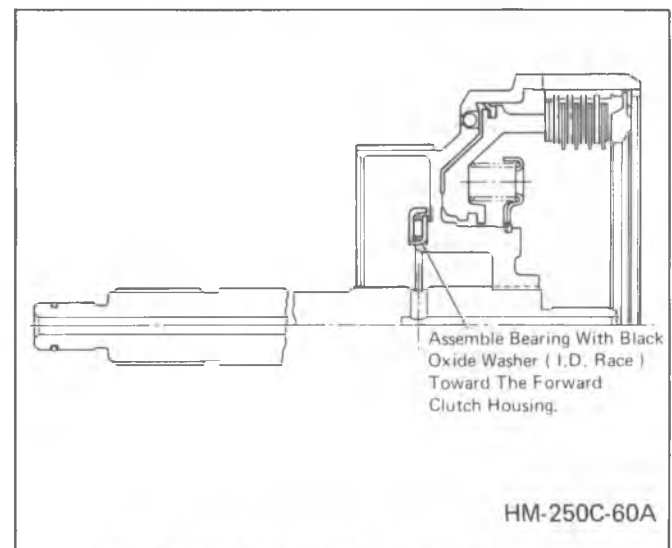

Figure 350C-79 Needle Bearing Assembly

6. Remove composition plates, steel plates and one cushion spring from direct clutch housing.

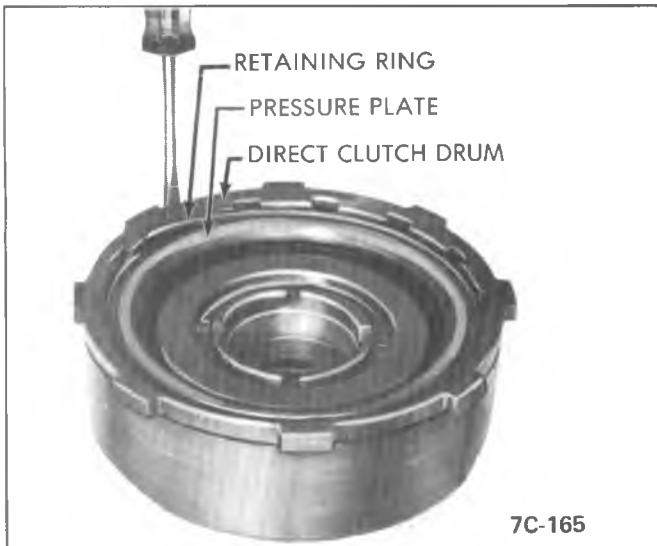

Figure 350C-80 Disassembly of Direct Clutch

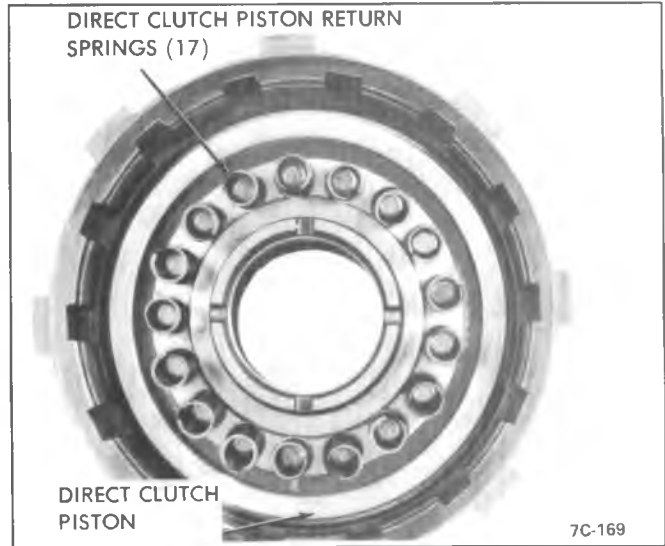

Figure 350C-83 Install Piston Return Springs

7. Inspect condition of lined and steel plates. *Do not diagnose a composition drive plate by color.*
8. Remove direct clutch piston return spring seat retaining ring and spring seat by using Tools J- 2590-3, J-2590-5, and snap ring pliers. See Figure 350C-82.

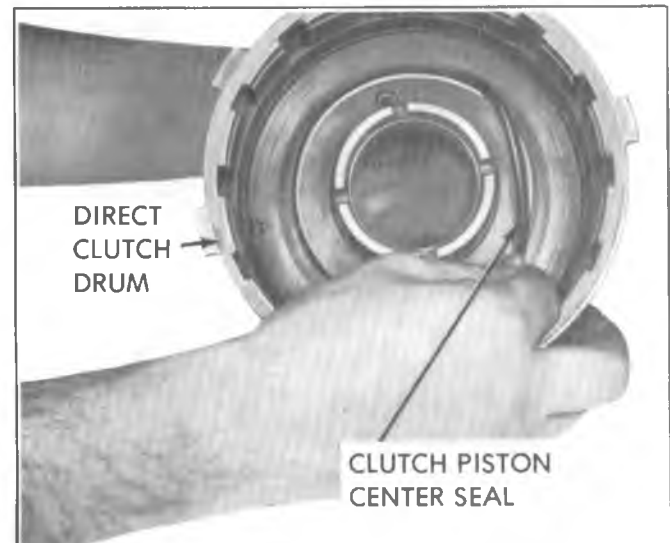

Figure 350C-85 Install Center Seal

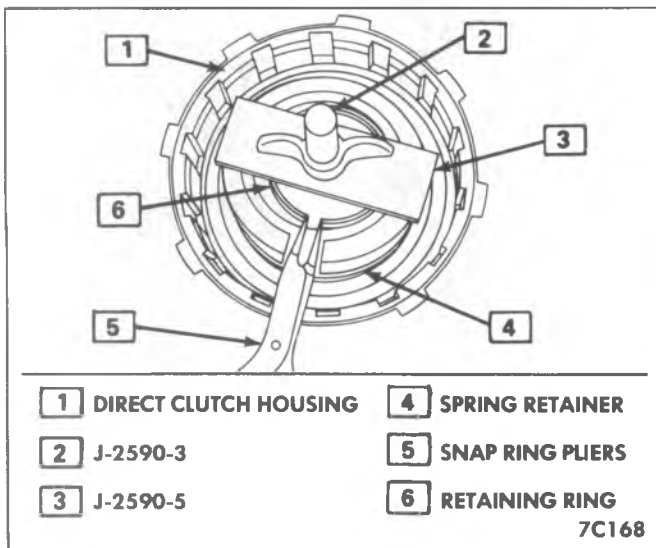

Figure 350C-82 Piston Snap Ring Removal

9. Remove spring retainer, springs and piston. See Figure 350C-83.
10. Inspect the return springs. Evidence of extreme heat or burning in the area of the clutch may have caused the springs to take a heat set and would justify replacement of the springs.
11. Remove direct clutch piston inner and outer seals.
12. Remove direct clutch piston center seal. See Figure 350C-85.

**Reassembly**

1. Install new direct clutch piston outer seal and inner seal.
2. Install new direct clutch piston center seal. See Figure 350C-85.
3. Install the direct clutch piston into housing with the aid of a piece of .020" music wire crimped into copper tubing. Use a liberal amount of transmission fluid during assembly. See Figure 350C-86.



Figure 350C-86 Install Piston

4. Install spring retainer and springs. Compress spring retainer and install retaining ring, using Tools J-2590-3 and J-2590-5. See Figure 350C-82.

5. Lubricate with transmission fluid and install composition plates and steel plates starting with a steel plate and alternating steel and composition.
6. Install direct clutch pressure plate and retaining ring. See Figure 350C-80.
7. Install intermediate overrun roller clutch assembly. See Figure 350C-89. Roller clutch assembly must be assembled with four (4) holes up (toward front of transmission).
8. Install intermediate clutch overrun outer race. See Figure 350C-89.  
When the intermediate overrun clutch outer race is installed, it should free wheel in the counterclockwise direction only.
9. Install intermediate overrun clutch retainer, and retaining ring. See Figure 350C-89.

## Forward Clutch

### Disassembly and Inspection

Refer to specifications in rear of this section to determine the required amount of composition and steel clutch plates to use with specific transmission model and engine combination. When replacing piston assembly specific part number must be used.

1. Remove forward clutch drum to pressure plate retaining ring. Remove forward clutch pressure plate. See Figure 350C-90.
2. Remove forward clutch housing faced plates, steel plates, and cushion spring.
3. Inspect condition of lined and steel plates. *Do not diagnose a drive plate by color.*
4. Remove spring retainer and springs by compressing with a ram press. See Figure 350C-92.
5. Inspect the return springs. Evidence of extreme heat or burning in the area of the clutch may have caused the springs to take a heat set and would justify replacement of the springs.
6. Remove forward clutch piston assembly.
7. Inspect the forward clutch piston inner and outer seals, for nicks or tears. Remove and replace if necessary. See Figure 350C-93.
8. Make certain forward clutch ball check exhaust is free of dirt, etc. See Figure 350C-96.
9. If the input shaft is scored excessively it may be replaced using the following procedure.
  - a. Using wood blocks for support press input shaft out of forward clutch housing.
  - b. Carefully support forward clutch housing on rear thrust washer surface and press input shaft into housing until it is properly seated.

**When pressing the input shaft into the forward clutch housing, care must be taken not to place excessive force on the pilot end of the input shaft as damage may result.**

### Reassembly

1. Install the forward clutch inner piston seal and outer piston seal, if previously removed.
2. Install the forward clutch piston assembly using a thin feeler gage. See Figure 350C-99.
3. Install spring retainer and springs. Compress spring retainer with an arbor press or ram press. See Figure 350C-92.
4. Lubricate with transmission fluid and install cushion spring, faced plates and steel separator plates, starting

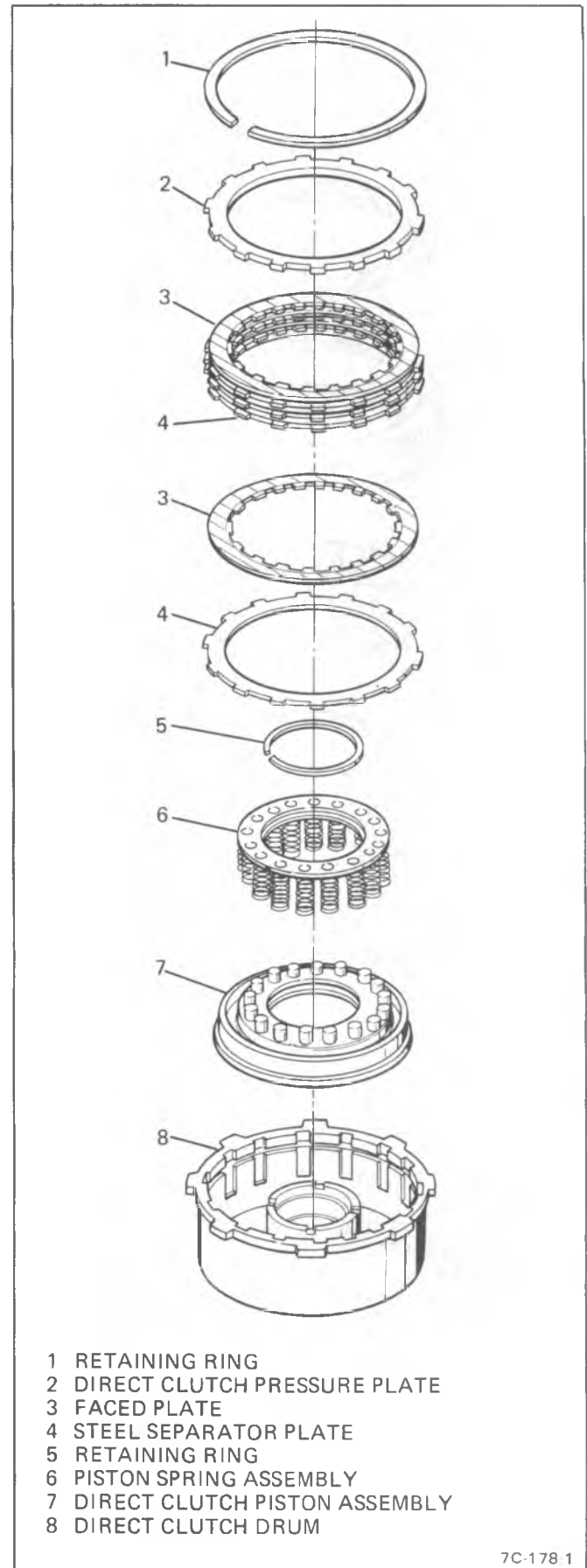

7C-178 1

Figure 350C-88 Direct Clutch Assembly

with the cushion spring and alternating steel and faced. See Figure 350C-93.



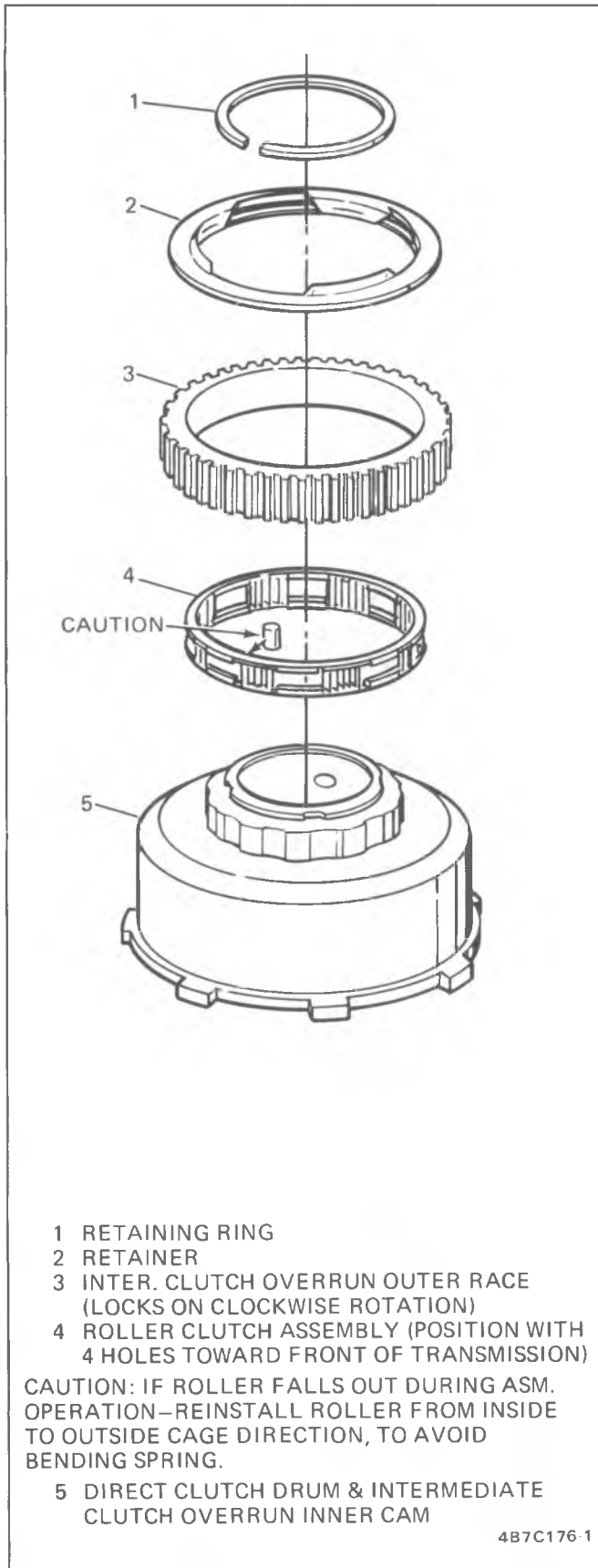

Figure 350C-89 Intermediate Overrun Roller Clutch Assembly

5. Install forward clutch pressure plate and retaining ring. Using a feeler gage check clearance between forward clutch pressure plate and faced plate. See Figure 350C-100.

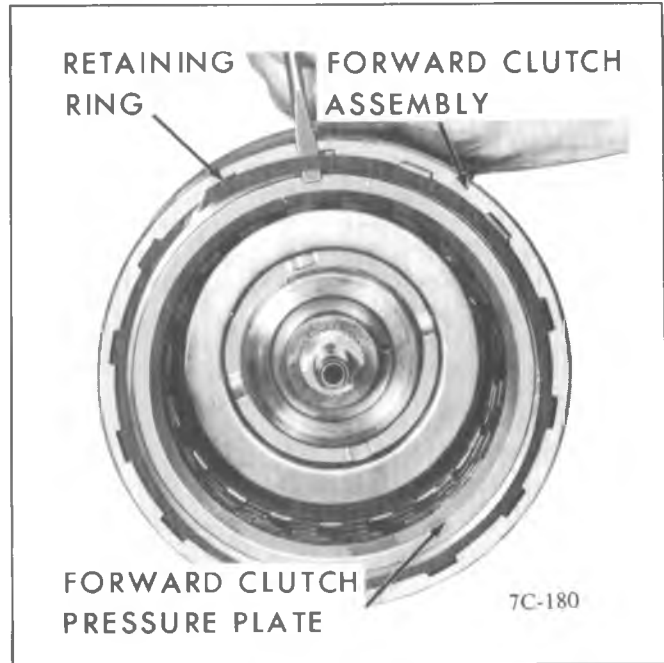

Figure 350C-90 Forward Clutch Retaining Ring

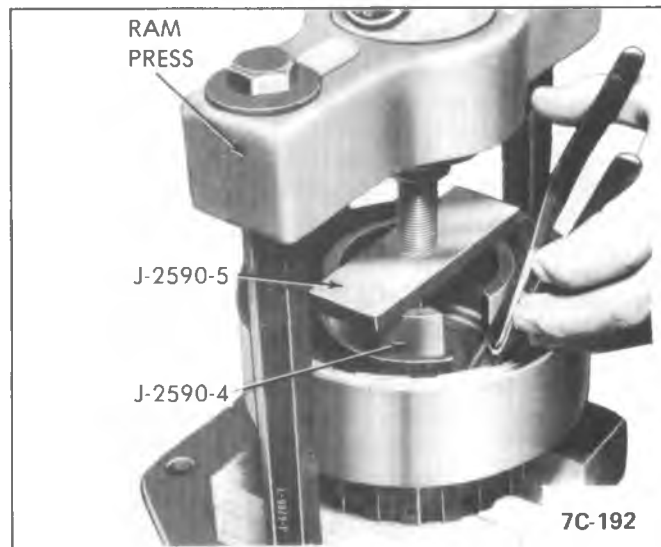

Figure 350C-92 Forward Clutch Piston Snap Ring Removal

The specifications for this transmission call for a clearance of no less than .011" and no greater than .082". There are three pressure plates available which are identified by tangs adjacent to the source identification mark. See Figure 350C-101. These three pressure plates have different thicknesses.

If the clearance between the forward clutch pressure plate and the faced plate checks out to be less than .011", a thinner pressure plate should be used to have a clearance between .011" and .082". If the clearance checks out to be greater than .082", a thicker pressure plate should be used to have a clearance between .011" and .082". If the clearance checks out to be between .011" and .082", no change of pressure plate is necessary.

### Sun Gear to Drive Shell

#### Disassembly

1. Remove sun gear to sun gear drive shell rear retaining ring. See Figure 350C-102.

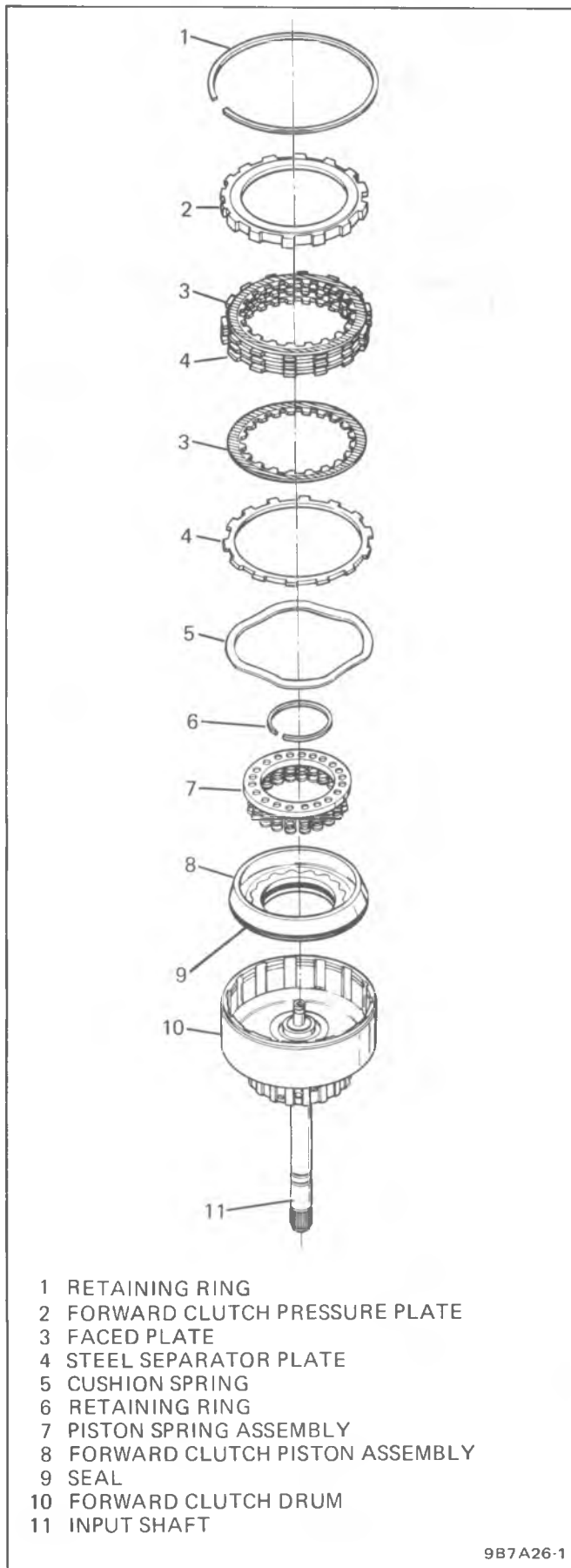

Figure 350C-93 Forward Clutch Assembly

2. Remove sun gear to drive shell flat rear thrust washer. See Figure 350C-102.

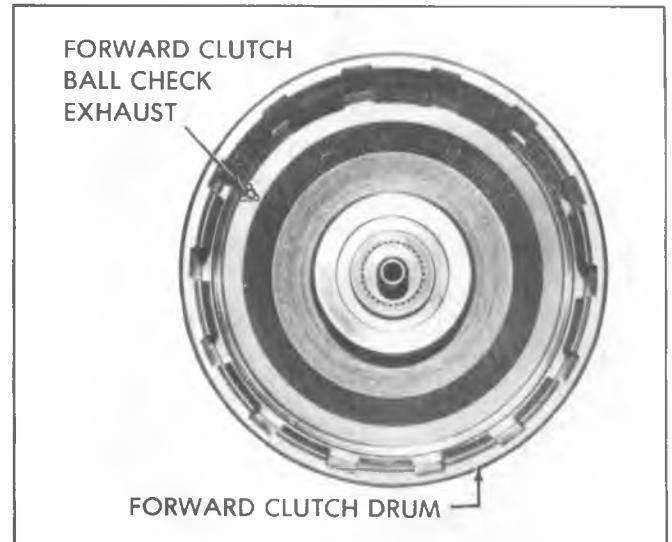

Figure 350C-96 Ball Exhaust Location

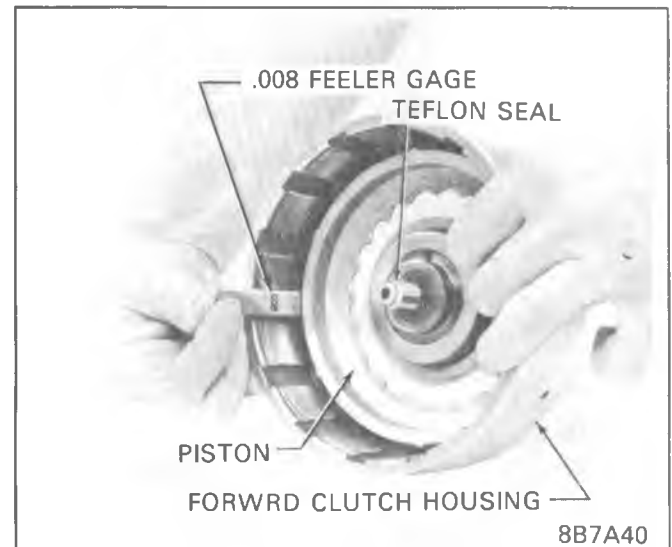

Figure 350C-99 Installing Clutch Piston

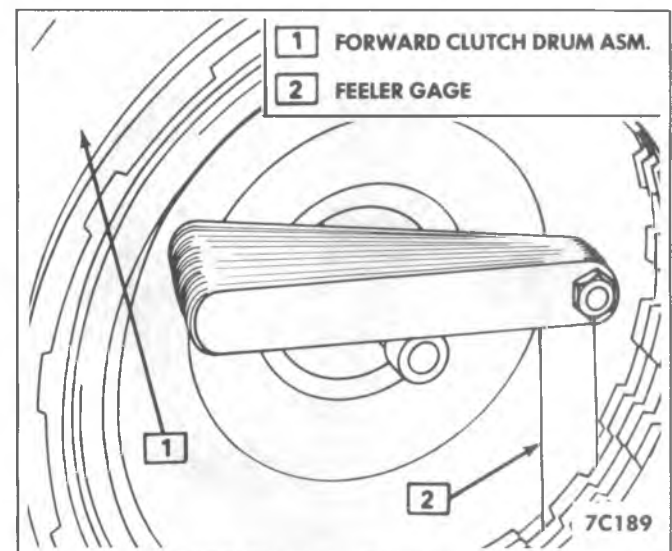

Figure 350C-100 Checking Pressure Plate Clearance

3. Remove front retaining ring from sun gear. See Figure 350C-104.

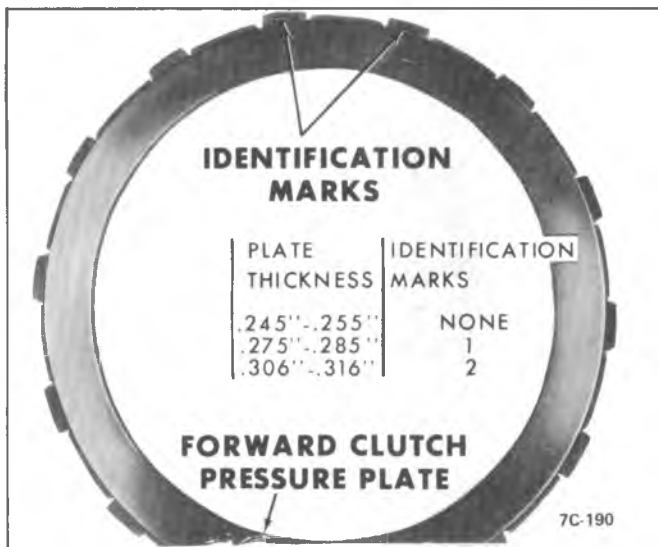

Figure 350C-101 Pressure Plate Selection

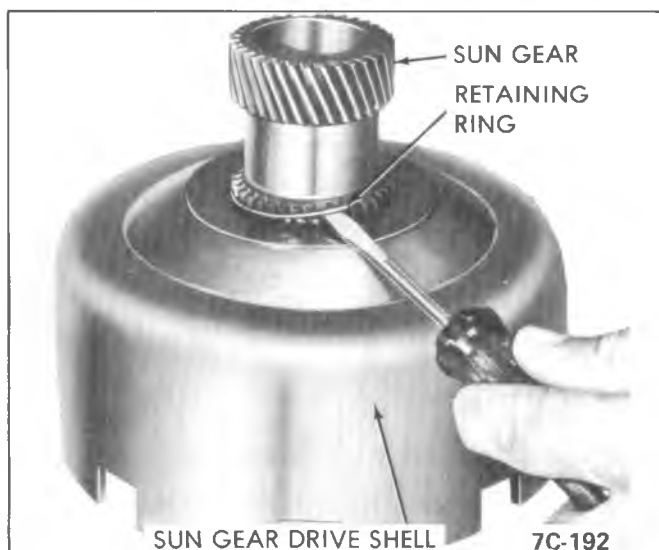

Figure 350C-102 Sun Gear Retaining Ring Removal

4. Inspect parts for wear or damage. Replace parts if necessary.

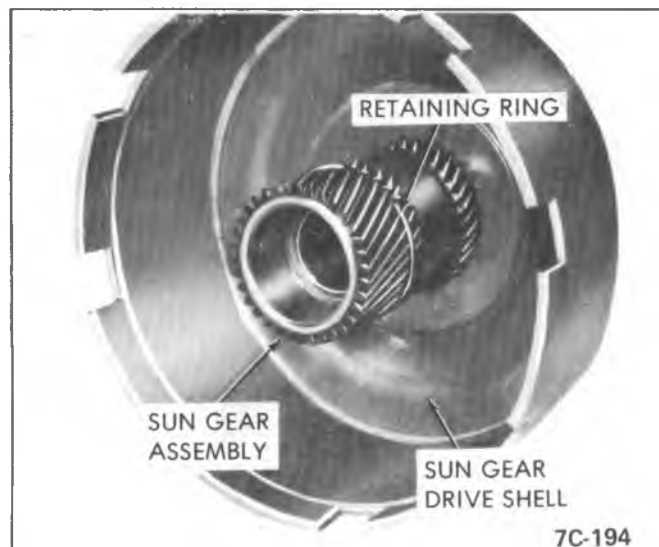

Figure 350C-104 Front Retaining Ring Removal

### Reassembly

1. Install sun gear to drive shell front retaining ring, and install into drive shell. See Figure 350C-104. Use a new ring and do not overstress when installing.
2. Install sun gear to drive shell flat thrust washer. See Figure .
3. Install sun gear to sun gear drive shell rear retaining ring. See Figure 350C-102. Use a new ring and do not overstress when installing.

### Low and Reverse Roller Clutch (Refer to Figure 350C-105)

#### Disassembly

1. Remove low and reverse clutch to sun gear shell thrust washer.
2. Remove low and reverse overrun clutch inner race.
3. Remove low and reverse roller clutch retaining ring.
4. Remove low and reverse roller clutch assembly and visually inspect the rollers for wearing and scoring and check for any springs that may be collapsed.

#### Reassembly

1. Install low and reverse roller clutch assembly to inner race. See Figure 350C-106. The inner race should free wheel in the clockwise direction only.
2. Install low and reverse overrun roller clutch assembly and inner race into the low and reverse clutch support. See Figure 350C-107. Assemble with four (4) holes down or to rear of transmission.
3. Install low and reverse clutch to cam retaining ring. See Figure 350C-108.
4. Install low and reverse clutch to sun gear drive shell thrust washer. See Figure 350C-105.

### Valve Body (Refer to Figure 350C-110)

#### Disassembly

1. Position valve body assembly with cored face up.
2. Remove manual valve from lower left hand bore (J).
3. From lower right hand bore (A) remove the pressure regulator valve train retaining pin, boost valve sleeve, intermediate boost valve, reverse and modulator boost valve, pressure regulator valve spring, and the pressure regulator valve.
4. From the next bore (B), remove the 2-3 shift valve train retaining pin, sleeve, control valve spring, 2-3 shift control valve, shift valve spring, and the 2-3 shift valve.
5. From the next bore (C), remove the 1-2 shift valve train retaining pin, sleeve, shift control valve spring, 1-2 shift control valve, and the 1-2 shift valve.
6. From the next bore (E), remove retaining pin, plug, manual low control valve spring, and the manual low control valve.
7. From the next bore (F), remove the retaining pin, spring, seat, and the detent regulator valve.
8. Install Tool J-22269, on direct clutch 2-3 accumulator piston and remove retaining "E" ring. (G) See Figure 350C-111.
9. Remove direct clutch 2-3 accumulator piston, and spring. (G) If the piston seal needs replacing the piston assembly will have to be replaced. (Piston and Seal are one assembly).
10. From the next bore down (D) from the direct clutch accumulator, remove the detent actuating lever bracket bolt, bracket, actuating lever and retaining pin, stop, spring retainer, seat, outer spring, inner spring, washer

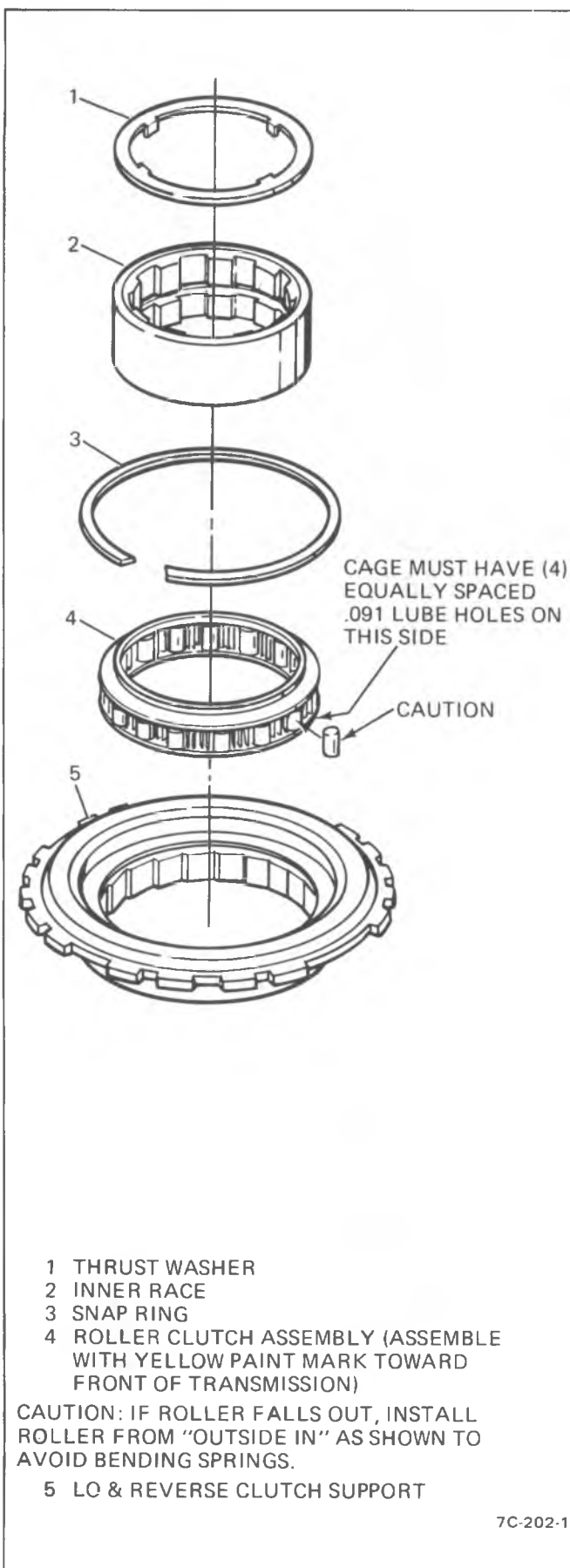

Figure 350C-105 Low and Reverse Clutch Support and Overrun Roller Clutch Assembly and the detent valve. Use care when handling valve

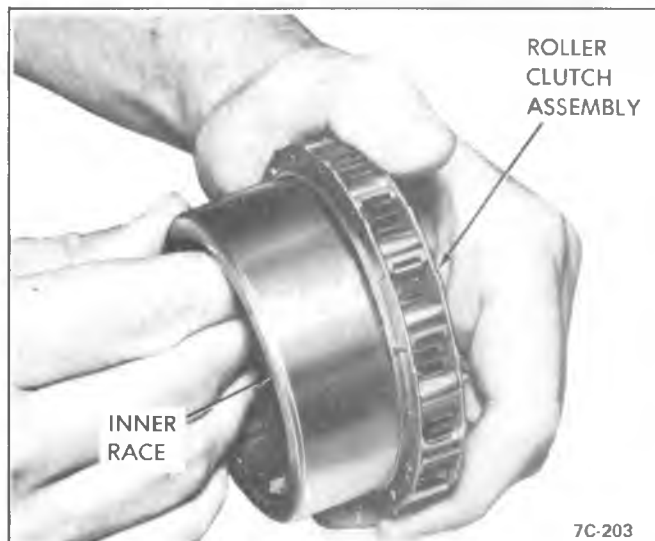

Figure 350C-106 Checking Roller Clutch

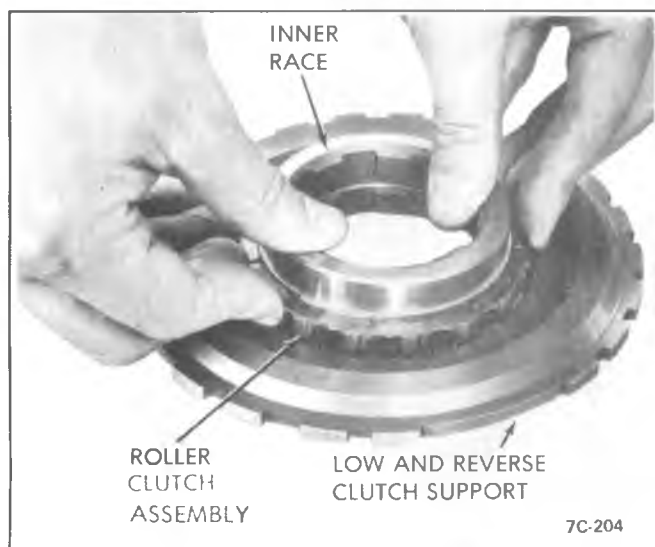
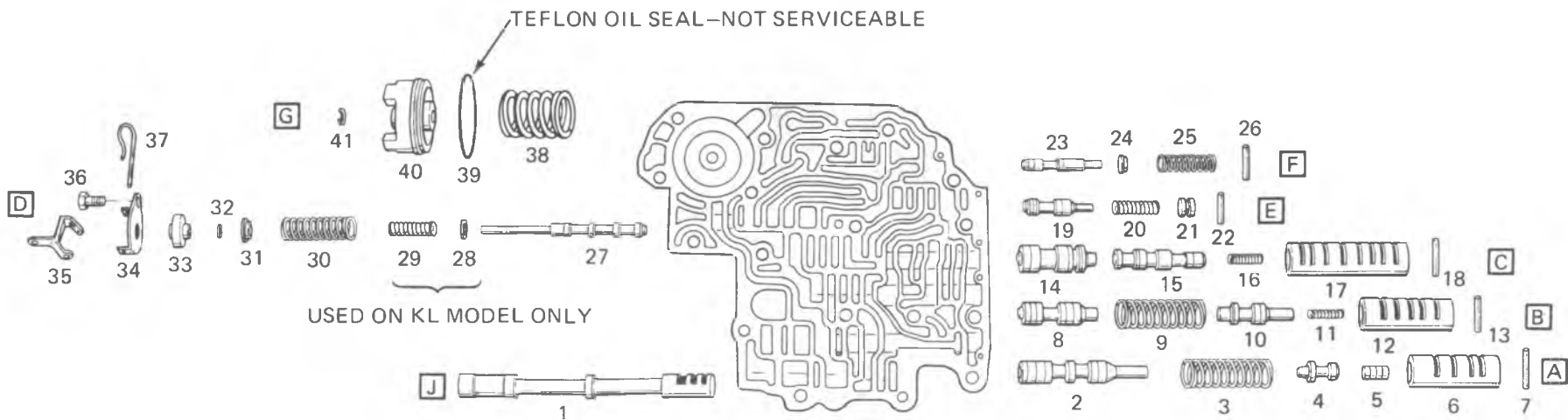

Figure 350C-107 Install Roller Clutch Inner Race



Figure 350C-108 Install Roller Clutch Retaining Ring

body assembly as valve body sleeve retaining pins may fall out.



- J — 1 MANUAL VALVE AND LINK ASSEMBLY
- A {
  - 2 PRESSURE REGULATOR VALVE
  - 3 PRESSURE REGULATOR VALVE SPRING
  - 4 REVERSE & MODULATOR BOOST VALVE
  - 5 INTERMEDIATE BOOST VALVE
  - 6 BOOST VALVE SLEEVE
  - 7 RETAINING PIN
- B {
  - 8 2-3 SHIFT VALVE
  - 9 2-3 SHIFT VALVE SPRING
  - 10 2-3 SHIFT CONTROL VALVE
  - 11 2-3 SHIFT CONTROL VALVE SPRING
  - 12 2-3 SHIFT CONTROL VALVE SLEEVE
  - 13 RETAINING PIN
- C {
  - 14 1-2 SHIFT VALVE
  - 15 1-2 SHIFT CONTROL VALVE
  - 16 1-2 SHIFT CONTROL VALVE SPRING
  - 17 1-2 SHIFT CONTROL VALVE SLEEVE
  - 18 RETAINING PIN
- E {
  - 19 MANUAL LOW CONTROL VALVE
  - 20 MANUAL LOW CONTROL VALVE SPRING
  - 21 PLUG
  - 22 RETAINING PIN

- F {
  - 23 DETENT REGULATOR VALVE
  - 24 DET. REGULATOR VALVE SPRING SEAT
  - 25 DETENT REGULATOR VALVE SPRING
  - 26 RETAINING PIN
  - 27 DETENT VALVE
  - 28 WASHER
  - 29 DETENT VALVE INNER SPRING
  - 30 DETENT VALVE OUTER SPRING
- D {
  - 31 DETENT VALVE OUTER SPRING SEAT
  - 32 DETENT VALVE SPRING RETAINER
  - 33 DETENT VALVE STOP
  - 34 DET. VALVE ACTUATING LEVER BRKT.
  - 35 DETENT VALVE ACTUATING LEVER
  - 36 RETAINING BOLT
  - 37 RETAINING PIN
- G {
  - 38 DIRECT CLUTCH ACCUMULATOR SPRING
  - 39 OIL SEAL RING
  - 40 DIRECT CLUTCH 2-3 ACCUM. PISTON
  - 41 RETAINER RING

5B7C205-1

Figure 350C-110 Typical Valve Body

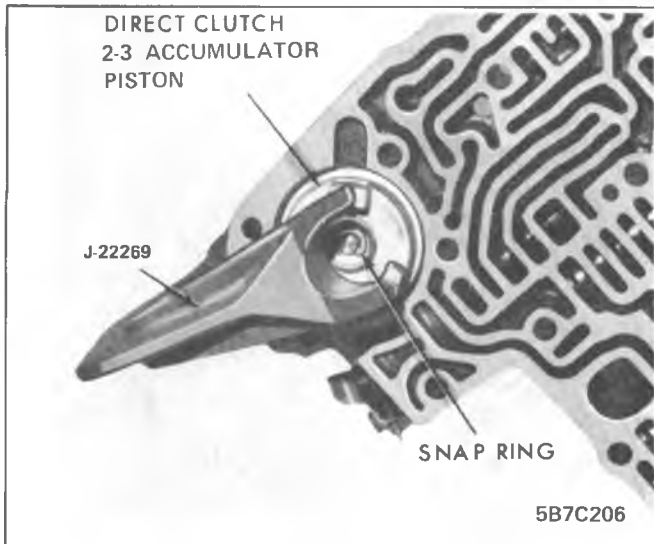

Figure 350C-111 Removing 2-3 Accumulator

**Inspection**

1. Inspect all valves for scoring, cracks and free movement in their respective bores.
2. Inspect valve body for cracks, scored bores, interconnected oil passages and flatness of mounting face.
3. Check all springs for distortion or collapsed coils.

**Reassembly**

1. Install direct clutch accumulator piston spring and piston into valve body.
2. Install J-22269 and J-24675 (installs piston evenly) on direct clutch 2-3 accumulator piston and compress spring and piston and secure with retaining ring. See Figure 350C-111. Align piston and oil seal ring when entering bore.
3. Install the detent valve, washer, outer spring, inner spring, spring seat, and spring retainer. Install detent valve stop and detent valve actuating bracket. Torque bolt to 52 lb. in. Assemble detent actuating lever with retaining pin.
4. Install the pressure regulator valve, spring, reverse and modulator boost valve, intermediate boost valve, boost valve sleeve and retaining pin.
5. In the next bore up, install 2-3 shift valve, shift valve spring, 2-3 shift control valve, shift control valve spring, shift control valve sleeve and retaining pin.
6. In the next bore up, install the 1-2 shift valve, 1-2 shift control valve, control valve spring, control valve sleeve and retaining pin.
7. In the next bore up, install the manual low control valve, spring, plug and retaining pin.
8. In the top right hand bore, install the detent regulator valve, spring seat, spring and retaining pin.

**INTRNAL PARTS**

**Installation**

**General Instructions**

1. Before starting to assemble the transmission make certain that all parts are *absolutely clean*. Keep hands and tools clean to avoid getting dirt into assembly. If work is stopped before assembly is completed cover all openings with clean cloths.

2. When reassembling it is important that all thrust washer surfaces be given an initial lubrication. Bushings should be lubricated with transmission fluid. Thrust washers should be lubricated on both surfaces with petrolatum before installation.
3. Use care to avoid making nicks or burrs on parts, particularly on surfaces where gaskets are used.
4. It is extremely important to tighten all parts evenly and in proper sequence, to avoid distortion of parts and leakage at gaskets and other joints. *Use a reliable torque wrench to tighten all bolts and nuts to specified torque and in the specified sequence.*

**Low and Reverse Clutch Piston**

1. Install low and reverse clutch piston outer seal, if previously removed. See Figure 350C-112.

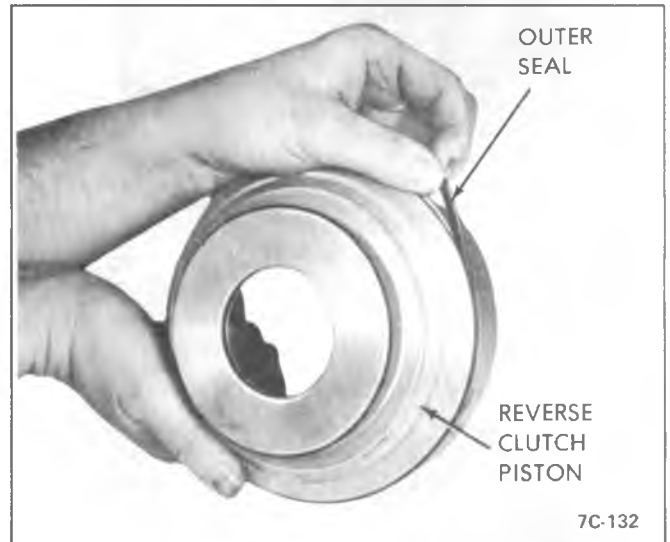

Figure 350C-112 Installation of Outer Seal

2. Install low and reverse clutch piston center and inner seal, if previously removed. See Figure 350C-113.

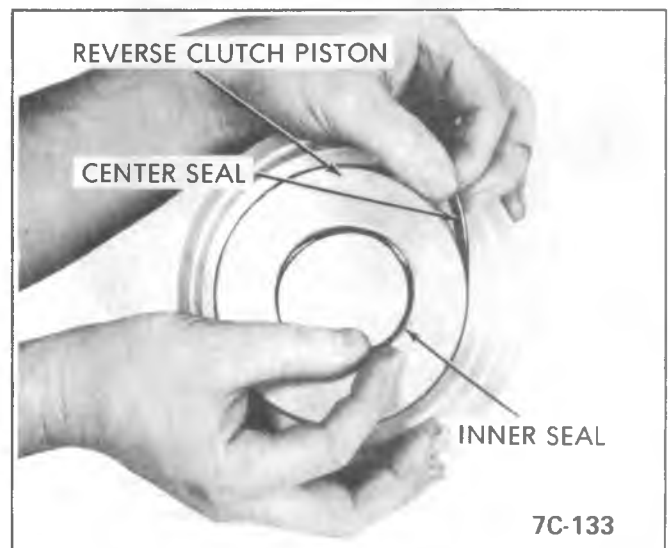

Figure 350C-113 Installation of Inner and Center Seal

3. Install low and reverse clutch piston assembly with notch in piston installed adjacent to parking pawl. See Figure 350C-115.



4. Position piston return seat and springs. Place snap ring on return seat so that ring may be easily installed when seat is compressed with Tool J-21420.
5. Using tool J-21420-1 compress return seat so spring retainer retaining ring may be installed with snap ring pliers. See Figure 350C-115.  
As spring retainer is compressed make certain inner edge of retainer does not hang up on snap ring groove.

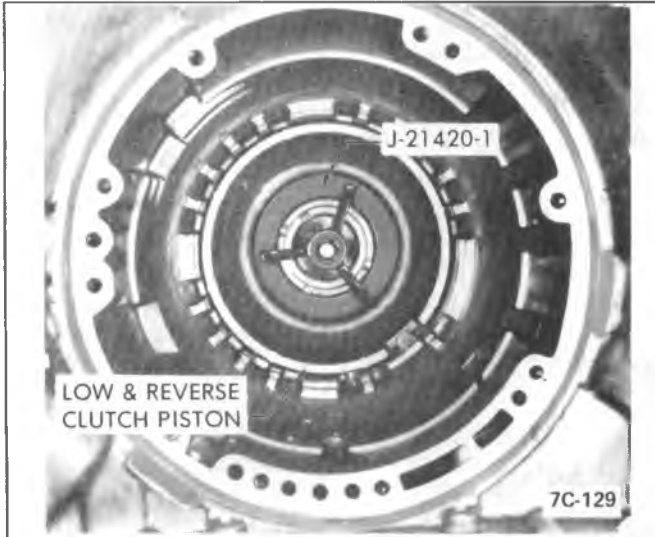

Figure 350C-115 Low and Reverse Piston Snap Ring

### Output Shaft and Reaction Carrier

1. Install output ring gear to output shaft and output ring gear to output shaft snap ring. See Figure 350C-117. **DO NOT OVER STRESS SNAP RING ON ASSEMBLY. ALWAYS USE NEW RING ON REASSEMBLY.**
2. Install reaction carrier to output ring gear needle thrust bearing with lip side face up. See Figure 350C-117.

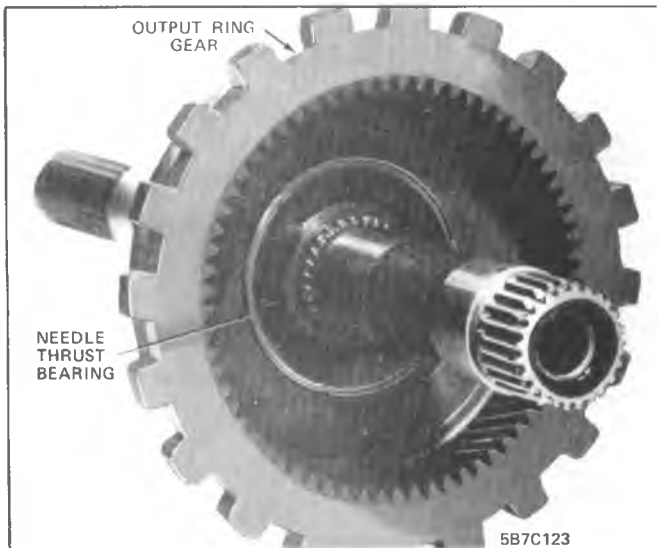

Figure 350C-117 Needle Bearing Assembly

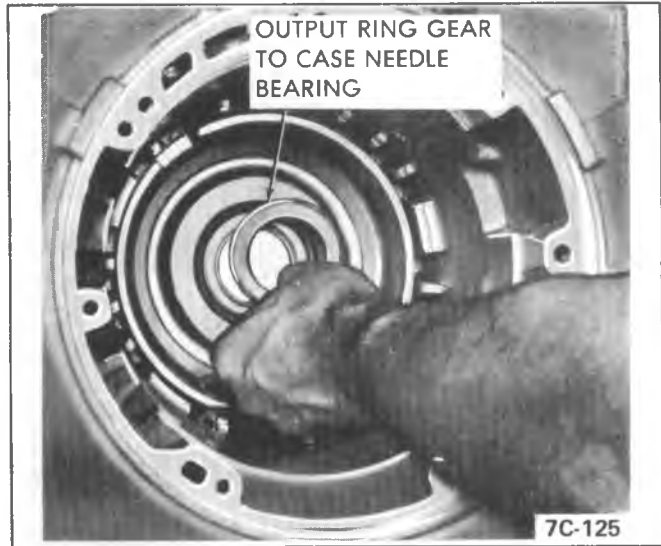

Figure 350C-118 Needle Bearing Assembly

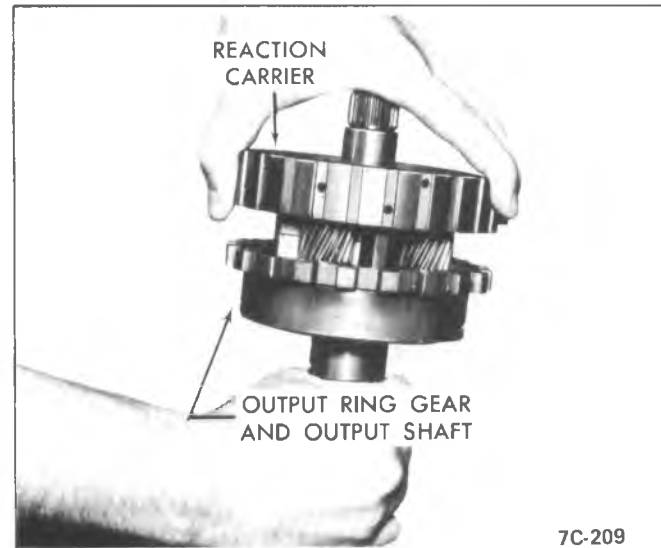

Figure 350C-119 Installing Reaction Carrier

### Low and Reverse Clutch Plates

Refer to specifications in rear of this section to determine the required amount of lined and steel clutch plates to use with specific transmission model and engine combination. When replacing piston assembly specific part number must be used.

1. Oil and install low and reverse clutch steel separator plates and faced plates, starting with a steel plate and alternating with faced plates. See Figure 350C-120.
2. Install low and reverse clutch support retainer spring. See Figure 350C-121.
3. Install low and reverse clutch support assembly pushing firmly until support assembly is seated past top of low and reverse clutch support retainer spring so retaining ring can be installed. See Figure 350C-122.

Make certain the splines on inner race of the roller clutch align with splines on reaction carrier.

4. Install low and reverse clutch support to case retaining ring. See Figure 350C-121.

3. Install output ring gear to case needle bearing assembly. See Figure 350C-118. Lip on inner race of bearing **MUST** point toward rear of transmission.
4. Install reaction carrier assembly into output ring gear and shaft assembly. See Figure 350C-119.
5. Install output shaft and reaction carrier assembly into case.

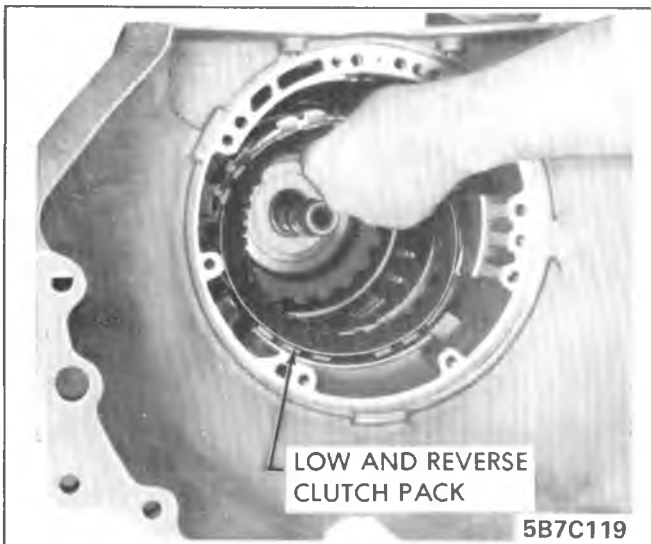

Figure 350C-120 Installing Low and Reverse Clutch Plates

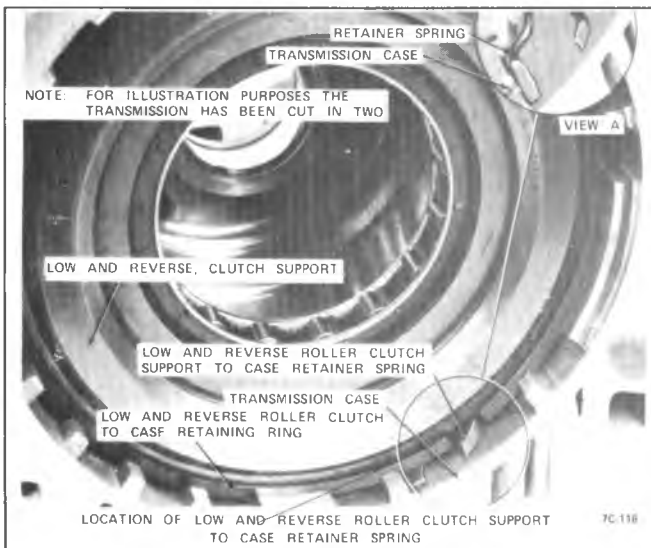

Figure 350C-121 Retainer Location

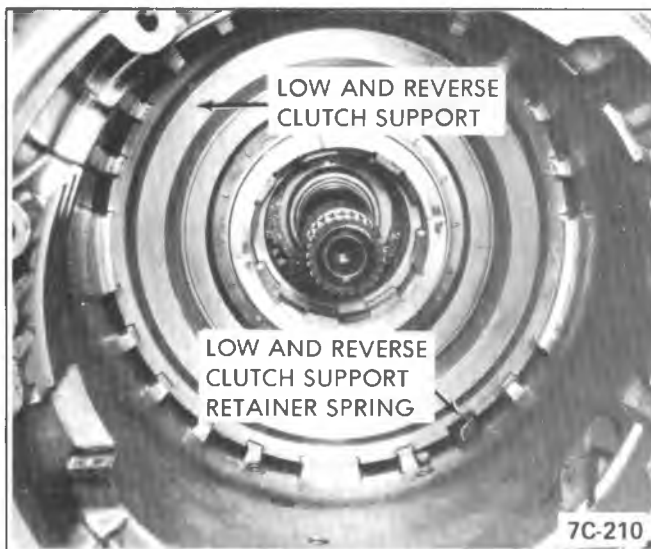

Figure 350C-122 Low and Reverse Clutch Support

### Sun Gear Drive Shell Assembly

1. Install low and reverse clutch support inner race to sun gear drive shell thrust washer and install sun gear drive shell assembly. See Figure 350C-123.

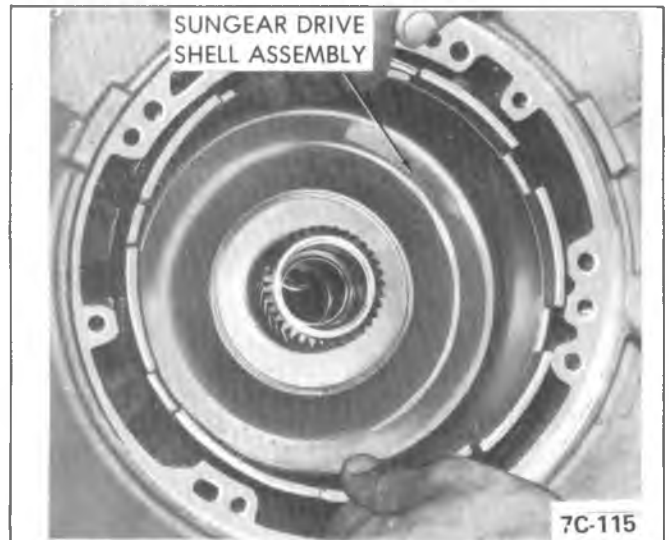

Figure 350C-123 Sun Gear Drive Shell Assembly

### Output Carrier Assembly

1. Install output carrier assembly. See Figure 350C-124.

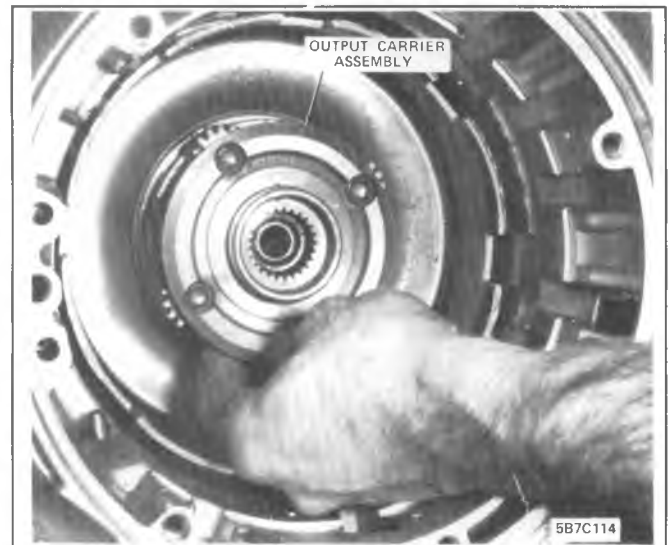

Figure 350C-124 Install Output Carrier

2. Install input ring gear to output carrier needle thrust bearing lip side face down. See Figure 350C-125.
3. Install output carrier to output shaft snap ring. Use new snap ring and do not over stress on installing. See Figure 350C-125.

### Input Ring Gear

1. Install input ring gear. See Figure 350C-126.
2. Install forward clutch housing to input ring gear front thrust washer. See Figure 350C-120. Washer has three (3) tangs.

### Direct and Forward Clutch Assemblies

1. Install direct clutch drum to forward clutch housing needle roller bearing. See Figure 350C-127.



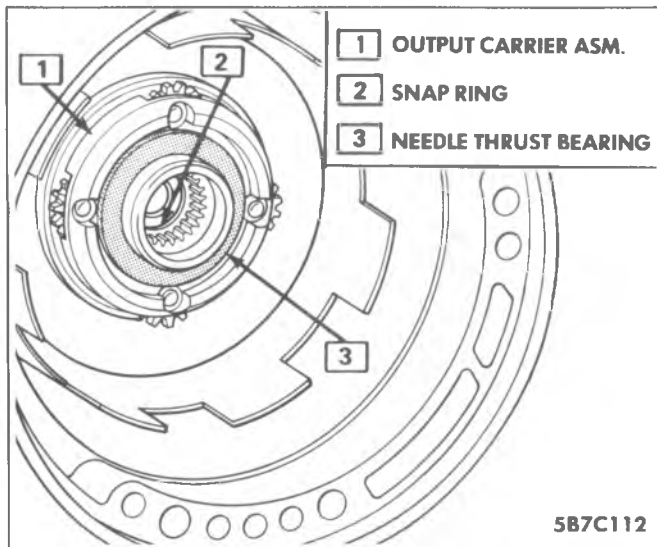

Figure 350C-125 Output Carrier Needle Bearing

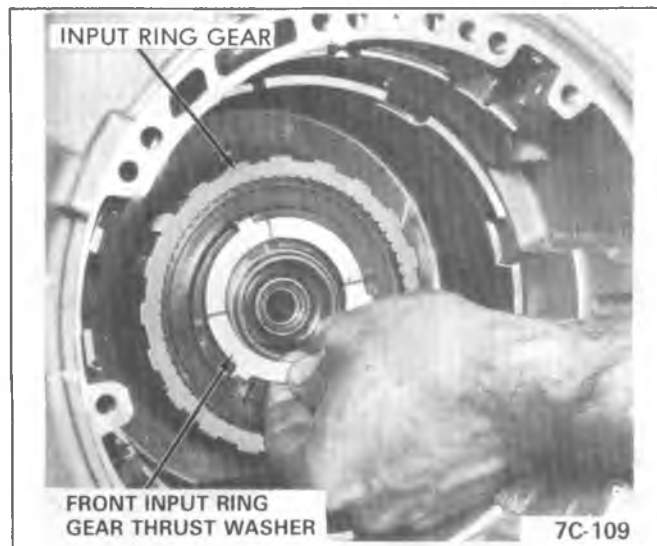

Figure 350C-126 Input Ring Gear Thrust Washer

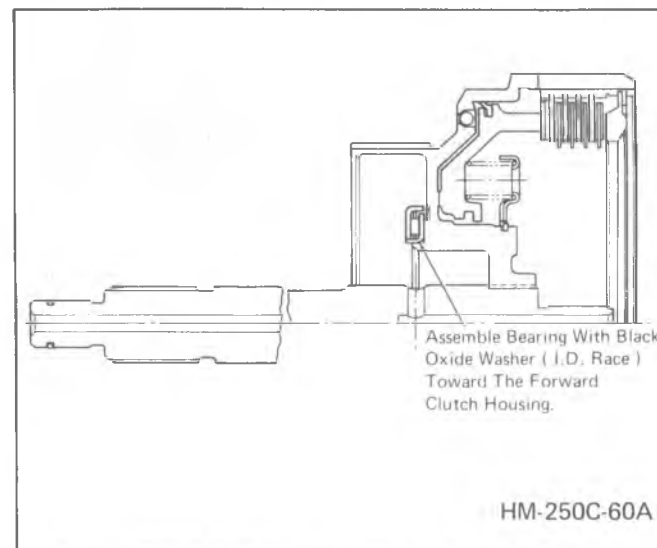

Figure 350C-127 Forward Clutch Needle Bearing

2. Install direct clutch assembly to forward clutch assembly. Install assemblies into case making certain

forward clutch faced plates are positioned over input ring gear and the tangs on direct clutch housing are installed into slots on the sun gear drive shell. See Figure 350C-128.

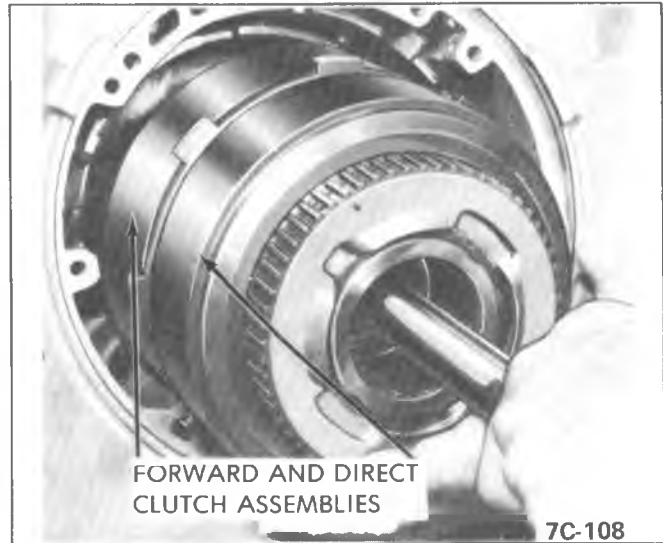

Figure 350C-128 Install Forward and Direct Clutch Assembly

### Intermediate Clutch Overrun Brake Band

1. Install intermediate clutch overrun brake band. See Figure 350C-129.

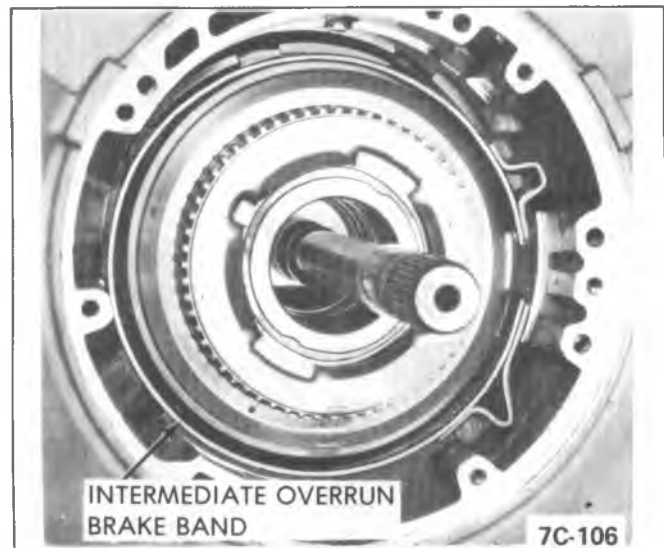

Figure 350C-129 Install Intermediate Band

### Intermediate Clutch Pressure Plate, Clutch Plates, and Cushion Spring

Refer to specifications in rear of this section to determine the required amount of composition and steel clutch plates to use with specific transmission model and engine. When replacing piston assembly specific part number must be used.

1. Install intermediate clutch pressure plate. See Figure 350C-130.
2. Oil and install composition and steel intermediate clutch plates, starting with a lined plate and alternating steel and lined.
3. Install intermediate clutch cushion spring.

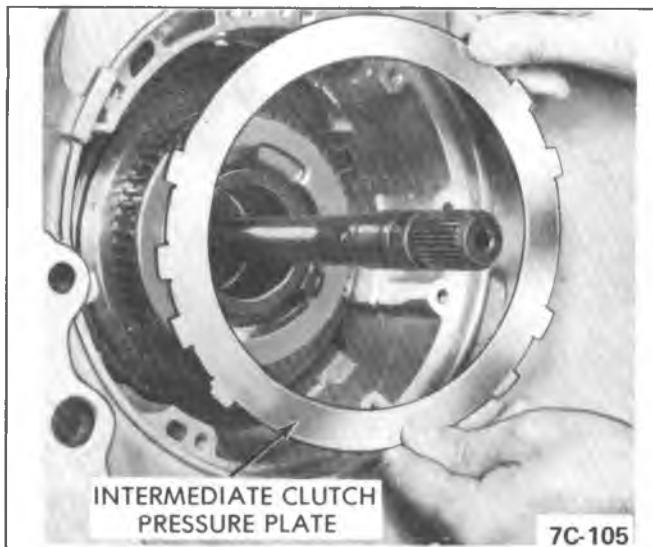

Figure 350C-130 Intermediate Clutch Pressure Plate

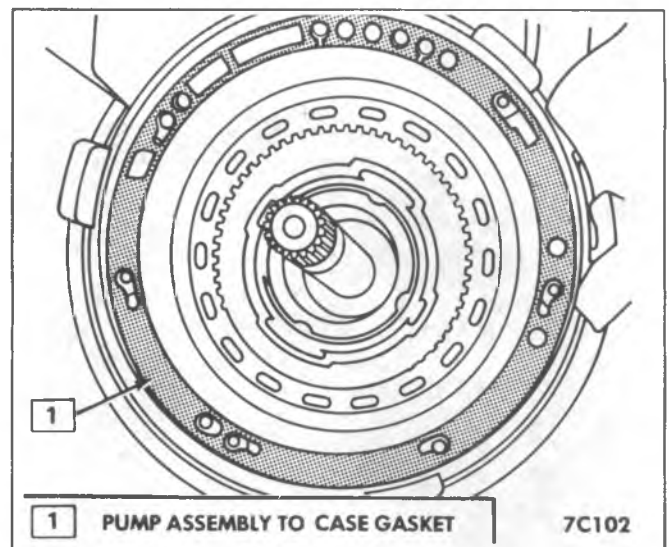

Figure 350C-134 Pump Gasket

### Oil Pump Assembly

1. Install original amount of .017 shims, and needle thrust bearing lip side face down on pump cover hub. Before installation apply petrolatum to both sides of shim and bearing. See Figure 350C-133.

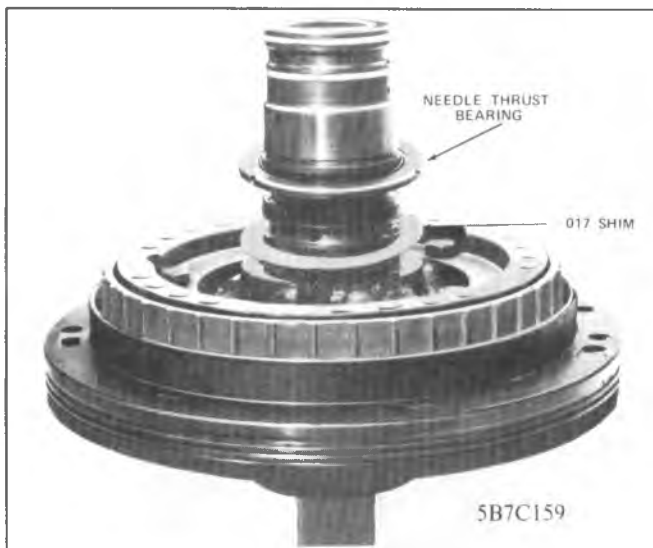

Figure 350C-133 Pump Shim and Needle Bearing

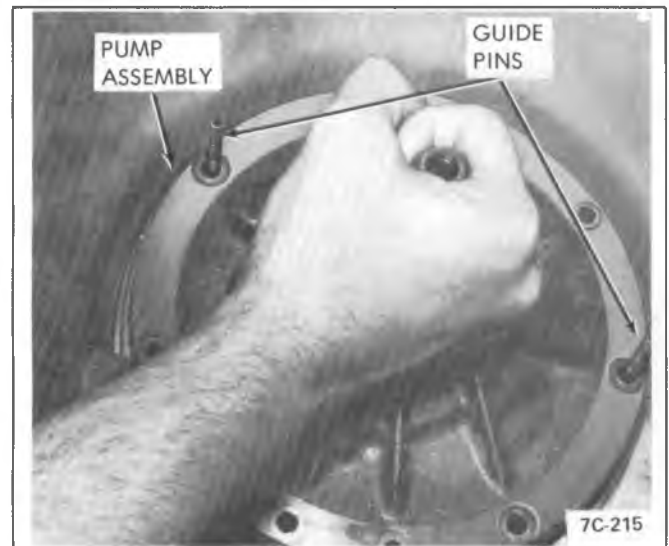

Figure 350C-135 Installing Pump

forward, the reading obtained should be between .010 and .044. If the reading is incorrect remove pump assembly and install enough .017 shims to obtain correct reading. See Figure 350C-133.

### EXTERNAL PARTS — INSTALLATION

#### Speedometer Drive Gear

1. Place speedometer drive gear retaining clip into hole in output shaft. See Figure 350C-137.
2. Align slot in speedometer drive gear with retaining clip and install. See Figure 350C-137.

#### Extension Housing

1. Install extension housing to case square cut seal. See Figure 350C-138.
2. Attach extension housing to case using attaching bolts. Torque to 35 ft.lbs. (47 N·m).
3. Install speedometer driven gear, retainer and bolt. Torque bolt to 12 ft.lbs. (16 N·m).

#### Parking Pawl and Actuating Rod

If internal linkage was removed proceed as follows:

1. Install parking pawl, tooth toward the inside of case. See Figure 350C-140.

2. Install new pump assembly to case gasket. See Figure 350C-134. Before installing pump lubricate case bore.
3. Install guide pins into case. Install pump assembly into case, remove guide pins and install pump to case bolts. Using new washer type seals tighten alternately to 20 ft. lbs. (27 N·m) torque. See Figure 350C-135.
4. If input shaft cannot be rotated as the pump is being pulled into place, the direct and forward clutch housings have not been properly installed to index the composition plates with their respective parts. This condition must be corrected before the pump is pulled into place.
5. Checking direct clutch to oil pump clearance, attach slide hammer bolt to threaded hole in oil pump. See Figure 350C-136. With flat of hand on end of input shaft move shaft rearward. Install Dial Indicator Set J-8001 on rod and "O" dial indicator on end of input shaft. Push on end of output shaft to move shaft

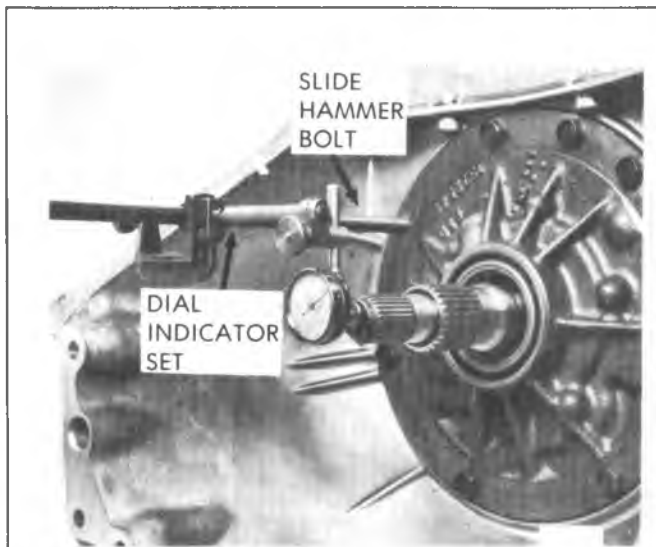

Figure 350C-136 Checking End-Play Output Shaft Sleeve & O Ring

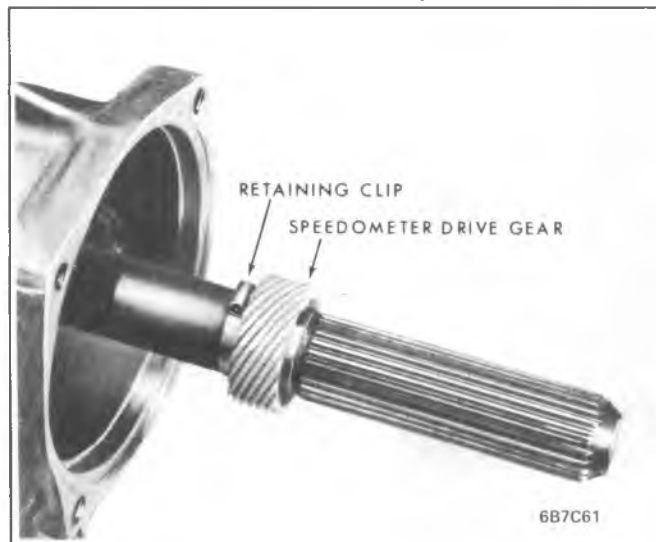

Figure 350C-137 Speedo Gear and Clip

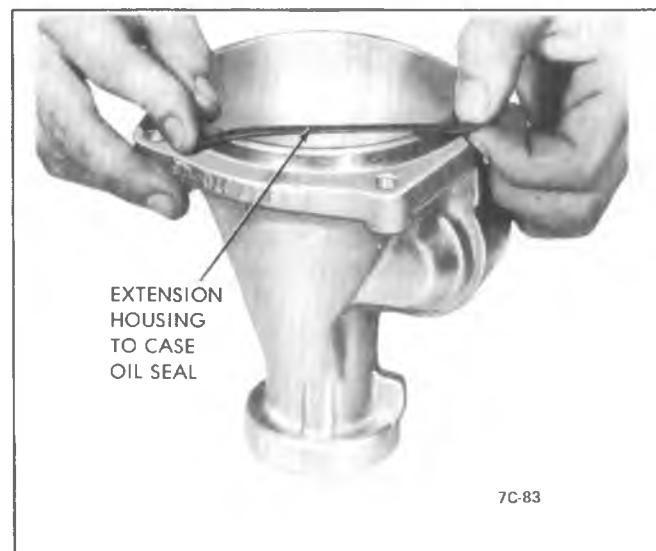

Figure 350C-138 Extension Oil Seal

2. Install parking pawl shaft into case through disengaging spring. Install disengaging spring on

parking pawl and slide shaft through parking pawl. See Figure 350C-140.

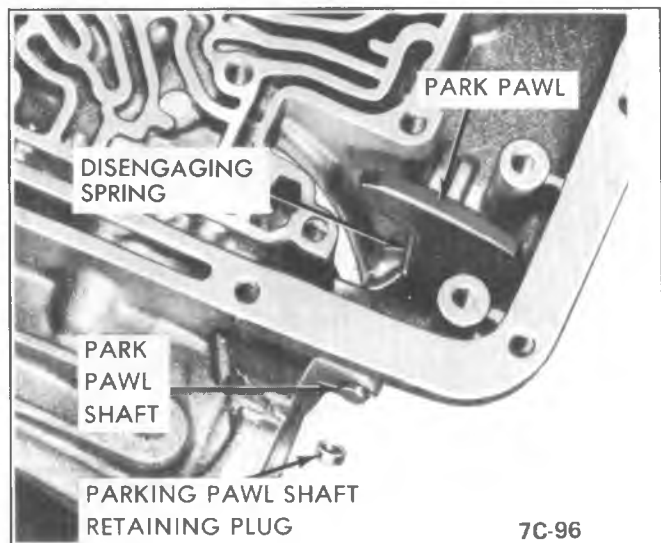

Figure 350C-140 Parking Pawl Shaft and Retaining Plug

3. Install parking pawl shaft retainer plug. Drive into case using a 3/8" dia. rod, until retainer plug is flush to .010" below face of case. Stake plug in three (3) places to retain plug in case. See Figure 350C-141.

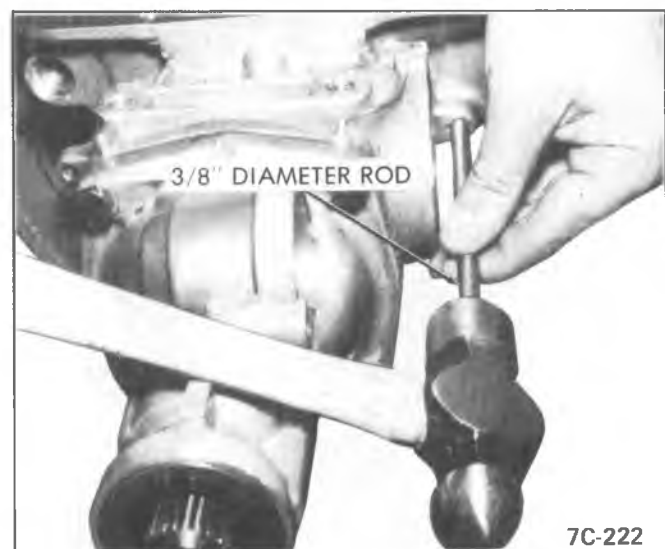

Figure 350C-141 Install Retaining Plug

4. Install park lock bracket, torque bolts to 29 ft.lbs. (39 N·m). See Figure 350C-142.
5. Install actuating rod under the park lock bracket, and parking pawl. See Figure 350C-143.

### Manual Shaft and Range Selector Inner Lever

1. If a new manual shaft to case lip seal is necessary, use a 7/8" diameter rod and seat flush with case. See Figure 350C-144.
2. Install manual shaft through case and range selector inner lever.
3. Install retaining jam nut on manual shaft. Torque jam nut to 30 ft.lbs. (40 N·m). See Figure 350C-145. Install manual shaft to case retainer.

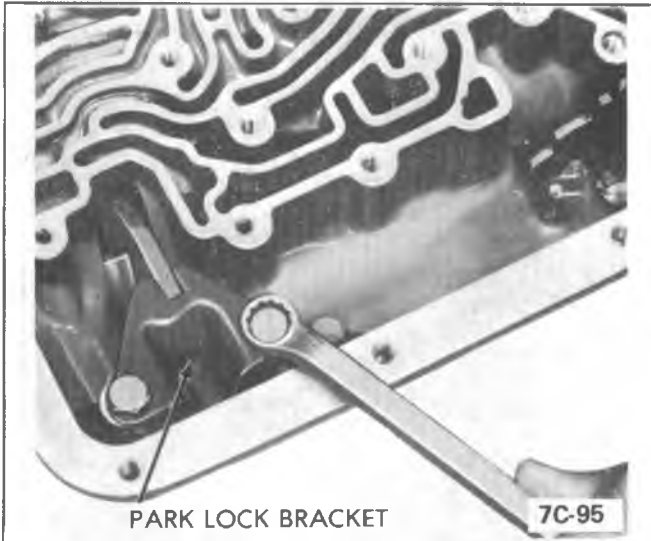

Figure 350C-142 Install Park Lock Bracket

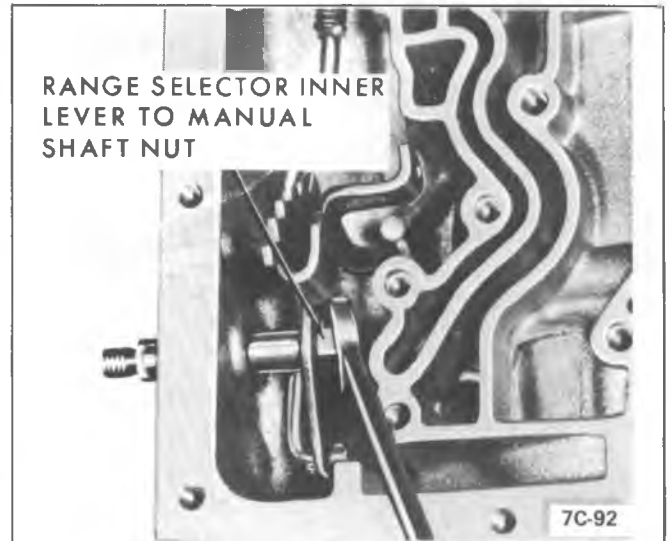

Figure 350C-145 Manual Shaft Nut

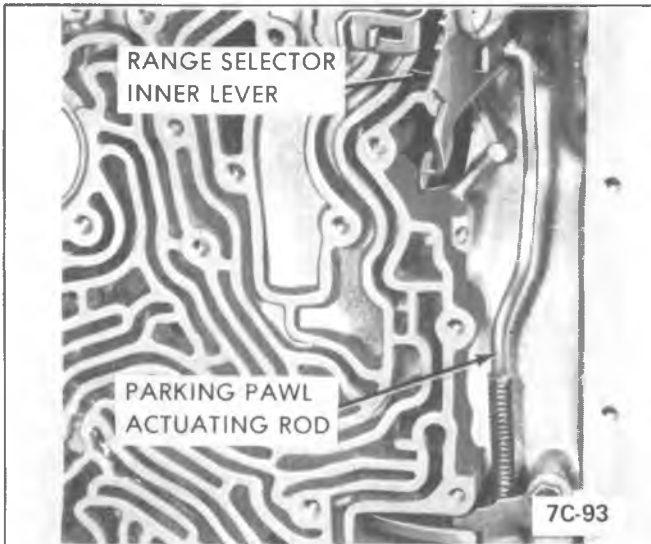

Figure 350C-143 Actuating Rod

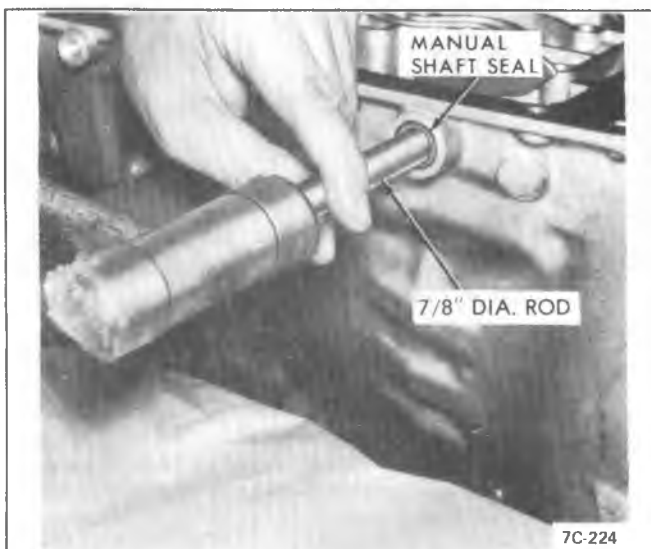

Figure 350C-144 Seal Installation

### Intermediate Servo Piston, Check Balls, Oil Pump Pressure Screen and Governor Feed Screens

1. Install park lock bracket and special bolts.
2. Install intermediate servo piston, apply pin, spring seat. See Figure 350C-146.

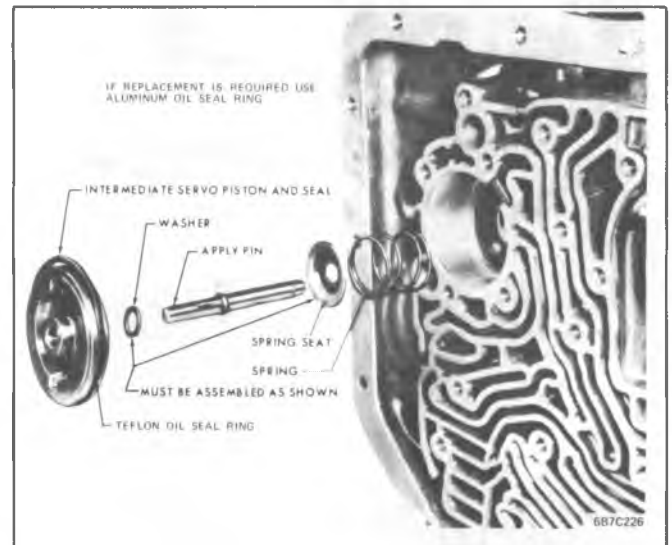

Figure 350C-146 Intermediate Servo Assembly

3. Install 5 check balls into correct transmission case pockets. See Figure 350C-146A. If number one (1) check ball is omitted or incorrectly placed, transmission failure will result due to minimum line pressure.
4. Install oil pump pressure screen in the oil pump pressure hole in case. Open end of screen must be installed toward case face. See Figure 350C-149. (*Clean before installing.*)
5. Install governor screen in the case. See Figure 350C-150. (*Clean before installing.*)
6. If removed, install case electrical connector with new "O" ring seal.

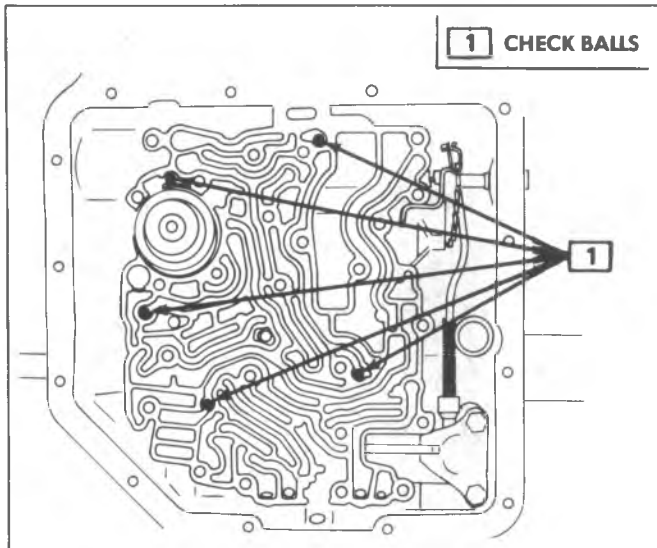

Figure 350C-146A Check Ball Locations

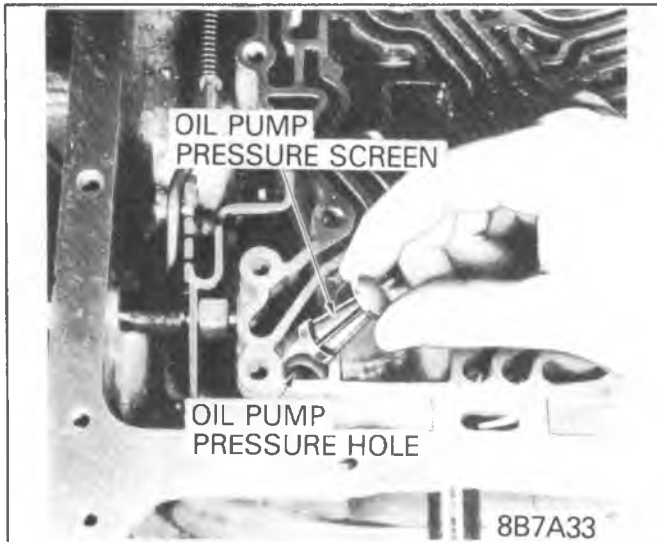

Figure 350C-149 Pump Screen

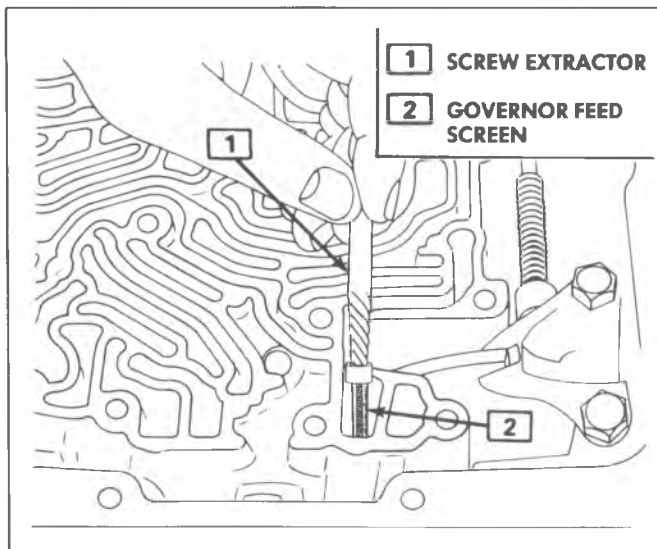

Figure 350C-150 Installing Governor Feed Screen

### Valve Body, Detent Roller and Spring Assembly, and Filter

1. Install valve body spacer plate to case gasket, valve body spacer plate and spacer plate to valve body gasket. (This gasket has a yellow ink stripe for identification purposes.) See Figure 350C-152.

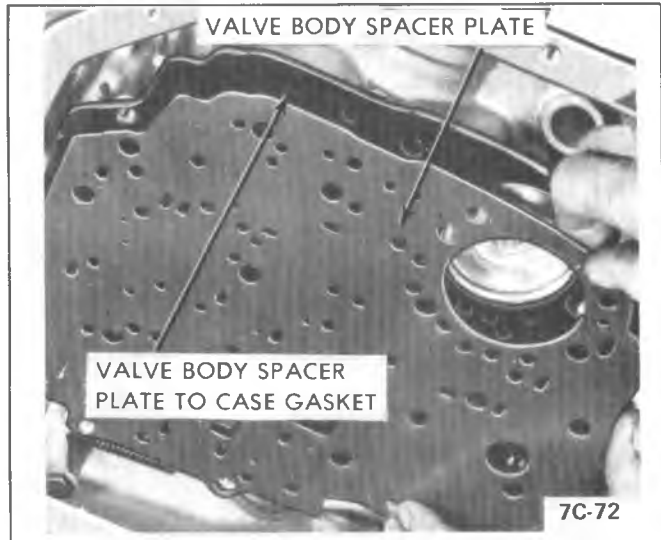

Figure 350C-152 Spacer Plate and Gaskets

2. Install spacer support plate. Torque bolts to 13 ft.lbs. (18 N·m). See Figure 350C-153.
3. Install auxiliary valve body, torque bolts to 13 ft. lbs.

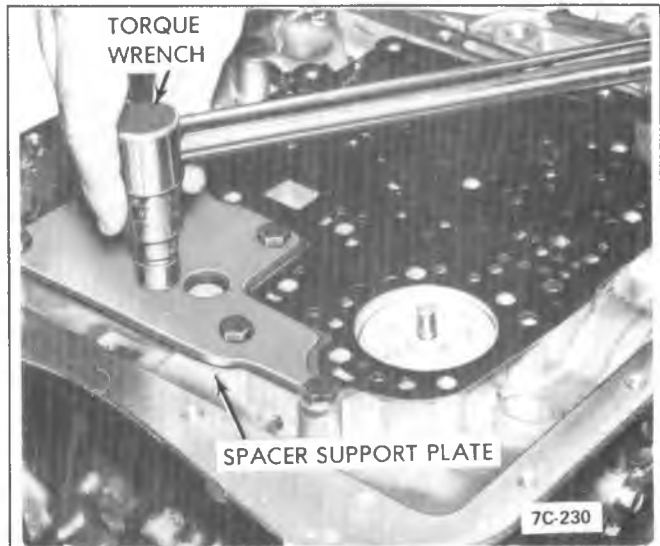

Figure 350C-153 Support Plate

4. Install valve body. Connect manual control valve link to range selector inner lever. Install manual shaft retaining clip. Torque bolts in random sequence to 13 ft.lbs. leaving bolt loose for detent roller and spring assembly. See Figure 350C-153A. When handling valve body assembly do not touch sleeves as retainer pins may fall into transmission.
5. Install detent roller and spring assembly to valve body. See Figure 350C-153A.
6. Install detent control valve wire to detent valve actuating lever, then attach lever to valve body.
7. Install solenoid and connect wires (if removed, install governor pressure switch).



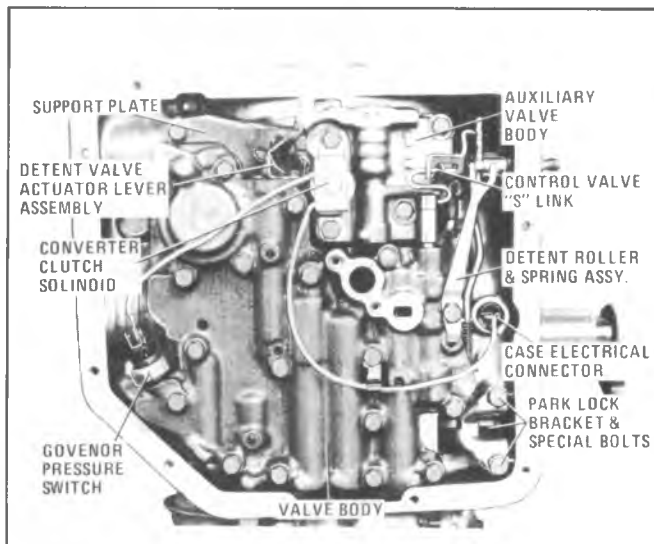

Figure 350C-153A

8. Install filter and gasket assembly. Install filter and gasket exactly as shown. Always replace filter when foreign material is found to be present.

### Oil Pan, Governor, and Modulator Valve

1. Install new bottom pan gasket and bottom pan.
2. Install governor assembly. Check governor dowel pin for proper dimension, and looseness. If pin is too high tap down to proper dimension. However, if the pin is installed too low or loose, the case must be replaced. See Figure 350C-160. Uniformly apply Loctite Cup Plug Sealant #2 or equivalent to governor cover O.D. and install by gently tapping into place with a plastic or rawhide hammer. If cover is damaged it must be replaced.
3. Install vacuum modulator valve and modulator. See Figure 350C-162. Lubricate "O" ring seal to prevent damage, install retaining clip, and torque bolt to 12 ft. lbs. (16 N·m).

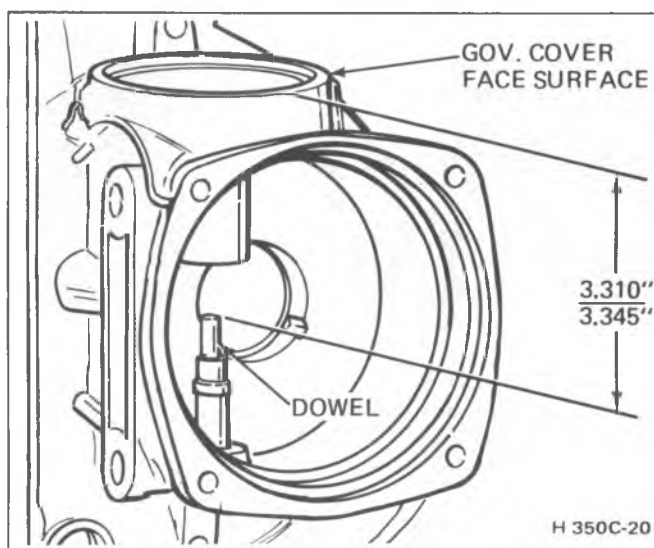

Figure 350C-160 Dowel Pin Dimension

### Converter

1. Install converter, making sure that the converter hub engages the drive lugs inside the pump gear. If they are not correctly engaged, pump damage will occur.

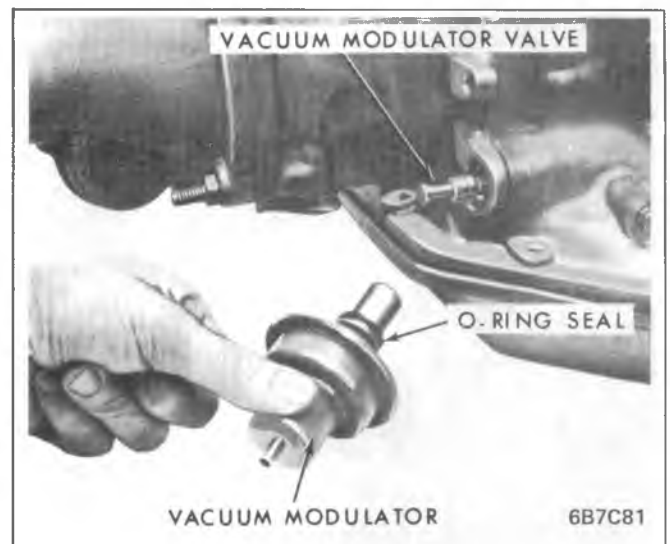

Figure 350C-162 Install Modulator

2. Check the converter to be sure that it turns freely and is able to move forward to meet the flywheel.

## BUSHING REPAIR

### GOVERNOR BUSHING

#### Removal

1. Remove transmission from car.
2. Remove the output shaft, valve body, support plate, and governor from the case.
3. Assemble transmission case in fixture J-8763 and mount in a vise. See Figure 350C-162.
4. Clean off excess stock from the governor o-ring seal to case mating surface. See Figure 350C-163.

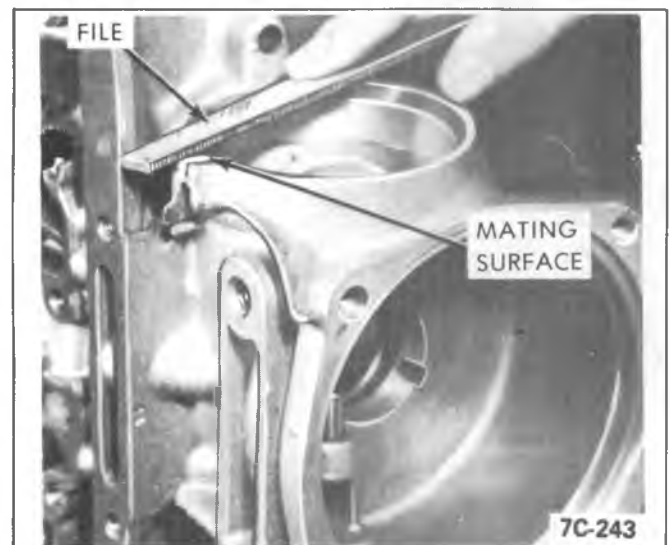

Figure 350C-163 Removing Excess Material From Governor Surface

5. Loosely bolt the drill bushing fixture J- 22976-11 to the case.
6. Place the alignment arbor J-22976-13 into the drill bushing fixture and down into the governor bore until it bottoms on the dowel pin. See Figure 350C-164.
7. Torque the bolts on the drill bushing fixture 10 ft. lbs. (13 N·m). *Do not over torque and strip the threads.* The alignment arbor should be able to rotate freely after the bolts are properly torqued. If the alignment

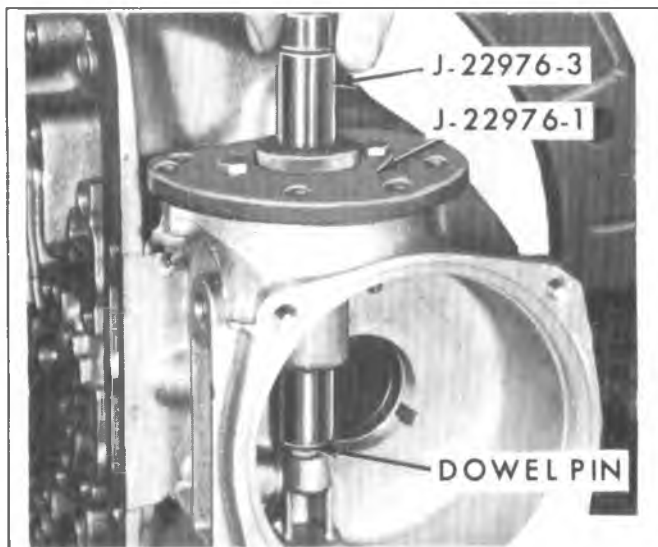

Figure 350C-164

arbor cannot be rotated by hand, recheck the work performed in step 4.

8. Remove the alignment arbor.
9. Using reamer J-22976-9 and drive ratchet, *hand* ream the governor bore using the following procedure: (*Hand Ream Only*)
  - a. Oil the reamer, drill bushing, and governor bore.
  - b. Use 7 lbs. of feeding force on the reamer. See Figure 350C-165.

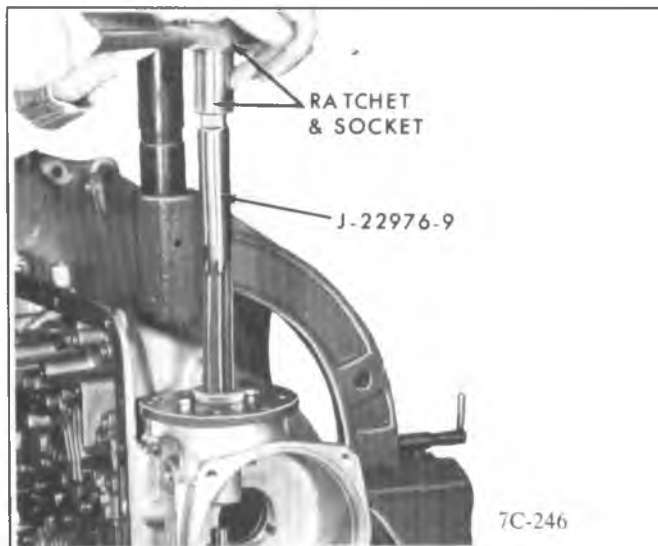

Figure 350C-165 Reamer

- c. *After each 10 revolutions* remove the reamer and dip it into a cup full of transmission oil. This will clean the chips from the reamer and lubricate it. See Figure 350C-166.
- d. When the reamer reaches the end of the bore, continue reaming the bore until the reamer bottoms out on the dowel pin in the case. *At this point, rotate the reamer 10 complete revolutions.*
- e. Remove the reamer using a clockwise rotation and 7-10 lbs. force upward.

Pulling the reamer out without rotating it may score the bore causing a leak between the case and the bushing.

10. Remove the drill bushing fixture from the case.

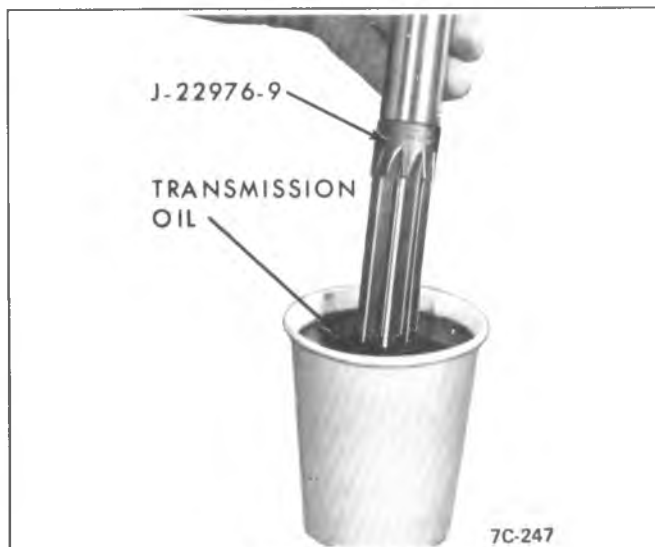

Figure 350C-166

11. Thoroughly clean the chips from the case, visually check the governor feed holes to insure that they are free from chips.

#### Installation

1. Install the bushing using the following procedure:
  - a. Note the two (2) notches at one end of the bushing.
  - b. Position the notches so that one notch is toward the front of the case and the other is toward the bottom of the case. See Figure 350C-167.

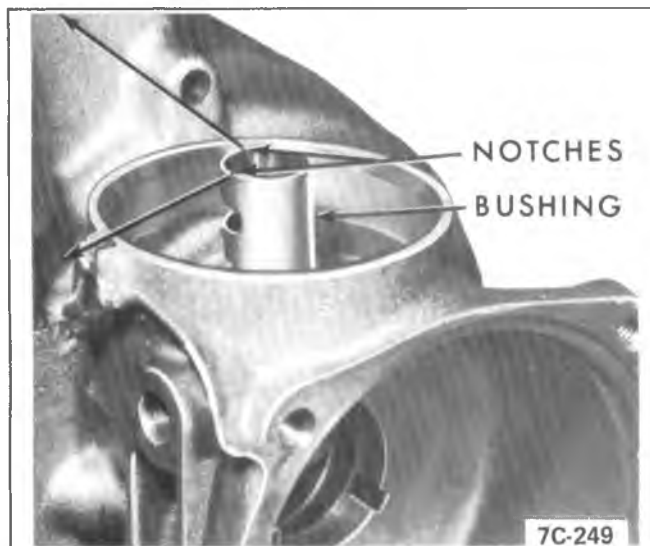

Figure 350C-167 Position Notches

- c. Use J-22976-13 alignment arbor and bushing installer to drive the bushing into the case. See Figure 350C-168. A brass hammer should be used to strike the hardened steel bushing installer tool.
- d. Drive the bushing until it is flush with the top of the bore and seated properly in the case. See Figure 350C-169.
2. Oil a new governor and insert it into the installed bushing. The governor should spin freely. If slight honing on the bushing is necessary, use crocus or fine emery cloth and move in a circular one-way direction only.

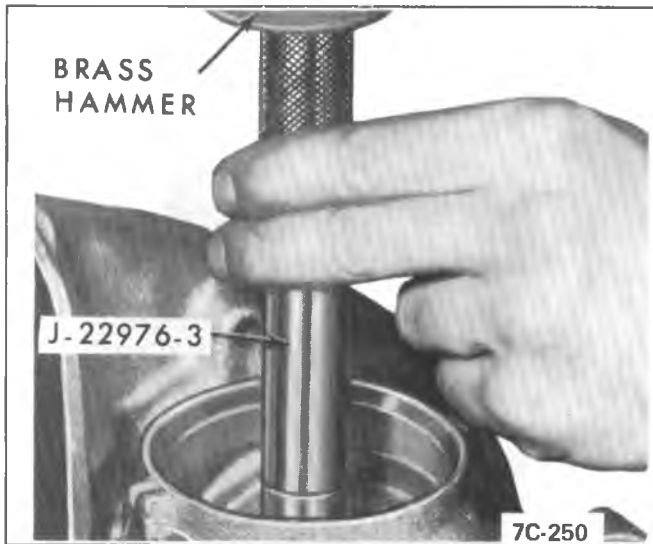

Figure 350C-168 Bushing Installer

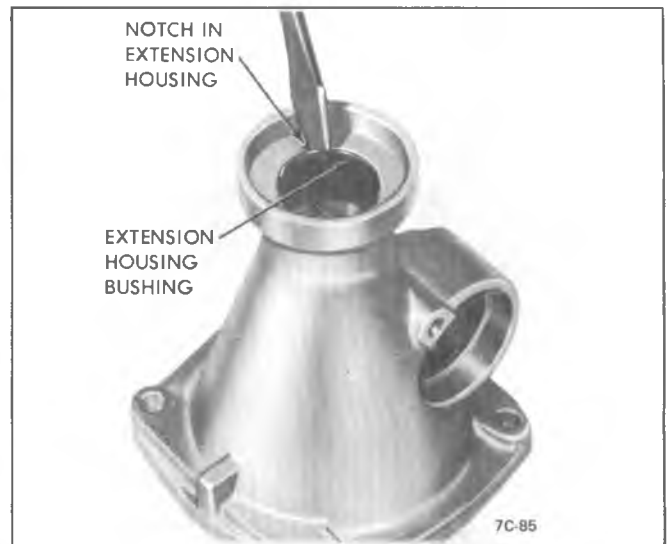

Figure 350C-170 Collapsing Bushing

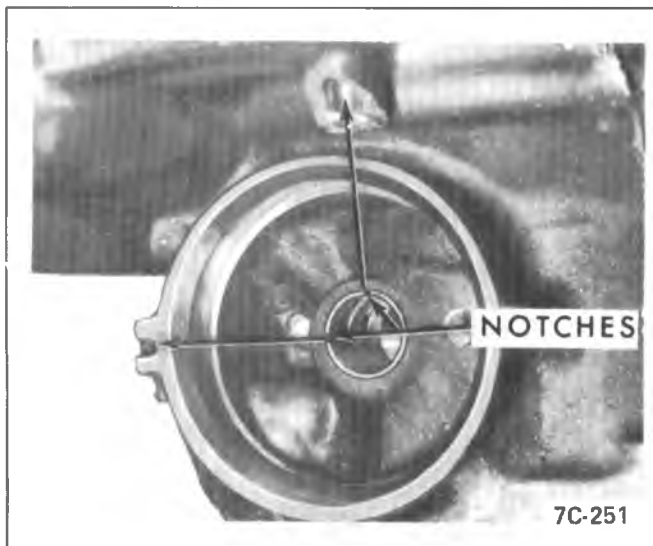

Figure 350C-169 Bushing Properly Seated

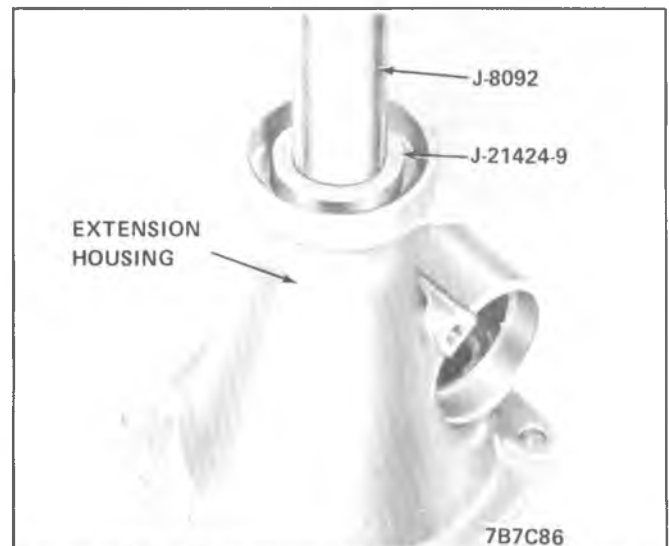

Figure 350C-171 Installing Extension Housing Bushing

## Extension Housing Bushing

### Removal

1. Remove extension housing bushing using screwdriver to collapse bushing. See Figure 350C-170.

### Installation

1. Install extension housing bushing using drive handle J-8092 and Bushing Tool J-21424-9. See Figure 350C-171.

## Input Ring Gear Bushing

### Removal and Installation

1. Inspect bushing for wear or galling. If replacement is necessary, proceed as follows:
  - a. Thread Tool J-23062-15 on Drive Handle J-8092, and remove bushing from ring gear. See Figure 350C-172.
  - b. Using Tool J-23062-15, press in new bushing .050" to .060" from inner surface of hub. See Figure 350C-172.

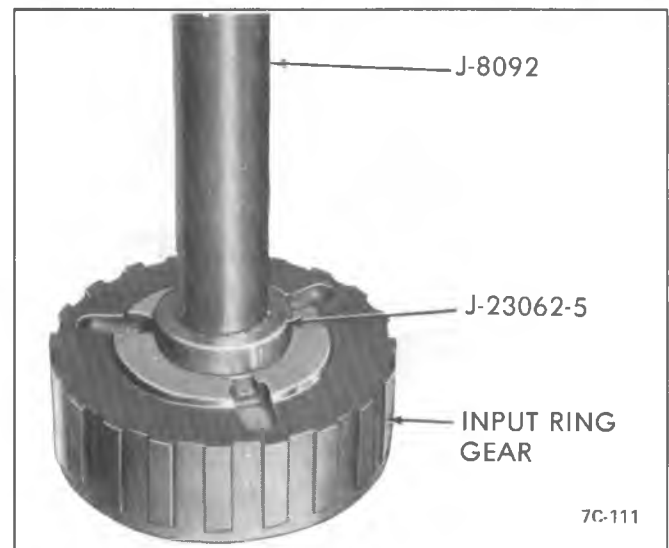

Figure 350C-172 Reaction Carrier Bushing Removal



## Reaction Carrier Bushing

### Removal and Installation

1. Inspect reaction carrier bushing for wear or galling. If replacement is necessary, proceed as follows:
  - a. Thread Tool J-23062-13 on Drive Handle J-8092 and remove bushing. See Figure 350C-173.
  - b. Using Tool J-23062-13, press in new bushing flush to .010" from inner surface of hub. See Figure 350C-173.

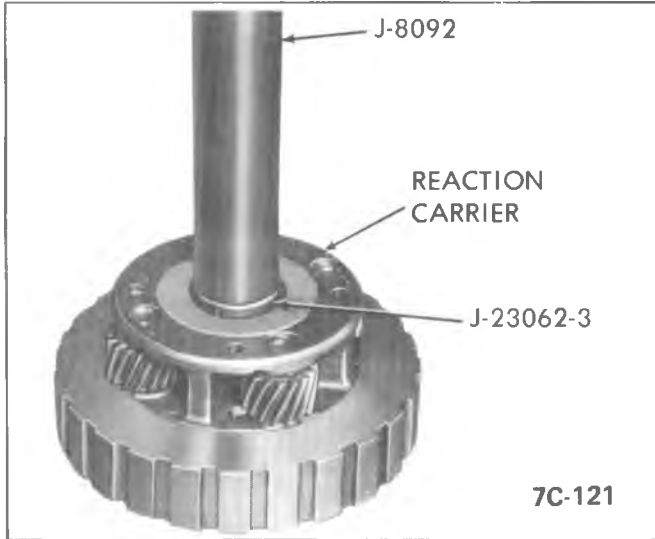

Figure 350C-173 Reaction Carrier Bushing Installation

## Case Bushing

### Removal

1. Inspect case bushing for nicks, scoring or excessive wear. If damaged, remove as follows: Assemble Tool J-23062-116 on Drive Handle J-8092. Place Tool J-23062-8 into back of case, insert assembly of drive handle J-8092 and Tool J-23062-116 into Tool J-23062-8 and remove bushing. See Figure 350C-174.

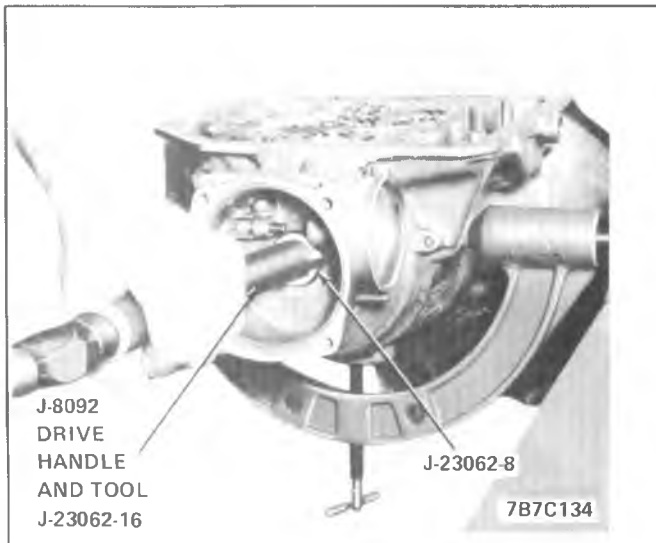

Figure 350C-174 Removing Case Bushing

### Installation

1. Using Tool J-23062-11 and Drive Handle J-8092, press bushing to 1/5" below chamfered edge of case. Make

certain split in bushing is opposite notch in case. See Figure 350C-175.

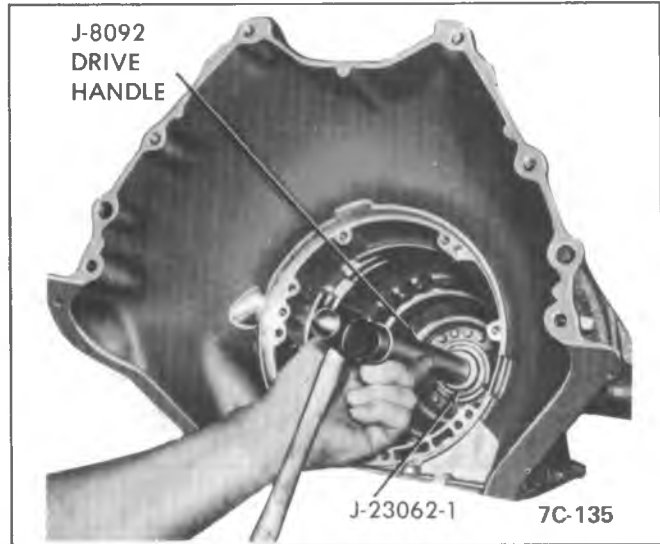

Figure 350C-175 Installing Case Bushing

## Pump Body Bushing

### Removal and Installation

1. Check oil pump bushing for nicks, severe scoring or wear. If bushing replacement is necessary, remove as follows: Support pump on wood blocks. Use Tool J-21465-117 and Drive Handle J-8092 to press bushing out of pump body. To install new oil pump bushing, use Tool J-21465-117 and Drive Handle J-8092 and press bushing into pump body from gear pocket face until it is flush to .010" below opposite face. (Front pump seal side). See Figure 350C-176.

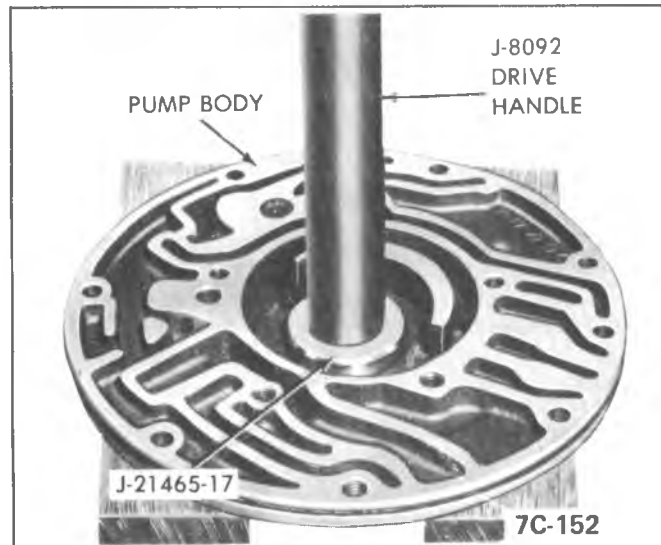

Figure 350C-176 Pump Bushing Removal

## Front Stator Shaft Bushing

### Removal

1. Check front stator shaft bushing for nicks, severe scoring or wear. If bushing replacement is necessary, remove as follows: Assemble bushing remover J-21465-115 to adapter J-2619-14. Assemble this assembly into slide hammer J-2619. Clamp slide

hammer into vise. Grasp stator shaft and remove bushing. See Figure 350C-177.

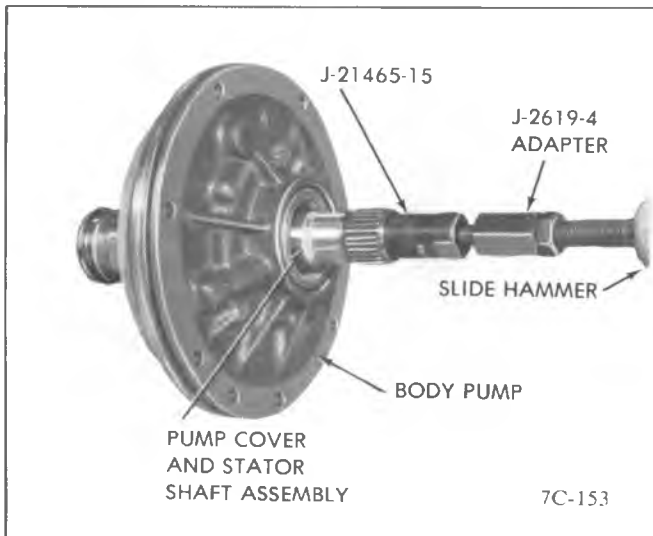

Figure 350C-177 Remove Front Stator Shaft Bushing

**Installation**

1. Install front stator shaft bushing as follows: Support pump assembly on J-21424-17 before installing bushing. Install bushing into the front end of stator shaft. Using installer J-21424-17 and Drive Handle J-8092, tap bushing into shaft 1/4 inch below top of stator shaft. See Figure 350C-178. Extreme care must be taken so bushing is not driven past shoulder.

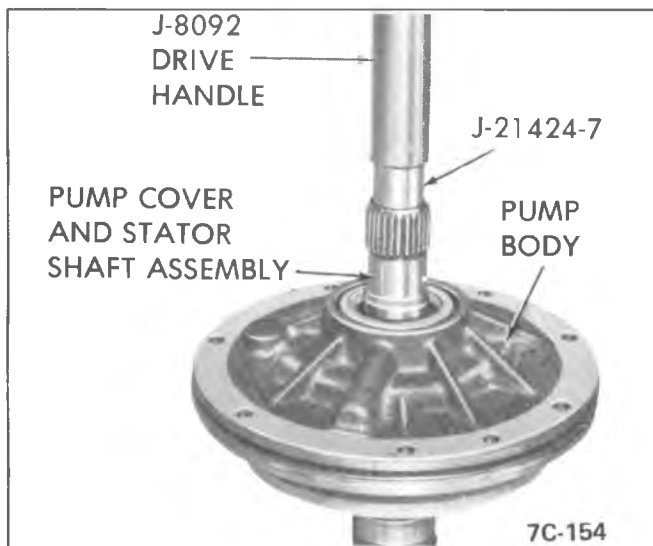

Figure 350C-178 Install Front Stator Shaft Bushing

**Rear Stator Shaft Bushings**

**Removal**

1. If replacement at lower rear stator shaft bushing is required, proceed as follows: Thread Tool J-21465-115 into stator shaft lower rear bushing. Thread slide hammer J-2619 into remover. Clamp slide hammer into vise. Grasp stator shaft and remove bushing. See Figure 350C-179. If upper rear stator shaft bushing is required, repeat above procedure.

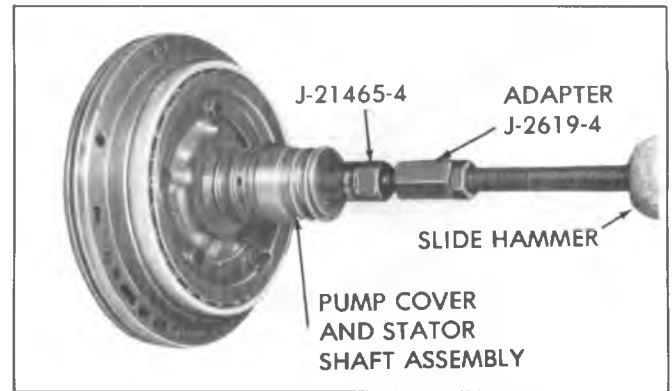

Figure 350C-179 Remove Rear Stator Shaft Bushing

**Installation**

1. Using Tool J-23062-12, press upper rear stator shaft bushing to 1-11/32 inch below top surface of oil pump delivery sleeve. See Figure 350C-180.

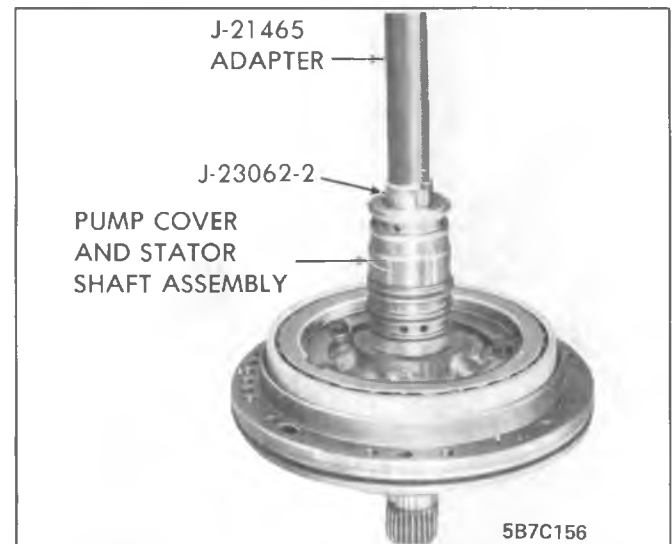

Figure 350C-180 Install Rear Stator Shaft Bushing

2. Using Tool J-23062-12, press lower rear stator shaft bushing flush to .010" below chamfer on oil pump delivery sleeve.

**Direct Clutch Bushing**

**Removal**

1. If bushing replacement is necessary, use Tool J-23062-110 and Drive Handle J-8092 and remove the bushing. See Figure 350C-181.

**Installation**

1. Install direct clutch bushing using Tool J-23062-14, Drive Handle J-8092, and install .010" below slot in retainer hub. See Figure 350C-182.

**Sun Gear Bushing**

**Removal**

1. If replacement of sun gear bushings is necessary, use Tool J-23062-13 and Drive Handle J-8092 and drive both bushings out through sun gear. See Figure 350C-183.

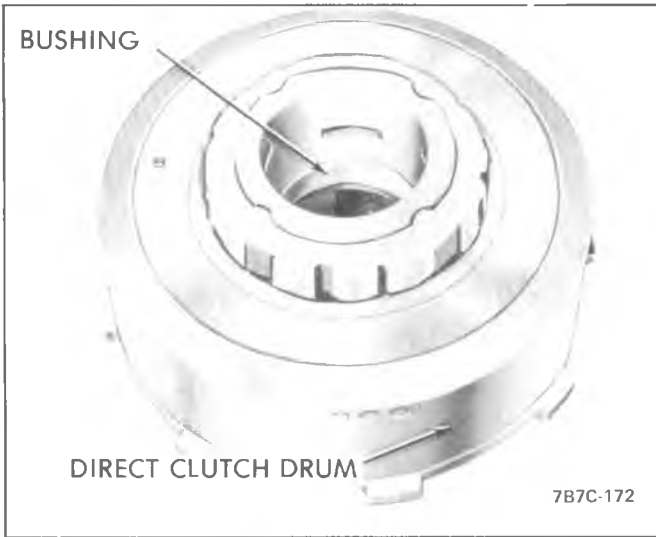

Figure 350C-181 Removing Direct Clutch Bushing

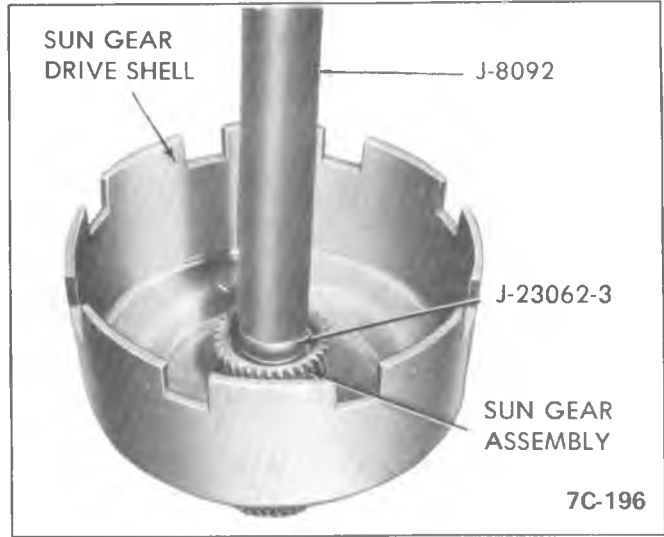

Figure 350C-183 Install Sun Gear Bushing

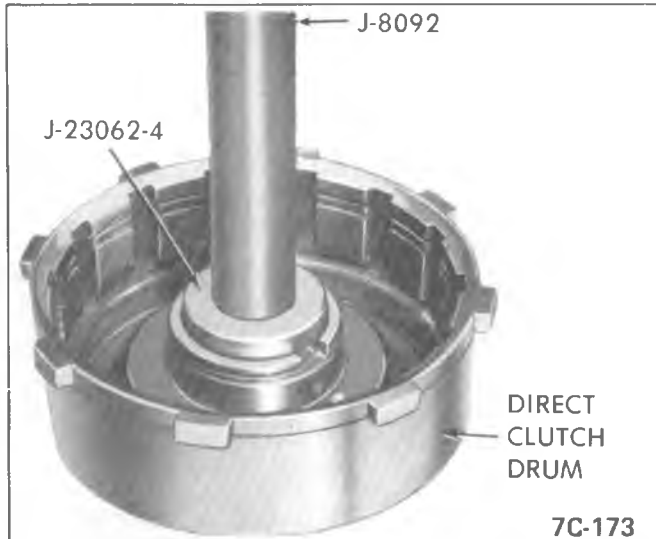

Figure 350C-182 Install Direct Clutch Bushing

#### Installation

1. Install sun gear bushings using Tool J-23062-13 and Drive Handle J-8092 and install flush to .010" below counter bores. See Figure 350C-183.

## TORQUE SPECIFICATIONS

| Location  | Thread   | Torque ft.lbs.       |
|---|----------|----------------------|
| Oil Pan to Transmission Case                            | 5/16-18  | 13                   |
| Pump Assembly to Transmission Case                      | 5/16-18  | 20                   |
| Vacuum Modulator Retainer to Case                       | 5/16-18  | 12                   |
| Valve Body Assembly to Case                             | 5/16-18  | 13                   |
| Oil Channel Support Plate to Case                       | 5/16-18  | 13                   |
| Pump Body to Pump Cover                                 | 5/16-18  | 15                   |
| Parking Lock Bracket to Case                            | 5/16-18  | 29                   |
| Extension Housing to Case                               | 3/8-16   | 35                   |
| Inside Shift Nut  | 3/8-16   | 30                   |
| External Test Plugs to Case                             | 1/8-27   | 8                    |
| Transmission Mount to Transmission                      | M10-1.5  | 48 N·m (35 ft. lbs.) |
| Speedo sleeve retainer on Extension Housing             | M6.0-1.0 | 17 N·m (150 lb. in.) |
| Detent Cable to Case Nut on End of Selector Lever Shaft | M6.0-1.0 | 8.5 N·m (75 lb. in.) |
|   | M10-1.5  | 27 N·m (20 ft. lbs.) |
| Converter to Flywheel                                   | M10-1.5  | 45 N·m (35 ft. lbs.) |

### 1983 AUTOMATIC 350C TRANSMISSION CLUTCH PLATE USAGE

| TRANS-<br>MISSION<br>I.D. CODE | SPEEDOMETER<br>DRIVE GEAR |               | INTERMEDIATE<br>CLUTCH    |                           |                               | DIRECT<br>CLUTCH          |                           |                              | FORWARD<br>CLUTCH         |                           |                              | LO & REVERSE<br>CLUTCH    |                           |                              |
|--------------------------------|---------------------------|---------------|---------------------------|---------------------------|-------------------------------|---------------------------|---------------------------|------------------------------|---------------------------|---------------------------|------------------------------|---------------------------|---------------------------|------------------------------|
|                                | Number<br>Of<br>Teeth     | Gear<br>Color | No. Of<br>Faced<br>Plates | No. Of<br>Steel<br>Plates | Clutch<br>Piston<br>Thickness | No. Of<br>Faced<br>Plates | No. Of<br>Steel<br>Plates | Clutch<br>Plate<br>Thickness | No. Of<br>Faced<br>Plates | No. Of<br>Steel<br>Plates | Clutch<br>Plate<br>Thickness | No. Of<br>Faced<br>Plates | No. Of<br>Steel<br>Plates | Clutch<br>Plate<br>Thickness |
| WD,WH                          | 10                        | Purple        | 3                         | 3                         | .992                          | 4                         | 4                         | .833                         | 4                         | 4                         | 1.405                        | 4                         | 4                         | 3.106                        |
| WE,WJ<br>V4                    | 9                         | Green         | 3                         | 3                         | .992                          | 4                         | 4                         | .833                         | 5                         | 5                         | 1.223                        | 5                         | 5                         | 2.921                        |
| KA,KC<br>KE,KN                 | 17                        | Red           | 2                         | 2                         | 1.184                         | 3                         | 3                         | 1.014                        | 4                         | 4                         | 1.391                        | 4                         | 4                         | 3.106                        |
| LD,LB                          | 19                        | Yellow        | 3                         | 3                         | .992                          | 4                         | 4                         | .833                         | 5                         | 5                         | 1.221                        | 5                         | 5                         | 2.921                        |

H 350C-100A

Figure 350C-185

ESSENTIAL TOOLS — THM350C & THM250C











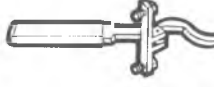
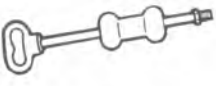









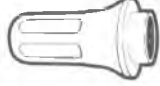

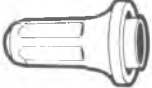
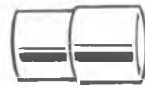
|   |  |   |   |
|---|--|---|---|
|    | J 2590-02<br>Clutch Spring Compressor                        |    | J 23069<br>Accumulator Cover Remover & Installer  |
|    | J 2619-A<br>Slide Hammer (5/8" x 18" with 1/2" x 13 Adapter) |    | J 26744<br>Piston Seal Installer  |
|    | J 8763-02<br>Holding Fixture (Use with J3289-20)             |    | J 22974<br>Seal Protector   |
|    | J 3289-20<br>Holding Fixture Base (Use with J 8763-02)       |    | J 23327<br>Clutch Spring Compressor   |
|    | J 7004-1<br>Slide Hammers-Pair (3/4" x 16 Thread)            |    | J 22269-01<br>Servo Remover-THM250 Direct Clutch Accumulator Remover & Installer              |
|    | J 8092<br>Driver Handle                                      |    | J 24367<br>Band Adjuster-THM250C  |
|  | J 21359<br>Oil Pump Seal Installer                           |  | J 23062-01<br>Bushing Service Tool Set (use with J 8092)                                      |
|  | J 21426<br>Extension Housing Seal Installer                  |  | J 21424-7<br>Stator Shaft Bushing Installer (Front) (use with J 8098)                         |
|  | J 21366<br>Converter Holding Strap                           |  | J 21424-9<br>Extension Housing Bushing Remover & Installer (use with J 8098)                  |
|  | J 21369-B<br>Converter Leak Test Fixture                     |  | J 22976<br>Governor Bore Bushing Installation Tool Set (use with J 8092)                      |
|  | J 23134<br>Pump Check Valve Seat Remover                     |  | J 21465-13<br>Driver Handle Extension (J 8092)  |
|  | J 23112<br>Pump Check Valve Seat Remover                     |  | J 21465-15<br>Stator Shaft Bushing Remover (J 8092)   |
|  | J 24466<br>Modulator Checking Tool                           |  | J 21465-17<br>Converter Hub & Extension Housing Bushing Remover & Installer (Use with J 8092) |
|  | J 26507<br>Low & Reverse Clutch Support Remover              |  | J 9534-01<br>Output Shaft Bushing Remover   |

Figure 350C-189 Special Tools

## SECTION 400

## 400 AUTOMATIC TRANSMISSION

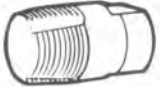
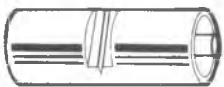
## GENERAL DESCRIPTION

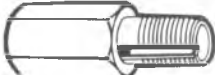
The 400 Series transmission is a fully automatic unit consisting primarily of a 3-element hydraulic torque converter and a compound planetary gear set. Three multiple-disc clutches, two roller clutch units, and two bands provide the friction elements required to obtain the desired functions of the compound planetary gear set, **Figure 400-1** and **Figure 400-2**.

The torque converter, the clutches, and roller clutches, couple the engine to the planetary gears through oil pressure, providing three forward speeds and reverse. The torque converter, when required, will supplement the gears by multiplying engine torque.

The torque converter is of welded construction and is serviced as an assembly. The unit is made up of two vaned sections, or halves, that face each other in an oil filled housing. The pump half of the converter is connected to the engine and the turbine half is connected to the transmission.

When the engine makes the converter pump revolve, it sends oil against the turbine, making it revolve also. The oil then returns in a circular flow back to the converter pump, continuing this flow as long as the engine is running.

The converter also has a smaller vaned section, called a stator, that funnels the oil back to the converter pump through smaller openings, at increased speed. The speeded up oil directs additional force to the engine-driven converter pump, thereby multiplying engine torque.

A hydraulic system pressurized by an internal-external type gear pump provides the working pressure required to operate the friction elements and automatic controls.

External control connections to the transmission are:

**Manual Linkage** - To select the desired operating range.

**Engine Vacuum** - To operate a vacuum modulator unit.

**12 Volt Electrical Signals** - To operate an electrical detent solenoid.

Gear or torque ratios of the transmission are as follows:

First = 2.48:1 gear ratio

Second = 1.48:1 gear ratio

Third = 1.0:1 gear ratio

Reverse = 2.08:1 gear ratio

Each gear ratio can be multiplied by as much as 2, depending upon the slip speed of the converter pump and turbine.

A vacuum modulator is used to sense engine torque input to the transmission automatically. The vacuum modulator transmits this signal to the pressure regulator, which controls line pressure, so that all torque requirements of the transmission are met and proper shift spacing is obtained at all throttle openings.

The detent solenoid is activated by a switch at the carburetor. When the throttle is opened sufficiently to close this switch, the solenoid in the transmission is activated, causing a downshift at speeds below approximately 110

Km/h (70 mph). At lower speeds, downshifts will occur at lesser throttle openings without use of the switch.

The oil cooler is located in the right hand tank of the radiator. The transmission is cooled by directing oil from the converter to the radiator. Oil returning from the radiator feeds the transmission lubrication system.

The oil system incorporates an intake pipe and filter assembly. The filter assembly should be replaced after 160,000 Km (100,000 miles) of use under normal operating conditions. It should be replaced after the first 80,000 Km (50,000 miles) if heavy duty operation is encountered, such as constant use in heavy metropolitan traffic, pulling trailers, etc. In addition, replace filter assembly when a major transmission failure occurs and flush the oil cooler and cooler lines. This is particularly important in the case of a converter failure.

The transmission quadrant has six selector positions, that enable the driver to control the operation of the transmission under various driving conditions. The six selector positions appear on the quadrant in the following sequence, from left to right; P-park, R-reverse, N-neutral, DRIVE left, DRIVE right (intermediate) and L-lo.

**P** - Park position positively locks the output shaft to the transmission case by means of a locking pawl and prevents the vehicle from rolling either forward or backward. For this reason, it is recommended that the engine be started with transmission selector lever in **Park** position. If it is necessary to re-start the engine with the car rolling, place selector lever in **Neutral**.

**R** - Reverse enables the vehicle to be operated in a reverse direction.

**N** - Neutral position enables the engine to be started and run without driving the vehicle. It is recommended that **Neutral** be used to start the engine only if it is necessary to re-start the engine with the car rolling. At all other times **Park** should be used.

**Drive (left)** - is used for all normal driving conditions and maximum economy. **Drive (left)** has three gear ratios from starting to direct drive. Downshifts are available for safe passing, by depressing the accelerator pedal.

**Drive (right)** - adds performance for congested traffic or hilly terrain. This range has the same starting ratio as **Drive (left)**, but prevents the transmission from shifting above second speed to retain acceleration when extra performance is desired. Engine braking is provided in this range.

**L** - Lo range permits operation at the lowest ratio, and should be used where only the lowest gear ratio is desired, such as in pulling a heavy load or descending a steep grade. When selector lever is moved from **Drive** to **Lo** range at normal highway speeds, the transmission will shift to second gear and remain in second gear until vehicle speed is reduced to approximately 45 mph. The transmission will then shift

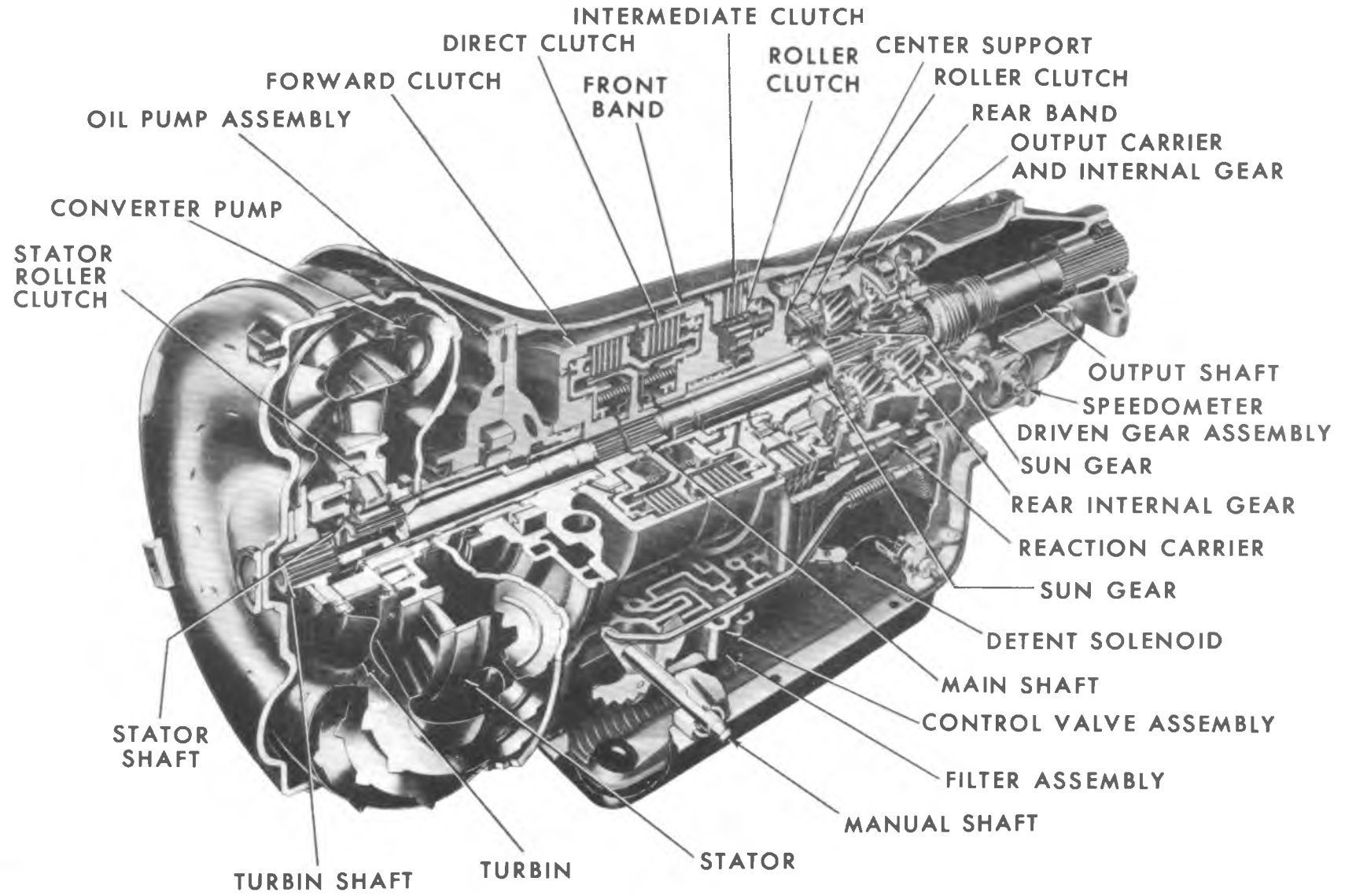
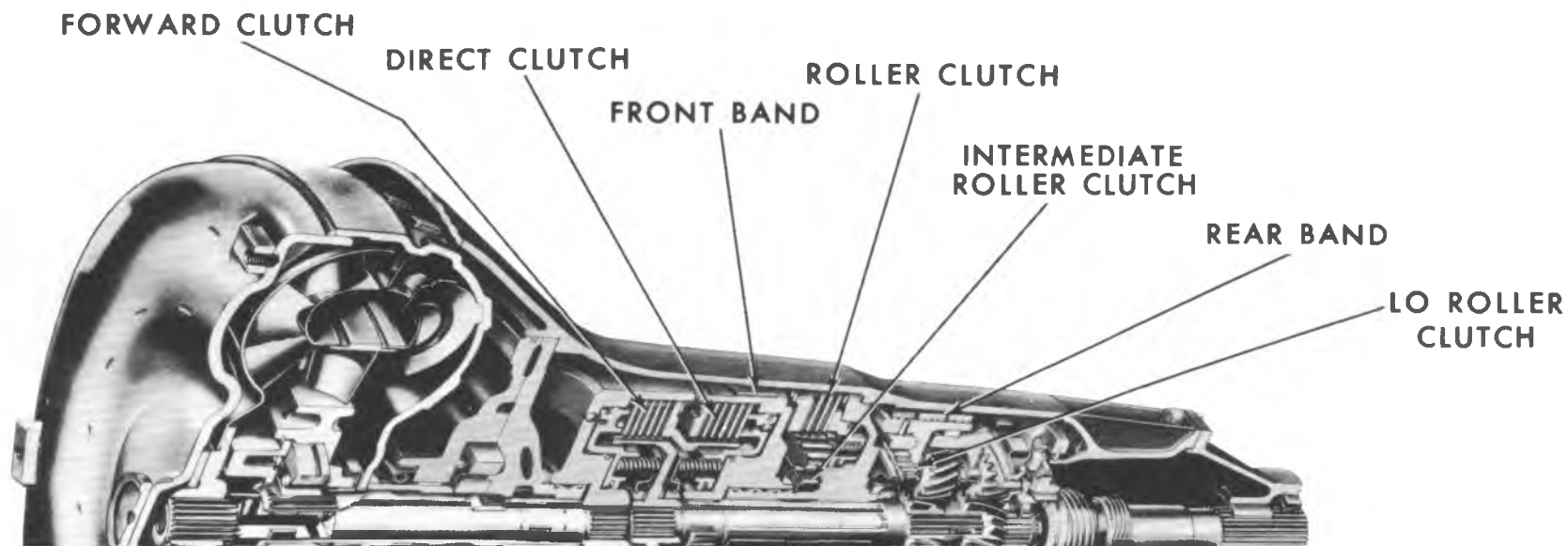

Figure 400-1 400 Transmission - Cutaway View

Figure 400-2 Band, Roller Clutch and Clutch Application Chart



| RANGE      | GEAR   | FORWARD CLUTCH | DIRECT CLUTCH | FRONT BAND | INT. CLUTCH | INT. ROLLER CLUTCH | LO ROLLER CLUTCH | REAR BAND |
|------------|--------|----------------|---------------|------------|-------------|--------------------|------------------|-----------|
| PARK-NEUT. |        | OFF            | OFF           | OFF        | OFF         | INEFFECTIVE        | INEFFECTIVE      | OFF       |
| DRIVE      | FIRST  | ON             | OFF           | OFF        | OFF         | INEFFECTIVE        | EFFECTIVE        | OFF       |
|            | SECOND | ON             | OFF           | OFF        | ON          | EFFECTIVE          | INEFFECTIVE      | OFF       |
|            | THIRD  | ON             | ON            | OFF        | ON          | INEFFECTIVE        | INEFFECTIVE      | OFF       |
| INT.       | FIRST  | ON             | OFF           | OFF        | OFF         | INEFFECTIVE        | EFFECTIVE        | OFF       |
|            | SECOND | ON             | OFF           | ON         | ON          | EFFECTIVE          | INEFFECTIVE      | OFF       |
| LO         | FIRST  | ON             | OFF           | OFF        | OFF         | INEFFECTIVE        | EFFECTIVE        | ON        |
|            | SECOND | ON             | OFF           | ON         | ON          | EFFECTIVE          | INEFFECTIVE      | OFF       |
| REV.       |        | OFF            | ON            | OFF        | OFF         | INEFFECTIVE        | INEFFECTIVE      | ON        |



## 4 TRANSMISSION - 400

to first gear and remain in first gear regardless of vehicle or engine speed, until selector lever is moved back into either of the Drive positions.

1981 transmission models and their applications are listed in **Figure 400-3**.

| MODEL                                     | CALIBRATION  | AXLE RATIO  | TRANS. MOD./TYPE |
|---|--------------|-------------|------------------|
| DEVILLE<br>AND<br>BROUGHAM                | FED. CARB.   | 2.28:1 STD. | AE/400           |
|   |              | 2.73:1 TTP  | AD/400           |
|   | CALIF. CARB. | 2.56:1 STD. | AB/400           |
|   | DIESEL       | 2.41:1 STD. | AS-AX/200 C      |
| LIMOUSINE<br>AND<br>COMMERCIAL<br>CHASSIS | ALL          | 3.08:1 STD. | AD/400           |

Figure400-3 Transmission Usage Chart

## DIAGNOSIS

### 400 AUTOMATIC TRANSMISSION PROCEDURE

**NOTICE:** In the event of a major transmission malfunction, replace filter assembly, flush oil cooler and lines before installing new fluid. This is particularly important in the case of a converter or pump malfunction.

This Diagnosis Guide should be used in the following sequence to positively locate the problem:

1. Perform the "Preliminary Checking Procedure", in **Figure 400-5** recording the readings in the Oil Pressure Reading row. After taking the pressure readings, place Low, Normal or High in each box of the Oil Pressure Pattern row.

2. Road test the car as described in Part B if problem is not known.

3. Refer to the "Transmission Malfunction Related to Oil Pressure" chart, in **Figure 400-7**. First determine if malfunction noted is in this chart. If so, compare Oil Pressure Pattern row, **Figure 400-5** and **Figure 400-7**. A dash on the "Transmission Malfunction Related to Oil Pressure" chart means that the oil pressure reading has no significance under the test condition.

If transmission malfunction is found in this chart, follow the directions indicated in the Malfunction column. The oil pressure pattern will indicate where the malfunction is.

The only time it is necessary to determine a pressure drop (the control valve assembly-governor line pressure check, part b) is when there is "No 1-2 Upshift and/or Delayed Upshift" and all oil pressure readings are normal.

It will not be necessary to repeat oil pressure readings taken during preliminary checks should this be called for during further tests.

4. If malfunction cannot be determined by the chart, **Figure 400-7**, or if upon completion of these tests, it is not found, see the "Transmission Troubleshooting Guide", starting with Part C to locate malfunction not related to oil pressure.

All malfunctions, both those related to oil pressure and those that are not, are listed in the "Transmission

| 400 SERIES TRANSMISSION |           |
|-------------------------|-----------|
| UPSHIFT                 | MINIMUM   |
| 1-2                     | 15 MPH    |
| 2-3                     | 30 MPH    |
| UPSHIFT                 | MAXIMUM   |
| 1-2                     | 44-48 MPH |
| 2-3                     | 77-83 MPH |
| DETENT DOWNSHIFT        | MINIMUM   |
| 3-2                     | 68-73 MPH |
| 2-1                     | 28-32 MPH |

Figure400-4 Shift Point Specifications

Troubleshooting Guide". Always perform the "Preliminary Checking Procedure" first as it provides a positive means to isolate the problem if the malfunction can be diagnosed by this procedure.

5. After correcting malfunction, road test car as described in Part B Transmission Road Testing.

#### A. Preliminary Checking Procedure

Perform checking procedure shown in **Figure 400-5**.

#### B. Transmission Road Testing

##### Refer to Figure400-4

1. Connect portable tachometer to engine. Engine rpm will identify shift points.

2. Place selector in "Drive Left" position and accelerate the vehicle from rest at a minimum throttle opening. The specifications for shift points are:

Downshifts should occur (3-2 and 2-1) as the vehicle speed decreases to 0 mph. Stop car.

3. Place selector in "Drive Right" position and accelerate the vehicle from rest. A 1-2 shift should occur at

all throttle openings. No 2-3 shift can be obtained in this range. Stop car.

4. Place selector in "Low". No upshift should occur in this range regardless of the throttle opening.

5. Position the selector in "Drive Left" and accelerate the vehicle to 35 mph and move the selector to "Drive Right". A 3-2 downshift should occur, increasing the engine rpm and an engine braking effect should be noticed on deceleration.

6. With the selector in "Drive Right" at approximately 25 mph, but not over 40 mph, at closed throttle, move the selector to "Low". A 2-1 downshift should occur, increasing the engine rpm and an engine braking effect should be noticed on deceleration. Stop car.

7. Place selector in "Reverse" and check for reverse operation.

### E.G.R. SYSTEM

With Exhaust Gas Recirculation (EGR), the throttle is open enough in "Drive" range (1000 rpm) to cause the EGR valve to open. When the EGR valve opens, exhaust gas enters the intake manifold which lowers intake manifold vacuum. When intake manifold vacuum is lowered, the transmission line oil pressure raises accordingly, and may go above the upper specification limit. For this reason, if high line pressures are obtained, proceed as follows:

1. Disconnect the EGR vacuum line at the EGR valve and plug the vacuum line.

2. Recheck line pressures as indicated on the Preliminary Checking Procedure Chart, **Figure 400-5**.

3. If high line pressures are still obtained, it may be that the engine is not producing enough vacuum to lower transmission line pressure within specifications. The newer engines with emission controls characteristically have lower engine vacuum than older past model engines. To obtain line pressures suitable for evaluation, it is recommended that vacuum be applied to the modulator, using an external vacuum source such as J-23738 hand operated vacuum device or its equivalent. The unit allows definite amounts of vacuum to be applied to the modulator so that consistent line pressures may be obtained for evaluation as follows:

1. Disconnect the vacuum hose to the modulator at the modulator and plug the vacuum hose.

2. Attach the hand operated vacuum device and apply 20" of vacuum.

3. Recheck line pressures according to the Preliminary Checking Procedure Chart, **Figure 400-5**.

4. If line pressures are still high, proceed to the specific diagnosis chart that applies to the malfunction encountered.

5. If line pressures are normal with external vacuum applied, check engine vacuum and vacuum systems for leaks.

### C. Cause of Low Line Pressure

1. Low Transmission Oil Level.
2. Modulator Assembly see Part V.
3. Filter.

A. Blocked or restricted.\*

B. "O" Ring on intake pipe and/or grommet omitted or damaged.

C. Split or leaking intake pipe.

D. Wrong filter assembly.

4. Pump.

A. Pressure regulator or boost valve stuck.

B. Gear clearance, damaged worn. (Pump will become damaged if drive gear is installed backwards, or if converter pilot does not enter crankshaft freely).

C. Pressure regulator spring, too weak.

D. Not enough spacers in pressure regulator.

E. Pump to case gasket mispositioned.

F. Malfunctioning pump body and/or cover.

G. Mismatch pump cover/pump body.

5. Internal Circuit Leaks.

A. Forward clutch leak (pressure normal in neutral and reverse-pressure low in drive).

1. Check pump rings.

2. Check forward clutch seals.

B. Direct clutch leak (pressure normal in neutral, low, intermediate, and drive-pressure low in reverse).

1. Check center support oil seal rings.

2. Check direct clutch outer seal for damage.

3. Check rear servo and front accumulator pistons and rings for damage or missing.

6. Case Assembly.

A. Porosity in intake bore area.

B. Check case for intermediate clutch plug leak or missing plug.

C. Lo-reverse check ball mispositioned or missing (this will cause no reverse and no overrun braking in Lo range).

\*There is no approved service procedure for checking or cleaning the filter, if the filter is suspected of being plugged or restricted. It must be replaced.

### D. Causes of High Line Pressure

1. Vacuum Leak

A. Full leak (vacuum line disconnected.)

B. Partial leak in line from engine modulator.

C. Improper engine vacuum.

D. Vacuum operated accessory leak. (Hoses, vacuum advance, etc.).

2. Damaged Modulator.

A. Stuck valve.

B. Water in modulator.

C. Not operating properly - Part V.

3. Detent System.

A. Detent switch actuated (plunger stuck) or shorted.

B. Detent wiring shorted.

C. Detent solenoid stuck open.

D. Detent feed orifice in spacer plate blocked.

E. Detent solenoid loose.

F. Detent valve bore plug damaged.

G. Detent regulator valve pin short.

4. Pump.

A. Pressure regulator and/or boost valve stuck.

B. Incorrect pressure regulator spring.

C. Too many pressure regulator valve spacers.

D. Pump casting bad.

E. Pressure boost valve installed backwards or malfunctioning.

## DIAGNOSIS

### PRELIMINARY CHECKING PROCEDURE

CHECK TRANS. OIL LEVEL  
(See Page 400-26.)

CHECK OUTSIDE MANUAL LINKAGE AND CORRECT (See Page 400-24.)

CHECK ENGINE TIMING AND IDLE (See Section 6-C & 6-D.)

**CAUTION: TOTAL RUNNING TIME FOR THIS COMBINATION NOT TO EXCEED 2 MINUTES.**

INSTALL OIL PRESSURE GAGE(See Fig.400-3)

CONNECT TACHOMETER TO ENGINE

#### CHECK OIL PRESSURES IN FOLLOWING MANNER

|          | RANGE   | OIL PRESSURE READING | NORMAL P.S.I.          | OIL PRESSURE PATTERN LOW-NORMAL-HIGH |
|----------|---|----------------------|------------------------|--------------------------------------|
| <b>1</b> | NEUTRAL-BRAKES APPLIED<br>ENGINE AT 1000 RPM                                  |                      | 55 TO 70               |                                      |
| <b>2</b> | DRIVE IDLE<br>SET ENGINE IDLE TO SPECIFICATIONS                               |                      | 60 TO 85               |                                      |
| <b>3</b> | DRIVE LEFT-BRAKES APPLIED<br>ENGINE AT 1000 RPM                               |                      | 60 TO 90*              | }                                    |
| <b>4</b> | DRIVE RIGHT OR LO-BRAKES APPLIED<br>ENGINE AT 1000 RPM                        |                      | 135 TO 160*            |                                      |
| <b>5</b> | REVERSE-BRAKES APPLIED<br>ENGINE AT 1000 RPM                                  |                      | 95 TO 150*             |                                      |
| <b>6</b> | DRIVE LEFT-BRAKES APPLIED<br>ENGINE AT 1000 RPM<br>DOWNSHIFT SWITCH ACTIVATED |                      | 90 TO 110              |                                      |
| <b>7</b> | GOVERNOR CHECK-FOR UPSHIFT PROBLEM SEE PROCEDURE, Page 400-3                  |                      | DROP OF 10 PSI OR MORE |                                      |
| <b>8</b> | DRIVE - 30 MPH - CLOSED THROTTLE ON ROAD, OR ON HOIST**                       |                      | 55 TO 70               |                                      |

\* IF HIGH LINE PRESSURES ARE EXPERIENCED, SEE PAGE 400-7

\*\* VEHICLE ON HOIST, DRIVING WHEELS OFF GROUND, SELECTOR IN DRIVE, BRAKES RELEASED, RAISE ENGINE TO 3000 R.P.M., CLOSE THROTTLE AND READ PRESSURE BETWEEN 2000 AND 1200 R.P.M.

Figure400-5 Preliminary Checking Procedure



Figure 400-6 Oil Pressure Test Gage

F. Aluminum bore plug has hole or otherwise malfunctioning.

G. Pressure boost bushing broken or otherwise malfunctioning.

5. Control Valve Assembly.

A. Spacer plate-to-case gasket off location.

B. Wrong spacer plate-to-case gasket,

### E. Causes of Oil Leaks

1. Transmission Oil Pan Leaks.

A. Attaching screws not correctly torqued.

B. Improperly installed or damaged pan gasket.

C. Oil pan gasket mounting face not flat.

2. Case Extension Leak.

A. Attaching screws not correctly torqued.

B. Rear seal assembly - damaged or improperly installed. (Propeller shaft yoke damaged).

C. Gasket - (Extension to case) damaged or improperly installed.

D. Porous casting.

E. Output shaft "O" ring damaged.

3. Case Leak.

A. Filler pipe "O" ring seal damaged or missing; misposition of filler pipe bracket to engine "Loading" one side of the "O" ring.

B. Modulator assembly "O" ring seal damaged or improperly installed.

C. Connector "O" ring seal damaged or improperly installed.

D. Governor cover, gasket and screws - damaged, loose; case face leak.

E. Damaged or porosity. Leak at speedometer driven gear housing or seal. Leak at speedometer hole plug.

F. Manual shaft seal - damaged, improperly installed.

G. Line pressure tap plug - stripped, lacking compound.

H. Vent pipe (refer to Item 5 below).

I. Porous case, or cracked at pressure plug boss.

4. Front End Leak.

A. Front seal - damaged (check converter neck for nicks, etc., also for pump bushing moved forward) garter spring missing.

B. Pump attaching screws, and seals - damaged, missing, screws loose.

C. Converter - leak in weld.

D. Pump "O" ring seal - damaged. (Also check pump oil ring groove and case bore).

E. Porous casting (pump or case).

F. Pump - drain back hole not open.

5. Oil Comes Out Vent Pipe.

A. Transmission over-filled.

B. Water in oil.

C. Filter "O" ring damaged or improperly assembled causing oil to foam.

D. Foreign material between pump and case or between pump cover and body.

E. Case - porous, pump face improperly machined.

F. Pump - insufficient metal, porous.

G. Pump to case gasket mispositioned.

H. Pump breather hole blocked or missing.

I. Hole in intake pipe.

6. Oil Cooler Lines.

A. Connections at radiator loose or stripped.

B. Connections at case loose or stripped.

7. Modulator Assembly. Diaphragm leaking - Part V.

### F. Control Valve Assembly - Governor Line Pressure Check

1. Install oil pressure test gage, **Figure 400-6**.

2. Install tachometer.

3. Disconnect vacuum line to modulator.

4. With vehicle on hoist (driving wheels off ground), foot off brake, in drive, check line pressure at 1000 rpm.

5. Slowly increase engine rpm to 3000 rpm and determine if a line pressure drop occurs (10 psi or more).

6. If pressure drop of 10 psi or more occurs, disassemble, clean and inspect control valve assembly.

7. If pressure drop is less than 10 psi:

a. Inspect governor

1. Stuck valve.

2. Weight Freeness.

3. Restricted orifice in governor valve.

4. Check governor valve entry and exhaust (.020" min.). For procedure, refer to current service manual.

b. Governor feed system

1. Check screen in control valve assembly or case.

2. Check for restrictions in governor pipe.

3. Check for fit of governor pipes in case holes.

### U. Downshift Solenoid Circuit Check

Before checking the downshift solenoid circuitry, make certain that the transmission downshift switch is properly adjusted.

1. With transmission shift lever in Park, turn ignition switch to "ON" position, but do not start car. Leave ignition switch "ON" throughout checking procedure.

2. Working under hood, slowly advance throttle linkage to wide open position. One click should be heard from transmission.

8 TRANSMISSION - 400

|   | 1                               | 2             | 3                                    | 4                               | 5                               | 6   | 7   | 8                            |   |
|---|---------------------------------|---------------|--------------------------------------|---------------------------------|---------------------------------|---|---|------------------------------|---|
| Malfunction   | Neutral Brakes Applied 1000 rpm | Drive Idle    | Drive Left — Brakes Applied 1000 rpm | Drive-R Brakes Applied 1000 rpm | Reverse Brakes Applied 1000 rpm | Drive Left — Brakes Applied 1000 rpm Downshift Switch Activated | Pressure Drop Occurs while Engine rpm Increases from 1000 to 3000 rpm<br>Wheels Free to Move* | Drive 30 mph Closed Throttle | Possible Cause of Malfunction                               |
|   | Oil Pressure                    | Oil Pressure  | Oil Pressure                         | Oil Pressure                    | Oil Pressure                    | Oil Pressure  |   | Oil Pressure                 |   |
| No 1-2 Upshift and/or Delayed Upshift   | Normal                          | Normal        | Normal                               | Normal                          | Normal                          | Normal  | 10 psi Drop or More   | Normal                       | Malfunction in Control Valve Assembly                       |
|   | Normal                          | Normal        | Normal                               | Normal                          | Normal                          | Normal  | Less than 10 psi Drop   | Normal                       | Malfunction in Governor or Governor Feed System             |
|   | Normal                          | High          | High                                 | Normal                          | Normal                          | Normal  |   | High                         | Malfunction in Detent System                                |
|   | High                            | High          | High                                 | Normal                          | High                            | —   | —   | —                            | Malfunction in Modulator or Vacuum Feed System to Modulator |
| Slipping-Reverse  | Normal                          | Normal        | Normal                               | Normal                          | Low                             | Normal  |   | Normal                       | Oil Leak in Feed System to the Direct Clutch                |
| Slipping-1st Gear   | Normal                          | Low to Normal | Low to Normal                        | Low to Normal                   | Normal                          | Low to Normal   | —   | Low to Normal                | Oil Leak in Feed System to the Forward Clutch               |
| Downshift with Zero Throttle and No Engine Braking in Drive   | Normal                          | High          | Normal                               | Normal                          | Normal                          | —   | —   | High                         | Stator and Detent Wires Switched                            |
| No Detent Downshifts  | Normal                          | Normal        | Normal                               | Normal                          | Normal                          | Low   |   | Normal                       | Malfunction in Detent System                                |
| <p>*Drive range, vacuum line disconnected from modulator.<br/>                     A dash (—) in the above chart means that the oil pressure reading has no meaning under the test condition.<br/>                     Pressures obtained by the Preliminary Checking procedure</p> |                                 |               |                                      |                                 |                                 |   |   |                              |   |

Figure400-7 Preliminary Diagnosis Procedure

H. NO. 1-2 UPSHIFT AND/OR DELAYED UPSHIFT

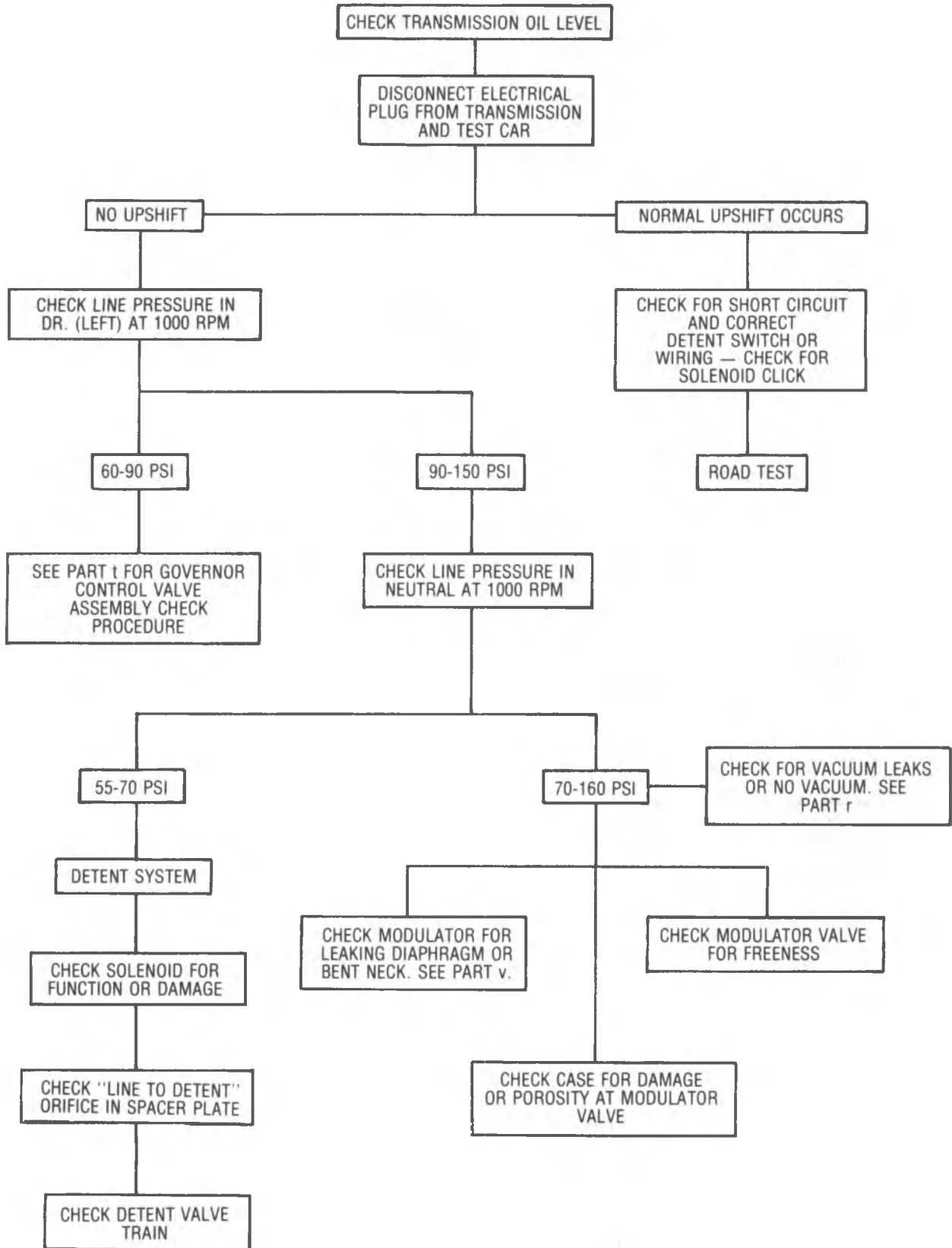

Figure400-8 Diagnosis

I. 1-2 SHIFT FEEL COMPLAINT — FIRM SHIFT

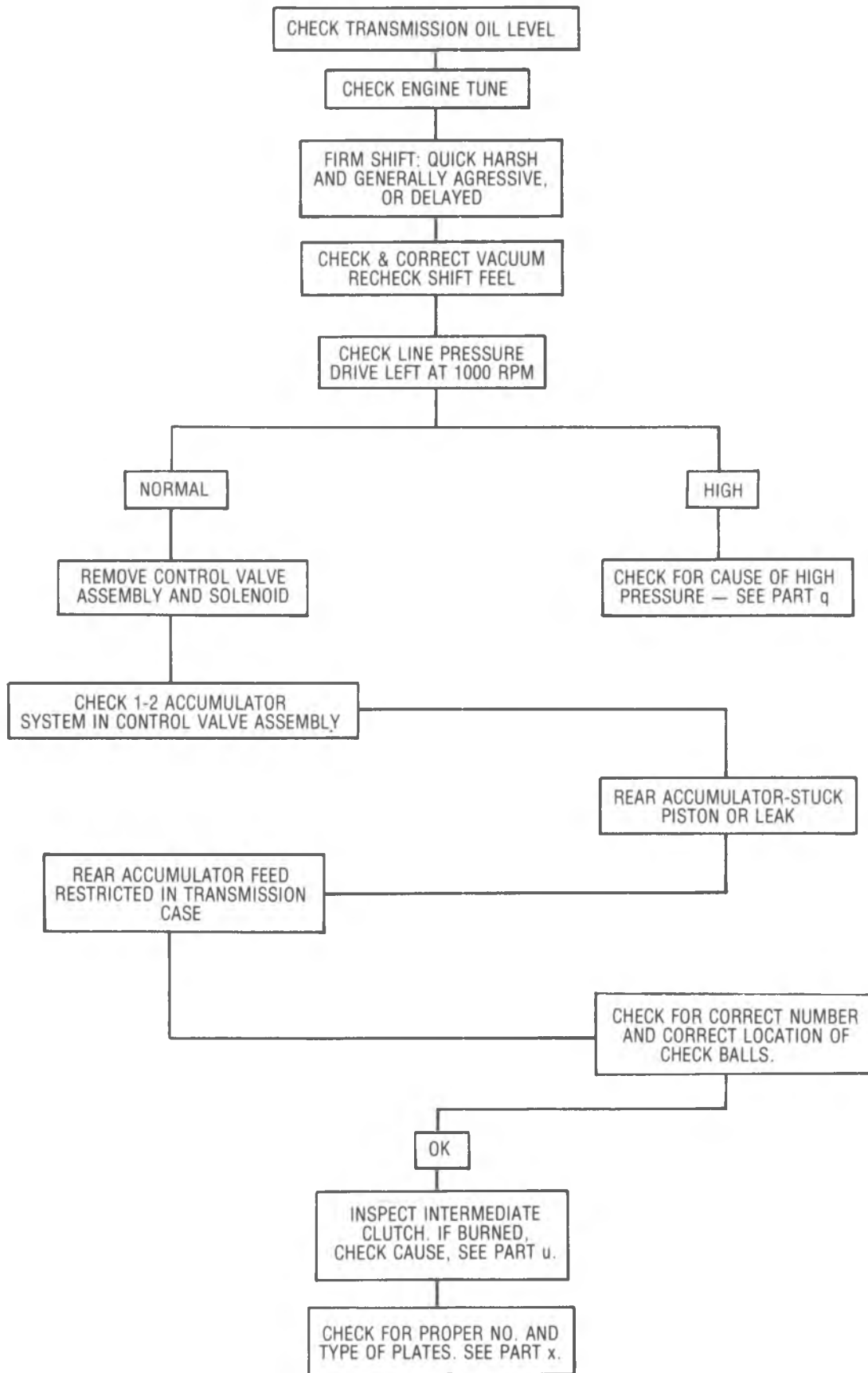

Figure400-9 Diagnosis

J. 1-2 SHIFT FEEL COMPLAINT — SOFT SHIFT

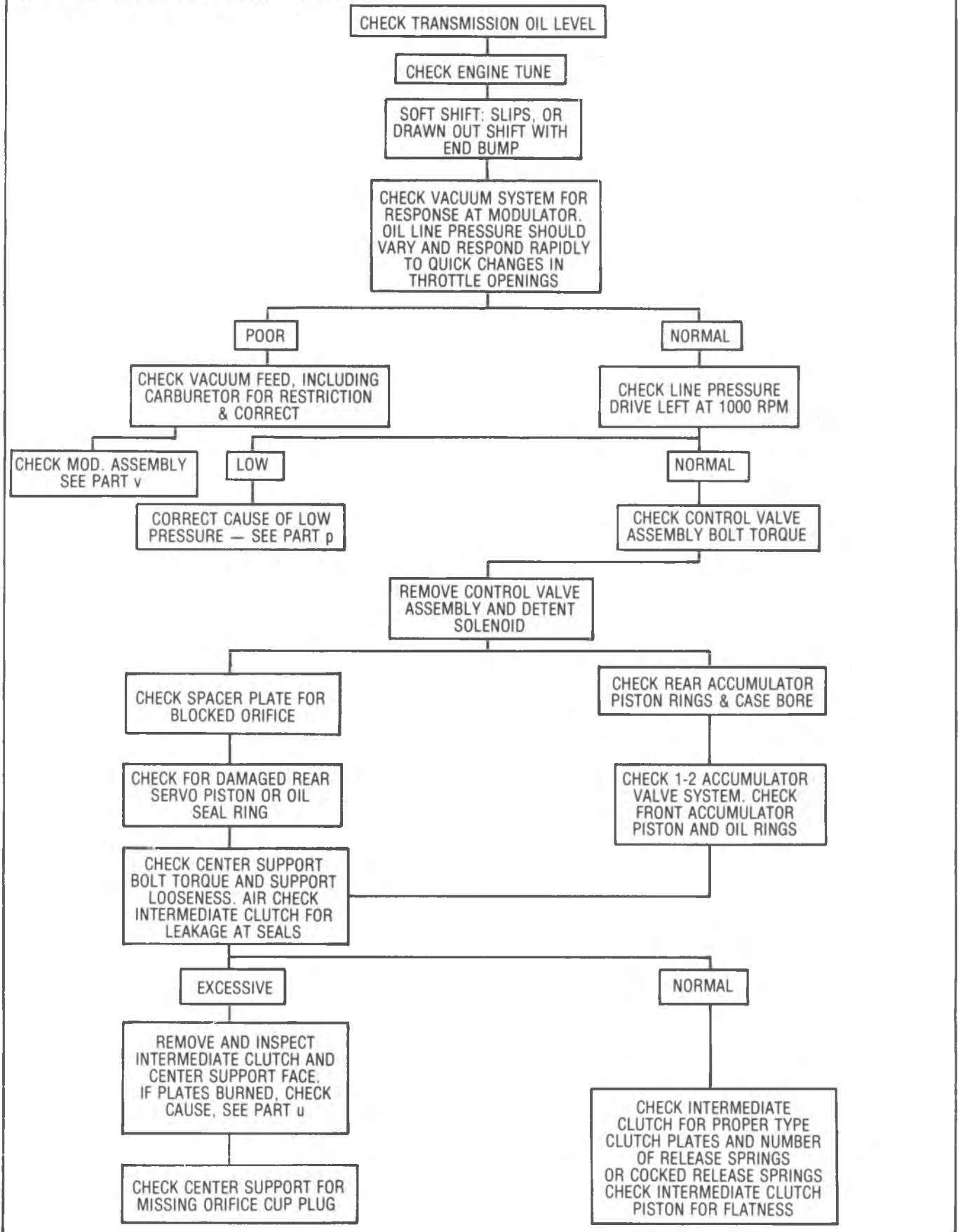

Figure 400-10 Diagnosis



K. 2-3 Shift Complaint

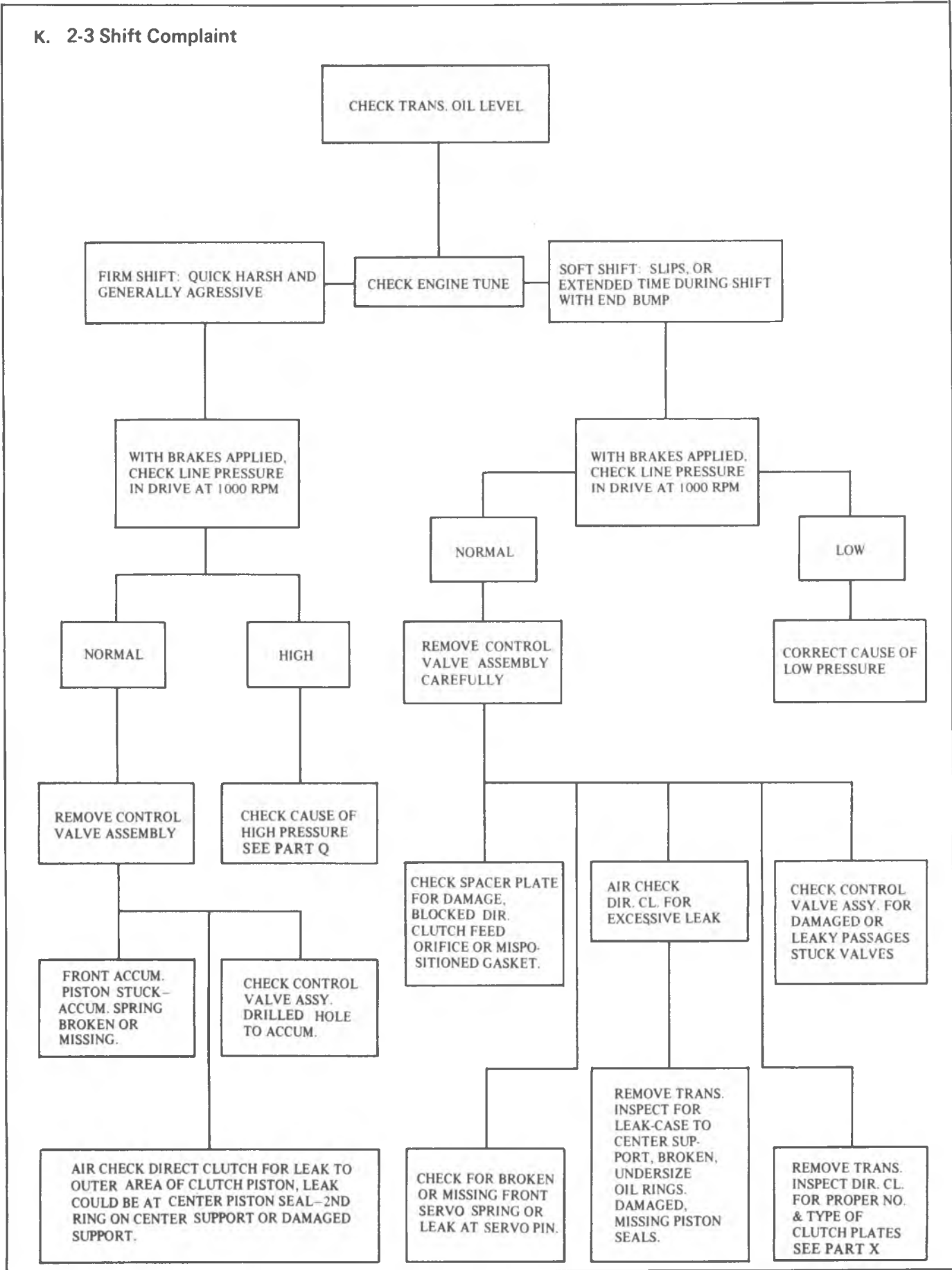

Figure 400-11 Diagnosis

## L. Drive in Neutral

CHECK OUTSIDE MANUAL LINKAGE & CORRECT

- INTERNAL LINKAGE -  
MANUAL VALVE DISCONNECTED OR END BROKEN,  
INSIDE DETENT LEVER PIN BROKEN

- PUMP ASSEMBLY -  
TRANSMISSION FLUID PRESSURE LEAKING INTO  
FORWARD CLUTCH APPLY PASSAGE

- FORWARD CLUTCH -  
BURNED PLATES - CHECK CAUSE - PART u  
INCORRECT CLUTCH PLATE USAGE - PART x

M. Will not Hold in Park or Will Not Release  
from Park

CHECK OUTSIDE MANUAL LINKAGE & CORRECT, PAGE 400-24

- INTERNAL LINKAGE -

1. Parking brake rod assembly (Check actuator for chamfer)
2. Parking pawl broken, chamfer omitted.
3. Parking brake bracket loose, burr or rough edges or incorrectly installed.
4. Parking pawl return spring missing, broken, incorrectly hooked.
5. Broken lugs on output carrier.

Figure 400-12 Diagnosis

N. No Engine Braking—Lo Range—1st Gear

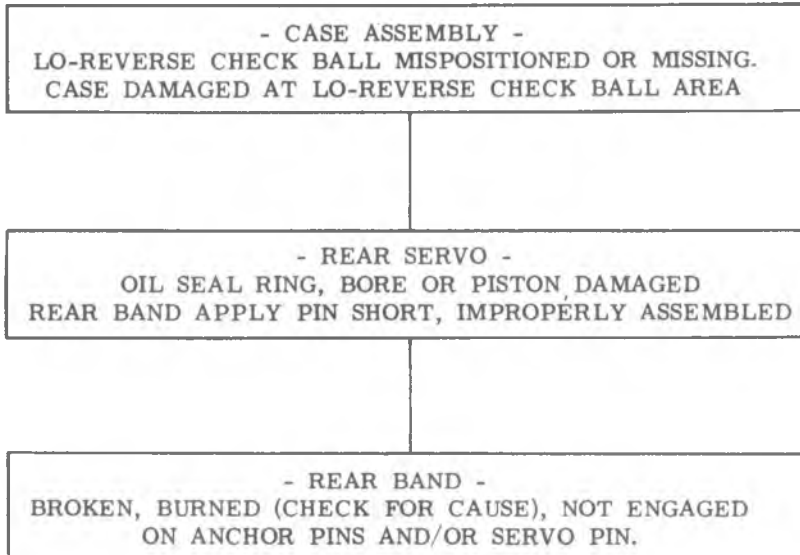

O. No Engine Braking—Intermediate Range—  
2nd Gear

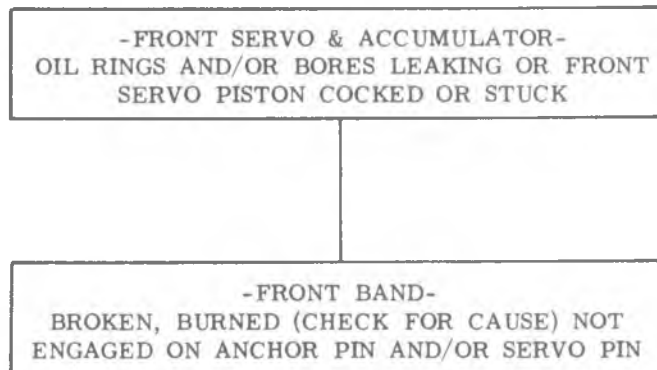

Figure 400-13 Diagnosis

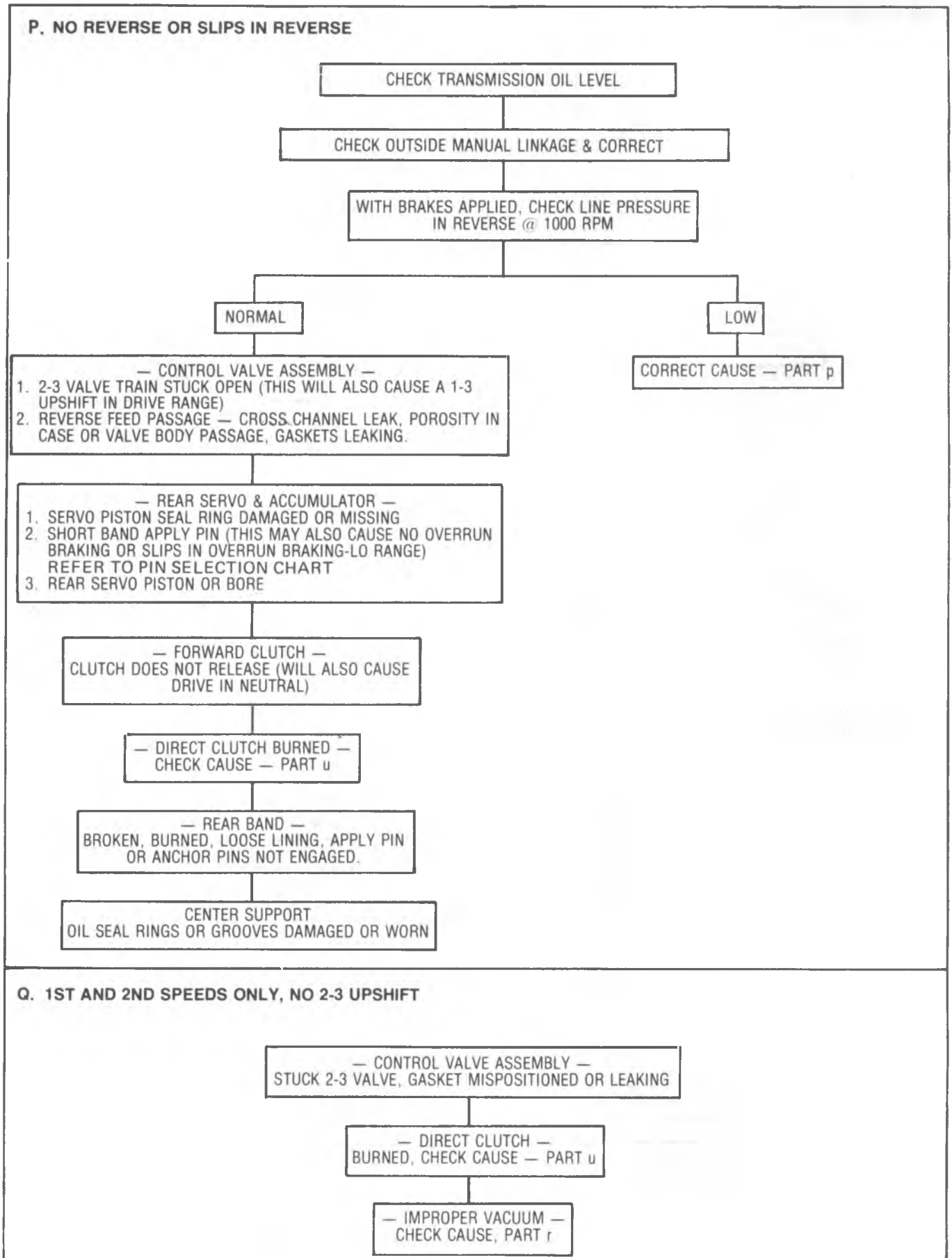
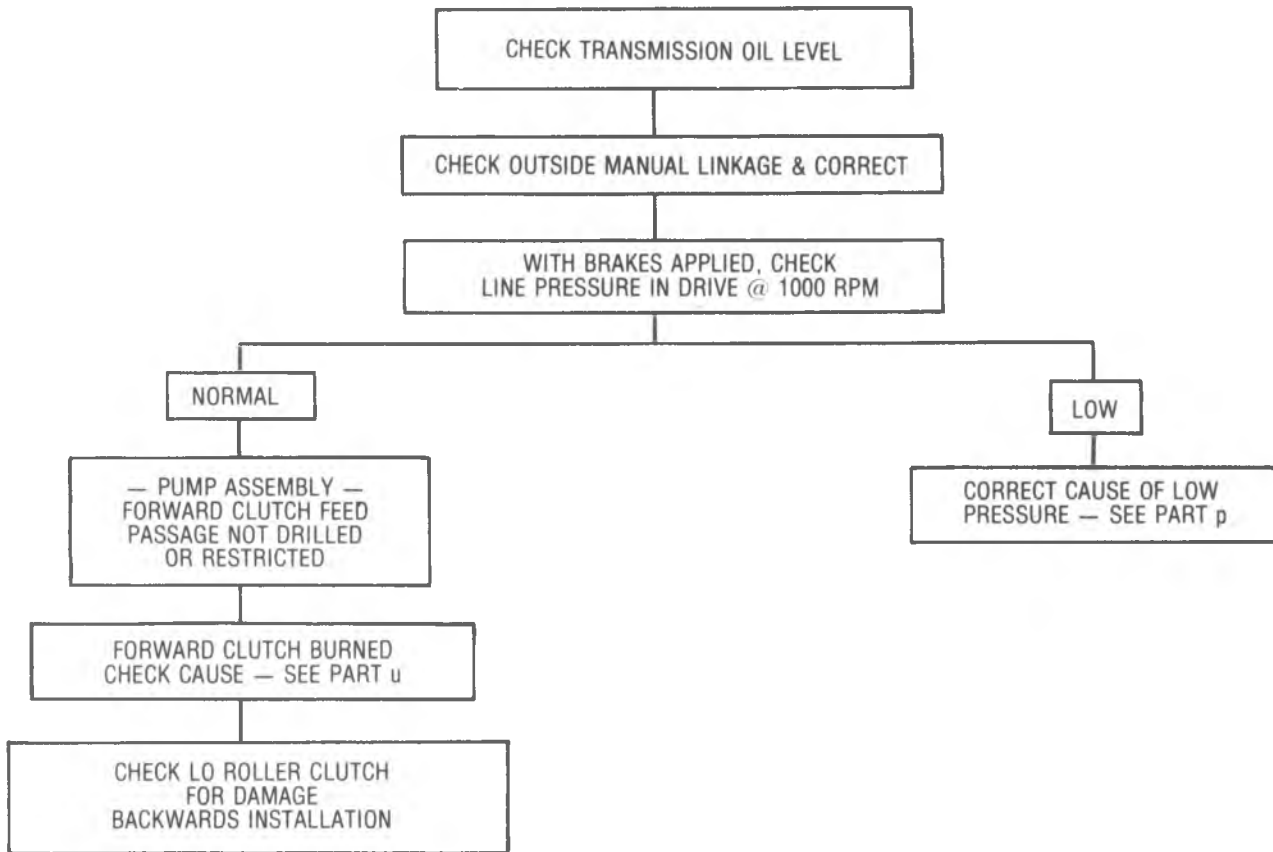

Figure 400-14 Diagnosis

R. NO DRIVE IN DRIVE RANGE



S. NO DETENT DOWNSHIFTS

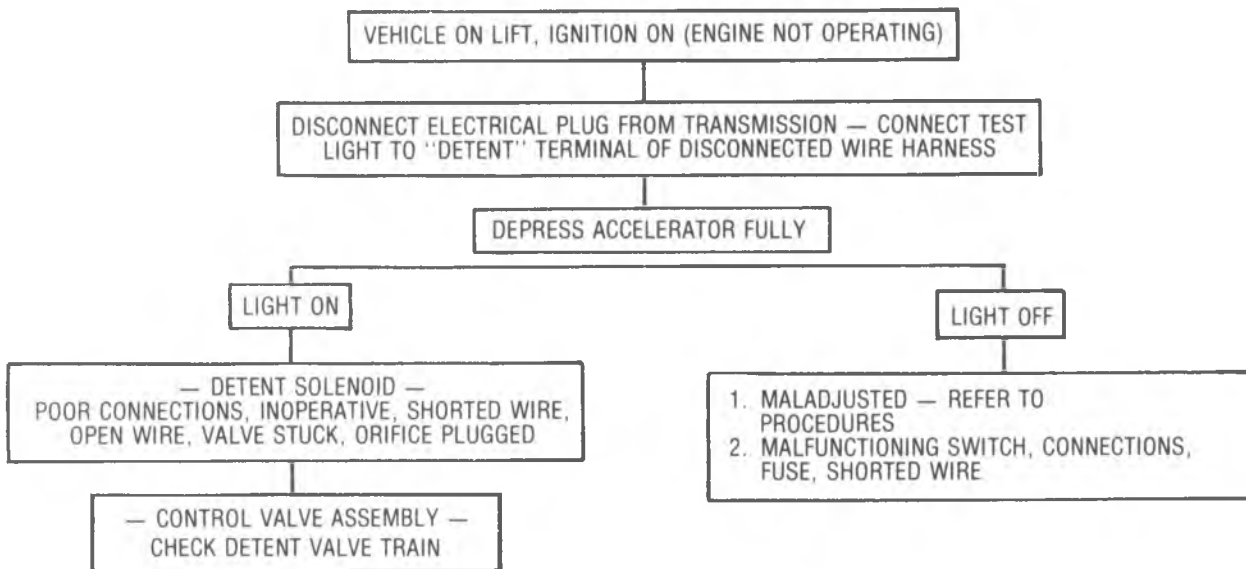
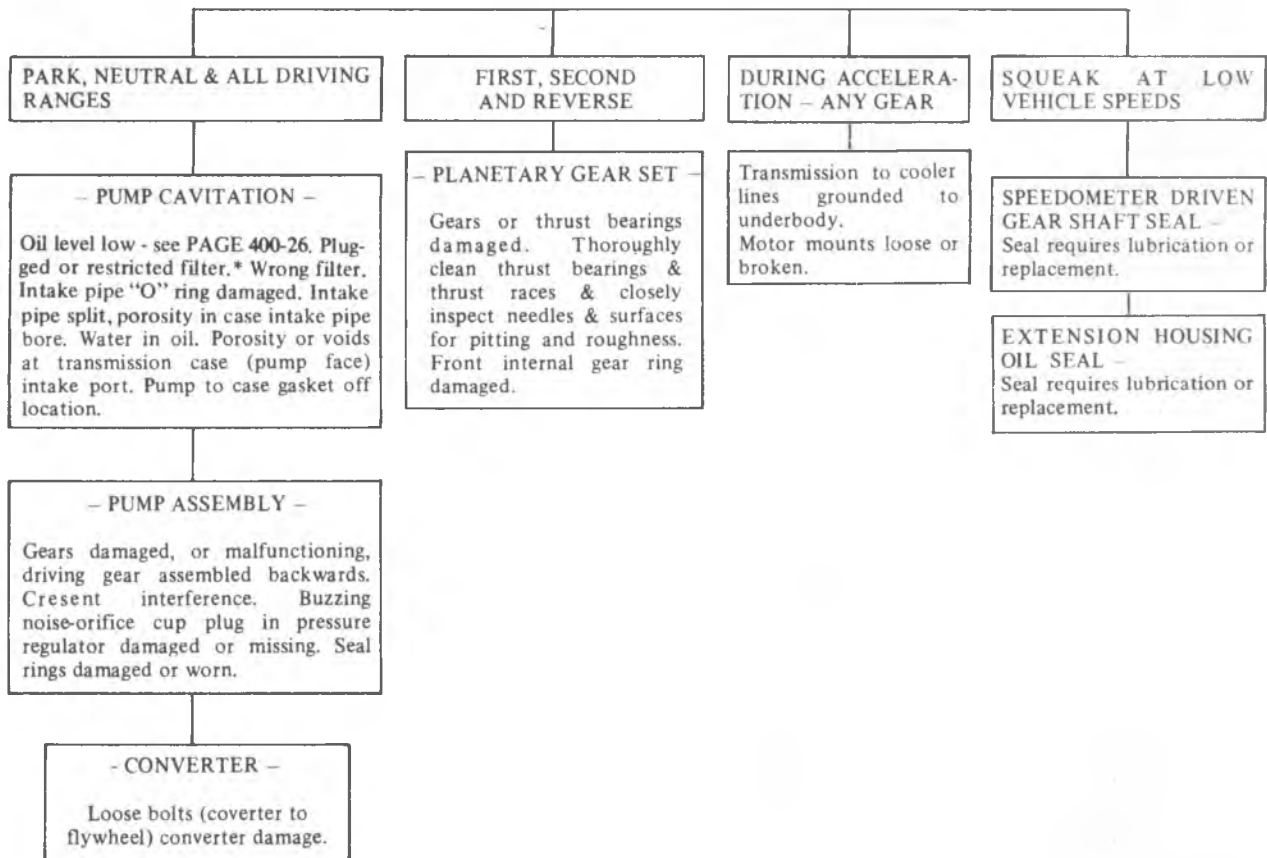

Figure 400-15 Diagnosis

**T. Transmission Noisy**

NOTE: Before checking transmission for what is believed to be "Transmission Noise," make certain the noise is not from the water pump, generator, air conditioner, power steering, etc. These components can be isolated by removing the proper belt and running the engine no more than two minutes at one time.



\*There is no approved service procedure for checking or cleaning the filter. If the filter is suspected of being plugged or restricted, it must be replaced.

Figure 400-16 Diagnosis

**1983 THM 400 CLUTCH APPLICATION CHART**

| MODEL  | FORWARD CLUTCH    |           |                           |                           | DIRECT CLUTCH            |                           |                           | INTERMEDIATE CLUTCH      |                           |                           |
|--------|-------------------|-----------|---------------------------|---------------------------|--------------------------|---------------------------|---------------------------|--------------------------|---------------------------|---------------------------|
|        | Flat Steel Plates |           | No. of Waved Steel Plates | No. of Composition Plates | No. of Flat Steel Plates | No. of Waved Steel Plates | No. of Composition Plates | No. of Flat Steel Plates | No. of Waved Steel Plates | No. of Composition Plates |
|        | No.               | Thickness |                           |                           |                          |                           |                           |                          |                           |                           |
| AD, AN | 4                 | .0915"    | 1                         | 5                         | 4                        | 1                         | 5                         | 2                        | 1                         | 3                         |

H 7A-17-6/81

Figure 400-17 Clutch Usage Chart

3. Allow throttle to return to closed position. One click should be heard from transmission.

4. If system performed as described above, downshift circuit is operating properly. If system does not perform as described above, proceed to step 5.

5. Use test light to check brown wire at connector on side of transmission case. Test light should light with throttle wide open and go out when throttle is released.

a. If system operates as described above, but did not perform properly during steps 1-3, replace solenoid after first checking to see that internal wiring is operational. Solenoid installation is described in this section.

b. If light fails to light with throttle in wide open position, the circuit is open. Proceed to step 6.

c. If light lights with throttle closed, the circuit is shorted. Proceed to step 9.

6. Remove air cleaner. Remove orange wire connector location at transmission downshift switch. Use test light to check from the bare terminal at switch with throttle wide open.

a. If test light lights, replace brown wire. Recheck system.

b. If test light fails to light, proceed to step 7.

7. Check black striped orange feed wire at transmission downshift switch with test light.

a. If test light lights, replace transmission downshift switch. Recheck system.

b. If test light fails to light, proceed to step 8.

8. Check transmission control fuse in fuse panel.

a. If necessary to replace fuse, recheck system.

b. If fuse is all right, it will be necessary to locate the open in the wiring. Test the circuit continuity from the black-striped orange wire at the downshift switch to the battery.

9. Remove air cleaner. Remove black-striped orange wire connector at transmission downshift switch. Use test light to check from the bare terminal at switch with throttle closed.

a. If test light fails to light, orange wire is shorted. Correct shorting condition.

b. If test light lights, proceed to step 10.

10. With throttle in closed position, check black striped orange feed wire at transmission downshift switch.

a. If test light fails to light, replace transmission downshift switch. Recheck system.

b. If test light lights, it will be necessary to locate the short in the wiring. Test the circuit from the black striped orange wire at the downshift switch to the battery.

## OIL LEAKS

The precautions that must be observed to prevent fluid leaks are as follows:

1. Use new gaskets and O-ring seals whenever there is a disassembly.

2. Use a very small amount of petrolatum to hold gaskets and thrust washers in place during assembly, or to seal gaskets. Never use gasket paste or shellac.

3. Make sure that composition cork and paper gaskets are not wrinkled or creased when installed. Make sure that gaskets have not stretched or shrunk during storage.

4. Make sure the square type O-ring seals are installed squarely and are not twisted during assembly.

5. Make sure that mating surfaces of castings are flat and smooth, free of deep scratches, chips, and burrs.

6. Torque fasteners to proper torque. When checking for oil leaks, first determine whether leak originates from transmission or engine. The original factory fill fluid in the transmission is formulated with a red aniline dye to assist in locating leaks. Red dye appearing in the leaking oil will give positive identification as to the location of the leak.

If oil leak is found to be in transmission, check for leak in following areas:

## Front End

It will be necessary to remove lower cover at front of transmission case to determine location of leaks at front end. To correct leaks at front end, it will be necessary to remove transmission from car.

1. Pump oil seal leak - Check pump oil seal to make certain it is correctly installed and not damaged.

When installing a new pump oil seal, make certain that bore is free from foreign material and that garter spring on seal is correctly positioned. Check finish of converter neck and bearing surface in pump body.

2. Pump assembly-to-case square cut O-ring or gasket damaged.

3. Rubber coated-washers on pump attaching screws damaged or missing.

4. Converter - Inspect converter for indications of leakage.

5. Pump drain back hole not open **Figure 400-23**.

## Extension Housing

1. Extension housing oil seal not installed properly or damaged.

2. Gasket (extension housing-to-case) improperly installed or damaged.

3. Extension housing-to-case attaching screws not torqued to specifications. Tighten to 32 N·m (23 foot-pounds).

4. Porous or cracked casting.

5. Propeller shaft front slip yoke scratched or corroded.

6. O-ring on output shaft, improperly installed or damaged.

## Transmission Case

1. Speedometer driven gear housing retainer attaching screw loose. Tighten to 24 N·m (18 foot-pounds).

2. Speedometer driven gear housing O-ring or lip seal damaged.

3. Governor cover attaching screws not tight. Tighten screws to 24 N·m (18 foot-pounds).

4. Damaged governor gasket.

5. Electrical connector O-ring damaged.

6. Parking pawl shaft cup plug not properly installed.

7. Manual shaft seal damaged.

8. Vacuum modulator damaged.

9. Vacuum modulator retainer screw loose. Tighten to 24 N·m (18 foot-pounds).

10. Vacuum modulator diaphragm damaged.

A ruptured diaphragm would allow transmission oil to be drawn into intake manifold and vacuum line. Usually the exhaust will be excessively smoky due to transmission oil added to the combustion. Oil level of transmission will also be low with no visible external leak.

11. Bottom pan gasket damaged.

12. Bottom pan attaching screws loose. Tighten to 16 N·m (12 foot-pounds).

13. Line pressure plug not tight. Tighten to no more than 13.5 N·m (10 foot-pounds).

14. Porous or cracked casting.

15. Vent pipe.

- a. Transmission over-filled.
- b. Water in oil.
- c. Pump to case gasket mispositioned.
- d. Foreign material between pump and case, or between pump cover and body.
- e. Case - Porous pump face improperly machined.
- f. Pump - Shy of stock, porous. Breather hole in pump cover plugged, **Figure 400-24**.
- g. Cut O-ring or intake on grommet on filter assembly.

### Oil Cooler Pipe Connections

1. Outside oil cooler pipe connections improperly installed or damaged. Also connectors in radiator and transmission.
2. Oil cooler pipe connections not tight. Tighten to 28 N·m (21 foot-pounds).
3. Flare on oil cooler pipes damaged at radiator or transmission.

### Leaking Out Filler Pipe

1. O-ring damaged or improperly installed on pipe.
2. Filler pipe not fully seated in case.

### Blowing Out Filler Pipe

1. Transmission over-filled.
2. Plugged vent cap.
3. Plugged vent hole in pump.
4. Damaged pump gasket.
5. Engine overheating.

### Internal Leaks

It will be necessary to remove bottom pan to determine location of internal leaks.

1. Governor pipes damaged.
2. Rear servo cover attaching screws not tight. Tighten to 24 N·m (18 foot-pounds).
3. Rear servo cover gasket damaged.
4. Control valve assembly spacer plate-to-case gasket damaged.
5. Control valve assembly attaching screws loose. Tighten to 11 N·m (8 foot-pounds).
6. Solenoid gasket damaged.

7. Solenoid attaching screws loose. Tighten to 13.5 N·m (10 foot pounds).

8. Intake pipe O-ring or filter grommet damaged causing a foaming condition.

9. Rear servo square cut O-ring improperly installed or damaged.

## TRANSMISSION DOWNSHIFT SWITCH

### Removal

1. Remove air cleaner.
2. Disconnect wire connectors.
3. Remove 2 screws that secure switch to switch bracket and remove downshift switch, **Figure 400-25**.

### Installation

1. Hold switch in on-car position and rotate switch actuating shaft clockwise until it stops. Install lever on shaft with notch on inside and lever in straight-up position.
2. Insert shaft into hole on throttle adapter plate.
3. Insert two mounting screws through switch mounting to mounting bracket and lightly tighten.
4. Adjust switch as described in this section.
5. Connect wires to terminals on switch.
6. Replace air cleaner.

### Adjustment

1. Remove carburetor air cleaner.
2. Make certain that carburetor is adjusted to specification and that throttle linkage is at low speed idle setting.
3. Loosen two mounting screws and insert a #42 (.094") wire gage size drill into the calibrating hole below lower wire terminal, **Figure 400-25**. Adjust position of switch so that lever just touches the carburetor adapter plate arm (stud on 6L).

With this adjustment the downshift switch should make contact above 60° throttle.

4. With switch positioned, tighten mounting screws and remove #42 (.094") gage from calibrating hole through switch.
5. Repeat step 3, if necessary.
6. Install air cleaner.



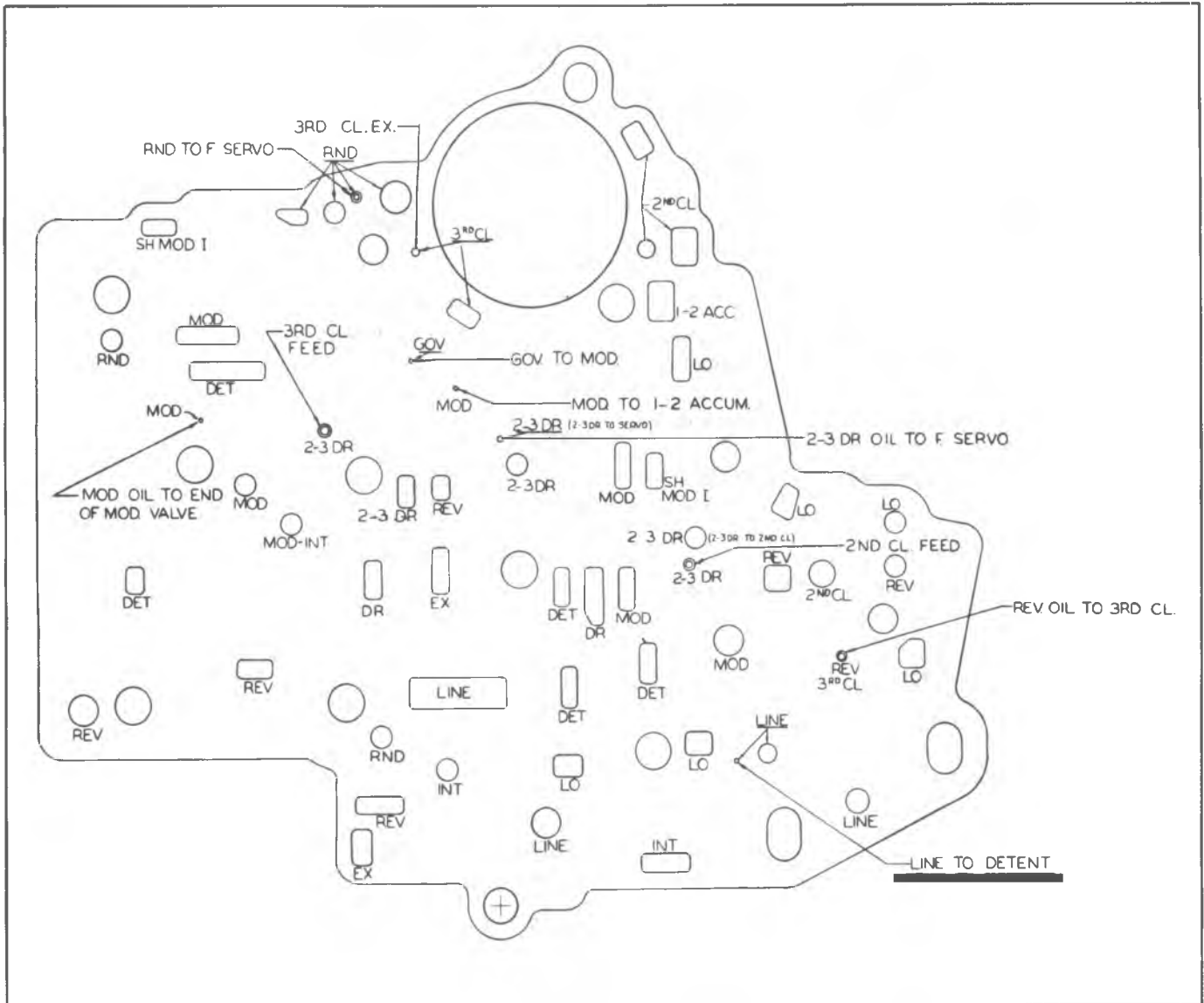

Figure 400-18 Spacer for Control Valve Assembly (Typical)

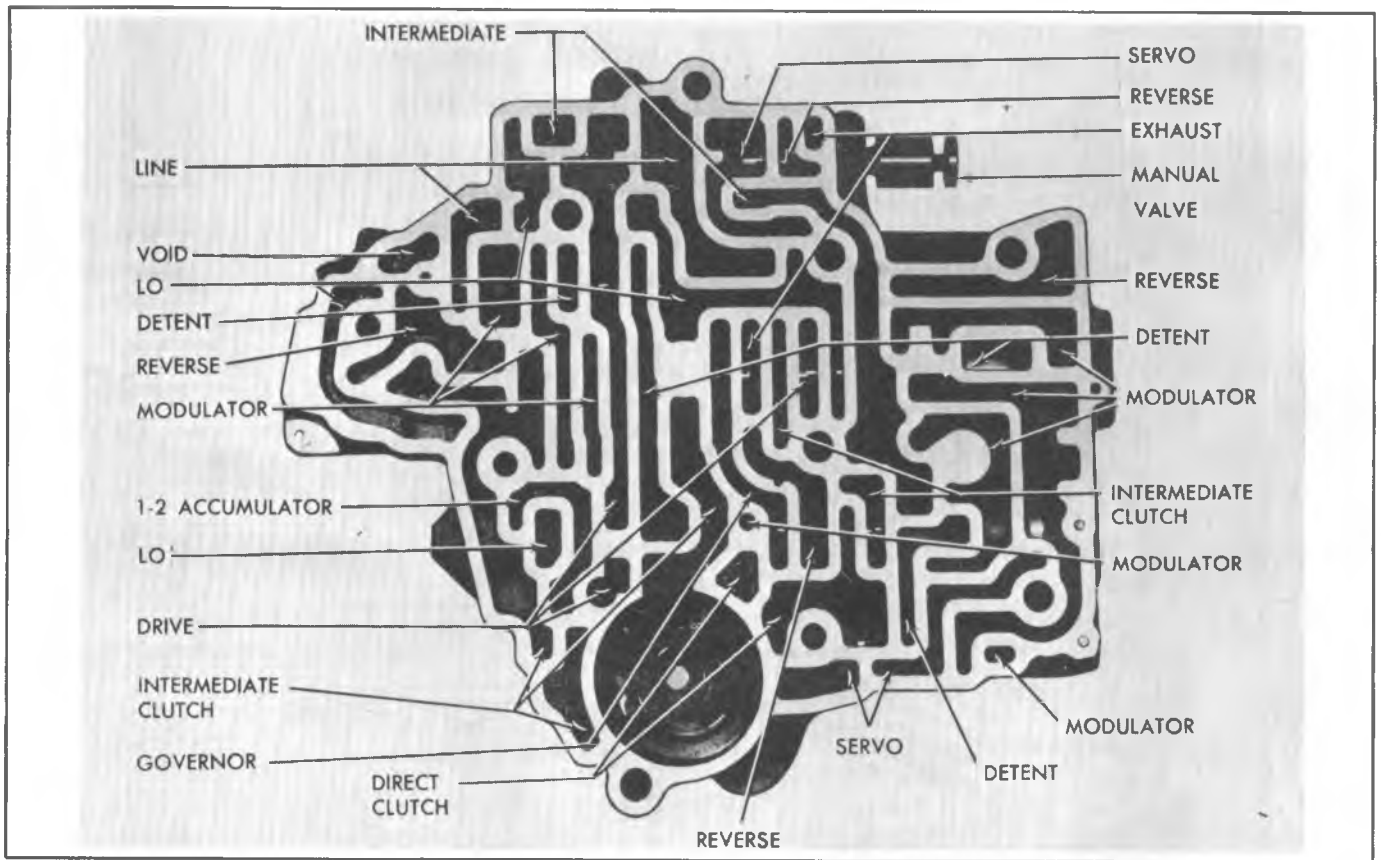

Figure 400-19 Control Valve Body Oil Passages

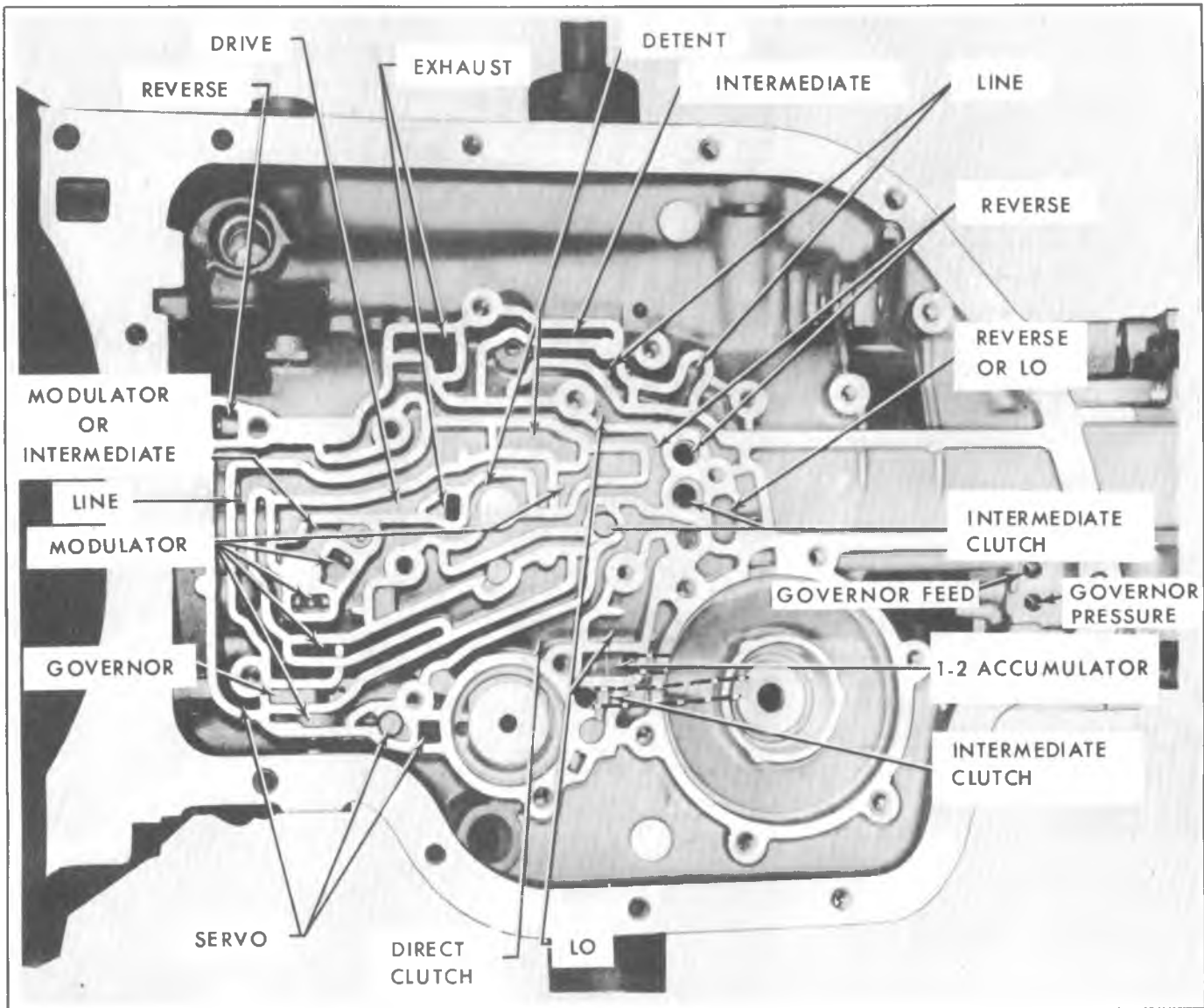

Figure 400-20 Transmission Case Oil Passages - Bottom View

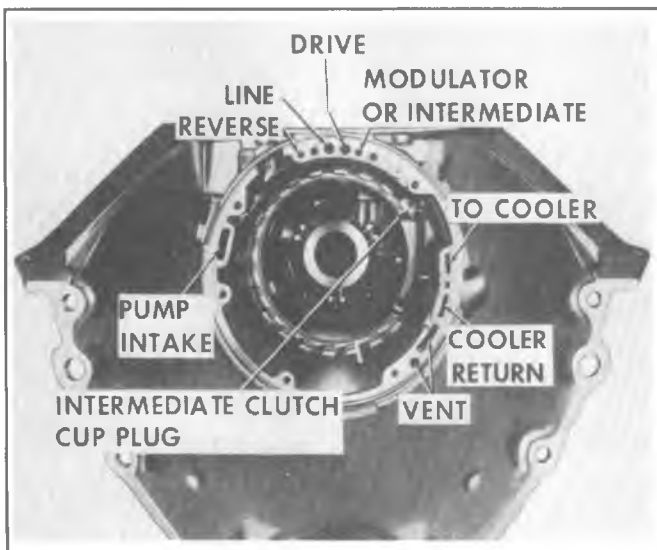

Figure 400-21 Transmission Case Oil Passages

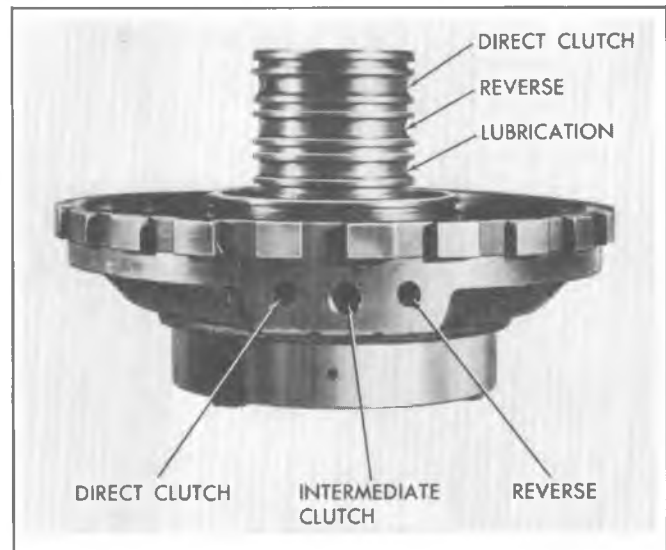

Figure 400-22 Center Support Oil Passages

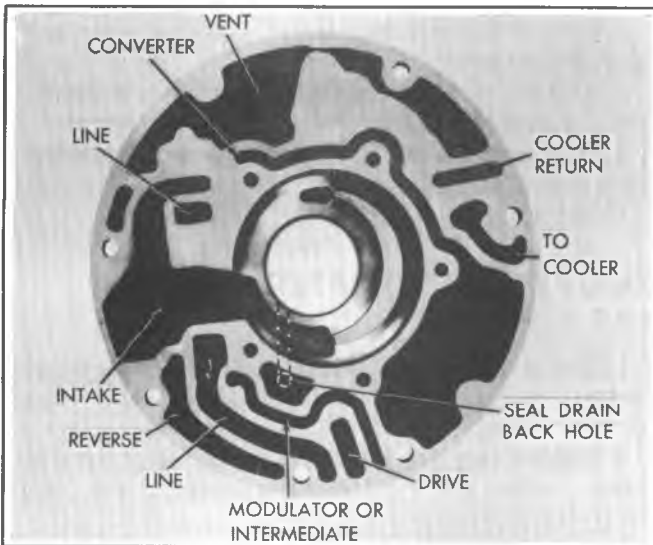

Figure 400-23 Pump Body Oil Passages

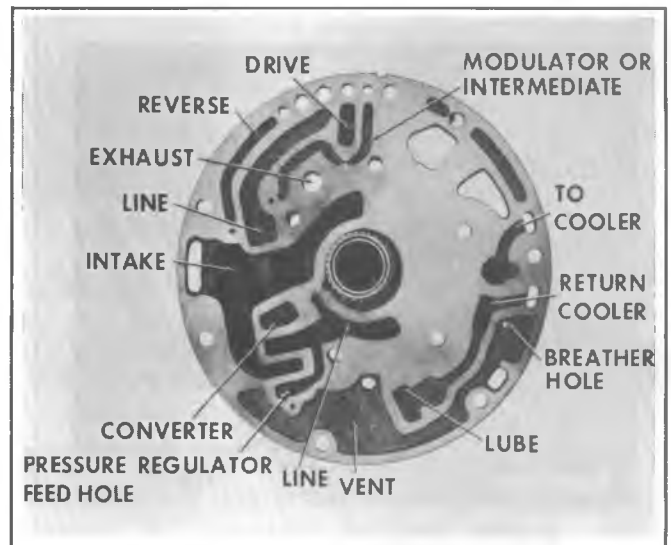

Figure 400-24 Pump Cover Oil Passages

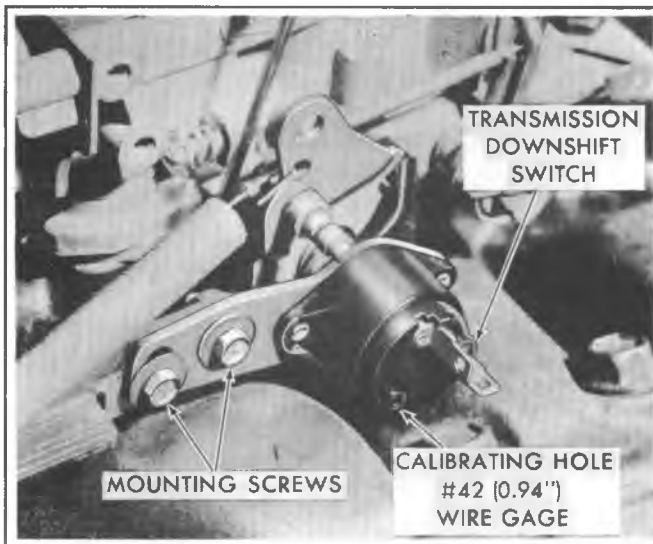

Figure 400-25 Downshift Switch

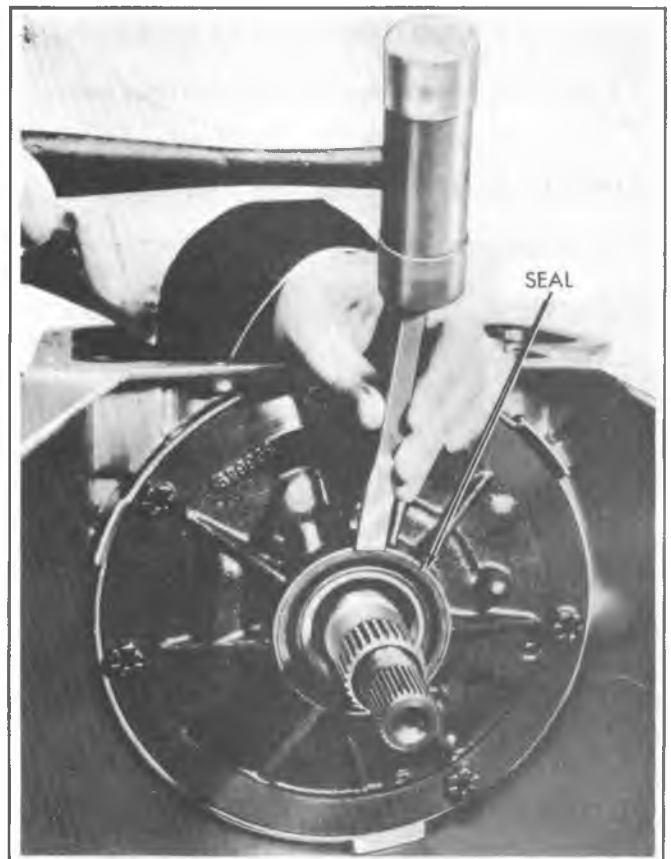

Figure 400-26 Removing Pump Oil Seal

## UNIT REPAIR

### PUMP OIL SEAL REPLACEMENT

1. Remove transmission assembly from car as described in this section.

2. Use hammer to drive chisel under lip of oil seal and pry seal out of pump body, **Figure 400-26**.

3. Before installing new seal, make certain bore is free of foreign material and that garter spring on seal is correctly positioned. Also check finish of converter neck and bearing surface in pump body.

Use a non-hardening sealer on outside of seal body before installing seal.

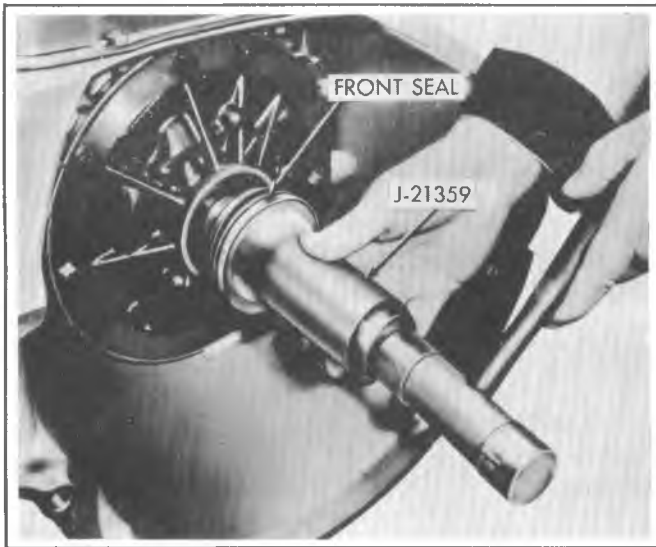

Figure 400-27 Installing Pump Oil Seal

4. Install new seal in pump body using Pump Oil Seal Installer, J-21359, **Figure 400-27**.
5. Install transmission assembly in car as described in this section.

### TRANSMISSION HOLDING FIXTURE

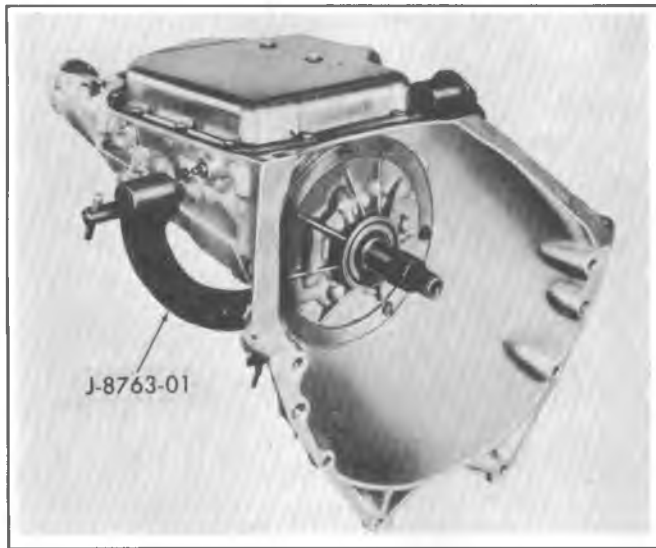

Figure 400-28 Transmission in Holding Fixture

On the following operations when the transmission is out of car remove converter from transmission and install Holding Fixture, J-8763-02, on transmission so that vacuum modulator will be located on side of Holding Fixture nearest the bench. Install fixture and transmission into Holding Fixture Base, J-3289-21, with bottom pan facing up, **Figure 400-28** and install lock pin in base. Provide container to catch any oil that may drain from transmission.

### REMOVE GOVERNOR ASSEMBLY

Unit may be removed without removing transmission or bottom pan.

1. Remove four attaching screws, governor cover, and gasket. Discard gasket.
2. Remove two bolts attaching transmission extension housing to cross member.
3. Move rear of transmission sideways enough to allow clearance for governor removal.
4. Remove governor assembly.

### REMOVE SPEEDOMETER DRIVEN GEAR ASSEMBLY

Unit may be removed without removing transmission or bottom pan, after removing speedometer cable from driven gear assembly.

1. Remove attaching screw and retainer from left side of case. Apply slight pressure to remove unit and speedometer driven gear.

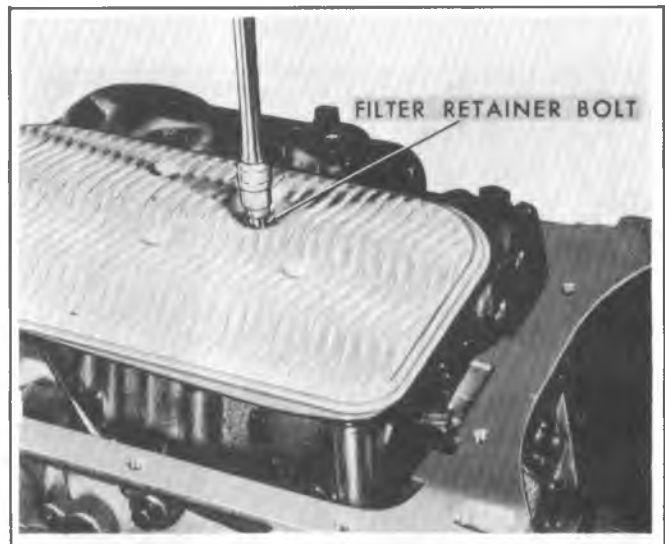

Figure 400-29 Removing Filter Retaining Bolt

### REMOVE INTAKE PIPE AND FILTER ASSEMBLY AND BOTTOM PAN

Unit may be removed with transmission in car. In cases of transmission malfunction, filter must be replaced.

1. Remove bottom pan attaching screws.
2. Remove bottom pan and gasket. Discard gasket. Drain oil from pan if transmission is in car.
3. Remove filter retainer bolt, **Figure 400-29**.
4. Lift out pump intake pipe and filter assembly, **Figure 400-30**.
5. Remove intake pipe from filter and discard filter.
6. Remove and discard intake pipe O-ring.

### REMOVE CONTROL VALVE ASSEMBLY, GOVERNOR PIPES, AND DETENT SPRING AND ROLLER ASSEMBLY

Units may be removed with transmission in car, after removing bottom pan.

1. Remove attaching screw and remove detent spring and roller assembly.

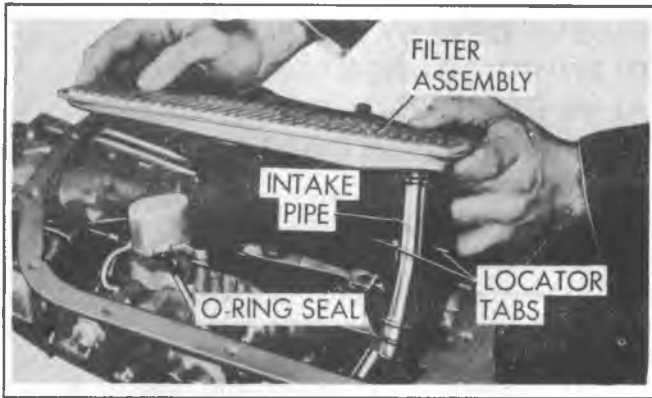

Figure 400-30 Removing Intake Pipe and Filter Assembly

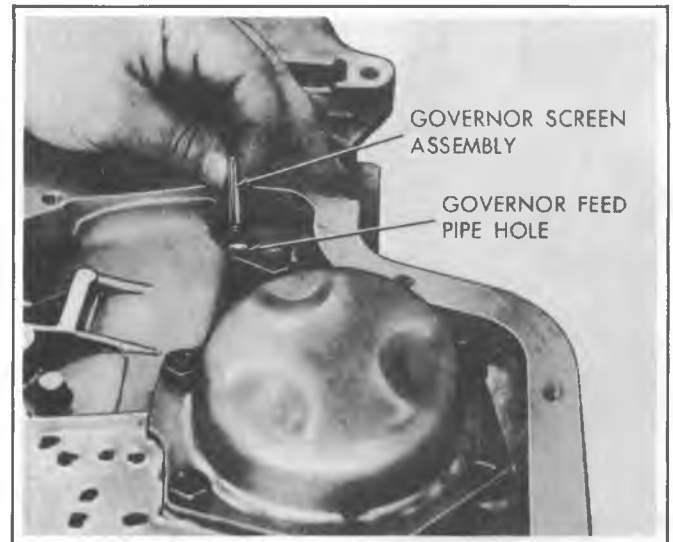

Figure 400-32 Removing Governor Screen Assembly

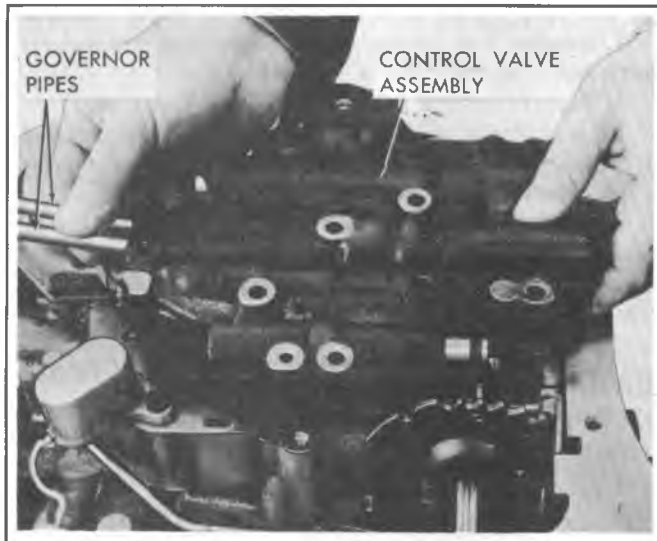

Figure 400-31 Removing Control Valve Assembly

2. Remove ten remaining control valve assembly attaching screws. Do not remove solenoid attaching screws at this time.

3. Remove control valve assembly with the two governor pipes attached, **Figure 400-31**.

**NOTICE:** Do not allow manual valve to fall out of its bore in control valve assembly. If transmission is in car be careful not to drop front servo group which may drop out as control valve assembly is removed.

4. Remove governor screen assembly from end of governor feed pipe or governor feed pipe hole in case. **Figure 400-32**. Clean screen in clean solvent and air dry.

5. Remove governor pipes from valve body. Governor pipes are interchangeable and need not be identified.

## REMOVE REAR SERVO ASSEMBLY

Unit may be removed with transmission in car after removing bottom pan and allowing fluid to drain.

1. Remove control valve assembly, and governor pipes as described in this section.

2. Remove six rear servo cover attaching screws, servo cover, and gasket. Discard gasket.

3. Remove rear servo assembly from transmission case, **Figure 400-33**.

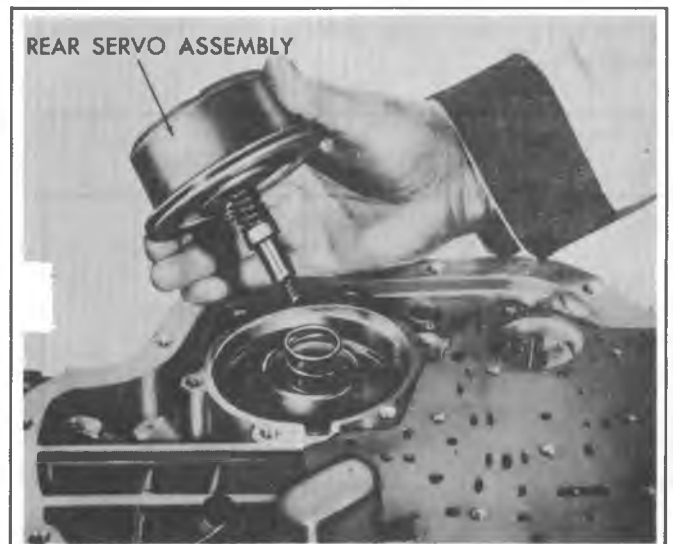

Figure 400-33 Removing Rear Servo Assembly

4. Remove servo accumulator spring.

5. Make band apply pin selection check, **Figure 400-35**, to determine proper size pin to use at time rear servo is assembled.

## BAND APPLY PIN SELECTION CHECK

Check may be made with transmission in car.

1. Remove bottom pan and allow fluid to drain.

2. Remove control valve assembly, governor pipes and rear servo.

3. Position Band Apply Pin Selector Gage, J-21370-6, on transmission case over rear servo bore, with hex nut on side of gage facing toward parking brake linkage, and smaller diameter end of Gage Pin, J-21370-5, in servo pin bore, **Figure 400-34**.

4. Secure gage with two 5/16-18 x 1 inch screws, tightening screws to 24 N·m (18 foot-pounds). Make certain that stepped gage pin is free to move up and down in both tool and servo pin bore. Stepped side of pin must face front of transmission case.



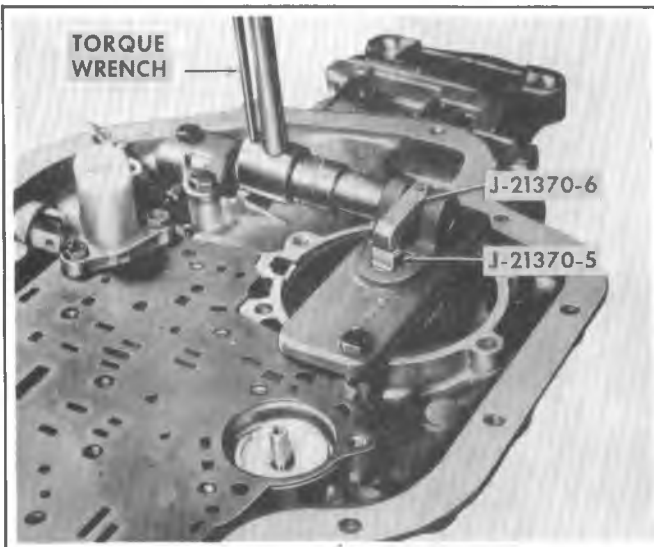

Figure 400-34 Band Apply Pin Selection Check

Band apply pins are available in three sizes as shown in Figure 400-35.

| IDENTIFICATION | LENGTH |
|----------------|--------|
| Three Rings    | Long   |
| Two Rings      | Medium |
| One Ring       | Short  |

Figure 400-35 Band Apply Pin Selection Chart

Identification ring is located on band lug end of pin. Selecting the proper pin is equivalent to adjusting band.

5. To determine proper size pin to use, apply 34 N·m (25 foot-pounds) torque on hex nut on side of gage, Figure 400-34. This will cause lever on top of gage to depress stepped gage pin into servo pin bore, simulating actual operating conditions. Note relation of steps on gage pin and machined surface on top of gage. Determine proper size pin as follows:

a. If machined surface on top of gage is even with or above upper step on gage pin, long size pin (three rings) is required.

b. If machined surface on top of gage is between upper and lower steps on gage pin, medium size pin (two rings) is required.

c. If machined surface on top of gage is even with or below step on gage pin, short size pin (one ring) is required.

6. If new pin is required, make note of pin size required, and remove gage from transmission case.

## REMOVE DETENT SOLENOID, SOLENOID CONNECTOR, CONTROL VALVE SPACER, GASKETS, CHECK BALLS, AND FRONT SERVO ASSEMBLY

Units may be removed with transmission in car.

1. Remove bottom pan and drain transmission fluid.
2. To remove control valve spacer, gasket, check balls, and front servo, remove control valve assembly and governor pipes.
3. Disconnect detent solenoid wire from electrical connector terminal.
4. Compress tabs on case connector and remove connector and O-ring from case. Discard O-ring.
5. Remove two detent solenoid attaching screws and remove solenoid assembly and gasket.
6. Remove control valve spacer plate from case. If operation is being performed on car, lower control valve spacer plate in a level plane so that check balls don't fall out. Then remove check balls from spacer plate.
7. Remove six check balls from cored passages in transmission case.
8. Lift front servo piston, retainer ring, pin, spring retainer, and spring out of transmission case.

## REMOVE REAR OIL SEAL AND EXTENSION HOUSING

Units may be removed with transmission in car.

1. If required, use hammer to drive chisel under oil seal flange and pry seal out of extension housing.
2. Remove six extension housing attaching screws and remove extension housing.
3. Remove and discard gasket from extension housing.

## FRONT UNIT END PLAY CHECKING PROCEDURE

Transmission must be removed from car.

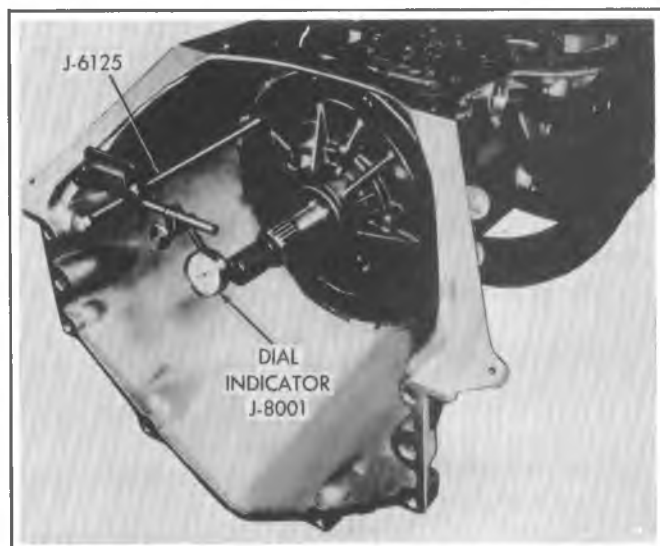

Figure 400-36 Front Unit End Play Check

1. Remove one oil pump attaching screw and rubber-coated washer at either 10 o'clock or 5 o'clock position.
2. Install Slide Hammer Bolt, J-6125-1, and Adapter, J-6125-2, in screw hole where attaching screw was removed, **Figure 400-36**.
3. Mount Dial Indicator, J-8001-02, on slide hammer bolt and index indicator to register with flat surface on end of turbine shaft, **Figure 400-36**.
4. Hold output shaft forward while pushing turbine shaft rearward to its stop.
5. Set dial indicator to zero.
6. Pull turbine shaft forward, **Figure 400-36**.

Resulting travel or end play for selection of washer for use at time of transmission assembly. End play should be .003 inch - .024 inch. The selective washer controlling this end play is the washer located between pump cover and forward clutch housing. If more or less washer thickness is required to bring end play within specifications, select proper washer from **Figure 400-37**.

| THICKNESS (INCH) | COLOR  | NO. |
|------------------|--------|-----|
| .060-.064        | Yellow | 0   |
| .071-.075        | Blue   | 1   |
| .082-.086        | Red    | 2   |
| .093-.097        | Brown  | 3   |
| .104-.108        | Green  | 4   |
| .115-.119        | Black  | 5   |
| .126-.130        | Purple | 6   |

Figure400-37 Front Unit Washer Thickness Chart

An oil-soaked washer may tend to discolor. If necessary, measure washer for thickness.

7. Remove dial indicator. If oil pump is to be removed, do not remove slide hammer assembly at this time.

## REMOVE OIL PUMP

Transmission must be removed from car.

1. If not done previously, perform the following steps:
  - a. Remove one oil pump attaching screw and rubber-coated washer at either 10 o'clock or 5 o'clock position.
  - b. Install Slide Hammer Bolt, J-6125-1, and Adapter, J-6125-2, in screw hole where attaching screw was removed, **Figure 400-38**.
2. Remove other pump attaching screws and washers.
3. Install Slide Hammer Bolt, J-6125-1, and Adapter, J-6125-2, into other threaded hole at 10 o'clock or 5 o'clock position in pump body and drive outward with slide hammers to remove pump assembly from transmission case, **Figure 400-38**.

**NOTICE:** Drive outward in unison on both slide hammer assemblies to prevent cocking pump assembly in case.

4. Remove slide hammer assemblies from pump.

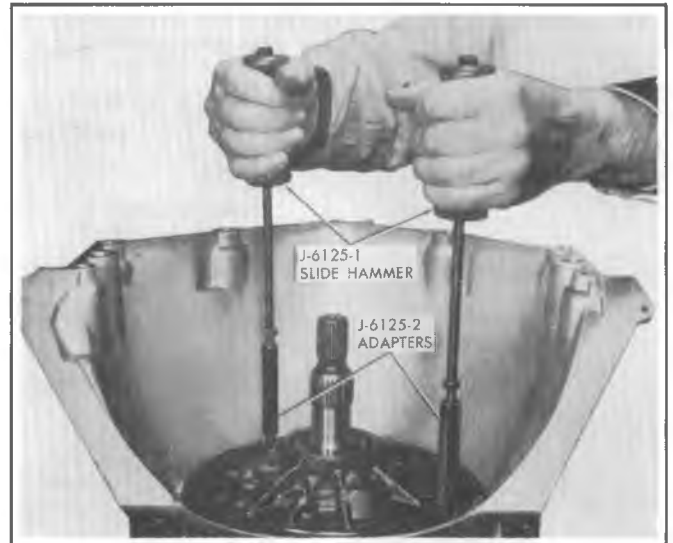

Figure400-38 Removing Pump Assembly

5. Remove and discard pump square cut O-ring and gasket.

## REMOVE DETENT LEVER, MANUAL SHAFT, AND PARKING LINKAGE

Units may be removed with transmission in car.

1. Drain transmission fluid by removing bottom pan.
  2. Remove manual linkage from manual lever and remove detent spring and roller assembly from control valve assembly, **Figure 400-39**.
  3. Remove pin securing manual shaft to case. If procedure is being performed on car, bend pin to remove it.
  4. Loosen locknut securing inside detent lever to manual shaft.
  5. Pry or work inside detent lever loose from manual shaft and remove locknut.
  6. Remove manual shaft, parking actuator rod and detent lever from case. Inspect manual shaft lip seal as required, **Figure 400-39**.
  7. Remove parking lock bracket attaching screws and remove bracket.
  8. Remove parking pawl return spring.
- The following steps are to be completed only if one or more of the parts involved require replacement.
9. Remove spring retainer from parking pawl shaft.
  10. Remove parking brake pawl shaft cup plug by placing screwdriver between parking pawl shaft and case rib and prying outward, **Figure 400-40**.
  11. Remove parking pawl shaft and parking pawl.

## REMOVE TURBINE SHAFT, FORWARD CLUTCH HOUSING, DIRECT CLUTCH ASSEMBLY, SUN GEAR SHAFT, AND FRONT BAND

Transmission must be removed from car. Requires removal of oil pump.

1. Remove turbine shaft and forward clutch assembly from transmission, **Figure 400-41**.



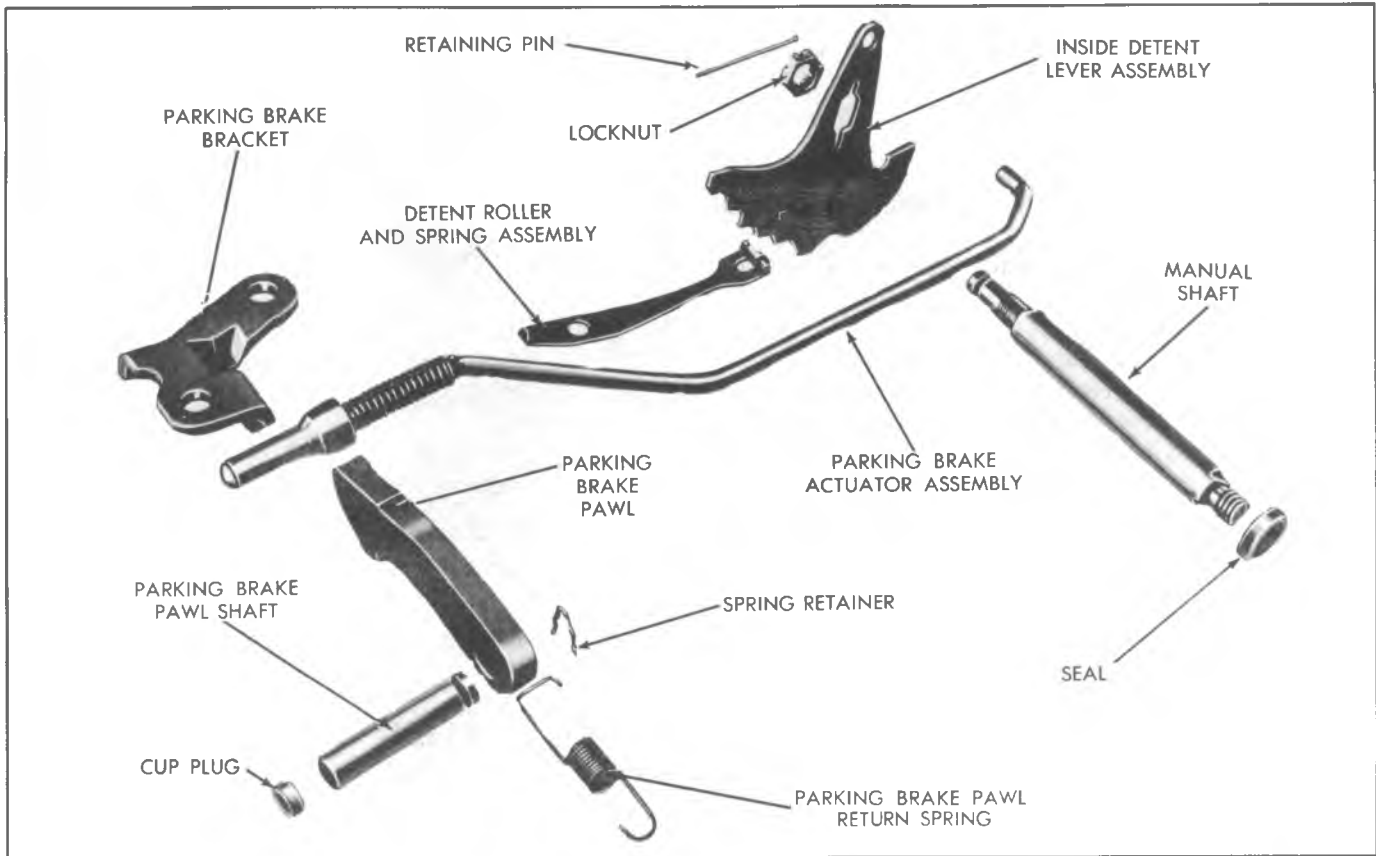

Figure 400-39 Manual and Parking Linkage

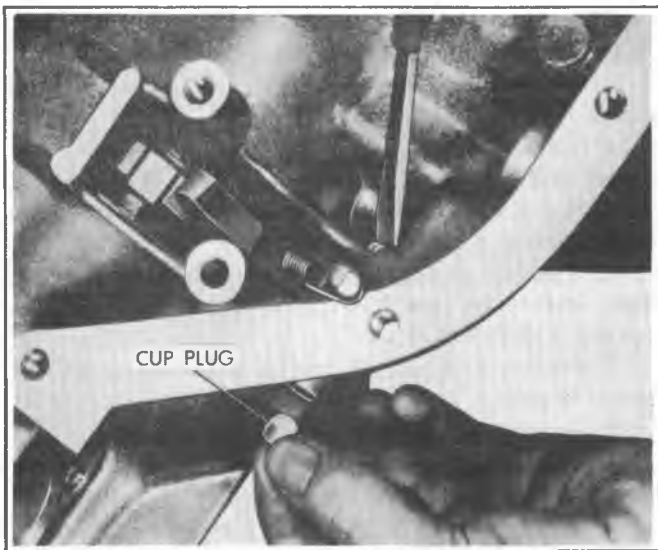

Figure 400-40 Removing Cup Plug

2. Remove forward clutch hub to direct clutch housing thrust washer if it did not come out with forward clutch assembly.

3. Remove direct clutch and intermediate roller assembly, **Figure 400-42**. Sun gear shaft may come out with direct clutch assembly.

4. Remove sun gear shaft if not previously removed. See **Figure 400-43**.

5. Remove front band assembly.

Check rear unit end play at this time. Proceed as follows:



Figure 400-41 Removing Forward Clutch Assembly

### REAR UNIT END PLAY CHECKING PROCEDURE

Transmission must be removed from car. Requires removal of extension housing.

1. Install Speedometer Puller Bolt, J-21797, in one of the bolt holes on end of transmission case.

2. Mount Dial Indicator, J-8001, on Bolt, J-21797, and index indicator to register with flat surface on end of output shaft, **Figure 400-44**.

3. Set dial indicator to zero.

4. Move output shaft in and out. Note resulting travel or end play for selection of washer for use at time of transmission assembly. End play should be .007 inch - .019 inch.



Figure 400-42 Removing Direct Clutch and Intermediate Roller Assembly

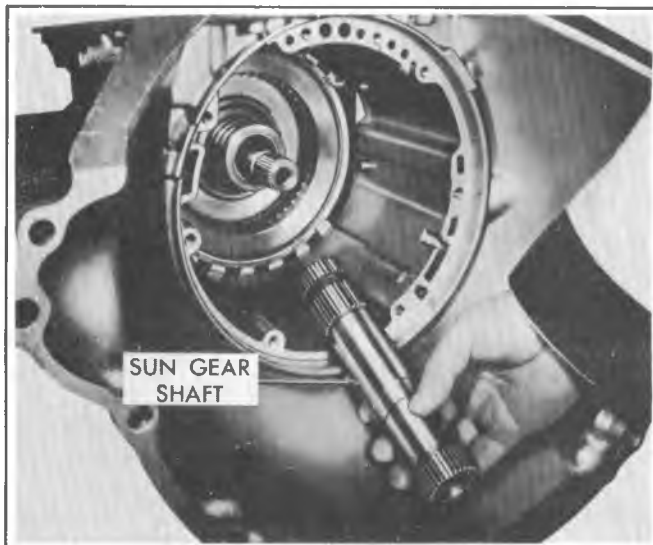

Figure 400-43 Removing Sun Gear Shaft

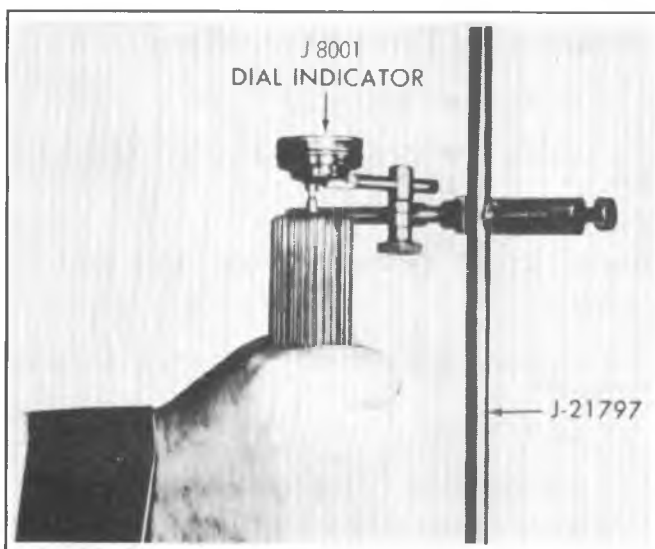

Figure 400-44 Checking Rear Unit End Play

The selective washer controlling this end play is the steel washer with the three tabs, located between thrust washer and rear face of transmission case. Notches and/or numerals on the tabs serve to identify washer thickness.

If a different washer thickness is required to bring end play within specifications, it can be selected from Figure 400-45. The table will show identification notches numerals or both.

| THICKNESS (INCH) | IDENTIFICATION NOTCH AND/OR NUMERAL |   |
|------------------|-------------------------------------|---|
| .074-.078        | None                                | 1 |
| .082-.086        | On Side of 1 Tab                    | 2 |
| .090-.094        | On Side of 2 Tabs                   | 3 |
| .098-.102        | On End of 1 Tab                     | 4 |
| .106-.110        | On End of 2 Tabs                    | 5 |
| .114-.118        | On End of 3 Tabs                    | 6 |

Figure 400-45 Rear Unit Washer Thickness Chart

## REMOVE REMAINING COMPONENTS

Transmission must be removed from car. Requires removal of bottom pan, control valve assembly and governor pipes, rear servo assembly, control valve spacer, two gaskets, check balls, front servo assembly, oil pump, turbine shaft, forward clutch housing, direct clutch assembly, sun gear shaft and front band.

1. Remove center support bolt from transmission case using 3/8 inch 12-point thin wall deep socket.

2. Remove intermediate clutch backing plate to case snap ring.

3. Remove intermediate clutch backing plate, and three composition and three steel clutch plates.

4. Using needle nose pliers, or screwdriver, remove center support to case snap ring.

5. Install Tool, J-21795, on end of main shaft so that tangs engage groove in shaft. Tighten screw on tool to secure tool on shaft and prevent movement of roller clutch during removal of gear unit assembly, Figure 400-46.

6. Install proper diameter length of pipe over output shaft to be used as a handle and to prevent spline damage to case bushing when removing gear unit, center support, and reaction carrier.

Loosen transmission holding fixture pivot pin slightly, so that gear unit assembly does not bind when it is removed from case.

7. With transmission case in a horizontal position, shift complete assembly toward front of case to facilitate removal of assembly from case. Remove complete gear unit assembly from case.

Be careful not to drop or bump assembly in transmission case during removal. This could result in damage to output shaft bushing in case as well as to assembly itself.

8. Remove output shaft to case thrust washer from output shaft or case.

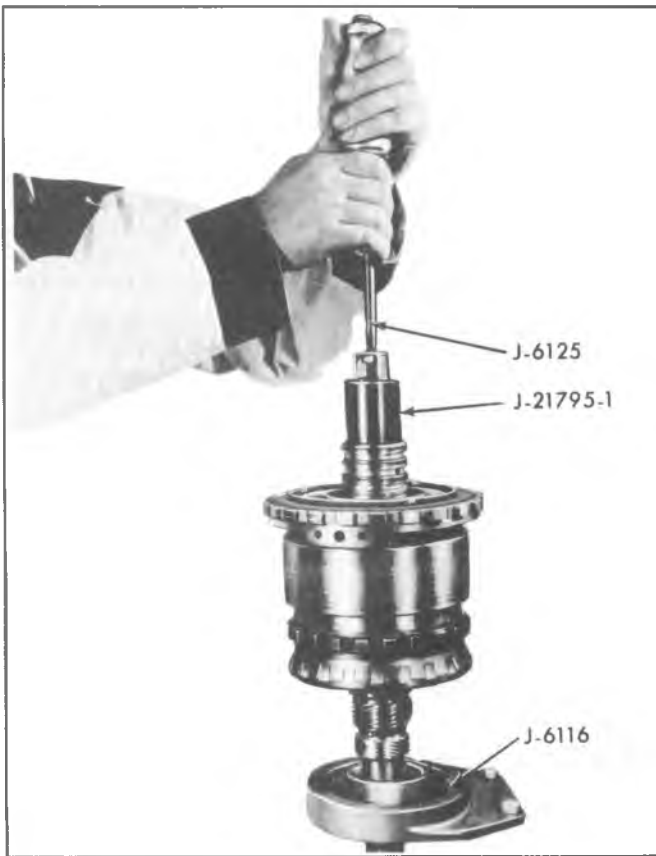

Figure 400-46 Gear Unit Holding Fixture

9. Using Adapter, J-21364, in Rear Unit Holding Fixture, J-6116-01, place gear unit assembly in holding fixture with mainshaft pointing upward, **Figure 400-46**. Remove Tool J-21795.

10. Remove rear unit selective washer from transmission case.

11. Remove the center support to case spacer, refer to **Figure 400-76**.

12. Remove rear band assembly. To facilitate removal, rotate band lugs away from pins and pull band assembly out of transmission case.

13. Remove center support assembly from reaction carrier by lifting straight upward.

14. Remove center support to reaction carrier thrust washer, **Figure 400-47**.

Thrust washer may have stuck to back of center support. If so, remove from center support.

15. Remove reaction carrier and roller clutch assembly from output carrier, **Figure 400-48**, and remove roller clutch assembly from reaction carrier.

## TRANSMISSION DISASSEMBLY, CLEANING, INSPECTION AND ASSEMBLY OF INDIVIDUAL UNITS

Inspect each part thoroughly after the transmission and individual units have been disassembled and cleaned, to determine which parts should be replaced. It is very important to distinguish between parts that are simply "worn-in", and those parts worn to the extent that they affect operation of the unit. Only "worn-out", broken or damaged parts should be replaced.



Figure 400-47 Removing Center Support to Reaction Carrier Thrust Washer

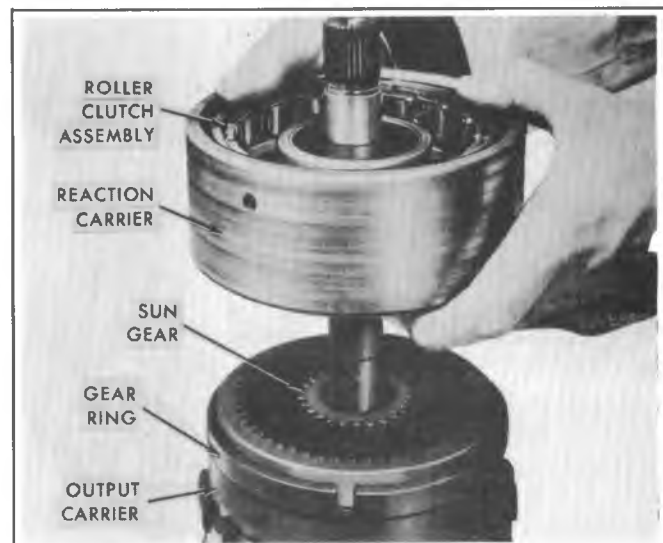

Figure 400-48 Roller Clutch Assembly

## Inspection of Torque Converter

1. Check converter for leaks.
2. Check converter hub surfaces for signs of scoring or wear.

## Inspection of Vacuum Modulator and Valve

1. Inspect vacuum modulator for any signs of bending or distortion.
2. Inspect O-ring seat for damage.
3. Inspect modulator valve for nicks or damage.
4. Check freeness of valve operation in case bore.
5. Check modulator for damaged bellows.

Modulator plunger is under approximately 16 pounds pressure. If bellows is damaged, plunger will have very little pressure. Use procedure outlined in Diagnosis Part V.

## Inspection of Extension Housing

1. Inspect bushing and rear seal for excessive wear or damage.
2. Inspect gasket mounting face for damage.
3. Inspect housing for cracks or porosity.
4. Be sure rear seal drain back port is not blocked.

## Inspection of Detent Lever, Manual Shaft, and Parking Linkage

1. Inspect parking actuator rod for cracks, or broken spring retainer lugs.
2. Inspect actuator spring for damage.
3. Inspect actuator for a free fit on actuator rod.
4. Inspect parking pawl for cracks or wear.
5. Inspect manual shaft and lip seal for damage.
6. Inspect inside detent lever for cracks or a loose pin.
7. Inspect parking pawl return spring for deformed coils or ends.
8. Inspect parking bracket for cracks or wear.
9. Inspect detent spring and roller assembly.

## Inspection of Transmission Case

1. Inspect case assembly for cracks, porosity or interconnected passages, **Figure 400-20** and **Figure 400-21**.
2. Check for good retention of band anchor pins.
3. Inspect all threaded holes for thread damage.
4. Inspect intermediate clutch driven plate lugs for damage or brinelling.
5. Inspect snap ring grooves for damage.
6. Inspect governor assembly bore for scratches or scoring.
7. Inspect modulator valve bore for scoring or damage.
8. Inspect cup plug inside case for good staking and sealing, **Figure 400-21**.

If the case assembly requires replacement, make sure the center support to-case spacer is removed from the old case and reinstalled in the new case.

If the case assembly requires replacement, remove the nameplate from the old case and reinstall it onto the new case, using the truss head nameplate attaching screw that is serviced with the case,

## GOVERNOR ASSEMBLY

All components of the governor assembly, **Figure 400-49**, with the exception of the driven gear, are a select fit and each assembly is calibrated. The governor, including the driven gear, is serviced as a complete assembly. However, the driven gear can also be serviced separately.

It is necessary to disassemble the governor assembly in order to replace the driven gear. Disassembly may also be necessary due to foreign material causing improper operation. In such cases, proceed as follows:

### Disassembly

1. Cut off one end of each governor weight pin and remove pins, governor thrust cap, governor weights, and springs. Governor weights are interchangeable from side to side and need not be identified.

2. Remove governor valve from governor sleeve. Be careful not to damage valve.

3. Perform the following inspections and replace governor driven gear if necessary.

### Inspection

1. Wash all parts in cleaning solvent, air dry and blow out all passages.
2. Inspect governor sleeve for nicks, burrs, scoring and galling.
3. Check governor sleeve for free operation in bore of transmission case.
4. Inspect governor valve for nicks, burrs, scoring or galling.
5. Check governor valve for free operation in bore of governor sleeve.
6. Inspect governor driven gear for nicks, burrs, or damage.
7. Check governor driven gear for looseness on governor sleeve.
8. Inspect governor springs for distortion or damage.
9. Check governor weights for free operation in their retainers.
10. Check valve opening at entry (.020" minimum) with a feeler gage, holding governor as shown with governor weights extended completely outward, **Figure 400-50**.
11. Check valve opening at exhaust (.020" minimum) with a feeler gage, holding governor as shown with governor weights completely inward, **Figure 400-51**.

### Governor Driven Gear Replacement

To facilitate governor repair in the field, a governor driven gear and replacement pins are available for service use. The service package contains a nylon driven gear, two governor weight retaining pins and one governor gear retainer split pin. Replacement of gear must be performed with care in the following manner:

1. Drive out governor gear retaining split pin using small punch, **Figure 400-52**.
2. Support governor on 3/16 inch plates installed in exhaust slots of governor sleeve, place in arbor press and, with a long punch, press gear out of sleeve.
3. Carefully clean governor sleeve of chips that remain from original gear installation.
4. Support governor on 3/16 inch plates installed in exhaust slots of sleeve, position new gear in sleeve and, with a suitable socket, press gear into sleeve until nearly seated. Carefully remove any chips that may have shaved off gear hub and press gear in until it bottoms on shoulder.
5. A new pin hole must be drilled through sleeve and gear. Locate hole position 90° from existing hole, center punch, and then while supporting governor in press, drill new hole through sleeve and gear using a 1/8 inch drill.
6. Install split retainer pin.
7. Wash governor assembly thoroughly to remove any chips that may have collected.

### Assembly

1. Install governor valve in bore of governor sleeve.
2. Install governor weights and springs, and thrust cap on governor sleeve.

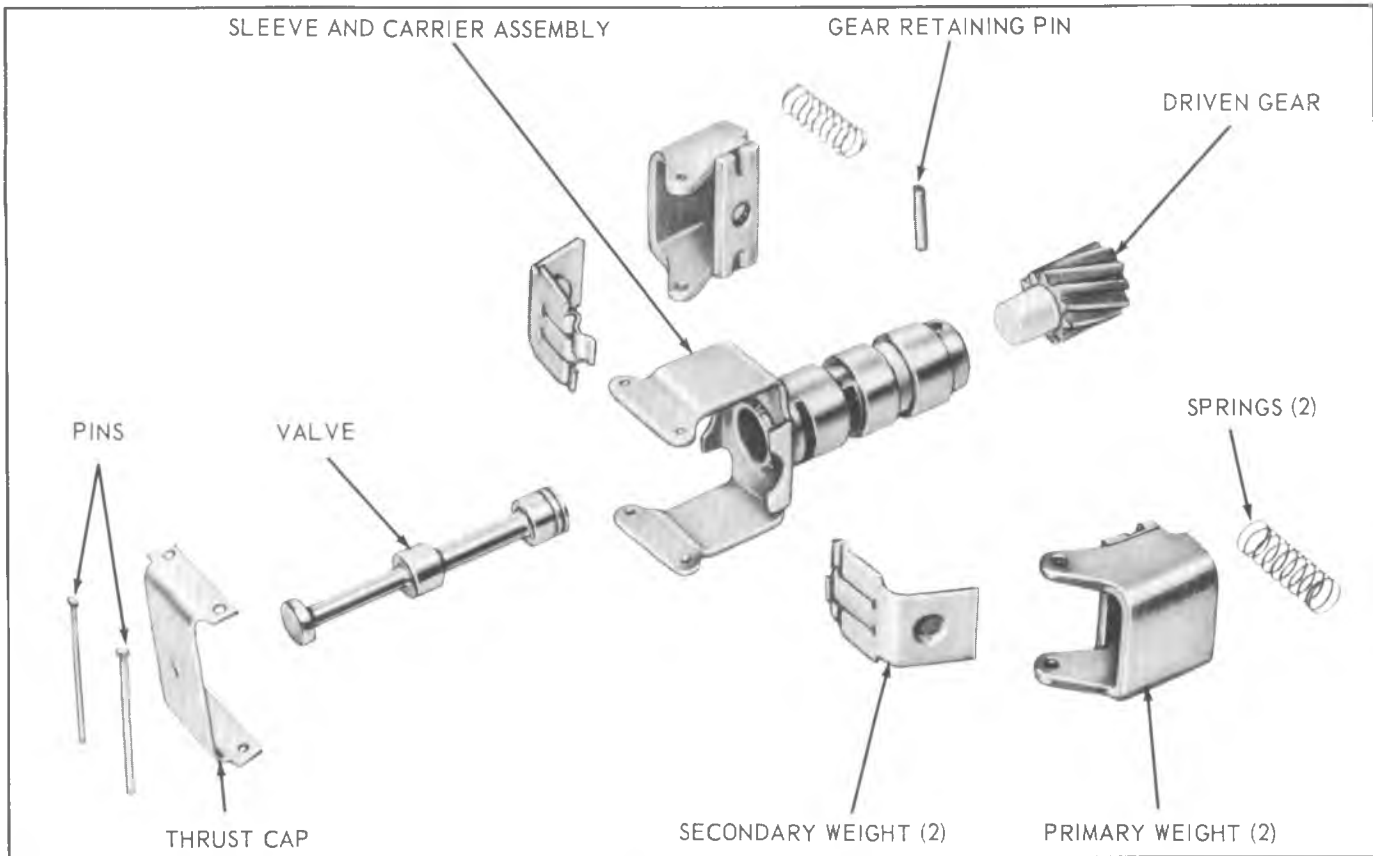

Figure400-49 Governor Assembly - Disassembled View



Figure400-50 Checking Valve Opening - Weights Extended

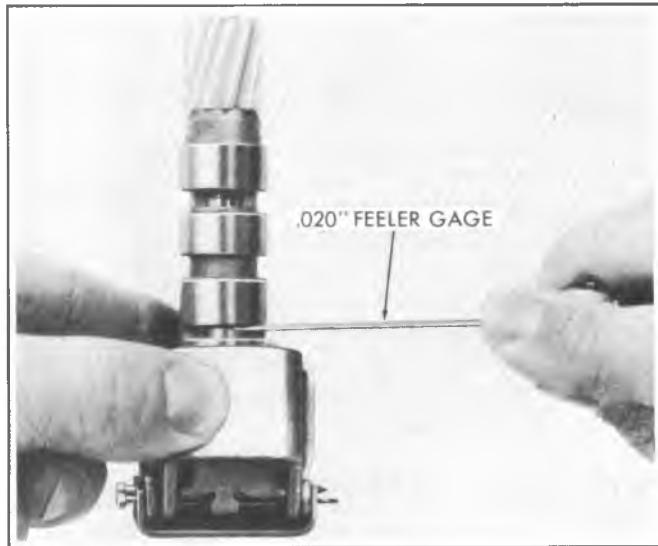

Figure400-51 Checking Valve Opening - Weights Inward

3. Align pin holes in thrust cap, governor weight assemblies, and governor sleeve, and install new pins. Crimp both ends of pins to prevent them from falling out.

4. Check governor weight assemblies for free operation on pins and valve for freeness in sleeve bore.

## SPEEDOMETER DRIVEN GEAR ASSEMBLY

### Disassembly

1. Remove speedometer driven gear from sleeve.

2. Remove O-ring from speedometer driven gear sleeve.
3. Remove C-wire ring retaining sleeve to gear lip seal.
4. Remove lip seal.

### Inspection

1. Inspect gear for damaged teeth or shaft.
2. Inspect sleeve or sensor for scores, damaged threads or cracks.
3. Inspect seals for cuts or damage.
4. Inspect sensor for corrosion on wire terminal.

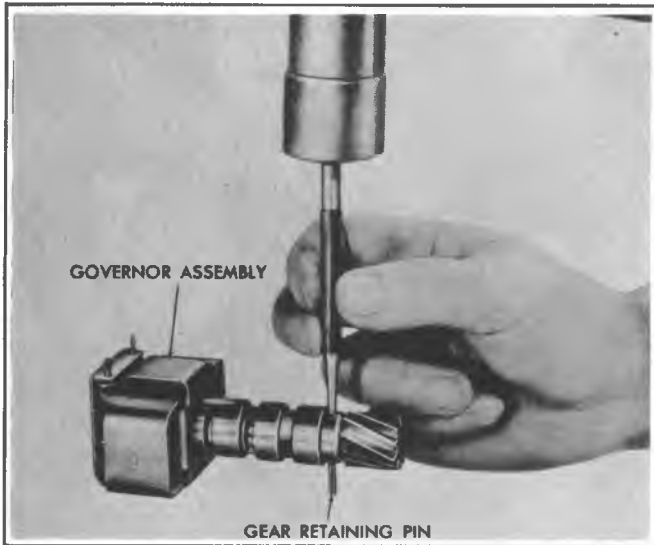

Figure 400-52 Removing Governor Driven Gear Retaining Pin

**Assembly**

1. Install sleeve to gear lip seal.
2. Install C-wire retaining ring.
3. Install O-ring on speedometer driven gear sleeve.
4. Install gear in sleeve.

**CONTROL VALVE ASSEMBLY**

**Disassembly**

When disassembling control valve assembly, **Figure 400-53**, make certain that springs are accurately identified so that they can be properly reassembled.

1. Position control valve assembly with gasket surface up and accumulator pocket on bottom.
2. Remove manual valve from upper bore.
3. Install Control Valve Accumulator Piston Installer, J-21885 or J-22269-01, on accumulator piston, compress piston and remove E-ring retainer, **Figure 400-54**.
4. Remove Installer, J-21885 or J-22269-01, and remove accumulator piston and spring.
5. Using pin punch, remove retaining pin from upper right bore, pressing on pin from outer side of valve body. Remove 1-2 modulator bushing, 1-2 regulator valve and spring, 1-2 detent valve and 1-2 shift valve from upper right bore.  
1-2 regulator valve and spring may be inside of 1-2 modulator bushing.
6. Using punch, remove retaining pin from center right bore, pressing on pin from outer side of valve body. Remove 2-3 modulator bushing, 2-3 shift valve spring, 2-3 modulator valve, 3-2 intermediate spring and 2-3 shift valve from center right bore.  
2-3 modulator valve will be inside of 2-3 modulator bushing.
7. Using pin punch, remove retaining pin from lower right bore, pressing on pin from outer side of valve body.

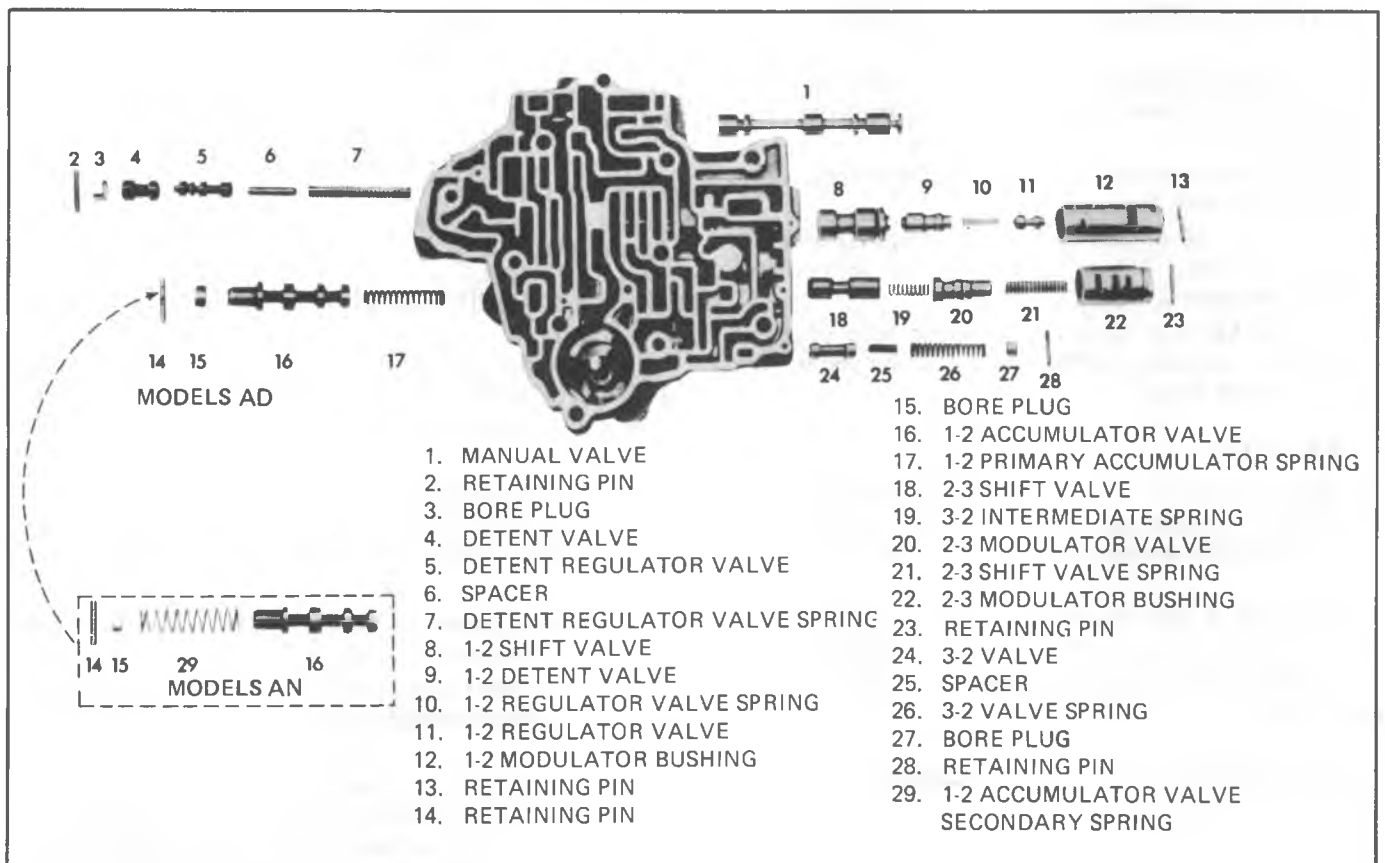

Figure 400-53 Control Valve Assembly - Disassembled View

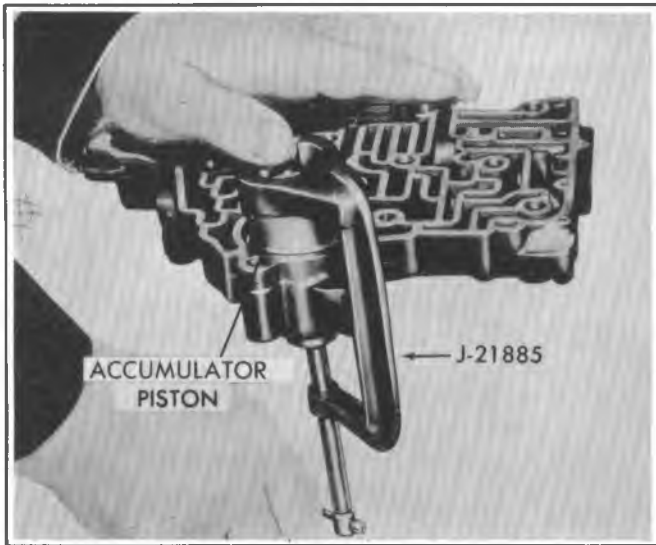

Figure 400-54 Removing Front Accumulator Piston

**NOTICE:** Hold hand over bore when removing retainer pin as 3-2 valve spring may force bore plug out.

8. Remove bore plug, 3-2 valve spring, spacer and 3-2 valve from lower right bore.

9. Using pin punch, remove retainer pin from upper left bore by pressing on outer side of valve body.

**NOTICE:** HOLD HAND OVER BORE WHEN REMOVING RETAINER PIN AS DETENT REGULATOR VALVE SPRING MAY FORCE OTHER COMPONENTS OUT OF BORE.

10. Remove bore plug, detent valve, detent regulator valve, spacer and detent regulator valve spring from upper left bore.

11. Remove grooved retaining pin from lower left bore by prying out with long nose pliers.

12. a. On all models except AD, AE, AH and AL, remove bore plug, 1-2 accumulator valve and primary spring from lower left bore.

b. On AD and AE models remove bore plug, 1-2 accumulator secondary spring and 1-2 accumulator valve from lower left bore.

### Inspection

Do not remove the teflon oil seal from the front accumulator piston unless the oil seal ring requires replacement. The service oil seal ring is cast iron, **Figure 400-55**.

The type of front accumulator piston used in 1971 thru 1980 is not interchangeable with pre-1971 piston.

1. Wash control valve body, valves, and other parts in clean solvent.

**NOTICE:** Do not allow valves to bump together, as this might cause nicks and burrs.

2. Inspect all valves and bushings carefully to make sure that they are free from dirt and are not damaged in any respect. If burrs are present, they should be removed with



Figure 400-55 Front Accumulator Disassembled View

a fine stone or fine grade of crocus cloth and light oil. Be careful not to round off shoulders of valves.

3. All valves and bushings should be tested in their individual bores to make certain that free movement can be obtained. All valves should fall freely of their own weight with a slight tapping action on the body. In checking, be careful to prevent valve damage in any way.

4. The manual valve is the only valve that can be serviced separately. If other valves are malfunctioning or damaged beyond repair, a new control valve assembly should be installed.

5. Inspect body for cracks or scored bores.

6. Check all springs for distortion or collapsed coils.

7. Inspect front accumulator piston and oil ring for damage.

Refer to **Figure 400-19** for identification of control valve passages.

### Assembly

1. Position front accumulator spring and piston into valve body.

2. Install Control Valve Accumulator Piston Installer, J-21885, or J-22269-01, on piston. Compress spring and piston, aligning spring and piston with bore, **Figure 400-54**.

**NOTICE:** Make certain that piston pin is correctly aligned with hole in piston and that oil seal ring does not catch on lip of bore when installing piston.

3. Secure piston and spring with E-ring retainer and remove Installer, J-21885 or J-22269-01.

4. Install the 1-2 accumulator valve train into lower left hand bore, **Figure 400-53**. Models AA, AE, AH, AC and AM.

a. Install the 1-2 accumulator spring and 1-2 accumulator valve, stem end out, into bore. Place the bore plug into valve bore and install grooved retaining pin from the cast surface side of the valve body, with the grooves entering the pin hole last. Tap pin with a hammer until flush with cast surface of valve body.



b. (Model AD) install the 1-2 accumulator valve, stem end out, and 1-2 accumulator secondary spring. Install the bore plug and compress spring until grooved retaining pin can be unseated from the cast surface of the valve body. Install retaining pin with the grooved end entering the pin hole last and tap in place until flush with cast surface of the valve body.

5. Insert spacer inside of detent regulator valve spring and install spring and spacer into upper left bore, making certain spring seats in bottom of bore.

6. Compress detent regulator valve spring and hold with a small screwdriver placed between end of spring and wall on cored side of valve body.

7. Install detent regulator valve, stem end out, and detent valve, small land first, into upper left bore.

8. Insert bore plug, hole out, into upper left bore and, pressing inward on bore plug, remove screwdriver and install retaining pin from cored side of valve body.

9. Install 3-2 valve in bottom right bore.

10. Insert spacer inside of 3-2 valve spring and install spring and spacer in bottom right bore.

11. Compressing 3-2 valve spring, install bore plug, hole end out, and secure with retaining pin from cored side of valve body.

12. Install 3-2 intermediate spring in open end of 2-3 shift valve, and install valve and spring, valve first, into center right bore. Make certain valve seats in bottom of bore.

13. Install 2-3 modulator valve, hole end first, into 2-3 modulator bushing and install both parts in center right bore.

14. Install 2-3 shift valve spring into hole in 2-3 modulator valve, and compressing spring, secure with retaining pin from cored side of control valve.

15. Install 1-2 shift valve, stem end out, in upper right bore, making certain valve seats in bottom of bore.

16. Install 1-2 regulator valve, larger stem first, spring and 1-2 detent valve, hole end first, into 1-2 bushing, and install in upper right bore of control valve body.

17. Compress bushing against spring and secure with retaining pin from cored side of control valve body.

18. Install manual valve with detent pin groove to the right.

## REAR SERVO ASSEMBLY

### Disassembly

1. Remove rear accumulator piston from rear servo piston. See Figure 400-56.
2. Remove E-ring retaining rear servo piston to band apply pin.
3. Remove rear servo piston and seal from band apply pin.
4. Remove washer, spring and retainer.

### Inspection

1. Check freeness of oil seal rings in piston grooves.

See Figure 400-57. Do not remove the teflon oil seal rings from the rear accumulator piston, unless the oil seal rings require replacement.

If the teflon inner oil seal ring, (small diameter) requires replacement, for service, use the aluminum oil seal ring.

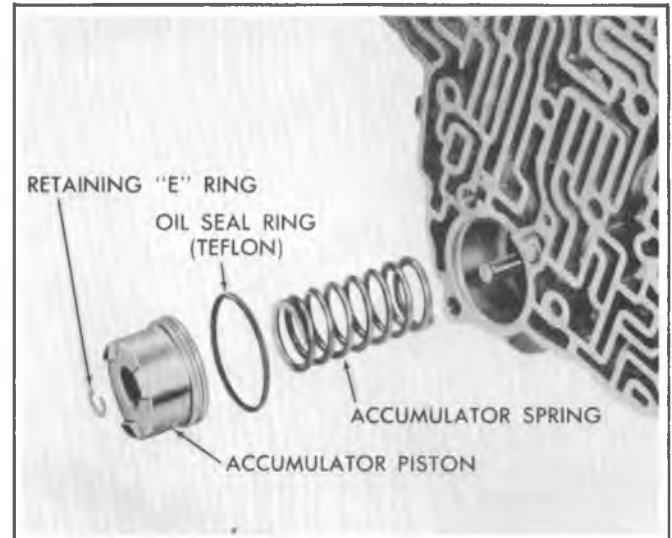

Figure 400-56 Disassembling Rear Servo and Accumulator Piston

The rear accumulator piston, large diameter ring groove depth, is machined shallower to take the large teflon oil seal ring, if this requires replacement, use only the teflon oil seal ring.

2. Inspect fit of band apply pin in servo piston.
3. Inspect band apply pin for scores or cracks.
4. Inspect band apply pin for proper size as determined by pin selection check.

### Assembly

1. Install spring retainer with cup side toward band apply servo pin, spring and washer on servo pin.
2. Install servo piston on pin and secure with E-ring retainer.
3. If removed, install oil seal ring on servo piston.
4. If removed, install outer and inner oil rings on accumulator piston.
5. Install accumulator piston into bore of servo piston.

## FRONT SERVO ASSEMBLY

See Figure 400-58. Do not remove the teflon oil seal ring from the front servo piston unless the oil seal ring requires replacement. The service oil seal ring is aluminum.

The spring retainer, servo pin, retainer ring and servo piston are identical for 1971 thru 1980 transmissions. These individual parts are not interchangeable with the pre-1971 parts.

### Inspection

1. Inspect servo pin for damage.
2. Inspect piston and oil seal ring for damaged oil ring groove, check freedom of ring in groove.
3. Inspect piston for cracks or porosity.
4. Check fit of servo pin in piston.

### Assembly

1. Reassemble parts of front servo, making sure tapered end of servo pin is pointing through the spring and spring retainer. Make sure the retainer ring is in the servo pin groove.



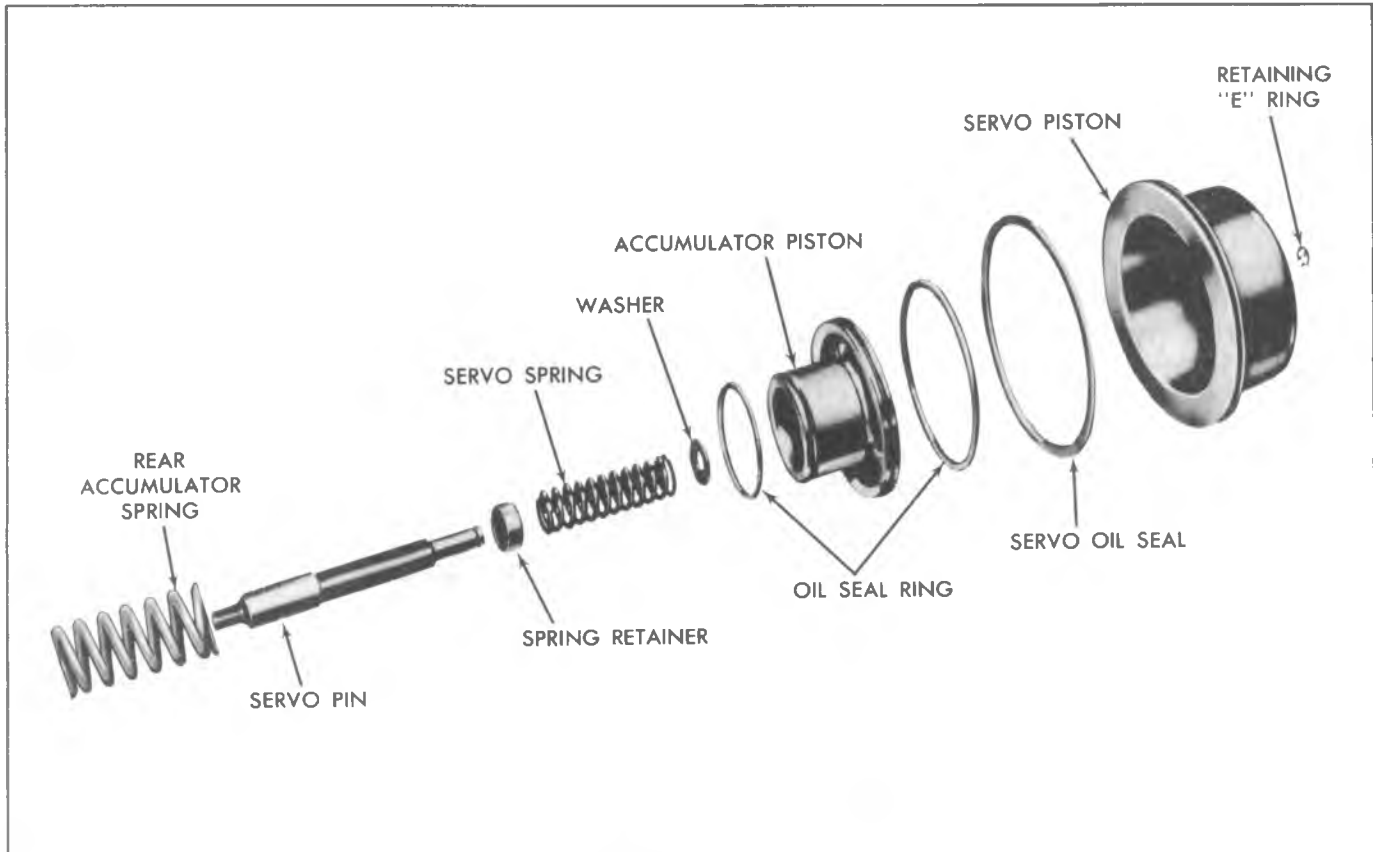

Figure400-57 Rear Servo and Accumulator

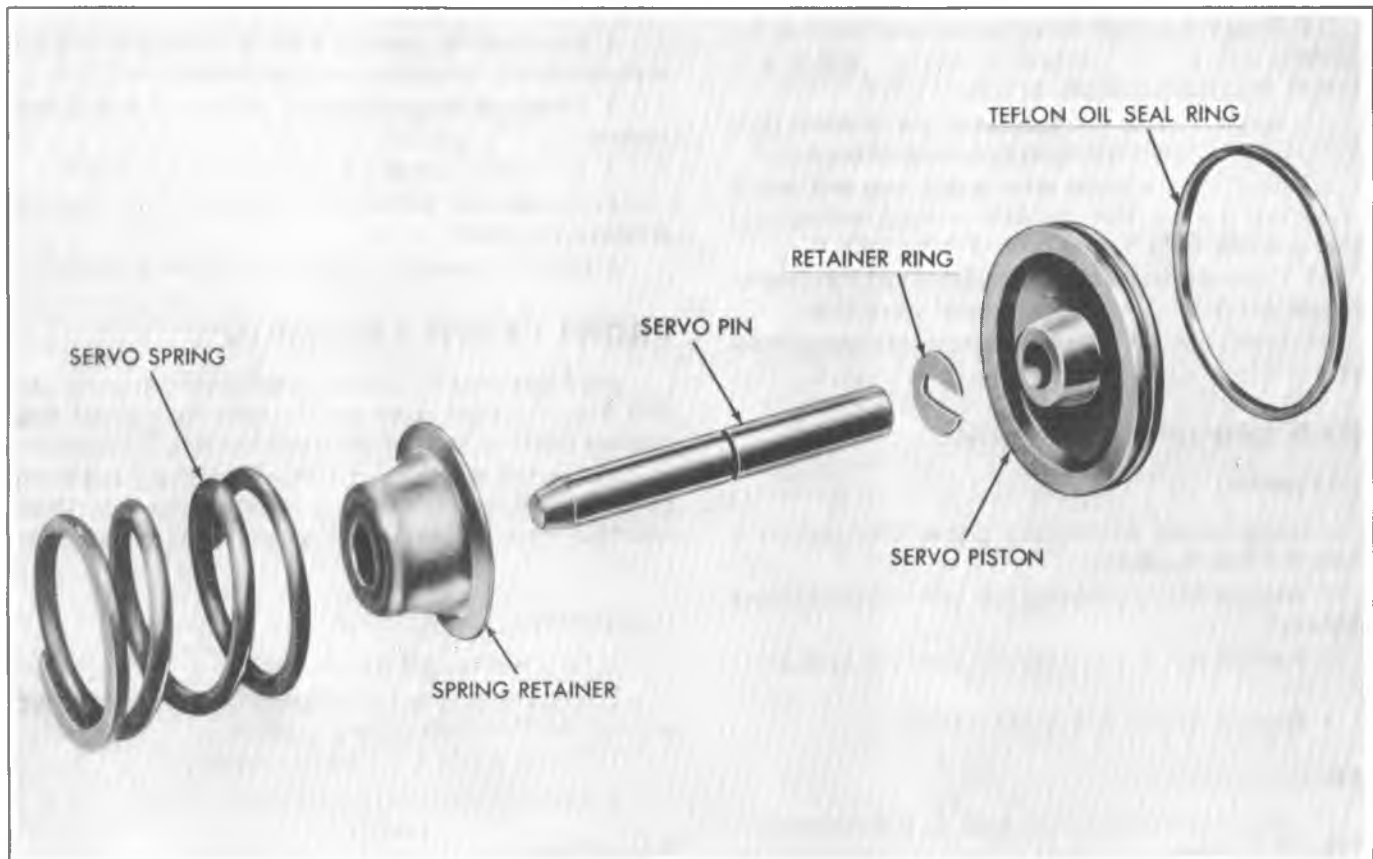

Figure400-58 Front Servo

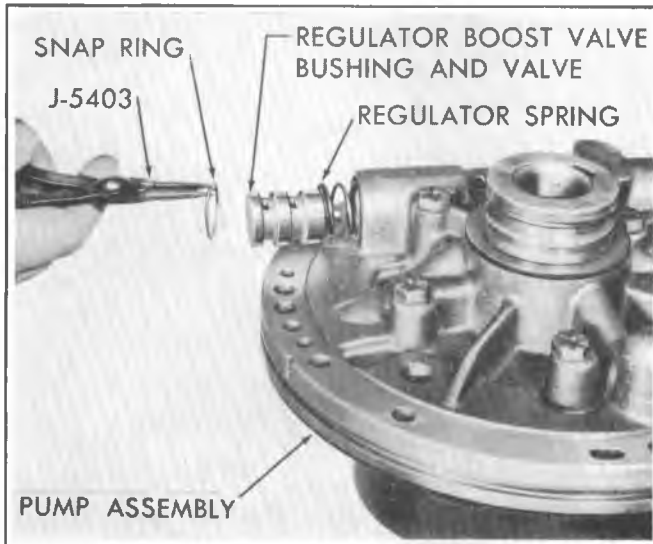

Figure 400-59 Removing Pressure Regulator Valve Snap Ring

## OIL PUMP ASSEMBLY

### Disassembly

1. Using Adapter, J-21364, in Rear Unit Holding Fixture, J-6116, place pump assembly in Holding Fixture with stator shaft pointing downward. Be careful not to damage shaft.

2. Compress regulator boost valve bushing against pressure regulator spring and remove snap ring using Snap Ring Pliers J-5403 (#21), **Figure 400-59**.

**NOTICE: PRESSURE REGULATOR SPRING IS TIGHTLY COMPRESSED**

3. Remove regulator boost valve bushing and valve.

4. Remove pressure regulator spring.

5. Remove regulator valve, spring retainer, and spacer or spacers if present.

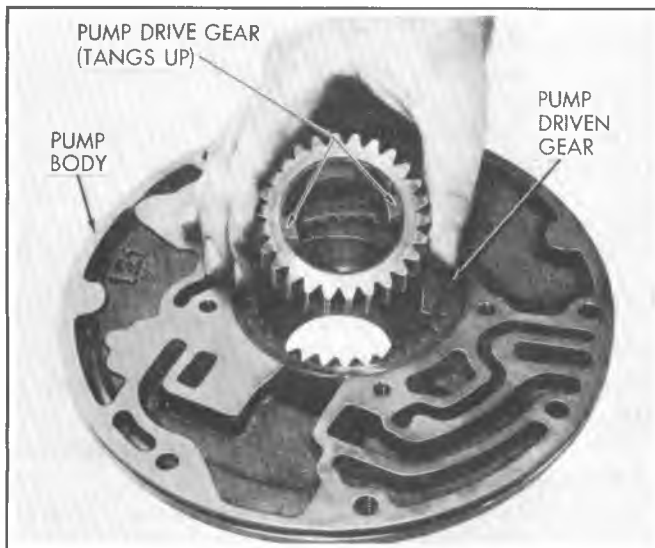

Figure 400-60 Removing Pump Gears

6. Remove five pump cover attaching screws and remove pump cover from body.

7. Mark drive and driven gears for reassembly in same position and remove from pump body, **Figure 400-60**.

Installing the gears in the same position as removed, will assure the quietest operation, as the gear teeth will mesh in the established wear pattern.

8. Remove retaining pin and bore plug from end of regulator bore.

9. Remove two oil rings from pump cover.

10. Remove pump to forward clutch housing selective washer.

11. If necessary to replace front oil seal, pry seal from pump body, **Figure 400-26**.

### Inspection of Pump Body

1. Inspect gear pockets and crescent for scoring, galling or other damage.

2. Place pump gears in pump body and check pump body face to gear face clearance. Clearance should be .02 mm-.09 mm (.0008 inch-.0035 inch), **Figure 400-61**.



Figure 400-61 Pump Body Face to Gear Face Clearance

3. Check face of pump body for scores or nicks.

4. Check oil passages for proper opening and lack of porosity.

5. Check for damaged cover bolt attaching threads.

6. Check for overall flatness of pump body face.

7. Check bushing for scores or nicks.

### Inspection of Pump Cover

1. Inspect pump cover face, **Figure 400-62**, for overall flatness.

2. Check for scores or dirt in pressure regulator bore.

3. Make certain all passages are open and not interconnected through porosity.

4. Check for scoring or damage at pump gear face.

5. Inspect stator shaft for damaged splines, or scored bushings.

6. Inspect oil ring grooves for damage or wear.

7. Inspect selective thrust washer face for wear or damage.

8. Inspect oil seal ring on pump body and remove if necessary.

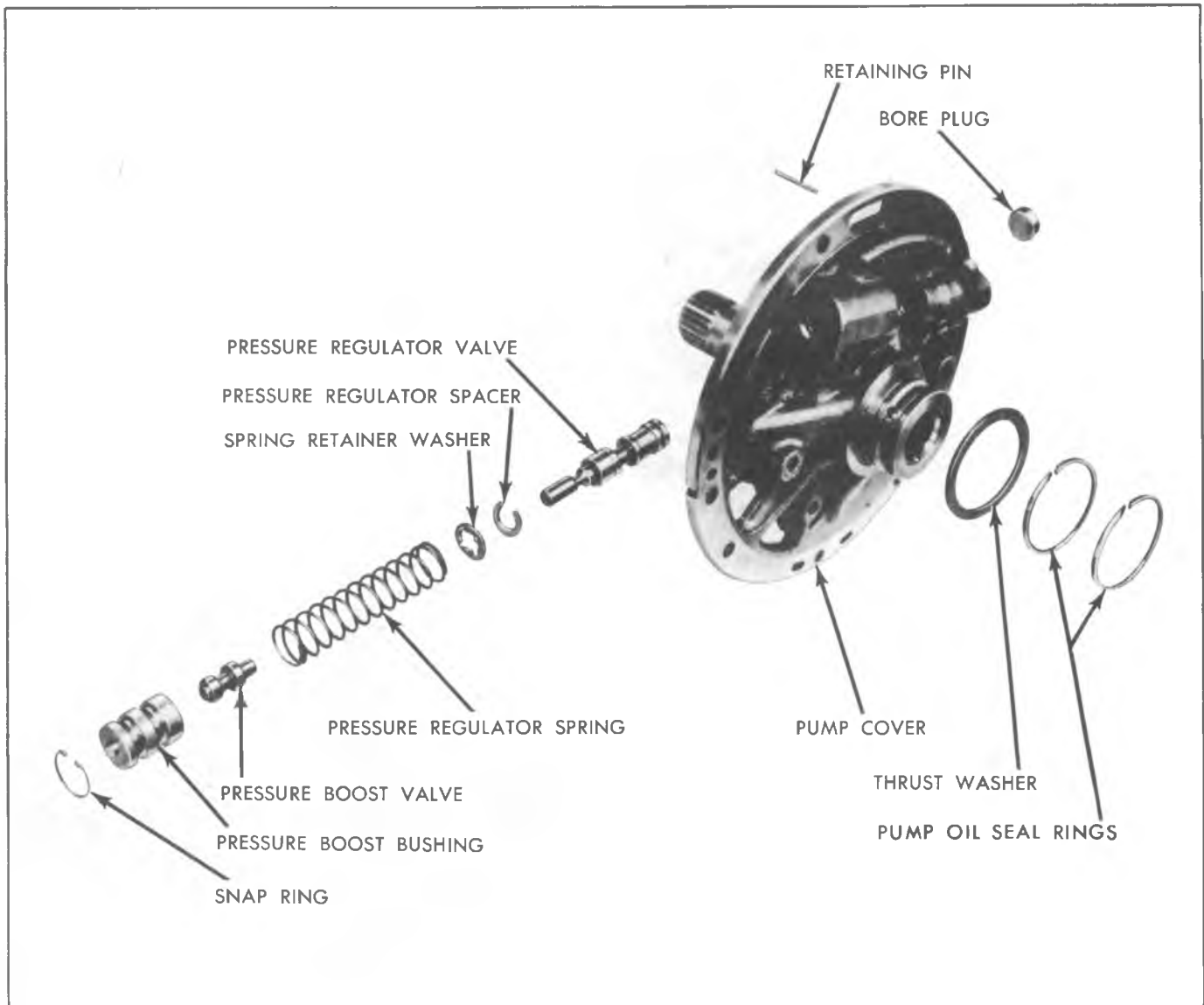

Figure 400-62 Pump Cover Disassembled View

9. Inspect pressure regulator and boost valve for free operation.

The solid type pressure regulator valve does not contain oil holes and an orifice cup plug like the previous pressure regulator valve. The solid style valve must only be used in the pump cover with the squared off pressure regulator boss, (Pressure boost bushing end). The previous pressure regulator valve with the oil holes and orifice cup plug will be used to service either type pump cover.

10. Inspect pump cover for open 1/8 inch diameter breather hole. See **Figure 400-24**.

### Assembly

1. Install drive and driven pump gears into pump body with alignment marks up and mated. In this position the pump gear drive tangs will also be up.

2. Install pressure regulator spacer or spacers, if required, spring retainer and spring into pressure regulator bore.

3. Install boost valve into bushing, stem end out, and install both parts into pump cover by compressing bushing against spring.

4. Install retaining snap ring.

5. Install pressure regulator valve from opposite end of bore, stem end first.

6. Install pressure regulator valve bore plug and retaining pin into end of bore.

7. Install previously selected front unit selective thrust washer over pump cover delivery sleeve.

Proper washer size was determined at time of front unit end play check.

8. Install two oil seal rings. Be sure the lap joint is properly installed.

9. Place pump body in Rear Unit Holding Fixture, J-6116, with gasket surface facing up.

10. Lubricate pump gears with transmission fluid and install pump cover on pump body.

11. Install pump cover attaching screws following screw chart, **Figure 400-63**. Leave screws one turn loose at this time.

12. Install pump body and Cover Alignment Band, J-21368, around pump assembly. Tighten wing nut on alignment band to align pump cover with pump body, **Figure 400-64**.

13. Tighten pump cover attaching screws to 24 N·m (18 foot-pounds) and remove alignment band from pump.

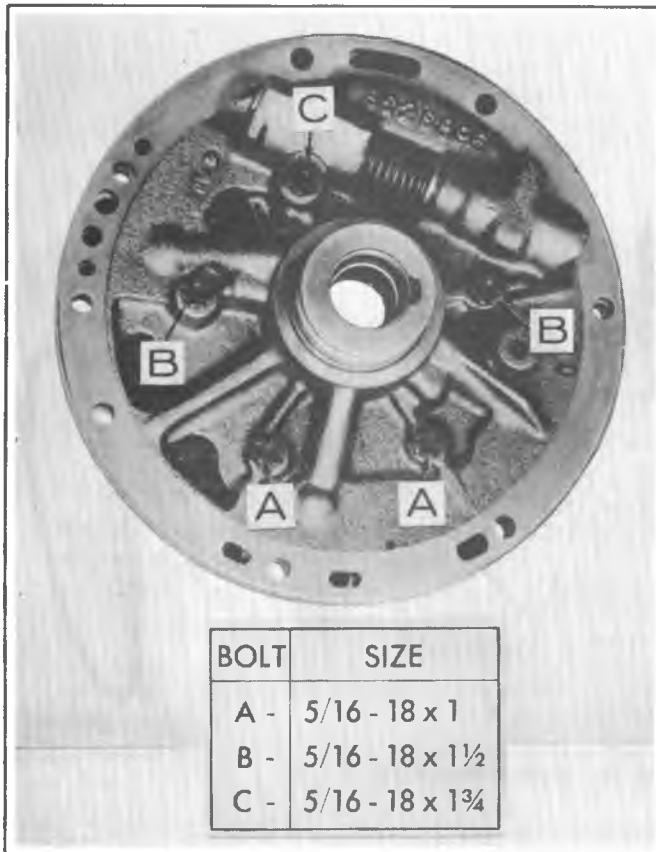

Figure 400-63 Pump Cover Attaching Screws



Figure 400-64 Aligning Pump Cover and Body

14. Install new square cut O-ring on pump.

15. If necessary, install new pump oil seal using pump Oil Seal Installer, J-21359, Figure 400-27.

## FORWARD CLUTCH ASSEMBLY - DISASSEMBLY

### Disassembly

1. Using Adapter, J-21364, in Rear Unit Holding Fixture, J-6116-01, place forward clutch assembly in Holding Fixture with turbine shaft pointing downward. Be careful not to damage shaft.

2. Remove forward clutch housing to direct clutch hub snap ring.

3. Remove direct clutch hub.

4. Remove forward clutch hub and one thrust washer from each side of hub, Figure 400-65.

5. Remove composition and steel clutch plates as shown on Figure 400-65.

6. Place forward clutch assembly in arbor press with turbine shaft pointing downward.

7. Using Clutch Spring Compressor, J-4670-01, and Adapter, J-21664, compress spring retainer with arbor press and remove snap ring using Snap Ring Pliers, J-8059 or J-5586, Figure 400-66.

8. Remove tools, spring retainer and 16 clutch release springs. Keep springs separate from direct clutch springs.

9. Remove forward clutch piston from forward clutch housing.

10. Remove inner and outer seals from clutch piston.

11. Remove center piston seal from forward clutch housing.

12. It is not necessary to remove turbine shaft from forward clutch housing unless either shaft or housing is damaged and must be replaced. In such case proceed as follows:

a. Place forward clutch housing in arbor press with turbine shaft pointing downward.

b. Using 3/8 inch drive extension approximately 3 inches long, or similar tool as driver, press turbine shaft out of forward clutch housing.

### Inspection

1. Inspect composition faced and steel clutch plates for signs of burning, scoring or wear.

2. Inspect sixteen release springs for collapsed coils or signs of distortion.

3. Inspect clutch hubs for worn splines, proper lubrication holes, and thrust faces.

4. Inspect piston for cracks.

5. Inspect clutch housing for wear, scoring, cracks and open oil passages.

6. Inspect operation of ball check in forward clutch housing.

7. Inspect turbine shaft for open lubrication passages at each end.

8. Inspect turbine shaft splines for damage.

9. Inspect bushing journals for damage.

10. Inspect turbine shaft for cracks or distortion.

### Assembly

1. If turbine shaft was previously removed from forward clutch housing proceed as follows:

a. Place forward clutch housing on arbor press with flat side up.

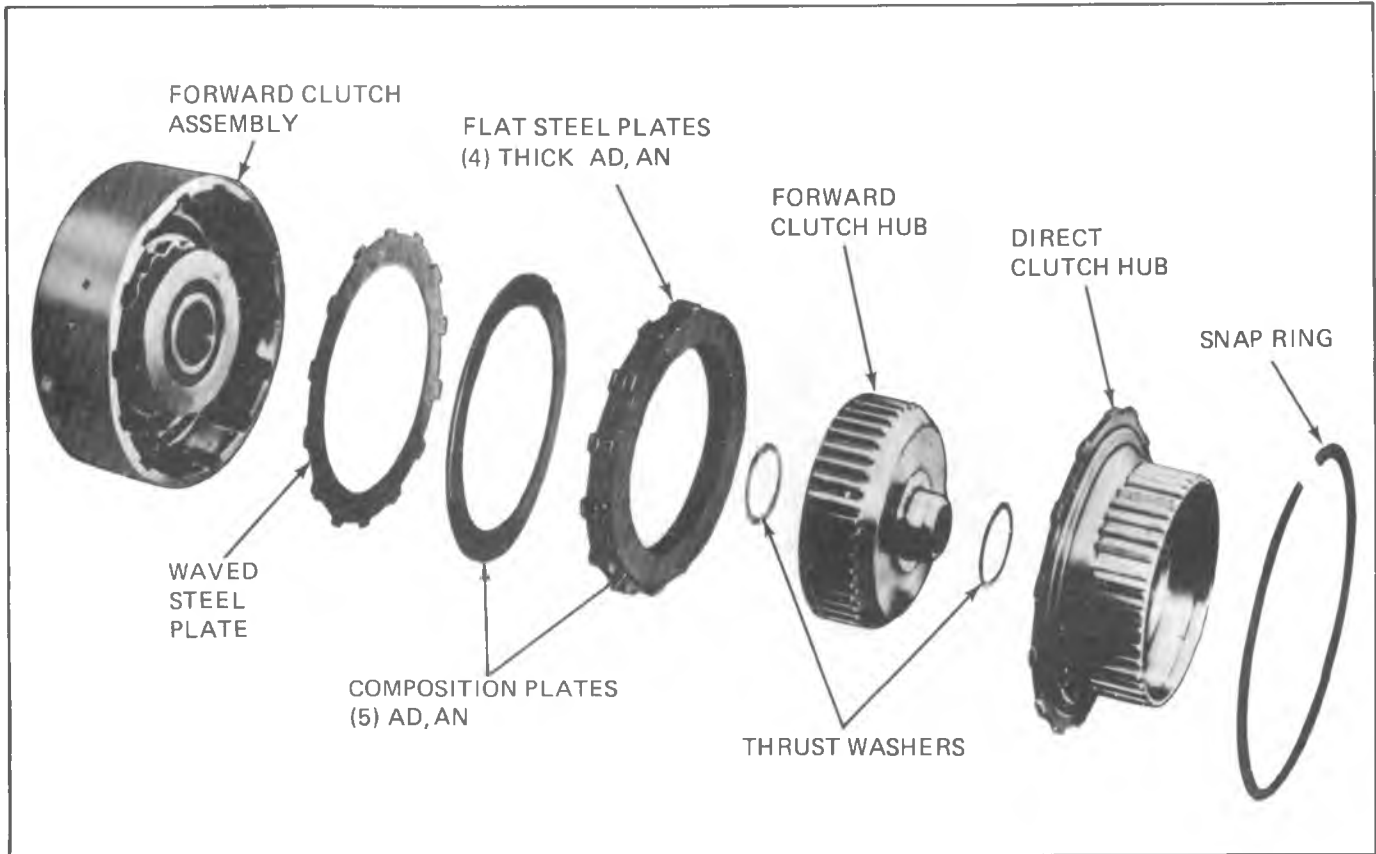

Figure400-65 Forward Clutch Assembly - Disassembled View

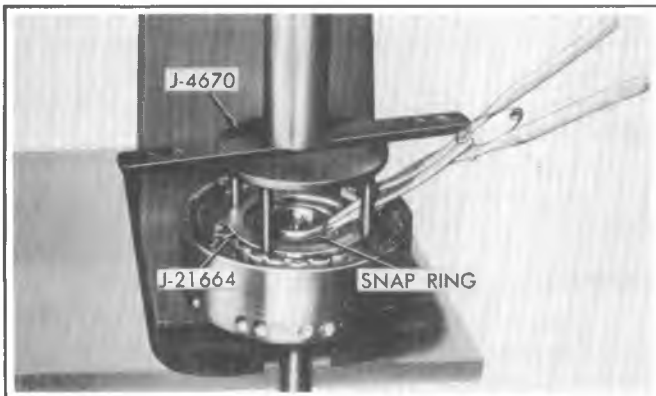

Figure400-66 Removing Forward Clutch Snap Ring

b. Align shorter splined end of turbine shaft with splines in forward clutch housing, and using arbor press, carefully press shaft into housing until shaft bottoms on hub of housing.

**NOTICE:** Start shaft into housing and back off on arbor press to allow shaft to straighten itself. Repeat this step several times until you are certain shaft is going in straight, otherwise, shaft or housing splines may be damaged.

2. Invert forward clutch housing on arbor press with turbine shaft pointing downward.

3. Lubricate new inner and outer clutch piston seals with transmission fluid. Lubricate seal grooves in forward

clutch piston with petrolatum and install seals with lips facing away from spring pockets.

4. Lubricate new center piston seal with transmission fluid. Lubricate seal groove in forward clutch housing with petrolatum and piston seal with transmission fluid. Lubricate seal groove in forward clutch housing with petrolatum and install seal into clutch housing with lip facing up.

5. Place Forward and Direct Clutch Inner Seal Protector, J-21362, over forward clutch hub. Install clutch piston inside Forward and Direct Clutch Piston Installer, J-21409. Insert assembly in forward clutch housing. **Figure 400-67**, and install clutch piston by rotating it slightly in a clockwise direction until seated.

6. Install sixteen clutch release springs into spring pockets in clutch piston.

7. Using Clutch Spring Compressor, J-4670-01, and Adapter, J-21664, compress spring retainer with arbor press, being careful that retainer does not catch in snap ring groove, and install snap ring using Snap Ring Pliers, J-8059 or J-5586, **Figure 400-66**. Remove tools.

Make certain clutch release springs are not leaning. If necessary, straighten with a small screwdriver.

8. Remove forward clutch assembly from arbor press and place in Holding Fixture, J-6116-01, with turbine shaft pointing down. Be careful not to damage shaft.

9. Install thrust washer on the outside of forward clutch hub. The bronze washer is installed on side of hub facing forward clutch housing.

10. Install forward clutch hub in forward clutch housing.

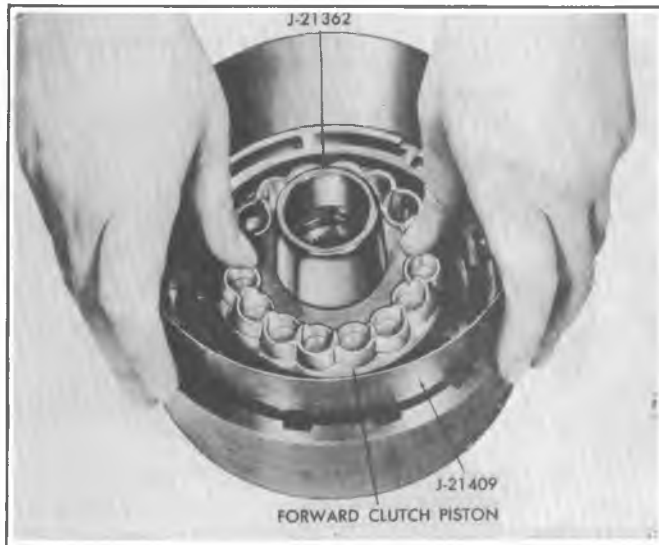

Figure 400-67 Installing Forward Clutch Piston

11. a. Models AA, AB, AC, AE, AH lubricate and install one (1) waved steel (plate with "U" notch) three (3) thin flat steel (.077" thick) and four (4) composition-faced plates, starting with the waved plate and alternating flat steel and composition-faced plates.

b. Models AD, AM, lubricate and install one (1) waved steel (plate with "U" notch), four (4) thick flat steel (.091" thick) and five (5) composition-faced plates, starting with the waved plate and alternating flat steel and composition-faced plates.

12. Install direct clutch hub in forward clutch housing over clutch plates, and install snap ring.

13. Place forward clutch housing on pump delivery sleeve and air check clutch operation by applying air through forward clutch passage in pump, **Figure 400-68** to actuate piston and move forward clutch.

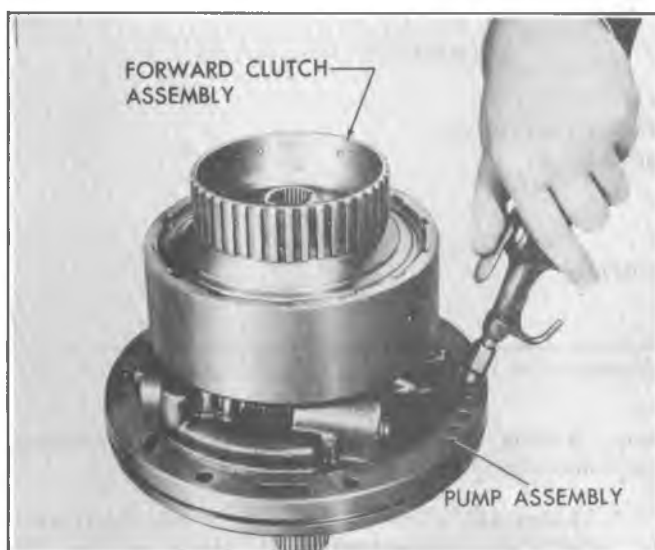

Figure 400-68 Air Checking Forward Clutch

## DIRECT CLUTCH AND INTERMEDIATE ROLLER ASSEMBLY

### Disassembly

1. Remove roller retainer snap ring, and remove clutch retainer.

2. Remove roller outer race and remove roller assembly. See **Figure 400-69**.

3. Turn unit over and remove direct clutch backing plate to clutch housing snap ring.

4. Remove direct clutch backing plate and composition and steel clutch plates as shown on **Figure 400-70**.

5. Using Clutch Spring Compressor, J-4670, Rear Clutch Spring Compressor, J-6129, or an arbor press, and Adapter J-21664. **Figure 400-72** compress spring retainer and remove snap ring with Snap Ring Pliers, J-8059 or J-5586.

6. Remove tools, spring retainer and 14 clutch release springs. Keep springs separate from forward clutch springs, **Figure 400-71**.

7. Remove direct clutch piston from direct clutch housing.

8. Remove inner and outer seals from clutch piston.

9. Remove center piston seal from direct clutch housing.

### Inspection

1. Inspect roller clutch assembly for damaged rollers, cage or springs.

2. Inspect cam and outer race for scratches or wear.

3. Inspect clutch housing for cracks, wear, proper opening of oil passages and wear on clutch plate drive lugs.

4. Inspect composition-faced and steel clutch plates for signs of wear or burning.

5. Inspect backing plate for scratches or other damage.

6. Inspect piston for cracks.

7. Inspect springs for collapsed coils or signs of distortion.

8. Inspect housing for face operation of check ball.

The 14 direct clutch release springs are not serviced individually. If one or more of these springs require replacement, discard all of them and install the 16 service direct clutch release springs.

### Assembly

1. Lubricate new inner and outer clutch piston seals with transmission fluid. Lubricate seal grooves in direct clutch piston and install seals with lips facing away from spring pockets.

2. Lubricate new center seal with transmission fluid. Lubricate seal groove in direct clutch housing and install seal in clutch housing with lip facing up.

3. Place Forward and Direct Clutch Inner Seal Protector, J-21362, over direct clutch hub. Install clutch piston inside Forward and Direct Clutch Piston Installer, J-21409, insert assembly in direct clutch housing, **Figure 400-73**, and install clutch piston by rotating it slightly, in a clockwise direction.

4. Install 14's (16's if service) clutch release springs into spring pockets in clutch piston.

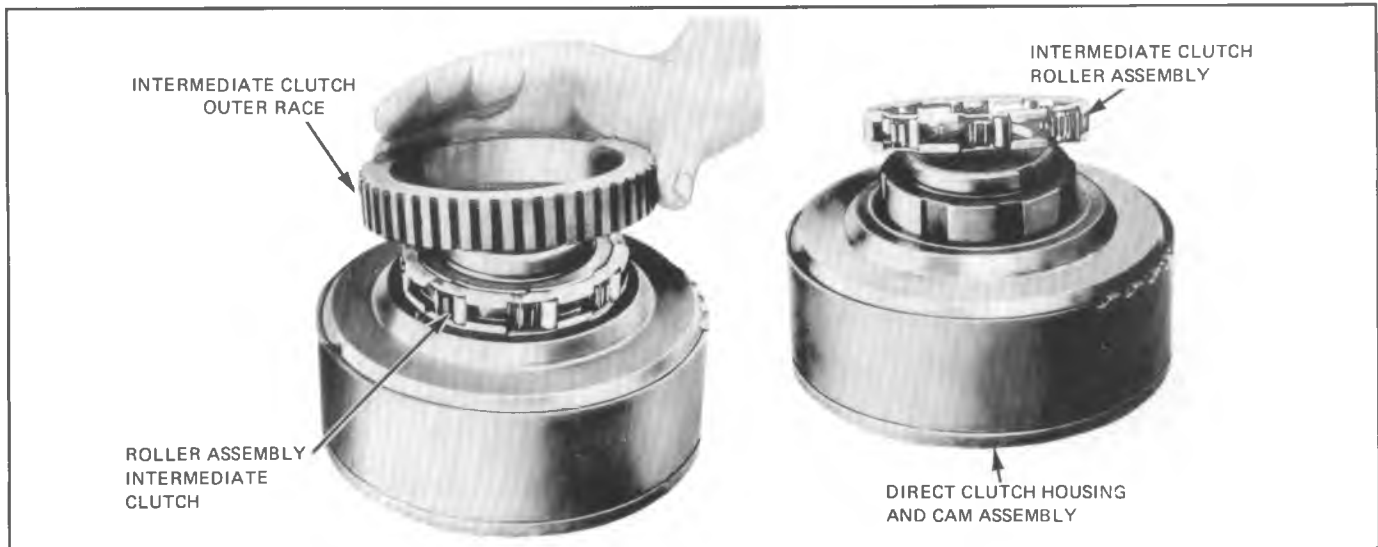

Figure 400-69 Removing Roller Outer Race and Assembly

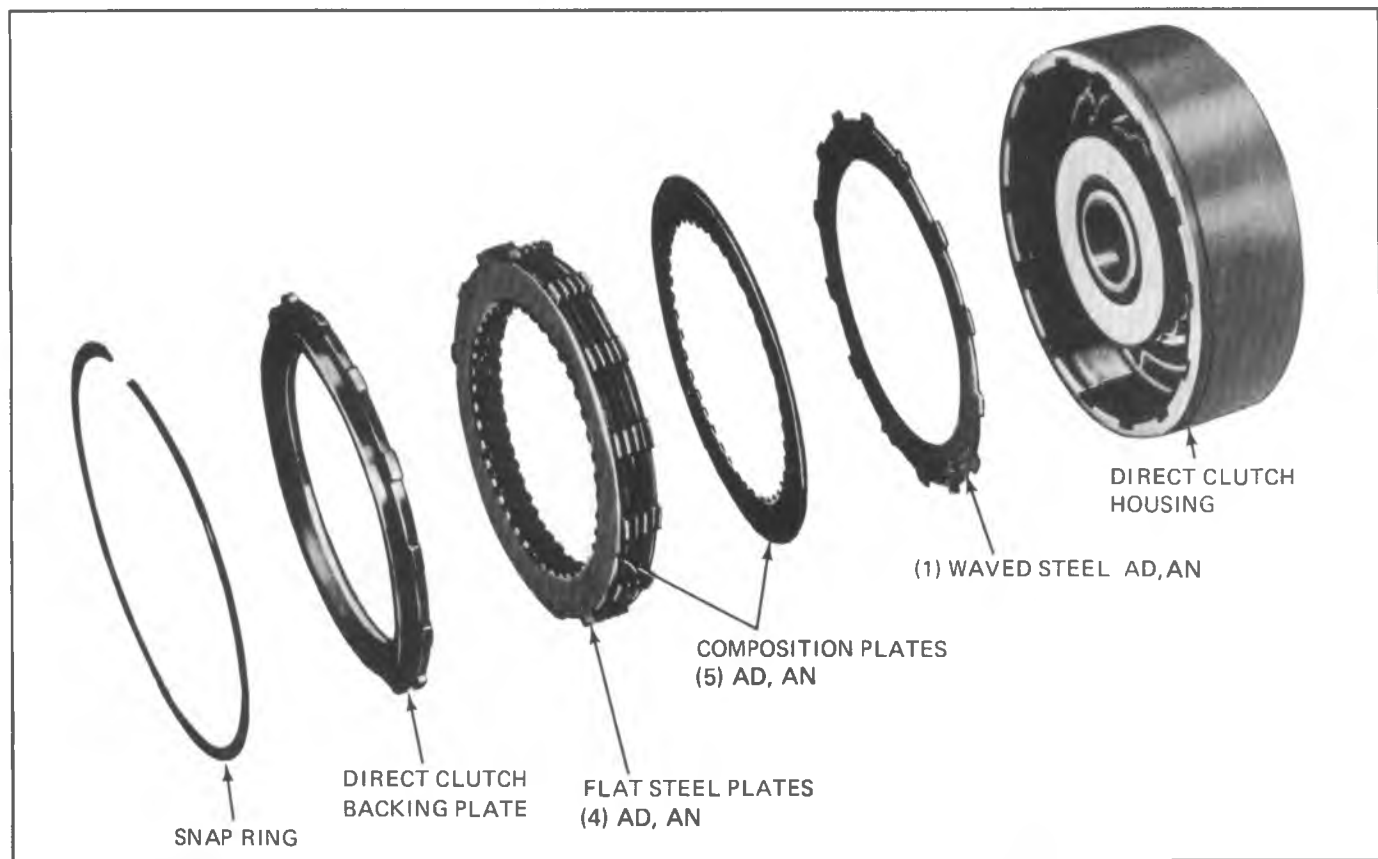

Figure 400-70 Direct Clutch - Disassembled View

5. Place spring retainer and snap ring over springs.

6. Using Clutch Spring Compressor, J-4670-01, Rear Clutch Spring Compressor, J-6129, or an arbor press, and Adapter, J-21664, **Figure 400-72**, compress spring retainer, being careful that retainer does not get caught in snap ring groove, and install snap ring with Snap Ring Pliers, J-8059 or J-5586. Remove tools.

Make certain clutch release springs are not leaning. If necessary, straighten spring with a small screwdriver.

7a. Models AA, AB, AC, AE, AH, oil and install four (4) flat steel (.091" thick) and four (4) composition-faced

plates, starting with a flat steel plate and alternating composition-faced and flat steel clutch plates.

b. Models AD, oil and install one (1) waved (plate with "U" notch), four (4) flat steel (.091" thick) and five (5) composition-faced plates, starting with the waved plate and alternating flat steel and composition-faced clutch plates.

c. Model AM, oil and install six (6) composition-faced plates, starting with a flat steel and alternating composition-faced and flat steel clutch plates.

Do not use radially grooved composition plates here.



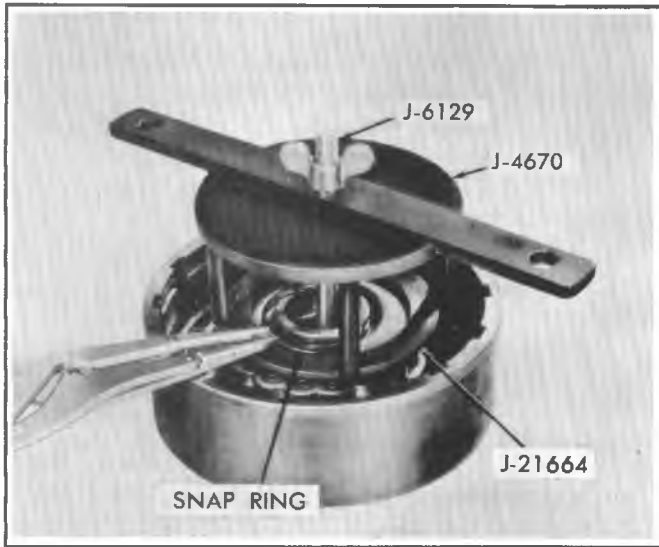

Figure 400-72 Removing Direct Clutch Snap Ring

All direct clutch flat steel plates are .091 in. thick.

8. Install direct clutch backing plate over clutch plates and install backing plate snap ring.

Install rollers that may have come out of the roller cage by compressing the energizing spring with forefinger and inserting the roller from the outer side.

Turn unit over and install the roller clutch assembly onto the intermediate clutch inner cam. Install the intermediate clutch outer race with a clockwise turning motion.

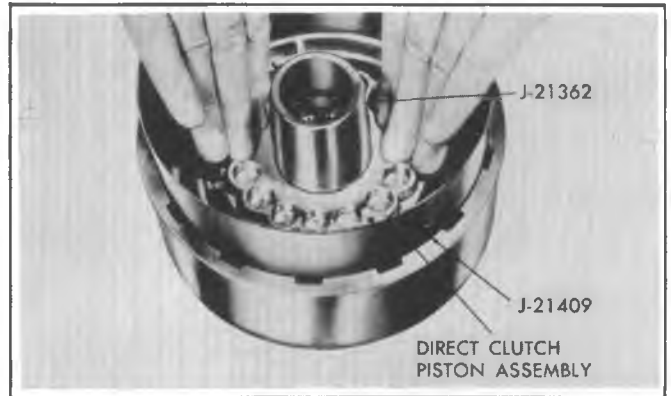

Figure 400-73 Installing Direct Clutch Piston

When installed, outer race should not turn counterclockwise, Figure 400-74.

9. Install roller clutch assembly retainer and snap ring.

10. Place direct clutch assembly on center support and air check operation of direct clutch, Figure 400-75.

If air is applied through reverse passage, (right oil feed hole) it will escape from direct clutch passage (left oil feed hole). This is considered normal. Apply air through left oil feed hole to actuate piston and move direct clutch plates.)

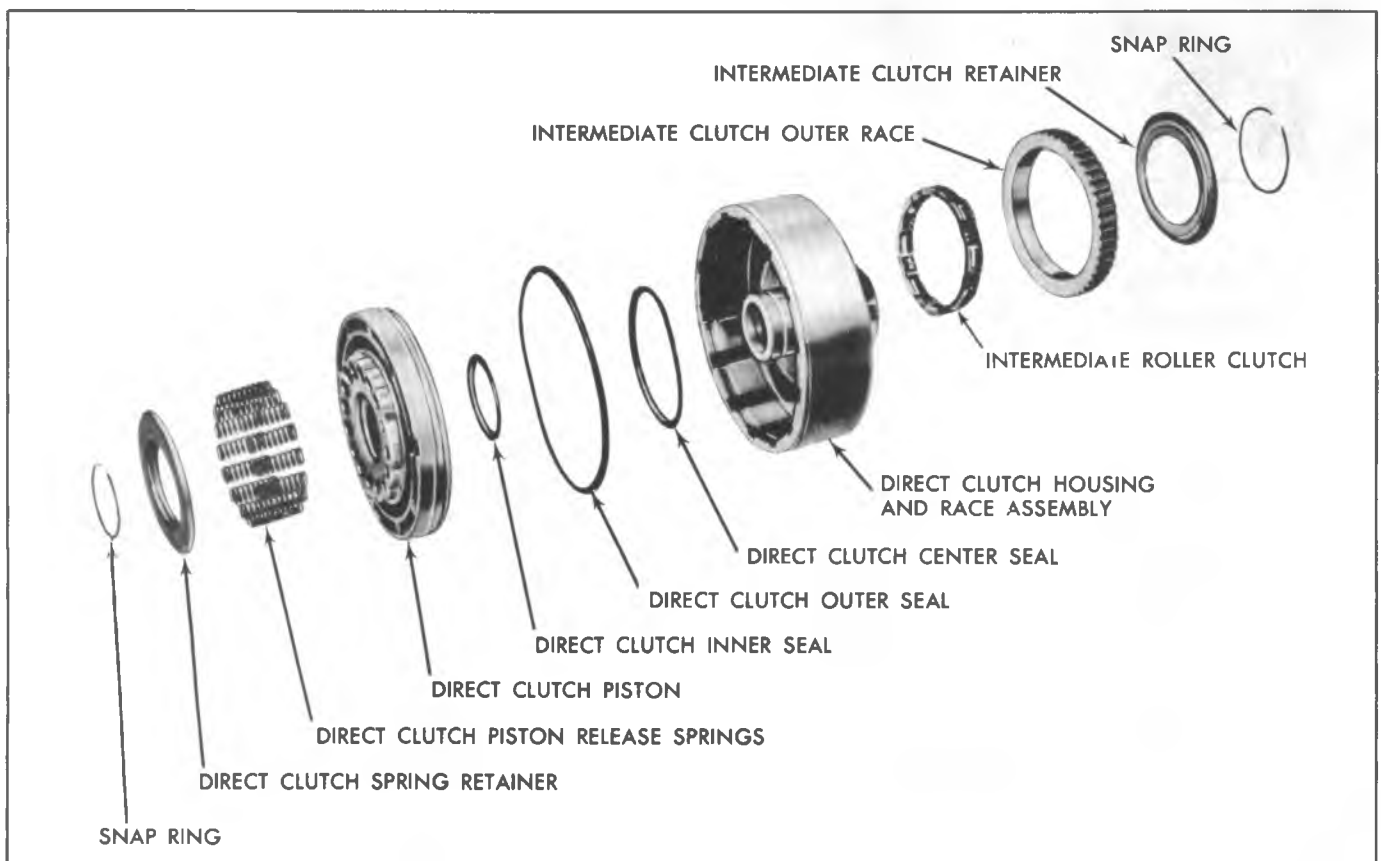

Figure 400-71 Direct Clutch and Piston



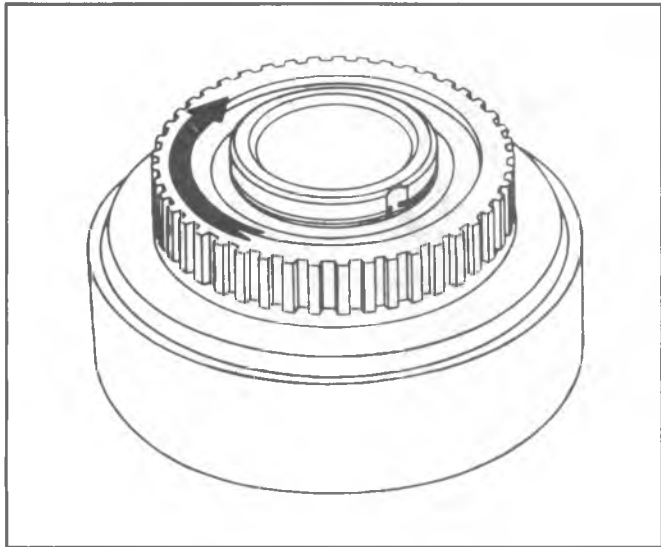

Figure 400-74 Roller Clutch Rotation

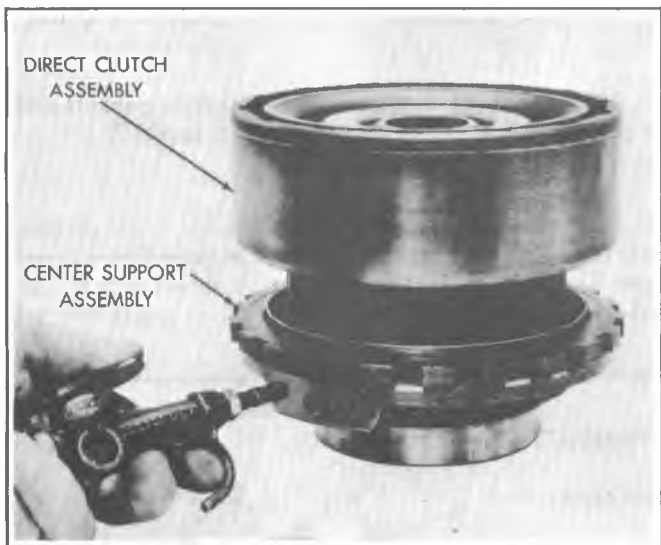

Figure 400-75 Checking Direct Clutch

## CENTER SUPPORT AND INTERMEDIATE CLUTCH PISTON

### Disassembly

1. Remove four oil rings from the center support, **Figure 400-75**.
2. Compress spring retainer and remove snap ring with Snap Ring Pliers, J-8059 or J-5586, **Figure 400-78**.
3. Remove spring retainer and 3 intermediate clutch release springs.
4. Remove spring guide.
5. Remove intermediate clutch piston from center support.
6. Remove inner and outer seals from clutch piston.

Do not remove the three screws retaining roller clutch inner race to center support.

### Inspection

1. Inspect roller clutch inner race for scratches or indentations. Be sure lubrication hole is open.
  2. Inspect bushing for scoring, wear or galling.
  3. Check oil ring grooves for damage.
  4. Air Check oil passages to be sure they are open and not interconnected.
  5. Inspect piston sealing surfaces for scratches.
  6. Inspect piston seal grooves for nicks or other damages.
  7. Inspect piston for cracks.
- Refer to **Figure 400-22** for identification of oil feed passages and lands.
8. Inspect springs for collapsed coils or signs of distortion.
  9. Inspect oil seal rings for damage.
- All service center support oil seal rings are hook type cast iron.
10. Inspect to see that constant bleed orifice (approx. .020) is open, **Figure 400-47**.

### Assembly

1. Lubricate new inner and outer clutch piston seals with transmission fluid. Lubricate seal grooves in intermediate clutch piston and install seals with lips facing away from spring guide, **Figure 400-79**.
2. Place Intermediate Clutch Inner Seal Protector, J-21363, over center support hub, **Figure 400-80**, and install intermediate clutch piston, making certain it fully seats in center support. Remove J-21363.
3. Install plastic spring guide, **Figure 400-81**.
4. Install 3 clutch release springs, space equally into holes in spring guide, **Figure 400-82**.
5. Place spring retainer and snap ring over springs.
6. Compress spring retainer, being careful that retainer does not get caught in snap ring groove, and install snap ring with Snap Ring Pliers, J-8059 or J-5586, **Figure 400-78**.
7. Install four oil seal rings on the center support, **Figure 400-77**.
8. Air check operation of intermediate clutch piston. Apply air through center oil feed hole to actuate clutch pistons, **Figure 400-83**.

## GEAR UNIT

### Disassembly of Gear Unit

1. Using Adapter, J-21364, in Rear Unit Holding Fixture, J-6116-01, place gear unit in Holding Fixture with output shaft pointing downward.
  2. Remove center support to sun gear races and thrust bearing.
- Outer race may have stuck to center support when it was removed.
3. Remove sun gear from output carrier assembly.
  4. Remove reaction carrier to output carrier thrust washer and front internal gear ring.
  5. Invert gear unit in Holding Fixture with main shaft pointing downward.
  6. Remove snap ring securing output shaft to output carrier and remove output shaft. Remove O-ring from output shaft and discard.

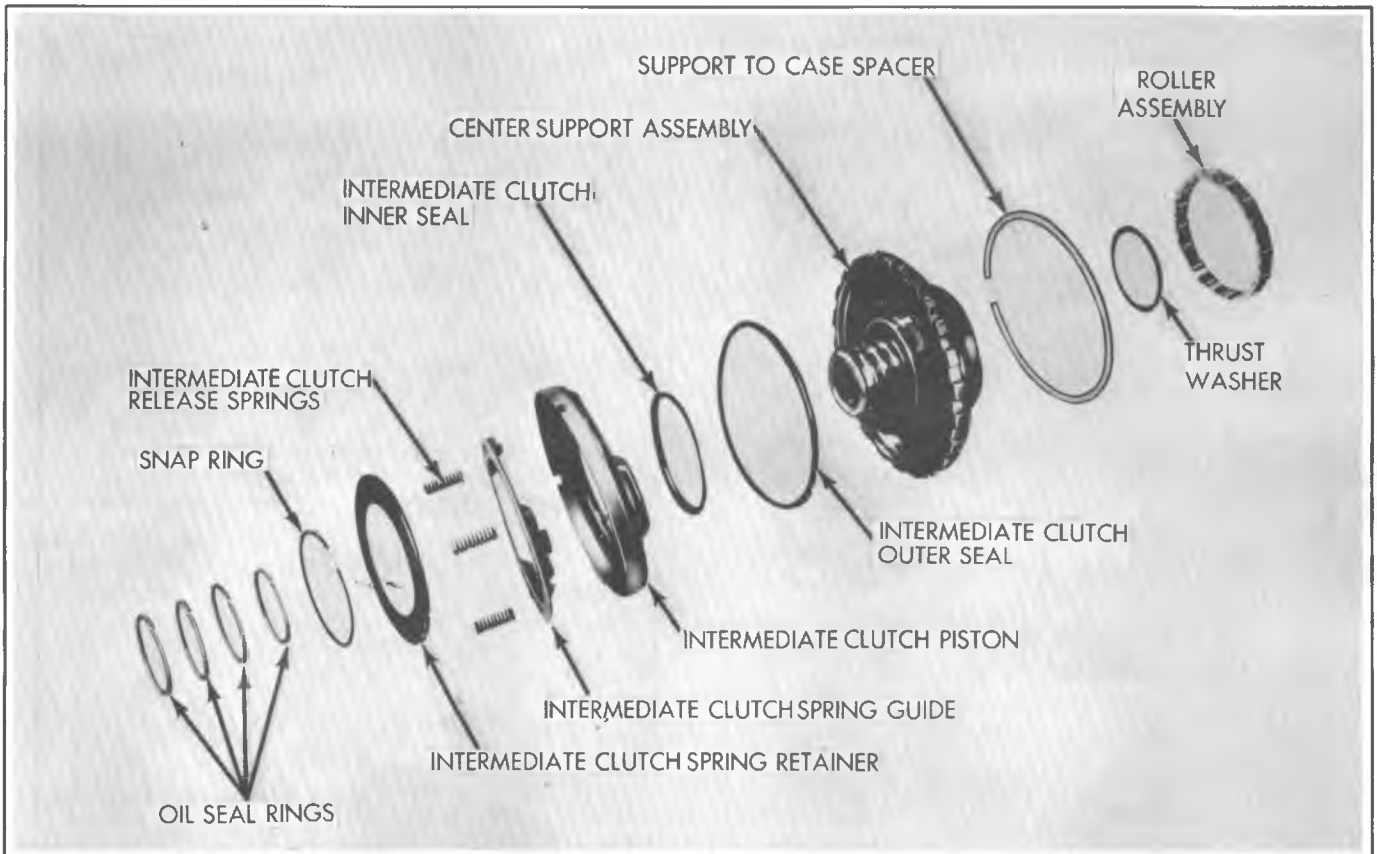

Figure400-76 Center Support Assembly - Disassembled View

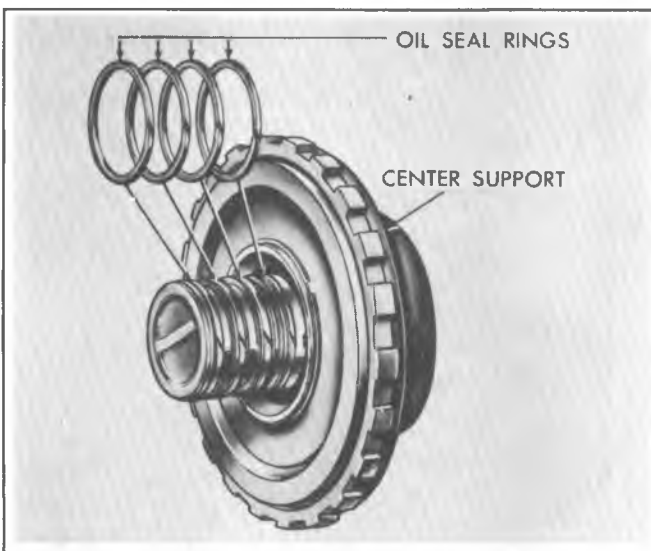

Figure400-77 Center Support Oil Seal Rings



Figure400-78 Removing Intermediate Clutch Snap Ring

7. Remove thrust bearing and races from rear internal gear.
8. Lift rear internal gear and main shaft out of output carrier and remove thrust bearing and races from inner face of rear internal gear.
9. Remove snap ring from end of main shaft and remove rear internal gear.
10. Remove output carrier from Holding Fixture.

**Inspection of Output Shaft**

1. Inspect bushing for wear or galling.

2. Inspect bearing and thrust washer surfaces for damage.
3. Inspect governor drive gear for rough or damaged teeth.
4. Inspect splines for damage.
5. Inspect drive lugs for damage.
6. Inspect speedometer drive gear for rough or damaged teeth. If replacement of drive gear is necessary, proceed as follows.

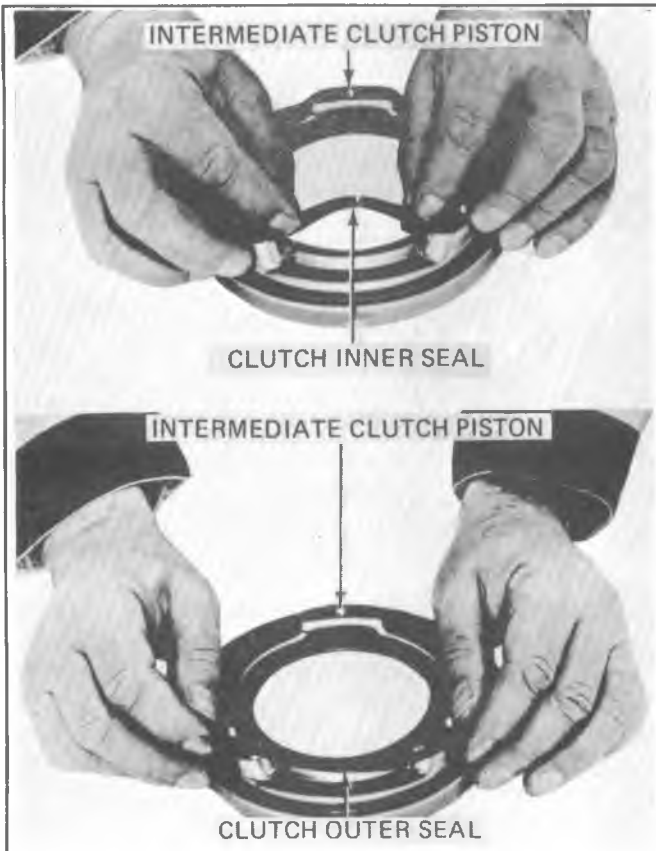

Figure400-79 Installing Intermediate Clutch Piston Seals

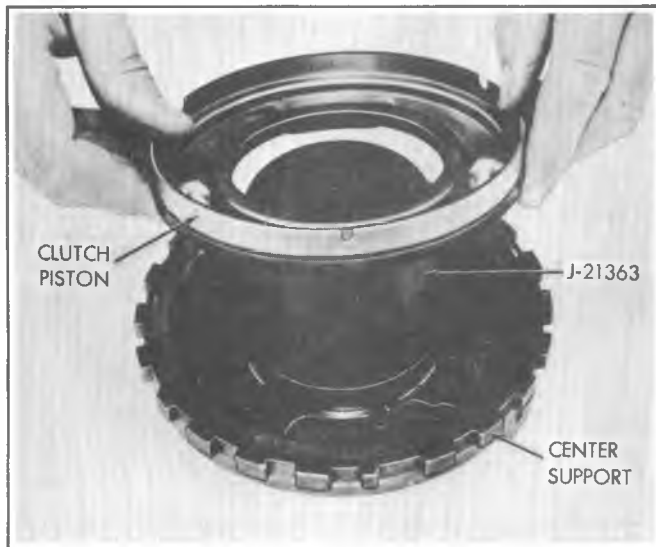

Figure400-80 Installing Intermediate Clutch Piston

### Speedometer Drive Gear Replacement

1. Install Speedometer Drive Gear Remover, J-21427-01, with Pulley Puller, J-8433, and attach on output shaft so that puller bolt indexes with end of shaft and flat face of remover tool is under front face of drive gear.
2. Tighten bolt on Pulley Puller, **Figure 400-93** until gear is free on shaft. Remove tools and gear from shaft.
3. Support output shaft and install new steel speedometer drive gear using a piece of pipe.

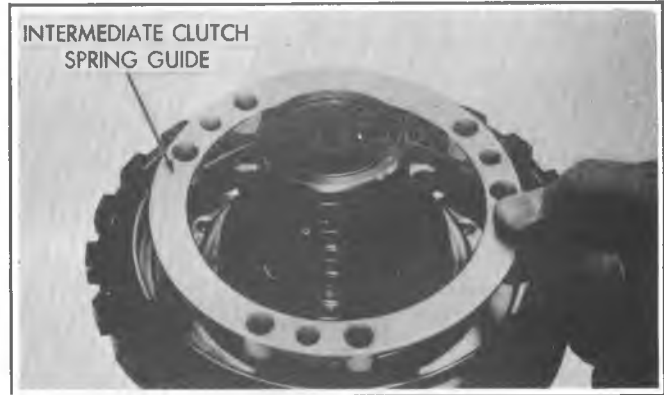

Figure400-81 Installing Spring Guide

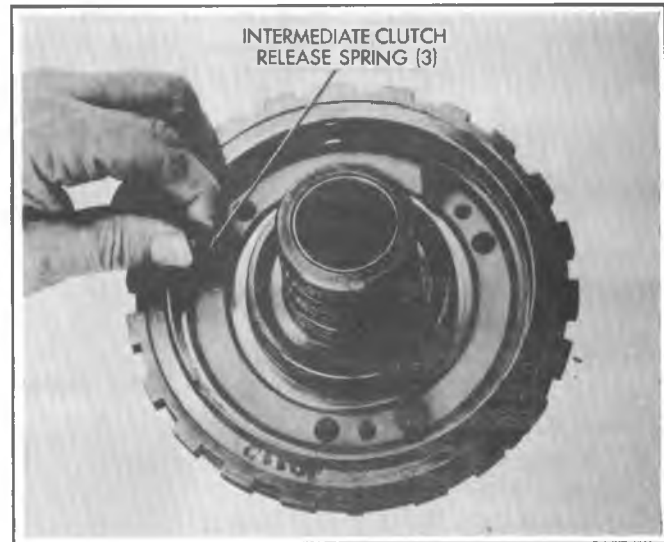

Figure400-82 Installing Clutch Release Spring



Figure400-83 Air Checking Intermediate Clutch

**NOTICE:** Use a pipe that closely fits output shaft and does not contact gear teeth. Contact with gear teeth would result in damage to the gear as it is driven into place.

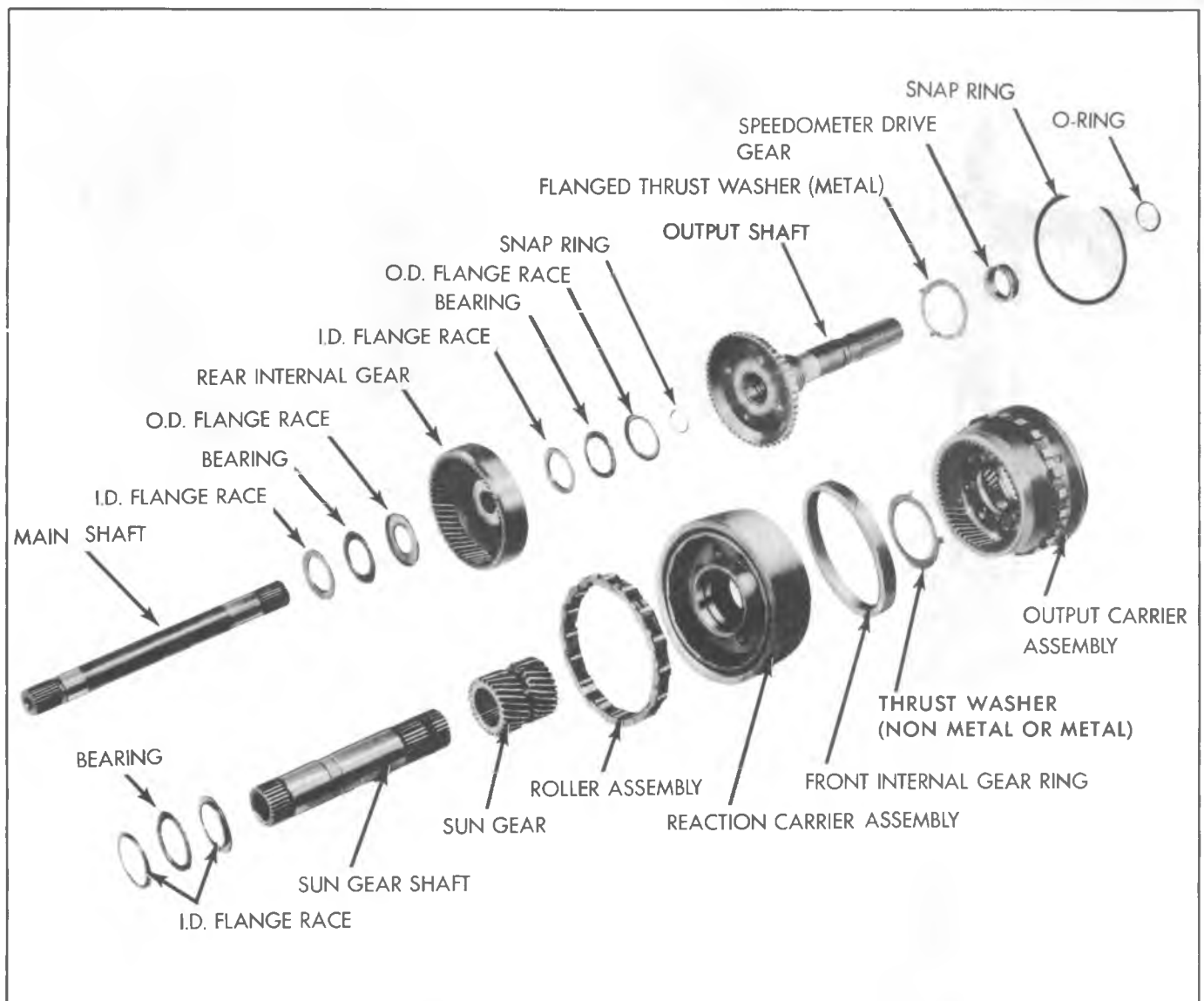

Figure 400-84 Gear Unit - Disassembled View

4. Drive gear onto shaft until distance from rear face of gear to end of output shaft is 5-21/32", **Figure 400-86**.

#### Inspection of Main Shaft

1. Inspect shaft for cracks or distortion.
2. Inspect splines for damage.
3. Inspect ground bushing journals for damage.
4. Inspect snap ring groove for damage.
5. Make sure lubrication holes are open.

#### Inspection of Rear Internal Gear

1. Inspect gear teeth and bearing surfaces for damage or wear.
2. Inspect splines for damage.
3. Inspect gear for cracks.

#### Inspection of Output Carrier Assembly

1. Inspect front internal gear for damaged teeth.
2. Inspect pinion gears for damage, rough bearings or tilt.

3. Check pinion end play. Pinion end play should be .009 inch-.024 inch, **Figure 400-87**.

4. Inspect parking gear lugs for cracks or damage.
5. Inspect output shaft locating splines for damage.
6. Inspect front internal gear ring for flaking or cracks.

#### Inspection of Reaction Carrier Assembly

1. Inspect band surface on reaction carrier for signs of burning or scoring.
2. Inspect roller clutch outer cam for scoring or wear.
3. Inspect thrust washer surfaces for signs of scoring or wear.
4. Inspect bushing for damage. If bushing is damaged, carrier must be replaced.
5. Inspect pinion gears for damage, rough bearings or excessive tilt.
6. Check pinion end play. Pinion end play should be .009 inch-.024 inch.

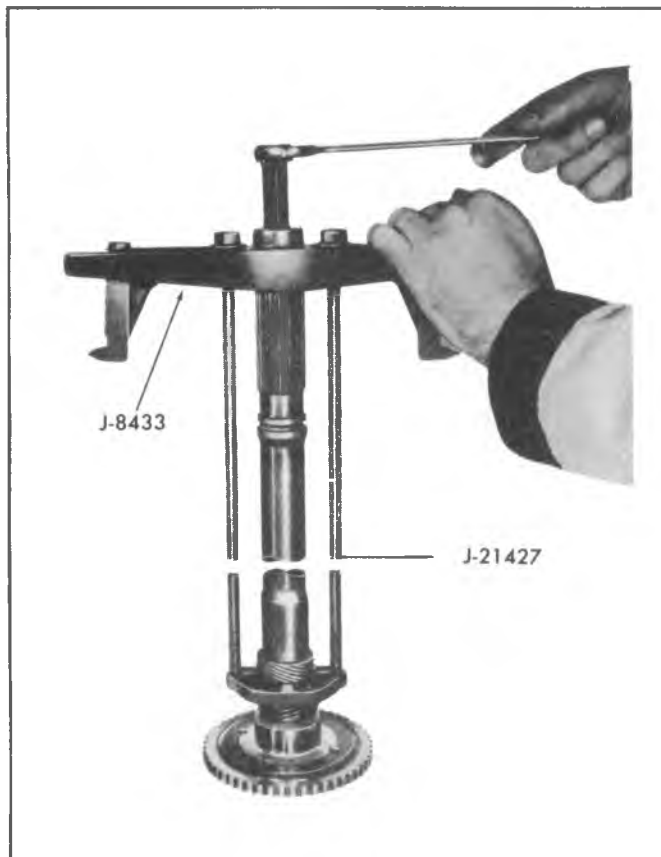

Figure 400-85 Removing Steel Speedometer Drive Gear

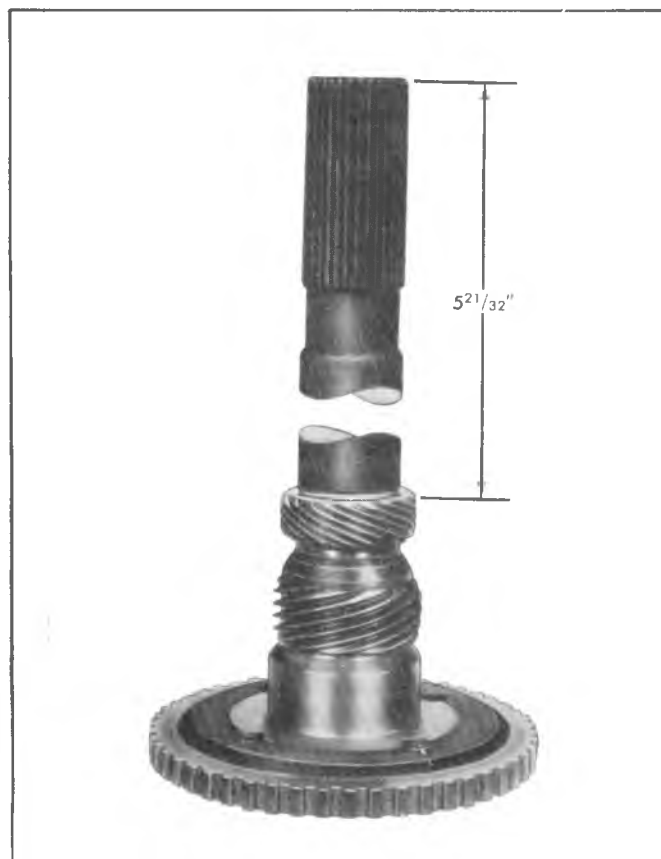

Figure 400-86 Installing Steel Speedometer Drive Gear

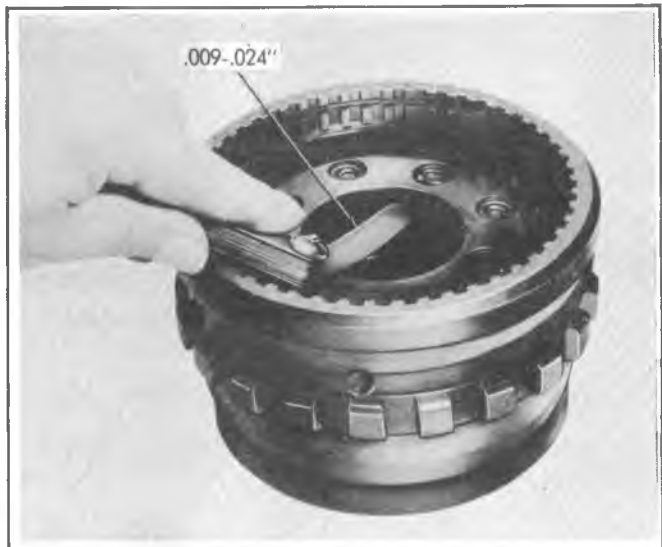

Figure 400-87 Checking Output Carrier Pinion End Play

### Pinion Gear Replacement - Reaction and Output Carrier Assemblies

1. Support carrier assembly on its FRONT face.
2. Using a 1/2 inch diameter drill, remove stake marks from the end of the pinion pin, or pins, to be replaced. This will reduce the possibility of cracking the carrier when pinion pins are pressed out.

**NOTICE:** Do not allow drill to remove any stock from the carrier as this will weaken the part and could result in a cracked carrier.

3. Using a tapered punch, drive or press pinion pins out of carrier.
4. Remove pinion gears, thrust washers, and roller needle bearings.
5. Inspect pinion pocket thrust faces for burrs and remove if present.
6. Install eighteen needle bearings into each pinion gear using petrolatum to hold bearings in place. Use a pinion pin as a guide.
7. Place a bronze and steel thrust washer on each side of pinion gear with steel washers against gear, **Figure 400-88**. Hold washers in place with petrolatum.
8. Place pinion gear assembly in position in carrier and install a pilot shaft through rear face of assembly to hold parts in place.
9. Drive a new pinion pin into place from the front, while rotating pinion gear. Be sure that headed end is flush or below face of carrier.
10. Using a punch and bench vise for an anvil, stake opposite end of pinion pin in three places with a blunt radius chisel, **Figure 400-89**.

**NOTICE:** Both ends of pinion pins must lie below face of carrier or interference may occur.

11. Repeat installation procedure for each pinion gear.

### Inspection of Roller Clutch Assembly

1. Inspect roller clutch for damaged rollers or springs.

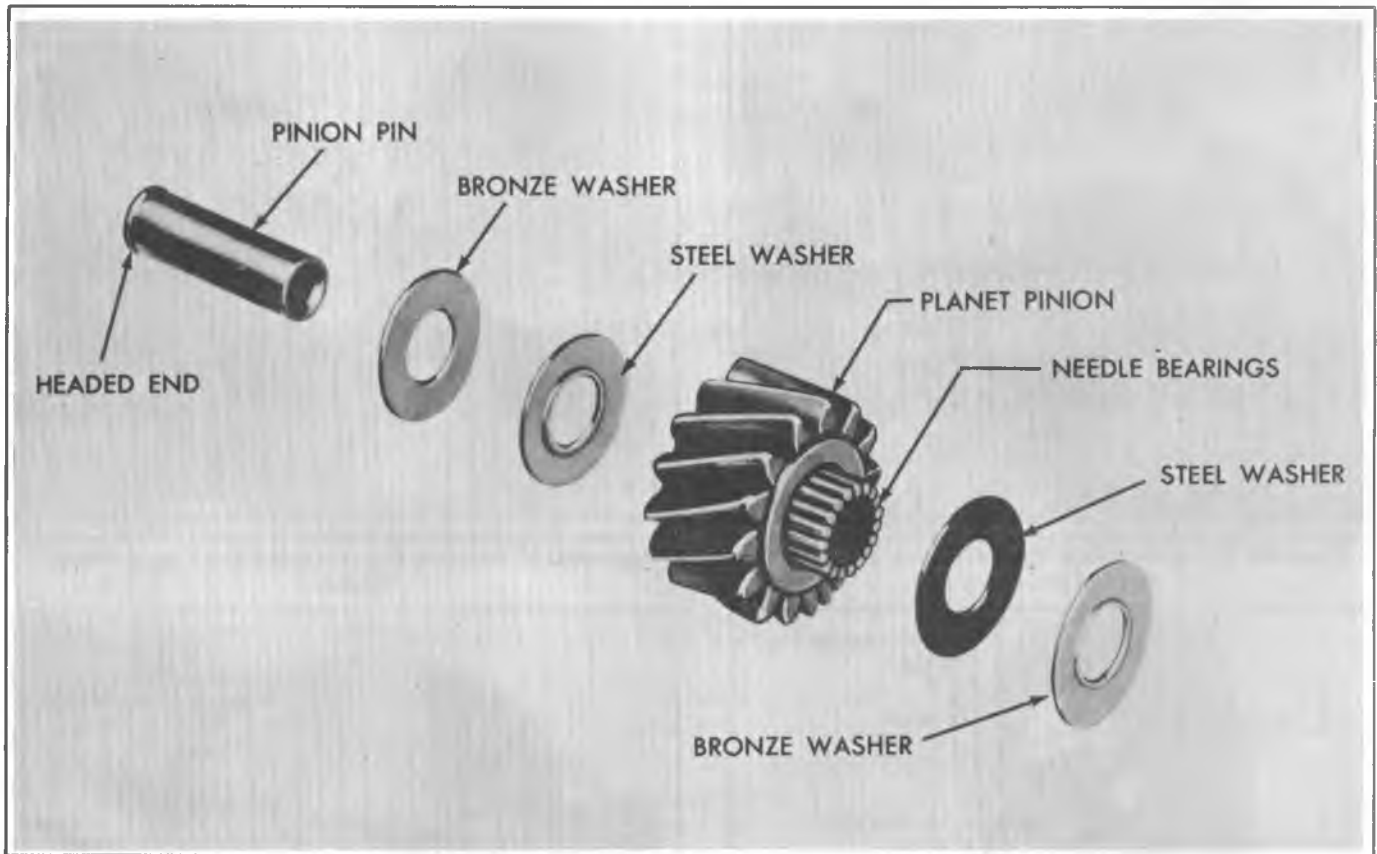

Figure400-88 Planet Pinion - Disassembled View



Figure400-89 Staking Pinion Pin

2. Inspect roller clutch cage for damage.

#### Inspection of Sun Gear

1. Inspect gear teeth for damage or wear.
2. Inspect splines for damage.
3. Be sure oil lubrication hole is open.

#### Inspection of Sun Gear Shaft

1. Inspect shaft for cracks or splits.
2. Inspect splines for damage.

3. Inspect bushings for scoring or galling.
4. Inspect ground bushing journals for damage.
5. Be sure oil lubrication hole is open.

#### ASSEMBLY OF COMPLETE GEAR UNIT

1. Install rear internal gear on end of mainshaft that has snap ring groove and install snap ring.

2. Install races and thrust bearing on inner face of rear internal gear, retaining races and bearing with petrolatum. Proceed as follows:

- a. Install large diameter race first, with flange facing up, **Figure 400-90**.
- b. Install thrust bearing in race.
- c. Install small diameter race on bearing with inner flange facing down.

3. Lubricate pinion gears in output carrier with transmission fluid and install output carrier on mainshaft so that pinion gears mesh with rear internal gear.

4. Place assembly in Rear Unit Holding Fixture, J-6116-01, with mainshaft pointing downward. Be careful not to damage shaft.

5. Install races and thrust bearing on outer face of rear internal gear, retaining races and bearing with petrolatum. Proceed as follows:

- a. Install small diameter (flanged I.D.) race first, with flange facing up, **Figure 400-91**.
- b. Install thrust bearing in race.
- c. Install large diameter (flanged O.D.) race on bearing with flange cupped over bearing.



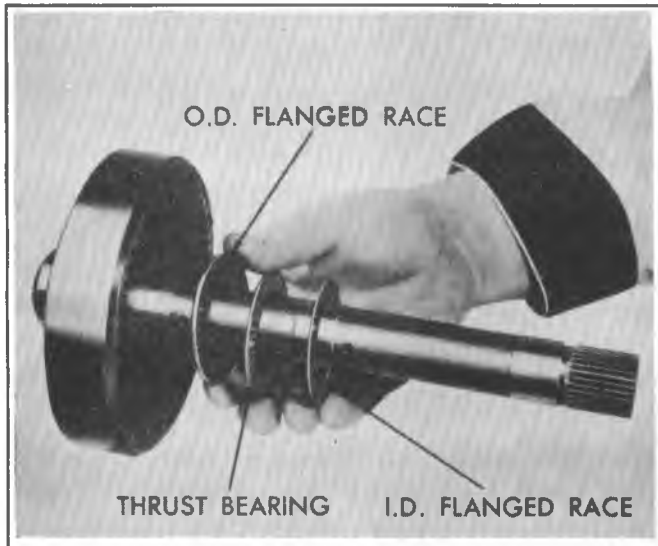

Figure 400-90 Installing Rear Internal Gear-to-Sun Thrust Bearing and Races

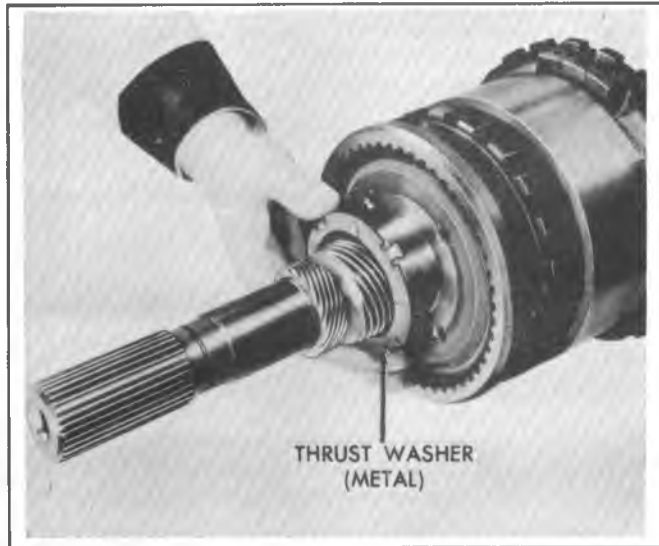

Figure 400-92 Installing Case-to-Output Shaft Metal Thrust Washer

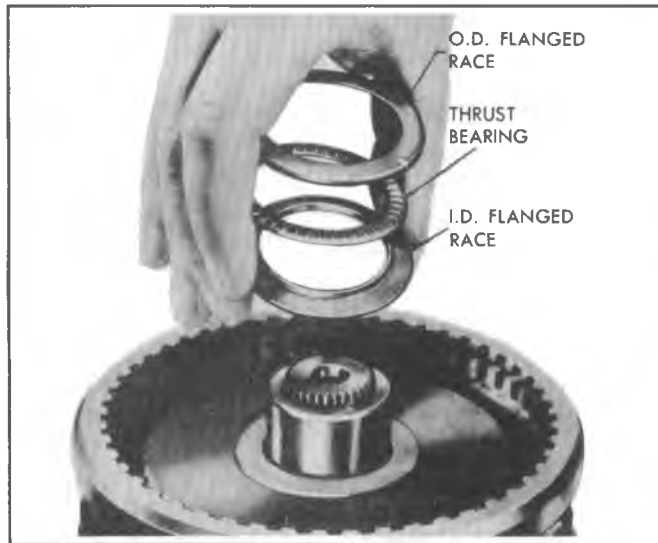

Figure 400-91 Internal Gear, Thrust Bearing and Races

6. Install output shaft into output carrier and install snap ring. Install new O-ring on output shaft.

7. Invert assembly in Holding Fixture with output shaft pointing downward.

8. Lubricate tab side of reaction-to-output carrier thrust washer with petrolatum and install thrust washer in output carrier with tabs in tab pockets, **Figure 400-92**.

9. Install sun gear with end having chamfered I.D. facing down.

10. Install sun gear shaft with longer splined end down.

11. Install gear ring over output carrier.

12. Lubricate pinion gears in reaction carrier with transmission fluid and install reaction carrier on output carrier, **Figure 400-93**, so that pinion gears mesh with front internal gear.

When a new output carrier and/or reaction carrier is being installed, and if the front internal gear ring prevents assembly of the carriers, replace the front internal gear ring with the service ring. The front internal gear ring is a selective fit at the factory but not in service.



Figure 400-93 Installing Reaction Carrier to Output Carrier

13. Install large diameter O.D. race on sun gear with flange facing up against sun gear shaft.

14. Install thrust bearing on race.

15. Lubricate small diameter race with petrolatum and install race on center support with flange facing toward lower end, **Figure 400-94**.

16. Lubricate reaction carrier to center support thrust washer with petrolatum and install washer in recess in center support, **Figure 400-47**.

17. Install rollers that may have come out of roller clutch cage, by compressing energizing spring with

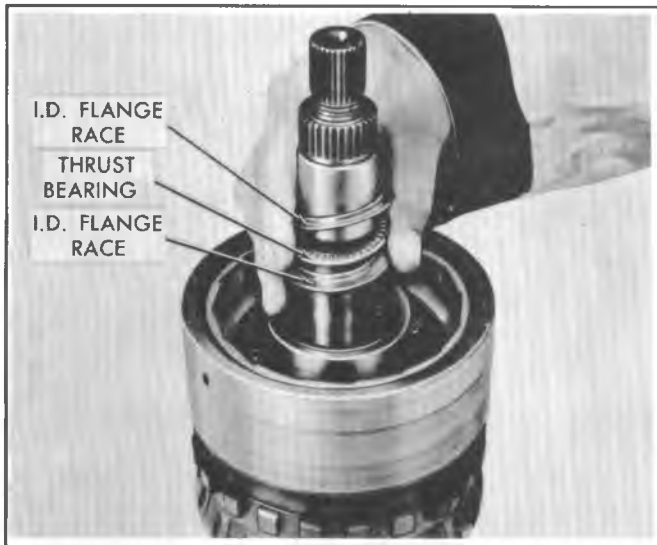

Figure 400-94 Installing Center Support Thrust Bearing Over Sun Gear Shaft

forefinger and inserting roller from outer side, **Figure 400-95**.

Make certain that energizing springs are not distorted, and that curved end leaf of springs are positioned against rollers.

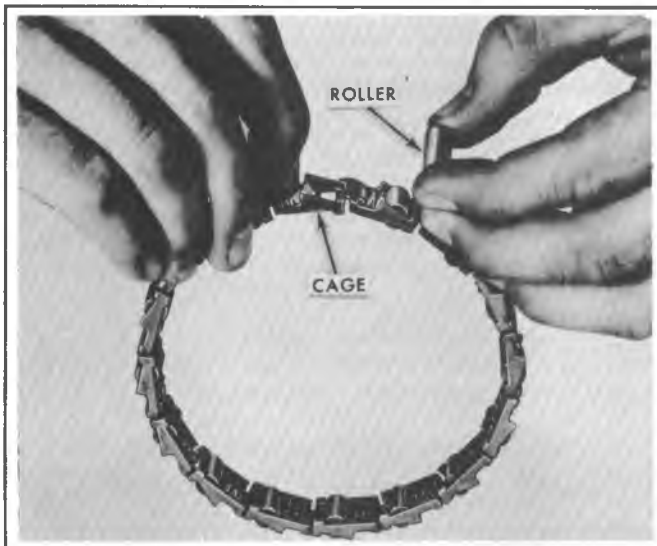

Figure 400-95 Installing Rollers in Roller Clutch Cage

18. Install roller clutch assembly in reaction carrier, **Figure 400-96**.

19. Install center support assembly into roller clutch in reaction carrier, **Figure 400-97**.

Be sure that center support to reaction carrier thrust washer is in place before installing center support assembly into roller clutch in reaction carrier.

With reaction carrier held, center support should turn counterclockwise only.

20. Install Tool J-21365 or J-21795-02, on end of main shaft so that tangs engage groove in shaft. Tighten screw on tool to secure tool on shaft and prevent movement of the roller clutch during installation of the gear unit assembly.

21. Remove gear unit from Holding Fixture and lay unit on its side. Install thrust metal washer on rear face of output shaft with bent tabs in tab pockets. Retain thrust

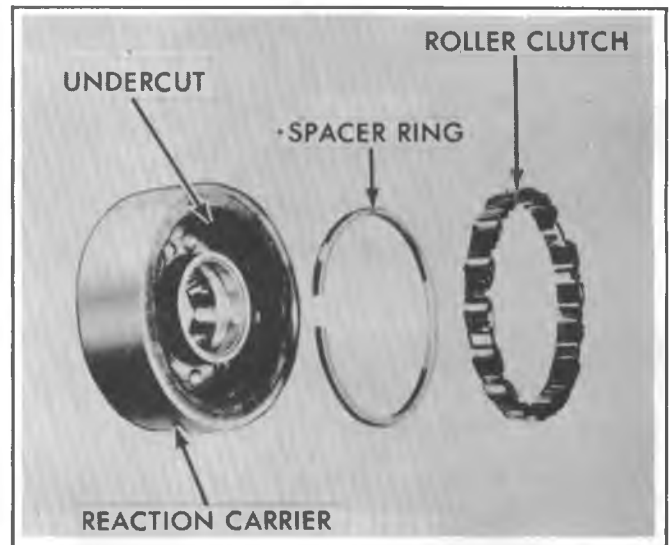

Figure 400-96 Installing Spacer Ring and Roller Clutch Assembly

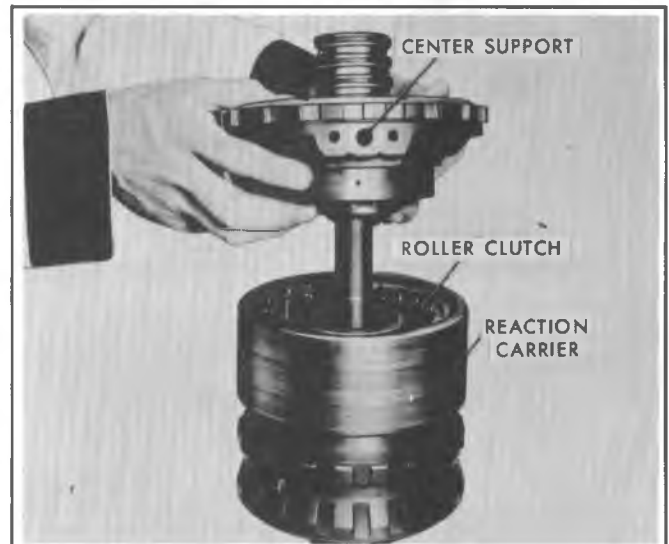

Figure 400-97 Installing Center Support to Reaction Carrier

washer with petrolatum, **Figure 400-92**. This must be a metal washer.

## MAJOR TRANSMISSION COMPONENTS INSTALLATION

### Install Parking Pawl

1. Install parking pawl, tooth toward center of transmission, and install parking pawl shaft, **Figure 400-98**.

2. Install parking pawl shaft retainer clip.

3. Install parking pawl shaft cup plug by driving into the transmission case, using a 3/8 inch diameter rod, until the parking pawl shaft bottoms on the case rib, **Figure 400-99**.

4. Install parking pawl return spring with square end hooked on pawl.

5. Install parking pawl bracket with guides over parking pawl, **Figure 400-100**. Install two attaching screws and tighten screws to 24 N·m (18 foot-pounds).



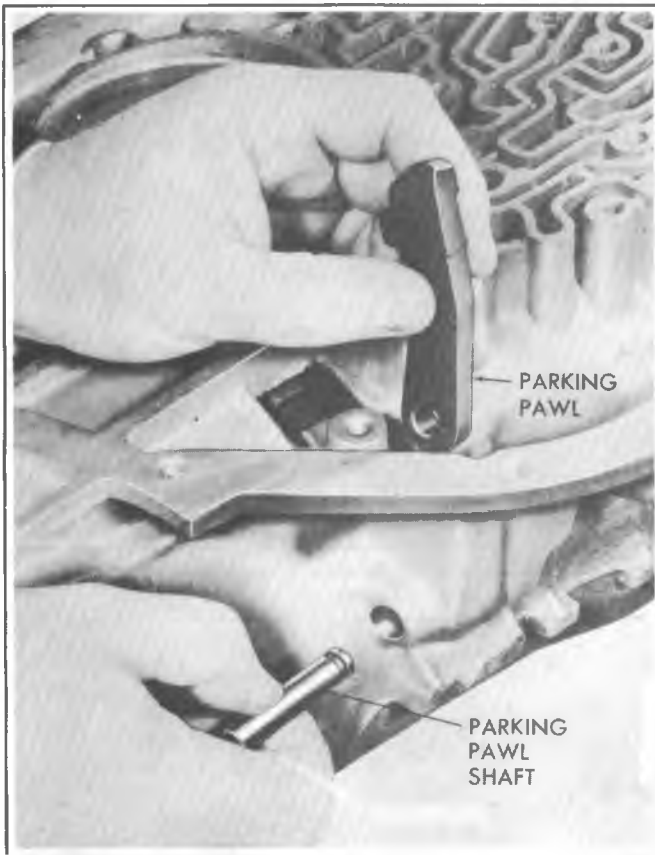

Figure 400-98 Installing Parking Pawl and Shaft



Figure 400-99 Installing Cup Plug

### Install Support to Case Spacer Rear Band and Complete Gear Unit Assembly

1. Inspect rear band for cracks or distortion and band ends for damage at anchor lugs and apply lug. Also inspect lining for cracks, flaking, burning and looseness.
2. Install rear band assembly in transmission case so that band lugs index with anchor pins, **Figure 400-102**.
3. Inspect support to case spacer for burrs or raised edges. If present, remove with a stone or fine sandpaper.

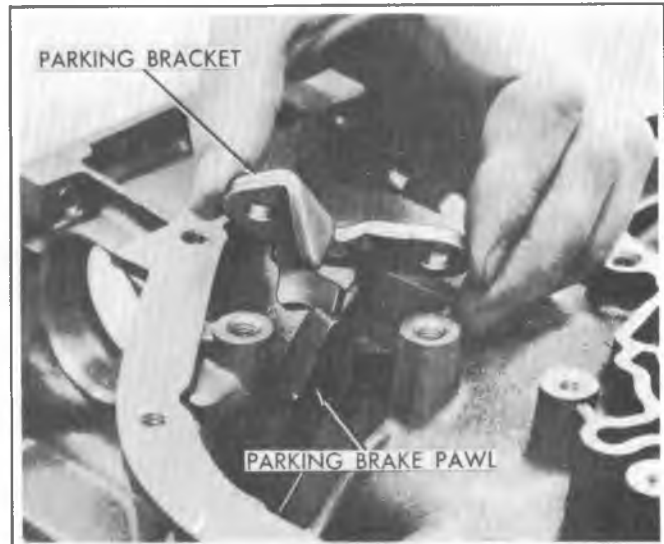

Figure 400-100 Installing Parking Pawl Bracket

4. Install the support to case spacer against the shoulder at the bottom of case splines and the gap located adjacent to the band anchor pin.

Do not confuse this spacer (.040" thick and both sides flat) with either the center support to case snap ring (one side beveled) or the backing plate to ease snap ring (.093" thick and both sides flat).

5. Install previously selected rear unit selective washer into slots provided inside rear of transmission case. Retain washer with petrolatum.

Proper washer size was determined at time of rear unit end play check.

6. Place transmission case in Holding Fixture in horizontal position. Do not over-tighten transmission Holding Fixture side pivot pin as this will cause binding when gear unit is installed.

7. Install proper diameter length of pipe to output shaft to be used as a handle and to prevent any damage to case bushing when installing unit assembly.

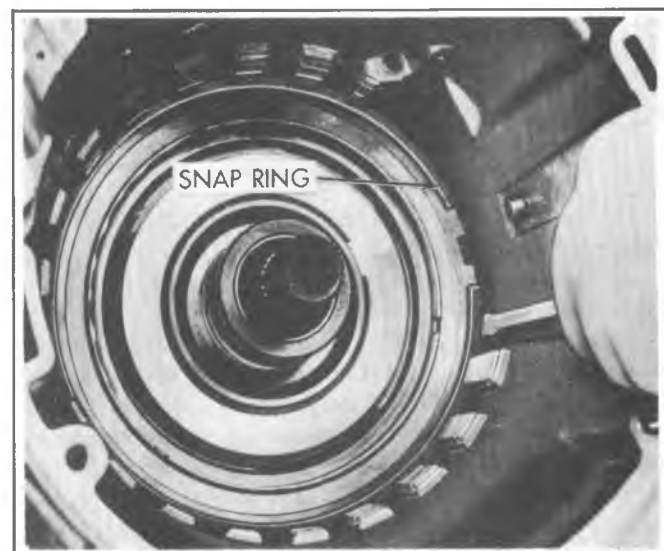

Figure 400-101 Beveled Snap Ring Location

**NOTICE:** Be careful not to drop or bump assembly in transmission case during installation. This could result in damage to output shaft case bushing as well as to assembly itself.

8. Install gear unit with center support and reaction carrier, by lining up slots and carefully guiding complete assembly horizontally into transmission case, making certain the center support bolt hole is properly aligned with hole in case.

9. Position transmission vertically with front end of case facing upward. Remove tool, J-21365 or J-21795-02.



Figure 400-102 Installing Rear Band Assembly

10. Lubricate center support to case snap ring with transmission fluid and install snap ring in transmission case with beveled side up, flat side against center support, locating gap adjacent to front band anchor pin, **Figure 400-101**. Expand snap ring until center support is against shoulder of case.

11. Install case to center support bolt.

To correctly perform this operation, it will be necessary to use tool, J-23093 or to make the tool and follow the installation procedure described below.

Make the tool from 3/8" (.375" diameter) cold roll steel or from a screwdriver with a 3/8" diameter shank. The stock should be approximately 12" long. Grind the stock to a blunt point, tapering it 7/8" from the end of the bar to a 1/8" diameter at the end, **Figure 400-103**.

Bend the bar to a 45° angle 2-1/2" from the pointed end, **Figure 400-103**.

Place the center support locating tool into the direct clutch passage in the case, with the handle of the tool pointing to the right as viewed from the front of the transmission and parallel to the bell housing mounting face.

Apply pressure downward on the tool handle, which will tend to rotate the center support counterclockwise as viewed from the front of the transmission. While holding the center support firmly counterclockwise against the case splines, torque the case-to-center support bolt to 31 N·m (23 ft.lbs.) using a 3/8" thin wall deep socket.

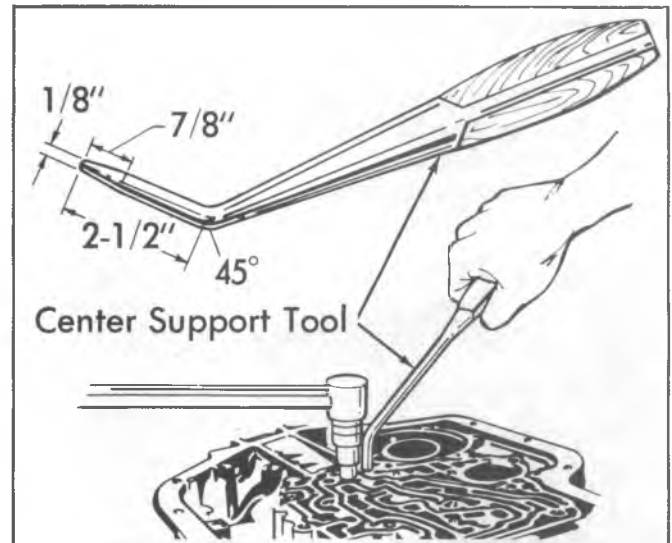

Figure 400-103 Locating Center Support

**NOTICE:** When using the locating tool, take care not to raise burrs on the case valve body mounting face.

12. Before installing intermediate clutch plates, inspect plates for signs of burning, scoring, and wear.

13. Lubricate three steel and three composition faced intermediate clutch plates with transmission fluid and install clutch plates in transmission case, **Figure 400-104**. Start with the waved steel plate and alternate composition faced and flat steel plates.

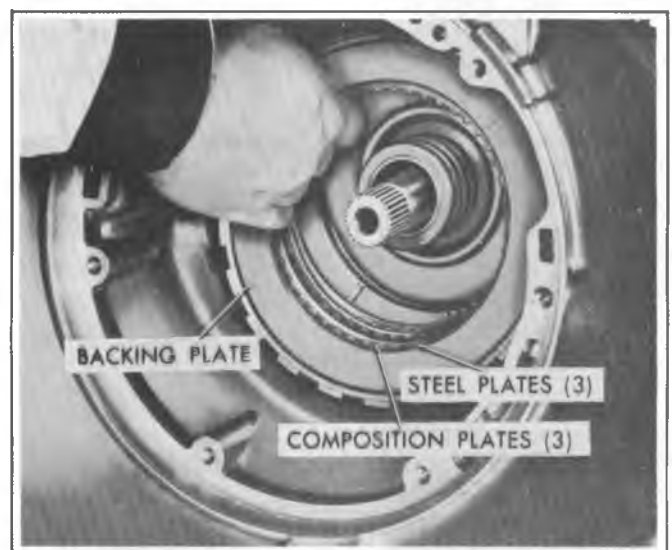

Figure 400-104 Installing Intermediate Clutch Plates

14. Install intermediate clutch backing plate with flat machined surface against clutch plates.

15. Install backing plate to case snap ring with snap ring gap on side of case opposite front band anchor pin.

Both sides of the snap ring are flat and it is approximately .093" thick.

16. Recheck rear unit end play, **Figure 400-44**.

### Install Front Band and Remaining Clutch Assemblies

1. Inspect front band for cracks or distortion and band ends for damage at anchor lug and apply lug. Also inspect lining for cracks, flaking, burning, and looseness.

2. Install front band with band anchor hole over band anchor pin, and apply lug facing servo hole, **Figure 400-105**.

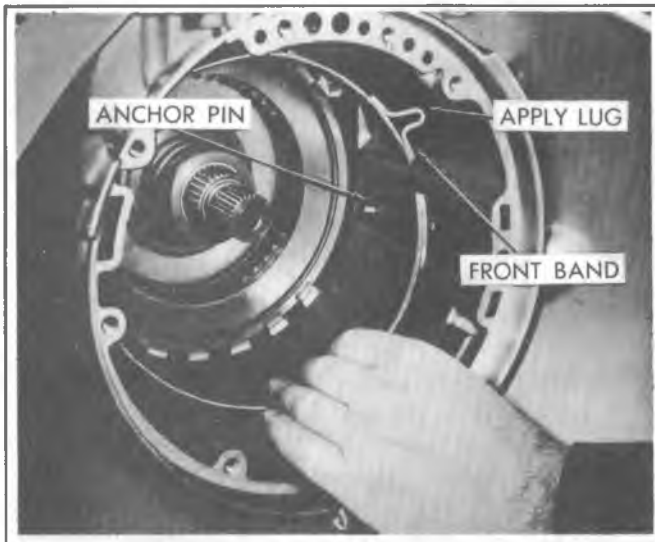

Figure 400-105 Installing Front Band

3. Install direct clutch housing and intermediate roller assembly. Make certain that clutch housing hub bottoms on sun gear shaft and splines on forward end of sun gear shaft are flush with splines in direct clutch housing. Clutch Alignment Tool J-24396 is available to position clutch plates for ease of installation.

It will be necessary to rotate clutch housing to allow roller outer race to index with intermediate clutch composition-faced plates. Removal of direct clutch composition and steel plates may be helpful and applying air pressure through the center support screw to apply the intermediate clutch plates may facilitate assembly.

4. Install forward clutch hub to direct clutch housing thrust washer on forward clutch hub. Retain with petrolatum.

5. Position transmission horizontally in Holding Fixture and install forward clutch assembly and turbine shaft, **Figure 400-106**. Make certain end of main shaft goes all the way into forward clutch hub. It will be necessary to rotate clutch housing to allow direct clutch driving hub to index with direct clutch composition plates. When forward clutch is seated, it will be approximately 32 mm (1-1/4 inches) from pump mounting face in case. **Measure this distance.**

Missing internal splines in forward clutch hub are lubrication passages and do not have to be indexed with any particular spline on main shaft.

### Install Oil Pump

1. Lubricate turbine shaft journals with transmission fluid and lubricate teflon oil rings on pump delivery sleeve with petrolatum.



Figure 400-106 Installing Forward Clutch Assembly

2. Install Slide Hammer Bolts, J-6125-1, through two opposite unthreaded holes in pump assembly to serve as guide pins when installing pump.

3. Properly align pump to case gasket on case mounting face.

4. Position pump assembly in transmission case and thread Slide Hammer assemblies into their corresponding threaded holes in transmission case.

5. Install pump assembly in transmission case. Do not remove slide hammer bolts until last two pump attaching screws are installed.

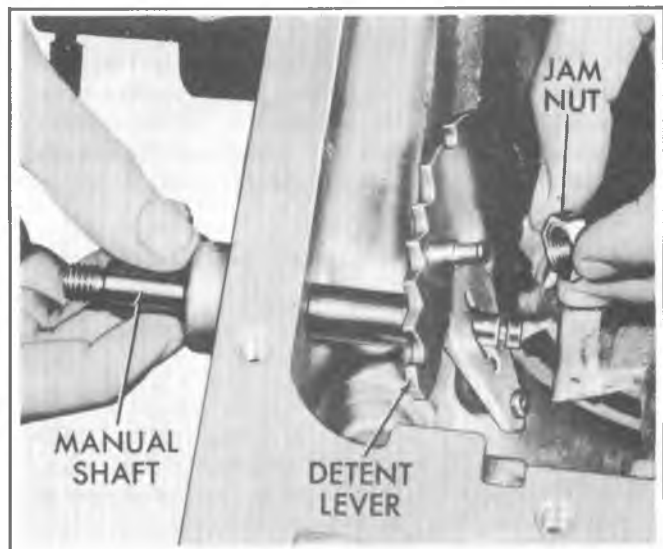

Figure 400-107 Installing Manual Shaft

6. Using six new rubber-coated washers on pump attaching screws, install all but one attaching screw at either 5 o'clock or 10 o'clock position so that front unit end play can be rechecked. Tighten screws to 24 N·m (18 foot-pounds).

If turbine shaft cannot be rotated as pump is being pulled into place, the forward or direct clutch housings have not been installed properly to index with all the clutch plates. This condition must be corrected before pump is pulled fully into place.

7. Recheck front unit end play.
8. Install remaining pump attaching screw using new rubber coated washer. Tighten screw to 24 N·m (18 foot-pounds).
9. Apply non-hardening sealer to outside of new seal and install new front seal using Pump Oil Seal Installer, J-21359.

**Install Parking Linkage, Detent Lever, and Manual Shaft**

1. If necessary install a new manual shaft lip seal into transmission case using a 3/4" diameter rod to seat the seal.
  2. Insert actuator rod into manual detent lever from side opposite pin.
  3. Install actuator rod plunger under parking bracket and over parking pawl.
  4. Install manual shaft into case and through detent lever, **Figure 400-107**.
  5. Install locknut on manual shaft. Tighten nut to 24 N·m (18 foot-pounds).
  6. Install external manual yoke on manual shaft if removed. Tighten nut to 24 N·m (18 foot-pounds).
  7. Install retaining pin in case, indexing it with groove in manual shaft, **Figure 400-108**.
- If procedure is being performed with transmission in car, install and straighten bent pin.

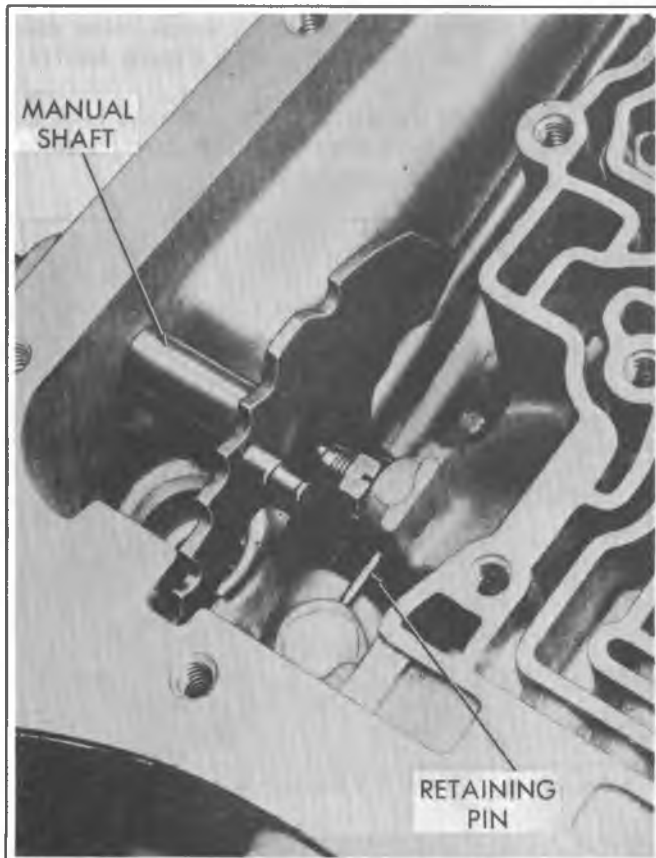

Figure400-108 Retaining Pin

**install Extension Housing**

1. Install new gasket on extension housing, retaining with petrolatum.

2. Check O-ring on output shaft for any nicks or flattening and replace O-ring if either condition exists.
3. Secure extension housing to case with six attaching screws. Tighten screws to 31 N·m (23 foot-pounds).
4. If necessary, install a new extension housing oil seal using Oil Seal Installer, J-21359. Apply non-hardening sealer to outside of seal before installation.

**Install Check Balls, Control Valve, Spacer Plate Gaskets, Detent Solenoid, Front Servo Assembly and Electrical Connector**

1. Install two control valve assembly attaching bolts with heads cut off as guide pins as shown in **Figure 400-112**.
2. Install five check balls into ball seat pockets in transmission case, **Figure 400-109**.

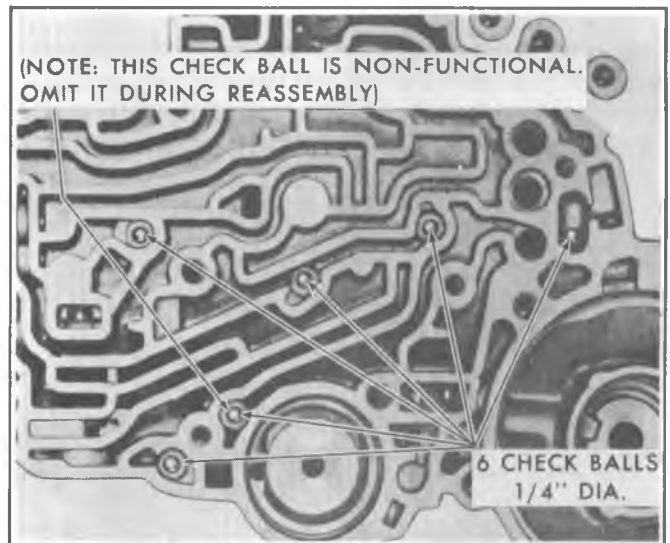

Figure400-109 Location of Check Balls

If transmission is in car, install check balls into ball seat pockets on spacer plate, **Figure 400-110**.

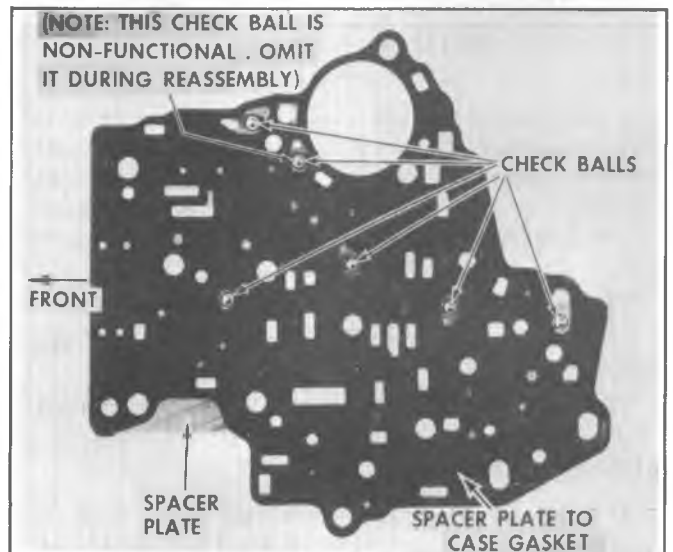

Figure400-110 Spacer Plate Gasket with Check Balls

3. Install control valve spacer plate-to-case gasket (gasket with extension for detent solenoid and a "C" near front servo location).

4. Install control valve spacer plate.

5. Install detent solenoid gasket.

6. Install detent solenoid assembly with connector facing outer edge of case. **Do not tighten bolts at this time.**

7. Install front servo spring and spring retainer into transmission case.

8. Install retainer ring in front servo pin groove and install pin into case so that tapered end contacts band. Make certain retainer ring is installed in servo pin groove.

9. Install seal ring on servo piston, if removed, and install on servo pin with flat side of piston positioned toward bottom pan.

The ring allows the front servo piston to slide very freely in the case. The free fit of the ring in the bore is a normal characteristic and does not indicate leakage during operation. The teflon ring should only be replaced if it shows damage or if evidence of leakage during operation exists.

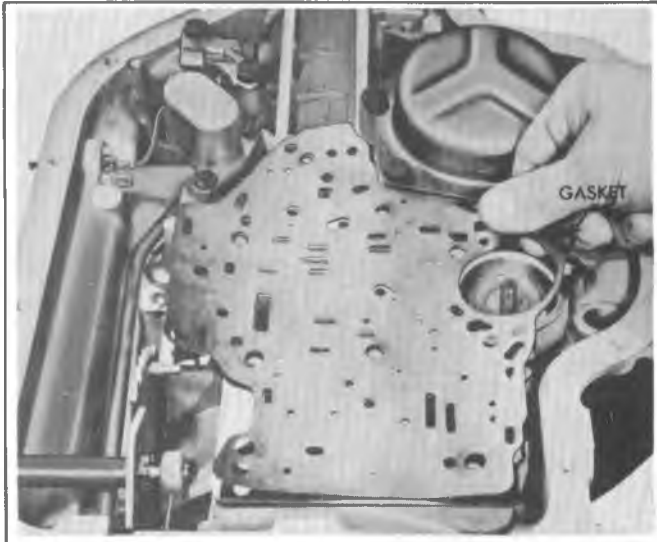

Figure 400-111 Installing Spacer Gasket

If transmission is in car, assemble front servo group as shown in **Figure 400-58** and install this group of parts into front servo bore in case and hold. Slip a length of straight, clean feeler gage or shim stock (about .020") between spacer plate and front servo piston to temporarily retain front servo group.

10. Install new O-ring on solenoid connector.

11. Install connector with lock tabs pointing into case. Position locator tab in notch on side of case.

12. Connect detent solenoid wire to connector terminal.

### Install Rear Servo Assembly

1. Lubricate inner and outer rear servo bores in transmission case with transmission fluid and install rear accumulator spring in servo inner bore.

Before installing rear servo assembly, make certain that rear band apply lug is aligned with servo pin bore in transmission case. Otherwise servo pin will not apply band.

2. Position rear servo assembly in transmission.

3. Press down on rear servo assembly, making certain it is properly seated in case bore, and install rear servo cover and new gasket. Install six attaching screws, tightening screws to 24 N·m (18 foot-pounds).

### Install Control Valve Assembly, Governor Pipes, Governor Screen Assembly

1. Install control valve assembly-to-spacer gasket (gasket with "VB" near front servo location).

2. Install governor pipes on control valve assembly. Governor pipes are interchangeable.

3. Install governor screen assembly, open end first; into governor feed pipe hole in case (hole nearest the center of transmission). **Figure 400-32.**

4. Install control valve assembly and governor pipes on transmission, while carefully aligning the governor feed pipe over the governor screen, **Figure 400-112.** Make certain gaskets and spacer do not become mispositioned. See **Figure 400-111.**

Check manual valve to make sure it is indexed properly with pin on detent lever and governor pipes to make certain they are properly seated in case holes.

5. Start control valve assembly attaching screws.

If transmission is in vehicle, remove feeler stock before tightening any control valve screws.

6. Remove guide pins and install detent roller and spring assembly and remaining screws, **Figure 400-113.** Torque bolts to 10 N·m (8 ft.lbs).

7. Tighten detent solenoid attaching screws to 14 N·m (10 foot-pounds). Solenoid screws should be zinc plated to provide a good electrical connection.

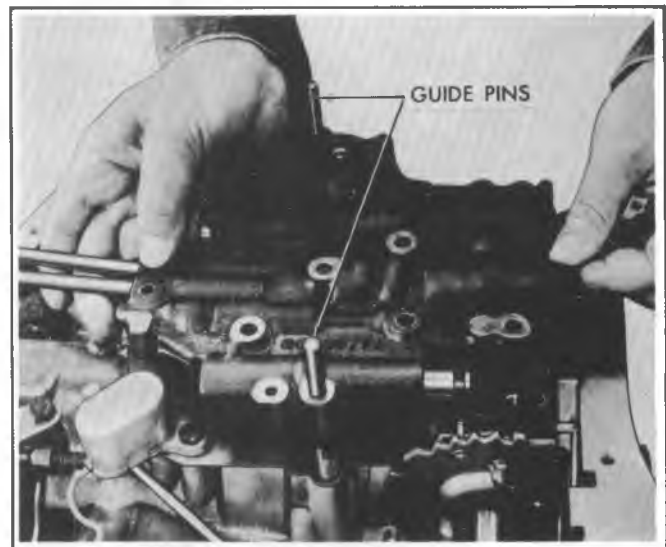

Figure 400-112 Installing Control Valve Assembly.

### Install Modulator Valve and Vacuum Modulator

1. Install modulator valve into case with stem end out.

2. Install new O-ring on vacuum modulator.

3. Install vacuum modulator into case with vacuum hose pipe facing front of car and angled 5° toward top of case.



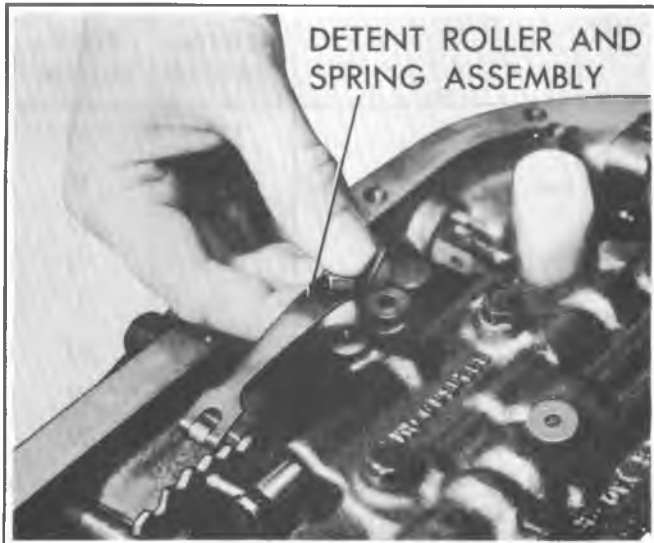

Figure 400-113 Installing Detent Roller and Spring

4. Install modulator retainer with curved side of tangs, inboard and install attaching screw. Tighten screw to 24 N·m (18 foot-pounds).

#### Install Governor Assembly

1. Install governor assembly into case.
2. Using a new gasket, attach governor cover to case with four attaching screws. Torque screws to 24 N·m (18 foot-pounds).
- If transmission is in car proceed as follows.
3. Install two bolts securing transmission extension housing to crossmember.

#### Install Speedometer Driven Gear Assembly

Speedometer driven gears are provided in three different tooth sizes. Driven gear and matching sleeve must be installed to correspond with axle ratio.

1. Lubricate driven gear selected from chart with a small amount of DEXRON<sup>®</sup> - II transmission fluid and position driven gear.

2. Install speedometer driven gear retainer with tangs in sleeve positioning bosses, and install attaching screw. Tightening screw to 24 N·m (18 foot-pounds).

**NOTICE:** Never turn sleeve in transmission case as shaft centerline is eccentric with outside diameter and gear damage will result.

#### Install Intake Pipe and Filter Assembly and Bottom Pan

1. Install new intake pipe O-ring onto pipe and install pipe assembly into new filter assembly.
2. Install filter and intake pipe assembly into case bore, **Figure 400-30**.
3. Install filter retainer bolt, and tighten to 14 N·m (10 foot-pounds). **Figure 400-29**.
4. Install new gasket on bottom pan and install bottom pan.
5. Install 13 bottom pan attaching screws. Tighten screws to 16 N·m (12 foot-pounds).

Intake pipe is marked "filter" and "case" assemble "filter" end into filter.

#### Install Converter

1. Install converter on turbine shaft making certain that converter drive hub slots are fully engaged with the pump drive gear tangs.
2. Install Converter Holding Clamp, J-21366, on front of transmission case.

## TRANSMISSION CASE REPAIRS

### Repairing Tapped Holes

Thread repair inserts are available from various sources and are recommended for restoring damaged threads. The instructions provided with your specific repair kit should be followed.

**58 TRANSMISSION - 400**

| APPLICATION  | NEWTON-METRES | FOOT-POUNDS |
|--|---------------|-------------|
| FILTER TO VALVE BODY SCREW . . . . .   | 13.5          | 10          |
| SOLENOID TO CASE SCREW . . . . .   | 13.5          | 10          |
| CONTROL VALVE ASSEMBLY TO CASE SCREW . . . . .   | 13.5          | 10          |
| LINE PRESSURE PLUG . . . . .   | 13.5          | 10          |
| FLYWHEEL HOUSING COVER TO TRANSMISSION SCREW. . . . .                                      | 8             | 5           |
| PUMP BODY TO COVER SCREW . . . . .   | 27            | 20          |
| PUMP ASSEMBLY TO CASE SCREW. . . . .   | 27            | 20          |
| REAR SERVO COVER TO CASE SCREW . . . . .   | 27            | 20          |
| GOVERNOR COVER TO CASE . . . . .   | 27            | 20          |
| PARKING PAWL BRACKET TO CASE SCREW. . . . .  | 27            | 20          |
| VACUUM MODULATOR RETAINER TO CASE SCREW . . . . .  | 27            | 20          |
| SPEEDOMETER DRIVEN GEAR RETAINER TO CASE SCREW . . . . .                                   | 8             | 6           |
| OIL PAN TO CASE SCREW . . . . .  | 17.5          | 13          |
| EXTENSION HOUSING TO CASE SCREW . . . . .  | 47            | 35          |
| MANUAL SHAFT TO DETENT LEVER NUT . . . . .   | 27            | 20          |
| MANUAL YOKE TO MANUAL SHAFT NUT . . . . .  | 24            | 18          |
| CASE TO CENTER SUPPORT SCREW. . . . .  | 34            | 25          |
| FLYWHEEL TO CONVERTER SCREW . . . . .  | 47            | 35          |
| TRANSMISSION CASE TO ENGINE SCREW . . . . .  | 47            | 35          |
| OIL COOLER PIPE CONNECTOR NUT AT CASE AND RADIATOR . . . . .                               | 27            | 20          |
| COOLER PIPE CONNECTOR AT CASE. . . . .   | 27            | 20          |
| ENGINE REAR MOUNT TO TRANSMISSION BOLT. . . . .  | 47            | 35          |
| ENGINE REAR SUPPORT BRACKET TO FRAME NUT. . . . .  | 47            | 35          |
| <b>NOTICE: REFER TO BACK OF MANUAL FOR BOLT AND NUT MARKING AND STEEL CLASSIFICATIONS.</b> |               |             |

Figure 400-114 Torque Specifications

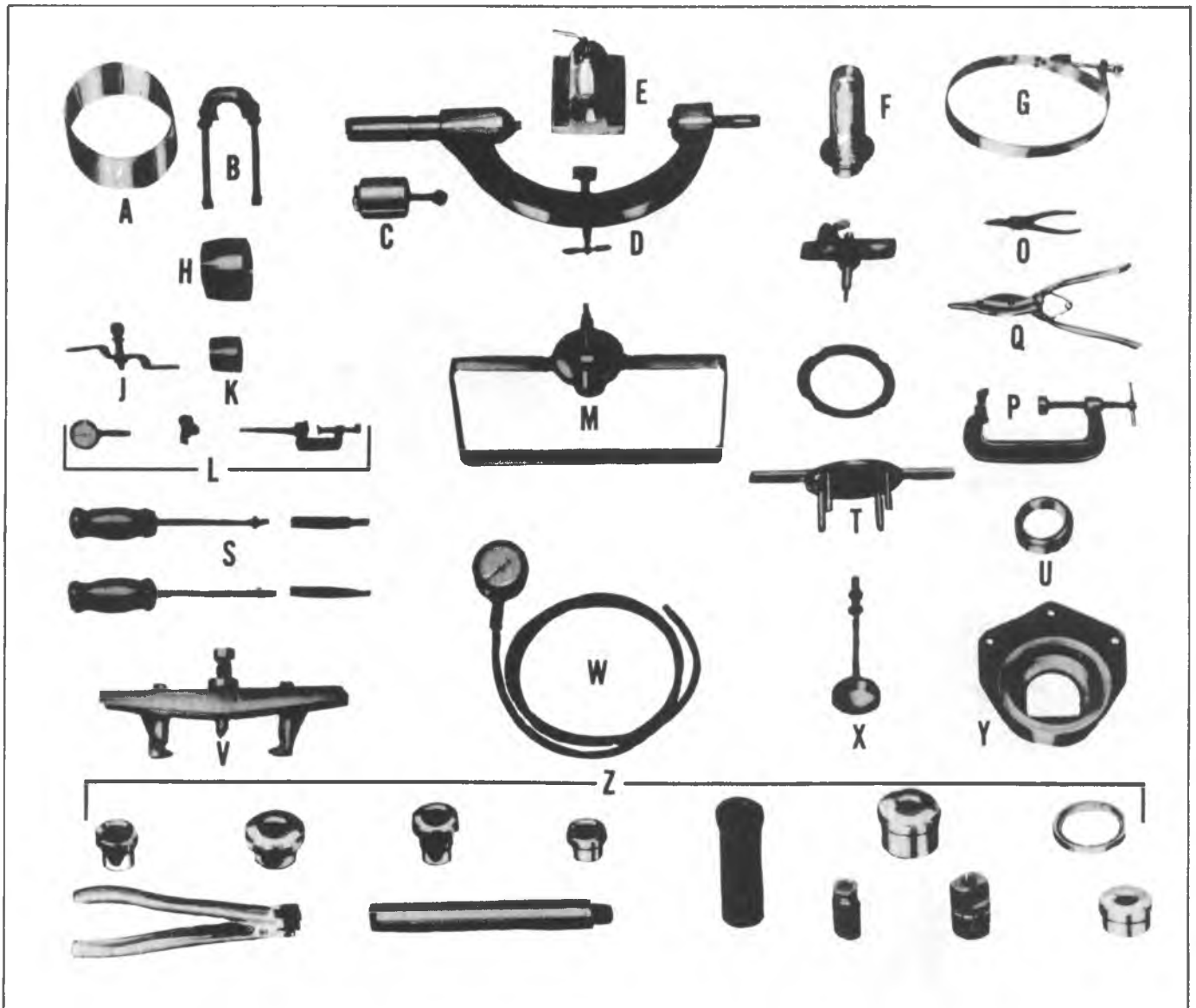

| KEY | TOOL NO.  | NAME  | KEY | TOOL NO.   | NAME  |
|-----|-----------|---|-----|------------|---|
| A   | J-21409   | Forward and Direct Clutch<br>Piston Installer     | M   | J-21369    | Converter Leak Test Fixture                         |
| B   | J-21427   | Speedometer Drive Gear Remover                    | N   | J-21370    | Band Apply Pin Selector<br>Gage (use J-21370-5 Pin) |
| C   | J-21795   | Gear Assembly Remover and<br>Installer Adapter    | O   | J-5403     | Snap Ring Pliers (#21)                              |
| D   | J-8763-02 | Transmission Holding Fixture                      | P   | J-21885    | Control Valve Accumulator<br>Piston Installer       |
| E   | J-3289-20 | Holding Fixture Base                              | Q   | J-8059     | Snap Ring Pliers                                    |
| F   | J-21359   | Pump Oil and Extension<br>Housing Seal Installer  | R   | J-21664    | Clutch Spring Compressor<br>Adapter                 |
| G   | J-21368   | Pump Body and Cover<br>Alignment Band             | S   | J-6125     | Slide Hammer Assemblies                             |
| H   | J-21363   | Intermediate Clutch Inner<br>Seal Protector       | T   | J-4670     | Clutch Spring Compressor                            |
| J   | J-21366   | Converter Holding Clamp                           | U   | J-21364    | Rear Unit Holding Fixture<br>Adapter                |
| K   | J-21362   | Forward and Direct Clutch<br>Inner Seal Projector | V   | J-8433     | Pulley Puller                                       |
| L   | J-8001    | Dial Indicator Set                                | W   | J-5907     | 0-300 PSI Pressure Case                             |
|     |           |   | X   | J-6129     | Rear Clutch Spring<br>Compressor                    |
|     |           |   | Y   | J-6116     | Rear Unit Holding Fixture                           |
|     |           |   | Z   | J-21465-01 | Bushing Service Set                                 |

Figure400-115 Special Tools



# BUSHING SERVICE 400 SERIES TRANSMISSION

When inspecting bushings, fit the mating part into the bushing and observe the amount of looseness. Bushing clearance is excessive if more than .008" exists when checked with a wire feeler gauge.

Bushings are available and can be replaced in the following units. Service bushings do not require reaming.

1. Pump Body
2. Sun Gear Shaft
3. Center Support
4. Output Shaft or Output Flange
5. Case
6. Extension Housing
7. Stator Shaft
  - a. Front Bushing
  - b. Rear Bushing

## PUMP BODY BUSHING

1. With pump disassembled and front seal removed, support pump body on wood blocks. Drive bushing out as shown using J-8092 Drive Handle and J-21465-17 Bushing Remover and Installer. **Figure 400-116**. Use a lead or brass hammer to drive out bushing.

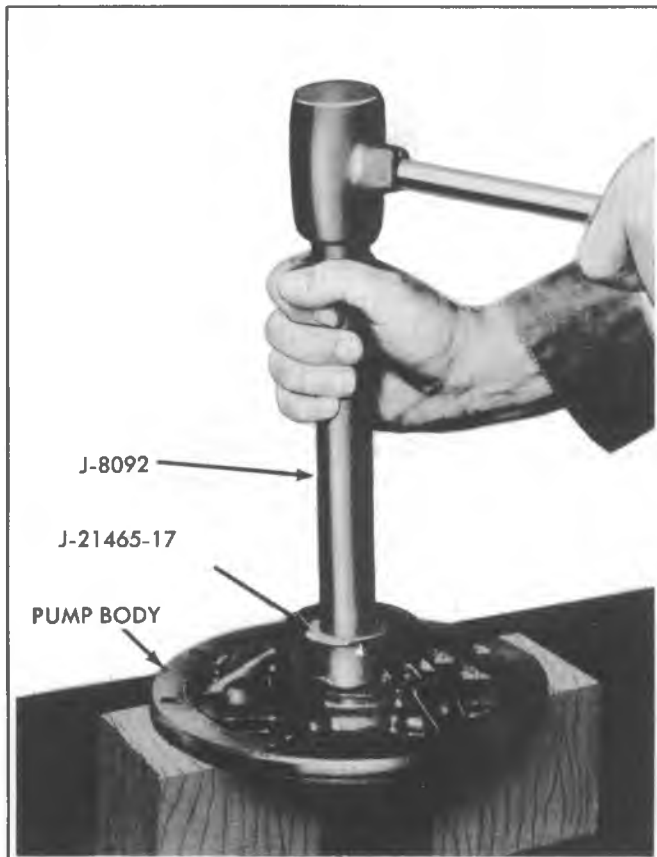

Figure 400-116 400 Pump Bushing Removal

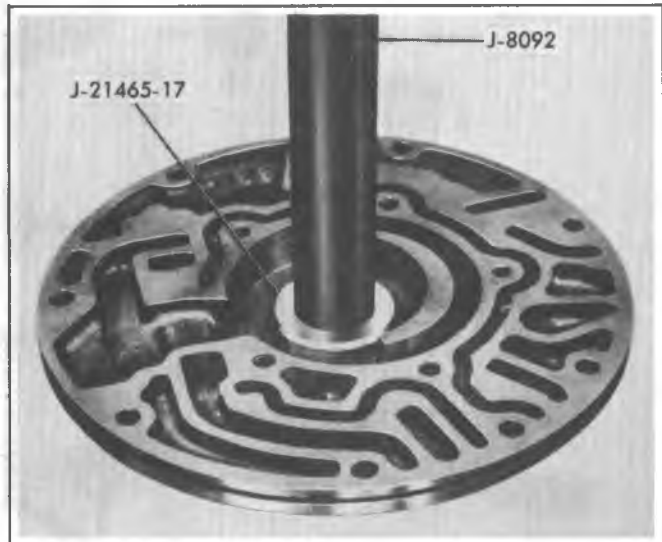

Figure 400-117 Pump Bushing Installation

2. Clean pump bushing bore, install new bushing on shoulder of Tool J-21465-17 with J-8092; and drive bushing squarely into the bore until it is flush to .010" below gear pocket face. **Figure 400-117**. Remove tool and inspect bearing.

## OUTPUT SHAFT OR OUTPUT FLANGE BUSHING

1. With output shaft or output flange properly supported using Tool J-21465-16, with Slide Hammer J-2619 and Adapter Tool J-2619-4, remove bushing, **Figure 400-118**.

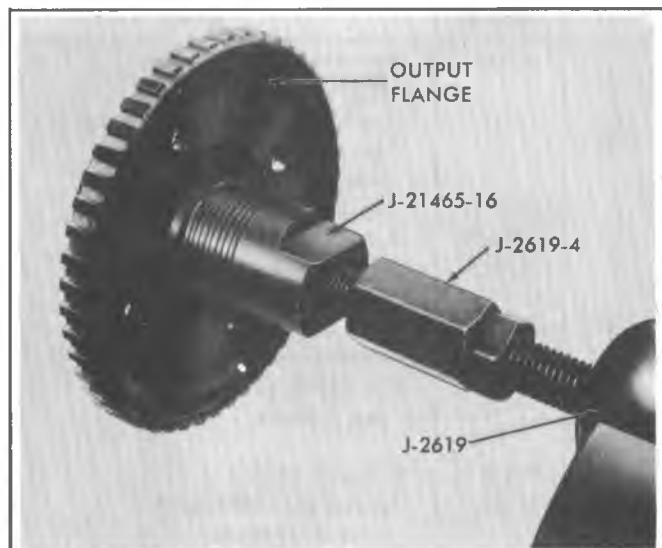

Figure 400-118 Output Flange Bushing Removal

2. Using Tool J-21465-1, with Drive Handle J-8092, press or drive replacement bushing into place until tool bottoms, **Figure 400-119**.

Output flange bushing must be installed with oil hole in bushing aligned with oil hole in hub of output flange and notch in bushing outward.

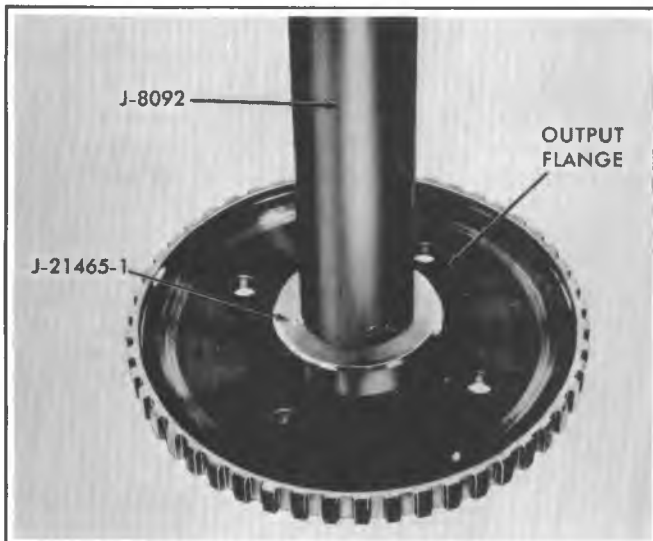

Figure 400-119 Output Flange Bushing Installation

## SUN GEAR SHAFT BUSHING - FRONT AND REAR

1. With sun gear shaft properly supported, using Tool J-21465-15, with Slide Hammer Tool J-2619 and Adapter J-2619-4, remove bushing, **Figure 400-120**

2. Using Tool J-21465-5 with Drive Handle J-8092, press or drive replacement bushing into place until tool bottoms, **Figure 400-121**.

## CENTER SUPPORT BUSHING

1. Position center support, oil delivery sleeve down, on wooden blocks that are long enough to clear bushing during removal. Assemble remover Tool J-21465-6 to Drive Handle J-8092 and drive bushing out as shown in, **Figure 400-122**, using a lead or brass hammer.

2. Invert center support and using the same tools drive new bushing squarely into the bore until bushing is flush to .010" below end of oil delivery sleeve as shown in, **Figure 400-123**. Remove tools and inspect bushing and oil hole alignment.

**NOTICE:** Slot in bushing must be aligned with the drilled hole in the oil delivery sleeve closest to the piston.

## TRANSMISSION CASE BUSHING

1. Position transmission case (converter end down). Assemble Remover Tool J-21465-8 on Drive Handle J-8092 and drive bushing out using a lead or brass hammer, as shown in, **Figure 400-124**.

2. Invert transmission case in holder. Assemble Drive Handle J-8092 and Adapter J-21465-13 on Installer J-21465-8. Assemble Adapter Ring J-21465-9 on installer and

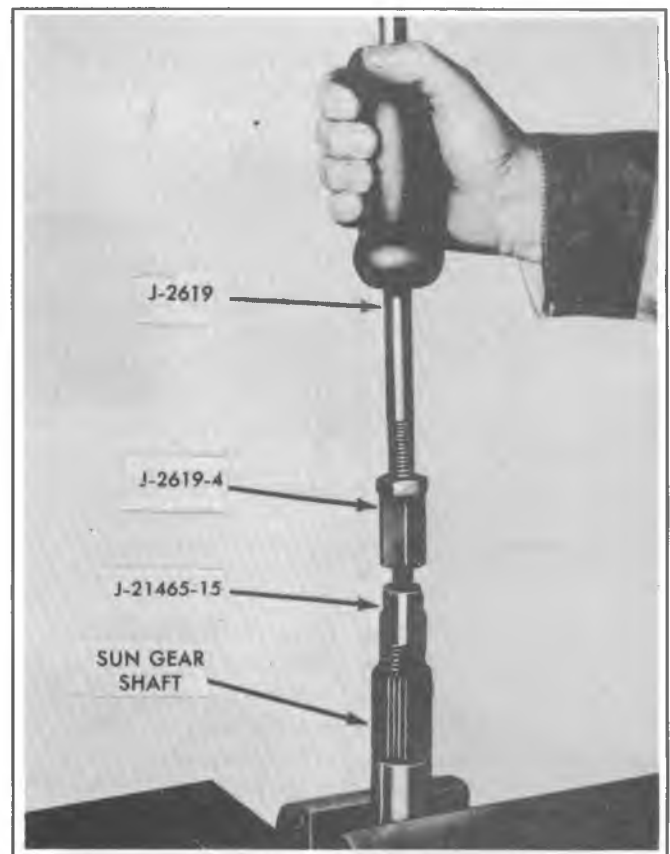

Figure 400-120 Sun Gear Shaft Bushing Removal

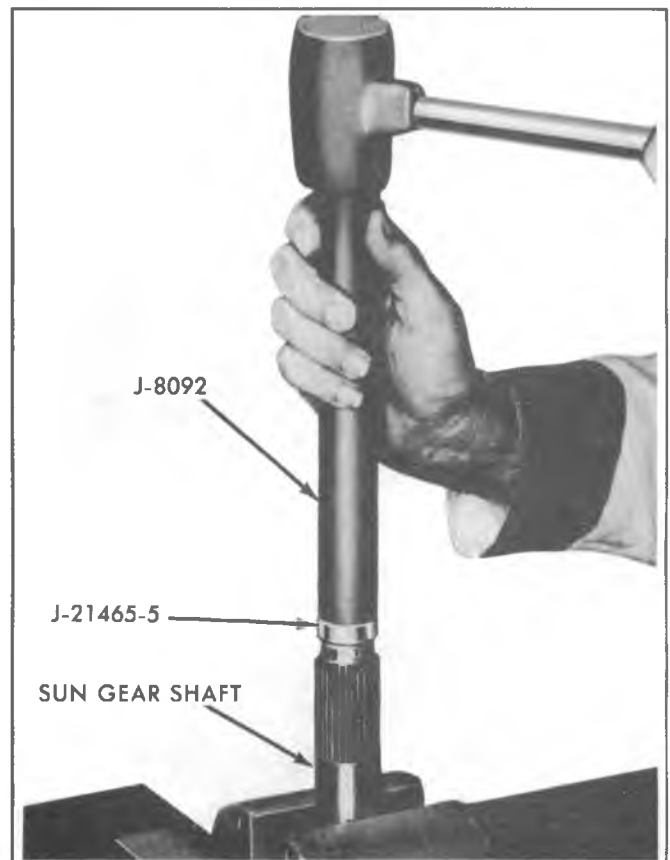

Figure 400-121 Sun Gear Shaft Bushing Installation

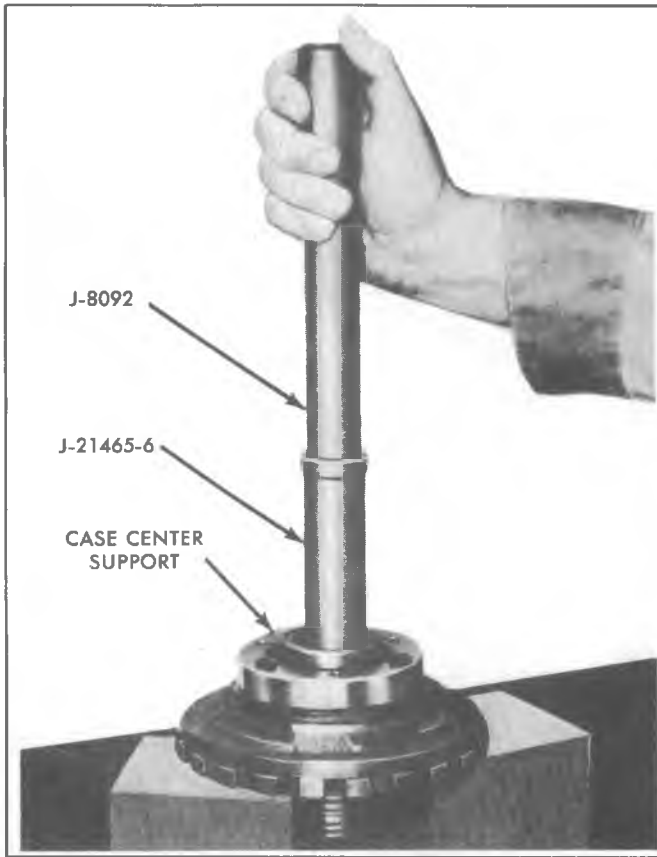

Figure 400-122 Center Support Bushing Removal.

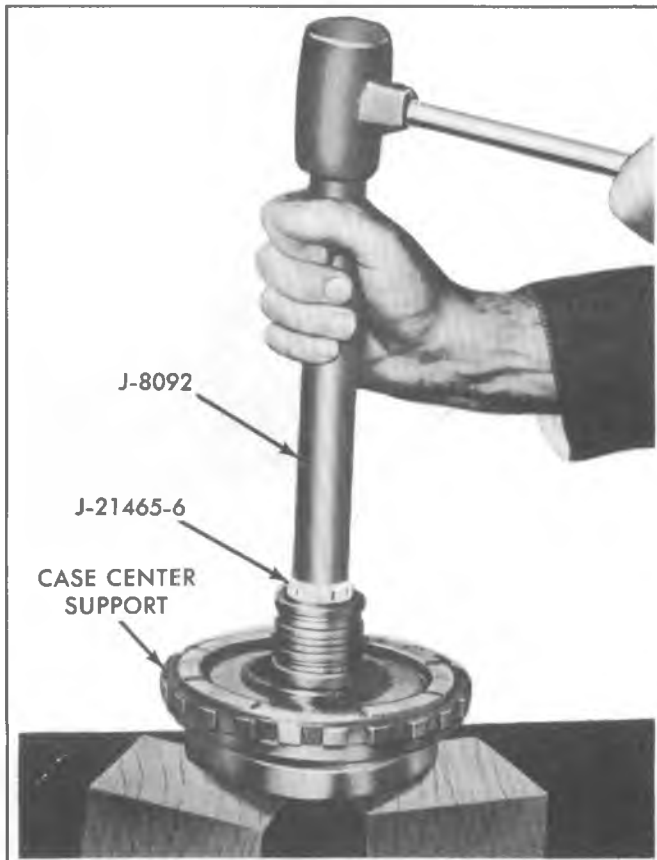

Figure 400-123 Center Support Bushing Installation

install new bushing on shoulder of installer with lube passage facing adapter ring, see, **Figure 400-125**. Drive bushing squarely into bore with lead or brass hammer until adapter ring bottoms, as shown. This will leave the bushing .040 to .055" above the selective thrust washer surface.

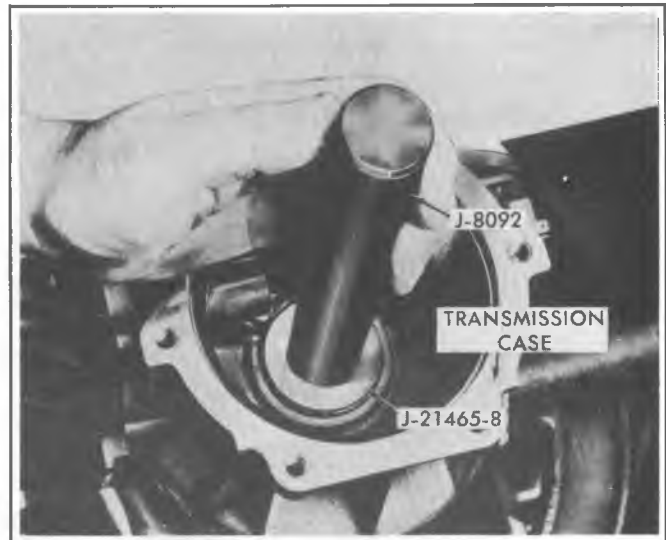

Figure 400-124 Transmission Case Bushing Removal

3. Remove tools and stake bushing with Tool J-21465-10 as shown in **Figure 400-126**. Stake marks must be in the bushing groove. Remove staking tool and inspect bushing.

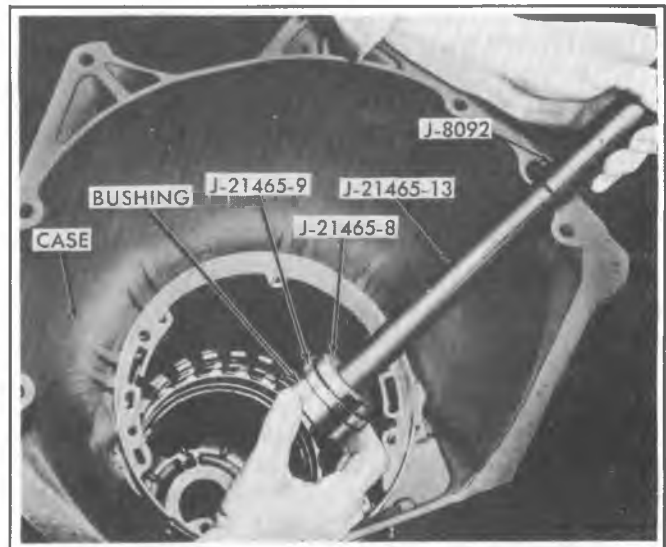

Figure 400-125 Transmission Case Bushing Installation

## EXTENSION HOUSING BUSHING

1. With rear seal removed, position extension housing on bench, seal end up. Assemble Remover J-21465-17 on Drive Handle J-8092 and drive out bushing with lead or brass hammer, as shown in, **Figure 400-127**.

2. Assemble Drive Handle J-8092 and new bushing on Tool J-21465-17 and drive bushing squarely into bore until flush to .010" below oil seal counter bore surface using a lead or brass hammer, as shown in, **Figure 400-128**.

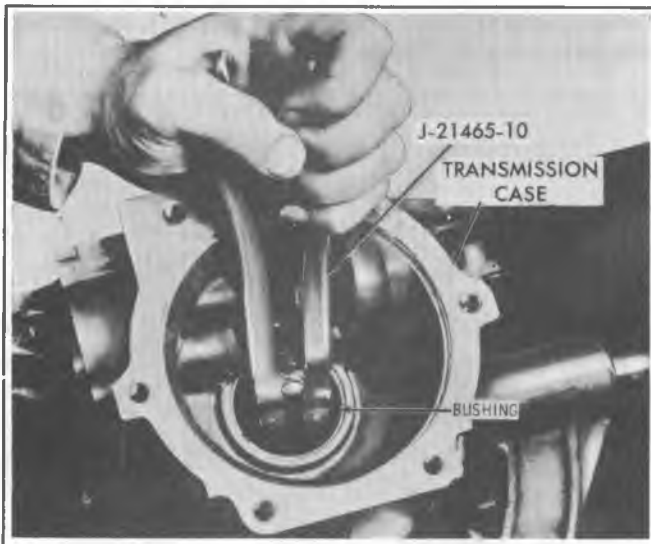

Figure 400-126 Staking Transmission Case Bushing

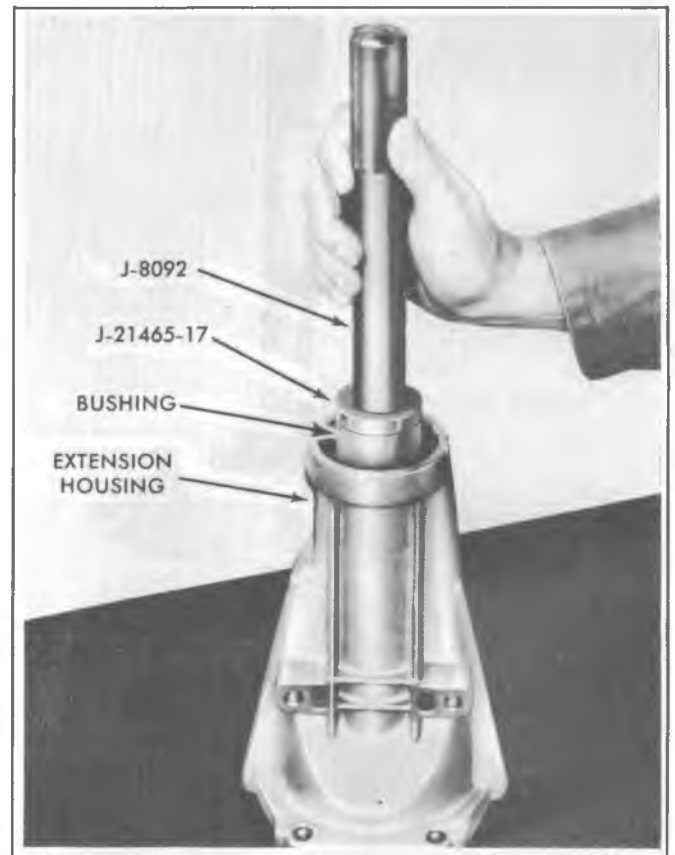

Figure 400-128 Installing Extension Housing Bushing

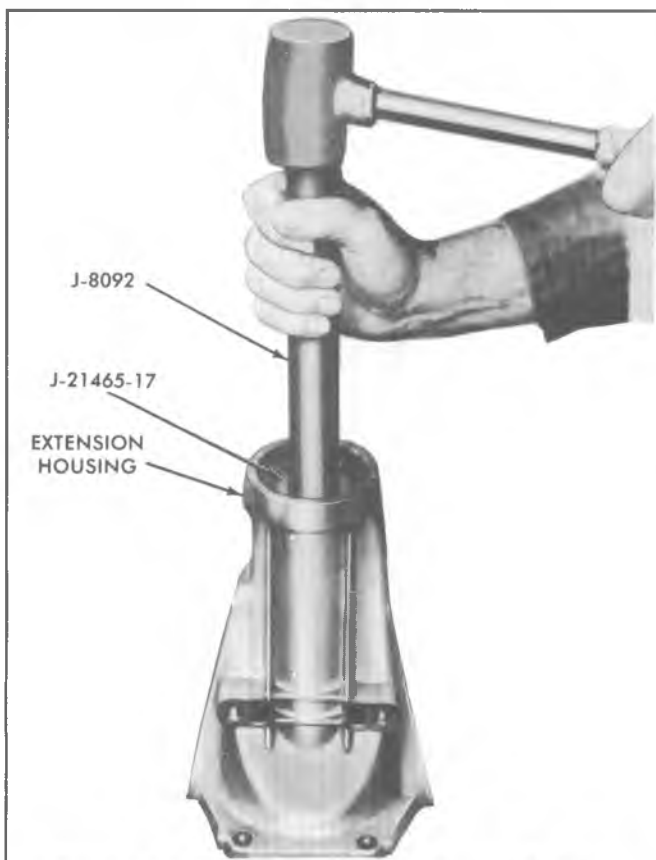

Figure 400-127 Removing Extension Housing Bushing

3. Remove tools and use Tool J-21465-10 to stake bushing in place. Stake marks must be in bushing lubrication grooves. Remove tool and inspect bushing.

Staking in production bushings may or may not be in lubrication grooves. Production equipment does not distort bushing surface making location of stakes optional.

## STATOR SHAFT REAR BUSHING

1. Mount pump cover and stator shaft in vise as shown. Use brass jaws to protect shaft. Assemble Remover J-21465-15 to J-2619 Slide Hammer and J-2619-4 Adapter. Thread

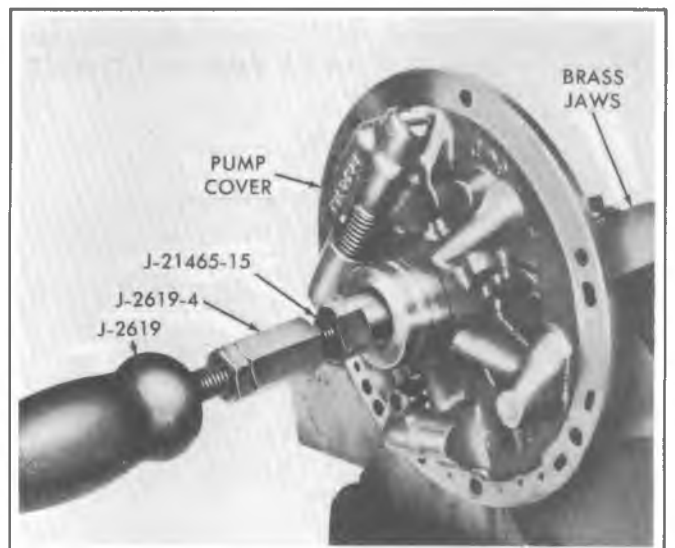

Figure 400-129 Removing Stator Shaft Rear Bushing

2. Clean all shavings from stator shaft bore. Install pump cover in vise supporting shaft on wood block. Assemble Installer J-21465-2 to J-8092 Drive Handle. Install new bushing on shoulder of installer and drive bushing squarely into the bore to a depth of  $19/32$ ", Figure 400-130. Remove tools and inspect bushing.

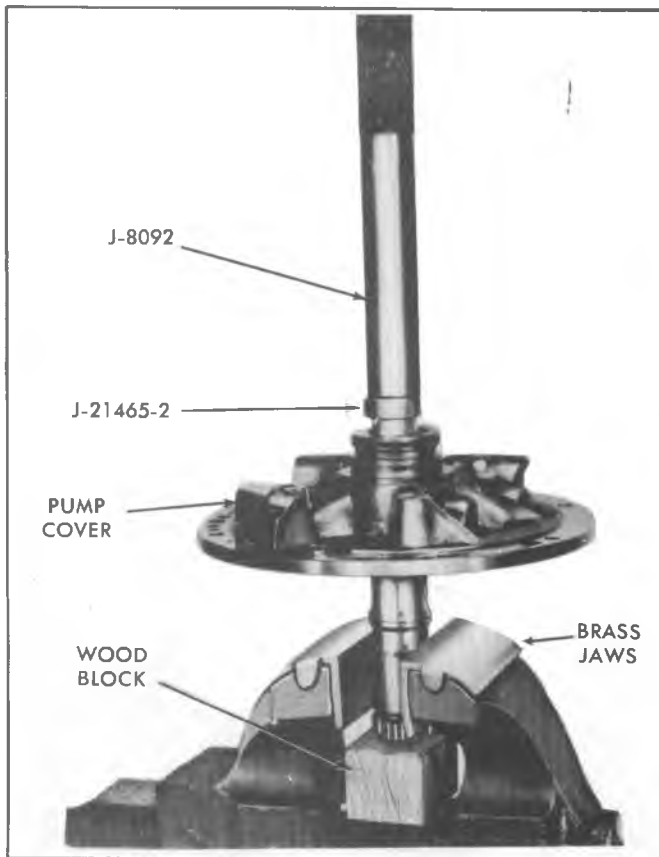

Figure 400-130 Installing Stator Shaft Rear Bushing.

## STATOR SHAFT - FRONT BUSHING

1. Mount pump cover and stator shaft in vise as shown. Use brass jaws to protect shaft. Assemble Slide Hammer J-2619 and Adapter J-2619-4 on Remover J-21465-15.

Thread remover into front bushing and remove bushing with slide hammer, Figure 7A-131.

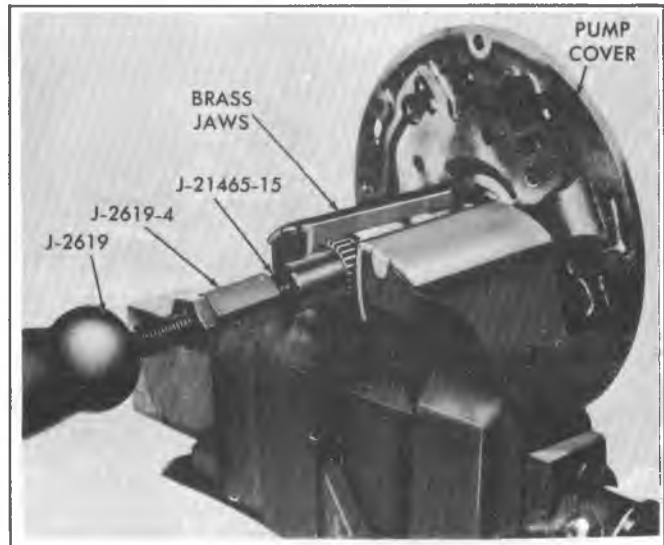

Figure 400-131 Removing Stator Shaft Front Bushing

2. Clean all shavings from stator shaft. Assemble installer J-21465-3 to Drive Handle J-8092. Locate new bushing on shoulder of installer and drive bushing squarely into bore with a lead or brass hammer, as shown in, Figure 400-132. Remove tool and inspect bushing.

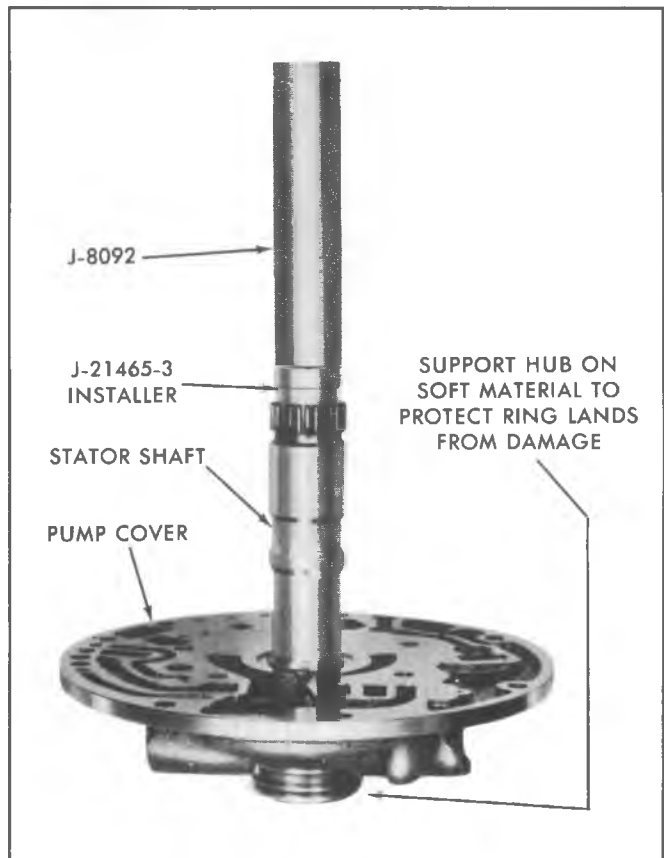
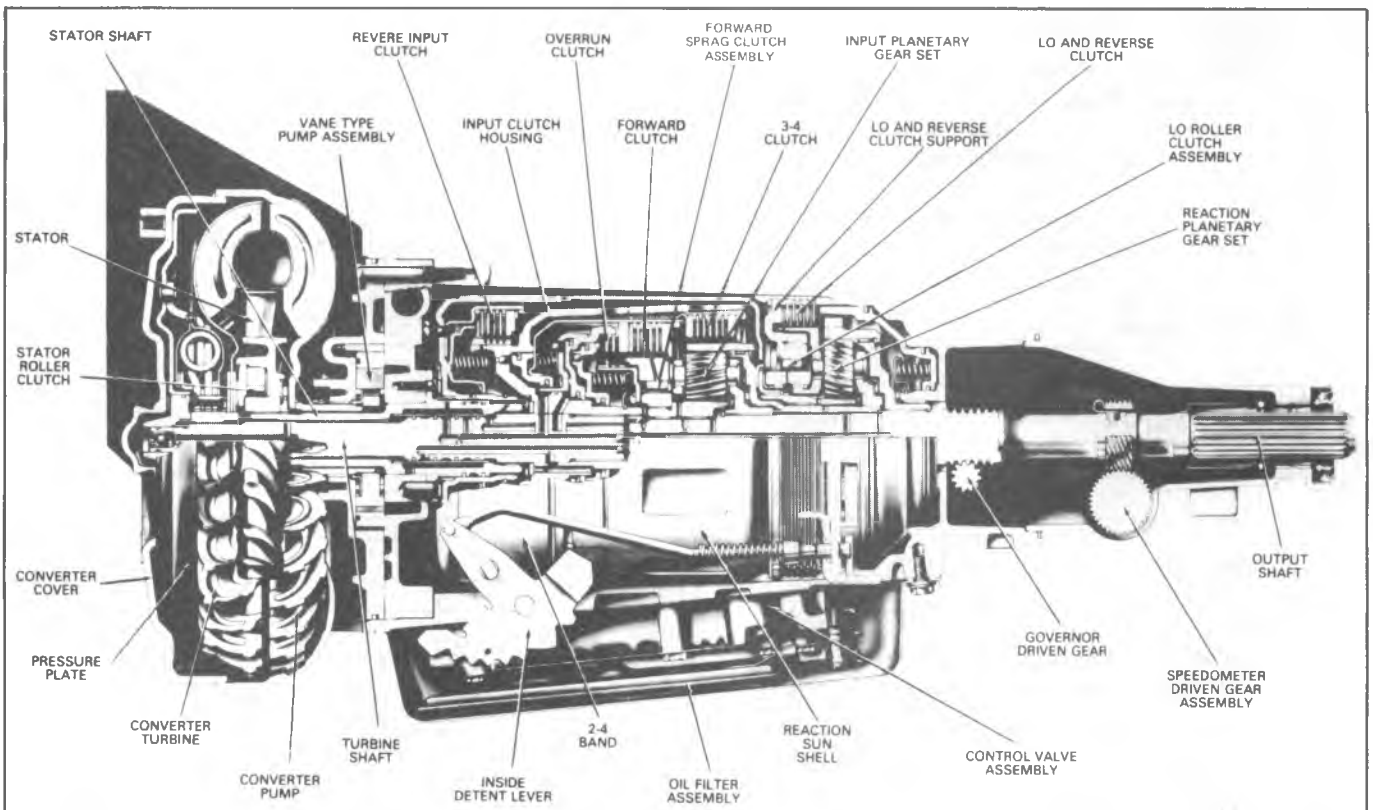

Figure 400-132 Installing Stator Shaft Front Bushing

# SECTION 700-R4

# 700-R4 AUTOMATIC TRANSMISSION CONTENTS

|                                  |       |
|----------------------------------|-------|
| <b>General Description</b> ..... | 7A1-2 |
| <b>Diagnosis Guide</b> .....     | 7A1-5 |
| Oil Pressure.....                | 7A1-5 |
| Shift Points.....                | 7A1-5 |
| Downshifts.....                  | 7A1-7 |
| Converter Diagnosis.....         | 7A1-7 |
| Drives in Neutral.....           | 7A1-7 |
| No Park.....                     | 7A1-7 |
| <b>Transmission Repair</b> ..... | 7A1-8 |



| GEAR RANGE          | 2-4 BAND | REV INPUT CLUTCH | OVERRUN CLUTCH | FORWARD CLUTCH | FORWARD SPRAG CLU ASM | 3-4 CLUTCH | LO ROLLER CLUTCH | LO-REV. CLUTCH |
|---------------------|----------|------------------|----------------|----------------|-----------------------|------------|------------------|----------------|
| 1ST DR <sub>4</sub> |          |                  |                | ON             | ON                    |            | ON               |                |
| 2ND DR <sub>4</sub> | ON       |                  |                | ON             | ON                    |            |                  |                |
| 3RD DR <sub>4</sub> |          |                  |                | ON             | ON                    | ON         |                  |                |
| 4TH DR <sub>4</sub> | ON       |                  |                | ON             |                       | ON         |                  |                |
| 3RD DR <sub>3</sub> |          |                  | ON             | ON             | ON                    | ON         |                  |                |
| 2ND DR <sub>2</sub> | ON       |                  | ON             | ON             | ON                    |            |                  |                |
| 1ST LO              |          |                  | ON             | ON             | ON                    |            | ON               | ON             |
| REV.                |          | ON               |                |                |                       |            |                  | ON             |

Figure 700-R4-1A Transmission Cross Section & Band & Clutch Chart

## GENERAL DESCRIPTION

The model 700-R4 is a fully automatic transmission consisting of a 3-element hydraulic torque converter with the addition of a converter clutch.

Also two planetary gear sets, five multiple-disc type clutches, two roller or one-way clutches and a band are used which provide the friction elements to produce four forward speeds, the last of which is overdrive.

The torque converter, through oil, couples the engine power to the gear sets and hydraulically provides additional torque multiplication when required. Also, through the converter clutch, the converter drive and driven members operate as one unit when applied providing mechanical drive from the engine through the transmission.

The gear ratio changes are fully automatic in relation to vehicle speed and engine torque. Vehicle speed and engine torque are directed to the transmission providing the proper gear ratios for maximum efficiency and performance at all throttle openings.

A hydraulic system pressurized by a variable capacity vane type pump provides the operating pressure required for the operation of the friction elements and automatic controls.

### 700 - GEAR RATIOS

|        |      |         |      |
|--------|------|---------|------|
| FIRST  | 3.06 | FOURTH  | .70  |
| SECOND | 1.62 | REVERSE | 2.29 |
| THIRD  | 1.00 |         |      |

### Minimum T.V. Line Pressure Check

Set the T.V. cable to specification; and with the brakes applied, take the line pressure readings in the ranges and at the engine r.p.m.'s indicated in the chart below.

### Full T.V. Line Pressure Check

Full T.V. line pressure readings are obtained by typing or holding the T.V. cable to the full extent of its travel; and with the brakes applied, take the line pressure readings in the ranges and at the engine r.p.m.'s indicated in the chart below.

**\*NOTICE** Total running time for this combination not to exceed 2 minutes.

**CAUTION** Brakes must be applied at all times.

| AUTOMATIC TRANSMISSION OIL PRESSURES         |                                     |                                     |         |                                  |         |
|--|-------------------------------------|-------------------------------------|---------|----------------------------------|---------|
| MODEL  | RANGE                               | NORMAL OIL PRESSURE AT MINIMUM T.V. |         | NORMAL OIL PRESSURE AT FULL T.V. |         |
|  |                                     | KPA                                 | PSI     | KPA                              | PSI     |
| TE, TH, TJ, TK, T5<br>TW, TC<br>TN, TP<br>YA | PARK & NEUTRAL<br>AT 1000 RPM       | 385-445                             | 55-65   | 880-1,190                        | 130-170 |
|  |                                     | 385-445                             | 55-65   | 880-1,190                        | 130-170 |
|  |                                     | 450-515                             | 65-75   | 890-1,180                        | 130-170 |
|  |                                     | 385-445                             | 55-65   | 880-1,190                        | 130-170 |
| TE, TH, TJ, TK, T5<br>TW, TC<br>TN, TP<br>YA | REVERSE<br>AT 1000 RPM              | 630-730                             | 90-105  | 1,445-1,955                      | 210-285 |
|  |                                     | 630-730                             | 90-105  | 1,445-1,955                      | 210-285 |
|  |                                     | 740-845                             | 110-120 | 1,455-1,940                      | 210-280 |
|  |                                     | 630-730                             | 90-105  | 1,445-1,955                      | 210-285 |
| TE, TH, TJ, TK, T5<br>TW, TC<br>TN, TP<br>YA | DRIVE & MANUAL<br>THIRD AT 1000 RPM | 385-445                             | 55-65   | 880-1,190                        | 130-170 |
|  |                                     | 385-445                             | 55-65   | 880-1,190                        | 130-170 |
|  |                                     | 450-515                             | 65-75   | 890-1,180                        | 130-170 |
|  |                                     | 385-445                             | 55-65   | 880-1,190                        | 130-170 |
| TE, TH, TJ, TK, T5<br>TW, TC<br>TN, TP<br>YA | MANUAL SECOND &<br>LO AT 1000 RPM   | 705-815                             | 100-120 | 705-815                          | 100-120 |
|  |                                     | 705-815                             | 100-120 | 705-815                          | 100-120 |
|  |                                     | 710-810                             | 105-115 | 710-810                          | 105-115 |
|  |                                     | 705-815                             | 100-120 | 705-815                          | 100-120 |

Line pressure is basically controlled by pump output and the pressure regulator valve. In addition, line pressure is boosted in Reverse, Second and Lo by the reverse boost valve.

Also, in the Neutral, Drive, Intermediate and Reverse positions of the selector lever, the line pressure should increase with throttle opening because of the T.V. system. The pressure is controlled by the T.V. cable, the throttle lever and bracket assembly and the T.V. link, as well as the control valve assembly.

The main line pressure tap plug is located on the left side of the transmission above the outside manual lever. H-700R4-109

Figure 700-R4-1-B General Description & Oil Pressure Chart



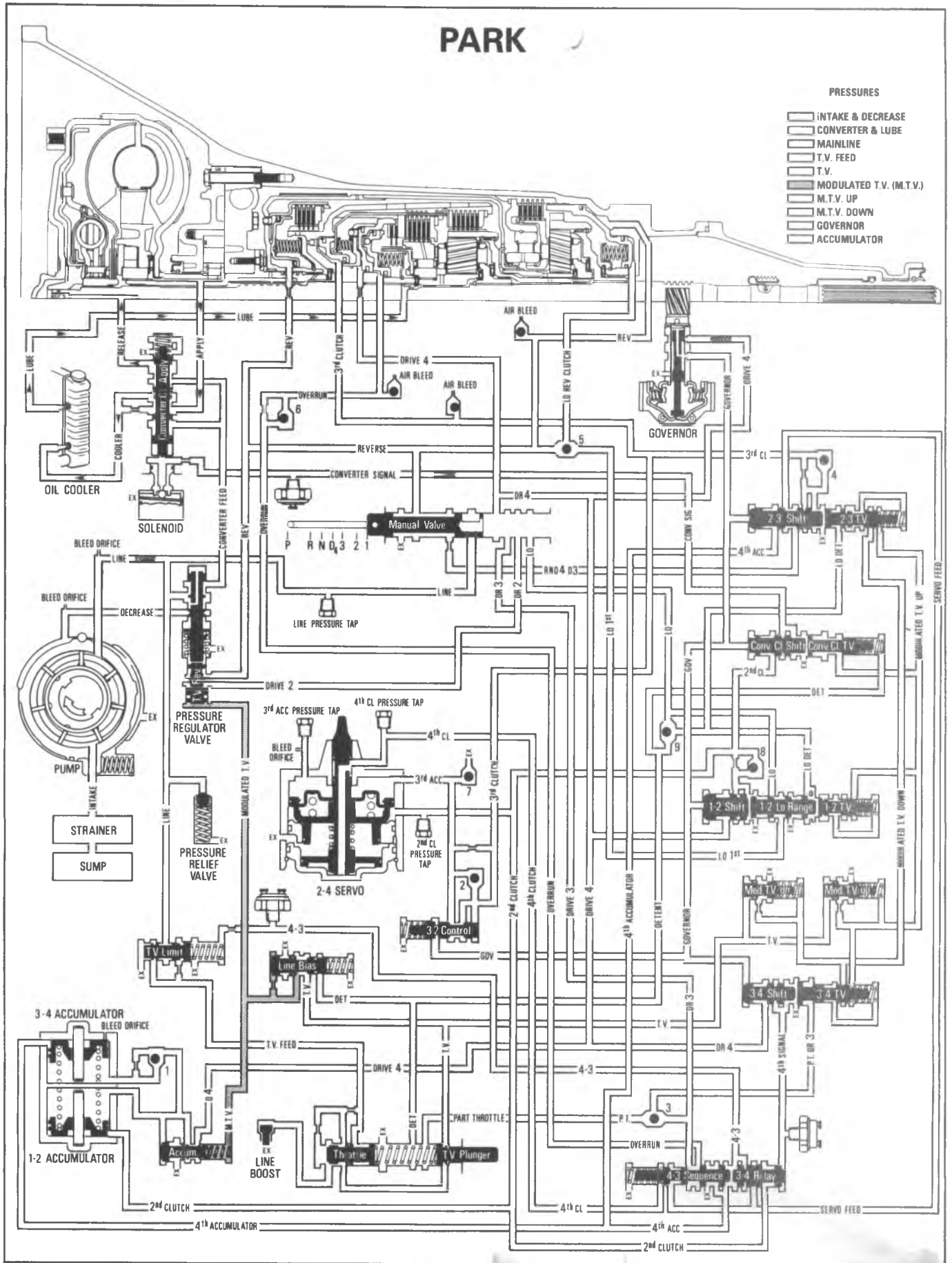
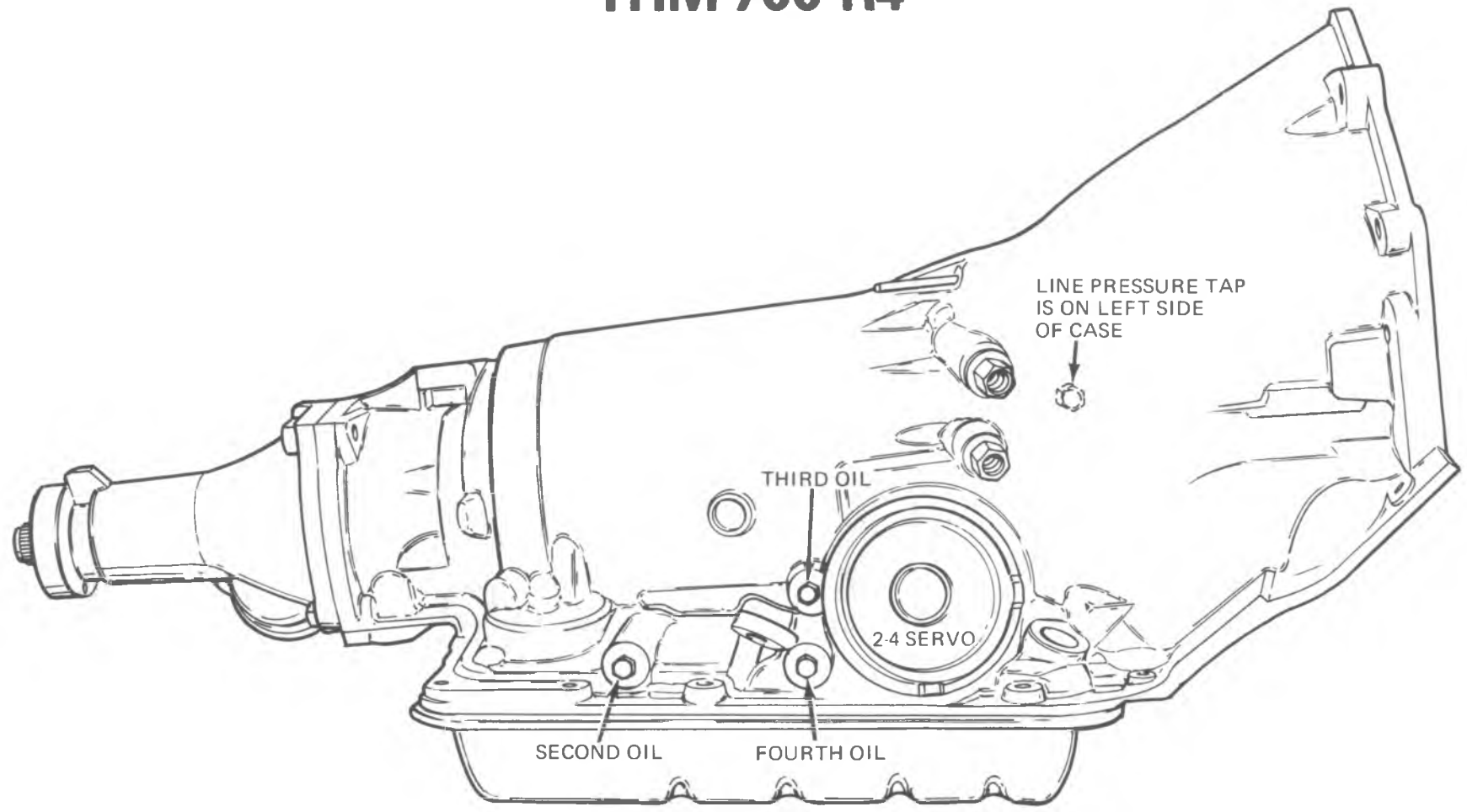

Figure 700-R4-1-C Transmission Oil Circuit Chart - Park Position



# THM 700-R4



OIL PRESSURE TAP LOCATIONS

Figure 700-R4-1-D Oil Pressure Tap Locations

**DIAGNOSIS GUIDE****CHECK: OIL LEVEL****T.V. CABLE****OIL PRESSURE****OIL PRESSURE - HIGH OR LOW****Pump Assembly**

1. Pressure Regulator Valve Binding, Dirt, Damaged Spring.
2. T.V. and Reverse Boost Plugs and Bushings, Dirty, Sticking Damaged or Incorrect Assembly.
3. Pressure Relief Ball Not Seated or Damaged.
4. Slide Sticking
5. Not Regulating
6. Excess Rotor Clearance.

**Manual Valve**

1. Not Engaged, Damaged.

**T.V. Exhaust Valve**

1. Binding, Damaged

**Throttle Lever and Bracket Assembly**

1. Misassembled, Binding, Damaged or Missing Check Valve

**Valve Body**

1. Throttle Valve or Plunger Sticking
2. T.V. Limit Valve Sticking

**Throttle Link**

1. Not Engaged - Damaged - Incorrect - Burr on Upper End - Hanging on T.V. Sleeve

**Filter**

1. Restricted
2. Missing 'O' Ring
3. Hole in Intake Pipe.

**HIGH OR LOW SHIFT POINTS****T.V. Cable**

1. Binding or Not Set

**External Linkage**

1. Improper External Linkage Travel

**Valve Body**

1. Binding Throttle Valve or Plunger
2. T.V. Modulator Up or Down Valve Sticking
3. Gaskets, Spacer Plate Mispositioned or Damaged
4. T.V. Limit Valve Sticking

**Pump Assembly**

1. Sticking Pressure Regulator Valve, or T.V. Boost Valve

2. Pump Slide Sticking

**FIRST SPEED ONLY - NO UPSHIFT****Governor Assembly**

1. Sticking Governor Valve
2. Governor Driven Gear
  - a. Damaged
  - b. Missing Retaining Pin
  - c. Nicks or Burrs on Output Shaft
  - d. Correct Governor Retaining Pin in Case. (Long or Short)
  - e. Governor Sleeve - Burrs
  - f. Case - Burrs
  - g. Governor Weights - and Springs

**Valve Body**

1. 1-2 Shift Valve - Sticking
2. Gaskets, Spacer Plate Mispositioned

**Case**

1. Valve Body Pad - Porosity and or Damaged Lands
2. Governor Screen - Restricted, Damaged
3. 2-4 Servo
  - a. Apply Passages, Servo Pin and Pin Hole in Case.
  - b. Damaged or Missing Servo Piston Seals, Apply Pin Damaged
4. 2-4 Band Assembly
  - a. Burned, Band Anchor Pin Not Engaged. Apply End Broken.

**SLIPS IN 1ST GEAR****Forward Clutch Plates Burned****Forward Clutch**

1. Porosity - Forward Clutch Piston
2. Cut or Damaged Seals
3. Damaged Forward Clutch Housing
4. Internal Leak
5. Forward Clutch Housing Check Ball Damaged
6. Low Oil or Oil Pressure

**Valve Body**

1. Accumulator Valve Sticking
2. Damaged Lands - Interconnected Passages
3. Valve Body Gaskets, Spacer Plate, Damaged Mispositioned

**Binding Internal T.V. Linkage****1-2 Accumulator Piston Assembly**

1. Porous Piston or Bore
2. Cut or Damaged Seals

3. Leak Between Piston and Pin
4. Missing or Broken Accumulator Spring

### 1-2 FULL THROTTLE SHIFTS ONLY

#### T.V. Cable

1. Not Connected
2. Long or Short

#### Throttle Lever and Bracket Assembly

1. Misassembled
2. Binding
3. Missing Exhaust Check Valve

#### Throttle Link

1. Not Connected
2. Burr on Upper End
3. Hanging on Sleeve

#### Throttle Valve or Plunger

1. Hanging or Sticking in Full Open Position

#### Inter Connected Passages

1. Pump - Case - Valve Body

### 1-2 SLIP OR ROUGH

#### Throttle Lever and Bracket Assembly

1. Damaged
2. Incorrectly Installed

#### Valve Body

1. Throttle Valve or Bushing, Sticking
2. Sticking 1-2 Shift Valve Train
3. Gaskets or Spacer Plate Mispositioned
4. Sticking Line Bias Valve
5. Sticking Accumulator Valve
6. Sticking T.V. Limit Valve

### 2-4 Servo

1. Incorrect Servo Apply Pin
2. Damaged Oil Seal Rings or Seals
3. Damaged Bores
4. Restricted or Missing Oil Passages

### 2nd Accumulator

1. Damaged Piston Seal
2. Missing Accumulator Spring
3. Damaged Bores
4. Porous Piston
5. Restricted or Missing Oil Passage

### Burned 2-4 Band

### 2-3 SLIP OR ROUGH

#### Valve Body

1. 2-3 Shift Valve Train Sticking
2. Accumulator Valve Sticking
3. Gaskets or Spacer Plate Mispositioned

4. Throttle Valve Sticking
5. T.V. Limit Valve Sticking

### 3-4 Clutch

1. Burned Clutch Plates
2. Excessive Clutch Plate Travel
3. Cut or Damaged Piston Seals
4. 3-4 Piston Porosity
5. 3-4 Piston Exhaust Ball Open
6. Restricted Apply Passages
7. Check Ball (#7) Capsule Damaged or Misassembled

### 3-4 SLIP OR ROUGH

#### 3-4 Accumulator

1. Missing Accumulator Spring
2. Piston Porosity
3. Restricted Feed Passage
4. Broken Oil Seal Ring
5. Damaged Case Bore

#### Servo

1. Incorrect Band Apply Pin
2. Damaged or Missing Piston Seals
3. Damaged Piston Bores
4. Piston Porosity

### 3-4 Clutch

1. Burned - Refer to 2-3 Slip

### 2-4 Band

1. Burned

#### Valve Body

1. 2-3 Shift Valve Train Sticking
2. Accumulator Valve Sticking
3. Gaskets or Spacer Plate Mispositioned
4. Throttle Valve Sticking
5. T.V. Limit Valve Sticking

### NO REVERSE - OR SLIPS IN REVERSE

#### Forward Clutch

1. Will Not Release

#### Manual Linkage

1. Improperly Adjusted

#### Pump Assembly

1. Reverse Boost Plug - Sticking

#### Valve Body

1. Valve Body Gaskets, Spacer Plate

#### Lo Reverse Clutch

1. Cut or Damaged Piston Seals
2. Restricted or Missing Apply Passage
3. Burned Clutch Plates
4. Cover Plate Loose or Damaged Gasket

**Reverse Input Clutch**

1. Burned Clutch Plates
2. Cut or Damaged Piston Seals
3. Restricted or Missing Apply Passage
4. Housing Exhaust Ball & Capsule Damaged

**NO PART THROTTLE DOWNSHIFTS****Binding External or Internal Linkage****Valve Body**

1. T.V. Modulator Downshift Valve Binding
2. Throttle Valve Binding
3. Throttle Valve Bushing - Feed Hole Restricted or Missing
4. Check Ball #3 Mispositioned

**NO OVERRUN BRAKING - MANUAL 3 - 2 - 1****External Manual Linkage Not Properly Adjusted****Overrun Clutch**

1. Burned Clutch Plates
2. Damaged Inner or Outer Piston Seals
3. Piston Exhaust Ball Sticking or Missing
4. Piston Porosity

**Valve Body**

1. Gaskets or Spacer Plate Mispositioned or Orifice Holes Plugged
2. 4-3 Sequence Valve Sticking
3. Check Balls 3, 9 or 10 Mispositioned

**Turbine Shaft**

1. Restricted or Missing Oil Feed Passage
2. Damaged Teflon Oil Seal Rings
3. Plug Missing

**NO CONVERTER CLUTCH APPLY****Electrical**

1. 12 Volts Not Being Supplied to the Transmission (Refer to the 7A Section)
2. Defective Transmission Outside Electrical Connector
3. Defective Inside Electrical Connector, Wiring Harness, Solenoid
4. Electrical Ground Inside Transmission
5. Defective Pressure Switch or Improper Connection
6. Solenoid Not Grounded

**Valve Body**

1. Sticking Converter Clutch Shift or Throttle Valve
2. Valve Body Casting or Spacer Plate in Converter Clutch Valve Area

**Pump Assembly**

1. Converter Clutch Apply Valve, Stuck or Installed Backwards

2. Signal Oil Orifice, Restricted or Not Present
3. "O" Ring on Solenoid Damaged, Not Installed - Signal Oil Leak
4. Pump to Case Gasket Damaged or Mispositioned
5. Cup Plug Missing from Apply Passage
6. Orifice Plug Missing from the Cooler Input Passage
7. High or Uneven Bolt Torque on Cover to Body
8. Converter Clutch Stop Valve or Retainer Ring Not Installed Properly

**CONVERTER SHUDDER**

1. Converter Clutch Pressure Plate Damaged.
2. Check Ball on End of Turbine Shaft Damaged.
3. Sticking Converter Clutch Shift Valve in Valve Body.
4. Sticking Converter Clutch Apply Valve in Pump.
5. Restricted Converter Clutch Apply Passage.
6. Low Oil or Oil Pressure.
7. Engine Not Tuned Properly.

**NO CONVERTER RELEASE**

1. Converter Clutch Apply Valve Stuck in the Open Position.
2. "O" Ring or Check Ball in the End of the Turbine Shaft Damaged.
3. Internal Converter Damage.

**DRIVES IN NEUTRAL****Forward Clutch**

1. Burned - Not Releasing

**Manual Linkage or Manual Valve**

1. Incorrectly Set
2. Disconnected
3. Internal Linkage

**Case**

1. Interconnected Passages

**2ND SPEED START (DR. RANGE)****Governor Assembly**

2. T.V. Cable

**NO PARK OR WILL NOT HOLD IN PARK**

1. Actuator Rod Assembly Bent or Damaged.
2. Actuator Rod Spring Binding or Improper Crimp.
3. Parking Lock Pawl Return Spring Damaged or Not Assembled Properly.
4. Actuator Rod Not Attached to Inside Detent Lever.
5. Parking Brake Bracket Damaged or Bolts Not Torqued.
6. Inside Detent Lever Nut Not Torqued.
7. Detent Roller Improperly Installed or Damaged.
8. Parking Lock Pawl Binding or Damaged.
9. Parking Lock Pawl Interference with the Lo Reverse Piston.

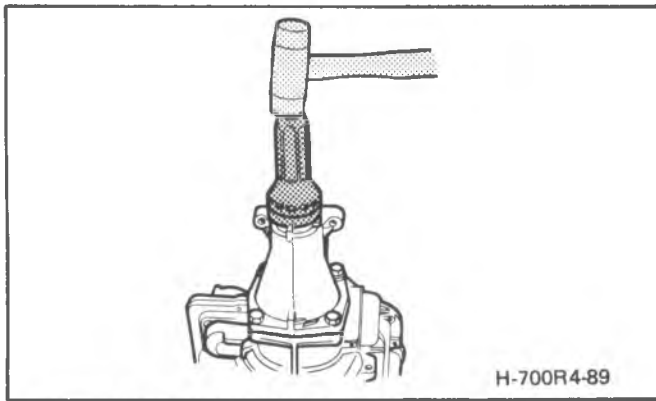

Figure 700-R4-2 Installing Rear Seal with J-21426

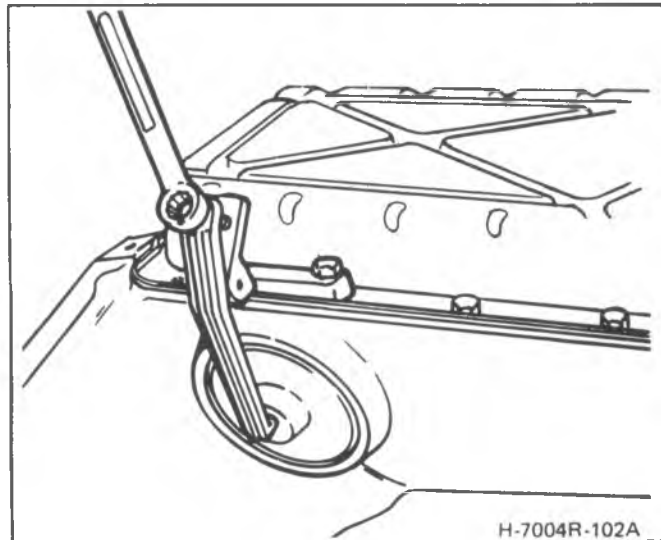

Figure 700-R4-3 Installing or Removing Servo Cover with J-29714

- d. Remove all remaining valve body attaching bolts.
- e. Unhook the manual valve, retaining clip - at the inside detent lever, and remove the valve body assembly, spacer plate, and gaskets.

**3 check balls that are located in the valve body will fall free.**

11. Remove the 3-4 accumulator spring, piston and pin from the transmission case.
12. Remove the 5 check balls and check valve from the case passages.
13. Remove the converter clutch and governor screens from the transmission case.

### TRANSMISSION END PLAY CHECK

1. Position the transmission in a vertical position with the pump side up.
2. Remove a pump to case bolt and washer and install a 278 mm (11") bolt and locking nut.
3. Install J-24773-A and J-25022 securing on the end of the turbine shaft.
4. Mount a dial indicator and clamp on the bolt positioning the indicator point cap nut on the top of J-24773-A. (Fig. 6)
5. With the dial indicator set at zero, pull upwards. The end play should be 0.13 - 0.92 mm (.005 - .036). The selective washer controlling transmission end play is located between the input housing and the thrust washer on the pump hub. If more or less end clearance is required to bring the transmission within

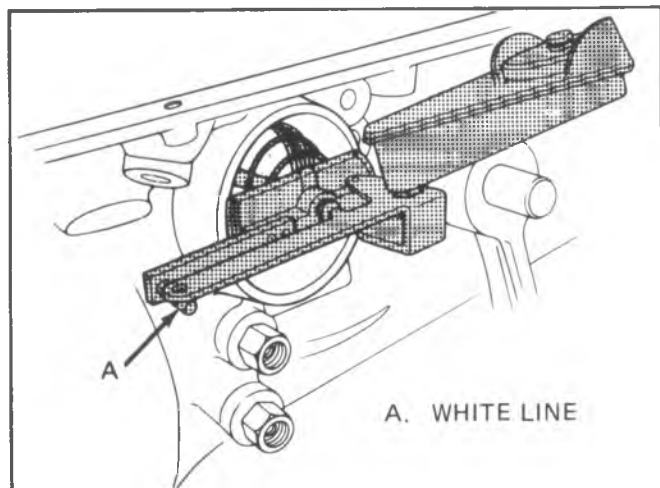

PIN IS PRESET AT FACTORY AND MUST NOT BE READJUSTED

#### 2-4 SERVO PIN SELECTION

| PIN LENGTH  |           | PIN I.D.  |
|-------------|-----------|-----------|
| mm          | INCH      |           |
| 66.37-66.67 | 2.61-2.62 | 2 RINGS   |
| 67.74-68.04 | 2.67-2.68 | 3 RINGS   |
| 69.11-69.41 | 2.72-2.73 | WIDE BAND |

H-7004R-48C

Figure 700-R4-4 2-4 Servo Pin Selection Using J-33037

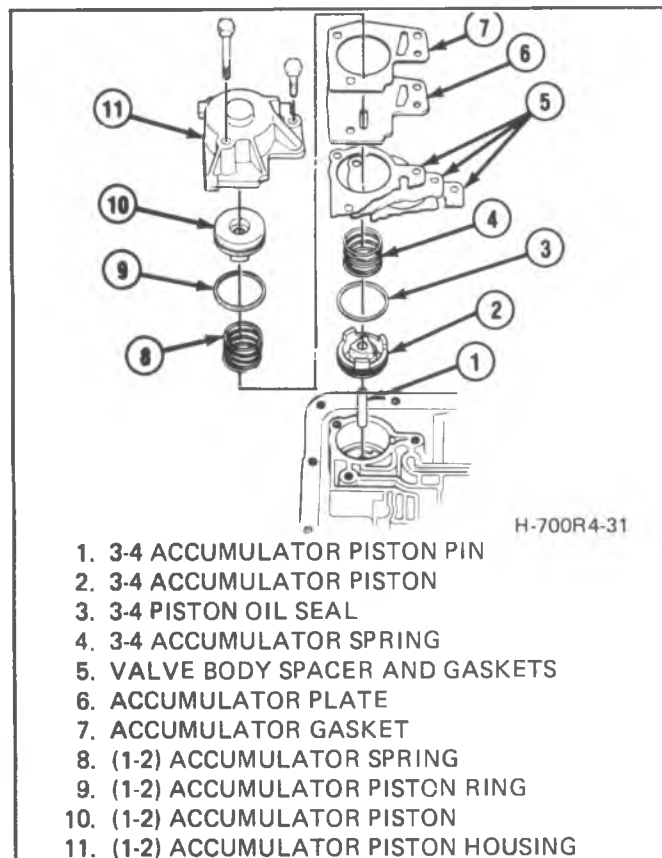

H-700R4-31

1. 3-4 ACCUMULATOR PISTON PIN
2. 3-4 ACCUMULATOR PISTON
3. 3-4 PISTON OIL SEAL
4. 3-4 ACCUMULATOR SPRING
5. VALVE BODY SPACER AND GASKETS
6. ACCUMULATOR PLATE
7. ACCUMULATOR GASKET
8. (1-2) ACCUMULATOR SPRING
9. (1-2) ACCUMULATOR PISTON RING
10. (1-2) ACCUMULATOR PISTON
11. (1-2) ACCUMULATOR PISTON HOUSING

Figure 700-R4-5 1-2 and 3-4 Accumulator Assembly

specifications, select the proper washer from the washer selection chart. (Fig. 7)

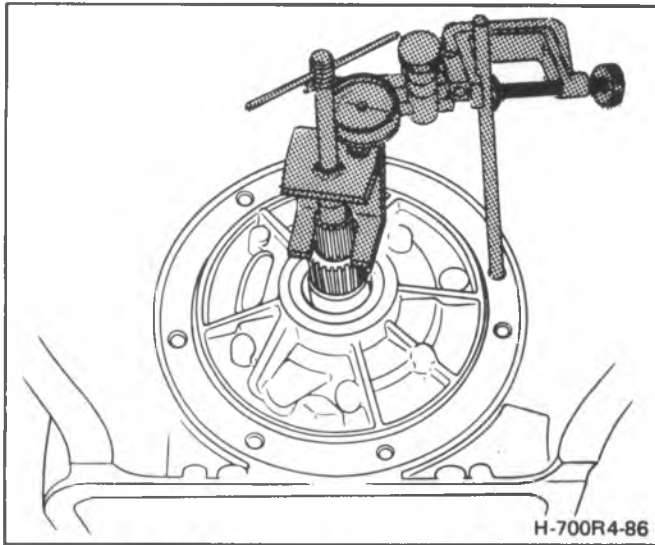

Figure 700-R4-6 End Play Check Using Dial Indicator Set and J-25022 and J-24773A

| TRANSMISSION END PLAY WASHER SELECTION CHART |                 | H-700R4-47 |
|--|-----------------|------------|
| WASHER THICKNESS                             |                 | I.D.       |
| 1.87 - 1.97 mm                               | (.074" - .078") | 67         |
| 2.04 - 2.14 mm                               | (.080" - .084") | 68         |
| 2.21 - 2.31 mm                               | (.087" - .091") | 69         |
| 2.38 - 2.48 mm                               | (.094" - .098") | 70         |
| 2.55 - 2.65 mm                               | (.100" - .104") | 71         |
| 2.72 - 2.82 mm                               | (.107" - .111") | 72         |
| 2.87 - 2.99 mm                               | (.113" - .118") | 73         |
| 3.06 - 3.16 mm                               | (.120" - .124") | 74         |

Figure 700-R4-7 Transmission Selective Washer Chart

- Remove the dial indicator and all tools.

## THE PUMP, REVERSE AND INPUT CLUTCHES

### Removal

- Pump Assembly
  - If required replace the pump seal by removing with a screwdriver and replacing with tool J25016. (Fig. 8)

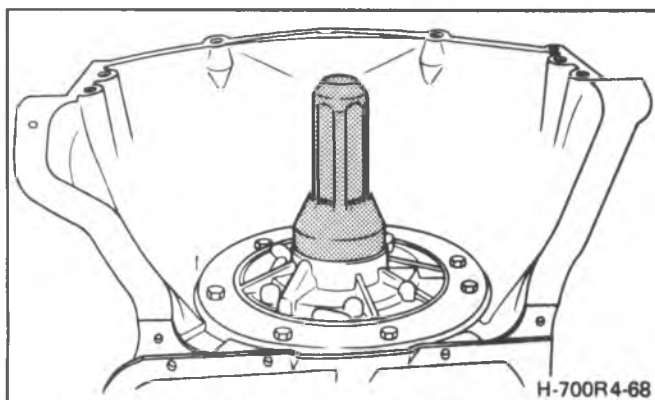

Figure 700-R4-8 Installing Pump Seal with J-25016

- Remove the remaining pump to case bolts and washers.
- Using J-24773-A tool remove the pump assembly and pump to case gasket. (Fig. 9)

The filter and solenoid must be removed before the pump can be removed.

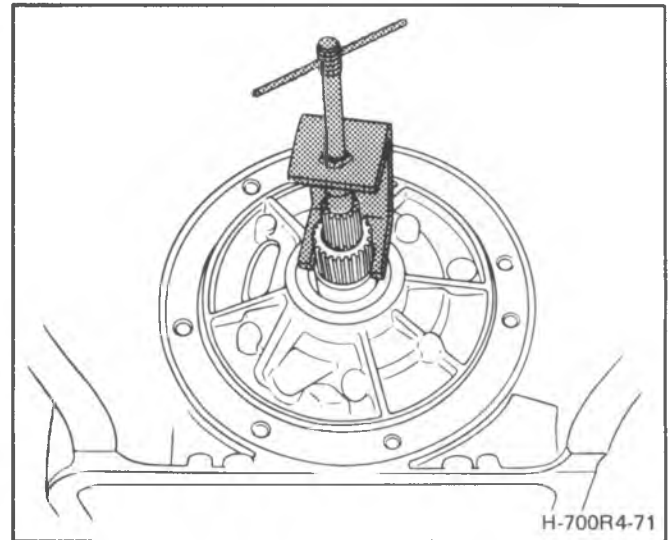

Figure 700-R4-9 Removing Pump Assembly with J-24773-A

- Remove the reverse input drum to pump washer from the pump.
- Remove the reverse and input clutch assemblies by lifting out with the turbine shaft.  
**Do not remove the teflon oil seal rings on turbine shaft unless required.**

## 2-4 BAND AND INPUT GEAR SET

### Removal

- Remove the 2-4 band assembly from the case.
- Remove the band anchor pin from the case.
- Remove the input sun gear.

The output shaft and reaction internal gear assy. are assembled using Loctite to hold the parts as one unit for ease of assembly. During transmission operation, these parts can become separated.

To prevent the possibility of the output shaft falling free, install output shaft support tool J-29837 on the case holding the output shaft in place. (Fig. 10)

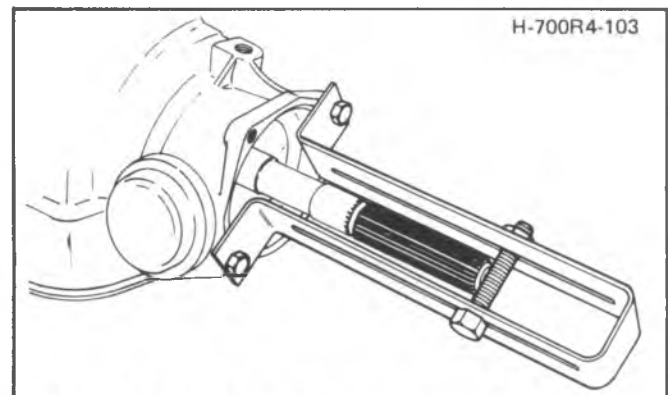

Figure 700-R4-10 Positioning Output Shaft with J-29837

- Remove the input carrier to output shaft snap ring with narrow snap ring pliers.
- If free, remove the output shaft and tool
- Remove the input carrier and thrust washer.

7. Remove the reaction shaft thrust bearing from the input internal gear.

## REACTION GEAR SET

### Removal

1. Remove the reaction shaft to reaction sun gear washer and the reaction shell.
2. Remove the reaction shell to inner race washer.
3. Remove the low and reverse support to case retaining ring and support spring.
4. Remove the reaction sun gear.
5. Remove the low and reverse inner race, roller assembly, and support assembly and reaction carrier assembly.
6. Remove the (5) low and reverse clutch plate assemblies (composition) and (5) low and reverse clutch plates (steel).
7. Remove the reaction internal gear, output shaft if not removed and bearing assembly.
8. Remove the support bearing assembly from the case hub.

## LO AND REVERSE CLUTCH PARTS

### Removal

1. Remove the parking lock bracket and (2) two attaching bolts. If not removed. Position the parking lock pawl inboards.
2. Using tool J-23327, compress the low and reverse clutch spring retainer and remove the spring retaining ring and low and reverse spring assembly.
3. Remove tools.
4. Remove the low and reverse clutch piston by applying air pressure in the case apply passage.

## INNER MANUAL LINKAGE

### Removal

If necessary remove the inner manual linkage as follows:

1. Rotate the transmission to the horizontal position and loosen the manual shaft retaining nut and move inboard on the manual shaft.
2. Move the inner detent lever and connected actuator rod assembly and manual shaft retainer inboard.
3. Gently tap the manual shaft outboard until the retaining nut is free. If necessary install a retaining nut on the outside end of the manual shaft. With a screwdriver remove the manual shaft retainer and connect inner detent lever and actuator rod.
4. Remove the manual shaft and nut.
5. If necessary remove the inside detent lever from the actuator rod assembly by rotating the rod and indexing notches in the rod with the hole in the lever.
6. Inspect the manual shaft seal in the case for damage, and proper location and if necessary replace as follows:
  - a. Using a small screwdriver remove by driving outwards.
  - b. Install a new seal by locating a socket on the outside of the new seal and drive inwards. Make sure the seal is bottomed square against bottom of the case bore and with the open or sealing surface facing inboard. (Fig. 11)

### Inspection

1. Inspect the actuator rod assembly for damage, correctness of shape (not bent).

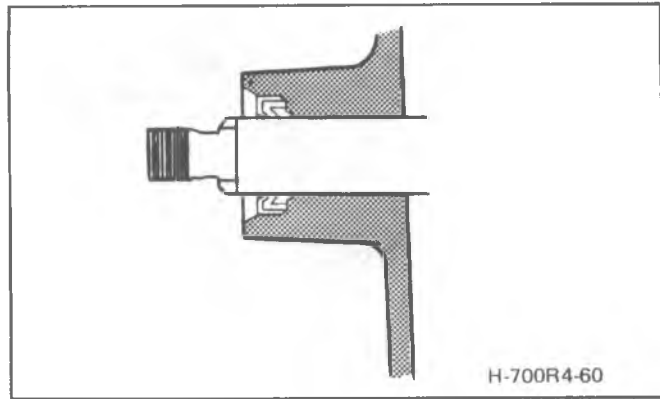

Figure 700-R4-11 Manual Shaft Seal Location

2. Inspect the actuator rod spring for freeness of action, distortion.
3. Inspect the inside detent lever for damage or cracks.
4. Inspect the manual shaft for damage and burrs.

### Assembly

(Fig. 12)

1. If removed, connect the parking lock actuator assembly to the inside detent lever by indexing the notches on the actuator rod with the slot on lever.
2. Install the outer manual shaft part way into the case with the long pin end first.
3. On the outer manual shaft loosely install the manual shaft retainer the inside detent lever with the small ear inboard and the attached actuator rod assembly. Position the end of the actuator rod on the outside side of the parking lock pawl and on the inside of the bracket.
4. Install the manual shaft retaining nut on the manual shaft, do not engage threads.
5. Gently tap the outer manual shaft into the case.
6. Indexing the slot in the outside detent lever and the manual the shaft engaging threads and torque to 31 N·m (23 ft. lbs.).

**Check for proper operation of assembly by rotating the inside manual lever and observing the operation of the parking lock parts.**

## PARKING PAWL AND RETURN SPRING

### Removal

If necessary, the parking pawl and return spring can be removed as follows:

1. With an "easy out" remove parking lock shaft retaining plug from the outside of the case.
2. Remove the parking lock shaft, pawl and return spring.

### Inspection

1. Inspect the parking lock pawl for hairline cracks, burrs, or other damage.
2. Inspect the parking lock return spring for distortion, or damage.
3. Inspect the parking lock shaft for damage and freeness of fit with the pawl.

### Assembly

1. Position the return spring on the parking lock pawl so the long end of the spring is inboard pushing the pawl outward.

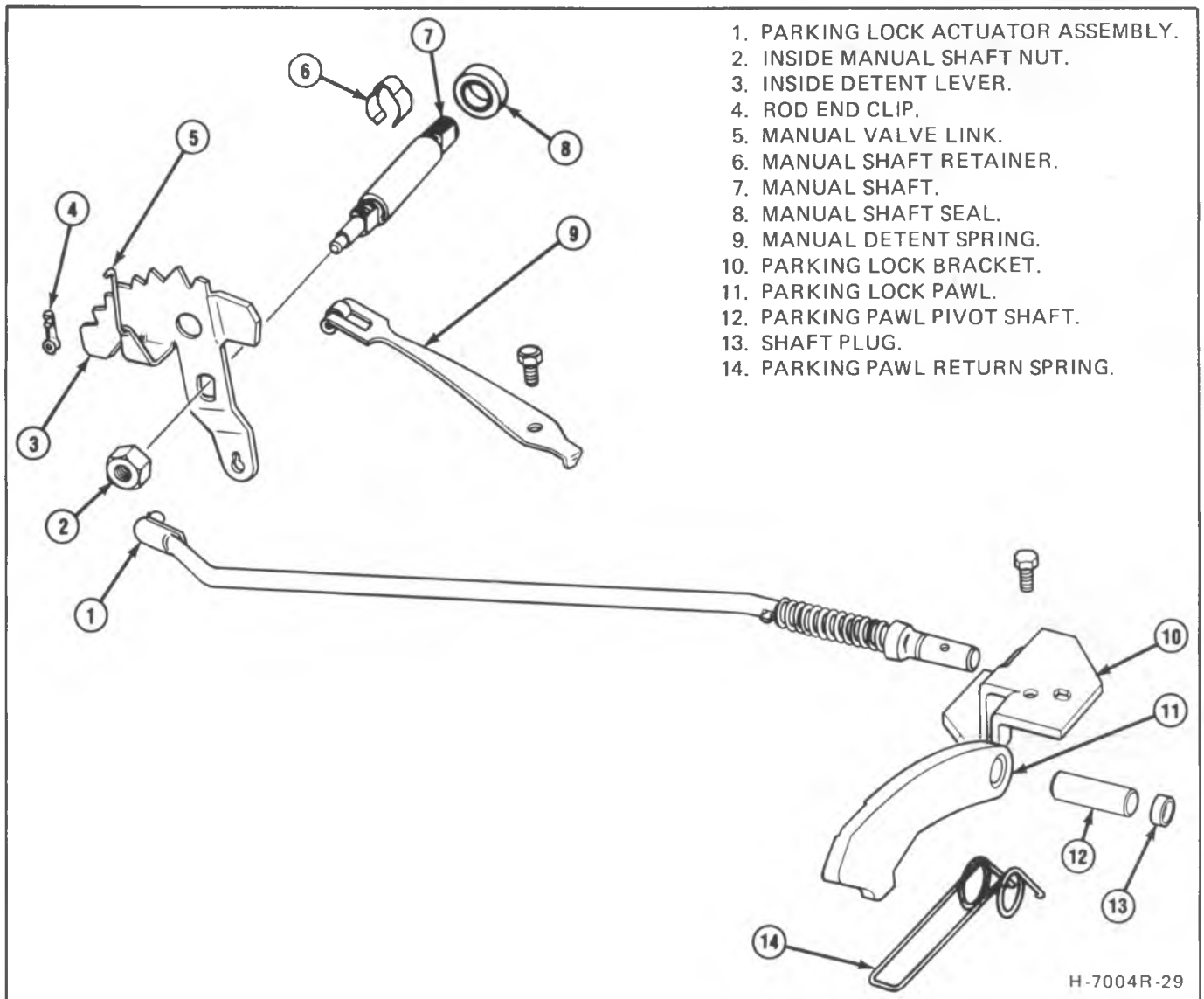

Figure 700-R4-12 Parking Lock Linkage

H-7004R-29

2. Locate the pawl and spring in the case and install the parking lock shaft.  
**Check for proper operation.**
3. Install the retaining plug with loctite sealer in the case with a punch.

7. Inspect the cooler line connectors for damage and proper torque.
8. Inspect all snap ring grooves for damage.
9. Inspect the governor locating pin for proper length. A incorrect length results in a damaged governor gear. (Fig. 14)

## CASE AND ATTACHING PARTS

### Inspection

1. Inspect the case for damage, cracks, porosity or interconnected oil passages. (Fig. 13)
2. Inspect the valve body case pad for flatness or land damage. The oil passage lands are considered acceptable if a void exists and is not in excess of 50% of the land. The condition of the valve body pad can also be checked by inspecting the mating face of the spacer plate to case gasket for a proper case land impression.
3. Air check the case passages for restrictions or blockage.
4. Inspect the case internal clutch plate lugs for damage, or wear.
5. Inspect the speedo, servo and accumulator bores for damage and clearance relative to the mating parts.
6. Inspect all bolt holes for damaged threads. Helo-coils can be used for repair.

## 3RD ACCUMULATOR CHECK VALVE

Inspect the 3rd accumulator check valve for the following conditions: Missing ball check, ball binding or stuck in the sleeve, the oil feed slot in sleeve missing or restricted, improperly assembled, loose fitting or not fully seated in the case or damaged. (Fig. 15)

If the 3rd accumulator check valve assembly requires replacement, perform the following:

1. Using a 6.3 (#4) easy out, remove the check valve assembly from the case by turning and pulling straight out.
2. Install a new check valve assembly, small end first, into the case. Positioning the oil feed slot in the sleeve so that it aligns with servo oil passage (Fig. 15).
3. Scribe a mark at 42.0 mm on a 9.5 mm (9/8") diameter metal rod and use it to seat the check valve assembly.



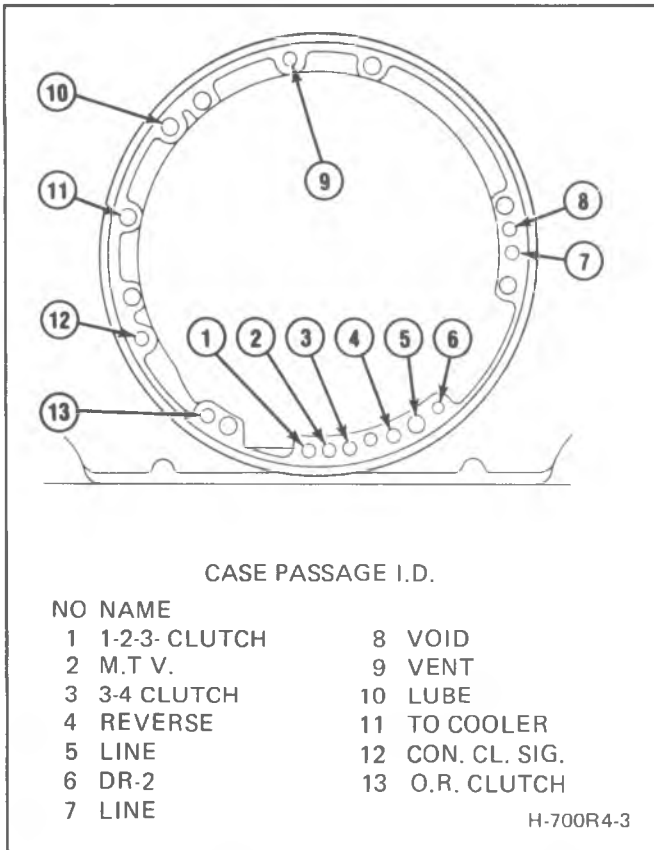

Figure 700-R4-13 Pump to Case Oil Passages

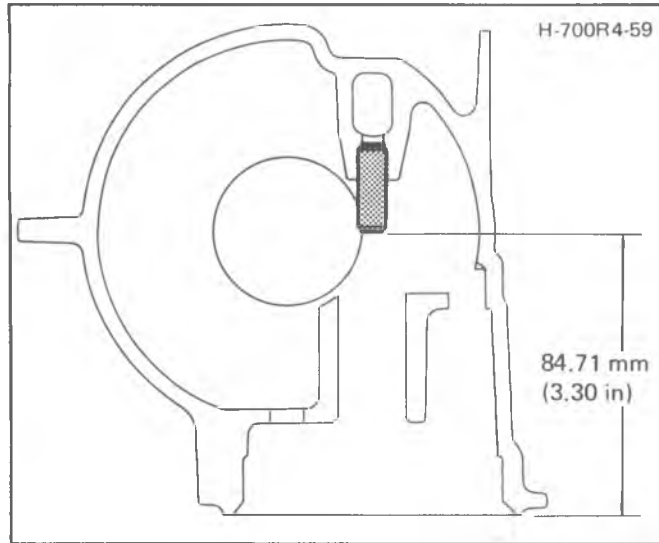

Figure 700-R4-14 Governor Pin Location

Drive the check valve assembly into the case until the scribe mark is flush with the case. (Fig. 16)

## GOVERNOR ASSEMBLY

### Inspection

1. Wash all parts in cleaning solvent, air dry and blow out passages.
2. Inspect the governor body and valve for free operation, nicks, burrs, scoring or galling.
3. Inspect the driven gear for nicks, damage or excessive looseness.
4. Inspect the governor weight springs for distortion.

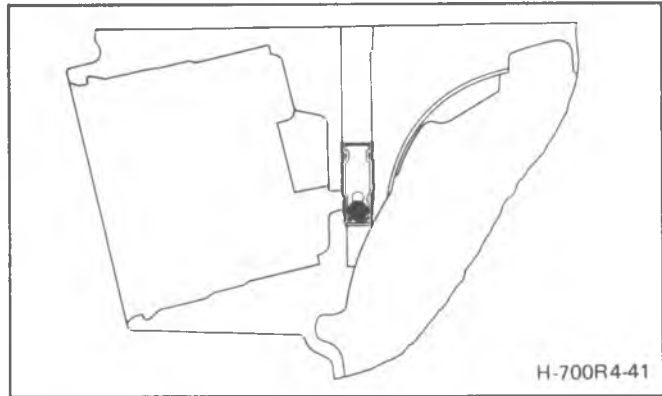

Figure 700-R4-15 3rd Accumulator Check Ball Location

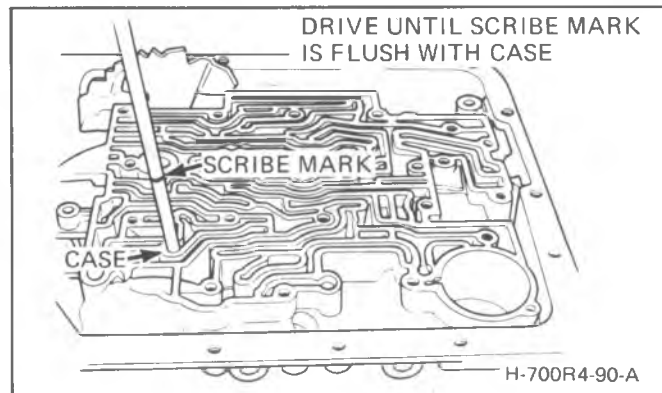

Figure 700-R4-16 Installing the 3rd Accumulator Check Ball Assembly

### Disassembly

(Fig. 17)

The governor assembly should be disassembled when the governor drive gear requires replacement or if the valve is sticking and requires cleaning.

1. Cut off one end of each governor weight pin and remove the pins, outer and secondary weights.
2. Remove the governor valve from the governor sleeve.
3. Inspect and replace the governor drive gear if required.
  - (a) Drive out the governor gear retaining pin, using a small punch.
  - (b) Support the governor assembly on plates installed in the exhaust slots of the governor sleeve. Place in an arbor press and with a long punch, press the gear out of the sleeve.
  - (c) Clean the governor sleeve of any chips that might be present.

### Assembly

- (a) Support the governor on plates, installed in the exhaust slots of the sleeve. Position a new gear on the sleeve and press the gear into the sleeve until it is seated against the shoulder.
- (b) A new pin hole must be drilled through the sleeve and gear. Locate the new hole position 90 degrees from the existing hole. While supporting the governor in press, center punch and drill a new hole through the sleeve and gear using a standard 1/8 inch drill.
- (c) Install the retaining pin and stake in two locations and thoroughly wash.

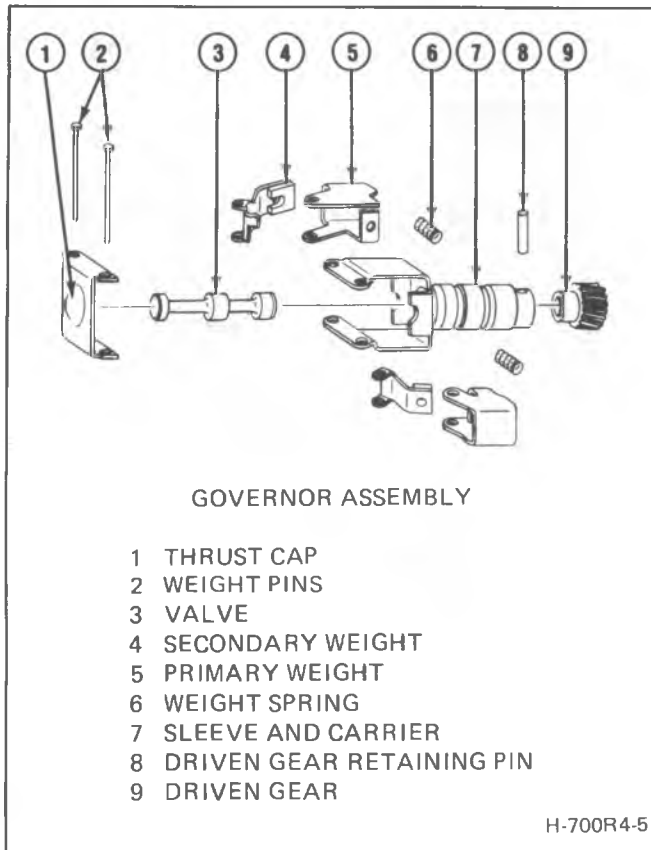

Figure 700-R4-17 Governor Assembly

## CASE ATTACHING PARTS

### Inspection

1. Inspect the 1-2 and 3-4 accumulator parts for the following:
  - a. Porosity or damage in the pistons, housing or oil seal rings.
  - b. Damaged or distorted oil seal rings and pins.
  - c. Clearance or freeness of the pistons to the pins.
  - d. Flatness and condition of the accumulator and oil passage plate and gasket.
2. Wiring Harness
  - a. Inspect the wire leads and connectors for damage or exposed wires.
  - b. Inspect the "O" Ring for damage.
  - c. Inspect the coil and all connections for damage.
3. Speedo gear and clip
  - a. Inspect the speedo gear and clip for tooth damage or distortion.
4. Throttle lever and bracket assy. (Fig. 18)

## REACTION AND INPUT GEAR SETS AND LOW REVERSE CLUTCH AND SUPPORT

### Inspection

1. Inspect the reaction and input carriers for pinion gear damage, excessive wear, incorrect number of pinion pin washers and proper staking of the pinion pins.
2. Inspect the captive bearings of the carrier for excessive heat damage, flatness, and roller condition by rotating the top thrust washer.
3. Inspect the sun and internal gears and supports for tooth condition and bushing wear. If necessary, remove the retaining rings of the internal gears.

4. Inspect all snap rings for damage or distortion.
5. Inspect the low reverse clutch plates for damage or burning.

**The steel plates can indicate some discoloration. The composition plates can be dark in color and be satisfactory. Inspect for flaking, scoring or wear (thickness).**

6. Remove the seals from the low reverse piston and inspect for damage and condition. Reinstall the seals or replace as required.
7. Inspect the low reverse piston for damage or porosity.
8. Inspect the low reverse spring retainer and springs for flatness or distortion.
9. Inspect all thrust washers for surface finish or damage.

## LOW REVERSE SUPPORT ASSEMBLY

### Disassembly

1. Remove the low reverse inner race if not removed.
2. Remove one snap ring retaining the roller assembly to the support.
3. Remove the roller assembly.

### Inspection

1. Inspect the inner and outer races for damage and surface finish.
2. Inspect the roller and springs for damage or distortion.

### Assembly

(Fig. 19)

1. Position the low reverse support on the bench so that the chamfered side is up.
2. Install the low reverse roller assembly into the support with the oil lube hole down or rearward.

**Care should be taken to insure that the rollers and spring are not damaged and that the rollers do not become dislodged.**

3. Install the low reverse inner race into the roller assembly by rotating clockwise.

**When installed, the inner race should rotate in the clockwise direction and lock up in the counterclockwise direction.**

## TRANSMISSION ASSEMBLY

### LOW REVERSE CLUTCH

(Fig. 20)

### Assembly

1. Position the transmission in a vertical position.
2. Lubricate and install the inner, center, and outer seals on the low reverse clutch piston if removed. (Large aluminum).
3. Install the low reverse clutch piston in the transmission case indexing the piston with the notch at the bottom of the case with the hub facing downward, making certain the piston is fully seated in the downward position and the parking pawl will index into the opening in the piston wall.
4. Install the low reverse clutch spring retainer assembly into the case with the flat side of the retainer upwards.
5. Install tool J-23327 and compress the springs, indexing the tool retaining plate so that the tool is free to slide over the case hub.
6. Install the low reverse clutch snap ring and remove all tools.

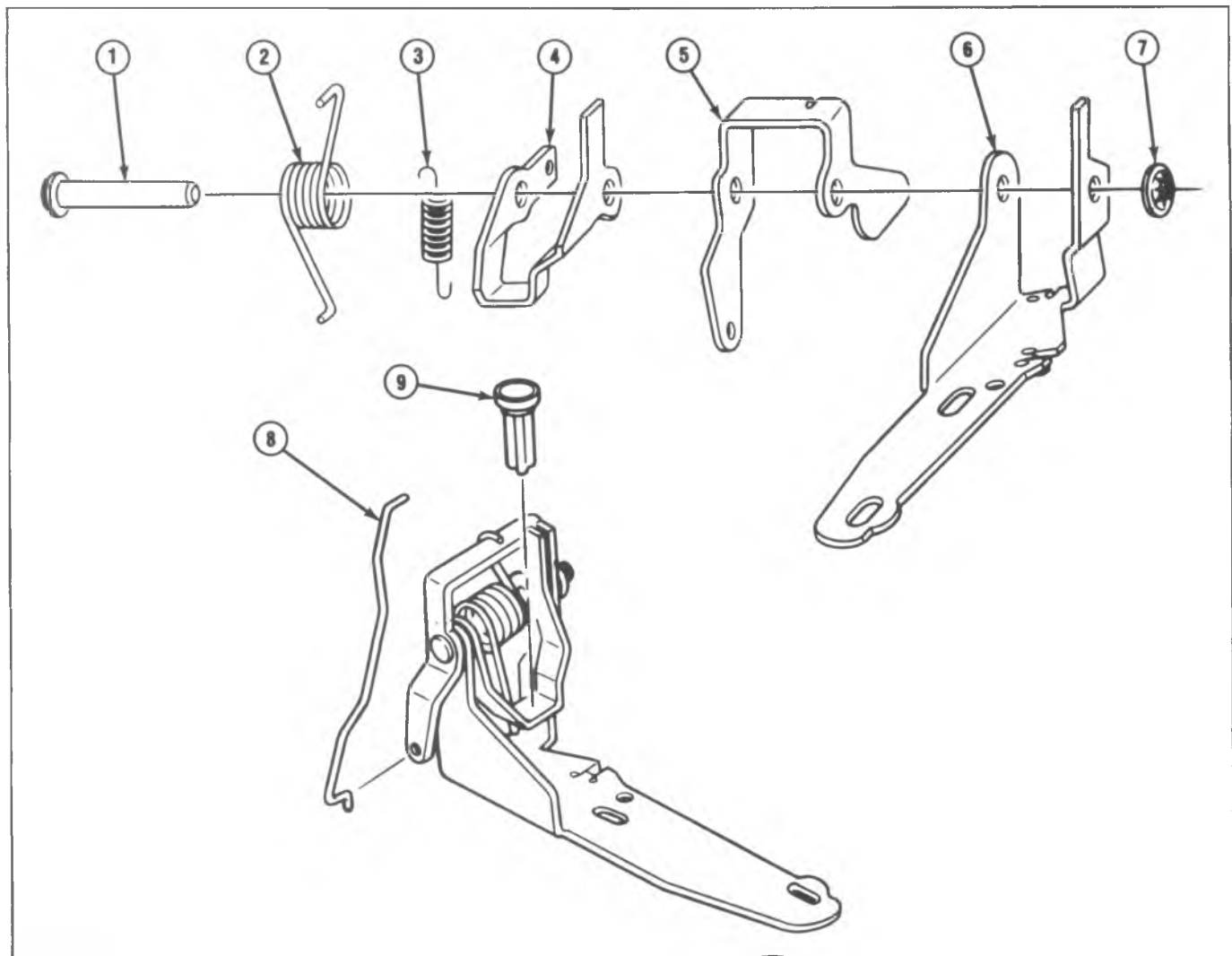

- 1. PIN
- 2. LINE BOOST SPRING
- 3. TORSION LEVER SPRING
- 4. LINE BOOST LEVER
- 5. THROTTLE LEVER

- 6. THROTTLE BRACKET
- 7. RETAINING NUT
- 8. THROTTLE LINK
- 9. EXHAUST VALVE

INSPECT THE THROTTLE LEVER AND BRACKET ASSEMBLY FOR STICKING, BINDING OR DAMAGE. ALSO MAKE CERTAIN THE OPERATION IS FREE AND WITHOUT RESTRICTIONS. IF ANY PARTS REQUIRE REPLACEMENT, PROCEED AS FOLLOWS.

**DISASSEMBLY**

1. UNHOOK AND REMOVE THE LINE BOOST SPRING
2. REMOVE THE RETAINING NUT FROM THE PIN.

3. REMOVE THE PIN, TORSION LEVER SPRING, LINE BOOST LEVER, THROTTLE LEVER AND BRACKET

**ASSEMBLY**

1. POSITION ALL THROTTLE BRACKET PARTS AS SHOWN, INDEXING WITH A SMALL PUNCH.

LEAVE THE SHORT END OF THE TORSION LEVER SPRING UNHOOKED AND REARWARD OF THE TOP THROTTLE LEVER. ASSEMBLY IS DIFFICULT WITH SPRING TENSION.

2. INSTALL THE PIN AS SHOWN, AND AT THE SAME TIME REMOVE THE PUNCH.

3. POSITION THE SHORT END OF THE LOOSE TORSION SPRING UNDER THE BRACKET AND LOCATE IN NOTCH

4. INSTALL THE RETAINING NUT ON THE END OF THE PIN

Figure 700-R4-18 Throttle Lever and Bracket Assembly

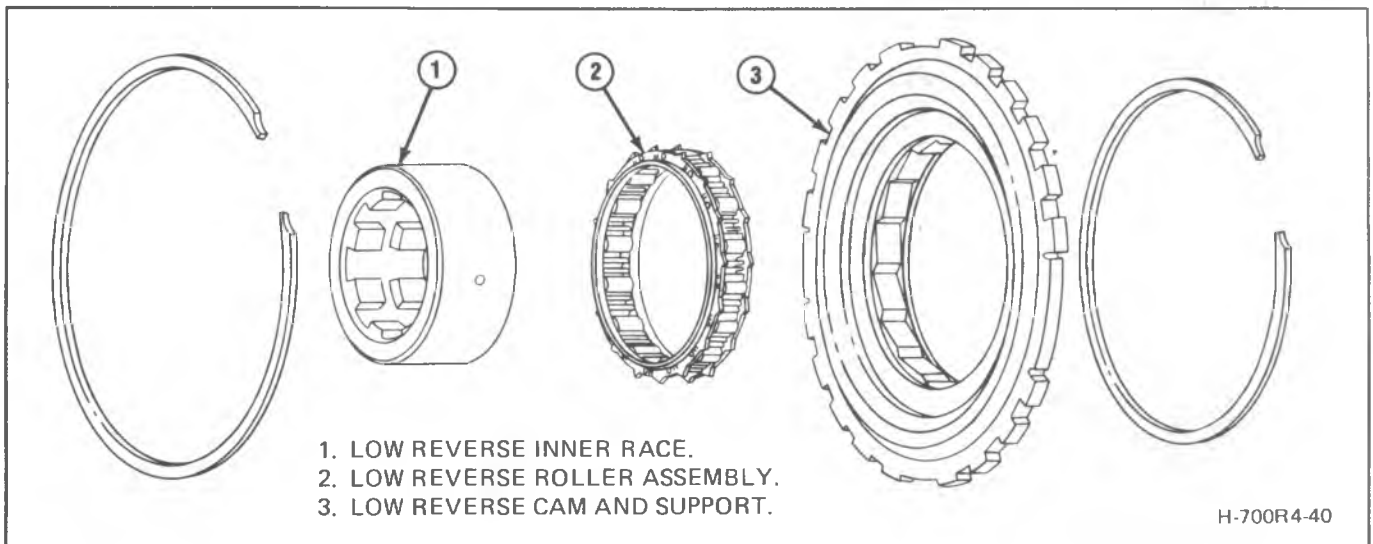

Figure 700-R4-19 Low Reverse Clutch Support Assembly

7. Install the reaction internal gear support bearing on the case hub so that the longer inside "L" race is positioned downward. (Fig. 21)
8. Install the reaction internal gear and output shaft on the bearing assembly in the case. When the gear is properly seated it will be centered with the long open slot in the case and the parking lock pawl can be engaged with the external teeth of the internal gear.
 

**If the reaction internal gear and output shaft were removed as one unit, install into the case at this time, otherwise assemble only the reaction internal gear.**
9. Install the reaction carrier to support thrust bearing on the internal gear support so that the longer outside "L" race is positioned downwards.
10. Install the reaction carrier (with large outside hub) locating the reverse hub upwards.
11. Install the low and reverse clutch plates, starting with steel and alternating with composition (5 steel and 5 composition) indexing with the splines of the reaction carrier and case, aligning the steel plates. (Figs. 22 & 24)
12. Remove the low reverse inner race and install the low reverse support and roller assembly with the chamfered side up in the case, indexing with the case splines. (Fig. 23)
13. Install the low reverse inner race into the roller assembly and rotate until the internal splines are engaged, then push downward for full engagement. The bottom tanges will be flush with the reaction hub when seated.
14. Install the low reverse snap ring and support spring into the transmission case.
4. Install the reaction shaft to shell thrust washer indexing the tangs in the shell. (Bronze thrust washer with wide thrust face).
5. Install the input internal gear and shaft positioning the shaft end first.
 

**If the output shaft and reaction gear were removed as separate parts during disassembly, the following procedures must be used.**

  - a) Position the output shaft into the transmission, indexing with all parts.
  - b) Install the output shaft support tool J-29837 and adjust so that the output shaft is positioned upwards as far as possible. (Fig. 26)
6. Install the input carrier to reaction shaft thrust bearing with the long "L" race on the outside. (Fig. 25)
7. Install the input carrier assembly, with the hub end down.
8. Install a new snap ring on the output shaft.
9. Install the input sun gear, indexing the gear end with the input carrier pinions.
10. Install the input carrier thrust washer on the input carrier.

## THE REACTION AND INPUT GEAR SETS

### Assembly

1. Install the snap ring on the reaction sun gear if removed, and install into the reaction carrier indexing the pinions.
2. Install the nylon low reverse thrust washer with 4 locating ears on the low, reverse inner race. (Fig. 25)
3. Install the reaction sun gear shell (large housing with end slots and holes) engaging the splines of the shell shaft and the sun gear.

## REVERSE INPUT AND INPUT CLUTCH ASSEMBLIES

### Disassembly

(Fig. 27)

1. Remove the reverse input clutch from the input clutch assembly by lifting upwards.
2. Remove the stator bearing and selective washer from the input housing.

## REVERSE INPUT CLUTCH

### Disassembly

1. Remove the snap ring from the reverse input housing.
2. Remove the reverse input clutch backing plate.
3. Remove the reverse input steel and composition clutch plates.
4. Using tool J-23327 compress the reverse input spring assembly and remove the snap ring. (Fig. 28)
5. Remove all tools.
6. Remove the reverse input clutch release spring assembly.

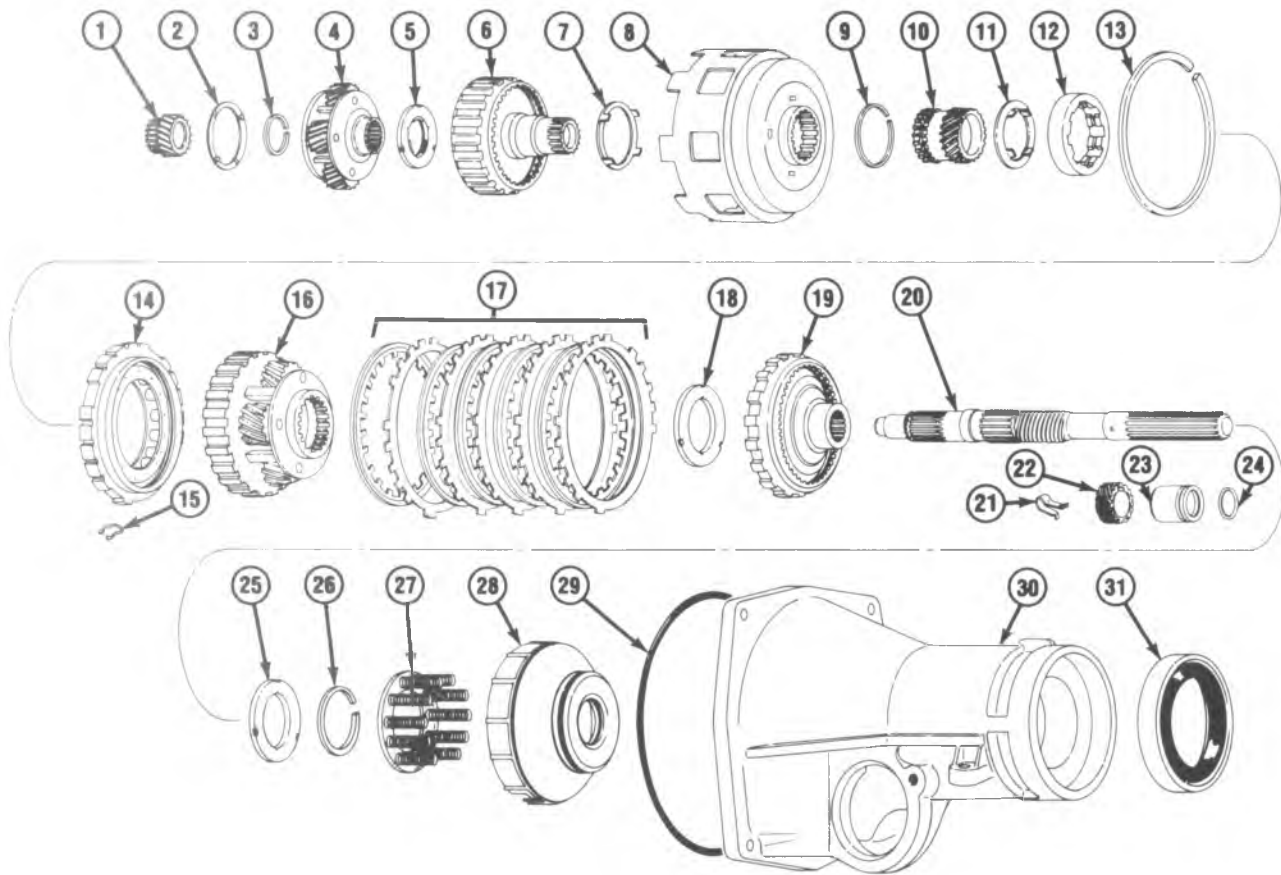

- |   |   |
|---|---|
| 1. INPUT SUN GEAR.                          | 16. REACTION CARRIER                      |
| 2. INPUT CARRIER THRUST WASHER              | 17. LO REVERSE CLUTCH PLATES              |
| 3. OUTPUT SHAFT TO INPUT CARRIER SNAP RING  | 18. REACTION GEAR SUPPORT BEARING         |
| 4. INPUT CARRIER ASSEMBLY                   | 19. REACTION INTERNAL GEAR AND SUPPORT    |
| 5. INPUT CARRIER TO REACTION SHAFT BEARING  | 20. OUTPUT SHAFT                          |
| 6. INPUT INTERNAL GEAR AND SUPPORT ASSEMBLY | 21. SPEEDO GEAR RETAINER                  |
| 7. REACTION SHAFT SHELL THRUST WASHER       | 22. SPEEDO DRIVE GEAR                     |
| 8. REACTION SUN GEAR SHELL                  | 23. OUTPUT SHAFT SLEEVE                   |
| 9. REACTION SUN GEAR SNAP RING              | 24. OUTPUT SHAFT SEAL                     |
| 10. REACTION SUN GEAR                       | 25. REACTION GEAR SUPPORT TO CASE BEARING |
| 11. RACE TO SHELL THRUST WASHER             | 26. LO REVERSE SPRING RETAINER            |
| 12. LO REVERSE INNER RACE                   | 27. LO REVERSE CLUTCH SPRING ASSEMBLY     |
| 13. LO REVERSE CLUTCH SUPPORT SNAP RING     | 28. LO REVERSE CLUTCH PISTON              |
| 14. LO REVERSE SUPPORT AND ROLLER ASSEMBLY  | 29. CASE TO EXTENSION SEAL                |
| 15. CLUTCH SUPPORT RETAINER                 | 30. CASE EXTENSION                        |
|   | 31. REAR SEAL                             |

Figure 700-R4-20 Input - Reaction and Case Extension Parts

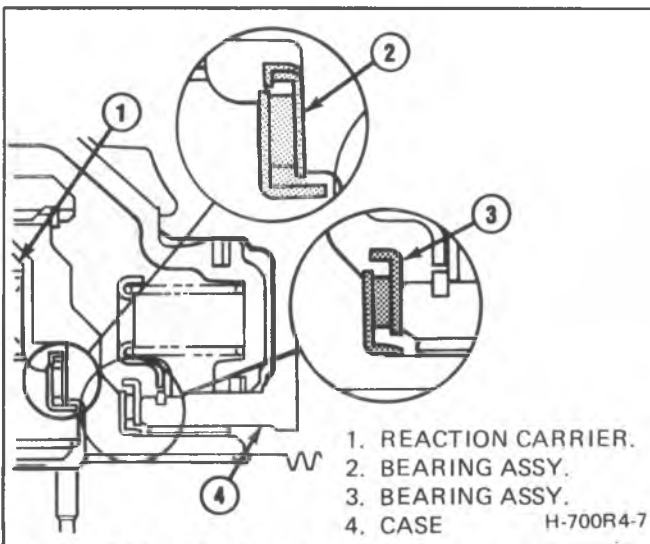

Figure 700-R4-21 Reaction Internal Gear and Carrier Bearing Locations

| LOW REV. CLUTCH |            |                    |                   |                    |
|-----------------|------------|--------------------|-------------------|--------------------|
| MODEL           | FLAT STEEL |                    | COMPOSITION FACED |                    |
|                 | NO.        | THICKNESS          | NO.               | THICKNESS          |
| TW<br>TC        | 4          | 1.77 mm<br>(.069") | 4                 | 2.25 mm<br>(.088") |
| ALL<br>OTHERS   | 5          | 1.77 mm<br>(.069") | 5                 | 2.25 mm<br>(.088") |

Figure 700-R4-24 Low Reverse Clutch Plate Chart

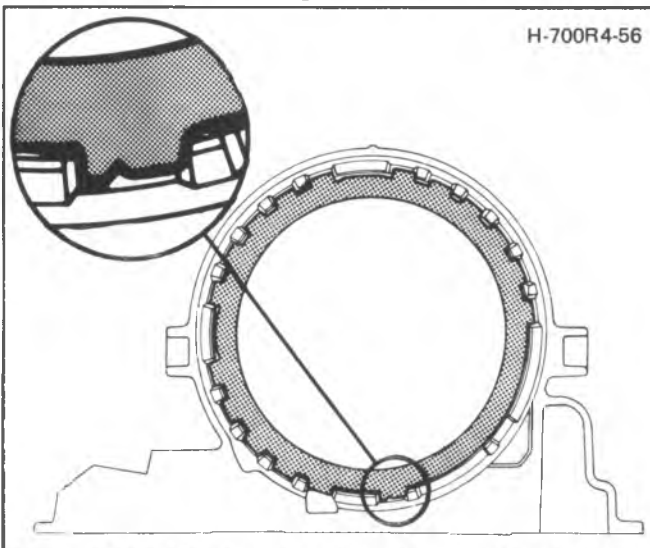

Figure 700-R4-22 Installing Low Reverse Clutch Plates

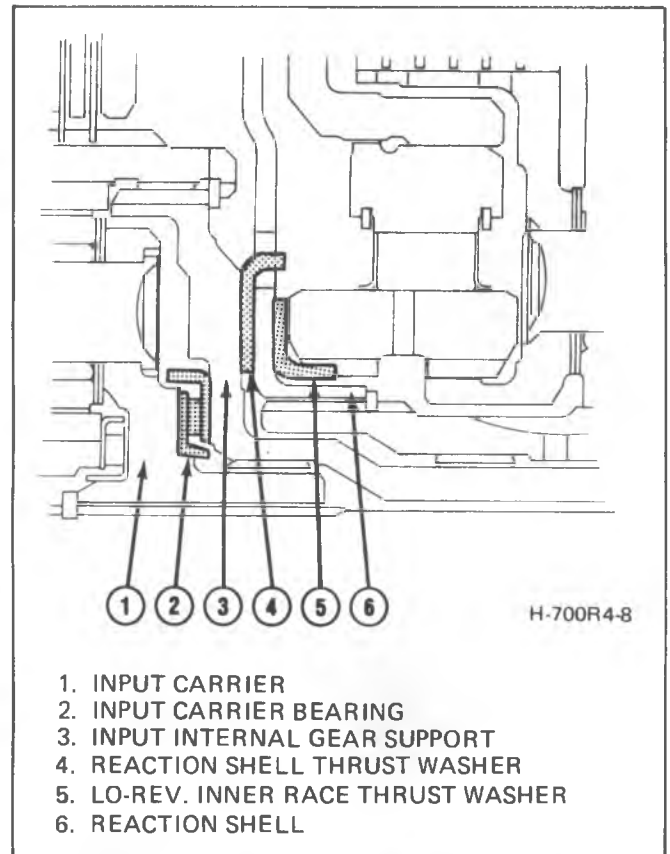

Figure 700-R4-25 Input Carrier and Reaction Shell Bearing and Thrust Washer Locations

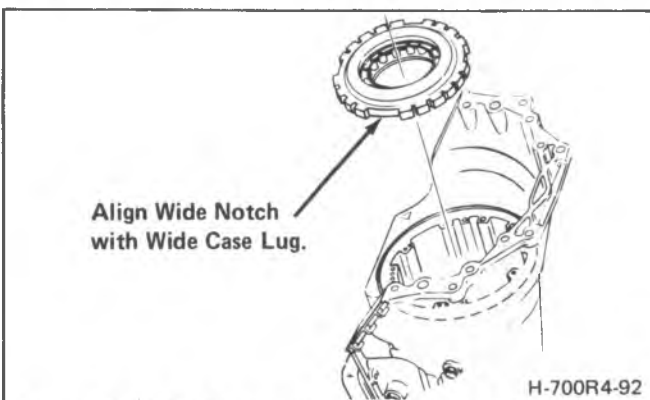

Figure 700-R4-23 Installing the Low Reverse Support and Roller Assembly

7. Remove the reverse input clutch piston and remove the inner and outer seals.

**Inspection**

1. Inspect the reverse input clutch backing plate for damage, distortion, flatness and burred edges on the clutch plate face.

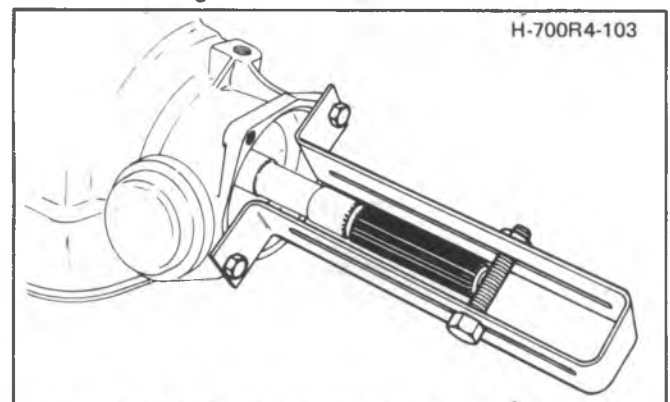

Figure 700-R4-26 Positioning Output Shaft with J-29837

2. Inspect the reverse plates (steel) for distortion, damage, heavy burned spots or pitting.

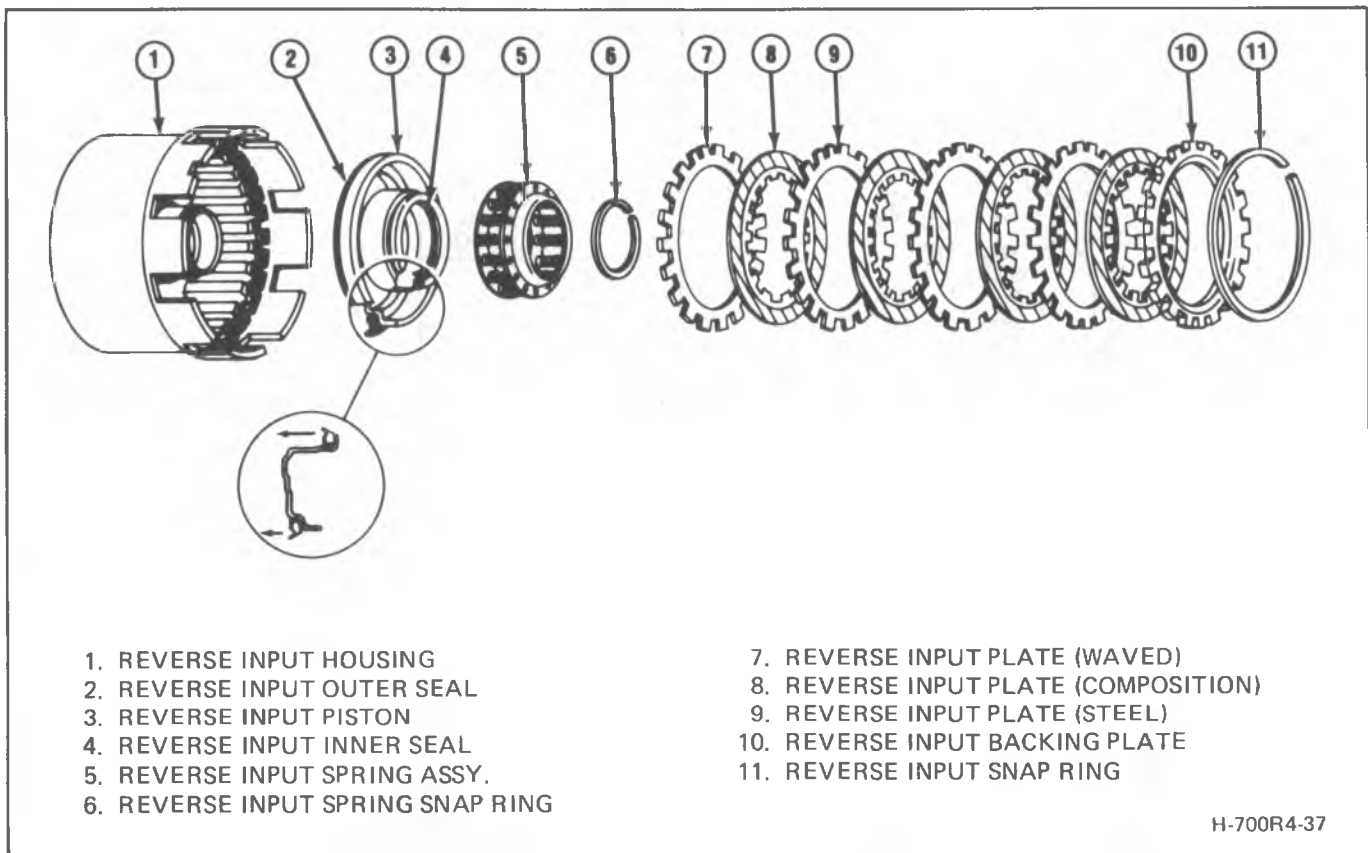

Figure 700-4R-27 Reverse Input Clutch Assembly

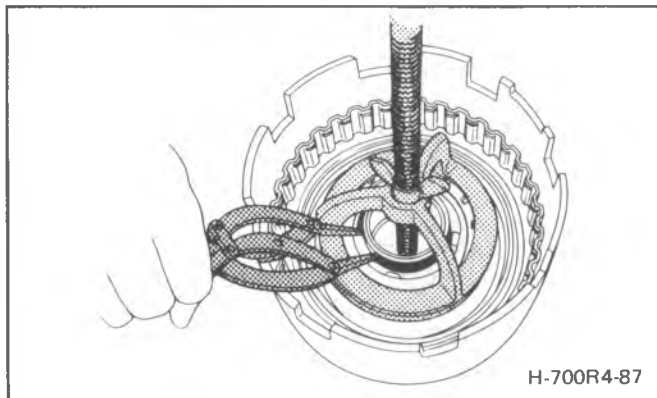

Figure 700-R4-28 Removing and Installing Reverse Input Snap Ring Using J-23327

3. Inspect the reverse input composition plates for burning, flaking and tooth damage. A dark color will not necessarily indicate a burned plate as some clutch plate materials will darken with age and heat.
4. Inspect the release spring retainer for distortion or damage.
5. Inspect the reverse input clutch piston and seals for damage, or distortion.
6. Inspect the reverse input housing and drum for cracks, surface finish on the hub, worn or damaged bushings, freeness and condition of the ball check. The ball must move freely with applied air pressure.

**Assembly**

(Fig. 29)

1. Lubricate and install the inner and outer seals on the reverse input clutch piston with the seal lips facing away from the hub.

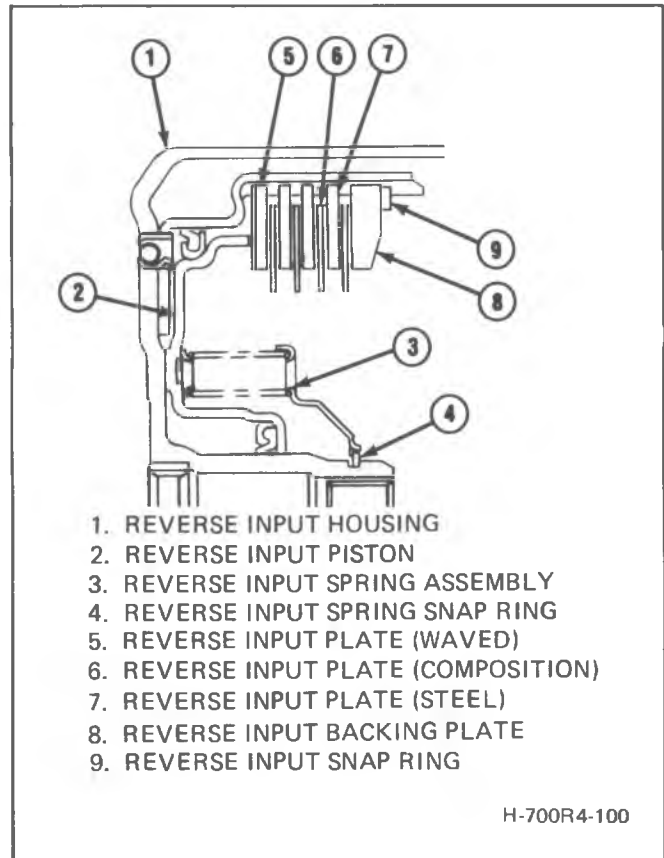

Figure 700-R4-29 Reverse Input Clutch Assembly

2. Install the reverse clutch piston into the reverse input housing with the hub upwards using an 8mm feeler gage to position the seal.



3. Install the reverse input clutch spring assembly with the large opening first.
4. Install tools J-23327 and J-25018-A on the spring retainer. Compress the spring retainer and install the retaining snap ring.
5. Remove all tools.
6. Install the (1) waved steel reverse plate. The waved plate is thinner and will show some high burnished spots. No indexing or alignment is required.
7. Install a composition plate, then install the balance of the plates, alternating composition faced and flat steel. (Fig. 30)

19. Remove the overrun clutch piston assembly.
20. Remove the inner and outer seals from the overrun clutch piston.
21. Remove the forward clutch piston assembly.
22. Remove the inner and outer seals from the forward clutch piston assembly.  
**Apply air pressure to the 3-4 feed hole in the turbine shaft - 3rd hole from the shaft end. If unable to remove parts strike housing on a soft surface squarely on the open end.**
23. Remove the forward clutch housing assembly.
24. Remove the 3-4 clutch spring assembly.
25. Remove the 3-4 apply ring and piston.
26. Remove the "O" Ring from the input housing assembly.
27. Inspect the (4) four teflon oil seal rings on the turbine shaft for damage or distortion.  
**Remove and Replace only if necessary.**

| REV. INPUT CLUTCH |            |                 |             |                 |             |                 |
|-------------------|------------|-----------------|-------------|-----------------|-------------|-----------------|
| H-700R4-74        |            |                 |             |                 |             |                 |
| MODEL             | FLAT STEEL |                 | COMP. FACED |                 | WAVED STEEL |                 |
|                   | NO.        | THICK-NESS      | NO.         | THICK-NESS      | NO.         | THICK-NESS      |
| TW TC             | 2          | 1.97 mm (.077") | 3           | 1.97 mm (.077") | 1           | 2.03 mm (.079") |
| ALL OTHERS        | 3          | 1.97 mm (.077") | 4           | 1.97 mm (.077") | 1           | 2.03 mm (.079") |

Figure 700-R4-30 Reverse Input Clutch Plate Chart

**The reverse clutch plates are the largest plates with equally spaced tangs.**

8. Install the reverse input backing plate with the chamfered side up.
9. Install the backing plate snap ring.

### INPUT CLUTCH ASSEMBLY

(Fig. 31)

#### Disassembly

1. Position the input clutch assembly on the bench with the turbine shaft located in a bench hole and resting on the turbine shaft housing.
2. Remove the snap ring retaining the 3-4 clutch backing plate.
3. Remove the 3-4 clutch backing plate.
4. Remove the 3-4 clutch plates (composition and steel).
5. Remove the 3-4 clutch apply plate.
6. Remove the 3-4 clutch retaining apply ring. (Fig. 32)
7. Remove the forward clutch backing plate snap ring.
8. Remove the forward clutch backing plate.
9. Remove the forward clutch cam assembly and outer race by pulling up.
10. Remove the input sun gear bearing (it can be located on the back side of the input inner race).
11. Remove the input housing to output shaft nylon seal.
12. Remove the forward clutch plates (steel and composition).
13. Remove the forward clutch apply plate and spacer if used.
14. Remove the overrun clutch plates (2 steel and 2 composition).
15. Install tools J-23456 and J-25018 and compress the overrun clutch spring retainer. (Fig. 33)
16. Remove the overrun clutch retaining snap ring.
17. Remove all tools.
18. Remove the overrun clutch spring assembly.

### FORWARD CLUTCH CAM ASSEMBLY

(Fig. 34)

#### Disassembly - Sprag Clutch

1. Remove the overrun clutch hub snap ring.
2. Remove the overrun clutch hub.
3. Remove the overrun clutch thrust washer.
4. Remove the forward clutch sprag cam. (inner race).
5. Remove the forward clutch sprag assembly from the forward clutch cam.

#### Inspection

1. FORWARD CLUTCH SPRAG ASSEMBLY.  
Inspect sprag assembly for wear or damage.
2. OVERRUN CLUTCH HUB  
Inspect the overrun clutch hub for spline damage, wear or distress, and that all lubrication passages are open.
3. FORWARD CLUTCH CAM  
Inspect the forward clutch cam for damage to splines and for wear.
4. FORWARD CLUTCH OUTER RACE  
Inspect for surface finish and damage.

#### Assembly - Sprag Clutch

1. Position the forward clutch cam with the retainer side down.
2. Install the sprag assembly with the two retainer rings over the cam hub. The lipped edge of the sprag must face the cam retainer. (Fig. 34)
3. Place the overrun hub thrust washer on the overrun hub and place this unit over the forward clutch cam.
4. Install the overrun clutch hub snap ring in the I.D. of the cam.
5. Install the assembled hub, cam and sprag inner race assembly into the forward clutch outer race by rotating clockwise. **When holding the outer race in your left hand, the overrun clutch hub must rotate freely, in a clockwise direction and must hold in a counterclockwise direction. (Fig. 35)**

### INPUT CLUTCH ASSEMBLY

#### Inspection

#### Input Housing Assembly

1. Inspect all splines for damage or wear.



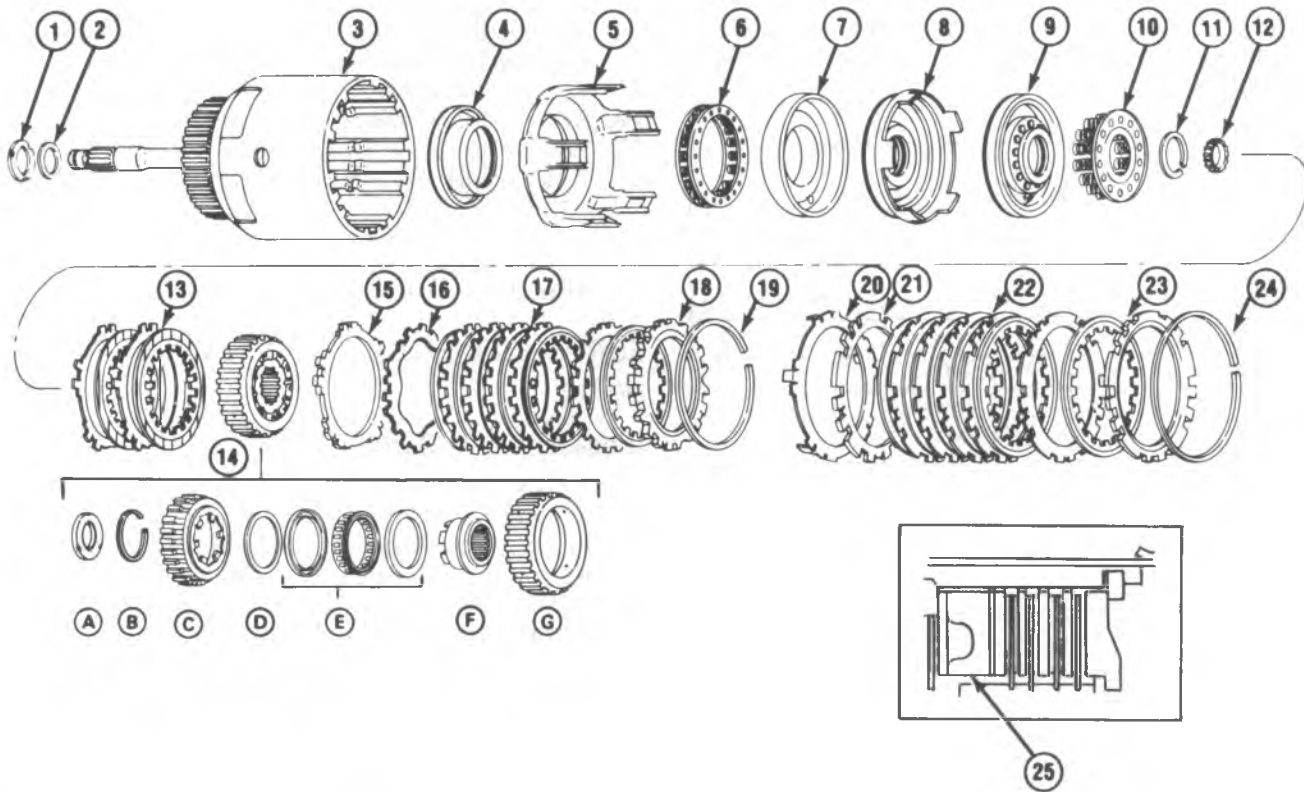

INPUT CLUTCH ASSY. (EXPLODED VIEW)

- |                                       |  |
|---------------------------------------|--|
| 1. STATOR SHAFT WASHER                | 15. FORWARD CLUTCH APPLY PLATE             |
| 2. SELECTIVE WASHER                   | 16. FORWARD CLUTCH WAVED PLATE             |
| 3. INPUT HOUSING ASSEMBLY             | 17. FORWARD CLUTCH PLATES                  |
| 4. 3-4 CLUTCH PISTON                  | 18. FORWARD CLUTCH BACKING PLATE           |
| 5. 3-4 CLUTCH APPLY RING              | 19. FORWARD CLUTCH BACKING PLATE SNAP RING |
| 6. 3-4 CLUTCH SPRING ASSEMBLY         | 20. 3-4 CLUTCH RETAINER RING               |
| 7. FORWARD CLUTCH HOUSING             | 21. 3-4 APPLY PLATE                        |
| 8. FORWARD CLUTCH PISTON              | 22. 3-4 CLUTCH PLATES                      |
| 9. OVERRUN CLUTCH PISTON              | 23. 3-4 CLUTCH BACKING PLATE               |
| 10. OVERRUN CLUTCH SPRING ASSEMBLY    | 24. 3-4 CLUTCH RETAINING RING              |
| 11. OVERRUN CLUTCH RETAINER SNAP RING | 25. FORWARD CLUTCH SPACER                  |
| 12. INPUT HOUSING SEAL                | 4 CLUTCH PACK                              |
| 13. OVERRUN CLUTCH PLATES             |  |
| 14. FORWARD CLUTCH CAM ASSEMBLY       |  |
| A. INPUT CLUTCH SUN GEAR BEARING      |  |
| B. OVERRUN CLUTCH HUB SNAP RING       |  |
| C. OVERRUN CLUTCH HUB                 |  |
| D. WEAR PLATE                         |  |
| E. FORWARD CLUTCH SPRAG ASSY.         |  |
| F. FORWARD CLUTCH SPRAG CAM           |  |
| G. FORWARD CLUTCH OUTER RACE          |  |

Figure 700-R4-31 Input Clutch Assembly

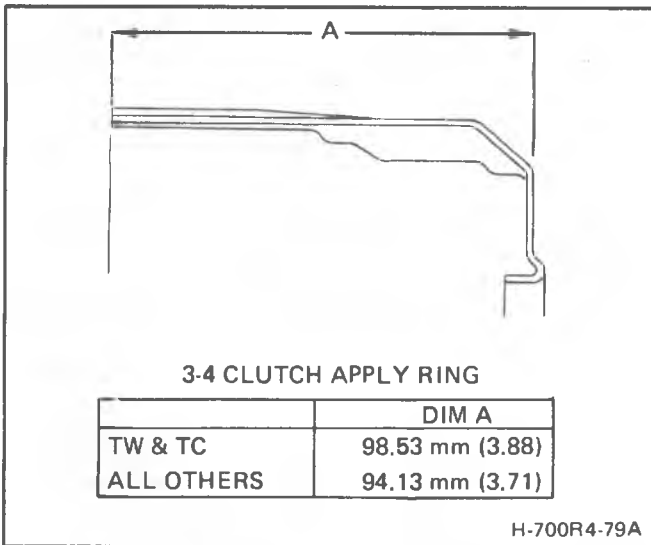

Figure 700-R4-32 3-4 Clutch Apply Ring Chart

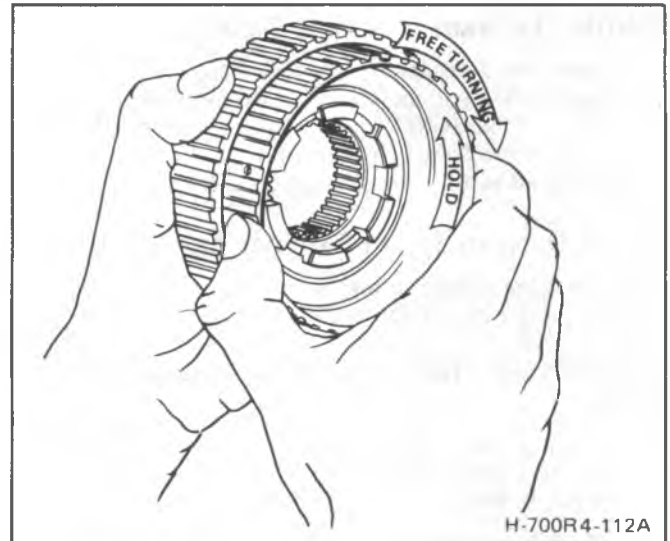

Figure 700-R4-35 Checking Sprag Clutch For Hold Position

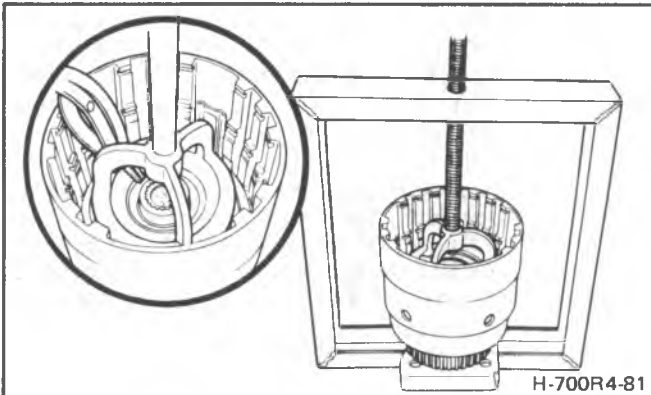

Figure 700-R4-33 Removing Overrun Clutch Snap Ring

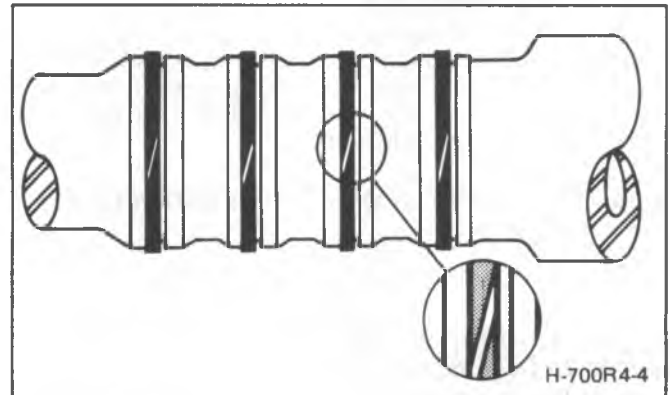

Figure 700-R4-36 Installing Turbine Shaft Oil Seal Rings

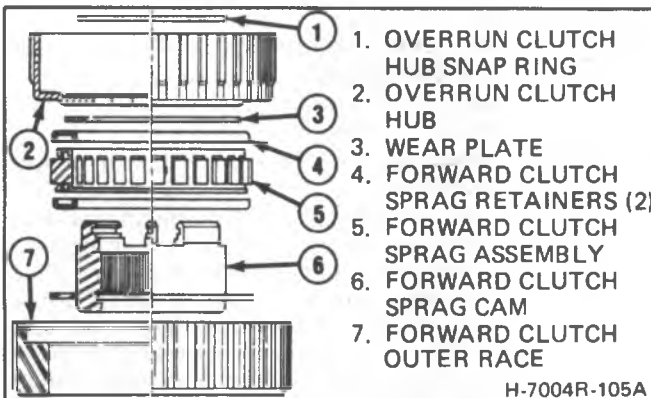

Figure 700-R4-34 Forward Clutch Cam Assembly

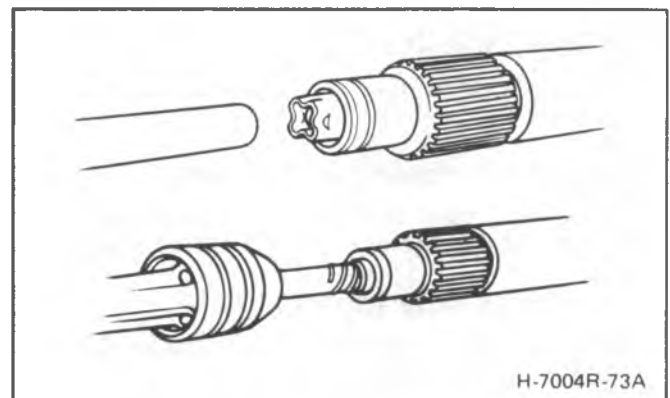

Figure 700-R4-37 Turbine Shaft Check Ball Replacement

2. Air check all clutch feed passages for obstructions.
3. Inspect the rear end of the turbine shaft for the presence of (3) three sealing balls.  
**One hole is an open feed hole and will not be sealed.**
4. Inspect the (4) four turbine shaft teflon seals for damage and correct installation. (Fig. 36)  
**Do not remove unless damaged or replacement is required.**
5. Inspect the converter check ball on the front end of the turbine shaft for restrictions and free operation. Ball must move with air pressure. If damaged, replace as follows: (Fig. 37)

- A. Straighten the tangs of the retainer and check valve assembly capsule and remove the check ball.
- B. Using a #4 easy out, remove the check valve retainer from the turbine shaft by turning and pulling straight out.
- C. Install the new check valve assembly, check valve seat first, into the turbine shaft.
- D. Using a 9.5mm (3/8) diameter metal rod and hammer drive retainer and check valve assembly until it is 3mm (1/8) below the top surface of the turbine shaft.
6. Inspect the 3-4 check ball in the input housing for free operation.

## Overrun - Forward - 3-4 Gear Pistons

Inspect the 3 pistons for the following:

1. Inspect all inner and outer seals for damage, cuts, softness or hardness if any are to be replaced, lubricate the new ones before installation.
2. Inspect all pistons for damage or porosity.

## 3-4 and Overrun Spring Retainer Assemblies

1. Inspect the release springs for damage, distortion, and the spring retainer for flatness or damage.

## Clutch Plates (Steel) - Overrun - Forward - 3rd & 4th

1. Inspect all steel clutch plates for damaged tang ends, high or burned spots, excessive wear, or distortion caused by heat.

## Clutch Plate Assemblies (Composition Faced) - Overrun - Forward - 3-4

1. Inspect the composition faced clutch plates for damaged tangs, burning, flaking or excessive wear (thickness). A dark color does not necessarily indicate burning. Some clutch plate material will darken with age and heat which is normal.

## Snap Rings - Overrun Clutch Hub Retaining and Overrun Clutch

1. Inspect for distortion damage and flatness.

## Backing Plates - 3-4 Clutch - Forward Clutch Spacer and 3-4 Apply Plate

1. Inspect for flatness, distortion and sharpness or burrs on inside edge.

## Apply Ring 3rd & 4th Clutch

1. Inspect the apply ring for distortion and damaged apply tangs.

## Forward Clutch Housing (Small Steel)

1. Inspect the ball check for proper operation and damage. Inspect the housing for distortion or damage.

## Needle Bearing Assy. (Stator Shaft)

1. Inspect needle bearings for excessive wear, flatness, damages or flat rollers.

## Oil Seal Ring - Turbine Shaft

1. Remove and inspect for damage and replace if required.

## INPUT CLUTCH ASSEMBLY

(Fig. 38)

### Assembly

1. If removed install the (4) four teflon oil seal rings on the turbine shaft. Assemble with a long edge to a long edge and the large "O" ring on the inside of the housing.
2. If removed, install the small "O" Ring on the end of the turbine shaft.
3. Position the input clutch housing over the bench hole with the turbine shaft in a hole pointing downwards.

4. Install the inner and outer seals on the 3-4 piston (smallest aluminum piston) with the lips facing away from the hub.
5. Install the 3-4 piston in the input housing, rotate and gently push downward making certain the piston is properly seated.
6. Install the inner and outer seals on the forward clutch piston (largest aluminum) with the lips facing away from the tangs.
7. Lubricate and install the forward clutch piston (largest remaining aluminum) into the forward clutch housing (large steel).
8. Install the 3-4 spring retainer into the 3-4 clutch apply ring.
9. Install the assembled forward clutch housing and piston on the spring retainer in the 3-4 apply ring. The notches of the forward clutch piston must be indexed with the long apply tangs of the 3-4 apply ring.
10. Install seal protector J-29883 on the input housing shaft. (Fig. 39)
11. Hold the 3-4 apply ring and assembled parts by the tangs and install into the input clutch housing and firmly seat the forward clutch piston. Remove tools. **Use care to insure the pistons do not separate.**
12. Install overrun clutch seal protector J-29882 on the input housing shaft and install the overrun clutch piston with the hub facing upward and remove tool. **When properly positioned the overrun piston will be approx. 3/16 inch below the snap ring groove on the input housing hub if not seated install J-23327 clutch spring compressor and gently tap until all parts are fully seated.**
13. Install the overrun clutch spring retainer on the overrun clutch piston locating the release springs on the piston tabs.
14. Position tools J-23456 and J-25018 overrun on the overrun spring assembly and compress the spring retainer. (Fig. 40) **Do not over compress springs as distortion to the retainer can occur.**
15. With the springs compressed, install the retaining snap ring and remove all tools.
16. Install the splined nylon output shaft seal, with the seal lip facing up. (Fig. 41)
17. On the forward clutch piston in the input housing, install the (4) four overrun clutch plates. Starting with a steel plate and positioning so that the long recessed slot is indexed with a wide notch in the housing, install the remaining clutch plates alternating steel and composition. The overrun plates will be the smallest of the (3) three clutch plate sets in the input clutch assembly. (Figs. 42 & 44)
18. Install the input sun gear bearing assembly on the input clutch hub on top of the nylon seal positioning the outside "L" race in the downward position. (Fig. 43) **Make certain the bearing is properly centered.**
19. With a screwdriver, align and center the inside drive tangs of the (2) two overrun clutch plates (composition).
20. Install the assembled forward clutch cam assembly and outer race clutch hub indexing the overrun clutch plates.
21. Install the forward clutch spacer (thick steel) into the input clutch housing, indexing the lug on the spacer with the large slot in the input housing. **A five clutch plate forward clutch, will use a single thick apply plate. A four clutch forward clutch, will use a thick spacer and a thin apply**

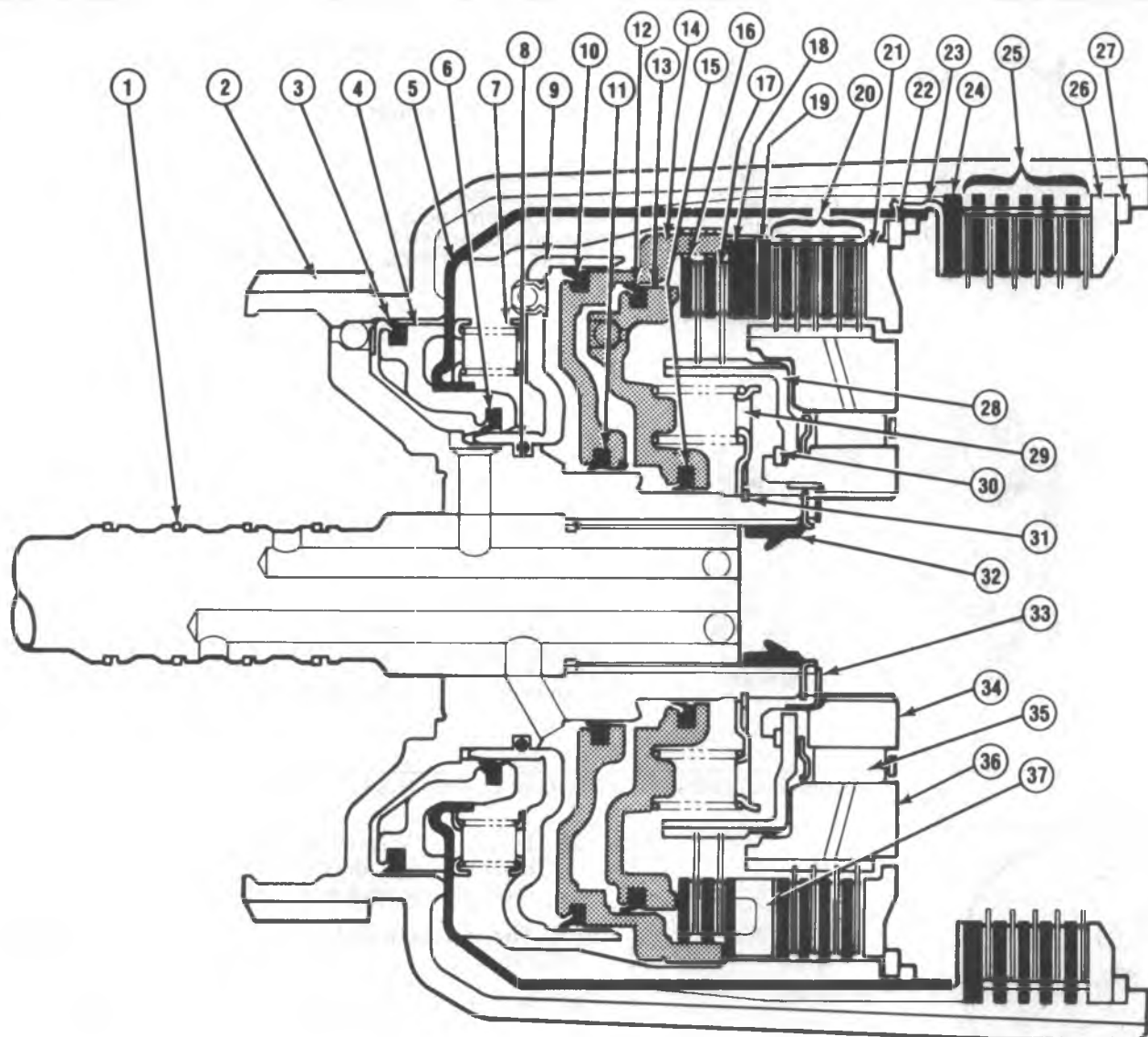

- |                                  |                                     |
|----------------------------------|-------------------------------------|
| 1. TEFLON TURBINE SHAFT SEALS    | 20. FORWARD CLUTCH PLATES           |
| 2. INPUT HOUSING ASSEMBLY        | 21. FORWARD CLUTCH BACKING PLATE    |
| 3. 3-4 CLUTCH OUTER SEAL         | 22. FORWARD CLUTCH SNAP RING        |
| 4. 3-4 CLUTCH PISTON             | 23. 3-4 CLUTCH RETAINING RING       |
| 5. 3-4 CLUTCH APPLY RING         | 24. 3-4 APPLY PLATE                 |
| 6. 3-4 CLUTCH INNER SEAL         | 25. 3-4 CLUTCH PLATES               |
| 7. 3-4 CLUTCH SPRING ASSEMBLY    | 26. 3-4 CLUTCH BACKING PLATE        |
| 8. INPUT FORWARD CLUTCH "O" RING | 27. 3-4 CLUTCH RETAINING RING       |
| 9. FORWARD CLUTCH HOUSING        | 28. OVERRUN CLUTCH HUB              |
| 10. FORWARD CLUTCH OUTER SEAL    | 29. OVERRUN CLUTCH SPRING ASSY.     |
| 11. FORWARD CLUTCH INNER SEAL    | 30. OVERRUN CLUTCH HUB SNAP RING    |
| 12. OVERRUN CLUTCH OUTER SEAL    | 31. OVERRUN CLUTCH SPRING SNAP RING |
| 13. OVERRUN CLUTCH PISTON        | 32. INPUT HOUSING SEAL              |
| 14. FORWARD CLUTCH PISTON        | 33. INPUT CLUTCH SUN GEAR BEARING   |
| 15. OVERRUN CLUTCH INNER SEAL    | 34. FORWARD CLUTCH SPRAG CAM        |
| 16. FORWARD CLUTCH PISTON        | 35. FORWARD CLUTCH SPRAG ASSY       |
| 17. OVERRUN CLUTCH PLATES        | 36. FORWARD CLUTCH OUTER RACE       |
| 18. FORWARD CLUTCH APPLY PLATE   | 37. FORWARD CLUTCH SPACER           |
| 19. FORWARD CLUTCH WAVED PLATE   | (USED WITH FOUR CLUTCH PLATES ONLY) |

H-7004R-99A

Figure 700-R4-38 Input Clutch Assembly Cross Section

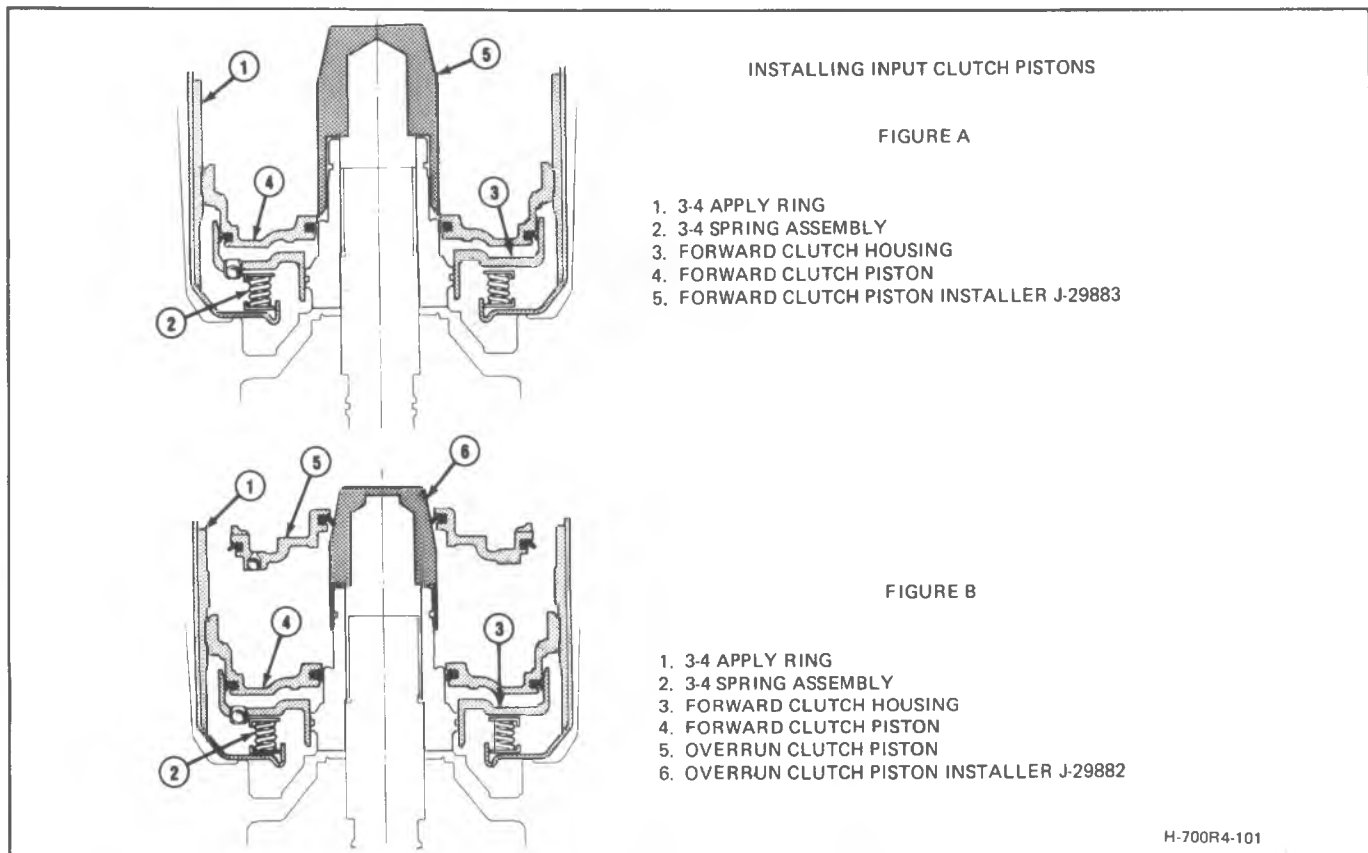

Figure 700-R4-39 Installing Input Clutch Pistons

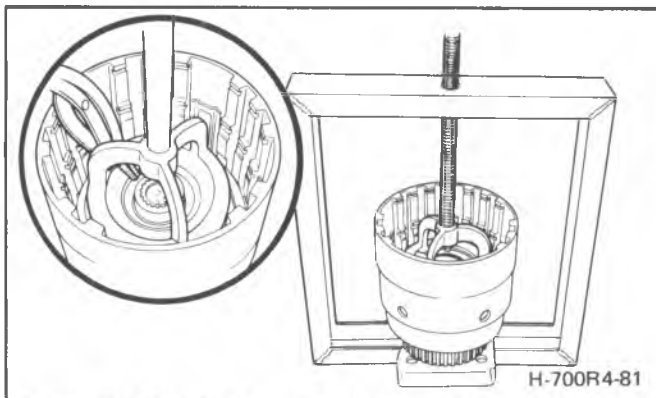

Figure 700-R4-40 Installing Overrun Clutch Snap Ring

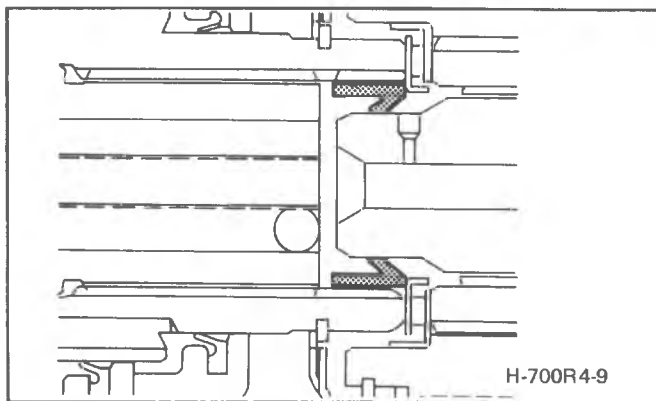

Figure 700-R4-41 Input Housing to Output Shaft Seal Location

plate, and must be assembled with the thin apply plate first and the spacer with the holes facing the thin apply plate.

22. Install the "Waved" steel forward clutch plate into the input housing, indexing the wide slot with (2) two small ears with the wide notch in the housing.

**The waved steel plate will show high burnish marks.**

23. Install a forward clutch plate assembly (composition) on the forward clutch hub. In the same manner, install the remaining forward clutch plates alternating composition and steel. The last plate installed will be composition. (Fig. 45)

24. Install the forward clutch backing plate into the input housing, with the chamfered side up.

25. Install the forward clutch backing plate snap ring into the input clutch housing (smaller ring with the larger gap).

26. Install the 3-4 gear ring retaining plate (flat plate with legs) into the clutch housing indexing each apply lug with the ends of the 3-4 gear apply ring.

27. Install the 3-4 gear apply plate (thick steel) into the input housing indexing the long wide gear of the plate with the wide slot in the housing.

28. Install a 3-4 plate assembly (composition) then install the remaining plates alternating steel and composition indexing the long wide ear of the plate with the wide slot in the housing. The last plate installed will be composition. (Figs. 46 & 47)

29. Install the 3-4 gear backing plate with the chamfered side up.

30. Install the 3-4 gear retaining ring into the input housing assembly.

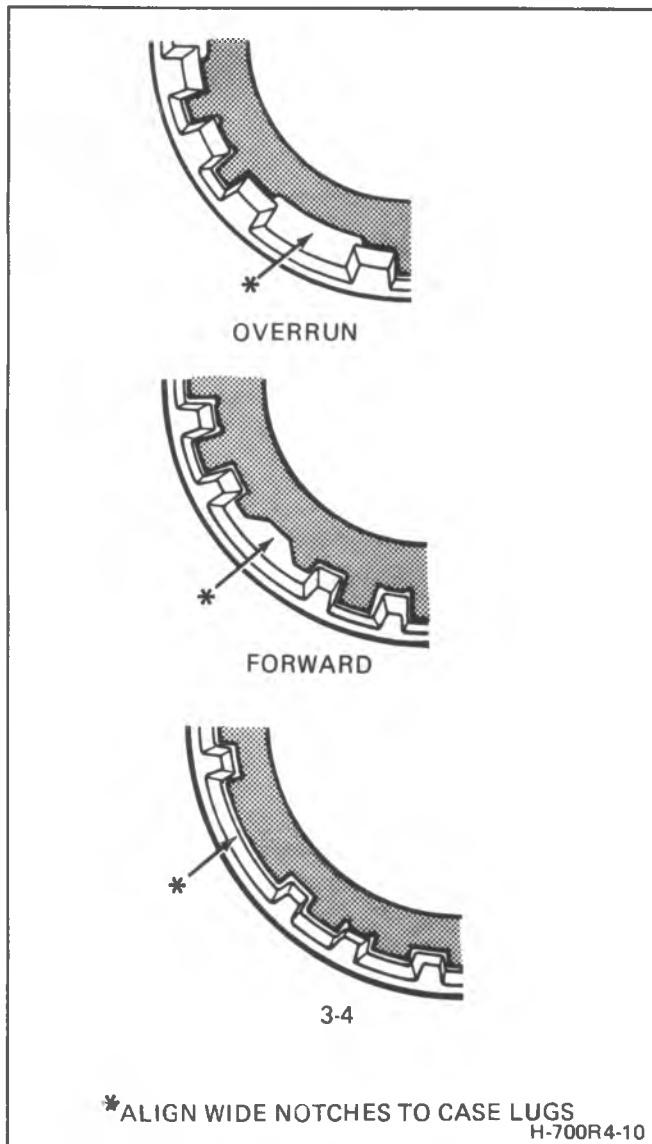

Figure 700-R4-42 Installing Input Clutch Plates

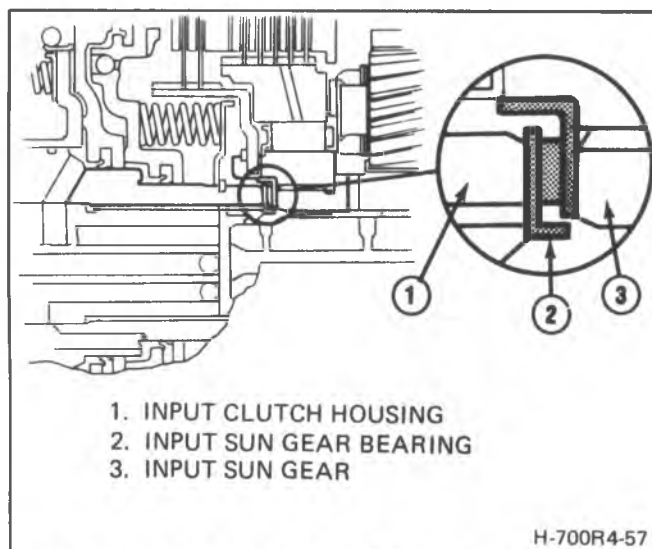

Figure 700-R4-43 Input Sun Gear Bearing Location

| H-700R4-43<br>OVERRUN CLUTCH |            |                 |             |                 |
|------------------------------|------------|-----------------|-------------|-----------------|
| MODEL                        | FLAT STEEL |                 | COMP. FACED |                 |
|                              | NO.        | THICKNESS       | NO.         | THICKNESS       |
| ALL MODELS                   | 2          | 2.34 mm (.091") | 2           | 2.03 mm (.079") |

Figure 700-R4-44 Overrun Clutch Plate Chart

### 3-4 Clutch Piston Travel Check

(Fig. 47)

Using feeler gages, measure the end clearance between the backing plate and the first composition plate. If the end clearance is not within specifications, select the proper backing plate from the chart.

### Clutch Air Check

Air check all clutches by applying air pressure at the feed holes in the turbine shaft. (Fig. 48)

## REVERSE INPUT AND INPUT CLUTCH

### Installation

1. Install the selective washer on the turbine housing.
2. Install pump hub bearing on the selective washer. With the black finish side up (Fig. 49)
3. Position the reverse input assembly on the bench hole with the clutch plates facing upward. Align and center the clutch plates with a screwdriver and install the input clutch assembly with turbine shaft downward indexing the reverse clutch plates with the hub of the input housing.

**Make certain all clutch plates are fully engaged.**

## THE REVERSE AND INPUT CLUTCHES

### Assembly

1. Install the reverse and input clutch assemblies as a complete unit into the transmission case indexing the 3-4 clutch plates of the input assembly with the input internal gear. The complete assembly will be properly seated when the reverse housing is located just below the pump face of the case.

**Make certain all clutch plates are fully engaged.**

## INTERNAL PARTS

### Installation

1. Install the 2-4 band into the case indexing the band anchor pin end with the case pin hole. (Fig. 50)
2. Install the band anchor pin in the case, indexing with the 2-4 band end.  
2-4 Servo Assembly.

### Disassembly (Fig. 51)

1. Remove the 4th apply piston and housing from the 2nd apply piston assembly.

700-R4-28 AUTOMATIC TRANSMISSION

| FORWARD CLUTCH |            |                    |             |                    |             |                    |        |                    |             | H-700R4-45         |
|----------------|------------|--------------------|-------------|--------------------|-------------|--------------------|--------|--------------------|-------------|--------------------|
| MODEL          | FLAT STEEL |                    | COMP. FACED |                    | APPLY PLATE |                    | SPACER |                    | WAVED STEEL |                    |
|                | NO.        | THICK-NESS         | NO.         | THICK-NESS         | NO.         | THICK-NESS         | NO.    | THICK-NESS         | NO.         | THICK-NESS         |
| TW<br>TC       | 3          | 1.97 mm<br>(.077") | 4           | 2.03 mm<br>(.079") | 1           | 6.44 mm<br>(.251") | 1      | 8.45 mm<br>(.330") | 1           | 2.03 mm<br>(.079") |
| ALL<br>OTHERS  | 4          | 1.97 mm<br>(.077") | 5           | 2.03 mm<br>(.079") | 1           | 6.44 mm<br>(.251") | NONE   |                    | 1           | 2.03 mm<br>(.079") |

Figure 700-R4-45 Forward Clutch Plate Chart

| 3-4 CLUTCH    |            |                    |             |                    |             |                    |               |            |            | H-700R4-44      |
|---------------|------------|--------------------|-------------|--------------------|-------------|--------------------|---------------|------------|------------|-----------------|
| MODEL         | FLAT STEEL |                    | COMP. FACED |                    | APPLY PLATE |                    | BACKING PLATE |            | APPLY RING |                 |
|               | NO.        | THICK-NESS         | NO.         | THICK-NESS         | NO.         | THICK-NESS         | NO.           | THICK-NESS | NO.        | LENGTH          |
| TW<br>TC      | 4          | 1.97 mm<br>(.077") | 5           | 2.03 mm<br>(.079") | 1           | 3.30 mm<br>(.128") | 1             | SELECTIVE  | 1          | 98.53<br>(3.88) |
| ALL<br>OTHERS | 5          | 1.97 mm<br>(.077") | 6           | 2.03 mm<br>(.079") | 1           | 3.30 mm<br>(.128") | 1             | SELECTIVE  | 1          | 94.13<br>(3.71) |

Figure 700-R4-46 3-4 Clutch Plate Chart

- Remove the servo apply pin spring from the servo apply pin.
- Disassemble the 2nd servo apply piston assembly using J-22269-01 and separate the 2nd apply piston, spring and retainer. (Fig. 52)
- Remove the retaining 'E' ring, washer and spring from the servo apply pin, and remove the pin.
- Remove all oil seal rings.

Inspection

- Inspect all pistons for porosity or damage.
- Inspect all springs and oil seal rings for distortion or damage.

Assembly

Assemble all parts in the reverse order.

**Assemble all flat edged seals with the flat edge to flat edge and coat with petrolatum.**

(Figs. 51 and 52)

- Install the complete 2-4 servo assembly into the case indexing the servo apply pin on the 2-4 band end and check for proper engagement.

**Recheck for the correct apply pin length if any of the servo parts, the 2-4 band or the input housing have been replaced.**

- Install the servo cover and "O" Ring into the case.
- Install the servo compressing tool J-29714 and compress the servo cover. (Fig. 53)
- Install the servo retaining ring, indexing the ring ends with the slot in the case.

| 3-4 BACKING PLATE SELECTION |                                   |                     |      | H-700R4-55C |
|-----------------------------|-----------------------------------|---------------------|------|-------------|
| MODEL                       | BACKING PLATE TRAVEL              | BACKING PLATE       |      |             |
|                             |                                   | DIM                 | I.D. |             |
| T.W.<br>T.C.                | 1.39 - 2.78 mm<br>(.055" - .109") | 7.125 mm<br>(.278") | 1    |             |
|                             |                                   | 6.125 mm<br>(.239") | 2    |             |
|                             |                                   | 5.125 mm<br>(.200") | 3    |             |
|                             |                                   | 4.125 mm<br>(.161") | 4    |             |
| ALL<br>OTHERS               | 1.25 - 2.87 mm<br>(.049" - .113") | 7.125 mm<br>(.278") | 1    |             |
|                             |                                   | 6.125 mm<br>(.239") | 2    |             |
|                             |                                   | 5.125 mm<br>(.200") | 3    |             |

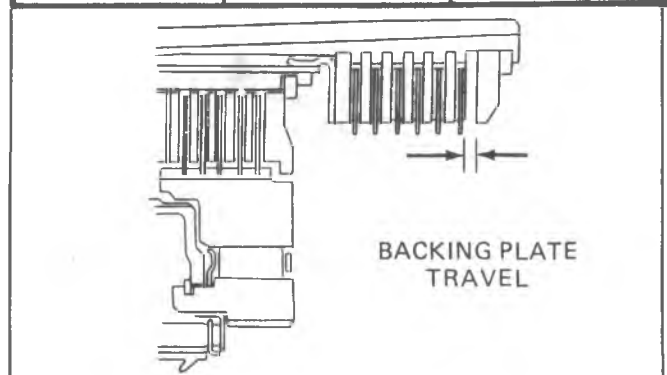

Figure 700-R4-47 3-4 Backing Plate Selection Chart



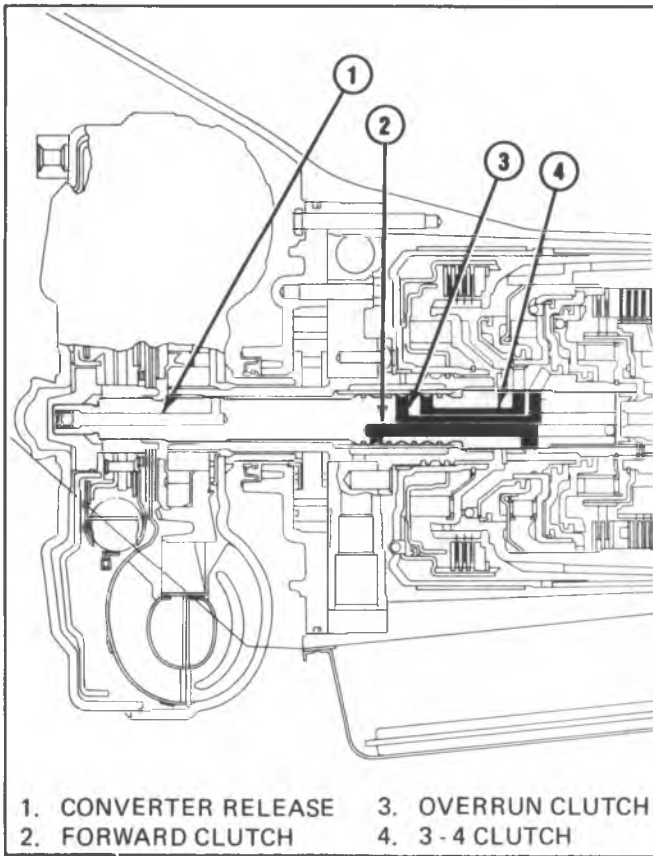

Figure 700-R4-48 Turbine Shaft Oil Passage I.D.

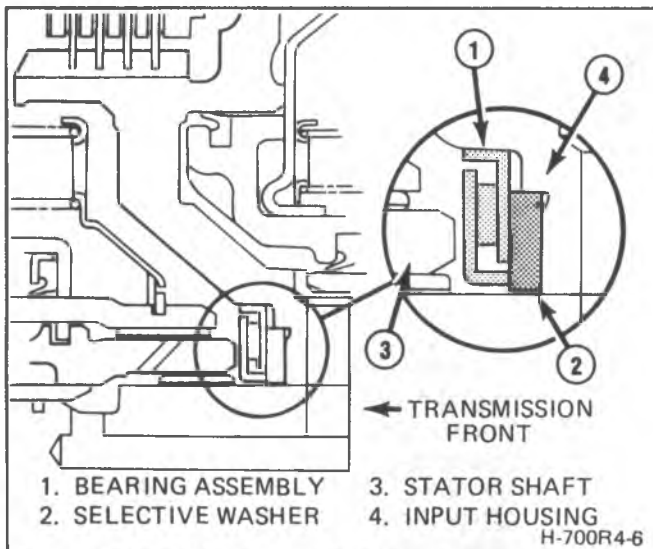

Figure 700-R4-49 Stator Shaft Bearing and Selective Washer Locations

## OIL PUMP ASSEMBLY

### Disassembly

1. Remove the drum to pump washer from the pump assembly.
2. Remove the pump cover to case gasket from the pump cover.
3. Remove the pump to case oil seal ring from the pump assembly.

**Do not remove the (2) two teflon oil seal rings from the pump hub unless they require replacement.**

4. Remove the pump cover from the pump body.

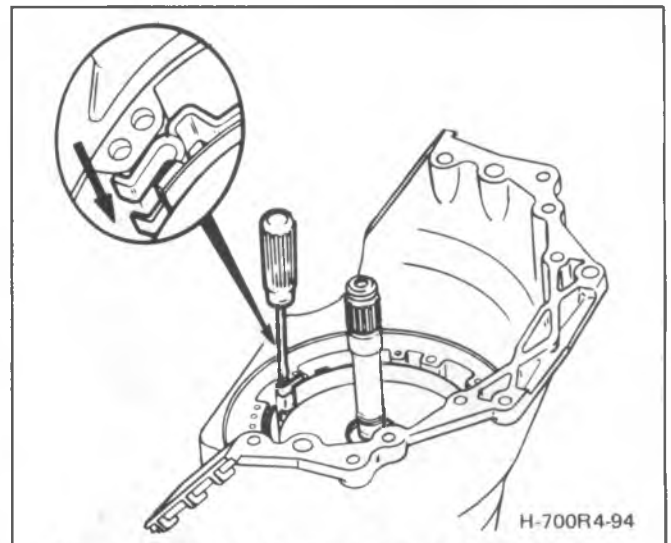

Figure 700-R4-50 Installing The 2-4 Band Assy.

## Pump Body

(Fig. 55)

### Disassembly

1. Remove the pump slide spring by compressing the spring with the needle nose pliers and pulling straight out or with a large bent end screwdriver.  
**CAUTION: Spring is under very high pressure: Place covering over spring to prevent possible injury.**
2. From the pump pocket, remove the following:
  - a. Pump Guide Rings
  - b. Pump Vanes
  - c. Pump Rotor
  - d. Rotor Guide
3. Remove the slide from the pump pocket.
4. Remove the slide seal and support seal from the pump body pocket or slide.
5. Remove the pivot slide pin and spring from the pocket.
6. Remove the slide seal ring and slide backup seal from the slide pump pocket.

## Front Pump Cover

(Fig. 54)

### Disassembly

1. Converter Clutch Apply Valve
  - a. Using a small screwdriver, push on the retainer to compress the converter clutch apply valve spring and remove the snap ring.
  - b. Slowly release the valve spring tension and remove the retainer and converter clutch apply valve and spring.
2. Pressure Relief Ball
  - a. Remove the pressure relief spring retaining rivet with a small punch.  
**Rivet is under very strong spring pressure.**
  - b. Remove the pressure relief spring and ball. If the ball is not free remove by applying air pressure to the oil passage located in the pump cover.
3. Oil Pump Screen
  - a. Using small pliers remove the oil screen and "O" Ring from the pump cover.
4. Pressure Regulator Assembly



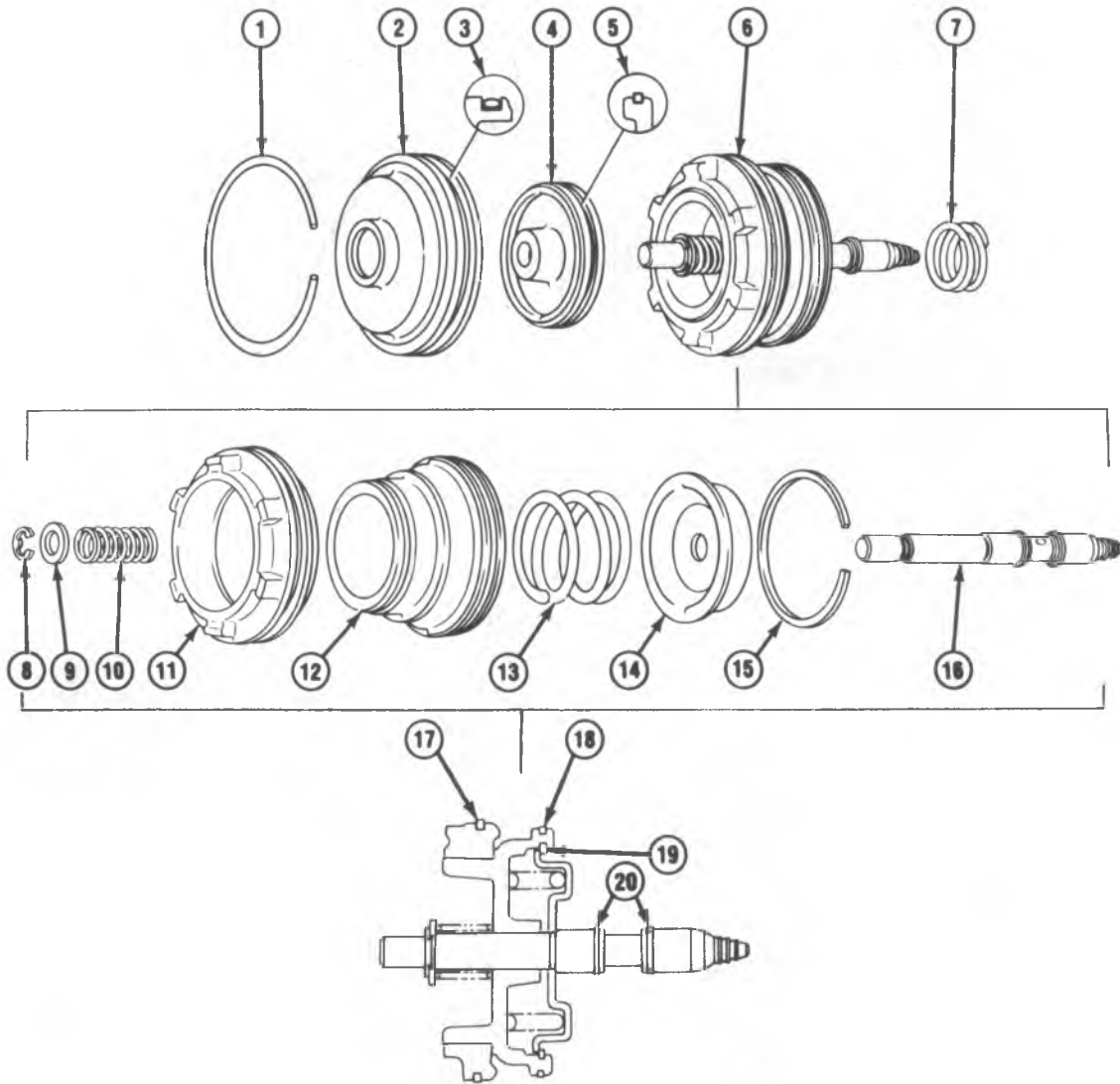

- |  |   |
|--|---|
| <ul style="list-style-type: none"> <li>1. SERVO COVER RETAINING RING.</li> <li>2. 2-4 SERVO COVER.</li> <li>3. 2-4 SERVO COVER SEAL.</li> <li>4. 4TH APPLY PISTON.</li> <li>5. 4TH APPLY PISTON RING.</li> <li>6. 2ND SERVO ASSEMBLY.</li> <li>7. SERVO RETURN SPRING.</li> <li>8. RETAINING RING.</li> <li>9. SERVO APPLY PIN WASHER.</li> <li>10. SERVO APPLY PIN SPRING.</li> </ul> | <ul style="list-style-type: none"> <li>11. 4TH APPLY PISTON ASSEMBLY.</li> <li>12. 2ND APPLY PISTON.</li> <li>13. SERVO CUSHION SPRING.</li> <li>14. SERVO SPRING RETAINER.</li> <li>15. 2ND APPLY PISTON OUTER SEAL.</li> <li>16. SERVO APPLY PIN.</li> <li>17. SERVO HOUSING SEAL.</li> <li>18. 2ND APPLY PISTON OUTER SEAL.</li> <li>19. RETAINING RING.</li> <li>20. SERVO APPLY PIN SEAL.</li> </ul> |
|--|---|

Figure 700-R4-51 2-4 Servo Assembly

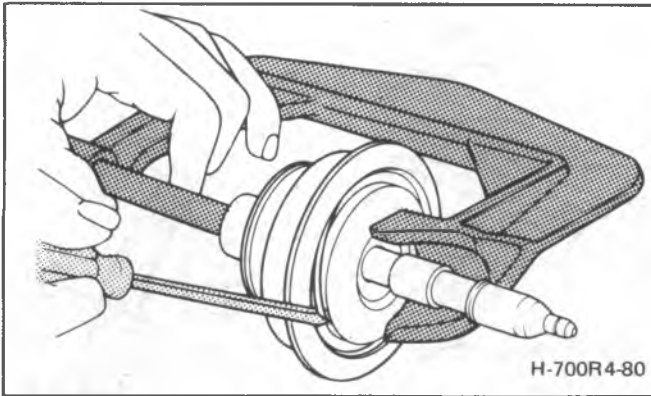

Figure 700-R4-52 Removing or Installing the 2nd Servo Snap Ring with J-22269-01

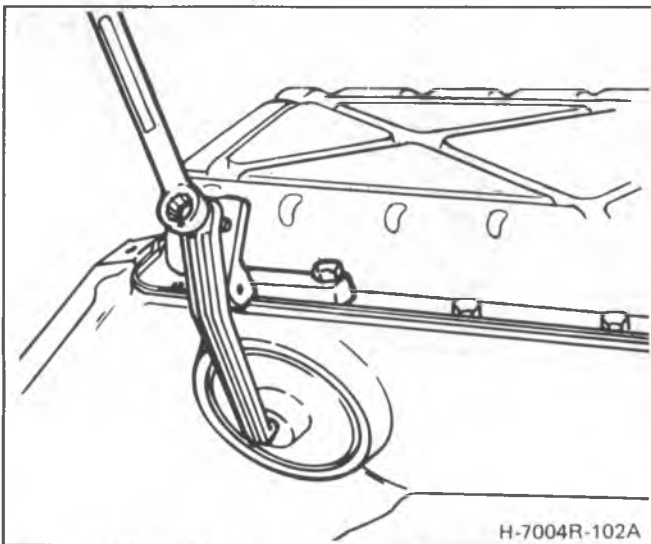

Figure 700-R4-53 Installing Servo Cover with J-29714

- a. Locate the pump with the stator shaft down through a hole in the bench and secure with a holding bolt.
- b. With a small screwdriver compress the T.V. boost valve bushing and remove the snap ring.
- c. Remove the T.V. boost valve bushing and valve with a small magnet.
- d. In the same manner remove the reverse boost valve bushing and valve and the pressure regulator valve and spring.

#### Inspection

1. Pressure Regulator Assembly
  - a. Inspect all valves, springs and bushings for chips, burrs, distortion and freeness of bore fits.
2. Converter Clutch Apply Valve Assembly
  - a. Inspect the converter clutch apply valve and spring for distortion or damage, and freeness in the pump bore.
3. Pressure Relief Assembly
  - a. Inspect the pressure relief ball and spring for damage, or distortion.
4. Pump Screen
  - a. Inspect the oil pump cover screen and "O" Ring for damage or distortion. Clean or replace as required.
5. Pump Cover and Body
  - a. Clean the cover and body and inspect all bores for foreign material.

- b. Inspect the mating sides of the cover and body for scoring, flatness, porosity or voids between channels.
- c. Inspect all channels for dirt, interconnected passages or damage.
- d. Inspect the pump rotor and slide for scoring, cracks or damage.
- e. Inspect all springs for distortion or damage.
- f. Inspect the rotor guide and pump vane rings for excessive wear or damage.
- g. Inspect all seals for damage.
- h. Inspect the front seal for damage or excess wear and the seal retaining spring for proper location and damage.

#### Pump Body

(Figs. 56 and 57)

##### Assembly

1. Install the pump slide "O" Ring and flat steel ring into the groove on the back side of the slide. Retain the petrolatum.
2. Install the small pivot pin and spring into the small hole located in the pump pocket.
3. Install the pump slide into the pump, positioning so that the notch in the slide is indexed with the pivot pin hole and the flat oil seal ring facing downward into the pocket.
4. Install the pump slide seal and support into the slide adjacent to the rotor.  
**The pump slide seal (composition) must be positioned against the other diameter of the pump pocket.**
5. Install a vane ring into the pump pocket centering on the stator hole.
6. Install the composition rotor guide into the deep pocket of the rotor indexing the notches, and retain with petrolatum.
7. Install the rotor and guide into the pump pocket with the guide positioned downward.
8. Install the vanes into the rotor positioning so they are flush with the rotor and with the full wear pattern against the slide.
9. Install the vane guide ring into the rotor.

**NOTICE:** All components must be flush with pump body face.

10. Compress the pump slide spring and install into pump pocket.

#### Oil Pump Cover

##### Assembly

1. Oil Pump Screen
  - a. Assemble the "O" Ring on the oil pump screen and install in the bore of the pump with the seal end last.
2. Pressure Relief Ball
  - a. Install the pressure relief ball and spring, ball first.
  - b. Install the retaining rivot.
3. Converter Clutch Apply Valve
  - a. Install the converter clutch apply valve spring on the long end of the converter clutch apply valve and retain with petrolatum. (Fig. 58)
  - b. Install the converter clutch apply valve and spring into the bore of the pump.

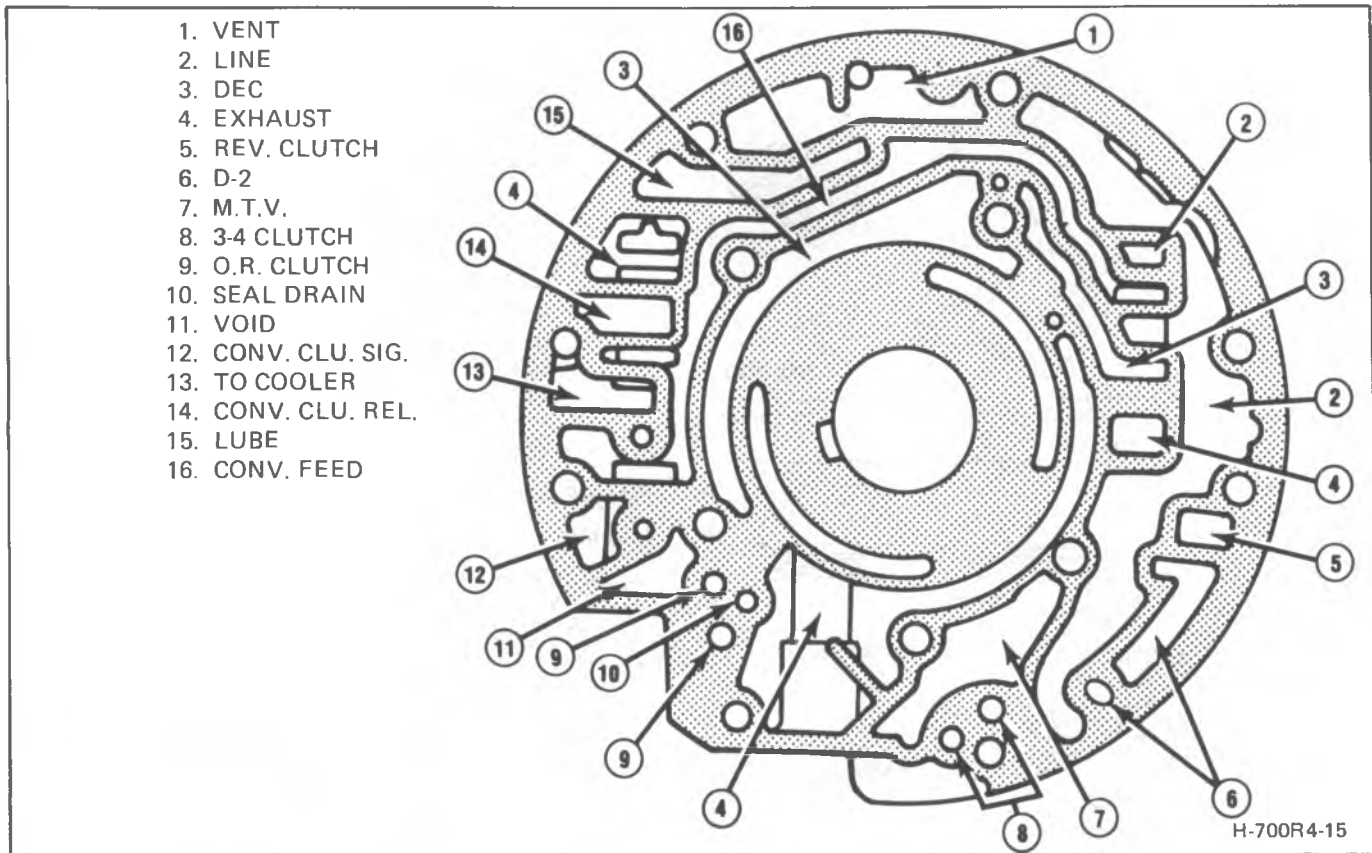

Figure 700-R4-54 Pump Cover Passage I.D.

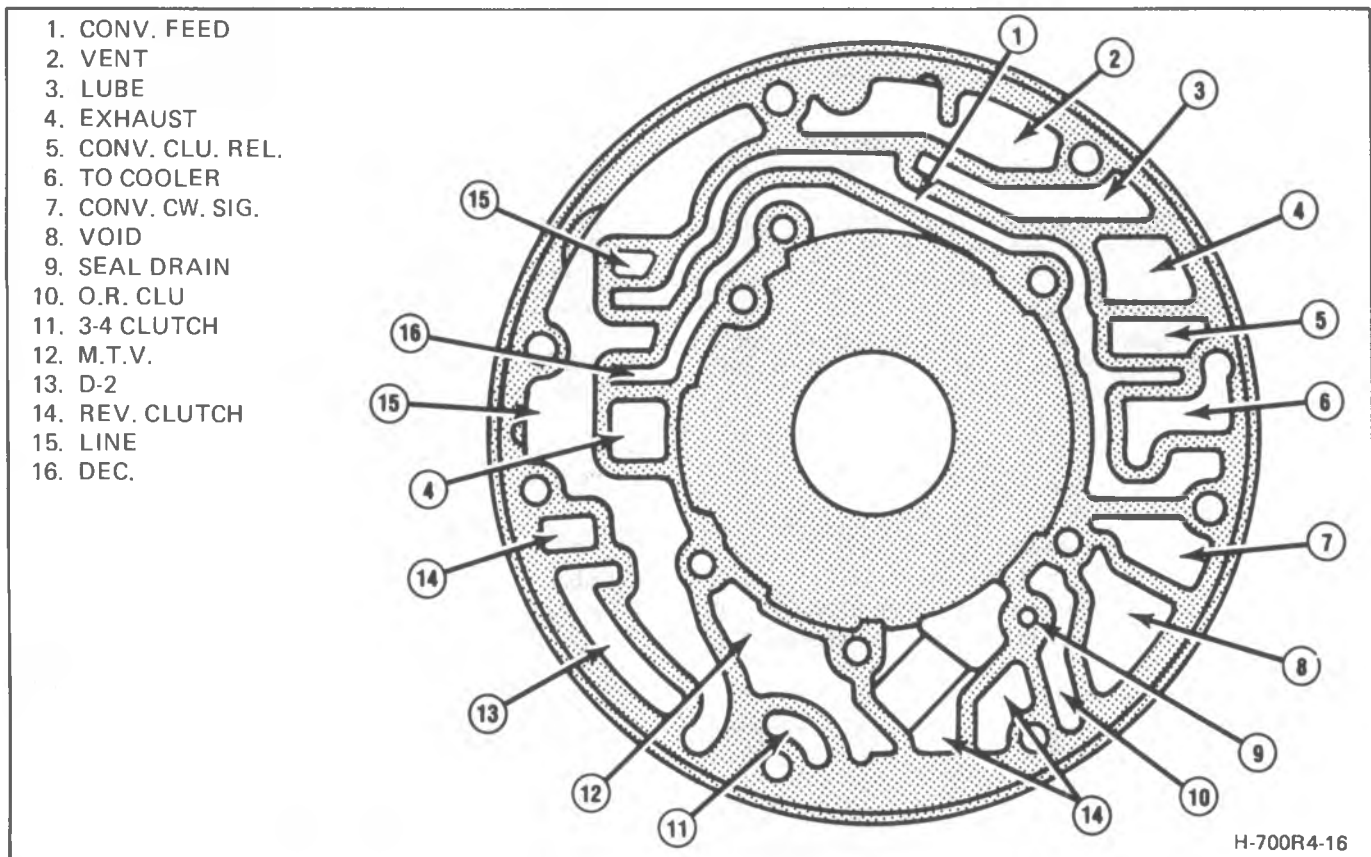

Figure 700-R4-55 Pump Body Passage I.D.

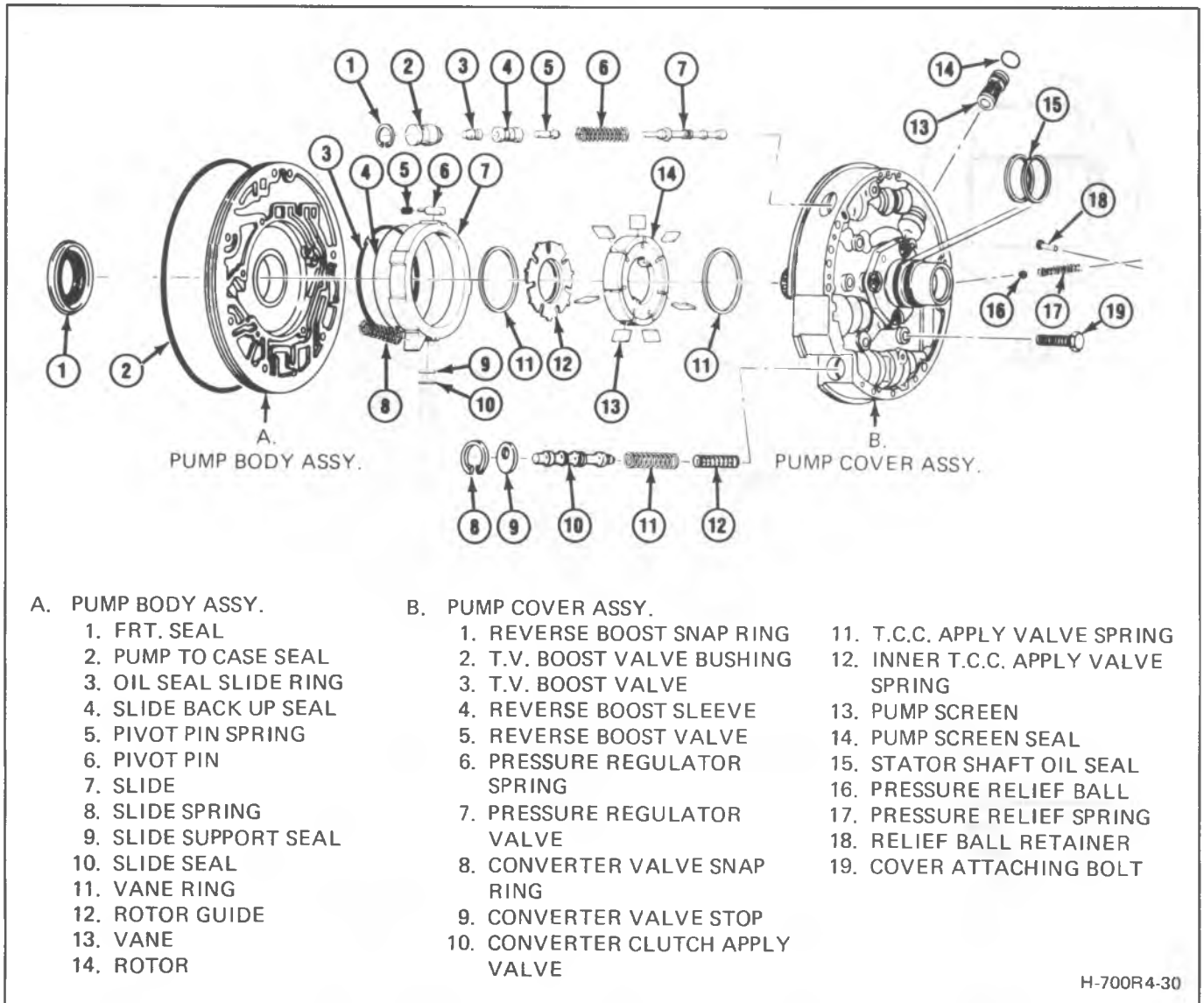

Figure 700-R4-56 Pump Assembly

H-700R4-30

- c. Install the retainer and snap ring.
- 4. Pressure Regulator Assembly
  - a. Position the pump cover so that the pressure regulator bore is located in the vertical position.
  - b. Install the pressure regulator valve into the bore of the pump cover with the large land and the orifice hole first, positioning with a magnet into the bottom of the bore.
  - c. Install the pressure regulator valve spring into the bore.
  - d. Install the T.V. boost valve into the T.V. bushing. Long land of valve into the large hole of the bushing - retain the valve with petrolatum.
  - e. Install the reverse boost valve into the reverse sleeve, small end of valve first. Retain with petrolatum.
  - f. Using a small magnet install the T.V. boost valve and bushing into the cover with the small hole in the bushing rearward.
  - g. With the T.V. boost valve and bushing compressed and with the snap ring groove visible, install the snap ring.

### Pump Cover and Body Assembly

#### Assembly

1. Place the pump body assembly over a hole in the bench with the stator shaft downward.
2. Assemble the pump cover to pump body with the attaching bolts finger tight.
3. Position the pump cover and pump body using J-21368 and place a holding bolt or screwdriver through a pump to case bolt hole and bench hole. (Fig. 59)
4. Remove tool and torque the pump cover attaching bolts to 22 N·m (18 ft. lbs.).
5. Install a new pump to case gasket on pump and retain with petrolatum.
6. If removed install (2) two teflon oil seal rings on the stator hub. (Fig. 60)
7. Install the pump to case oil seal on the cover - do not twist and make certain seal is properly located. Apply petrolatum.
8. Install a pump cover to case gasket aligning holes. Retain with petrolatum.
9. Install pump to drum thrust washer. (Fig. 61)

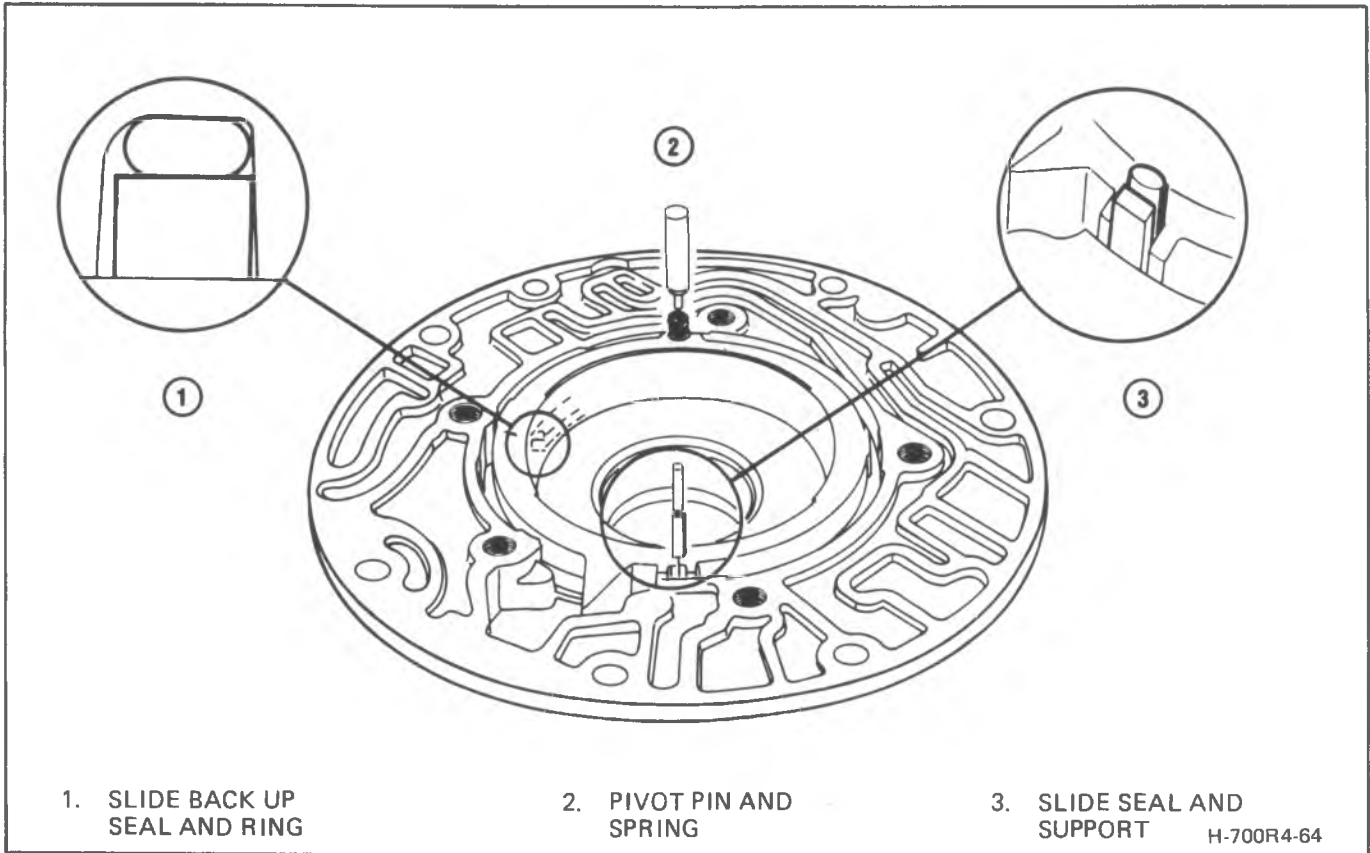

Figure 700-R4-57 Pump Body Assembly

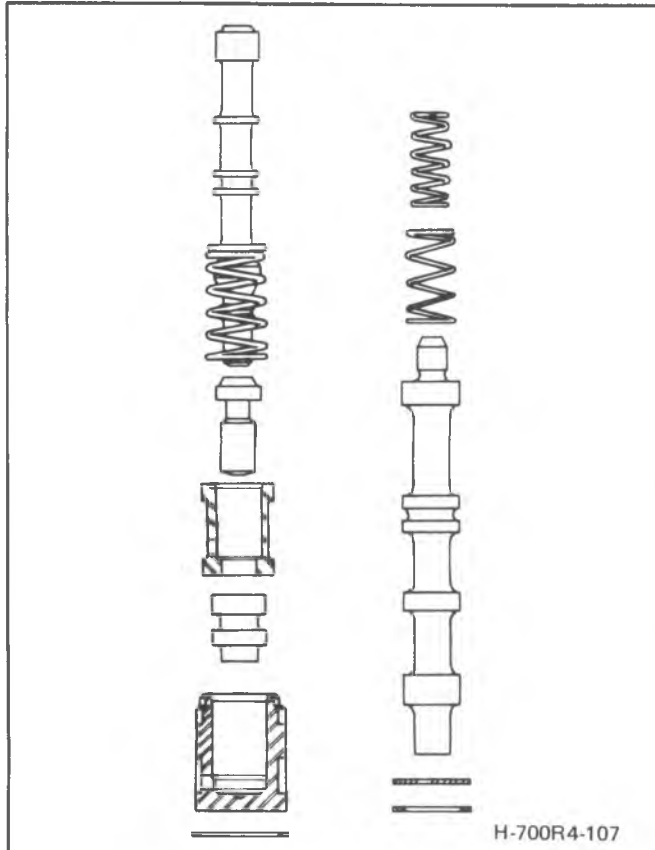

Figure 700-R4-58 Pressure Regulator and Converter Valves

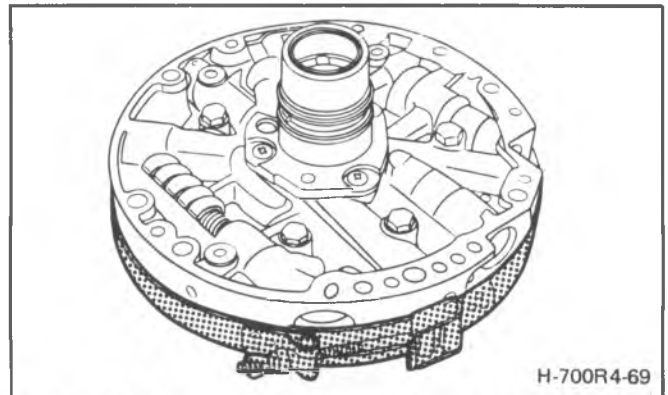

Figure 700-R4-59 Aligning Pump Cover and Body With J-21368

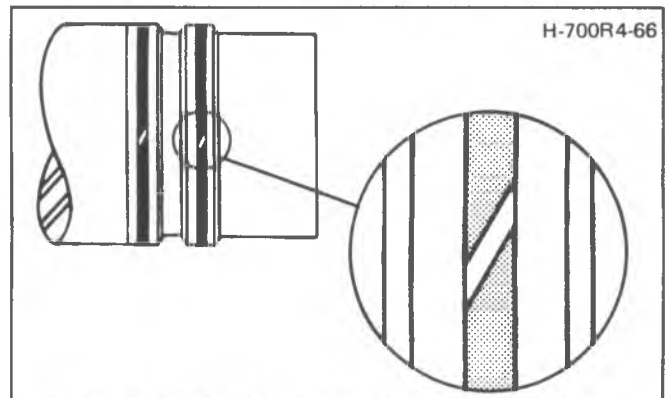

Figure 700-R4-60 Installing Pump Oil Seal Rings

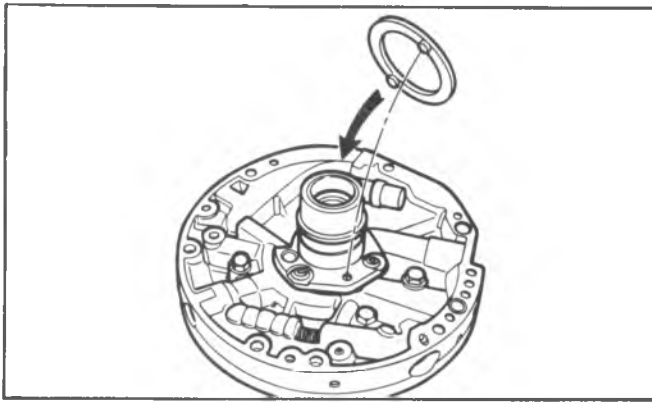

Figure 700-R4-61 Installing Pump to Reverse Input Drum Thrust Washer

**Pump Installation**

1. Install the aligning pins into the case and install the pump, aligning the filter and pressure regulator holes with the case holes and attach with bolts and washers, torquing to 22 N·m (18 ft. lbs.). (Fig. 62)

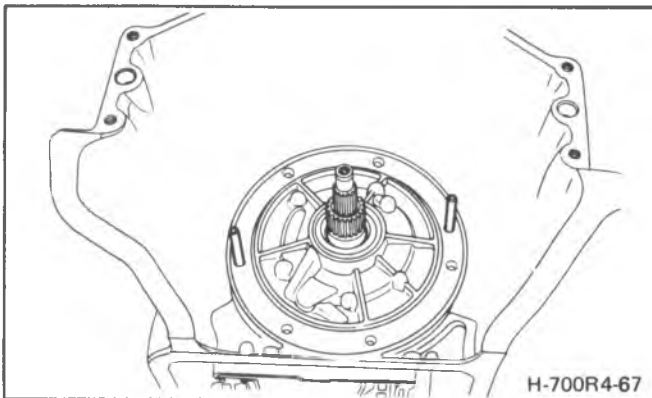

Figure 700-R4-62 Installing Pump With Alignment Pins

Rotate the transmission to a horizontal position and rotate the turbine or output shaft by hand. If it will not rotate, loosen the pump attaching bolts and attempt to rotate again. If the turbine shaft will now turn, the reverse and input assemblies have not been indexed properly or some other assembly problem has occurred, such as a mispositioned washer. Rotate the transmission to a vertical position.

**TRANSMISSION END PLAY CHECK**

1. Remove a pump to case bolt and washer and install a 278 mm (11") bolt and locking nut.
2. Install tool J-25022 on J-24773-A and secure on the end of the turbine shaft.
3. Mount a dial indicator and clamp on the bolt positioning the indicator point cap nut on top of J-24773-5. (Fig. 63)
4. With the dial indicator set at zero, pull upwards. The end play should be 0.13 - 0.92 mm (.005 - .036). The selective washer controlling the transmission end play is located between the input housing and the thrust washer on the pump hub. If more or less end clearance is required to bring the transmission end play within specifications, select the proper washer from the following chart. (Fig. 64)
5. Remove the dial indicator and all tools.
6. Rotate the transmission to a horizontal position.

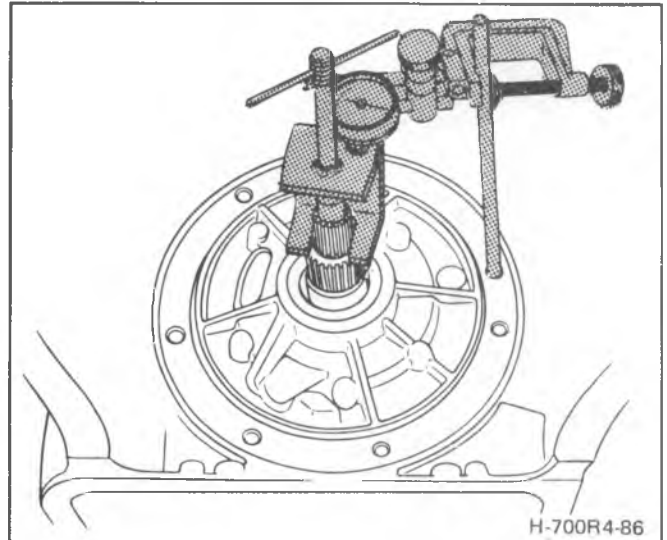

Figure 700-R4-63 Transmission End Play Check

| TRANSMISSION END PLAY WASHER SELECTION CHART |                 | H-700R4-47 |
|--|-----------------|------------|
| WASHER THICKNESS                             |                 | I.D.       |
| 1.87 - 1.97 mm                               | (.074" - .078") | 67         |
| 2.04 - 2.14 mm                               | (.080" - .084") | 68         |
| 2.21 - 2.31 mm                               | (.087" - .091") | 69         |
| 2.38 - 2.48 mm                               | (.094" - .098") | 70         |
| 2.55 - 2.65 mm                               | (.100" - .104") | 71         |
| 2.72 - 2.82 mm                               | (.107" - .111") | 72         |
| 2.87 - 2.99 mm                               | (.113" - .118") | 73         |
| 3.06 - 3.16 mm                               | (.120" - .124") | 74         |

Figure 700-R4-64 Transmission End Play Washer Selection Chart

**VALVE BODY AND WIRING HARNESS**

1. **1-2 Accumulator Assembly**
  - a. Install the 1-2 accumulator pin into the case.
  - b. Install the 1-2 accumulator piston and seal over the pin with the lug end up.
  - c. Install the 1-2 accumulator spring on the piston.
2. **Control Valve Assembly**

(Figs. 65 and 66)

- a. Install the governor and converter clutch oil screens into the case.
- b. Install the (5) five check balls in the transmission case. (Fig. 67)
- c. Install the valve body alignment pins.
- d. Install the spacer plate to case gasket identified with a small "C," on the case.
- e. Install the valve body spacer on the guide pins, aligning holes. (Fig. 68)
- f. Install the valve body to spacer gasket identified with a "V" on the spacer plate.
- g. Install the 3 exhaust balls and check valve into the valve body and retain with petrolatum. (Fig. 69)
- h. Install the valve body, and connect the link to the inside detent lever.
- i. Remove the aligning pins and install the valve body to case attaching bolts and torque to 11 N·m (8 ft. lbs.). (Fig. 70)
- j. Attach the retaining clip to the link and inside detent lever. (Fig. 71)

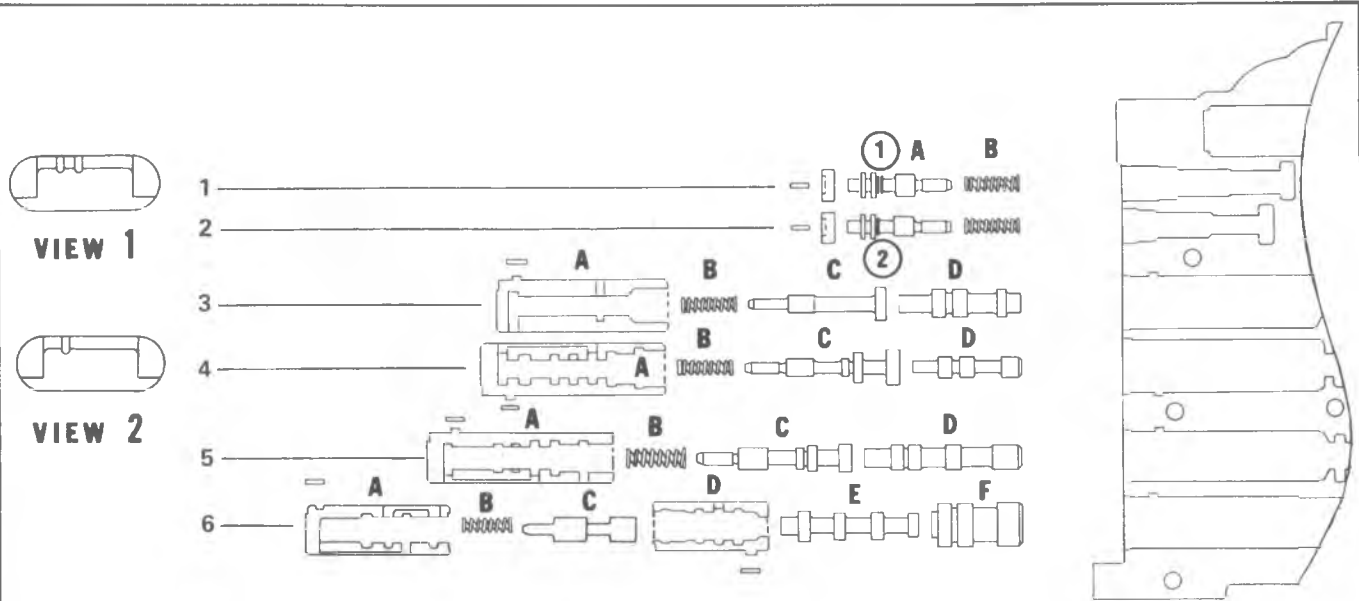

|   |  |  |
|---|--|--|
| <p><b>1</b></p> <p>(A) T.V. Modulator.<br/>(B) T.V. Modulator Downshift Valve Spring.</p>             | <p><b>3</b></p> <p>(A) Converter Clutch Valve Sleeve.<br/>(B) Converter Clutch Throttle Valve Spring.<br/>(C) Converter Clutch Throttle Valve.<br/>(D) Converter Clutch Shift Valve.</p> | <p><b>5</b></p> <p>(A) 2-3 Throttle Valve Sleeve.<br/>(B) 2-3 Throttle Valve Spring.<br/>(C) 2-3 Throttle Valve.<br/>(D) 2-3 Shift Valve.</p>  |
| <p><b>2</b></p> <p>(A) T.V. Modulator Upshift Valve.<br/>(B) T.V. Modulator Upshift Valve Spring.</p> | <p><b>4</b></p> <p>(A) 3-4 Throttle Valve Sleeve.<br/>(B) 3-4 Throttle Valve Spring<br/>(C) 3-4 Throttle Valve.<br/>(E) 3-4 Shift Valve.</p>   | <p><b>6</b></p> <p>(A) 1-2 Throttle Valve Sleeve.<br/>(B) 1-2 Throttle Valve Spring.<br/>(C) 1-2 Throttle Valve.<br/>(D) Lo Range Sleeve.<br/>(E) 1-2 Lo Range Valve.<br/>(F) 1-2 Shift Valve.</p> |

**VALVE BODY DISASSEMBLY**

As each part of the valve train is removed, place the individual part in the order that it was removed and in the same relative location as its true position in the valve body. All parts must be reassembled in the same location as they were removed.

Remove all outside roll pins by pushing through from the rough casting side of the valve body assembly.

Removal of the inner roll pins can be made as follows:

- (a) Grind a taper to one end of the #49 or 1/16 inch drill.
- (b) Lightly tap the tapered end into the roll pin.
- (c) Pull the drill and pin out.

The spring retaining sleeves can be removed by compressing with needle-nose pliers and moving upward through the exposed hole.

Some of the roll pins have applied pressure against them. When removing, care should be taken to prevent the possible loss of parts.

Do not remove the pressure switches unless they require replacement.

Remove the (3) three check balls from the passage side of the body - if present.

Position the valve body machined side up: positioning the manual valve lower right and remove the link and retaining clip, if attached.

**1. T.V. Modular Downshift Valve**

From the No. 1 bore, remove the retaining pin, valve bore plug, T.V. modulator downshift valve and T.V. modulator downshift valve spring.

**2. T.V. Modulator Upshift Valve**

From bore No. 2, remove the retaining pin, valve bore sleeve, T.V. modulator upshift valve and T.V. modulator upshift valve spring.

**3. Converter Clutch Valve**

From bore No. 3, remove the retaining pin. Remove the converter clutch throttle sleeve, converter clutch throttle valve spring and valve, and the converter clutch shift valve.

**4. 3-4 Shift Valve**

From bore No. 4, remove the retaining pin, 3-4 throttle valve sleeve, 3-4 throttle valve spring, 3-4 throttle valve and 3-4 shift valve.

**5. 2-3 Shift Valve**

From bore No. 5, remove the retaining pin. Remove the 2-3 throttle valve sleeve and 2-3 throttle valve spring, 2-3 throttle valve and 2-3 shift valve.

**6. 1-2 Shift Valve**

From bore No. 6, remove the outer roll pin. Remove the 1-2 throttle valve sleeve, 1-2 throttle valve spring, 1-2 throttle valve and lo range valve. Remove the inner retaining pin and remove the lo range valve sleeve and 1-2 shift valve.

H-700R4-12

Figure 700-R4-65 Typical Valve Body Assembly



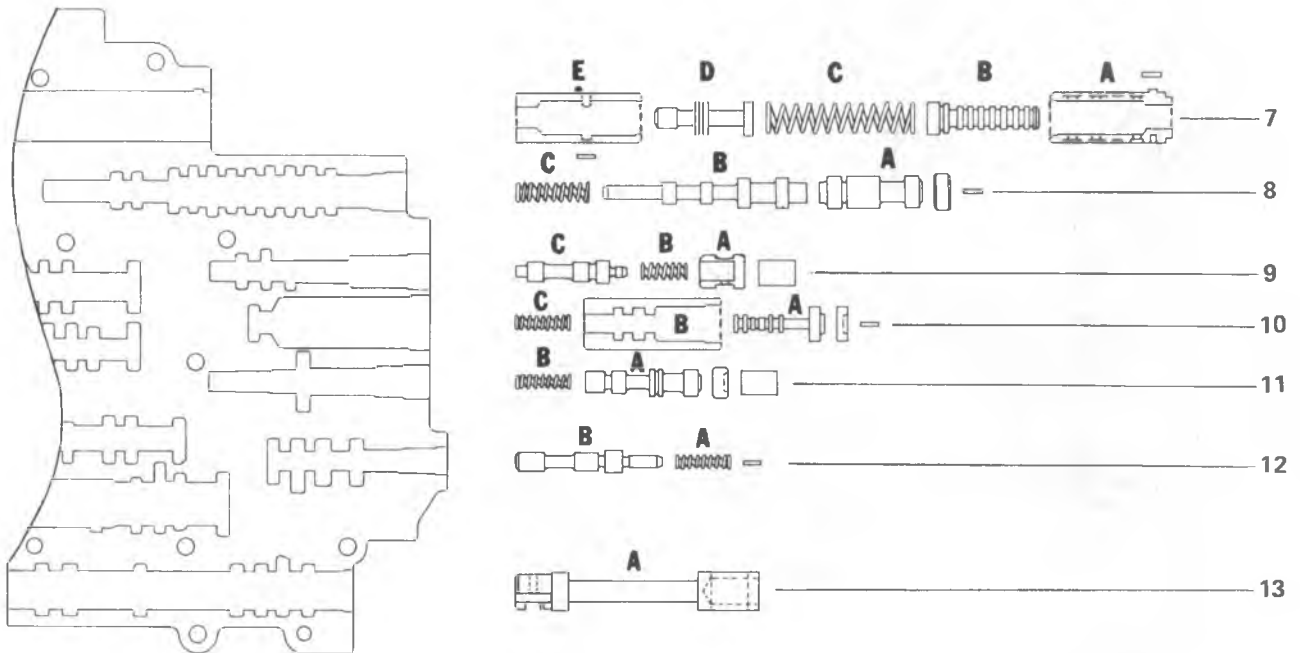

|   |  |  |
|---|--|--|
| <p>7 (A) Throttle Valve Plunger Sleeve.<br/>(B) Throttle Valve Plunger.<br/>(C) Throttle Valve Spring.<br/>(D) Throttle Valve.<br/>(E) Throttle Valve Sleeve.</p> | <p>9 (A) T.V. Limit Plug.<br/>(B) T.V. Limit Valve Spring.<br/>(C) T.V. Limit Valve.</p> | <p>11 (A) Line Bias Valve.<br/>(B) Line Bias Spring.</p>   |
| <p>8 (A) 3-4 Relay Valve.<br/>(B) 4-3 Sequence Valve.<br/>(C) 4-3 Sequence Valve Spring.</p>  | <p>10 (A) Accumulator Valve.<br/>(B) Accumulator Sleeve.<br/>(C) Accumulator Spring.</p> | <p>12 (A) 3-2 Control Valve Spring.<br/>(B) 3-2 Control Valve.<br/><br/>13 (A) Manual Valve.</p> |

**7. Throttle Valve Assembly**

From bore No. 7, remove the outer roll pin from the rough casting side, the throttle valve plunger sleeve, throttle valve plunger and throttle valve spring. Remove the inner roll pin and valve.

**8. 3-4 Relay and 4-3 Sequence Valve**

From bore No. 8, remove the retaining roll pin and plug. Remove the 3-4 relay valve, 4-3 sequence valve and spring.

**9. T.V. Limit Valve**

From bore No. 9, using needle nose pliers, compress and remove the spring retainer. Remove the T.V. limit plug and spring valve.

**10. T.V. Accumulator Valve**

From bore No. 10, remove the retaining roll pin and plug. Remove the 1-2 accumulator valve, spring and sleeve.

**11. Line Bias Valve**

From bore No. 11, using needle nose pliers, compress the line bias valve spring retainer and remove the plug, line bias and spring.

**12. 3-2 Control Valve**

From bore No. 12, remove the roll pin, 3-2 control valve spring and 3-2 control valve.

**13. Remove the manual valve from bore No. 13.**

**INSPECTION**

1. Wash the control valve body, clean solvent and air dry. Clean valve train parts one at a time, place in the same position as they were removed and inspect as follows:  
Inspect valve for scoring, cracks and free movement in their bores.  
Inspect all bushings for cracks or scored bores.  
Inspect the valve body for cracks, damage or scored bores.  
Lands should be flat with no cross leaks.

**ASSEMBLY**

Install all parts in the reverse order as they were removed Assemble all bore plugs against the retaining pins with the recessed holes outboard. All the roll pins must be installed so they do not extend above the flat machined face of the valve body pad. Install all flared coiled pins with the flared end out.

Make certain all retaining or roll pins are installed into the proper locating slots in the sleeves, Not in the oil passage holes.

The bushing for the 1-2 accumulator valve train must be assembled with the small hole for the roll pin facing the rough casting side of the valve body.

Figure 700-R4-66 Typical Valve Body Assembly



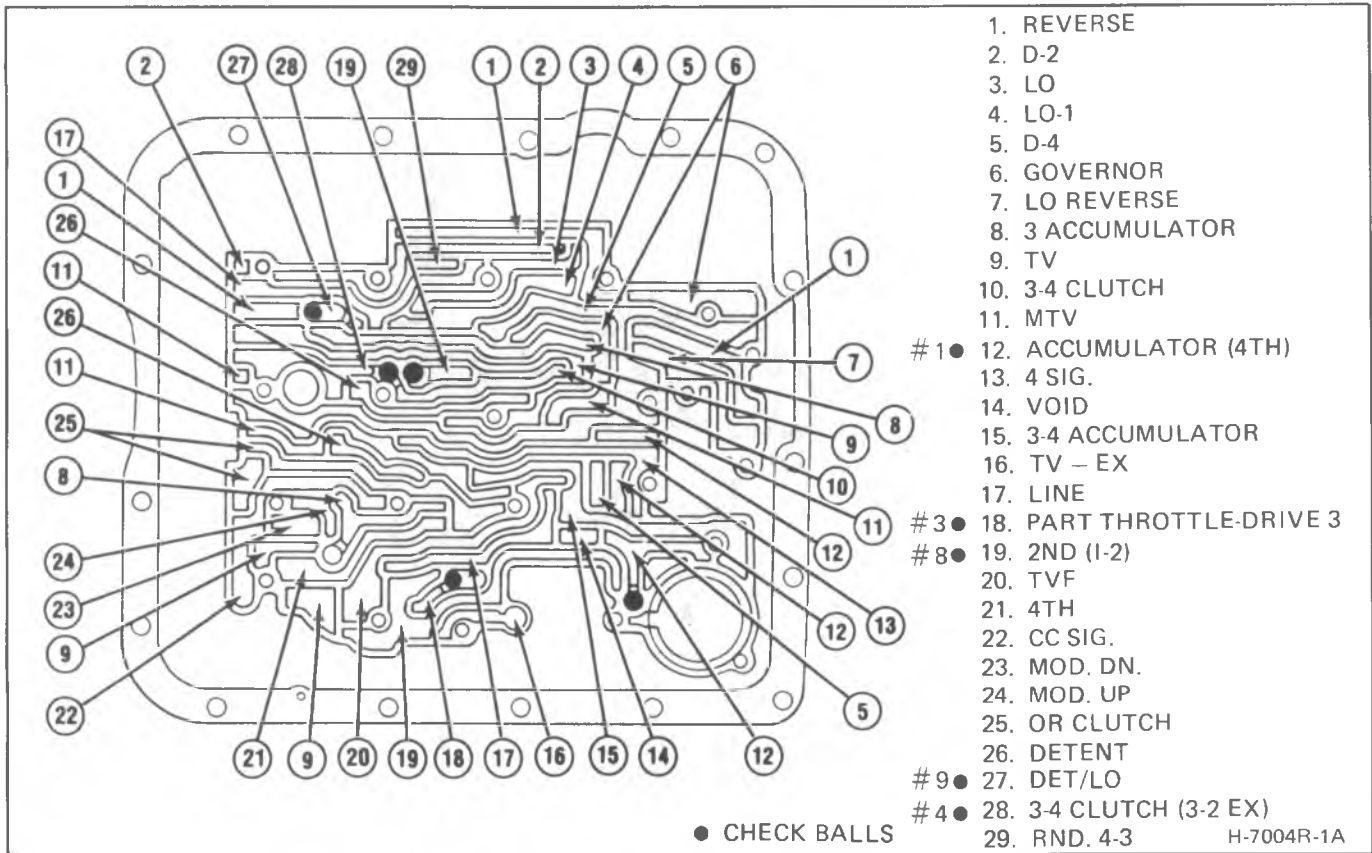

Figure 700-R4-67 Case Check Balls and Oil Passages

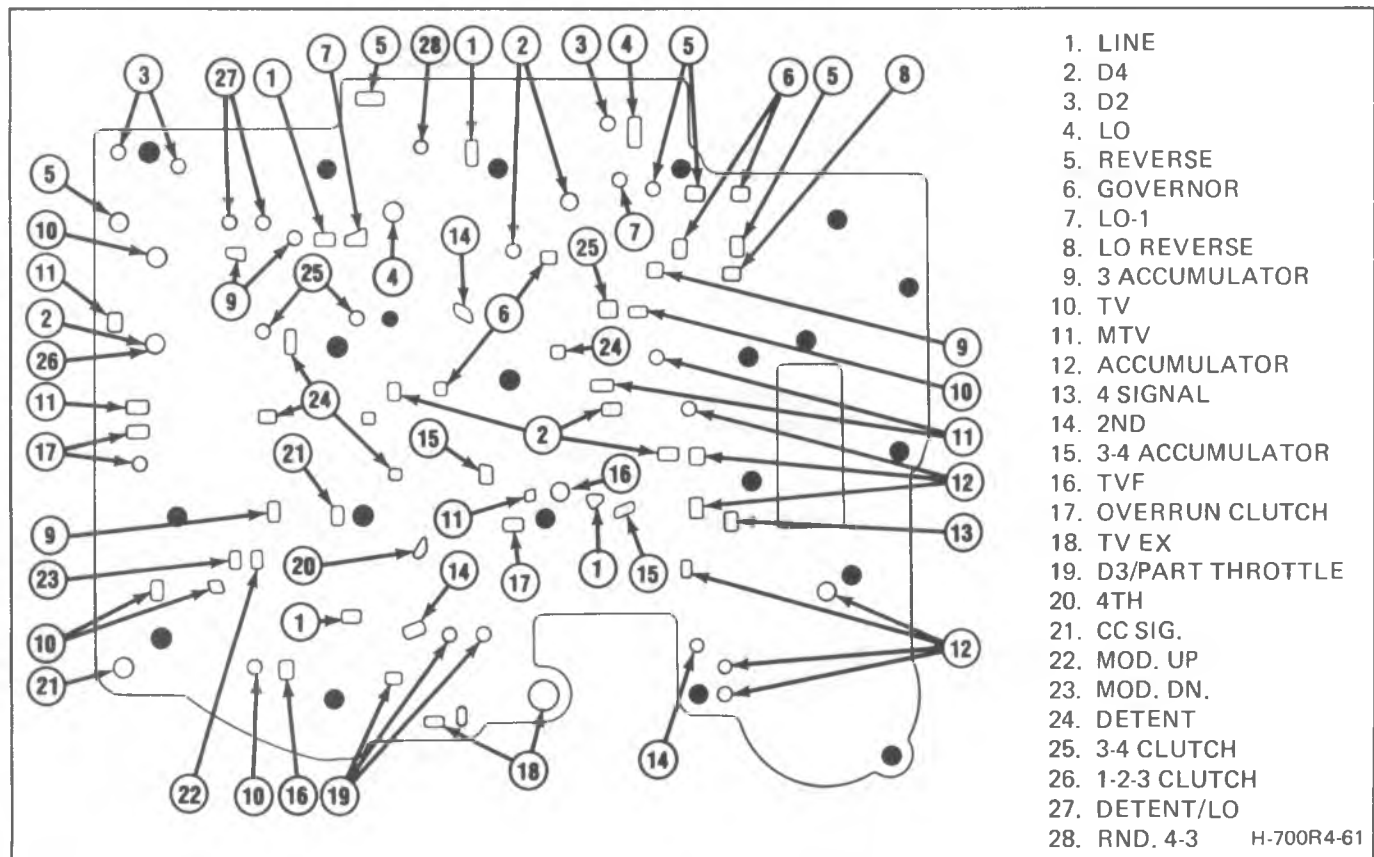

Figure 700-R4-68 Spacer Plate I.D.

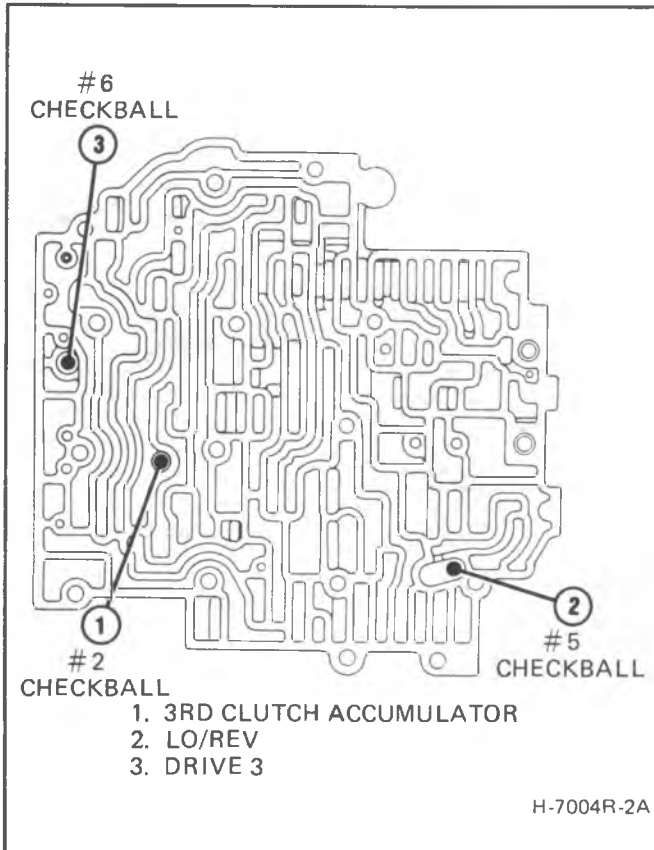

Figure 700-R4-69 Valve Body Check Ball Locations

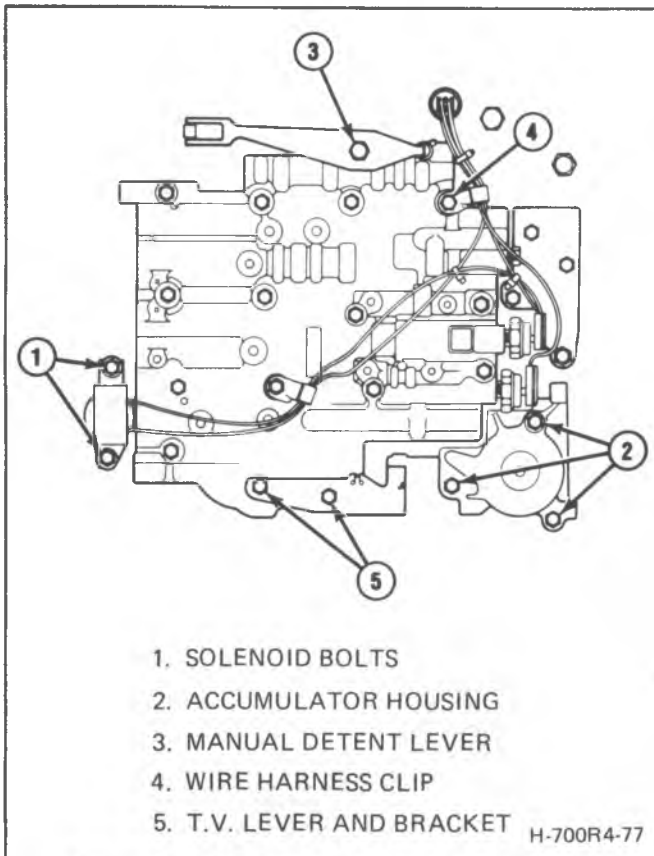

Figure 700-R4-70 Valve Body Bolt Locations

3. Install the throttle lever and bracket, and T.V. link locating the slot in the bracket with the roll pin on the

valve body top face, aligning the link through the T.V. linkage case bore. Attach with (2) two valve body to case bolts and torque to 11 N·m (8 ft. lbs.). (Fig. 72)

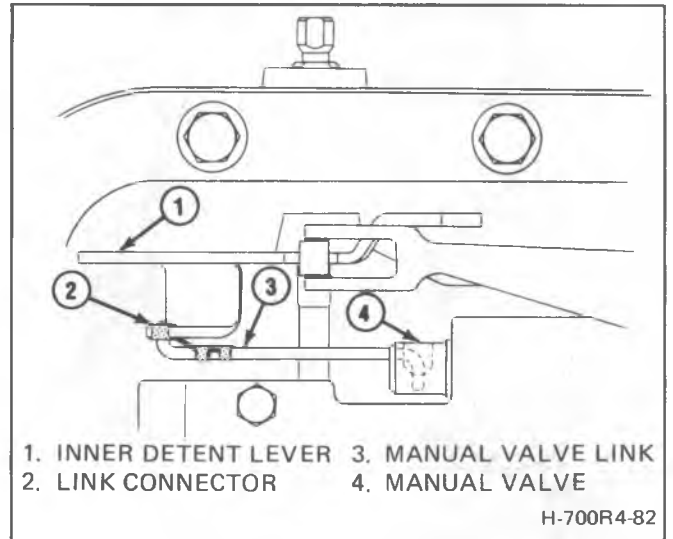

Figure 700-R4-71 Manual Valve Link and Clips

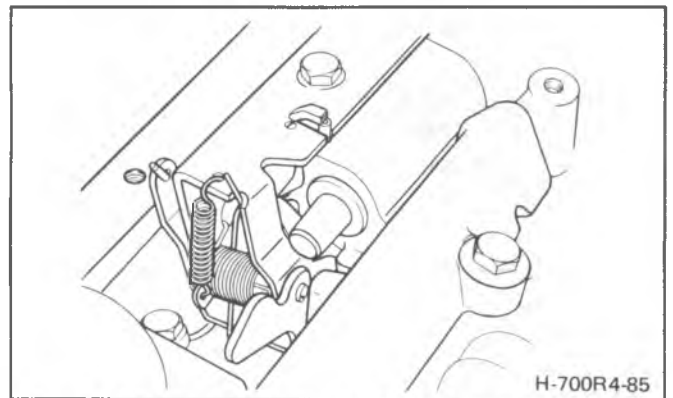

Figure 700-R4-72 Installing the T.V. Bracket and Lever Assembly

4. Install the valve body attaching bolt and harness clip and torque to 11 N·m (8 ft. lbs.).
5. Install the parking pawl bracket and torque to 22 N·m (18 ft. lbs.).
6. Install the manual detent spring and roller assembly with an attaching bolt and torque to 11 N·m (8 ft. lbs.).
7. Install the "O" Ring on the solenoid assembly and install into the pump, locating the attaching wire harness toward the transmission, attaching with (2) two bolts and torque to 22 N·m (18 ft. lbs.).
8. Install the wiring harness and connect to all pressure switches. (Figs. 73 and 74)

**EACH PRESSURE SWITCH WILL BE COLOR CODED FOR SWITCH AND WIRE CONNECTOR IDENTIFICATION. WHEN CONNECTING THE WIRE CONNECTORS TO THE PRESSURE SWITCHES, ALWAYS CONNECT THE SAME COLORS. IT IS NOT NECESSARY TO CONNECT THE SAME WIRE CONNECTOR TO THE SAME PRESSURE SWITCH TERMINALS AS THEY ARE REVERSIBLE.**

9. Install the "O" Ring on the outside electrical connector and install into the case by compressing the inside tang or gently taping in board, locating the tab with the case notch.

700-R4-40 AUTOMATIC TRANSMISSION

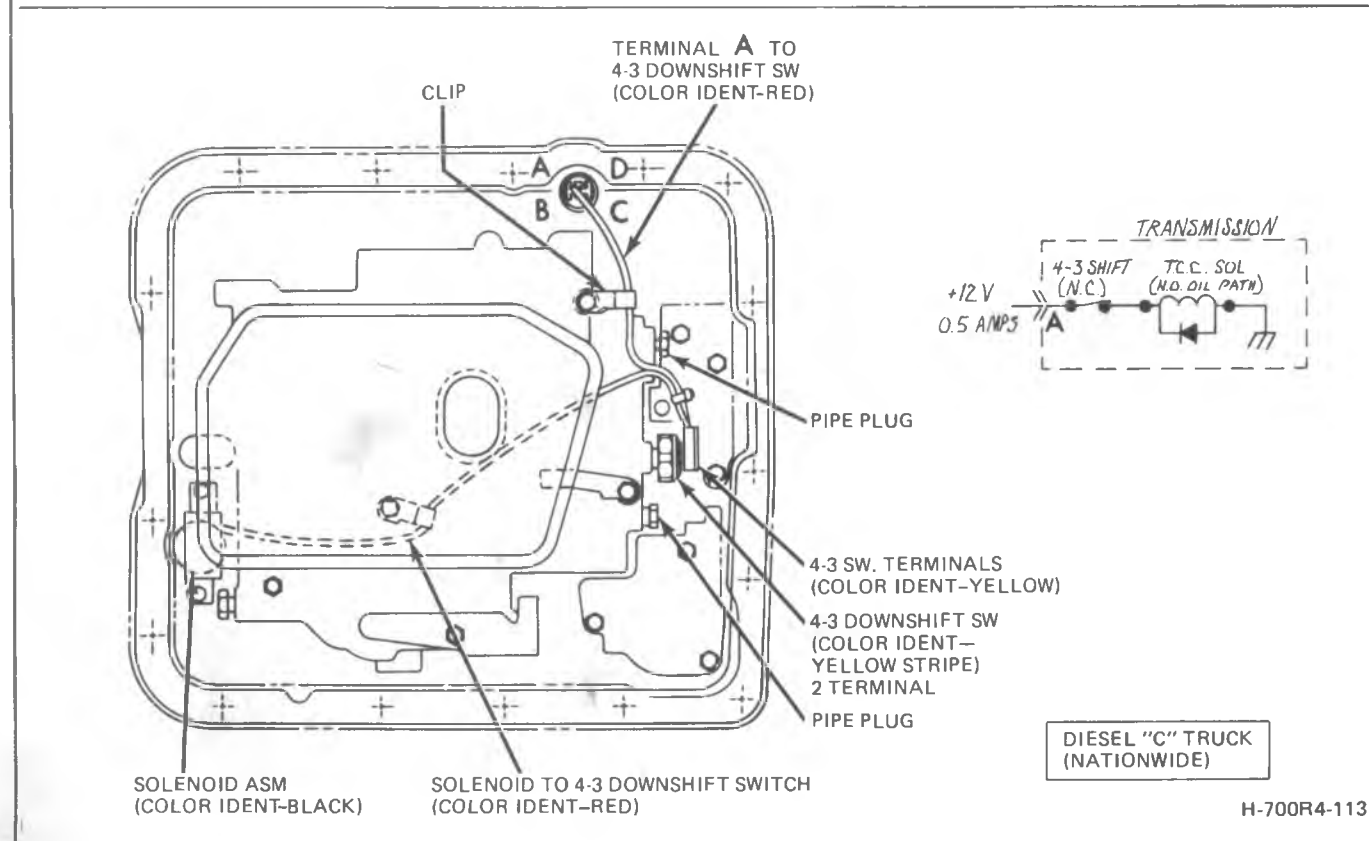
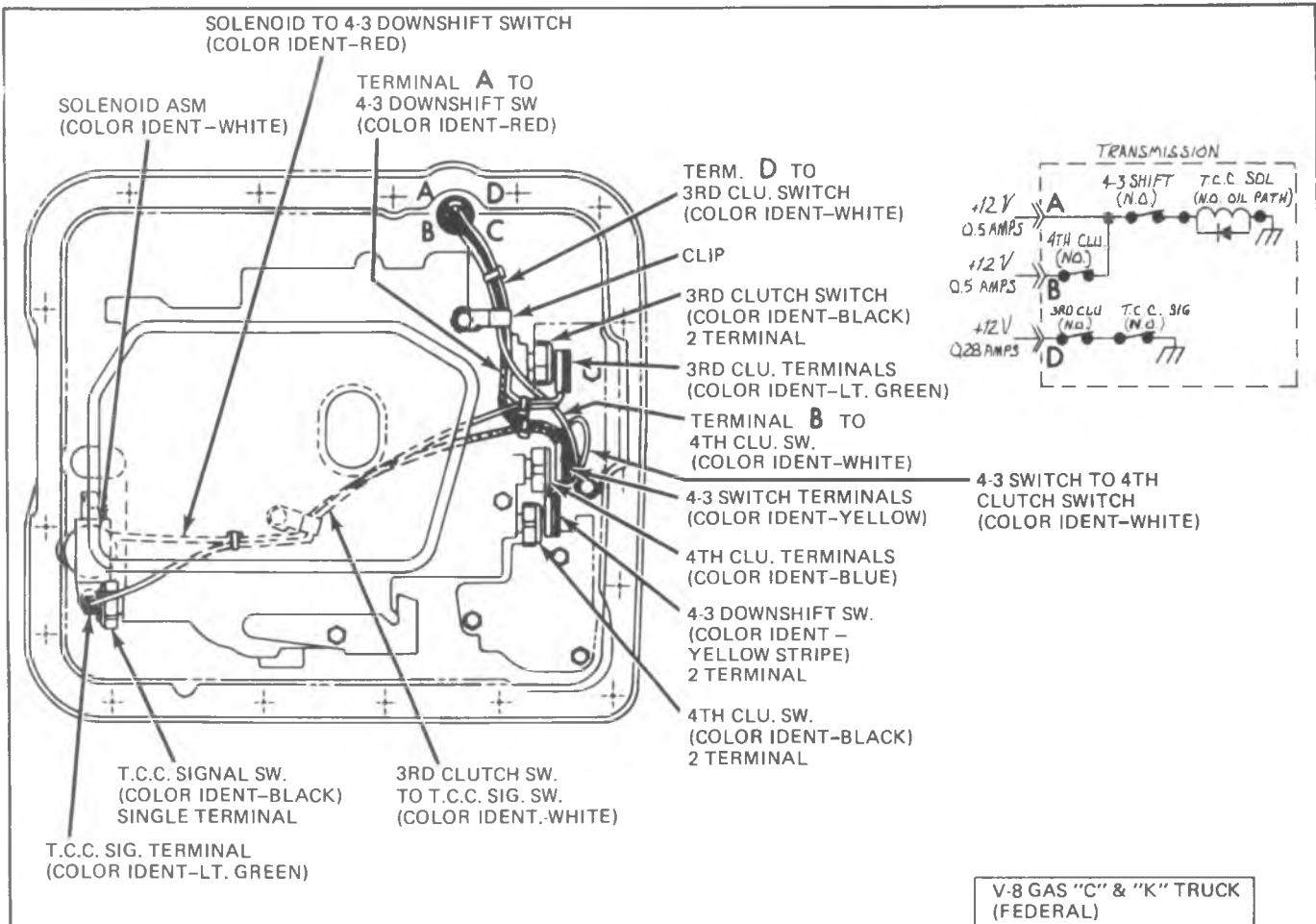

Figure 700-R4-73 Wiring Harness

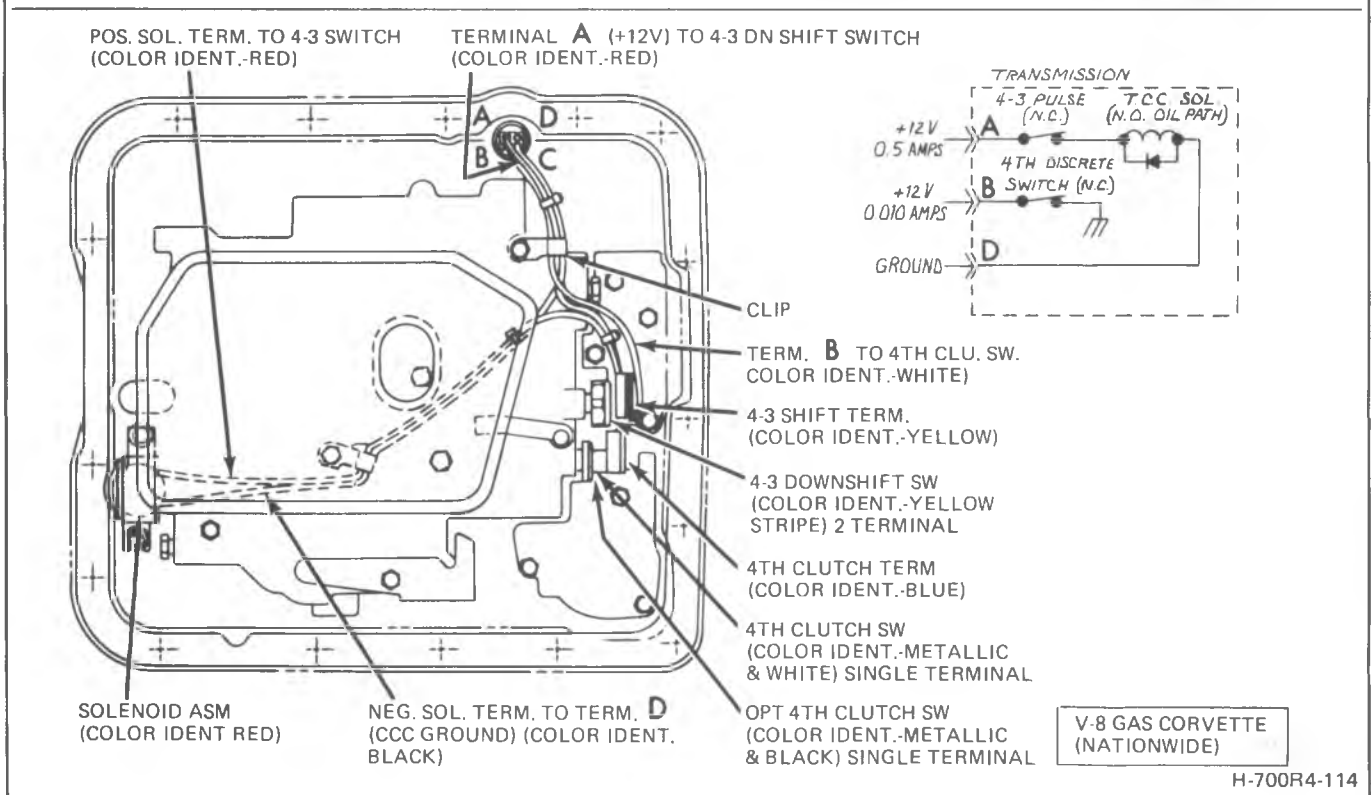
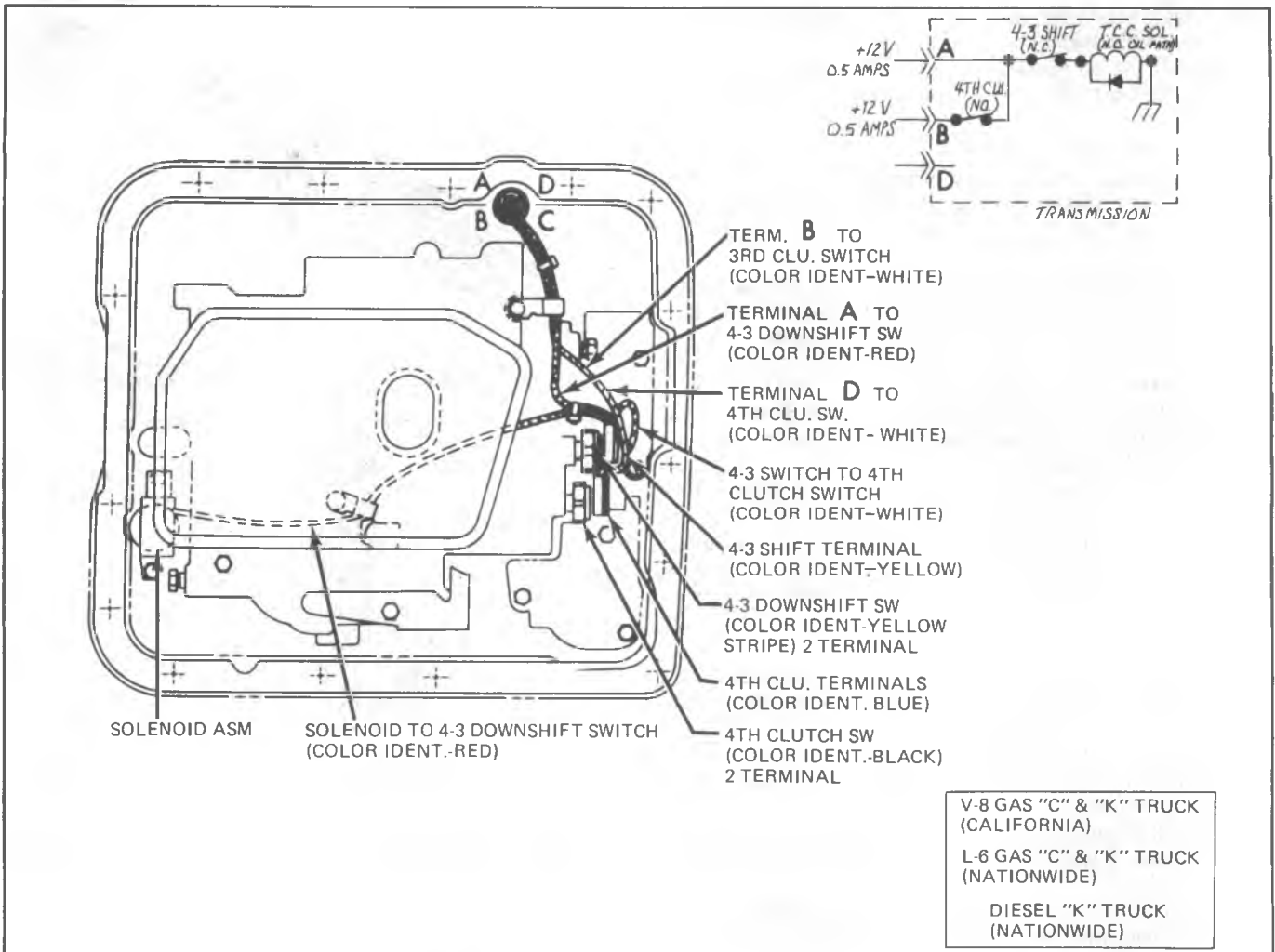

Figure 700-R4-74 Wiring Harness

## 700-R4-42 AUTOMATIC TRANSMISSION

10. Attach the inside electrical connector terminal to the outside electrical connector.
11. Install the oil passage cover on the transmission with (3) three attaching bolts and torque to 11 N·m (8 ft. lbs.).
12. 3-4 Accumulator Assembly
  - A. Install the 3-4 accumulator piston into the accumulator housing with the lug end up.
  - B. Install the 3-4 accumulator piston spring into the housing on the piston.
  - C. Position the 3-4 accumulator plate and gasket on the transmission positioning the gasket on top.
  - D. Install the housing, spring and piston on the transmission case and secure with (3) three attaching bolts, torquing to 11 N·m (8 ft. lbs.).
13. Install the speedo gear and retaining clip on the output shaft, positioning the large notch on the speedo gear rearward. (Fig. 75)
14. Install the output shaft seal in the output shaft sleeve and install on the output shaft with J25016. (Fig. 76)
15. Install the oil seal ring on the case extension and install on case. Positioning so the speedo hole is located on the same side as the governor. Torque bolts to 31 N·m (23 ft. lbs.).
16. Install the governor assembly.
17. Apply a sealant, such as loctite cup plug sealant No. 11 or equivalent to the edge of the cover, then install cover.

**Use care to prevent damage.**
18. Install the "O" Ring on the filter and install in the transmission.
19. Install a new oil pan gasket on the transmission case and install the attaching bolts and torque to 11 N·m (8 ft. lbs.).
20. Install all remaining outside connectors such as driven speedo gear and adaptor, outside manual lever and nut.

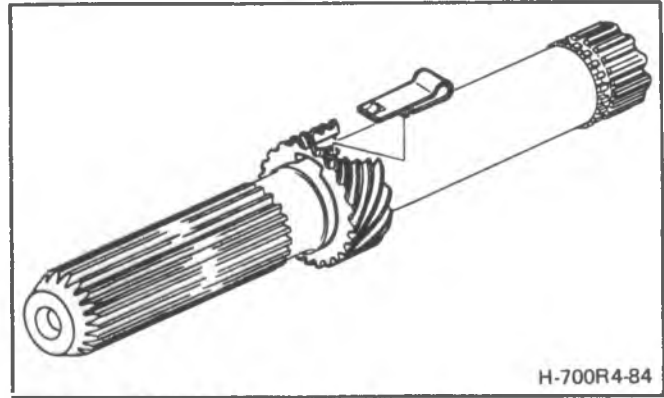

Figure 700-R4-75 Installing Speedo Gear and Clip

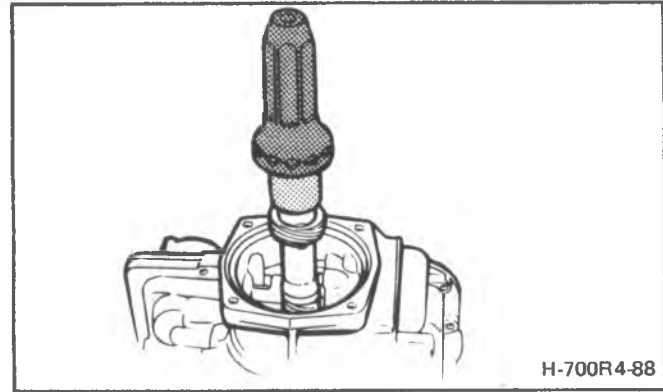

Figure 700-R4-76 Installing Output Shaft Sleeve

21. Remove the transmission from the holding fixture and install the torque converter.

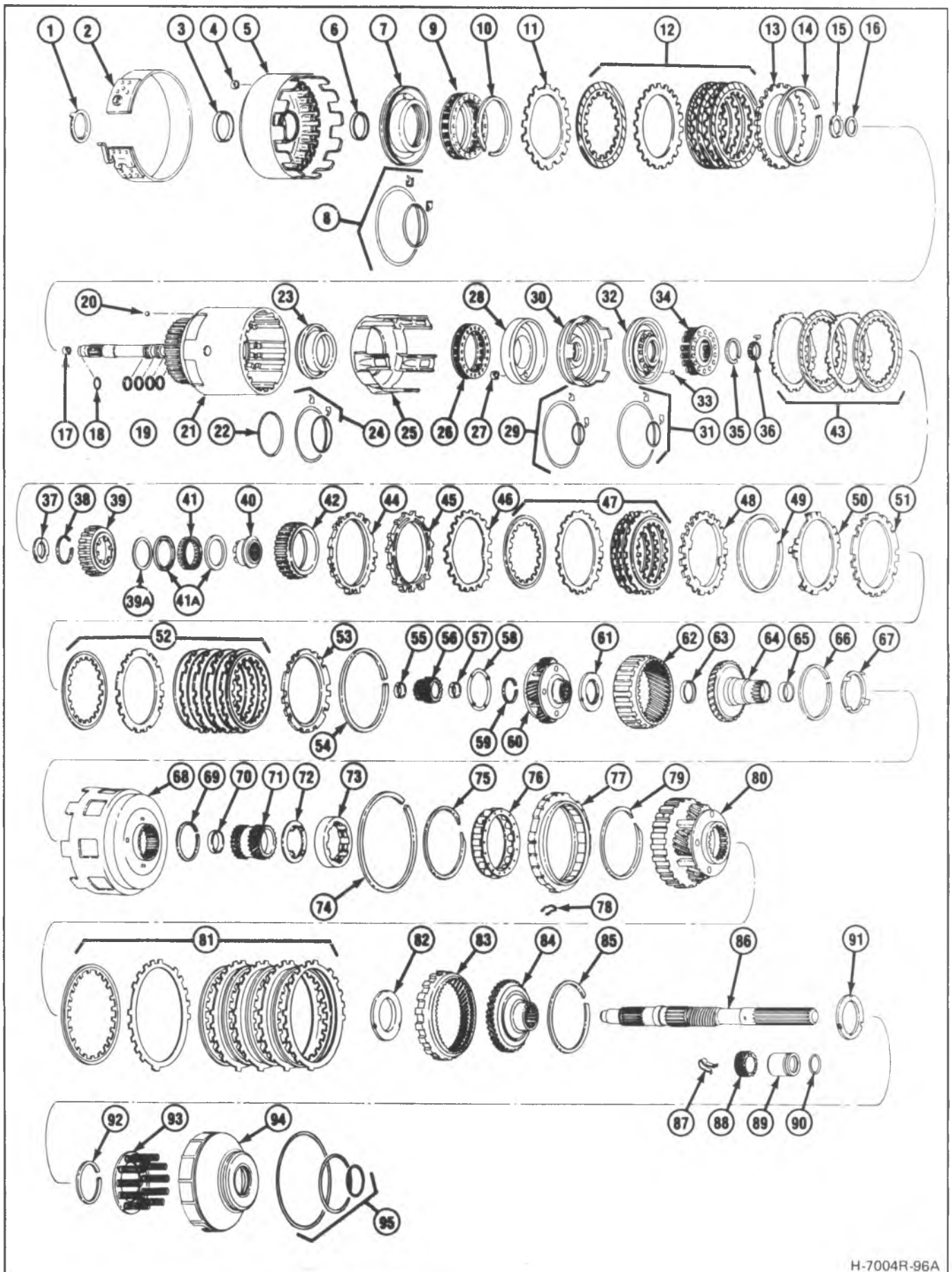
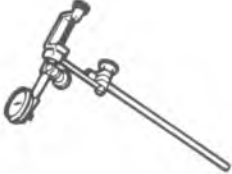





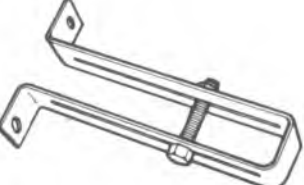



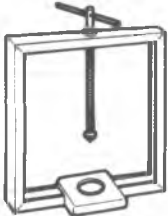



Figure 700-R4-77 Transmission Assembly



700-R4-46 AUTOMATIC TRANSMISSION

|   |   |  |   |
|---|---|--|---|
|    | <p>J-8001<br/>DIAL INDICATOR SET</p>                      |    | <p>J-8763-02<br/>HOLDING FIXTURE<br/>AND BASE</p>                           |
|    | <p>J-23327<br/>CLUTCH SPRING<br/>COMPRESSOR</p>           |     | <p>J-22269-01<br/>PISTON COMPRESSOR</p>                                     |
|    | <p>J-25018-A<br/>CLUTCH SPRING<br/>COMPRESSOR ADAPTOR</p> |    | <p>J-24773-A<br/>OIL PUMP REMOVER<br/>AND END PLAY<br/>CHECKING FIXTURE</p> |
|    | <p>J-29714<br/>SERVO COVER<br/>COMPRESSOR</p>             |     | <p>J-25022<br/>END PLAY CHECKING<br/>FIXTURE ADAPTOR</p>                    |
|    | <p>J-29837<br/>OUTPUT SHAFT<br/>SUPPORT FIXTURE</p>       |   | <p>J-29882<br/>INNER OVERRUN<br/>CLUTCH SEAL<br/>PROTECTOR</p>              |
|  | <p>J-25016<br/>PUMP OIL SEAL<br/>INSTALLER</p>            |   | <p>J-29883<br/>INNER FORWARD<br/>CLUTCH SEAL<br/>PROTECTOR</p>              |
|  | <p>J-21426<br/>REAR SEAL<br/>INSTALLER</p>                |  | <p>J-33037<br/>2-4 BAND<br/>APPLY PIN TOOLS</p>                             |
|  | <p>J-23456<br/>CLUTCH SPRING<br/>COMPRESSOR PRESS</p>     |  | <p>J-21368<br/>OIL PUMP BODY<br/>AND COVER<br/>ALIGNMENT BAND</p>           |

H-7004R-104A

Figure 700-R4-80 Special Tools

## SECTION 7B

# MANUAL TRANSMISSION

### CONTENTS

|                                   |      |
|-----------------------------------|------|
| General Description.....          | 7B-1 |
| Maintenance and Adjustments ..... | 7B-2 |
| Free Pedal Travel .....           | 7B-3 |
| Spin Down Time.....               | 7B-3 |
| Shift Effort.....                 | 7B-4 |
| Transmission Alignment.....       | 7B-5 |
| Diagnosis.....                    | 7B-6 |
| 76MM (3 Speed).....               | 1    |
| 89MM (4 Speed).....               | 1    |
| 117MM (4 Speed).....              | 1    |

## GENERAL DESCRIPTION

### THREE-SPEED TRANSMISSIONS

#### 3-Speed 76mm (7B1-4)

Manual transmissions are designated according to: (A) the number of forward gears, and (B) the measured distance between centerlines of the mainshaft and the countergear.

The three speed synchromesh transmission are representative of a constant-mesh transmission design. Fundamental components of these units are the case, which house the gears and shaft; the shift control mechanism and the various shafts and gears. The input shaft has an integral main drive gear and rotates with the clutch driven plate; that is, the shaft rotates all the time the clutch is engaged and the engine is running. The input shaft is supported in the case by a ball bearing and at the front end by an oil impregnated bushing mounted in the engine crankshaft. The drive gear is in constant mesh with the countershaft drive gear. Since all gears in the countershaft cluster are integral to the shaft, they also rotate at the time the clutch is engaged. The countergear is carried on roller bearings at both ends and thrust is absorbed by thrust washers located between the countergear and thrust bosses in the case. The transmission mainshaft is held in line with the input shaft by a pilot bearing at its front end, which allows it to rotate or come to rest independently of the input shaft. In the 76mm unit, the mainshaft is carried at the rear by a ball bearing mounted in the front face of the extension housing.

Helical gears are incorporated throughout the transmission. The mainshaft gears are free to rotate independently on the mainshaft and are in constant mesh with the countershaft gears. The reverse idler gear is carried on a bushing, finish bored in place, and thrust is taken on the thrust bosses of the case.

The transmission is fully synchronized in all forward speeds; however, reverse gear is not. The synchronizer assemblies consist of a hub, sleeve, two key springs and three synchronizer keys. The synchronizer hubs are splined to the mainshaft and retained by snap rings. These assemblies permit gears to be selected without clashing, by synchronizing the speeds of mating parts before they engage.

In the 76mm unit, the driven gear, second speed gear, first speed gear and reverse gear are rigidly connected to the countergear. driven clutch gear drives the countergear through a constant mesh countershaft driven gear. The countergear rotates in a direction opposite, or counter, to the rotation of the clutch gear. Forward speed gears on the countergear remain in constant mesh with two nonsliding mainshaft gears giving first and second speed. Third speed is a direct drive with the clutch gear engaged directly to the mainshaft. Forward gears are engaged through two sliding synchronizer sleeves mounted on the mainshaft. Engagement of the constant mesh mainshaft gears to the mainshaft is accomplished through blocker ring-type synchronizers.

### FOUR-SPEED TRANSMISSION

#### 4-Speed 89mm (Fig. 7B3-4)

The four speed transmission with overdrive has an 89mm center distance and is designed to combine normal performance in the city with improved fuel economy on the highway. Gear ratios are: first 3.09 to 1; second 1.67 to 1; third 1.00 to 1; fourth (overdrive) 0.73 to 1. All forward gears are fully synchronized. The synchronizer assemblies consist of a hub, sleeve, two key springs and three synchronizer keys. The synchronizer hubs are splined to the mainshaft and retained by snap rings. These assemblies permit gears to be selected without clashing, by synchronizing the speeds of mating parts before they engage.

The drive pinion (input shaft) is supported by a ball bearing in the transmission case and an oil impregnated bushing pressed in the end of the crankshaft.

The mainshaft front end is supported by roller bearings in the end of the main drive pinion and a ball bearing in the front of the extension housing. The output end of the mainshaft is splined to the sliding universal joint yoke, which is supported by a bushing in the extension housing.

The countershaft gear is supported by a double row of needle type roller bearings at each end and the thrust is taken on thrust washers between the ends of the gear and the transmission case. The alignment of the needle type roller bearings within the gear is maintained by a tubular spacer in



the center and four thrust washers (one being used between the rows of roller bearings and one at each end). The countershaft is not a press fit in the case bores, but has .127mm (.005 inch) diameter clearance. An expansion plug is pressed into a counter bore at the front of the case to prevent oil leakage around the countershaft.

The reverse idler gear is supported on a bronze bushing, pressed into the gear. A magnetic disc is attached to bottom, near rear of case under countershaft gear. This magnet collects and prevents circulation of chips in transmission oil.

**4-Speed 117mm (Fig. 7B4-4)**

The 117mm, Model CH 465 truck transmission uses a constant mesh first gear that engages with the second speed synchronizer sleeve. Second, third and fourth gears are synchronized. The clutch gear is supported by a heavy duty ball bearing. The forward end of the mainshaft is supported

by a loose collar-type bearing inside the clutch gear, while the rear is carried on a ball bearing in the case. End play is taken up by the rear flange retaining nut. The countergear is supported at the rear of a single row ball bearing which takes the thrust load, and by a roller bearing at the front. Incorporated in the cover is a ball pin type interlock which prevents simultaneous engagement of two gears. As one rod is moved, it pushes a ball out that engages the other two rods to prevent their movement.

Gearshift levers on manual transmissions are located either on the steering column or on the floorpan. Regardless of location, the lever performs two operations: It selects the gear assembly to be moved, and moves it either forward or backward into the desired gear position. The transmission action is the same whether a floor-type shift lever or a steering column shift lever is used. When the shift lever is moved, the movement is carried by linkage to the transmission.

**MAINTENANCE AND ADJUSTMENTS**

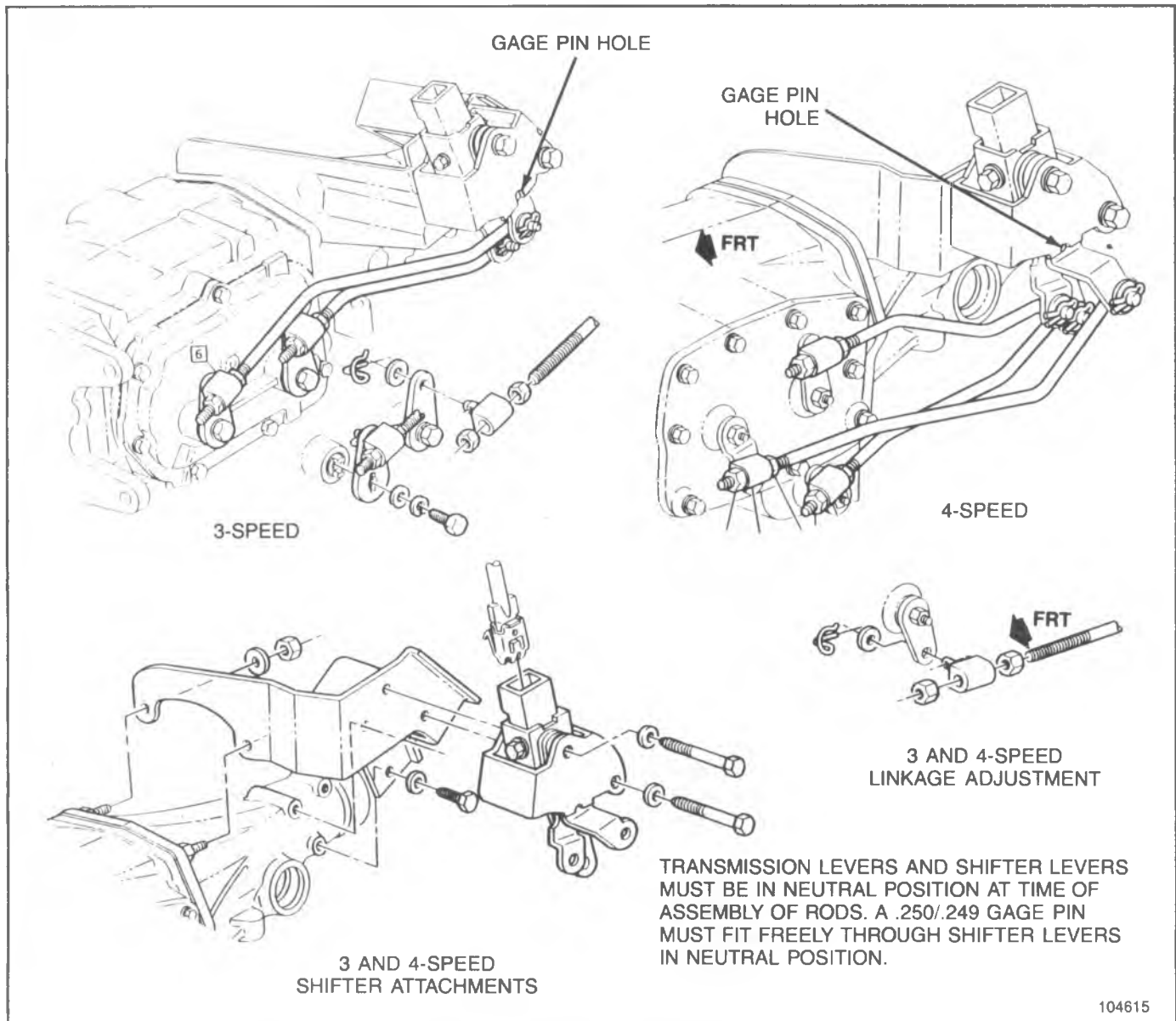
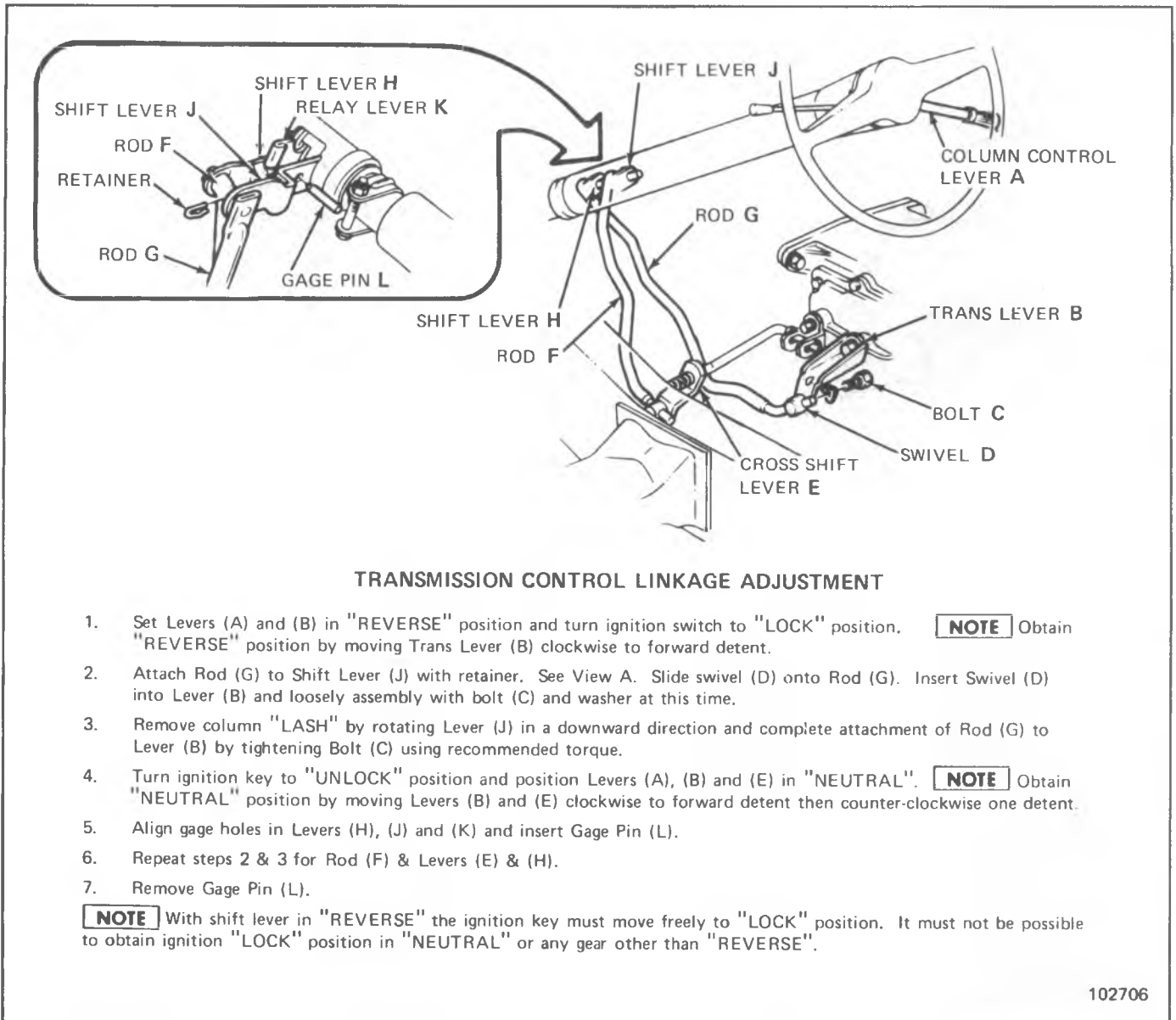

Fig. 7B-1--G-Truck Shift Linkage



**TRANSMISSION CONTROL LINKAGE ADJUSTMENT**

1. Set Levers (A) and (B) in "REVERSE" position and turn ignition switch to "LOCK" position. **NOTE** Obtain "REVERSE" position by moving Trans Lever (B) clockwise to forward detent.
2. Attach Rod (G) to Shift Lever (J) with retainer. See View A. Slide swivel (D) onto Rod (G). Insert Swivel (D) into Lever (B) and loosely assembly with bolt (C) and washer at this time.
3. Remove column "LASH" by rotating Lever (J) in a downward direction and complete attachment of Rod (G) to Lever (B) by tightening Bolt (C) using recommended torque.
4. Turn ignition key to "UNLOCK" position and position Levers (A), (B) and (E) in "NEUTRAL". **NOTE** Obtain "NEUTRAL" position by moving Levers (B) and (E) clockwise to forward detent then counter-clockwise one detent.
5. Align gage holes in Levers (H), (J) and (K) and insert Gage Pin (L).
6. Repeat steps 2 & 3 for Rod (F) & Levers (E) & (H).
7. Remove Gage Pin (L).

**NOTE** With shift lever in "REVERSE" the ignition key must move freely to "LOCK" position. It must not be possible to obtain ignition "LOCK" position in "NEUTRAL" or any gear other than "REVERSE".

102706

Fig. 7B-2--C Truck Column Shift Linkage

Before attempting to repair the clutch, transmission or related linkages for any reason other than an obvious failure, the problem and probable cause should be identified. A large percentage of clutch and manual transmission problems are manifested by shifting difficulties such as high shift effort, gear clash and grinding or transmission blockout. When any of these problems occur a careful analysis of these difficulties should be accomplished, and the following checks and adjustments performed in the presented sequence before removing the clutch or transmission for repairs.

**CLUTCH ADJUSTMENT**

**Clutch Free Pedal Travel**

1. The clutch free pedal travel adjustment should be made as outlined in Section 7C.
2. Check clutch linkage for lost motion caused by loose or worn swivels, deflection of mounting brackets or damaged cordon shaft.

**Clutch Spin Down Time**

1. Run the engine at a normal idle with transmission in neutral and clutch engaged.
2. Disengage the clutch, wait nine seconds and shift the transmission to reverse. No grinding noise should be heard. A grinding noise indicates incorrect clutch adjustment, lost motion, clutch misalignment, or internal problems such as failed dampers, facings, cushion springs, diaphragm spring fingers, pressure plate drive straps, etc.

**SHIFT LINKAGE ADJUSTMENT**

**Steering Column Shift Control**

1. Remove the shift control rods from the column levers.
2. Check shift effort at the shift control lever knob. (Effort should not exceed 2 lb. with transmission linkage removed.)
3. If binding is felt, refer to the adjustment

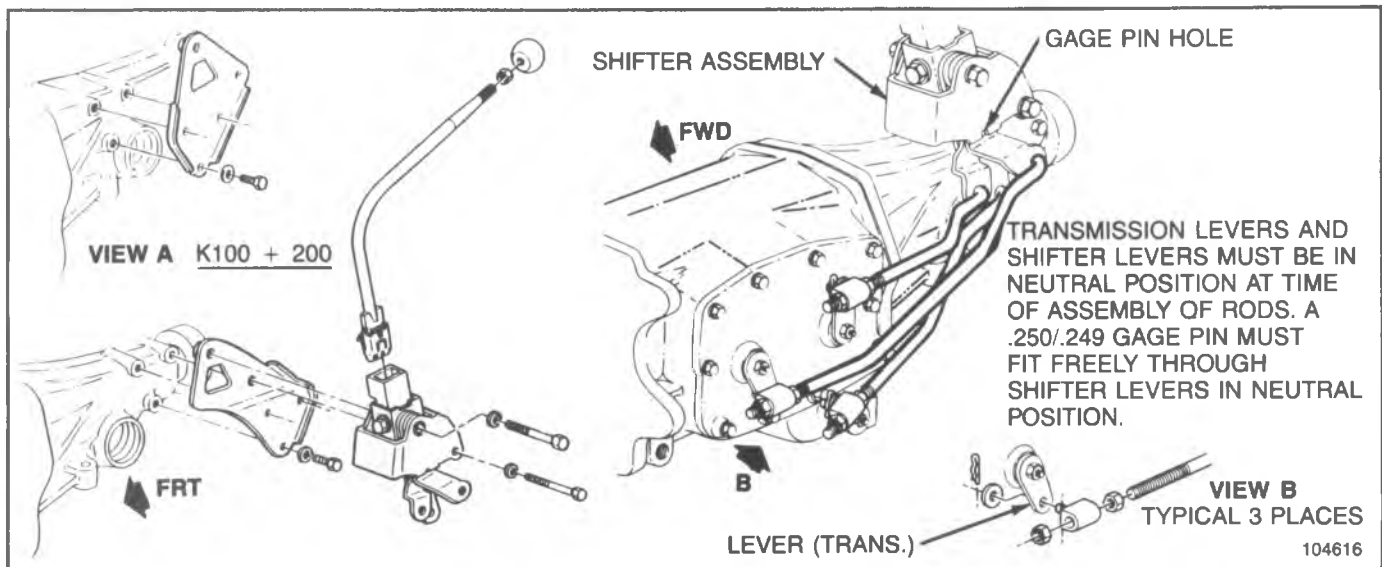

Fig. 7B-3--C-K Truck (89mm) Shift Linkage

procedure for the steering column lower bearing in Section 3B.

4. Lubricate all rod and swivel connections and recheck shift effort after installation.
5. If shift linkage is free from binding, the column levers should be checked for end play. A .005" feeler gage should fit between the levers and control lever.
6. Connect control rods and check steering column control levers for alignment. In neutral, the column control lever tangs should line up with the slot in the main control lever.

### Floor Shift Control

All swivels, rods and mountings should be checked for lost motion and repaired or replaced as necessary. Transmission control levers should be checked for wear and repaired or replaced as necessary.

## TRANSMISSION SHIFT EFFORT

### Transmission Shift Effort Checking Procedures

1. Remove the shift rods at the transmission and align the sleeve, blocker ring and gear by shifting into the offending gear and then back into neutral.
2. Check the torque required to shift into gear with an inch pound torque wrench on the shift lever attaching bolt. If more than the specified torque 5 N·m (50 in. lbs.) is required, the transmission shift lever should be checked for rust or dirt binding the lever.
3. Clean levers, lubricate and recheck the torque value.

**NOTICE:** If at this point in the procedure, it is found that high shift effort or blockout still exists, an anti-chatter lubricate (positraction additive) should be used. The lubricant is available in a plastic bottle and can be squirted in the transmission through the filler plug.

### Transmission Internal Problems Related to Shift Effort

When the above procedures have been checked and the problem still exists, the transmission will have to be removed

and disassembled for further diagnosis. There are three basic types of transmission internal problems reflected by shifting effort.

1. **Hard Shifting** - The effort to shift is excessive, but the gears engage. The lever moves with excessive effort throughout the entire travel range. If the static shift effort is high, (clutch depressed, engine not running), the synchronizer sleeve and hubs should be checked for a tight fit. With the three synchronizer keys removed, the sleeve should be loose on the hub. If the hub and sleeve are not a loose fit, replace the synchronizer assembly.
2. **Blockout** - The lever moves freely until the synchronizer is engaged. Synchronization should be heard to take place, but the gear will not engage. When it does engage, a double bump is generally felt in the lever. The synchronized blocker ring can be damaged by excessive force on gear cones that are finished improperly. The blocker ring material may stick to the synchronizer gear cone causing it to be a yellowish brass color, in streaks, which results in hard shifts when present. The gear cone should be a bright silver color. Polish the gear cone with 400 grit paper to a bright silver when this condition is present. The blocker rings should be replaced if the thread is damaged or worn.

**Clash** - Gear clash is a sound which sometimes occurs when the sleeve and gear chamfer contact each other in the unsynchronized state. The characteristics of clash are a grating or loud buzzing sound from the transmission. The shift lever load will be lower, but a vibration should be felt. The noise (clash) can be for a short instant or long enough to keep the gear from being engaged. This condition should not be confused with hard shifting or reported as such. Hard shifting and clash are directly opposite conditions. When the clash is slight, the load will build up on the shift lever and then fall off rapidly followed by the grating sound.

If the transmission has been clashing, the sleeve ends should be examined for chipping and burrs. If the sleeves are damaged, the synchronizer assemblies and blocker rings should be replaced. Synchronizer sleeve ends should have an angular surface. The surfaces should be even from side to side and the radii indicated should be very small. Any chipping will require synchronizer replacement.

Check the synchronizer load. When the keys are installed, the spring ends on one side of the hub should be hooked in one key and the spring on the opposite side of the synchronizer should not be hooked on the same key. A definite load should be felt when the sleeve is moved on the hubs with the keys and springs in proper position.

## TRANSMISSION ALIGNMENT

In some instances where excessive gear whine or high speed gear hop out, particularly at 50 mph (80 km/h) and up, are encountered, and after all other probable causes have been checked, an alignment check of the transmission and clutch housing may be helpful.

A special tool, on which a dial indicator is mounted, is necessary to check the transmission case rear bore alignment. This tool may be made from a new or good used clutch gear which has a good bearing surface on the crankshaft pilot end and at the front main bearing location.

The splines on the clutch gear shaft and the teeth on the clutch gear should be ground off so the shaft may be rotated in a clutch disc hub without interference when assembled in the car. Weld a piece of 6.3mm (1/4 in.) rod in the mainshaft pilot bore long enough to extend out the case rear bore. Assemble a good bearing on the clutch gear shaft and secure it with the clutch gear bearing snap ring. Attach a suitable dial indicator to the rod.

1. Remove the transmission from the vehicle and completely disassemble, except for the reverse idler gear. In any case where the clutch gear pilot or pilot bearing is excessively loose or worn, the pilot bearing should be replaced before checking the transmission case rear bore alignment by the dial indicator method.
2. Carefully install the special tool with the dial indicator in the transmission case with the face of the indicator to the rear of the case and with the tracing finger contacting the I.D. of the case rear bore. Secure in place with a clutch gear bearing retainer.

3. Assemble the transmission case to the clutch housing and tighten the four transmission mounting bolts securely. Be sure to clean off any paint or other foreign material on the mating faces of the clutch housing and transmission as any foreign material on these faces will change alignment; also, check carefully for dings or burrs on these mating surfaces and remove carefully as necessary.
4. Dial indicate the transmission case rear bore and record the indicator readings in the 12, 3, 6 and 9 o'clock positions. It is best to start the reading at the 3, 6, 9 or 12 o'clock position closest to the point where the indicator plunger reaches its maximum outward travel. Set the dial indicator at "0" at this location and then record the 3, 6, 9 and 12 o'clock readings in rotation.
5. Install temporary slotted shims between the transmission case and the clutch housing in the quantities and at the bolt locations as necessary to bring misalignment at the transmission case rear bore to a maximum of .127mm (0.005 in.) indicator reading in either the vertical or horizontal direction. **EXAMPLE:** If the maximum indicator reading is at the 12 o'clock position, put shims on the two bottom bolts.
6. After the position and quantity of shims has been determined and recorded, the transmission case may be removed.

**NOTICE:** The clutch housing should then be stamped, showing the position where shims are to be installed and the thickness of shims at each location.

7. Inspect the external clutching teeth of the clutch gear and second speed gear. Inspect the second and third speed clutch internal clutching teeth. If the teeth are worn or tapered, even slightly, the gears should be replaced. Reassemble the transmission.
8. Install the transmission assembly to the clutch housing, using the correct number of shims at the proper locations as previously determined. Shims are available by unit part number with each unit consisting of the following shims:
  - 4--.002" shims identification--two corners cut off.
  - 2--.005" shims identification--one corner cut off.
  - 1--.010" shims identification--all corners square.

These special shims have a tab on one end for ease of installation. Do not slot the shims for the permanent installation.

## MANUAL TRANSMISSION DIAGNOSIS

| CONDITION                            | PROBABLE CAUSE   | CORRECTION   |
|--------------------------------------|--|--|
| Slips out of High Gear               | <ul style="list-style-type: none"> <li>a. Transmission loose on clutch housing</li> <li>b. Shift rods interfere with engine mounts or clutch throw-out lever</li> <li>c. Shift linkage does not work freely; binds</li> <li>d. Damaged mainshaft pilot bearing</li> <li>e. Main drive gear retainer broken or loose</li> <li>f. Dirt between transmission case and clutch housing</li> <li>g. Misalignment of transmission</li> <li>h. Stiff shift lever seal</li> <li>i. Pilot bearing loose in crankshaft</li> <li>j. Worn or improperly adjusted linkage</li> </ul> | <ul style="list-style-type: none"> <li>a. Tighten mounting bolts</li> <li>b. Replace or bend levers and rods to eliminate interference</li> <li>c. Adjust and free up shift linkage</li> <li>d. Replace pilot bearing</li> <li>e. Tighten or replace main drive gear</li> <li>f. Clean mating surfaces</li> <li>g. Refer to TRANSMISSION ALIGNMENT</li> <li>h. Replace seal</li> <li>i. See Section 6 for brg. fits</li> <li>j. Adjust or replace linkage as required</li> </ul> |
| Noisy in All Gears                   | <ul style="list-style-type: none"> <li>a. Insufficient lubricant</li> <li>b. Worn countergear bearings</li> <li>c. Worn or damaged main drive gear and countergear</li> <li>d. Damaged main drive gear or main shaft bearings</li> <li>e. Worn or damaged countergear anti-lash plate</li> </ul>   | <ul style="list-style-type: none"> <li>a. Fill to correct level</li> <li>b. Replace countergear bearings and shaft</li> <li>c. Replace worn or damaged gears</li> <li>d. Replace damaged bearings or main drive gear</li> <li>e. Replace countergear</li> </ul>  |
| Noisy in High Gear                   | <ul style="list-style-type: none"> <li>a. Damaged main drive gear bearing</li> <li>b. Damaged mainshaft bearing</li> <li>c. Damaged high speed gear synchronizer</li> </ul>  | <ul style="list-style-type: none"> <li>a. Replace damaged bearing</li> <li>b. Replace damaged bearing</li> <li>c. Replace synchronizer</li> </ul>  |
| Noisy in Neutral with Engine Running | <ul style="list-style-type: none"> <li>a. Damaged main drive gear bearing</li> <li>b. Damaged or loose mainshaft pilot bearing</li> <li>c. Worn or damaged countergear anti-lash plate</li> <li>d. Worn countergear bearings</li> </ul>  | <ul style="list-style-type: none"> <li>a. Replace damaged bearing</li> <li>b. Replace pilot bearings. See Section 6 for bearing fits</li> <li>c. Replace countergear</li> <li>d. Replace countergear bearings and shaft</li> </ul>   |
| Noisy in all Reduction Gears         | <ul style="list-style-type: none"> <li>a. Insufficient lubricant</li> <li>b. Worn or damaged main drive gear or countergear</li> </ul>   | <ul style="list-style-type: none"> <li>a. Fill to correct level</li> <li>b. Replace faulty or damaged gears</li> </ul>   |
| Noisy in Second Only                 | <ul style="list-style-type: none"> <li>a. Damaged or worn second-speed constant mesh gears</li> <li>b. Worn or damaged countergear rear bearings</li> <li>c. Damaged or worn second-speed synchronizer</li> </ul>  | <ul style="list-style-type: none"> <li>a. Replace damaged gears</li> <li>b. Replace countergear bearings and shaft</li> <li>c. Replace synchronizer</li> </ul>   |
| Noisy in Third Only (Four Speed)     | <ul style="list-style-type: none"> <li>a. Damaged or worn third-speed constant mesh gears</li> <li>b. Worn or damaged countergear bearings</li> </ul>  | <ul style="list-style-type: none"> <li>a. Replace damaged gears</li> <li>b. Replace damaged countergear bearings and shaft</li> </ul>  |

Fig. 7B-4--Manual Transmission Diagnosis Chart A

MANUAL TRANSMISSION DIAGNOSIS (CONT'D.)

| CONDITION  | PROBABLE CAUSE  | CORRECTION  |
|--|---|---|
| Noisy in Reverse Only  | a. Worn or damaged reverse idler gear or idler bushing<br>b. Worn or damaged reverse gear on mainshaft<br>c. Damaged or worn reverse countergear<br>d. Damaged Shift mechanism  | a. Replace reverse idler gear assembly<br>b. Replace reverse gear<br>c. Replace countergear assembly<br>d. Inspect linkage and adjust or replace damaged parts                  |
| Excessive Backlash in all Reduction Gears                        | a. Worn countergear bearings<br>b. Excessive end play in countergear  | a. Replace bearings<br>b. Replace countergear thrust washers  |
| Main Drive Gear Bearing Retainer Burned or Scored by Input Shaft | a. Loose or damaged mainshaft pilot bearing<br>b. Misalignment of transmission  | a. <b>Replace bearing. Refer to Clutch Section for bearing fit</b><br>b. Align transmission   |
| Leaks Lubricant  | a. Excessive amount of lubricant in transmission<br>b. Loose or broken main drive gear bearing retainer<br>c. Main drive gear bearing retainer gasket damaged<br>d. Side cover loose or gasket damaged<br>e. Rear bearing retainer oil seal leaks<br>f. Countershaft loose in case<br>g. Shift lever seals leak | a. Drain to correct level<br>b. Tighten or replace retainer<br>c. Replace gasket<br>d. Tighten cover or replace gasket<br>e. Replace seal<br>f. Replace case<br>g. Replace seal |

Fig. 7B-5--Manual Transmission Diagnosis Chart B

SHIFTING DIFFICULTY DIAGNOSIS

| CONDITION  | PROBABLE CAUSE   | CORRECTION  |
|--|--|---|
| High Shift Effort-Column Shift (Effort exceeds 2 ft. lbs. at lever knob with transmission linkage disconnected.) | Binding of column levers   | <b>Adjust column as outlined in the Steering Column Section.</b><br><br>Clean and lubricate all rod and swivel connections. |
|  | Lever end play exceeds .005 in.  | Adjust levers   |
|  | Misalignment of column control levers.   | Adjust levers   |
| Gear Clash and binding   | Improper linkage Adjustment  | Adjust Shift linkage  |
| Lost motion  | Loose or worn swivels and grommets.<br>Deflection of Mounting Brackets.<br>Loose shift levers.<br>Damaged Cordon Shaft | Replace defective parts   |

Fig. 7B-6--Shifting Difficulty Diagnosis Chart



## 3 SPEED 76MM TRANSMISSION

### CONTENTS

|                                   |   |   |    |
|-----------------------------------|---|---|----|
| On Vehicle Service .....          | 1 | Bearing Rollers .....                     | 7  |
| Transmission .....                | 1 | Gears .....                               | 7  |
| Extension Housing Oil Seal.....   | 2 | Reverse Idler Gear Bushing .....          | 7  |
| Speedometer Driven Gear .....     | 2 | Repairs .....                             | 7  |
| Side Cover .....                  | 2 | Synchronizer Keys and Spring.....         | 7  |
| Unit Repair .....                 | 5 | Extension Oil Seal and/or Bushing.....    | 7  |
| Disassembly of Transmission ..... | 5 | Drive Gear Bearing Retainer Oil Seal..... | 8  |
| Disassembly of Mainshaft .....    | 6 | Assembly of Mainshaft.....                | 8  |
| Cleaning and Inspection .....     | 6 | Assembly of Transmission.....             | 9  |
| Transmission Case .....           | 6 | Specifications .....                      | 10 |
| Front and Rear Bearings.....      | 7 | Special Tools.....                        | 10 |

### ON VEHICLE SERVICE

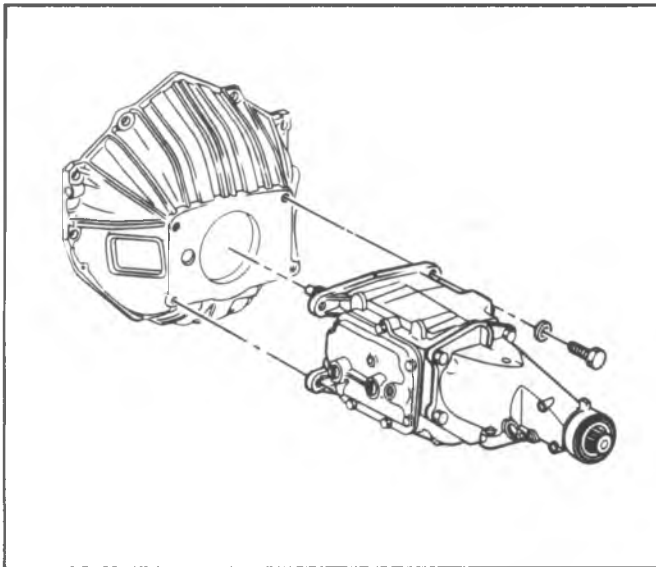

Fig. 7B1-1--Transmission To Engine Attachment

#### TRANSMISSION (Fig. 7B1-1)

##### Removal

1. Raise vehicle on suitable hoist and drain lubricant from transmission.
2. Disconnect speedometer cable.
3. Remove shift controls from transmission.
4. Disconnect parking brake lever and controls (when used) and back up lamp switch wire.
5. Disconnect propeller shaft from transmission as described in Section 4A.
6. Position a suitable dolly or jack under the vehicle and adjust to carry the weight of the transmission.
7. Visually inspect to determine if other equipment, lines or brackets must be removed to permit removal of the transmission. Remove crossmember.

**NOTICE:** Be sure to support the clutch release bearing and support assembly during removal of the transmission main drive gear from the flywheel housing. This will prevent the release bearing from

falling out of the flywheel housing when the transmission is removed.

8. Remove transmission-to-clutch housing mounting bolts.

**NOTICE:** When removing the transmission, do not allow the weight of the transmission to hang on the clutch disc hub, as the disc may become distorted, seriously affecting clutch operation.

9. Move the transmission assembly straight away from the engine, using care to keep the transmission main drive gear shaft in alignment with the clutch disc hub. Refer to Fig. 7B1-1.
10. When the transmission is free from the engine, lower the transmission and move from under the vehicle.
11. If desired, a careful check of clutch components should be made after the transmission has been removed. If the clutch requires repair, refer to Section 7C before transmission is reinstalled in the vehicle.

##### Installation

1. Apply a light coating of high temperature grease to the main drive gear bearing retainer and splined portion of transmission main drive gear shaft to assure free movement of clutch and transmission components during assembly.

**NOTICE:** Do not apply an excessive amount of grease in the above areas, as under normal operation this grease could be thrown onto clutch facing resulting in clutch problems.

2. Shift the transmission into high gear. Mount transmission on dolly or jack and move into position under the vehicle. Avoid springing the clutch when the transmission is being installed to the engine. Do not force the transmission into the clutch disc hub. Do not let the transmission hang unsupported in the splined portion of the clutch disc.
3. Align the transmission main drive gear shaft with the clutch disc hub by rotating the transmission companion flange or output yoke. Move the transmission forward, guiding the main drive gear shaft into the clutch disc splines.
4. Install transmission-to-clutch housing mounting



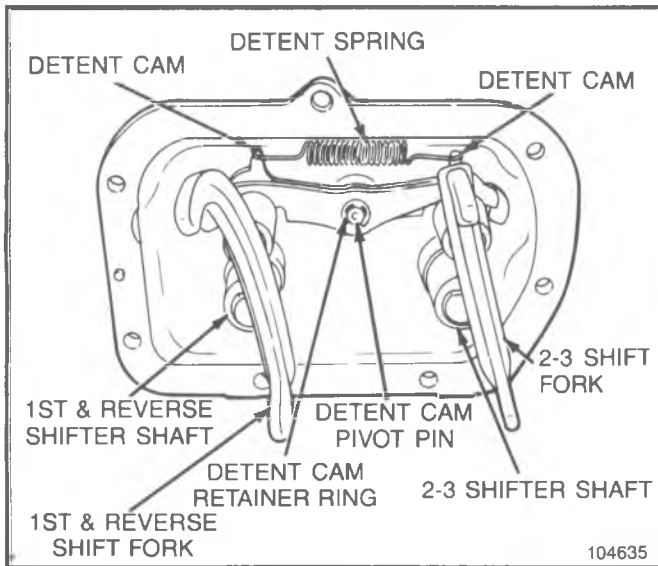

Fig. 7B1-2--Transmission Side Cover Assembly

bolts and washers. Tighten bolts to specifications.

5. Install crossmember.
6. Connect propeller shaft to transmission as described in Section 4A. Remove transmission jack.
7. Connect parking brake lever and control (if used). Adjust brakes as outlined in Section 5.
8. Reconnect speedometer cable at transmission.
9. Reinstall shift controls on transmission.
10. If other equipment (exhaust pipe, support brackets, etc.) was removed, reinstall these parts.
11. Refill transmission with lubricant recommended in Section 0B of this manual.
12. If necessary, adjust clutch or transmission control linkage to achieve proper transmission operation.
13. Lower vehicle.

## EXTENSION HOUSING OIL SEAL

### Removal

1. Raise vehicle.
2. Drain lubricant from transmission.
3. Disconnect propeller shaft from transmission as described in Section 4A.
4. Pry seal out of extension housing.

### Installation

1. Coat outer diameter of new oil seal with sealing cement. Install new oil seal using extension housing oil seal installer (J-21426 or J-21359).
2. Reconnect propeller shaft to transmission as described in Section 4A.
3. Refill transmission with lubricant recommended in Section 0B.
4. Lower vehicle.

## SPEEDOMETER DRIVEN GEAR

### Removal

1. Raise vehicle.
2. Disconnect speedometer cable, then remove lock plate to housing bolt and lock washer and remove lock plate. Insert screw driver in lock plate slot in fitting and pry fitting, gear and shaft from housing. Pry "O" ring from groove in fitting.

### Installation

1. Install new "O" ring in groove in fitting, coat "O" ring and driven gear shaft with transmission lubricant and insert shaft.
2. Hold the assembly so slot in fitting is toward lock plate boss on housing and install in housing. Push fitting into housing until lock plate can be inserted in groove and attached to housing. Connect speedometer cable.
3. Lower vehicle.

## SIDE COVER (Fig. 7B1-2)

### Removal

1. Raise vehicle.
2. Disconnect control rods from levers and back-up lamp wiring.
3. Shift transmission into neutral detent positions before removing cover. Remove cover assembly from transmission case carefully and allow oil to drain.
4. Remove the outer shifter levers.
5. Remove both shift forks from shifter shaft assemblies. Remove both shifter shaft assemblies from cover. Seals around shifter shaft may now be pried out if replacement is required because of damage.
6. Remove detent cam spring and pivot retainer "C" ring. Remove both detent cams.

### Installation

1. With detent spring tang projecting up over the 2nd and 3rd shifter shaft cover opening, install the first and reverse detent cam onto the detent cam pivot pin. With the detent spring tang projecting up over the first and reverse shifter shaft cover hole install the 2nd and 3rd detent cam.
2. Install detent cam retaining "C" ring to pivot shaft, and hook spring into detent cam notches.
3. Install both shift shaft assemblies in cover being careful not to damage seals. Install both shift forks to shifter shaft assemblies, lifting up on detent cam to allow forks to fully seat into position.
4. Install outer shifter levers, flat washers, lock washers and bolts.
5. Shift shifter levers into neutral detent (center) position and slide cover into place making sure the shift forks are aligned with their respective mainshaft clutch sliding sleeves.
6. Install cover attaching bolts and tighten evenly to specified torque, then connect wiring.
7. Remove filler plug and add lubricant specified in Section 0B to level of filler plug hole.
8. Lower vehicle.

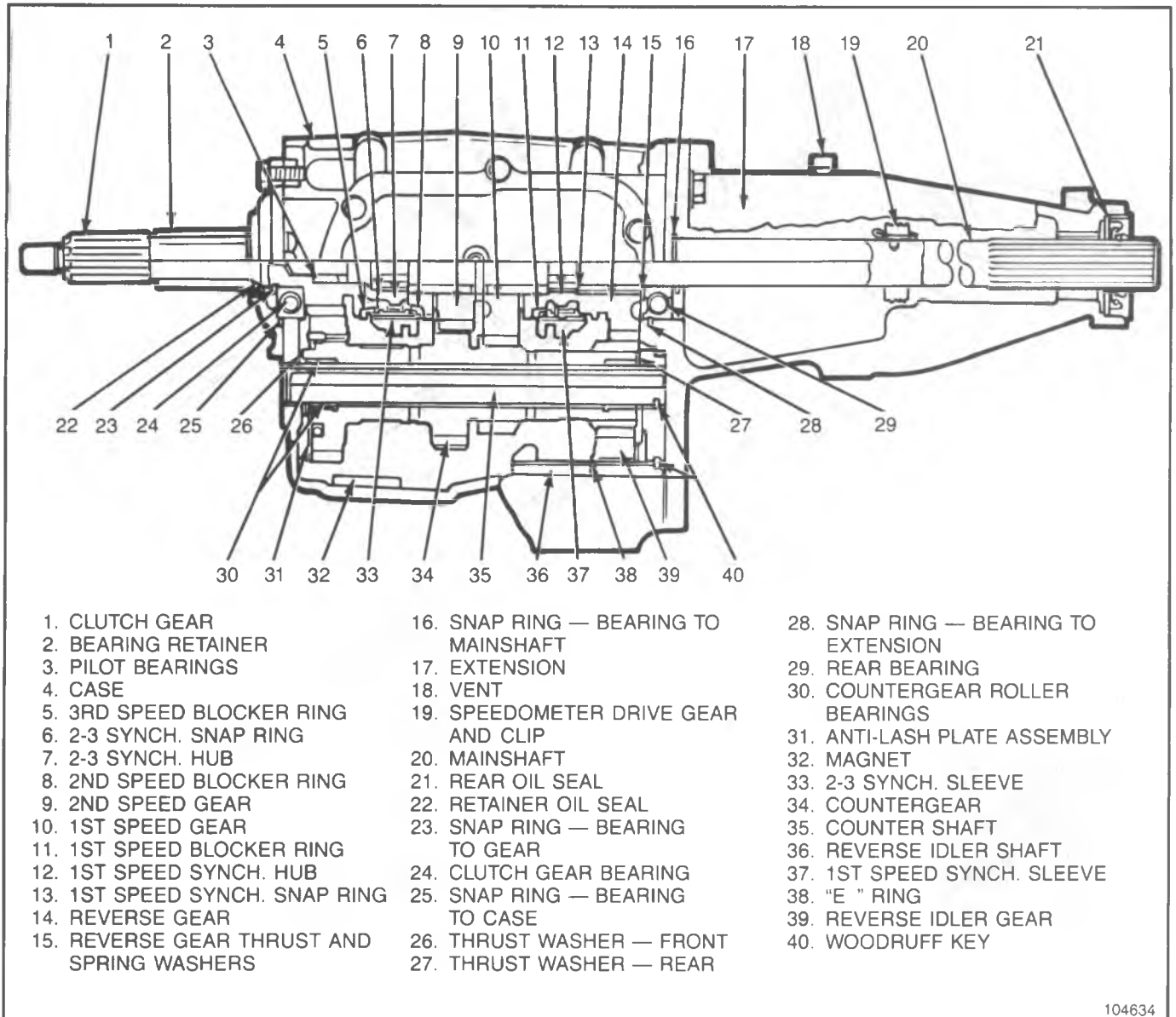
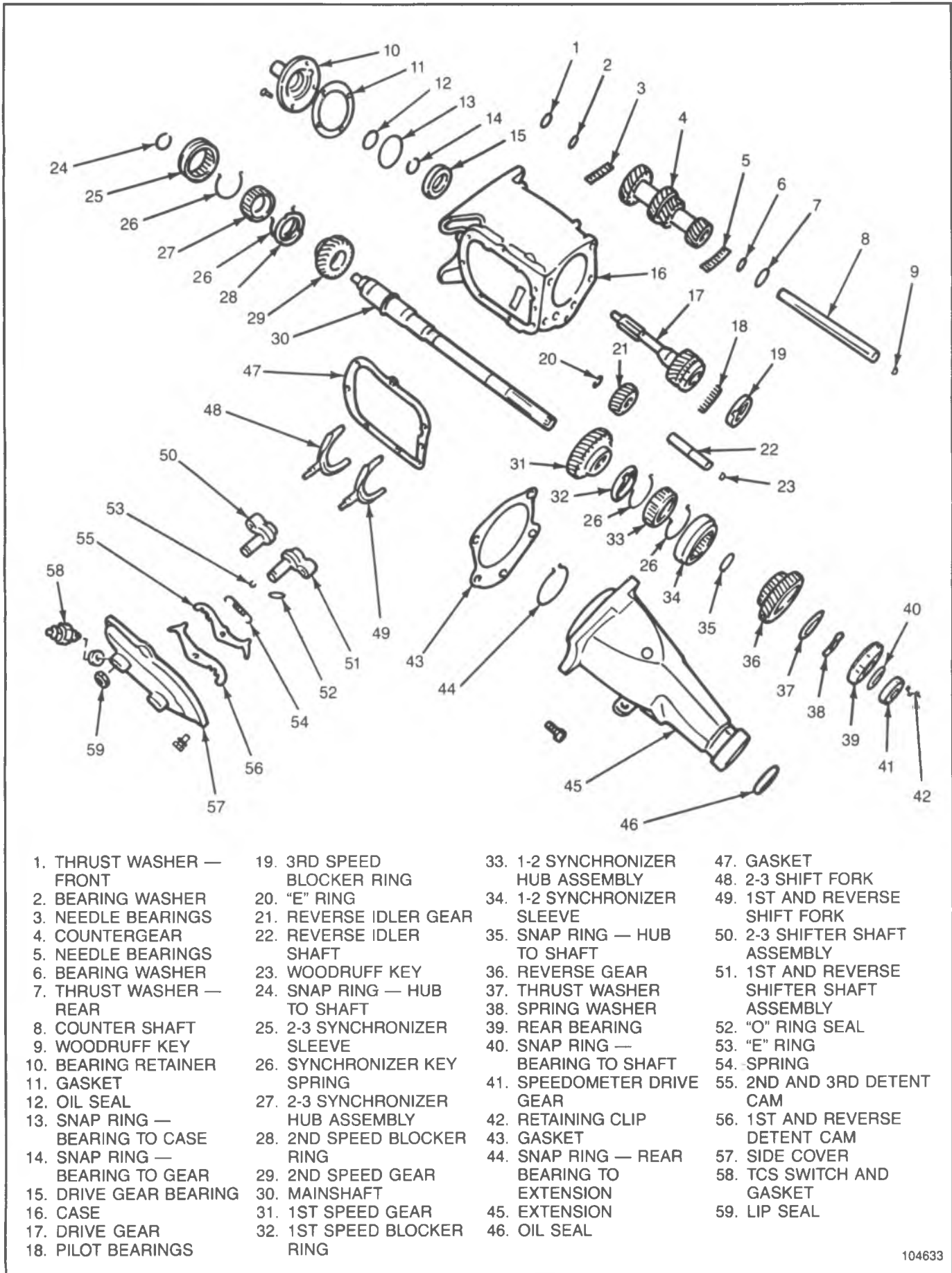

Fig. 7B1-3--3 Speed 76mm Cross Section



- |                                 |                                   |   |  |
|---------------------------------|-----------------------------------|---|--|
| 1. THRUST WASHER — FRONT        | 19. 3RD SPEED BLOCKER RING        | 33. 1-2 SYNCHRONIZER HUB ASSEMBLY         | 47. GASKET                                 |
| 2. BEARING WASHER               | 20. "E" RING                      | 34. 1-2 SYNCHRONIZER SLEEVE               | 48. 2-3 SHIFT FORK                         |
| 3. NEEDLE BEARINGS              | 21. REVERSE IDLER GEAR            | 35. SNAP RING — HUB TO SHAFT              | 49. 1ST AND REVERSE SHIFT FORK             |
| 4. COUNTERGEAR                  | 22. REVERSE IDLER SHAFT           | 36. REVERSE GEAR                          | 50. 2-3 SHIFTER SHAFT ASSEMBLY             |
| 5. NEEDLE BEARINGS              | 23. WOODRUFF KEY                  | 37. THRUST WASHER                         | 51. 1ST AND REVERSE SHIFTER SHAFT ASSEMBLY |
| 6. BEARING WASHER               | 24. SNAP RING — HUB TO SHAFT      | 38. SPRING WASHER                         | 52. "O" RING SEAL                          |
| 7. THRUST WASHER — REAR         | 25. 2-3 SYNCHRONIZER SLEEVE       | 39. REAR BEARING                          | 53. "E" RING                               |
| 8. COUNTER SHAFT                | 26. SYNCHRONIZER KEY SPRING       | 40. SNAP RING — BEARING TO SHAFT          | 54. SPRING                                 |
| 9. WOODRUFF KEY                 | 27. 2-3 SYNCHRONIZER HUB ASSEMBLY | 41. SPEEDOMETER DRIVE GEAR                | 55. 2ND AND 3RD DETENT CAM                 |
| 10. BEARING RETAINER            | 28. 2ND SPEED BLOCKER RING        | 42. RETAINING CLIP                        | 56. 1ST AND REVERSE DETENT CAM             |
| 11. GASKET                      | 29. 2ND SPEED GEAR                | 43. GASKET                                | 57. SIDE COVER                             |
| 12. OIL SEAL                    | 30. MAINSHAFT                     | 44. SNAP RING — REAR BEARING TO EXTENSION | 58. TCS SWITCH AND GASKET                  |
| 13. SNAP RING — BEARING TO CASE | 31. 1ST SPEED GEAR                | 45. EXTENSION                             | 59. LIP SEAL                               |
| 14. SNAP RING — BEARING TO GEAR | 32. 1ST SPEED BLOCKER RING        | 46. OIL SEAL                              |  |
| 15. DRIVE GEAR BEARING          |                                   |   |  |
| 16. CASE                        |                                   |   |  |
| 17. DRIVE GEAR                  |                                   |   |  |
| 18. PILOT BEARINGS              |                                   |   |  |

Fig. 7B1-4-3-Speed 76mm Exploded View

## UNIT REPAIR

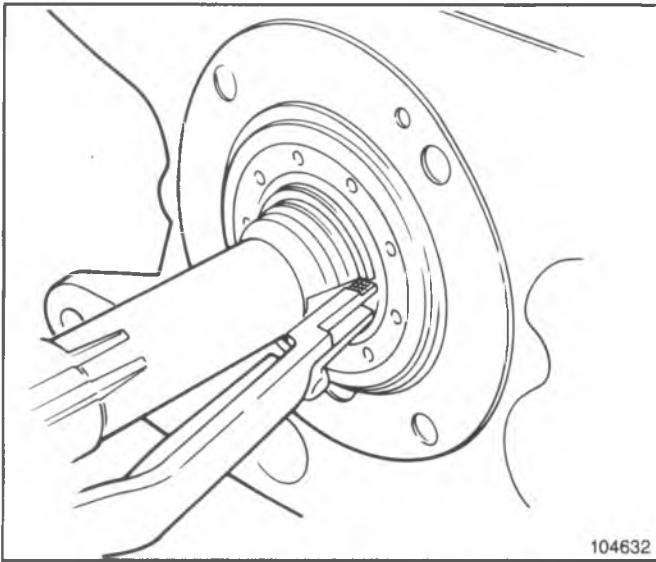

Fig. 7B-5--Clutch Gear Bearing Retaining Ring

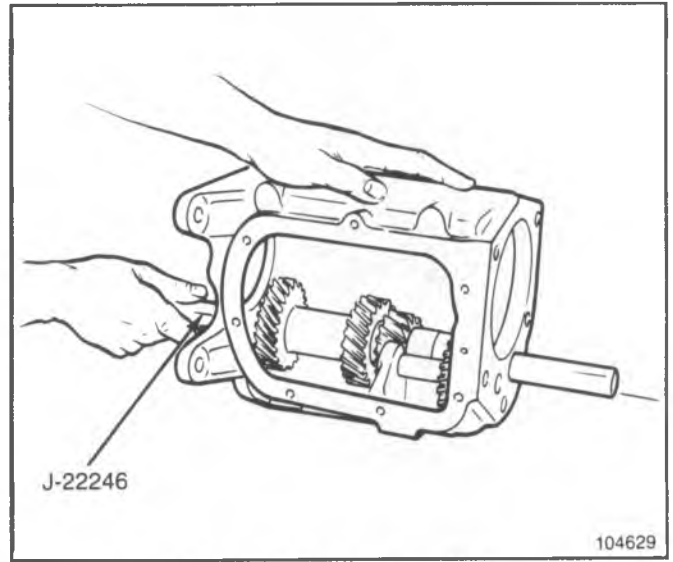

Fig. 7B1-8--Counter Gear Shaft

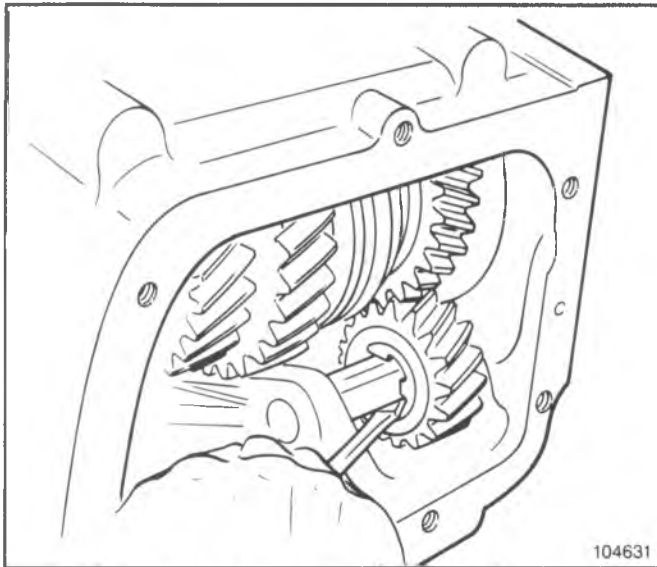

Fig. 7B1-6--Reverse Idler Shaft "E" Ring

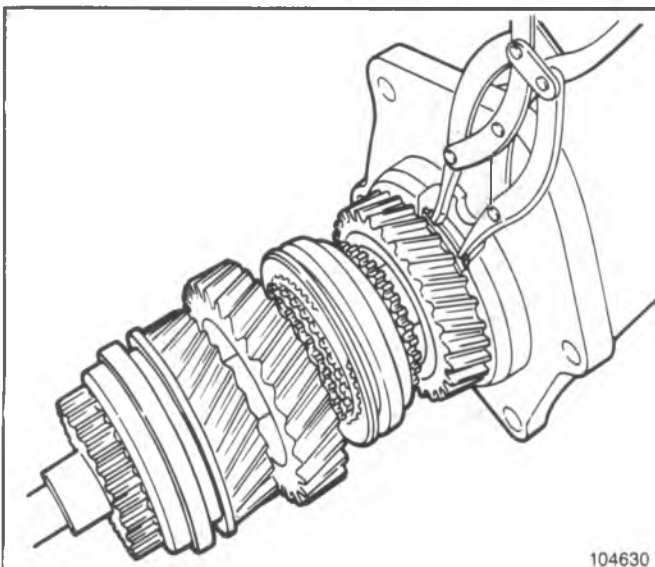

Fig. 7B1-7--Rear Extension From Main Shaft

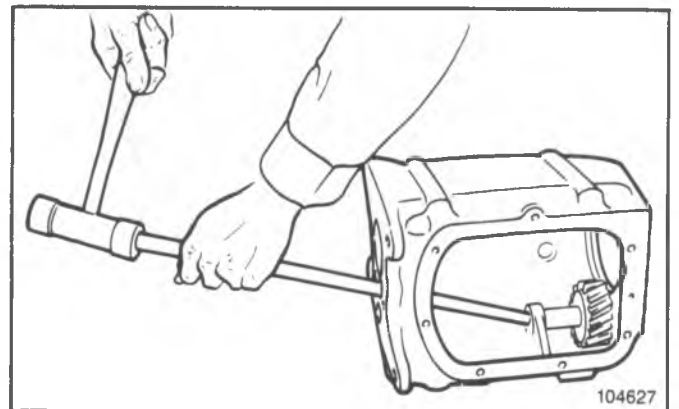

Fig. 7B1-9--Reverse Idler Shaft

### TRANSMISSION

#### Disassembly (Fig. 7B1-4)

1. Remove side cover attaching bolts and side cover assembly.
2. Remove drive gear bearing retainer and gasket.
3. Remove drive gear bearing-to-gear stem snap ring, then remove clutch gear bearing by pulling outward on clutch gear until a screwdriver or other suitable tool can be inserted between bearing large snap ring and case to complete removal (Fig. 7B1-5). The clutch gear bearing is a slip fit on the gear and into the case bore. (This provides clearance for removal of clutch gear and mainshaft assembly).
4. Remove speedometer driven gear from extension.
5. Remove extension to case attaching bolts.
6. Remove the reverse idler shaft "E" ring (Fig. 7B1-6).
7. Remove drive gear, mainshaft and extension assembly together through the rear case opening. Remove drive gear, needle bearings and synchronizer ring from mainshaft assembly.

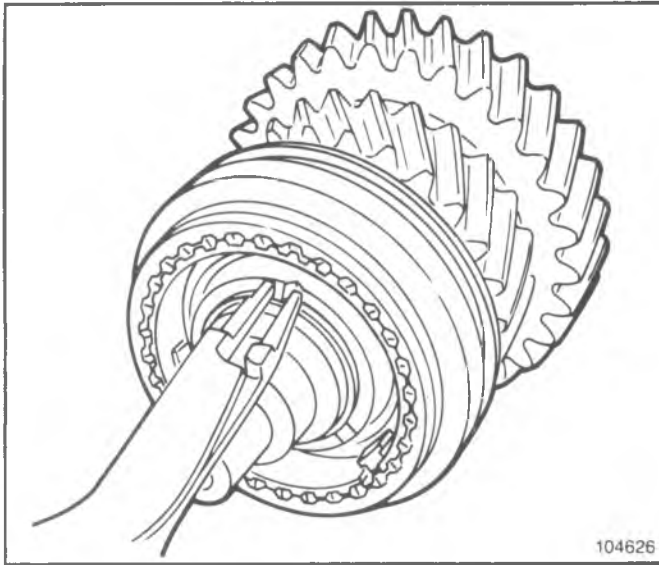

Fig. 7B1-10--2nd-3rd Clutch Hub Retaining Ring

8. Using snap ring pliers, expand the snap ring in the extension which retains the mainshaft rear bearing (Fig. 7B1-7) and remove the extension.
9. Using J-22246 at the front of the countershaft, drive the shaft and its woodruff key out the rear of the case (Fig. 7B1-8). Tool J-22246 will now hold the roller bearings in position within the countergear bore. Remove the gear, bearings and thrust washers.
10. Use a long drift or punch through the front bearing case bore and drive the reverse idler shaft and woodruff key through the rear of the case (Fig. 7B1-9).

## MAINSHAFT

### Disassembly

1. Using snap ring pliers, remove the 2nd and 3rd speed sliding clutch hub snap ring from mainshaft and remove clutch assembly, second speed blocker ring and

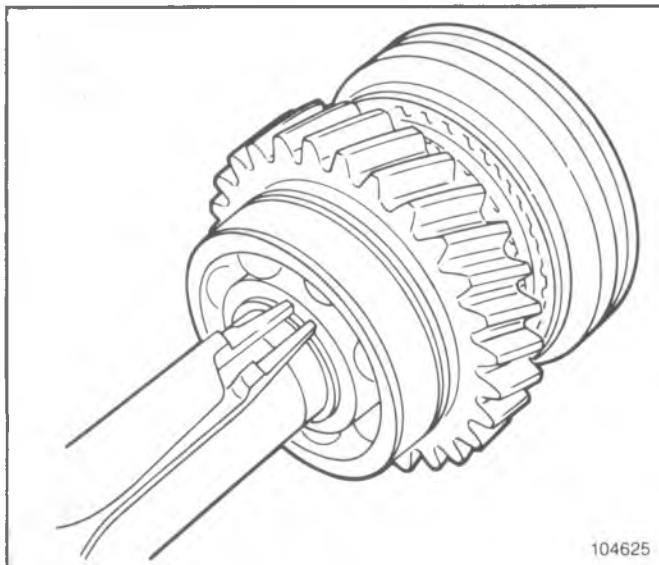

Fig. 7B1-11--Rear Bearing Retaining Ring

second speed gear from front of mainshaft. See Fig. 7B1-10.

2. Depress speedometer retaining clip and slide or tap gear from mainshaft.
3. Remove rear bearing snap ring from mainshaft groove. See Fig. 7B1-11.
4. Support reverse gear with press plates and press on rear of mainshaft to remove reverse gear, thrust washer, spring washer, rear bearing, and snap ring from rear of mainshaft. See Fig. 7B1-12.
5. Remove the 1st and Reverse sliding clutch hub snap ring from the mainshaft and remove the clutch assembly, 1st speed blocker ring and first speed gear from rear of the mainshaft.

Under certain tolerance conditions, it may be necessary to press the synchronizer hub and gear from the mainshaft.

## CLEANING AND INSPECTION

### Transmission Case

1. Wash the transmission thoroughly inside and outside with cleaning solvent, then inspect the case for cracks.
2. Check the front and rear faces for burrs, and if present, dress them off with a fine mill file.
3. Check bearing bores in case and, if damaged, replace case.

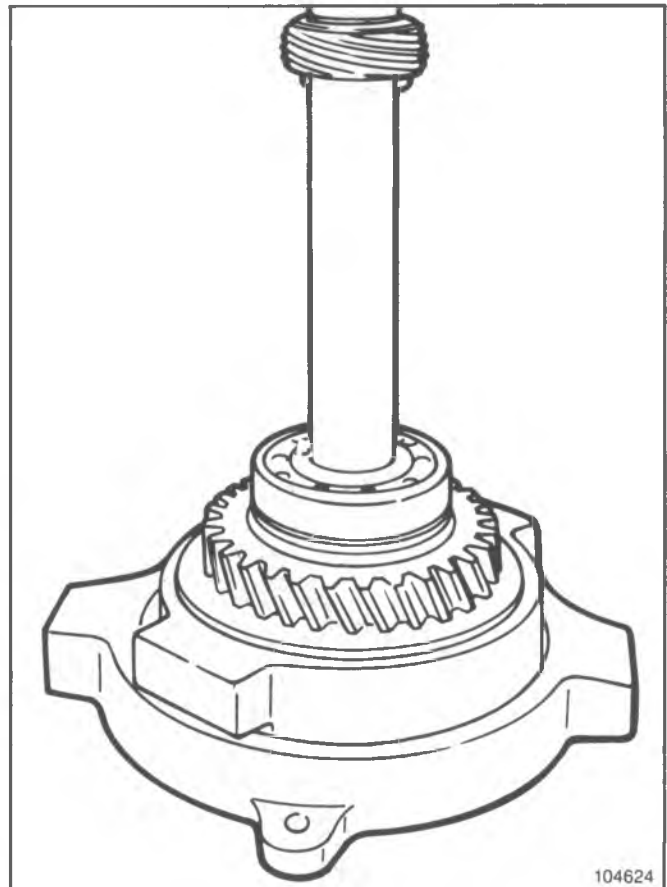

Fig. 7B1-12--Rear Bearing From Mainshaft

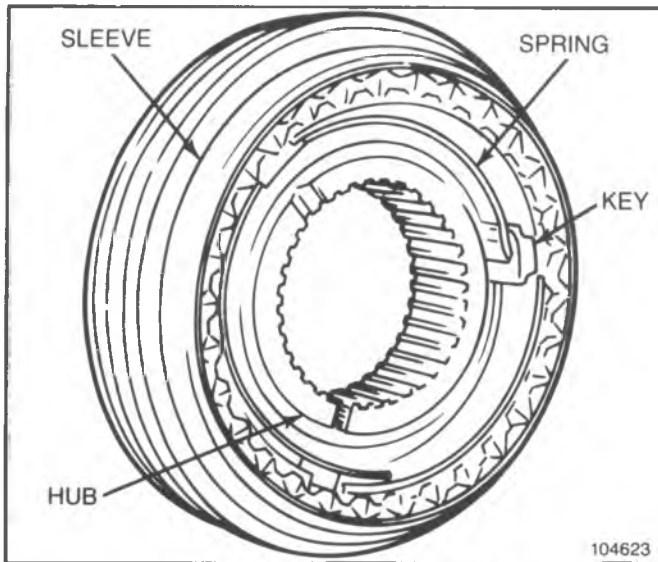

Fig. 7B1-13--Synchronizer Assembly

### Front and Rear Bearings

1. Wash the front and rear ball bearings thoroughly in a cleaning solvent.
2. Blow out bearings with compressed air.

**NOTICE:** Do not allow the bearings to spin, turn them slowly by hand. Spinning bearings may damage the race and balls.

3. Make sure bearings are clean, then lubricate with light engine oil and check them for roughness by slowly turning the race by hand.

### Bearing Rollers

All clutch gear and counter gear bearing rollers should be inspected closely and replace if they show wear. Inspect counter shaft and reverse idler shaft at the same time, replace if necessary. Replace all worn washers.

### Gears

1. Inspect all gears for excessive wear, chips or cracks and replace any that are worn or damaged.

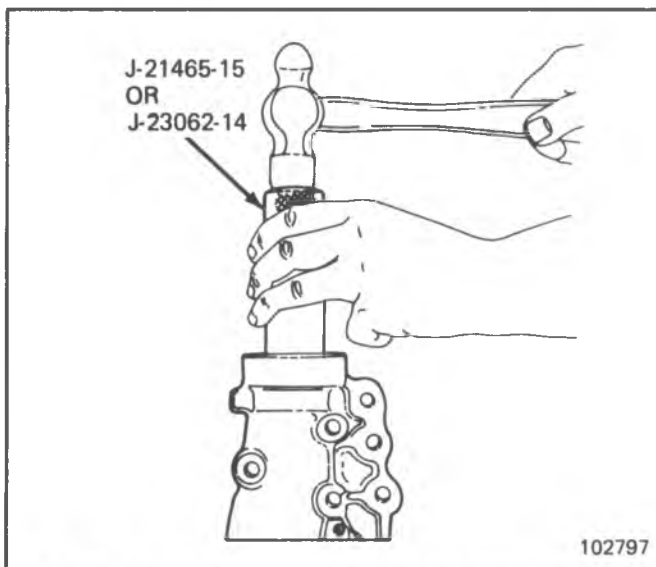

Fig. 7B1-14--Removing/Installing Rear Extension Bushing

2. Inspect reverse gear bushing and if worn or damaged, replace the entire gear. Reverse gear bushing is not serviced separately.
3. Check both clutch sleeves to see that they slide freely on their hubs.

### Reverse Idler Gear Bushing

The bushing used in the idler gear is pressed into the gear and finished bored in place. This insures the positive alignment of the bushing and shaft as well as proper meshing of the gears. Because of the high degree of accuracy to which these parts are machined, the bushing is not serviced separately.

### REPAIRS

#### Clutch Keys and Springs

##### Replacement

The clutch hubs and sliding sleeves are a selected assembly and should be kept together as originally assembled, but the keys and two springs may be replaced if worn or broken.

1. Mark hub and sleeve so that they can be matched upon reassembly.
2. Push the hub from the sliding sleeve, the keys and the springs may be easily removed.
3. Place the three keys and two springs in position (one on each side of hub) so all three keys are engaged by both springs (Fig. 7B1-13). The tanged end of each synchronizer spring should be installed into different key cavities on either side. Slide the sleeve onto the hub aligning the marks made before disassembly.

A groove around the outside of the synchronizer hub identifies the end that must be opposite the fork slot in the sleeve when assembled. This groove indicates the end of the hub with a greater recess depth.

### Extension Oil Seal or Bushing

If bushing in rear of extension requires replacement, remove seal and use Tool J-21465-15 or J-23062-14 to drive bushing into extension housing (Fig. 7B1-14). Using the same tool, drive new bushing in from the rear. Coat I.D. of bushing and seal with transmission lubricant, then install new oil seal using Tool J-21426 or J-21359 (Fig. 7B1-15).

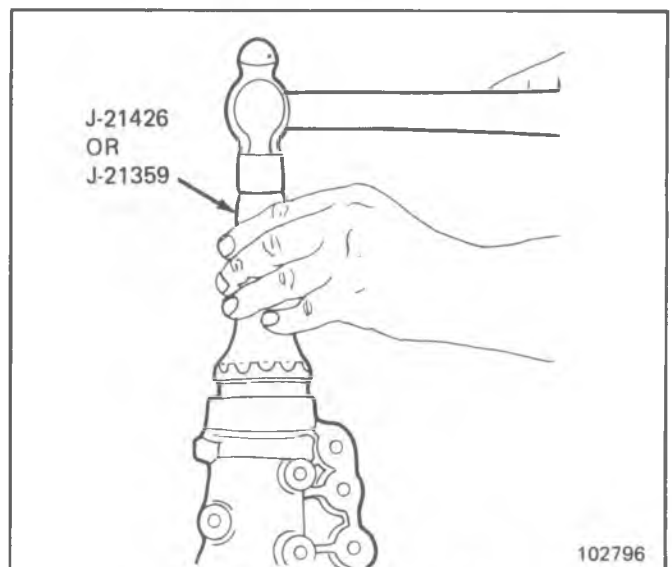

Fig. 7B1-15--Rear Extension Seal

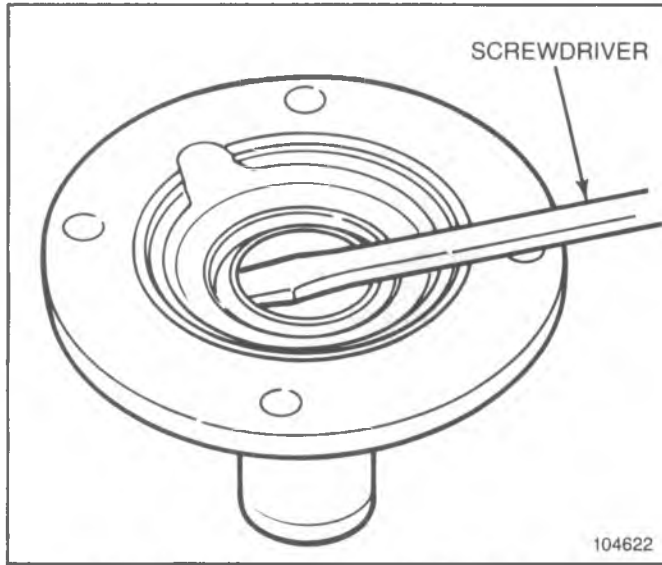

Fig. 7B1-16--Drive Gear Bearing Retainer Seal

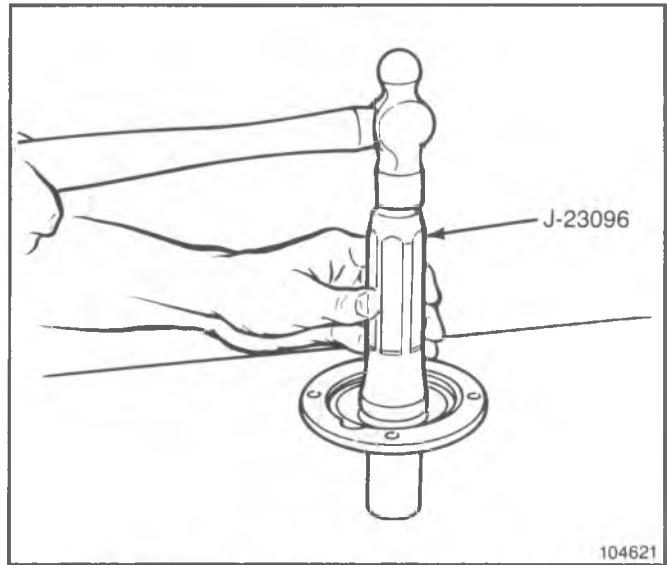

Fig. 7B1-17--Drive Gear Bearing Retainer Seal

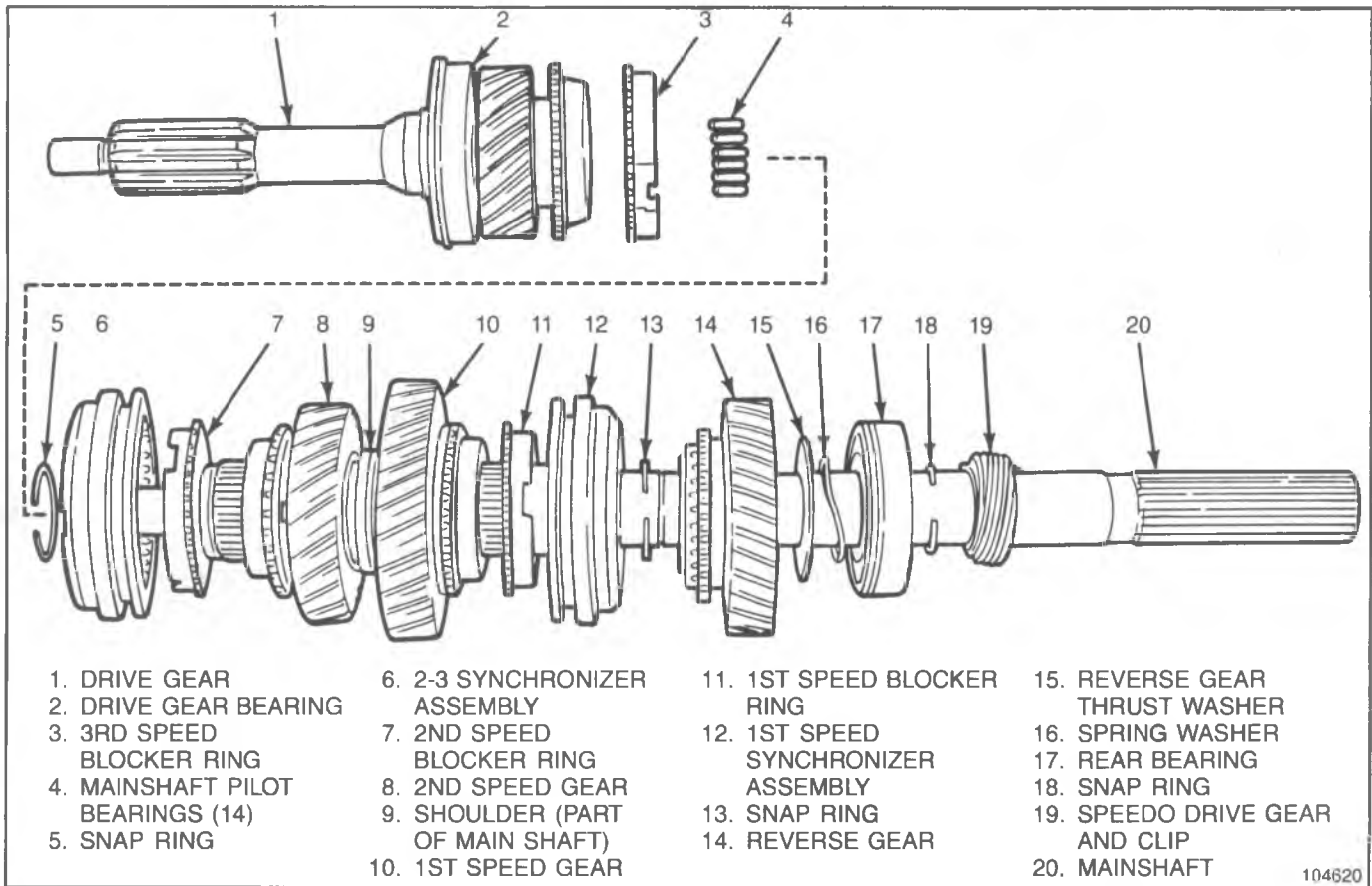

Fig. 7B1-18--Drive Gear And Mainshaft Assembly

### Drive Bearing Retainer Oil Seal

If the lip seal in the retainer needs replacement; pry the old seal out (Fig. 7B1-16) and replace with a new seal using Installer Tool J-23096, or similar tool, until seal seats in its bore (Fig. 7B1-17).

### MAINSHAFT

#### Assembly (Fig. 7B1-18)

Turn the front of the mainshaft upward. Install the following components of the mainshaft:

1. Install the second speed gear with clutching teeth upward; the rear face of the gear will butt against the flange on the mainshaft.
2. Install a blocking ring with clutching teeth downward over the synchronizing surface of the second



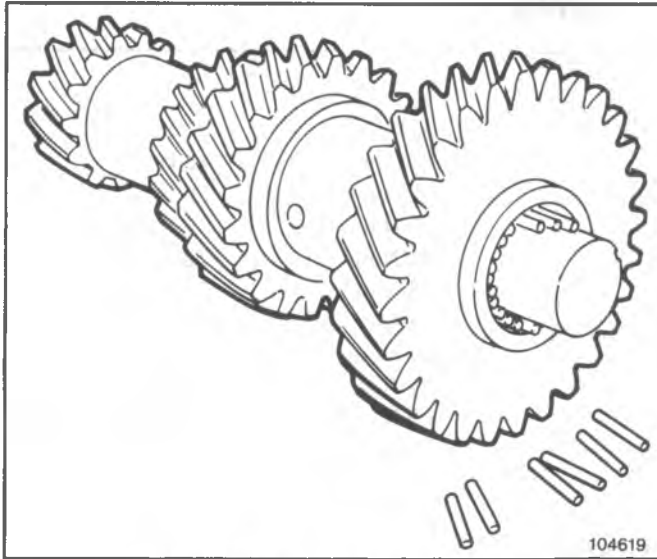

Fig. 7B1-19--Loading Countergear

speed gear. All three blocker rings used in this transmission are identical.

3. Install the second and third synchronizer assembly with the fork slot downward; press it onto splines on the mainshaft until it bottoms out. Both synchronizer assemblies used in this transmission are identical. (If sleeve becomes removed from 2-3 hub; notches on hub O.D. face forward end of mainshaft). Be sure the notches of the blocker ring align with the keys of the synchronizer assembly.
4. Install snap ring retaining synchronizer hub to mainshaft. Both synchronizer snap rings are identical. Turn the rear of the mainshaft upward. Install the following components on the mainshaft.
5. Install the first speed gear with clutching teeth upward; the front face of the gear will butt against the flange on the mainshaft.
6. Install a blocker ring with clutching teeth downward over synchronizing surface of the first speed gear.
7. Install the first and reverse synchronizer assembly with fork slot downward; push it onto splines on the mainshaft.
8. Install synchronizer hub to mainshaft snap ring. Be sure the notches of the blocker ring align with the keys of the synchronizer assembly.
9. Install reverse gear with clutching teeth downward.
10. Install reverse gear thrust washer (steel).
11. Install reverse gear spring washer.
12. Install rear ball bearing with snap ring slot downward; press onto mainshaft.
13. Install rear bearing to mainshaft snap ring.
14. Install speedometer drive gear and retaining clip.

### TRANSMISSION (Fig. 7B1-4)

#### Assembly

1. Using Tool J-22246 load a row of roller bearings (27) and a bearing thrust washer at each end of the countergear. Use heavy grease to hold them in place (Fig. 7B1-19).

2. Place countergear assembly through case rear opening along with a tanged thrust washer (tang away from gear) at each end and install countergear shaft and woodruff key from rear of case. Be sure countershaft picks up both thrust washers and that the tangs are aligned with their notches in the case.
3. Install reverse idler gear and shaft with its woodruff key from the rear of case. Do not install idler shaft "E" ring yet.
4. Using snap ring pliers, expand the snap ring in the extension and assemble extension over rear of mainshaft and onto rear bearing. Seat snap ring in rear bearing groove (Fig. 7B1-7).
5. Load the mainshaft pilot bearing (14) into the clutch gear cavity and assemble the 3rd speed blocker ring onto the clutch gear clutching surface with its teeth toward the gear.
6. Pilot the clutch gear, pilot bearings and 3rd speed blocker ring assembly over the front of the mainshaft assembly. Do not assemble bearing to gear yet. Be sure the notches in the blocker ring align with the keys in the 2-3 synchronizer assembly.
7. Place extension to case gasket at rear of case holding in place with grease and, from the rear of case, assemble the clutch gear, mainshaft and extension to case as an assembly.
8. Install extension to case retaining bolts.
9. Install front bearing outer snap ring to bearing and position bearing over stem of clutch gear and into front case bore.
10. Install snap ring to clutch gear stem, and clutch gear bearing retainer and gasket to case. The retainer oil return hole should be at the bottom.
11. Install reverse idler gear retainer "E" ring to shaft.
12. Shift synchronizer sleeves to neutral positions and install cover, gasket and fork assembly to case. Be sure forks align with their synchronizer sleeve grooves.
13. Install speedometer driven gear in extension.
14. Tighten all bolts to specified torque.
15. Rotate clutch gear shaft and shift transmission to free rotation in all gears.

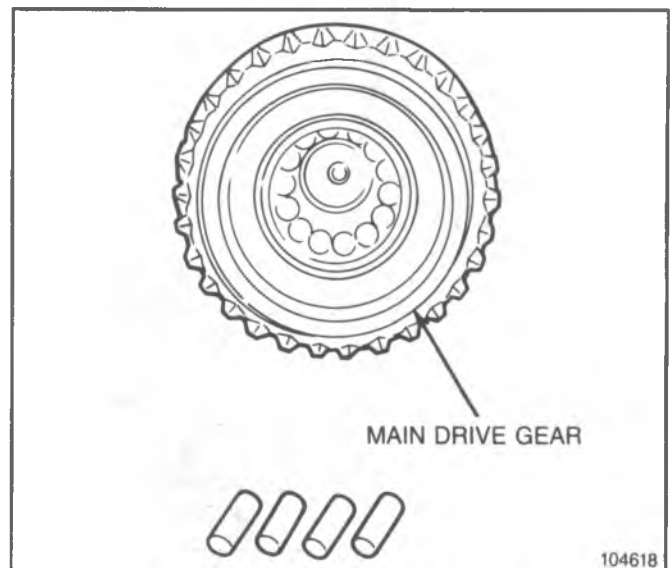

Fig. 7B1-20--Loading Pilot Bearings



## SPECIFICATIONS

|  |         |            |
|--|---------|------------|
| Drive Gear Retainer to Case Bolts          | 20 N-m  | 15 ft. lb. |
| Side Cover to Case Bolts                   | 20 N-m  | 15 ft. lb. |
| Extension to Case Bolts                    | 61 N-m  | 45 ft. lb. |
| Shift Lever to Shifter Shaft Bolts         | 32 N-m  | 25 ft. lb. |
| Lubrication Filler Plug                    | 17 N-m  | 13 ft. lb. |
| Transmission Case to Clutch Housing Bolts  | 101 N-m | 75 ft. lb. |
| Crossmember to Frame Bolts                 | 75 N-m  | 55 ft. lb. |
| Crossmember to Mount Bolts                 | 54 N-m  | 40 ft. lb. |
| 2-3 Cross Over Shaft Bracket Retaining Nut | 24 N-m  | 18 ft. lb. |
| 1 - Rev. Swivel Attaching Bolts            | 27 N-m  | 20 ft. lb. |
| Mount to Transmission Bolt                 | 55 N-m  | 40 ft. lb. |

102707

## SPECIAL TOOLS

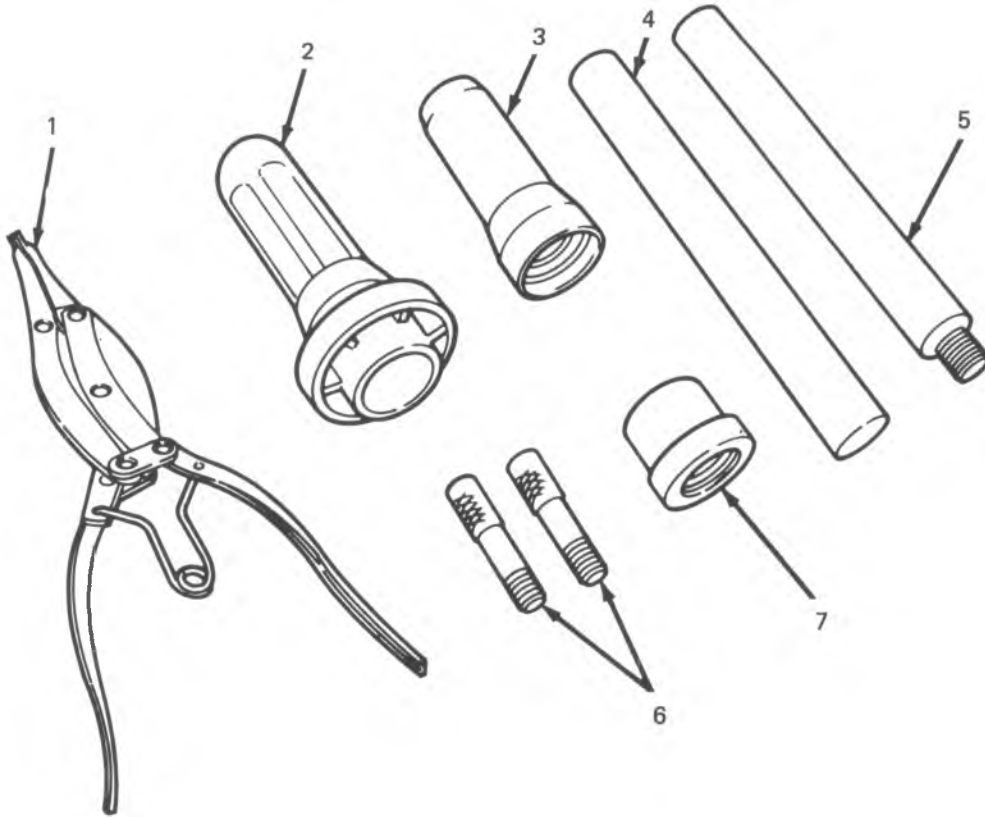

1. J-8059 Snap Ring Pliers
2. J-21426 Rear Extension Seal Installer  
J-21359
3. J-23096 Drive Gear Brg. Retainer Seal Installer
4. J-22246 Countergear Loading Tool
5. J-8092 Driver Handle
6. J-1126 Transmission Guide Pins
7. J-21465-15 Extension Bushing Remover and Installer  
J-23062-14

102879

## 4-SPEED 89MM TRANSMISSION

### CONTENTS

|                                   |   |   |    |
|-----------------------------------|---|---|----|
| On Vehicle Service .....          | 1 | Gears .....                               | 10 |
| Transmission .....                | 1 | Repairs .....                             | 10 |
| Extension Housing Oil Seal.....   | 2 | Synchronizer Keys and Springs .....       | 10 |
| Speedometer Driven Gear .....     | 2 | Extension Oil Seal and/or Bushing.....    | 10 |
| Side Cover .....                  | 3 | Drive Gear Bearing Retainer Oil Seal..... | 11 |
| Unit Repair .....                 | 7 | Transmission Side Cover .....             | 11 |
| Disassembly of Transmission ..... | 7 | Assembly of Countergear .....             | 11 |
| Disassembly of Mainshaft .....    | 8 | Assembly of Drive Gear .....              | 11 |
| Cleaning and Inspection .....     | 9 | Assembly of Mainshaft.....                | 12 |
| Transmission Case .....           | 9 | Assembly of Transmission .....            | 12 |
| Bearing Rollers and Spacers ..... | 9 | Specifications .....                      | 13 |
| Front and Rear Bearings.....      | 9 | Special Tools .....                       | 14 |

### ON VEHICLE SERVICE

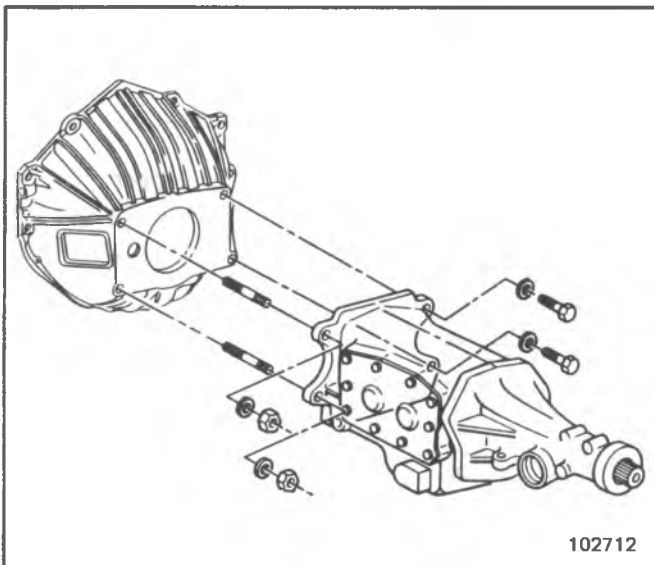

Fig. 7B3-1—Transmission To Engine Attachment

#### TRANSMISSION (Fig. 7B3-1)

##### Removal (Except K Series)

1. Raise vehicle on suitable hoist and drain lubricant from transmission.
2. Disconnect speedometer cable.
3. Remove shift controls from transmission.
4. Disconnect back up lamp switch wire.
5. Disconnect propeller shaft from transmission as described in Section 4A.
6. Position a suitable dolly or jack under the vehicle and adjust to carry the weight of the transmission.
7. Visually inspect to determine if other equipment, lines or brackets must be removed to permit removal of the transmission. Remove crossmember.

**NOTICE:** Be sure to support the clutch release bearing and support assembly during removal of the transmission main drive gear from the flywheel housing. This will prevent the release bearing from

falling out of the flywheel housing when the transmission is removed.

8. Remove transmission-to-clutch housing mounting bolts.

**NOTICE:** When removing the transmission, do not allow the weight of the transmission to hand on the clutch disc hub, as the disc may become distorted, seriously affecting clutch operation.

9. Move the transmission assembly straight away from the engine, using care to keep the transmission main drive gear shaft in alignment with the clutch disc hub. Refer to Fig. 7B3-1.
10. When the transmission is free from the engine, lower the transmission and move from under the vehicle.
11. If desired, a careful check of clutch components should be made after the transmission has been removed. If the clutch requires repair, refer to Section 7C before transmission is reinstalled in the vehicle.

##### Installation

1. Apply a light coating of high temperature grease to the main drive gear bearing retainer and splined portion of transmission main drive gear shaft to assure free movement of clutch and transmission components during assembly.

**NOTICE:** Do not apply an excessive amount of grease in the above areas, as under normal operation this grease could be thrown onto clutch facing resulting in clutch problems.

2. Shift the transmission into high gear. Mount transmission on dolly or jack and move into position under the vehicle. Avoid springing the clutch when the transmission is being installed to the engine. Do not force the transmission into the clutch disc hub. Do not let the transmission hang unsupported in the splined portion of the clutch disc.
3. Align the transmission main drive gear shaft with the clutch disc hub by rotating the transmission companion flange or output yoke. Move the transmission forward, guiding the main drive gear shaft into the clutch disc splines.

4. Install transmission-to-clutch housing mounting bolts and washers. Tighten bolts to specifications.
5. Install crossmember.
6. Connect propeller shaft to transmission as described in Section 4A. Remove transmission jack.
7. Connect back up lamp switch wire.
8. Reconnect speedometer cable at transmission.
9. Reinstall shift controls on transmission.
10. If other equipment (exhaust pipe, support brackets, etc.) was removed, reinstall these parts.
11. Refill transmission with lubricant recommended in Section 0B of this manual.
12. If necessary, adjust clutch or transmission control linkage to achieve proper transmission operation.
13. Lower vehicle.

**Removal (K-Series)**

1. Raise vehicle on hoist.
2. Drain transfer case and transmission. Disconnect the speedometer cable.
3. Disconnect propeller shaft front and rear U-joint yokes at case, and tie up out of way.
4. Disconnect transfer case shift lever at transfer case.
5. Support transfer case in a suitable cradle. Remove bolts attaching transfer case to adapter, and remove the transfer case.
6. Disconnect shift control rods from the shifter levers at the transmission.
7. Support rear portion of engine. Remove two (2) adapter mount bolts.
8. Visually inspect to determine if other equipment, lines or brackets must be removed to permit removal of the transmission. Remove crossmember.
9. Remove the 2 top transmission to clutch housing cap screws and insert 2 transmission guide pins, Tool J-2216 in these holds.
10. Remove the 2 lower transmission-to-clutch housing cap screws.
11. Slide the transmission and adapter assembly straight back on guide pins until the clutch gear is free of splines in the clutch disc. The use of the 2 guide pins during this operation will support the transmission and prevent damage to the clutch disc through springing.
12. Remove the transmission and adapter as an assembly from under the body.
13. Remove adapter from transmission.

**Installation (K-Series)**

1. Apply a light coating of high temperature grease to the main drive gear bearing retainer and splined portion of transmission main drive gear shaft to assure free movement of clutch and transmission components during assembly.

**NOTICE:** Do not apply an excessive amount of grease in the above areas, as under normal operation, this grease could be thrown onto clutch facings, resulting in clutch problems.

2. Shift the transmission into high gear. Mount transmission on dolly or jack and move into position under the vehicle. Avoid springing the clutch when the

transmission is being installed to the engine. Do not force the transmission into the clutch disc hub. Do not let the transmission hang unsupported in the splined portion of the clutch disc.

3. Align the transmission main drive gear shaft with the clutch disc hub by rotating the transmission companion flange or output yoke. Move the transmission forward, guiding the main drive gear shaft into the clutch disc splines.
4. Install transmission-to-clutch housing mounting bolts and washers. Tighten bolts to specifications.
5. Install crossmember and torque bolts to specifications. Install transmission mount bolts and torque to specifications.
6. Support transfer case in a suitable cradle and move into position under the vehicle. Align transfer case to adapter plate and install attaching bolts. Torque bolts to specifications.
7. Connect propeller shaft to transmission as described in Section 4A.
8. Connect speedometer cable.
9. Reinstall shift control at transfer case and adjust as outlined in Section 7E.
10. Reinstall shift controls at transmission and adjust as previously outlined in this section.
11. If other equipment (exhaust pipe, support brackets, parking brake cable, etc.) was removed, reinstall these parts.
12. Refill transmission and transfer case with lubricant recommended in Section 0B of this manual.
13. Lower vehicle.

**EXTENSION HOUSING OIL SEAL****Removal**

1. Raise vehicle.
2. Drain lubricant from transmission.
3. Disconnect propeller shaft from transmission as described in Section 4A.
4. Remove slip joint yoke from rear of transmission mainshaft.
5. Pry seal out of extension housing.

**Installation**

1. Coat outer diameter of new oil seal with sealing cement. Install new oil seal using extension housing oil seal installer (J-21426).
2. Install slip joint yoke on rear of transmission mainshaft.
3. Reconnect propeller shaft to transmission as described in Section 4A.
4. Refill transmission with lubricant recommended in Section 0B.
5. Lower vehicle.

**SPEEDOMETER DRIVEN GEAR****Removal**

1. Raise vehicle.
2. Disconnect speedometer cable, then remove lock plate to housing bolt and lock washer and remove lock

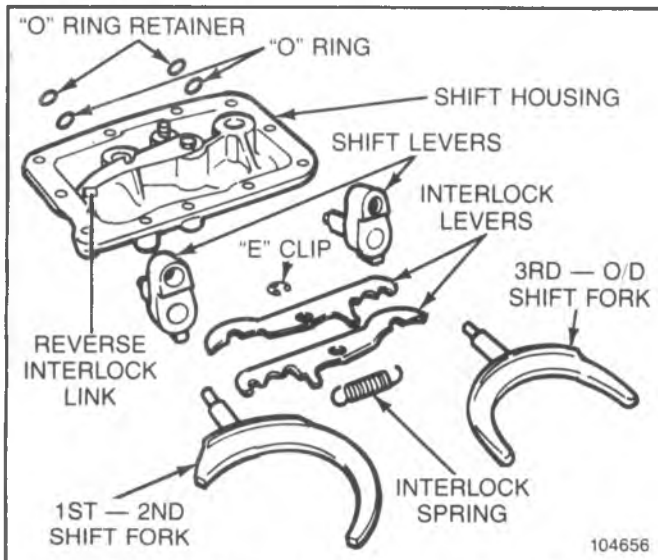

Fig. 7B3-2-Transmission Side Cover Assembly

plate. Insert screw driver in lock plate slot in fitting and pry fitting, gear and shaft from housing. Pry "O" ring from groove in fitting.

#### Installation

1. Install new "O" ring in groove in fitting, coat "O" ring and driven gear shaft with transmission lubricant and insert shaft.
2. Hold the assembly so slot in fitting is toward lock plate boss on housing and install in housing. Push fitting into housing until lock plate can be inserted in groove and attached to housing. Connect speedometer cable.
3. Lower vehicle.

#### SIDE COVER (FIG 7B2-3)

##### Removal

1. Raise vehicle.
2. Disconnect control rods from levers and shift the transmission levers into neutral position.
3. Remove reverse shift lever, side cover bolts, side cover and shift forks. Remove cover assembly from

transmission case carefully as the reverse detent spring and ball will fall out when the cover is removed.

4. Remove nuts attaching shift levers to the shaft. Disengage levers from flats on shafts and remove. Makes sure shafts are free of burrs before removal, otherwise the bores may be scored resulting in leakage.
5. Pull gearshift lever shafts out of cover.
6. Remove "O" ring retainers and "O" rings from housing.
7. Remove "E" ring from interlock lever pivot pin and remove interlock levers and spring from cover.

##### Installation

1. Install interlock levers on pivot pin and fasten with "E" ring. Use pliers to install spring on interlock lever hangers.
2. Grease housing bores and push each shaft into its proper bore followed by greased "O" ring and retainer.
3. Install shift levers and torque retaining nuts to specifications. Be sure 3rd-O/D operating lever points downward.
4. Install new side cover gasket on case using grease to retain it. Install reverse detent ball followed by the spring into its bore.
5. Install the side cover onto case guiding the 3rd-O/D shift fork into its synchronizer groove, then lead the shaft of the 1-2 shift fork into its bore in the side cover. Hold the reverse interlock link against the 1-2 shift lever to provide clearance for the side cover. To seat the side cover, use a screwdriver and raise the interlock lever against its spring tension to allow the 1-2 shift fork to slip under the levers. Be sure the reverse detent spring is positioned in the cover bore.
6. Install side cover bolts finger tight and shift through all gears to insure proper operation. Tighten cover bolts evenly and torque to specifications.
7. Connect control rods to transmission shift levers and adjust if necessary.
8. Remove filler plug and add lubricant specified in Section 0B to level of filler plug hole. Reinstall filler plug.
9. Lower vehicle.

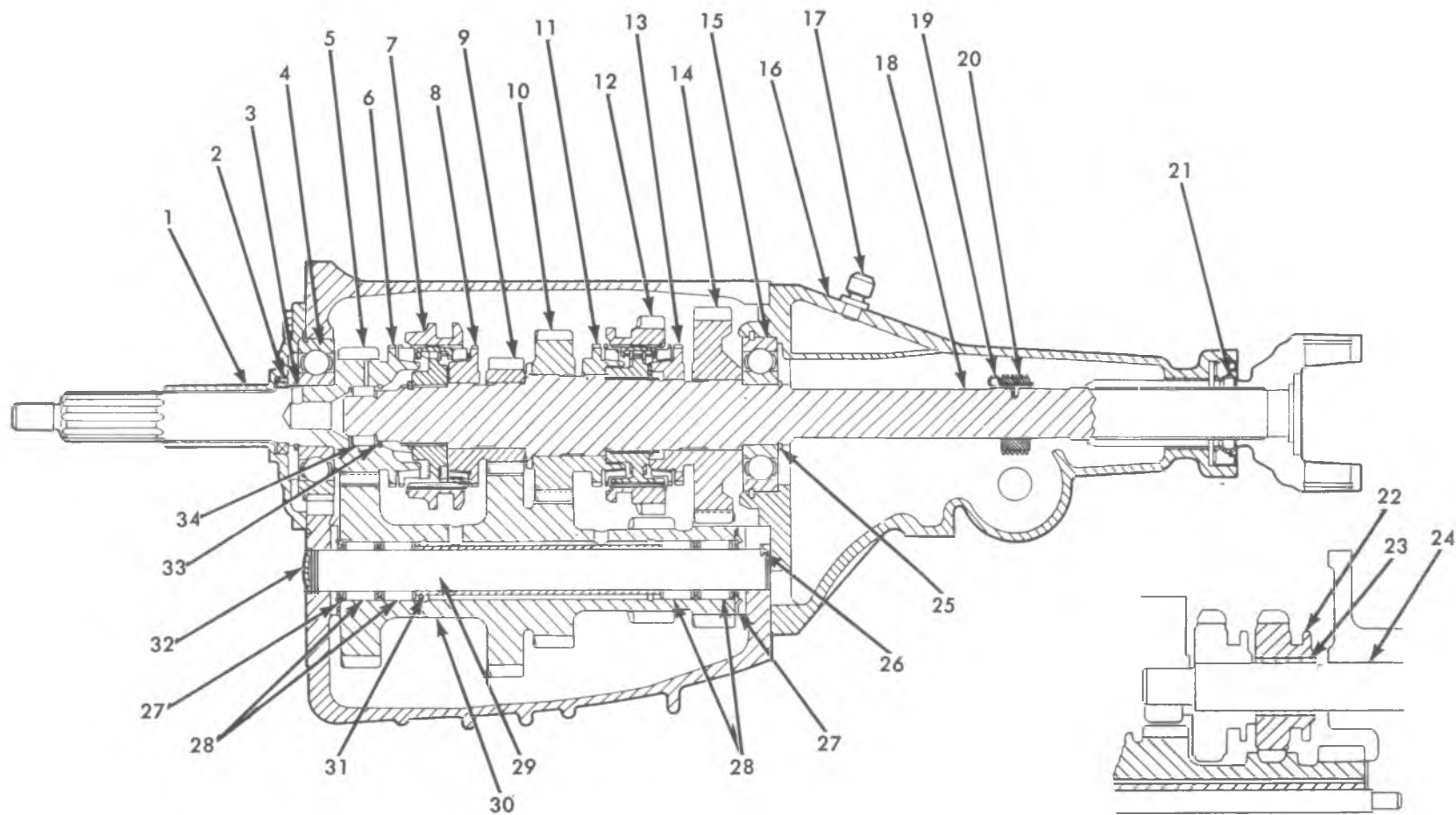

Fig. 7B3-3--4-Speed, 89mm, Cross-Section

- |                                |                                 |                                  |
|--------------------------------|---------------------------------|----------------------------------|
| 1. Drive Gear Bearing Retainer | 12. 1st & 2nd Speed Clutch Assy | 23. Reverse Idler Gear Bushing   |
| 2. Seal                        | 13. Stop Ring                   | 24. Reverse Idler Shaft          |
| 3. Snap Ring                   | 14. First Gear                  | 25. Snap Ring                    |
| 4. Drive Gear Bearing          | 15. Rear Main Bearing           | 26. Woodruff Key                 |
| 5. Drive Gear                  | 16. Extension Housing           | 27. Thrust Washer                |
| 6. Stop Ring                   | 17. Vent Plug                   | 28. Countershaft Roller Bearings |
| 7. 3rd & O/D Speed Clutch Assy | 18. Mainshaft                   | 29. Countershaft                 |
| 8. Stop Ring                   | 19. Retainer Clip               | 30. Countershaft Gear            |
| 9. Overdrive Gear              | 20. Speedometer Gear            | 31. Countershaft Sleeve          |
| 10. Second Gear                | 21. Rear Oil Seal               | 32. Expansion Plug               |
| 11. Stop Ring                  | 22. Reverse Idler Gear          | 33. Snap Ring                    |
|                                |                                 | 34. Drive Gear Roller Bearings   |

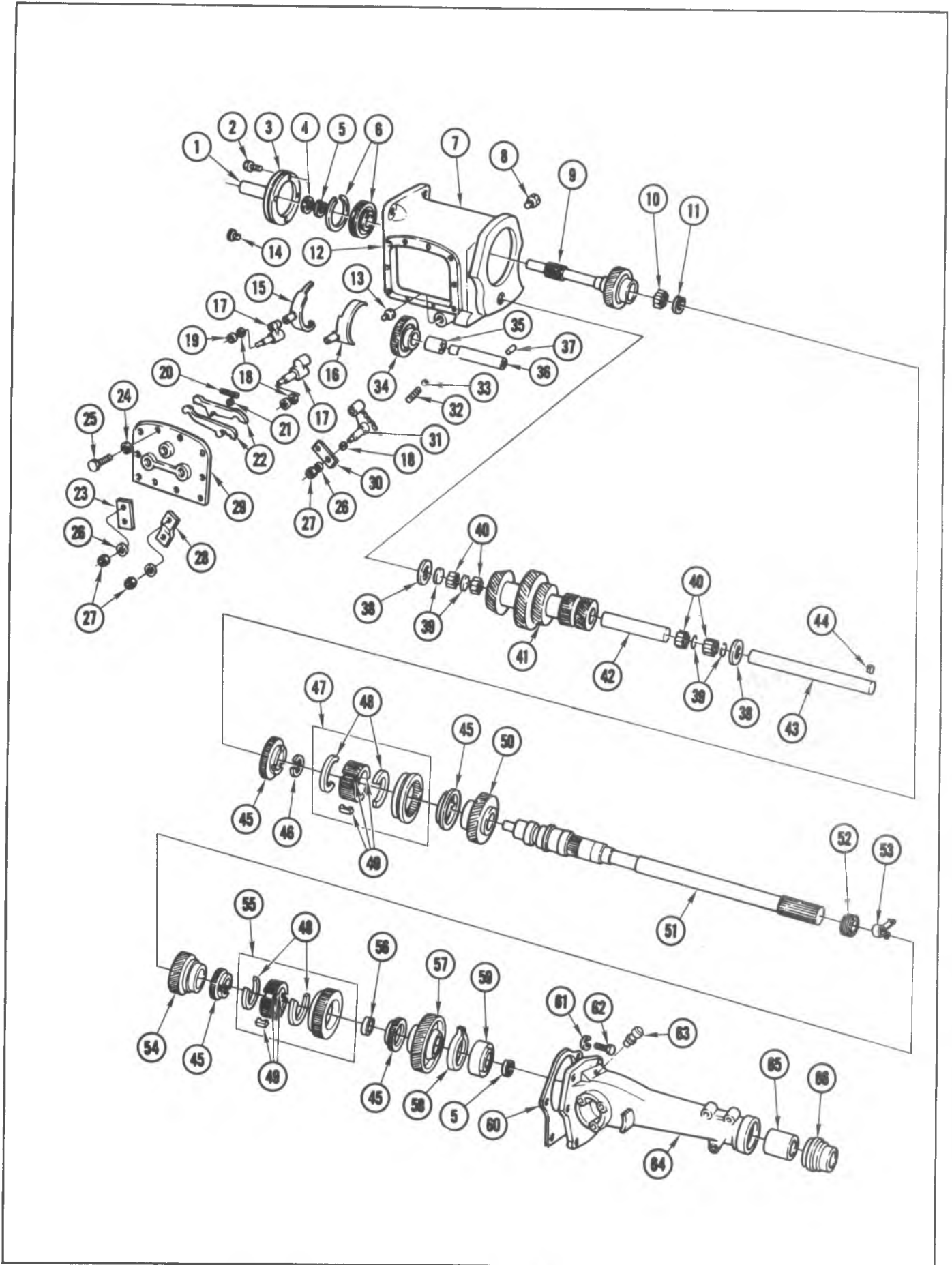

Fig. 7B3-4-4-Speed, 89mm, Exploded View

1. RETAINER, CLUTCH GEAR BEARING
2. BOLT
3. GASKET, CLUTCH GEAR BEARING RETAINER
4. SEAL, CLUTCH GEAR BEARING OIL
5. RING, MAIN DRIVE GEAR SNAP
6. BEARING, W/SNAP RING, MAIN DRIVE GEAR
7. CASE, TRANS
8. PLUG, SQ HD, FILLER
9. GEAR, CLUTCH
10. BEARING, MAINSHAFT ROLLERS
11. RING, PILOT BEARING SNAP
12. GASKET, CONTROL LEVER HOUSING
13. PLUG, DRAIN
14. PLUG, EXPANSION
15. FORK, SHIFT 3RD & 4TH
16. FORK, SHIFT 1ST & 2ND
17. SHAFT, FORWARD SHIFT
18. RING, "O" SHIFT SHAFT SEAL
19. RETAINER, SHIFT SHAFT SEAL
20. SPRING, DETENT
21. RING, "E"
22. CAM, DETENT
23. LEVER, CONTROL SHIFT 3RD & 4TH
24. WASHER, LK
25. BOLT
26. WASHER, FLAT
27. NUT
28. LEVER, CONTROL SHIFT 1ST & 2ND
29. COVER, TRANS
30. LEVER, REVERSE SHIFT
31. SHAFT, REVERSE SHIFT
32. SPRING, REVERSE SHIFT SHAFT DETENT BALL
33. BALL, STEEL
34. GEAR, REVERSE IDLER
35. BUSHING, REVERSE IDLER GEAR
36. SHAFT, REVERSE IDLER
37. KEY, REVERSE IDLER SHAFT
38. WASHER, CLUTCH COUNTER GEAR THRUST
39. SPACER, CLUTCH COUNTER GEAR BEARING
40. BEARING, COUNTER GEAR ROLLERS
41. GEAR, COUNTER
42. SPACER, CLUTCH COUNTER GEAR BEARING
43. SHAFT, COUNTER GEAR
44. KEY, COUNTER GEAR
45. RING, SYN BLOCKING
46. RING, SYN 3RD & 4TH SNAP
47. SYNCHRONIZER ASM, TRANS 3RD & 4TH
48. SPRING, FORWARD CLUTCH KEY
49. KEY, FORWARD SYN CLUTCH
50. GEAR, 4TH SPEED
51. SHAFT, MAIN
52. GEAR, SPEEDO DRIVE
53. CLIP, SPEEDO DRIVE GEAR
54. GEAR, 2ND SPEED
55. SYNCHRONIZER ASM, TRANS 1ST & 2ND
56. RING, SYN CLUTCH GEAR SNAP
57. GEAR, 1ST SPEED
58. RING, MAIN SHAFT BEARING OUTER SNAP
59. BEARING, CLUTCH GEAR
60. GASKET, EXTENSION
61. WASHER, LK
62. SCREW
63. VENTILATOR, EXTENSION
64. EXTENSION, TRANS
65. BUSHING, TRANS EXTENSION
66. SEAL, EXTENSION OIL

Fig. 7B3-5-89mm Identification

## UNIT REPAIR

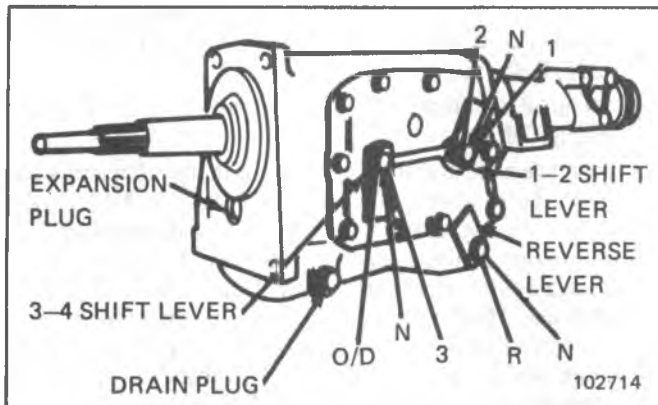

Fig. 7B3-6--Transmission Shift Levers

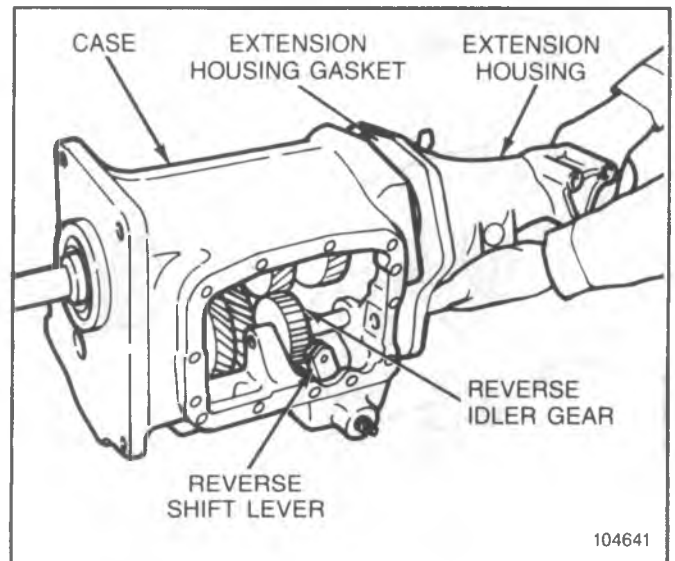

Fig. 7B3-8--Extension Housing and Mainshaft Assembly

## TRANSMISSION

### Disassembly

1. Thoroughly clean the exterior of the transmission assembly.
2. Remove drain plug and drain lubricant from transmission.
3. Shift transmission into neutral position. Remove reverse shift lever, side cover bolts, side cover and shift forks. Refer to Fig. 7B3-6. Remove reverse detent spring and ball from base in side of case.
4. Remove extension housing bolts and rotate the extension on the output shaft to expose the rear of the countershaft. Clearance has been provided on the extension flange to enable one bolt to be reinstalled to hold the extension in the inverted position to gain access for the countershaft removal. Refer to Fig. 7B3-7.
5. With a centerpunch or drill, make a hole in the countershaft expansion plug at the front of the case.

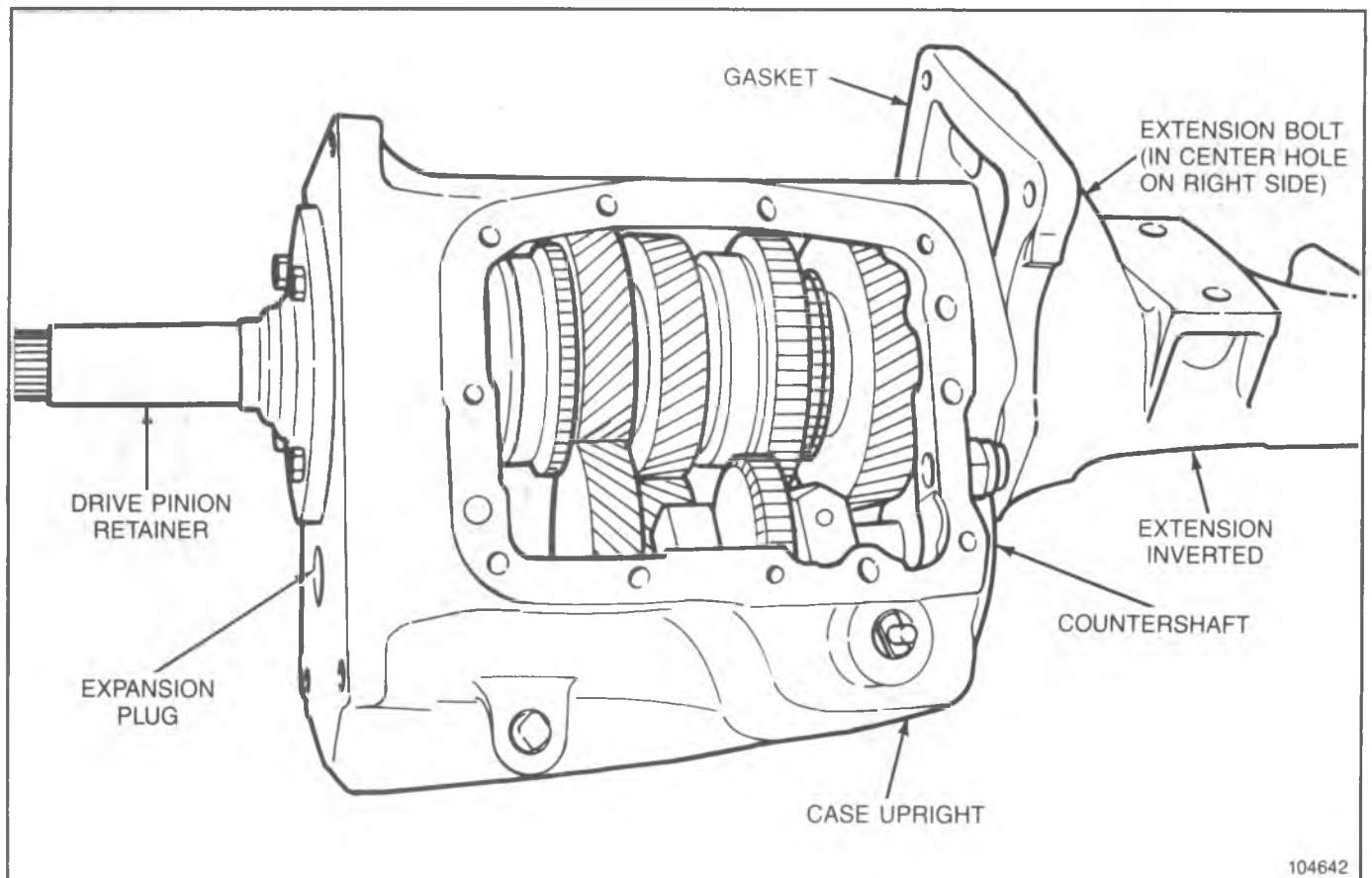

Fig. 7B3-7--Rotating Extension Housing



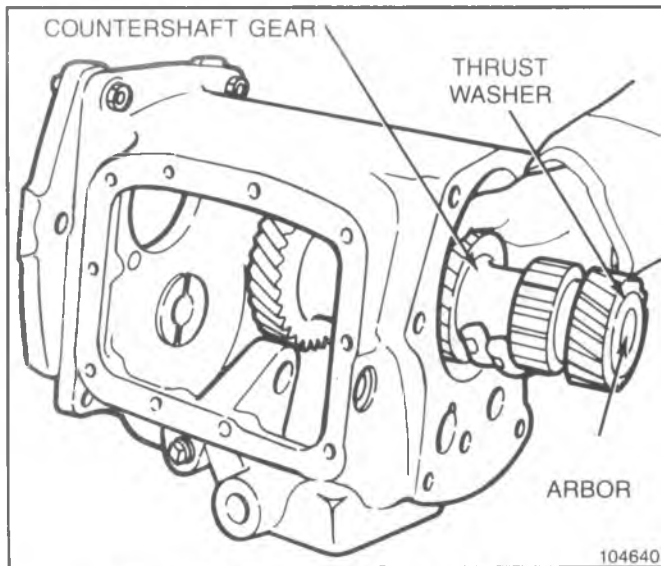

Fig. 7B3-9--Countershaft Gear and Arbor

6. Using this hole, push the countershaft rearward until the woodruff key is exposed. Remove key and push the countershaft forward against the expansion plug. Using a brass drift, tap the countershaft forward until the plug is driven out of the case.
7. Using tool J-29793 at the front of the countershaft, drive the shaft out the rear of the case. Tool J-29793 will now hold the roller bearings in position within the gear bore. Lower countershaft gear to bottom of case.
8. Rotate the extension housing back to its normal position.
9. Remove drive gear bearing retainer bolts and slide retainer and gasket off the gear assembly.
10. Using a brass drift, tap the gear and bearing assembly forward and remove through front of case. Replacement of the drive gear or bearing require no further disassembly of the transmission. Replace the failed part and reassemble the transmission.
11. Slide third and overdrive (O/D) synchronizer

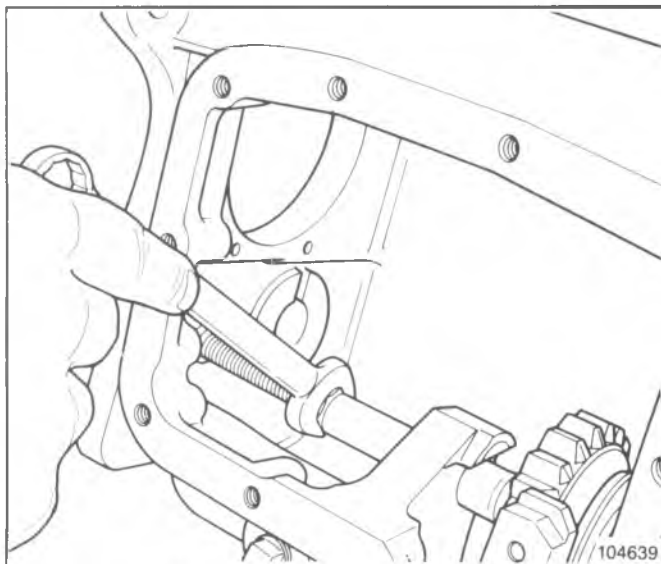

Fig. 7B3-10--Reverse Idler Shaft

sleeve slightly forward, slide reverse idler gear to center of its shaft, then using a soft faced hammer, tap on extension housing in a rearward direction. Slide housing and mainshaft assembly out and away from case. Refer to Fig. 7B3-8.

12. Remove countershaft gear from bottom of case. Refer to Fig. 7B3-9.
13. Remove the reverse idler gear shaft from transmission case. To remove the shaft, use a 3/8" x 3-1/2" bolt with a free spinning nut and a 7/16" deep socket 3/8 inch drive. Place the bolt and socket in the case with the socket against the shaft and the head of the bolt against the case. Holding the head of the bolt, turn nut against the socket pushing shaft through its bore. Remove gear from shaft and remove shaft with woodruff key from transmission case. Refer to Fig. 7B3-10.
14. Remove reverse gear shift lever shaft from case by pushing shaft inward and remove it from the case. Remove "O" ring and retainer from case bore.
15. Remove backup light switch from case.

## MAINSHAFT

### Disassembly

Refer to Fig. 7B3-11 for locations of various gears, synchronizer sleeves and clutches before disassembling mainshaft.

1. Remove snap ring that retains 3rd and O/D synchronizer clutch gear and sleeve assembly. Then slide 3rd and O/D synchronizer assembly off end of mainshaft. Refer to Fig. 7B3-12.
2. Slide O/D gear and stop ring off mainshaft. Mark and separate synchronizer parts for cleaning and inspection.
3. Using long nose pliers, spread snap ring that retains mainshaft ball bearing in extension housing, then pull mainshaft assembly out of the extension housing. Refer to Fig. 7B3-13.
4. Remove speedometer drive gear from mainshaft.
5. Remove snap ring that retains mainshaft bearing on the shaft. Refer to Fig. 7B3-14. Remove bearing from

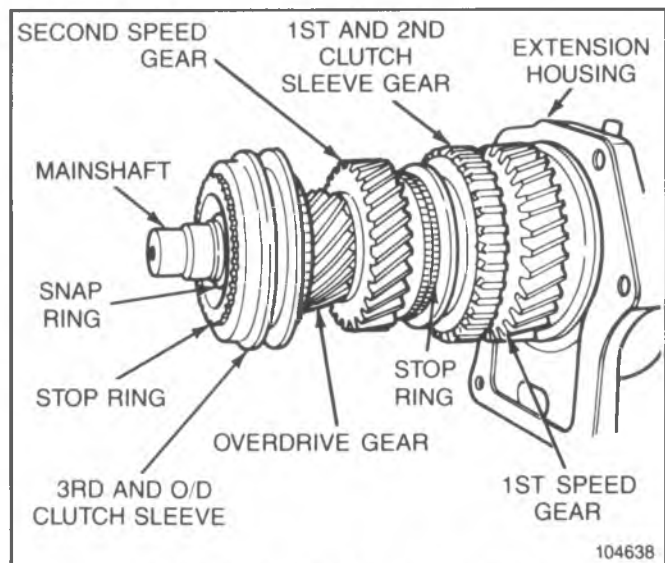

Fig. 7B3-11--Mainshaft Gear Identification

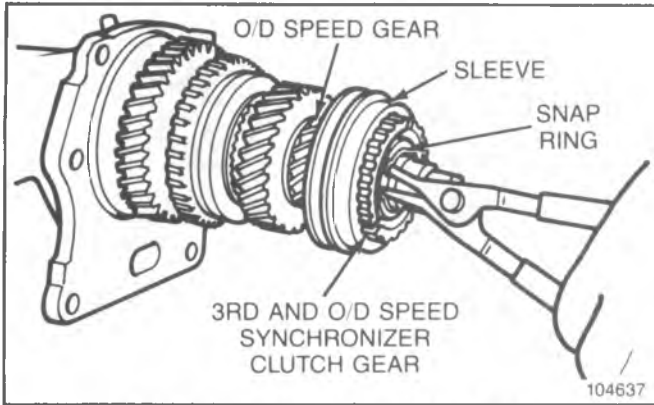

Fig. 7B3-12--Disassembling Mainshaft

mainshaft by inserting steel plate on the front side of 1st gear, then press mainshaft through bearing. (Be carefully not to damage gear teeth).

6. Remove bearing, bearing retainer ring, 1st gear, and 1st speed stop ring from the shaft.
7. Remove snap ring that retains 1st and 2nd clutch gear and sleeve assembly. Then slide 1st and 2nd gear and sleeve assembly from the mainshaft. Remove 2nd gear. Before cleaning, mark all parts for reassembly. Refer to Fig. 7B3-15.
8. Inspect mainshaft gear bearing surfaces for signs of wear, scoring, or any condition that would not allow shaft to be used.
9. Remove tool J-29793 from the countershaft gear, 76 needle type bearings, thrust washers, and spacers.
10. Remove outer snap ring on the drive gear. Using an arbor press, remove bearing from drive gear, if bearing is to be replaced.
11. Remove inner snap ring and 16 bearing rollers from cavity of drive gear.

## CLEANING AND INSPECTION

### Transmission Case

1. Wash the transmission thoroughly inside and outside using a suitable solvent, then inspect the case for

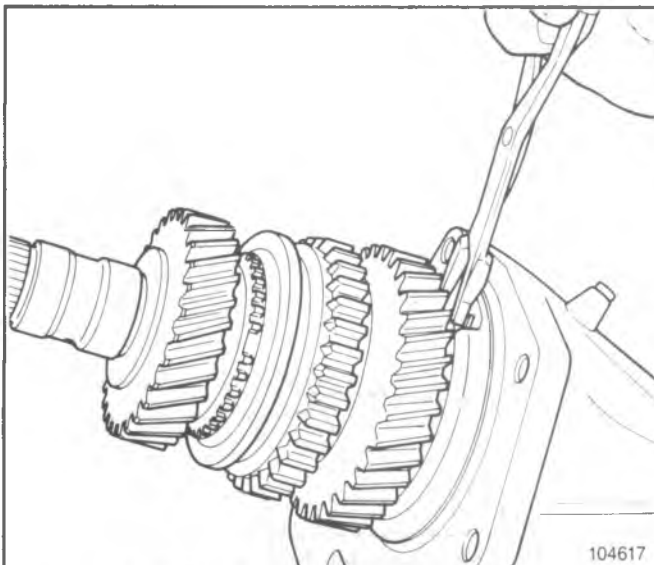

Fig. 7B3-13--Mainshaft Bearing Snap Ring

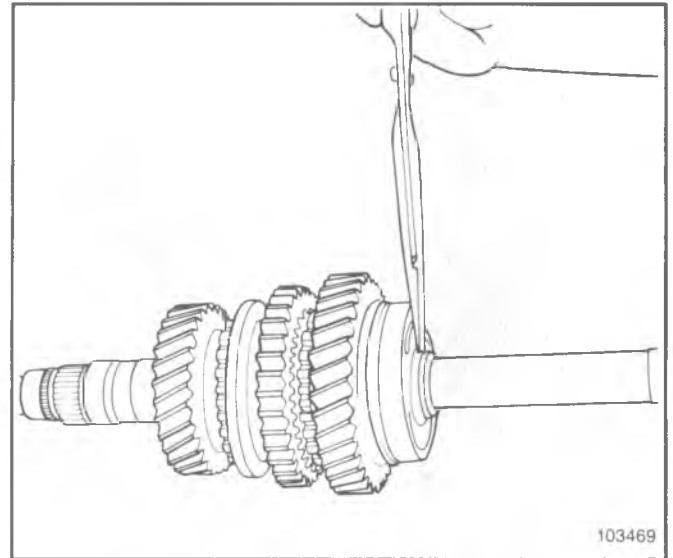

Fig. 7B3-14--Mainshaft Bearing Snap Ring

cracks. The magnetic disc is glued in place, wipe with a clean cloth.

2. Check the front and rear faces for burrs and if present, dress them off with a fine mill file.

### Roller Bearings and Spacers

1. All main drive gear and countergear bearing rollers should be inspected closely and replaced if they show wear. Inspect countershaft and reverse idler shaft at the same time, replace if necessary. Replace all worn spacers.

### Front and Rear Bearings

1. Wash the front and rear ball bearings thoroughly in a cleaning solvent.
  2. Blow out bearings with compressed air.
- NOTICE:** Do not allow the bearings to spin. Turn them slowly by hand. Spinning bearings may damage the race and balls.
3. Lubricate bearings with a light oil and check them

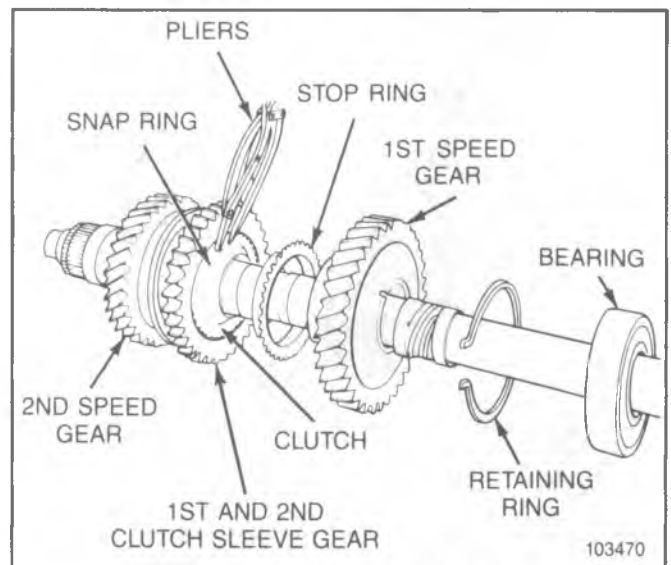

Fig. 7B3-15--Clutch Gear Snap Ring

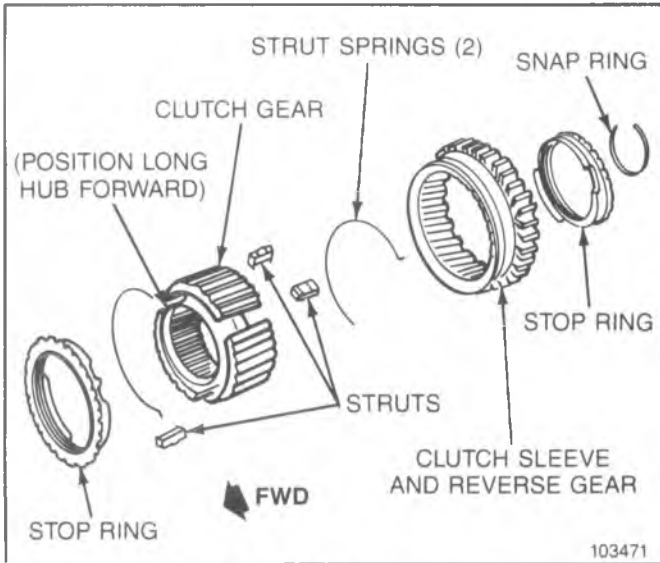

Fig. 7B3-16--1st-2nd Synchronizer Disassembled

for roughness by slowly turning the race by hand.

**Gears**

1. Inspect all gears for excessive wear, chips or cracks and replace any that are worn or damaged.
2. Check oil seal contact area on the drive gear shaft, if it's pitted, rusted or scratched, a new gear is recommended for best seal life.
3. Inspect interlock levers for cracks at detent and clearance notches at each end of levers.
4. Inspect shift forks for wear on pads and shafts. Inspect the fork shaft bores in the shift lever for galling.

**REPAIRS**

**Synchronizer Keys and Springs**

**Replacement**

The synchronizer hubs and sliding sleeves are a selected assembly and should be kept together as originally

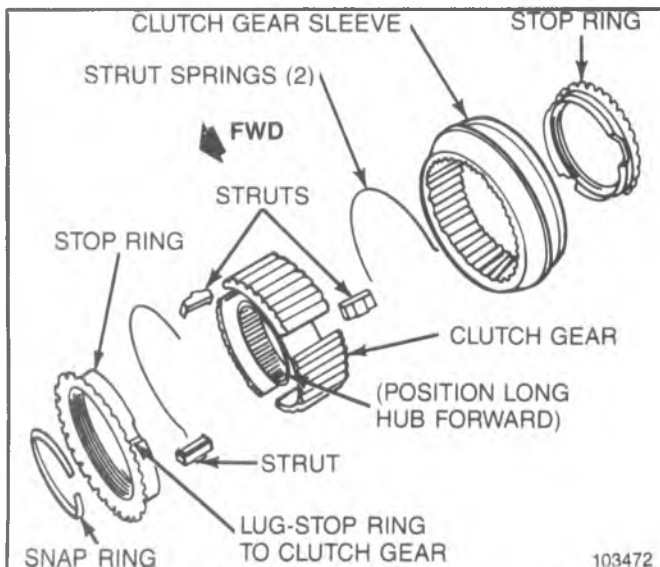

Fig. 7B3-17--3rd-O/D Synchronizer Disassembled

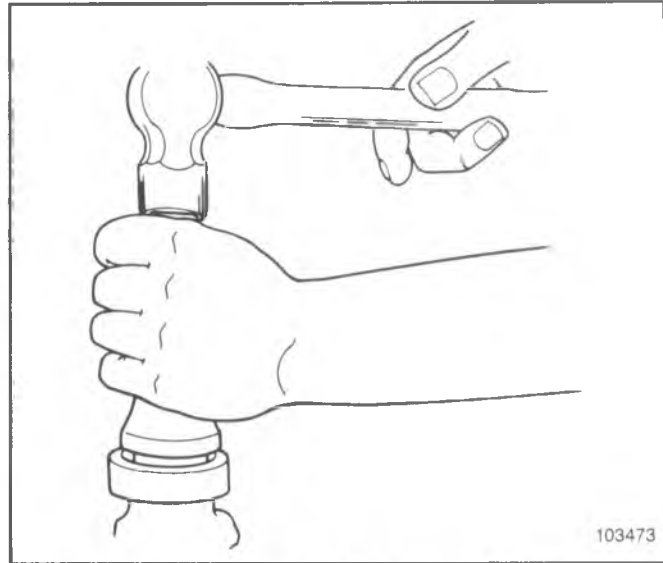

Fig. 7B3-18--Installing Rear Extension Bushing

assembled, but the keys and springs may be replaced if worn or broken.

1. If relation of hub and sleeve are not already marked, mark for assembly purposes. Refer to Fig. 7B3-16 and 7B3-17.
2. Push the hub from the sliding sleeve, the keys will fall free and the spring may be easily removed.
3. Place the keys in position and while holding them in place, slide the sleeve onto the hub, aligning the marks made before disassembly.
4. Place the two springs in position (one on each side of hub), so all three keys are engaged by both springs.

**Extension Oil Seal and/or Bushing**

**Replacement**

1. Pry oil seal out of extension housing, using a screwdriver or small chisel.
2. Drive the brushing out of housing, using tool J-8092 with J-21424-9.

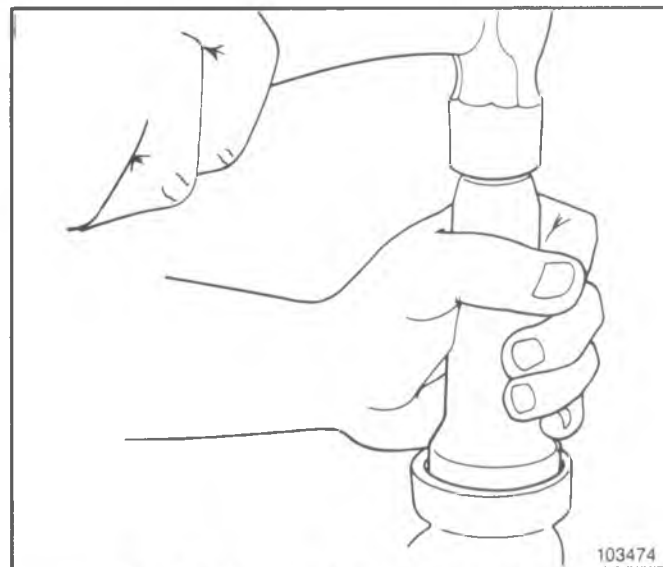

Fig. 7B3-19--Installing Rear Extension Seal

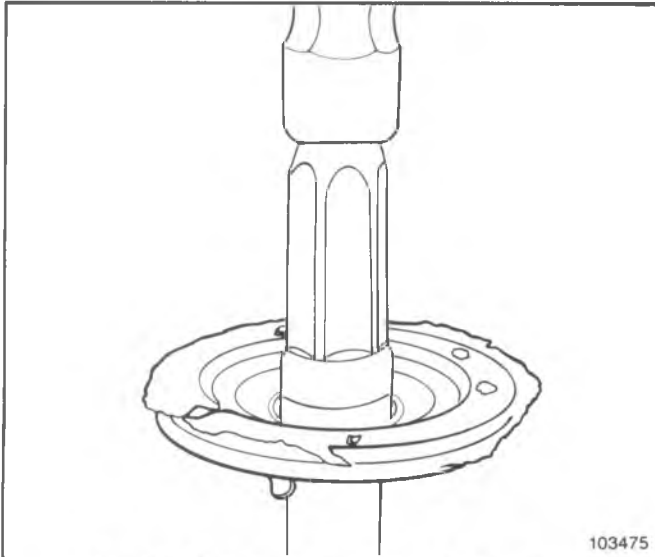

Fig. 7B3-20--Drive Gear Bearing Retainer Seal

3. Slide a new bushing on tool J-23596 and drive bushing into place. Refer to Fig. 7B3-18.
4. Position a new seal in opening of extension housing and drive it into the housing with tool J-21426. Refer to Fig. 7B3-19.

### Drive Gear Bearing Retainer Oil Seal

#### Replacement

1. Pry out old seal.
2. Using a new seal, install new seal into retainer using Tool J-23096 until it bottoms in bore. Refer to Fig. 7B3-20. Lubricate I.D. of seal with transmission lubricant.

### Transmission Side Cover (Fig. 7B3-21)

The following three steps need only be done if oil leakage is visible around gearshift lever shifts, or the interlock levers are cracked.

1. Remove nuts that attach shift operating levers to the shafts. Disengage levers from flats on shafts

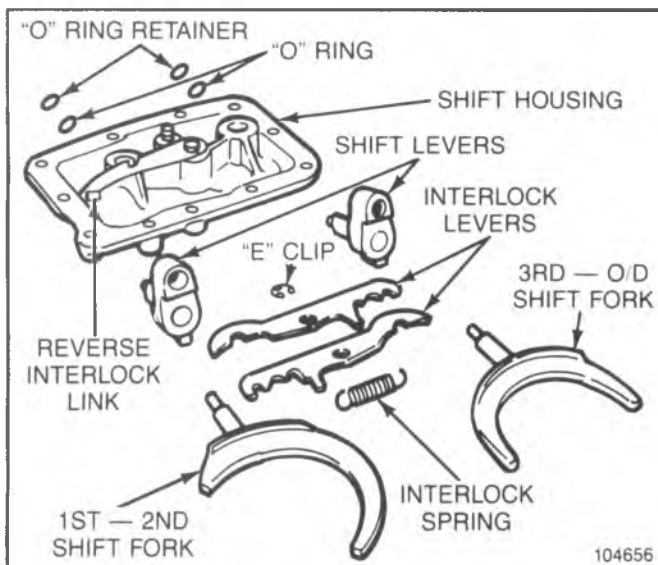

Fig. 7B3-21--Side Cover Exploded View

and remove. Make sure shafts are free of burrs before removal, otherwise the bores may be scored resulting in leakage after reassembly.

2. Pull gearshift lever shafts out of cover.
3. Remove "O" ring retainers and "O" rings from housing.
4. Remove "E" ring from interlock lever pivot pin and remove interlock levers and spring from cover.
5. To assemble side cover, install interlock levers on pivot pin and fasten with "E" ring. Use pliers to install spring on interlock lever hangers.
6. Grease housing bores and push each shaft into its proper bore followed by greased "O" ring and retainer.
7. Install operating levers and torque retaining nuts to specifications. Be sure 3rd-O/D operating levers point downward.

### COUNTERGEAR

#### Assembly

1. Coat inside bore of countergear at each end with a thin film of grease and install spacer with Tool J-29793 into gear. Center spacer and arbor.
2. Install 19 roller bearings, followed by a spacer ring and 19 more bearings and a spacer ring into each end of gear.
3. If countershaft thrust washers are worn or scored, install new thrust washers. Coat washers with grease and install one at the front of the countergear on the arbor with the tang side facing the case bore. Install the other washer after the countergear assembly is positioned in the bottom of the case.

### DRIVE GEAR

#### Assembly

1. Press drive gear bearing on drive gear seating bearing fully against shoulder on gear. Be sure outer snap ring groove is toward the front. Refer to Fig. 7B3-22.
2. Install a new snap ring on shaft to retain bearing. Be sure snap ring is seated. This snap ring is a select fit for minimum end play.
3. Place drive gear in a vise (with soft jaws), then install 16 bearing rollers in cavity of shaft. Coat bearing rollers with grease, then install retaining snap ring in its groove.

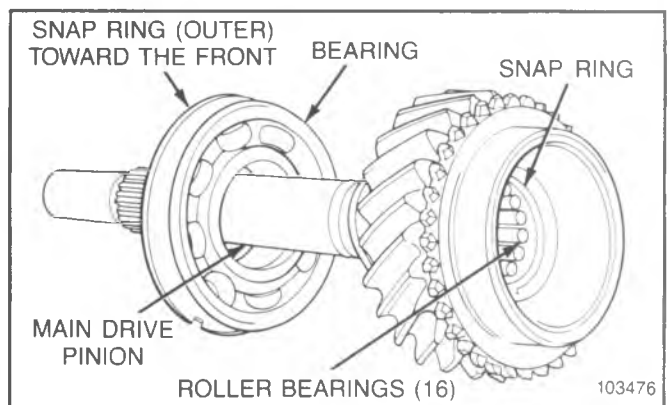

Fig. 7B3-22--Drive Pinion and Bearing Assembly

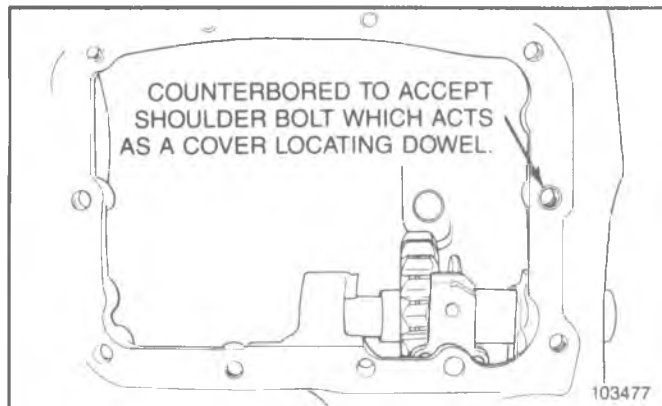

Fig. 7B3-23--Side Cover Bolt Identification

## MAINSHAFT

### Assembly

- Slide second gear over mainshaft (synchronizer cone toward rear) and down against shoulder on shaft. Refer to Fig. 7B3-15.
- Slide 1st-2nd synchronizer assembly (including stop ring with lugs indexed in hub slots) over mainshaft, down against 2nd gear cone and secure with a new snap ring. Slide next stop ring over shaft and index lugs into clutch hub slots. Refer to Fig. 7B3-15.
- Slide first gear (synchronizer cone toward clutch sleeve gear just installed) over mainshaft into position against clutch sleeve gear.
- Install mainshaft bearing retainer ring, followed by mainshaft rear bearing. Using an arbor and a suitable tool, drive or press bearing down into position. Install a new snap ring on shaft to secure bearing. Refer to Fig. 7B3-14. This snap ring is a select fit for minimum end play.
- Install partially assembled mainshaft into extension housing far enough to engage bearing retaining ring in slot in extension housing. Expand snap ring with pliers so that mainshaft ball bearing can move in and bottom against its thrust shoulder in extension housing. Release ring and seat it all around its groove in extension housing. Refer to Fig. 7B3-13.
- Slide overdrive gear over mainshaft (with synchronizer cone toward front) followed by O/D gear stop ring.
- Install 3rd-O/D synchronizer clutch gear assembly on mainshaft (shift fork slot toward rear) against O/D gear. Be sure to index rear stop ring with clutch gear struts. Install retaining snap ring. Refer to Fig. 7B3-12.
- Using grease, position front stop ring over clutch gear, again indexing ring lugs with struts.

## TRANSMISSION

### Assembly

- Place the transmission case on its side with the shift cover opening toward the assembler.
- Install countergear assembly into the case aligning the tangs on the front washer with the slots in the case. Next install the rear washer aligning the tangs with the slot at the rear of the case and then let the countergear rest in the bottom of the case. (Be sure thrust washers stay in position). Refer to Fig. 7B3-9).
- Coat a new extension gasket with grease, then place it in position on the extension.
- Insert mainshaft assembly into the case tilting it as required to clear the countershaft gear.
- Rotate the extension housing to expose the rear of the countershaft bore. Install one bolt to hole the extension in inverted position and prevent it from moving rearward. Refer to Fig. 7B3-7.
- Install drive gear assembly through the front of the case and position it in the front bore. Install outer snap ring in bearing groove. Tap lightly into place using a soft faced hammer. If everything is in proper position, the outer snap ring will bottom onto the case face without excessive effort. If not, check to see if a strut, roller bearing, or a stop ring is out of position.
- Raise the countergear assembly into position with the teeth meshed with the drive gear. Make sure thrust washer remain in position on ends of the arbor and tangs are aligned with slots in case.
- Start the countershaft into the rear bore of the case and push forward until the shaft is approximately half way through the gear. Install woodruff key and push the shaft forward until end is flush with case. Remove arbor Tool J-29793.
- Install reverse shift lever shaft in case bore followed by greased "O" ring and retainer.
- Remove extension housing bolt and rotate extension to provide clearance for installation of the reverse idler gear in end of case.
- Push the shaft in far enough to position reverse idler gear on protruding end of shaft with fork slot toward rear. At the same time, engage slot with reverse shift fork.
- Install woodruff key on shaft and drive shaft in flush with end of case.
- Align extension housing to case and install bolts. Torque housing bolts to specifications.
- Install drive gear bearing retainer and gasket. Coat threads with sealing compound, then install bolts and torque to specifications.
- Install new expansion plug coated with sealing compound in countershaft bore at front of case.
- Position both synchronizer sleeves in neutral. Place the 1-2 shift fork into the groove of the 1-2 synchronizer sleeve. Slide reverse idler gear to neutral.
- Rotate each shift lever to neutral position (straight up) and install 3rd/overdrive shift fork into its bore and under both interlock levers.
- Position side cover gasket on case using grease to retain it. Install reverse detent ball followed by the spring into its bore in the case.
- Lower the side cover onto the case guiding the 3rd/overdrive shift fork into its synchronizer groove, then lead the shaft of the 1-2 shift fork into its bore in the side cover. Hold the reverse interlock link against the 1-2 shift lever to provide clearance as the side cover is lowered into position. To finish the installation of the side cover, use a screwdriver and raise the interlock lever against its spring tension to allow the 1-2 shift fork to slip under the levers. Be sure the reverse detent spring is positioned in the cover bore.

20. Eight of the side cover bolts are shoulder bolts with one having a longer shoulder which acts as a dowel to accurately locate the side cover. The remaining two bolts are standard bolts. Install cover bolts finger tight and shift through all gears to insure proper operation. Refer to Fig. 7B3-23 for location of cover bolts.
21. Tighten side cover bolts evenly and torque to specifications.
22. Install reverse shift lever, retaining nut and torque to specifications.
23. Shift the transmission into each gear to insure correct shift travel and smooth operation. The reverse shift lever and 1-2 shift lever have cam surfaces which mate in reverse position to lock the 1-2 lever, fork and synchronizer in neutral position. Slight motion of the 1-2 shift lever toward low gear is normal during shifting into reverse gear.
24. Install backup light switch and torque to specifications.

## SPECIFICATIONS

|   |         |            |        |
|---|---------|------------|--------|
| Shift Lever Retaining Nuts              | 24 N·m  | 18 ft. lb. |        |
| Extension to Case Bolts                 | 68 N·m  | 50 ft. lb. |        |
| Drive Gear Bearing Retainer Bolts       | 41 N·m  | 30 ft. lb. |        |
| Side Cover to Case Bolts                | 20 N·m  | 15 ft. lb. |        |
| Backup Light Switch                     | 20 N·m  | 15 ft. lb. |        |
| Lubrication Filler Plug                 | 20 N·m  | 15 ft. lb. |        |
| Transmission to Clutch Housing Bolts    | 100 N·m | 75 ft. lb. |        |
| Crossmember to Frame Bolts              | 75 N·m  | 55 ft. lb. |        |
| Crossmember to Mount Bolts              | 55 N·m  | 40 ft. lb. |        |
| Shift Lever and Bracket To Transmission | 50 N·m  | 36 ft. lb. |        |
| Control Rod Adjusting Nuts              | 20 N·m  | 15 ft. lb. |        |
| Mount to Transmission Bolts             | 55 N·m  | 40 ft. lb. | 102709 |

## SPECIAL TOOLS

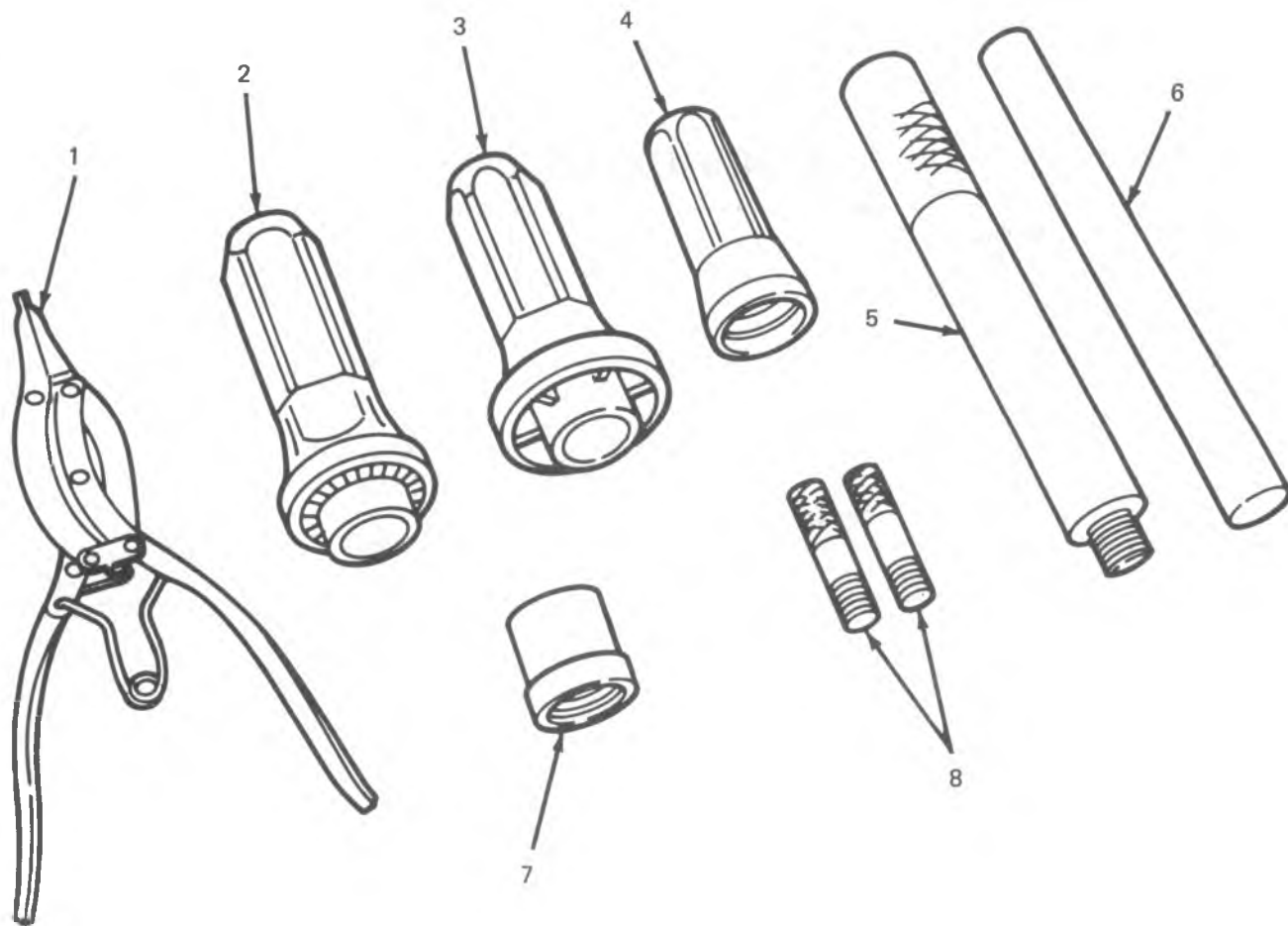

1. J-8059 Snap Ring Pliers
2. J-23596 Rear Extension Bushing Installer
3. J-21426 Rear Extension Seal Installer
4. J-23096 Drive Gear Retainer Seal Installer
5. J-8092 Driver Handle
6. J-29793 Countergear Loading Tool
7. J-21424-9 Rear Extension Bushing Remover
8. J-1126 Transmission Guide Pins



# 4-SPEED 117MM TRANSMISSION

## CONTENTS

|                                   |   |  |    |
|-----------------------------------|---|--|----|
| On Vehicle Service .....          | 1 | Front and Rear Bearings .....              | 7  |
| Transmission .....                | 1 | Gears .....                                | 9  |
| Extension Housing Oil Seal .....  | 2 | Repairs .....                              | 9  |
| Speedometer Driven Gear .....     | 2 | Synchronizer Keys and Springs .....        | 9  |
| Floor Shift Control Lever .....   | 3 | Drive Gear Bearing Retainer Oil Seal ..... | 9  |
| Unit Repair .....                 | 6 | Transmission Cover .....                   | 9  |
| Disassembly of Transmission ..... | 6 | Assembly of Countergear .....              | 10 |
| Disassembly of Drive Gear .....   | 7 | Assembly of Drive Gear .....               | 11 |
| Disassembly of Mainshaft .....    | 7 | Assembly of Mainshaft .....                | 12 |
| Disassembly of Countershaft ..... | 7 | Assembly of Transmission .....             | 13 |
| Cleaning and Inspection .....     | 7 | Specifications .....                       | 15 |
| Transmission Case .....           | 7 | Special Tools .....                        | 16 |
| Bearing Rollers and Spacers ..... | 7 |  |    |

## ON VEHICLE SERVICE

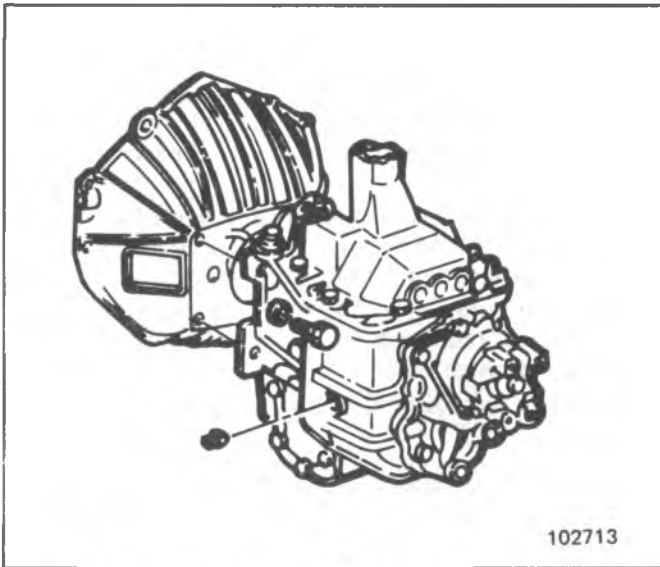

Fig. 7B4-1--Transmission To Engine Attachment

### TRANSMISSION (Fig. 7B4-1)

#### Removal (Except K Series)

1. Remove attaching screws from transmission shift lever boot retainer. Slide boot and retainer up lever and remove transmission shift lever.  
To remove shift lever, push down on collar and turn counter-clockwise.
2. Raise vehicle and support engine with a suitable floor stand.
3. Drain transmission and disconnect the speedometer cable from transmission.
4. Disconnect propeller shaft front U-joint at transmission yoke, and tie up out of way.
5. Disconnect exhaust pipes at exhaust manifolds.
6. Remove transmission mount-to-crossmember bolts.

7. Support transmission with a suitable floor stand. Remove frame to crossmember bolts and remove crossmember from vehicle.
8. Remove transmission-to-clutch housing attaching bolts. Remove upper bolts first and install transmission guide pins J-1126. Use of the guide pins will prevent damage to the clutch assembly.
9. Slide transmission rearward until main drive gear clears the clutch assembly and lower assembly from vehicle.
10. If desired, a careful check of clutch components should be made after the transmission has been removed. If the clutch requires repair, refer to Section 7C before transmission is reinstalled in the vehicle.

#### Installation

1. Apply a light coating of high temperature grease to the main drive gear bearing retainer and splined portion of transmission main drive gear shaft to assure free movement of clutch and transmission components during assembly.

**NOTICE:** Do not apply an excessive amount of grease in the above areas, as under normal operation this grease could be thrown onto clutch facing resulting in clutch problems.

2. Position transmission to the clutch housing and install attaching bolts. Torque bolts to specification.
3. Position frame crossmember and install retaining bolts. Install transmission mount-to-crossmember bolts. Torque bolts to specifications.
4. Connect propeller shaft at transmission and torque bolts to specification.
5. Connect speedometer cable.
6. Connect exhaust pipes to exhaust manifolds.
7. Fill transmission with lubricant specified in Section 0B.
8. Remove supports and lower vehicle.
9. Install transmission shift lever, boot, retainer and attaching screws.



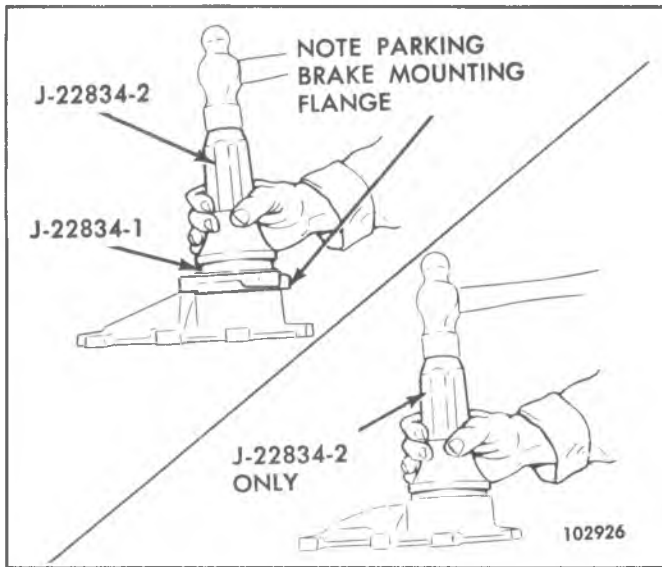

Fig. 7B4-2--Rear Bearing Retainer Oil Seal

**Remove (K-Series)**

1. Remove attaching screws from transmission shift lever boot retainer. Slide boot and retainer up lever and remove transmission shift lever.  
To remove shift lever, push down on collar and turn counter-clockwise.
2. Raise vehicle and support engine with a suitable floor stand. Drain transfer case and transmission.
3. Disconnect speedometer cable.
4. Disconnect propeller shafts at transfer case and tie up, away from work area.
5. Support transfer case in a suitable cradle. Remove bolts attaching transfer case to adapter, and remove transfer case. Refer to Section 7E.
6. Disconnect exhaust pipes at exhaust manifolds.
7. Remove transmission mount-to-crossmember bolts.
8. Support transmission and remove frame to crossmember bolts. Rotate crossmember to clear frame rails and remove from vehicle.
9. Remove transmission-to-clutch housing attaching bolts. Remove upper bolts first and install transmission guide pins J-1126. Use of the guide pins will prevent damage to the clutch assembly.
10. Slide transmission rearward until main drive gear clears the clutch assembly and lower assembly from vehicle.
11. If desired, a careful check of clutch components should be made after the transmission has been removed. If the clutch requires repair, refer to Section 7C before transmission is reinstalled in the vehicle.

**Installation**

1. Apply a light coating of high temperature grease to the main drive gear bearing retainer and splined portion of transmission main drive gear shaft to assure free movement of clutch and transmission components during assembly.

**NOTICE:** Do not apply an excessive amount of grease in the above areas, as under normal operation this grease

could be thrown onto clutch facings resulting in clutch problems.

2. Position transmission-to-clutch housing. Install bolts attaching transmission to clutch housing and torque to specifications.
3. Position crossmember and install attaching bolts. Install transmission mount to crossmember bolts. Torque bolts to specifications.
4. Position transfer case to adapter and install attaching bolts. Torque bolts to specifications.
5. Connect propeller shafts to transfer case. Torque bolts to specifications.
6. Connect speedometer cable.
7. Connect exhaust pipes to exhaust manifolds.
8. Fill transmission and transfer case with lubricant recommended in Section OB of this manual.
9. Remove supports and lower vehicle.
10. Install transmission shift lever, boots, retainers and attaching screws.

**EXTENSION HOUSING OIL SEAL (Fig 7B4-2)****Removal**

1. Raise vehicle.
2. Drain lubricant from transmission.
3. Disconnect propeller shaft and tie up out of way.
4. Disconnect speedometer cable and remove speedometer driven gear.
5. Using flange or yoke holding tool, remove the output yoke or companion flange nut. Pull output yoke and companion flange nut off the mainshaft.
6. Support transmission while removing mounting bolts and bearing retainer bolts. Remove bearing retainer and gasket. Discard gasket.
7. Remove oil seal. Discard oil seal.

**Installation**

1. Clean gasket surfaces. Coat outer diameter of new oil seal with sealing cement. Install oil seal using Tool J-22834-2 as shown in Fig. 7B4-2.
2. Install the rear bearing cap with a new gasket on the transmission. Install attaching bolts and torque to specifications.
3. Install output yoke on mainshaft. Using a flange or yoke holding tool, install retaining nut. Torque retaining nut to specification.
4. Install speedometer driven gear, then connect speedometer cable.
5. Connect propeller shaft to transmission as described in Section 4A.
6. Fill transmission with lubricant recommended in Section OB.
7. Lower vehicle.

**SPEEDOMETER DRIVEN GEAR****Removal**

1. Raise vehicle.
2. Disconnect speedometer cable, then remove lock plate to housing bolt and lock washer and remove lock plate. Insert screwdriver in lock plate slot in fitting and pry fitting, gear and shaft from housing. Pry "O" ring

from groove in fitting.

**Installation**

1. Install new "O" ring in groove in fitting, coat "O" ring and driven gear shaft with transmission lubricant and insert shaft.
2. Hold the assembly so slot in fitting is toward lock plate boss on housing and install in housing. Push fitting into housing until lock plate can be inserted in groove and attached to housing.
3. Install speedometer cable and lower vehicle.

**FLOOR SHIFT CONTROL LEVER****Removal**

1. On K-Series models, remove transfer case shift lever boot retainer attaching screws and retainer from compartment floor.

2. Remove transmission shift lever boot retainer attaching screws.
3. Slide boot and retainer up on shift lever and remove the shift lever.

**Installation**

1. Install transmission shift lever. Slide boot and retainer down shift lever and install attaching screws.
2. On K-Series models, install transfer case shift lever boot, retainer and attaching screws.

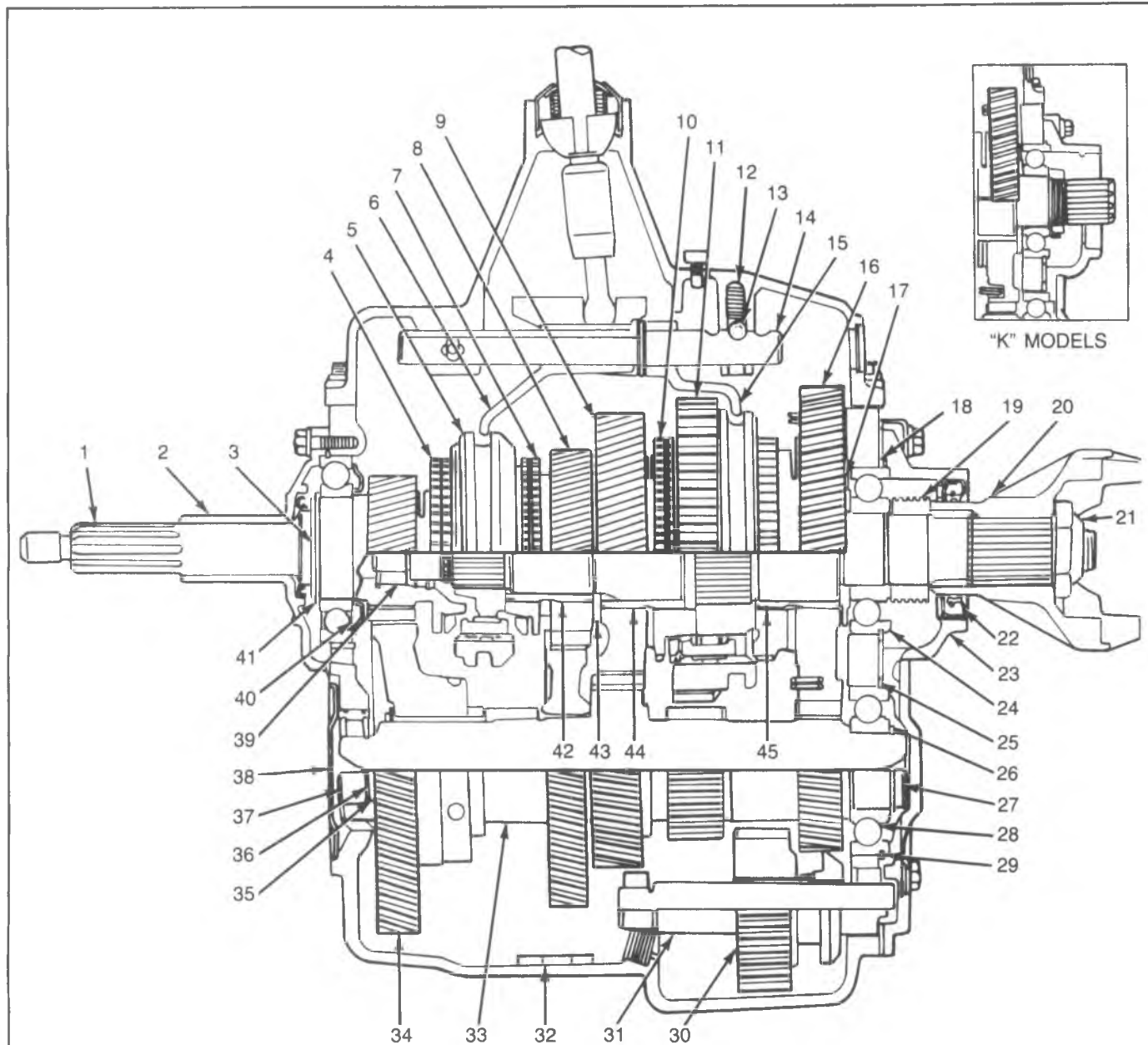

- |  |                                    |                               |                                |
|--|------------------------------------|-------------------------------|--------------------------------|
| 1. MAIN DRIVE GEAR                     | 11. REVERSE DRIVEN GEAR            | 24. MAINSHAFT REAR BEARING    | 37. FRONT COUNTERSHAFT BEARING |
| 2. DRIVE GEAR BEARING RETAINER         | 12. POPPET SPRING                  | 25. REAR BEARING SNAP RING    | 38. COUNTERGEAR FRONT COVER    |
| 3. SNAP RING — OUTER                   | 13. POPPET BALL                    | 26. SNAP RING                 | 39. PILOT BEARING ROLLERS      |
| 4. 3RD AND 4TH SYNCHRONIZER RING       | 14. SHIFT RAIL                     | 27. COUNTERSHAFT BEARING      | 40. CLUTCH GEAR OIL SLINGER    |
| 5. 3RD AND 4TH SYNCHRONIZER COLLAR     | 15. 1ST AND 2ND SHIFT FORK         | 28. COUNTERSHAFT REAR BEARING | 41. SNAP RING                  |
| 6. 3RD AND 4TH SHIFT FORK              | 16. 1ST SPEED GEAR                 | 29. BEARING SNAP RING         | 42. 3RD SPEED GEAR BUSHING     |
| 7. 3RD AND 4TH SPEED SYNCHRONIZER RING | 17. THRUST WASHER                  | 30. REVERSE IDLER GEAR        | 43. THRUST WASHER              |
| 8. 3RD SPEED GEAR                      | 18. BEARING SNAP RING              | 31. REVERSE IDLER SHAFT       | 44. 2ND SPEED GEAR BUSHING     |
| 9. 2ND SPEED GEAR                      | 19. SPEEDOMETER DRIVE GEAR         | 32. CASE MAGNET               | 45. 1ST SPEED GEAR BUSHING     |
| 10. 1ST AND 2ND SYNCHRONIZER ASSEMBLY  | 20. OUTPUT YOKE                    | 33. SPACER                    |                                |
|  | 21. FLANGE NUT                     | 34. COUNTERGEAR THRUST WASHER |                                |
|  | 22. REAR BEARING RETAINER OIL SEAL | 35. THRUST WASHER             |                                |
|  | 23. REAR BEARING RETAINER          | 36. SNAP RING                 |                                |

Fig. 7B4-3--4-Speed 117mm Transmission-Cross Section

Fig. 7B4-4-4-Speed 117mm Transmission-Exploded View

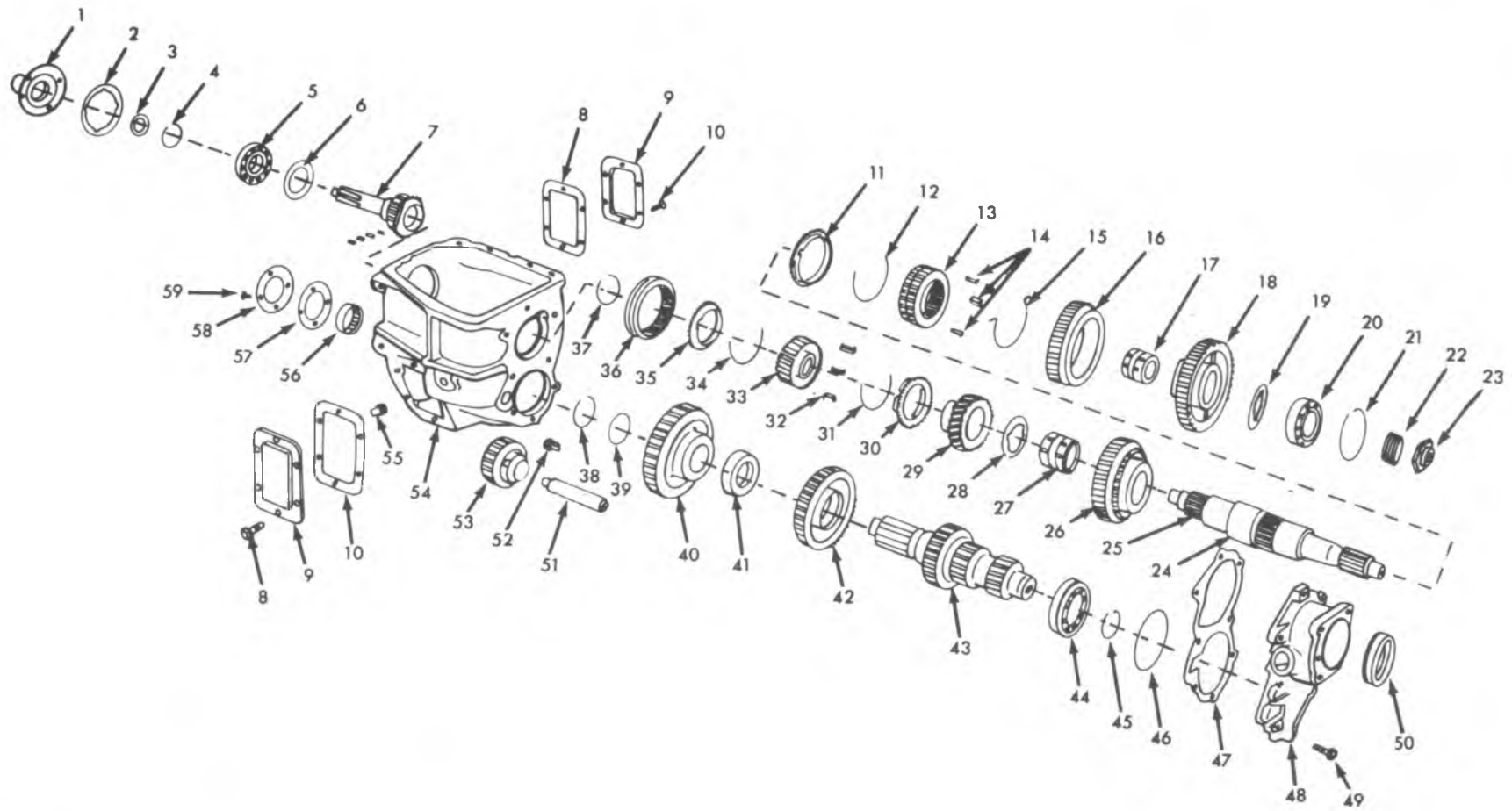

- |  |                                    |                                       |                              |                                  |
|--|------------------------------------|---------------------------------------|------------------------------|----------------------------------|
| 1. Drive Gear Bearing Retainer           | 13. 1st-2nd Speed Synchronizer Hub | 26. 2nd Speed Gear                    | 37. Snap Ring                | 48. Rear Retainer Retainer Bolts |
| 2. Retainer Gasket                       | 14. Synchronizer Keys              | 27. 3rd Gear Bushing                  | 38. Snap Ring                | 49. Retainer Lip Seal            |
| 3. Lip Seal                              | 15. Synchronizer Spring            | 28. Thrust Washer                     | 39. Thrust Washer            | 50. Retainer Lip Seal            |
| 4. Snap Ring                             | 16. Reverse Driven Gear            | 29. 3rd Speed Gear                    | 40. Clutch Countergear       | 51. Reverse Idler Shaft          |
| 5. Drive Gear Bearing                    | 17. 1st Gear Bushing               | 30. 3rd Speed Blocker Ring            | 41. Spacer                   | 52. Drain Plug                   |
| 6. Oil Slinger                           | 18. 1st Gear                       | 31. Synchronizer Spring               | 42. 3rd Speed Countergear    | 53. Reverse Idler Gear           |
| 7. Drive Gear and Pilot Bearings         | 19. Thrust Washer                  | 32. Synchronizer Keys                 | 43. Countergear Shaft        | 54. Case                         |
| 8. Power Take-Off Cover Gasket           | 20. Rear Main Bearing              | 33. 3rd-4th Synchronizer Hub          | 44. Countergear Rear Bearing | 55. Fill Plug                    |
| 9. Power Take-Off Cover Retaining Screws | 21. Bearing Snap Ring              | 34. Synchronizer Spring               | 45. Snap Ring                | 56. Countergear Front Bearing    |
| 10. Retaining Screws                     | 22. Speedometer Gear               | 35. 3rd-4th Speed Blocker Ring        | 46. Bearing Outer Snap Ring  | 57. Gasket                       |
| 11. 1st-2nd Speed Blocker Ring           | 23. Rear Mainshaft Lock Nut        | 36. 3rd-4th Speed Synchronizer Sleeve | 47. Rear Retainer Gasket     | 58. Front Cover Ring             |
| 12. Synchronizer Spring                  | 24. 2nd Speed Bushing (On Shaft)   |                                       |                              | 59. Cover Screws                 |
|  | 25. Mainshaft                      |                                       |                              |                                  |

104613

## UNIT REPAIR

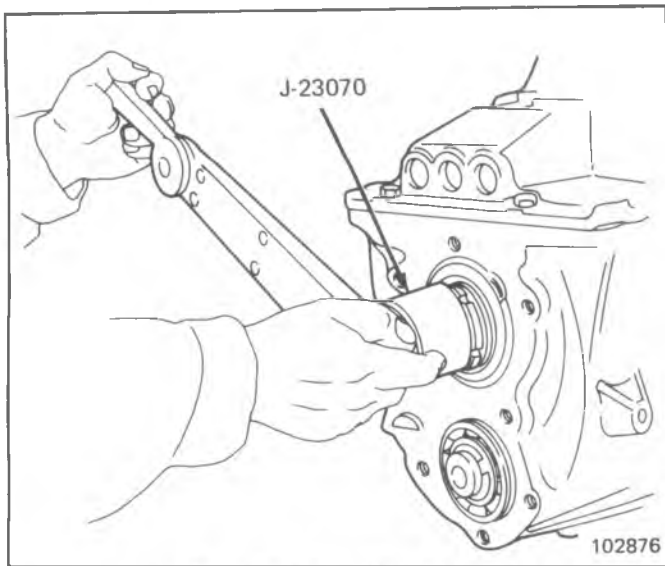

Fig. 7B4-5--Four Wheel Drive

## TRANSMISSION

### Disassembly (Fig. 7B4-3, 7B4-4)

1. Mount transmission in suitable holding fixture and remove cap screws attaching transmission cover assembly to transmission case. If required, insert two 5/16 x 18 screws in cover flange threaded holes and turn evenly to raise cover dowel pins from case.

Move reverse shifter fork so that reverse idler gear is partially engaged before attempting to remove cover. Forks must be positioned so rear edge of the slot in the reverse fork is in line with the front edge of the slot in the forward forks as viewed through tower opening.

2. Place transmission in two gears at once to lock gears. Remove the universal joint flange nut, universal joint front flange and brake drum assembly.

On models equipped with 4-wheel drive transfer case,

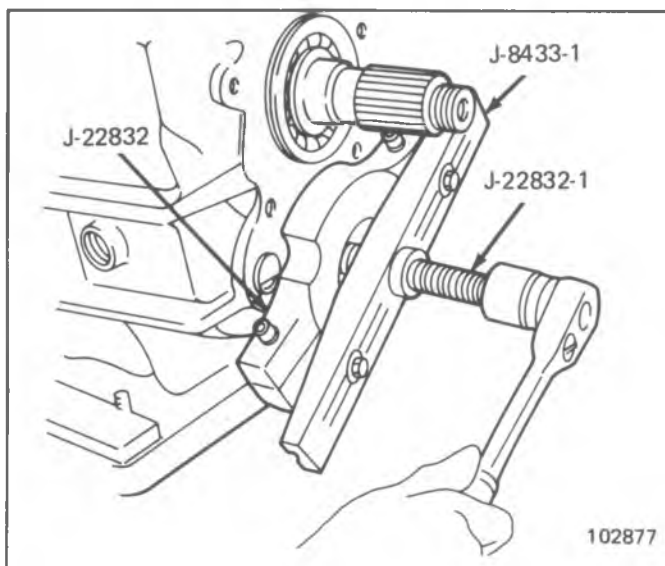

Fig. 7B4-6--Countergear Rear Bearing

use Tool J-23070 to remove mainshaft rear lock nut (Fig. 7B4-5.)

3. Remove parking brake and brake flange plate assembly on model equipped with propeller shaft parking brake. Refer to Section 5, Truck Shop Manual.
4. Remove rear bearing retainer and gasket.
5. Slide speedometer drive gear off mainshaft.
6. Remove drive gear bearing retainers and gasket.
7. Remove countergear front bearing cap and gasket.
8. Pry countergear front bearing out by inserting a two-pronged puller J-28509 through the cast slots in case.
9. Remove countergear rear bearing retaining rings (snap ring) from shaft and bearing. Using Tool J-22832 and J-8433-1, remove countergear rear bearings (Fig. 7B4-6). This will allow countergear assembly to rest on bottom of case.

Make sure Tool J-22832 engages full circumference of groove in bearing to prevent tool damage.

10. Remove drive gear bearing outer race to case retaining ring.
11. Remove drive gear and bearing by tapping gently on bottom side of drive gear shaft and prying directly opposite against the case and bearing snap ring groove at the same time. Remove 4th gear synchronizer ring.

Index cut out section of drive gear in down position with countergear to obtain clearance for removing clutch gear.

12. Remove rear mainshaft bearing retainer ring (snap ring) and using Tool J-22832 and J-8433-1, remove bearing from case (Fig. 7B4-7). Slide 1st speed gear thrust washer off mainshaft.
13. Raise rear of mainshaft assembly and push rearward in case bore, then swing front end up and lift from case. Remove synchronizer cone from shaft.
14. Slide reverse idler gear rearward and move

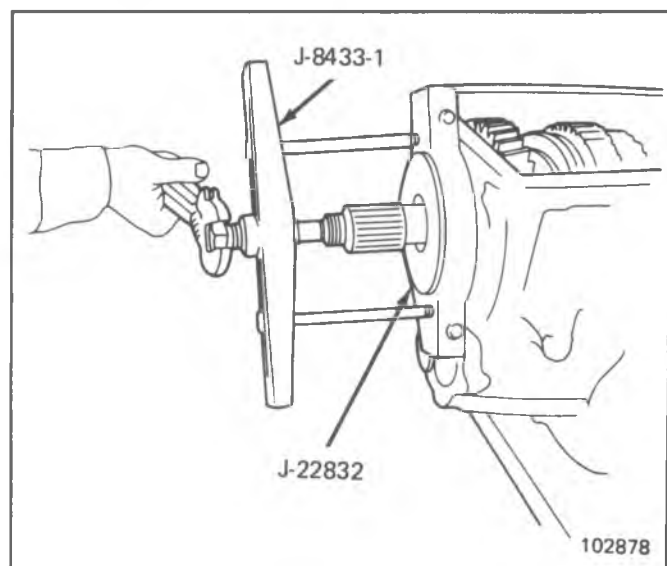

Fig. 7B4-7--Mainshaft Rear Bearing

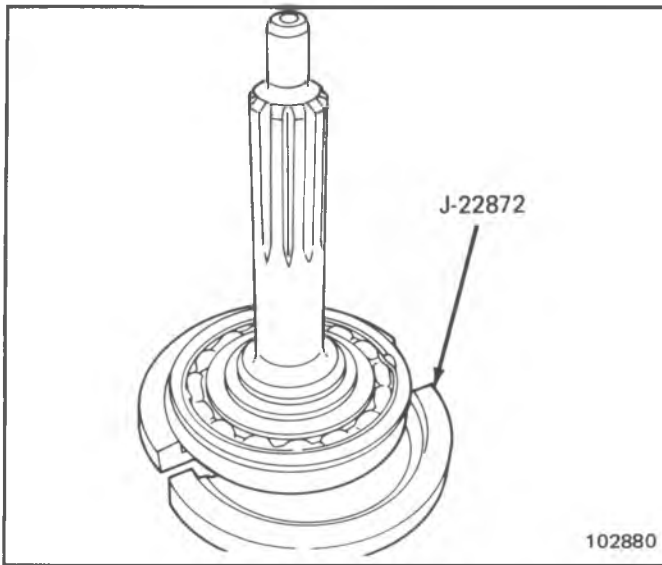

Fig. 7B4-8--Tool J-22872

countergear rearward until front end is free of case, then lift to remove from case.

15. To remove reverse idler gear, drive reverse idler gear shaft out of case from front to rear using a drive. Remove reverse idler gear from case.

## DRIVE GEAR

### Disassembly

1. Remove mainshaft pilot bearing rollers (17) from drive gear if not already removed, and remove roller retainer. Do not remove snap ring on inside of drive gear.
2. Remove snap ring securing bearing on stem of drive gear.
3. To remove bearing, position Tool J-22872 to the bearing (Fig. 7B4-8) and using an arbor press and Tool J-358-1 press gear and shaft out of bearing (Fig. 7B4-9).

## MAINSHAFT ASSEMBLY

### Disassembly (Fig. 7B4-10)

1. Remove first speed gear and thrust washer.
2. Remove snap ring in front of 3rd-4th synchronizer assembly.
3. Remove reverse driven gear.
4. Press behind second speed gear to remove 3rd-4th synchronizer assembly, 3rd speed gear and 2nd speed gear along with 3rd speed gear bushing and thrust washer (Fig. 7B4-11).
5. Remove 2nd speed synchronizer ring.
6. Supporting 2nd speed synchronizer hub at front face, press mainshaft through removing 1st speed gear bushing and 2nd speed synchronizer hub.
7. Split 2nd speed gear bushing and chisel and remove bushing from shaft. Exercise care not to damage mainshaft.

## COUNTERSHAFT

### Disassembly

1. Remove front countergear retaining ring and thrust washer. Discard snap ring.
2. Install Tool J-22832 or suitable press plates on countershaft, open side to spacer, (Fig. 7B4-12); support assembly in an arbor press and press countershaft out of clutch countergear assembly. Countergear is a slip fit and pressing may not be required.
3. Remove clutch countergear rear retaining ring.
4. Remove 3rd speed countergear retaining ring.
5. Position assembly on an arbor press and press shaft from 3rd speed countergear.

## CLEANING AND INSPECTION

### Transmission Case

1. Wash the transmission thoroughly inside and outside using a suitable solvent, then inspect the case for cracks. The magnetic disc is glued in place, wipe with a clean cloth.
2. Check the front and rear faces for burrs and if present, dress them off with a fine mill file.

### Roller Bearings and Spacers

1. All bearing rollers should be inspected closely and replaced if they show wear. Replace all worn spacers.

### Front and Rear Bearings

1. Wash the front and rear ball bearings thoroughly in a cleaning solvent.
2. Blow out bearings with compressed air.
 

**NOTICE:** Do not allow the bearings to spin. Turn them slowly by hand. Spinning bearings may damage the race and balls.
3. Lubricate bearings with a light engine oil and check them for roughness by slowly turning the race by hand.

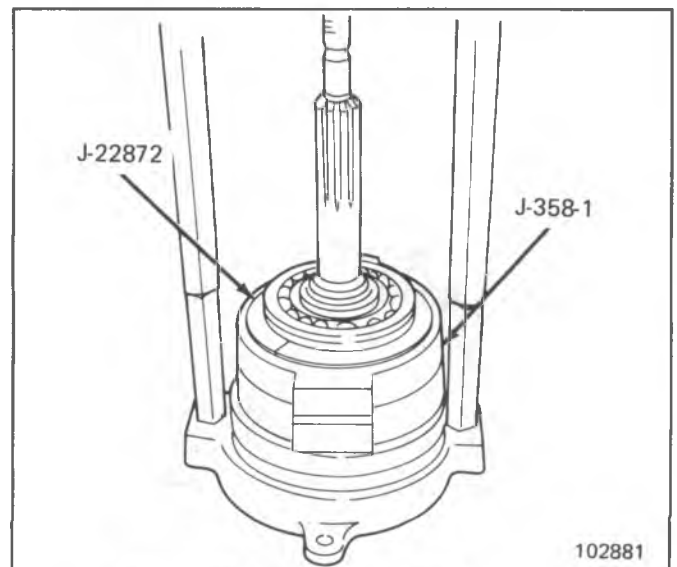

Fig. 7B4-9--Removing Drive Gear Bearing

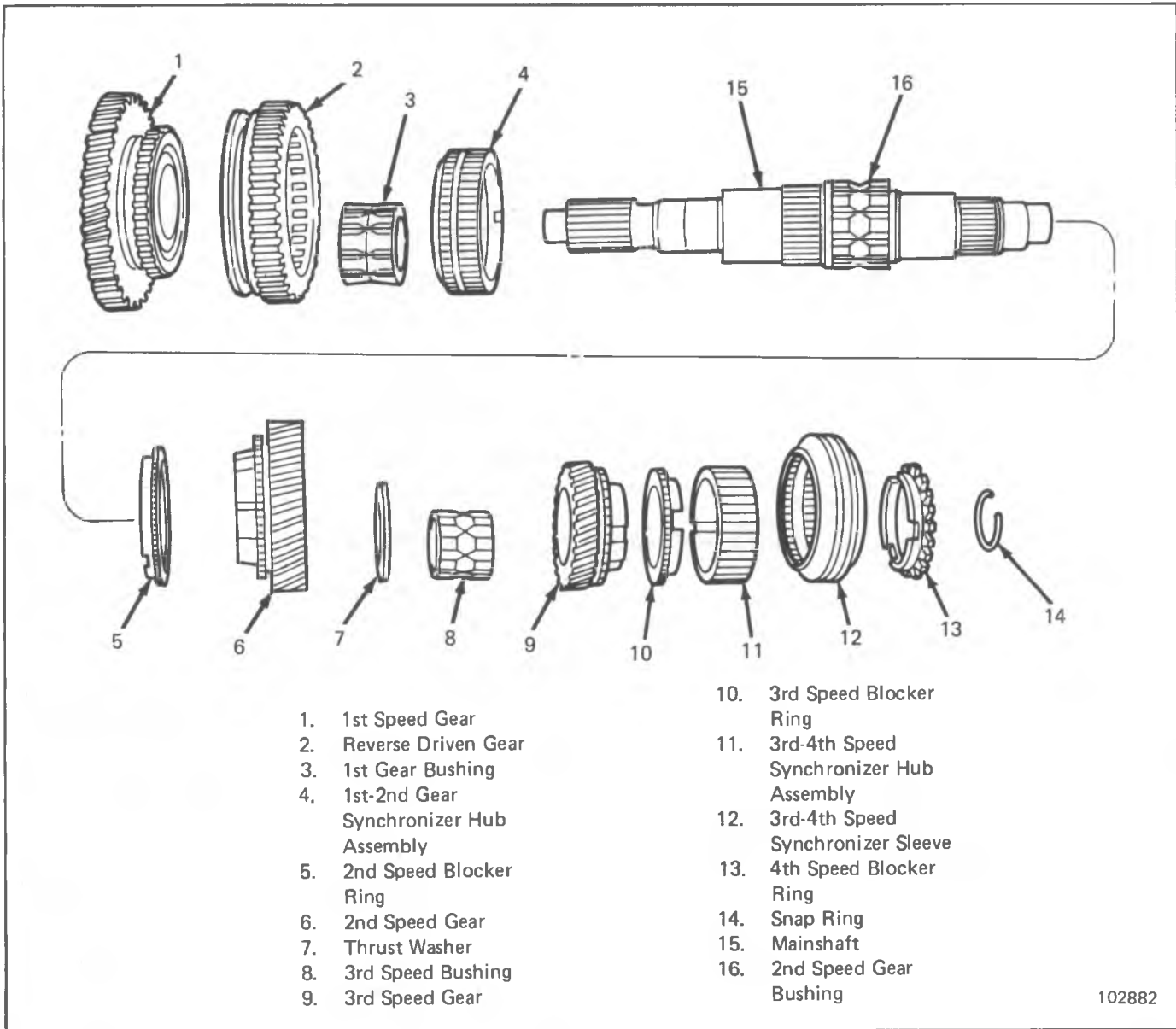

Fig. 7B4-10--Mainshaft Assembly

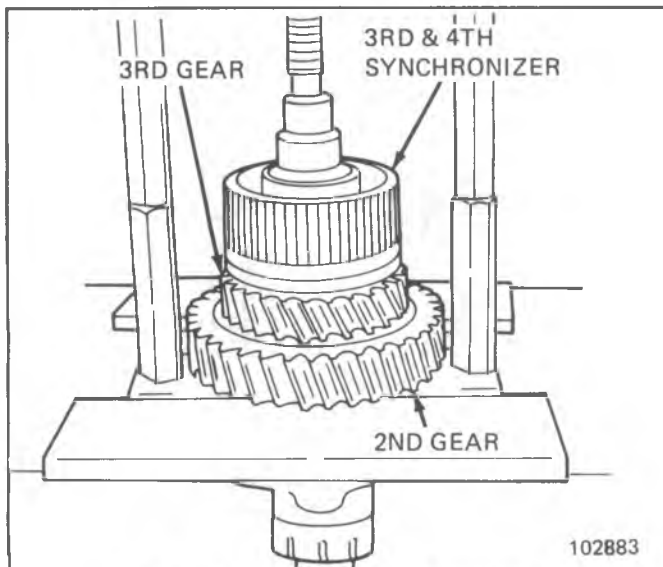

Fig. 7B4-11--Disassembly of Mainshaft

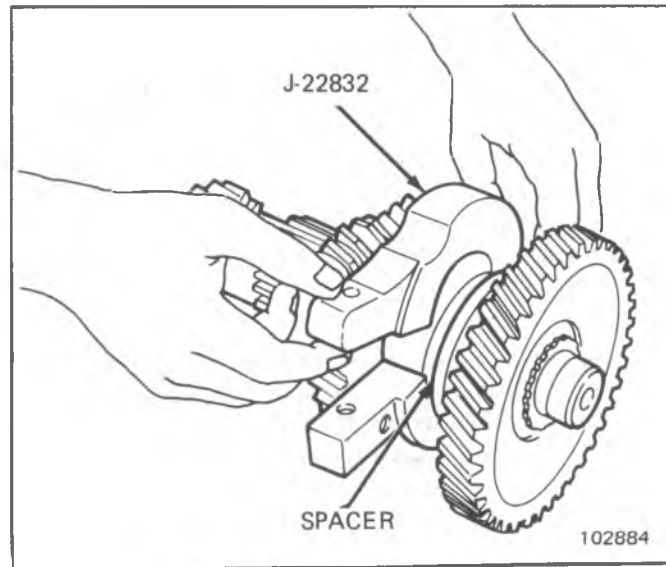

Fig. 7B4-12--Positioning Tool J-22832

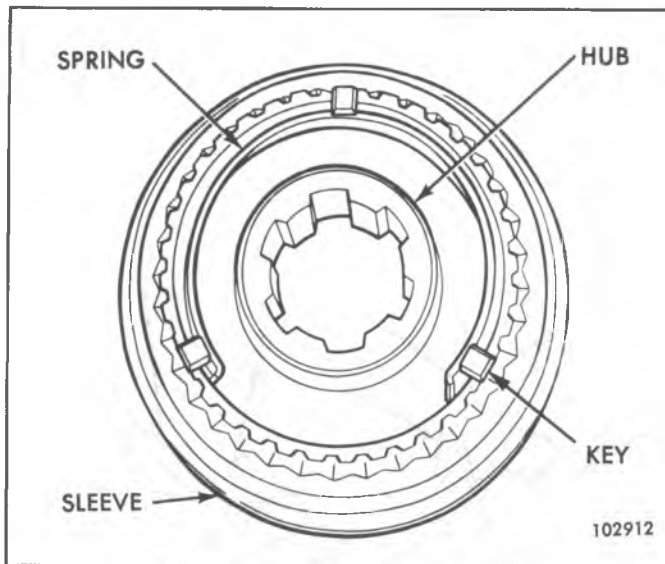

Fig. 7B4-13--Synchronizer Assembly

### Gears

1. Inspect all gears for excessive wear, chips or cracks and replace any that are worn or damaged.
2. Check clutch sleeves to see that they slide freely on their hubs.

### REPAIRS

#### Synchronizer Keys and Springs

##### Replacement

The synchronizer hubs and sliding sleeves are a selected assembly and should be kept together as originally assembled, but the keys and two springs may be replaced if worn or broken.

1. If relation of hub and sleeve are not already marked, mark for assembly purposes.
2. Push the hub from the sliding sleeve; the keys will fall free and the springs may be easily removed.
3. Place the two springs in position (one on each side

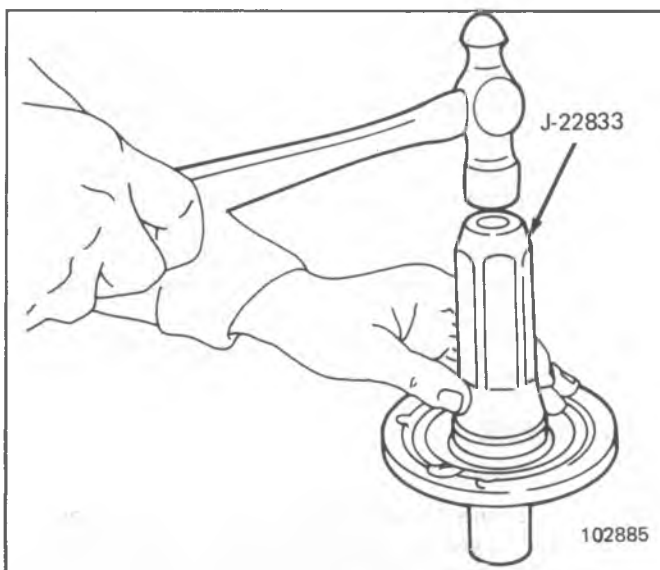

Fig. 7B4-14--Installing Bearing Retainer Oil Seal

of hub), so all three keys are engaged by both springs (Fig. 7B4-13).

Place the keys in position and while holding them in place, slide the sleeve onto the hub, aligning the marks made before disassembly.

#### Drive Gear Bearing Retainer Oil Seal (Fig. 7B4-14)

##### Replacement

1. Remove retainer and oil seal assembly and gasket.
2. Pry oil seal out of retainer.
3. Install new seal on Tool J-22833 with lip of seal toward flange of tool.
4. Support front surface of retainer in press, start seal and tool in retainer bore and drive seal into retainer until flange of tool bottoms on retainer (Fig. 7B4-14).
5. Install new gasket on retainer and install retainer on transmission case (when assembling transmission).

#### TRANSMISSION COVER (Fig. 7B4-15, 16)

##### Disassembly

1. Using a small punch, drive out pins retaining 1st-2nd and 3rd-4th shifter forks to shifter shafts and also drive out expansion plugs.

The pin retaining the third and fourth shifter fork to the shaft must be removed, and the shifter fork removed from the cover before the reverse shifter head pin can be removed.

2. With shifter shafts in neutral position, drive shafts out of cover and shifter forks.

**NOTICE:** Exercise care so shaft detent balls, springs and innerlock pin located in the cover are not lost as the shifter shafts are removed.

3. Drive out pin holding reverse shifter head and drive out the shaft.

**NOTICE:** Exercise care during shaft removal since detent balls are under spring tension in the rear rail boss holes.

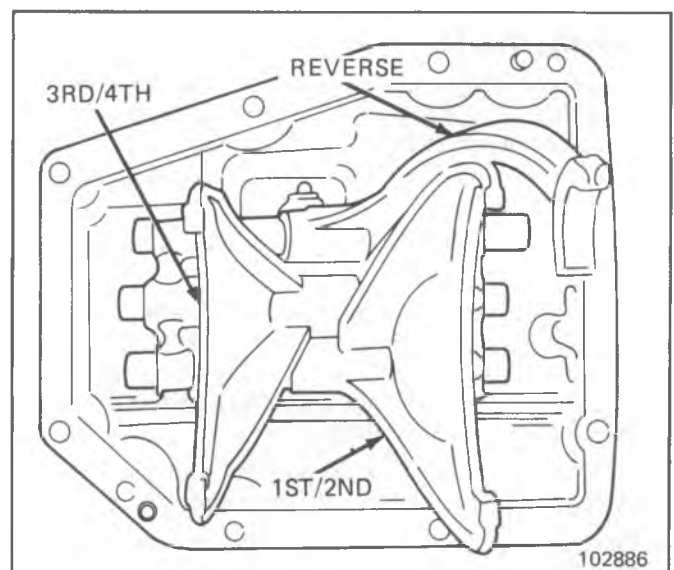
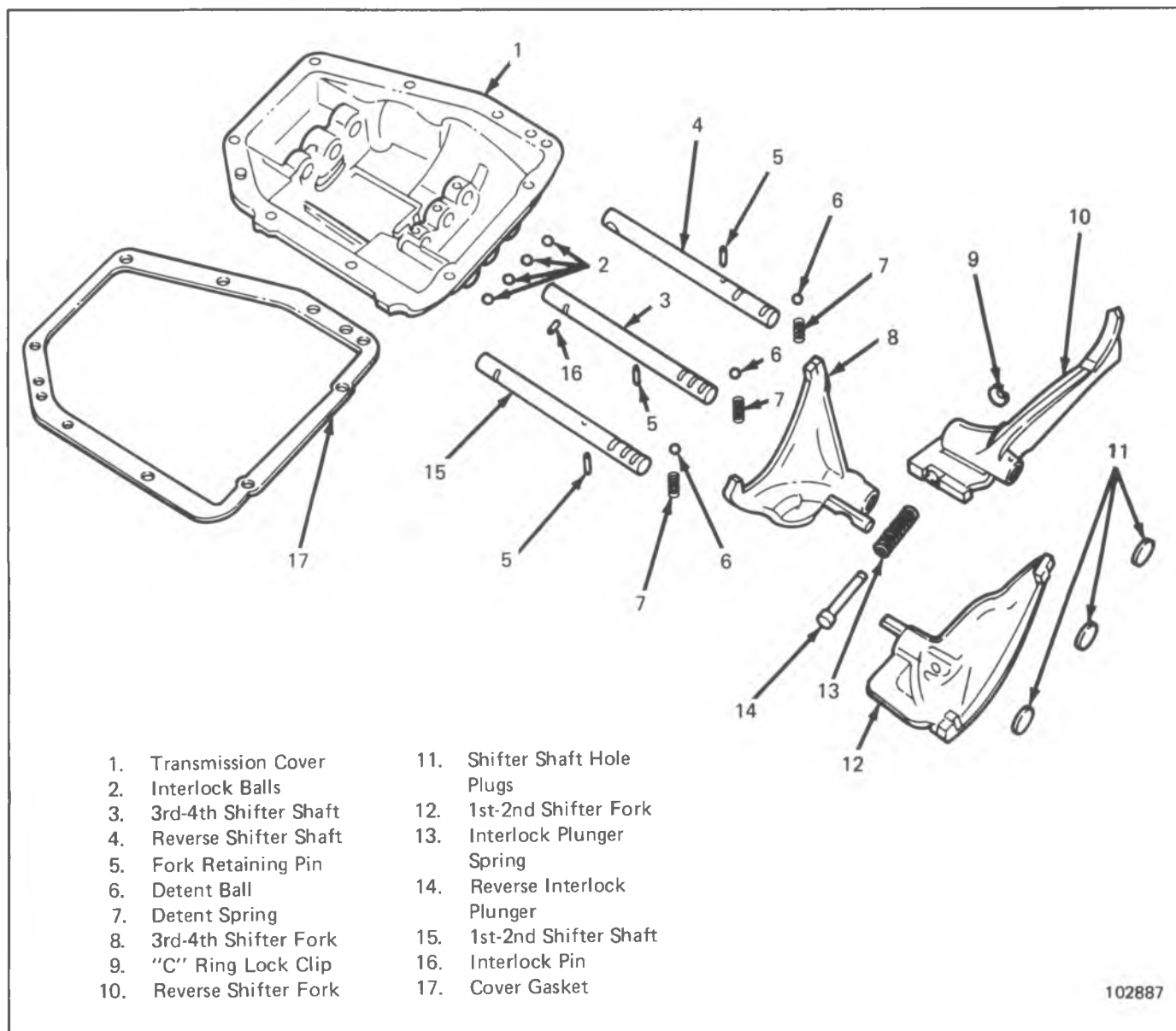

Fig. 7B4-15--Cover Assembly





102887

Fig. 7B4-16--Cover Assembly Exploded View

**Assembly (Fig. 7B4-16)**

1. In reassembling the cover, care must be used in installing the shifter shafts. They should be installed in the order shown in Fig. 7B4-15, namely, reverse, 3rd-4th, and 1st-2nd. Fig. 7B4-16 illustrates the difference in the shafts.
2. Place fork detent ball springs and balls in position in holes in cover.
3. Start shifter shafts into cover, depress detent balls with small punch and push shafts on over balls. (See Fig. 7B4-17). Hold reverse fork in position and push shaft through yoke. Install split pin in fork and shaft, then push fork in neutral position.
4. Hold 3rd and 4th fork in position and push shaft through yoke, but not through front support bore.
5. Place two interlock balls in cross-bore in front support boss between reverse and 3rd and 4th shifter shaft. Install the interlock pin in the 3rd and 4th shifter shaft hole. Apply grease to hold in place. Push 3rd and 4th

shaft through fork and cover bore, keeping both balls and pin in position between shafts until retaining holes line up in fork and shaft. Install retaining pin and move to neutral position.

6. Place two interlock balls between the 1st and 2nd shifter shaft and 3rd and 4th shifter shaft in the cross-bore of the front support boss. Hold 1st and 2nd fork in position and push shaft through cover bore in fork until retainer hole and fork line up with hole in shaft. Install retainer pin and move to neutral position.
7. Install new shifter shaft hole expansion plugs and expand in place.

**COUNTERGEAR****Assembly**

1. Position 3rd speed countergear and shaft on arbor press and press the gear onto the shaft. Install gear with the machined surface to mate with the snap ring, toward the front (rear side of the gear is undercut). The 3rd speed gear must be installed with a load of 1500 lb. If

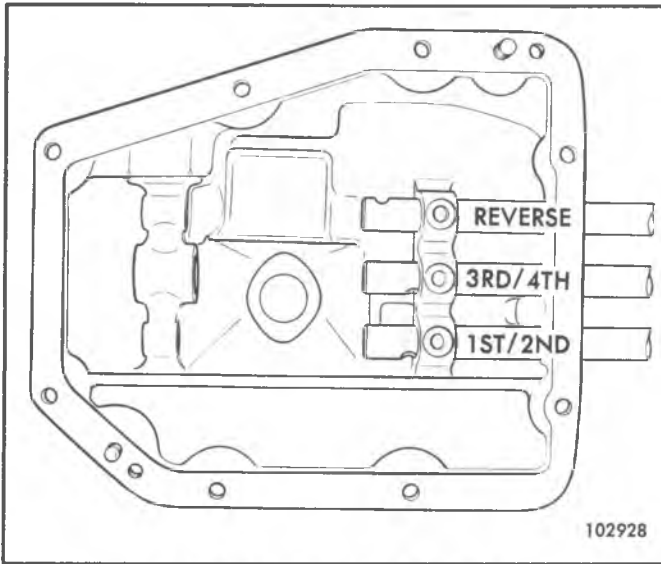

Fig. 7B4-17--Shifter Shaft Installation

the gear requires less than 1500 lbs., another gear must be selected for installation. The press fit is required for proper operation.

2. Install spacer, then press front gear on countershaft and using snap ring pliers, install snap ring.
3. Install new clutch countergear rear retaining ring using Tool J-22830-A, J-22873 and snap ring pliers as follows:

Install Tool J-22830-A on end of shaft and position snap ring on tool (Fig. 7B4-18). Using Tool J-22873, push down on snap ring until it engages groove on shaft. Using snap ring pliers, carefully expand ring until it just slides onto splines, then push ring down shaft until it engages groove on shaft.

**NOTICE:** Do not over stress snap ring or damage may occur.

4. Position clutch countergear and spacer on shaft and press countergear onto shaft against snap ring using

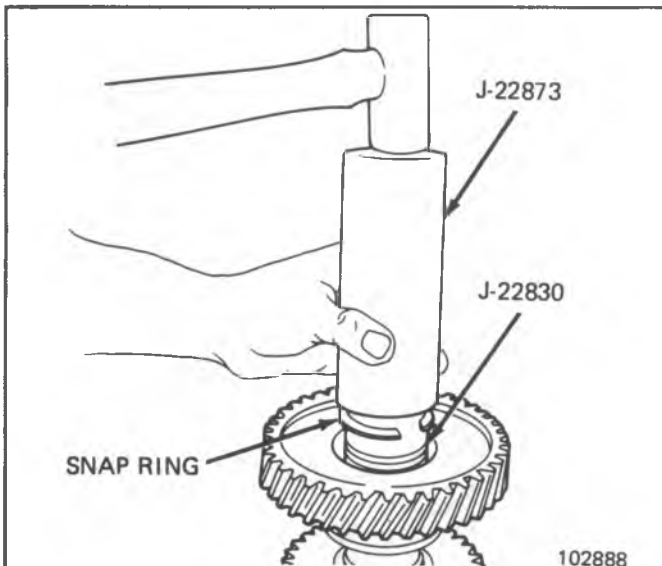

Fig. 7B4-18--Counter Gear Snap Ring

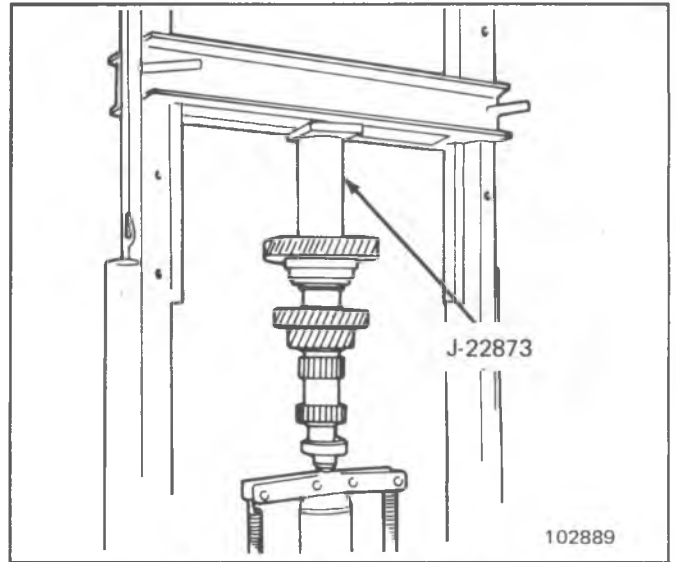

Fig. 7B4-19--Clutch Countergear

Tool J-22873, (Fig. 7B4-19). Countergear is a slip fit and pressing may not be required.

5. Install clutch countergear thrust washer and front retaining ring using Tool J-22830-A and J-22873 (Fig. 7B4-18).

**NOTICE:** Do not over stress snap ring, or damage may occur. Ring should be tight in groove without side play.

### DRIVE GEAR (Fig. 7B4-20)

#### Assembly

1. Press bearing and new oil slinger onto drive gear shaft using Tool J-22872 (Fig. 7B4-20). Slinger should be located flush with bearing shoulder on drive gear. See Figure 7B4-21 for direction of slinger installation.

**NOTICE:** Exercise care to prevent distortion of the oil slinger.

2. Install snap ring to secure bearing on drive gear shaft.

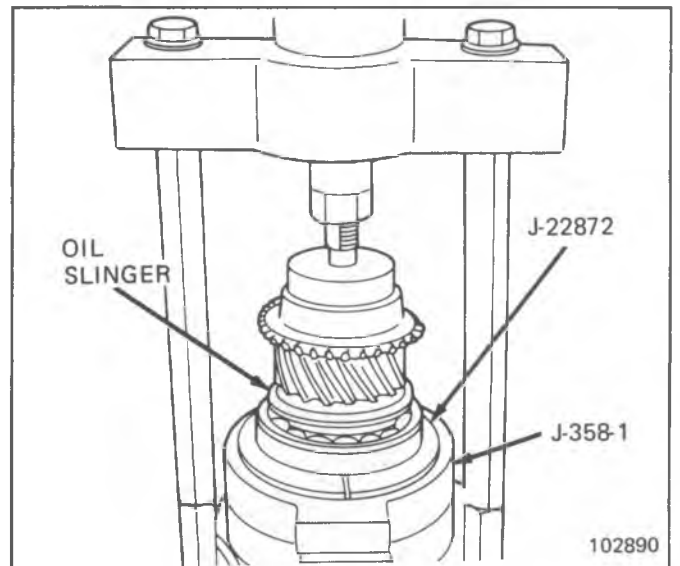

Fig. 7B4-20--Drive Gear Bearing

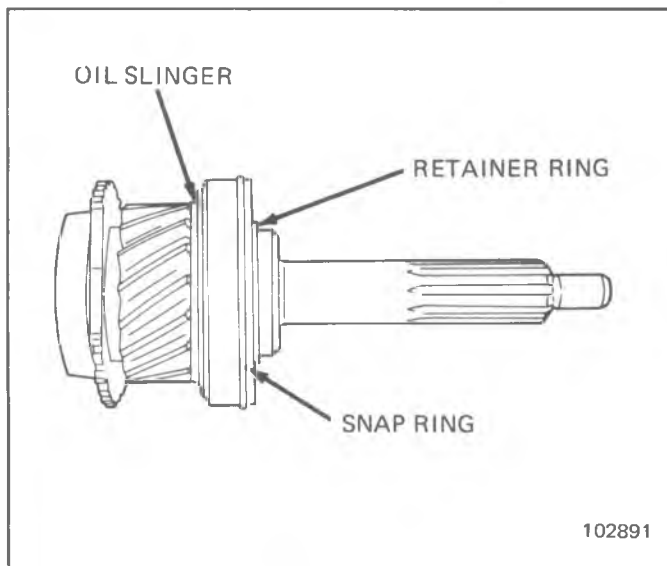

Fig. 7B4-21--Drive Gear Assembly

3. Install bearing retainer ring in groove on O.D. of bearing. The bearing must turn freely, after it is installed on the shaft.
4. Install snap ring on I.D. of mainshaft pilot bearing bore in clutch gear (if previously removed).
5. Apply a small amount of grease to bearing surface in shaft recess, install transmission mainshaft pilot roller bearings (17) and install roller bearing retainer (Fig. 7B4-22).

This roller bearing retainer holds bearing in position and in final transmission assembly is pushed forward into recess by mainshaft pilot.

**MAINSHAFT**

**Assembly**

1. Using Tool J-22873 press 2nd speed bushing onto mainshaft until it bottoms against shoulder (Fig. 7B4-23). Lubricate bushing with E.P. oil before pressing.

**NOTICE:** 1st, 2nd and 3rd speed gear bushings are

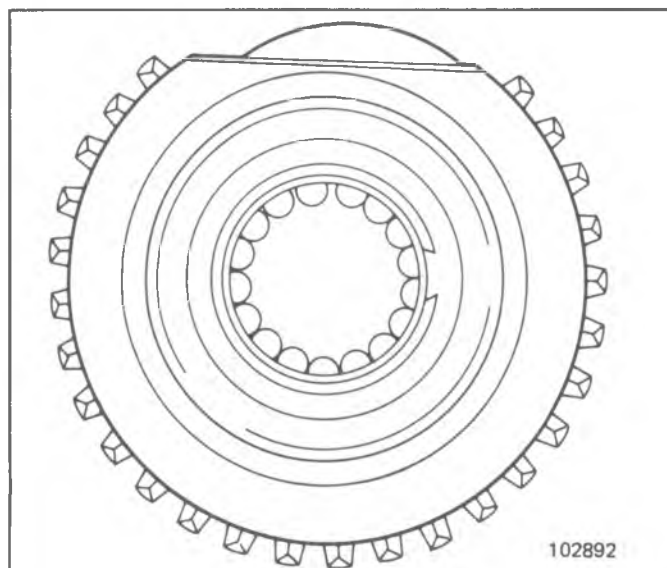

Fig. 7B4-22--Pilot Roller Bearing

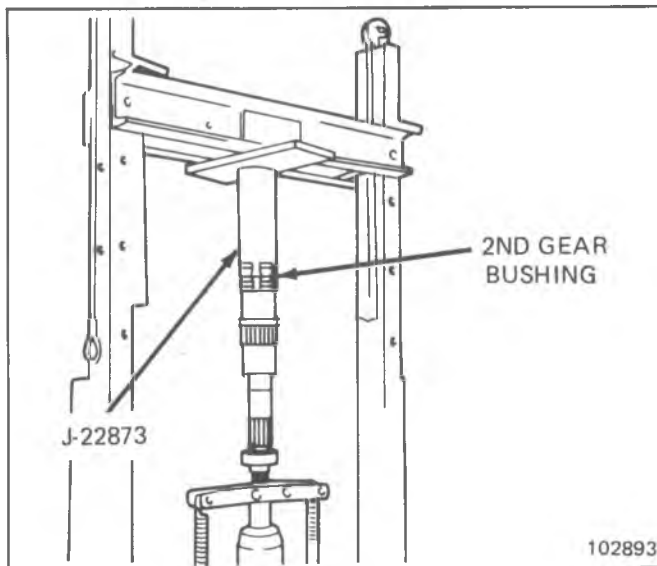

Fig. 7B4-23--2nd Speed Gear Bushing

- sintered iron, exercise care when installing or damage may occur.
2. Press 1st and 2nd speed synchronizer hub onto mainshaft until it bottoms against shoulder with annulus toward rear of shaft.
  3. Install 1st and 2nd synchronizer keys and springs (if previously removed).
  4. Using Tool J-22873 press 1st speed gear bushing onto mainshaft until it bottoms against hub (Fig. 7B4-24). Lubricate all bushings with E.P. oil before

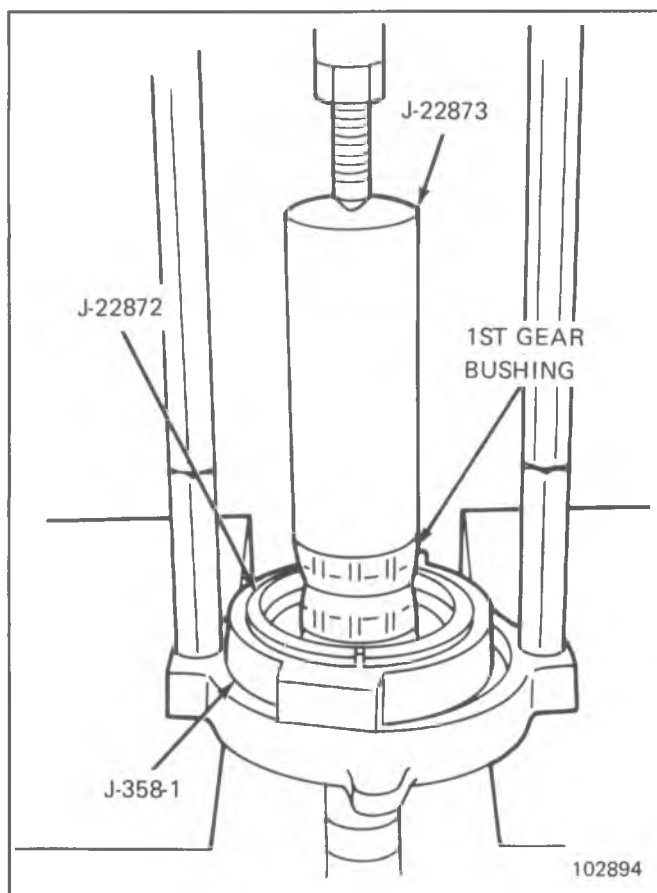

Fig. 7B4-24--1st Speed Gear Bushing

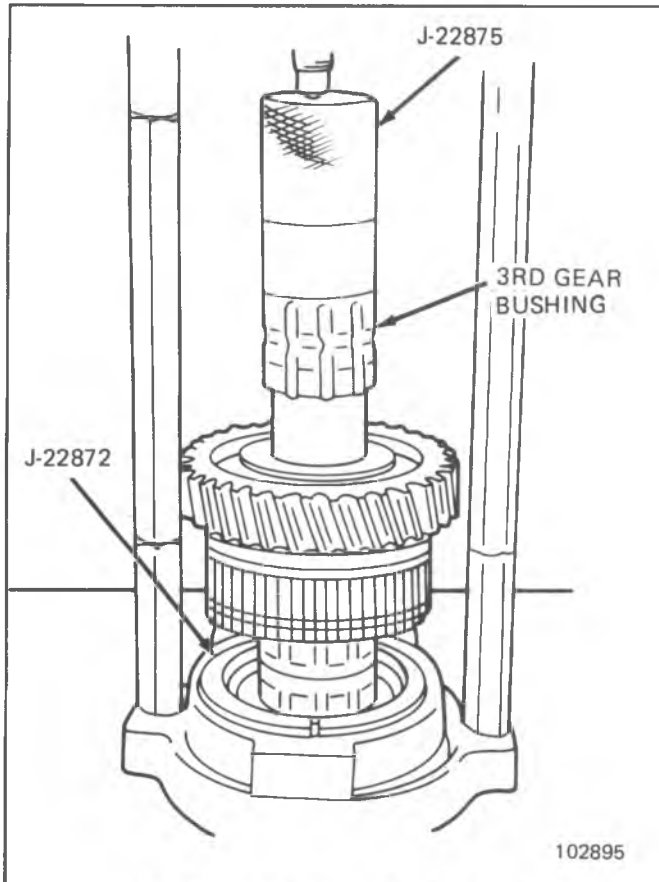

Fig. 7B4-25--3rd Speed Gear Bushing

installation of gears.

5. Install synchronizer blocker ring and 2nd speed gear onto mainshaft and against synchronizer hub. Index synchronizer key slots with keys in synchronizer hub.
6. Install 3rd speed gear thrust washer onto mainshaft with tang on thrust washer in slot on shaft and against 2nd speed gear bushing. Then press 3rd speed gear bushing onto mainshaft using Tool J-22875 until it bottoms against thrust washer (Fig. 7B4-25).

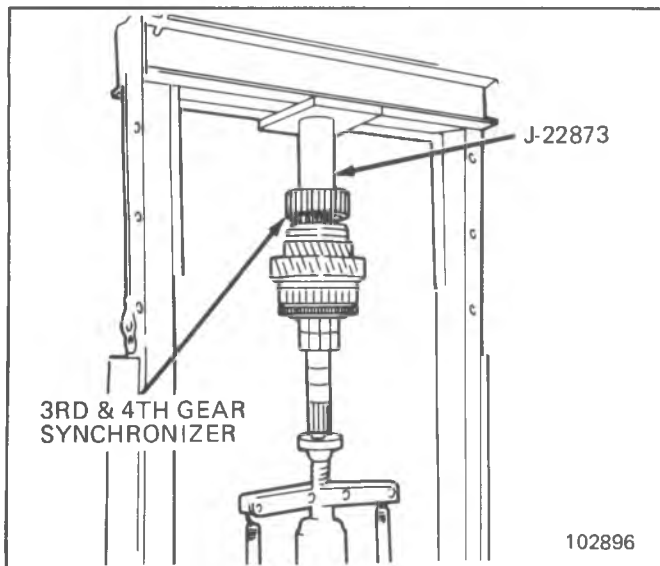

Fig. 7B4-26--3rd and 4th Gear Synchronizer

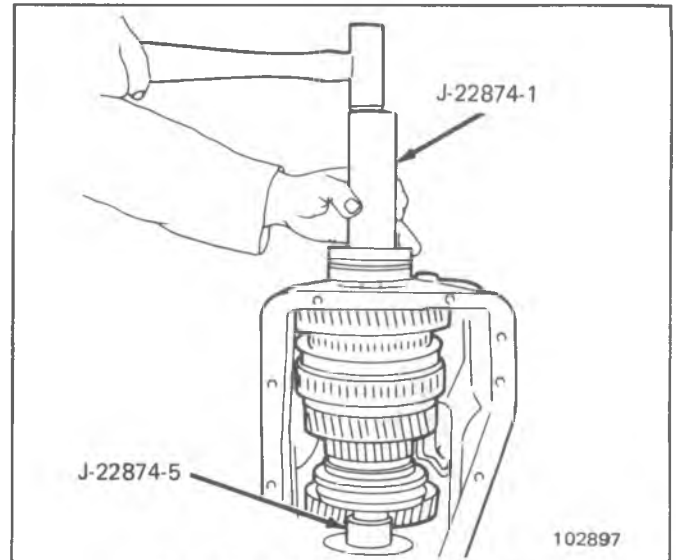

Fig. 7B4-27--Mainshaft Rear Bearing

7. Install 3rd speed gear synchronizer blocker ring and 3rd speed gear onto mainshaft, against 3rd speed gear thrust washer.
8. Index synchronizer ring key slots with synchronizer assembly keys and press 3rd and 4th synchronizer assembly onto mainshaft using Tool J-22875 and against 3rd speed gear bushing thrust face toward 3rd speed gear (Fig. 7B4-26). Retain synchronizer assembly with snap ring.
9. Install reverse driven gear with fork groove toward rear.
10. Install 1st speed gear onto mainshaft and against 1st and 2nd synchronizer hub. Install 1st speed gear thrust washer.

## TRANSMISSION

### Assembly

1. Lower the countergear into the case until it rests on bottom of case.
2. Place reverse idler gear in transmission case with

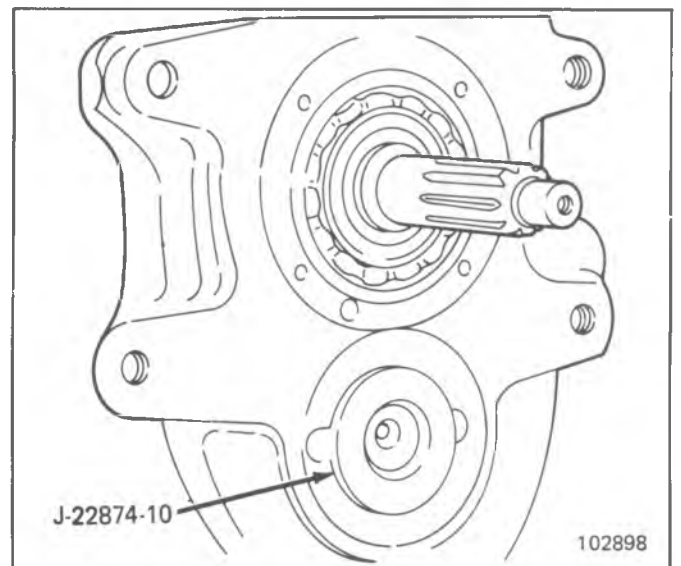

Fig. 7B4-28--Countergear Front Support Tool

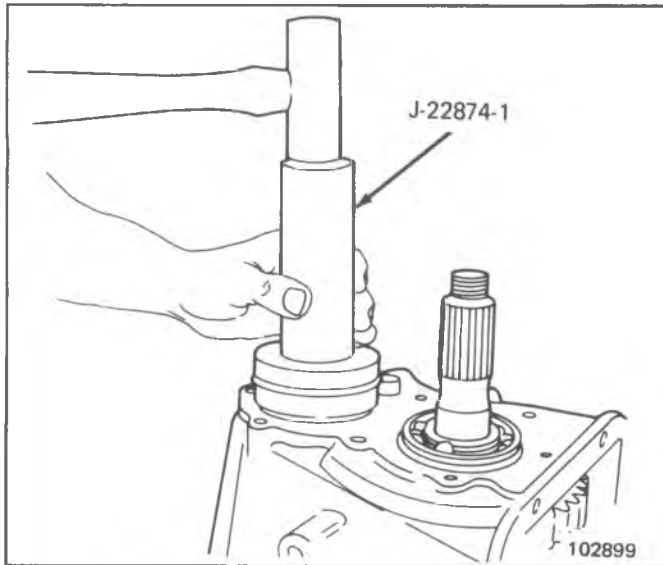

Fig. 7B4-29--Countergear Rear Bearing

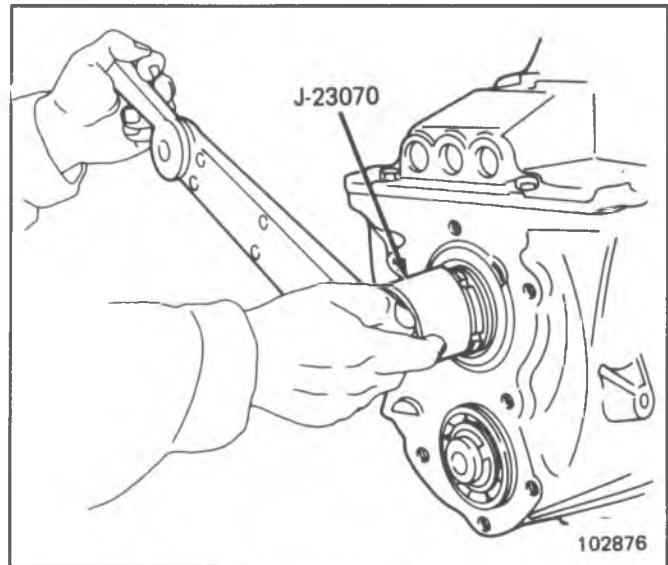

Fig. 7B4-30--Mainshaft Rear Bearing Lock Nut

gear teeth toward the front. Install idler gear shaft from rear to front, being carefully to have slot in end of shaft in facing down. Shaft slot face must be at least flush with case.

3. Install mainshaft assembly into case with rear of shaft protruding out rear bearing hole in case. Position Tool J-22874 in clutch gear case opening and engaging front mainshaft (Fig. 7B4-27). Rotate case onto front end.  
Install 1st speed gear thrust washer on shaft, if not previously installed.
4. Install snap ring on bearing O.D. and position rear mainshaft bearing on shaft. Using Tool J-22874-1 drive bearing onto shaft and into case (Fig. 7B4-27). Rotate case and remove Tool J-22874-5.
5. Install synchronizer cone on pilot end of mainshaft and slide rearward to clutch hub. Make sure three cut out sections of 4th speed synchronizer cone align with three clutch keys in clutch assembly.
6. Install snap ring on drive gear bearing O.D. Index cut out portion of drive gear teeth to obtain clearance over countershaft drive gear teeth, and install clutch gear assembly onto case. Raise mainshaft to get clutch gear started and tap bearing outer race with plastic tip hammer.
7. Install drive gear bearing retainer using a new gasket, install bolts and torque to specifications.

8. Install appropriate tool in countergear front bearing opening in case to support countergear and rotate case onto front end. (Fig. 7B4-28).
9. Install snap ring on countergear rear bearing O.D. position, bearing on countergear and using Tool J-22874-1, drive bearing into place (Fig. 7B4-29). Rotate case, install snap ring on countershaft at rear bearing and then remove Tool J-22874-1.
10. Tap countergear front bearing assembly into case.
11. Install countergear front bearing cap and new gasket. Torque screws to specifications.
12. Slide speedometer drive gear over mainshaft to bearing.
13. Install rear bearing retainer with new gasket. Be sure snap ring ends are in lube slot and cut out in bearing retainer. Install bolts and torque to specifications. Install brake backing plate assembly on models equipped with propeller shaft brake.  
On models equipped with 4-wheel drive, install rear lock nut and washer using Tool J-23070 (Fig. 7B4-30). Torque lock nut to specifications and bend washer tangs to fit slots in nut.
14. Install parking brake drum and/or universal joint flange. Apply light coat of oil to seal surface.
15. Lock transmission in two gears at once. Install universal joint flange locknut and torque to specifications.

## SPECIFICATIONS

|  |        |            |
|--|--------|------------|
| Drive Gear Bearing Retainer to Case Bolts      | 32 N·m | 25 ft. lb. |
| Cover to Case Bolts                            | 27 N·m | 20 ft. lb. |
| Extension and Retainer to Case Bolts – (Upper) | 27 N·m | 20 ft. lb. |
| Extension and Retainer to Case Bolts – (Lower) | 40 N·m | 30 ft. lb. |
| Lubrication Filler Plug                        | 40 N·m | 30 ft. lb. |
| Shift Lever to Shifter Shaft Nut               | 27 N·m | 20 ft. lb. |
| Crossmember to Frame Nuts                      | 75 N·m | 55 ft. lb. |
| Crossmember to Mount Bolts                     | 55 N·m | 40 ft. lb. |

## SPECIAL TOOLS

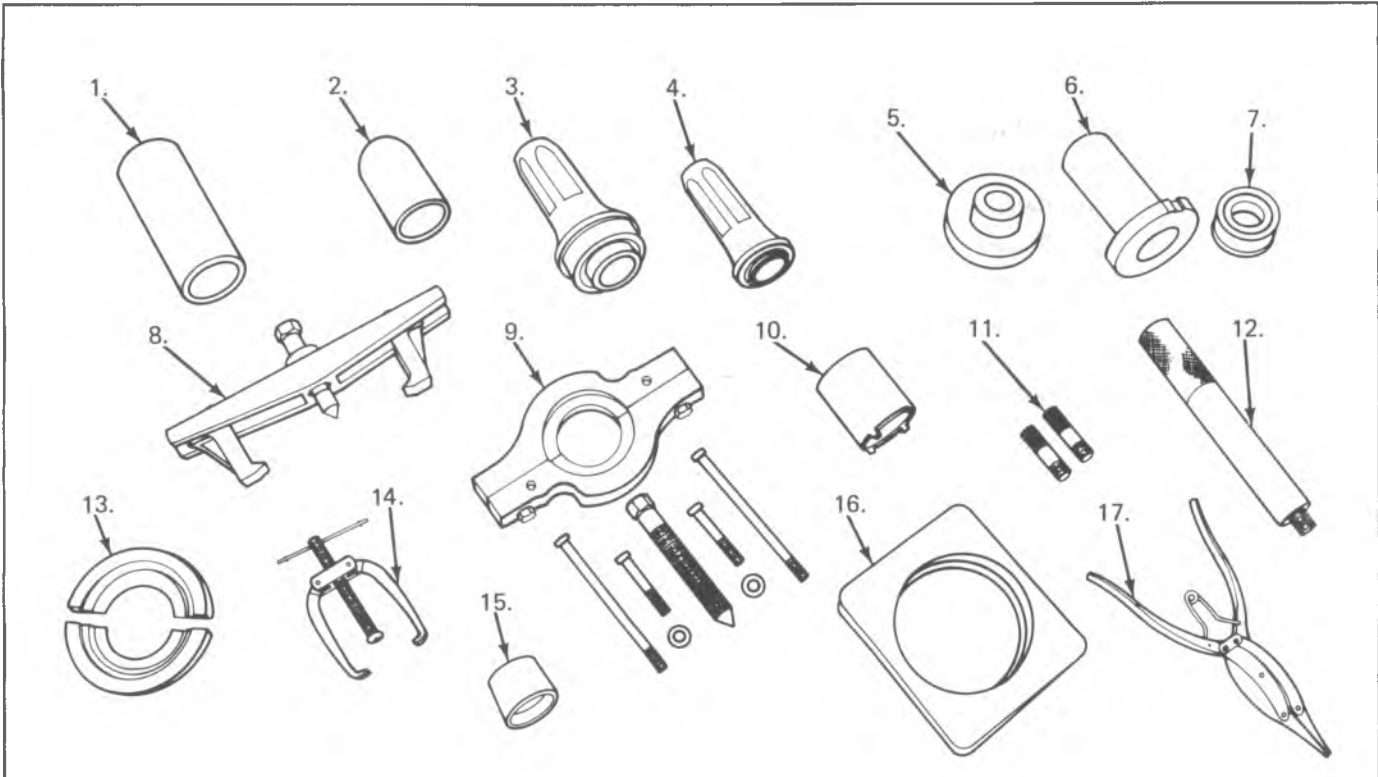

- |     |            |                                       |
|-----|------------|---------------------------------------|
| 1.  | J-22873    | 2nd Speed Bushing Installer           |
| 2.  | J-22875    | 3rd Speed Bushing Installer           |
| 3.  | J-22834    | Rear Retainer Seal Installer          |
| 4.  | J-22833    | Front Bearing Retainer Seal Installer |
| 5.  | J-22874-1  | Mainshaft Rearing Bearing Installer   |
| 6.  | J-22874-5  | Mainshaft Rearing Bearing Installer   |
| 7.  | J-22874-10 | Countergear Front Support             |
| 8.  | J-8433     | Bearing Puller                        |
| 9.  | J-22832-01 | Countergear Rear Bearing Remover      |
| 10. | J-23070    | Mainshaft Bearing Locknut Installer   |
| 11. | J-1126     | Transmission Guide Pins               |
| 12. | J-8092     | Driver Handle                         |
| 13. | J-22872    | Driver Gear Bearing Remover/Installer |
| 14. | J-28509    | Countergear Front Bearing Remover     |
| 15. | J-22830-A  | Snap Ring Installer                   |
| 16. | J-358-1    | Press Plate Holder                    |
| 17. | J-8059     | Snap Ring Pliers                      |

# CLUTCH

## CONTENTS

|                                      |    |                                 |    |
|--------------------------------------|----|---------------------------------|----|
| General Description.....             | 1  | Pedal .....                     | 12 |
| Clutch Systems.....                  | 1  | Cross-Shaft .....               | 13 |
| Diaphragm Type.....                  | 1  | Unit Repair.....                | 14 |
| Coil Spring Type.....                | 3  | Diaphragm Type.....             | 14 |
| Clutch Controls .....                | 4  | Disassembly .....               | 14 |
| Maintenance and Adjustments .....    | 8  | Inspection.....                 | 14 |
| Inspection.....                      | 8  | Assembly.....                   | 14 |
| Free Pedal Adjustment.....           | 8  | Pilot Bearing Replacement ..... | 14 |
| Diagnosis.....                       | 10 | Coil Spring Type .....          | 15 |
| On Vehicle Service                   |    | Disassembly .....               | 15 |
| Preliminary Inspection .....         | 11 | Inspection.....                 | 15 |
| Clutch Disc and Pressure Plate ..... | 11 | Assembly.....                   | 15 |
| Diaphragm Type.....                  | 11 | Adjusting Levers.....           | 16 |
| Coil Spring Type .....               | 11 | Special Tools.....              | 18 |

## GENERAL DESCRIPTION

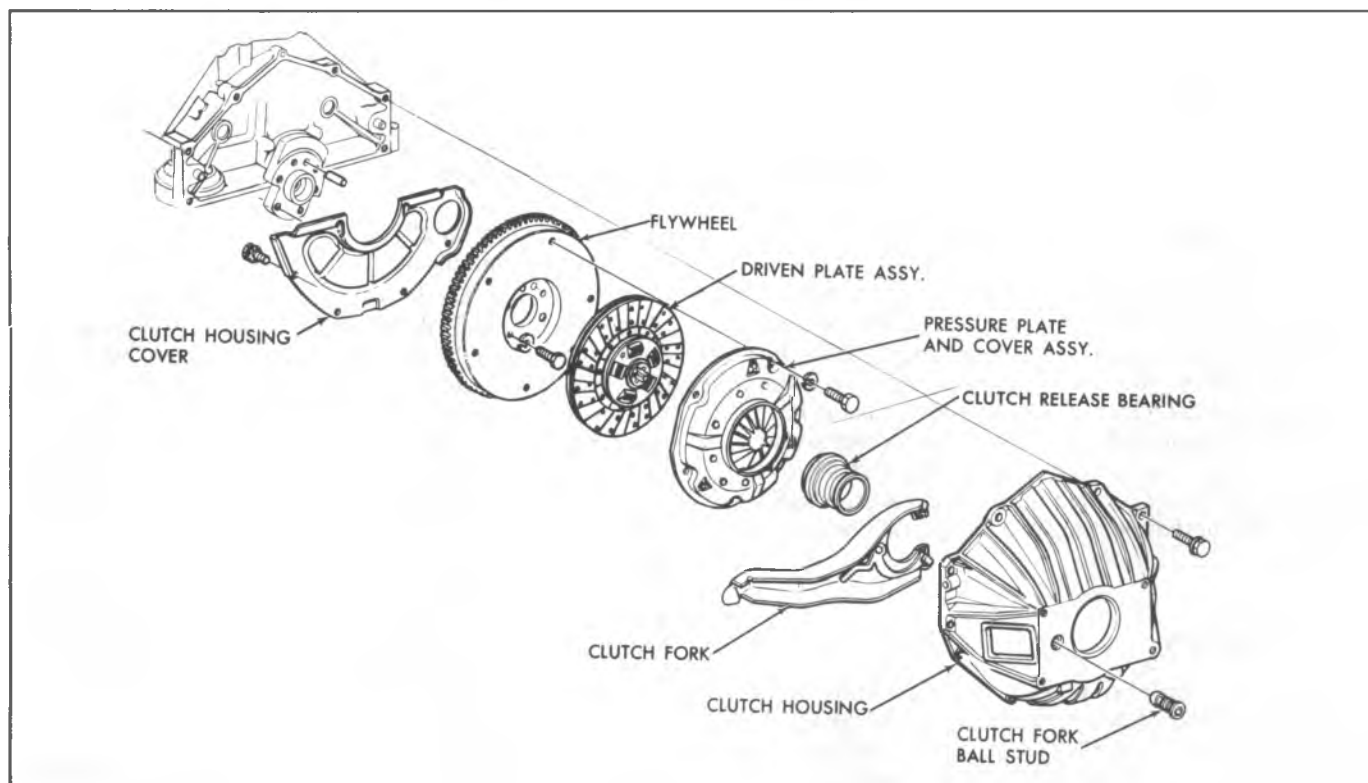

Fig. 7C-1--Clutch System Components

## CLUTCH SYSTEMS

### DIAPHRAGM SPRING CLUTCH

#### Principal Components

The principal parts of a diaphragm-type clutch system are: the driving members, attached to the engine and

turning with it; the driven members attached to the transmission and turning with it; the operating members which include the spring or springs and the linkage required to apply and release the pressure which holds the driving and driven members in contact with each other. Fig. 7C-1 shows a clutch cutaway so operating members can be seen.



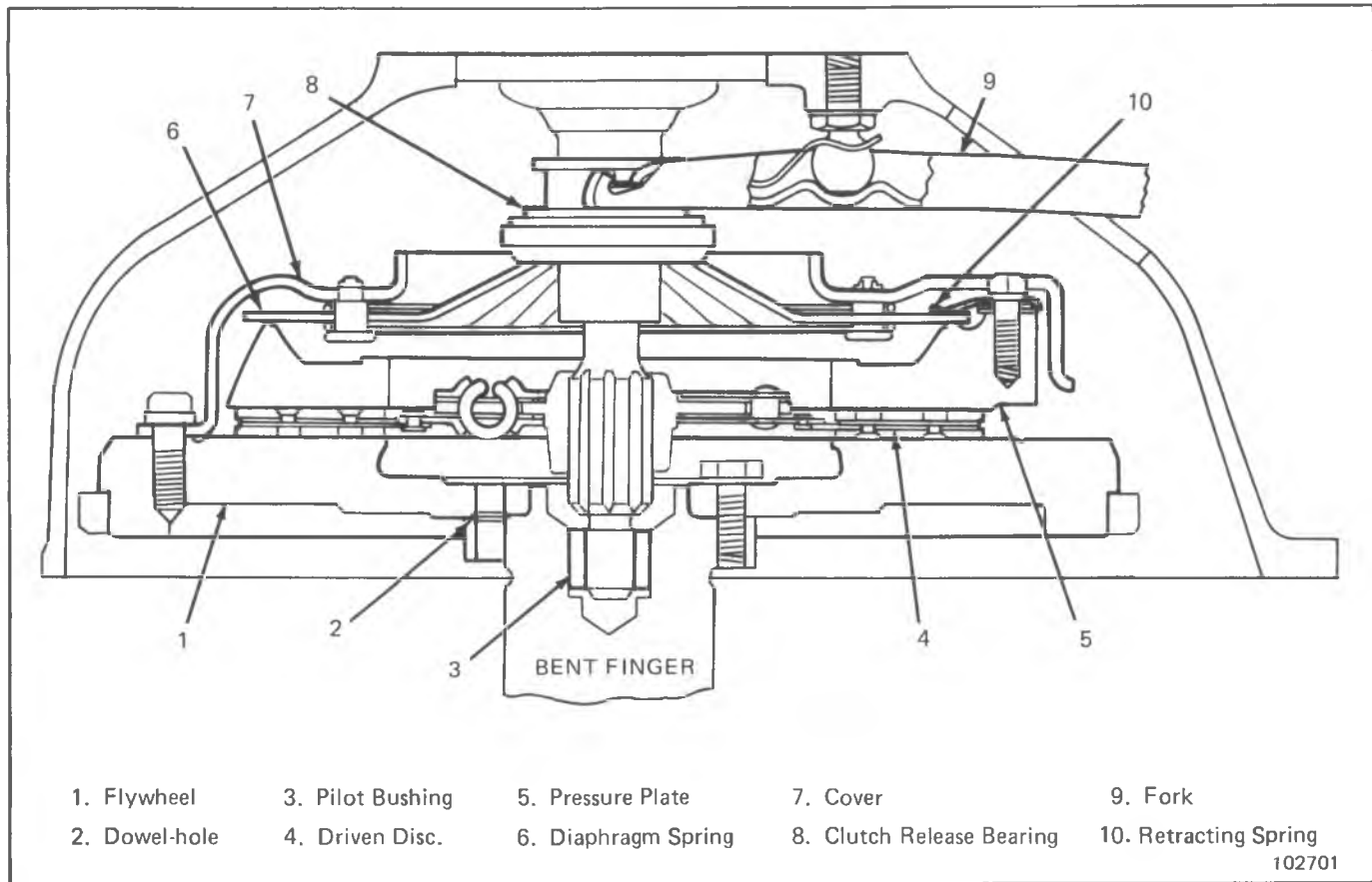

Fig. 7C-2--Cross-Section View of Diaphragm-Type

### Driving Members

The driving members of a clutch usually consist of two iron plates or flat surfaces machined to a smooth finish. Iron is desirable because it contains enough graphite to provide some lubrication when the driving member is slipping during engagement. One of these surfaces is usually the rear face of the engine flywheel, and the other is a comparatively heavy flat ring with one side machined. This part is known as the pressure plate. It is fitted into a steel cover, which also contains some of the operating members, and is bolted to the flywheel.

### Driven Members

The driven member is the clutch disc with a splined hub which is free to slide lengthwise along the splines of the clutch shaft, but which drives the shaft through these same splines. Grooves on both sides of the clutch disc lining prevent sticking of the plate to the flywheel and pressure plate. Suitable frictional facings are attached to each side of the clutch disc by means of brass rivets. These facings must be heat resistant since friction produces heat. The most commonly used facings are made of cotton and asbestos fibers woven or molded together and impregnated with resin or similar binding agents. Very often, copper wires are woven, or pressed into material to give it additional strength.

In order to make clutch engagement as smooth as possible and eliminate chatter, the steel segments attached to the splined hub are slightly waved, which causes the

contact pressure on the facings to rise gradually as the waved springs flatten out.

The clutch disc is provided with a flexible center to absorb the torsional vibration of the crankshaft which would be transmitted to the power train unless it were eliminated. The flexible center takes the form of steel compression springs placed between the hub and the steel plate. The springs permit the disc to rotate slightly with relation to its hub until the springs are compressed and relative motion stops. Then the disc can rotate slightly backward as the springs decompress. This slight backward and forward rotation permitted by the springs allows the clutch shaft to rotate at a more uniform rate than the crankshaft, thereby eliminating some of the torsional vibration from the crankshaft and preventing the vibration from being carried back through the transmission.

### Operating Members

The driving and driven members are held in contact by spring pressure. This pressure may be exerted by a one-piece conical or diaphragm spring. In the diaphragm design clutch, the clutch release bearing moves forward against the spring fingers forcing the diaphragm spring to pivot around the pivot ring, dishing the fingers toward the flywheel. The outer circumference of the spring now lifts the pressure plate away from the driven disc, through a series of retracting springs placed around the outer circumference of the pressure plate.

The clutch release bearing is a ball-thrust bearing contained in the clutch housing, mounted on a sleeve attached to the front of the transmission case.

The release bearing is moved by the clutch fork to contact the release levers and move the pressure plate to the rear, thus separating the clutch driving members from the driven member when the clutch pedal is depressed by the driver.

A return spring preloads clutch linkage, removing looseness due to wear, keeping the bearing clear of the spring fingers.

The clutch free pedal travel, therefore, will increase with linkage wear and decrease with driven disc wear. The

free travel felt at the clutchpedal is release bearing lash.

**Clutch Spring Operation**

In diaphragm spring type clutches, a diaphragm spring is used instead of coil springs. It is a conical piece of spring steel punched to give it greater flexibility. The diaphragm is positioned between the cover and the pressure plate so that the diaphragm spring is nearly flat when the clutch is in the engaged position. The action of this type of spring is similar to that of the bottom of an ordinary oil can. The pressure of the outer rim of the spring on the pressure plate decreases as the flat position is passed. The outer rim of the diaphragm is secured to the pressure plate and is pivoted on rings approximately 25mm (1 in.) in from the outer edge so that the application of the pressure at the inner section will cause the outer rim to move away from the flywheel and draw the pressure plate away from the clutch disc, releasing or disengaging the clutch. When the pressure is released from the inner section, the oil-can action of the diaphragm causes the inner section to move out, and the movement of the outer rim forces the pressure plate against the clutch disc, thus engaging the clutch.

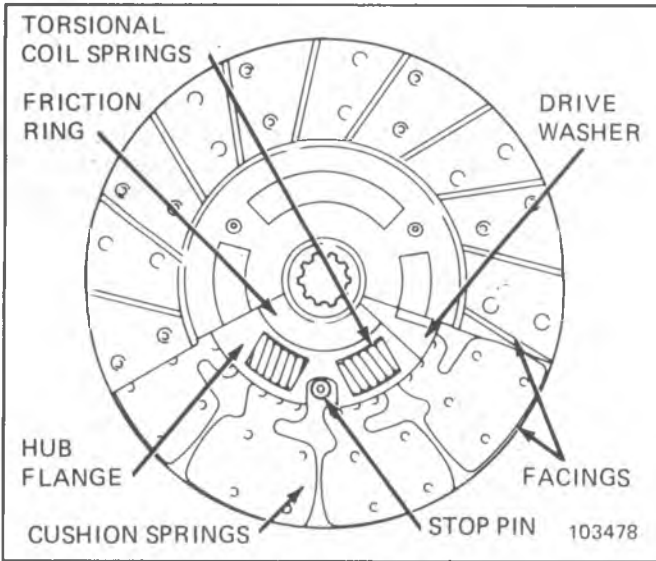

Fig. 7C-3--Clutch Disc

**COIL SPRING CLUTCH**

The coil spring single plate clutch (Fig. 7C-4) is a dry disc type and no adjustment for wear is provided in the clutch itself. An individual adjustment is provided for locating each lever in manufacturing but the adjusting nut is locked in place and should never be disturbed, unless the clutch assembly is dismantled for replacement of parts.

When the clutch pedal is depressed the release bearing is moved toward the flywheel and contacts the inner ends of

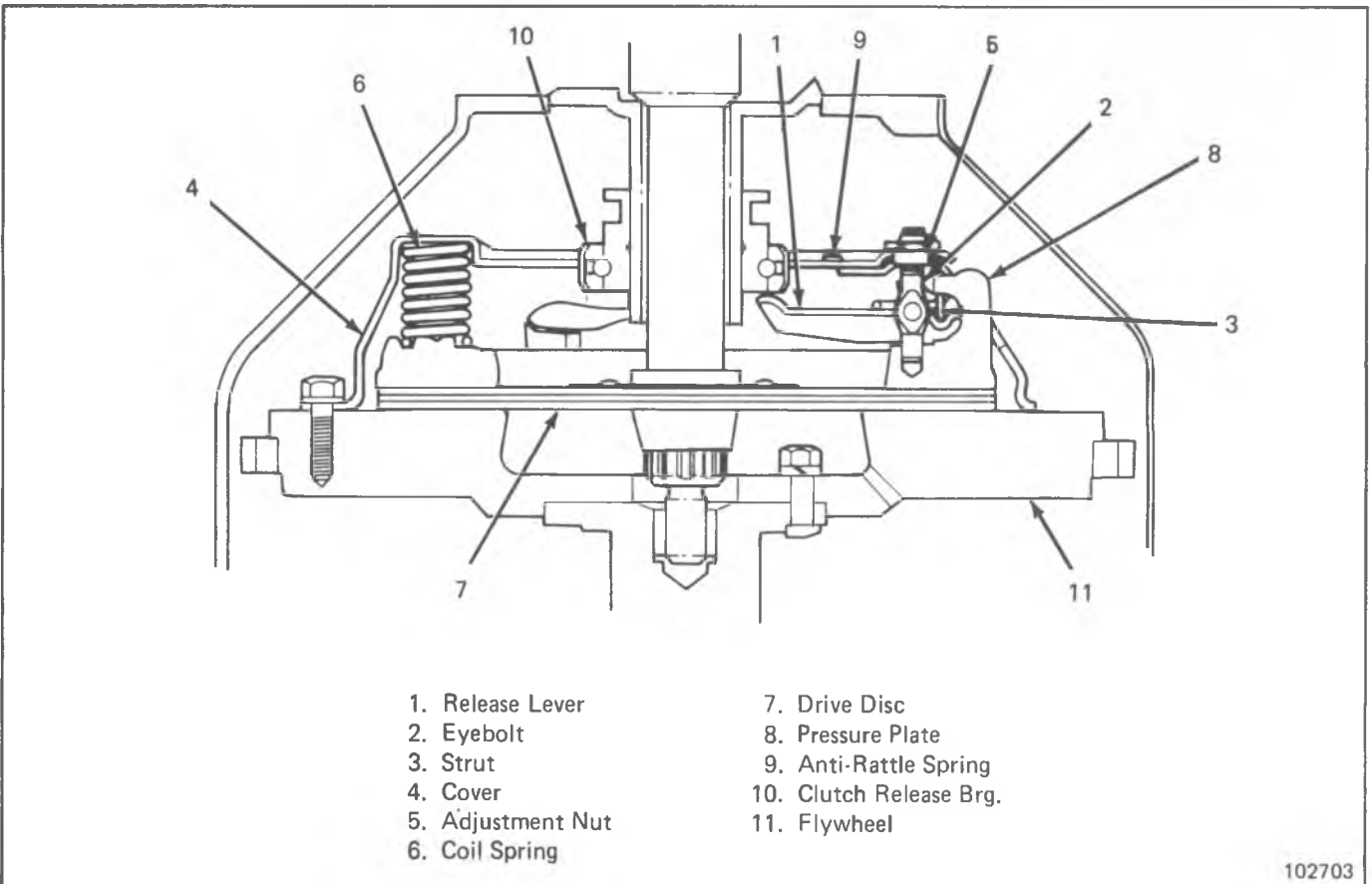

Fig. 7C-4--Cross-Section View of Coil Spring Type

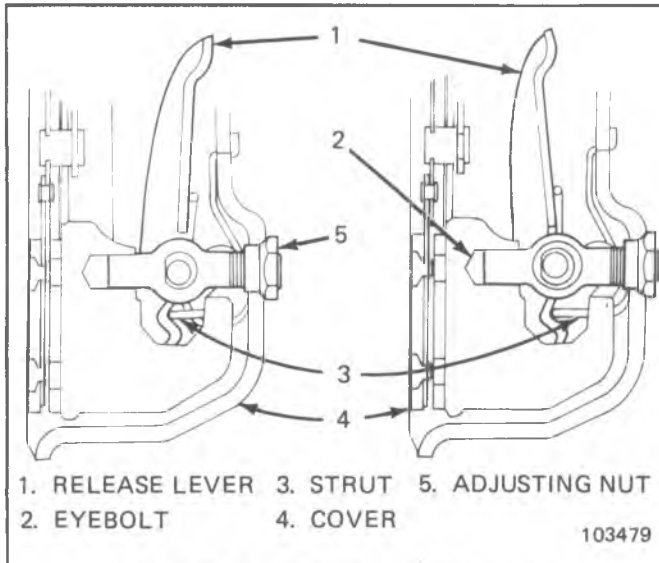

Fig. 7C-5--Release Lever, Coil Spring Type

the release levers, (refer to item 1 in Fig. 7C-5). Each release lever is pivoted on a floating pin which remains stationary in the lever and rolls across a short flat portion of the enlarged hole in the eyebolt (refer to item 2). The outer end of each release lever engages the pressure plate lug by means of a strut (3), which provides knife-edge contact between the outer end of the lever and the lug. The outer ends of the eyebolts extend through holes in the stamped cover (4), and are fitted with adjusting nuts (5) to correctly position the levers.

When the clutch system is fully engaged, the clutch disc is firmly clamped between the flywheel and the pressure plate by the pressure of the springs. When the driver disengages the clutch by depressing the pedal, the release fork is moved on its pivot, and the pressure is applied to the release bearing. The rotating race of the release bearing presses against the clutch release levers and moves them on

their pivot pins. The outer ends of the release levers, being fastened to the cover, move the pressure plate to the rear, compressing the clutch springs and allowing driving members to rotate independently of the driven member. The release fork moves only on its pivot, which contacts the clutch fork ball stud. All parts of the clutch system, except the clutch release bearing and collar, rotate with the flywheel when the clutch is engaged.

When the clutch is disengaged, the release bearing rotates with the flywheel, but the driven plate and the clutch shaft rotate as dictated by the transmission gear range and vehicle speed.

## CLUTCH CONTROLS

The clutch operating controls for C-K trucks (as shown in Fig. 7C-6) are a mechanical type consisting of a pendant type pedal, return spring, pedal push rod, cross-shaft, fork push rod, routed vertically, inside the cab, from the pedal lever down through two boots on the toe pan, to the cross-shaft lever. When the clutch pedal is depressed, the pedal push rod moves rotating the cross-shaft, pushing the fork push rod rearward, and pivoting the clutch fork to move the release bearing against the clutch release fingers and releasing the clutch.

The clutch operating controls for 'G' and 'P' models are a mechanical type similar to the C-K models. On 'G' models (as shown in Fig. 7C-7) a pedal pull rod is routed vertically from the clutch pedal lever down through the toe-panel to the cross-shaft. When the pedal is depressed, the pedal pull rod moves, rotating the cross-shaft, pushing the clutch fork rod rearward and pivoting the clutch fork. This action moves the release bearing against the clutch release fingers, releasing the clutch.

"P" model controls (as shown in Fig. 7C-8) have an upper pull rod connected from the clutch pedal shaft to a bell crank and a lower pull rod from the bell crank to the cross-shaft. When the pedal is depressed, the pull rods are moved rotating the cross-shaft and pushing the clutch fork rearward, thus subsequently activating the clutch release mechanism.

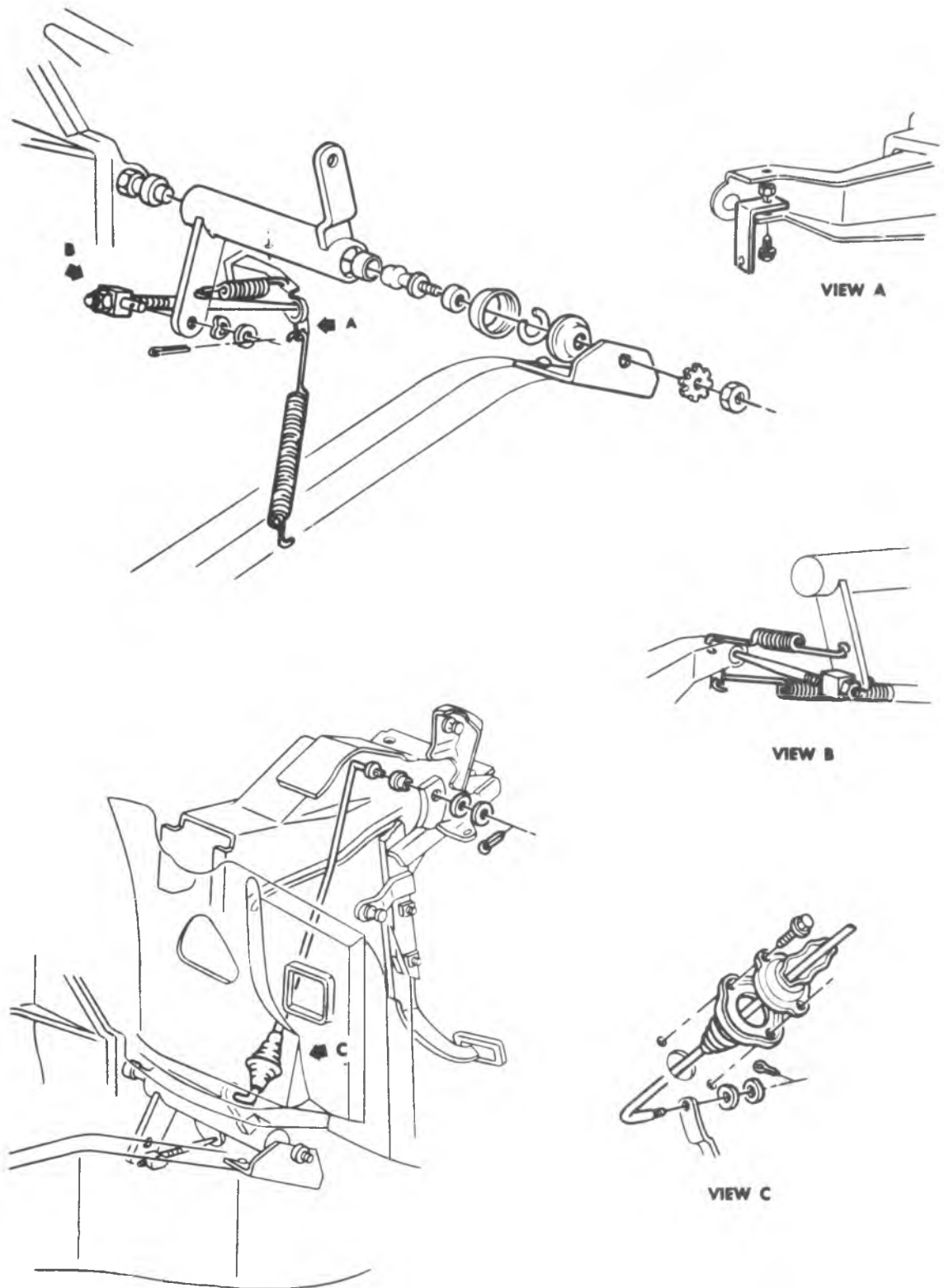

Fig. 7C-6--C-K Truck Clutch Controls

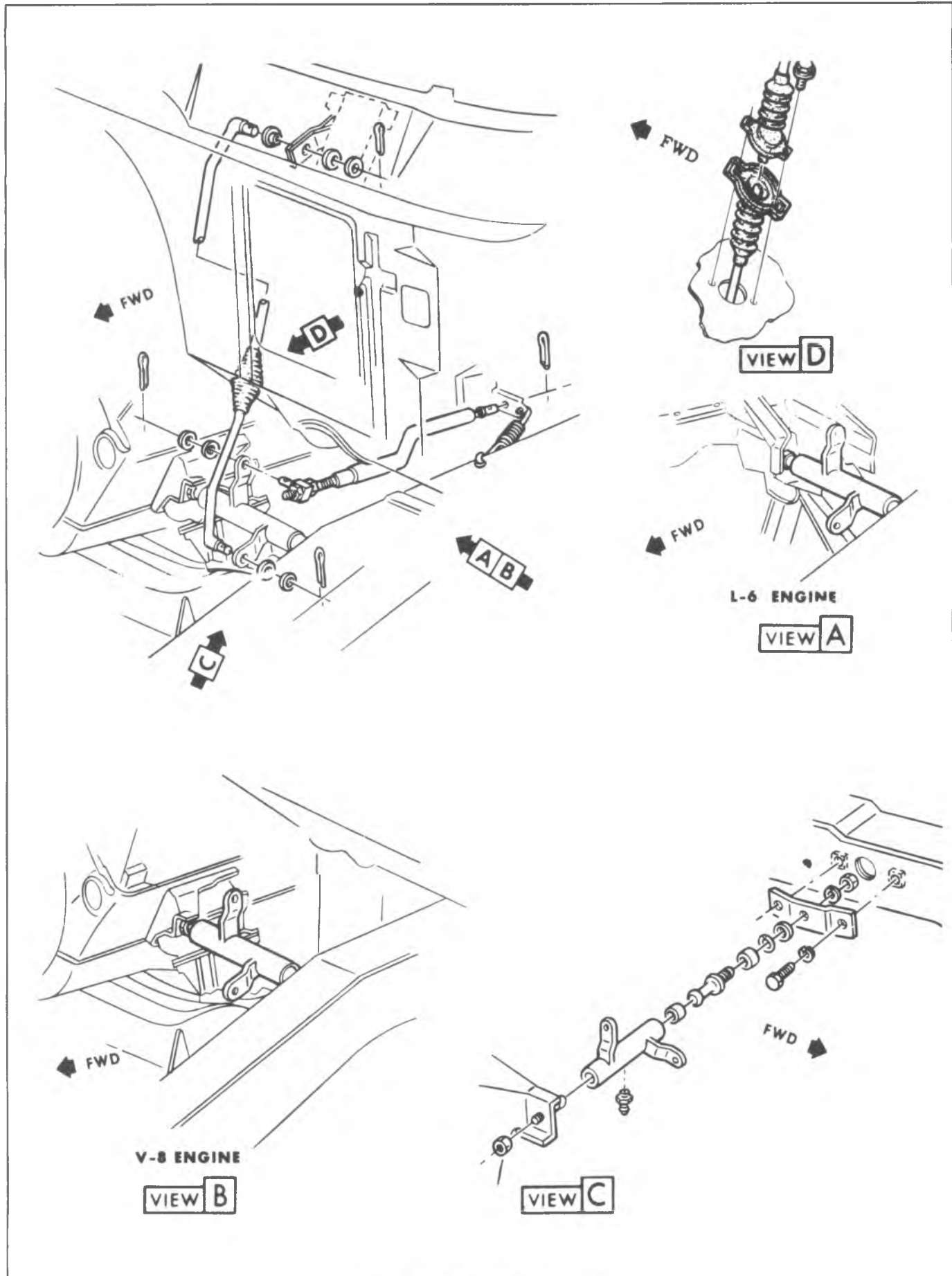

Fig. 7C-7--G-Truck Clutch Controls

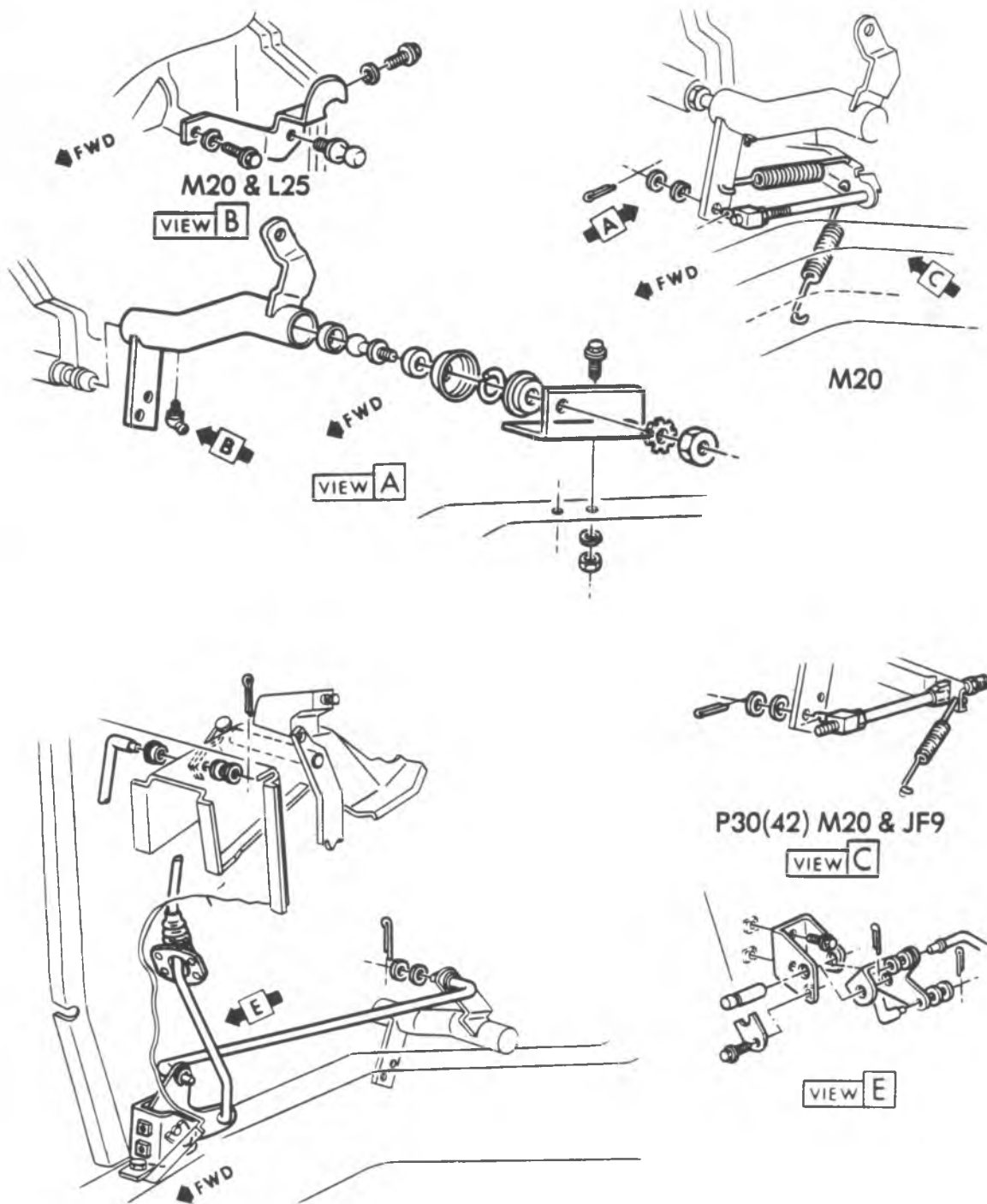

Fig. 7C-8--P-Truck Clutch Controls

## MAINTENANCE AND ADJUSTMENTS

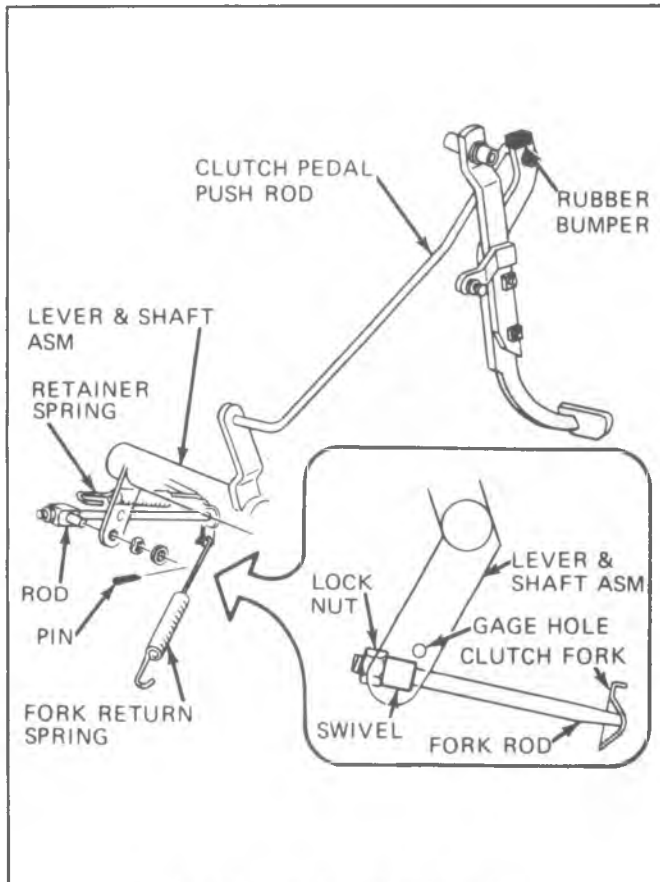

Fig. 7C-9--CK-Free Pedal Travel

### CLUTCH LINKAGE INSPECTION

There are several things which affect good clutch operations. Therefore, it is necessary, before performing any major clutch operations, to make preliminary inspections to determine whether trouble is actually in the clutch.

Check the clutch linkage to be sure the clutch releases fully as follows:

1. With engine running, hold the clutch pedal approximately 12.7mm (1/2 in.) from floor mat and move shift lever between first and reverse several times. If this can be done smoothly, the clutch is fully releasing. If shift is not smooth, clutch is not fully releasing and adjustment is necessary.
2. Check clutch pedal bushings for sticking or excessive wear.
3. Check fork for proper installation on ball stud. Lack of lubrication on fork can cause fork to be pulled off the ball.
4. Check for bent, cracked or damaged cross shaft levers or support bracket.
5. Loose or damaged engine mounts may allow the engine to shift its position causing a bind on clutch linkage at the cross shaft. Check to be sure there is some clearance between cross-shaft, both mount brackets, and ball studs.
6. Check clutch release bearing end clearance between spring fingers and front bearing retainer on the

transmission. If no clearance exists, fork may be improperly installed on ball stud or clutch disc may be worn out.

### CLUTCH FREE PEDAL TRAVEL ADJUSTMENT

Only one adjustment is necessary to compensate for all normal clutch wear. The clutch pedal should have free travel (measured at clutch pedal pad) before the release bearing engages the clutch diaphragm spring or levers. Lash is required to prevent clutch slippage which would occur if the bearing was held against the fingers or to prevent the bearing from running continually. A clutch that has been slipping prior to free play adjustment may still slip right after the new adjustment due to previous heat damage.

#### C, K and P Models (Except P30 W/JF9) (Fig. 7C-9)

1. Disconnect return spring at clutch fork.
2. Rotate clutch lever and shaft assembly until clutch pedal is firmly against rubber bumper on brake pedal bracket.
3. Push outer end of clutch fork rearward until release bearing lightly contacts pressure plate fingers or levers.
4. Loosen lock nut and adjust rod length so that swivel slips freely into gauge hole. Increase pushrod length until all lash is removed from system.
5. Remove swivel from gauge hole and insert into lower hole on lever. Install two washers and cotter pin. Tighten lock nut being careful not to change rod length.
6. Reinstall return spring and check pedal free travel. Pedal travel should be 35 to 41mm (1 3/8 to 1 5/8 in.) on "C-K" Models and 31 to 37mm (1 1/4 to 1 1/2 in.) on "P" models.

#### P-30 Models W/JF9 (Fig. 7C-10)

1. Disconnect clutch fork return spring.
2. Loosen nut 'G' at swivel.
3. Move the clutch fork rod against fork to eliminate all clearance between release bearing and clutch fingers.
4. Rotate shaft lever until clutch pedal contacts the bumper mounted on the brake pedal bracket.
5. Rotate the fork rod until a clearance of approximately 6.35 to 7.9mm (1/4 to 5/16 in.) is obtained between the shoulder on the fork rod and the adjustment nut.
6. Tighten nut 'G' against swivel and install clutch return spring.
7. Check free pedal clearance at pedal. Pedal clearance should be 35 to 41mm (1 3/8 to 1 5/8 in.). Readjust as required.

#### G-Models (Fig. 7C-11)

1. Disconnect clutch fork return spring at fork.
2. Loosen nut 'A' and back off from swivel approximately 12.7mm (1/2 in.).
3. Hold clutch fork push rod against fork to move release bearing against clutch fingers (push rod will slide through swivel at cross-shaft).

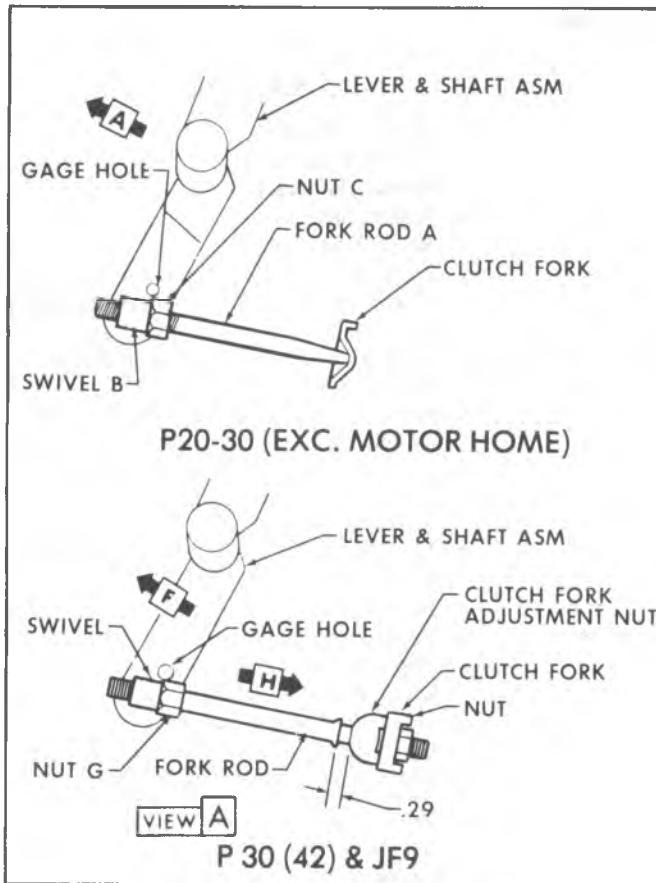

Fig. 7C-10-P-Truck Free Pedal Travel

4. Adjust nut 'B' to obtain approximately 6.35mm (1/4 in.) clearance between nut "B" and swivel.
5. Release push rod, connect return spring and tighten nut 'A' to lock swivel against nut 'B'.
6. Check free pedal clearance at pedal 31 to 37mm (1 1/4 to 1 1/2 in.) is proper clearance). Readjust if necessary.

### INSUFFICIENT CLUTCH RELEASE

Where complaints of first or reverse gear clash due to insufficient clutch release are encountered, the following

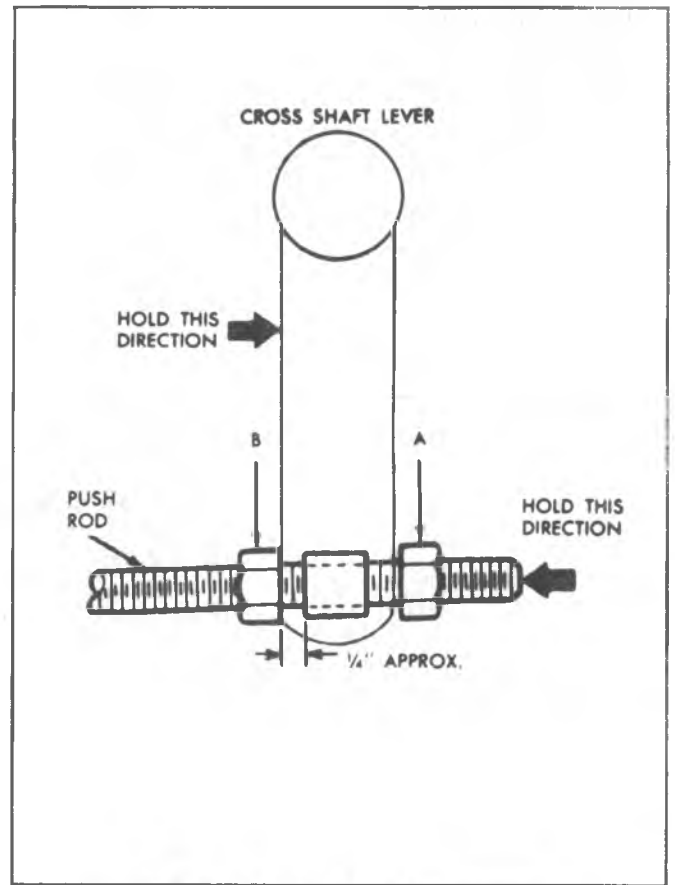

Fig. 7C-11-G-Truck Free Pedal Travel

may be helpful. Cut off the existing clutch pedal stop bumper to a height of 9.5mm (3/8 in.). Since shortening the bumper increases the lash and not the usable stroke, the lash must be reduced to specifications in order to gain the additional stroke benefit.



## DIAGNOSIS

| CONDITION   | PROBABLE CAUSE   | CORRECTION  |
|---|--|---|
| Fails to Release (Pedal pressed to floor-shift lever does not move freely in and out of reverse gear) | a. Improper linkage Adjustment<br>b. Improper pedal travel<br>c. Loose linkage<br>d. Faulty pilot bearing<br>e. Faulty driven disc<br>f. Fork off ball stud<br><br>g. Clutch disc hub binding on clutch gear spline<br>h. Clutch disc warped or bent     | a. Adjust Linkage<br>b. Trim bumper stop and adjust linkage<br>c. Replace as necessary<br>d. Replace bearing<br>e. Replace disc<br>f. Install properly and* lubricate fingers at release bearing with wheel bearing grease.<br>g. Repair or replace clutch gear and/or disc.<br>h. Replace disc (run-out should not exceed .020").<br><br>*Very lightly lubricate fingers |
| Slipping  | a. Improper Adjustment (no lash)<br>b. Oil Soaked driven disc<br><br>c. Worn facing or facing torn from disc.<br>d. Warped pressure plate or flywheel<br>e. Weak diaphragm spring<br><br>f. Driven plate not seated in<br><br>g. Driven plate overheated | a. Adjust linkage to spec.<br>b. Install new disc and correct leak at its source<br>c. Replace disc<br>d. Replace pressure plate or flywheel<br>e. Replace pressure plate (Be sure lash is checked before replacing plate.)<br>f. Make 30 to 40 normal starts<br>CAUTION: Do Not Overheat<br>g. Allow to cool – check lash  |
| Grabbing (Chattering)   | a. Oil on facing. Burned or glazed facings.<br>b. Worn splines on clutch gear.<br>c. Loose engine mountings.<br>d. Warped pressure plate or flywheel.<br>e. Burned or smeared resin on flywheel or pressure plate.                                       | a. Install new disc and correct leak.<br><br>b. Replace transmission clutch gear.<br>c. Tighten or replace mountings.<br>d. Replace pressure plate or flywheel.<br>e. Sand off if superficial, replace burned or heat checked parts.  |
| Rattling-Transmission Click   | a. Weak retracting springs.<br>b. Clutch fork loose on ball stud or in bearing groove.<br>c. Oil in driven plate damper.<br>d. Driven plate damper spring failure.   | a. Replace pressure plate.<br>b. Check ball stud and retaining.<br><br>c. Replace driven disc.<br>d. Replace driven disc.   |
| Release Bearing Noise with Clutch Fully Engaged   | a. Improper adjustment. No Lash.<br>b. Release bearing binding on transmission bearing retainer.<br>c. Insufficient tension between clutch fork spring and ball stud.<br>d. Fork improperly installed.<br>e. Weak linkage return spring.                 | a. Adjust linkage.<br>b. Clean, relubricate, check for burrs, nicks, etc.<br>c. Replace fork.<br><br>d. Install properly.<br>e. Replace spring.   |
| Noisy   | a. Worn release bearing.<br>b. Fork off ball stud (heavy clicking).<br><br>c. Pilot Bearing loose in crankshaft.   | a. Replace bearing.<br>b. Install properly and lubricate fork fingers at bearing.<br>c. See Section 6 for bearing fits.   |
| Pedal Stays on Floor When Disengaged  | a. Bind in linkage or release bearing.<br><br>b. Springs weak in pressure plate.<br>c. Springs being over traveled.  | a. Lubricate and free up linkage and release bearing.<br>b. Replace pressure plate.<br>c. Adjust linkage to get proper lash, be sure proper pedal stop (bumper) is installed.   |
| Hard Pedal Effort   | a. Bind in linkage.<br>b. Driven plate worn.   | a. Lubricate and free up linkage.<br>b. Replace driven plate.   |

## ON VEHICLE SERVICE

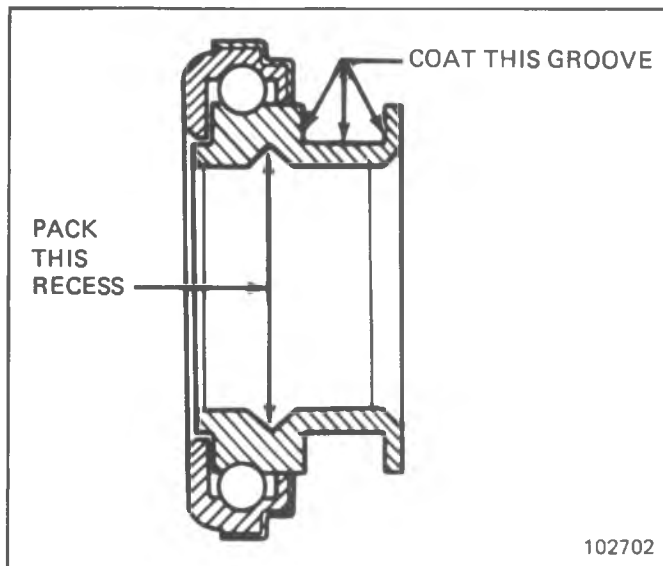

Fig. 7C-13--Lubrication Points on Clutch Release Bearing

### PRELIMINARY INSPECTION

There are many things which affect good clutch operation. Therefore, it is necessary, before performing any major clutch operations, to make a preliminary inspection to determine whether or not the trouble is actually in the clutch.

1. Check the clutch pedal and make sure that the pedal has proper free travel, as described in 'Maintenance and Adjustments'.
2. Check the clutch pedal bushing for wear and for sticking on the shaft or loose mountings.
3. Lubricate the pedal linkage.
4. Tighten all front and rear engine mounting bolts.

### CLUTCH DISC AND PRESSURE PLATE

#### (DIAPHRAGM TYPE)

##### Removal

1. Remove transmission as outlined in Section 7B.
2. Disconnect clutch fork push rod and pull back spring.
3. Remove clutch and flywheel housing.
4. Remove clutch fork by pressing it away from its ball mounting with a screwdriver, until the fork snaps loose from the ball or remove ball stud from rear of clutch housing. Remove release bearing from clutch fork.

The retainer may be removed from the fork by prying out with a small screwdriver.

5. Install Tool J-5824 or a used clutch drive gear to support the clutch assembly during removal.

Before removing clutch from flywheel, mark the flywheel, clutch cover and one pressure plate lug, so that these parts may be assembled in their same relative positions, as they were balanced as an assembly.

6. Loosen the clutch attaching bolts one turn at a time to prevent distortion of clutch cover until diaphragm spring is released.

7. Remove clutch pilot tool and remove clutch assembly from vehicle.

The flywheel should be inspected for cracks, heat checking, flatness and other defects.

##### Installation

1. Install the pressure plate in the cover assembly lining up the notch mark on pressure plate with notch mark on flange of cover.
2. Install pressure plate retracting springs, lockwashers and drive strap to pressure plate bolts. Tighten to 15 N·m (11 ft. lb.) torque. The clutch is now ready to be installed.
3. Hand crank the engine until 'X' mark on flywheel is at the bottom.
4. Install clutch disc, pressure plate and cover assembly and support them with Tool J-5824 or a used clutch drive gear.
5. Turn clutch assembly until 'X' mark or painted white letter on clutch cover flange lines up with 'X' mark on flywheel.
6. Install attaching bolts and tighten each one a turn at a time to prevent distorting the cover as the spring pressure is taken up.
7. Remove clutch pilot tool.
8. Pack clutch fork ball seat with a small amount of high melting point grease. On 'P' models with J76, install a new retainer in the groove of the clutch fork if the old retainer is worn or damaged.

Install retainer with high side up, away from bottom of the ball socket and with open end of retainer on the horizontal.

**NOTICE:** Be careful not to use too much lubricant. Excessive lubricant may get on clutch fingers and cause slippage or damage may result to the clutch.

9. Replace clutch fork ball if removed from the clutch housing and snap clutch fork onto the ball.
10. Pack lubricant in the recess on the inside of the release bearing collar and coat the clutch fork groove with a small amount of graphite grease, as shown in Fig. 7C-13.
11. Install release bearing assembly to the clutch fork. Install clutch and flywheel housing to engine.
12. Assemble transmission as outlined in Section 7B.
13. Align push rod to clutch fork and attach return spring to clutch fork.
14. Adjust clutch linkage as described in 'Maintenance and Adjustments.'

### CLUTCH DISC AND PRESSURE PLATE

#### (COIL SPRING TYPE)

##### Removal

1. Remove transmission as outlined in Section 7B.
2. Disconnect clutch fork push rod and pull back spring.
3. Remove clutch and flywheel housing.

## UNIT REPAIR

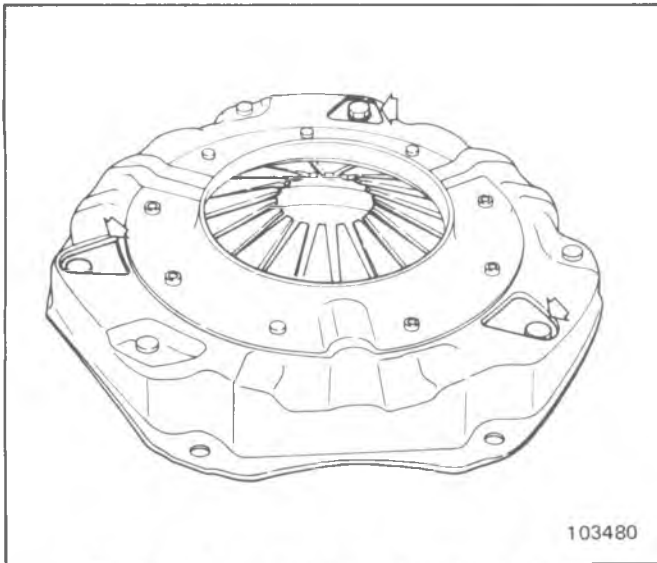

Fig. 7C-15--Retracting Spring Location (Typical)

### SINGLE PLATE DIAPHRAGM CLUTCH

#### Disassembly (Fig. 7C-15)

**NOTICE:** When disassembling, mark edge of pressure plate and cover. These marks must be aligned in assembly to maintain balance.

1. Remove three drive-strap to pressure plate bolts and retracting springs and remove pressure plate from clutch cover.
2. The clutch diaphragm spring and two pivot rings are riveted to the clutch cover. Spring, rings and cover should be inspected for excessive wear or damage and if there is a defect, it is necessary to replace the complete cover assembly.

#### Inspection

1. Check drive straps for looseness at the clutch cover and evidence of looseness at pressure plate bolt holes.
2. Wash all parts, except driven disk and release bearing, in cleaning solvent.

**NOTICE:** The release bearing is permanently packed with lubricant and should not be soaked in cleaning solvent as this will dissolve the lubricant.

3. Inspect pressure plate and flywheel for scores on the contact surfaces. Use a straight-edge and check for flatness of contact surfaces.
4. Check release bearing for roughness and free fit on the sleeve of the transmission clutch gear bearing retainer. Replace retainer if rough.
5. Inspect clutch disc for worn, loose or oil soaked facings, broken springs, loose rivets, etc. Replace if necessary.
6. Examine splines in hub and make sure they slide freely on splines of transmission clutch shaft. If splines are worn, the clutch disc or clutch gear should be replaced as necessary.
7. Inspect clutch fork ball socket and fingers for wear and ball retaining spring for damage. Spring should hold fork tightly to ball stud.

**NOTICE:** Ball spring on fork may be bent in toward fork if necessary.

8. Inspect ball stud for wear. Replace if scored.
9. Check run out of transmission pilot hole in clutch housing by removing a flywheel bolt and installing a dial indicator. The run out should be within .000-.015'.
10. Lubricate ball stud before reassembly.
11. Lubricate bearing I.D. and groove before reassembly.

#### Assembly

1. Install the pressure plate in the cover assembly, lining up the punch marks on the edge of the pressure plate with the punch marks on the edge of the cover.
2. Install pressure plate retracting springs and drivestraps to pressure plate bolts and lock washers and tighten to 15 N·m (11 ft. lbs.) torque. The clutch is now ready to be installed.

#### Pilot Bearing

##### Replacement (Except Diesel)

The clutch pilot bearing is an oil impregnated type bearing pressed into the crankshaft. This bearing requires attention when the clutch is removed from the vehicle, at which time it should be cleaned and inspected for excessive wear or damage and should be replaced if necessary.

To remove, install Tool J-1448 and remove bearing from crankshaft, as shown in (Fig. 7C-16). In replacing this bearing, use Tool J-1522. Place bearing on pilot of tool with radius in bore of bearing next to shoulder on tool and drive into crankshaft. Lubricate with several drops of machine oil.

The clutch pilot bearing used with the 6.2L Diesel Engine, is a Torrington bearing design. This bearing is a sealed unit and does not require lubrication.

To remove the bearing, use bearing puller J-23907. To install bearing, use installer J-34140. Place bearing on pilot of tool and drive into crankshaft until tool bottoms out.

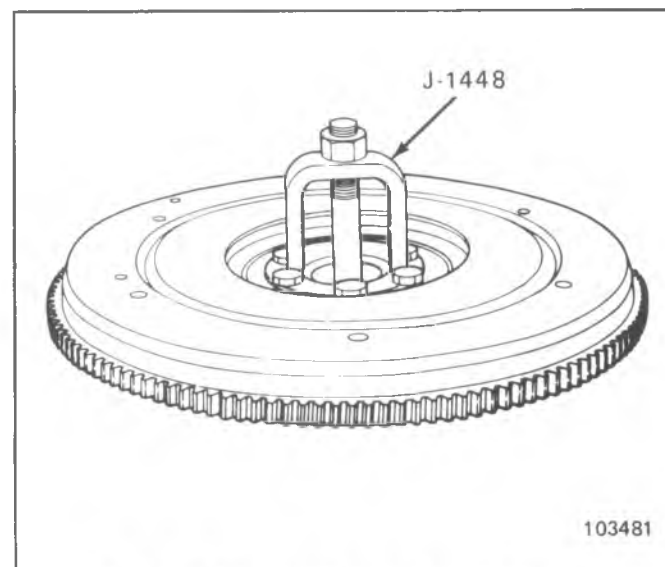

Fig. 7C-16--Clutch Pilot Bearing Removal (Typical)

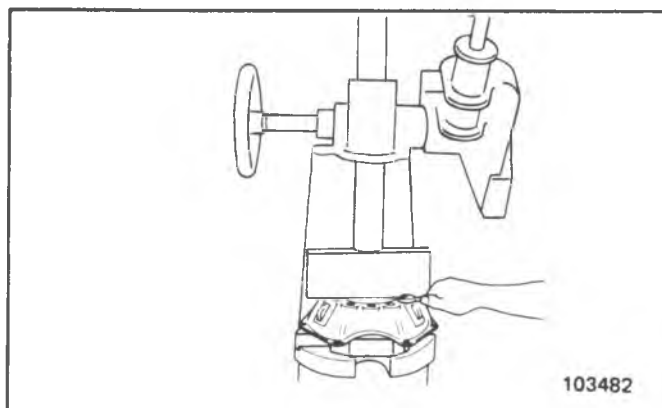

Fig. 7C-17--Compressing Clutch

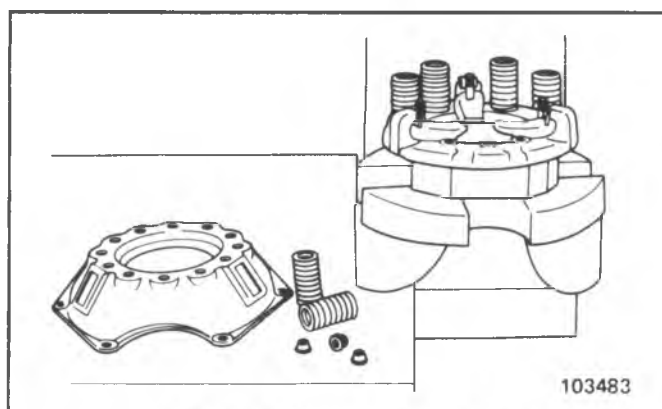

Fig. 7C-18--Disassembly of Clutch

## SINGLE PLATE COIL SPRING CLUTCH

### Disassembly

1. Place the cover assembly on the bed of an arbor or drill press with a block under the pressure plate so arranged that the cover is left free to move down.
2. Place a block or bar across the top of the cover with the spindle. Hold compressed while the adjusting nuts are removed, as shown in Fig. 7C-17. Then slowly release pressure to prevent springs flying out.
3. Lift off cover and all parts will be available for inspection. Note carefully the location of all parts including arrangement of springs. See Fig. 7C-18.
4. To remove levers grasp lever and eyebolt between thumb and fingers as shown in Figure 7C-19, so that

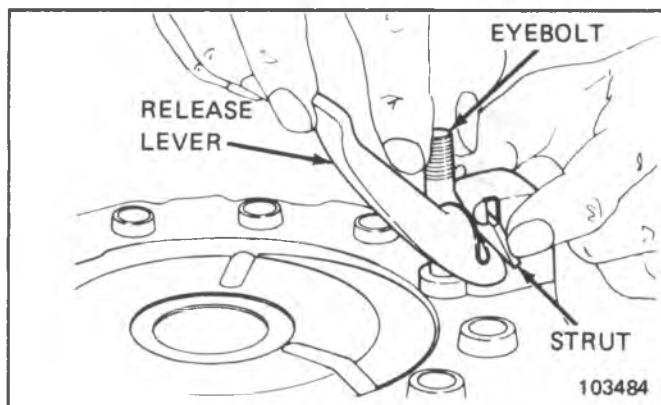

Fig. 7C-19--Grasping Lever and Strut

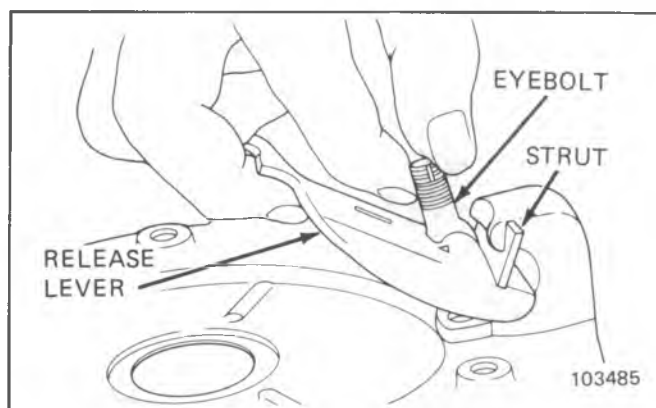

Fig. 7C-20--Removing or Installing Lever

inner end of lever and upper end of eyebolt are close together, keeping eyebolt pin seated in its socket in lever.

5. Lift strut over ridge on end of lever, as in Fig. 7C-20.
6. Lift lever and eyebolt off pressure plate.

**NOTICE:** It is important to replace all parts which show wear, to avoid damaging other components.

### Inspection

In addition to applicable items listed under Diaphragm Clutch Inspection, check the following items.

1. Check driving lugs for wear.
2. Check clutch cover for distortion or cracks.
3. Check release levers for wear or cracks.

### Assembly

1. Lay the pressure plate on the block in the press and coat the lugs with a thin film of approved lubricant such as lubriplate. See Fig. 7C-21.
2. Assemble lever, eyebolt and pin, holding eyebolt and lever as close together as possible and with the other hand grasp strut as shown in Fig. 7C-22.
3. Insert strut in the slots in the pressure plate lug, drop slightly and tilt the lower edge until it touches vertical milled surface of lug.
4. Insert lower end of eyebolt in hole in pressure plate. The short end of the lever will then be under the hook of the pressure plate and near the strut, as in Fig. 7C-20.

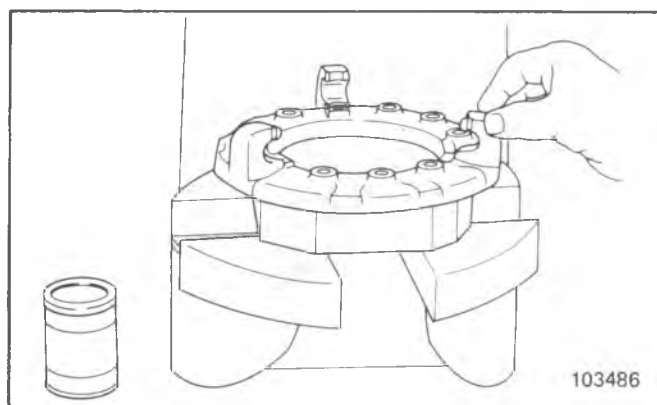

Fig. 7C-21--Greasing Lug

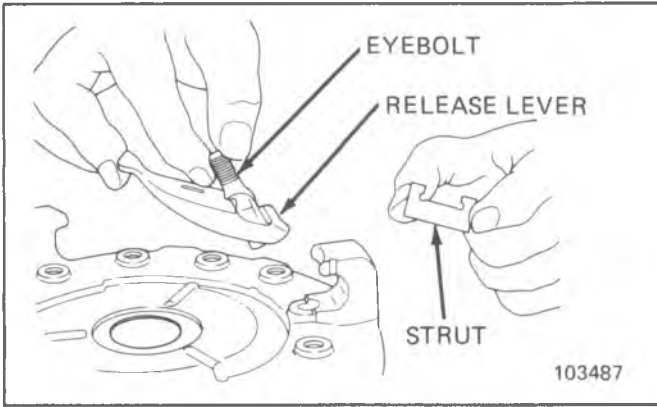

Fig. 7C-22--Installing Lever

5. Slide the strut upward in the slots of the lug, lifting it over the ridge on the short end of the lever and drop it into the groove in the lever, as shown in Fig. 7C-19.
6. Assemble the pressure springs, on the small bosses of the pressure plate in accordance with Fig. 7C-23 in order to retain original balance.

**NOTICE:** If there are spaces for more springs than specified for the particular assembly, or if two different colors of springs are used, Fig. 7C-23 shows the proper sequence. It is very important that each group be arranged in like sequence.

7. Assemble anti-rattle springs in cover. See Fig. 7C-24. The spring to the left is in operating position.
8. Lower the cover on top of the assembled parts, as in Fig. 7C-25. Be sure that the anti-rattle springs are in correct position and also that the punch marks made before dismantling are matched to insure retaining the original balance.
9. Place a bar across the cover and slowly compress, guiding the holes in the cover over the pressure plate lugs and all springs into their spring seats in the cover.
10. Assemble adjusting nuts on the eyebolts and screw them down until their tops are flush with the tops of the eyebolts. Slowly release pressure of spindle and remove cover assembly from press.

**Adjusting Levers**

While no wear adjustment is needed because of the coil spring design, it is imperative that the clutch release

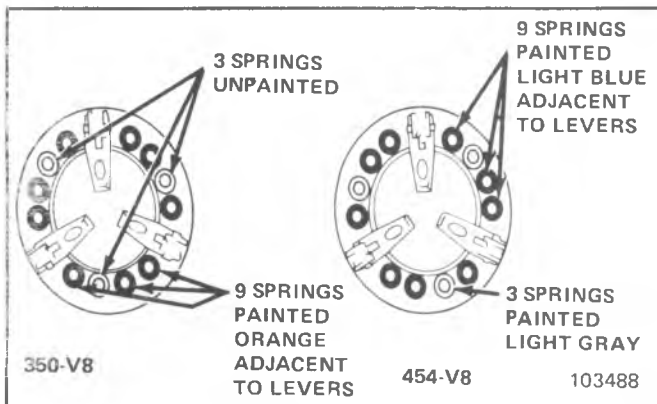

Fig. 7C-23--Spring Arrangement Diagram

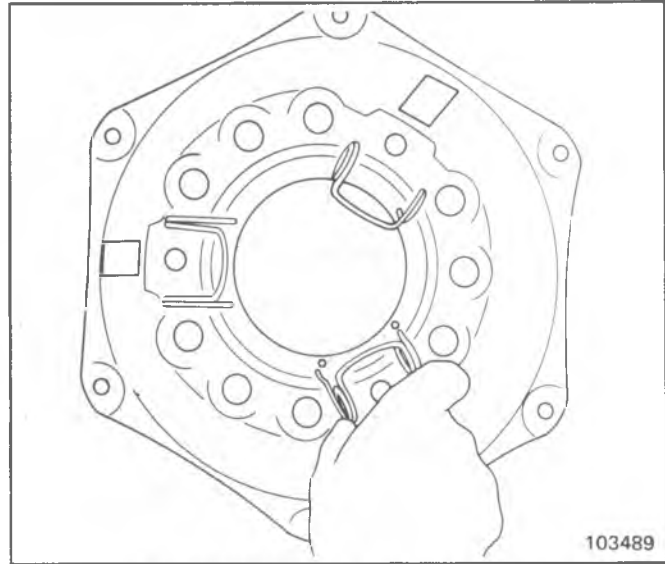

Fig. 7C-24--Installing Anti-Rattle Spring

levers are each set to exactly the same height at the time of rebuild to insure uniform clutch application. To obtain exactly the same adjustment at each release lever, use gauge plate J-1048 and release lever height gauge J-6456 as follows:

1. Place gauge plate J-1048 on the flywheel in position normally occupied by driven plate. See Fig. 7C-26. It is recommended that a spare flywheel be obtained so that this operation may be performed at the bench.
2. Bolt cover on flywheel with gauge plate center. (On assemblies with three levers, the three flat machined lands of the gauge plate must be located directly under the levers.)
3. Depress each lever several times with a hammer handle to settle all parts into working position, as shown in Fig. 7C-27.
4. Position height gauge J-6456-01 on the hub of the gauge plate and the bearing surface of one lever. Refer to Fig. 7C-28. Turn adjusting nut until lever is flush with the 12' step of J-6456-01. Adjust remaining levers in same manner.

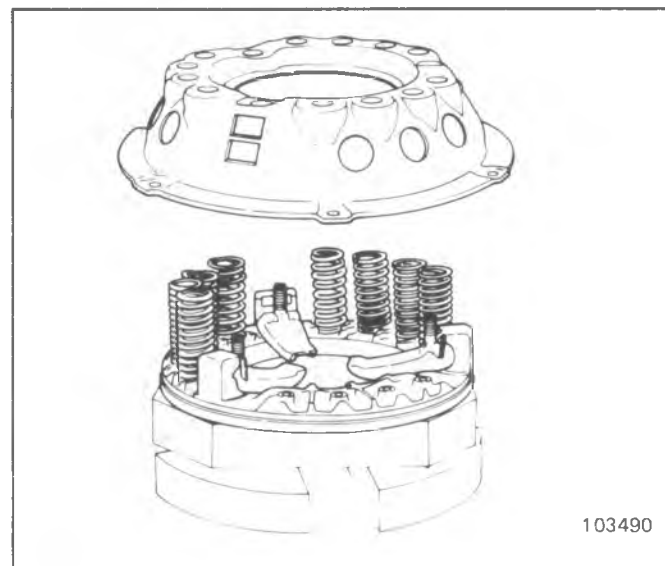

Fig. 7C-25--Assembling Cover and Pressure Plate

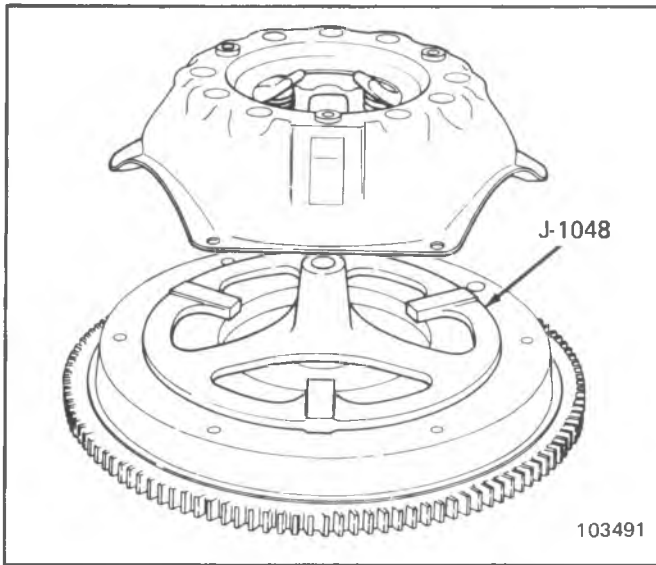

Fig. 7C-26--Gauge Plate Position

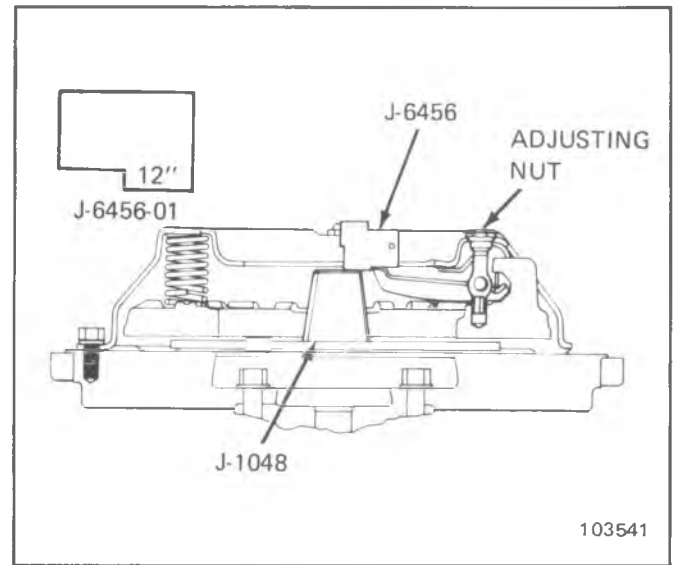

Fig. 7C-28--Coil Spring Clutch Adjustment

5. Stake adjusting nut, as shown in Fig. 7C-29, to eyebolt with a dull punch.
6. Loosen the cover to flywheel bolts a turn or two at a time and in rotation until spring pressure is relieved to allow clutch and gauge plate to be removed.

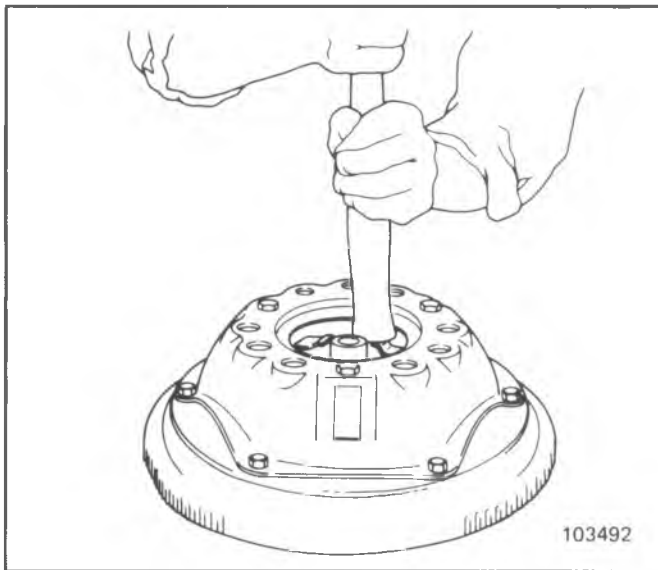

Fig. 7C-27--Depressing Lever

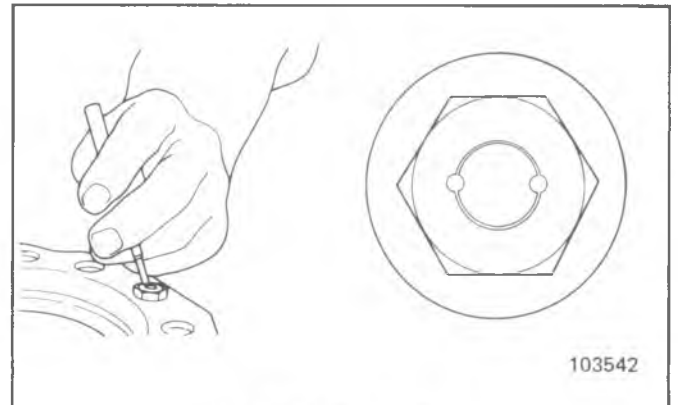
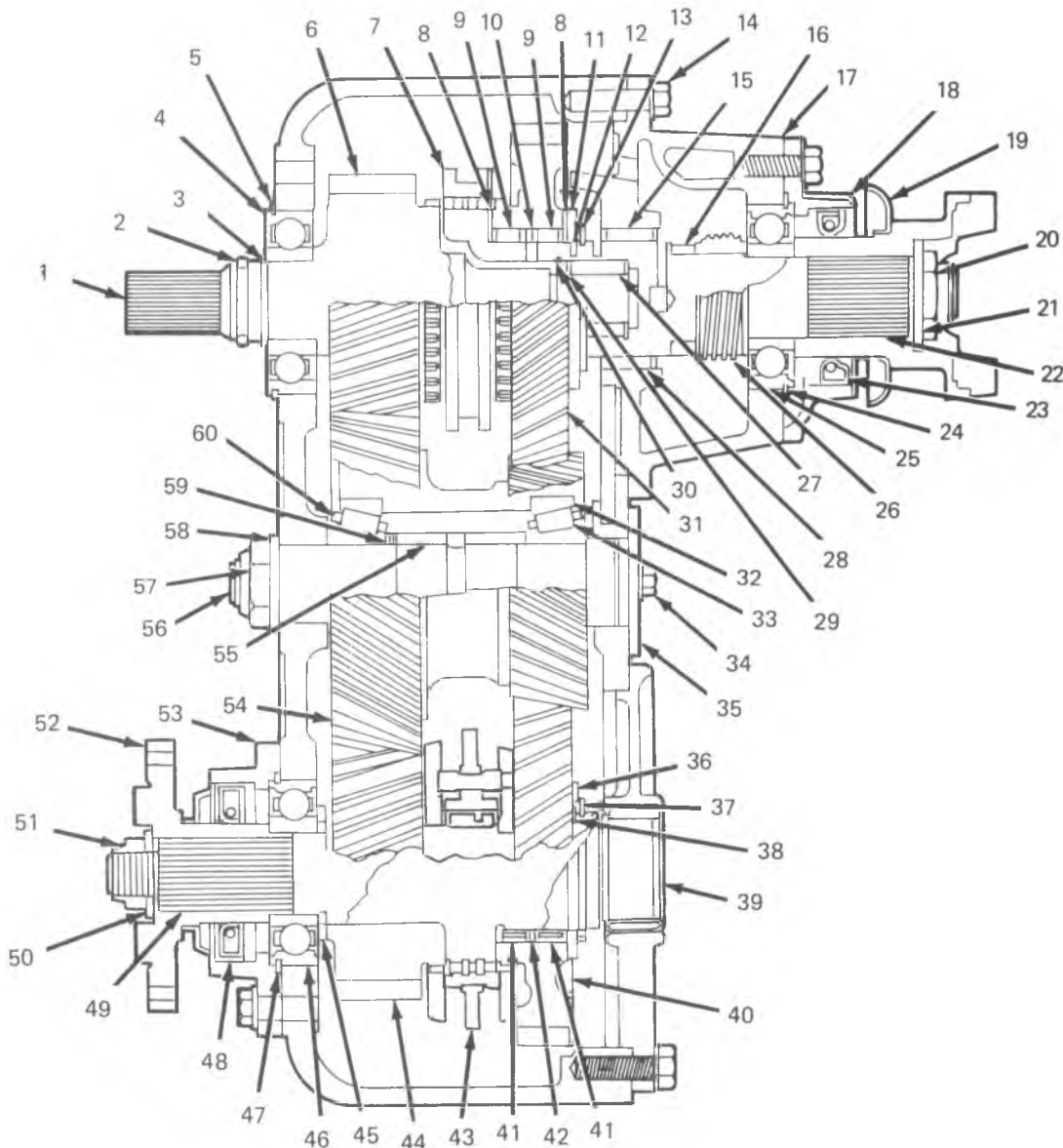

Fig. 7C-29--Staking Nut



- |                                |   |  |                         |
|--------------------------------|---|--|-------------------------|
| 1. Input Shaft                 | 18. Rear Bearing Retainer                   | 32. Idler Gear Shaft Bearing Cup                 | 42. Spacer              |
| 2. "O" Ring                    | 19. Rear Yoke Assembly                      | 33. Idler Shaft Bearing Cone                     | 43. Synchronizer        |
| 3. Snap Ring                   | 20. Locknut                                 | 34. Idler Shaft Cover Bolts and Lockwasher       | 44. Front Wheel Hi-Gear |
| 4. Bearing                     | 21. Washer                                  | 35. Idler Shaft Gear Cover and Gasket            | 45. Spacer              |
| 5. Snap Ring                   | 22. Rear Output Shaft Bearing Retainer Seal | 36. Thrust Washer                                | 46. Bearing             |
| 6. Input Shaft Gear            | 23. Bearing Retainer Seal                   | 37. Snap Ring                                    | 47. Snap Ring           |
| 7. Sliding Clutch              | 24. Snap Ring                               | 38. Thrust Washer Pin                            | 48. Seal                |
| 8. Tanged Bronze Thrust Washer | 25. Bearing                                 | 39. Rear Bearing Retainer and Output Shaft Cover | 49. Front Output Shaft  |
| 9. Roller Bearings             | 26. Speedometer Gear                        | 40. Front Wheel Drive Low Gear                   | 50. Washer              |
| 10. Spacer                     | 27. Pilot Bearings                          | 41. Roller Bearings                              | 51. Locknut             |
| 11. Thrust Washer              | 28. Rear Output Shaft Front Bearing         |  | 52. Output Yoke         |
| 12. Thrust Washer Pin          | 29. Washer                                  |  | 53. Bearing Retainer    |
| 13. Snap Ring                  | 30. Bearing Retainer                        |  | 54. Idler Gear          |
| 14. Bolt and Lockwasher        | 31. Rear Wheel Drive Low Gear               |  | 55. Idler Gear Spacer   |
| 15. Needle Bearings            |   |  | 56. Idler Shaft         |
| 16. Spacer                     |   |  | 57. Locknut             |
| 17. Rear Output Shaft Housing  |   |  | 58. Washer              |
|                                |   |  | 59. Bearing Cone        |
|                                |   |  | 60. Bearing Cup         |

102818

Fig. 7E-36--Model 205 Transfer Case (Cross Section)

## MAINTENANCE AND ADJUSTMENTS

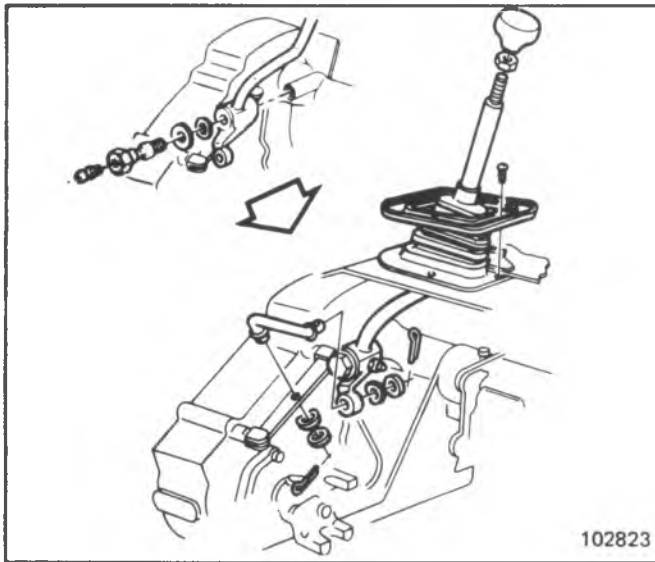

Fig. 7E-37--Model 205 Linkage

### LUBRICATION INFORMATION

Refer to Section 0B of this manual for detailed information on recommended intervals and types of lubricant.

### LINKAGE ADJUSTMENT AND INSPECTION

The control linkage for the transfer part-time case is shown in Fig. 7E-37. Periodically inspect the linkage system for freedom of operation, proper engagement, loose attaching bolts foreign material, etc. Adjust, clean and tighten as necessary.

## DIAGNOSIS

| COMPLAINT                              | POSSIBLE CAUSES   | REMEDIES  |
|--|---|---|
| Excessive Noise                        | <ol style="list-style-type: none"> <li>1. Lubricant level-low</li> <li>2. Worn or damaged bearings</li> <li>3. Misalignment of drive shafts or universal joints</li> <li>4. Yoke bolts loose</li> <li>5. Loose adapter bolts</li> </ol> | <ol style="list-style-type: none"> <li>1. Fill as required</li> <li>2. Replace</li> <li>3. Align</li> <li>4. Torque to specs.</li> <li>5. Torque to specs.</li> </ol> |
| Shifter Lever Difficult to Move        | <ol style="list-style-type: none"> <li>1. Binding inside transfer case</li> </ol>   | <ol style="list-style-type: none"> <li>1. Repair as required</li> </ol>   |
| Shifter Lever Disengages from Position | <ol style="list-style-type: none"> <li>1. Gears worn or damaged</li> <li>2. Shift rod bent</li> <li>3. Missing detent ball or spring</li> </ol>   | <ol style="list-style-type: none"> <li>1. Replace</li> <li>2. Replace</li> <li>3. Replace</li> </ol>  |
| Lubricant Leaking                      | <ol style="list-style-type: none"> <li>1. Excessive lubricant in case</li> <li>2. Leaking seals or gaskets</li> <li>3. Loose bolts</li> <li>4. Scored yoke in seal contact area</li> </ol>  | <ol style="list-style-type: none"> <li>1. Adjust level</li> <li>2. Replace</li> <li>3. Tighten</li> <li>4. Refinish or replace</li> </ol>                             |

Fig. 7E-38--Transfer Case Diagnosis

## ON VEHICLE SERVICE

### TRANSFER CASE

#### Removal (Fig. 7E-39)

1. Raise and support vehicle on hoist. Drain transfer case.
2. Disconnect speedometer cable.
3. Remove skid plate and crossmember supports as necessary.
4. Disconnect rear prop shaft from transfer case and tie up away from work area.
5. Disconnect front prop shaft from transfer case and tie up shaft away from work area.

6. Disconnect shift lever rod from shift rail link.
7. Support transfer case and remove bolts attaching transfer case to transmission adapter.
8. Move transfer case to rear until input shaft clears adapter and lower assembly from vehicle.

#### Installation

1. Support transfer case in suitable stand and position case to transmission adapter. Install bolts attaching case to adapter and torque to 61 N·m (45 ft. lb.).
2. Remove stand.
3. Install connecting rod to shift rail link or connect shift



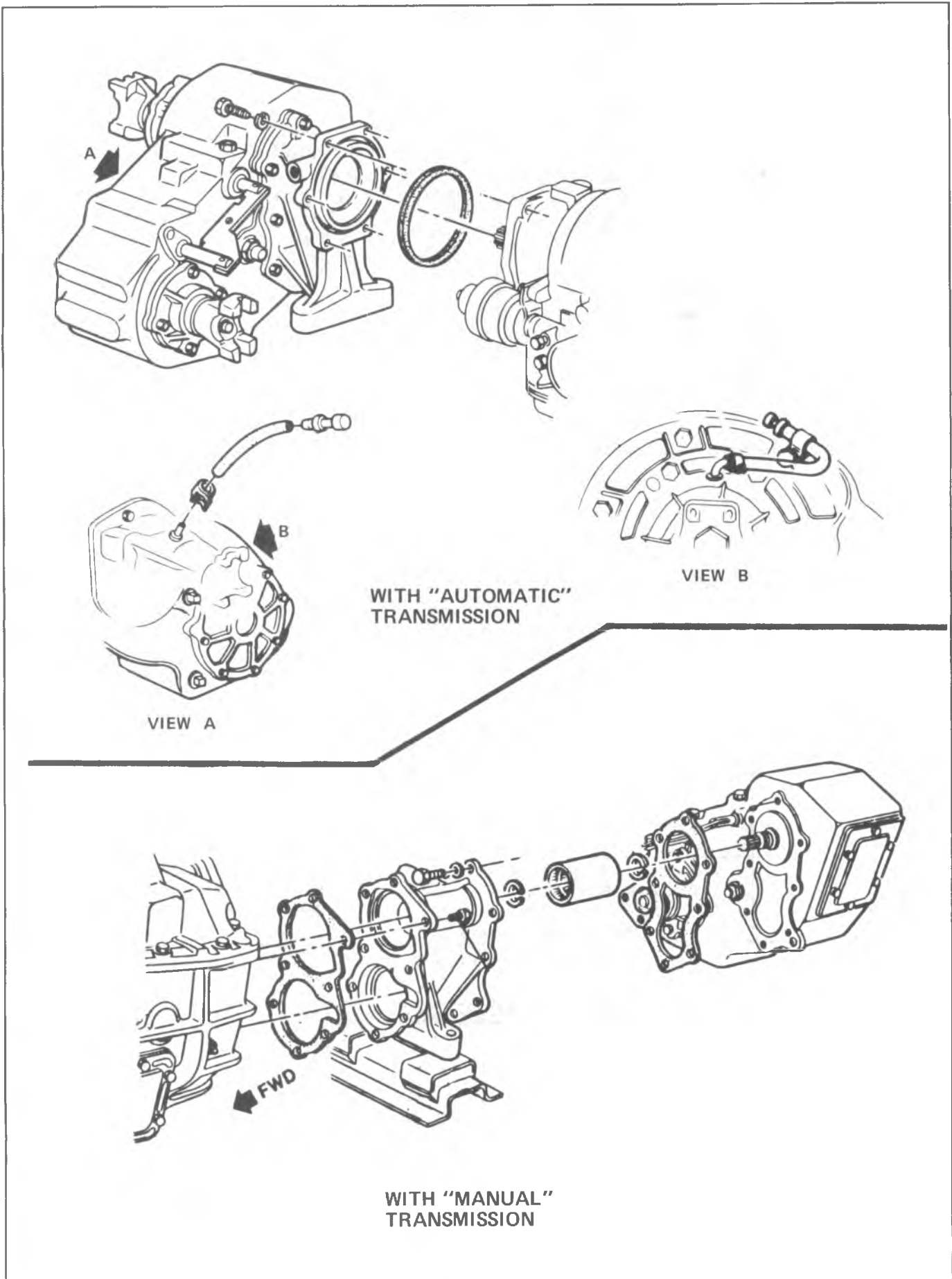

Fig. 7E-39--Transfer Case Attachment-Typical

levers to transfer case, as applicable.

4. Connect front prop shaft to transfer case front output flange or yoke.
5. Connect rear prop shaft to transfer case rear output yoke.
6. Install crossmember support and skid plate, if removed.
7. Connect speedometer cable.
8. Fill transfer case to proper level with lubricant specified in Section 0B.
9. Lower and remove vehicle from hoist.  
Check and tighten all bolts to specified torques.  
Before connecting prop shafts to companion flanges, be sure locknuts are torqued to specifications.

### SKID PLATE

### STRUT ROD

### ADAPTER ASSEMBLIES

Attachment of the above items is shown in Fig. 7E-39, 40 and 41. Refer to these figures when removing or replacing these components.

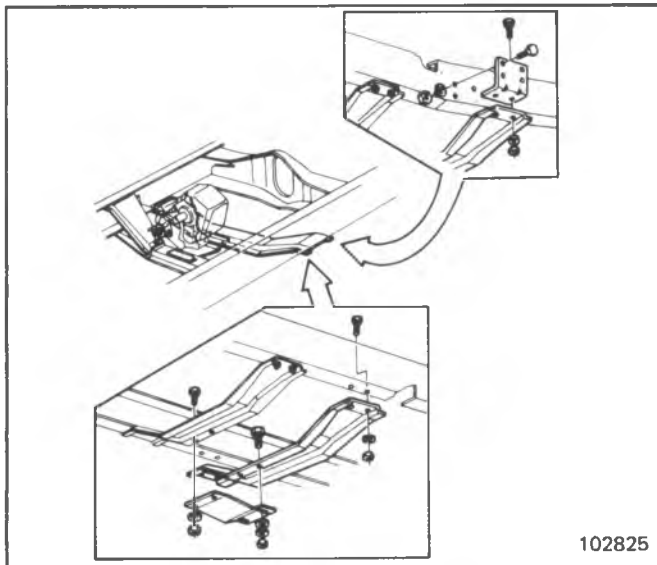

Fig. 7E-40--Skid Plates

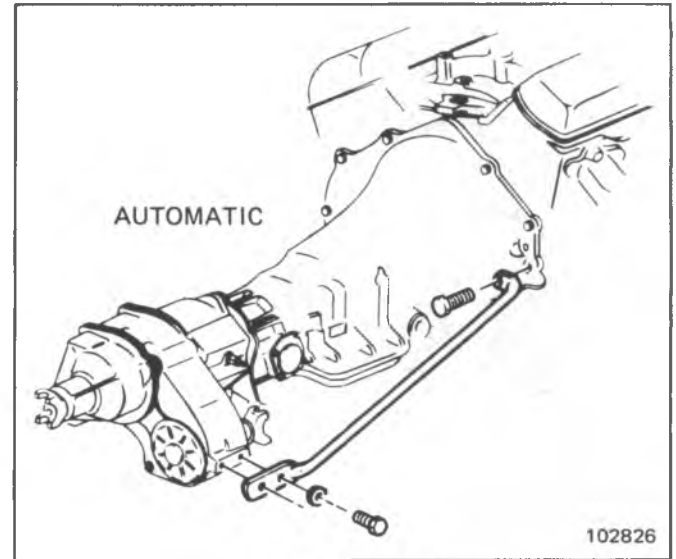

Fig. 7E-41--Strut Rods

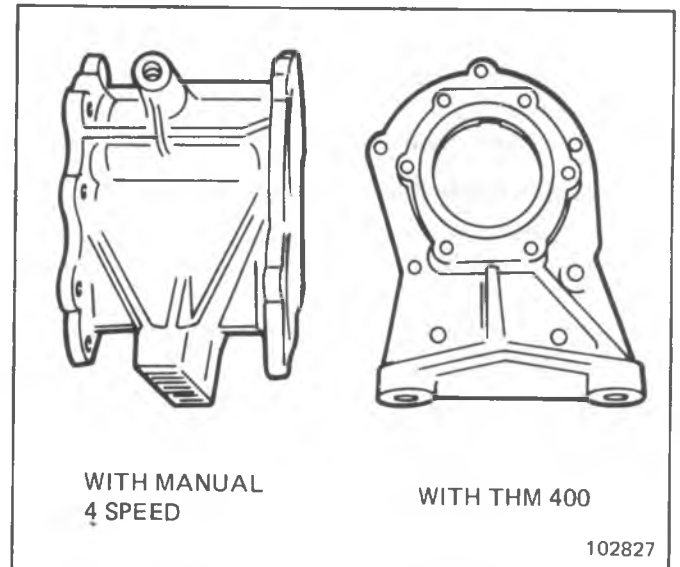

Fig. 7E-42--Adapter Assemblies

## UNIT REPAIR

### DISASSEMBLY OF TRANSFER CASE (FIG. 7E-46)

#### Rear Output Shaft and Yoke Assembly (Fig. 7E-43)

1. Loosen rear output shaft yoke nut.
2. Remove rear output shaft housing bolts and remove housing and retainer assembly from case.
3. Remove retaining nut and yoke from shaft, then remove shaft assembly from housing.
4. Remove snap ring using Tool J-23432 and discard.
5. Remove thrust washer and washer pin.
6. Remove tanged bronze washer. Remove gear needle bearings (32 per row), spacer and second row of needle bearings.

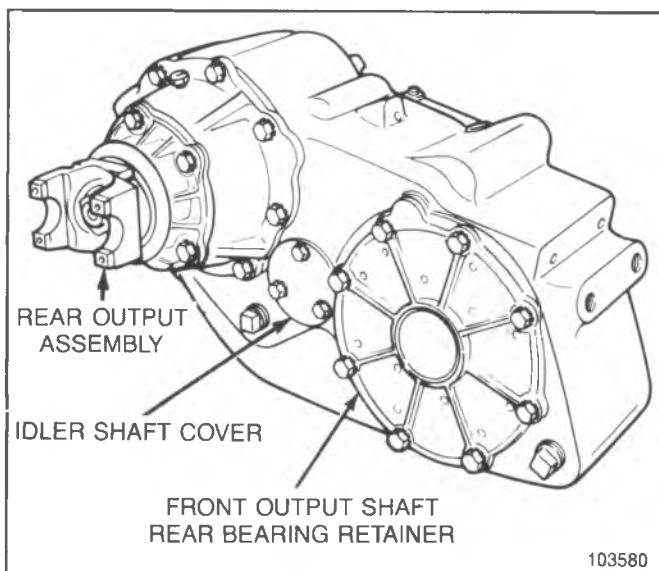

Fig. 7E-43--Rear View of Transfer Case

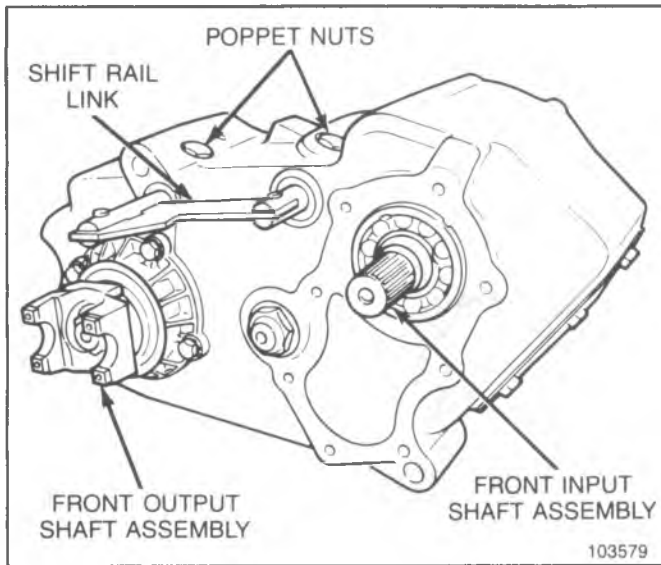

Fig. 7E-44--Front View of Transfer Case

7. Remove tanged bronze thrust washer from shaft.
8. Remove pilot rollers (15), retainer ring and washer.
9. Remove oil seal retainer, ball bearing, speedometer gear and spacer. Discard all gaskets. Press out bearing as required.
10. Remove oil seal from the retainer.

#### Front Output Shaft Assembly (Fig. 7E-44)

1. Remove lock nut, washer and yoke.
2. Remove front bearing retainer attaching bolts and retainer.
3. Remove front output shaft rear bearing retainer attaching bolts.
4. Tap on output shaft with a soft hammer (Fig. 7E-45) and remove shaft, gear assembly, and rear bearing retainer from case.  
Remove the synchronizer from output high gear, washer, and bearing which will have remained in the case.
5. Using large snap ring picks, such as J-23432-1, remove the gear retaining ring from the shaft (Fig. 7E-47) and discard.
6. Remove thrust washer and pin from shaft.
7. Remove gear, needle bearings (32 per row) and spacer.
8. If necessary to replace front output shaft rear bearing, support cover and press bearing from cover. Position new bearing to outside face of cover and using a piece of pipe or wood to cover outside diameter of bearing, press bearing into cover until flush with opening.

#### Shift Rail and Fork Assemblies

1. Remove the two poppet nuts on top of case, two poppet springs, and using a magnet, remove the poppet bailes.
2. Drive cup plugs into case using a 6.35mm (1/4 in.) punch.
3. Position both shift rails in neutral and using a long, narrow punch, drive shift fork pins through shift rails into the case (Fig. 7E-48).

4. Remove clevis pins and shift rail link.
5. Remove shift rails (Fig. 7E-49), upper (range) rail first, then lower (4-wheel) rail.
6. Remove shift forks and sliding clutch from case.
7. Remove the front output high gear, washer, and bearing from the case. Remove the shift rail cup plugs and pins from the case.
8. Remove snap ring in front of bearing. Using a soft hammer, tap shaft out rear of case. Tap bearing out front of case.
9. Tip case on PTO and remove two interlock pins from inside of case.

#### Idler Gear

1. Remove idler gear shaft nut.
2. Remove idler shaft rear cover.
3. Remove idler gear shaft using a soft hammer and tool J-23429 (Fig. 7E-50).
4. Roll idler gear to front output shaft hole and remove from case.
5. Remove bearing cups (2) as required from idler gear.

#### CLEANING AND INSPECTION

**Bearings**--Place all bearings and rollers in cleaning solution and allow to remain long enough to loosen all accumulated lubricant. Bearings should be sloshed up and down and turned slowly below surface of solution to remove as much lubricant as possible. Remove bearings and blow out with compressed air, being careful to direct air across bearing so that bearings do not spin.

**Shafts and Gears**--Clean all shafts in cleaning solution to remove all accumulations. Dry with compressed air.

**Case, Cover and Bearing Cups**--Transfer case, cover, and bearing cups must be thoroughly cleaned in solution to remove all accumulation of lubricant and dirt. Remove all trace of gaskets from surface where used.

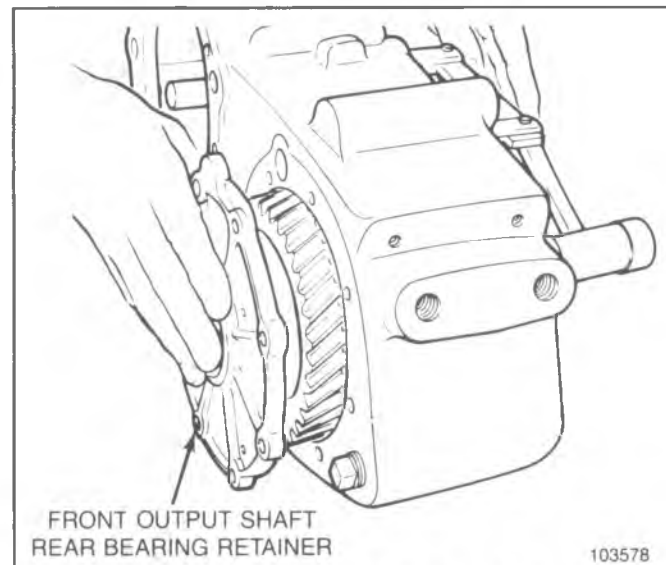
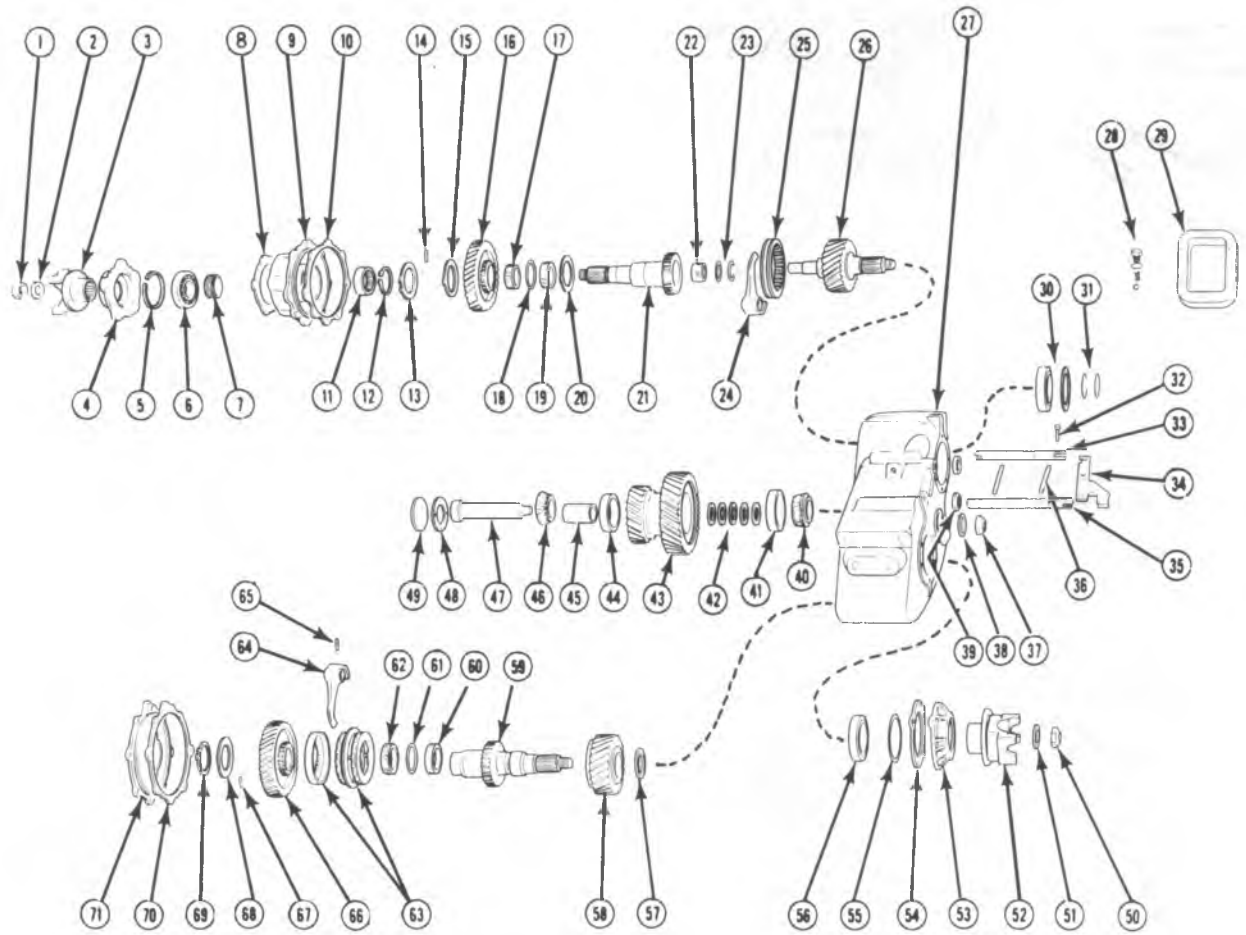

Fig. 7E-45--Removing Front Output Shaft Rear Bearing Retainer



- |                                       |  |                                |
|---------------------------------------|--|--------------------------------|
| 1. Rear Output Shaft Locknut          | 26. Input Shaft                                      | 49. Rear Cover                 |
| 2. Washer                             | 27. Transfer Case                                    | 50. Front Output Shaft Locknut |
| 3. Yoke                               | 28. Poppet Spring & Ball, Light Switch Spring & Ball | 51. Washer                     |
| 4. Bearing Retainer and Seal Assembly | 29. P T O Gasket and Cover                           | 52. Yoke                       |
| 5. Snap Ring                          | 30. Input Shaft Bearing and Snap Ring                | 53. Bearing Retainer and Seat  |
| 6. Bearing                            | 31. Snap Ring and Rubber "O" Ring                    | 54. Gasket                     |
| 7. Speedometer Gear                   | 32. Shift Link Clevis Pin                            | 55. Snap Ring                  |
| 8. Gasket                             | 33. Range Shift Rail                                 | 56. Front Bearing              |
| 9. Housing                            | 34. Shift Rail Connector Link                        | 57. Thrust Washer              |
| 10. Gasket                            | 35. Front Wheel Drive Shift Rail                     | 58. Front Wheel High Gear      |
| 11. Bearing                           | 36. Interlock Pins                                   | 59. Front Output Shaft         |
| 12. Snap Ring                         | 37. Rear Idler Lock Nut                              | 60. Needle Bearings            |
| 13. Thrust Washer                     | 38. Washer   | 61. Spacer                     |
| 14. Thrust Washer Lock Pin            | 39. Shift Rail Seals                                 | 62. Needle Bearing             |
| 15. Thrust Washer (Tanged)            | 40. Idler Shaft Bearing                              | 63. Synchronizer               |
| 16. Low Speed Gear                    | 41. Bearing Cup                                      | 64. Shift Fork                 |
| 17. Needle Bearings                   | 42. Shims  | 65. Roll Pin                   |
| 18. Spacer                            | 43. Idler Gear                                       | 66. Front Output Low Gear      |
| 19. Needle Bearings                   | 44. Bearing Cup                                      | 67. Thrust Washer Lock Pin     |
| 20. Tanged Washer                     | 45. Spacer   | 68. Thrust Washer              |
| 21. Rear Output Shaft                 | 46. Idler Shaft Bearing                              | 69. Snap Ring                  |
| 22. Needle Bearings                   | 47. Idler Shaft                                      | 70. Rear Cover Gasket          |
| 23. Washer and Retainer               | 48. Cover Gasket                                     | 71. Rear Cover and Bearing     |
| 24. Shift Fork                        |  |                                |
| 25. Sliding Clutch                    |  |                                |

Fig. 7E-46--Model 205 Transfer Case-Exploded View

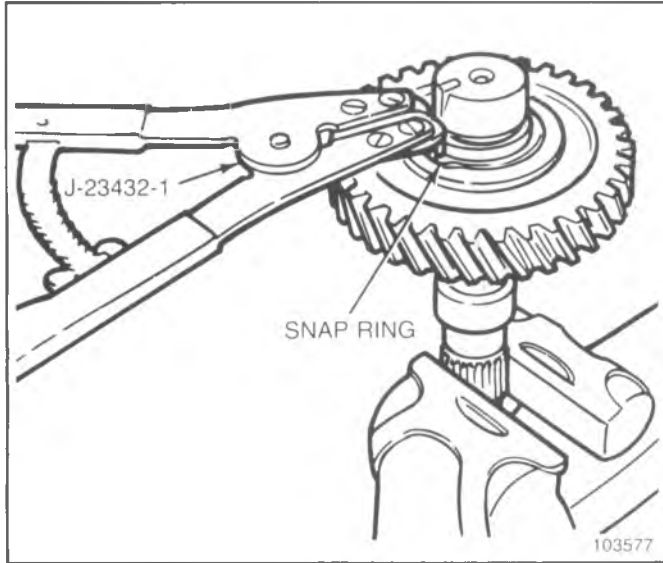

Fig. 7E-47--Removing Gear Retaining Ring

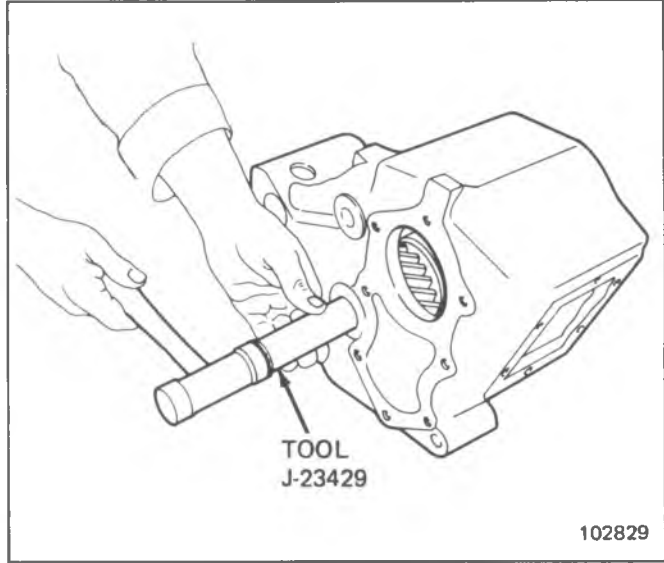

Fig. 7E-50--Removing Idler Gear Shaft

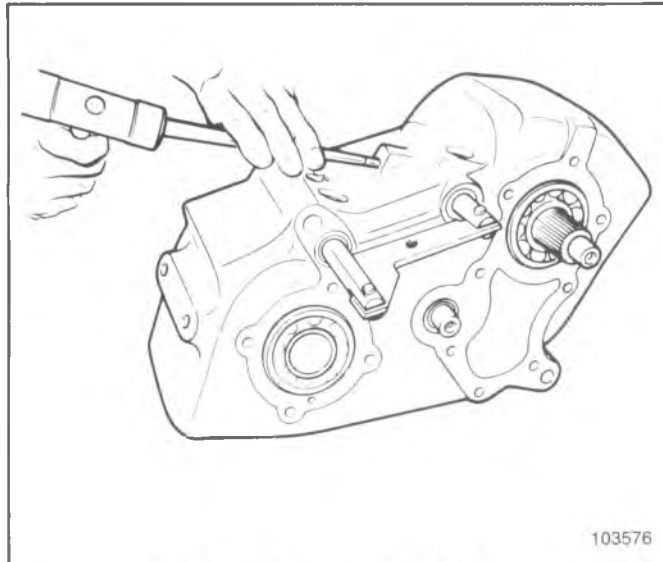

Fig. 7E-48--Removing Shift Fork Pins

**Synchronizer**--The synchronizer can be installed in any direction as the sides are identical. Synchronizer wear could occur on engagement side, if wear is present, use opposite side of synchronizer and reassemble.

**Inspection**--Carefully inspect all bearings and rollers for evidence of chipping, cracks, or worn spots that would render bearing unfit for further service. Bearings are nonadjustable and if worn or damaged, must be replaced with new parts.

Inspect shaft splines and gears. If any indication of failure, such as chipped teeth or excessive wear, is indicated, those parts should be replaced with new parts.

**ASSEMBLY OF TRANSFER CASE (FIG. 7E-46)**

**Idler Gear**

1. Press the two bearing cups in the idler gear (if previously removed) using Tool J-9276-2 and Handle J-8092 (Fig. 7E-51).
2. Assemble the two bearing cones, spacer, shims and idler gear on dummy shaft J-23429 with bore up. Check

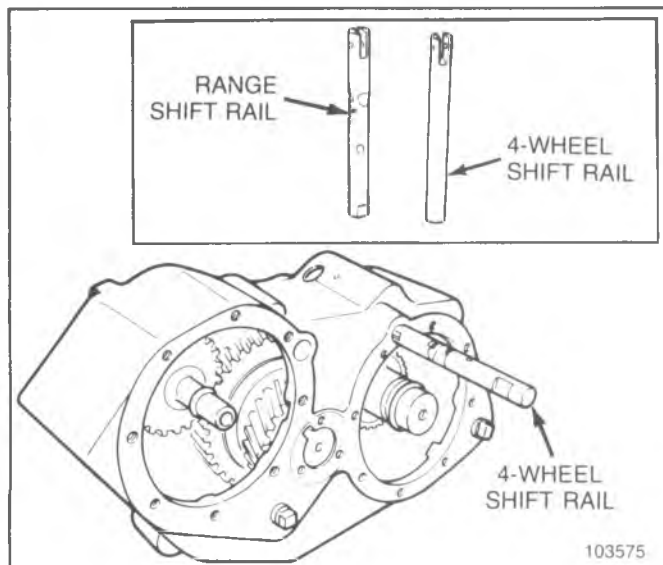

Fig. 7E-49--Shift Rail Removal

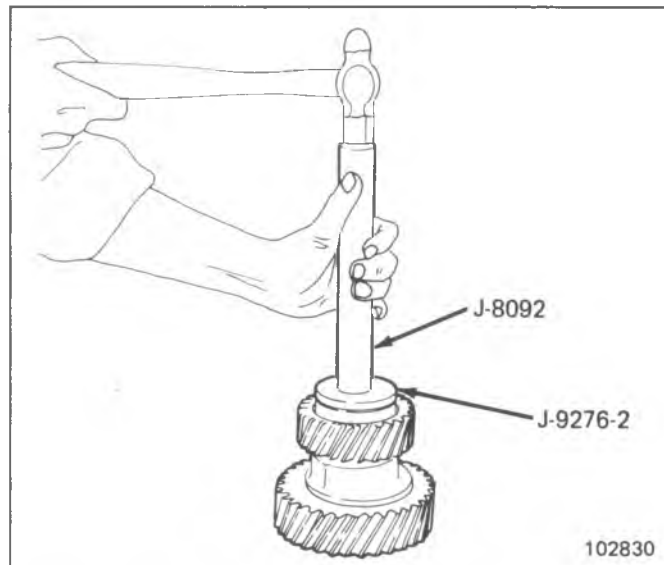

Fig. 7E-51--Installing New Bearing Cups

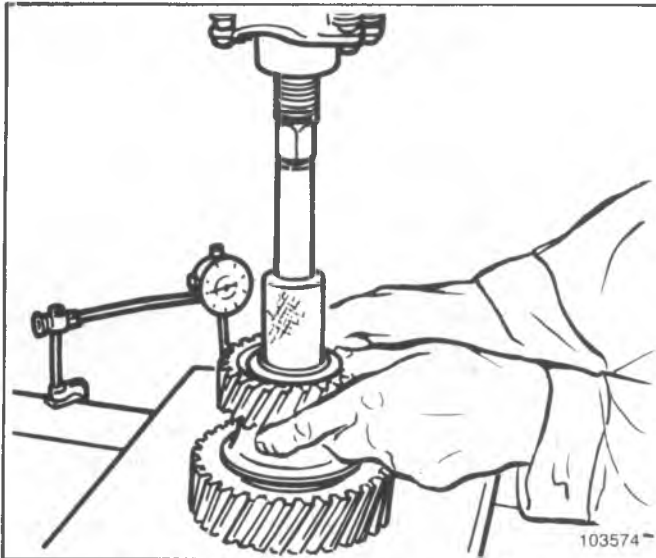

Fig. 7E-52--Checking Idler Gear End Play

end play (Fig. 7E-52). Limits are 0.001 to 0.002 inch.

3. Install idler gear assembly with dummy shaft into case through front output bore, large end first (Fig. 7E-53).
4. Install idler shaft from large bore side and drive through using a soft hammer (Fig. 7E-54).
5. Install washer and new locknut. Check for end play and free rotation. Torque nut to 202 N·m (150 ft. lb.).
6. Install idler shaft cover and gasket. Torque bolts to 27 N·m (20 ft. lb.).

Flat on cover must be located adjacent to front output shaft rear cover (Fig. 7E-55).

### Shift Rail and Fork Assemblies

1. Press the two rail seals into the case. Seals should be installed with metal lip outward.
2. Install interlock pins through large bore or PTO opening.

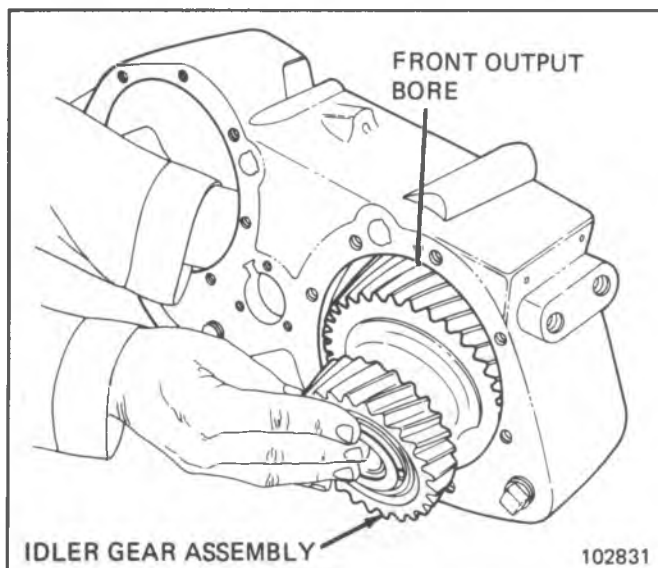

Fig. 7E-53--Installing Idler Gear

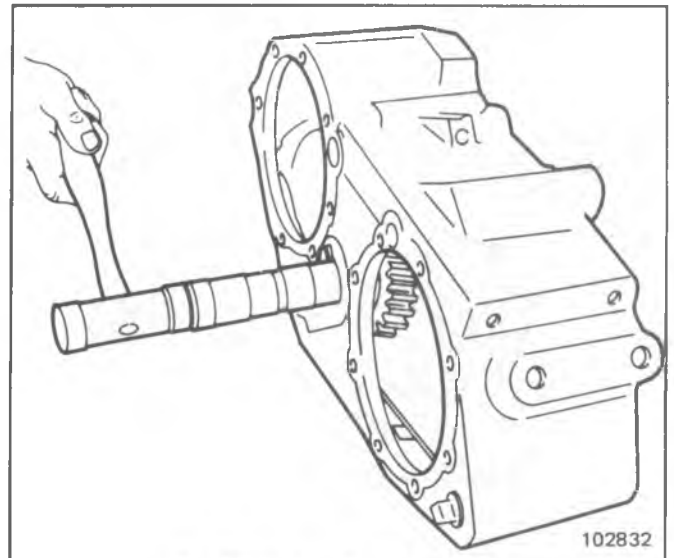

Fig. 7E-54--Installing Idler Shaft

3. Start front output drive shift rail into case from back, slotted end first, with poppet notches up.
4. Install shift fork (long end inward) into rail, push rail through to neutral position.
5. Install input shaft bearing and shaft into case.
6. Start range rail into case from front, with poppet notches up.
7. Install sliding clutch onto fork, place over input shaft in case. Position to receive range rail and push rail through to neutral position.
8. Install new lock pins through holes at top of case and drive them into the forks (Fig. 7E-56). Tip case on PTO opening when installing range rail lock pin.

### Front Output Shaft and Gear Assembly

1. Install two rows of needle bearings (32 each) separated by a spacer in the front low output gear and retain with a sufficient amount of grease.
2. Place front output shaft in soft jawed vise, spline end down. Install front low gear over shaft with clutch

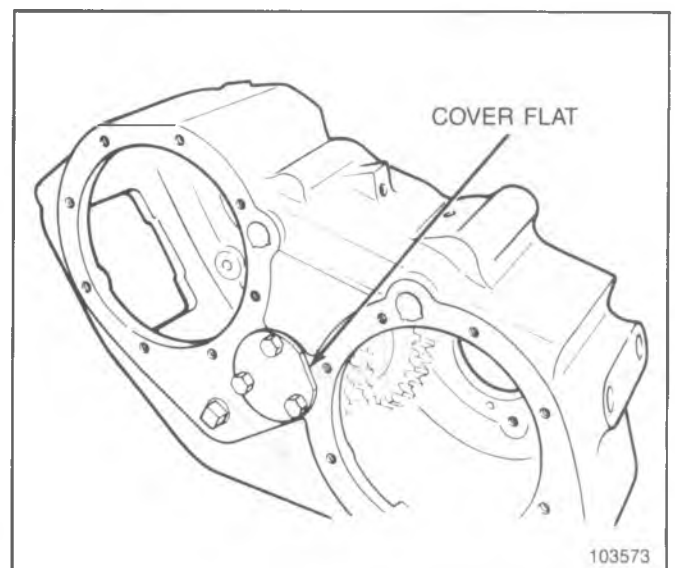

Fig. 7E-55--Installing Idler Shaft Rear Cover

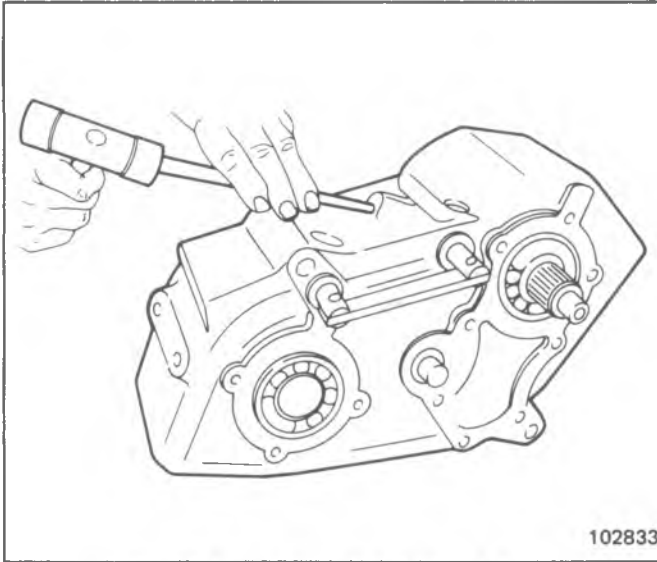

Fig. 7E-56--Installing Shift Rail Lock Pins

gear facing down and install thrust washer pin, thrust washer and new snap ring using Tool J-23432. Position the snap ring so that the opening is opposite the pin.

3. Position front wheel hi-gear and washer in case. Install synchronizer in the shift fork, then put fork and rail in the front wheel drive (4-H) position with the clutch teeth in mesh with the teeth of the front wheel hi-gear.
4. Line up washer, high gear, and synchronizer with bearing bore. Insert front output shaft and low gear assembly through the high gear assembly.
5. Install new seal in bearing retainer using Tool J-22836 (Fig. 7E-57) and install the front output bearing and retainer in the case.
6. Clean and grease rollers in front output rear bearing retainer. Install onto case using one gasket. Dip bolts into sealant. Install bolts and to 40 N·m (30 ft. lb.).
7. Install front output yoke, washer and lock nut. Torque nut to 202 N·m (150 ft. lb.).

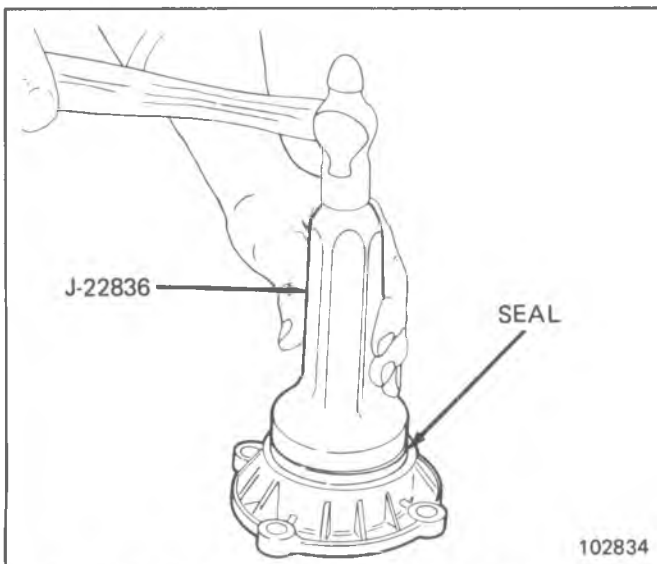

Fig. 7E-57--Installing Front Output Bearing Retainer Seal

### Rear Output Shaft Assembly

1. Install two rows of needle bearings (32 each) separated by a spacer into the output low gear. Use sufficient grease to retain needles.
2. Install thrust washer onto rear output shaft, tang down in clutch gear groove. Install output low gear onto shaft with clutch teeth facing down.
3. Install thrust washer over gear with tab pointing up and away from gear. Install washer pin and also large thrust washer over shaft and pin. Rotate washer until tab fits into slot approximately 90 degrees away from pin. Finally, install snap ring using Tool J-23423 and J-23423-1 and check end play which should be within 0.002 to 0.027 in..
4. Grease pilot bore or rear output shaft and install needle bearings (15). Install thrust washer and new snap ring in bore.
5. Clean, grease, and install new bearing in retainer housing using Tool J-23431 (Fig. 7E-58).
6. Install housing onto output shaft assembly, install spacer and speedometer gear, then install bearing (Fig. 7E-59).
7. Install rear bearing retainer seal using Tool J-21359 or J-22834-2 (Fig. 7E-60).
8. Install bearing retainer assembly onto housing with one or two gaskets, depending on clearance. Torque bolts to 40 N·m (30 ft. lb.).
9. Install yoke, washer, and lock nut output shaft.
10. Position range rail in "high" and install output shaft and retainer assembly on transfer case. Torque housing bolts to 40 N·m (30 ft. lb.).

### Miscellaneous

1. Install PTO cover and gasket. Torque bolts to 20 N·m (15 ft. lb.).
2. Install and seal cup plugs at rail pin holes, if not previously done.
3. Install drain and filler plugs and torque to 40 N·m (30 ft. lb.).
4. Install shift rail cross link, clevis pins and lock pins.

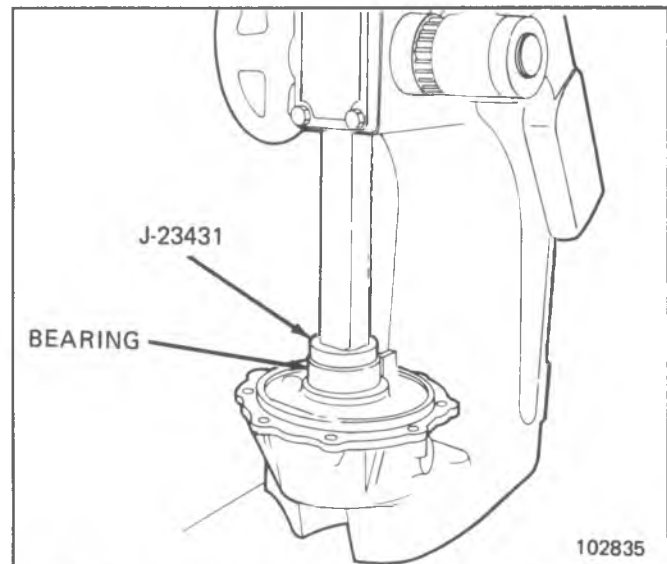

Fig. 7E-58--Installing Rear Output Shaft Housing Bearing



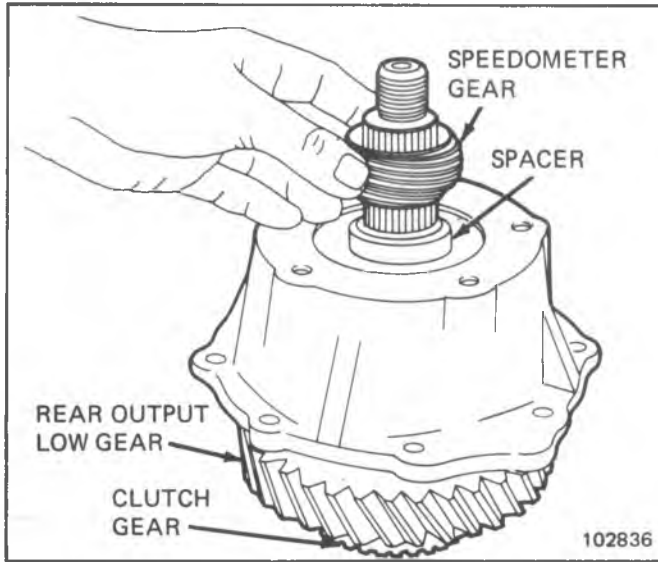

Fig. 7E-59--Installing Rear Output Shaft Spacer and Speedometer Gear

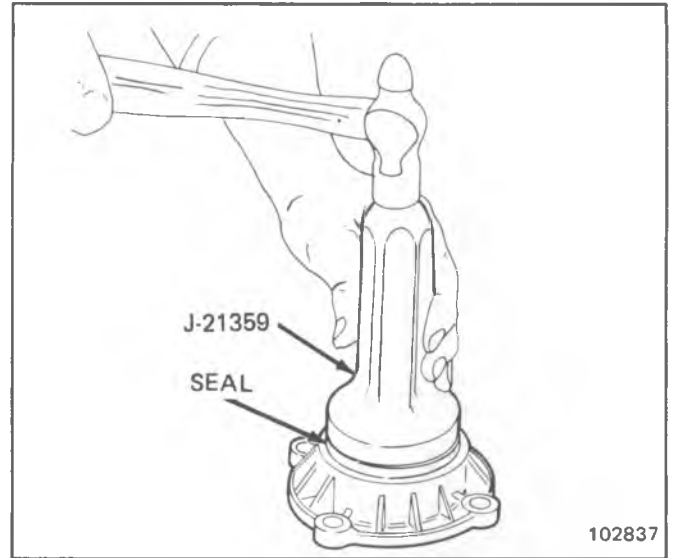

Fig. 7E-60--Installing Rear Bearing Retainer Seal



|   | N·m<br>MODEL 205 |
|---|------------------|
| NUT, SHIFT LEVER-TO-SHIFTER ASSEMBLY    | —                |
| NUT, KNOB ASSEMBLY-TO-SHIFT LEVER       | 26-40            |
| BOLT, SHIFTER ASSEMBLY-TO-TRANSFER CASE | 120-150          |
| NUT, SHIFT ARMS-TO-CASE                 | 14-20            |
| SCREW, SHIFT LEVER BOOT RETAINER        | 2.2-3.2          |
| BOLT, ADAPTER-TO-TRANSMISSION           | 26-40            |
| BOLT, ADAPTER-TO-TRANSFER CASE          | 26-40            |
| FILLER PLUG                             | 40-48            |
| BOLTS P.T.O. COVER                      | 20-24            |
| NUT, SKID PLATE-TO-CROSSMEMBER          | 55-70            |
| BOLT, SUPPORT STRUT ROD                 |                  |
| — TRANSMISSION END                      | 40-54            |
| — TRANSFER CASE END                     | 150-200          |

| MODEL NO.   | 205 (PART TIME)  |
|---|--|
| <b>AVAILABILITY</b>                                 | ALL K30 SERIES   |
| <b>RATIOS:</b> HI RANGE<br>LO RANGE                 | 1.00 TO 1<br>1.96 TO 1   |
| <b>LEVER POSITIONS</b>                              | 4-LO (ALL WHEEL UNDERDRIVE)<br>N (NEUTRAL)<br>2-HI (REAR WHEEL DRIVE)<br>4-HI (ALL WHEEL DIRECT DRIVE) |
| <b>LEVER LOCATION</b>                               | REAR OF TRANSMISSION SHIFT LEVER   |
| <b>POWER TAKE-OFF DATA:</b><br>OPENING AND LOCATION | SAE 6-BOLT; LEFT SIDE  |
| <b>LUBRICANTS:</b><br>OIL CAPACITY                  | 5.2 PINTS*   |
| TYPE, GRADE   | SEE OWNER'S MANUAL   |

\*TO BE FILLED WITHIN ONE INCH OF FILL PLUG.

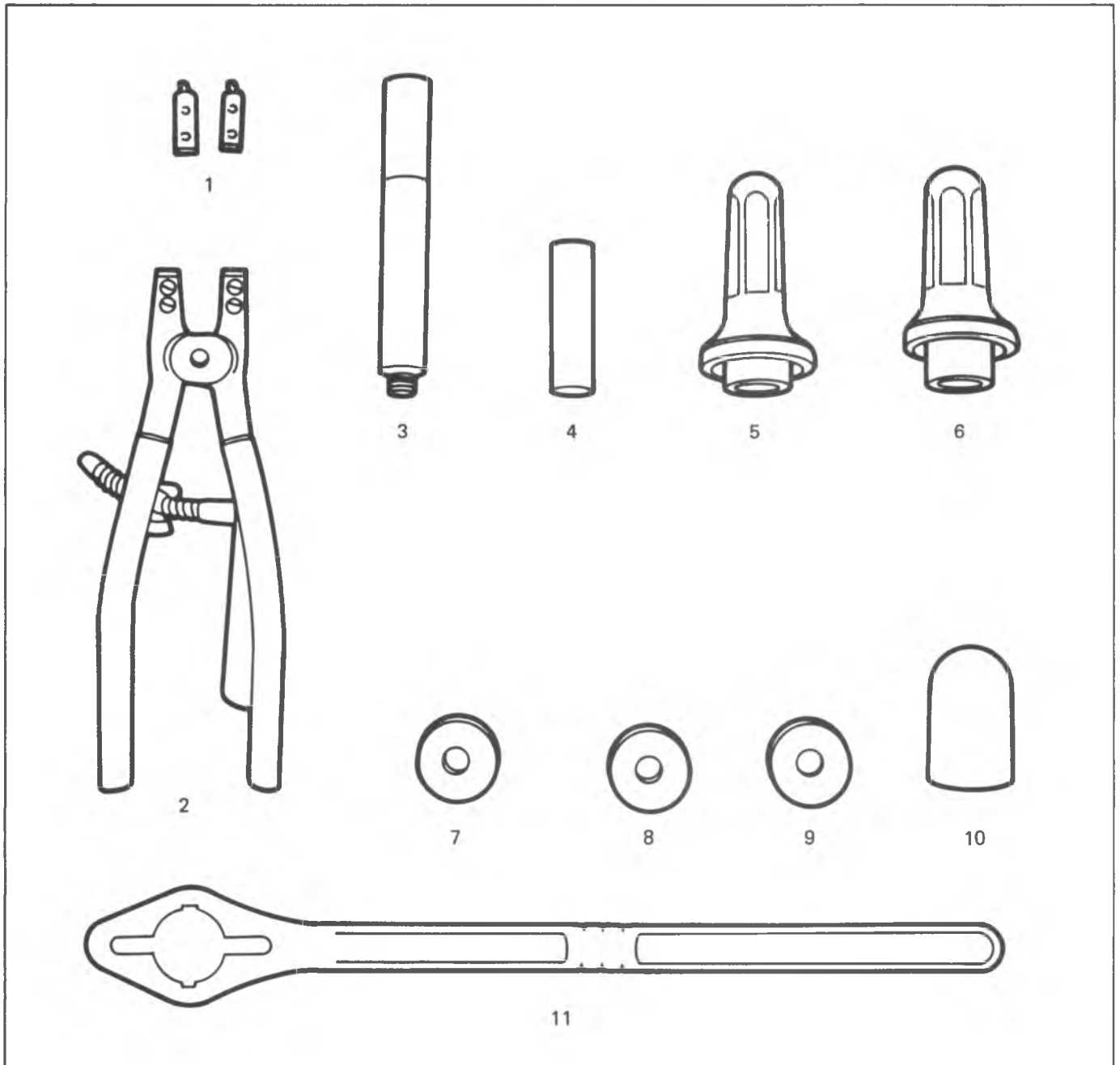

- |     |           |  |
|-----|-----------|--|
| 1.  | J-23432-1 | Snap Ring Picks.   |
| 2.  | J-23432   | Snap Ring Pliers.  |
| 3.  | J-8092    | Handle.  |
| 4.  | J-23429   | Intermediate Shaft Remover and Installer.                |
| 5.  | J-22836   | Front Output Shaft Bearing Retainer Seal Installer.      |
| 6.  | J-21359   | Rear Output Shaft Bearing Retainer Seal Installer.       |
| 7.  | J-23431   | Rear Output Shaft Housing Bearing Remover and Installer. |
| 8.  | J-8611-01 | Adapter Seal Installer.                                  |
| 9.  | J-9276-2  | Intermediate Gear Bearing Cup Installer.                 |
| 10. | J-22875   | Rear Output Shaft Rear Bearing Installer.                |
| 11. | J-8614-1  | Companion Flange Remover.                                |

Fig. 7E-ST2--205--Special Tools



# 208 TRANSFER CASE

## CONTENTS

|  |    |
|--|----|
| Model 208 Transfer Case (10 and 20 Series) |    |
| General Description .....                  | 1  |
| Diagnosis .....                            | 3  |
| Maintenance and Adjustments .....          | 3  |
| Skid Plate .....                           | 5  |
| Strut Rod .....                            | 5  |
| Adapter Assemblies .....                   | 6  |
| On Vehicle Service .....                   | 8  |
| Transfer Case .....                        | 8  |
| Unit Repair .....                          | 10 |
| Disassembly .....                          | 10 |
| Cleaning and Inspection .....              | 10 |
| Subassembly Overhaul .....                 | 11 |
| Assembly .....                             | 15 |

## GENERAL DESCRIPTION

The Model 208 transfer case (as shown in Fig. 7E-1) is an aluminum case, chain drive, four position unit providing four-wheel drive high and low ranges, a two-wheel high range, and a neutral position. The model 208 is a part-time four-wheel drive unit. Torque input in four-wheel high and low ranges is undifferentiated. The range positions on the Model 208 are selected by a floor mounted gearshift lever.

The Model 208 case is a two-piece aluminum case containing front and rear output shafts, two drive sprockets, a shift mechanism and a planetary gear assembly. The drive sprockets are connected and operated by the drive chain. The planetary assembly which consists of a four pinion carrier and an annulus gear provide the four-wheel drive low range when engaged. Reduction ratio is 2.61:1 in this range.

### Shift Pattern

A floor mounted shift lever is used to select the various operating ranges on the 208 model. The shift lever is located on the floorpan transmission tunnel adjacent to the transmission gearshift lever. Furthermore, the transfer case shift pattern is not in a straight line for 208 models, the range positions are shown in Fig. 7E-2.

### Four-Wheel Drive Indicator Lamp

An indicator lamp is mounted in the instrument panel to alert the driver whenever the vehicle is being operated in four-wheel range. The lamp is controlled by an indicator switch in the transfer case (Fig. 7E-3). The switch is a ball and plunger unit that is activated by the transfer case range sector when four-wheel range is selected.

### Identification

An identification tag is attached to the rear half of the transfer case (Fig. 7E-3). This tag provides the transfer case model number, low range reduction ratio, and assembly number. The information on this tag is necessary for servicing information. If the tag is removed or becomes dislodged during service operations, it should be reattached using an adhesive sealant such as Loctite 312, or equivalent.

### Lubrication

The Model 208 transfer case lubricant should be changed at the intervals specified in the Maintenance Schedule. When adding lubricant to or refilling the transfer case after service, use Dexron<sup>®</sup> II. Refer to the maintenance and adjustments section for lubricant change procedures and fill level.

### Power Flow

In all drive range positions input torque is transmitted to the transfer case gear train through the transfer case input gear.

In 2H range, torque flows from the input gear to the planetary assembly and annulus gear which rotate as a unit. Torque is transferred to the mainshaft through the planetary carrier which is splined to the mainshaft. Torque flow continues through the mainshaft and rear yoke which is splined to the mainshaft, and finally to the rear propeller shaft and axle. In 2H range, the sliding clutch remains in a neutral position and does not lock the drive sprocket to the mainshaft. As a result, torque is not transferred to the driven sprocket.

In 4H range, input torque from the input gear is

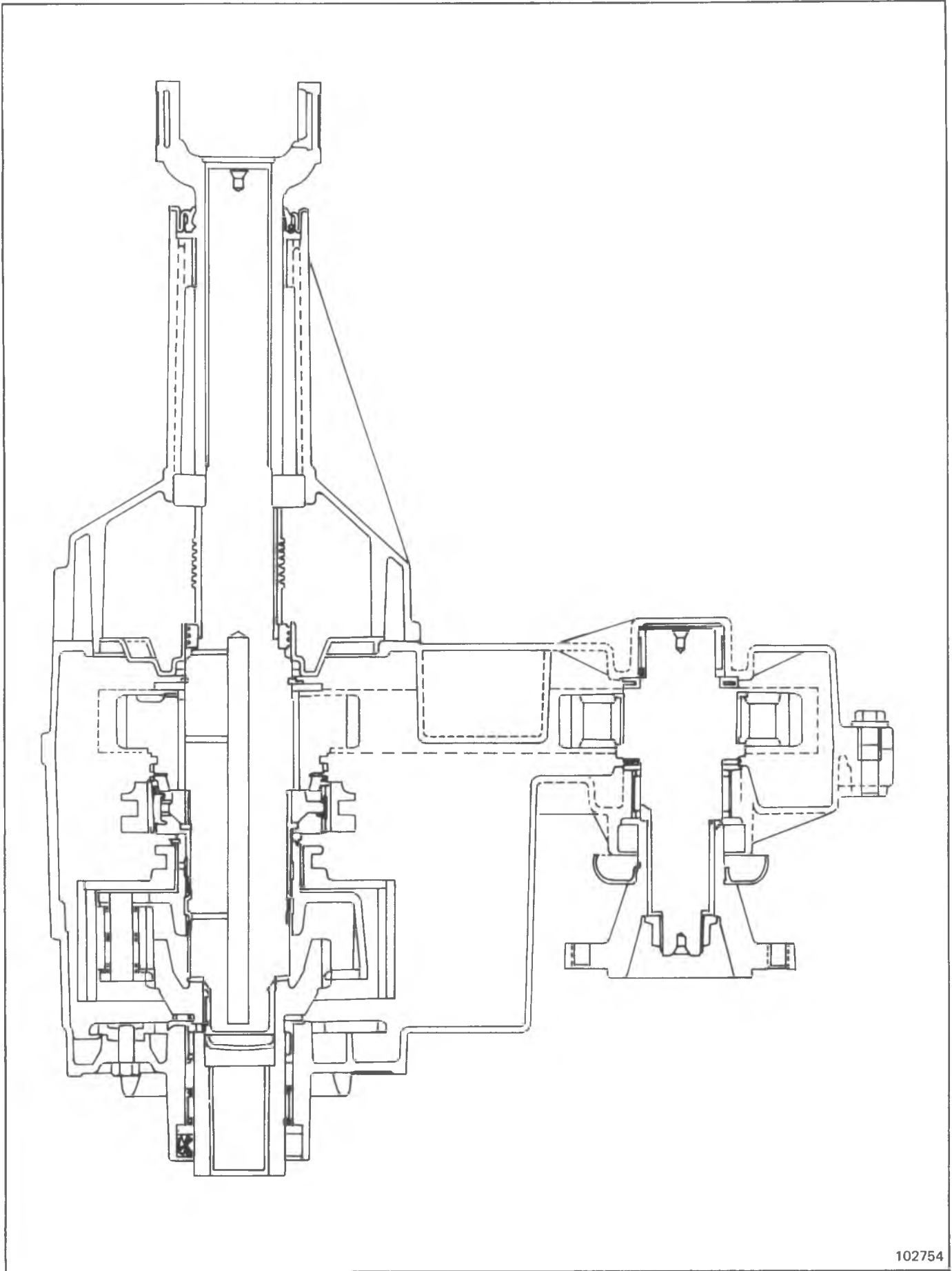

102754

Fig. 7E-1 Model 208 Transfer Case (Cross Section)

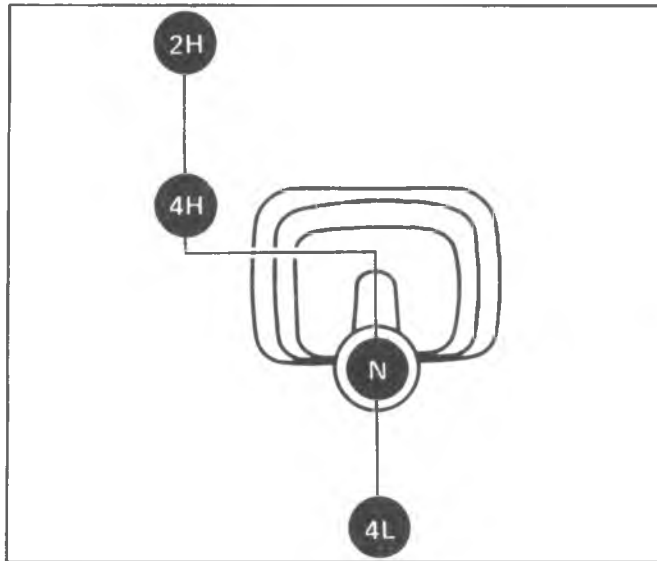

Fig. 7E-2 Model 208 Shift Pattern

transmitted through the planetary and annulus gear and through the mainshaft in exactly the same fashion as in 2H range. However, in 4H position, the sliding clutch is shifted forward and into engagement with the mainshaft clutch gear. This locks the drive sprocket to the mainshaft through the sliding clutch. Torque is now transmitted through the drive sprocket to the driven sprocket by the connecting driven chain. Since the front output shaft is splined to the driven sprocket, torque now flows through the front output shaft to the front propeller shaft and axle

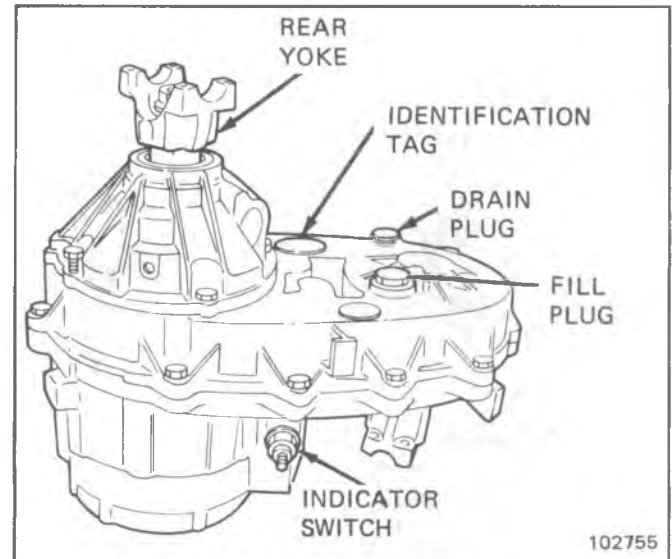

Fig. 7E-3 Model 208 Indicator Switch, Identification Tag, and Drain and Fill Plug Location

resulting in high range four-wheel drive.

In 4L range, the path of torque through the transfer case is exactly the same as in 4H range but with one major difference. In 4L range, the annulus gear is shifted forward and into engagement with the lock plate. Since the lock plate is fixed in the case, the annulus gear is held stationary and does not rotate. This causes the planetary pinions to rotate about the annulus gear internal teeth producing a gear reduction ratio of 2.61:1.

## SERVICE DIAGNOSIS

### GENERAL

Before attempting to repair a suspected transfer case malfunction, check all other driveline components. The actual cause of a problem may be related to such items as

the front hubs, axles, propeller shafts, wheels and tires, transmission, or clutch instead. If all other driveline components are in good condition and operating properly, refer to the Service Diagnosis Chart for further information.

## MAINTENANCE AND ADJUSTMENTS

### CASE-OIL CHANGE

1. Raise vehicle.
2. Position drain pan under transfer case.
3. Remove drain and fill plugs and drain lubricant.
4. Install drain plug. Tighten plug to 24 N·m (18 ft. lb.).
5. Remove drain pan.
6. Fill transfer case to edge of fill plug opening with Dexron® II.

7. Install fill plug. Tighten plug to 24 N·m (18 ft. lb.).
8. Lower vehicle.

### LINKAGE ADJUSTMENT AND INSPECTION (Fig. 7E-4)

The control linkages and attachments for the 208 transfer case are shown in Fig. 7E-4 and 7E-5.

Periodically inspect the linkage system for freedom of operation, proper engagement, loose attaching bolts, foreign material, etc. Adjust, clean and tighten as necessary.

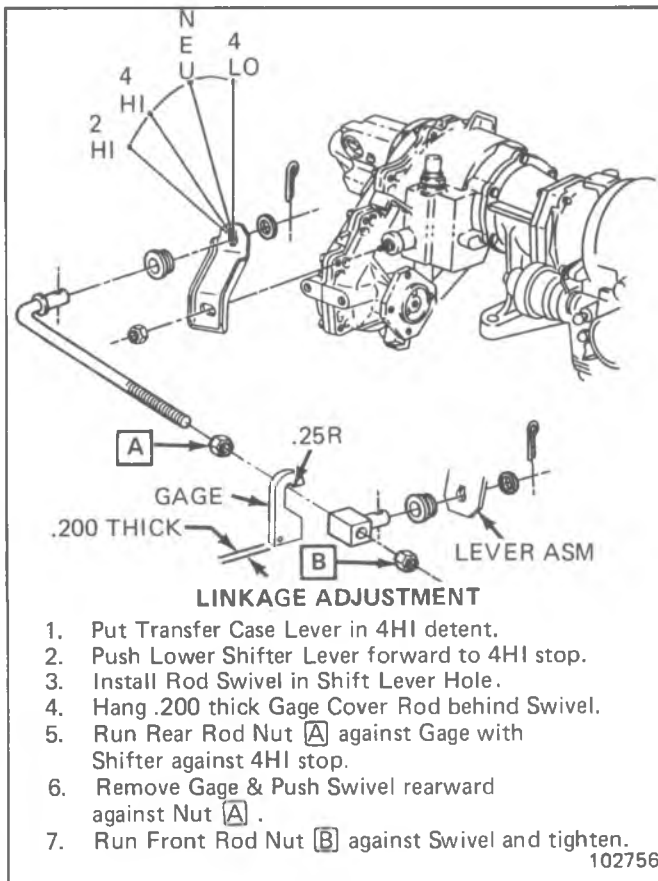

Fig. 7E-4--Linkage Adjustment

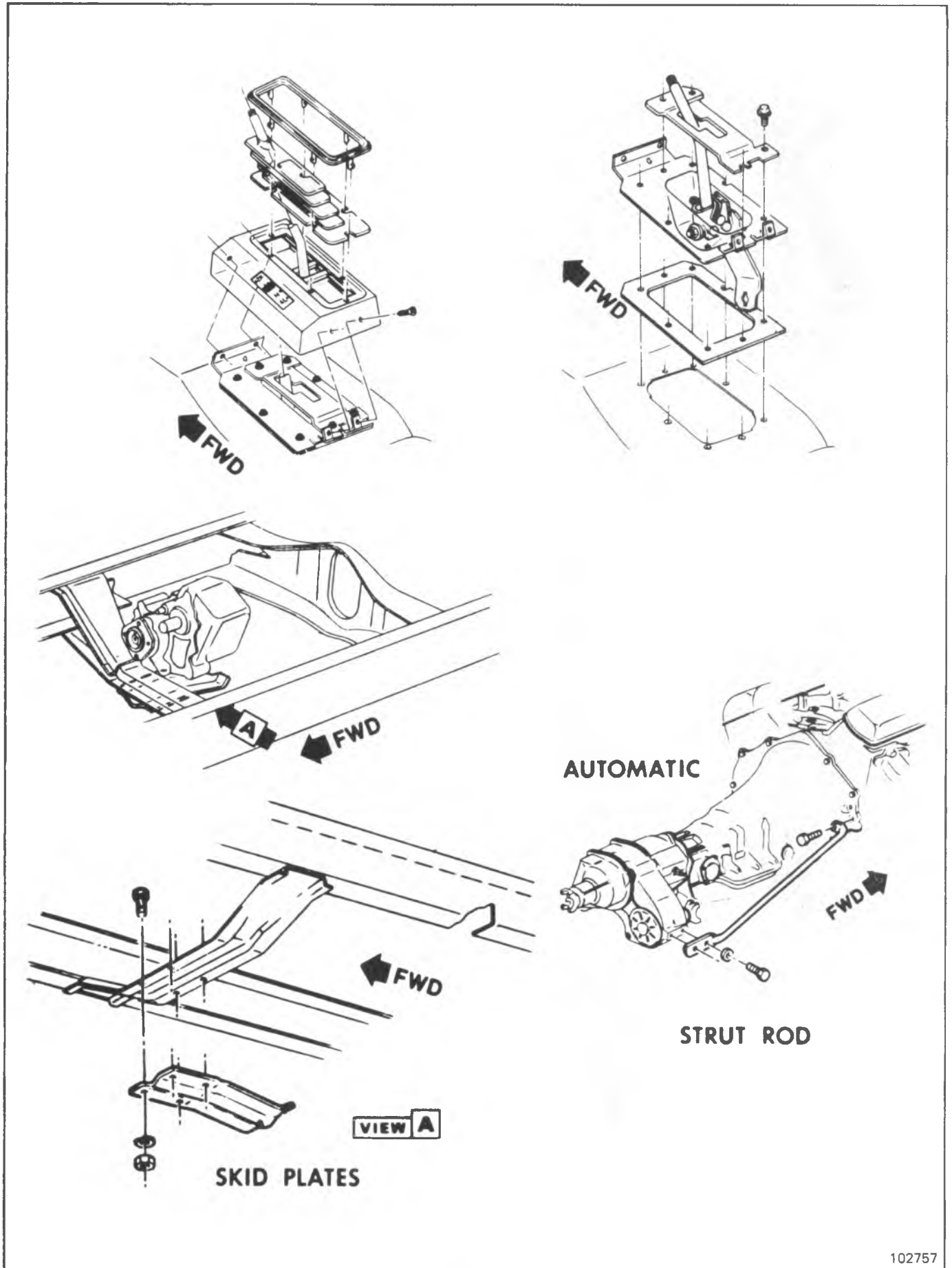
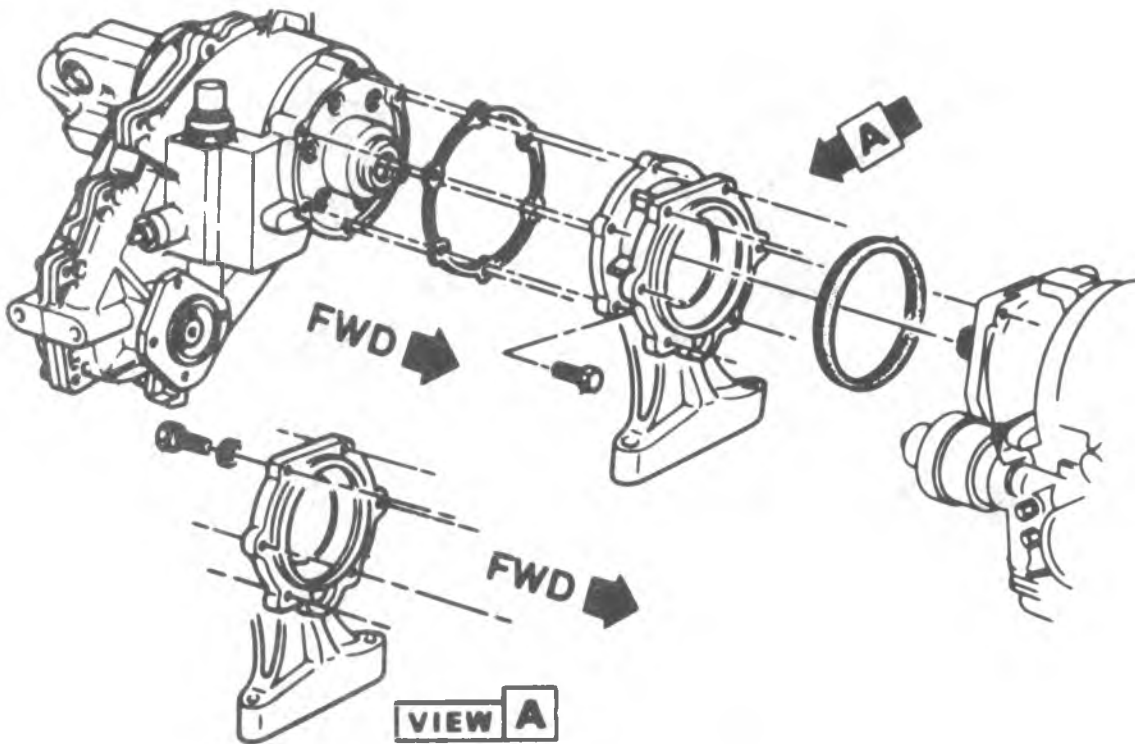
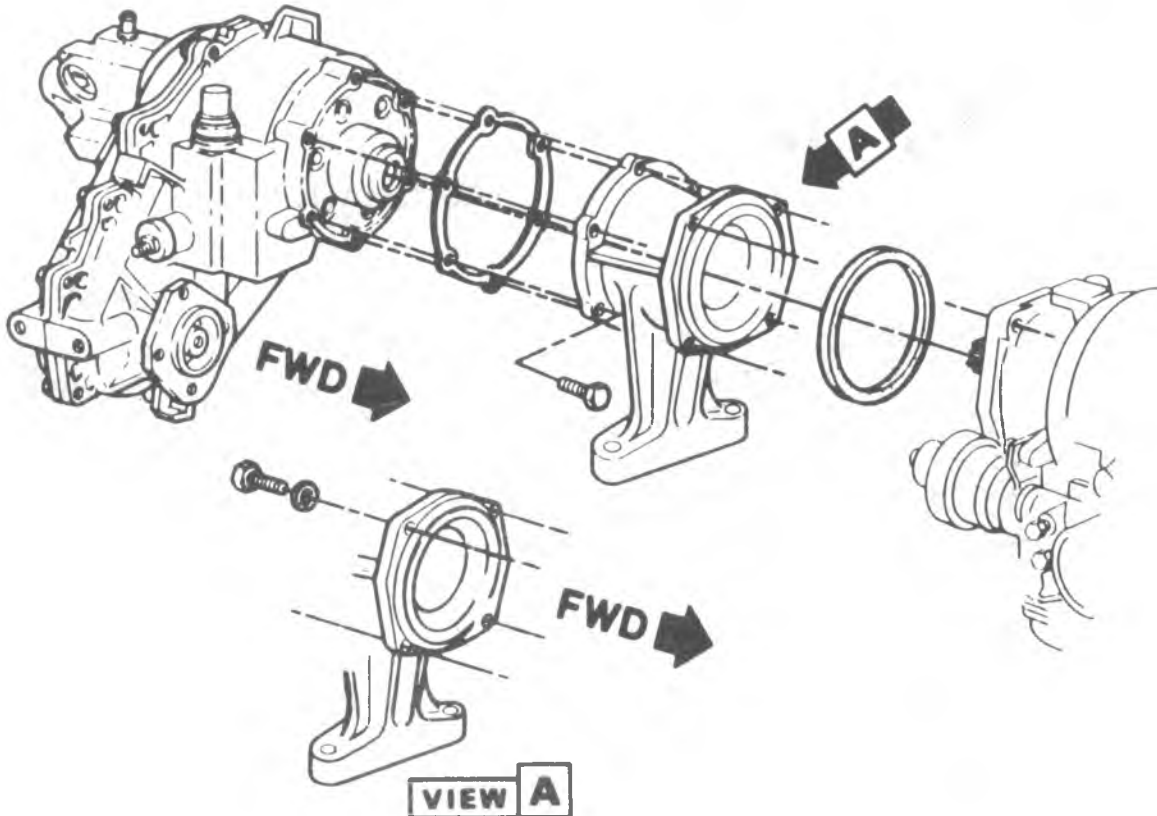

Fig. 7E-5 Transfer Case Shifter, Skid Plates and Strut Rods





WITH AUTOMATIC TRANSMISSION



WITH MANUAL TRANSMISSION

Fig. 7E-6 Transfer Case Attachments

| <b>Service Diagnosis</b>  |  |   |
|---|--|---|
| <b>Condition</b>  | <b>Possible Cause</b>  | <b>Correction</b>   |
| TRANSFER CASE<br>DIFFICULT TO SHIFT<br>OR WILL NOT SHIFT<br>INTO DESIRED<br>RANGE | <ul style="list-style-type: none"> <li>(1) Vehicle speed too great to permit shifting.</li> <li>(2) If vehicle was operated for extended period in 4H mode on dry paved surface, driveline torque load may cause difficult shifting.</li> <li>(3) Transfer case external shift linkage binding.</li> <li>(4) Insufficient or incorrect lubricant.</li> <li>(5) Internal components binding, worn, or damaged.</li> </ul> | <ul style="list-style-type: none"> <li>(1) Stop vehicle and shift into desired range. Or reduce speed to 2-3 mph (3-4 km/h) before attempting to shift.</li> <li>(2) Stop vehicle, shift transmission to neutral, shift transfer case to 2H mode and operate vehicle in 2H on dry paved surfaces.</li> <li>(3) Lubricate or repair or replace linkage, or tighten loose components as necessary.</li> <li>(4) Drain and refill to edge of fill hole with DEXRON®-II only.</li> <li>(5) Disassemble unit and replace worn or damaged components as necessary.</li> </ul> |
| TRANSFER CASE<br>NOISY IN ALL DRIVE<br>MODES                                      | <ul style="list-style-type: none"> <li>(1) Insufficient or incorrect lubricant.</li> </ul>   | <ul style="list-style-type: none"> <li>(1) Drain and refill to edge of fill hole with DEXRON®-II only. Check for leaks and repair if necessary. Note: If unit is still noisy after drain and refill, disassembly and inspection may be required to locate source of noise.</li> </ul>   |
| NOISY IN – OR JUMPS<br>OUT OF FOUR WHEEL<br>DRIVE LOW RANGE                       | <ul style="list-style-type: none"> <li>(1) Transfer case not completely engaged in 4L position.</li> <li>(2) Shift linkage loose or binding.</li> <li>(3) Range fork cracked, inserts worn, or fork is binding on shift rail.</li> <li>(4) Annulus gear or lockplate worn or damaged.</li> </ul>   | <ul style="list-style-type: none"> <li>(1) Stop vehicle, shift transfer case in Neutral, then shift back into 4L position.</li> <li>(2) Tighten, lubricate, or repair linkage as necessary.</li> <li>(3) Disassemble unit and repair as necessary.</li> <li>(4) Disassemble unit and repair as necessary.</li> </ul>  |
| LUBRICANT LEAKING<br>FROM OUTPUT SHAFT<br>SEALS OR FROM<br>VENT                   | <ul style="list-style-type: none"> <li>(1) Transfer case overfilled.</li> <li>(2) Vent closed or restricted.</li> <li>(3) Output shaft seals damaged or installed incorrectly.</li> </ul>  | <ul style="list-style-type: none"> <li>(1) Drain to correct level.</li> <li>(2) Clear or replace vent if necessary.</li> <li>(3) Replace seals. Be sure seal lip faces interior of case when installed. Also be sure yoke seal surfaces are not scored or nicked. Remove scores, nicks with fine sandpaper or replace yoke(s) if necessary.</li> </ul>  |
| ABNORMAL TIRE<br>WEAR   | <ul style="list-style-type: none"> <li>(1) Extended operation on dry hard surface (paved) roads in 4H range.</li> </ul>  | <ul style="list-style-type: none"> <li>(1) Operate in 2H on hard surface (paved) roads.</li> </ul>  |

Fig. 7E-7-Service Diagnosis Chart

## ON VEHICLE SERVICE

### TRANSFER CASE

#### Removal

1. Place transfer case in 4H.
2. Raise vehicle.
3. Drain lubricant from transfer case.
4. Remove cotter pin from shift lever swivel.
5. Mark transfer case front and rear output shaft yokes and propeller shafts for assembly alignment reference.
6. Disconnect speedometer cable and indicator switch wires.
7. Disconnect front propeller shaft at transfer case yoke.
8. Disconnect parking brake cable guide from pivot located on right frame rail, if necessary.
9. Remove engine strut rod from transfer case on automatic transmission models.
10. Place support under transfer case and remove transfer case-to-transmission adapter bolts.
11. Move transfer case assembly rearward until free of transmission output shaft and remove assembly.
12. Remove all gasket material from rear of transmission adapter housing.

#### Installation

1. Install transmission-to-transfer case gasket on transmission.
2. Shift transfer case to 4H position if not done previously.
3. Rotate transfer case output shaft (by turning yoke) until transmission output shaft gear engages transfer case input shaft. Move transfer case forward until case seats against transmission. Be sure the transfer case is flush against the transmission. Severe damage to the transfer case will result if the attaching bolts are tightened while the transfer case is cocked or in a bind.
4. Install transfer case attaching bolts. Tighten bolts to 41 N·m (30 ft. lb.).
5. Connect speedometer driven gear to transfer case.
6. Connect front and rear propeller shafts to transfer case. Be sure to align shafts-to-yokes using reference marks made during removal. Tighten shaft-to-yoke clamp strap nuts to 20 N·m (15 ft. lb.).
7. Remove support stand from under transfer case.
8. Connect parking brake cable if disconnected.
9. Attach cotter pin to shift lever swivel.
10. Connect engine strut to transfer case on automatic models.
11. Fill transfer case with Dexron®II.
12. Lower vehicle.

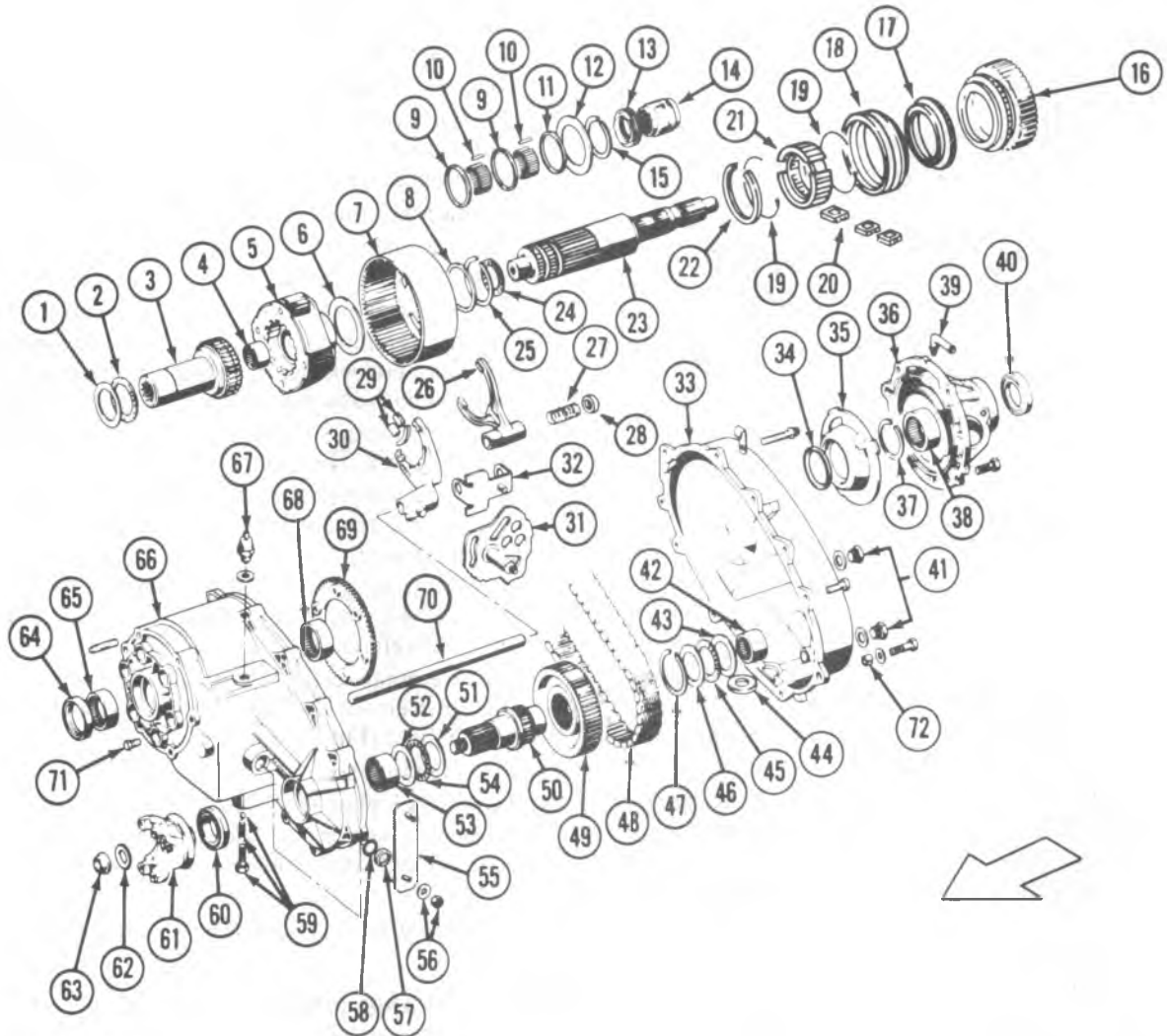

- |                                     |  |   |
|-------------------------------------|--|---|
| 1. INPUT GEAR THRUST WASHER         | 33. REAR CASE  | 57. RANGE SECTOR SHAFT SEAL RETAINER      |
| 2. INPUT GEAR THRUST BEARING        | 34. SEAL   | 58. RANGE SECTOR SHAFT SEAL               |
| 3. INPUT GEAR                       | 35. PUMP HOUSING   | 59. DETENT BALL, SPRING AND RETAINER BOLT |
| 4. MAINSHAFT PILOT BEARING          | 36. REAR RETAINER  | 60. FRONT SEAL                            |
| 5. PLANETARY ASSEMBLY               | 37. BEARING SNAP RING                                    | 61. FRONT YOKE                            |
| 6. PLANETARY THRUST WASHER          | 38. REAR OUTPUT BEARING                                  | 62. YOKE SEAL WASHER                      |
| 7. ANNULUS GEAR                     | 39. VENT TUBE  | 63. YOKE NUT                              |
| 8. ANNULUS GEAR THRUST WASHER       | 40. REAR SEAL  | 64. INPUT GEAR OIL SEAL                   |
| 9. NEEDLE BEARING SPACERS           | 41. DRAIN AND FILL PLUGS                                 | 65. INPUT GEAR FRONT BEARING              |
| 10. MAINSHAFT NEEDLE BEARINGS (120) | 42. FRONT OUTPUT SHAFT REAR BEARING                      | 66. FRONT CASE                            |
| 11. NEEDLE BEARING SPACER           | 43. FRONT OUTPUT SHAFT REAR THRUST BEARING RACE (THIN)   | 67. LOCK MODE INDICATOR SWITCH AND WASHER |
| 12. SPACER WASHER                   | 44. CASE MAGNET  | 68. INPUT GEAR REAR BEARING               |
| 13. OIL PUMP GEAR                   | 45. FRONT OUTPUT SHAFT REAR THRUST BEARING               | 69. LOCKPLATE                             |
| 14. SPEEDOMETER GEAR                | 46. FRONT OUTPUT SHAFT REAR THRUST BEARING RACE (THIN)   | 70. SHIFTER FORK SHAFT                    |
| 15. DRIVE SPROCKET SNAP RING        | 47. DRIVEN SPROCKET RETAINING RING                       | 71. LOCKPLATE BOLTS                       |
| 16. DRIVE SPROCKET                  | 48. DRIVE CHAIN  | 72. CASE ALIGNMENT DOWELS                 |
| 17. BLOCKER RING                    | 49. DRIVEN SPROCKET                                      |   |
| 18. SYNCHRONIZER SLEEVE             | 50. FRONT OUTPUT SHAFT                                   |   |
| 19. SYNCHRONIZER SPRING             | 51. FRONT OUTPUT SHAFT FRONT THRUST BEARING RACE (THIN)  |   |
| 20. SYNCHRONIZER KEY                | 52. FRONT OUTPUT SHAFT FRONT THRUST BEARING RACE (THICK) |   |
| 21. SYNCHRONIZER HUB                | 53. FRONT OUTPUT SHAFT FRONT BEARING                     |   |
| 22. SYNCHRONIZER HUB SNAP RING      | 54. FRONT OUTPUT SHAFT FRONT THRUST BEARING              |   |
| 23. MAINSHAFT                       | 55. OPERATING LEVER                                      |   |
| 24. MAINSHAFT THRUST BEARING        | 56. WASHER AND LOCKNUT                                   |   |
| 25. INTERNAL GEAR SNAP RING         |  |   |
| 26. MODE FORK                       |  |   |
| 27. SPRING                          |  |   |
| 28. SPRING RETAINER                 |  |   |
| 29. RANGE FORK PADS                 |  |   |
| 30. RANGE FORK                      |  |   |
| 31. RANGE SECTOR                    |  |   |
| 32. MODE FORK BRACKET               |  |   |

Fig. 7E-8-208 Transfer Case (Exploded View)

## UNIT REPAIR

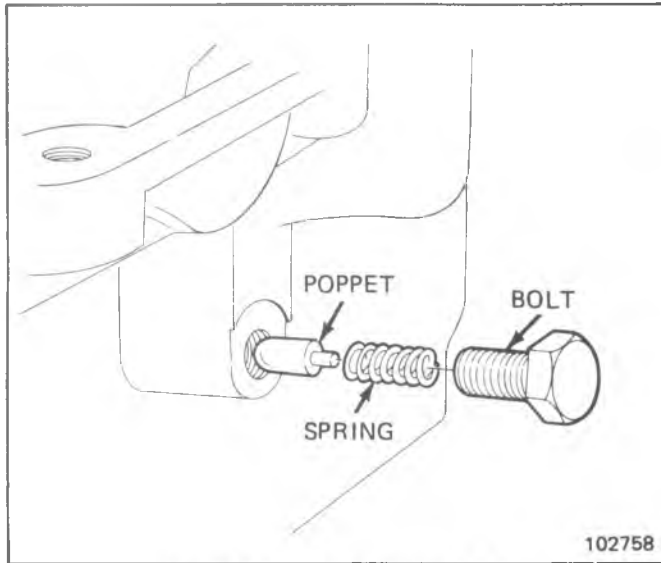

Fig. 7E-9-Poppet, Spring and Bolt

### TRANSFER CASE

#### Disassembly

1. Remove fill and drain plugs (Fig. 7E-8).
2. Remove front yoke. Discard yoke seal washer and yoke nut.
3. Turn transfer case on end and position front case on wood blocks. Cut "V" notches in wood blocks to clear mounting studs in front case if necessary.
4. Remove lock mode indicator switch and washer (Fig. 7E-8).
5. Remove detent bolt, spring and ball (Fig. 7E-9).
6. Remove rear retainer attaching bolts and remove retainer and pump housing as assembly (Fig. 7E-10). Tap retainer from case using plastic mallet only. DO NOT pry.
7. Remove pump housing from retainer and remove pump seal from housing (Fig. 7E-10). Discard seal.
8. Remove speedometer drive gear from mainshaft.
9. Remove oil pump from mainshaft. Note the position of pump for assembly reference. Side facing case interior has recess in it (Fig. 7E-11).
10. Remove bolts attaching rear case to front case and remove rear case. To remove the rear case, insert screwdrivers into the slots cast in the case ends and gently pry upward. DO NOT attempt to wedge the case halves apart at any point on the mating surfaces.
11. Remove retainer and spring from shift rod.
12. Remove front output shaft rear thrust bearing assembly (Fig. 7E-12). Note position of bearing and races for assembly reference.
13. Remove driven sprocket retaining snap ring (Fig. 7E-13).
14. Remove drive sprocket retaining snap ring and remove spacer washer (Fig. 7E-14).
15. Remove drive and driven sprockets and drive chain as assembly (Fig. 7E-15). Lift evenly on both sprockets to

remove assembly. Mainshaft roller bearings may drop out of driven sprocket.

16. Remove front output shaft and front thrust bearing assembly (Fig. 7E-16).
17. Remove synchronizer blocker ring (Fig. 7E-17).
18. Remove synchronizer, mode fork bushing, mode fork and bracket as assembly (Fig. 7E-18). The synchronizer keys may fall free from the hub.
19. Remove shift rail.
20. Remove mainshaft with synchronizer hub and snap ring attached (Fig. 7E-19).
21. Remove annulus gear snap ring and thrust washer.
22. Remove annulus gear and range fork as assembly. Turn fork counterclockwise to disengage fork lug from range sector and lift assembly out of case (Fig. 7E-20).
23. Remove planetary thrust washer and remove planetary assembly (Fig. 7E-21).
24. Remove mainshaft thrust bearing from input gear (Fig. 7E-22) and remove input gear. Lift gear straight up and out of case.
25. Remove input gear thrust bearing and race (Fig. 7E-23). NOTE the position of bearing and race for assembly reference.
26. Remove range sector operating lever attaching nut and washer. Remove lever and remove sector shaft seal and seal retainer (Fig. 7E-8).
27. Remove range sector.
28. Inspect lock plate (Fig. 7E-23). If lock plate is loose or is worn, broken or cracked, remove lock plate. Refer to replacement procedure in Subassembly Overhaul section.
29. Remove output shaft seals from front and rear case seal bores.

### CLEANING AND INSPECTION

Wash all parts thoroughly in clean solvent. Be sure all old lubricant, metallic particles, dirt, or foreign material

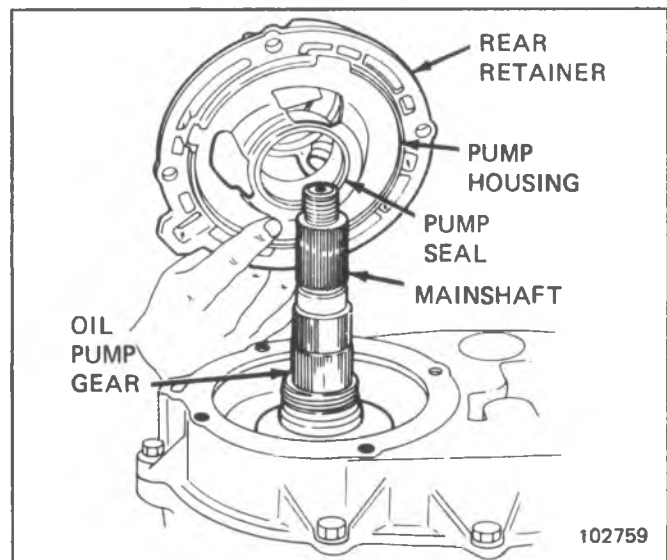

Fig. 7E-10-Rear Retainer

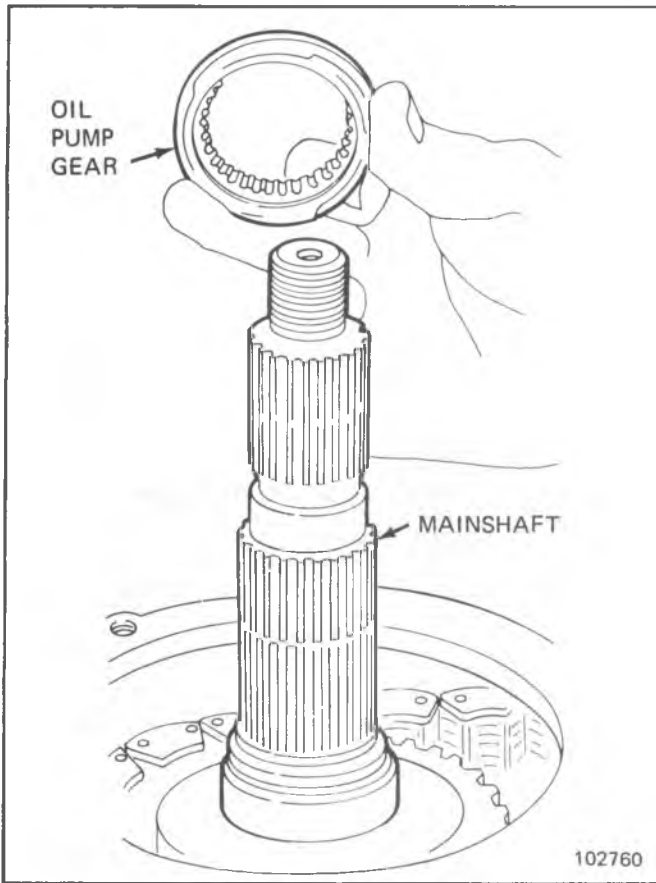

Fig. 7E-11-Oil Pump

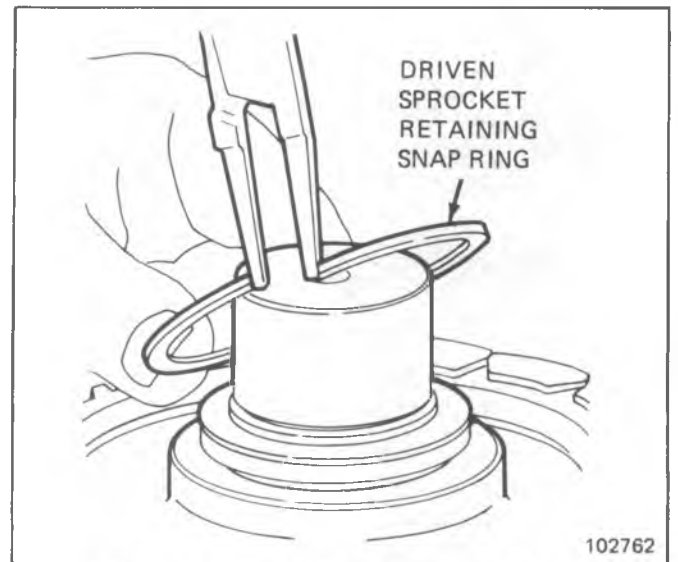

Fig. 7E-13-Driven Sprocket Retaining Snap Ring

are removed from the surfaces of every part. Apply compressed air to each oil feed port and channel in each case half to remove any obstructions or cleaning solvent residue.

Inspect all gear teeth for signs of excessive wear or damage and check all gear splines for burrs, nicks, wear or damage. Remove minor nicks or scratches on oil stone. Replace any part exhibiting excessive wear or damage.

Inspect all snap rings and thrust washers for evidence of excessive wear, distortion or damage. Replace any of

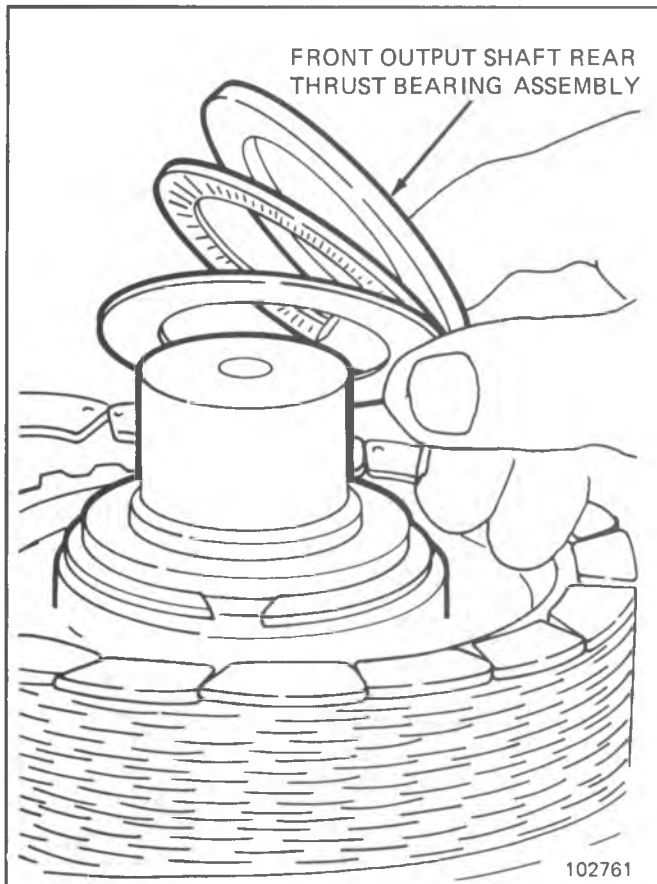

Fig. 7E-12-Front Output Shaft Rear Thrust Bearing

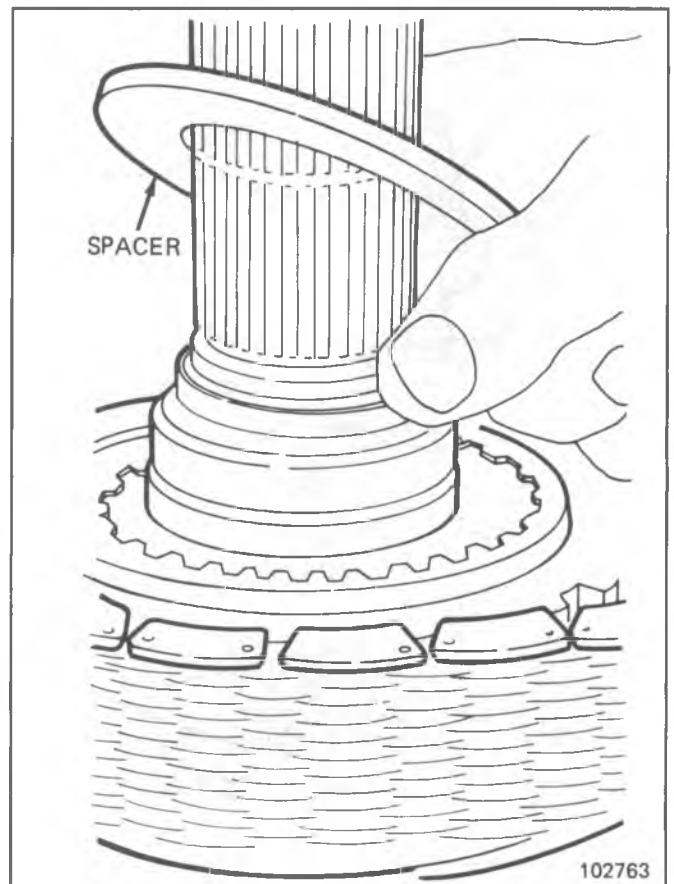

Fig. 7E-14-Drive Sprocket Thrust Washer

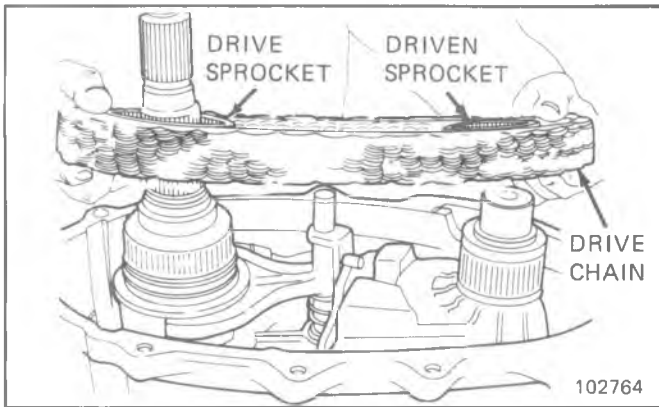

Fig. 7E-15-Sprocket and Chain

these parts if they exhibit these conditions.

Inspect the two case halves for cracks, porosity, damaged mating surfaces, stripped bolt threads, or distortion. Replace any part that exhibits these conditions. Inspect the low range lock plate in the front case. If the lock plate teeth or the plate hub is cracked, broken, chipped, or excessively worn, replace the lock plate and the lock plate attaching bolts. Refer to the Lock Plate Replacement procedure.

Inspect the condition of all needle, roller and thrust bearings in the front and rear case halves and the input gear. Also, check the condition of the bearing bores in both cases and in the input gear, rear output shaft, side gear, and rear retainer. Replace any part that exhibits signs of excessive wear or damage. If the case or input gear bearings require replacement, refer to Bearing Replacement.

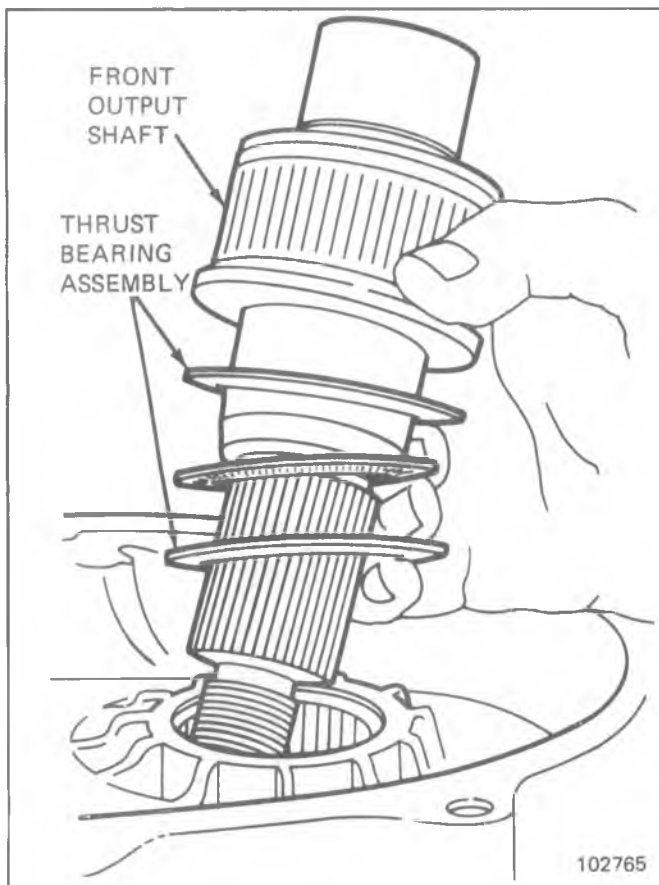

Fig. 7E-16-Front Output Shaft and Front Thrust Bearing Assembly

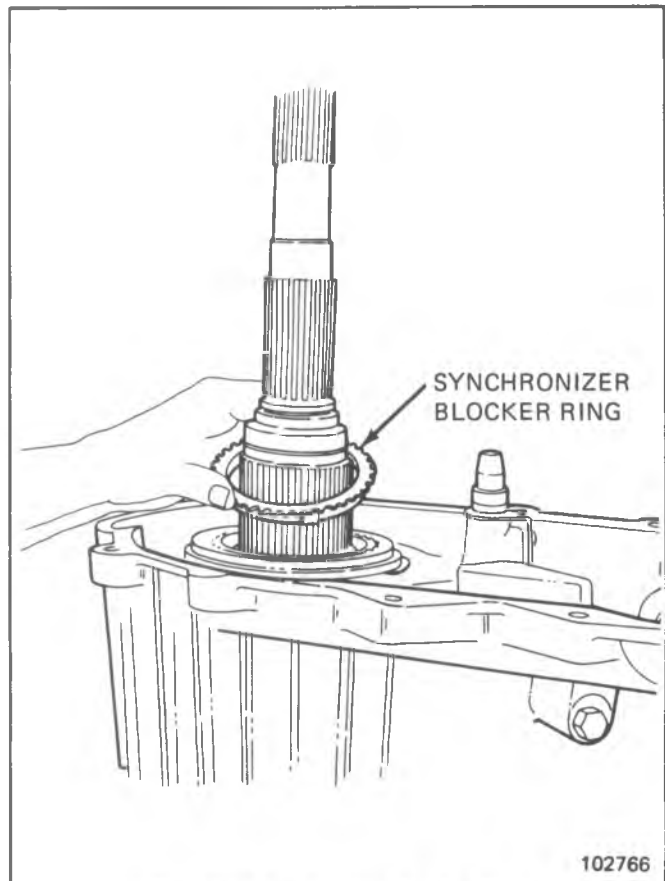

Fig. 7E-17-Synchronizer Blocker Ring

## SUBASSEMBLY OVERHAUL

### Lock Plate Replacement

1. Remove and discard lock plate attaching bolts.
2. Remove lock plate from case.
3. Coat case and lock plate surfaces around bolt holes with Loctite 515 sealant, or equivalent.
4. Position new lock plate in case and align bolt

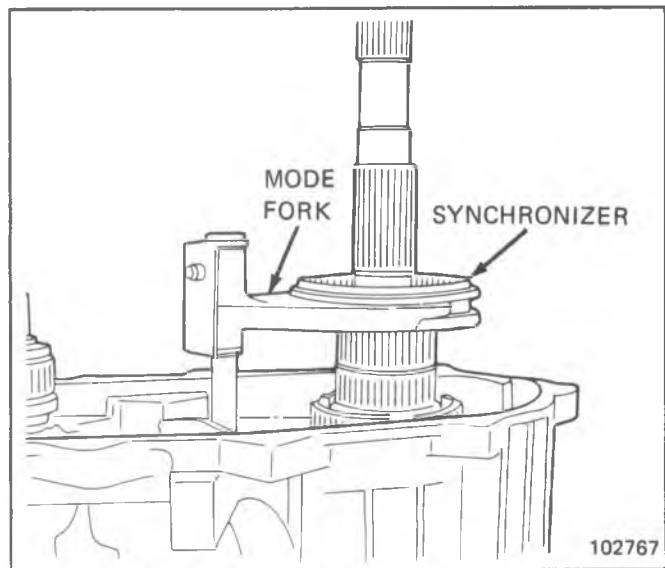

Fig. 7E-18-Synchronizer, Mode Fork Bushing, Mode Fork and Bracket



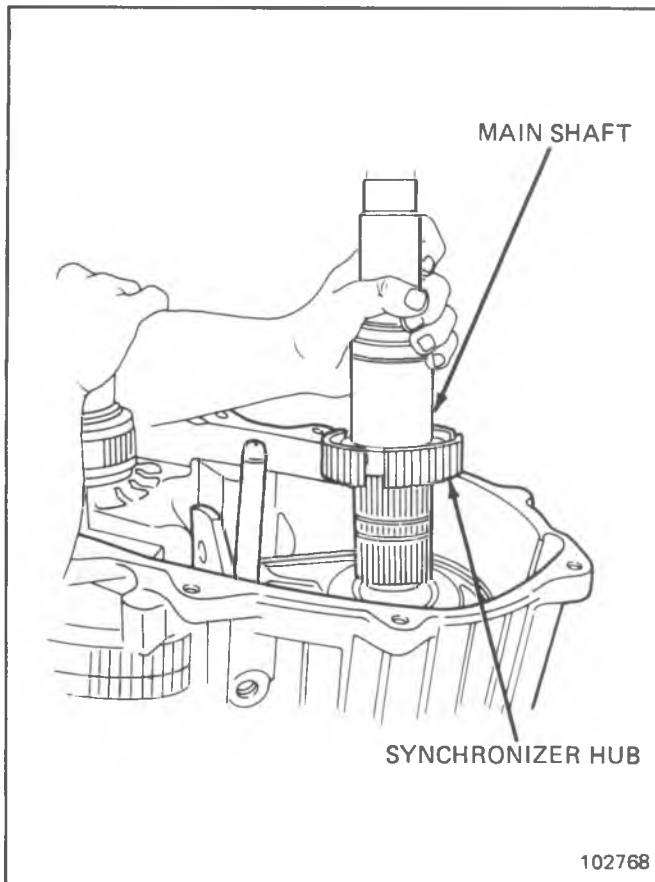

Fig. 7E-19-Mainshaft

holes in lock plate and case.

5. Coat new lock plate attaching bolts with Loctite 271 sealant, or equivalent.
6. Install and tighten lock plate attaching bolts to 41 N·m (30 ft. lb.).

**Bearing and Bushing Replacement**

All of the bearings used in the transfer case must be correctly positioned to avoid covering the bearing oil feed holes. After replacing any bearings check the bearing

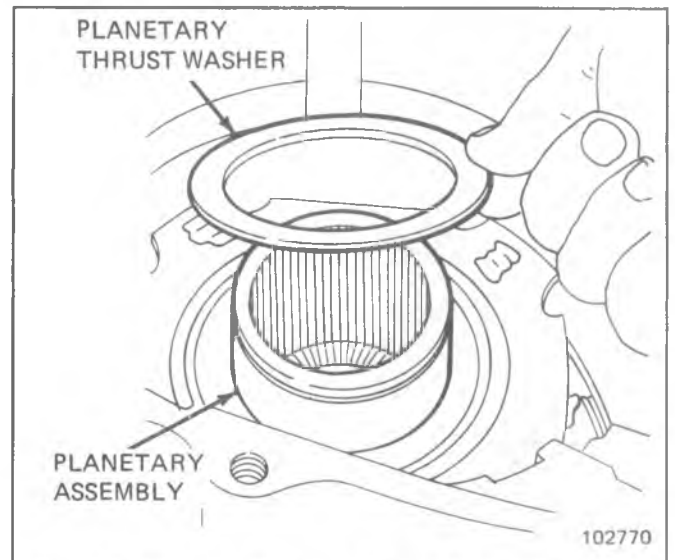

Fig. 7E-21-Planetary Thrust Washer and Planetary Assembly

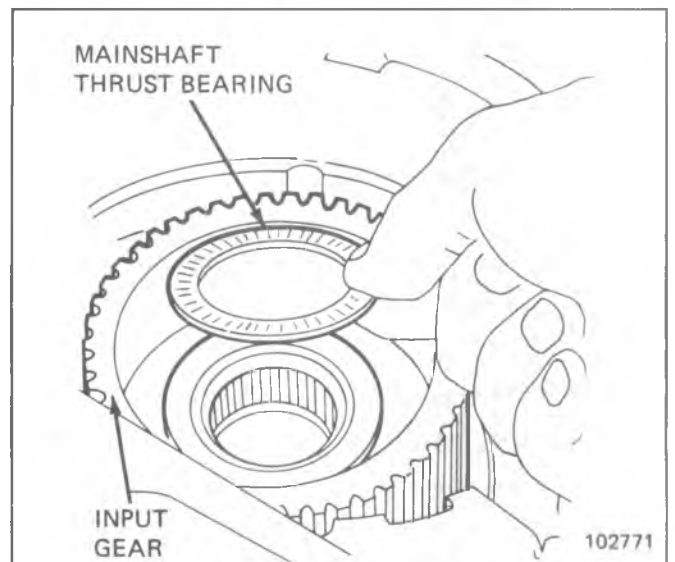

Fig. 7E-22-Mainshaft Thrust Bearing and Input Gear

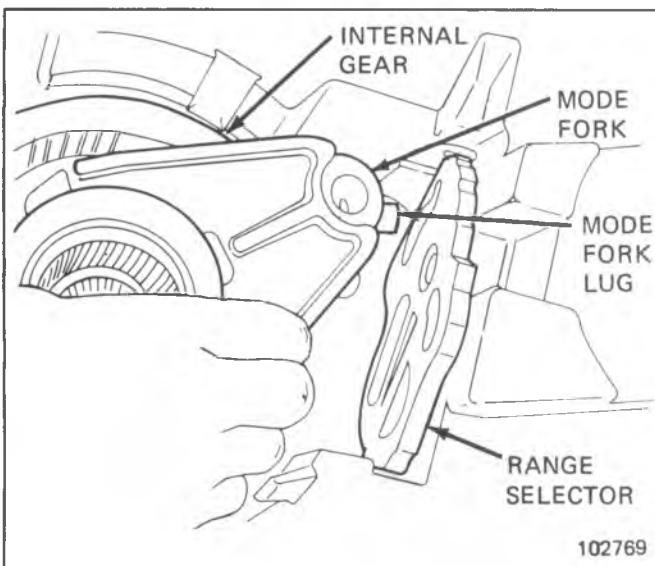

Fig. 7E-20-Annulus Gear and Mode Fork

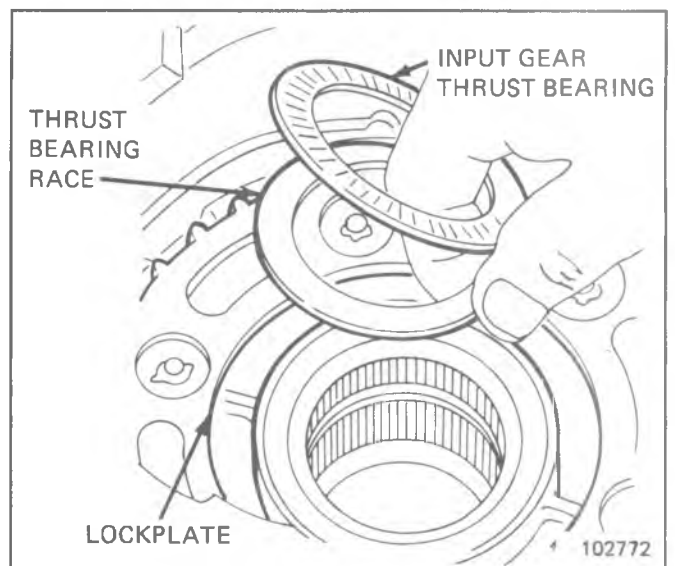

Fig. 7E-23-Input Gear Thrust Bearing and Race



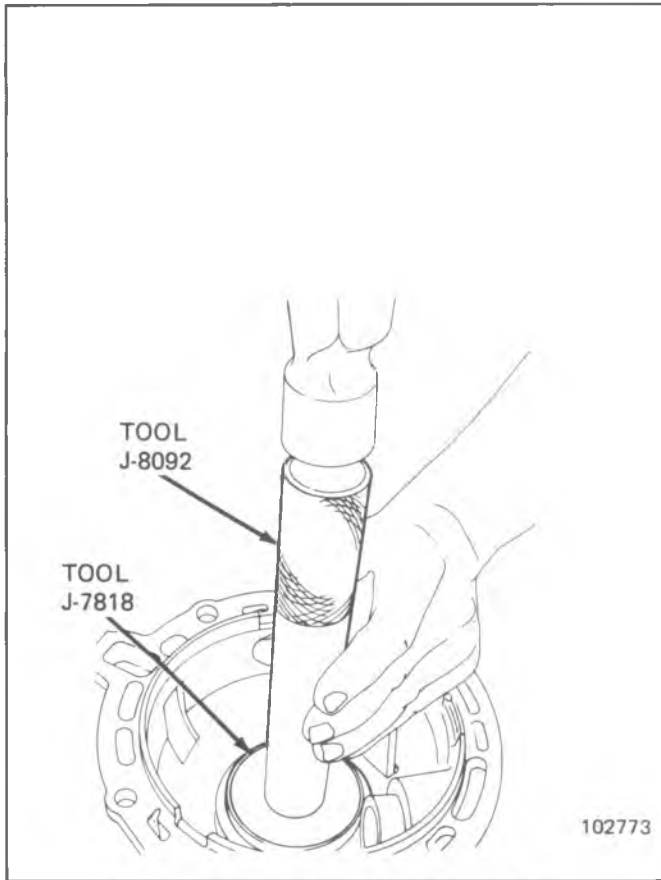

Fig. 7E-24-Rear Output Bearing Installation

position to be sure the feed hole is not obstructed or blocked by a bearing.

**Rear Output Bearing and Rear Seal Replacement**

1. Drive bearing out of retainer using mallet or brass drift.
2. Remove rear seal using screwdriver or brass drift.
3. Install new bearing using Tool J-7818 (Fig. 7E-24). Be sure shielded side of bearing faces interior of case.

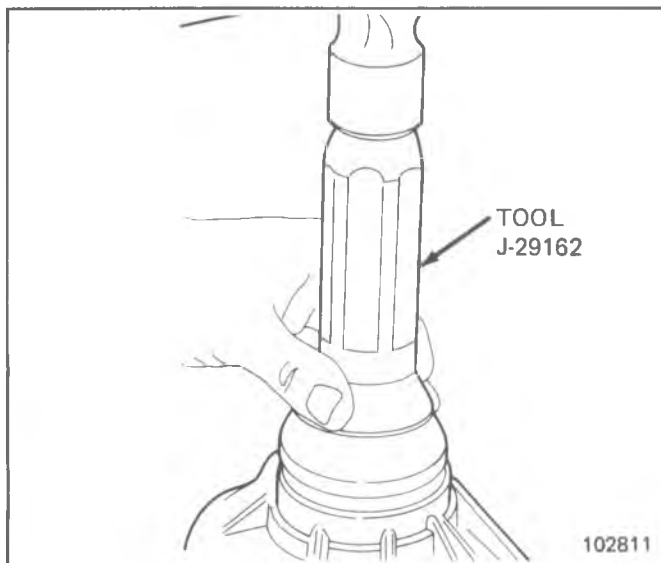

Fig. 7E-25-Rear Seal Installation

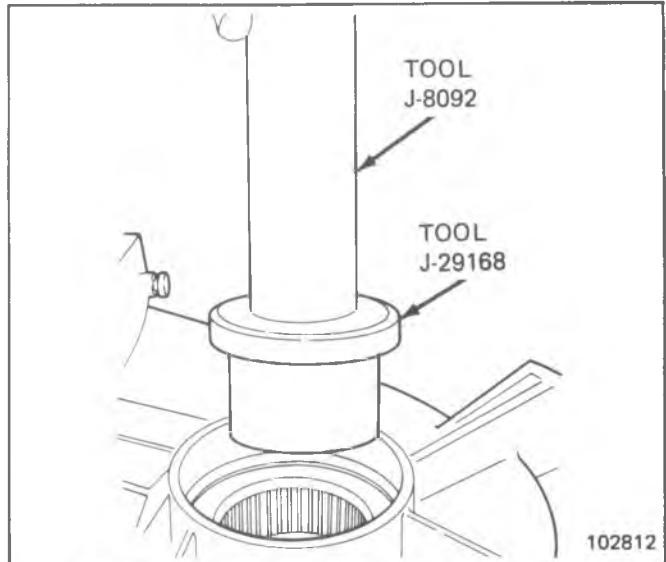

Fig. 7E-26-Front Output Shaft Front Bearing Removal

4. Install bearing retaining snap ring.
5. Install new rear seal using Tool J-29162 (Fig. 7E-25).

**Front Output Shaft/Front Bearing Replacement**

1. Remove bearing using Tools J-8092 and J-29168 (Fig. 7E-26).
2. Install new bearing using Tools J-8092 and J-29167 (Fig. 7E-27).
3. Remove installer tools and check bearing position to be sure oil feed hole is not covered.

**Front Output Shaft Rear Bearing Replacement**

1. Remove bearing using Remover J-26941 and Slide Hammer J-2619-01 (Fig. 7E-28).
2. Install new bearing using Driver Handle J-8092 and Installer J-29163 (Fig. 7E-29).
3. Remove installer tools and check bearing position to be sure oil feed hole is not covered. Also, be sure bearing is seated flush with edge of case bore to allow room for thrust bearing assembly.

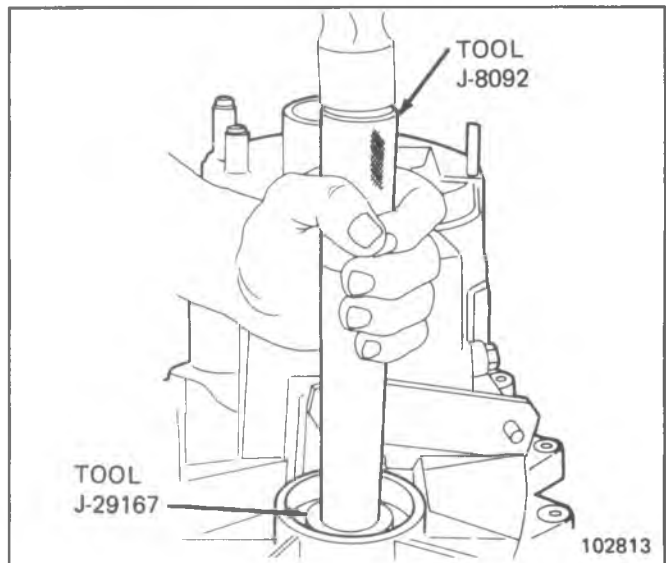

Fig. 7E-27-Front Output Shaft Front Bearing Installation

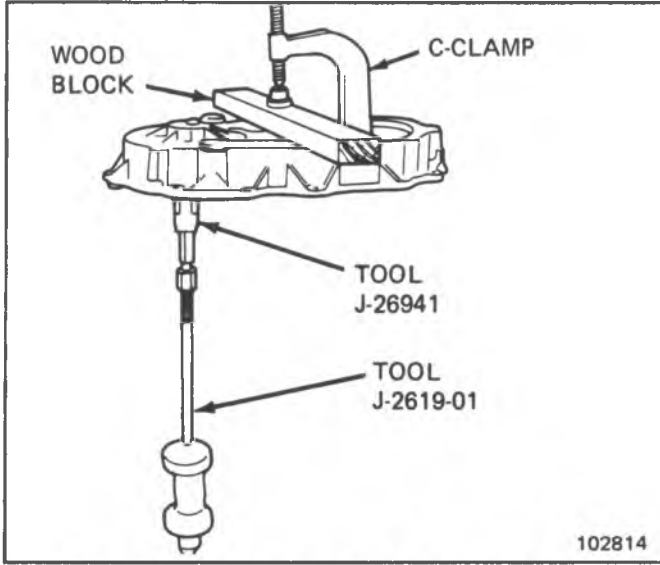

Fig. 7E-28-Front Output Shaft Rear Bearing Removal

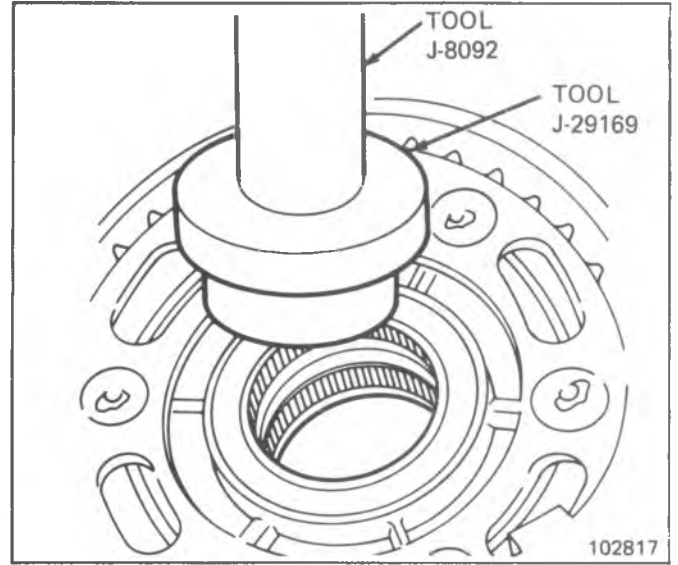

Fig. 7E-31-Input Gear Bearing Installation

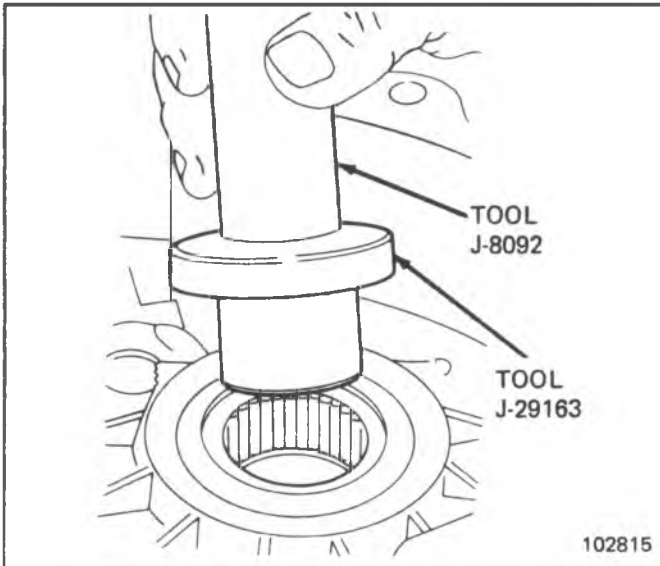

Fig. 7E-29-Front Output Shaft Rear Bearing Installation

**Input Gear Front/Rear Bearing Replacement**

1. Remove both bearings simultaneously using Driver Handle J-8092 and Remover J-29170 (Fig. 7E-30).
2. Install new bearings one at a time. Install rear bearing first; then install front bearing. Use Driver Handle J-8092 and Installer J-29169 (Fig. 7E-31).
3. Remove installer tools and check bearing position to be sure oil feed holes are not covered. Also, be sure bearings are flush with case bore surfaces.

**Mainshaft Pilot Bearing Replacement**

1. If bearing cannot be removed by hand, remove it using Slide Hammer J-2619-01 and Remover J-29369-1 or similar internal type blind hole bearing puller (Fig. 7E-32).
2. If necessary, install new bearing using Driver Handle J-8092 and Installer J-29174 (Fig. 7E-33).
3. If bearing was seated using installer tools, check bearing position to be sure oil feed hole is not covered. Also, be sure bearing is seated flush with edge of oil hole.

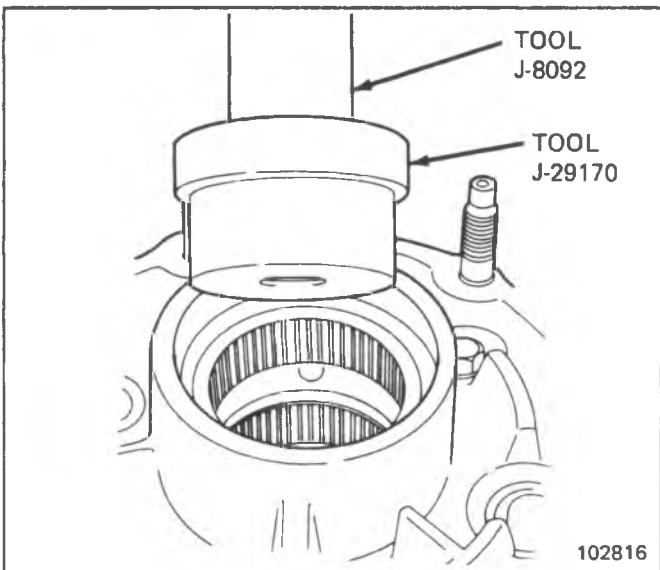

Fig. 7E-30-Input Gear Bearing Removal

**REASSEMBLY AND INSTALLATION**

During assembly, lubricate components with Dexron® II or petroleum jelly.

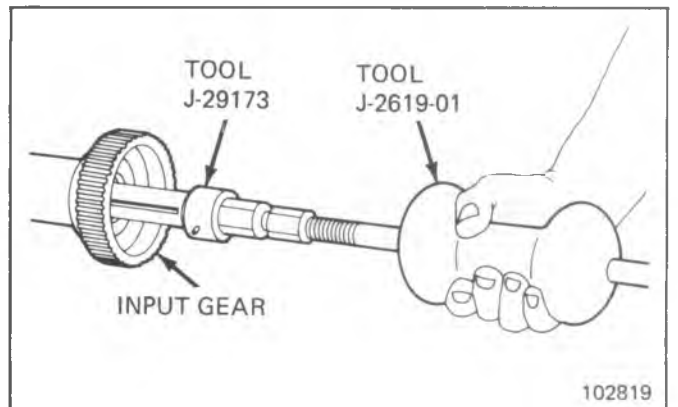
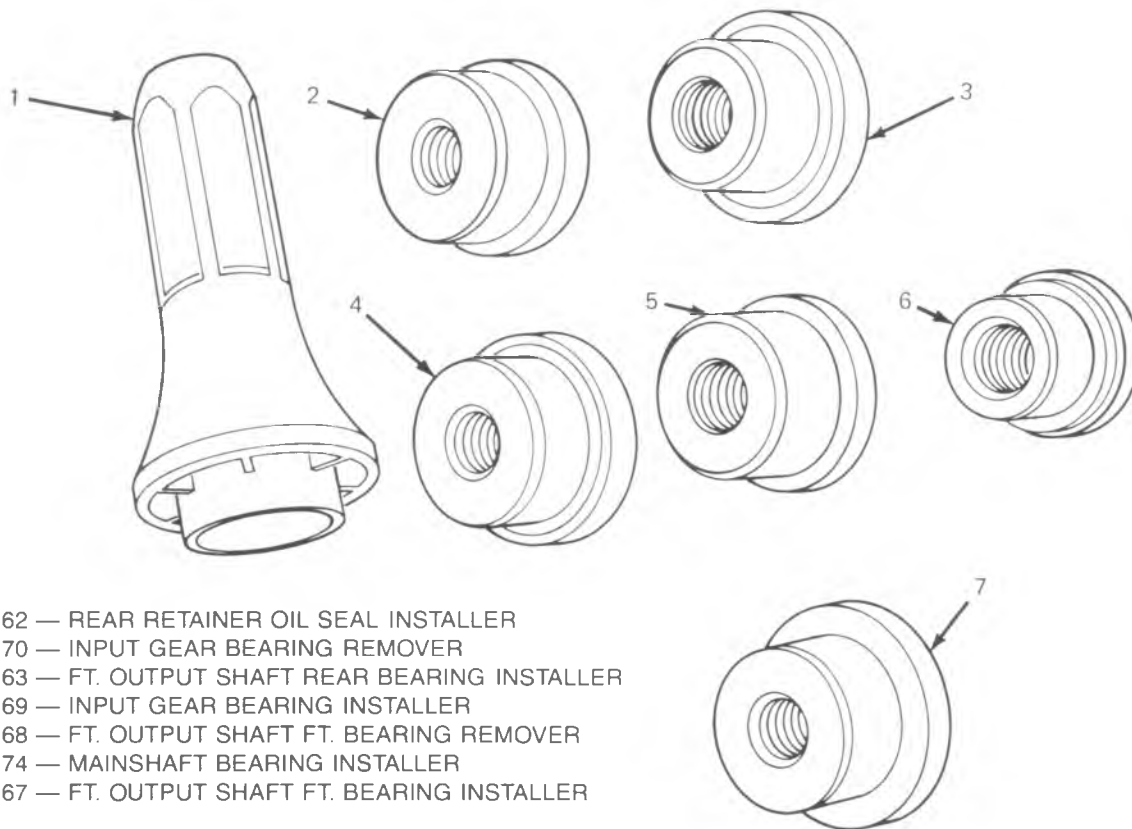

Fig. 7E-32 Mainshaft Pilot Bearing Removal



- 1. J-29162 — REAR RETAINER OIL SEAL INSTALLER
- 2. J-29170 — INPUT GEAR BEARING REMOVER
- 3. J-29163 — FT. OUTPUT SHAFT REAR BEARING INSTALLER
- 4. J-29169 — INPUT GEAR BEARING INSTALLER
- 5. J-29168 — FT. OUTPUT SHAFT FT. BEARING REMOVER
- 6. J-29174 — MAINSHAFT BEARING INSTALLER
- 7. J-29167 — FT. OUTPUT SHAFT FT. BEARING INSTALLER

103582

Fig. 7E-S11--208--Special Tools

## SECTION 8B

# CHASSIS ELECTRICAL

|  |      |  |       |
|--|------|--|-------|
| <b>General Description</b> .....   | 8B-1 | Standard Washer System.....                    | 8B-4  |
| Lights and Lighting Circuits.....  | 8B-1 | Fluidic Washer System.....                     | 8B-4  |
| Horn.....  | 8B-2 | Fuse Block.....                                | 8B-4  |
| Ignition Switch.....   | 8B-2 | Fusible Link.....                              | 8B-4  |
| <b>Neutral Start Switches</b> .....  | 8B-2 | Convenience Center.....                        | 8B-4  |
| Park/Neutral Start Switch.....   | 8B-2 | <b>Diagnosis-Lights</b> Lighting Circuits..... | 8B-5  |
| Manual Transmission-Clutch Operated Start Switch.....                        | 8B-2 | <b>On-Car Service</b> .....                    | 8B-5  |
| Automatic Transmission-Combination Neutral/Start/<br>Backup Lamp Switch..... | 8B-2 | Maintenance.....                               | 8B-5  |
| Seat Belt Warning System.....  | 8B-2 | Wiring Harness Service and Repair.....         | 8B-5  |
| Seat Belt, Key, Headlight Audio Alarm Warning.....                           | 8B-2 | Fusible Link-Replacement.....                  | 8B-11 |
| Windshield Wiper System.....   | 8B-4 | <b>Front Lighting Adjustments</b> .....        | 8B-12 |
|  |      | Light Aiming.....                              | 8B-12 |
|  |      | Lamp Replacement.....                          | 8B-12 |

For vehicles sold in Canada and equipped with non-closed loop engines,  
also refer to the appropriate Canadian Service Manual Supplement.

The following information will aid in diagnosis and switch and bulb replacement when used with the circuit information provided in Section 8B. All diagnostic information in this section assumes that all wires are connected and routed as designed. Disconnected and rerouted wires must be corrected or taken into account before any diagnosis can be performed.

### GENERAL DESCRIPTION

#### LIGHTS AND LIGHTING CIRCUITS

The headlights are controlled by a light switch located on the instrument panel. This switch also controls the parking lights, side marker lights, taillights, license plate light, instrument panel lights, and interior lights.

The parking lights, taillights, license plate light, side marker lights and instrument panel lights operate whenever the parking light switch is partially activated. The headlights turn on, in addition to lights activated by the parking light switch, when the headlight switch is fully activated. Intensity of instrument panel lights can be varied from off to bright by rotating the light switch or panel control. Rotating the control fully up past the detent will turn on passenger compartment interior lights.

A side reflex reflector is provided in the side marker lights with rear reflex installed in either combination rear lights or backup lights.

Directional signal lights are combined with the parking lights in front and with the stop and taillights in the rear. The ignition must be "ON" for the directional signal lights to be operated with the turn signal switch.

With the directional signal switches in neutral position, stepping on the brake pedal will illuminate the rear stop lights on both sides. If the switch is operating either side as a directional signal, stepping on the brake pedal will turn on the stop light only on the side which is not flashing. The flasher used in this circuit controls only the directional signals and is located on the fuse panel.

The lane-change directional signal switch is standard equipment. When making a partial turn, such as when

changing lanes, the driver has the option of moving the switch lever to a detent stop. The signal lamps will continue to flash as long as the lever is held in this position and will cancel automatically when the lever is released. By using the detent position, a shallow turn or lane change can be signaled without possibility of failure to cancel.

Moving the directional signal switch lever past the detent position to the limit of its travel for either turn will provide conventional turn signal operation. Front side marker lights, when separate from the park and turn signal lights, will flash with turn signal lights when park lights and headlights are off. When parking lights or headlights are on, the front side marker lights will flash alternately with the turn signal lights on the same side of the vehicle.

With the headlight switch in the "ON" position, the turn signal lever functions also as the headlight dimmer switch. Pulling the lever toward the driver and releasing it, switches the headlights to high or low beam.

On models with "Flash to Pass" feature, pulling the lever towards the driver will turn on the high beam headlights, as long as the lever is held in this position. This function is independent of the headlight switch operation.

A Hazard Warning flasher is included in the directional signal circuit. Pushing the switch control button (on right side of steering column) inward will disconnect the regular directional signal flasher and energize the Hazard Warning flasher regardless of ignition switch or directional signal switch position. Pulling the button collar outward will cancel the Hazard Warning flasher.

When the Hazard Warning flasher is operating, the directional signal indicator lights, and all front and rear turn signal lights will flash, as well as front side marker lights if separate from park and signal lights. If the brake pedal is depressed while the Hazard Warning flasher is operating, all signal lights will burn continuously.

The backup lights are connected to operate with the ignition "ON". This is through the neutral start switch on automatic transmission or a transmission or a transmission-mounted switch on manual transmission. Placing the vehicle shift lever in "REVERSE", cycles the switch turning the backup lights on both day or night.

Most problems in vehicle lighting can be visually diagnosed and easily corrected. Problems such as bulb burnout, cracked lens, loose or cut wires, etc., constitute the majority of problems and involve only replacement of a defective or damaged part. For more difficult problems, see Diagnosis Charts.

Where removal of a part involves special procedures (lens and housing assembly sealed together, etc.), follow special instructions normally included in replacement package. Where removal of a part involves special seal items, such as seal washers under the heads of the lens retaining screws, be sure to replace items when reinstalling. Likewise, any body sealing (grommets, etc.) disturbed by wiring repairs or replacement, should be restored during service to maintain passenger compartment sealing.

The wiring harnesses use a standardized color code common to all vehicles. Under the color code, the color of the wire designates a particular circuit. The harness title indicates the type of harness, single or multiple wire, and also describes the location of the harness. Circuit Identification Charts and wiring diagrams are shown in the rear of this manual.

## HORN

A single horn is standard on some models, while dual horns are standard on some models and optional on others.

Each horn utilizes a solenoid-actuated diaphragm to develop a resonating air column in horn projector.

A relay is used in the horn circuit because of high current required to operate horns. The relay reduces the length of heavy gage wire required and provides a more direct connection between horns and battery. Consequently, high voltage is available at the horns and better performance is obtained by eliminating voltage drop which otherwise would be in the horn button wiring circuit.

## IGNITION SWITCH

The ignition switch is located in the steering column on the right hand side just below the steering wheel. The electrical switching portion of the assembly is separate from the key and lock cylinder. However, both are synchronized and work in conjunction with each other through the action of the actuator rod assembly.

For a complete explanation of the key and lock cylinder, and the actuator rod assembly, see STEERING, Section 3B.

The ignition and starting switch is key operated through the actuator rod assembly to close the ignition primary circuit and to energize the starting motor solenoid for cranking.

The ignition switch used on all cars has five positions: Two "OFF" positions ("OFF" and "OFF-LOCKED") "ACCESSORY," "RUN" and "START", "OFF" is the center position of the key-lock cylinder and "OFF-LOCKED" is the next position to the left.

"ACCESSORY" is located one more detent to the left of "OFF-LOCKED". Turning the key to the right of the "OFF" position until spring pressure is felt will put the ignition switch in the "RUN" position, and when turned fully to the right against spring pressure, the switch will be in the "START" position.

The connections to the ignition switch are shown in the Wiring Diagrams at the end of this manual. The charts included on the diagrams show how the switches are internally connected in each switch position. Fig. 8B-1 also shows how the switch is internally connected.

## NEUTRAL START SWITCHES

### PARK/NEUTRAL-START SWITCH

The neutral start switch, used on most models, prevents the engine from being started in gear. Some models with automatic transmission use a mechanical lock-out to prevent starting, except in "Neutral" or "P".

### MANUAL TRANSMISSION-CLUTCH OPERATED START SWITCH

This system prevents starting the engine in any gear, unless the clutch is disengaged (clutch pedal depressed firmly to the floor). Installation and adjustment of switch is covered in "On-Car Service".

### AUTOMATIC TRANSMISSION COMBINATION NEUTRAL/START/BACKUP LAMP SWITCH

This system, used with automatic transmission, combines the neutral start and backup lamp switches in a single switch mounted on transmission shift mechanism on the steering column. Adjustment of the switch is covered in "On-Car Service".

### SEAT BELT WARNING SYSTEM

The seat belt warning system is the "8-SECOND-ON" system.

This system will activate a warning lamp and buzzer for approximately 8 seconds when the ignition key is turned to the "ON" position if the driver's seat belt is not buckled. Rapid cycling of the system will result in a decrease in the time period. The warning lamp and buzzer with timer sequence of operation is as follows:

1. "DRIVER'S BELT UNFASTENED" Turn ignition switch "ON" - warning lamp and buzzer both come on for approximately 8 seconds, then go off and stay off. If belt buckle is fastened prior to 8 second turn-off time, buzzer will go off and warning lamp stays on for balance of 8 second delay time.
2. "DRIVER'S BELT FASTENED" Turn ignition switch "ON" - warning lamp comes on; buzzer does not. At end of approximately 8 seconds, warning lamp goes off and stays off. If buckle is unfastened prior to 8 second turn-off time, buzzer and warning lamp both stay on for balance of 8 second delay time. Warning lamp always comes on for full 8 second time, while the buzzer is controlled by the driver's seat belt buckle switch or seat belt retractor switch. Warning lamp is controlled only by ignition switch and timer.

### SEAT BELT, KEY, HEADLIGHT AUDIO ALARM WARNING

Some models use an audio alarm system to remind the driver to fasten seat belts, remove ignition key, and to turn off the headlights.

This system uses a tone generator which will sound approximately three to five times and activate a warning light on the instrument panel when the ignition key is

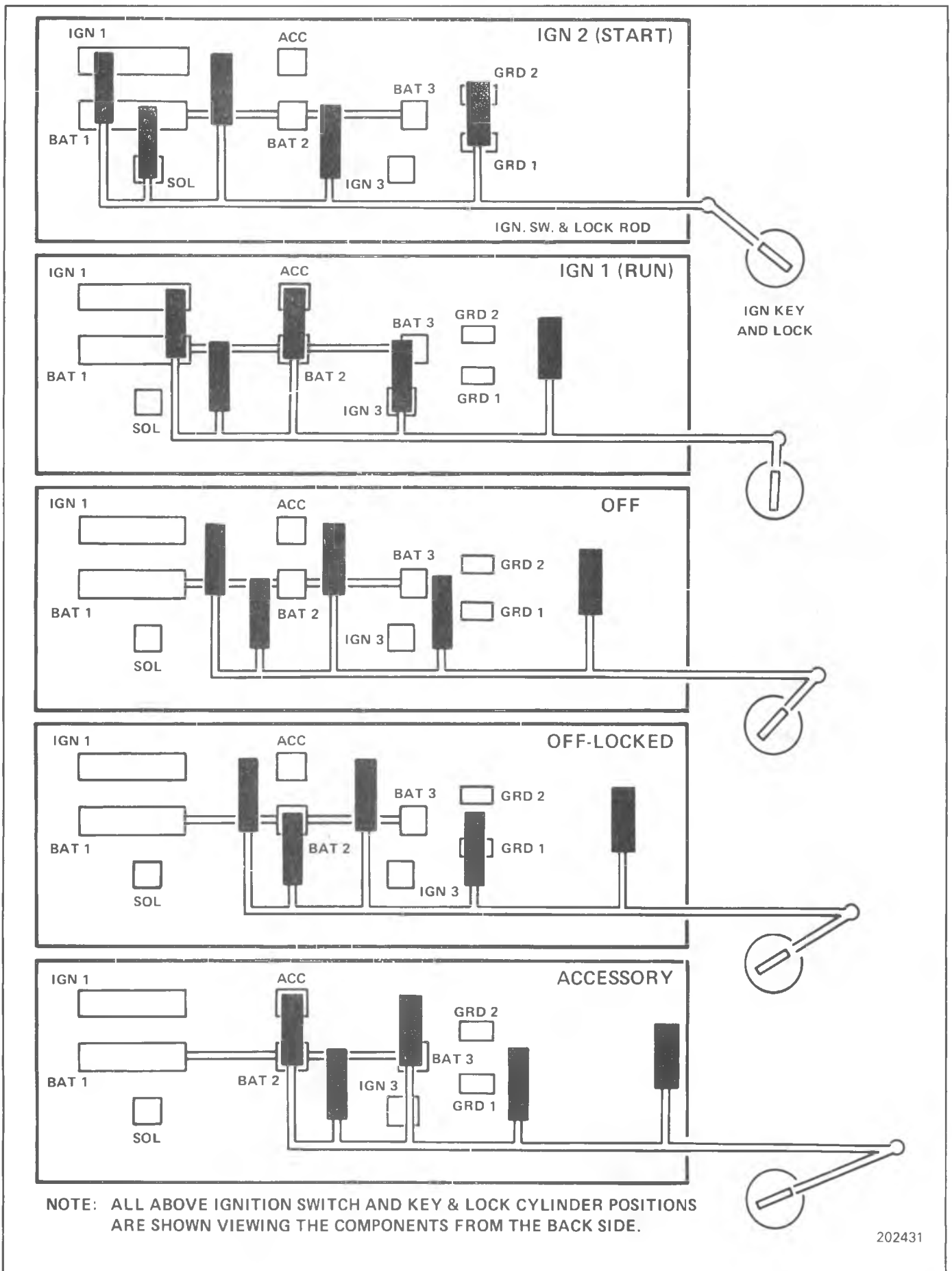

Fig. 8B-1--Ignition Switch Operation

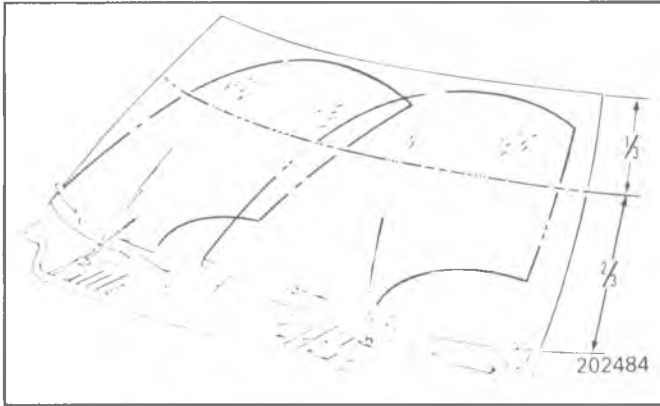

Fig. 8B-2--Windshield Washer Target Area

turned to the "ON" position if the driver's seat belt is not buckled. If the ignition key is turned to the "OFF" position and the headlights are on, the tone generator will sound (chime) to remind the driver that the headlights are on. If, however, the I.P. light dimmer thumbwheel is turned to the full "OFF" position and the headlights are "ON", the tone generator will not sound when the key is turned to the "OFF" position. If the driver's door is opened and the key is left in the ignition, the tone generator will also sound. The tone generator location is shown in "On-Vehicle Service".

## WINDSHIELD WIPER AND WASHER SYSTEM

### Windshield Wiper System

The windshield wiper motor and all connection linkage are covered in the Body Service Manual.

Electrical diagnosis of the windshield wiper system is covered in Section 8C.

Controlled cycle wiper systems are covered in the Accessory Section.

### Standard Washer System

The washer system is a pulse system which operates for a pre-determined number of pulses when the washer button is depressed or a continuous-run system that provides fluid as long as the washer button is depressed.

Refer to Sections 3B and 9 for replacement of multi-function switch mounted in steering column.

Any time washer nozzles must be replaced, insure that the spray pattern falls within the area shown in Figures 8B-2 and 8B-3.

### Fluidic Washer System

Some models use a fluidic windshield washer system. The system consists of a fluid container, pump, wiper motor, fluidic hoses and pipes, nozzle mounts, nozzle(s) and wiper arms.

The fluidic washer system is controlled by a small plastic element designed into the washer nozzle. As water is forced through this insert, the design of the mechanism creates an oscillating power stream. This fluidic washer system produces larger, more widely dispersed droplets, resulting in a more efficient cleaning action than with conventional spray nozzles.

A correctly operating system should deliver a spray pattern just below the lower edge of the windshield upper reveal molding. The bottom edge of the spray pattern should fall on a line about 254mm (10") below the upper edge of the windshield (Fig. 8B-2).

Spray pattern level can be adjusted by shimming as shown in "On-Vehicle Service".

If the nozzles become plugged, they can be serviced only by replacement Pump and wiper motor service remain unchanged.

## FUSE BLOCK

The fuse block on some models is a swing-down unit located in the underside of the instrument panel adjacent to the steering column. Access to the fuse block on some models is gained through the glove box opening. All models use a fuse block for miniaturized fuses, designed for increased circuit protection and greater reliability. Various convenience connectors, which snap-lock onto the fuse block, add to the serviceability of this unit.

A miniaturized fuse is used with the fuse block. This compact fuse, with blade terminal design, allows finger tip removal and replacement. Fuses of different ratings are physically interchangeable, but amperage values are molded in bold, color coded, easy-to-read numbers on the fuse body. Be sure that only fuses of proper ratings are used for replacement. Replacing a fuse with one of a higher than recommended value is not recommended.

A suspected blown fuse can easily be pulled out and examined. The clear plastic body gives full view of the element to blade construction for visual checking for defects. In addition, blade terminal tips are exposed in the fuse body, allowing for continuity checking if desired.

## FUSIBLE LINK

Added protection is provided in all battery feed circuits and other selected circuits by a fusible link. This link is a short piece of copper wire approximately 4" long inserted in series with the circuit and acts as a fuse. The link is four (4) or more gages smaller in size than the circuit wire it is protecting and will burn out without damage to the circuit in case of current overload. The chassis electrical wiring diagrams at the end of the manual show the locations and colors of these fusible links.

## CONVENIENCE CENTER

The Convenience Center on some models is a swing-down unit located on the underside of the instrument panel. The swing-down feature provides central location and easy access

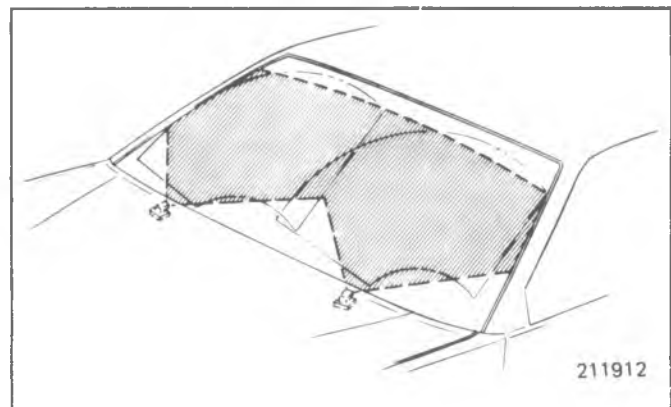

Fig. 8B-3--Windshield Washer Target Area-Fluidic Nozzles

to buzzers, relays and flasher units. All units are serviced by plug-in replacement. Location of Convenience Center on specific models is covered in Section 8C.

### DIAGNOSIS-LIGHTS AND LIGHTING CIRCUITS

Troubles in the lighting circuits are caused by loose connections, open or shorted wiring, burned out bulbs, failed switches, inadequate ground or blown fuses. In each, trouble diagnosis requires following through the circuits until the source of difficulty is found. To aid in making an orderly check, refer to the wiring diagrams shown in Section 8C.

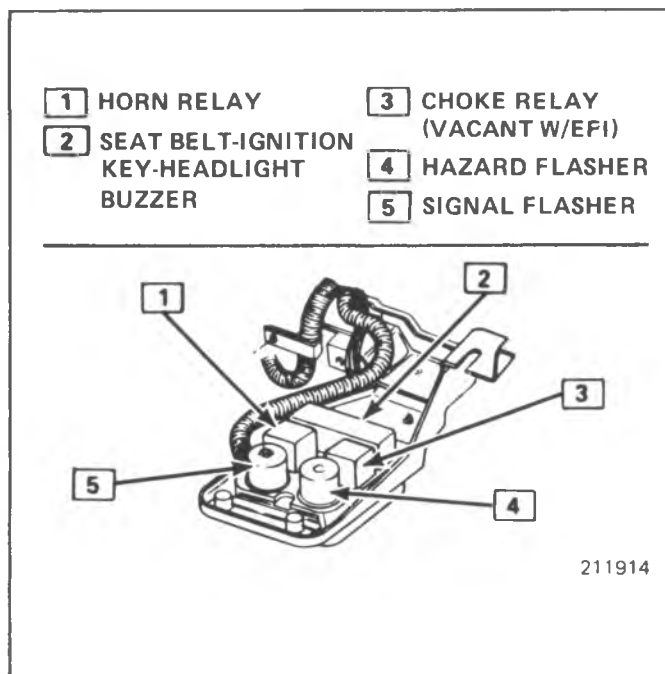

Fig. 8B-5--Convenience Center and Components - Typical

### ON-VEHICLE SERVICE

#### MAINTENANCE

Maintenance of the lighting units and wiring system consists of an occasional check to see that all wiring connections are tight and clean, that the lighting units are tightly mounted to provide good ground and that the headlights are properly adjusted. Loose or corroded connections may cause a discharged battery, difficult starting, dim lights, and possible damage to generator and charging circuit. Wire harnesses must be replaced if insulation becomes deteriorated. Whenever it is necessary to splice a wire or repair one that is broken, always use rosin core solder to bond the splice. Use insulating tape to cover all splices or bare wires.

When replacing wires, it is important that the correct gage size be used. Never replace a wire with one of a smaller gage size.

Each harness and wire must be held securely in place by clips or other holding devices to prevent chafing or wearing of the insulation due to vibration.

By referring to the wiring diagrams, circuits may be tested for continuous circuit or shorts with a conventional test light or low reading voltmeter.

#### WIRING HARNESS SERVICE AND REPAIR

Special connectors known as Weather-Pack connectors (Fig. 8B-6) require a special tool (J-28742) for servicing. This special tool is required to remove the pin and sleeve terminals. If removal is attempted with an ordinary pick, there is a good chance that the terminal will be bent or deformed. Unlike standard blade-type terminals, these terminals cannot be straightened once they are bent.

Make sure that the connectors are properly seated and all of the sealing rings in place when connecting leads. The hinge-type flap provides a backup, or secondary locking feature for the terminals. They are used to improve the connector reliability by retaining the terminals if the

### HEADLIGHT DIAGNOSIS

| Condition                                 | Possible Cause   | correction   |
|---|--|--|
| One headlight inoperative or intermittent | 1. Loose connection  | 1. Secure connections to sealed beam including ground (black wire)   |
|   | 2. Defective sealed beam unit.   | 2. Replace sealed beam.  |
| One or more headlights are dim.           | 1. Open ground connection at headlight.  | 1. Repair black wire connection between sealed beam and body ground. |
|   | 2. Black ground wire mislocated in headlight connector (three-wire, hi-lo, connector only) | 2. Relocate black wire in connector.                                 |
| One or more headlights                    | 1. Charge circuit  | 1. Refer to Section 6D,  |



| short life  | problem.  | charging system diagnosis.   |
|---|---|--|
| All headlights inoperative or intermittent          | <ol style="list-style-type: none"> <li>1. Loose connection.</li> <li>2. Defective dimmer switch.</li> <li>3. Open wiring - light switch to dimmer switch.</li> <li>4. Open wiring - light switch to battery.</li> <li>5. Shorted ground circuit.</li> <li>6. Defective light switch.</li> </ol> | <ol style="list-style-type: none"> <li>1. Check and secure connections at dimmer switch and light switch.</li> <li>2. Check voltage at dimmer switch with test light. Refer to Section 8A for test points.</li> <li>3. Check yellow wire with test light. If bulb lights at light switch yellow wire terminal but not at dimmer switch, repair open wire.</li> <li>4. Check red wire terminal at light switch with test light. If bulb does not light, repair open red wire circuit to battery (possible open fusible link).</li> <li>5. If, after a few minutes operation, headlights flicker "ON" and "OFF" and or a thumping noise can be heard from the light switch (circuit breaker opening and closing), repair short to ground in circuit between light switch and headlights. After repairing short, check for headlight flickering after one minute operation. If flickering occurs, the circuit breaker has been damaged and light switch must be replaced.</li> <li>6. Check red and yellow wire terminals at light switch with test light. If bulb lights at red wire terminal but not at yellow terminal, replace light switch.</li> </ol> |
| Upper or lower beam will not light or intermittent. | <ol style="list-style-type: none"> <li>1. Open connection or defective dimmer switch.</li> </ol>  | <ol style="list-style-type: none"> <li>1. Check dimmer switch terminals with test light. If bulb lights at light green or tan wire terminals, repair open wiring between dimmer switch and headlights. If bulb will not light at either of these terminals, depending upon switch position, replace dimmer switch.</li> </ol>  |

2. Short circuit to ground.

2. Follow diagnosis above (all headlights inoperative or intermittent)

## SIDE MARKER LIGHT DIAGNOSIS

| Condition                         | Possible Cause  | Correction  |
|-----------------------------------|---|---|
| One light inoperative             | <ol style="list-style-type: none"> <li>1. Turn signal bulb burnt out (front light)</li> <li>2. Side marker bulb burnt out.</li> <li>3. Loose connection or open in wiring.</li> </ol> | <ol style="list-style-type: none"> <li>1. Switch turn signals on. If signal bulb does not light, replace bulb. (Bulb filament provides ground path for marker lamp bulb through the dark blue or brown wires.)</li> <li>2. Replace bulb.</li> <li>3. Using test light, check brown wire terminal at bulb socket. If test bulb lights, repair open ground circuit. If bulb does not light, repair open in brown wire circuit.</li> </ol>   |
| Front or rear lights inoperative. | <ol style="list-style-type: none"> <li>1. Loose connection or open ground circuit.</li> <li>2. Multiple bulbs burnt out.</li> </ol>   | <ol style="list-style-type: none"> <li>1. If associated tail or park lights do not operate, check all connectors in brown wire circuit. If park and turn lights inoperative, repair open ground connections.</li> <li>2. Replace burnt out bulbs.</li> </ol>  |
| All lights inoperative            | <ol style="list-style-type: none"> <li>1. Blown fuse</li> <li>2. Loose connection</li> <li>3. Open in wiring</li> <li>4. Defective light switch</li> </ol>                            | <ol style="list-style-type: none"> <li>1. If park and taillights do not operate, replace blown fuse. If new fuse blows, check for short to ground between fuse panel and lights.</li> <li>2. Secure connector to light switch.</li> <li>3. Check taillight fuse with test light. If test bulb lights, repair open wiring between fuse and light switch. If not, repair open wiring between fuse and battery. (Possible open fusible link.)</li> <li>4. Check light switch with test light. If test bulb lights at orange wire but not at brown wire, replace light switch.</li> </ol> |

## TAIL, PARK AND LICENSE LIGHT DIAGNOSIS

| Condition              | Possible Cause   | Correction  |
|------------------------|--|---|
| One side inoperative   | <ol style="list-style-type: none"> <li>1. Bulb burnt out</li> <li>2. Open connection at bulb socket or ground wire terminal</li> </ol>   | <ol style="list-style-type: none"> <li>1. Replace bulb.</li> <li>2. Jumper bulb base socket connection to ground. If bulb lights, repair open ground circuit.</li> </ol>  |
| Both sides inoperative | <ol style="list-style-type: none"> <li>1. Tail light fuse blown</li> <li>2. Loose connection</li> <li>3. Open wiring</li> <li>4. Multiple bulb burnout</li> <li>5. Defective light switch</li> </ol> | <ol style="list-style-type: none"> <li>1. Replace fuse. If new fuse blows, repair short to ground in brown wire circuit between fuse panel through light switch to lights.</li> <li>2. Secure connector at light switch.</li> <li>3. Using test light, check circuit on both sides of fuse. If test bulb does not light on either side, repair open circuit between fuse panel and battery (possible open fusible link). If test bulb lights at light switch brown wire terminal, repair open wiring between light switch and lamps.</li> <li>4. If test bulb lights at lamp socket brown wire terminal, replace bulb(s).</li> <li>5. If test bulb lights at light switch orange wire but not at brown wire, replace defective light switch.</li> </ol> |

## TURN SIGNAL AND HAZARD WARNING LIGHT(S)

| Condition                         | Possible Cause   | Correction   |
|-----------------------------------|--|--|
| Turn signals inoperative one side | <ol style="list-style-type: none"> <li>1. Bulb(s) burnt out (flasher cannot be heard)</li> <li>2. Open wiring or ground connector</li> </ol> | <ol style="list-style-type: none"> <li>1. Turn hazard warning system "ON." If one or more bulbs are inoperative, replace bulbs as necessary.</li> <li>2. Turn hazard warning system on. If one or more bulbs are inoperative, use test light and check circuit at bulb socket. If test bulb lights, repair open ground connection. If not, repair open wiring between bulb socket and turn signal switch.</li> </ol> |

|                            |  |   |
|----------------------------|--|---|
|                            | <ol style="list-style-type: none"> <li>3. Improper bulb or defective turn signal switch.</li> <li>4. Short to ground. (Flasher can be heard, no bulbs operate)</li> </ol>  | <ol style="list-style-type: none"> <li>3. Turn hazard warning system on. If all front and rear lights operate, check for improper bulb (see bulb chart). If bulbs are OK, replace defective turn signal switch.</li> <li>4. Locate and repair short to ground by disconnecting front and rear circuits separately.</li> </ol>   |
| Turn signals inoperative   | <ol style="list-style-type: none"> <li>1. Blown turn signal fuse</li> <li>2. Defective flasher (located in convenience center near steering column)</li> <li>3. Loose connection</li> </ol>                            | <ol style="list-style-type: none"> <li>1. Turn hazard warning system on. If all lights operate, replace blown fuse. If new fuse blows, repair short to ground between fuse and lamps.</li> <li>2. If turn signal fuse is OK and hazard warning system will operate lights, replace defective turn signal flasher.</li> <li>3. Secure steering column connector.</li> </ol>  |
| Hazard Warning Inoperative | <ol style="list-style-type: none"> <li>1. Blown stop-hazard fuse</li> <li>2. Defective hazard warning flasher. (Located in convenience center).</li> <li>3. Open in wiring or defective turn signal switch.</li> </ol> | <ol style="list-style-type: none"> <li>1. Switch turn signals "ON." If lights operate, replace stop-hazard fuse if blown. If new fuse blows, repair short to ground. (Could be in stop light circuit.)</li> <li>2. If stop-hazard fuse is OK, switch turn signals on. If lights operate, replace defective hazard flasher.</li> <li>3. Using test light, check brown wire in turn signal steering column connector. If test bulb does not light, repair open circuit between flasher and connector. If test light indicates power on brown wire and connection is good, use test light to check output terminals (lt. blue, blue, yellow and dark green wires) see Section 8A.</li> </ol> |

## BACKUP LIGHT

| Condition                                | Possible Cause  | Correction   |
|--|---|--|
| One light inoperative or intermittent    | <ol style="list-style-type: none"> <li>1. Loose or burnt out bulb.</li> <li>2. Loose connection</li> <li>3. Open ground connections.</li> </ol>   | <ol style="list-style-type: none"> <li>1. Secure or replace bulb.</li> <li>2. Tighten connectors.</li> <li>3. Repair bulb ground circuit.</li> </ol>   |
| Both lights inoperative or intermittent. | <ol style="list-style-type: none"> <li>1. Gear selector switch misadjusted (open when shifter lever is in reverse position)</li> <li>2. Loose connection or open circuit</li> <li>3. Blown fuse</li> <li>4. Defective gear selector or backup light switch</li> <li>5. Defective ignition switch</li> </ol> | <ol style="list-style-type: none"> <li>1. Readjust gear selector switch.</li> <li>2. Check all connectors. If OK, check continuity of circuit from fuse to light on either side of fuse, correct open circuit from battery to fuse.</li> <li>3. Replace fuse. If new fuse blows, repair short to ground in circuit from fuse through gear selector or from fuse through gear selector or backup light switch to backup lights.</li> <li>4. With ignition "ON," check switch terminals in backup position with test light. If test bulb lights at dark blue wire terminal but not at light green wire terminal, replace light switch.</li> <li>5. If test bulb lights at ignition switch battery terminal but not as output terminal, replace ignition switch.</li> </ol> |
| Light will not turn off                  | <ol style="list-style-type: none"> <li>1. Gear selector switch misadjusted (closed when shift lever is not in reverse position)</li> </ol>  | <ol style="list-style-type: none"> <li>1. Readjust gear selector switch.</li> </ol>  |

## STOP LIGHTS

| Condition                                | Possible Cause   | Correction   |
|--|--|--|
| One bulb inoperative                     | <ol style="list-style-type: none"> <li>1. Bulb burnt out.</li> </ol>                                   | <ol style="list-style-type: none"> <li>1. Replace bulb.</li> </ol>   |
| One side inoperative (multi-bulb design) | <ol style="list-style-type: none"> <li>1. Loose connection, open wiring or defective bulbs.</li> </ol> | <ol style="list-style-type: none"> <li>1. Turn on directional signal. If light does not operate, check bulbs. If bulbs are OK, check all connections.</li> </ol> |

|                             |   |  |
|-----------------------------|---|--|
|                             | 2. Defective directional signal switch or cancelling cam  | If light still does not operate, use test light and check for open wiring.<br>2. If light will operate by turning directional signal on, the switch is not centering properly during cancelling operation. Replace defective cancelling cam or directional signal switch.  |
| All stop lights inoperative | 1. Stop-hazard fuse blown<br><br>2. Open in wire from fuse to stop-switch<br><br>3. Stop-switch mis-adjusted or defective | 1. Replace fuse. If new fuse blows, repair short to ground in circuit between fuse and lights.<br>2. Check for power at brown wire at stop-switch and at fuse. If there is power at fuse but not at switch, check for open in brown wire.<br>3. With brake pedal depressed, check white wire terminal in steering column connector with test light. If bulb does not light, check stop switch for proper adjustment. If adjustment is OK, jumper stop switch. If stop lights operate, replace stop switch. |
| Will not turn off           | 1. Stop switch misadjusted or defective   | 1. Readjust switch. If switch still malfunctions, replace.   |

small terminal lock tangs are not positioned properly.

Molded-on-connectors require complete replacement of the connection. This means splicing a new connector assembly into the harness. Environmental connections cannot be replaced with standard connections.. Instructions are provided with Weather-Pack connector and terminal packages.

With the low current and voltage levels found in some circuits, it is important that the best possible bond at all wire splices be made by soldering the splices as shown in Fig. 8B-7.

Use care when probing the connections or replacing terminals in them, it is possible to short between opposite terminals. If this happens to the wrong terminal pair, it is possible that damage may be done to certain components.

Always use jumper wires between connectors for circuit checking. Never probe through the Weather-Pack seals.

When diagnosing for possible open circuits, it is often difficult to locate them by sight because oxidation or terminal misalignment are hidden by the connectors. Merely wiggling a connector on a sensor or in the wiring harness may correct the open circuit condition. This should always be considered when an open circuit is indicated while troubleshooting. Intermittent problems may also be caused by oxidized or loose connections.

**FUSIBLE LINK-REPLACEMENT**

**Remove and Replace**

1. Disconnect battery.
2. Located burned out link. This may require use of the chassis wiring diagrams.

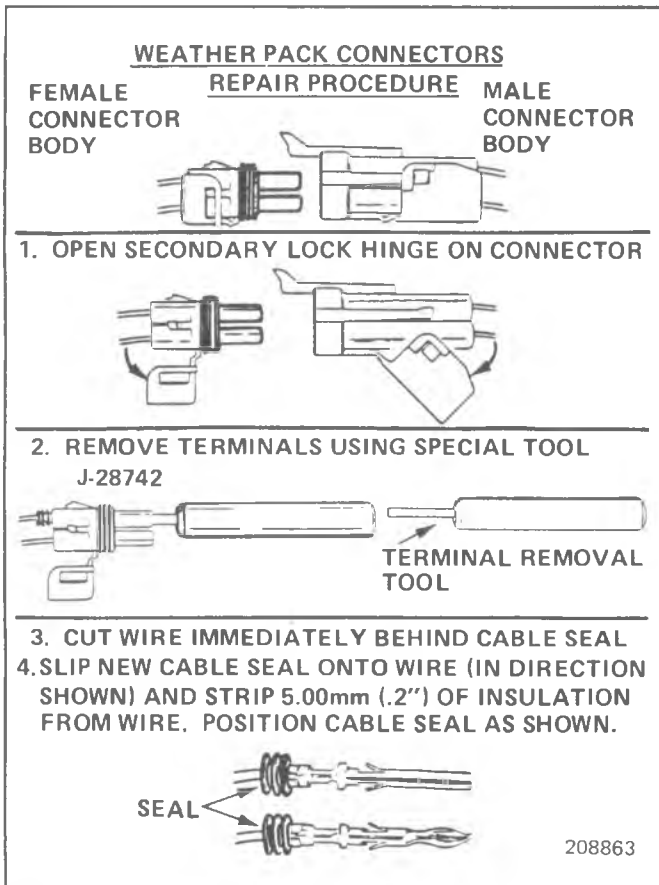

Fig. 8B-6--Weather-Pack Terminals

3. Strip away all melted harness insulation.
4. Cut burned link ends from circuit wire.
5. Strip circuit wire back approximately 1/2" to allow soldering of new link.
6. Using fusible link four(4) gages smaller than protected circuit (approximately 10" long), solder new link into circuit.

**NOTICE:** Use only resin core solder. Under no circumstances should an acid solder be used nor should link be connected in any other manner except by soldering. Use of acid core solder may result in corrosion.

7. Tape soldered ends securely using suitable electrical tape.
8. After taping wire, tape harness leaving an exposed loop of wire approximately 5" in length.
9. Reconnect battery.

## FRONT LIGHTING ADJUSTMENTS

### LIGHT AIMING

The front lights (headlights, fog lights, driving lights, etc.) must be properly aimed in order to provide maximum allowable road illumination. When using mechanical aimers, follow equipment manufacturers instructions.

Front lights should be checked for proper aim at new car predelivery, every 12 months, after installing a new sealed beam unit or if front end sheet metal is adjusted or

repaired. Replacement of a bulb in a nonsealed beam unit will normally not require unit aiming readjustment. Aiming of headlights can be performed without removing headlight bezels (Figure 8B-8).

Horizontal and vertical aiming of each headlight sealed beam unit is provided by two (2) adjusting screws which move the mounting ring in the body against the tension of the coil spring. There is no adjustment for focus since the sealed beam unit is set for proper focus during manufacturing assembly.

Some state and local authorities have specific requirements for front light aiming adjustments and these requirements should be followed.

## ON-VEHICLE SERVICE

### SEALED BEAM UNIT

#### Replacement (Figs. 8B-9 and 8B-10)

1. Remove bezel retaining screws and bezel.
2. Remove retaining ring.  
Do not disturb adjusting screw setting.
3. Disconnect wiring harness connector located at rear of unit in engine compartment and remove sealed beam unit.
4. Attach wiring harness connector to unit.
5. Position new sealed beam unit in mounting ring and install retaining ring.  
The number molded into lens face must be at top.
6. Install retaining ring then check operation of unit and install bezel.

### PARKING LAMP BULB

#### Replacement (Figs. 8B-9 and 8B-10)

1. Remove lens retaining screws and remove lens from the housing.
2. Replace bulb and check lamp operation.
3. Install lens and retaining screws.

### PARKING LAMP HOUSING

#### C-K Models

##### Replacement (Fig. 8B-9)

1. Remove parking lamp lens screws and remove the lens.
2. Remove lamp housing retaining screws and pull housing forward.
3. Disconnect parking lamp wiring harness from housing by rotating bulb socket counterclockwise.
4. Connect wiring harness to new housing by inserting bulb socket into housing and rotating clockwise.
5. Install bulb if removed during disassembly. Install lens and retaining screws.

#### G Models

##### Replacement (Fig. 8B-10)

##### Right Side

1. Remove both headlamp bezels.
2. Remove both parking lamp lens.
3. Remove grille.
4. Remove battery and battery box.

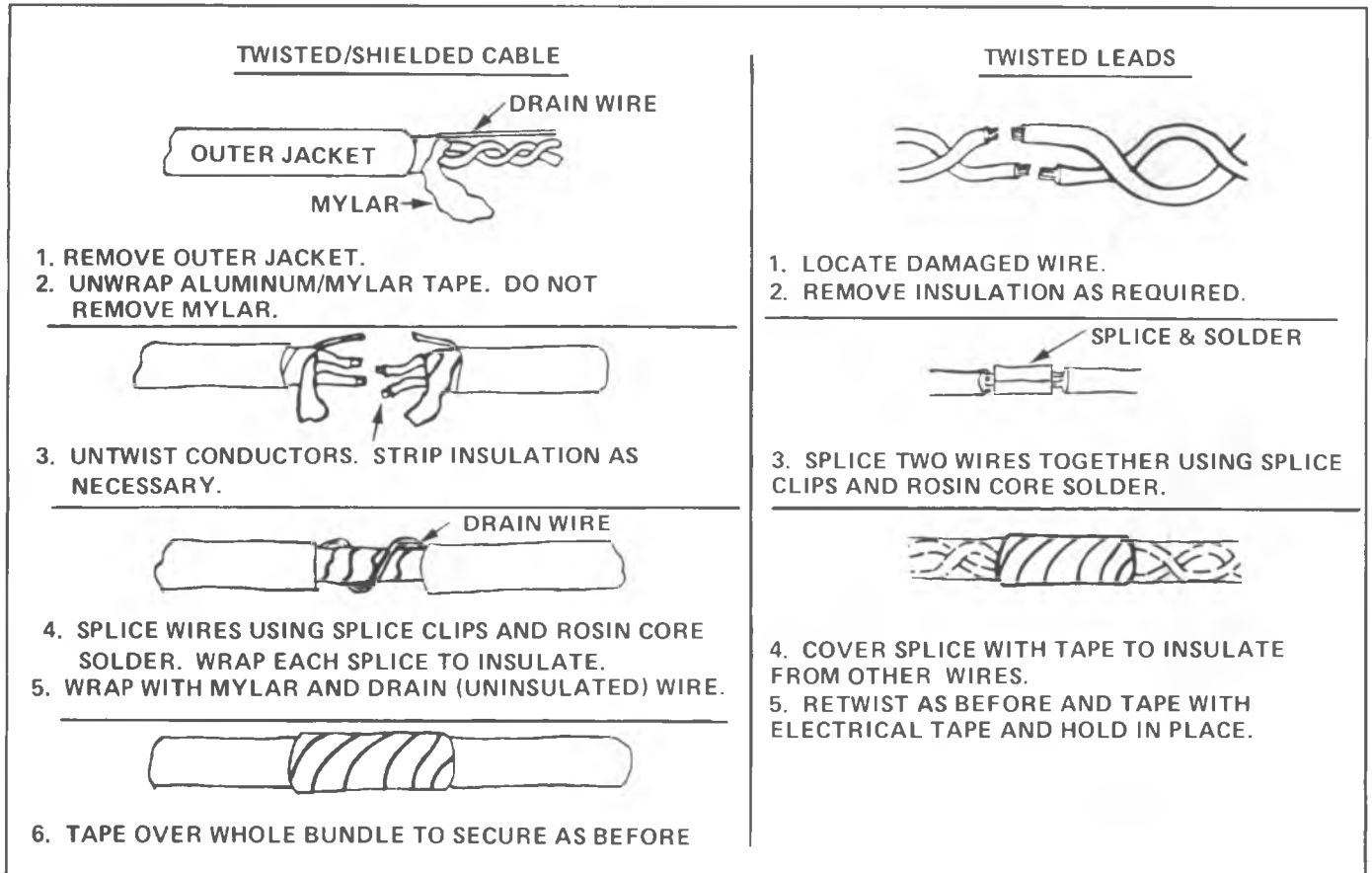

Fig. 8B-7--Wiring Repair

5. Disconnect wiring harness at connector.
6. Remove housing stud nuts and remove housing with pigtail.
7. To install, reverse removal steps.

**Left Side**

1. Remove two screws and parking lamp lens.
2. Disconnect wiring harness at connector.
3. Remove housing stud nuts and remove housing with pigtail.

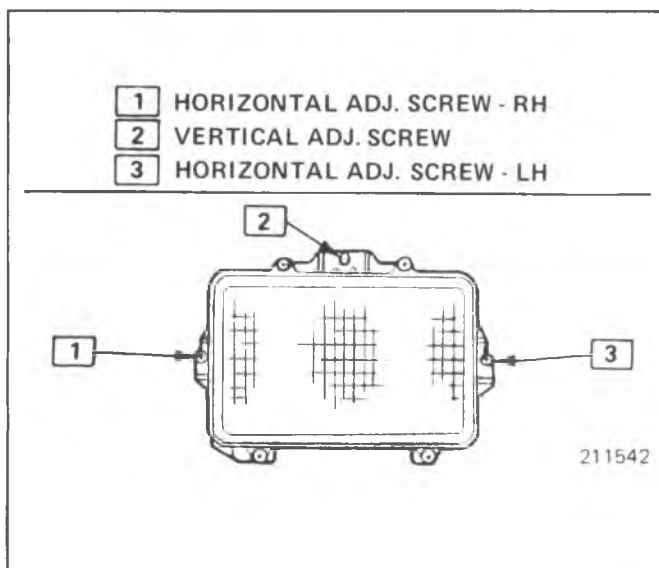

Fig. 8B-8--Headlight Aiming Screws

4. To install, reverse removal steps.

**FRONT SIDE MARKER LAMP BULB AND/OR HOUSING**

**All Models**

**Replacement**

For housing replacement follow procedure for the right side bulb replacement below.

1. **Left Side** - Raise hood.  
**Right Side** - Remove lamp assembly retaining screws and pull outward on assembly.
2. Twist wiring harness socket 90° counterclockwise and remove harness and bulb from housing.
3. Replace bulb and check lamp operation.
4. Insert bulb into housing, press in on harness socket and twist 90° clockwise. Check that socket is securely attached.
5. **Left Side** - Lower hood.  
**Right Side** - Install housing in opening and install retaining screws.



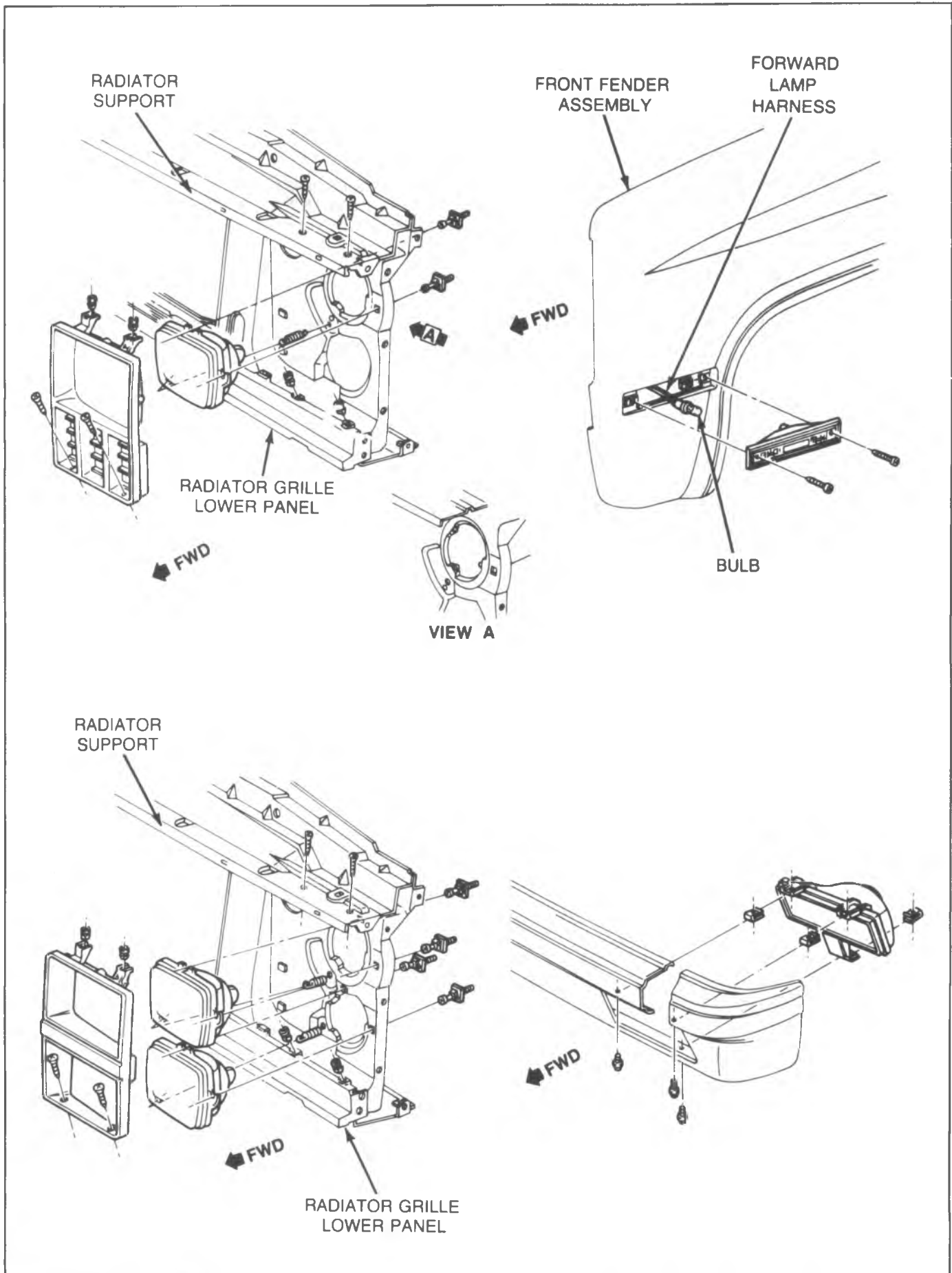

Fig. 8B-9-Front Lighting (C-K Models)

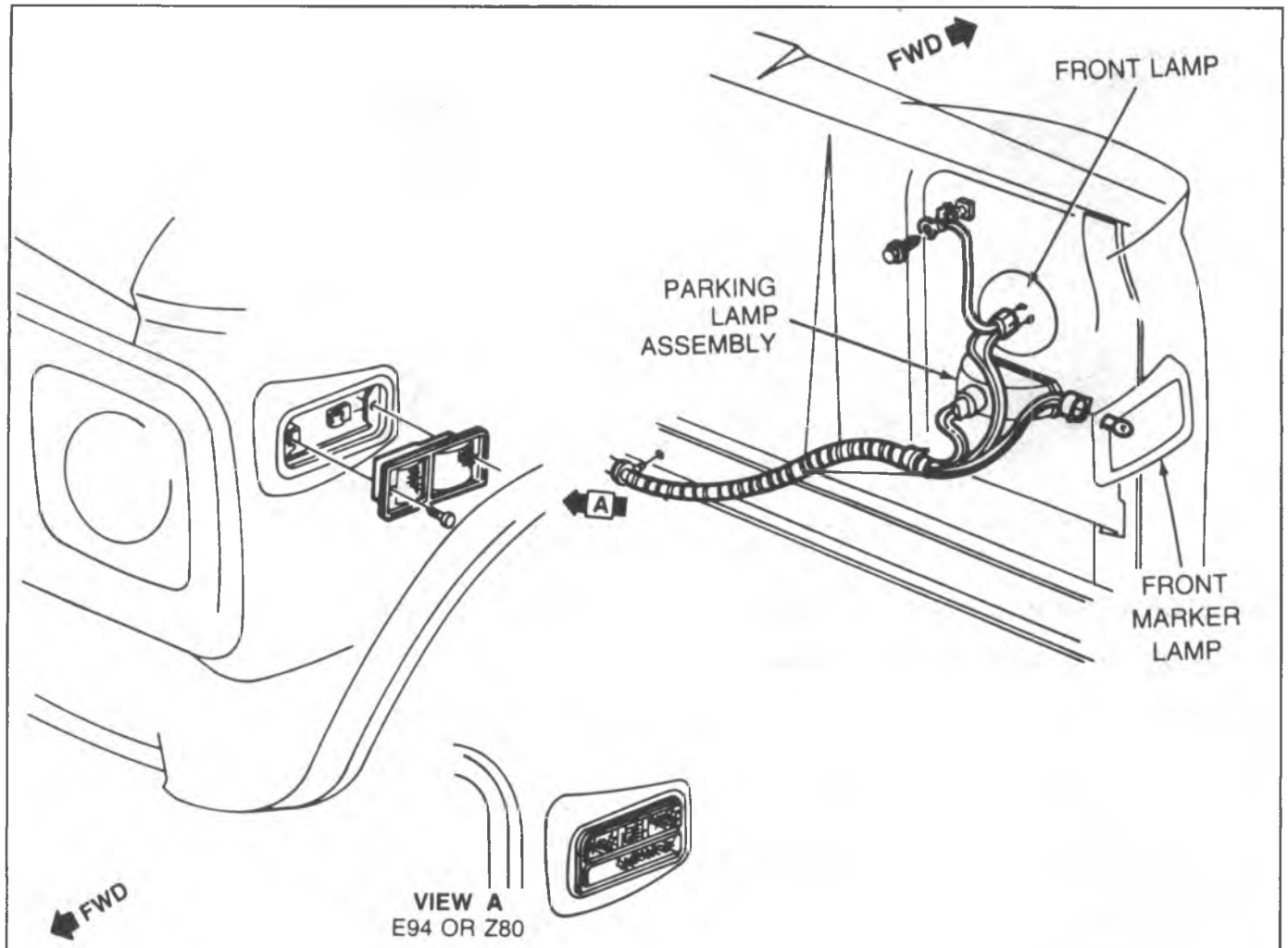

Fig. 8B-10--Front Lighting (G Models)

### REAR SIDE MARKER LAMP BULB AND/OR HOUSING

#### C-K 03 models with E62 and G Models

##### Replacement

Same as Right Front Side Marker Lamp Bulb and/or Housing Replacement - All Vehicles. Bulb on G Models without interior trim may be removed from inside the vehicle.

#### C-K 16, 03 and 63 with E63, and 06 Models

##### Replacement

1. Remove lens to housing four screws.
2. Replace bulb and check operation.
3. Position lens and install four attaching screws.

#### Platform and Stake Rack Models (E56)

Exploded view of the different rear lighting arrangements are shown in Figures 8B-13 and 8B-14. The bulbs may be replaced by removing the lamp lens attaching screws and lamp lens. The lamp housings may be replaced by removing housing attaching nuts or screws, or by removing nuts and bolts from bracket.

#### TAIL, STOP AND BACKUP LAMP BULBS

##### Replacement

1. Remove lens to housing attaching screws.
2. Replace bulb and check operation.
3. Position lens and install attaching screws.

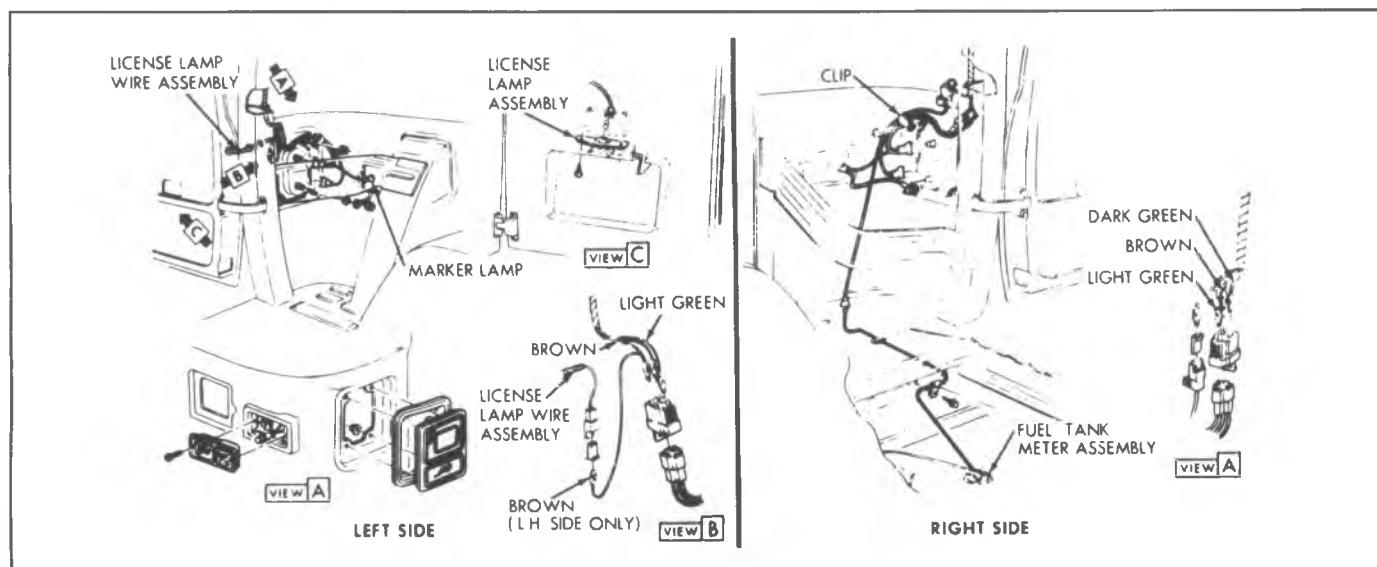

Fig. 8B-11--Rear Lighting (G Models)

## TAIL, STOP AND BACKUP LAMP HOUSING

C-K 16, 03 and 63 w/E63 and 06 Models

### All G Models

#### Replacement

1. Remove lens to housing attaching screws.
2. Remove bulbs from sockets.
3. Remove housing attaching screws (nuts on G Models).
4. Rotate wiring harness sockets counterclockwise and remove housing.
5. To install, reverse Steps 1-4 above.

## DIRECTIONAL SIGNAL LAMPS

Directional signal lamps are an integral part of parking and tail lamp assemblies. Refer to the applicable lamp or bulb replacement procedures covered previously.

## CLEARANCE, LICENSE PLATE AND IDENTIFICATION LAMPS

Refer to Figures 8B-16 and 8B-17 for clearance, license plate and identification lamp installations.

## LIGHT SWITCH

### C-K Series (Fig. 8B-18)

#### Replacement

1. Disconnect battery ground cable.
2. Reaching up behind instrument cluster, depress shaft retaining button and remove switch knob and rod.
3. Remove instrument cluster bezel screws on left end. Pull out on bezel and hold switch nut with a wrench.
4. Disconnect multiple wiring connectors at switch terminals.
5. Remove switch by rotating while holding switch nut.
6. To install, reverse Steps 1-5 above.

### G Series (Fig. 8B-18)

#### Replacement

1. Disconnect battery ground cable.
2. Reaching up behind instrument panel, depress shaft retaining button and remove switch knob-shaft.
3. From front of instrument panel remove switch retaining nut.
4. Push switch from panel opening and remove multiple electrical connector at switch terminals.
5. To install, reverse Steps 1-4, making sure grounding ring is installed on switch.

## NEUTRAL START SWITCH

### C-K Models (Fig. 8C-23)

#### Replacement and Adjustment

1. Disconnect battery ground cable.
2. Disconnect electrical harness at switch.
3. Remove switch mounting screws and remove switch.
4. Position shift lever in neutral gate notch.
5. Insert .096" (2.4mm) gage pin to depth of 3/8 inch (9.5mm) into switch gage hole. switch assembly is fixed in neutral position with internal plastic shear pin.
6. Assemble the switch to column by inserting the switch carrier tang in the shift tube slot and fasten in position by assembling mounting screws to retainers. If retainer strips out it must be replaced.
7. Remove .096" gage pin.
8. Move shift lever out of neutral gate notch to park gate position to shear switch internal plastic pin.
9. Return shift lever to neutral gate notch.
10. Switch (2.0mm) gage hole will freely admit .080" gage pin to a depth of 3/8 inch (9.5mm).
11. If pin will not freely enter gage hole, switch must be reset as below.
12. Connect battery ground cable and electrical harness.

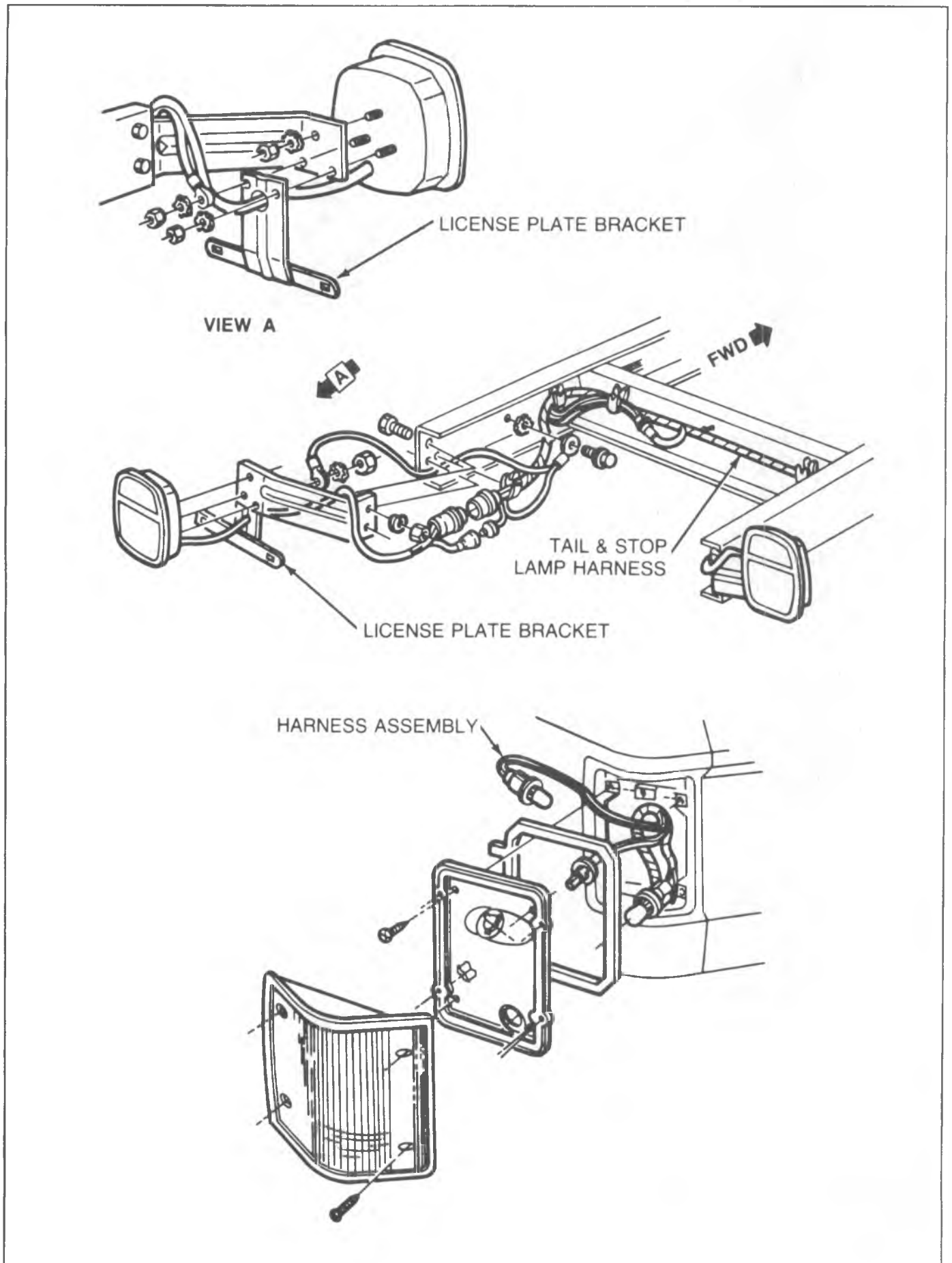

Fig. 8B-12--Rear Lighting (C-K Models Except with E56 or E62)

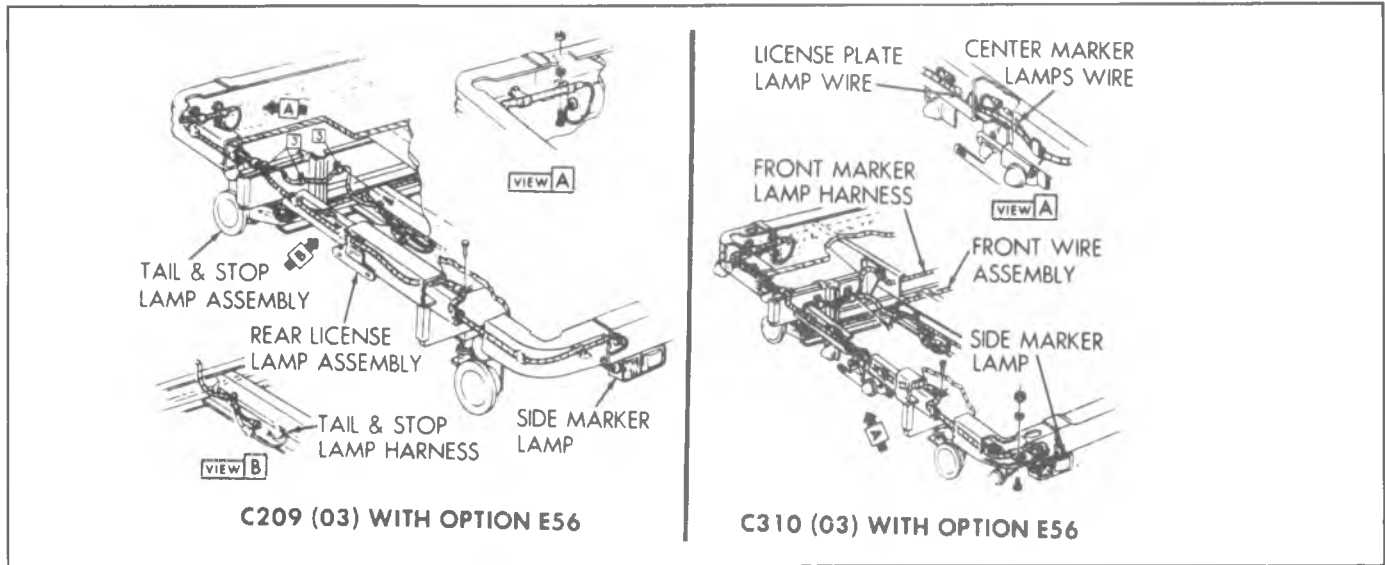

Fig. 8B-13--Rear Lighting (C-K Platform and Stake Rack Models)

**Reset Installation Procedure**

1. Place shift lever in neutral gate notch.
2. Loosen attaching screws.
3. Rotate switch on column and insert .096" (2.4mm) gage pin to depth of 3/8 inch (9.5mm).
4. Tighten attaching screws.
5. Repeat installation procedure Steps 7 through 12 above.

**G-P Series**

**Replacement (Fig. 8C-23)**

1. Raise vehicle on a hoist.
2. Disconnect the switch harness from the switch.
3. Remove switch mounting bolts and remove switch.
4. Assemble new switch loosely to mounting bracket.

5. Align .093/.097" (2.3/2.4mm) hole in Lever (B) with hole in Switch Assembly. Insert Pin (A) to hold in NEUTRAL position.
6. Set Transmission Lever (C) in NEUTRAL position by the following method.  
Obtain NEUTRAL by moving Transmission Lever counterclockwise to L1 detent, then clockwise three detents to the NEUTRAL detent position.
7. Install Rod into Transmission Lever and Switch Lever. Secure with clips.
8. Tighten switch attaching screws.
9. Lower vehicle from hoist and carefully check switch operation.

**BACKING LAMP SWITCH**

See "Neutral Start Switch" for automatic transmission models.

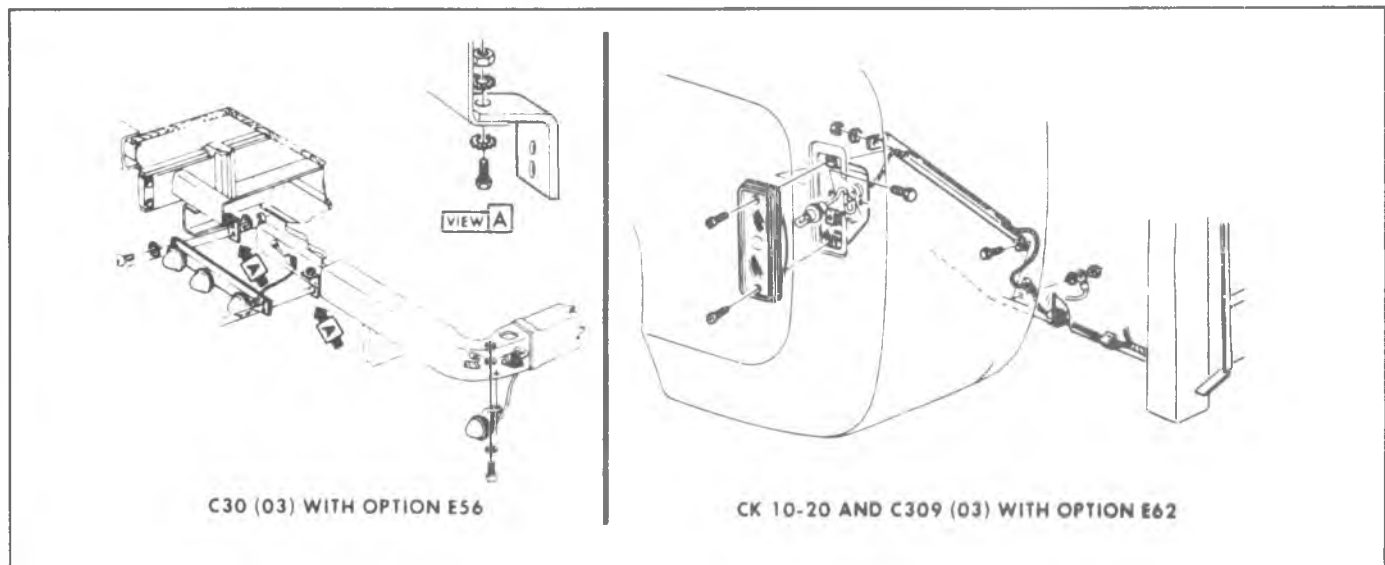

Fig. 8B-14--Rear Lighting (C30 03 Models with E56 and C-K Models with E62)

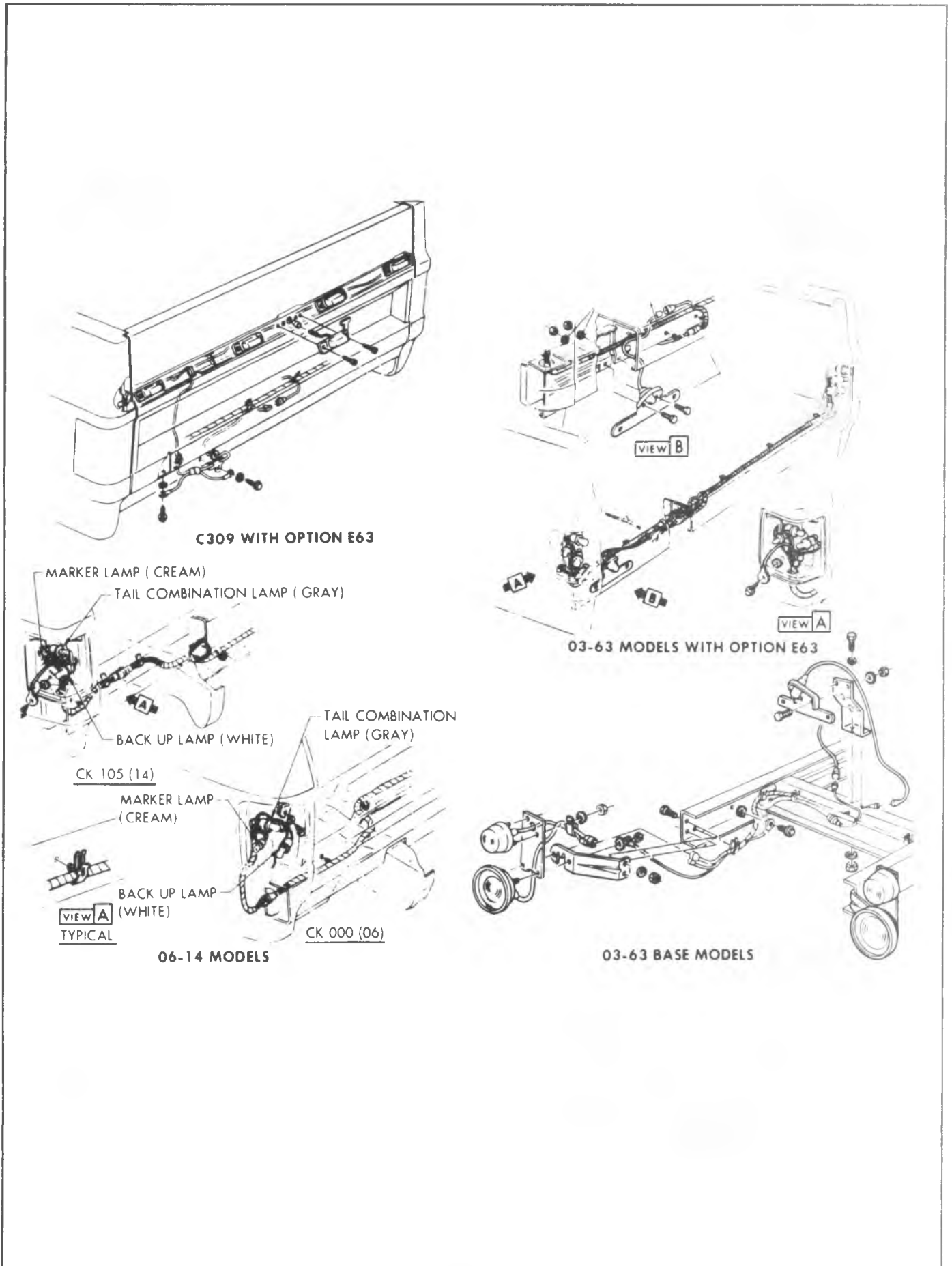

Fig. 8B-15--Rear Lighting CK 03 and 43 Models exc E62 or E6E

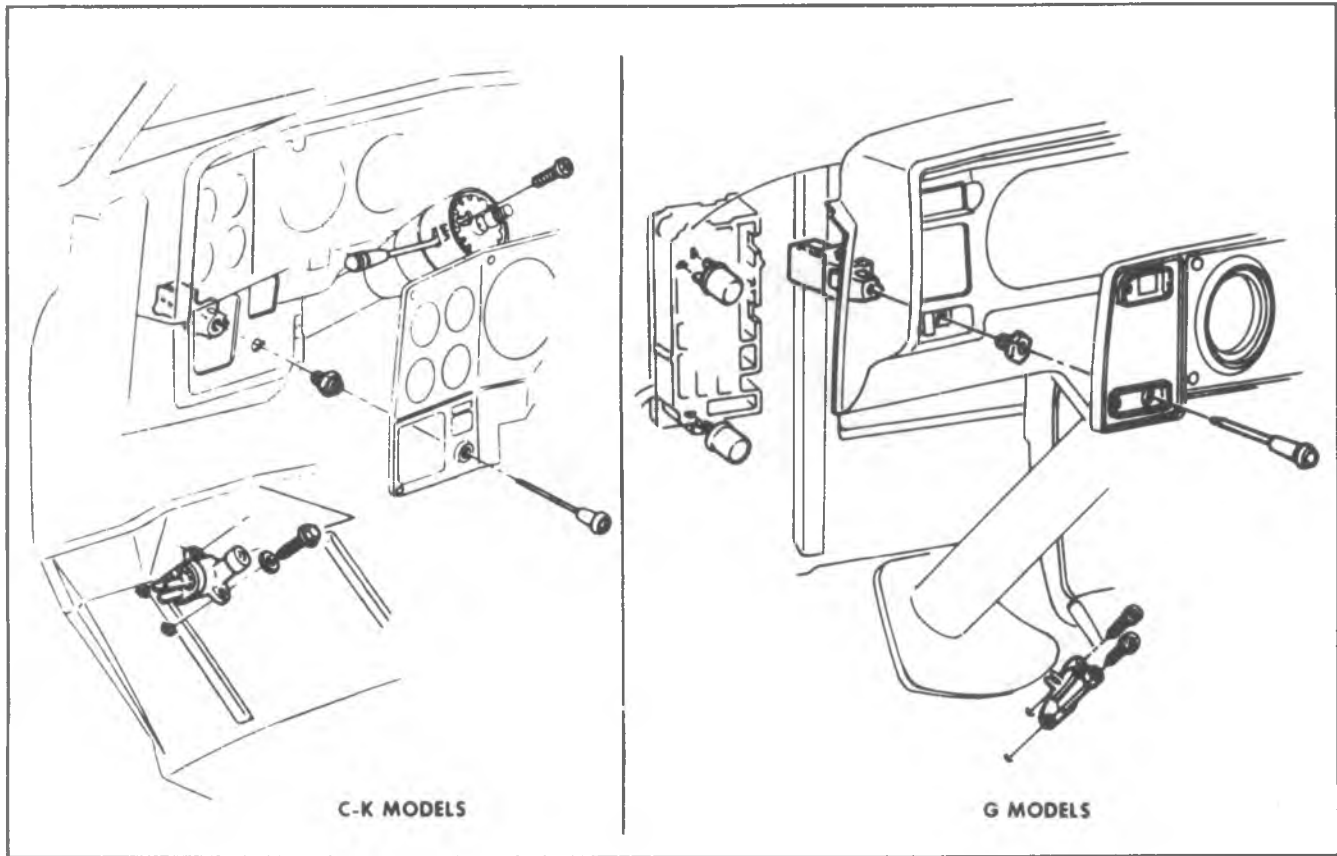

Fig. 8B-18--Light and Headlamp Beam Selector Switches

### Column Mounted Switch (Manual Transmission)

#### Replacement

1. Disconnect battery ground cable.
2. Disconnect switch wiring harness.
3. Remove column mounting screws and remove switch.
4. Assemble the switch to the column. Fasten in position by installing mounting screws.
5. Install battery ground cable.
6. Check operation to make sure back-up lights come on in reverse gear only.

### Transmission Mounted Switch

#### Replacement

1. Raise vehicle on a hoist.
2. Disconnect switch wiring harness.
3. Remove switch from transmission.
4. To install a new switch, reverse Steps 1-3 above.

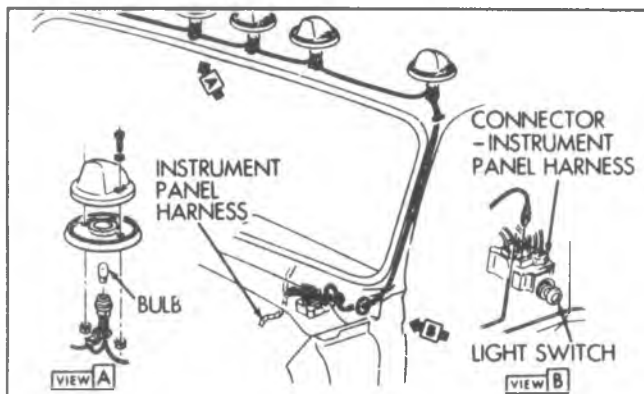

Fig. 8B-16--Clearance Lamps

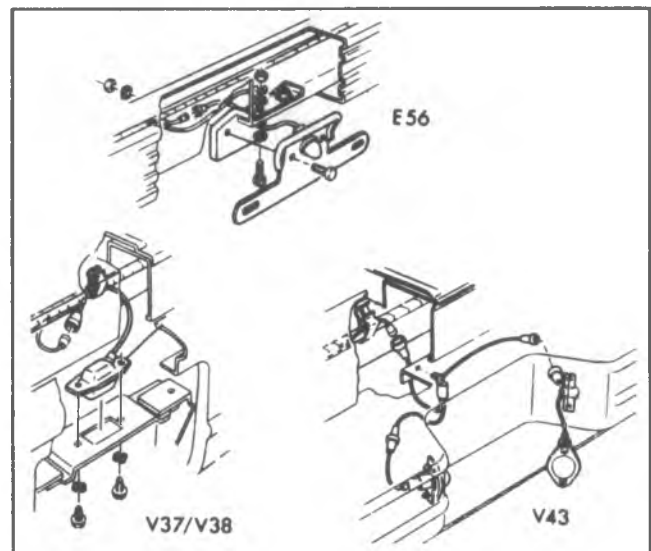

Fig. 8B-17--License Plate Lamps (C-K Series)

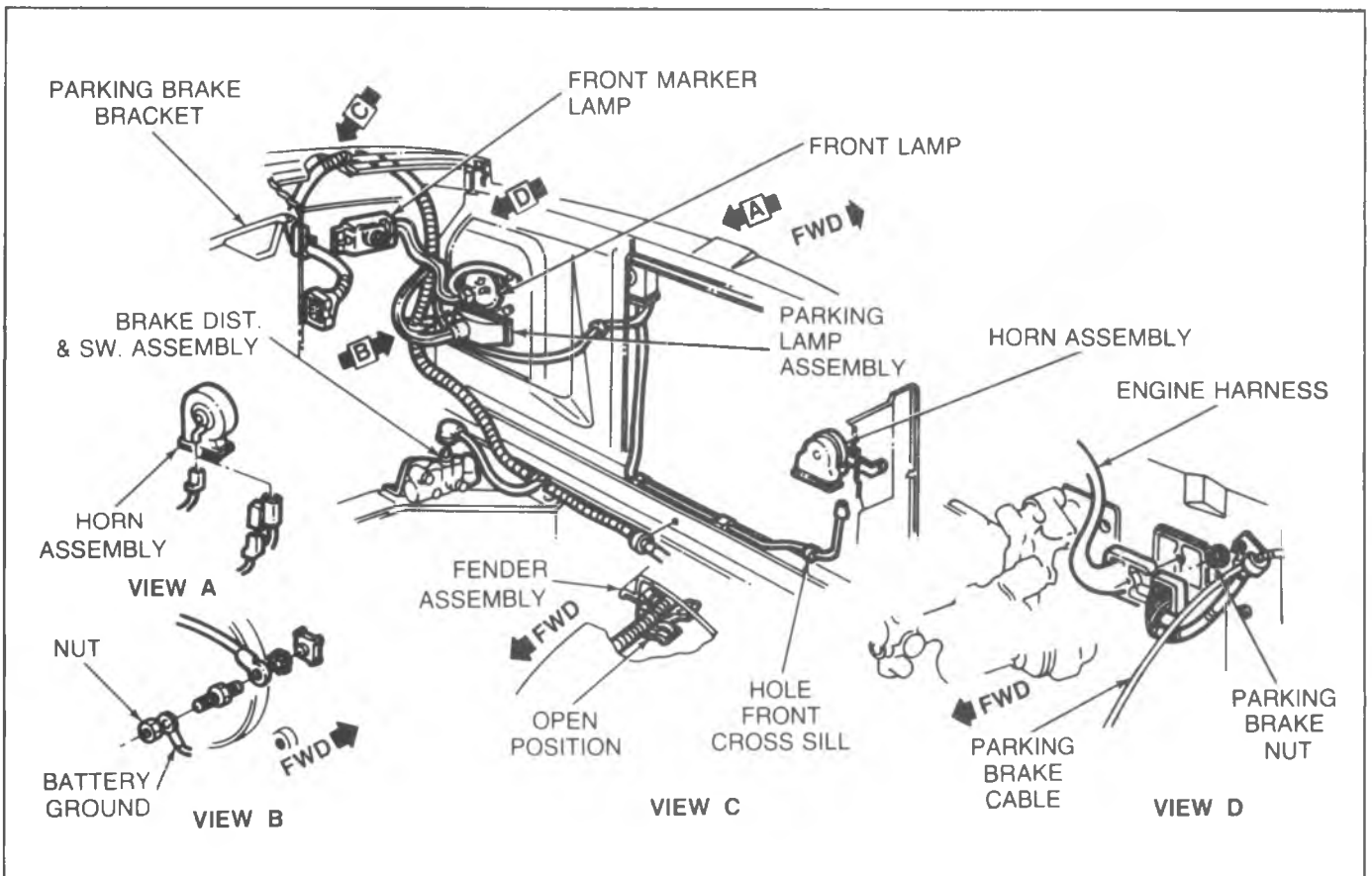

Fig. 8B-19--G Series Forward Lamp Wiring

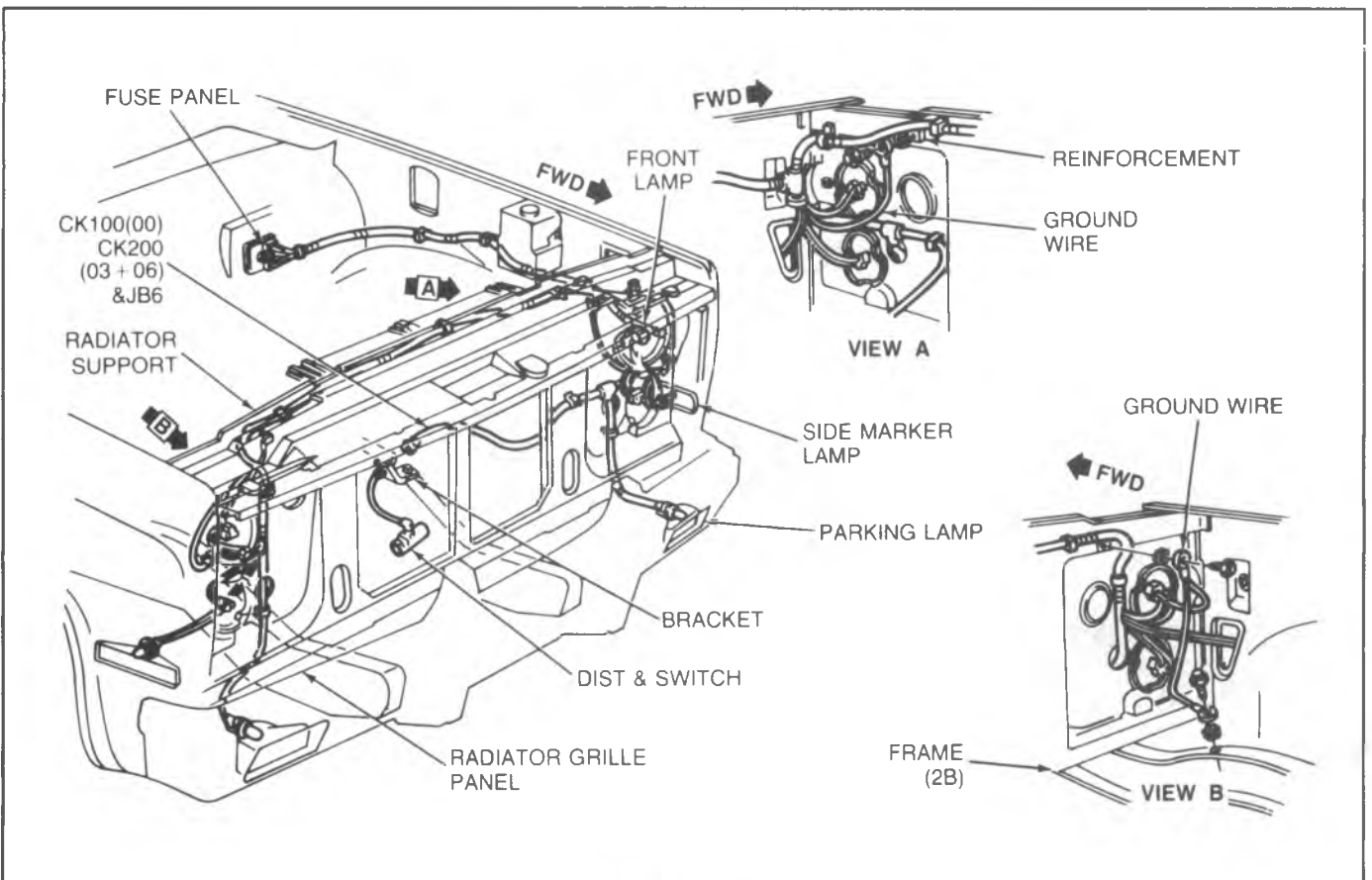

Fig. 8B-20--CK Series Forward Lamp Wiring



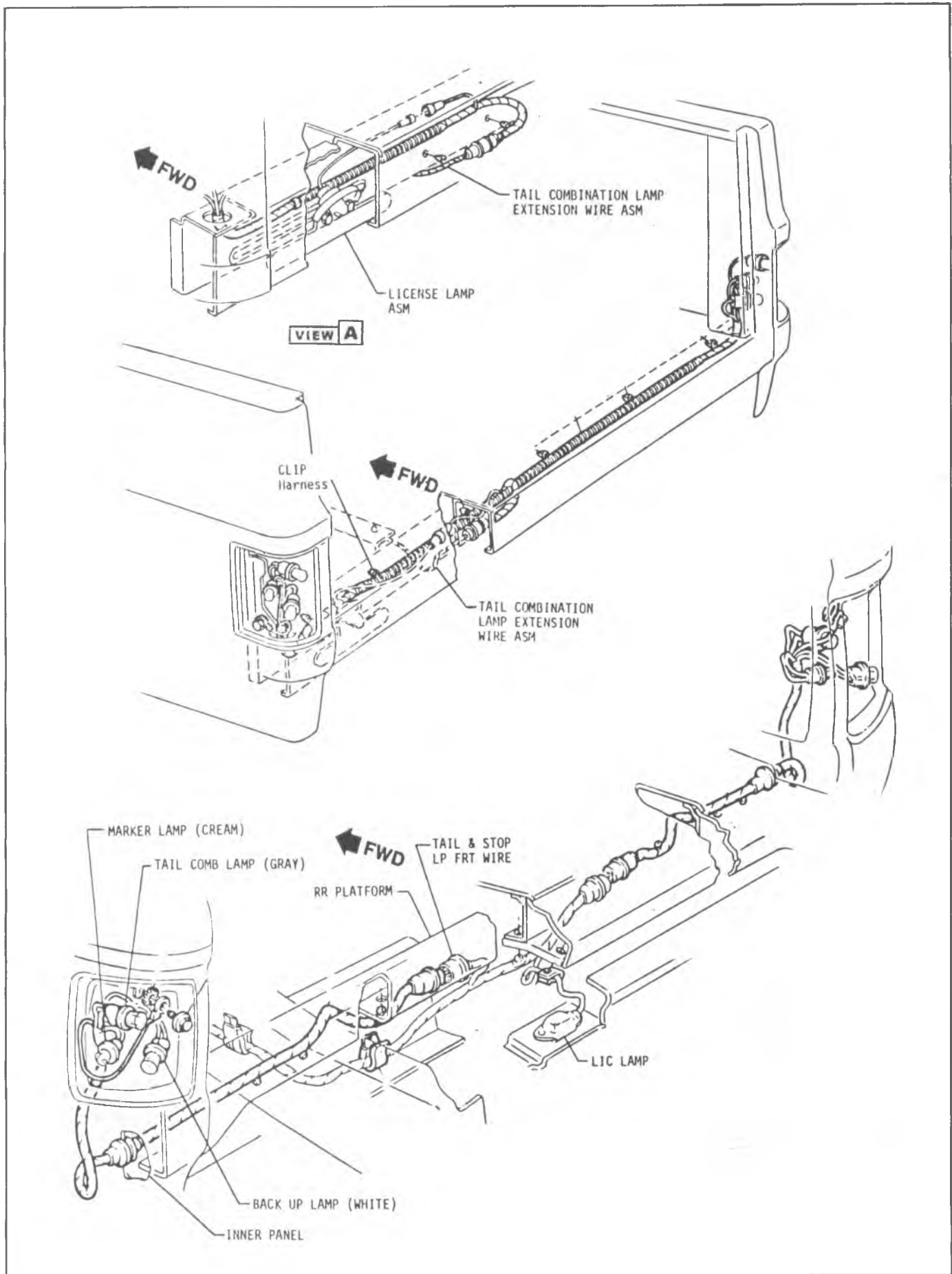

Fig. 8B-21--CK Series Rear Lamp Wiring

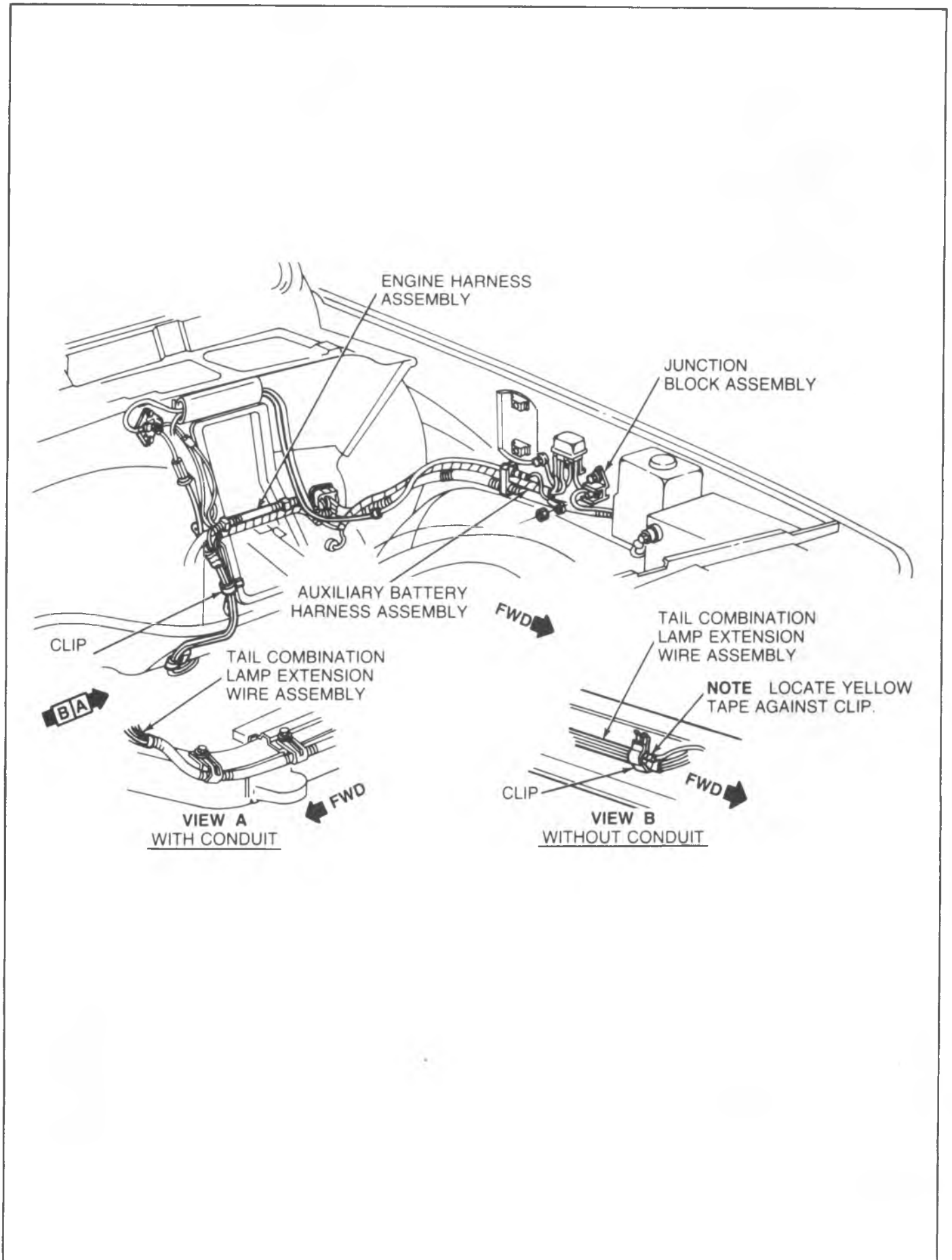

Fig. 8B-22--CK Series Auxiliary Wiring

## FUSES — CIRCUIT BREAKERS

The wiring circuits are protected from short circuits by a combination of fuses, circuit breakers, and fusible thermal links in the wiring itself. This greatly reduces the hazard of electrically caused fires in the vehicles.

The headlamp circuits are protected by a circuit breaker in the light switch. An electrical overload on the breaker will cause the lamps to go on and off, or in some cases to remain off.

In addition to a fuse, the windshield wiper motor is also protected by a circuit breaker. If the motor overheats, due to overloading caused by heavy snow, etc., the wipers will remain stopped until the motor cools.

Fuses located in the Junction Block beneath the dash on the drivers side are:

### C-K TRUCK

|  |        |
|--|--------|
| Heater, Front A/C, Generator Warning Lamp .....  | 20 Amp |
| Idle Stop Solenoid, Aux. Battery, Radio, Time Delay Relay, Emission Control Solenoid, Transmission Downshift (M40) .....                                 | 15 Amp |
| Cigarette Lighter, Clock, Dome Lamp, Cargo Lamp .....  | 20 Amp |
| Fuel Gauge, Brake Warning Lamp, Temperature Warning Lamp, Oil Pressure Warning Lamp .....  | 4 Amp  |
| Courtesy Lamp, Roof Marker Lamp, License Plate Lamp, Parking Lamp, Side Marker Lamp, Tail Lamp, Clearance Lamp .....                                     | 20 Amp |
| Directional Signal Indicator Lamp, Stop Lamp, Traffic Hazard .....   | 15 Amp |
| Instrument Cluster Lamp, Heater Dial Lamp, Radio Dial Lamp, Cruise Control Lamp, Windshield Wiper Switch Lamp .....                                      | 4 Amp  |
| Windshield Wiper/Washer .....  | 25 Amp |
| Cruise Control, Rear Window Aux., Fuel Tank, Tachometer, Back-up Lamp, Directional Signal Indicator Lamp, Directional Signal Lamp, Headlamp Buzzer ..... | 15 Amp |

### P TRUCK

|  |        |
|--|--------|
| Heater <sup>†</sup> , Air Conditioning <sup>†</sup> .....  | 25 Amp |
| Instrument Cluster Lamp, Windshield Wiper Switch Lamp .....  | 3 Amp  |
| Directional Signal Indicator Lamp, Stop Lamp, Traffic Hazard .....   | 15 Amp |
| Fuel Gauge, Brake Warning Lamp .....   | 3 Amp  |
| License Plate Lamp, Parking Lamp, Side Marker Lamp, Tail Lamp, Clearance Lamp, Identification Lamp .....   | 15 Amp |
| Windshield Washer/Wiper .....  | 25 Amp |
| Cigarette Lighter <sup>†</sup> , Clock <sup>†</sup> , Courtesy <sup>†</sup> , Dome Lamp <sup>†</sup> ..... | 15 Amp |
| Auxiliary Battery <sup>†</sup> , Back-up Lamp, Radio .....   | 15 Amp |

|  |        |
|--|--------|
| Idle Stop Solenoid, Cruise Control <sup>†</sup> , Directional Signal Lamp, Time Delay Relay, Emission Control Solenoid, Transmission Downshift (M40) ..... | 10 Amp |
|--|--------|

In-line fuses are located in the auxiliary heater circuits (C-K-P models) and underhood lamp, front and rear A/C circuits (C-K models)

<sup>†</sup>When incorporated by body builder

Do not use fuses of higher amperage than those recommended above

The following wiring harnesses are protected by a "fusible link" which is a special wire incorporated in the circuit headlamp hi-beam indicator, horn, air conditioning high blower, ignition circuits (C-K-P models) starter solenoid (pull-in and hold) circuit (C-K models). Should an electrical overload occur, this wire will fail and prevent damage to the major harness.

### G TRUCK

|   |        |
|---|--------|
| Heater, A/C .....   | 25 Amp |
| Idle Stop Solenoid, Cruise Control, Directional Signal Lamp, Directional Signal Indicator Lamp, Transmission Downshift (M-40) .....                     | 10 Amp |
| Cigarette Lighter, Dome Lamp, Spot Lamp ...   | 15 Amp |
| Fuel Gauge, Brake Warning Lamp, Temperature Warning Lamp, Generator Warning Lamp, Oil Pressure Warning Lamp   | 3 Amp  |
| Stop Lamp, Traffic Hazard .....   | 15 Amp |
| Auxiliary Battery, Backing Lamp, Radio Dial Lamp, Radio .....   | 15 Amp |
| Instrument Cluster Lamp, Heater Dial Lamp, Transmission Control Lamp with Tilt Wheel, Cruise Control Lamp, W/S Wiper Switch Lamp, Headlamp Buzzer ..... | 3 Amp  |
| License Lamp, Parking Lamp, Side Marker Lamp, Tail Lamp .....   | 15 Amp |
| Windshield Wiper .....  | 25 Amp |

An in-line fuse is located in the Ammeter and the auxiliary heater circuits.

Do not use fuses of higher amperage rating than those recommended above

The following wiring harnesses are protected by a "fusible link" which is a special wire incorporated in the circuit, ignition, horn and headlamp hi-beam indicator circuits, air conditioning high blower. Should an electrical overload occur, this wire will fail and prevent damage to the major harness.

## CIRCUIT BREAKERS

| DEVICE OR CIRCUIT PROTECTED       | MODELS  | AMPERES | LOCATION            |
|-----------------------------------|---------|---------|---------------------|
| Headlamp and parking lamp circuit | C-K-P-G | 15      | Light switch        |
| Tailgate window motor             | C-K     | 30      | Dash (forward side) |
| Rear A/C (C69 overhead)           | G       | 35      | Dash (forward side) |

## SPECIFICATIONS

LAMP BULB DATA  
C-K-P TRUCK

| USED IN  | QUANTITY | TRADE # | POWER   |
|--|----------|---------|---------|
| Dome Lamps:  |          |         |         |
| Cab  | 1        | 1004    | 15 CP   |
| Utility & Suburban                                 | 1        | 211-2   | 12 CP   |
| Oil Pressure indicator lamp <sup>1</sup>           | 1        | 168     | 3 CP    |
| Generator indicator lamp <sup>1</sup>              | 1        | 168     | 3 CP    |
| Instrument cluster lamps <sup>2</sup>              | 5        | 168     | 3 CP    |
| Headlamp beam indicator lamp                       | 1        | 168     | 3 CP    |
| Lamp assembly - tail & stop lamp                   | 2        | 1157    | 3-32 CP |
| License Lamp <sup>4</sup>                          | 1        | 67      | 4 CP    |
| Directional signal (front park lamps) <sup>6</sup> | 2        | 1157    | 3-32 CP |
| Head Lamps   | 2        | 6014    | 50-60 W |
| Temperature indicator lamp                         | 1        | 168     | 3 CP    |
| Directional signal indicator lamp                  | 2        | 168     | 3 CP    |
| Clearance and marker lamps                         | 4        | 168     | 3 CP    |
| Roof marker lamps <sup>5</sup>                     | 5        | 194     | 2 CP    |
| Brake warning indicator                            | 1        | 168     | 3 CP    |
| Transmission control (auto)                        | 1        | 1445    | 0.7 CP  |
| Backing lamp (exc. motor home)                     | 2        | 1156    | 32 CP   |
| Backing lamp (motor home)                          | 2        | 1295    | 50 CP   |
| Heater or A/C                                      | 1        | 161     | 1 CP    |
| Corner marker lamps (platform)                     | 7        | 67      | 4 CP    |
| Cargo lamp (C-K cab)                               | 1        | 1142    | 21 CP   |
| Radio dial lamp - AM                               | 1        | 1816    | 3 CP    |
| - AM/FM  | 1        | 216     | 1 CP    |
| Courtesy lamp                                      | 1        | 1003    | 15 CP   |
| Windshield wiper switch                            | 1        | 161     | 1 CP    |
| Clock  | 1        | 168     | 3 CP    |
| Rear identification <sup>7</sup>                   | 10       | 1895    | 2 CP    |
| Underhood lamp                                     | 1        | 93      | 15 CP   |
| Seat belt warning                                  | 1        | 168     | 3 CP    |
| Cargo/dome lamp                                    | 2        | 211-2   | 12 CP   |
| Four wheel drive indicator                         | 1        | 161     | 1 CP    |
| Choke heater Ind                                   | 1        | 168     | 3 CP    |

1 On CA, KA 10-35 instrument clusters only.

2 3 lamps used on instrument cluster on P models or C-K w/o gauges.

3 Double filament sealed beam 60W high beam, 50W low beam.

4 2 lamps used with step bumper and P models.

5 4 required on P models.

6 1157 NA, 2.2-24 CP on C-K models.

7 Wideside Pickup.

8 'P' truck only.

LAMP BULB DATA  
G TRUCK

| USED IN                                | QUANTITY | TRADE# | POWER   |
|--|----------|--------|---------|
| Dome lamps                             | 2        | 211-2  | 12 CP   |
| Oil pressure indicator lamp            | 1        | 161    | 1 CP    |
| Generator indicator lamp               | 1        | 194    | 2 CP    |
| Instrument cluster lamps <sup>11</sup> | 1        | 161    | 1 CP    |
| Headlamp beam indicator lamp           | 1        | 161    | 1 CP    |
| Park, directional signal lamps         | 2        | 1157   | 3-32 CP |
| Tail, stop lamps                       | 2        | 1157   | 3-32 CP |
| License lamp                           | 1        | 67     | 4 CP    |
| Head lamps <sup>12</sup>               | 2        | 6014   | 50-60 W |
| Temperature indicator lamp             | 1        | 194    | 2 CP    |
| Directional signal indicator lamp      | 2        | 194    | 2 CP    |
| Marker lamps                           | 4        | 168    | 3 CP    |
| Brake warning indicator lamp           | 1        | 194    | 2 CP    |
| Back-up lamp                           | 2        | 1156   | 32 CP   |
| Radio dial lamp                        | 1        | 1893   | 2 CP    |
| Heater or A/C control                  | 1        | 194    | 2 CP    |
| Transmission control w/tilt wheel      | 1        | 1445   | 0.7 CP  |
| W/S wiper switch lamp                  | 1        | 161    | 1 CP    |
| Transmission control                   | 1        | 73     | 3 CP    |
| Choke heater ind                       | 1        | 1893   | 2 CP    |
| Seat belt warning                      | 1        | 194    | 2 CP    |
| Instrument cluster lamps <sup>9</sup>  | 5        | 194    | 2 CP    |
| Instrument cluster lamps <sup>10</sup> | 1        | 168    | 3 CP    |

<sup>9</sup> 'G' model w/o gauges; 1 lamp with gauges

<sup>10</sup> 'G' model w/o gauges; 3 lamps with gauges

<sup>11</sup> 'G' model with gauges only

<sup>12</sup> Double filament sealed beam 60W high beam, 50W low beam.

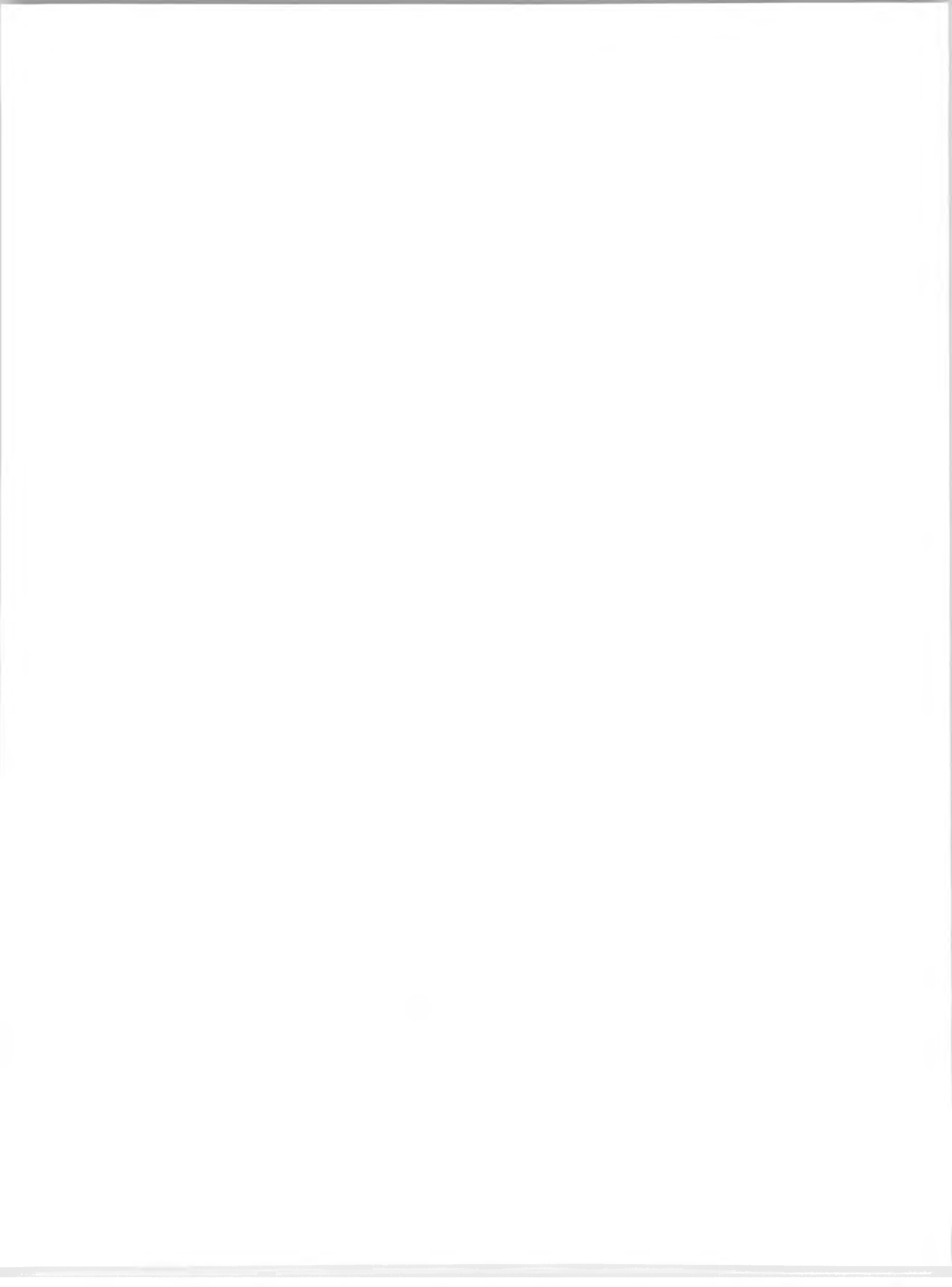

## SECTION 8C

# INSTRUMENT PANEL AND GAGES

### CONTENTS

|  |       |   |       |
|--|-------|---|-------|
| Instrument Panel and Gages.....                    | 8C-1  | General Description.....                    | 8C-19 |
| General Description.....                           | 8C-1  | Electrical Circuits.....                    | 8C-20 |
| Diagnosis.....                                     | 8C-2  | Diagnosis.....                              | 8C-22 |
| On-Vehicle Service.....                            | 8C-6  | Wiper - On Vehicle.....                     | 8C-22 |
| Windshield Wiper/Wiper/Washer Switch.....          | 8C-6  | Wiper - Off Vehicle.....                    | 8C-22 |
| Ignition Switch.....                               | 8C-6  | On Vehicle Service.....                     | 8C-32 |
| Instrument Cluster.....                            | 8C-6  | Wiper Motor.....                            | 8C-32 |
| Indicator and Illuminating Bulbs.....              | 8C-9  | Unit Repair.....                            | 8C-32 |
| Laminated (Printed) Circuit.....                   | 8C-9  | Wiper/Washer Disassembly.....               | 8C-32 |
| Speedometer.....                                   | 8C-9  | Motor Disassembly.....                      | 8C-32 |
| Speedometer Cable Core.....                        | 8C-10 | Motor Assembly.....                         | 8C-32 |
| Fuel Gauge.....                                    | 8C-10 | Wiper Adjustments.....                      | 8C-32 |
| Temperature Gauge.....                             | 8C-10 | Washer Pump.....                            | 8C-33 |
| Temperature Sending Unit.....                      | 8C-10 | Windshield Wiper and Washer (P Models)..... | 8C-37 |
| Oil Pressure Gauge.....                            | 8C-10 | General Description.....                    | 8C-37 |
| Oil Pressure Sending Unit.....                     | 8C-11 | Diagnosis.....                              | 8C-39 |
| Voltmeter.....                                     | 8C-12 | Wiper - On Vehicle.....                     | 8C-39 |
| Radio Receiver.....                                | 8C-14 | Unit Repair.....                            | 8C-44 |
| Directional Signal Switch.....                     | 8C-17 | Wiper Motor.....                            | 8C-44 |
| Instrument Panel Wiring Harnesses.....             | 8C-17 | Windshield Washer.....                      | 8C-45 |
| Windshield Wiper and Washer(C-K and G Models)..... | 8C-19 |   |       |

### GENERAL DESCRIPTION

All instruments and gages are installed in the instrument cluster. Instruments and gages can be serviced in the vehicle (C-K Series); however, the entire cluster must be removed from the vehicle for servicing of the instruments and gages (G Series). Illuminating and indicator lamps may be replaced without removing the cluster from the vehicle.

Bulbs are installed in plastic holders which lock into the cluster housing.

Regular maintenance is not required on the instrument cluster or its components other than maintaining clean, tight electrical connections, replacing defective parts and keeping the speedometer cable properly lubricated.

# DIAGNOSIS

## OIL PRESSURE GAGE DIAGNOSIS

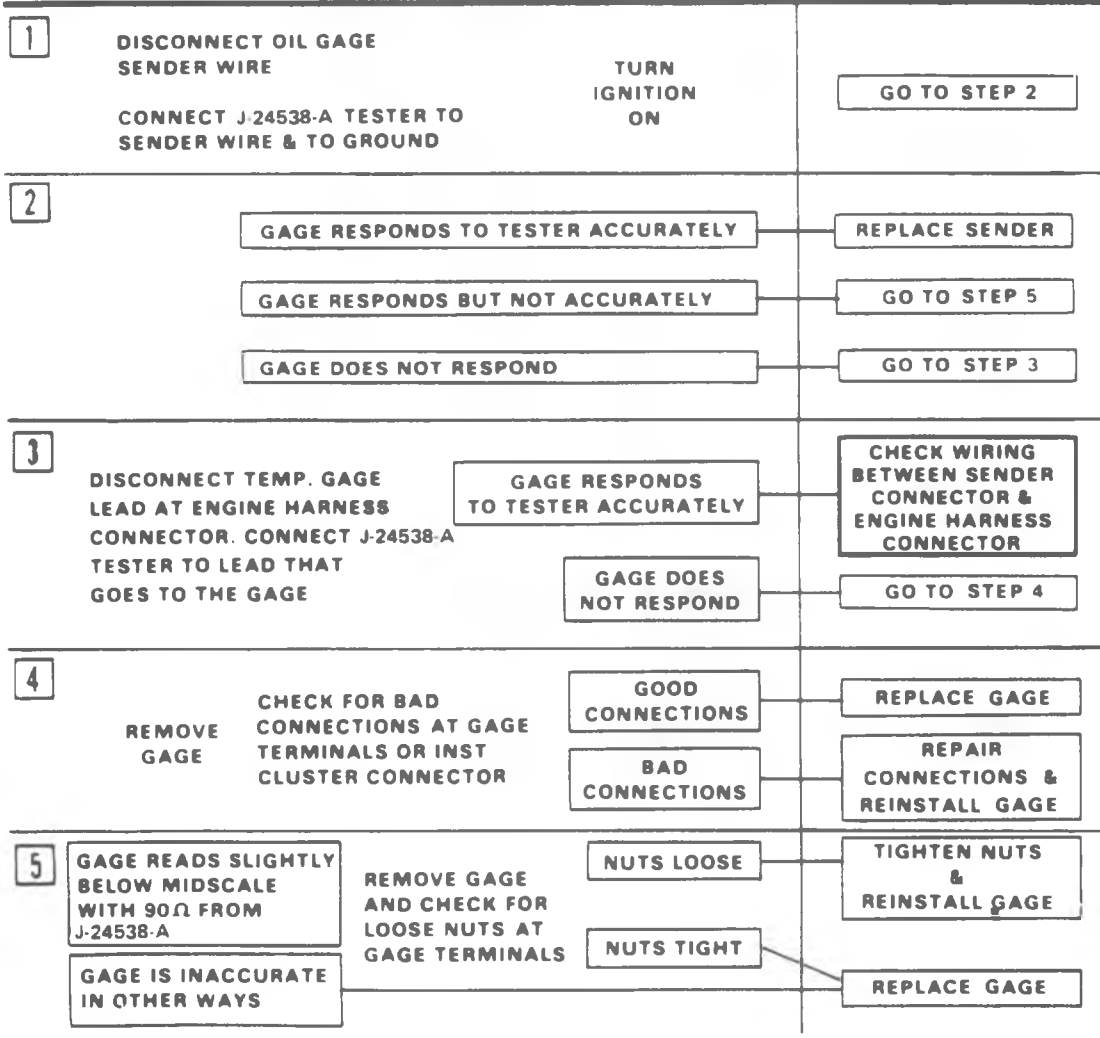

## TEMPERATURE GAGE DIAGNOSIS

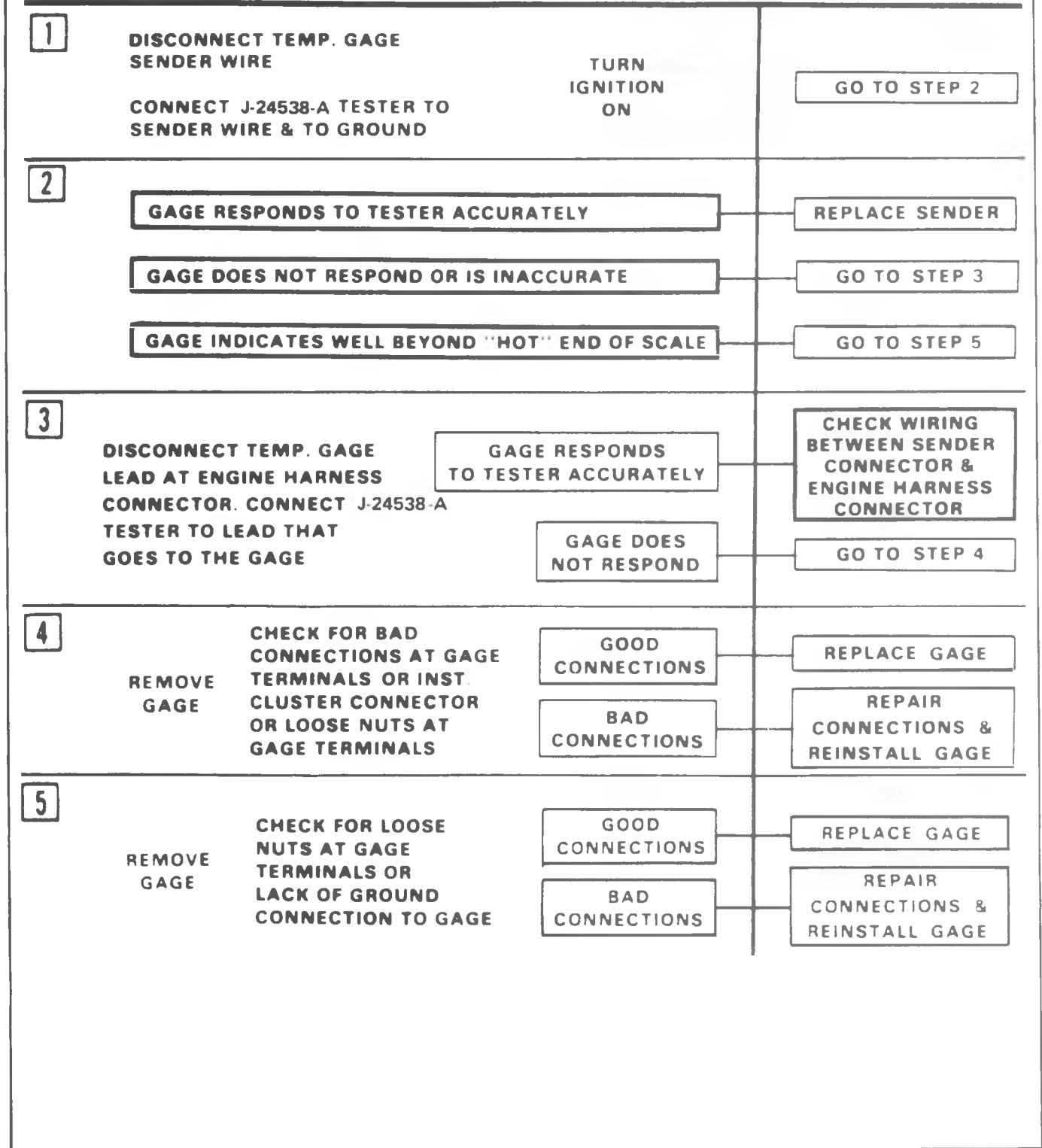



## FUEL GAGE DIAGNOSIS

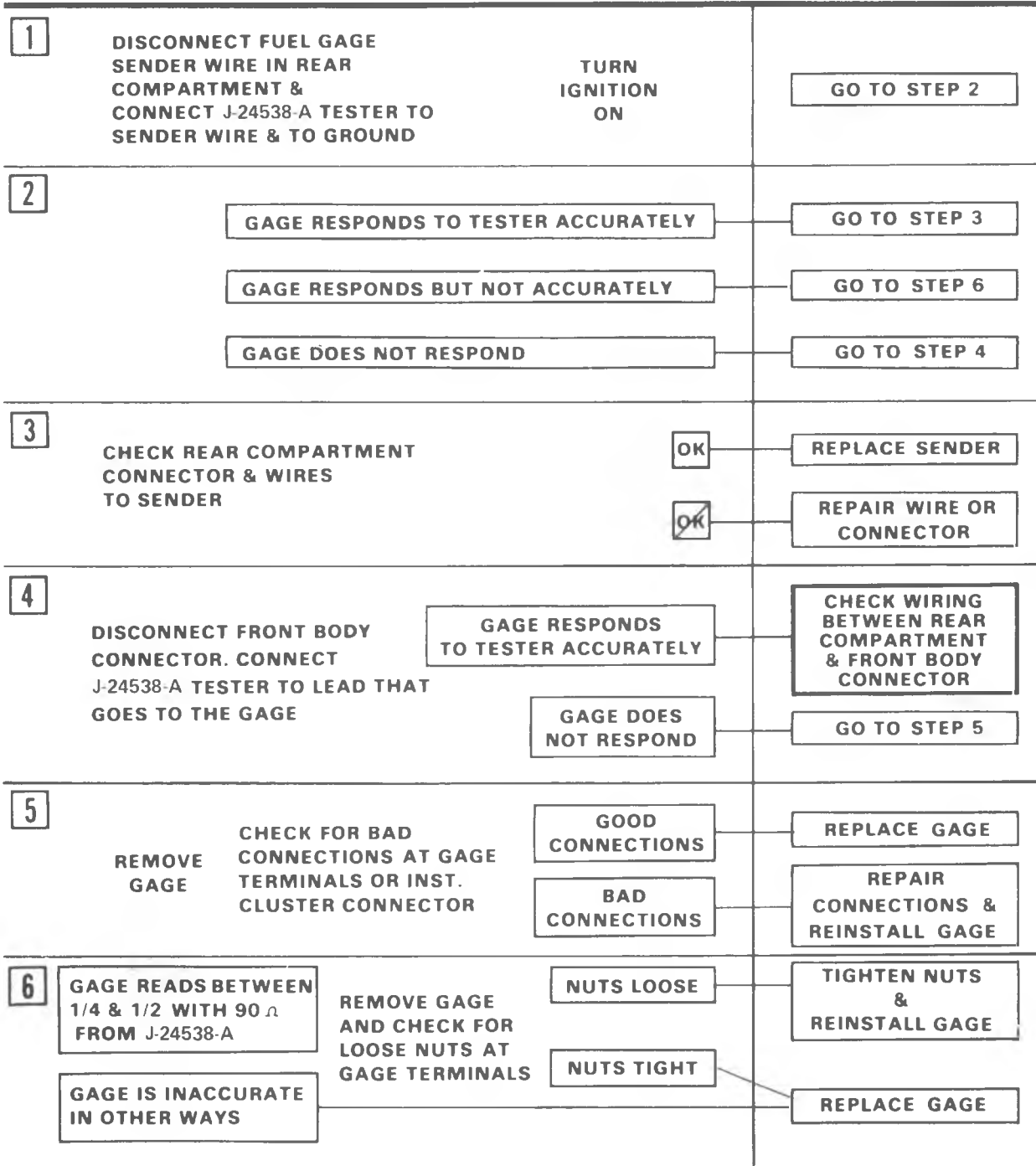

## DIAGNOSIS - SPEEDOMETER SYSTEM

| COMPLAINT  | POSSIBLE CAUSE  | PROCEDURE   |
|--|---|---|
| Noisy  | Kinked, pinched or burned casings.                            | Replace both the cable and casing. Recheck for noise.   |
| "  | Bent cable tips.  | Replace both the cable and casing. Recheck for noise.   |
| "  | Improper or insufficient lubrication of cable.                | Lubricate cable core with P/N 6478535 or equivalent. Pack ferrule with grease.  |
| "  | Faulty driven gear or rough drive gear.                       | Remove driven gear assembly from transmission. Check for free rotation of gear in sleeve. Check for burrs, flash or unusual worn spots. If gears appears faulty, replace and recheck for noise. |
| Whine  | Oversize driven gear stem in transmission binds with adapter. | Replace driven gear and stem.   |
| Buzzing sound with manual transmission.                        | Shift linkage vibration.                                      | Adjust transmission shift linkage.  |
| Tick or ringing sound with jumpy pointer between 0 and 30 MPH. | Faulty speedometer head.                                      | Remove speedometer head for repair.   |
| Sticky speedometer pointer.                                    | Speedometer pointer is bent and rubs.                         | Remove speedometer cluster or lens and straighten pointer. Recheck speedometer operation.   |
| Incorrect calibration.   | Wrong transmission adapter, drive gear or sleeve.             | Check speedometer gear reference for correct application and replace if necessary.  |
| "  | Oversize or undersize tires.                                  | Check calibration using correct tire size.  |
| "  | Faulty speedometer head.                                      | Remove speedometer for repair.  |

## ON-VEHICLE SERVICE

### WINDSHIELD WASHER / WIPER SWITCH

#### C-K Models

##### Replacement

1. Disconnect battery ground cable.
2. Remove instrument panel bezel screws and bezel.
3. Remove switch attaching screws.
4. Pull out on switch assembly and disconnect electrical harness - remove switch.
5. To install, reverse Steps 1-4 above. Check switch operation before reinstalling instrument panel bezel.

#### G Models

##### Replacement

1. Disconnect battery ground cable.
2. Reach up behind left side of instrument panel, and:
  - a. Remove plug connector from rear of switch.
  - b. Remove (3) mounting screws securing bezel and ground wires to switch.
3. Replace switch, installing ground wire and connector. Check operation of switch, first observing washer solvent level.

### IGNITION SWITCH

See Section 3B - Steering, for ignition switch replacement procedure.

### INSTRUMENT CLUSTER

#### C-K Series

##### Replacement (Fig. 8C-1)

1. Disconnect battery ground cable.
2. Remove headlamp switch control knob.
3. Remove radio control knobs.
4. Remove four screws and remove steering column cover.
5. Remove eight screws and remove instrument bezel.
6. Reach up under instrument cluster and disconnect speedometer by first depressing tang on rear of speedometer head, then pulling cable free from head as tang is depressed.
7. Remove cluster to bench for further disassembly (laminated printed circuit, speedometer head, gages).
8. Install cluster in reverse order of removal.

#### G Series

##### Replacement (Fig. 8C-3)

1. Disconnect battery ground cable.
2. Reach up under instrument cluster and disconnect speedometer cable by first depressing tang on rear of speedometer head, then pulling cable free from head as tang is depressed.
3. Remove clock set stem knob.

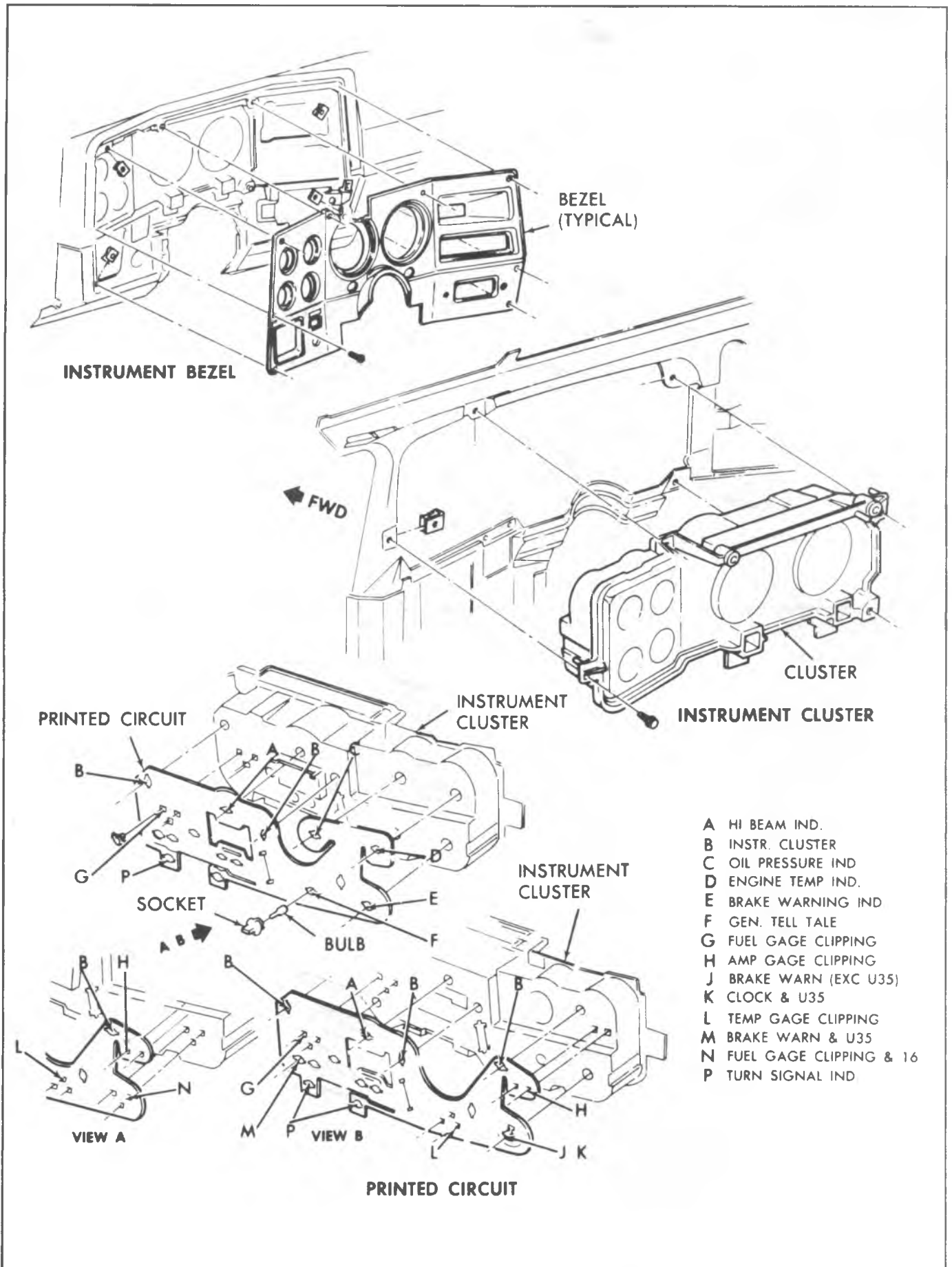

Fig. 8C-1--Instrument Cluster Assembly (C-K Series)

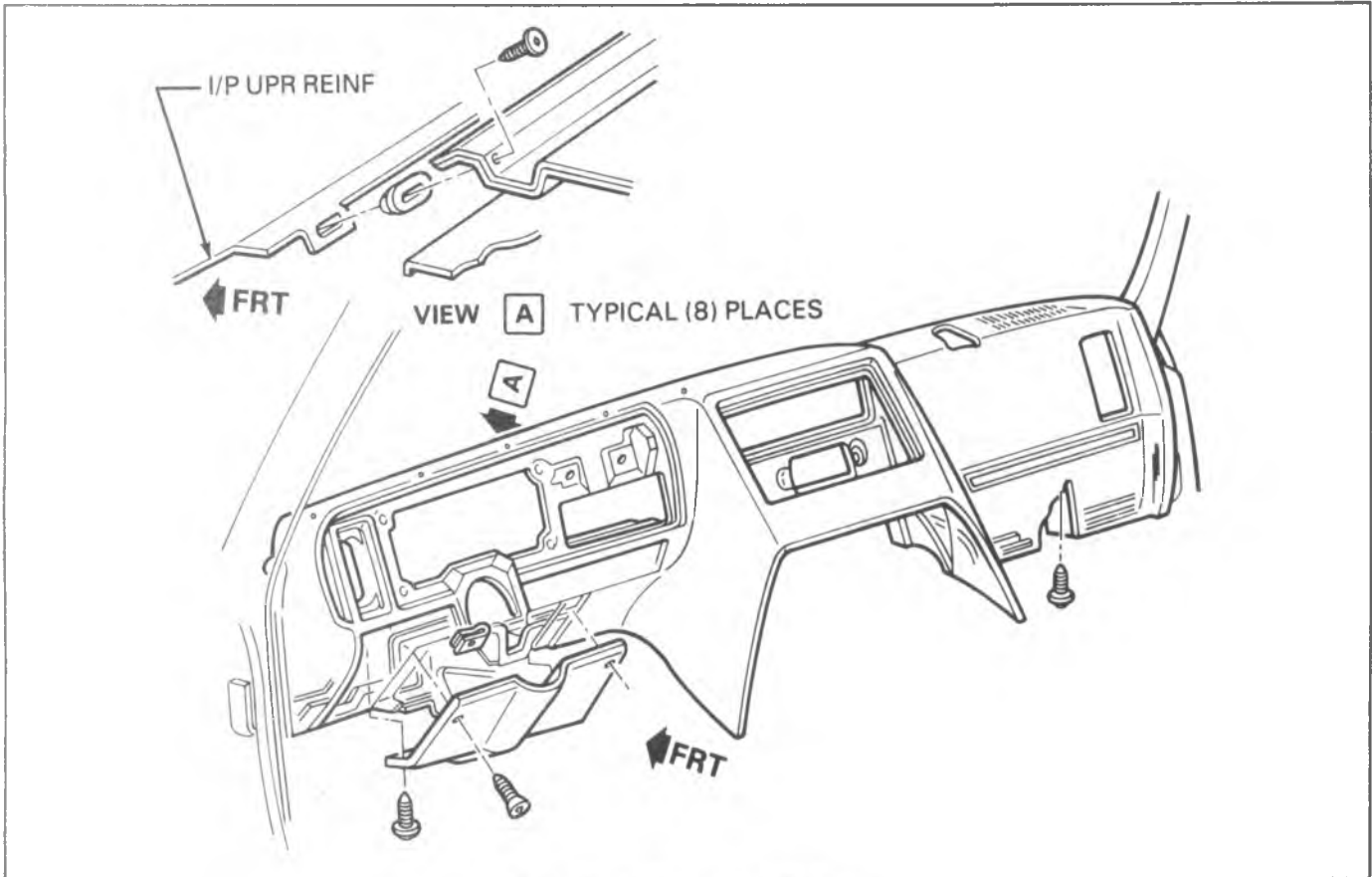

Fig. 8C-2--Instrument Panel (G Series)

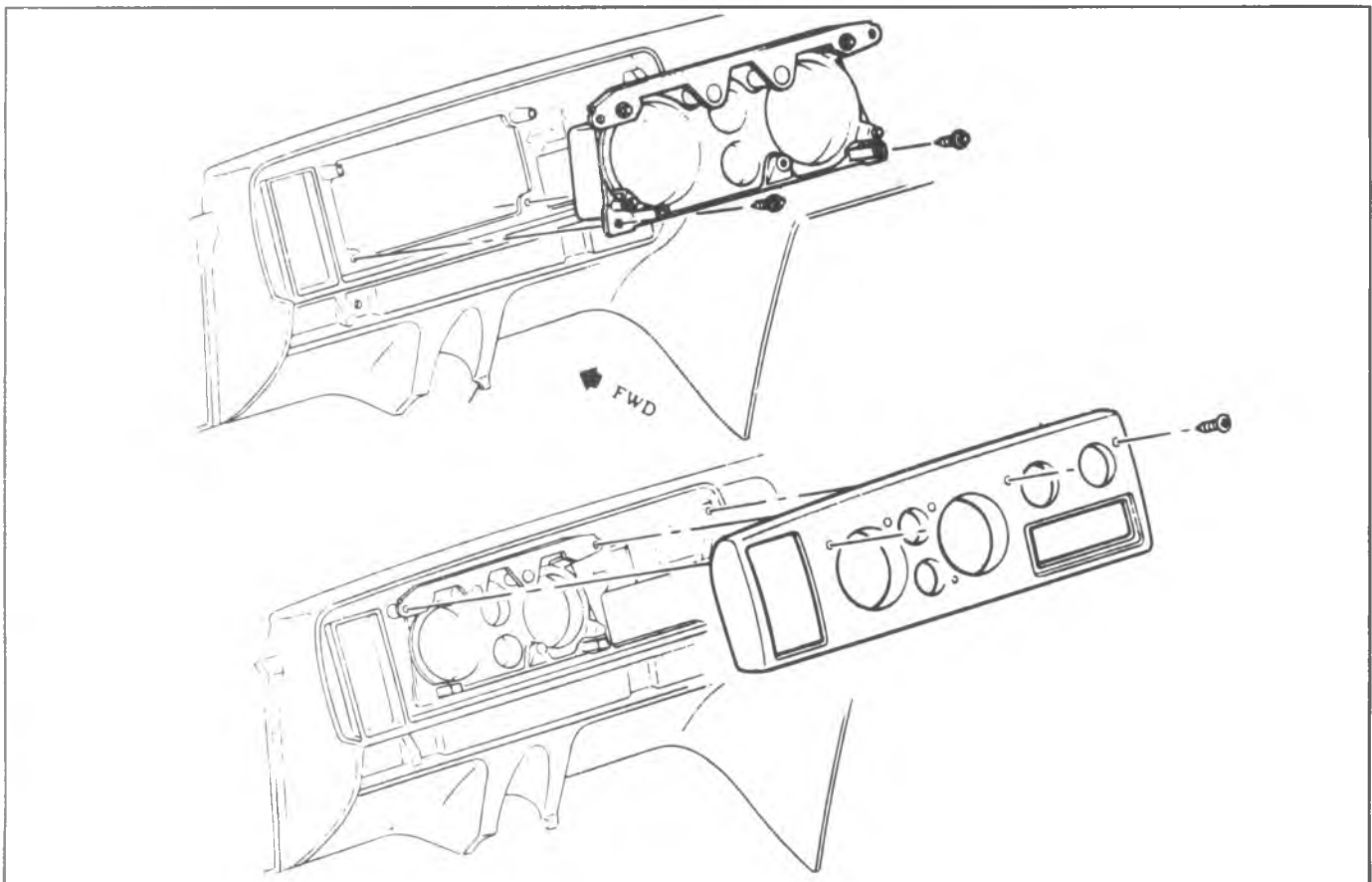

Fig. 8C-3--Instrument Cluster Assembly (G Series)

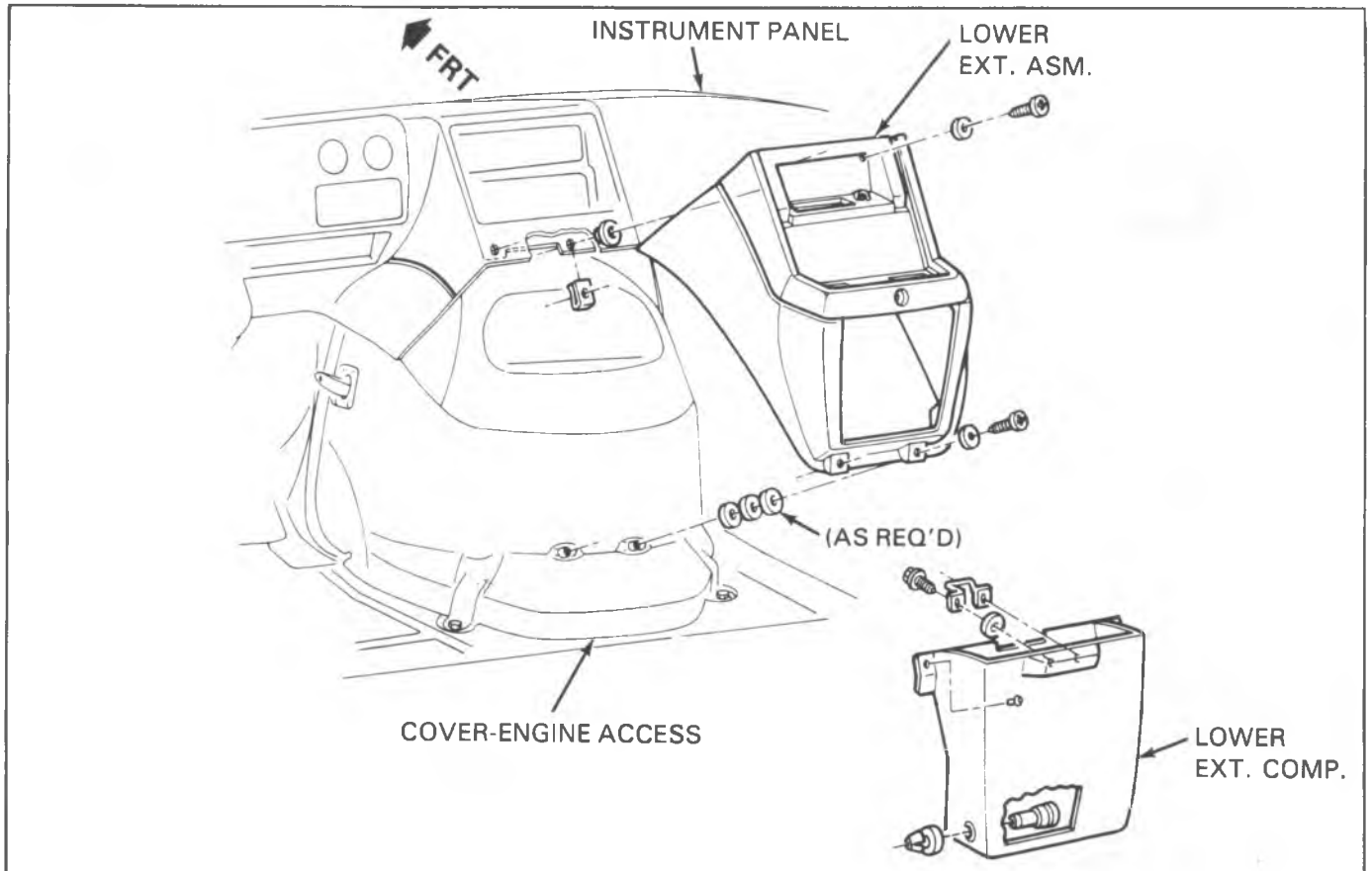

Fig. 8C-4-1.P. Lower Extension Asm-(G Series)

4. Remove screws attaching instrument cluster bezel to instrument panel and remove bezel.
  5. Remove two lower cluster attachment screws.
  6. Pull top of cluster away from instrument panel and lift out bottom of cluster.
  7. Unplug instrument panel harness connector from printed circuit.
  8. Remove cluster to bench for further disassembly (laminated printed circuit, speedometer head, gages).
2. Remove all instrument cluster lamp bulb assemblies.
  3. Remove laminated circuit retaining screws.  
These screws serve as a ground for the circuit and must be reinstalled to provide the proper connection of the gage terminals to the printed circuit.
  4. **G Series** - Remove fuel, temperature and ammeter terminal nuts retaining laminated circuit to rear of cluster.
  5. Lift laminated circuit from cluster cover.
  6. To install, reverse Steps 1-5 and check electrical operation of all affected components.

## INDICATOR AND ILLUMINATING BULBS

### All Models

#### Replacement (Figs. 8C-1 and 8C-3)

1. Reach up under instrument panel and turn bulb holder counterclockwise to remove from cluster housing.
2. Pull bulb straight out to remove from holder.
3. Install replacement bulb in holder, press inward to lock in place.
4. Insert holder into housing, with lugs on holder entering notches in case, and turn clockwise to lock holder against printed circuit.

## LAMINATED (PRINTED) CIRCUIT

### All Models

#### Replacement

1. Remove instrument cluster assembly as previously described in this section.

## SPEEDOMETER

Servicing of the speedometer assembly should only be performed by trained technicians having the proper test equipment.

When replacing a speedometer or odometer assembly, the law requires the odometer reading of the replacement unit to be set to register the same mileage as the prior odometer. If the same mileage cannot be set, the law requires the replacement odometer be set to zero and a label be installed on the driver's door frame to show the previous odometer reading and the date of replacement.

### C-K Models

#### Replacement

1. Disconnect battery ground cable.
2. Remove headlamp switch control knob.
3. Remove radio control knobs and clock adjuster stem.
4. Remove instrument cluster bezel and steering column

cover.

5. Remove instrument cluster lens.
6. Remove transmission PRNDL indicator and case front cover.
7. Remove speedometer to cluster screws and speedometer assembly.
8. To install, reverse removal procedure. Check speedometer operation.

### **G Series**

#### **Replacement**

1. Remove instrument cluster as previously described in this section.
2. Remove screws retaining speedometer dial to cluster case.
3. Remove two hex head screws and rubber grommets securing speedometer assembly to cluster cover.
4. To install, reverse removal procedure and check operation of speedometer assembly.

**NOTICE:** Use care to prevent kinking the speedometer cable during removal and installation.

### **SPEEDOMETER CABLE CORE**

#### **All Vehicles**

#### **Replacement**

1. Disconnect battery ground cable.
2. Disconnect speedometer cable from speedometer head by reaching up under instrument panel, depressing spring clip and pulling cable from head.
3. Remove old core by pulling it out at end of speedometer cable casing. If old cable core is broken it will be necessary to remove lower piece from transmission end of casing. It is also important to replace both casing and core.
4. Lubricate entire length of cable core with speedometer cable lubricant.
5. To install, reverse Steps 1-3 above.

**NOTICE:** Use care to prevent kinking speedometer cable core during installation.

### **FUEL GAGE**

#### **C-K Series**

#### **Replacement**

1. Perform Steps 1-6 of "Speedometer - Replacement".
2. Remove fuel gage attaching screws and remove the gage.
3. To install, reverse Steps 1-2 above. Check gage operation.

#### **G Models**

#### **Replacement**

1. Remove instrument cluster assembly as previously described.
2. Remove instrument cluster bulb holders, ground screws, nuts and washers retaining laminated circuit to cluster case.

3. Remove 6 screws to release front cover from cluster case.
4. Remove screws retaining fuel gage dial to case.
5. Lift gage away from laminated circuit and rear cluster cover.
6. To install, reverse Steps 1-4 and check operation of fuel gage.  
Observe assembly sequence of nuts, insulator strip, and resistor bar to insure proper reinstallation of gages.

### **TEMPERATURE GAGE**

#### **C-K Series**

#### **Replacement**

1. Perform Steps 1-6 of "Speedometer - Replacement".
2. Remove temperature gage attaching screws and remove the gage.
3. To install, reverse Steps 1 and 2 above and check gage operation.  
Be sure gage studs engage clips holding laminated circuit to back of cluster housing.

#### **G Models**

#### **Replacement**

1. Remove instrument cluster assembly as previously described in this section.
2. Remove terminal nuts and bulb holders retaining laminated circuit to cluster case.
3. Remove attaching screws, cover and gage assembly from cluster housing.
4. Replace entire volt-temp-oil gage assembly.
5. To install, reverse removal procedure and check operation of gage.

### **TEMPERATURE SENDING UNIT**

#### **All Models**

#### **Replacement**

**CAUTION:** Do not remove cap with engine hot, allow vehicle to cool off first.

1. Relieve cooling system pressure by loosening radiator cap to first stop. Tighten cap after pressure is relieved.
2. Disconnect sending unit wiring harness.
3. Remove sending unit from the engine.
4. Install new sending unit and connect electrical harness.
5. Check coolant level and unit operation.  
Coolant must have at least 0°F (-18°C) freeze protection for sending unit to function properly.

### **OIL PRESSURE GAGE**

#### **C-K Series**

#### **Replacement**

1. Perform Steps 1 of Speedometer - Replacement procedure.
2. Remove gage to cluster attaching screws and remove gage.
3. To install, reverse Steps 1-3 above and check gage operation.

**G Models****Replacement**

1. Remove instrument cluster as previously described in this section.
2. Remove and replace volt-temp-oil gage assembly as previously described.

**OIL PRESSURE SENDING UNIT****All Models****Replacement**

1. Disconnect wiring harness connector from sending unit terminal located in block above starter on L-6 engines, at left front of distributor on V-8 (except 454 V-8) or rear left side of block (454 V-8) engines.
2. Remove sending unit using Tool J21757. Replace with new unit and check operation.

**VOLTMETER****C-K Series****Replacement**

1. Perform Steps 1-6 of "Speedometer - Replacement" procedure.
2. Remove gage to instrument panel screws and remove meter.
3. To install, reverse Steps 1 and 2 above and check meter operation.  
Be sure meter studs engage clips holding printed circuit to back of cluster housing.

**G Models****Replacement**

1. Remove instrument cluster assembly as previously described in this section.
2. Remove and replace volt-temp-oil gage assembly as previously described.



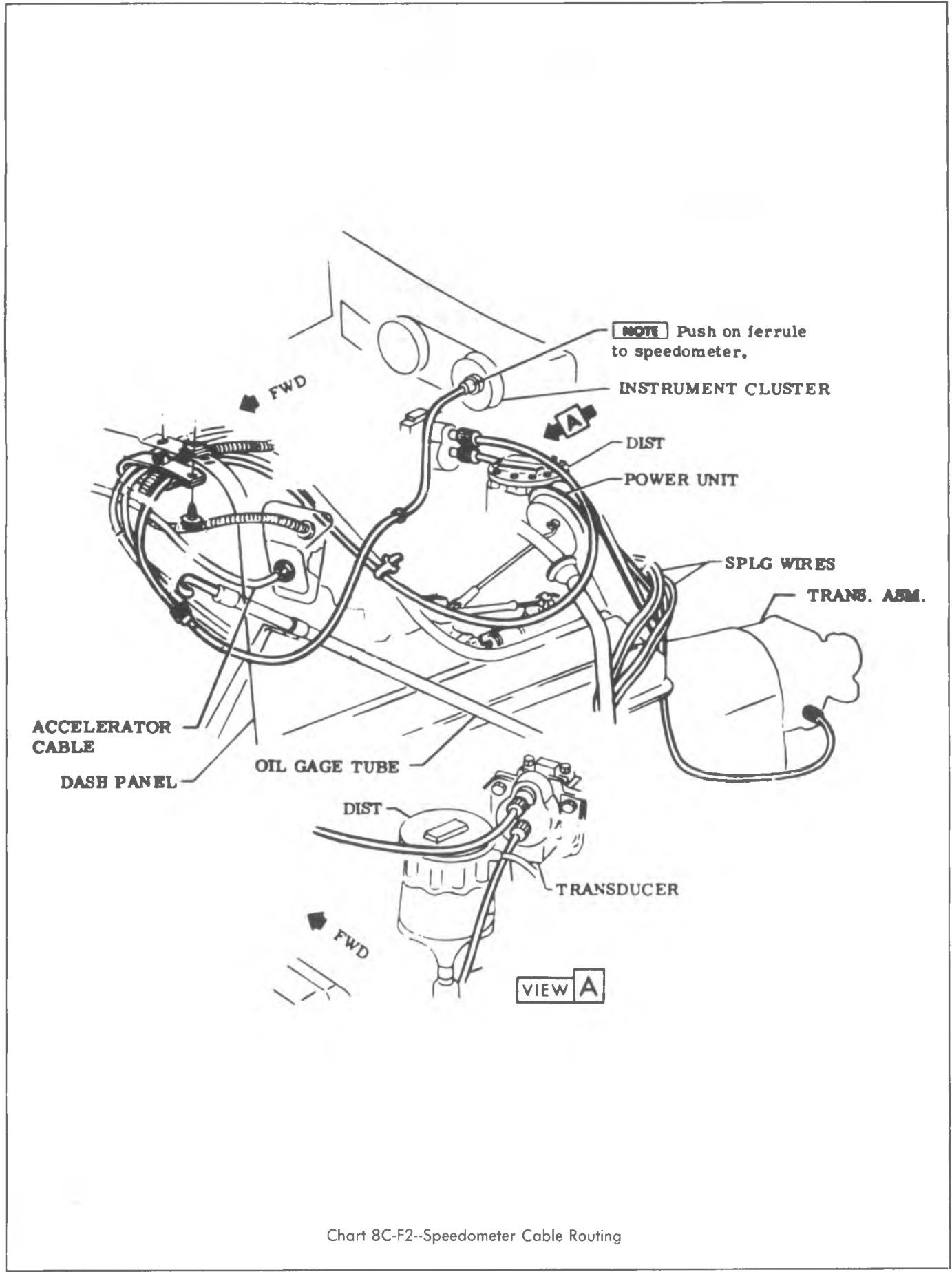

Chart 8C-F2--Speedometer Cable Routing

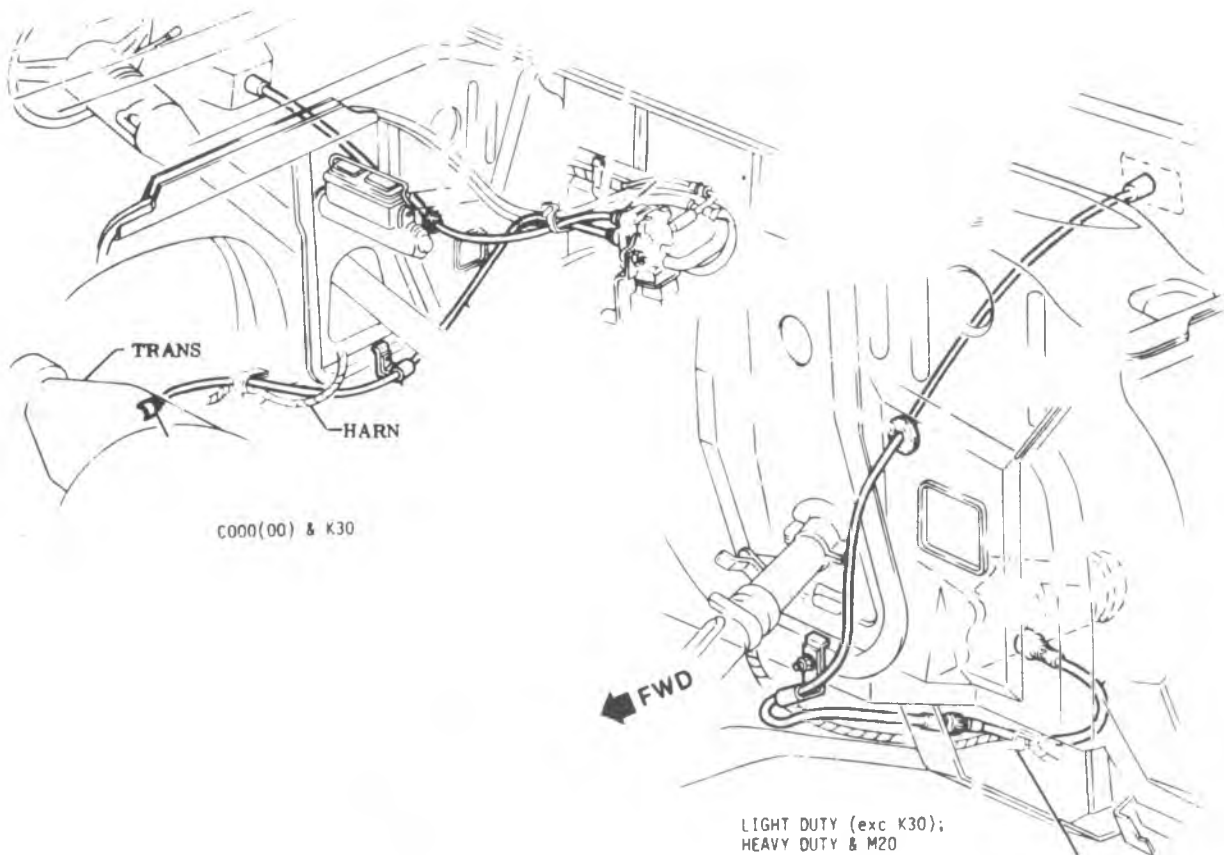
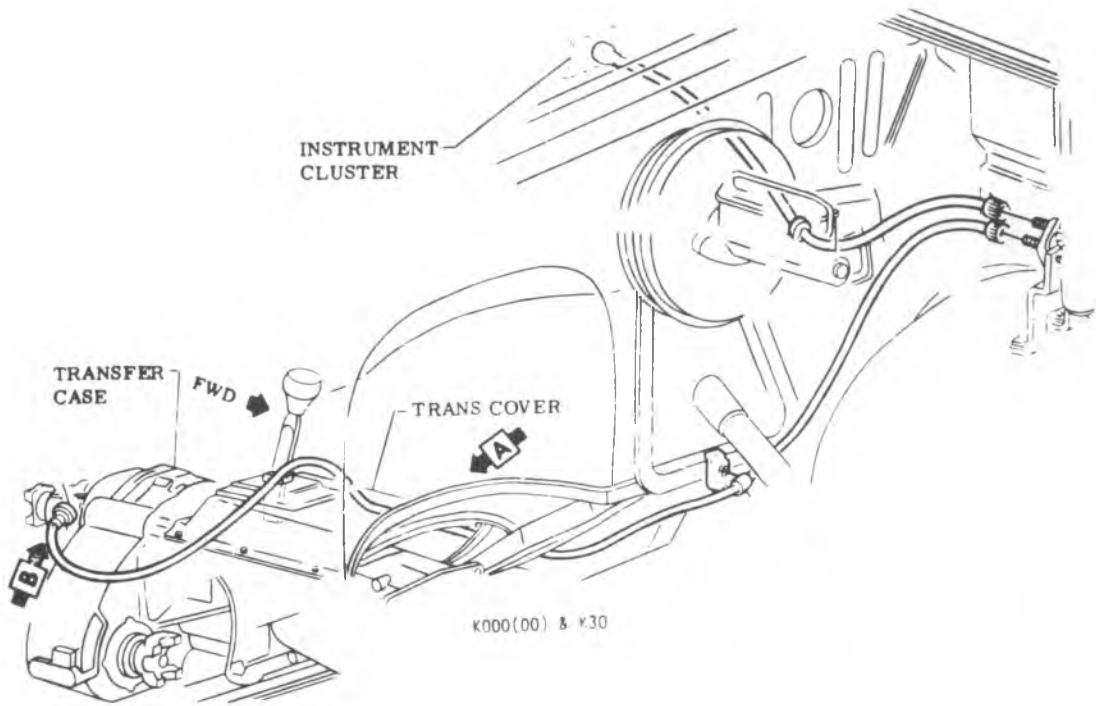

Chart 8C-G2--Speedometer Cable Routing

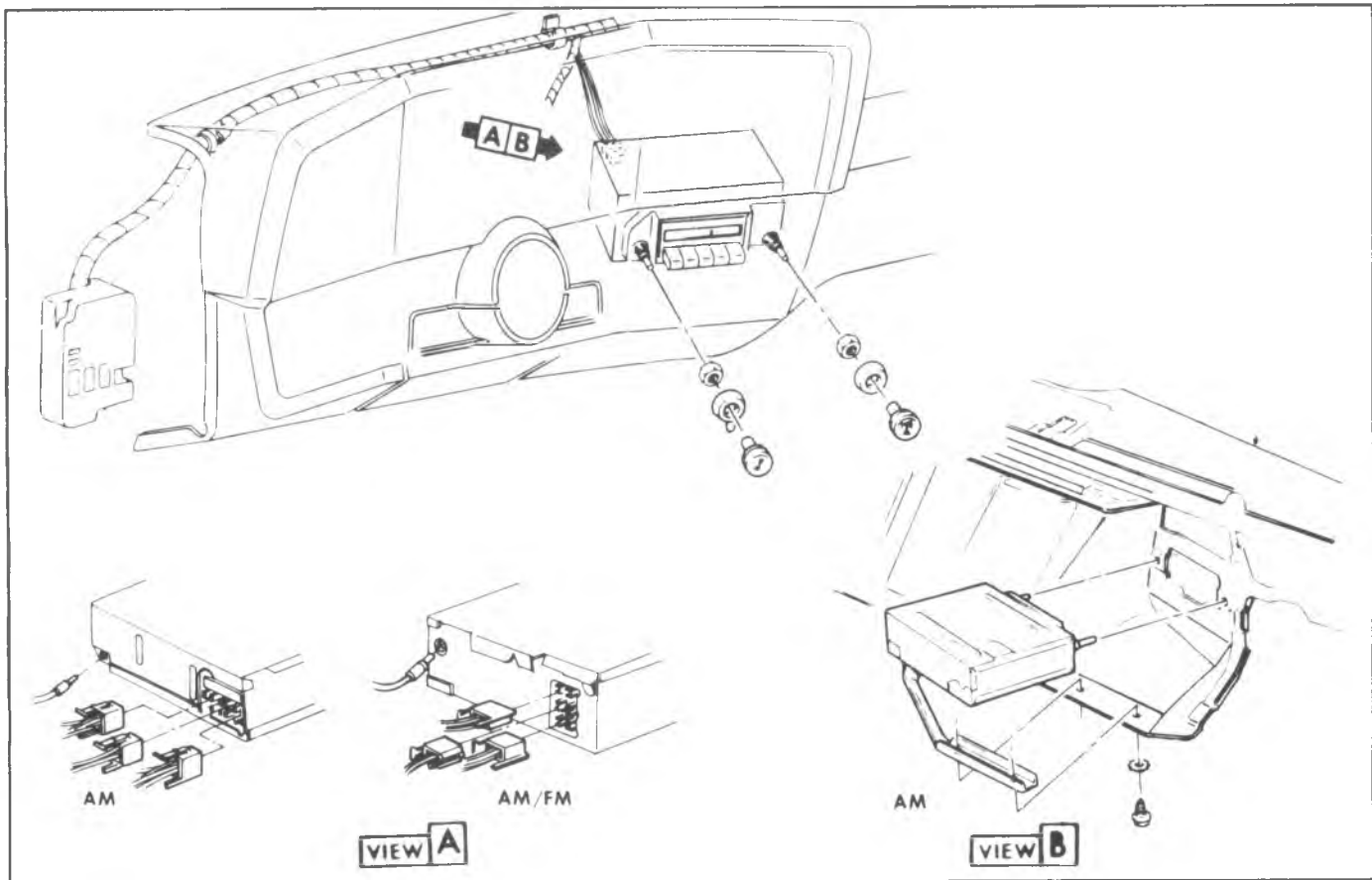

Fig. 8C-5--Radio Receiver (C-K Series)

## RADIO RECEIVER

### REMOVAL AND INSTALLATION

#### C-K Series

##### Replacement (Fig. C-5)

1. Disconnect battery ground cable.
2. Pull off radio control knobs and remove knob bezels. Remove nuts and washers from control shafts using a deep well socket.
3. **AM Radio** -Remove the radio support bracket stud nut and lockwasher.  
**AM/FM Radio** -Remove radio support bracket to instrument panel screws.
4. Lift up on the rear edge of radio. Then push radio forward until control shafts clear instrument panel. Lower control far enough to disconnect electrical harness.
5. Disconnect power feed, speaker and antenna lead wires and remove radio.
6. To install, reverse Steps 1-5 above.

#### G Models

##### Replacement (Fig. 8C-6)

1. Disconnect battery ground cable.
2. Remove engine cover.
3. Remove air cleaner cover and element.

4. Remove radio control knobs and retaining nuts.
5. Remove rear mounting bracket.
6. Push radio forward in vehicle and then lower assembly and disconnect electrical harnesses and antenna lead.
7. Remove radio receiver from vehicle.
8. To install, reverse Steps 1-7 above.
9. Check operation.

**NOTICE: Always attach speaker wiring harness before applying power to the radio to prevent receiver damage.**

#### RADIO DIAL BULB

AM and AM/FM radio dial bulbs can be replaced with the radio in the truck. Tape player radios must be removed from the vehicle for dial bulb replacement.

It is not recommended that CB Radio dial bulb be replaced except by a qualified radio repair service.

##### Replacement (All Models)

#### AM Radio

1. Slide radio dial lens upward, approximately 1/8 inch.
2. Tip bottom edge of lens outward (toward technician) and remove lens.
3. Pull out bulb section and remove bulb.
4. Install new bulb into socket and then reinstall bulb section.
5. Reinstall dial lens.

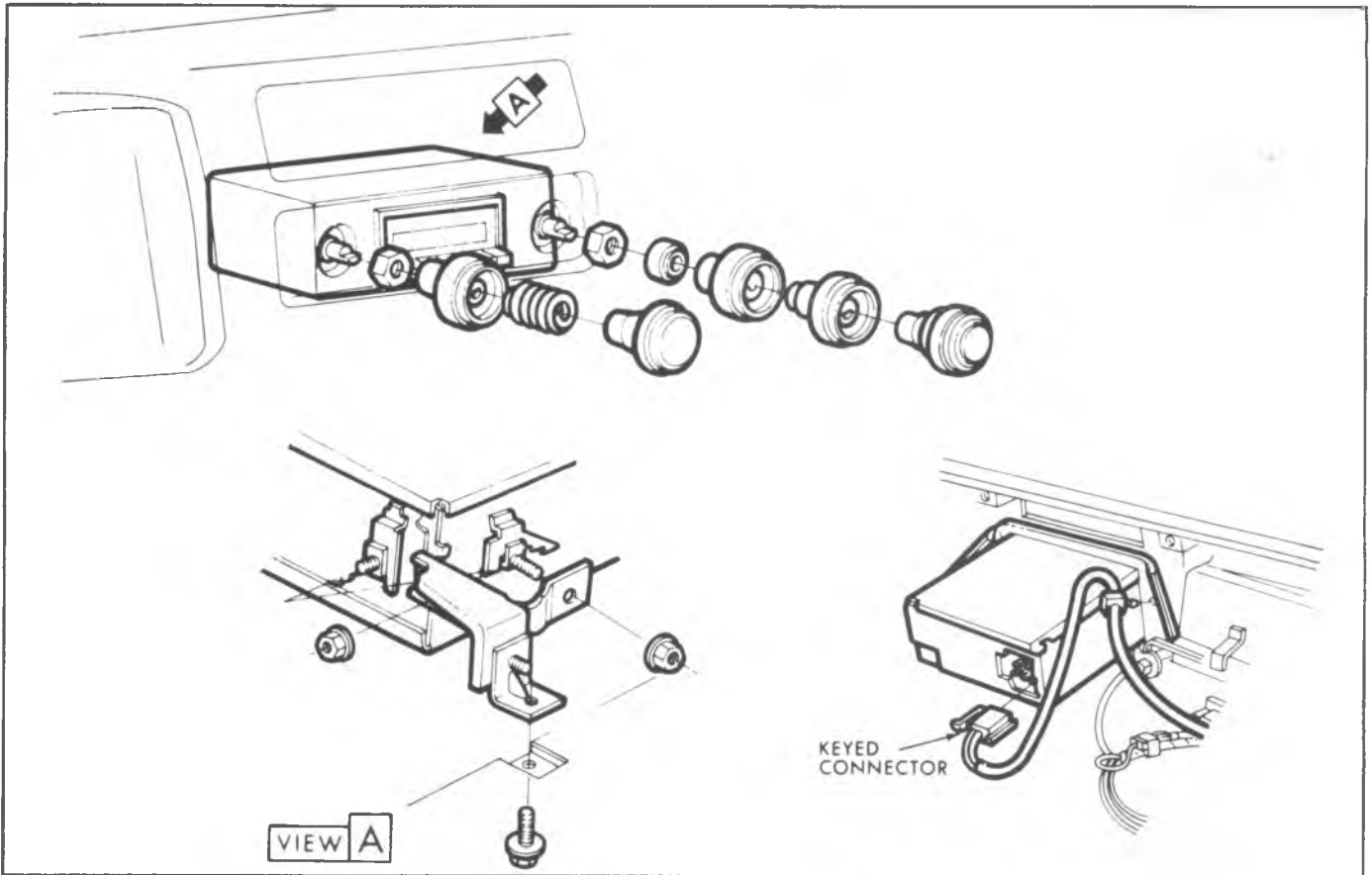

Fig. 8C-6--Radio Receiver Installation--G Models

**AM-FM And Stereo Radio**

1. Slide radio dial lens upward approximately 1/8 inch.
2. Tip bottom edge of lens outward (toward technician) and remove lens.
3. Remove rear dial plate screw. Place dial pointer at 16 and remove plate.
4. Remove bulb.

5. To install, reverse steps 1-4 above.

**Tape Player Radio**

1. Remove radio from vehicle.
2. Remove radio top cover.
3. Remove bulb.
4. To install, reverse steps 1-3 above.

**FRONT SPEAKER**

**C-K Models**

**Replacement (Fig. 8C-7)**

1. Disconnect battery ground cable.
2. Remove instrument cluster bezel upper four screws.
3. Remove instrument panel pad screws and remove pad.
4. Remove speaker to dash panel screws.
5. Lift up on speaker, disconnect speaker wiring harness and then remove speaker.
6. To install, reverse Steps 1-5 above.

**G Models**

**Replacement (Fig. 8C-4)**

**G Models--Left Side**

1. Disconnect battery ground cable.
2. Remove instrument panel bezel.
3. Remove instrument cluster.
4. Remove speaker attaching screws, disconnect wiring harness and remove speaker.
5. To install, reverse Steps 1-4 above.
6. Check operation.

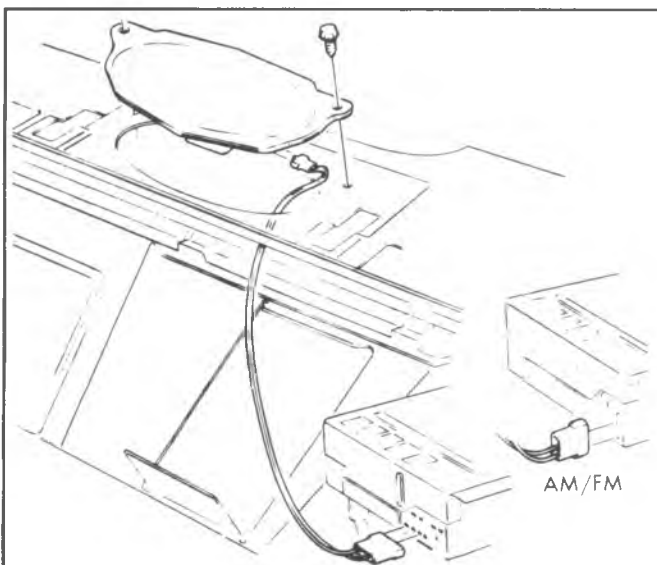

Fig. 8C-7--Radio Front Speaker (C-K Series)

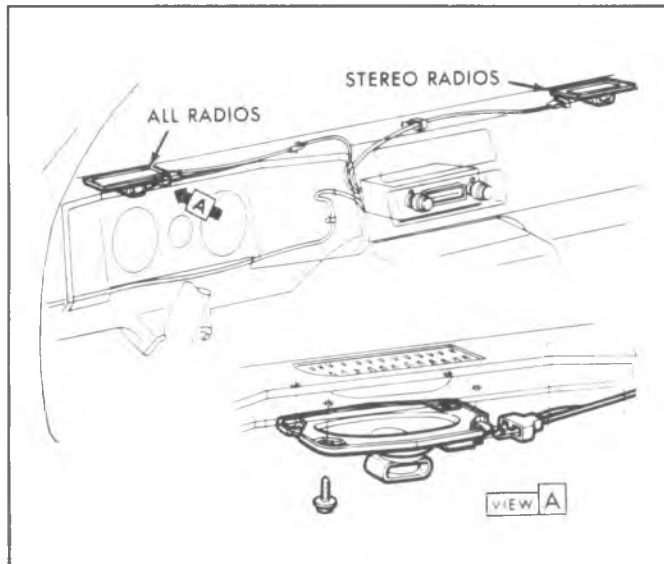

Fig. 8C-8--Speaker Installation--G Series

**G Models--Right Side**

1. Disconnect battery ground cable.
2. Remove engine cover.
3. Remove steering column brace bolts.
4. Remove radio support bracket bolt and instrument panel upper and lower attaching screws.
5. Pull instrument panel assembly rearward to gain access to speaker.
6. Remove speaker attaching screws, disconnect speaker wiring harness and remove speaker.
7. To install, reverse Steps 1-6 above.
8. Check operation.

**REAR SPEAKER**

**C-K Series**

**Replacement (Fig. 8C-9)**

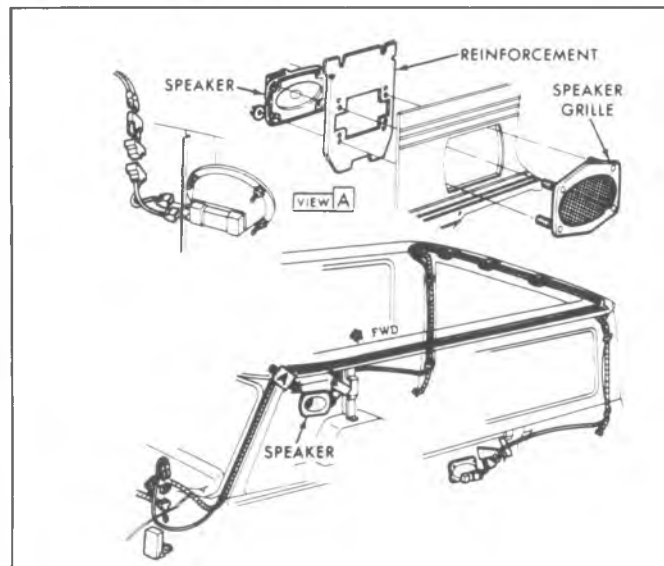

Fig. 8C-11--Rear Speaker (G (06) Truck)

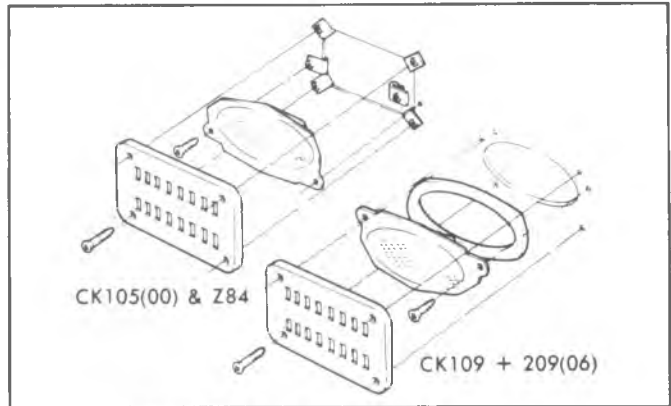

Fig. 8C-9--Rear Speaker (C-K Models)

1. Remove four screws securing speaker grille to trim panel and remove grille.
2. Disconnect electrical connector from speaker.
3. Remove two screws securing speaker to trim panel and remove speaker. On 109 and 209 (06) models, there is a gasket between speaker and trim panel.
4. Install replacement speaker in reverse order of removal.

**G Models**

**Replacement (Figs. 8C-10 and 8C-11)**

1. Remove the four most forward lower screws securing right rear trim panel. Pull trim panel outward slightly for access to speaker.
2. Disconnect electrical connector from speaker.
3. Remove four nuts securing speaker to grille studs and remove speaker.
4. Install replacement speaker in reverse order of removal.

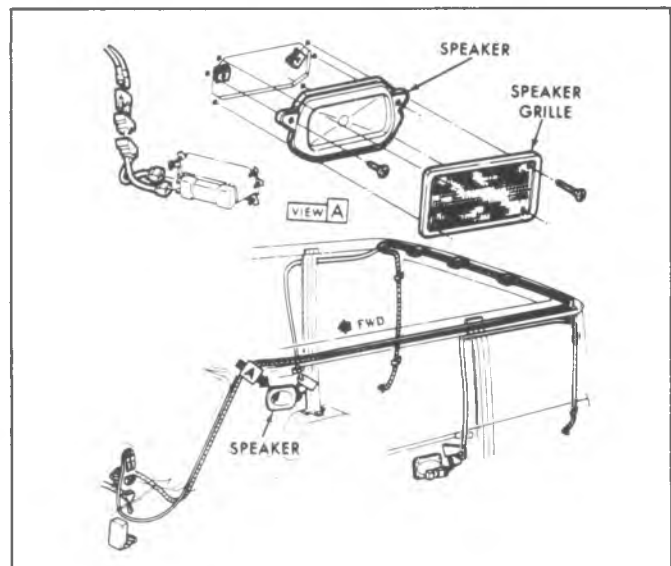

Fig. 8C-10--Rear Speaker (G (05) Truck)

## DIRECTIONAL SIGNAL SWITCH

The directional signal switch is a self-contained unit which incorporates the hazard warning switch and the lane changing signal.

The hazard warning circuit is activated by a push-pull switch which is located on the right side of the steering column, opposite the directional signal lever. The switch knob must be pulled to cancel circuit.

The lane changing circuit is activated by holding the directional signal lever in the first detent position; there is no lock in or cancelling device in this position.

See Section 3B "Steering" for all servicing procedures.

### INSTRUMENT PANEL WIRING HARNESES

Refer to Figs. 8C-12 thru 8C-15.

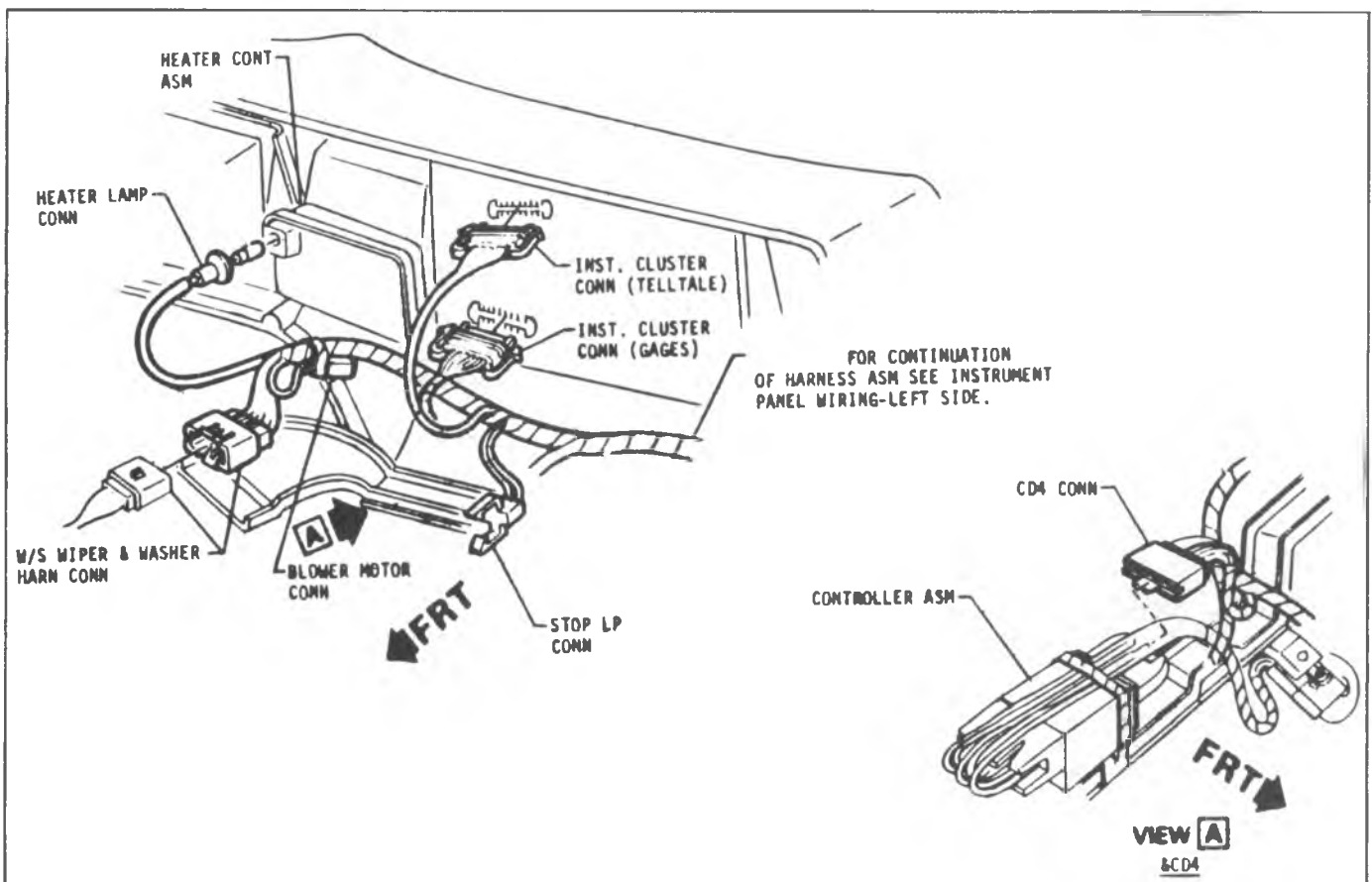

Fig. 8C-12--Instrument Panel Wiring - R.H. - G Models

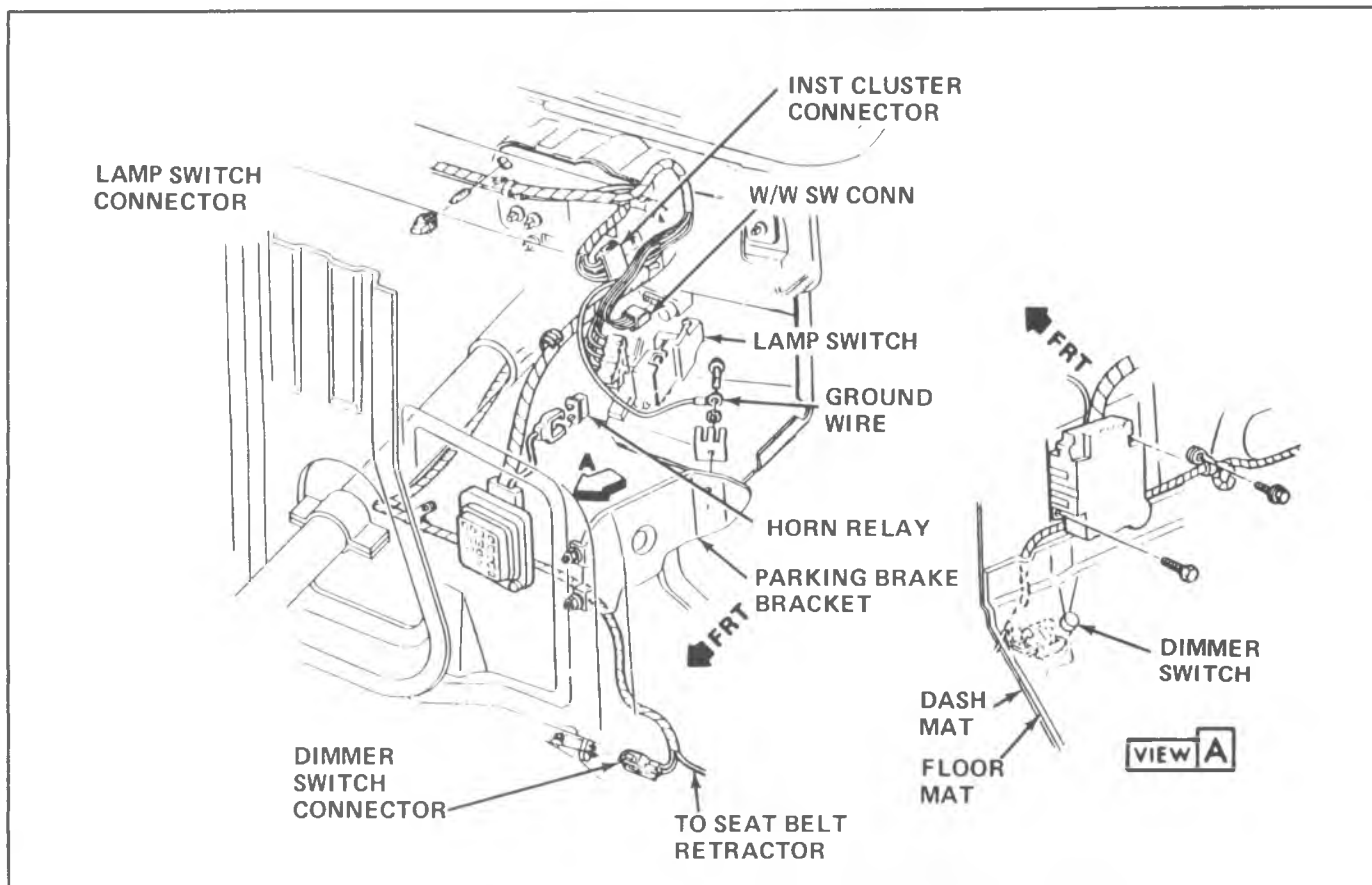

Fig. 8C-13--Instrument Panel Wiring - L.H. - G Models

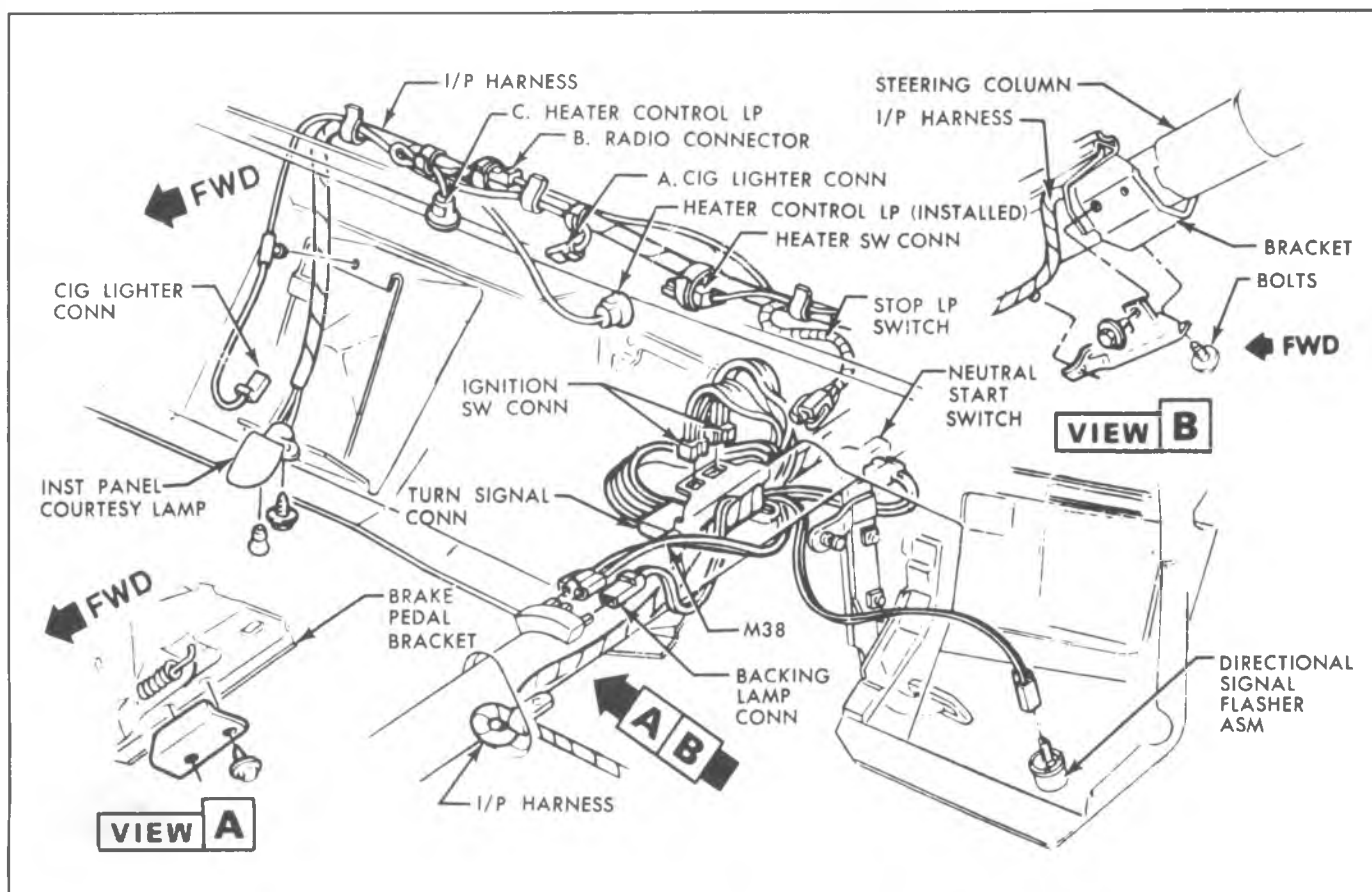

Fig. 8C-14--Instrument Panel Wiring R.H. - CK Models

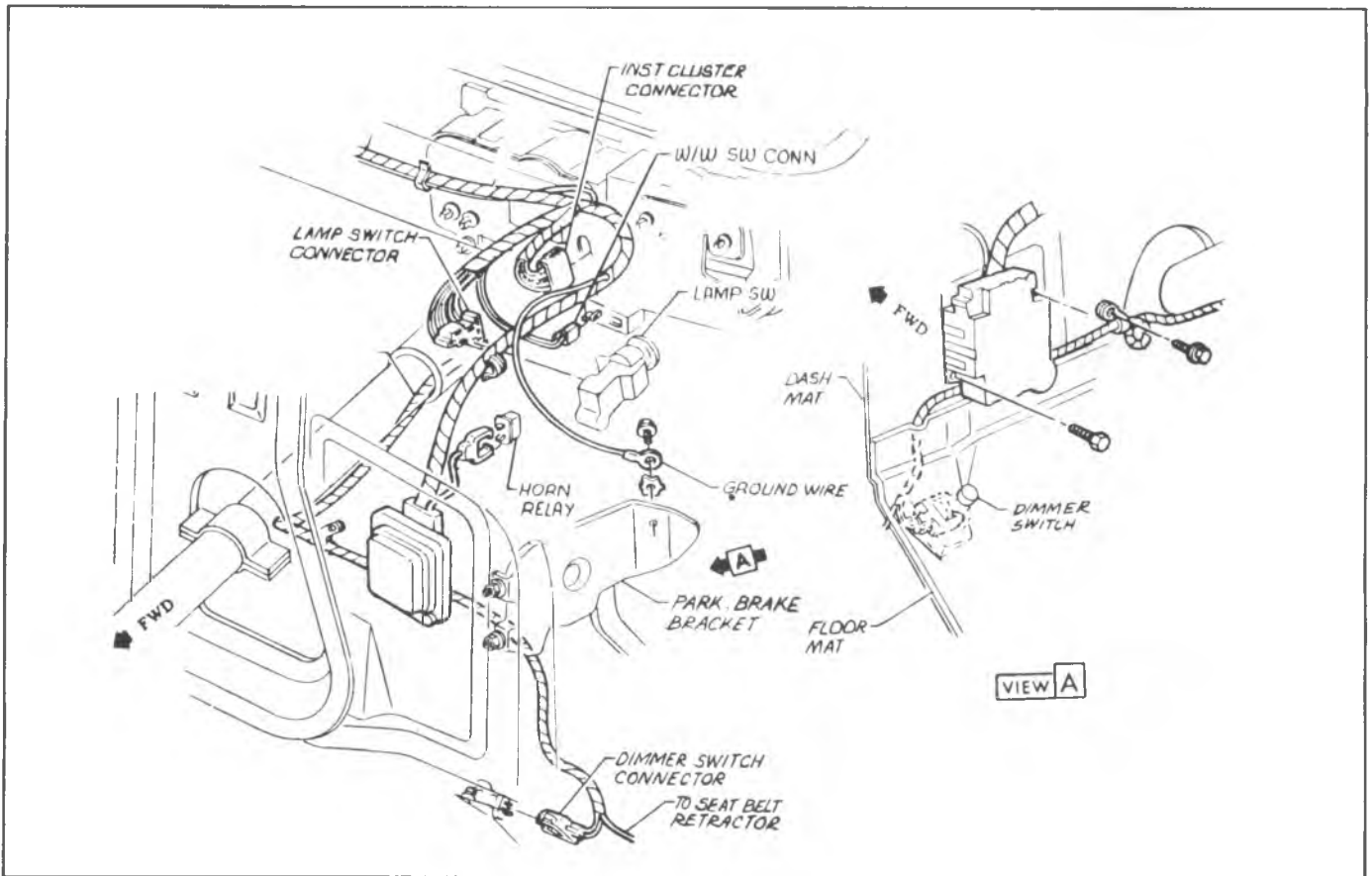

Fig. 8C-15--Instrument Panel Wiring - L.H. - CK Models

## WINDSHIELD WIPER AND WASHER

### C-K-G Series

#### GENERAL DESCRIPTION

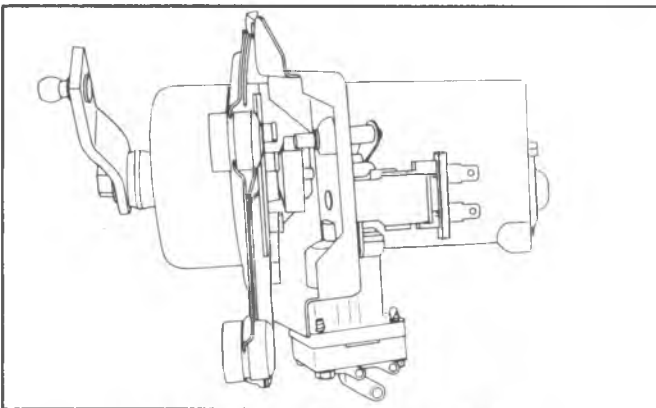

Fig. 8C-16--Wiper Motor Housing

A permanent magnet type wiper is used on CK & G Series. The motor parts-field magnets, armature, drive gear etc. are enclosed in a two piece sheet metal housing. For purposes of explanation the housing halves are referred to as upper and lower housings. The two housings are attached to each other by ten extrusions which are staked over. Figure 8C-16.

As shown in Figure 8C-9, the washer pump parts are assembled on the outside surface of the upper half of the

sheet metal housing. Thus, the washer pump becomes an integral part of the wiper motor assembly.

The wiper motor is protected by an automatic reset type circuit breaker located on the motor brush holder assembly. A fuse located in the fuse block protects the vehicle wiring.

The wiper motor can be operated only when the ignition switch is in the "run" or "accessory" position.

Referring to figure 8C-17 note that there are seven terminals which are numbered.

The function of each terminal is covered in the explanation that follows.

**NOTICE:** Wipers are equipped with locking type connectors for attaching vehicle wiring and care should be used when disconnecting wiring from wiper to avoid damaging the connector or terminals.

As shown in figure 8C-17, the wiper motor has three brushes which are referred to as "common", "Lo speed" and Hi speed. When the ignition switch is "ON", 12 V(positive) circuit is completed to the common brush via no. 1 terminal. The Lo and Hi speed brushes are connected to motor terminals two and three.



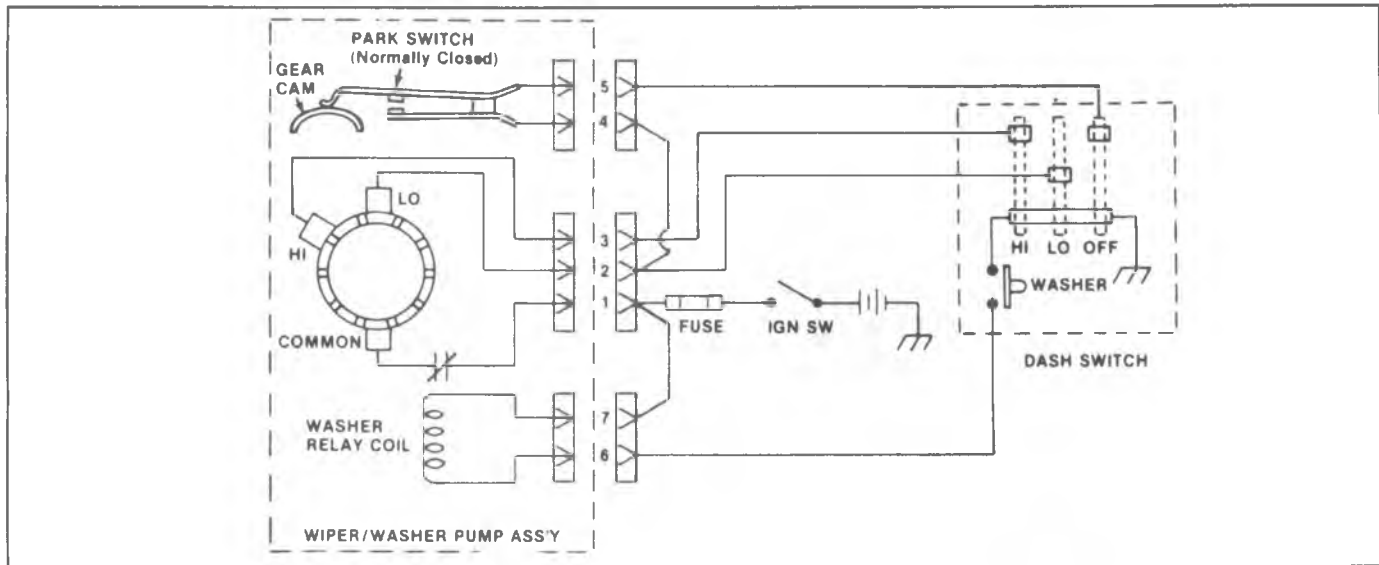

Fig. 8C-17--Wiper Motor Schematic

### LO AND HI SPEED CIRCUITS

Moving the dash switch to the "Lo" or "Hi" speed position completes the respective brush circuit to ground at the dash switch and wiper motor runs at that speed.

### WASHER PUMP OPERATION

The washer pump is an integral part of the wiper motor and cannot be replaced as a separate assembly as was possible with previous motors.

### SHUTTING OFF THE WIPER

This explanation covers that portion of wiper operation when the owner first turns the wiper "off" at the dash switch and the wiper blades have not reached their normal park position, (approximately 1 1/2-2" above the lower windshield molding).

In order to have the blades stop in their normal park position and the wiper motor shut off properly, the motor operates in "Lo" speed. This is accomplished as follows: with the dash switch in the "OFF" position, the Lo speed brush circuit is completed to ground at the dash switch through a park switch located in the gear housing (Terminals 4 and 5). The park switch contacts are normally closed and this permits the wiper to continue to run.

When the blades reach their park position, a cam on the gear opens the normally closed park switch contacts shutting off the wiper.

### WASHER PUMP CIRCUIT

Actuating the washer portion of the dash switch completes the washer pump magnet coil circuit to ground and mechanically moves the wiper motor switch to the Lo speed position. This dual function starts the wiper motor and washer operation simultaneously. When the wash cycle (10 squirts at full pressure) is completed, the wiper will continue to run until the owner returns the switch to the "off" position.

### WASHER PUMP OPERATION

#### Pumping Mechanism

The basic pump consists of a spring loaded piston enclosed in a plastic cylinder housing. Attached to the piston and extending out of cylinder housing is an actuator plate. Attached to the end of the cylinder housing is a valve assembly consisting of two exhaust check valves and one intake check valve. Figure 8C-18.

Note the cam follower pin that extends through an elongated opening in the piston actuator plate. When the wiper motor is running, a 4 lobe cam, which is part of the wiper gear, moves the cam follower back and forth.

#### Pump Idling (No Pumping Action)

Refer to Fig. 8C-19 and note that a tang on the piston actuator plate is resting against a ramp on the lower surface of the ratchet gear. This, in effect, holds the piston actuator plate in a lock-out position. With actuator plate in this position and the wiper running, the cam-follower pin merely moves back and forth in the elongated slot of the piston actuator plate and no pumping action can occur.

The ratchet gear, which, if rotated, would move the ramp away from the tang of the actuator plate releasing the pump action, is prevented from rotating as follows: The relay assembly, consisting of a coil and armature, is constructed in such a way that the ratchet gear pawl extends through an opening in the relay armature (Fig. 8C-19), preventing it from engaging the ratchet gear teeth.

#### Starting the Pump

Actuating the washer button to obtain windshield washer pump operation starts the wiper motor and energizes the relay. When relay is energized, the relay armature is pulled toward the coil, allowing the ratchet gear pawl to drop out of the relay armature opening and engage the teeth of the ratchet gear.

The ratchet pawl, which is actuated by the same cam-follower pin that moves the piston actuating plate, begins to rotate the ratchet gear. Rotating the ratchet gear one tooth moves the ratchet wheel ramp away from the tang of the piston actuating plate (Fig. 8C-20), permitting the

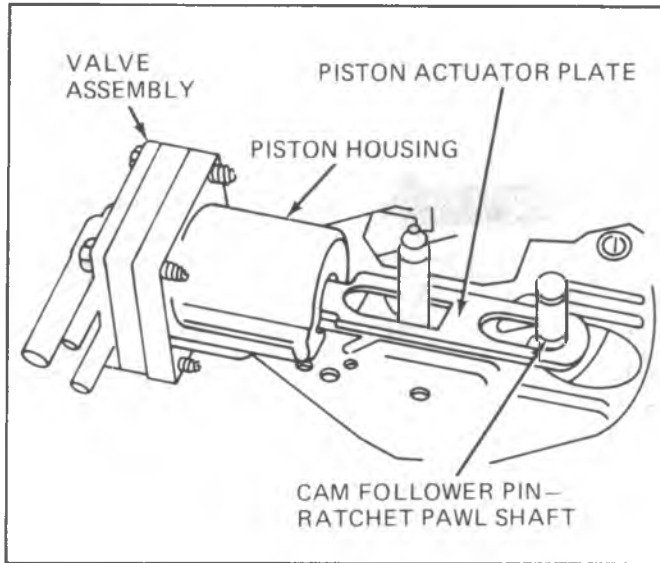

Fig. 8C-18--Washer Valve Assembly

piston spring to expand which in turn forces the piston toward the valve assembly resulting in the first exhaust stroke. This sequence then repeats through the remaining cycles.

#### Intake Stroke

When the cam-follower moves in the direction indicated by the arrow in Fig. 8C-21, the cam-follower pin, which extends through the piston actuating plate, pulls the actuator plate away from the valve assembly compressing the piston spring. As the piston moves away from the valve assembly, a vacuum is created in the cylinder which opens the intake valve, drawing washer solution into the cylinder (Fig. 8C-21).

#### Exhaust Stroke

As the 4-lobe cam continues to rotate, the cam follower moves in the opposite direction described in the intake

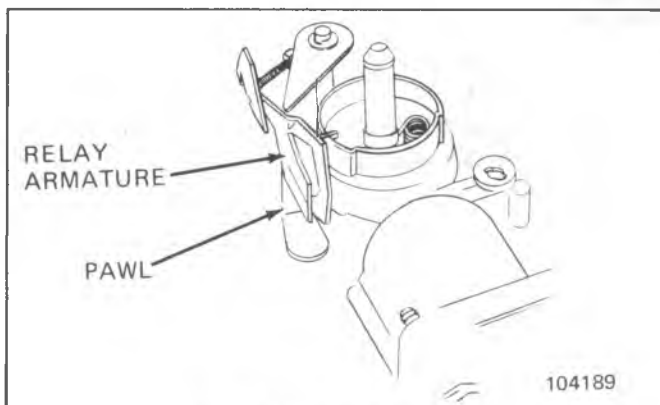

Fig. 8C-20--Relay Armature

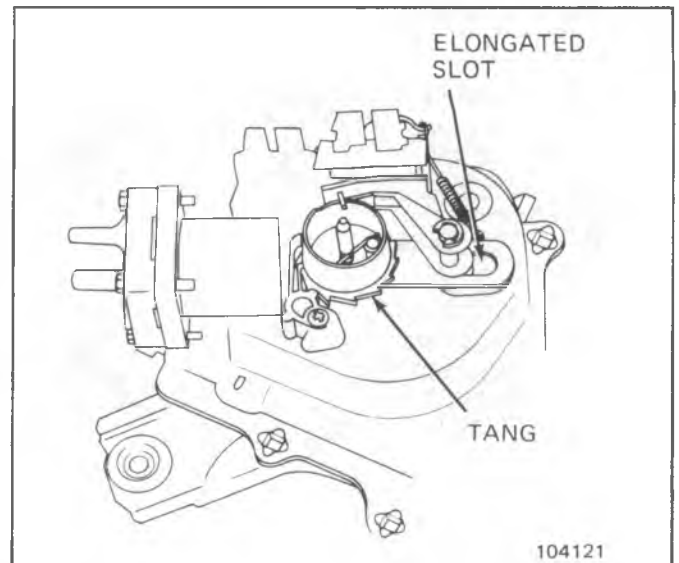

Fig. 8C-19--Ratchet Gear Pawl

stroke. This permits the piston spring to expand which in turn pushes the piston toward the valve assembly creating pressure between the piston and valve assembly. This pressure "build-up" forces the two exhaust valves open compelling the washer solution to flow to the nozzles. See Fig. 8C-21.

For purposes of explanation, only one exhaust valve opening is shown in Fig. 8C-21.

The intake and exhaust stroke cycle will occur four times for each revolution of the wiper drive gear while the washer pump is operating.

#### Stopping the Pump (Completion of the Wash Cycle)

The pumping operation is terminated automatically when the ratchet gear has rotated a full 360° and the 12th cycle is completed. This is accomplished as follows.

As the ratchet gear approaches the completion of its 360° travel, two functions occur simultaneously:

1. A leg on the relay armature rides up a ramp located on the outer surface of the ratchet gear. When the leg reaches the top of the ramp, it moves over the top edge of the ratchet gear. This action allows the ratchet gear pawl to re-enter the armature opening preventing further rotation of the ratchet gear until the next time the relay coil is energized from the washer button. (Refer to Fig. 8C-21 for position of armature leg while pump is idling.)
2. The tang on the piston actuating plate is resting once more against the ramp on the lower side of the ratchet gear (Fig. 8C-18).

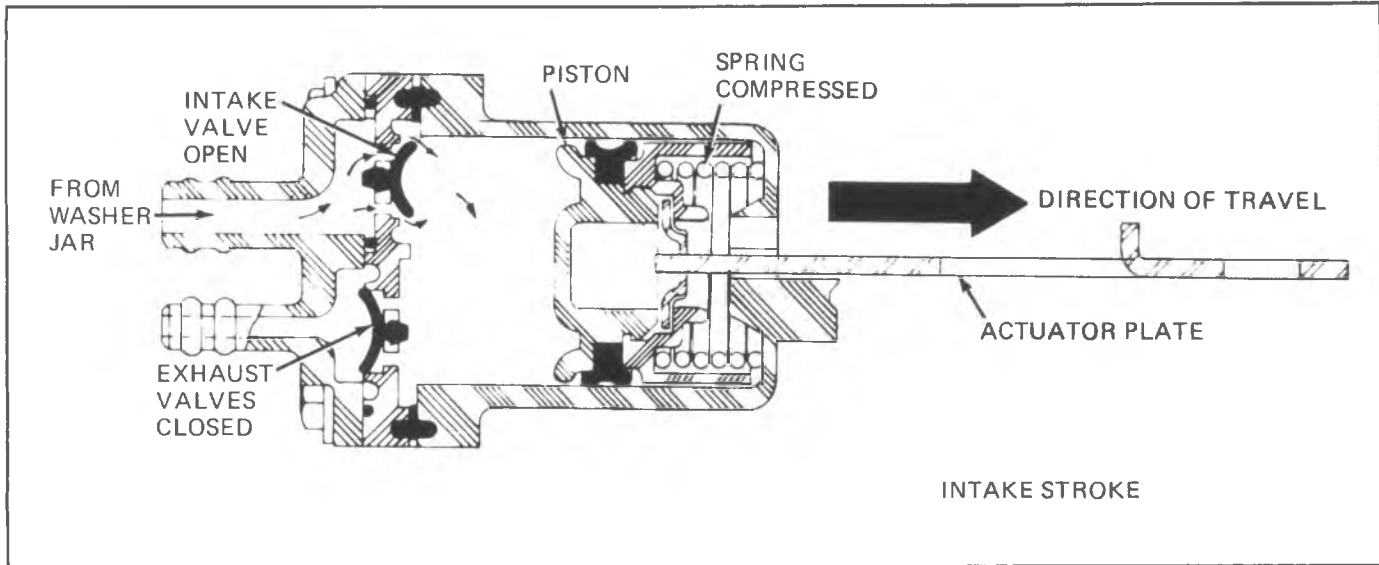

Fig. 8C-21--Pump Operation

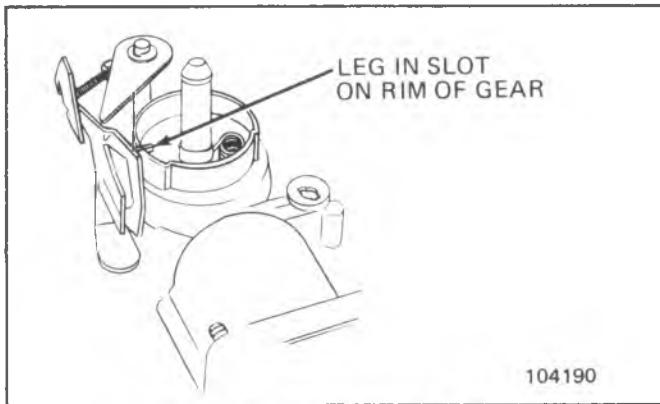

Fig. 8C-22--Armature Leg Position

## DIAGNOSIS

### WIPER - ON VEHICLE

Troubleshooting with wiper installed on the vehicle consists of two basic steps: (A) Preliminary inspection and (B) Operating wiper independent of vehicle wiring and dash switch.

#### Preliminary Inspection Procedure

A. Preliminary Inspection - Check the following items:

1. Body wiring securely connected to wiper unit and dash switch.
2. Wiper ground connection to vehicle chassis.
3. Dash switch is mounted securely.
4. Fuse.

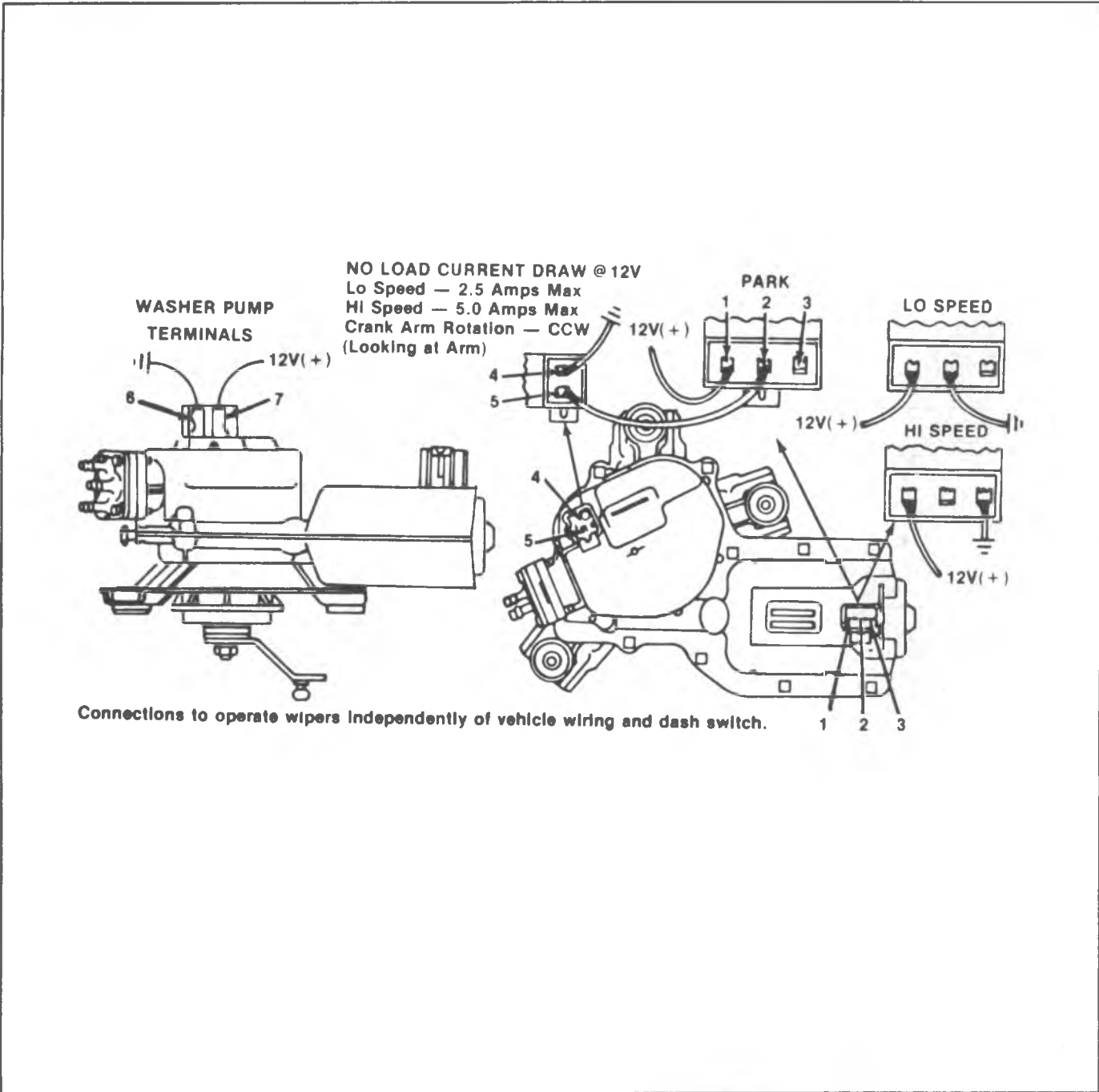
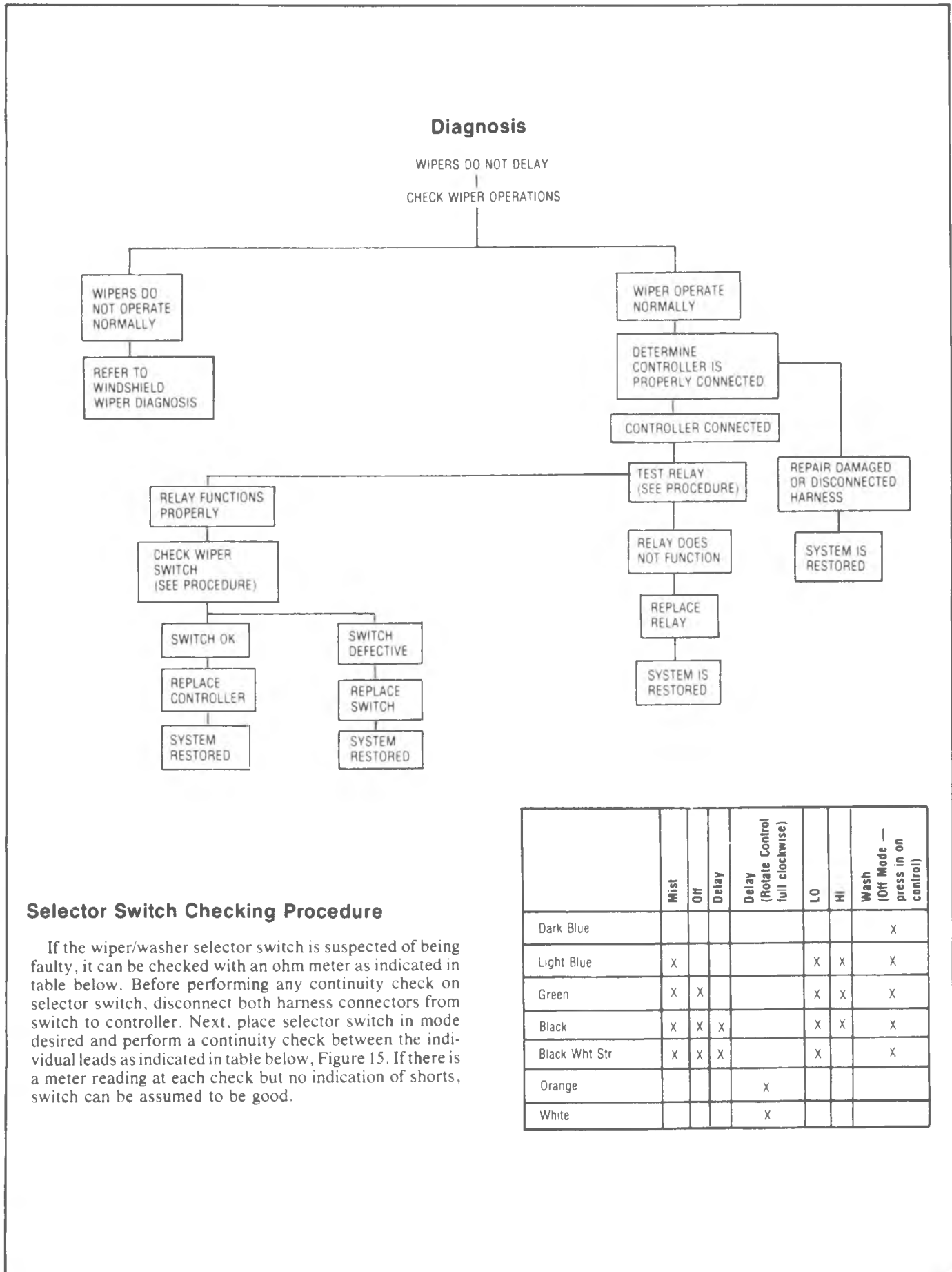

Fig. 8C-23--Wiper Motor Diagnosis Diagram



### Selector Switch Checking Procedure

If the wiper/washer selector switch is suspected of being faulty, it can be checked with an ohm meter as indicated in table below. Before performing any continuity check on selector switch, disconnect both harness connectors from switch to controller. Next, place selector switch in mode desired and perform a continuity check between the individual leads as indicated in table below, Figure 15. If there is a meter reading at each check but no indication of shorts, switch can be assumed to be good.

|               | Mist | Off | Delay | Delay<br>(Rotate Control<br>full clockwise) | LO | HI | Wash<br>(Off Mode —<br>press in on<br>control) |
|---------------|------|-----|-------|---|----|----|--|
| Dark Blue     |      |     |       |   |    |    | X  |
| Light Blue    | X    |     |       |   | X  | X  | X  |
| Green         | X    | X   |       |   | X  | X  | X  |
| Black         | X    | X   | X     |   | X  | X  | X  |
| Black Wht Str | X    | X   | X     |   | X  |    | X  |
| Orange        |      |     |       | X   |    |    |  |
| White         |      |     |       | X   |    |    |  |

## DIAGNOSIS CHART

| SYMPTOM   | PROCEDURE NO. |
|---|---------------|
| 1) Wiper Inoperative - Both Lo and Hi   | 1             |
| 2) Lo speed only - inoperative in Hi  | 2             |
| 3) Hi speed only - inoperative in Lo  | 3             |
| 4) One speed - same in both Lo and Hi   | 4             |
| 5) Blades stop at random positions when wiper is turned off. (Do Not Return to Park Position) | 5             |
| 6) Wiper will not shut off  | 6             |
| 7) Intermittent operation   | 7             |
| 8) Wiper motor runs but blades don't move   | 8             |
| 9) Washer pump inoperative  | 9             |
| 10) Washer won't shut off   | 10            |

### PROCEDURE I (Wiper Inoperative)

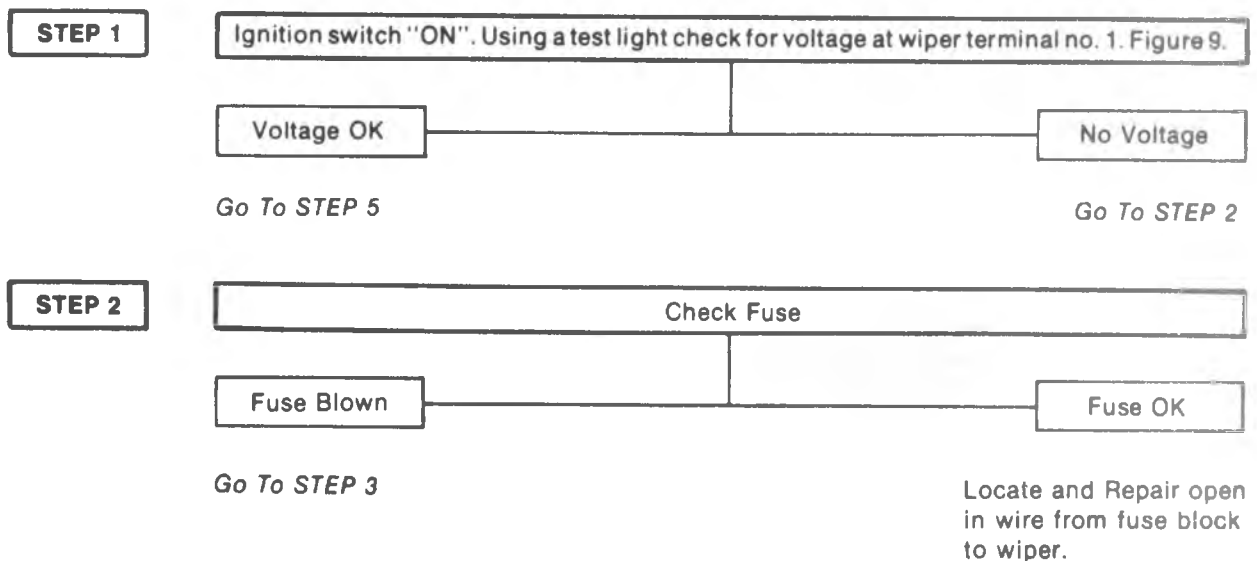

**Procedure 1 (cont.)**

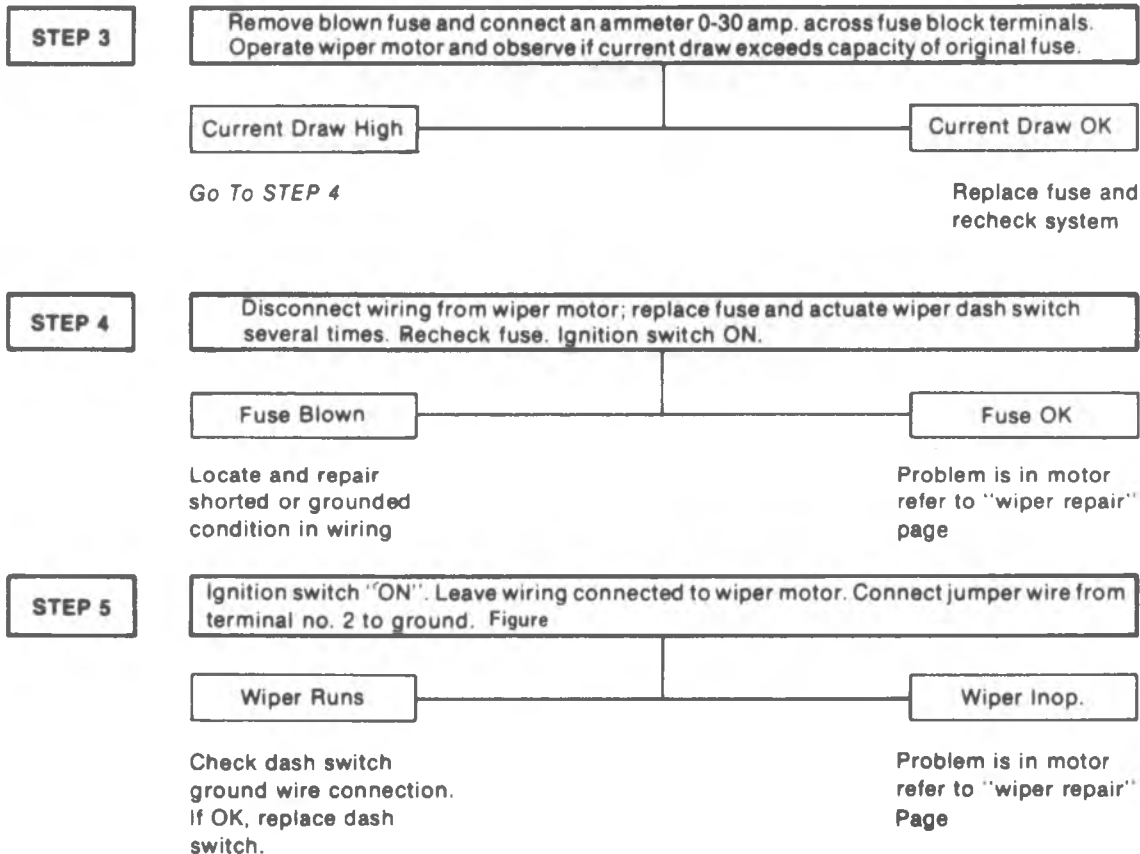

**PROCEDURE 2 (Lo Speed Only) (Inop in Hi)**

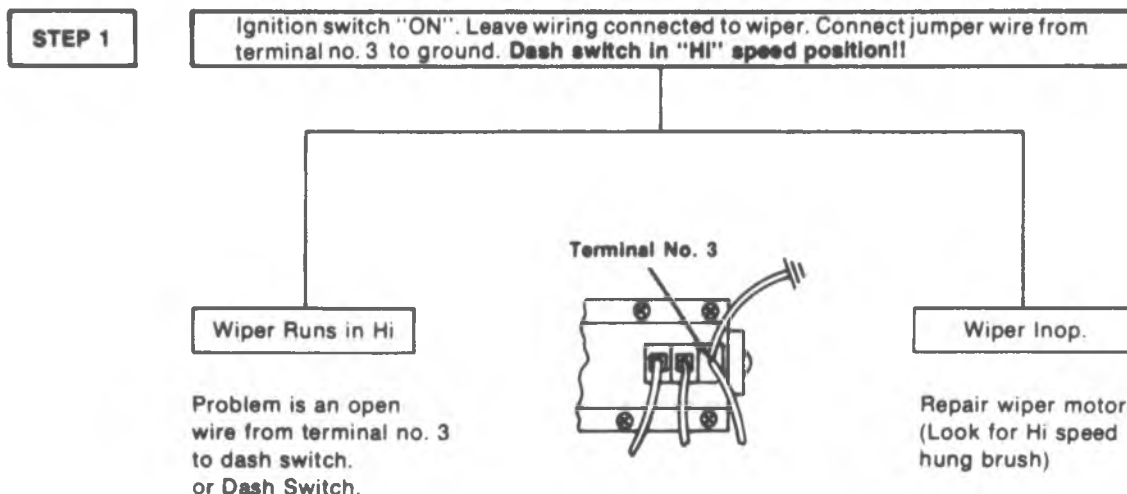

### PROCEDURE 3 ("Hi" Speed Only) (Inop in Lo)

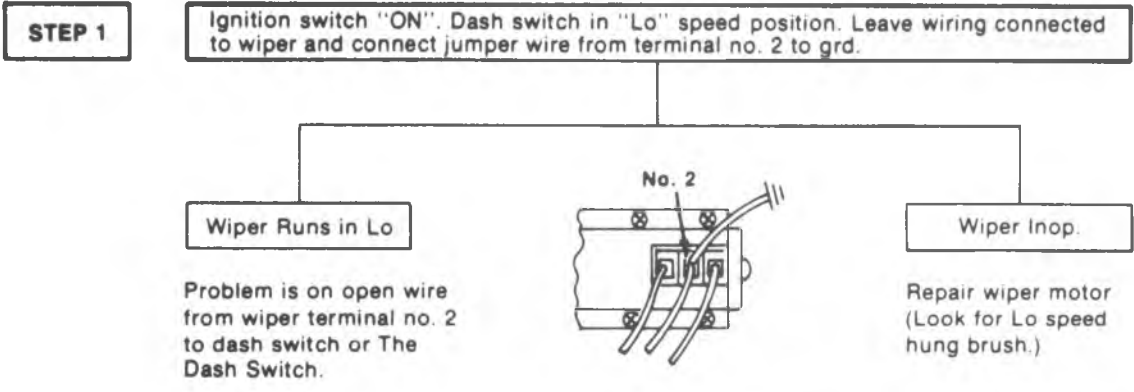

### PROCEDURE 4 (One speed - same in both Lo and Hi).

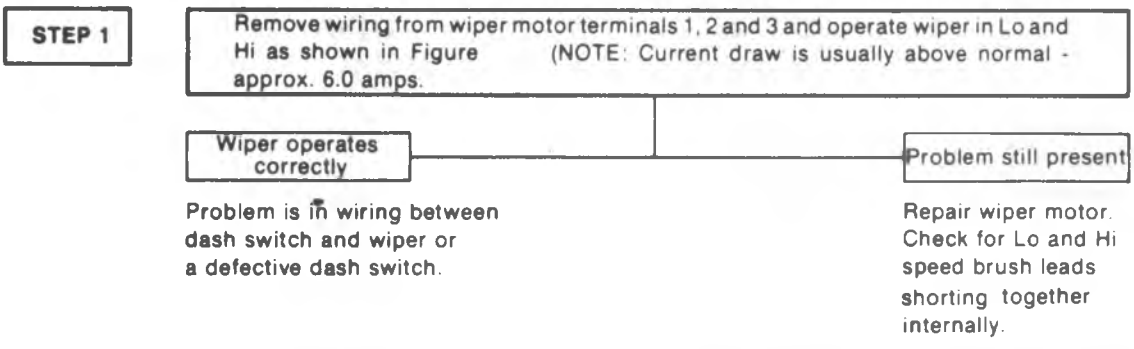

### PROCEDURE 5 (Wiper shuts off but blades don't return to park position)

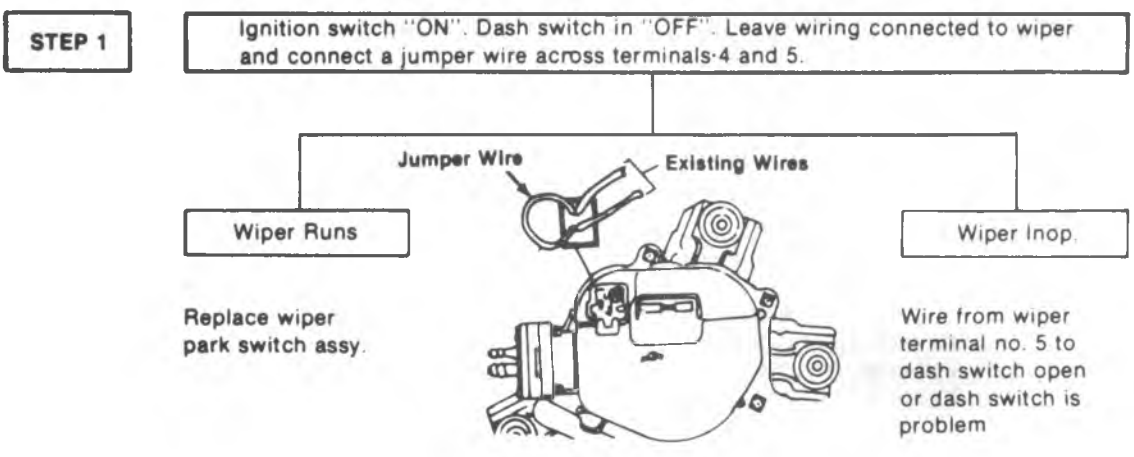



### PROCEDURE 6 (Wiper will not shut off)

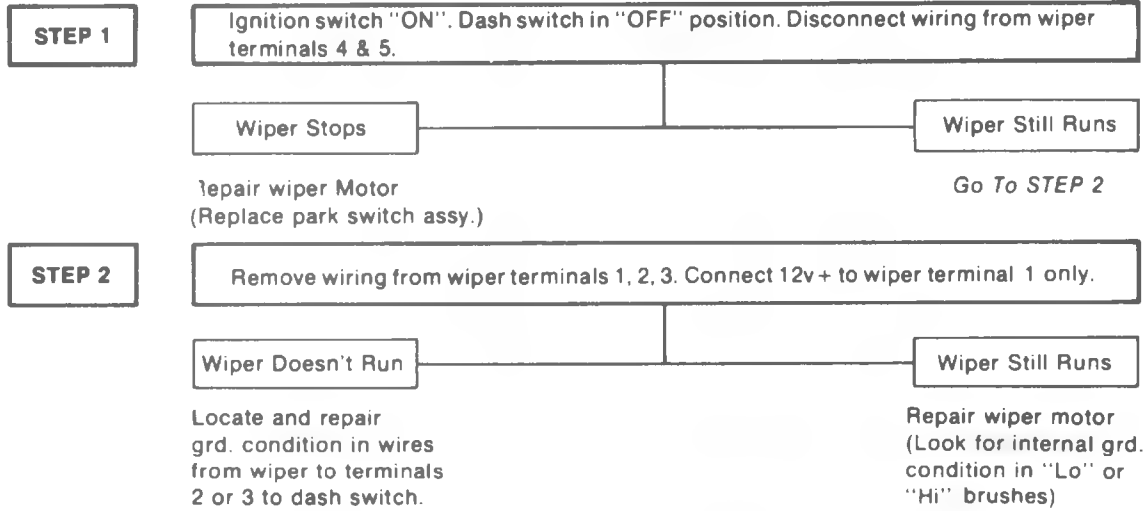

### PROCEDURE 7 (Intermittent Operation) (Wiper has both speeds)

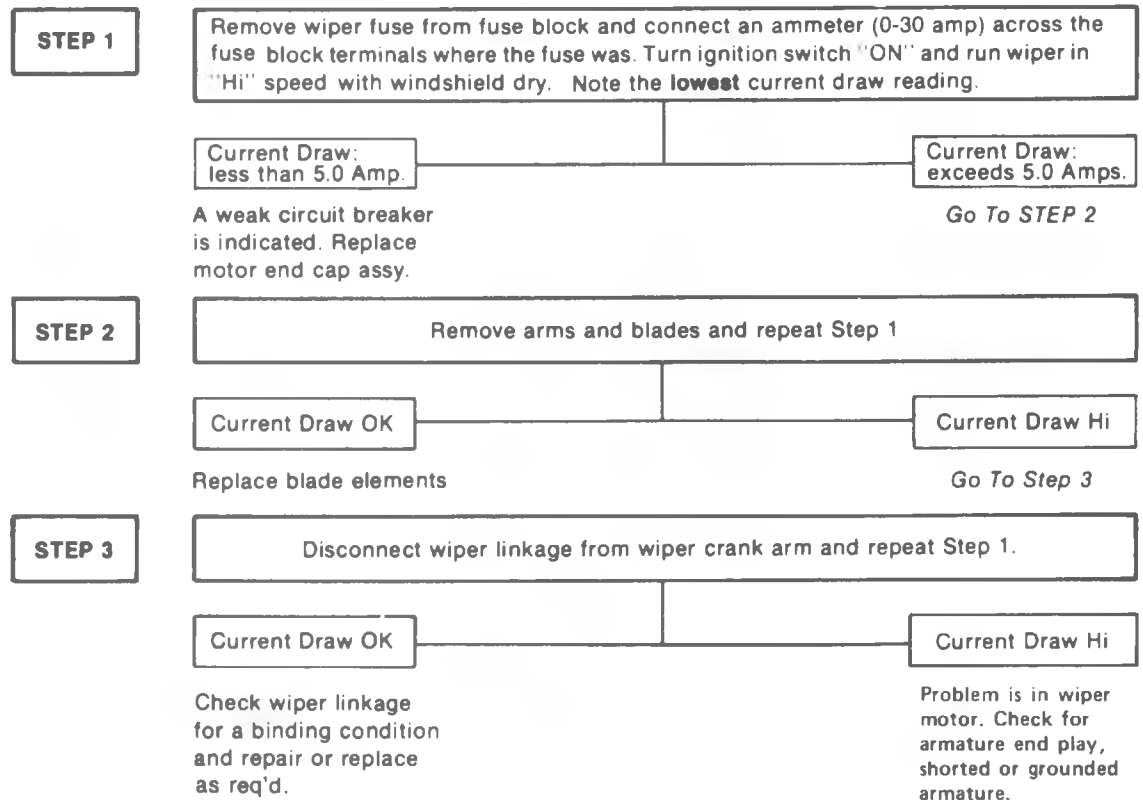

### PROCEDURE 8 (Wiper Runs But Blades Don't Move)

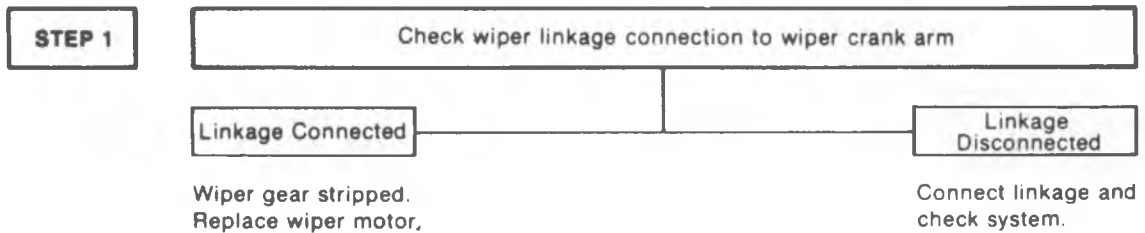

### PROCEDURE 9 (Washer Pump Inoperative)

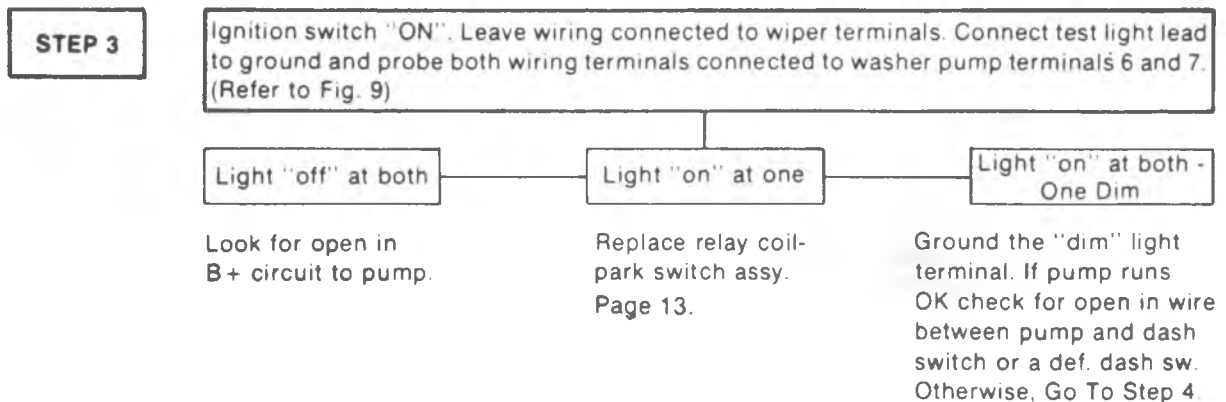
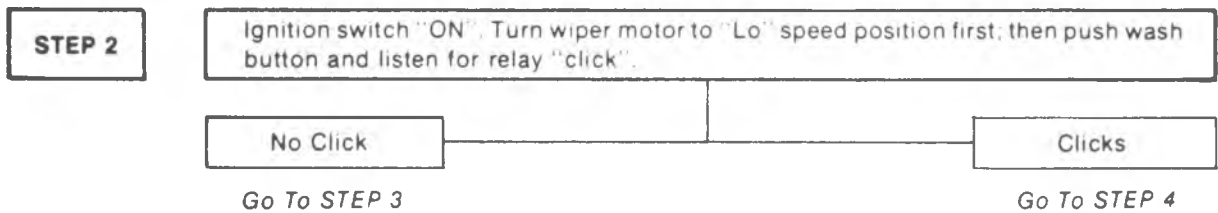
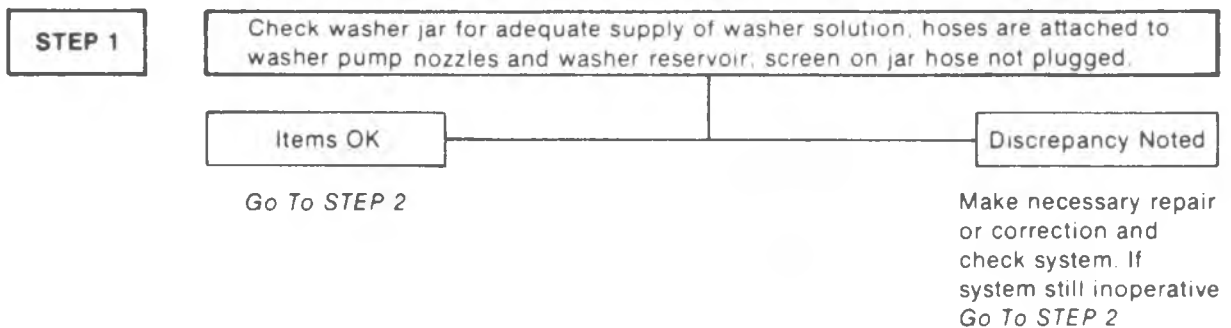

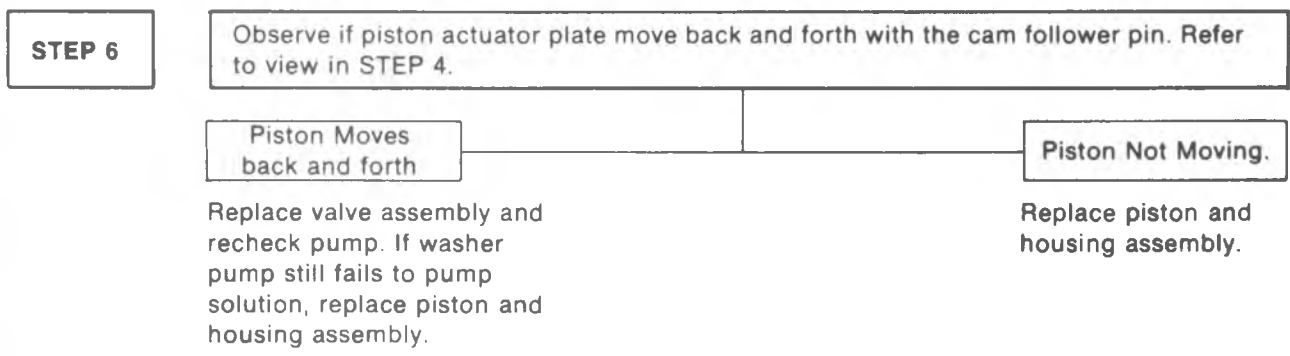
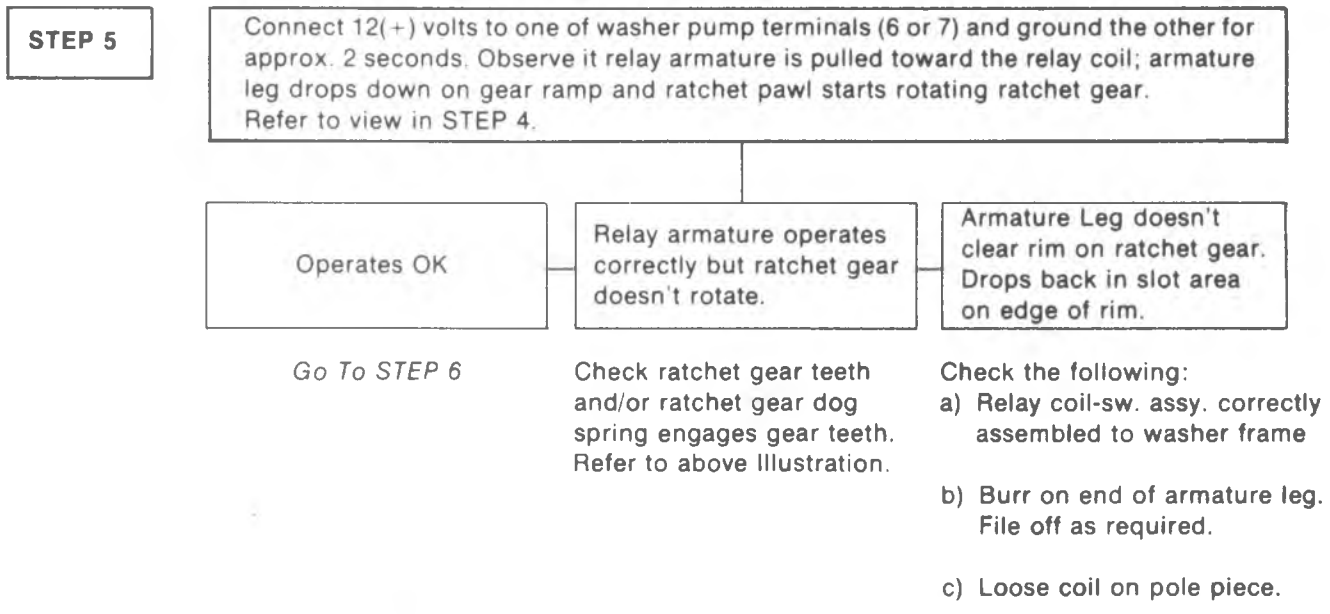
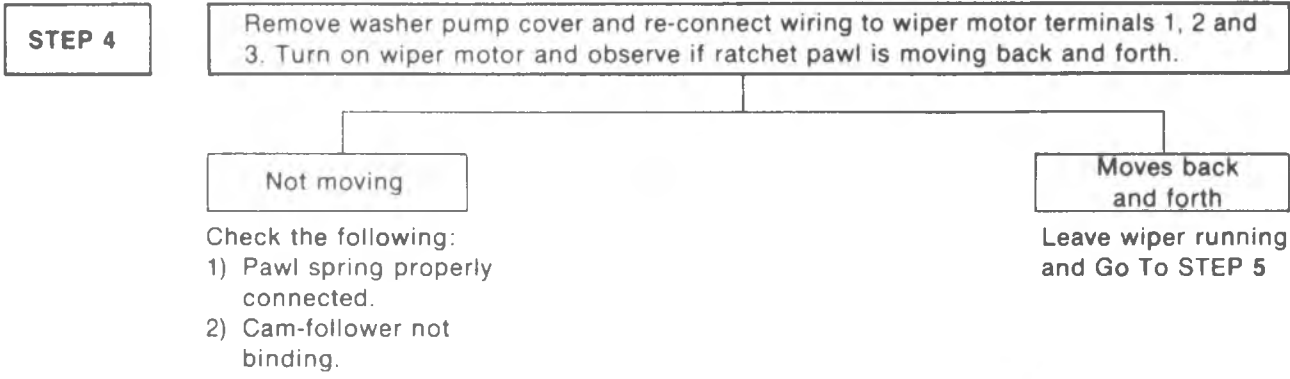

## PROCEDURE 10 (Washer Pumps Continuously)

### STEP 1

Have wiper running and disconnect wiring from washer pump terminals 6 and 7. Observe if pump completes wash cycle and stops pumping.

Pump stops

Pump keeps running

Check for grounded wire between pump terminal and dash switch or a defective dash sw.

Go To STEP 2

### STEP 2

Disconnect wiring from wiper unit; remove washer pump cover and re-connect wiring to wiper-washer. Turn on wiper and check the following items.

- a) Ratchet gear dog spring engaging ratchet gear teeth.
- b) Weak spring tooth on ratchet gear.
- c) Ratchet gear tooth damaged
- d) Cam-follower damaged.

Replace item(s) as required.

## DELAY WIPER SYSTEM OPERATION AND DIAGNOSIS

Light duty trucks use a separate control assembly to operate the windshield wipers over a variable delay of 1 to 20 seconds. The control assembly plugs into the selector switch at two different connectors. One of these connectors has a piggy-back connector that connects to the regular wiper harness. There is also a lead from the control that plugs into the accessory cavity of the fuse panel. Moving the control knob of the selector switch to the extreme left position and holding it there, will result in a MIST mode. The mist mode feature provides momentary low speed wiper operation as long as the control knob is held in position. This position is spring loaded and will only remain activated as long as the knob is held in position. Upon releasing the control knob, it will automatically return to OFF position. By positioning the control knob in the first detent right of OFF, the selector switch is in the DELAY mode. Rotation of the control knob while in the delay mode regulates the delay period between the time it takes the wiper to make one sweep and momentarily stop.

Shifting the control knob right to next detent position will put the wipers in a LOW speed wiper mode. By moving the control again to the right (right most detent) will activate the HIGH speed wiper mode.

Depressing the control knob, in any mode, will result in washer fluid being squirted on the windshield.

Depressing the control knob on light duty trucks for one or two seconds will send a measured amount of fluid onto the windshield and then the washer will shut off. If the wiper control knob is any position other than HIGH, the wipers will continue to operate at low speed until they are manually turned OFF.

In the HIGH mode, depressing the knob results in washer fluid being dispensed with the wipers operating at the high speed mode.

### Selector Switch Checking Procedure

If the wiper washer selector switch is suspected of being faulty, it can be checked with an ohmmeter as indicated in Chart 8-16. Before performing any continuity check disconnect both harness connectors from switch to controller.

Next, place selector switch in mode desired and perform a continuity check between the individual leads as indicated in the chart. If there is a meter reading at each check but no indication of shorts, the switch can be assumed to be good.

## ON-VEHICLE SERVICE

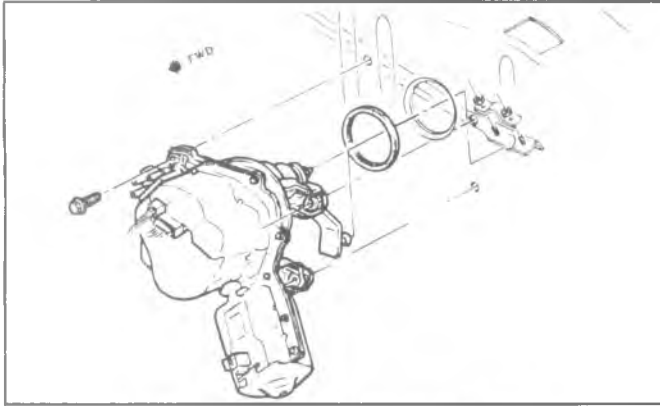

Fig. 8C-24--Wiper Motor (C-K Series)

### WIPER MOTOR

#### C-K Models

##### Replacement (Fig. 8C-24)

1. Make sure wiper motor is in Park position.
2. Open hood and disconnect ground cable from battery.
3. Disconnect electrical harness at wiper motor and hoses at washer pump.
4. Reach down through access hole in plenum and loosen wiper drive rod attaching screws. Remove drive rod from wiper motor crank arm.
5. Remove wiper motor to dash panel attaching screws and remove the motor assembly.
6. To install, reverse Steps 1-5 above.  
Lubricate wiper motor crank arm pivot prior to reinstallation.

#### G Series

##### Replacement (Fig. 8C-25)

1. Make sure wiper motor is in Park position.
2. Open hood and disconnect battery ground cable.
3. Remove wiper arms from wiper transmission linkage.
4. Remove remaining screws securing cowl panel cover and lift off.
5. Loosen nuts holding transmission linkage to wiper motor crank arm and lift linkage off arm.
6. Disconnect power feed to wiper motor at multiple connector.
7. Remove left dash defroster outlet from flex hose and push hose aside for access to wiper motor screws.
8. Remove one screw securing left hand heater duct to engine cover shroud and slip heater duct down and out.
9. Protect carpet, then remove windshield washer hoses from washer pump.
10. Remove three screws securing wiper motor to cowl and lift wiper motor out from under dash for further disassembly on bench.
11. To install, reverse Steps 1-10 above.

**NOTICE:** Install wiper in the PARK position. Lube wiper motor crank arm pivot prior to installation.

## UNIT REPAIR

### WIPER MOTOR

Repairs to the motor/gear box section of the wiper are limited to the switch, armature, and cap and brush holder assy., plus the external parts such as the crank arm, spacer/seal (plastic) and output shaft seal.

### PARK SWITCH

This is part of the washer pump relay coil assembly. Refer to figure 8C-26.

#### Removal

1. Disconnect wiring from wiper assembly and remove washer pump cover.
2. Remove pawl spring.
3. Push in retainer tab to release relay coil-park switch assembly from washer frame.
4. To re-assemble, reverse steps 1 thru 3 and check wiper operation, figure 8C-19.

### ARMATURE ASSEMBLY END CAP-BRUSH HOLDER ASSEMBLY

#### Replacement

1. Bend retainer tabs as required to provide clearance for removing end cap assembly. Figure 8C-27.
2. To assist in pushing the end of the motor housing, rotate crank arm clock-wise (looking at crankarm).
3. Pull end cap assembly off the armature shaft and pull armature out of wiper housing.

#### Replace

1. Release brush spring tension figure 8C-28 and slide brushes back in their respective brush holders.
2. Assemble armature in end cap assembly and reposition brush spring legs behind their respective tabs, figure 8C-29.
3. To maintain the end cap in its assembled position on armature shaft during re-assembly of armature in the wiper housing proceed as follows: Using small wire such as tag wire, tie armature to end cap assembly as shown in figure 8C-30.

4. Guide armature worm shaft through the housing bearing.

The strong magnetic field will pull armature toward one of the magnets. It will be necessary to overcome the magnetic force to start shaft into the bearing.

5. Guide terminal housing of end cap into the slot area of the wiper housing.
6. Remove wire used to attach armature to end cap. This should be done before end cap enters the housing.
7. After wire is removed, rotate crank arm slightly to permit armature worm shaft to engage gear teeth. The end cap assembly can then be pushed into the housing until it bottoms against the end of the housing.
8. Bend the 4 tabs as required to secure the end cap in position figure 8C-30.

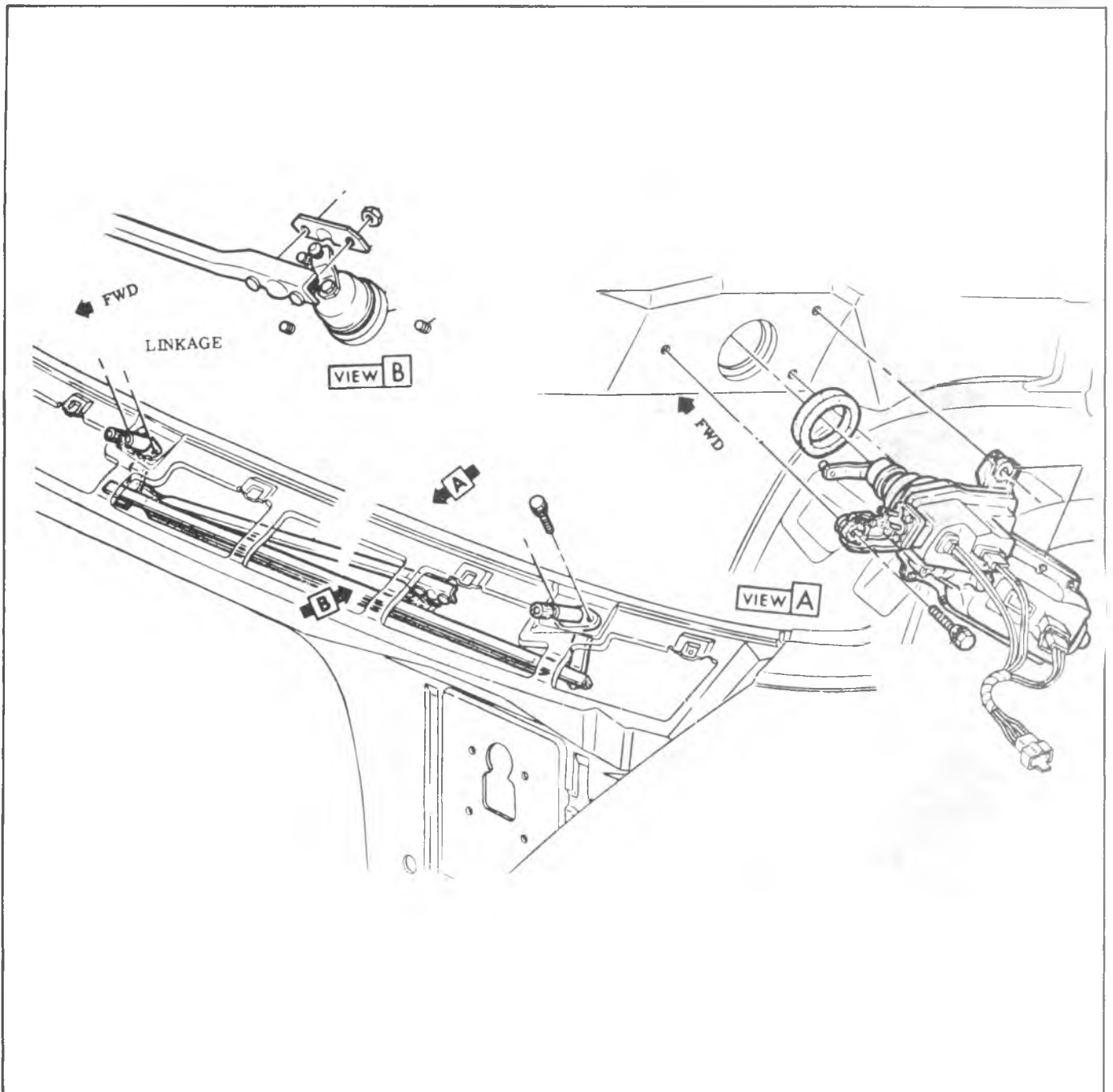

Fig. 8C-25--Wiper Motor (G Series)

9. Check wiper operation.

### CRANK ARM, SPACER, SEAL Refer to Figure 8C-31

#### Replacement

1. Remove crank arm retaining nut, crank arm, shaft seal and spacer in the order indicated.  
When re-assembling the shaft seal, be sure flat side is toward crank arm.
2. When re-assembling the crank arm, be sure wiper motor is in park (refer to figure 8C-32), and assemble crank arm on shaft in position shown in Figure 8C-32.

### WASHER PUMP

#### Relay Coil

This is part of park switch assembly. Refer to "Park switch" for disassembly-assembly procedure.

#### Ratchet Pawl

Refer to Figure 8C-33.

1. Disconnect pawl spring.
2. Remove "e" type retainer ring and slip pawl off of shaft.

#### Dog Spring: Refer to Figure 8C-33

1. Remove screw that attaches dog spring to washer frame.

CONNECTIONS TO OPERATE WIPERS INDEPENDENTLY OF VEHICLE WIRING AND DASH SWITCH.

NO LOAD CURRENT DRAW @ 12V  
 Lo Speed — 2.5 Amps Max  
 Hi Speed — 5.0 Amps Max  
 Crank Arm Rotation — CCW  
 (Looking at Arm)

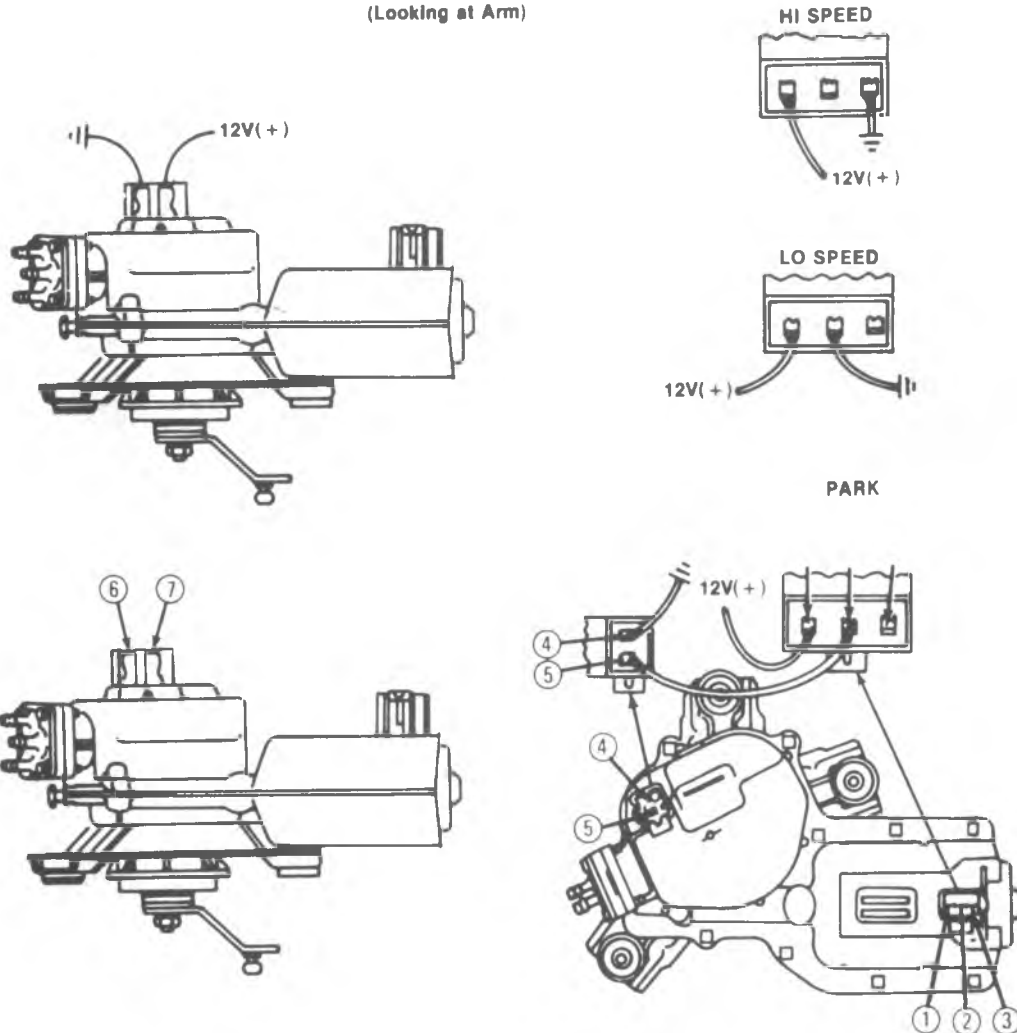

Fig. 8C-26--Checking Motor Operation

**Ratchet Gear: Refer to Figure 8C-33**

1. Remove dog spring and ratchet pawl.
2. Move leg of retainer spring out of shaft groove and slide ratchet gear off shaft. Be careful not to lose retainer spring.
3. To re-assemble gear, reverse steps 1 and 2 but read note.

In order to push gear on shaft until it bottoms, move ratchet pawl shaft in a direction away from the gear. This will allow gear collar to slide past the tab on the piston actuator plate. (Refer to Figure 8C-24).

**Piston and Housing Assy:**

Refer to Figure 8C-34.

1. Remove ratchet pawl, dog spring and ratchet gear.

2. Pull piston housing away from frame until the mounting grooves clear the frame. During this step the piston spring is being compressed.
3. Remove valve assembly as required.
4. To re-assemble, reverse steps 1 thru 3.

**Valve Assembly: Refer to Figure 8C-33.**

1. Remove the four (4) attaching screws and remove valve assembly and gasket ring.
2. During re-assembly, be sure seal is properly installed in piston housing and valve assembly grooves.

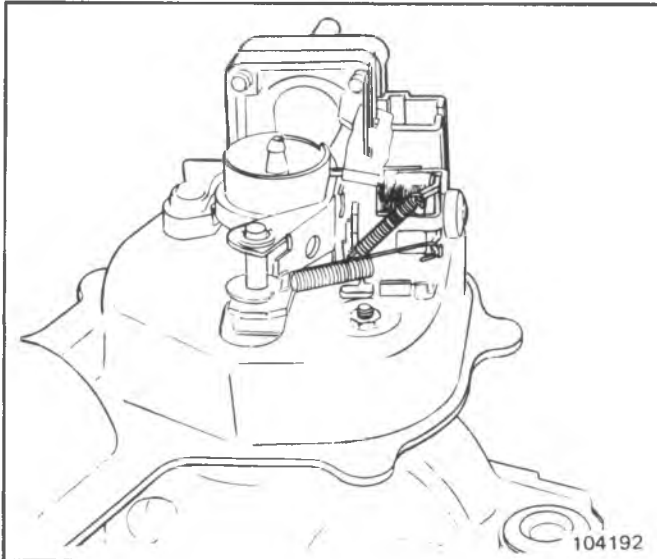

Fig. 8C-27--Relay Coil Assembly

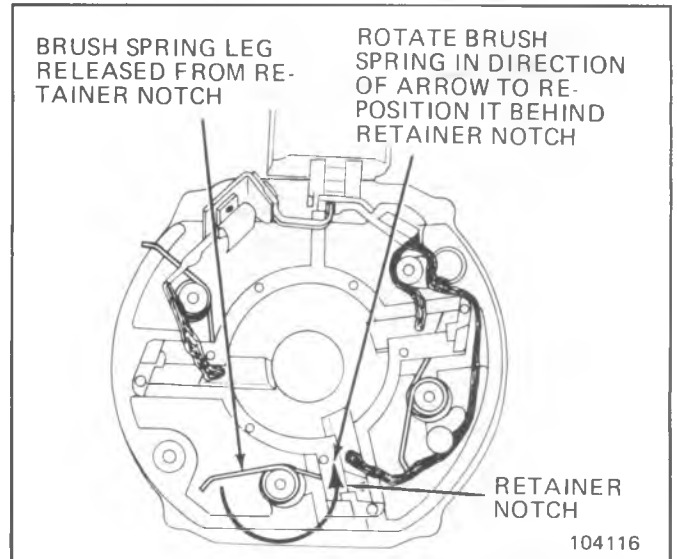

Fig. 8C-28--Releasing Brush Spring Tension

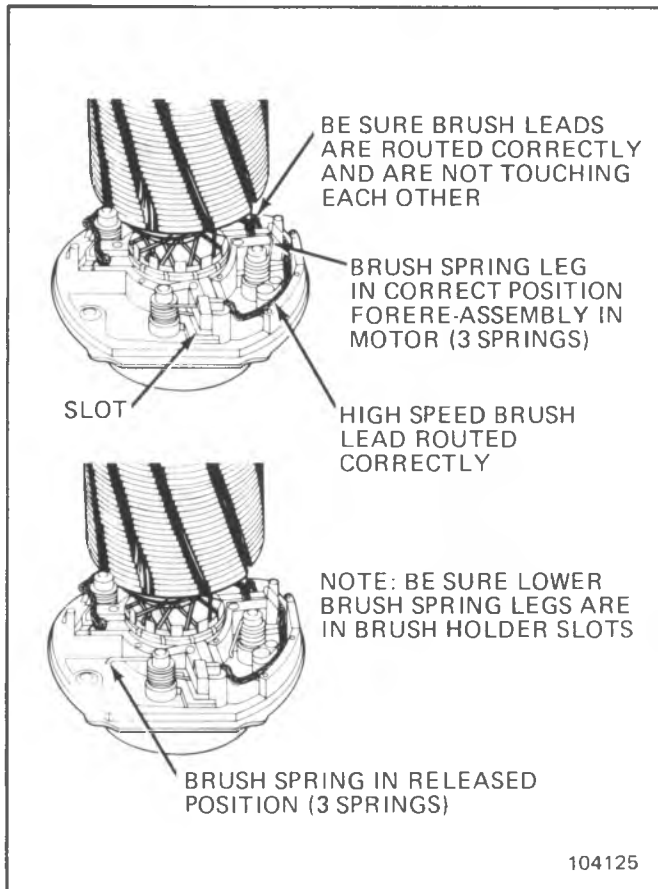

Fig. 8C-29--Brush Spring--Brush Spring-Released Position

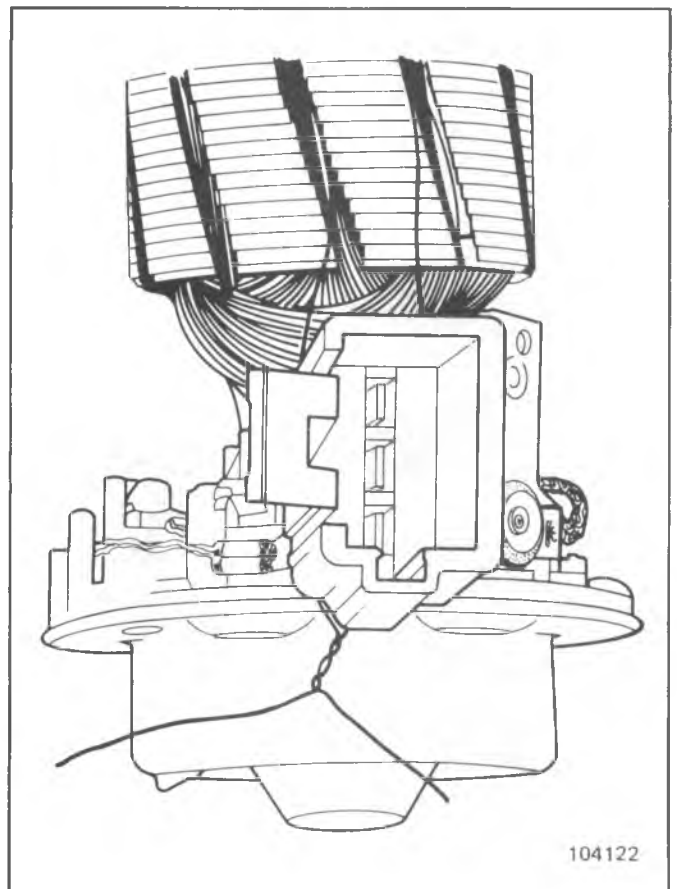

Fig. 8C-30--End Cap Assembly



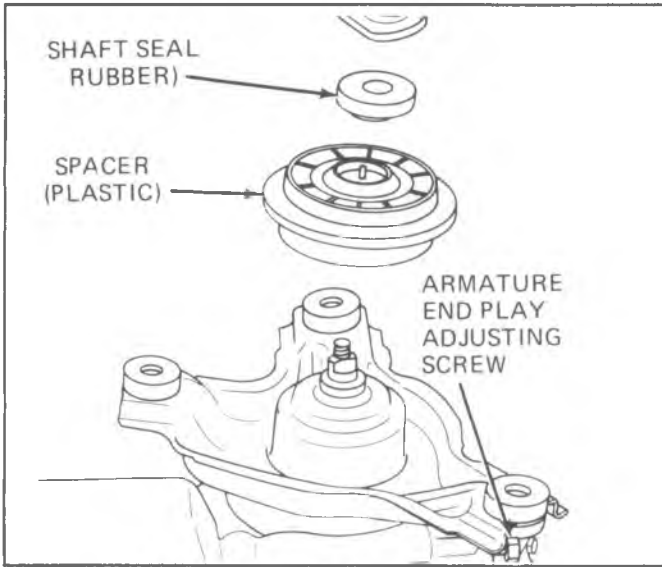

Fig. 8C-31--Crank Arm Spacer Seal

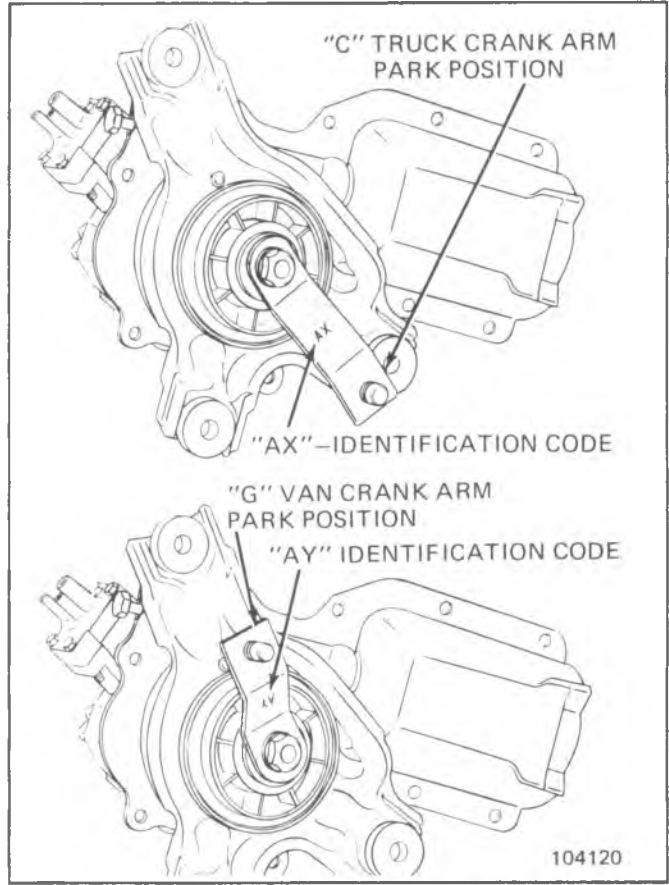

Fig. 8C-32--Crank Arm Park Position

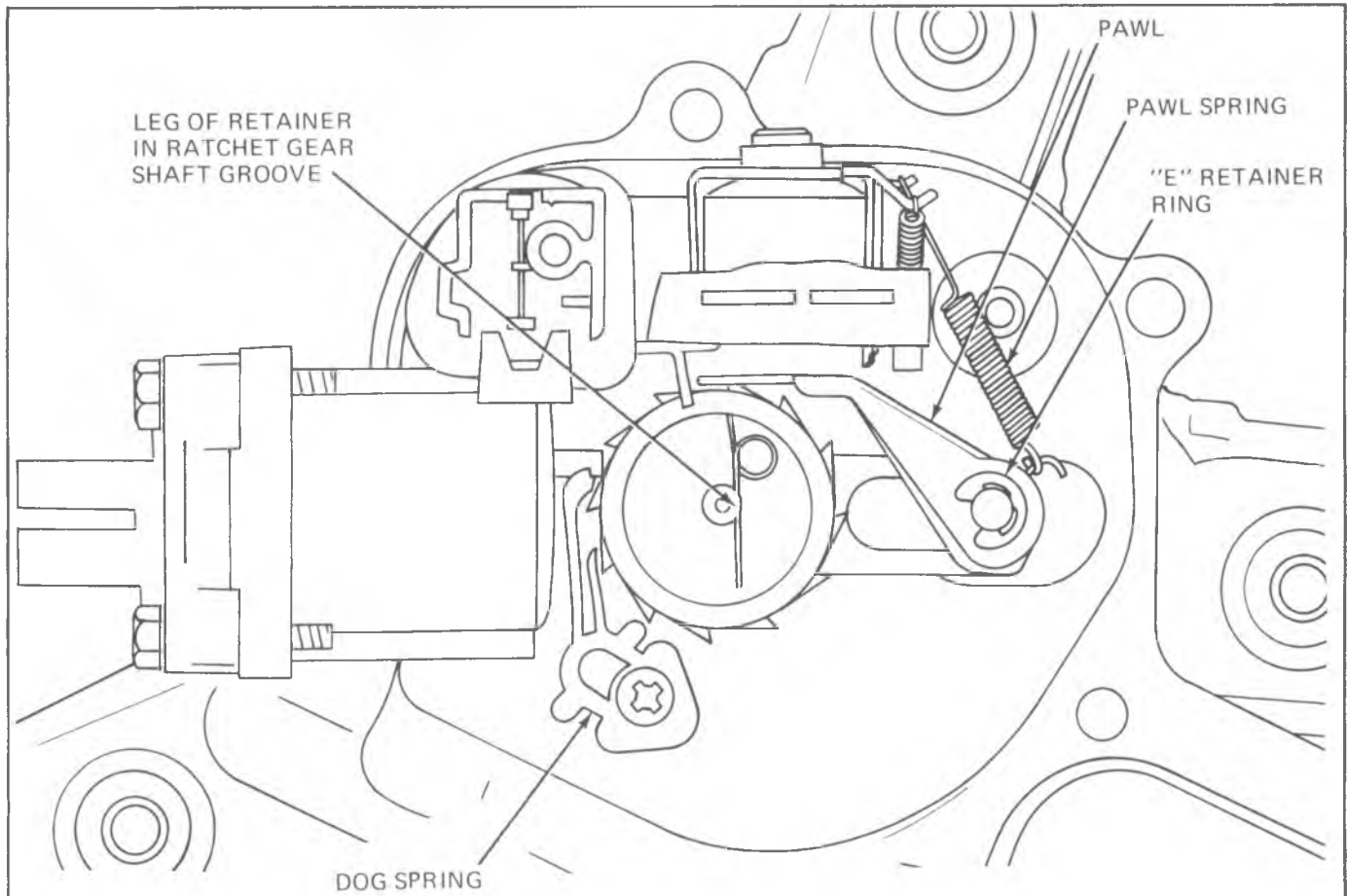

Fig. 8C-33--Washer Pump Assembly

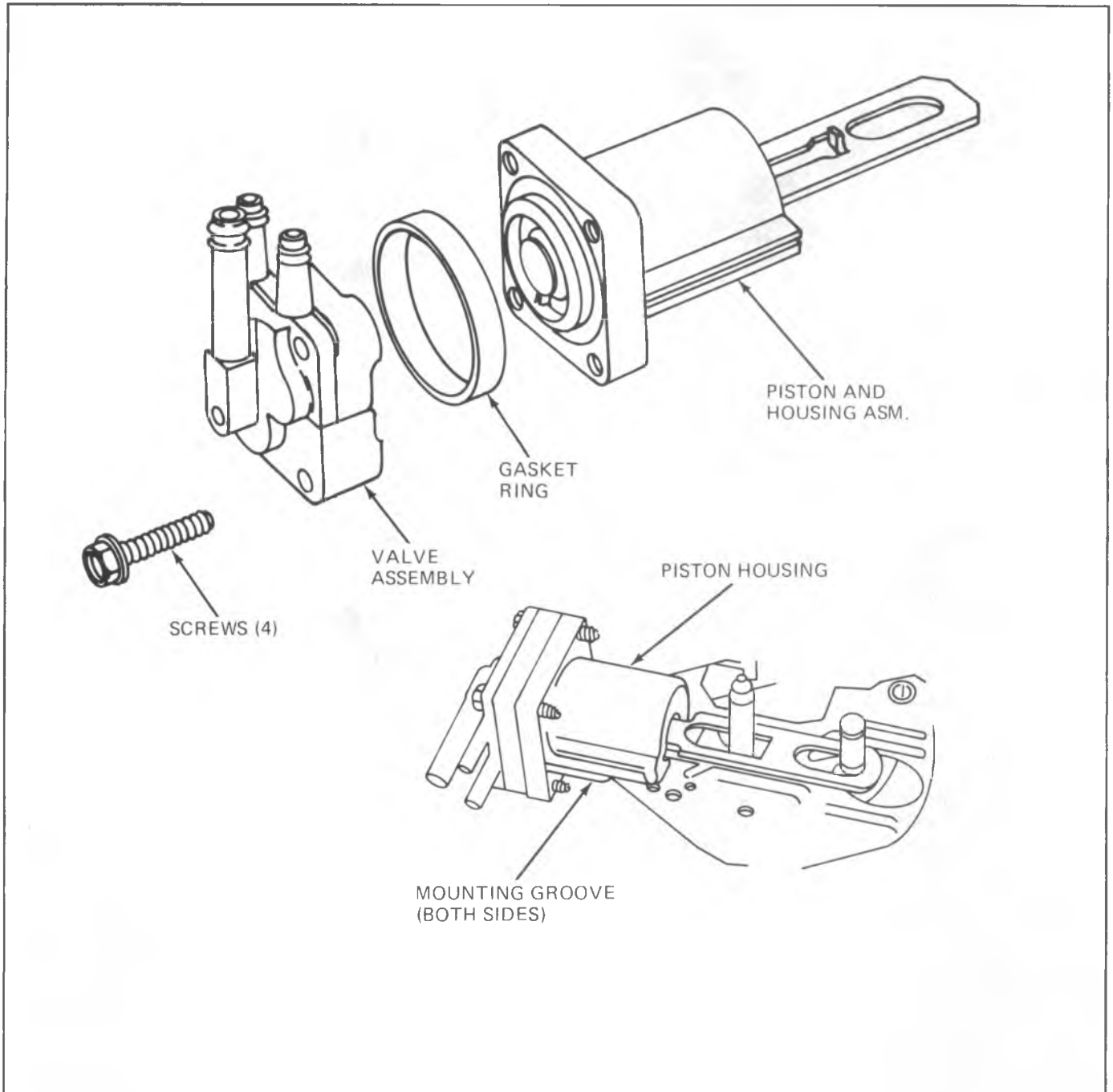

Fig. 8C-34--Washer Pump Exploded View

## WINDSHIELD WIPER AND WASHER

### P MODELS

#### GENERAL DESCRIPTION

The system consists of a compound wound rectangular-shaped motor attached to a gear box containing a parking switch in addition to the gear train. The gear train consists of a motor armature helical gearshaft which drives an intermediate gear and pinion assembly. The pinion gear of the intermediate gear and pinion drives an output gear and shaft assembly.

Turning the wiper switch to the LO speed position completes the circuits from the wiper terminals 1 and 3 to ground. Current then flows from the battery via wiper terminal No. 2 through the series field and divides; (1) part passes through the armature to ground via wiper terminal No. 1 to the wiper switch and (2) the second part passes through the shunt field to ground through wiper terminal No. 3 to the wiper switch (fig. 8C-35).

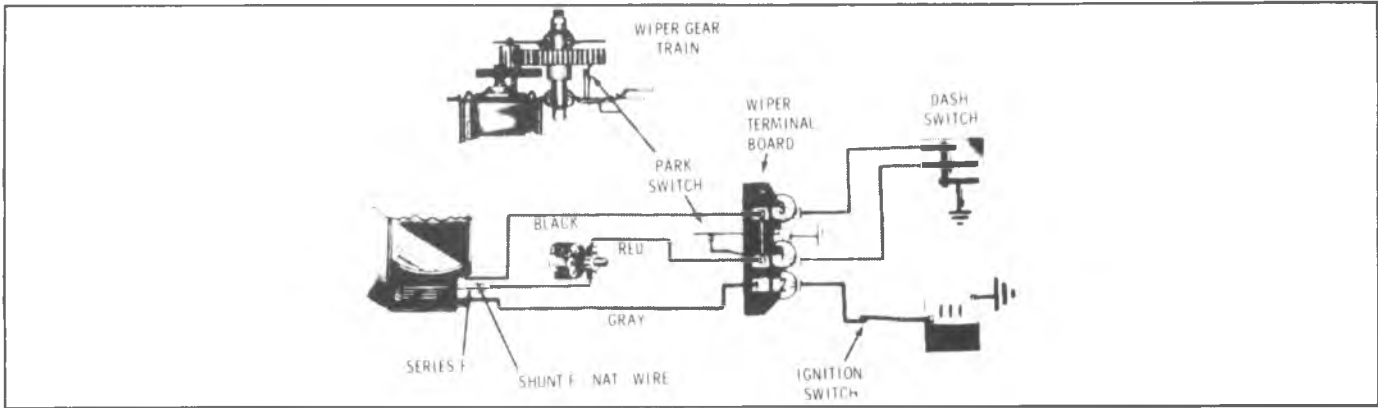

Fig. 8C-35--LO Speed Circuit

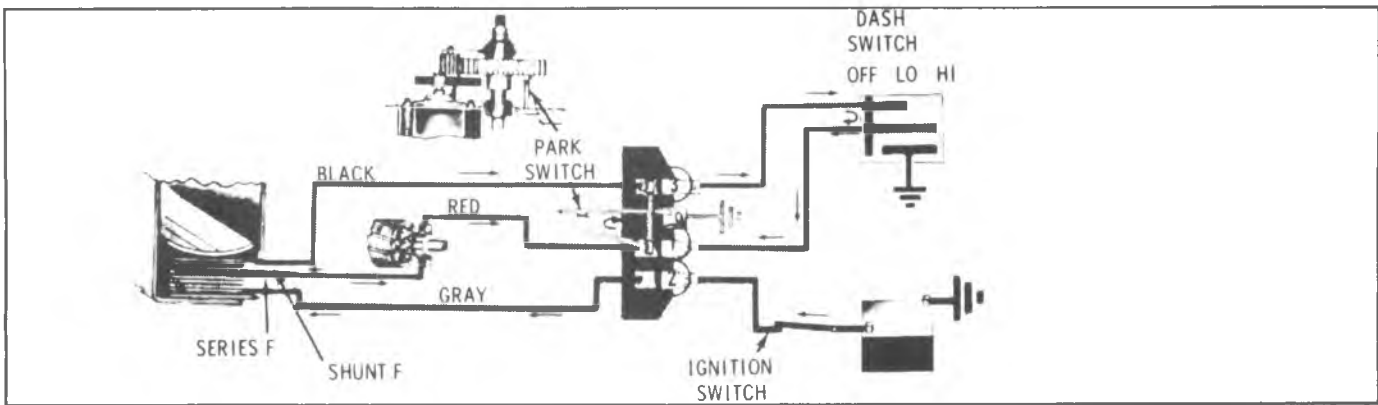

Fig. 8C-37--PARKING Circuit

The wiper switch must be securely grounded to body metal.

Moving the wiper switch to the HI speed position opens the shunt field circuit to ground at the switch. However, the shunt field is connected to a 20 ohm resistor which is connected across wiper terminals 1 and 3. The shunt field current then flows via terminal No. 1 through the resistor to terminal No. 3 through the switch, to ground (fig. 8C-36).

The parking circuit covers that portion of wiper operation when the wiper switch is turned "off" and the wiper blades have not reached the park position.

When the wiper blades are not in the normal park position, the parking switch contacts are still closed. The wiper will continue to operate until the wiper output gear is turned to a position where its cam opens the park switch.

Referring to Figure 8C-37, it can be seen that the wiper motor circuits are completed to ground through the parking switch.

The wiper motor must be securely grounded to body metal.

The shunt field circuit is completed from terminal No. 3 via the switch to terminal No. 1 through the parking switch to ground. The series field and armature circuit is also completed from terminal No. 1 through the parking switch to ground.

The shunt field is connected direct to ground, bypassing the resistor. This results in LO speed operation during the parking operation.

When the output gear cam opens the park switch contacts, the wiper is OFF.

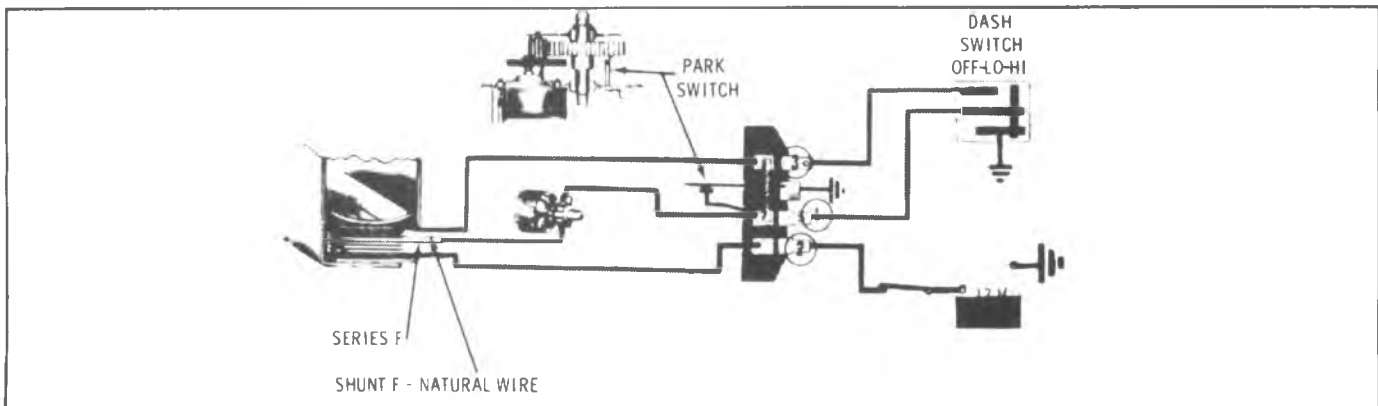

Fig. 8C-36--HI Speed Circuit

## DIAGNOSIS

### WIPER - ON VEHICLE

1. Inspect for the following items:
  - a. Wiring harness is securely connected to wiper and switch.
  - b. Wiper motor is securely grounded to body.
  - c. Wiper switch is securely mounted and grounded.
  - d. Check fuse.
2. If items in Step 1 check out, try operating wiper in both "LO" and "HI" speeds, then turn wiper off (blades should return to park position). If wiper fails to operate correctly, proceed to Step 3.
3. Disconnect wiring harness from wiper and try operating wiper as shown in Figure 8C-31
  - a. If wiper operates correctly independently of switch and vehicle wiring, refer to the DIAGNOSIS CHART - WIPER ON VEHICLE.
  - b. If wiper still fails to operate correctly in Step 3, disconnect wiper linkage from motor crankarm and try operating wiper again. If wiper operates correctly independently of linkage, check linkage for cause of wiper malfunction.
  - c. If wiper fails to operate correctly independently of linkage, remove wiper motor from vehicle and refer to DIAGNOSIS CHART-WIPER OFF VEHICLE.

| CONDITION  | APPARENT CAUSE   | CORRECTION  |
|--|--|---|
| 1. Wiper Inoperative or intermittent   | <p>A. Blown fuse</p> <p>B. Open circuit in feed wire (No. 2 terminal on wiper motor)</p> <p>C. Loose mounting of wiper switch</p> <p>D. Defective wiper switch</p> <p>E. Open circuit in wire to wiper switch (No. 1 terminal on wiper motor)</p>  | <p>A. Locate short circuit and repair. Replace fuse.</p> <p>B. Locate broken wire and repair</p> <p>C. Tighten switch mounting</p> <p>D. Replace switch</p> <p>E. Locate broken wire and repair</p> |
| <p>2. Wiper will not shut off:</p> <p>A. Wiper has both "Lo" and "Hi" speeds</p> <p>B. Wiper has "Lo" speed only</p> <p>C. Wiper has "Hi" speed only</p> | <p>A. Grounded Wire (No. 1 terminal on wiper motor) to wiper switch</p> <p>A. Defective wiper switch</p> <p>B. Grounded wire (No. 3 terminal on wiper motor) to wiper switch</p> <p>A. Defective wiper switch</p> <p>B. Open circuit in wire (No. 3 terminal on wiper motor) to wiper switch</p> | <p>A. Locate short circuit and repair</p> <p>A. Replace wiper switch</p> <p>B. Locate and repair short circuit</p> <p>A. Replace wiper switch</p> <p>B. Locate and repair broken wire</p>           |
| 3. Wiper has "Hi" speed only   | A. Open circuit in wire (No. 3 terminal on wiper motor) to wiper switch  | A. Locate broken wire and repair  |
| 4. Wiper has "Lo" speed only   | <p>A. Grounded wire (No. 3 terminal on wiper motor) to wiper switch</p> <p>B. Defective wiper switch</p>   | <p>A. Locate short circuit and repair</p> <p>B. Replace wiper switch</p>  |
| 5. Blades do not return to full park position  | A. Loose wiper ground strap connection   | A. Tighten strap connection   |

| CONDITION  | APPARENT CAUSE  | CORRECTION  |
|--|---|---|
| 1. Wiper Inoperative or Intermittent   | A. Broken or damaged gear train (only if inoperative)<br>B. Poor solder connections at terminal board<br>C. Loose splice joints at brush plate<br>D. Brushes binding in brush holder<br>E. Open circuit in armature | A. Replace gears as required<br>B. Resolder wires at terminals<br>C. Recrimp or solder splice joints<br>D. Clean holder or replace brush, spring or brush plate assembly.<br>E. Replace armature  |
| 2. Wiper will not shut-off:<br>A. Wiper has normal "Hi" and "Lo" speed<br><br>B. Wiper has "Lo" speed only<br><br>C. Wiper has "Hi" speed only | A. Defective park switch<br>B. Grounded red lead wire<br><br>A. Grounded shunt field coil<br>B. Grounded black wire<br><br>A. Open circuit in shunt field coil<br>B. Open circuit in black wire                     | A. Replace terminal board assembly<br>B. Repair short circuit in red wire<br><br>A. Replace frame and field assembly<br>B. Repair short circuit in black wire<br><br>A. Replace frame and field assembly<br>B. Repair broken wire or poor solder connection |
| 3. Wiper shuts off - but not in park position  | A. Park switch defective or contacts dirty  | A. Replace terminal board assembly or clean contacts  |
| 4. "Hi" speed too fast   | A. Resistor defective   | A. Replace terminal board assembly  |

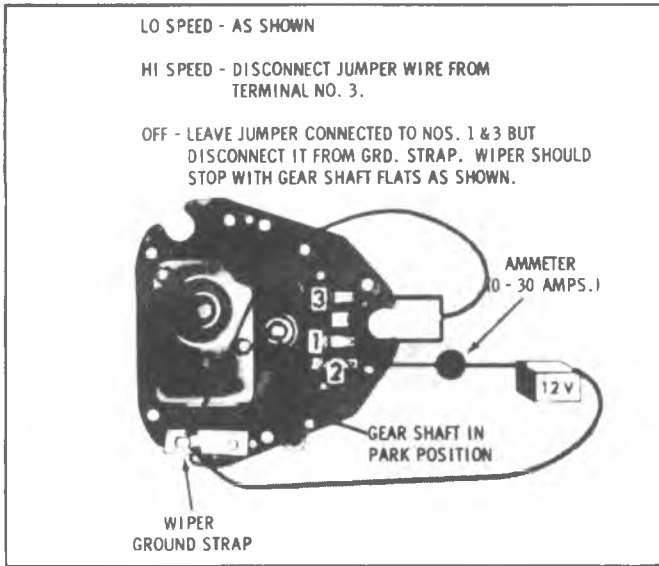

Fig. 8C-38--Jumper Wire Connections

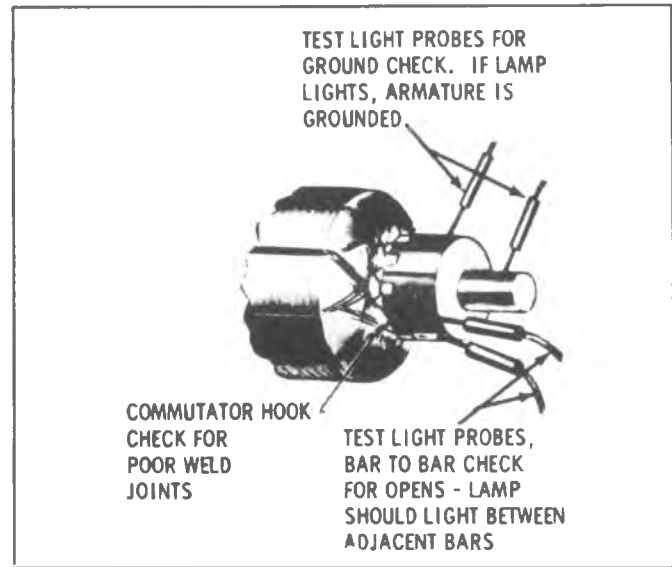

Fig. 8C-39--Checking Armature

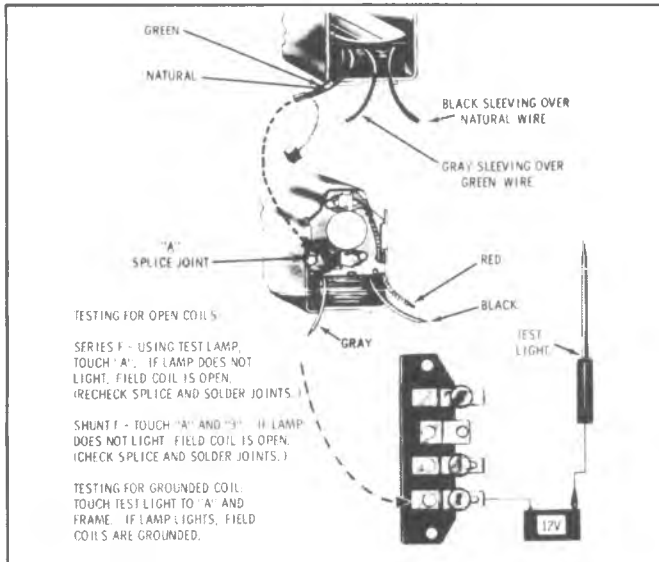

Fig. 8C-40--Testing Field Coils

| CONDITION  | APPARENT CAUSE  | CORRECTION   |
|--|---|--|
| 1. Washers inoperative                                 | <p>A. Inadequate quantity of washer solution</p> <p>B. Hoses damaged or loose</p> <p>C. Plugged screen at end of jar cover hose</p> <p>D. Loose electrical connection to washer pump or wiper switch</p> <p>E. Open circuit in feed wire to ratchet relay coil</p> <p>F. Wiper switch defective</p> <p>G. Ratchet relay coil defective</p> <p>H. Washer nozzles plugged</p> <p>I. Ratchet wheel tooth missing</p> <p>J. Ratchet pawl spring missing</p> <p>K. Defective pump valve assembly</p> | <p>A. Add washer solution</p> <p>B. Cut short length off end of hose to insure air tight connection or replace hose</p> <p>C. Clean screen</p> <p>D. Check electrical connections and repair if necessary</p> <p>E. Locate open circuit and repair</p> <p>F. Replace wiper switch</p> <p>G. Replace ratchet relay</p> <p>H. Clean washer nozzles</p> <p>I. Replace ratchet wheel</p> <p>J. Replace ratchet pawl spring</p> <p>K. Replace pump valve assembly</p> |
| 2. Washer pumps continuously when wipers are operating | <p>A. Grounded wire from ratchet relay to switch</p> <p>B. Wiper switch defective</p> <p>C. Ratchet wheel tooth missing</p> <p>D. Ratchet wheel dog broken or not contacting ratchet wheel teeth</p> <p>E. Lock-out tang broken or bent on piston actuating plate</p>   | <p>A. Locate grounded wire and repair</p> <p>B. Replace wiper switch</p> <p>C. Replace ratchet wheel</p> <p>D. Replace or repair ratchet wheel dog</p> <p>E. Replace piston actuating plate</p>  |



## ON-VEHICLE SERVICE

### WIPER MOTOR

Wiper motor replacement procedures are not included here since installation is performed by the individual body

manufacturers; however, disassembly of the unit will be covered.

## UNIT REPAIR

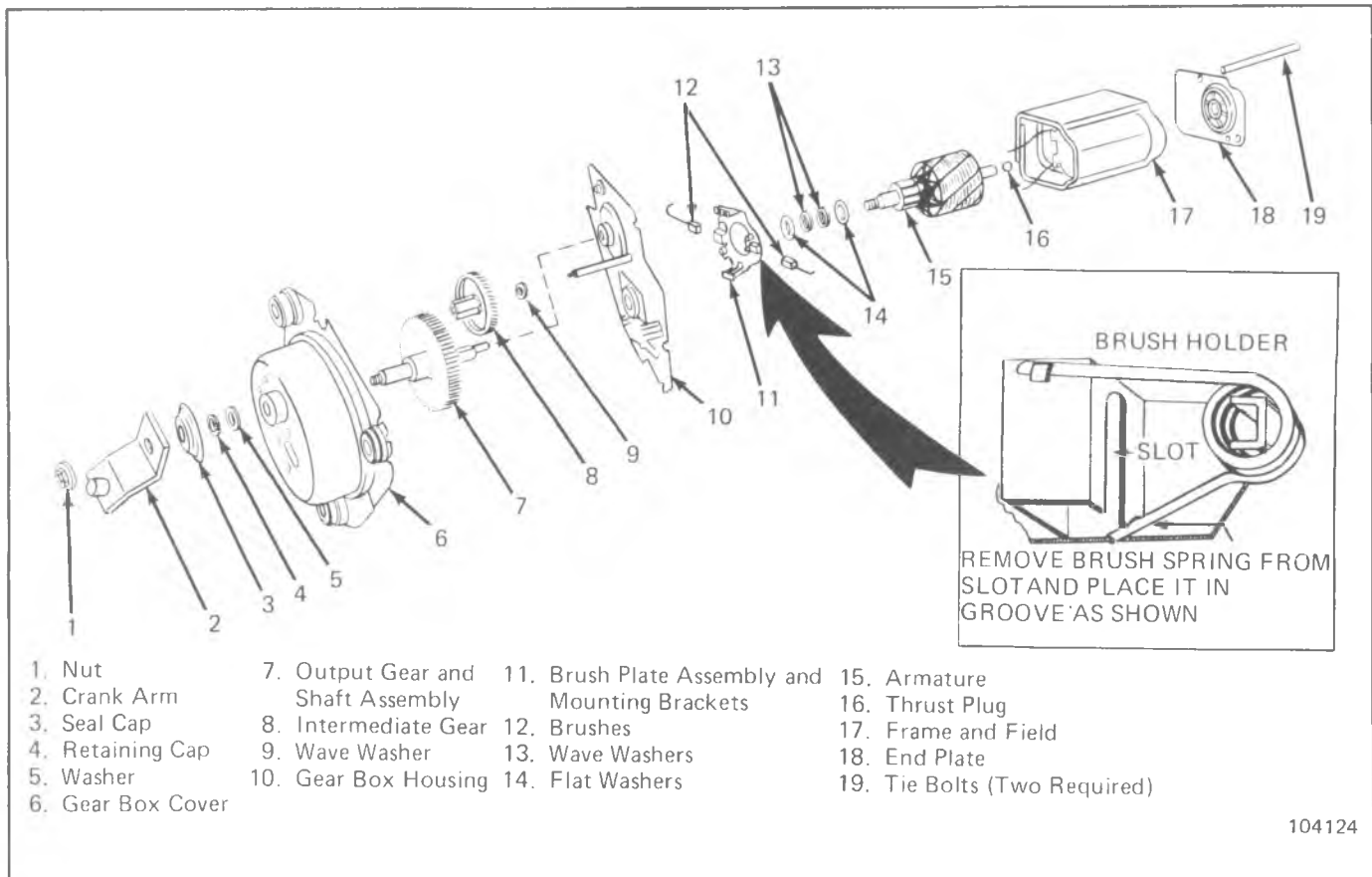

Fig. 8C-41--Wiper Motor and Gear Box Assembly

### WIPER MOTOR

#### Disassembly (Fig. 8C-41)

##### Gear Box

1. Remove the two washer pump mounting screws and lift pump off washer.
2. Remove washer pump drive cam as required (figs. 8C-40 and 8C-41). The cam is pressed on the shaft but can be wedged off by using two screwdrivers between cam and plate.
3. Clamp crank arm in a vise and remove crank arm retaining nut.

**NOTICE:** Failure to clamp crank arm may result in stripping of wiper gears.

4. Remove crank arm, seal cap, retaining ring, and end-play washers.

Seal cap should be cleaned and repacked with a waterproof grease before reassembly.

5. Drill out gear box cover retaining rivets, remove cover from gear train.

Screws, nuts and lockwashers for reassembling cover to wiper are contained in the service repair package.

6. Remove output gear and shaft assembly, then slide intermediate gear and pinion assembly off shaft.
7. If necessary, remove terminal board and park switch assembly as follows:
  - a. Unsolder motor leads from terminals. Code motor leads.
  - b. Drill out rivets securing terminal board and park switch ground strap to mounting plate. Screws, nuts and washers for attaching a replacement terminal board park switch assembly are included with the replacement assembly.

##### Motor

1. Follow Steps 1 through 7b under gear box disassembly.
2. Remove motor through bolts, tap motor frame lightly, and remove motor from mounting plate.
3. Remove brush spring tension (fig. 8C-41), slide armature and end plate from motor frame. Pull end plate from armature.

Thrust plug located between armature shaft and end

104124

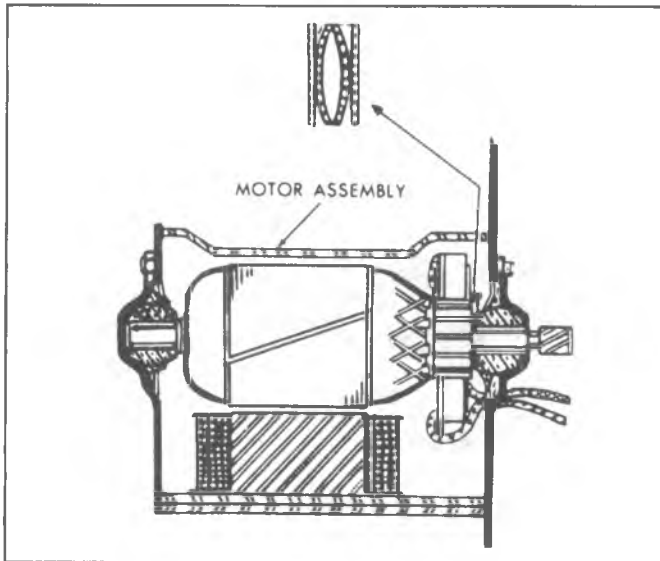

Fig. 8C-42--End Play Wave Washer Installation

plate.

4. Remove end play adjusting washers from armature, noting arrangement for proper reinstallation.

**Inspection**

Check and inspect all parts for wear; replace as necessary. All parts can be replaced individually except motor frame and field, which is serviced as an assembly. Service kits also provide screws, nuts and washers to replace gear cover and terminal board rivets.

**Assembly**

Refer to Figure 8C-41 for exploded view of motor and gear train.

**Motor**

Reassemble motor using reverse of disassembly procedure.

Armature end play is controlled by end play washers. See Figure 8C-42 for proper assembly of end play washers. Lubricate armature shaft bushings with light machine oil.

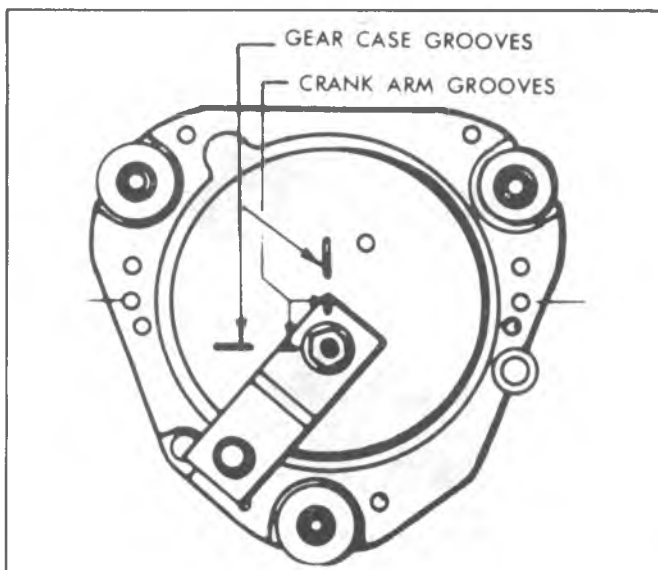

Fig. 8C-43--Wiper Motor Crank Arm in Park Position

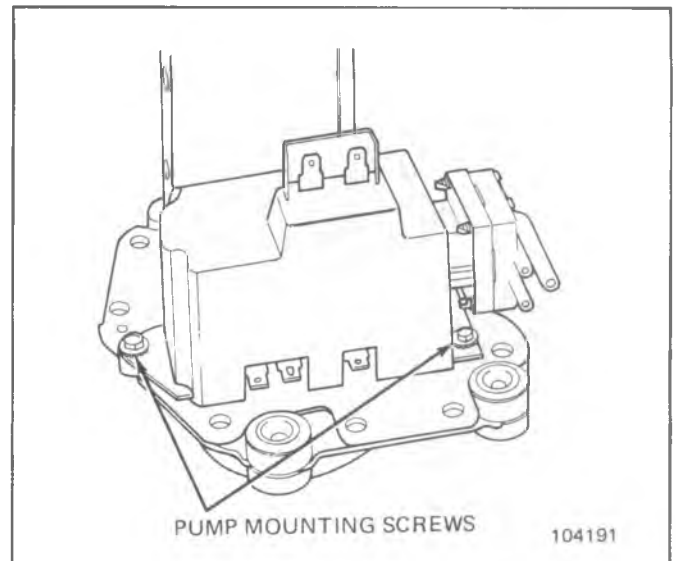

Fig. 8C-44--Washer Pump Attaching Screws

**Gear Box**

1. Assemble gear box using reverse of disassembly procedure.

Lubricate gear teeth with Delco Cam and Ball Bearing lubricant (or equivalent). Be sure cover is properly located over dowel pins and be sure to reinstall ground strap.

2. Place wiper in park position and install crank arm on output shaft, rotate crank so alignment marks line up with those on cover (fig. 8C-43).
3. Replace retaining nut, place crank arm in vise, tighten retaining nut.

**WINDSHIELD WASHER**

The positive displacement washer pump used on the two-speed non-depressed park wipers (fig. 8C-44) use a pump mechanism consisting of a piston, piston spring and valve arrangement driven by a (4) lobe cam, and follower assembly (fig. 46). The cam is attached to one shaft of the wiper motor output gear (fig. 8C-45). Programming is accomplished

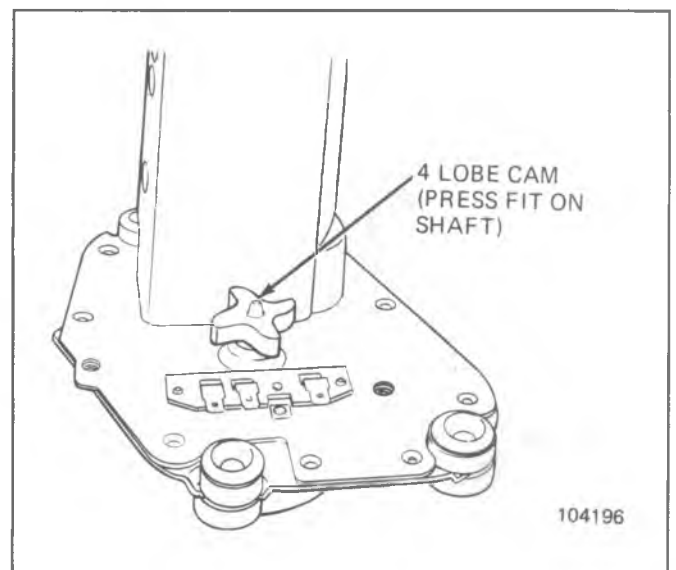

Fig. 8C-45--Washer Pump Drive Cam

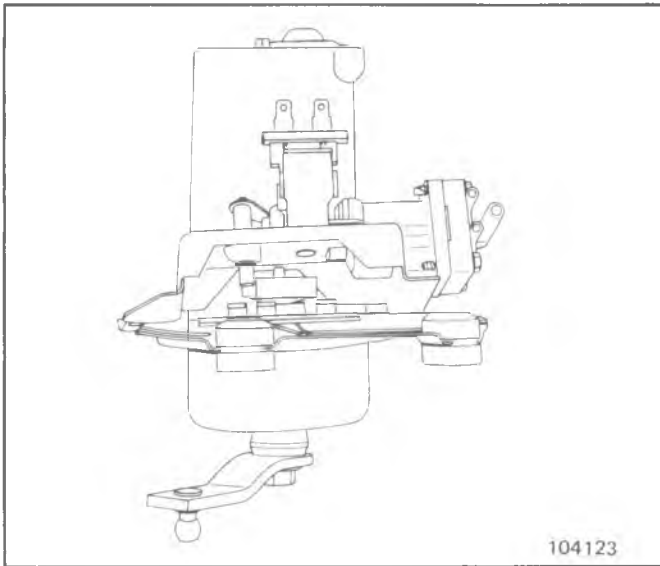

Fig. 8C-46--Washer Pump Drive Cam and Actuator

electrically and mechanically by a relay assembly and ratchet wheel arrangement.

**Replacement**

1. Disconnect battery ground cable.
2. Remove two pump mounting bolts.
3. Remove washer pump assembly.
4. To install reverse Steps 1-3 above. Install washer multiplug harness connector with battery lead on terminal with no tang (fig. 8C-44). Incorrect installation of connector will result in direct ground and destroy wiper motor fuse.

**Disassembly-Assembly (Figures 8C-47 thru 8C-50)**

1. Remove washer pump cover by squeezing.
2. Solenoid assembly - ratchet dog.
  - a. Remove ratchet dog retaining screw. Hold spring loaded solenoid plunger in position and carefully lift solenoid assembly and ratchet dog off frame of pump.
  - b. Separate ratchet dog from solenoid mounting plate as required.
3. Ratchet pawl.

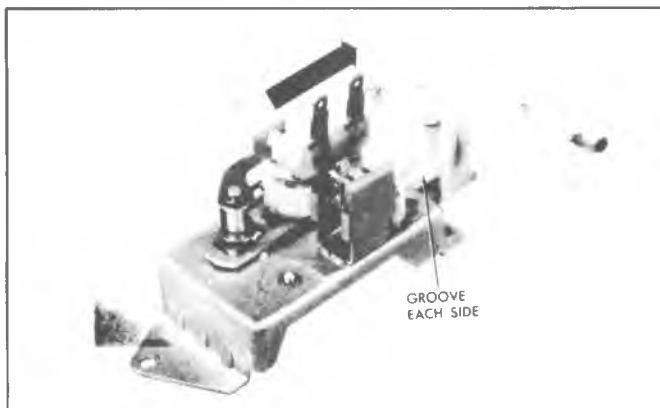

Fig. 8C-49--Releasing Pump From Lockout Position

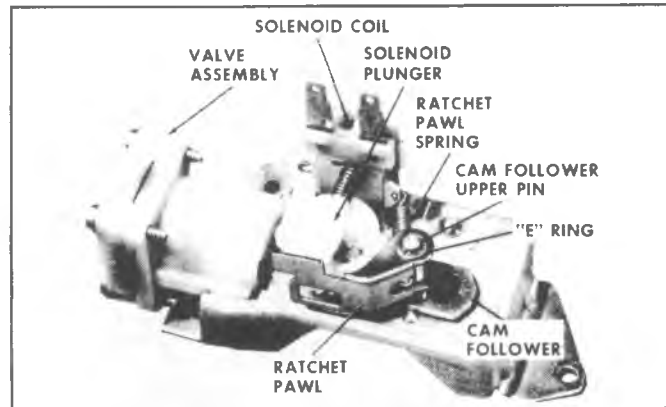

Fig. 8C-47--Washer Pump Mechanism

- a. Disconnect ratchet pawl spring.
- b. Remove ratchet pawl retaining ring and slide ratchet pawl off cam follower shaft.
4. Ratchet wheel.
  - a. Follow Step 1 under solenoid - ratchet dog disassembly.
  - b. Move ratchet wheel spring out of shaft groove and slide ratchet wheel off its shaft.
5. Pump and actuator plate assembly.
  - a. Remove solenoid assembly - ratchet pawl and ratchet wheel as outlined in their respective procedures.
  - b. To separate pump and pump actuator plate from frame, pull pump housing in direction of the arrow until grooves in housing clear the frame. Then remove actuator plate from ratchet wheel and cam follower shafts.
6. Valve assembly.
  - a. Remove four screws that attach the valve assembly to pump housing.

During assembly, be sure gasket between housing and valve plate is properly positioned in housing and valve plate grooves. Also be sure triple "O" ring is properly installed between valve body and pipe assembly.

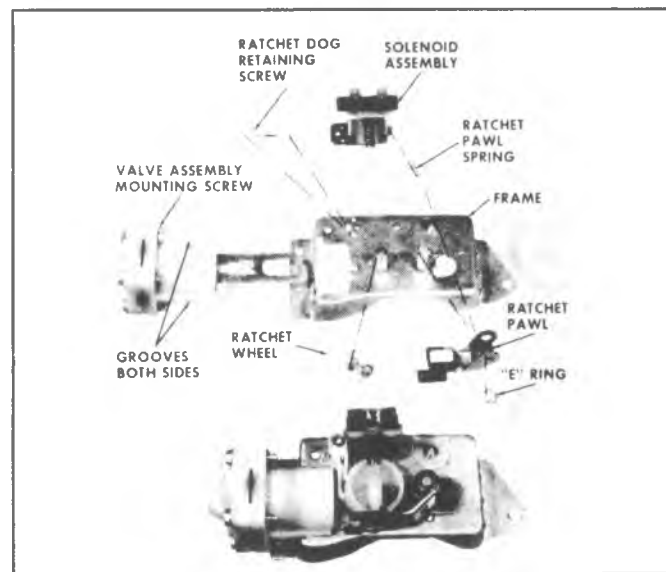

Fig. 8C-48--Washer Pump-Exploded View

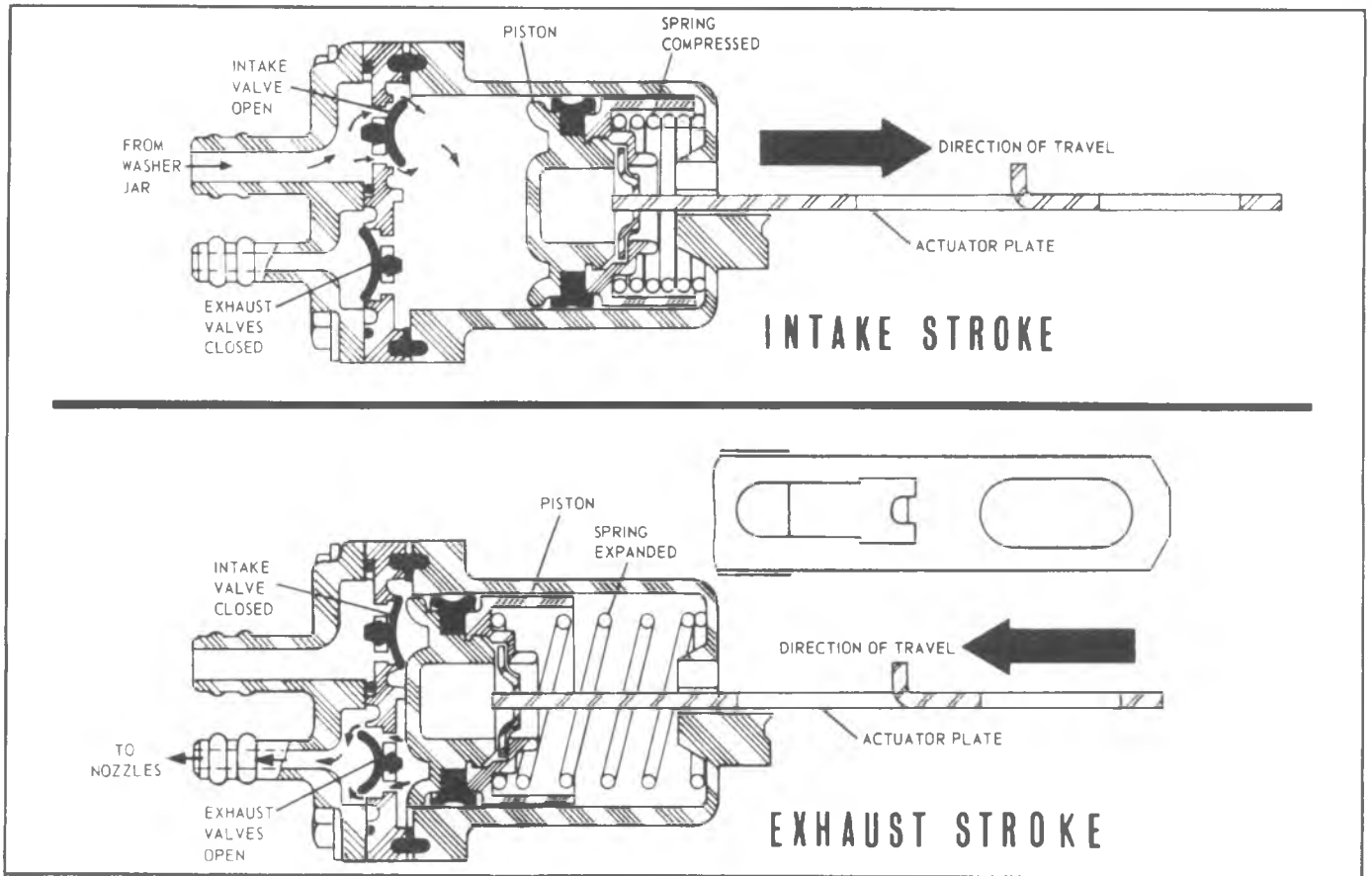

Fig. 8C-50--Cross Section of Windshield Washer Pump Valve



# SECTION 9

## ACCESSORIES

### TABLE OF CONTENTS

|  |     |                                 |      |
|--|-----|---------------------------------|------|
| Custom Cruise 111                        |     | Preliminary Inspection          | 9-6  |
| General Description                      | 9-1 | Test Procedures                 | 9-6  |
| System Components                        | 9-1 | Cruise System Inoperative       | 9-6  |
| General                                  | 9-2 | Cruise System Surges            | 9-10 |
| Component Functions                      | 9-2 | Cruise 'Set' Speed, High or Low | 9-10 |
| Electrical/Vacuum System Operation       | 9-2 | Servo Adjustments               | 9-13 |
| Custom Cruise 111 System                 | 9-4 | Radio                           | 9-14 |
| Custom Cruise 111 System                 |     | General Description             | 9-14 |
| Diagnosis                                | 9-4 | Diagnosis                       | 9-15 |
| Controller and Related Circuit Operation | 9-4 | On-Vehicle Service              | 9-27 |

## CUSTOM CRUISE 111

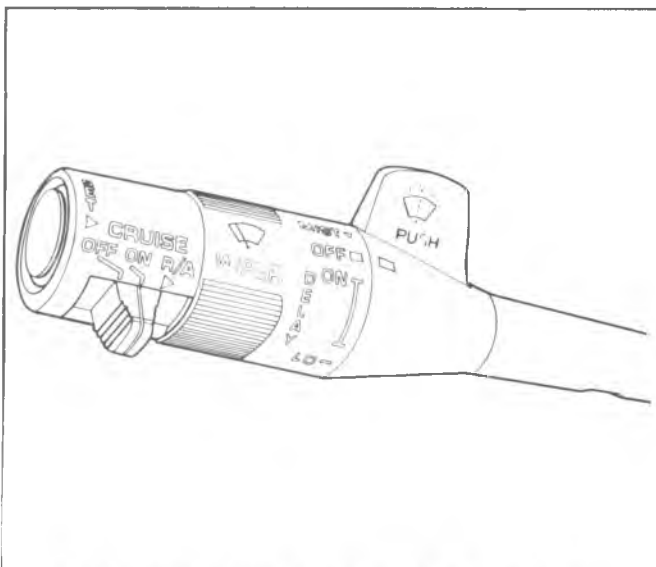

Fig. 9-1--Mode Control Switches on Turn Signal Lever—G Van Models

### GENERAL DESCRIPTION

The Custom Cruise 111 system has been adapted to accommodate the lower manifold vacuum levels of more fuel efficient vehicles.

The cruise control functions of cruise, coast, resume speed and accelerate are built in the turn-signal lever (Figures 9-1 and 9-2).

To engage the cruise mode, the slide lever must be moved from the "off" to the "on" position and the "set" push button (located in the end of the turn signal lever) must be depressed and released. The cruise set speed will be the vehicle speed at the particular time when the "set" push button is released. However, there is no cruise engagement below 25 mph. This is a low speed inhibit feature. The system may be disengaged by moving the mode control switch to the "off" position or by depressing the vehicle brake pedal or clutch pedal.

If the brake pedal is momentarily depressed to disengage cruise operation, the cruise set speed will be

retained in the system memory. To return the vehicle to the previously set cruise speed, *MOMENTARILY* move the slider to the R/A (Resume/Accel) position.

**Do not hold the slider in the R/A position, release it immediately.**

If the slider is held in the R/A position for more than one second, the system reverts to the **ACCEL** mode. When the slider is released, the speed the vehicle accelerated to becomes the new cruise speed. The vehicle operator may erroneously interpret this as an inoperative resume function.

The vehicle will automatically accelerate the previously set speed at a controlled rate. The controller "remembers" the last cruise speed unless "cleared" by an on-off of the ignition switch or the slider switch on the turn signal lever.

If the slider is moved to the "R/A" position while in cruise and held, the vehicle will accelerate at a controlled rate until the slider is released. When the slider is released, the vehicle will continue to cruise at that speed. Reducing "set" speed can be accomplished by

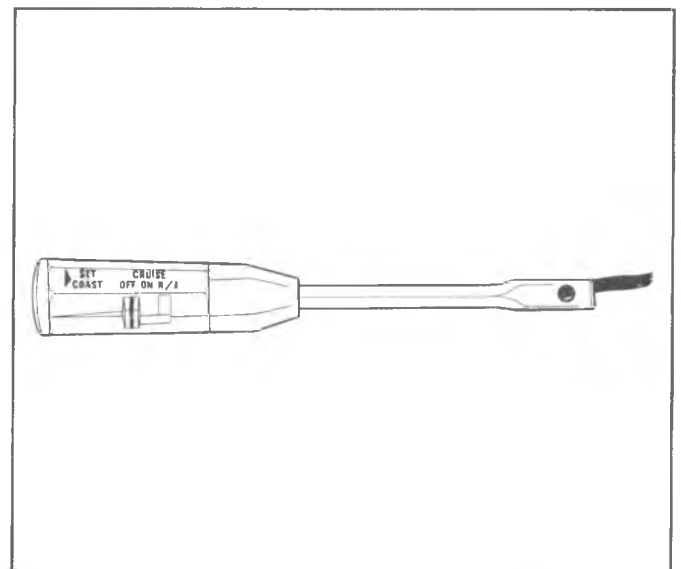

Fig. 9-2 — Mode Control Switches On Turn Signal Lever—CK Truck Models

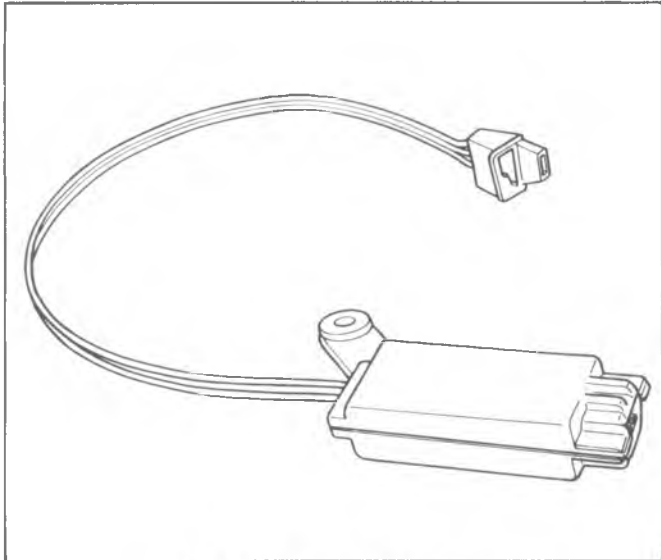

Fig. 9-3--VSS Buffer Amplifier

depressing and holding the **SET-COAST BUTTON** on the end of the turn signal lever until the vehicle "coasts down" to the desired speed. Vehicle speed at the moment of **SET-COAST BUTTON** release is the new set cruise speed. The accelerate function can be operated in either the cruise or non-cruise modes. Momentary slider switch movement to the R/A position after an on-off cycle will appear as a "set" cruise speed function.

## SYSTEM COMPONENTS

### GENERAL

The Custom Cruise 111 system consists of mode control switches, a controller, servo unit, speed sensor, vacuum supply, brake electrical release switch, a brake vacuum release valve, when used, a combination vacuum release valve/converter clutch switch, vacuum hoses and an electrical harness.

Some specific system components are:

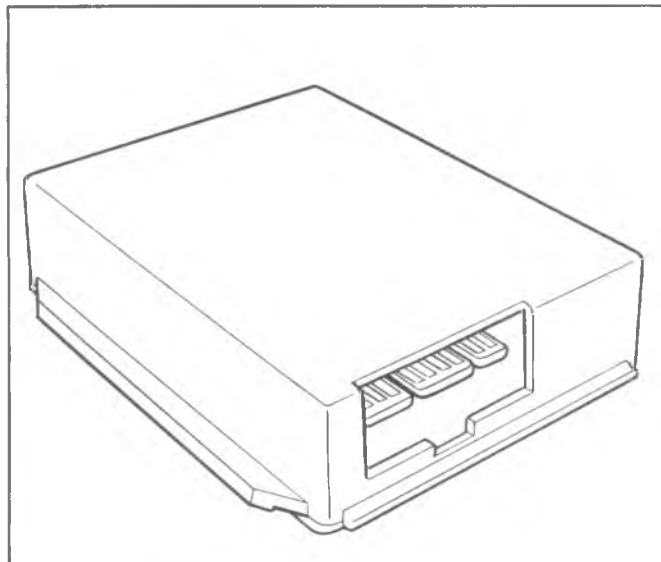

Fig. 9-4--Electronic Controller

### Custom Cruise 111

- **Speed Sensor:** VSS ( Vehicle Speed Sensor) Buffer Amplifier is connected to the speedometer to "sense " vehicle speed.
- **Servo Connection:** A Harness Adapter assembly interconnects the wiring harness to the servo unit on most applications.
- **Electronic Controller:** Separately mounted under the instrument panel, usually on the brake pedal bracket. Electronically responds to the servo position, mode control switch, brake (and clutch) pedal action for cruise operation.

### COMPONENT FUNCTIONS

**Mode Control Switches** - The various operating modes of the Custom Cruise 111 system are controlled by means of the Mode Control Switches normally located on the turn signal lever (Figures 9-1, 9-2).

**VSS Buffer Amplifier** - Vehicle speed information is "transduced" to the Electronic Controller by a speed sensor, (a Vehicle Speed Sensor (VSS) Buffer Amplifier). See Fig. 9-3. The output of the VSS Buffer Amplifier is a frequency proportional to vehicle speed. The signal is a 12-volt square wave with a repetition rate of 2002 pulses per mile.

**Electronic Controller** - The Electronic Controller (Fig. 9-4) contains a digital integrated circuit and supporting analog circuits. The controller interprets the position of the servo unit, the position of the mode control switches and the output of the speed sensor. In response to these inputs, the controller electrically signals the opening or closing of the vent and vacuum solenoid valves in the servo unit (See Fig. 9-4).

In Custom Cruise 111 applications, the Electronic Controller shown in Fig. 9-4 is usually mounted on the brake pedal bracket or some other structural component.

**Vacuum Release Valve** - The Vacuum Release Valve (Fig. 9-5) provides an additional vent for the servo unit to the atmosphere when the brake pedal is held in a depressed position. The "venting" action is spring actuated when the brake pedal is depressed and occurs within the "free-travel" of the brake pedal arm.

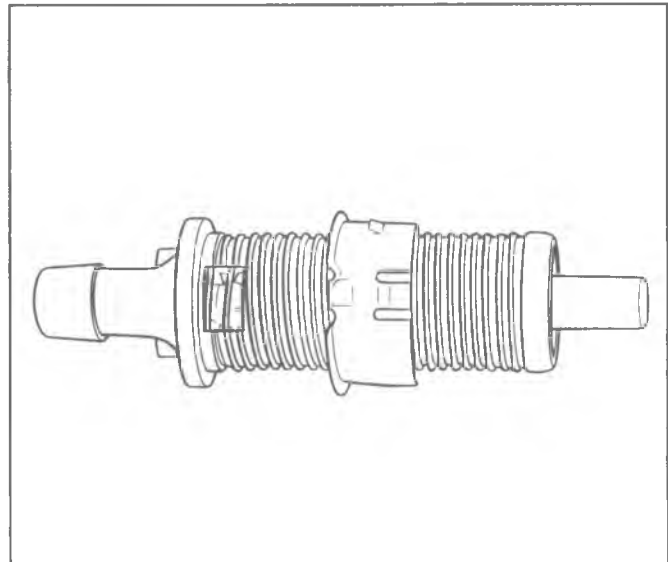

Fig. 9-5--Vacuum Release Valve

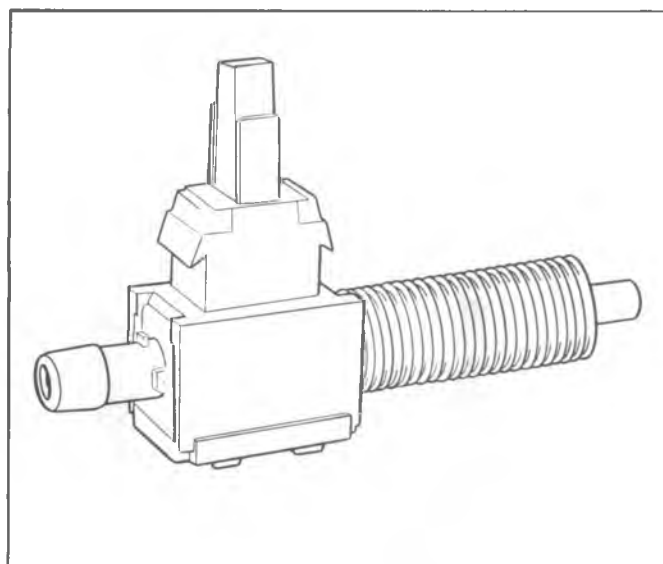

Fig. 9-6--Combination Vacuum Release Valve/Converter Clutch Switch

**Combination Vacuum Release Valve/Converter Clutch Switch** - Vehicles equipped with a lock-up torque converter (locking clutch) transmission use a Combination Vacuum Release Valve/Converter Clutch Switch (Fig. 9-6). The Vacuum Release Valve provides an additional vent for the servo unit to the atmosphere when the brake pedal is held in a depressed position. This "venting" action is spring actuated when the brake pedal is depressed and occurs within the "free-travel" of the brake pedal arm. At the same time, the contacts in the Converter Clutch Switch open, which disengages the locking clutch mechanism in the transmission.

**Combination Cruise/Stop Light Switch** - The Combination Cruise/Stop Light Switch (Fig. 9-7) is used with a separately mounted vacuum release valve. When the brake pedal is depressed, the switch illuminates the stop lights and also reverts the cruise function to a non-cruise condition. One set of electrical contacts operate the stop light, the other set operates the cruise release function.

**Clutch Switch** - On vehicles with manual transmissions, an electric Clutch Switch (Fig. 9-8) is used. Depressing

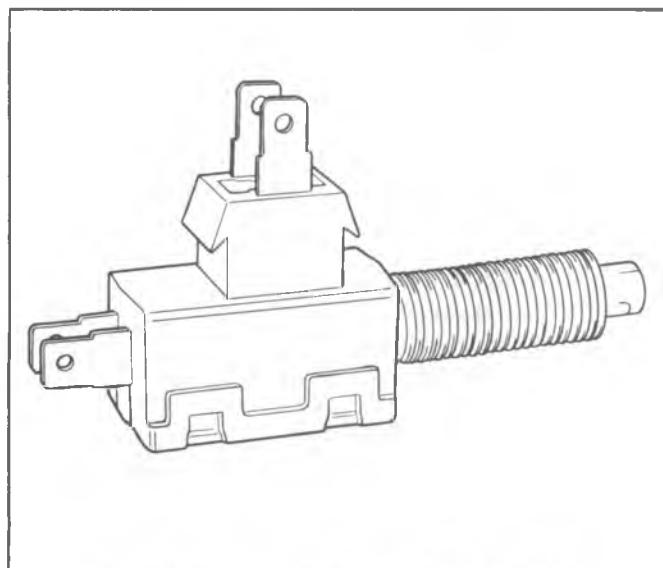

Fig. 9-7--Combination Cruise/Stop Light Switch

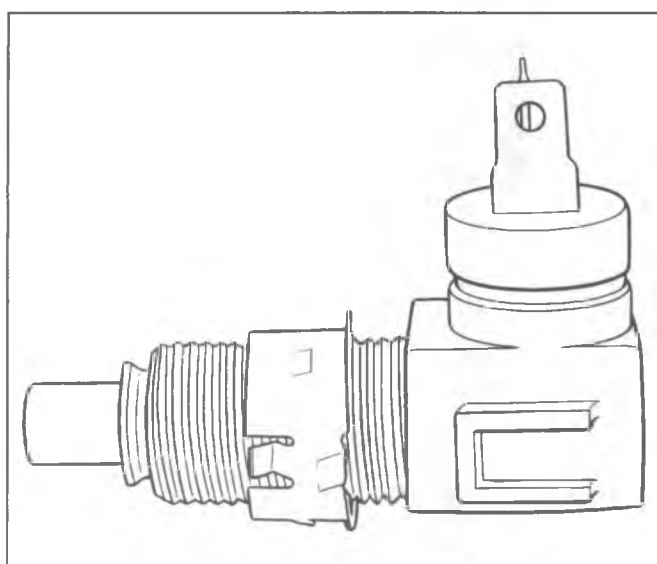

Fig. 9-8--Typical Clutch Switch

the clutch for up or downshifting a manual transmission disconnects the cruise function and throttle positioning by the servo unit. The cruise function remains disengaged after the clutch pedal is released.

**Vacuum Accumulator** - For acceptable cruise performance in vehicles with low manifold vacuum at road load, a Vacuum Accumulator (Fig. 9-9) is used. The Accumulator is attached to the intake manifold through a check valve and "stores" the high vacuum level that is available during periods of low engine loading. In use, the system operates on accumulator vacuum which is usually higher than manifold vacuum. It falls below manifold vacuum only when being charged by a high engine vacuum condition.

**The Vacuum Accumulator is not used with diesel engines.**

**SERVO Unit** - The Servo (Fig. 9-10) consists of a vacuum operated diaphragm, a normally open solenoid valve to vent the diaphragm chamber to atmosphere, a normally closed solenoid valve to connect the diaphragm chamber to the vacuum source, and a variable inductance position sensor. The servo operates the throttle in response to signals from the electronic controller as follow:

- **Steady State Cruise Function** - Both vacuum and vent valves are closed or sealed. The servo has a constant vacuum on the diaphragm and places no-flow requirements on the vacuum source.
- **Vehicle Losing Speed** - The controller energizes the vacuum solenoid to open the vacuum valve to the vacuum source. This increases the vacuum level in the servo to increase the throttle angle, the vent remains closed.
- **Vehicle Gaining Speed** - The controller de-energizes the vent solenoid to open the vent valve to the atmosphere which reduces vacuum in the servo and allows the throttle return spring to decrease the throttle angle, the vacuum valve remains closed.

**Harness Assembly** - The Harness Assembly (Fig. 9-11) contains electrical distribution wiring and vacuum hose to interconnect the major components of the Custom Cruise 111 system.

**Harness Adapter** - The Harness Adapter (Fig. 9-12) is



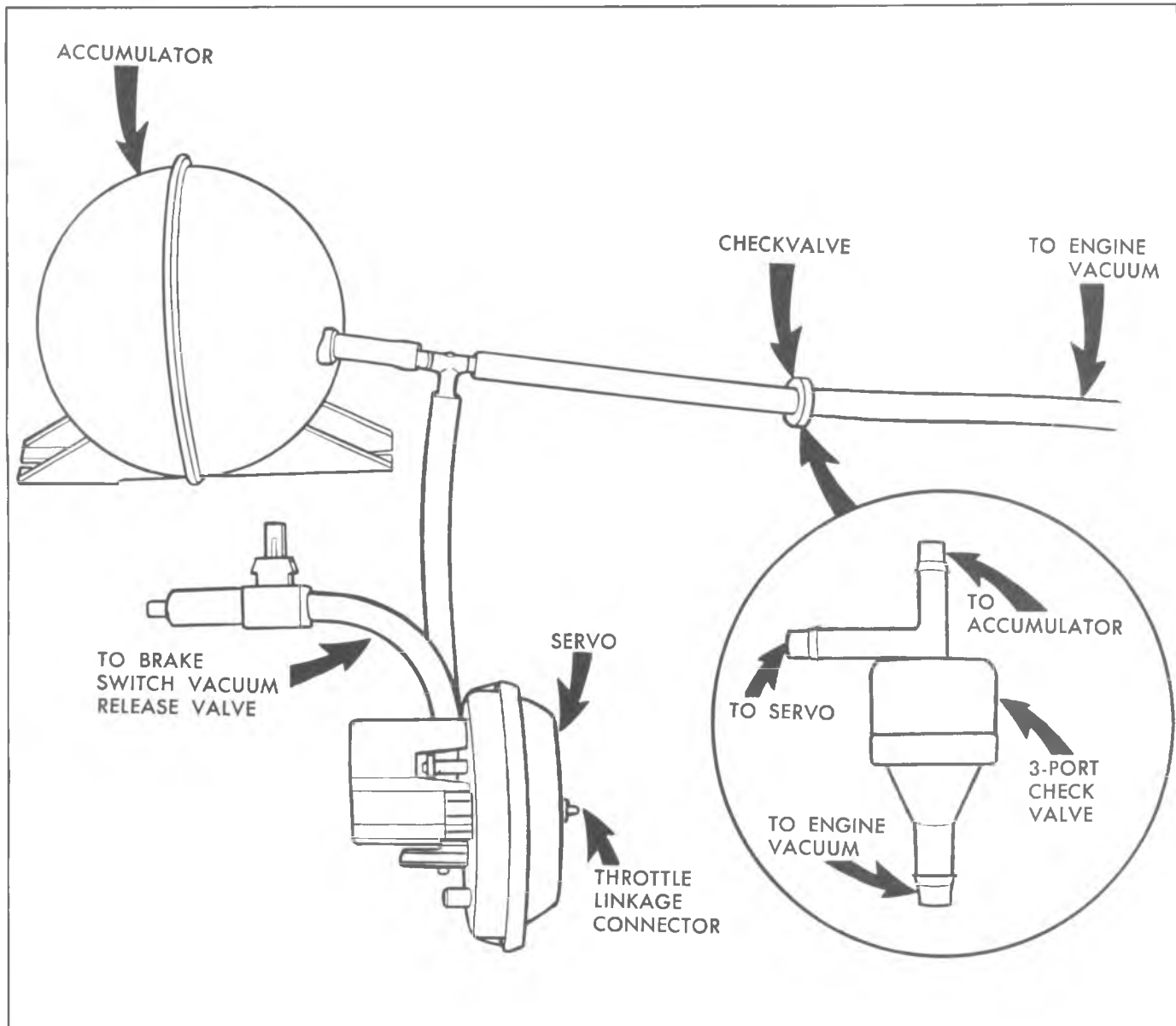

Fig. 9-9--Typical Pneumatic System Including Vacuum Accumulator.

used on some Custom Cruise 111 applications to connect the Harness Assembly to the Servo Unit when the bulkhead or "front-of-dash" hole is too small to accommodate the servo connector.

### Electrical/Vacuum System Operation

FIG. 9-13 is a block diagram illustrating component relationship in the Custom Cruise 111 system.

The servo vent solenoid valve and servo vacuum solenoid valve control the vacuum level in the servo in response to information from the electronic controller. The servo, in turn, controls the throttle position.

The electronic controller receives input signals from the mode control switches, brake release switch, speedometer buffer amplifier and a feedback signal from the servo position sensor.

### Custom Cruise 111 System

The Custom Cruise 111 system is illustrated in Fig. 9-14. Note that the Electronic Controller is a self-contained

assembly, usually located under the dash or on the brake pedal bracket or some other structural member. The speed signal which is generated by the speedometer is amplified by the vehicle speed sensor (VSS) buffer amplifier. Also shown is the Harness Adapter connection at the Servo.

### CUSTOM CRUISE 111 SYSTEM DIAGNOSIS

#### Controller and Related Circuit Operation

Refer to the electrical schematic diagram (Fig. 9-15).

#### MODE CONTROL SWITCH

- With the Mode Control slider switch in the "on" position and clutch and brake switch closed, battery voltage is available to the brake terminal "C" of the controller.
- With the slider switch in the "on" position, battery voltage is available at the cruise "on/off" terminal "K" of the controller.
- When the R/A (Resume/Accelerate) switch is

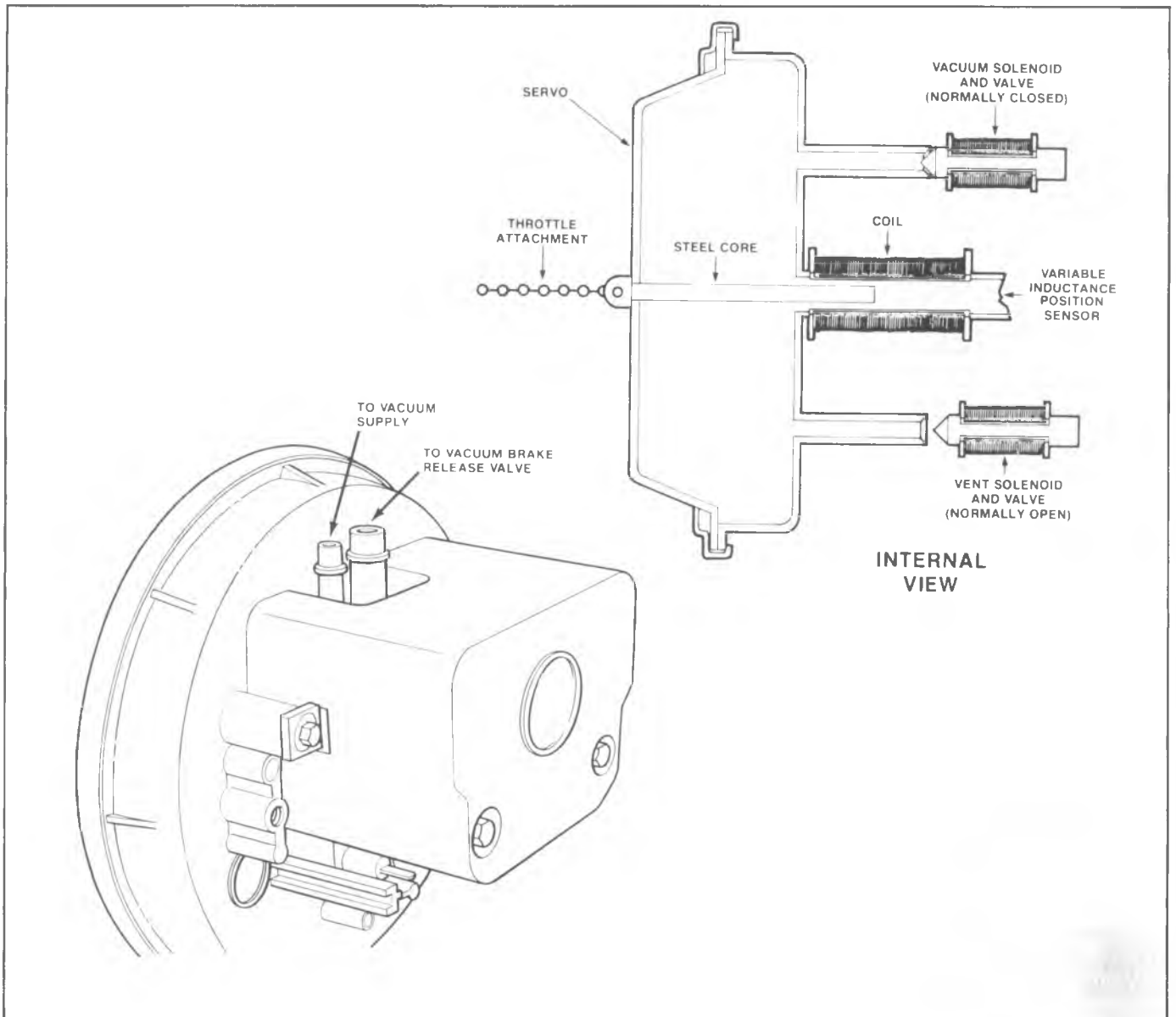

Fig. 9-10--Servo Unit and Operating Electro-Mechanism

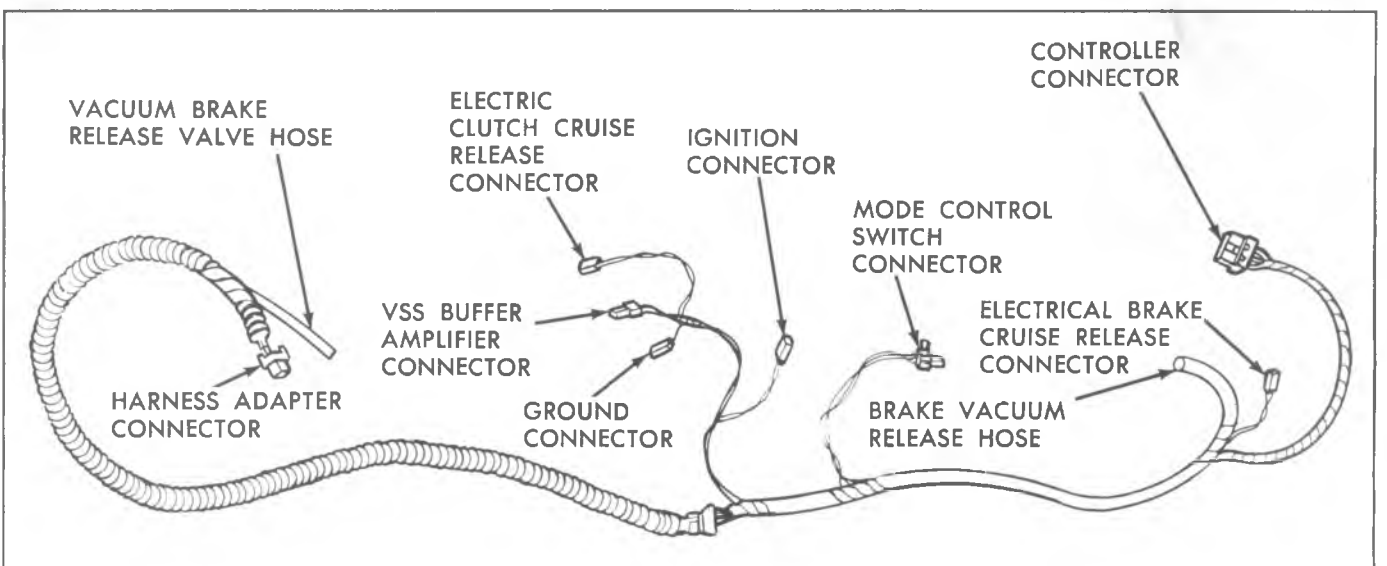

Fig. 9-11--Harness Assembly

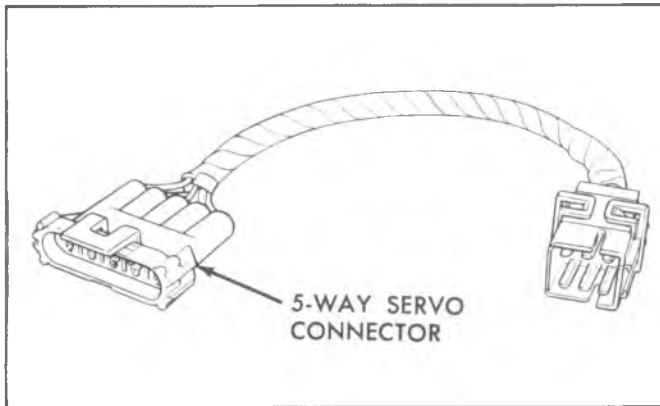

Fig. 9-12--Harness Adapter

momentarily on, battery voltage is present at the "Resume/Accelerate" terminal "H" of the controller.

- When the S/C (Set/Coast) switch is in the momentary on position, voltage is present, "Set/Coast" terminal "G" of the controller.

**SERVO UNIT**

- Terminals "B" and "D" monitor throttle position and route this information to (Servo Position Sensor) terminals "SPS HI" and "SPS LO" of the controller.
- Terminals "A" and/or "E" receive a vacuum or vent pulse, as determined by the controller to maintain the desired position.
- Terminal "C" is the ground terminal for the vent and vacuum valve solenoids.

**SPEED SENSOR**

- The signal generated at the Buffer Amplifier is fed to the speed sender terminal "S" of the controller.

**Preliminary Inspection**

In resolving any cruise system operating problem, first make a visual inspection. Check the system to ensure there are no bare, broken or disconnected wires or any pinched, damaged, or disconnected vacuum hoses. The servo and throttle linkage should operate freely and smoothly. The servo linkage should be properly adjusted. If the visual inspection does not reveal any abnormalities, the following tests are required. In the order listed until defect is corrected.

**TEST PROCEDURES**

**Cruise System Inoperative**

1. Check the brake/clutch switch - Disconnect brake and clutch switch.

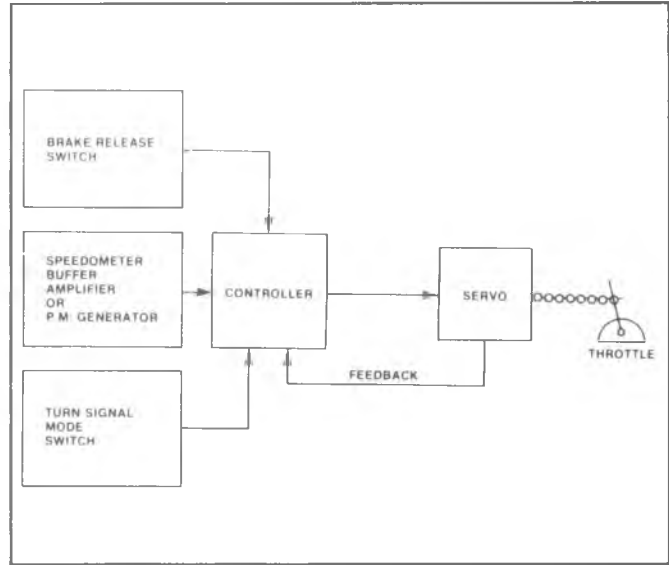

Fig. 9-13--Block Diagram

- a. Check continuity with pedals in the "free" position.
- b. If continuity shows an open, adjust or replace the brake/clutch switch as necessary.
2. Check the vacuum release valve and the combination vacuum release valve/converter clutch switch for vacuum operation.
  - a. If leaking, replace. If misadjusted, adjust.
3. Servo Check (See Figure 9-16) - Disconnect the electrical connector at the servo. Make sure the connector and connector pins are free of corrosion.
  - a. Check the resistance of the servo unit. Tolerances are:
    - A-C: 42 ..... 10 Ohms
    - E-C: 42 ..... 10 Ohms
    - B-D: 22 ..... 5 Ohms
  - b. If not in tolerance, replace the servo unit.
4. Turn off the ignition switch, then disconnect the body harness connector from the VSS Buffer Amplifier.
5. Connect Speedometer Signal Generator, J-33431 (Fig. 9-17) to the VSS Buffer Amplifier connector. Use the test set connectors provided with signal generator.
6. Disconnect the servo throttle linkage at the servo unit.
7. For Custom Cruise 111 installations, set the signal generator to the 54 mph and 30 Hz square wave position.

Speedometer Signal Generator J-33431 features other test capabilities. Use the signal generator only as described in Steps 5, 6 and 7.

8. Start the engine and move the Mode Switch slider to the "on" position.

| Test | Action   | Reaction   |
|------|--|--|
| 8a.  | Depress and release set coast switch (S/C).  | Servo will pull to approximately 28 to 42% of servo position travel and hold.  |
| 8b.  | Move cruise lever slider to Resume Accelerate (R/A) and hold for 3 seconds.<br>Release slider. | Servo will pull to the full stroke travel position and hold.<br>After releasing slider from the R/A position, the servo will return to 28 to 42% of the travel position. |
| 8c.  | Depress brake and/or clutch pedal.   | Servo will move to the zero degree travel position.  |
| 8d.  | Momentarily move cruise lever slider to Resume/Accelerate (R/A) position.                      | Servo will pull to the 28 to 42% position of travel and hold.  |

**NOTES:**

- Tests 8a, 8b, 8c, 8d are a functional test of the brake and clutch switches, servo, mode control switch, and electronic controller.
- If tests 8a, 8b, 8c and 8d meet specifications, a Buffer Amplifier or PM Generator defect is indicated.
- If tests 8a, 8b, 8c and 8d do not meet specifications, first check the harness to the controller for defects. Then make the following electrical check, Step 9 and a pneumatic check, Step 10, if required.

9. Electrical Check

- Check fuse.
- Check chassis ground and harness, as per Fig. 9-16. Perform ohmmeter checks on the harness between the controller and servo.
- Check the Mode Control Switches by replacing and rechecking with a known good switch or as per Fig. 9-18.

d. Perform Step 10.

10. Pneumatic Check

- Disconnect the bead chain (or rod) and electrical connector at the servo unit.
- Start the engine.

| Test | Action   | Reaction   |
|------|--|--|
| 10c. | Apply 12 volts to A-C and E-C.<br>(A-C closes the normally open vent valve — E-C opens the normally closed vacuum valve)                     | Servo should full stroke. If not, check vacuum hoses to the vacuum supply.                   |
| 10d. | Remove voltage from E to C.  | The Servo should hold a full stroke, if not, go to the next step, 10e.                       |
| 10e. | Disconnect the vacuum brake release at the servo and plug the servo. Momentarily apply 12 volts to E to C to allow the servo to full stroke. | If the servo holds its position, adjust the brake vacuum release valve or replace the valve. |

11. If no defect is found, replace the electronic controller.

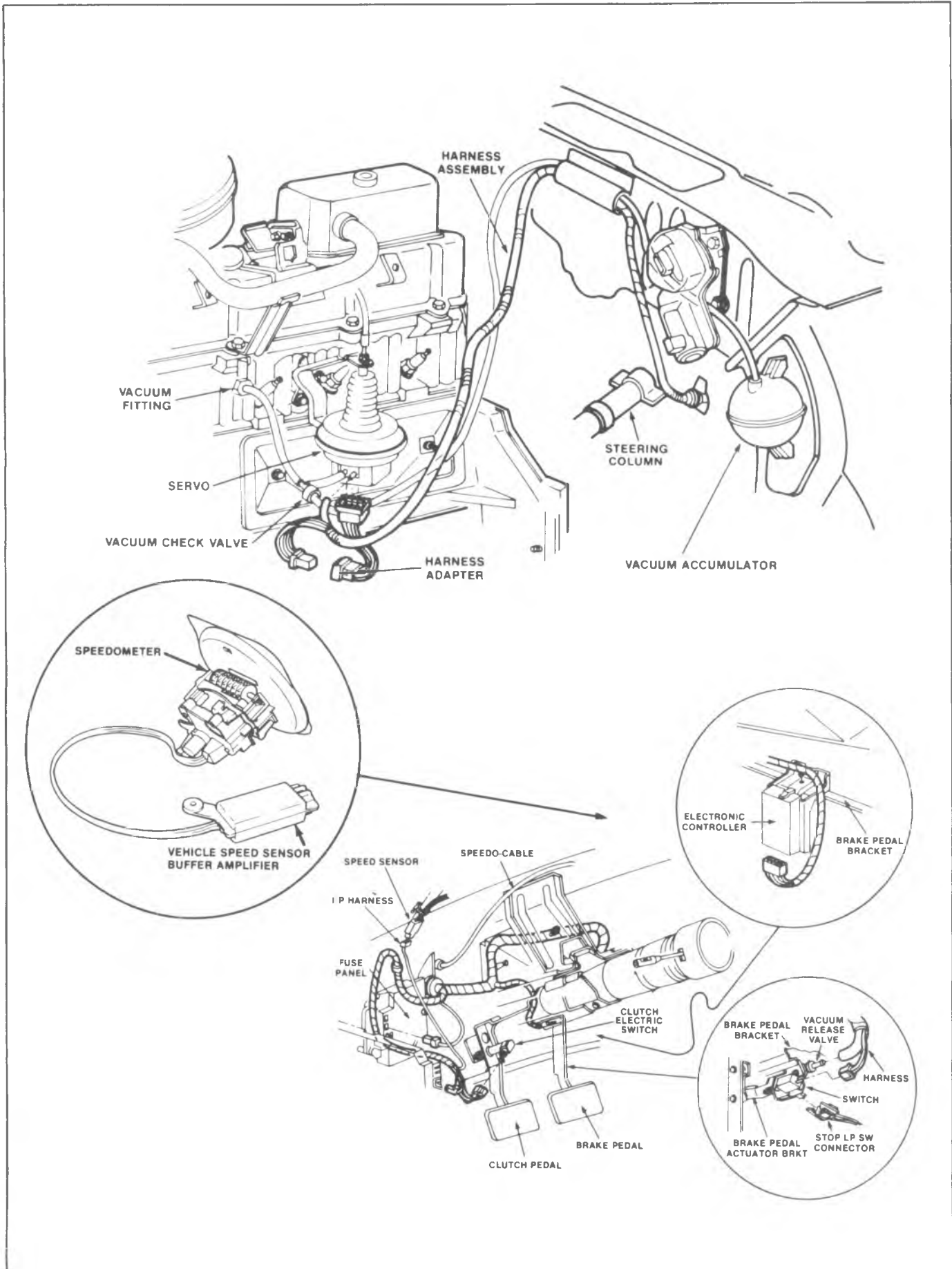
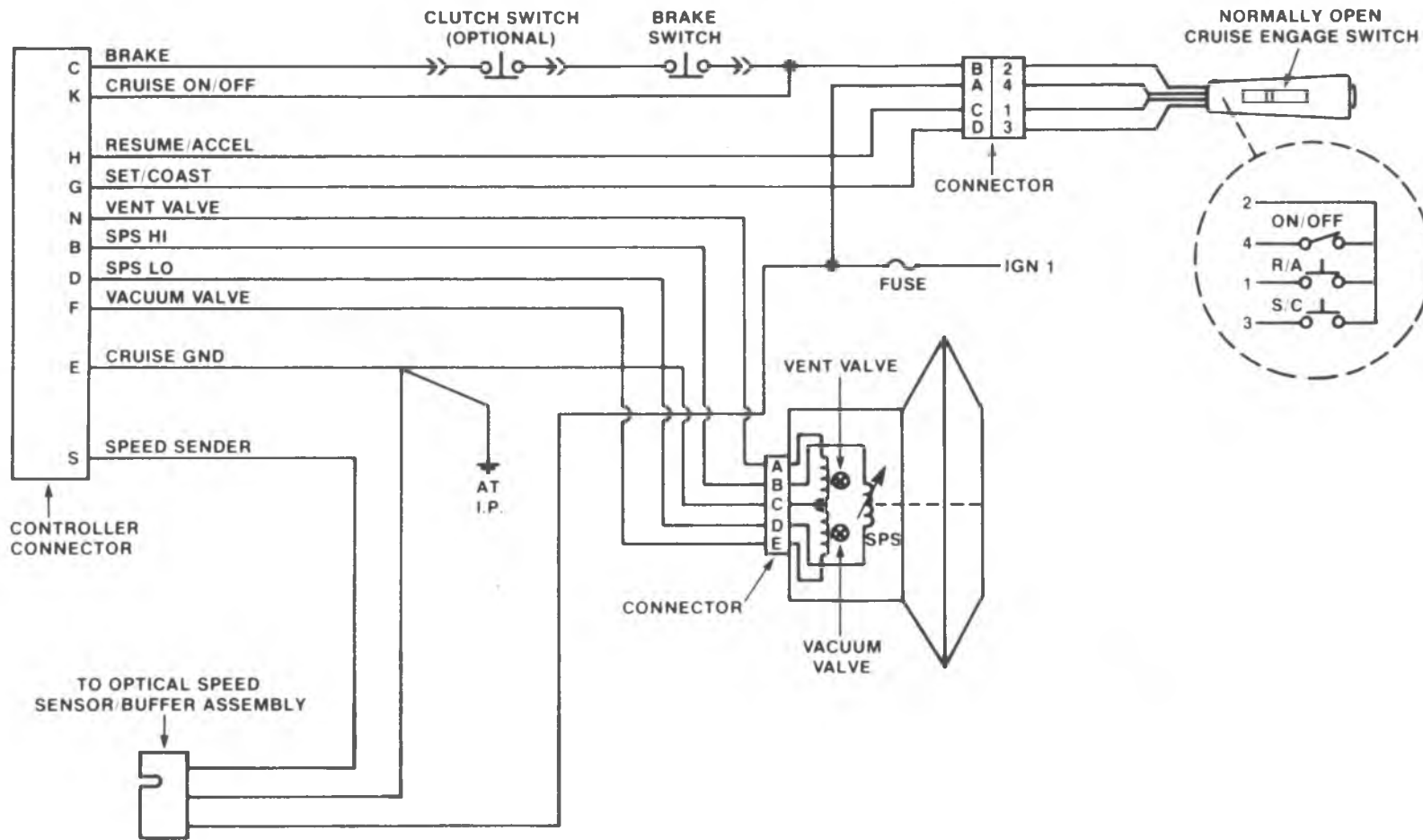

Fig. 9-14--Typical Installation-Custom Cruise 111 System

Fig. 9-15--Electrical Schematic, Custom Cruise 111 System



- NOTES
1. The harness used on 1983 California vehicles incorporates a special connector in the speed sender lead to provide signal data to the electronic control module.
  2. Controller terminal identification applies to 1983 models.

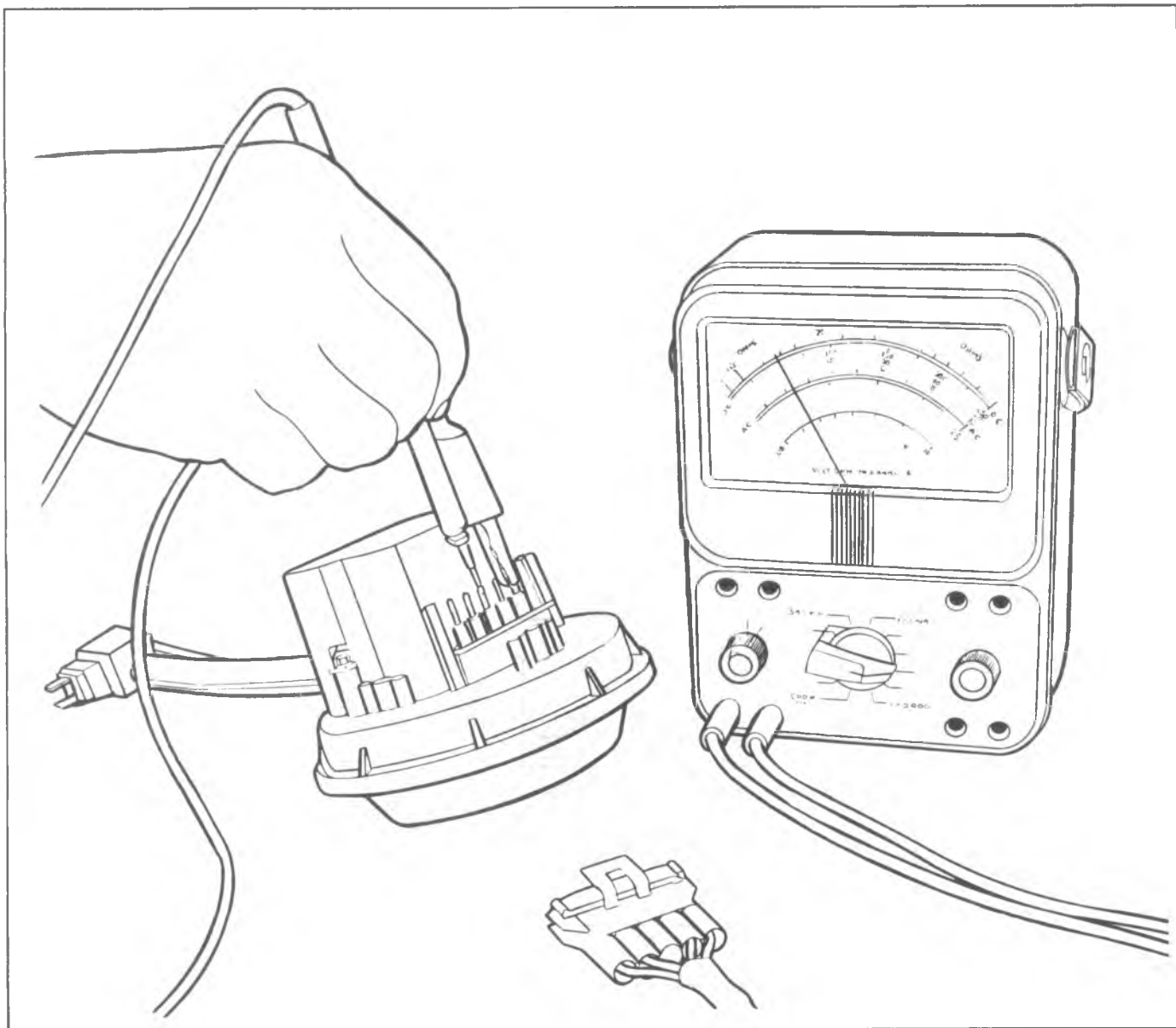

Fig. 9-16--Servo Resistance Measurement

### CRUISE SYSTEM SURGES

1. The servo and throttle linkage should operate freely and smoothly. Hoses should be properly routed with no restrictions or leaks.
2. Check the servo as per Steps 3, 8 and 10. Cruise System inoperative. Replace the servo if required.
3. If no system defect is noted, replace the electronic controller.

### CRUISE SET SPEED HIGH OR LOW

1. Check vacuum hoses for proper routing and for restrictions or leaks. Adjust or replace as required.
2. Check servo linkage for excess slack and adjust.
3. Replace the electronic controller.

### EXCESSIVE CRUISE SPEED LOSS ON HILLS

1. Check hoses for vacuum leaks.
2. Determine if check valve is functional.

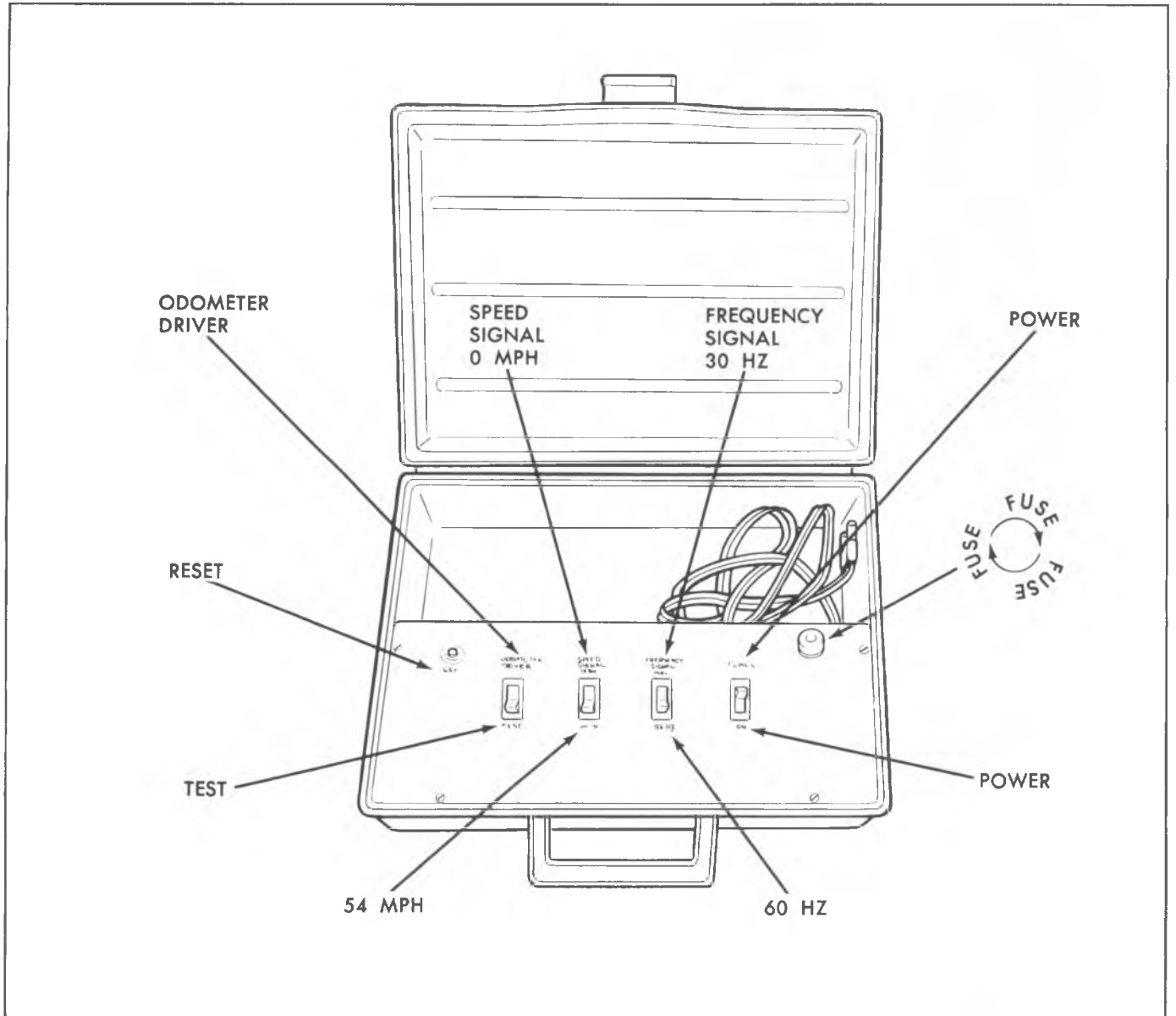

Fig. 9-17--Speedometer Signal Generator J-33431



| SET/COAST (S/C) SW | POSITION SLIDER | 1-2 | 1-3 | 1-4 | 2-3 | 2-4 | 3-4 |
|--------------------|-----------------|-----|-----|-----|-----|-----|-----|
| Normal             | Off             | O   | O   | O   | O   | O   | O   |
| Normal             | On              | O   | O   | O   | O   | C   | O   |
| Normal             | R/A             | C   | O   | C   | O   | C   | O   |
| Depressed          | Off             | O   | O   | O   | C   | O   | O   |
| Depressed          | On              | O   | O   | O   | C   | C   | C   |
| Depressed          | R/A             | C   | C   | C   | C   | C   | C   |

C — Closed

O — Open

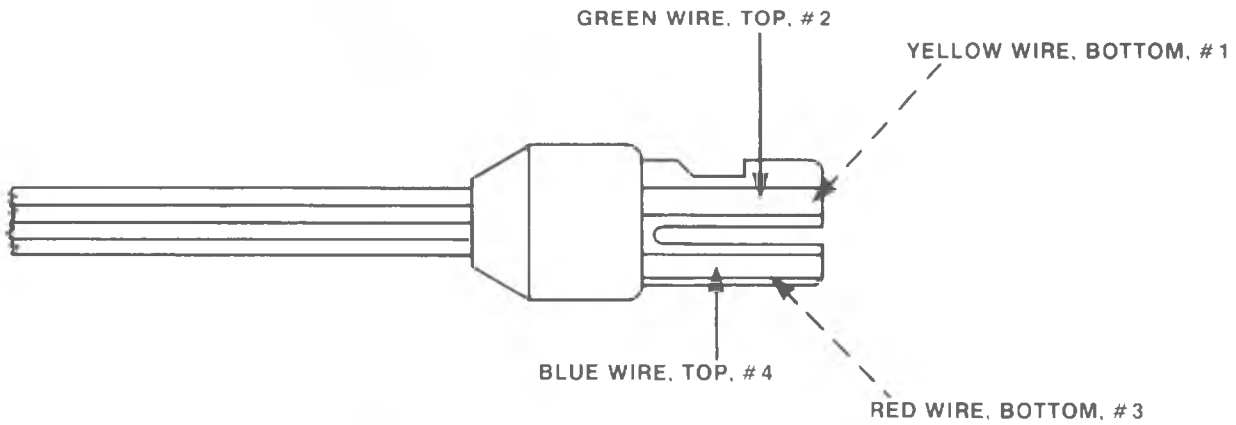
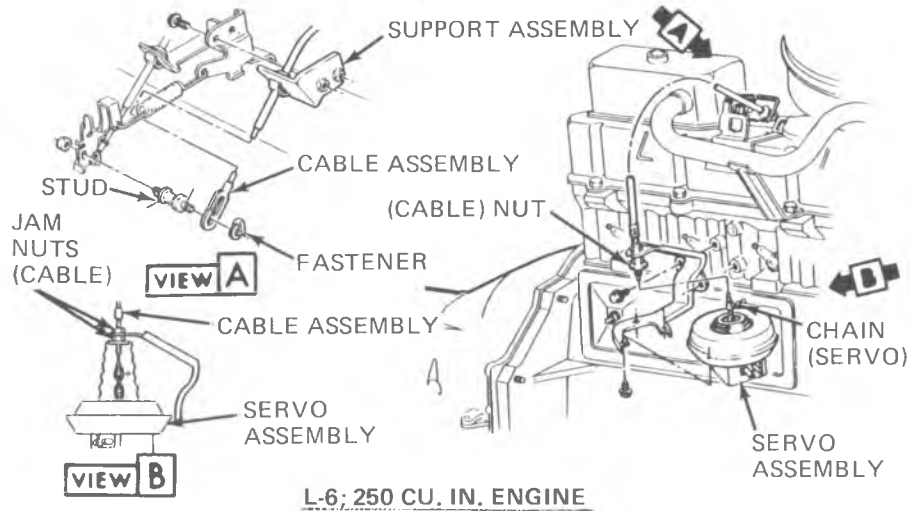

Fig. 9-18 — Mode Control Switch Electrical Check

### CRUISE CONTROL CABLE ADJUSTMENT

Using third ball only on servo chain, and with throttle completely closed (ignition off and fast idle cam off) adjust cable jam nuts until 1.0 mm clearance is between stud pin and end of slot. Tighten jam nuts.



L-6, 250 CU. IN. ENGINE

### SERVO ASSEMBLY TO CARBURETOR ADJUSTMENT

With ignition off and fast idle cam off and throttle completely closed, adjust length so that rod assembles over end of stud as shown (see View A). Install retainer.

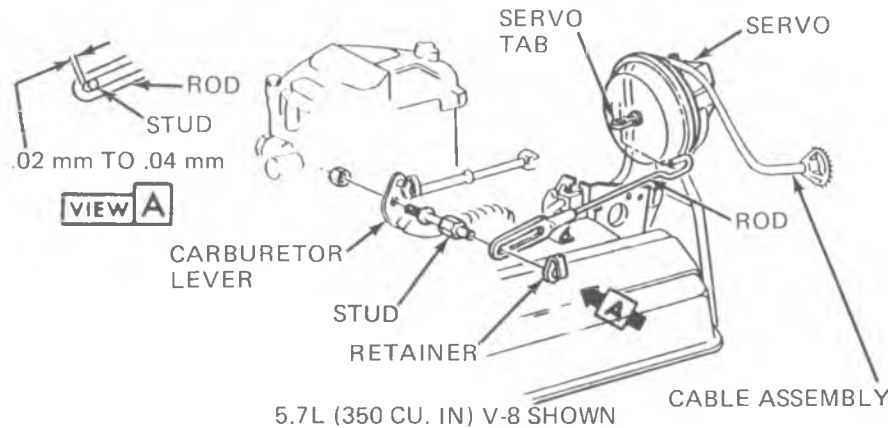

ALL V-8 GAS ENGINES

### CKG TRUCKS CRUISE CONTROL SERVO ADJUSTMENT

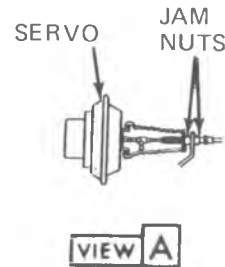

L-6, 4.8L (292 CU. IN.) ENGINE

### CRUISE CONTROL CABLE ADJUSTMENT

With cable assembly installed and using second ball only on servo assembly chain, install servo assembly chain on cable assembly (see View A). With throttle completely closed (ignition and fast idle cam off) adjust cable assembly jam nuts until 1.0 mm clearance is between lever pin and end of cable assembly slot. Tighten cable assembly jam nuts.

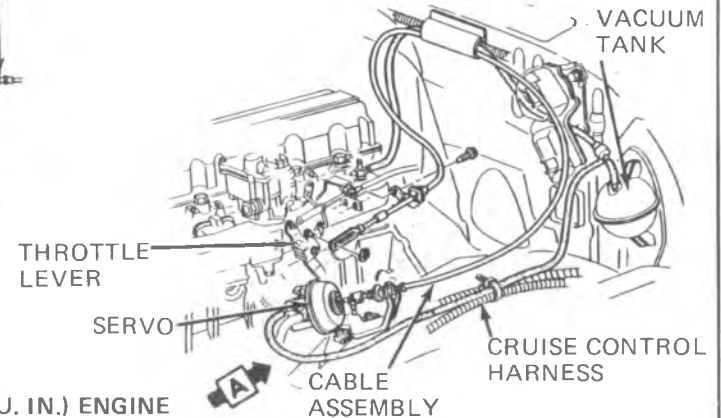

### SERVO ASSEMBLY ROD LINK ADJUSTMENT

With engine not running and idle screw against stop, assemble lower end of rod link to throttle lever and upper end to hole closest to servo which will provide a minimum of 1.0 mm slack. See View C.

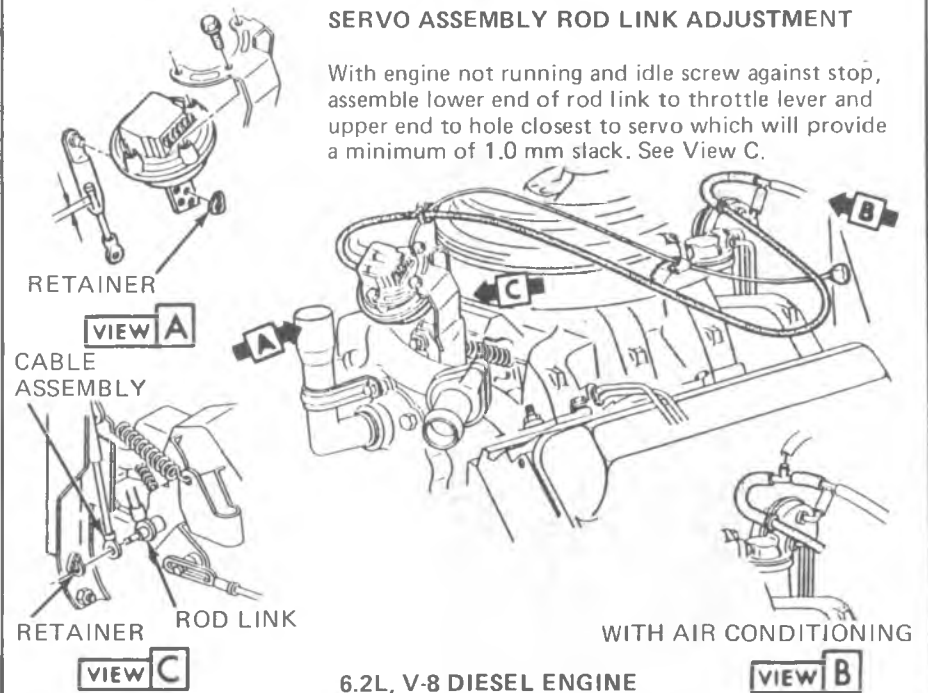

6.2L, V-8 DIESEL ENGINE

## RADIO

### GENERAL DESCRIPTION

Six types of radios are available: AM Pushbutton, AM/Stereo 8-Track Tape, AM/FM, AM/FM Stereo, AM/FM Stereo/Stereo tape, and AM/FM Stereo Cassette Tape. The left knob operates the on-off switch and volume control, the left ring operates the tone control. The right hand knob controls manual tuning. All AM/FM radios have five push buttons (10 station selections) five on AM and five on FM.

On models equipped with auxiliary speakers, a variable control located behind the manual tuning knob adjusts the

volume of the front and rear speakers. Turn the control clockwise to increase rear speaker volume and decrease front speaker volume. Turn the control counterclockwise and the rear speaker volume decreases and the front speaker volume increases. Both speakers are controlled together by the volume control knob.

On models equipped with stereo radios, this control varies front and rear speaker volume to obtain the desired balance for stereo separation.

## DIAGNOSIS

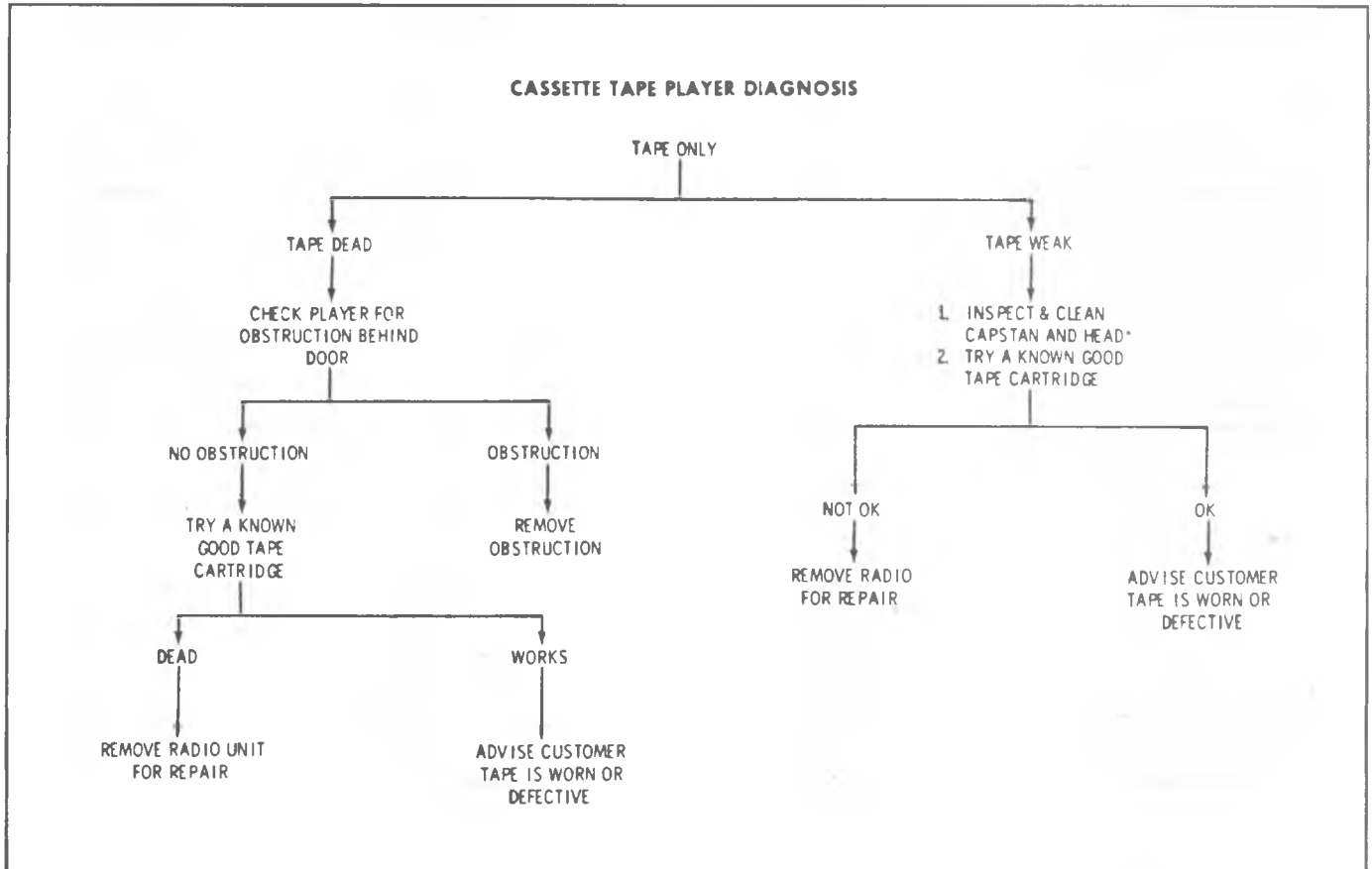

Fig. 9-1R--Cassette Tape Player Diagnosis

### CASSETTE TAPE PLAYER DIAGNOSIS

Diagnosis of radio portion of cassette-AM/FM is shown on the diagnosis charts. For cassette diagnosis, refer to Fig. 9-1R. If unit must be removed, it must be repaired by an authorized service station. See Section 8 for removal procedures and connections for speaker and power wiring.

### EIGHT-TRACK STEREO TAPE DIAGNOSIS

The tape player trouble diagnosis guide is intended as an aid in locating minor faults which can be corrected without a specialized knowledge of electronics and without special test equipment. If the suggestions given here do not effect a correction, further testing should be done only by a trained radio technician having proper test equipment. It should first be determined if the owner's tape and not the player is at fault. Substituting a known good tape cartridge for the owner's is a simple check.

Because tape player service problems are generally corrected by a radio repair shop, there is a tendency for many technicians to remove a set when a problem is reported. Removal of the tape player can frequently be avoided if the diagnosis chart is used to eliminate problems which can be easily fixed or which are not caused by a faulty player.

In diagnosing radio/tape problems the main point to remember is that you now have both a radio and a tape player to diagnose as part of the stereo system. By inserting test tape, J-22683-01, you can quickly determine whether

the tape speed is proper. Since only the pre-amps and audio are common to both radio and tape, by listening for distortion with the tape playing and comparing it to the radio signal, you can further isolate the problem to either radio or tape; See the Diagnosis Chart.

### STATIC AND NOISE DIAGNOSIS

Refer to figure 9-3R for radio static suppression on the vehicle. Ground strap connections must be clean and tight, spark plug cables must be TVRS type and in good condition and resistance type spark plugs used. Extra electrical equipment added to the car could cause static if not properly grounded or wiring was improperly routed. Radio and antenna lead-in grounding must be clean and tight. An improperly trimmed antenna adjusting screw could result in poor sensitivity and static/noise on AM stations only.

Weak FM station reception will be affected by near-by buildings, car speed, direction and windshield wiper operation. These "flutter," "swish" and "fading" conditions are characteristics of weak FM signals.

### POPPING NOISE DIAGNOSIS

Operating switches such as turn signal, pushing in cigarette lighter, operating stop lights, etc., may cause a popping noise on distant AM (weak) signals. Adjusting the antenna trimmer, if it is out of adjustment, will minimize the noise.

### TESTING WINDSHIELD ANTENNA (Fig. 9-4R)

All C-K model trucks with factory installed radios are

## DIAGNOSIS AM/FM-CB RADIO COMBINATION

| PROBLEM   | CHECK                          | ACTION                                     |
|---|--------------------------------|--|
| No AM, FM or CB sound<br>No CB channel display.                   | Check Fuse                     | Remove radio for repair.                   |
| No AM, FM or CB sound<br>Channel display OK                       | Mode Switch<br>Squelch control | Remove radio for repair                    |
| No AM, or FM sound;<br>CB sound OK                                | Mode switch<br>Squelch         | Remove radio for repair                    |
| No CB sound and no channel<br>display; AM/FM sound OK             | Mode switch                    | Remove radio for repair                    |
| No CB sound, channel display<br>OK; AM/FM OK.                     | Mode switch<br>Squelch         | Replace antenna<br>Remove radio for repair |
| Irregular channel stepping &<br>unit not coordinated with display | Cable connections              | Remove radio for repair                    |
| Display segments missing or<br>segment contrast not uniform       | Mode switch                    | Remove radio for repair                    |
| Channel display won't change                                      | Selector switch                | Remove radio for repair                    |
| Channel display indicates only "O"                                | Power connector                | Remove radio for repair                    |

Fig. 9-2R--AM/FM-CB Radio Diagnosis

equipped with windshield antennas. To positively identify antenna failure and eliminate the possibility of unnecessary windshield replacement, Windshield Antenna Tester J-23520 should be used to determine continuity of the thin antenna wire.

When antenna failure is suspected, the following checks should be made before replacing the windshield.

1. Check Tester J-23520 for operation on any vehicle radio antenna that is operating normally to test for a weak or dead battery.
2. Check all antenna connectings to insure that antenna is electrically coupled to the radio.
3. Turn ignition switch to accessory position, turn radio "ON", select AM band if receiver is AM/FM and tune radio to an off station position.
4. Hold tester to antenna beginning at the upper corner of antenna:

**NOTICE:** The plastic shield must be on tester at all times to avoid scratching windshield.

- a. If a shrill sound is emitted through the speaker when both antenna wires are tested, antenna is operational.
- b. If no sound is emitted through one or both antenna wires, move tester along the wire toward center of windshield and down toward radio.
- c. If a shrill sound is picked up, find exact location where the noise begins, this is the area of the defect. Replace windshield.
- d. If no noise is heard over entire length of antenna, unplug antenna lead at radio and touch tester to antenna socket in radio.
- e. If radio now makes a shrill sound, check connectors and antenna lead for possible defect before replacing windshield.
- f. If no noise is emitted, radio, speaker, or fuse is defective.

Make sure that antenna tester is turned off after completing antenna test.

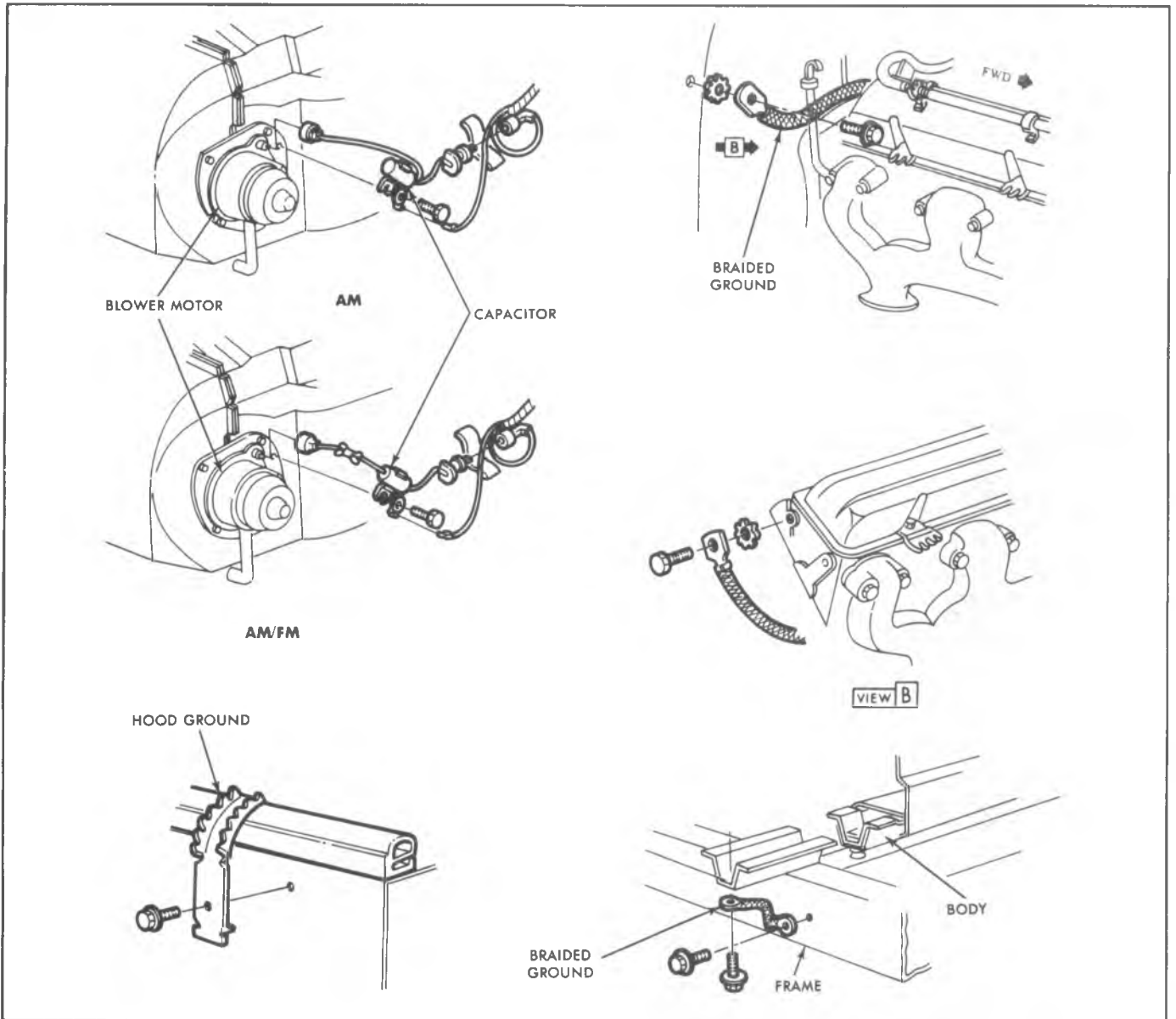

Fig. 9-3R--Radio Static Suppression--Typical

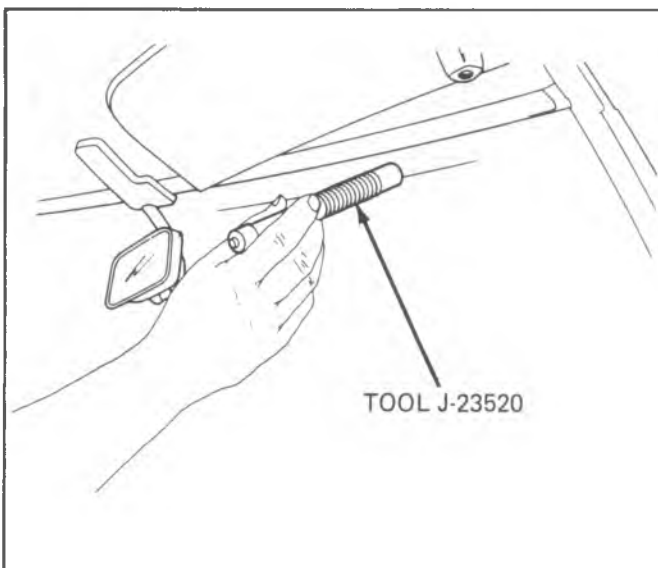

Fig. 9-4R--Testing Windshield Antenna (Typical)

### RADIO NOISE DIAGNOSIS IMPROPERLY OPERATING IGNITION SYSTEM (HEI)

START ENGINE AND LISTEN FOR TICKING SOUND OR NOISE PRODUCED BY THE ENGINE FIRING.

CHECK SPARK PLUG WIRES FOR DIRT AND CORROSION ON CONTACTS, BREAKS IN WIRES, AND LOOSE CONNECTIONS.

OK

NOT OK

CHECK FOR BROKEN CONTACT BUTTON ON ROTOR.

CORRECT OR REPLACE WIRES.

CHECK FOR WORN CONTACT SPRING ON ROTOR OR SPRING BINDING IN HOLDER.

REPLACE.

CHECK FOR POOR INDEXING OF ROTOR SPRING.

REPLACE.

CHECK FOR BAD DISTRIBUTOR CAP (CARBON ERODED).

REPLACE.

CHECK THAT CARBON CYLINDER IN DISTRIBUTOR CAP IS MOVING FREELY.

REPLACE.

CHECK FOR GREASE ON ROTOR.

CORRECT.

CHECK FOR LOOSE GROUND SCREW ON IGNITION MODULE.

CLEAN.

CHECK FOR LOOSE GROUND SCREW ON DISTRIBUTOR CONDENSER.

TIGHTEN.

TIGHTEN.

### LACK OF SHIELDING/GROUNDING

CHECK ENGINE TO BULKHEAD BOND.

OK

NOT OK

CHECK ANTENNA LEAD-IN SHIELD FOR LESS THAN 1 OHM RESISTANCE.

ADD CLIP OR GROND STRAP.

CHECK FOR A GOOD GROUND OF THE HOOD (HOOD GROUND CLIP).

REPLACE IF NECESSARY.

CHECK THAT WIPER HOSES ARE NON-CONDUCTIVE TYPE (BLACK WITH WHITE STRIPE).

CORRECT — USE OPTIONAL HOOD CLIP IF NECESSARY.

CHECK THAT ANTENNA (EXTERNAL MOUNT) MOUNTING NUT ON TOP OF FENDER IS TORQUED TO SPECIFICATION. ON A POWER ANTENNA, CHECK THAT ANTENNA LEAD-IN FITTING IS TORQUED TO SPECIFICATION AT THE ANTENNA. ALSO CHECK THAT LEAD-IN IS WELL GROUND (WINDSHIELD AND FENDER MOUNT).

REPLACE IF NECESSARY.

CONSULT APPLICABLE SERVICE BULLETINS (WHICH MAY BE RELEASED SUBSEQUENT TO THIS MANUAL), OR RADIO EXCHANGE/REPAIR CENTER.

TORQUE TO SPECIFICATION.

Fig. 9-5R--Radio Diagnosis, Chart A

**RADIO NOISE — BLOWER MOTOR**

TURN ON BLOWER MOTOR. NOISE APPEARS AS STATIC WHICH FOLLOWS BLOWER MOTOR SPEED (USUALLY ON FM).

CHECK IF A .25 MFD COAXIAL FEED-THROUGH CAPACITOR IS INSTALLED ON THE BLOWER MOTOR LEAD.

**INSTALLED**

**NOT INSTALLED**

SUBSTITUTE A .25 MFD COAXIAL CAPACITOR. (REFER TO "MAINTENANCE AND ADJUSTMENTS")

INSTALL A .25 MFD COAXIAL CAPACITOR. (REFER TO "MAINTENANCE AND ADJUSTMENTS")

**NO NOISE**

**NOISE**

**NO NOISE**

REPLACE CAPACITOR.

REPLACE BLOWER MOTOR.

STOP.

**TAPE ONLY**

**TAPE DEAD**

**TAPE WEAK**

CHECK PLAYER FOR OBSTRUCTION THROUGH DOOR.

INSPECT & CLEAN, MOVING PARTS AND HEAD\*

**NO OBSTRUCTION**

**OBSTRUCTION**

**TAPE NOT OK**

**TAPE OK**

SUBSTITUTE KNOWN GOOD TAPE CARTRIDGE

REMOVE OBSTRUCTION

SUBSTITUTE WITH KNOWN GOOD TAPE CARTRIDGE.

STOP

**DEAD**

**WORKS**

**SUBSTITUTE TAPE NOT OK**

**SUBSTITUTE TAPE OK**

REMOVE PLAYER

INFORM CUSTOMER TO USE GOOD QUALITY TAPES

REMOVE UNIT

INFORM CUSTOMER TO USE GOOD QUALITY TAPE

Fig. 9-6R--Radio Diagnosis, Chart B



**DEAD RADIO — AM RADIO**

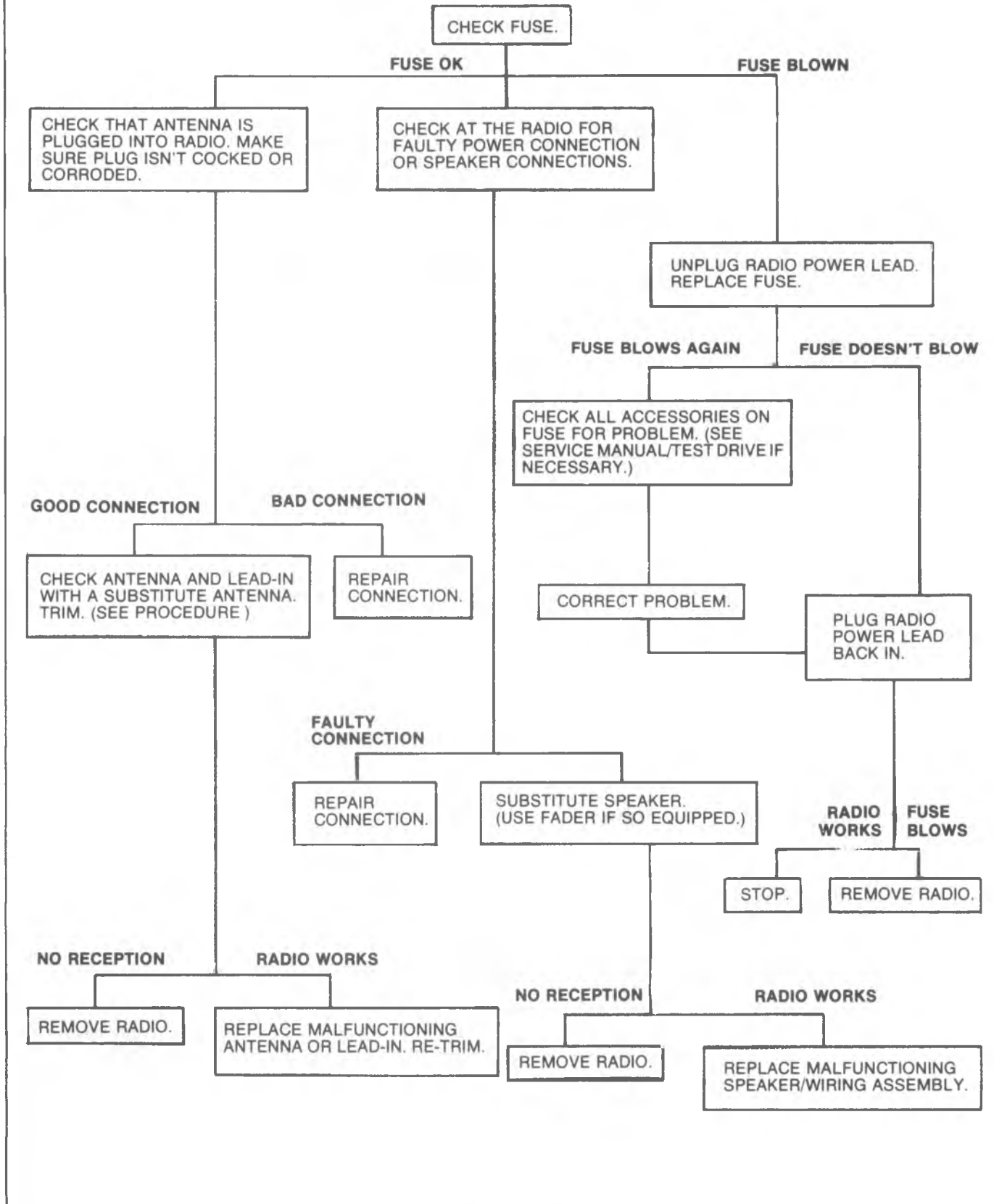

Fig. 9-7R--Radio Diagnosis, Chart C

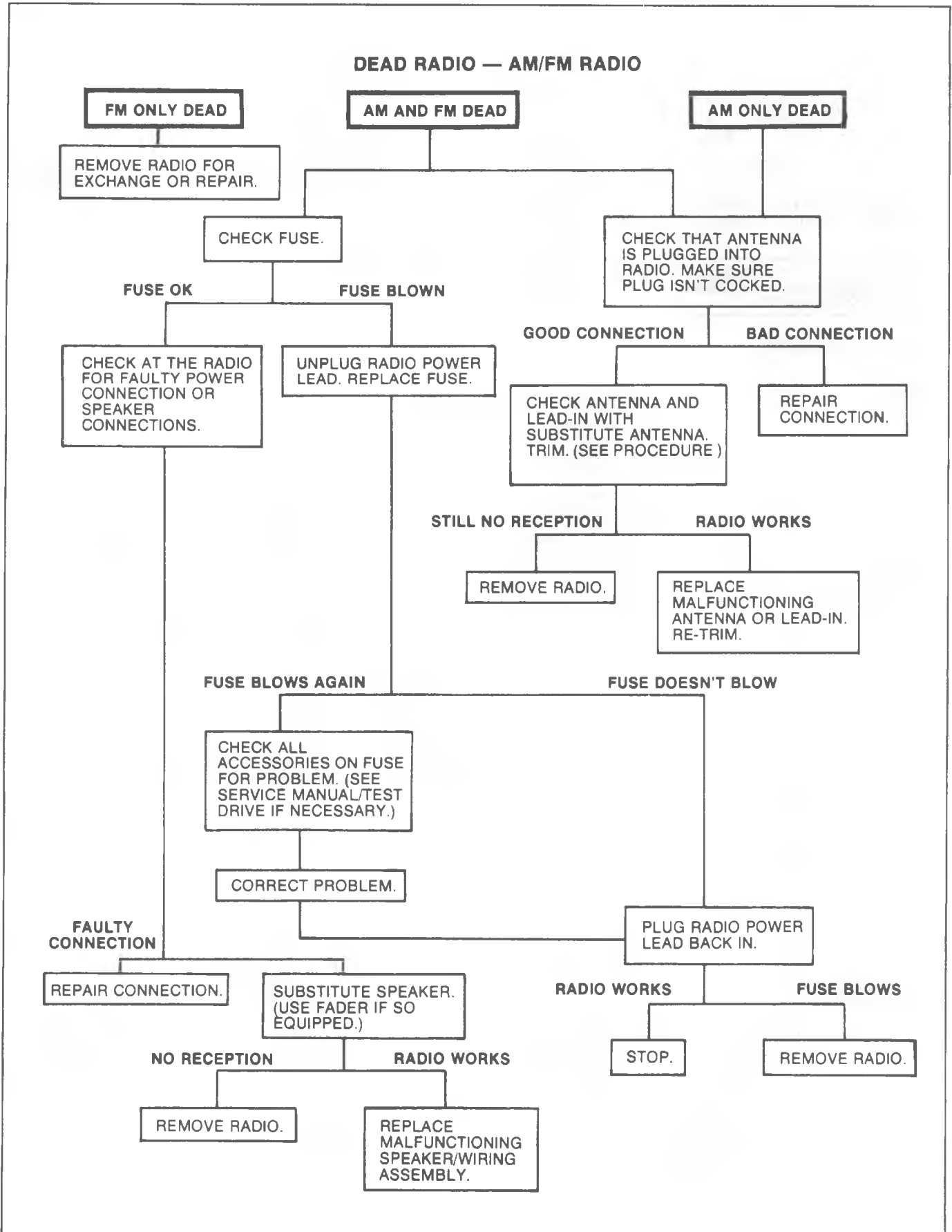

Fig. 9-8R--Radio Diagnosis, Chart D

**DEAD RADIO — AM/FM STEREO**

CHECK IF ALL SPEAKERS ARE DEAD  
(USE FADER TO CHECK.)

NO

YES

SUBSTITUTE BAD SPEAKER(S).

FM ONLY DEAD

AM AND FM DEAD

AM ONLY DEAD

SUBSTITUTE SPEAKER WORKS,  
BUT DEAD SPOT ON FADER\*

SUBSTITUTE SPEAKER  
DOES NOT WORK

REMOVE RADIO.

REPLACE MALFUNCTIONING  
SPEAKER/WIRING ASSEMBLY  
AND REMOVE RADIO.

REMOVE RADIO.

\*FADER DEAD SPOT:  
AS FADER IS ROTATED, A  
POSITION IS FOUND AT  
WHICH ONE OR TWO SPEAKERS  
SUDDENLY GO DEAD.

SUBSTITUTE SPEAKER WORKS  
AND NO DEAD SPOT ON FADER\*

REPLACE MALFUNCTIONING  
SPEAKER/WIRING ASSEMBLY.

CHECK FUSE

CHECK THAT ANTENNA IS  
PLUGGED IN TO RADIO. MAKE  
SURE PLUG ISN'T COCKED

FUSE OK

FUSE BLOWN

CHECK AT THE RADIO FOR  
FAULTY POWER CONNECTION  
OR SPEAKER CONNECTIONS.

UNPLUG RADIO POWER LEAD,  
REPLACE FUSE.

GOOD CONNECTION

BAD CONNECTION

CHECK ANTENNA AND LEAD IN  
WITH SUBSTITUTE ANTENNA.  
TRIM (SEE PROCEDURE )

REPAIR  
CONNECTION

STILL NO RECEPTION

RADIO WORKS

REMOVE RADIO

REPLACE MALFUNCTIONING  
ANTENNA OR LEAD IN.

FUSE BLOWS AGAIN

FUSE DOESN'T BLOW

CHECK ALL ACCESSORIES ON  
FUSE FOR PROBLEM (SEE  
SERVICE MANUAL/TEST DRIVE IF  
NECESSARY)

CORRECT PROBLEM

PLUG RADIO  
POWER LEAD  
BACK IN.

FAULTY  
CONNECTION

RADIO WORKS

FUSE BLOWS

REPAIR CONNECTION

SUBSTITUTE SPEAKER (USE  
FADER IF SO EQUIPPED.)

STOP

REMOVE RADIO.

NO RECEPTION

RADIO WORKS

REMOVE  
RADIO

REPLACE MALFUNCTIONING  
SPEAKER/WIRING ASSEMBLY.

Fig. 9-9R--Radio Diagnosis, Chart E

# SLIMLINE POWER ANTENNA DIAGNOSIS

ANTENNA WILL NOT TRAVEL TO FULL UP OR DOWN POSITIONS OR DOESN'T MOVE (MOTOR RUNS) (BE SURE MAST IS CLEAN)

Pull up on top section of mast. If section moves freely, plastic drive cable is broken.

NOT BROKEN

BROKEN DRIVE CABLE

Remove mast and support tube. Check mast sections for free movement.

Replace mast and support tube.

FREE

BINDING

Check drive cable for broken hook. If OK replace gear and spool assembly.

Free up sections or replace mast and support tube.

ANTENNA WILL NOT LOWER (MOTOR DOES NOT RUN) CHECK FUSE CIG-CLK-DM

FUSE OK

FUSE BLOWN

Probe orange wire terminal at antenna relay with 12V. test light

Disconnect connector with orange wire at relay. Install new fuse and recheck.

LIGHT ON

NO LIGHT

FUSE BLOWN

FUSE OK

Use a 12 volt test light and probe white wire at antenna relay connector.

Locate and repair open circuit in orange wire from relay to fuse panel.

Repair short in orange wire.

Disconnect other connector. Connect orange wire connector, recheck fuse.

LIGHT OFF

LIGHT ON

FUSE BLOWN

FUSE OK

Replace Relay

Check white wire from relay to antenna for open circuit. If OK probe dk. green wire.

Replace relay.

Check and repair white wire to antenna. If OK repair antenna motor assembly.

LIGHT ON

NO LIGHT

Check relay connections: ground wire (black) and ground screw. If OK, replace relay.

Check dk. green wire relay to connector and connector to antenna for loose connection or open circuit. If OK repair motor assembly.

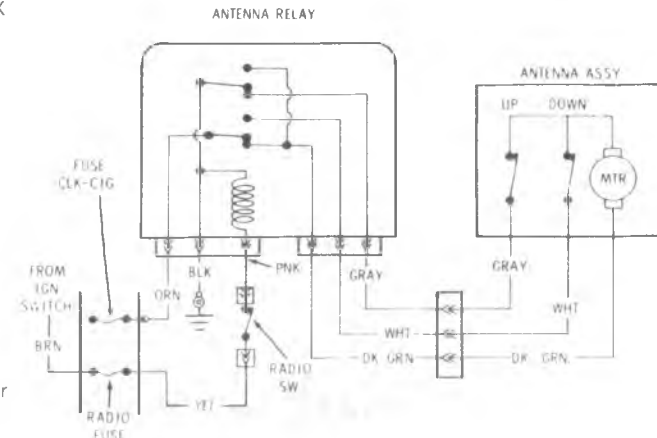

Fig. 9-10R--Slimline Power Antenna Diagnosis, Chart F

# SLIMLINE POWER ANTENNA DIAGNOSIS (CONT'D)

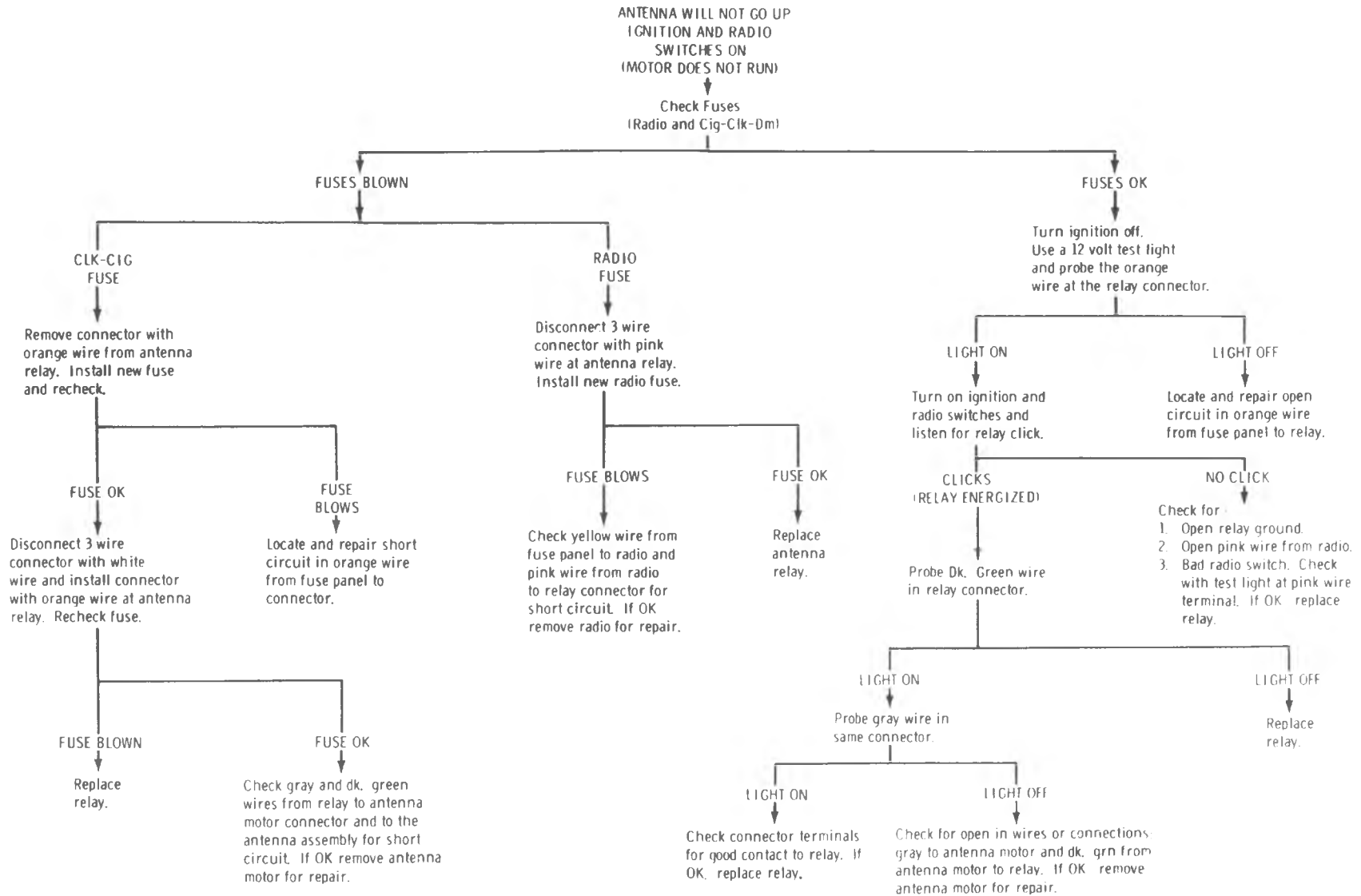

Fig. 9-11R--Slimline Power Antenna Diagnosis, Chart G

## POWER ANTENNA

## General Description and Operation

The power antenna automatically raises the antenna mast to its full height whenever the radio and ignition are turned on. The antenna retracts into the fender when either the ignition or radio is turned off.

The power antenna drive unit is housed in a 2 piece plastic housing attached to the mast and tube assembly. A permanent magnet motor with worm drive moves the antenna mast up and down with a plastic cable attached to the top mast section. No clutch is used in this unit. Upper and lower travel limits are controlled by switches opened by armature shaft thrust as the mast reaches the end of its travel. A circuit breaker is used to protect the motor armature from over heating.

Two types of power antennas are used depending on the type of radio used in the car:

- 1) AM-FM Type
- 2) AM-FM-CB (Tri-Band) Type

The AM-FM antenna extends to a maximum height of 794 mm (31 1/4"). The AM-FM-CB (Tri-Band) antenna extends to a height of 914 mm (36"). The tri-band antenna has a load coil mounted on the center mast section to tune it to the CB radio band and a stub antenna lead taped to the support tube. The stub matches the antenna to the FM band and should not be removed except for replacement.

## On Car Service

There is no on car service of the AM-FM antenna other

than cleaning of the mast sections. On the Tri-Band antenna the load coil and tip are serviceable in the event of damage or loss. The load coil has an adjustable band to set SWR (Standing Wave Ratio) for CB operation. The SWR is preset on complete antenna assemblies but replacement load coils must be checked and/or adjusted using available SWR meters.

## Checking SWR

**NOTICE:** SWR checking procedures require transmitter operation and FCC regulations governing CB radio operation apply. The following options are available.

- Have SWR test performed by a technician who has a CB license.
- Acquire a dealership CB radio operator's license which allows technicians to use license during business hours.
- Ask owner or an operator possessing a permanent CB Radio license to properly operate transmitter during the test.

Adjustments or repairs referred to in the procedure that follows are limited to the antenna itself or the antenna lead in and connections.

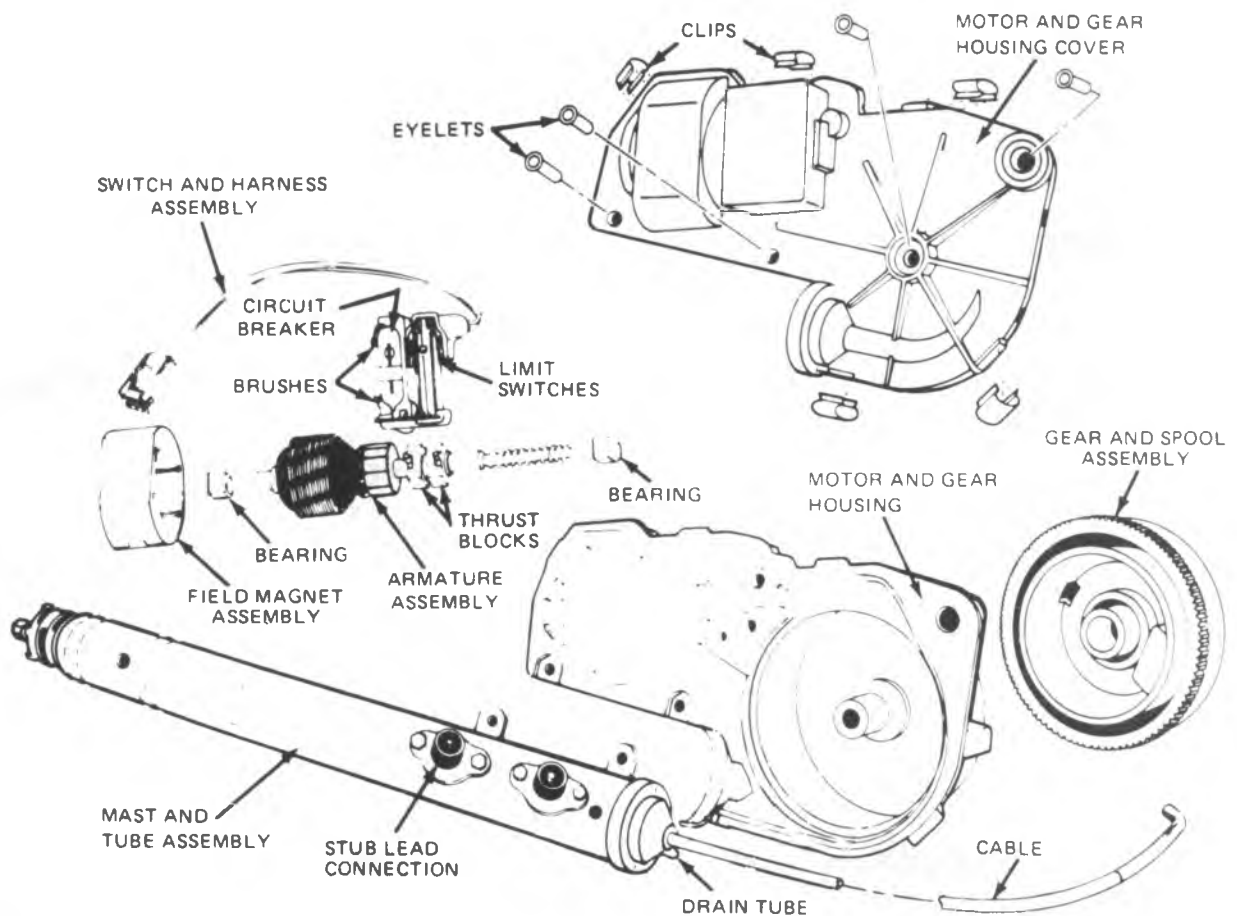
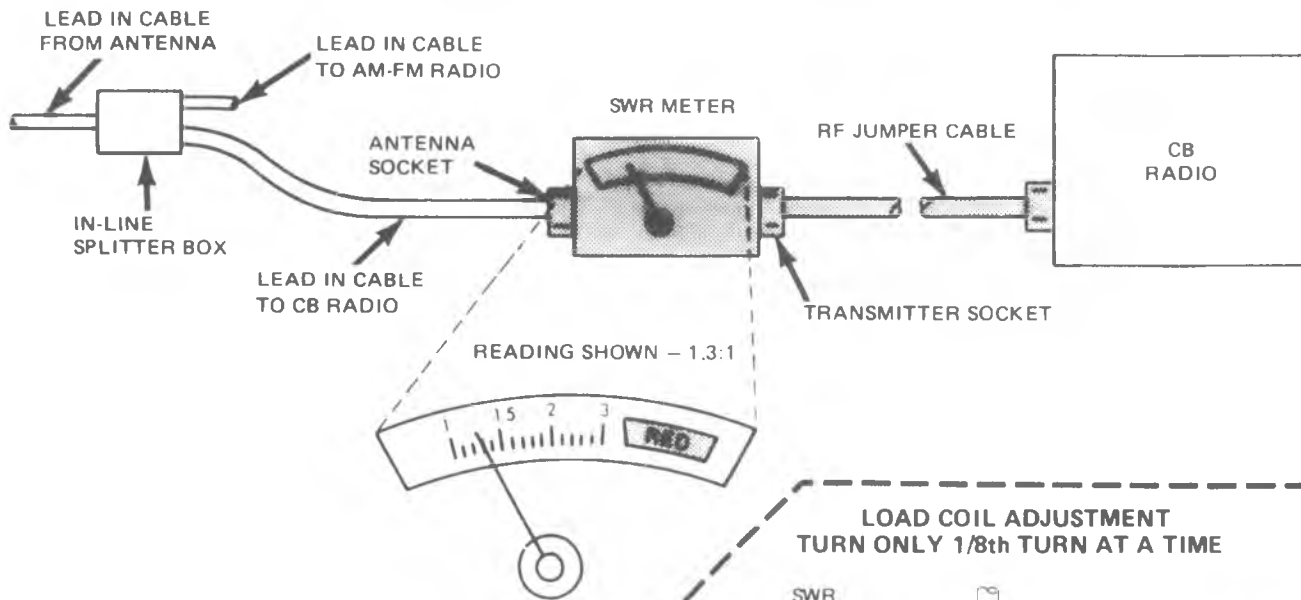

Fig. 9-12R--Slimline Power Antenna Diagnosis, Chart H

**SWR (STANDING WAVE RATIO) CHECK**

1. With Ignition and Radio off install an SWR meter as shown following meter manufacturers instructions.
2. Turn on Ignition and Radio.
3. Check Antenna height – Must be fully extended.  
914 mm (36") from fender to tip  
286 mm (11-1/4") top of load coil to tip.
4. After adjustment is complete apply a small amount of thread cement to adjusting band.

**NOTICE:** Operation of transmitter requires FCC CB Operators License.  
When making this check, car should be at least 20 feet away from any building, hood closed and no one should be standing close to the antenna.



**POSSIBLE SWR READINGS**

1. Initial readings taken on Channel 1, 20, 40
  - a. SWR of 2:1 or lower on Channel 20 and nearly equal on Channels 1 and 40 is considered good. No adjustment required.
  - b. SWR higher than 2:1 on Channel 20. Adjustment required.
  - c. Unequal SWR on Channels 1 and 40 (one channel in red) indicates adjustment required.

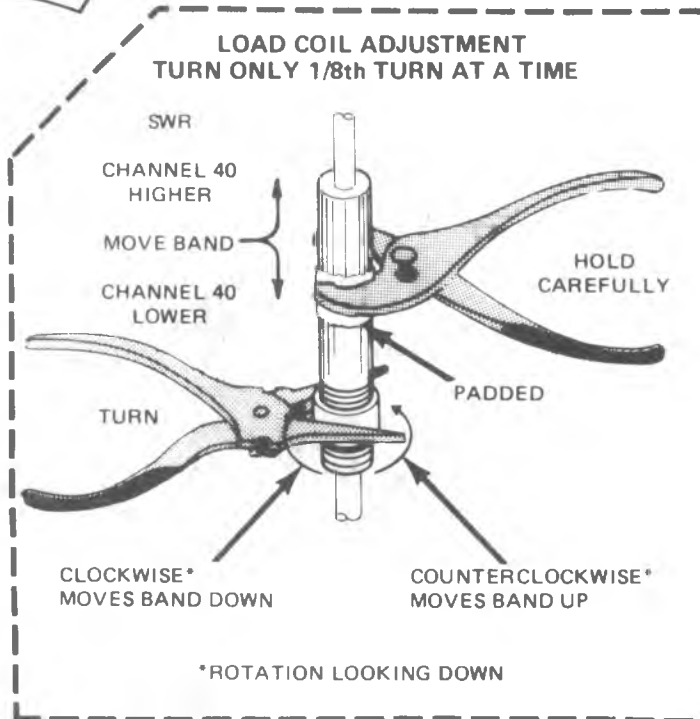

**ANY READING IN THE RED BAND (ABOVE 3:1 SWR) CHECK FOR:**

- Antenna mounting screws tight making a good ground connection between antenna mounting surface and car sheet metal.
- Lead in cable connections to radio, splitter and antenna are tight.
- Lead in cables not pinched and cutting the insulation.

Fig. 9-13R-Slimline SWR Check

## ON VEHICLE SERVICE

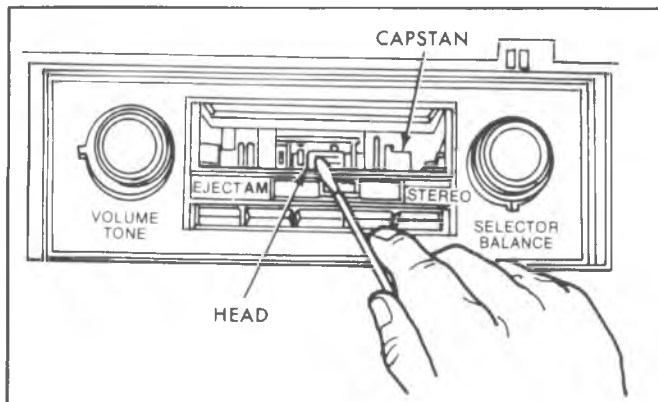

Fig. 9-14R--Cleaning Tape Player Head -Typical

## MAINTENANCE AND ADJUSTMENTS

### TAPE PLAYER MAINTENANCE

The only required maintenance on tape players is periodic cleaning of the tape player head and capstan. This service should be performed every 100 hours of operation. Since you can reach them through the tape door, you can leave the tape player in the truck.

To clean the head and capstan, use a cotton swab dipped in ordinary rubbing alcohol. Wipe the head and capstan as shown in Figure 9-14R.

No lubricants should be used since they will cause the player to operate improperly, especially at extreme temperatures.

Do not bring any magnetized tools near the tape head. If the head becomes magnetized, every cartridge played in the player will be degraded.

To operate the tape player, completely insert a cartridge into the unit. This turns the tape player on, automatically removes power from the radio, and switches the speakers from the radio to the tape player. This feature prevents accidental damage to the radio should the owner attempt to operate it while the tape player is in use.

After the tape player is in operation, the front panel controls of the player are then adjusted for the most pleasant stereo listening.

The tape player is equipped with a cartridge locking

arm to hold the cartridge in a rigid position against the capstan drive for minimum wow and flutter. As the cartridge is withdrawn from the player, the on/off switch at the other side of the cartridge is not completely disengaged when the cartridge lock arm reaches a detent point on the cartridge. Always withdraw the cartridge just beyond the detent point for normal operation from the radio.

Tape cartridges should be handled carefully and should be kept clean and out of direct sunlight. A cartridge should not be left inserted fully in the player. This may cause permanent damage to the cartridge.

### ANTENNA TRIMMER ADJUSTMENT-ALL RADIOS (Fig. 9-15R)

The antenna trimmer adjustment must be made any time the radio is removed and installed, a new windshield or lead-in is installed or if weak, AM reception is noted. (Fig. 9-15R).



Fig. 9-16R--Antenna Lead (C-K Models)

1. TURN RADIO ON AND TUNE RADIO FOR WEAK STATION AT OR NEAR 1400 KC.
2. REMOVE RIGHT HAND KNOBS.
3. TURN VOLUME UP.
4. CAREFULLY TURN ANTENNA TRIMMING SCREW BACK AND FORTH UNTIL MAXIMUM VOLUME IS OBTAINED SET TRIMMER AT PEAK VOLUME.

NOTE ON CARS WITH POWER ANTENNA, TRIM WITH MAST FULLY EXTENDED.

ANTENNA TRIMMER

Fig. 9-15R--Trimming Radio



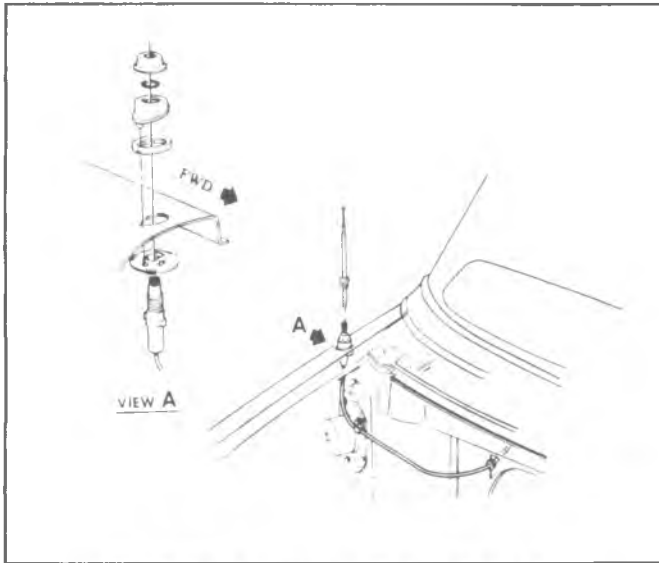

Fig. 9-17R--Antenna Installation (G Models)

## COMPONENT PART REPLACEMENT

### RADIO OR RADIO TAPE REMOVAL

(Refer to Section 8).

### RADIO DIAL LAMP REMOVAL

(Refer to Section 8).

### RADIO SPEAKER REMOVAL

(Refer to Section 8).

## ANTENNA

### C-K Models

#### Antenna Replacement

Refer to Section 2 of this manual "Windshield Replacement" procedure.

#### Cable Replacement (Fig. 9-16R)

1. Disconnect battery ground cable.
2. Unsnap antenna cable from windshield.
3. Remove bracket to dash panel screws.
4. Disconnect cable at rear of radio receiver and remove cable assembly.

### G Models

#### Antenna Replacement (Fig. 9-17R)

1. Unscrew mast nut. Prevent the cable assembly from turning by using two separate wrenches. Remove rod and mast assembly.
2. To install, insert rod and mast assembly into cable assembly and tighten mast nut. Prevent cable assembly from turning by using a second wrench.

#### Cable Assembly Replacement (Fig. 9-17R)

1. Disconnect battery ground cable.
2. Remove antenna assembly as described above.
3. Remove cable body nut and then remove seal, bezel, gasket and ring ground.

4. Perform Steps 2-8 of "Radio Receiver Removal". Refer to Section 8.
5. Disconnect cable at rear of receiver.
6. Insert new cable through the dash panel (from the forward side).
7. Reverse Steps 1-5 above to complete installation.  
Be sure cable grommet is properly positioned in dash panel.

## POWER ANTENNA

### DESCRIPTION AND OPERATION

The power antenna used on "G" models operates automatically whenever the radio is turned on. The drive gear unit on the automatic system consists of a drive gear and pulley assembly and a spool for storing the excess nylon drive cable when the mast is in the retracted position, plus two limit switches and a gear operated cam system to actuate the switches. The limit switches are used to open the motor circuits when the mast reaches the full up or down positions.

When the motor circuit is completed by the radio or ignition switch, the motor drives the gear and pulley to extend the drive cable and antenna.

The gear is coupled to the drive pulley by a torque limiting clutch that permits continued gear rotation when the mast reaches the limit of travel. The antenna mast fully retracts into the fender or extends 31-1/4" and has no intermediate position.

### POWER ANTENNA - G MODELS

#### Replacement (Fig. 9-18R and 9-19R)

1. Lower antenna by turning off radio or ignition.
2. Disconnect battery ground cable.
3. Remove coolant recovery bottle.
4. Remove motor lower bracket retaining nut and upper bracket screws.

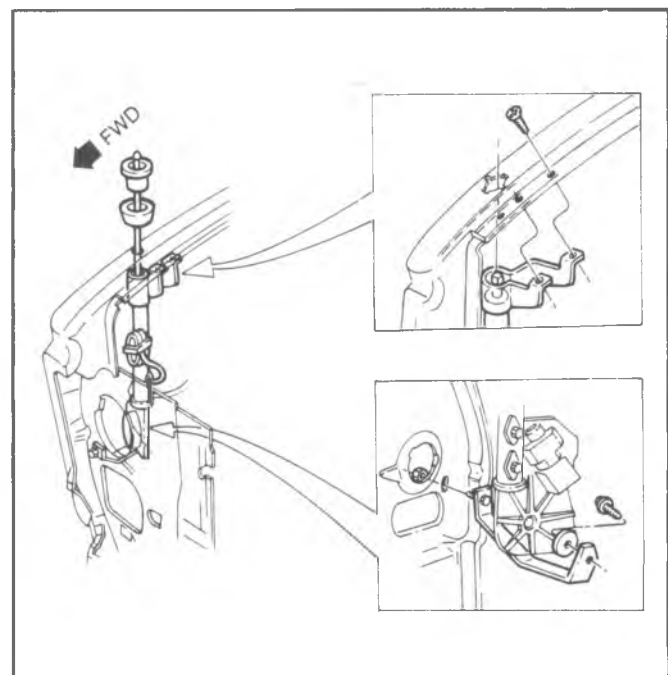

Fig. 9-18R--G Model Power Antenna

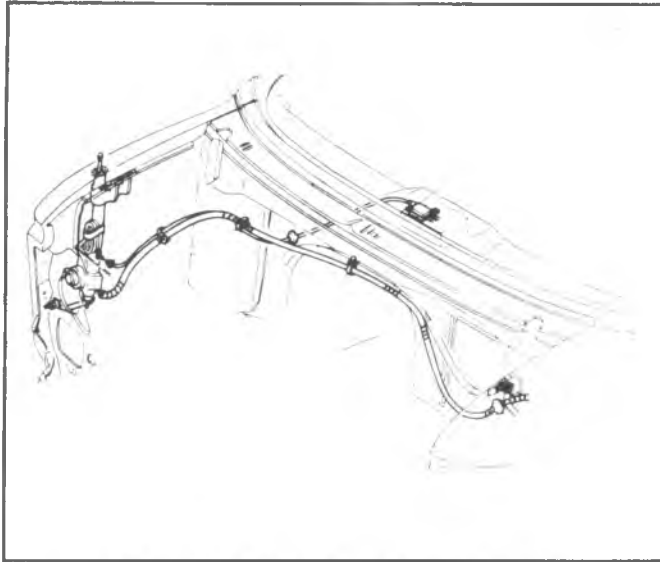

Fig. 9-19R--G Model Power Antenna Wiring

5. Disconnect electrical leads and remove antenna and motor assembly.
6. To install, reverse steps 1-5 above.

#### **POWER ANTENNA RELAY**

The power antenna relay is bracket mounted to the parking brake assembly as illustrated in figure 9-20R.

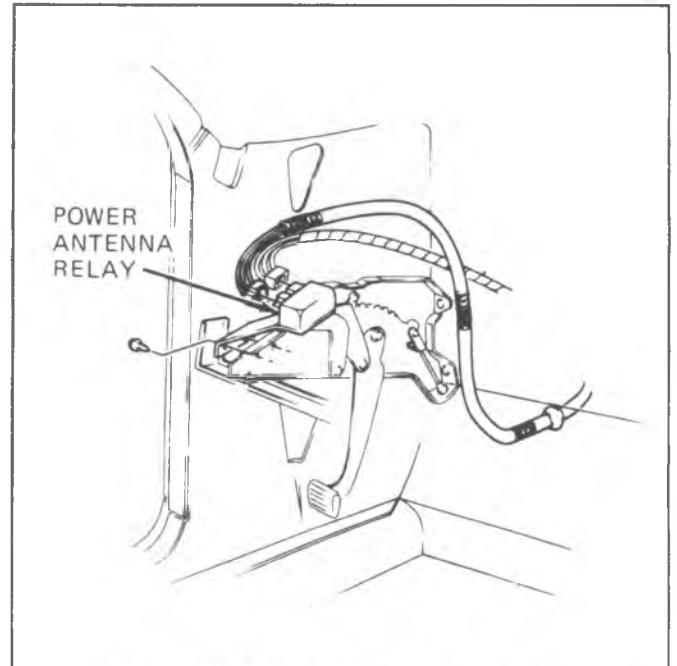

Fig. 9-20R--G Model Power Antenna Relay

### POWER ANTENNA DISASSEMBLY-SLIMLINE

**NOTICE:** With the exception of load coil on the tri-band antenna, all service operations require opening the motor and gear housing. All disassembly will require a bolt and clip package.

#### 1. REMOVE AND INSTALL MOTOR AND GEAR HOUSING COVER.

##### REMOVAL

1. Remove parts shown.
2. Separate housing and cover as shown.

##### EYELETS

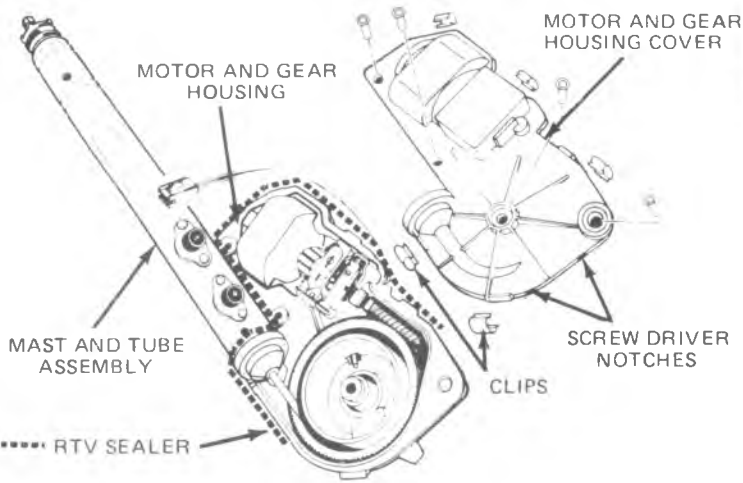

##### INSTALL

1. Remove loose or excess sealer and reassemble using 3 bolts and nuts, from service package and the 5 clips.
2. Apply RTV sealer around support tube and along seam on top half of housing.

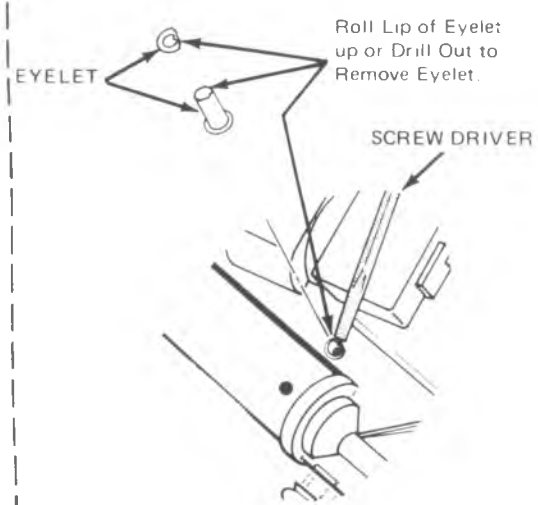

#### 2. REMOVE AND INSTALL MAST AND TUBE ASSEMBLY.

##### REMOVAL

1. Remove parts as shown:

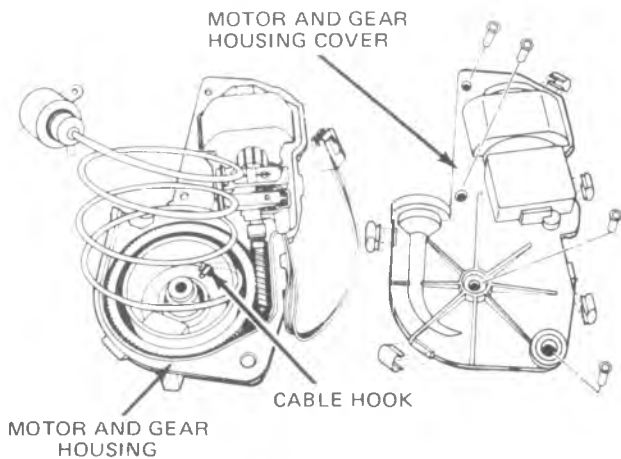

Disengage cable from gear by rotating cable 90°

##### INSTALL

1. Reassemble as shown with mast extended to reduce length of cable.
2. Run motor to lower mast into support tube. Reseal housing and support tube.

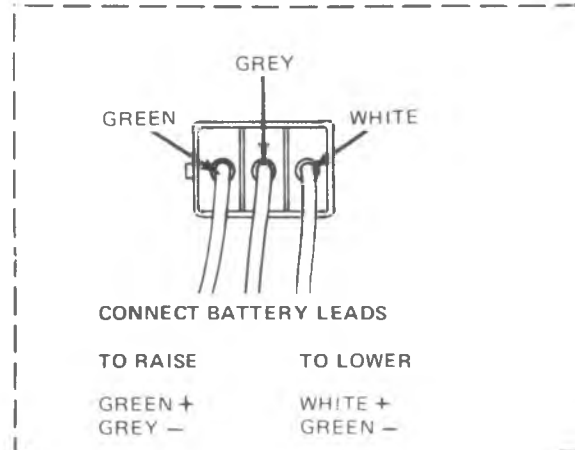

Fig. 9-21R--Slimline Disassembly I

**3. REMOVE AND INSTALL SWITCH AND HARNESS ASSEMBLY.**

**REMOVAL**

1. Remove parts as shown.
2. Remove excess sealer where wire goes through housing.

**INSTALL**

1. Position switch.
2. Reseal area where wires come out of housing. Reseal housing.

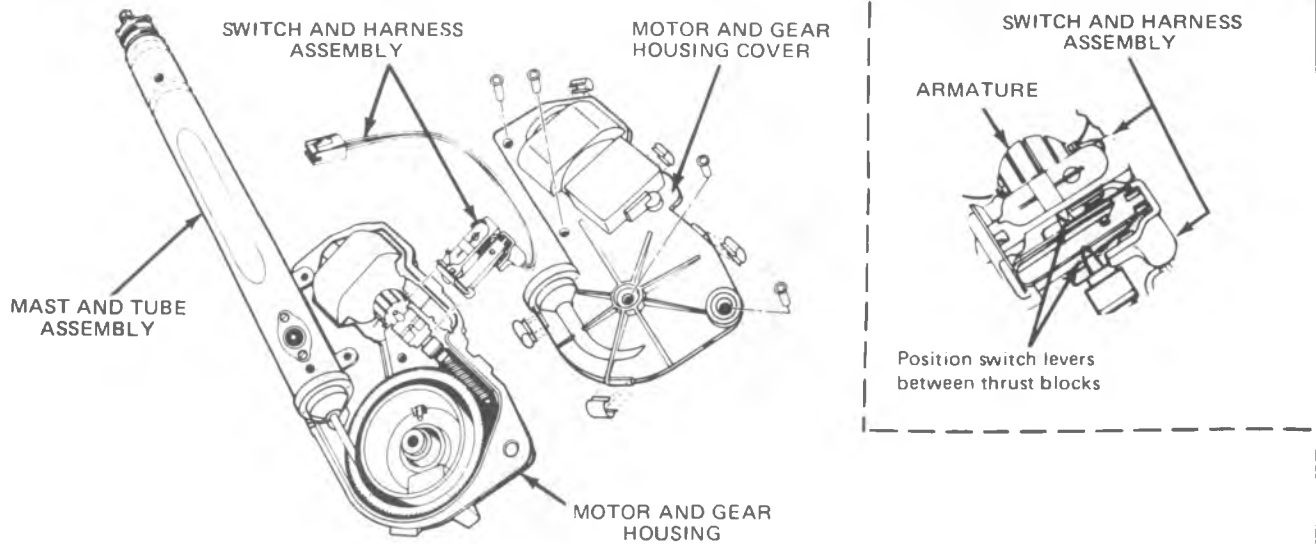

**4. REMOVE AND INSTALL ARMATURE AND MAGNET ASSEMBLY.**

**REMOVAL**

1. Remove parts as shown.
2. Cleanout old grease.

**INSTALL**

1. Lubricate worm and gear with lithium soap grease such as Sun Oil Prestige #2 or equivalent.
2. Apply drop of light oil to bearings.
3. Reassemble and seal housing.

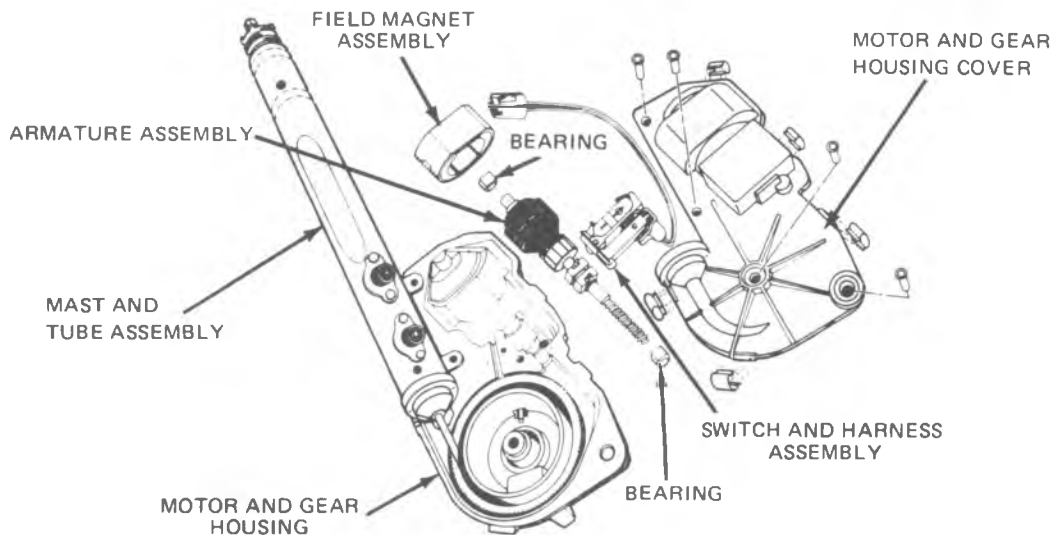

Fig. 9-22R--Slimline Disassembly II

**5. REMOVE AND INSTALL GEAR ASSEMBLY.**

**REMOVAL**

1. Disassemble as shown.
2. Clean out old lubricant.

**INSTALL**

1. Apply lubricant to worm and gear.
2. Reassemble and seal housing.

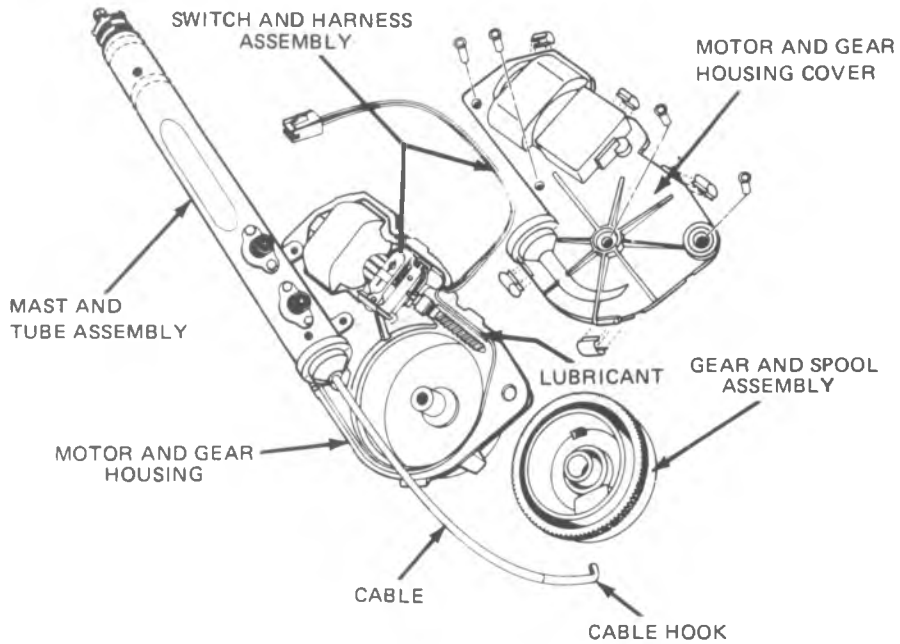

**6. REMOVE AND INSTALL CB LOAD COIL AND/OR TIP.**

**REMOVAL**

1. Disconnect Neg. Battery Cable.
2. Turn on ignition and radio then connect battery long enough to raise antenna about half way.
3. Remove parts as shown using padded pliers.

**INSTALL**

1. Reassemble as shown using thread cement to lock in place.
2. Adjust S.W.R. (See SWR adjustment procedure)

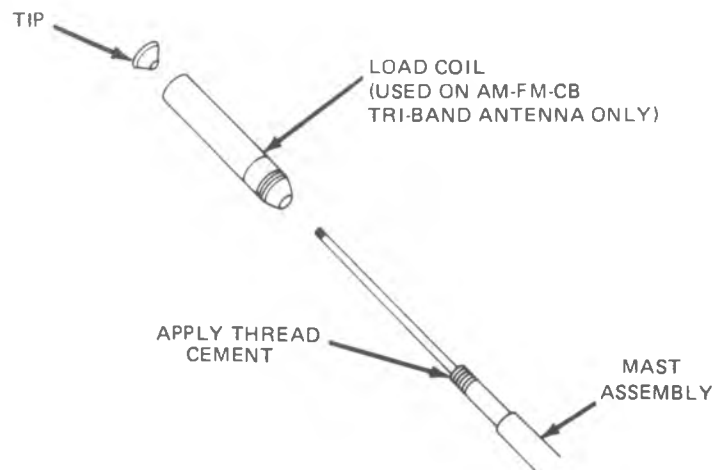
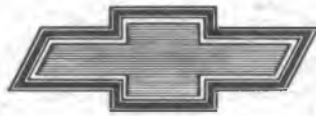

Fig. 9-23R--Slimline Disassembly III



**CHEVROLET**

**SERVICE**