

1988 LIGHT DUTY TRUCK WIRING DIAGRAM BOOKLET

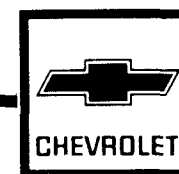

ST-350-88



WIRING DIAGRAMS

All diagrams in this manual are based on the latest product information at the time of publication approval. The right is reserved to make changes at any time without notice.

<u>SUBJECT</u>	<u>PAGE</u>
Description	2
Tracing Circuits	2
Basic Electric Circuits	2
Circuit Diagnosis	6
Abbreviation List	7
Diagnostic Tools	9
Wire Size Conversion Table	11
On-Vehicle Service	11
Circuit Maintenance and Repair	11
Weather Pack Connectors	12
Metri-Pack Connectors	12
Wiring Repair	14
Special Tools	15

<u>VEHICLE</u>	<u>SECTION</u>
C/K Models	A-1
G Van	B-1
S/T Models	C-1
R/V Models	D-1
P Chassis	E-1
M Van	F-1

DESCRIPTION

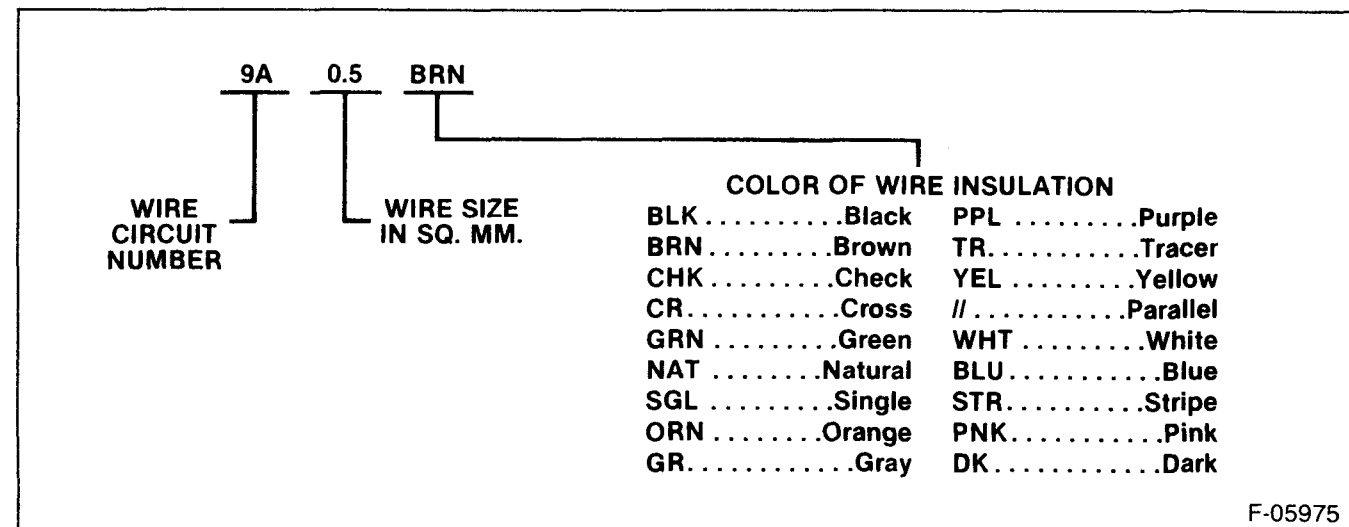

Figure 1—Wire Coding

- The diagrams are to be traced from the source of electricity (the battery positive post) to ground. The ground may be a chassis ground on a certain component (such as an alternator or a starter), or a wire from a component to a chassis or frame ground (such as used on the electronic control module and instrument panel). All grounds are connected to the negative battery post through body and/or engine ground wires and straps.
- Many times the source of the electricity is shown as the ignition switch or the fuse block. This is done to eliminate the confusion that would occur if the entire power distribution was shown in each circuit. For a detailed outline of the power to the ignition switch or the fuse block, refer to the power distribution circuit.
- The ground portion of the circuit (usually circuit 150 or 151) may be shown entirely, or it may refer to the ground distribution circuit in order to avoid confusion of listing all the grounds in one splice on a single page.
- For ease of diagnosis, all splices and grounds are identified by number, and all the wires in a common splice or ground are identified by circuit number, size (in mm) and color. Each component or circuit common to a spliced wire is called out by the page number of that circuit. This will help identify and diagnose multiple electrical problems that could occur in a truck.
- All connectors are shown with their part numbers to save time when ordering these parts.
- Switches are shown in their at rest positions, unless otherwise marked.

TRACING CIRCUITS

Figures 1 through 3 are examples of how the wiring diagrams are laid out, and will be referred to, throughout this description.

In order to trace a circuit on these diagrams, start from the source, the battery. In figure 2, the battery positive

circuit is a 19.0 mm black wire. This wire runs from the battery to the starter motor, and supplies power to the starter motor post.

Once you have determined the source of power to your component, from the Power Distribution Circuit (figure 2), then refer to the individual circuit you are working on for more detail about that circuit. (Figure 3 shows the starting circuit).

In figure 3, the starter motor circuit is shown. This circuit shows the battery feed coming from the Power Distribution page. The cable comes from the battery to the starter positive post. At the starter post, other circuits such as the generator, ignition switch, and electronic control module are fed.

When the ignition switch is in the start position, power flows from circuit #2 through the switch, to circuit #6. Circuit #6 goes through the clutch switch with an automatic transmission. At the clutch switch the circuit is opened, unless the clutch is depressed.

At the solenoid the current flowing from circuit #6, closes the solenoid, allowing current to flow from the battery at circuit #1 to the starter motor. The current flowing to the starter motor, causes the starter motor to spin.

BASIC ELECTRICAL CIRCUITS

An electrical circuit starts from a supply of electricity back to a load and then conducts the electricity back to the supply of electricity. There should be a device to open and close the circuit, and a protective device to open the circuit in case too much current is drawn into the circuit by an overload condition. Electrical circuits can be set up as series circuits, parallel circuits or series/parallel circuits. The circuits in trucks are usually parallel circuits.

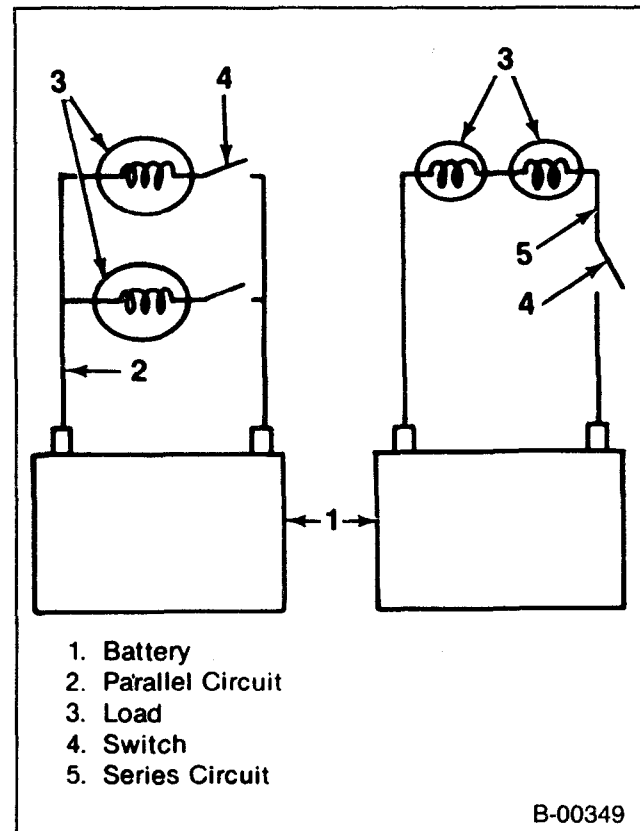

Figure 4—Basic Circuits

SERIES CIRCUITS (Figure 4 and 5)

In a series circuit, the electrical devices are connected together to form one current path to and from the power supply. In a series circuit the same current flows through all of the devices.

PARALLEL CIRCUITS (Figure 5)

In a parallel circuit, the electrical devices are connected to form more than one current path to and from the power supply. In a parallel circuit the supply voltage is the same in each current path.

SERIES/PARALLEL CIRCUIT (Figure 5)

A series/parallel circuit consists of a single current path circuit and a circuit with more than one current path to and from the voltage supply.

CIRCUIT COMPONENTS (Figure 6)

The usual circuit path starts at the power supply which is the battery/generator system. Next in the circuits is the circuit protection component which can be a fusible link, a fuse, or a circuit breaker. Then the circuit goes to the circuit controller which can be a switch or a relay. From the circuit controller the circuit goes into the circuit load. The circuit load can be one light or many lights in parallel, an electric motor or a solenoid. After the electricity has passed through the load it must return to the power supply via the ground path. The ground path can be a wire in the harness or it could be through the load housing into the body or frame, thus returning the electricity to the power supply. The body and frame are connected by flexible ground straps.

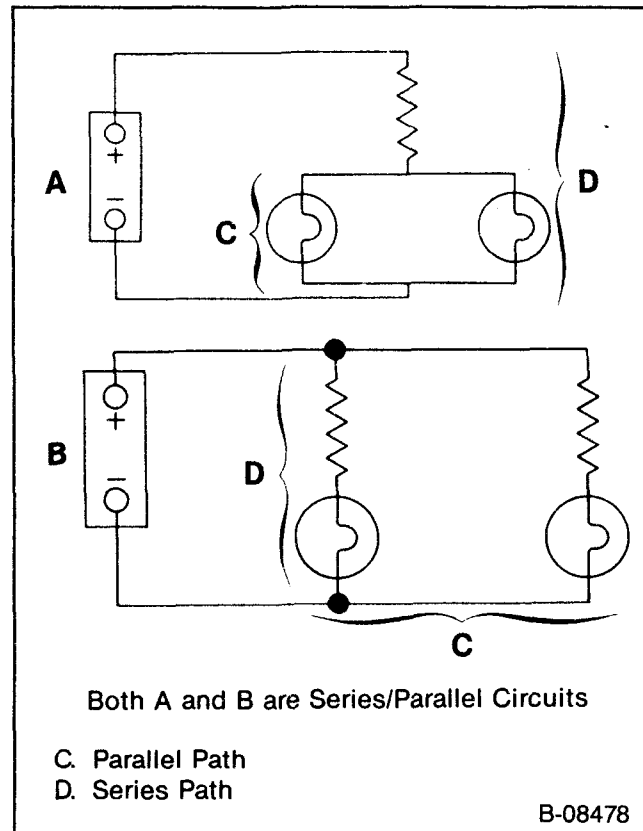

Figure 5—Series/Parallel Circuits

FUSIBLE LINK

A fusible link is a section of wire that is usually four gage sizes smaller than the circuit it protects. A special insulation is used that swells when heated by the wire. Fusible links are usually found in the engine compartment harnesses. The function of the fusible link is to melt open when an overload occurs, thus preventing any damage to the circuit.

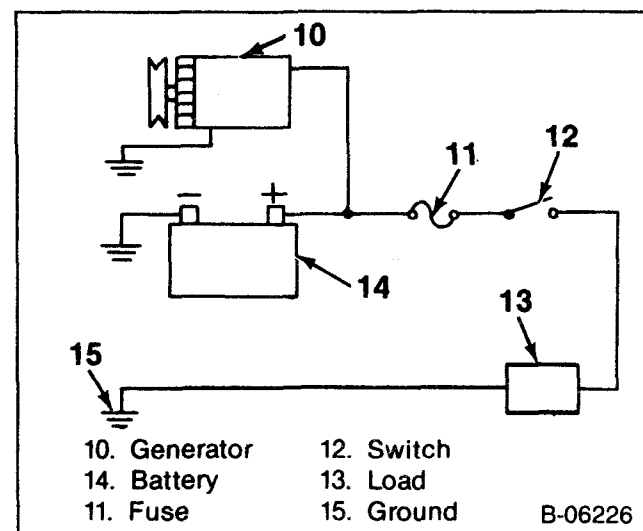

Figure 6—Circuit Components

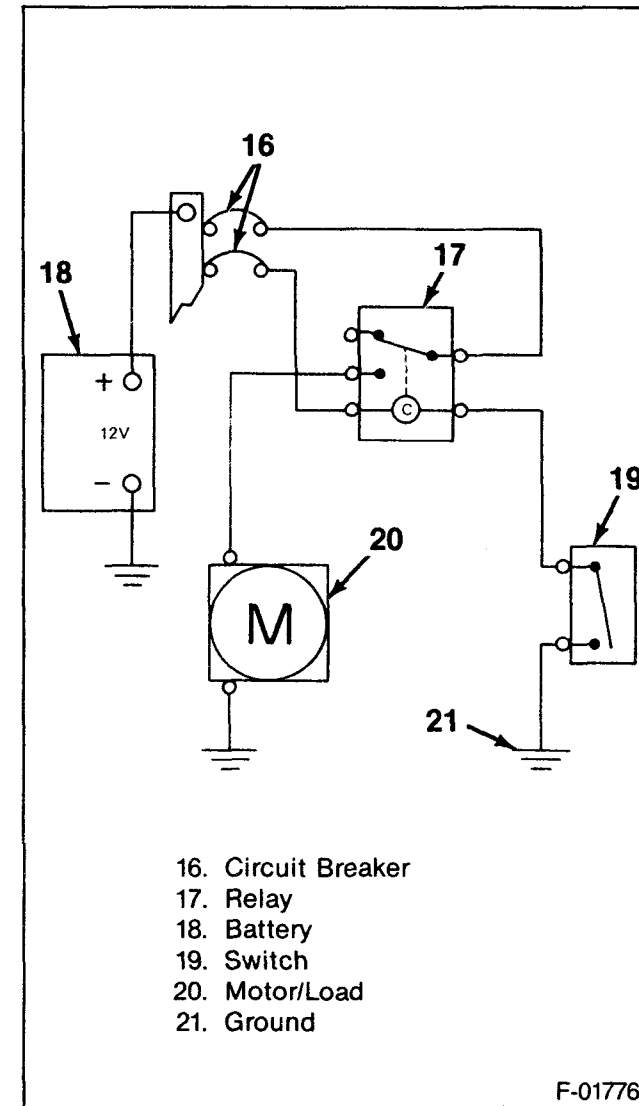

Figure 7—Circuit Controllers

FUSES (Figure 6)

The most common protector in the vehicle circuit is a fuse. A fuse consists of a fine wire or strip of metal inside a glass tube or plastic housing. The strip melts and interrupts the flow of current in the circuit when there is an overload caused by an unwanted short or ground. The fuse is designed to melt before the wiring or electrical components in a circuit can be damaged. Naturally, the cause must be located and corrected before the fuse is replaced or the new fuse will also blow.

Since different circuits handle different amounts of current, fuses of various ratings are used. Fuses are rated in amperes. Be sure to replace a blown fuse with a fuse of the connecting rating.

CIRCUIT CONTROLLERS (Figure 7)

Circuit controllers consist of switches or relays. Switches are usually operated by a mechanical means such as a hand or lever. Switches are usually at the beginning of a circuit but can be used to control a ground

path. For example the switch controlling the headlights is at the power end of the circuit while the door switch controlling the domelight completes the ground path.

Relays are remotely controlled switches. They are used in high current circuits and in circuits controlled by sensors.

Relays are designed so that a small current circuit will be able to control a large current circuit.

CIRCUIT BREAKERS (Figure 7)

Circuit breakers are another form of circuit protector. There are two types of circuit breakers; automatic reset and remote reset.

The automatic reset breaker opens when excess current heats a bimetallic strip, causing the strip to bend and open a set of contacts. Then the strip cools and closes the contacts. So the circuit breaker opens and closes until the excess current condition is corrected or the circuit is disconnected from the power supply.

The remote reset circuit breaker has a heating wire wound around the bimetallic strip. When an excess current happens, the strip heats, bends, and opens the contacts. Then a small current flows through the heating wire, keeping the strip hot and the contacts open. This type of breaker will stay open until either the power supply is disconnected from the circuit or the breaker is removed from the circuit. Then the breaker can cool and reset.

CIRCUIT LOADS (Figure 7)

Circuit loads are the components that use most of the energy in circuit. The energy converts to motion, light, or heat. Lights, motors, and engine heaters are the most common loads in circuits.

CIRCUIT DIAGNOSIS

A clear understanding of the circuit and a wiring diagram are needed for effective diagnosis. Use a logical sequence of testing to find the trouble. Use the diagnostic tools. After the trouble is fixed, make sure the circuit works correctly.

CIRCUIT MALFUNCTIONS

There are three electrical conditions that can cause a nonworking circuit; an "Open Circuit", a "Short Circuit", or a "Grounded Circuit."

OPEN CIRCUIT (Figure 8)

An open circuit occurs whenever there is a break in the circuit. The break can be corrosion at the connector, a wire broken off in a device, or a wire that burned open from too much current.

SHORT CIRCUIT (Figure 9)

A short circuit happens when the current bypasses part of the normal circuit. This bypassing is usually caused by wires touching, salt water in or on a device such as a switch or a connector or solder melting and bridging conductors in a device.

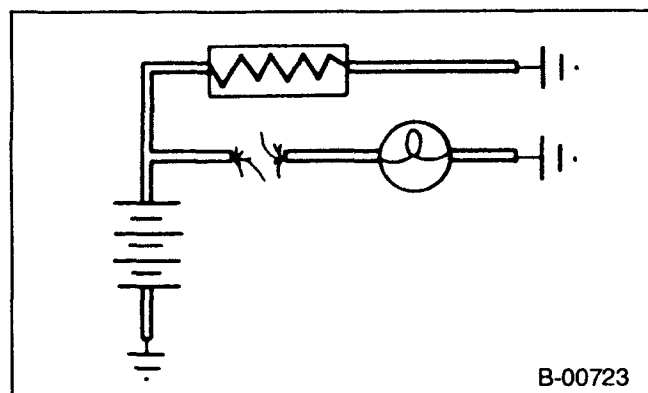

Figure 8—Open Circuit

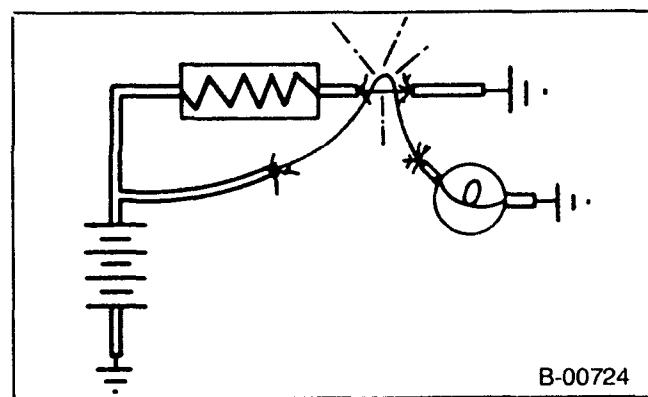

Figure 9—Short Circuit

GROUNDING CIRCUIT (Figure 10)

A ground circuit is like a short circuit but the current flows directly into a ground circuit that is not part of the original circuit. This may be caused by a wire rubbing against the frame or body. Sometimes a wire will break and fall against metal that is connected electrically to the ground side of the power supply. A grounded circuit may also be caused by deposits of oil, dirt and moisture around connections or terminals, which provide a good path to ground.

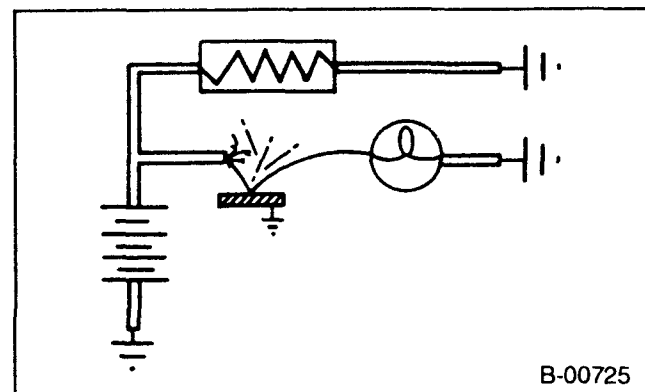

Figure 10—Grounded Circuit

ABBREVIATION LIST

The following is a list of abbreviations used in the wiring diagrams. The abbreviations have been developed in such a way that their meaning should be clear.

Use this page as a reference to determine the meaning of an abbreviation if necessary.

- A—Ampere
- A/C—Air Conditioner
- ACC—Accessory
- A.I.R.—Air Injection Reaction
- AIR/COND—Air Conditioner
- ALDL—Assembly Line Diagnostic Link
- ALT—Alternator
- AMP—Ampere
- ANTI—Anticipate
- ASM—Assembly
- ASS'Y—Assembly
- AUD—Audio
- AUTO—Automatic
- AUX—Auxiliary

- BAT—Battery
- BATT—Battery
- BI-LEV—Bi-Level
- BLK—Black
- BLT—Belt
- BLU—Blue
- BOT—Bottom

- BRK—Brake
- BRN—Brown
- BU—Backup
- BUZZ—Buzzer

- CIR/BRK—Circuit Breaker
- CIRC—Circuit
- CLSTR—Cluster
- CNTL—Control
- COMP—Compartment
- COMP—Compressor
- CONN—Connector
- CONV—Convenience
- CTSY—Courtesy
- CYL—Cylinder

- DK—Dark
- DIAG—Diagnostic
- DIM—Dimmer
- DIR—Directional
- DISC—Discrete
- DIST—Distributor
- DIV—Diverter
- DM—Dome
- DR—Door

- ECM—Electronic Control Module

- EFE—Early Fuel Evaporation
- EGR—Exhaust Gas Recirculation
- ELEC—Electric
- ELEC—Electronic
- CNTRL—Control
- MOD—Module
- ENG—Engine
- EPR—Exhaust Pressure Regulator
- ESC—Electronic Spark Control
- EST—Electronic Spark Timing
- EVRV—Electronic Vacuum Regulator Valve
- EXC—Except

- F-PUMP—Fuel Pump
- FLASH—Flasher
- FRT—Front
- 4WD—Four Wheel Drive

- GEN—Generator
- GRA—Gray
- GRD—Ground
- GRN—Green

- HAND—Handling
- HAZ—Hazard
- HD—Heavy Duty
- HD LP—Headlamp
- HEI—High Energy Ignition
- HI—High
- HTR—Heater

- IAC—Idler Air Control
- IGN—Ignition
- ILLUM—Illumination
- I/P—Instrument Panel
- INC—Increased
- IND—Indicator
- INJ—Injector
- INST PNL—Instrument Panel
- INTER—Interior

- LD—Light Duty
- LH—Left Hand
- LO—Low
- LP—Lamp
- LPS—Lamps
- LT—Light
- LTR—Lighter

- M—Motor
- MAN—Manual
- MAP—Manifold Absolute Pressure
- MAX—Maximum
- MED—Medium
- MRKR—Marker
- MULT—Multiple

- NAT—Natural
- NEUT—Neutral
- NO—Normally Open
- NC—Normally Closed

- ORN—Orange

- PK—Park
- PLR—Puller
- PNK—Pink
- PNL—Panel
- PPL—Purple
- PRESS—Pressure
- PWR—Power

- RCVR—Receiver
- REF—Reference
- RESIST—Resistance
- RH—Right Hand
- RPO—Regular Production Option

- SEN—Sensor
- SEND—Sender
- SIG—Signal
- SIL—Silver
- SKT—Socket
- SOL—Solenoid
- SPEEDO—Speedometer
- STR—Stripe
- SW—Switch

- TACH—Tachometer
- TBI—Throttle Body Injection
- TCC—Torque Converter Clutch
- TEMP—Temperature
- T/L—Tail Lamp
- TRANS—Transmission
- TYP—Typical

- V—Volt
- VAC—Vacuum
- VLV—Valve
- VSS—Vehicle Speed Sensor

- W/—With
- W/O—Without
- W/S—Windshield
- W WASHER—Window Washer
- WDO—Window
- WHT—White
- WRG—Wiring

- YEL—Yellow

DIAGNOSTIC TOOLS

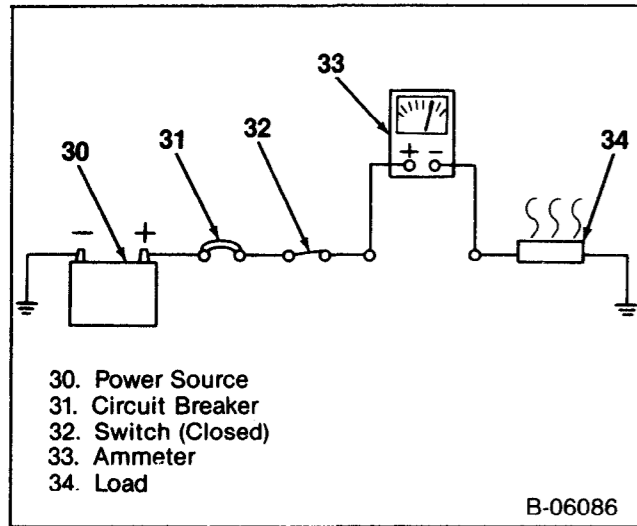

Figure 12—Ammeter

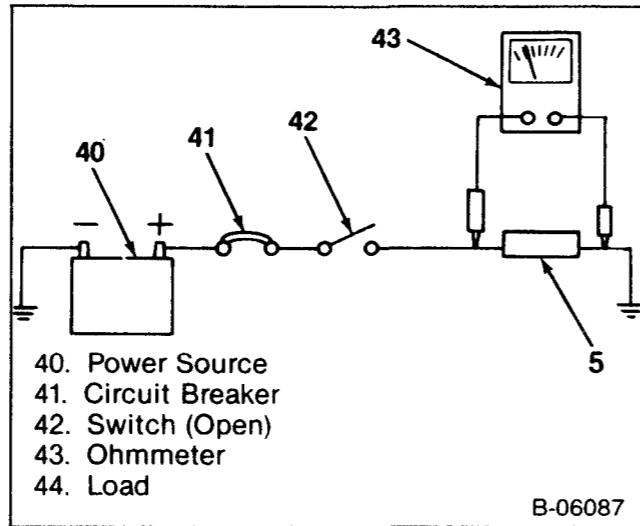

Figure 13—Ohmmeter

UNPOWERED TEST LIGHT (Figure 12)

This tool consists of a 12 volt light with leads. The ends of the leads usually have alligator clamps, but various kinds of probes, terminal spades, and special connectors are used also.

The unpowered test light is used on an open circuit. One lead of the test light is grounded and the other lead is moved around the circuit to find the open. Depending on the physical layout of the circuit, sometimes it will be easier to start at the power supply and other times it is easier to start at the circuit load or ground circuit.

POWERED TEST LIGHT (Figure 11)

This light is a pencil shaped unit with a self contained battery, a 1.5 volt light bulb, a sharp probe and a ground lead fitted with an alligator clip.

This test light is used mainly for testing components that are disconnected from the vehicle power supply. The power test light is also useful for testing suspected high resistance points in a circuit such as connectors and ground circuits that are corroded or loose.

JUMPER

The jumper is usually a long wire with alligator clamps. A version of the jumper has a fuse holder in it with a 10 Amp fuse. This will prevent damaging the circuit if the jumper is connected in the wrong way.

The jumper is used to locate opens in a circuit. One end of the jumper is attached to a power source and then the other end is attached to the load in the circuit, i.e.; light, motor. If the load works, try "jumping" to circuit points that are progressively closer to the power supply. When the circuit load stops working, the open has been located.

The jumper is also used to test components in the circuit such as connectors, switches, and suspected high resistance points.

NOTICE: The following instruments: Ammeter, Voltmeter, and Ohmmeter, each have a particular application for trouble shooting electrical circuits.

When using a ammeter or voltmeter, and the value being tested is unknown always use the highest scale first and work downward to a midscale reading whenever possible. This will avoid damage to the instrument.

Never use an ohmmeter in a power circuit, or as a substitute for a voltmeter or ammeter as damage to the instrument will result.

AMMETER (Figure 12 and 15)

Disconnect the circuit from the power source before connecting the ammeter. The ammeter measures the amount of electrical current, amperes, moving through a conductor. The ammeter must be placed in series with the circuit being tested. Be sure that the ammeter's positive terminal is connected to the positive (battery) side of the circuit and is negative terminal to the negative (ground) side of the circuit.

OHMMETER (Figure 13 and 15)

The ohmmeter is an instrument designed to indicate resistance in ohms. It is used to test the condition of a unit disconnected from the circuit.

Ohmmeter Calibration

When the ohmmeter probes are connected together, a circuit is completed causing the meter needle to deflect. The needle should read ZERO ohms, if it does not, rotate the CAL or ADJ knob to ZERO the needle.

When the probes are held apart, the needle moves to the maximum (infinite) resistance side of the scale.

The meter is now ready for use. Refer to figure 14 for a typical application of the ohmmeter.

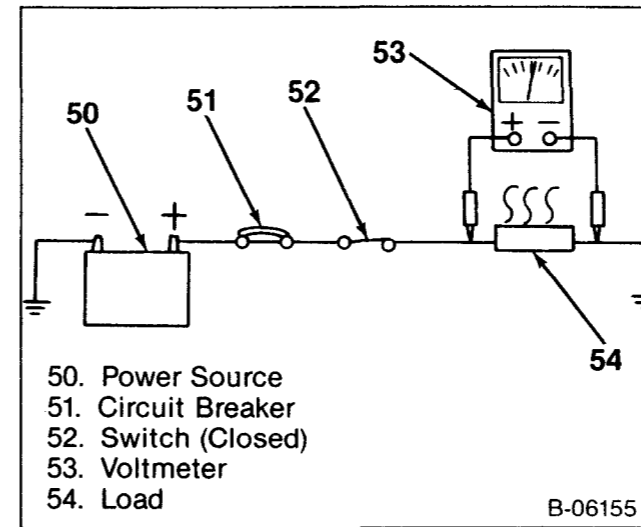

Figure 14—Voltmeter

VOLTMETER (Figures 14 and 15)

The voltmeter (properly observed) will give the technician more information than the ammeter, ohmmeter and test light combined. Its application for troubleshooting here is to measure the electrical pressure (voltage) drop in a resistance circuit (figure 14).

To use a voltmeter for troubleshooting an electrical problem, connect it in parallel with the existing circuit (figure 10). If the voltmeter is connected in series with the circuit being tested, the nature of the circuit would be changed and the reading would have no particular value or use. Connect the meter terminals according to polarity as shown in figure 14.

The dash mounted voltmeter (in the vehicle) should also be observed for monitoring proper operation of the generator battery cranking motor, and cranking circuit. In this application, battery voltage drop can be monitored while the engine is cranking; and after the engine is running, generator output voltage can be monitored. This can be a valuable first step prior to diagnosing other electrical problems.

WIRING HARNESS AND WIRES

Every wire is a specific size with colored or striped insulation that is indicated on the wiring diagrams. Insulation colors help to trace circuits and to make proper connections. Abbreviations and symbols used for indicating wire insulation colors and patterns are as follows:

- | | |
|------------------|------------------|
| BLK.Black | BLUBlue |
| BRN.Brown | PPLPurple |
| CHK.Check | TRTracer |
| CRCross | YELYellow |
| GRN.Green | //Parallel |
| NATNatural | WHTWhite |
| SGLSingle | STRStripe |
| ORNOrange | PNKPink |
| GRGray | DKDark |

Some wires are grouped and taped together or encased in a split plastic casing. This grouping of wires is called a harness. For some purposes, it is more practical to use a single wire protected by a braided tubing called a loom.

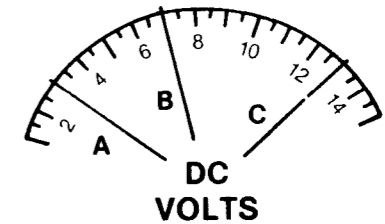

VOLTMETER SCALE: 0 Volts through 15 Volts

- A = 3 Volts
- B = 7 Volts
- C = 13 Volts

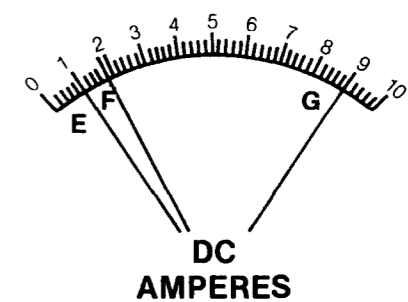

AMMETER SCALE: 0 Amperes through 10 Amperes

- E = 1 Ampere
- F = 1.8 Amperes
- G = 9 Amperes

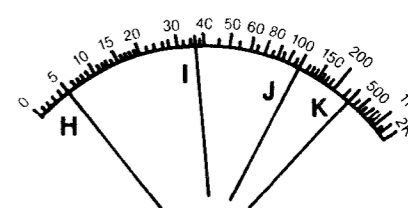

OHMMETER SCALE: 0 Ohms through Infinity (∞)

- H = 5 Ohms
- I = 36 Ohms
- J = 115 Ohms
- K = 350 Ohms

F-01778

Figure 15—Meter Scales

Wiring harnesses are joined by using a multiple plug and receptacle connector block, or a terminal post chassis junction block. In the instrument panel area plastic insulated blade-type connectors and screw-type terminals are used.

Each harness or wire must be held securely in place by clips or other holding devices to prevent chafing of the insulation.

WIRE SIZE

Wire size in a circuit is determined by the amount of current, the length of the circuit and the voltage drop allowed. Wire size is specified using the metric gage. The metric gage describes the wire size directly in cross section area measured in square millimeters.

WIRE SIZE CONVERSION TABLE

METRIC SIZE (mm) ²	AWG SIZE
0.22	24
0.35	22
0.5	20
0.8	18
1.0	16
2.0	14
3.0	12
5.0	10
8.0	8
13.0	6
19.0	4
32.0	2
40.0	1
50.0	0
62.0	00

ON-VEHICLE SERVICE

CIRCUIT MAINTENANCE AND REPAIR

MAINTENANCE AND REPAIR

All electrical connections must be kept clean and tight. Loose or corroded connections may cause a discharged battery, difficult starting, dim lights, and possible damage to the generator and regulator. Wires must be replaced if insulation becomes burned, cracked, or deteriorated.

To splice a wire or repair one that is frayed or broken always use rosin flux solder to bond the splice and insulating tape to cover all splices or bare wires.

When replacing wire, it is important that the correct size wire be used as shown on applicable wiring diagrams or parts book. Each harness or wire must be held securely in place to prevent chafing or damage to the insulation due to vibration.

Never replace a wire with one of a smaller size or replace a fusible link with a wire of a larger size.

WIRING CONNECTOR TERMINAL REPLACEMENT (BLADE TYPE)

Remove or Disconnect (Figure 16)

1. Terminal lock tang.
2. Terminal (61).

Install or Connect (Figure 17)

1. Pry up on the tang (70).
2. Terminal into the connector.

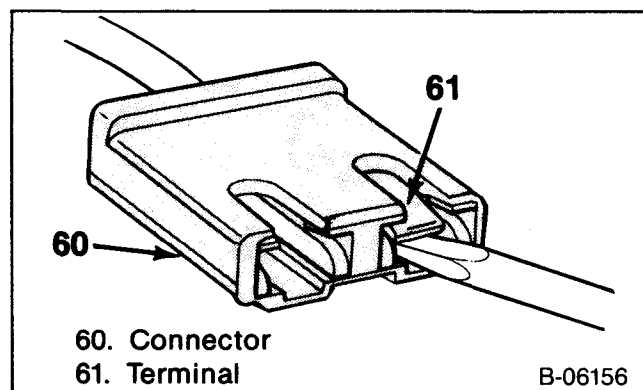

Figure 16—Removing the Terminals from the Connector

WIRING CONNECTOR TERMINAL REPLACEMENT (TWIN LOCK TYPE)

Remove or Disconnect (Figure 18)

Tool Required:

J-22727 Terminal Remover

1. Connector lock tangs.
2. Terminal locks using J-22727.
3. Terminal.

Install or Connect

1. Pry out the tangs.
2. Terminal into the connector.

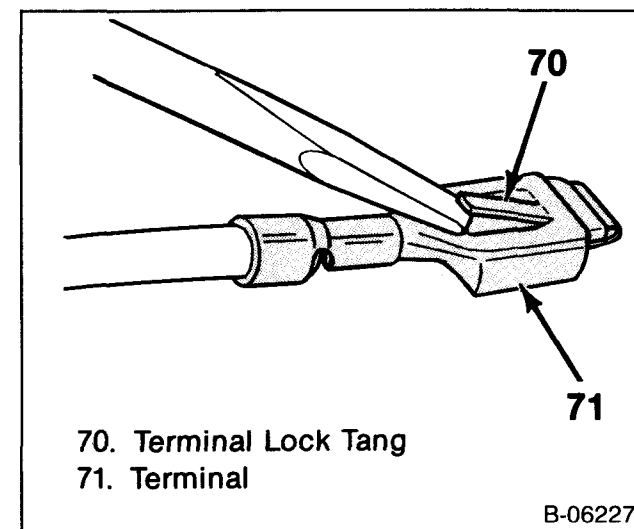

Figure 17—Resetting the Lock Tang

WEATHER-PACK CONNECTORS

Special connectors known as Weather-Pack connectors (figure 19) require a special tool J-28742 for servicing. This special tool is required to remove the pin and sleeve terminals. If removal is attempted with an ordinary pick, there is a good chance that the terminal will be bent or deformed. Unlike standard blade-type terminals, these terminals cannot be straightened once they are bent.

Make sure that the connectors are properly seated and all of the sealing rings in place when connecting the leads. The hinge-type flap provides a back-up, or secondary locking feature for terminals. They are used to improve the connector reliability by retaining the terminals if the small terminal lock tangs are not positioned properly.

Molded-on-connectors require complete replacement of the connection. This means splicing a new connector assembly into the harness. Environmental connections cannot be replaced with standard connections. Instructions are provided with the Weather-Pack connector and terminal packages.

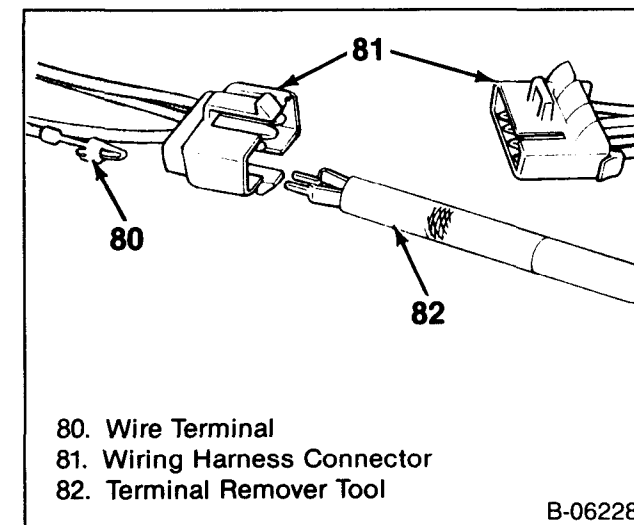

Figure 18—Twin Lock Connector Terminal

With the low current and voltage levels found in some circuits, it is important that the best possible bond at all wire splices be made by soldering the splices.

Use care when probing the connections or replacing terminals in them, it is possible to short between opposite terminals. If this happens to the wrong terminal part, it is possible that damage may be done to certain components. Always use jumper wires between connectors for circuit checking. Never probe through the Weather-Pack seals.

When diagnosing for possible open circuits, it is often difficult to locate them by sight because oxidation or terminal misalignment are hidden by the connectors. Merely wiggling a connector on a sensor or in the wiring harness may correct the open circuit condition. This should always be considered when an open circuit is indicated while troubleshooting. Intermittent problems may also be caused by oxidized or loose connections.

METRI-PACK CONNECTORS

The Metri-Pack connectors use a pull-to-seat type terminal, as shown in figure 19. The special tool required to remove the terminal is J-35689-A terminal remover. If removal is attempted with an ordinary pick, there is a good chance that the terminal will be bent or deformed. Refer to figure 19.

Remove or Disconnect (Figure 19)

Tool Required:

J-28742 Terminal Remover

1. Primary lock (121) by lifting.
2. Connector sections.
3. Secondary lock (125) by spreading the sides of the hasp, thus clearing the staples and rotating the hasp (127).
4. Terminal (131) by using J-28742 (128).
 - Snip off the old terminal assembly.
5. 5 mm of the wire insulation (130).

Clean

- Terminal barrel (124).

Install or Connect (Figure 19)

1. Terminal insulator (134) on the wire. Slide the insulator back on the wire about 8 cm (3 inches).
2. Terminal (131) on the wire.
 - Roll crimp (132) and solder the terminal.
3. Terminal insulator (134) and the roll crimp (133).
4. Terminal into the connector.
5. Secondary lock (125).
6. Connector sections until the primary lock (121) engages.

METRI-PACK CONNECTOR REPLACEMENT

Remove or Disconnect (Figure 19)

Tool Required

J-35689-A Terminal Remover

1. Primary lock (121) by lifting.
2. Connector body (137).
3. Connector seal (120) by pulling the seal back onto the wires away from the connector body (137).

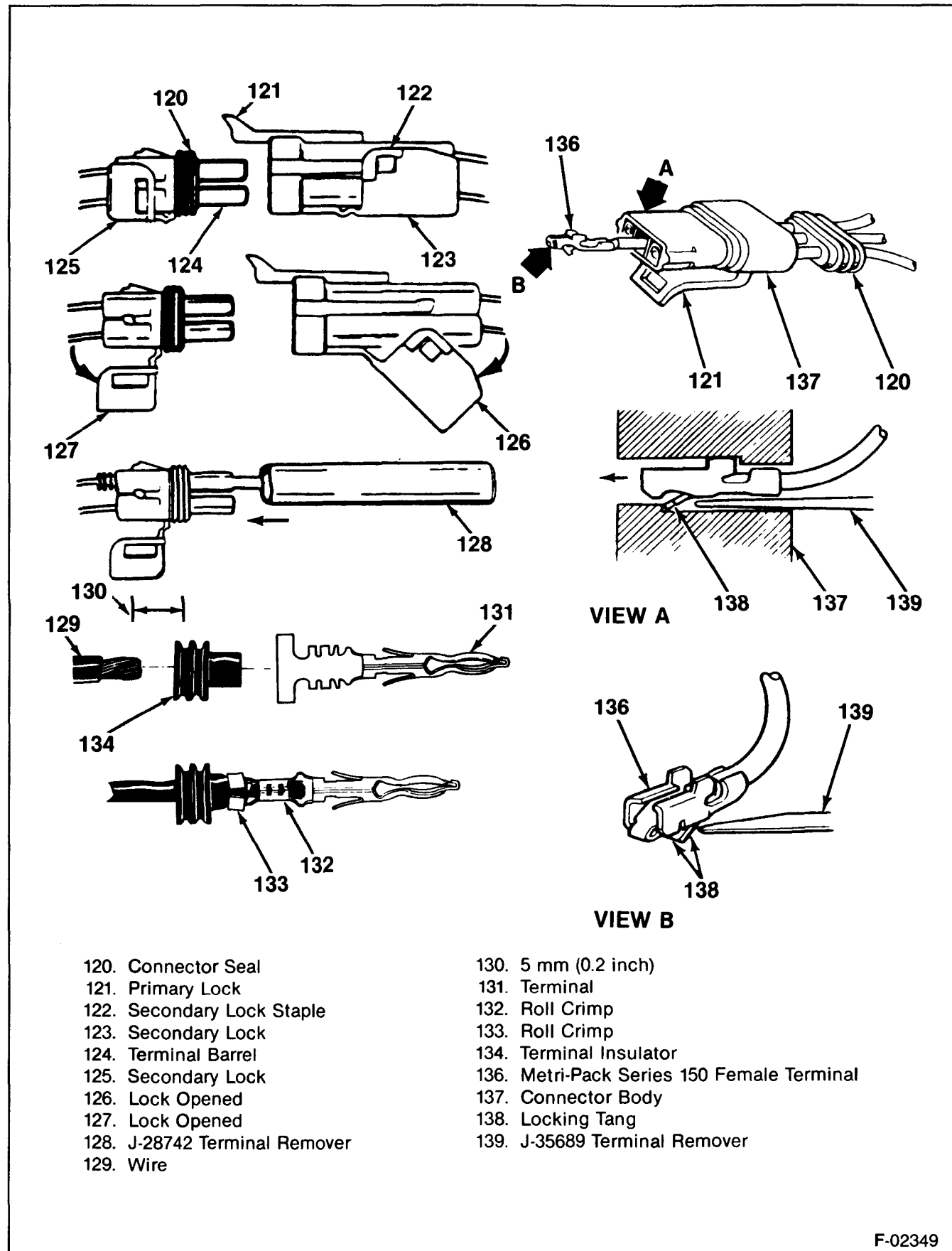
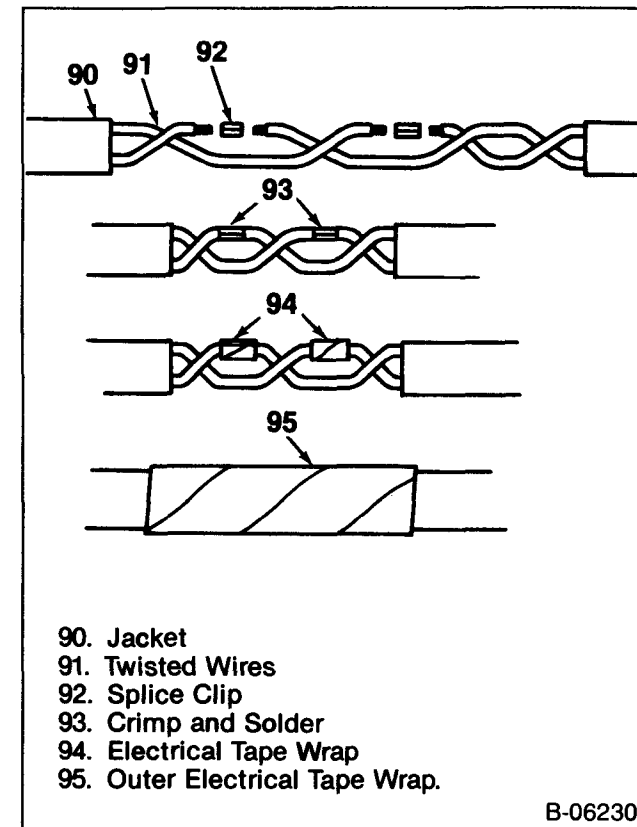

Figure 19—Weather-Pack and Metri-Pack Connectors

F-02349



B-06230

Figure 20—Twisted Wire Repair

4. Terminal (136) by inserting J-35689 (139) into the connector body (137) to depress the locking tang (138), then push the wire and terminal through the connector body (figure 20).
- Snip off the old terminal unless the terminal is to be reused, reshape the locking tang.
5. 5 mm (0.2-inch) of the wire insulation (130).

Clean

- Terminal cavity of the connector body.

Install or Connect (Figure 19)

1. Terminal (136) on the wire.
- Crimp and solder the terminal.
2. Terminal (136) into the connector cavity by pulling the wire on the seal side of the connector until the locking tang (138) is fully seated.
3. Seal (120) by pressing the seal into the connector body (137) until it is fully seated.
4. Connector until the primary lock (121) engages.

WIRING REPAIR

The wire repair is very important for the continued reliable operation of the vehicle. This repair must be done as described in the following procedures.

Twisted Wires (Figure 20)

Remove or Disconnect

1. Jacket (90).
2. Twisted wires (91).

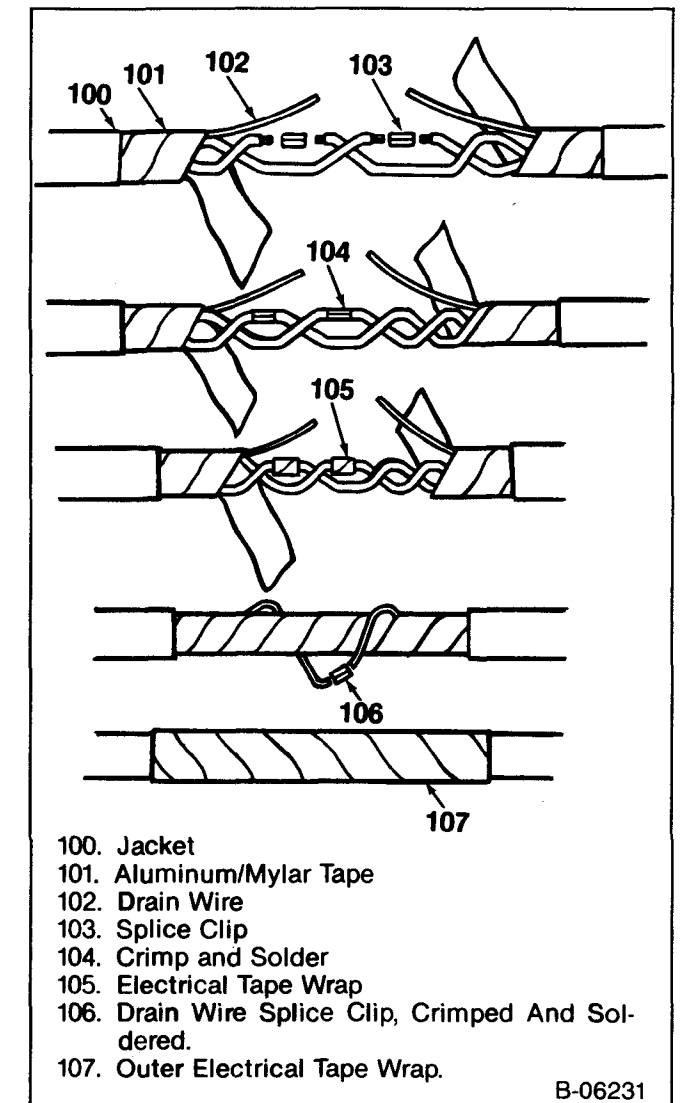

B-06231

Figure 21—Twisted/Shielded Wire Repair

3. Insulation from the wire.

Install or Connect

1. Splice clip (93).
- Crimp.
- Solder.
2. Electrical tape wrap (94) on wires.
3. Outer electrical tape wrap (95).

Twisted Wires/Shielded Cable (Figure 21)

Remove or Disconnect

1. Jacket (100).
2. Unwrap aluminum/mylar tape (101).
3. Drain wire (102).
4. Leads.
5. Insulation on the leads.

Install or Connect

1. Splice clips (103).
2. Crimp and solder the splice clips (104).
3. Electrical tape (105) on the splices.

4. Aluminum/mylar tape by wrapping and taping.
5. Drain wire with a splice clip (106). Crimp and solder the splice clip.
6. Outer jacket electrical tape wrap (107).

SPECIAL TOOLS

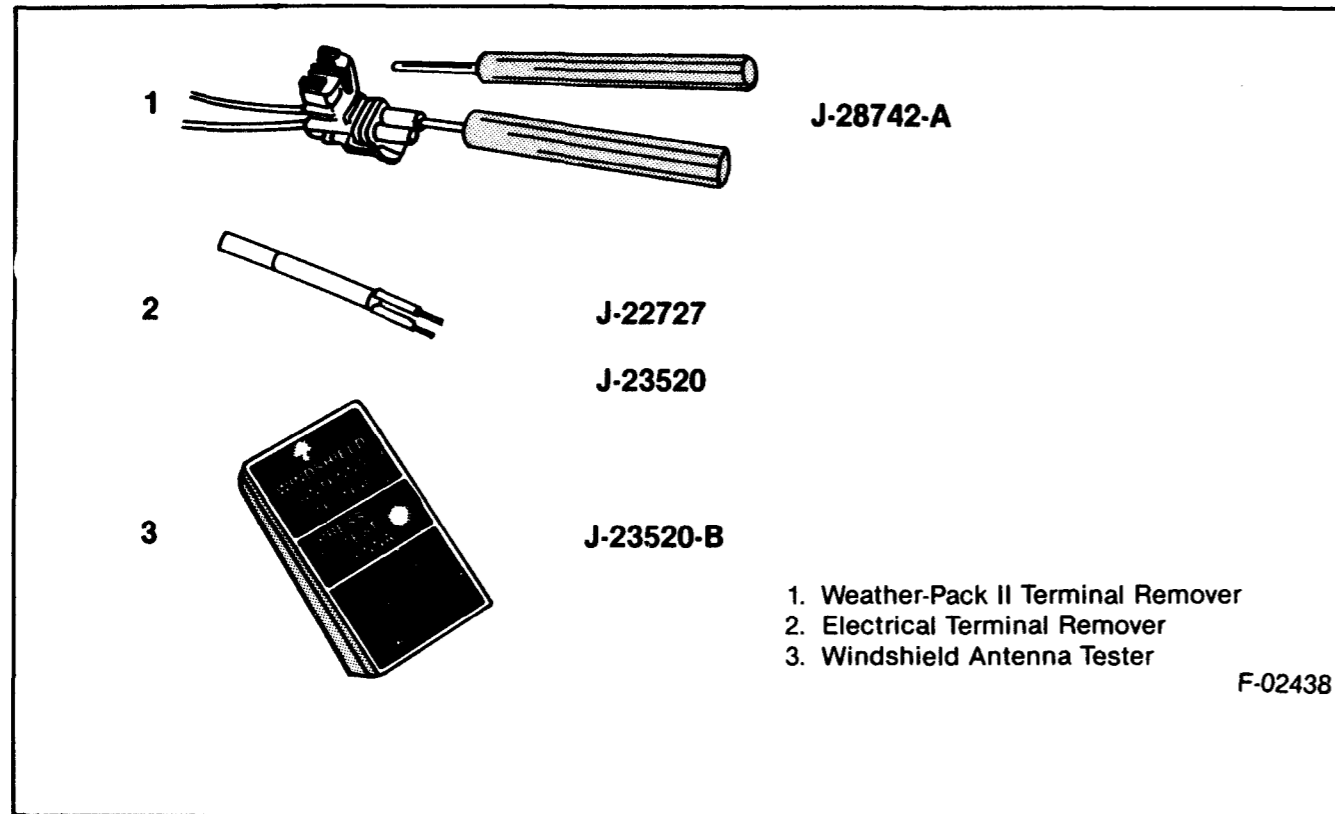

1988 C/K TRUCK

SECTION A

<u>PAGE</u>	<u>DESCRIPTION</u>	<u>PAGE</u>	<u>DESCRIPTION</u>
2	POWER DISTRIBUTION (GASOLINE)	34	ELECTRONIC CONTROL MODULE (ECM)—OUTPUTS (DIESEL)
3	POWER DISTRIBUTION (DIESEL)	36	ECM CHART (DIESEL)
4	AUXILIARY BATTERY (RPO TP2)	38	AUTO TRANSMISSION KICKDOWN SOLENOID (M40)
5	FUSE BLOCK	39	HEATER
6	CONVENIENCE CENTER	40	AIR CONDITIONING
7	HEADLAMPS & PARKING LAMPS (BASE)	42	BRAKE WARNING SYSTEM
8	HEADLAMPS & PARKING LAMPS (QUAD)	43	INSTRUMENT PANEL LAMPS (ELECTRONIC)
9	MARKER LAMPS (QUAD ONLY)	44	INDICATOR LAMPS (ELECTRONIC)
11	ROOF MARKER LAMPS	46	SEAT BELT WARNING BUZZER
12	HAZARD LAMPS	47	FOUR WHEEL DRIVE INDICATOR
14	DIRECTIONAL LAMPS	48	DOME LAMPS
16	HORNS	49	CONVENIENCE LIGHTING PACKAGE
17	START	50	CARGO LAMP
18	START (DIESEL)	51	RADIO EQUIPMENT
19	IGNITION	52	RADIO EQUIPMENT
20	THROTTLE BODY INJECTION	53	POWER WINDOWS
21	HOT FUEL HANDLING	54	REAR DEFOGGER
22	GLOW PLUGS (DIESEL)	55	POWER DOOR LOCKS
24	ENGINES CONTROLS (DIESEL)	56	WIPER/WASHER
26	FUEL CONTROL & IDLE AIR CONTROL	57	CRUISE CONTROL
27	AUXILIARY COOLING FAN	58	REAR WHEEL ANTI-LOCK
29	ELECTRONIC CONTROL MODULE (ECM)—INPUTS	59	BACK-UP LAMPS
30	ELECTRONIC CONTROL MODULE (ECM)—OUTPUTS	61	END GATE & SIDE CLEARANCE LAMPS
32	ECM CHART	62	TAIL LAMPS
33	ELECTRONIC CONTROL MODULE (ECM)—INPUTS (DIESEL)	64	LICENSE LAMPS

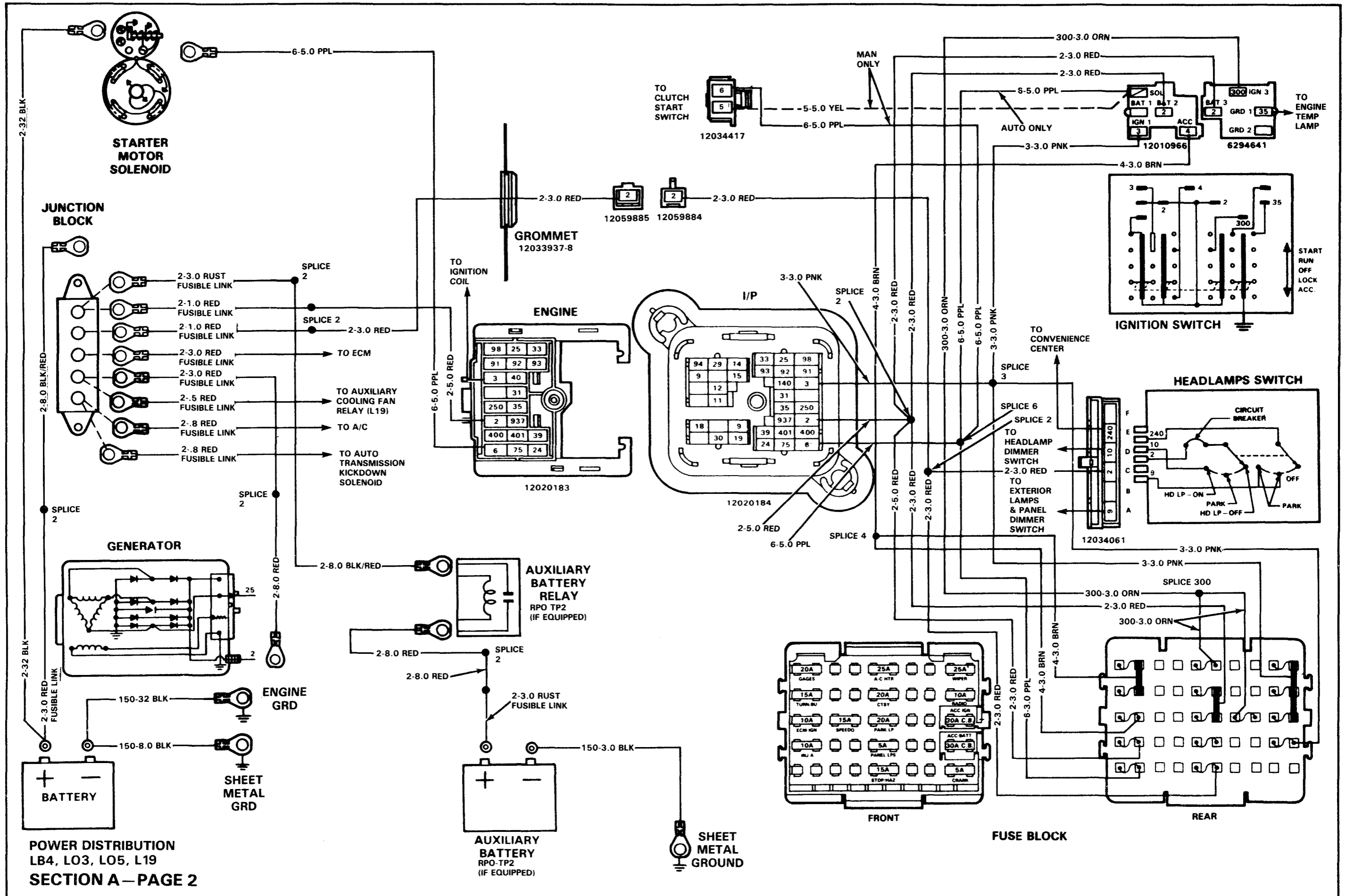

POWER DISTRIBUTION
LB4, LO3, LO5, L19
SECTION A - PAGE 2

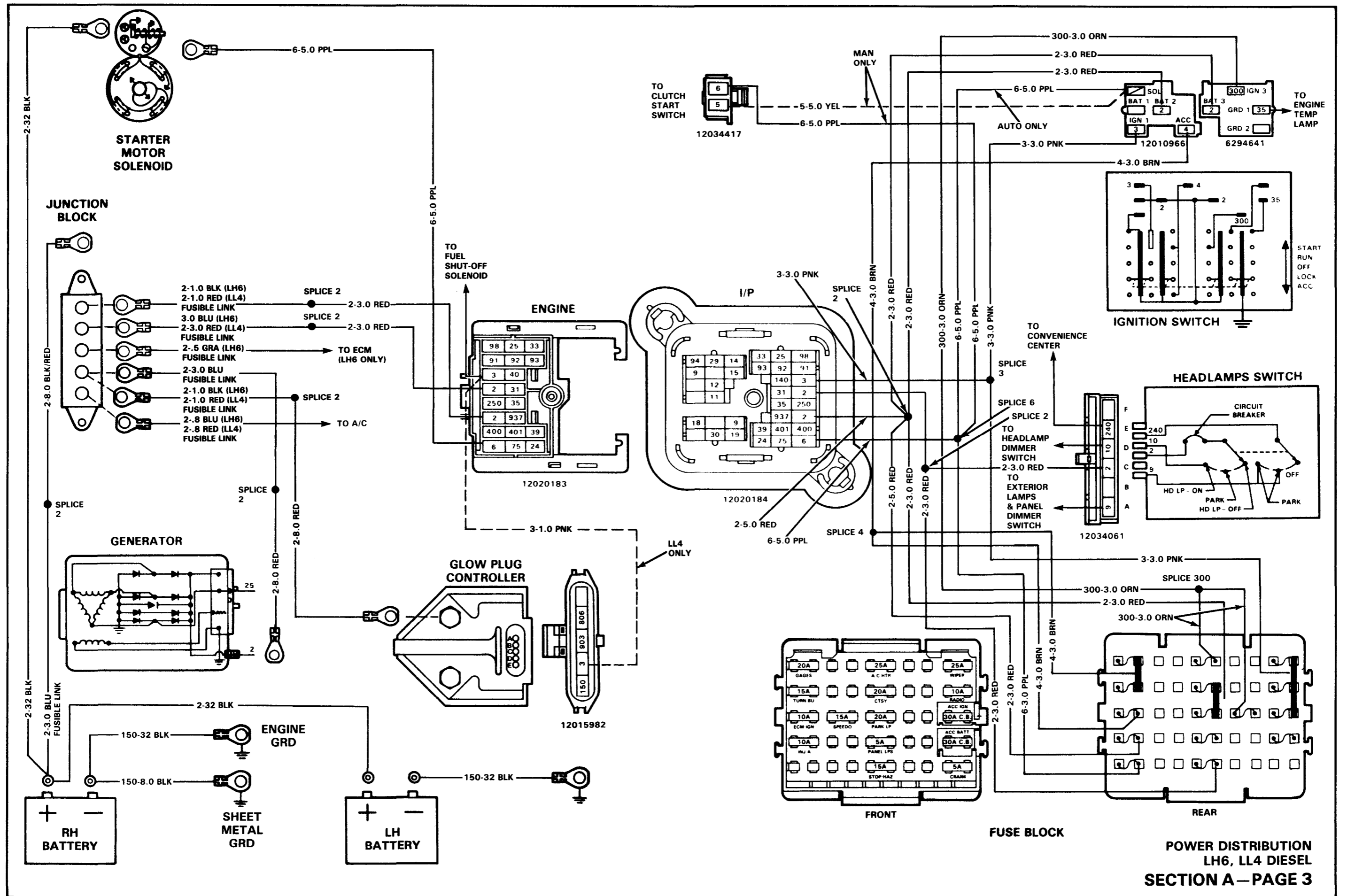

STARTER MOTOR SOLENOID

JUNCTION BLOCK

GENERATOR

GLOW PLUG CONTROLLER

ENGINE

I/P

HEADLAMPS SWITCH

FRONT

FUSE BLOCK

REAR

POWER DISTRIBUTION
LH6, LL4 DIESEL
SECTION A - PAGE 3

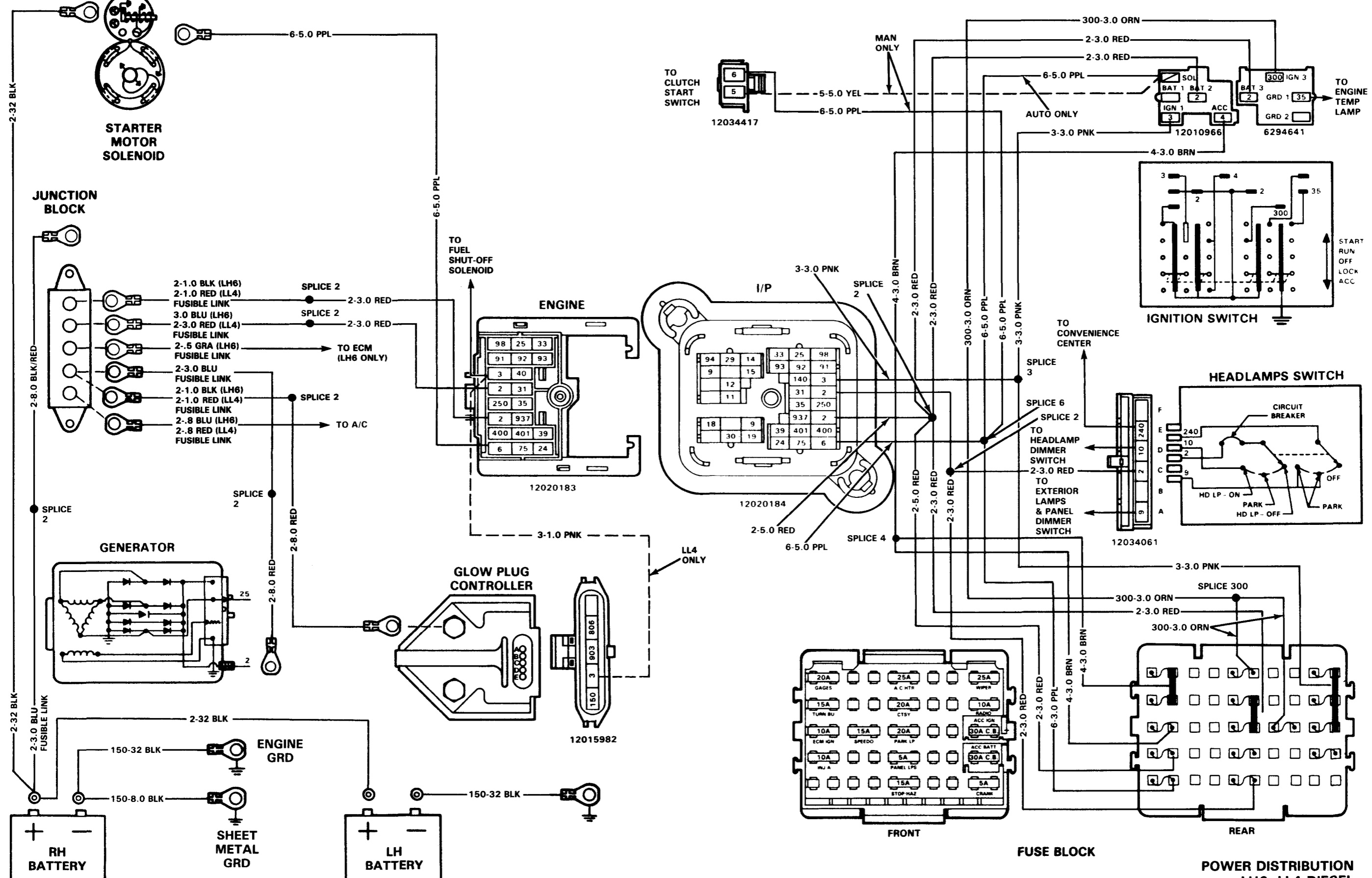

STARTER MOTOR SOLENOID

JUNCTION BLOCK

GENERATOR

GLOW PLUG CONTROLLER

ENGINE

I/P

HEADLAMPS SWITCH

FRONT

FUSE BLOCK

REAR

POWER DISTRIBUTION
LH6, LL4 DIESEL
SECTION A - PAGE 3

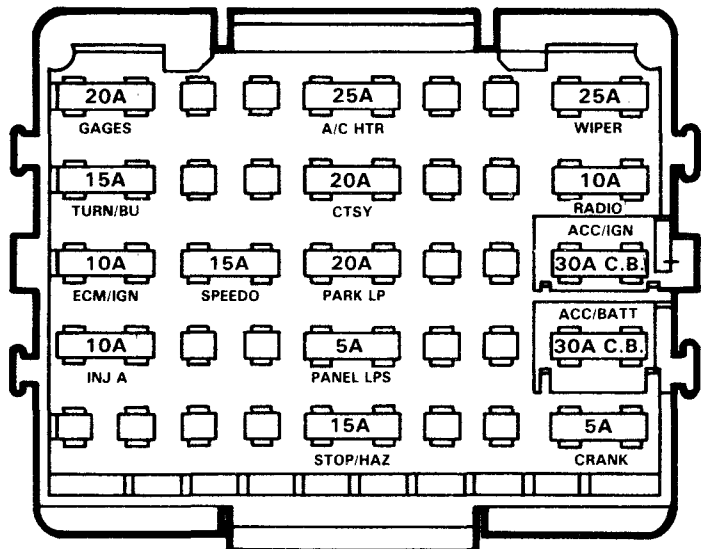

FRONT

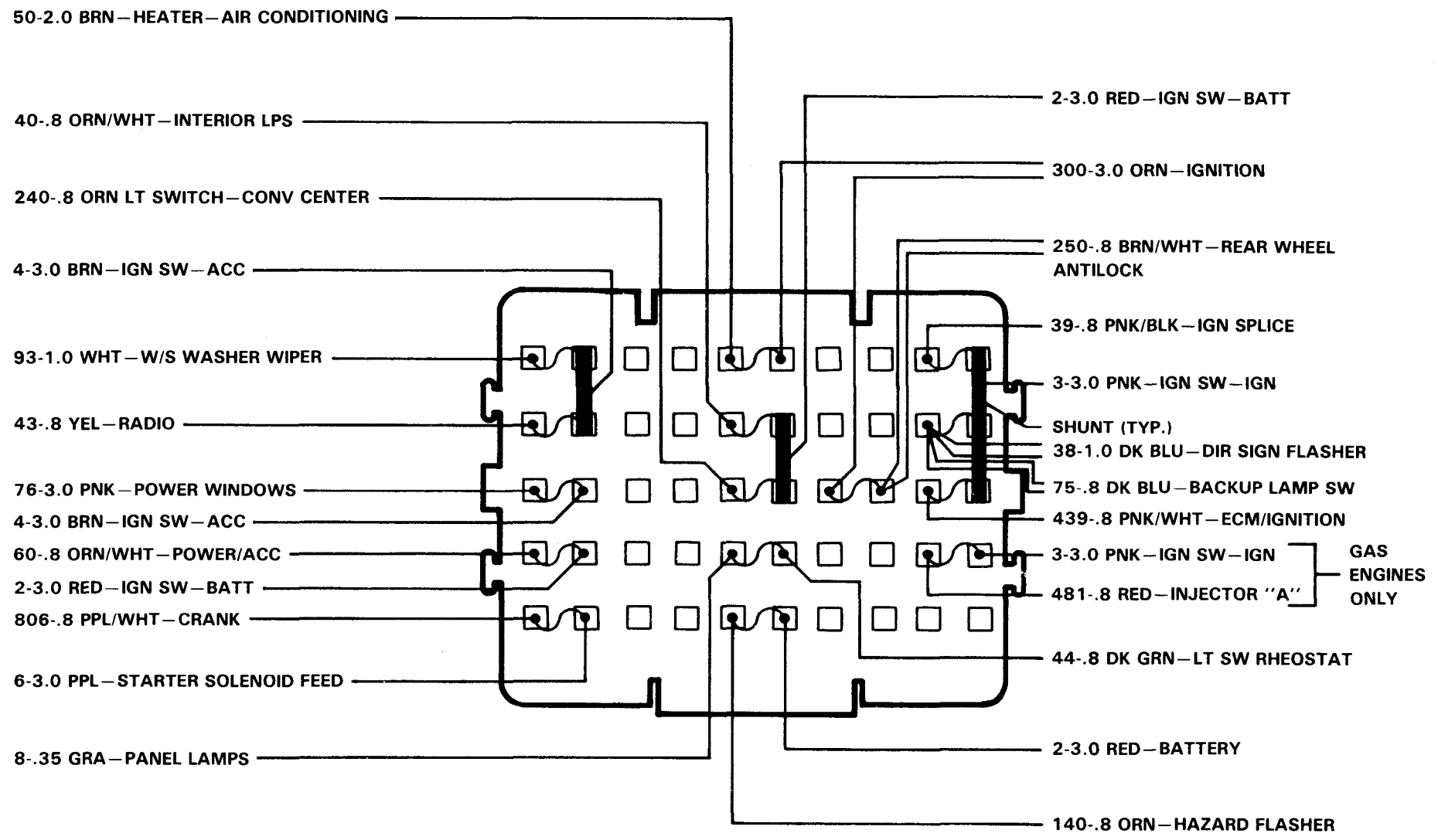

REAR

FUSES	AMP	COLOR
12004005	5	TAN
12004007	10	RED
12004008	15	LT BLU
12004009	20	YEL
12004010	25	WHT

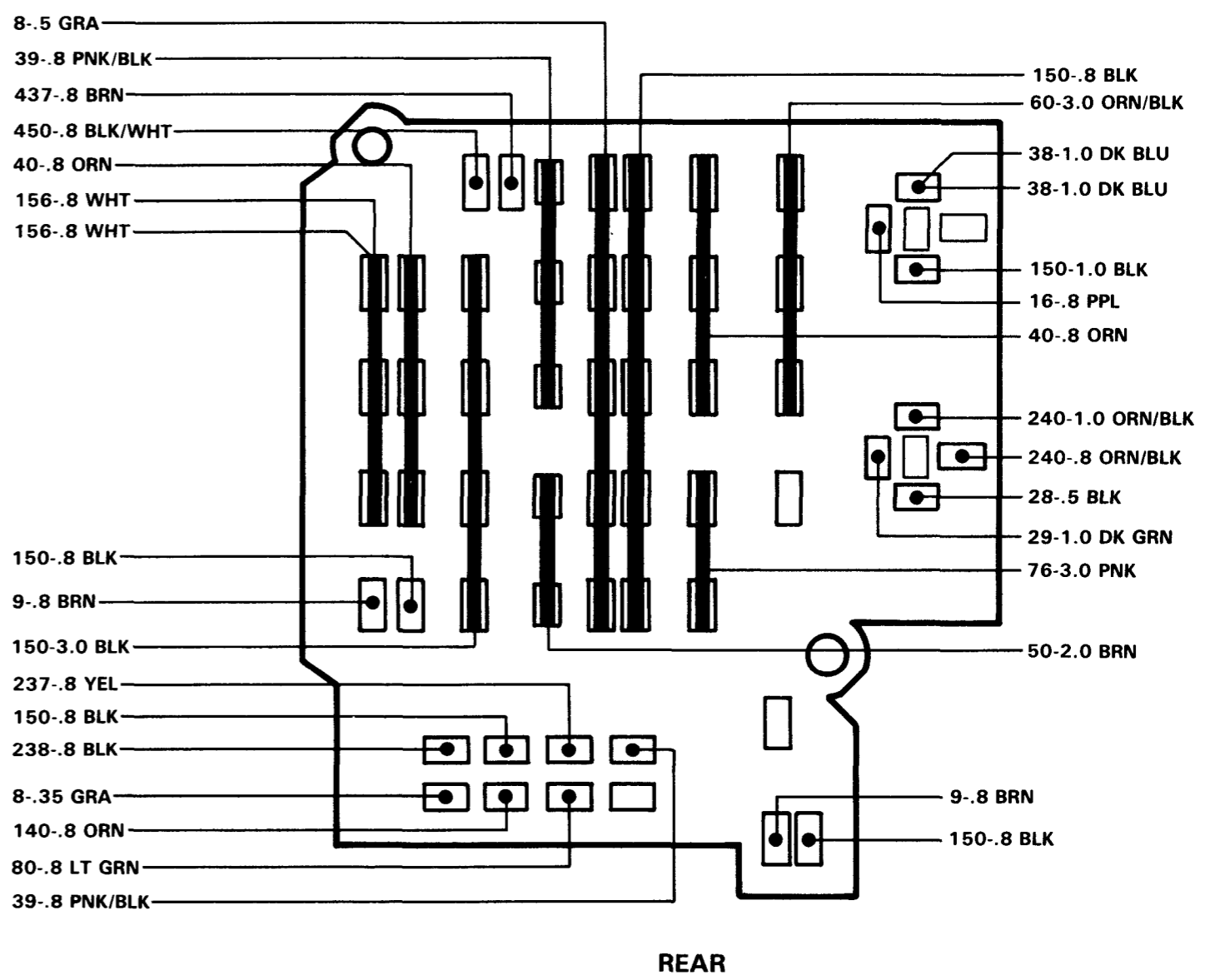
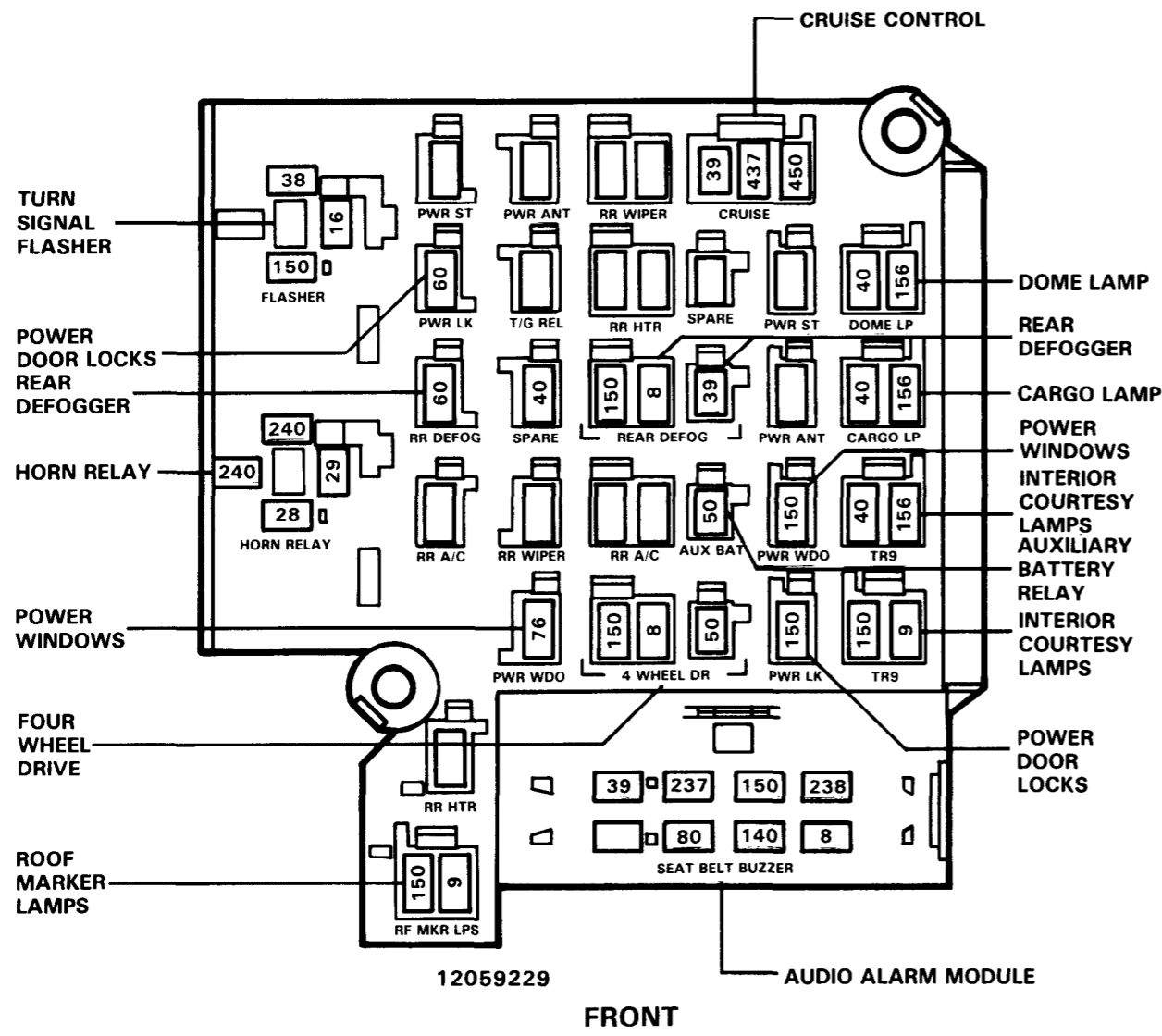

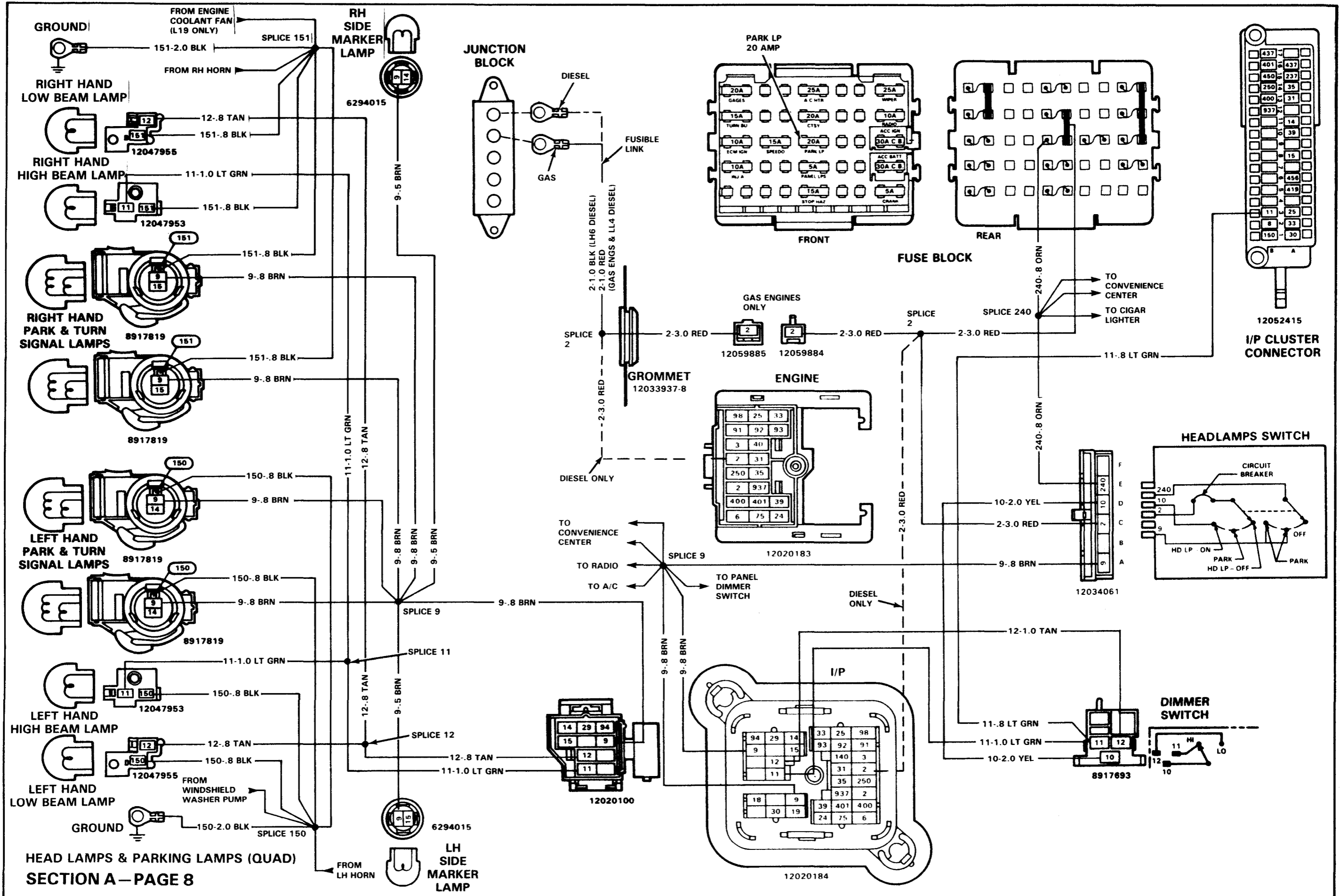

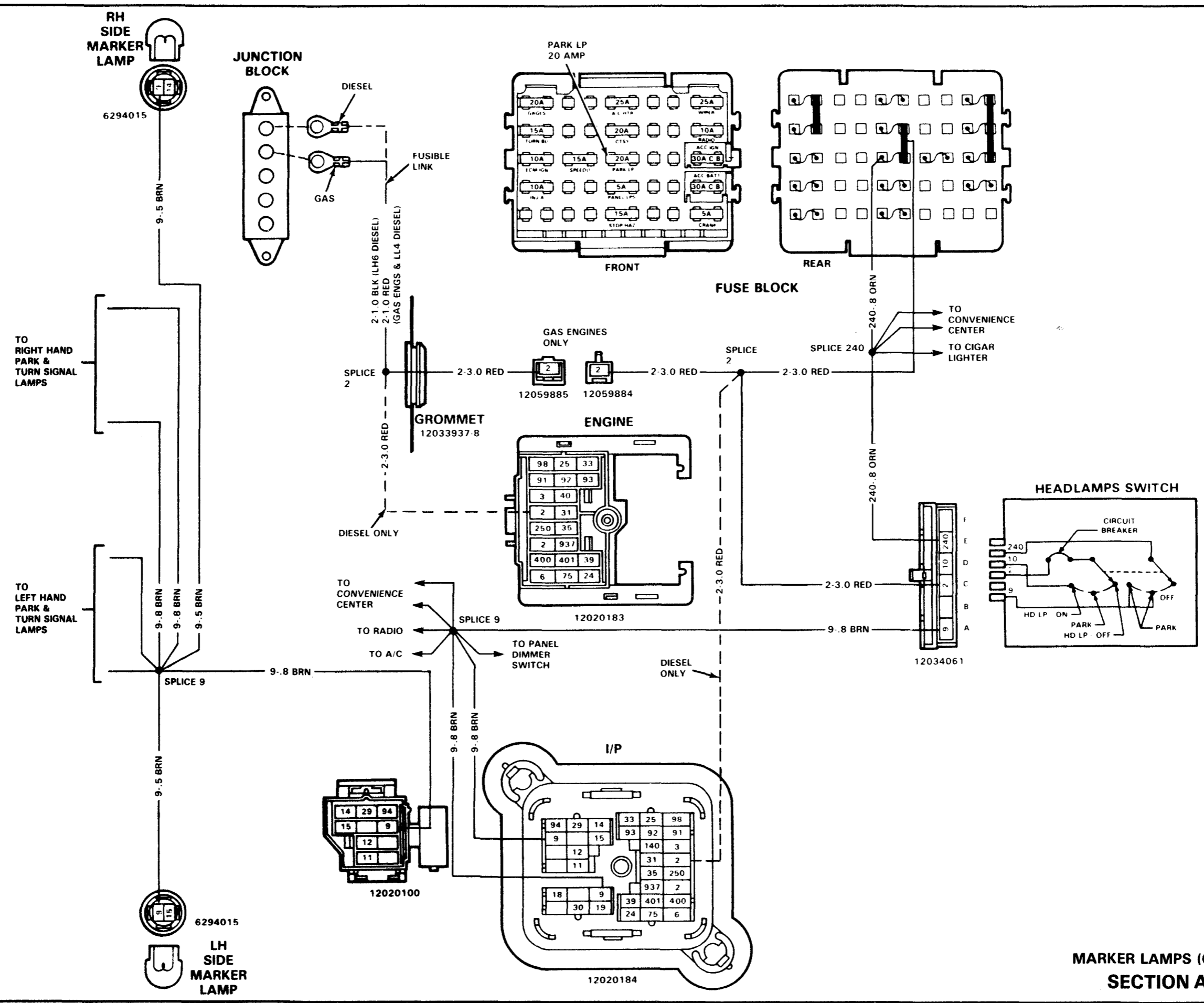

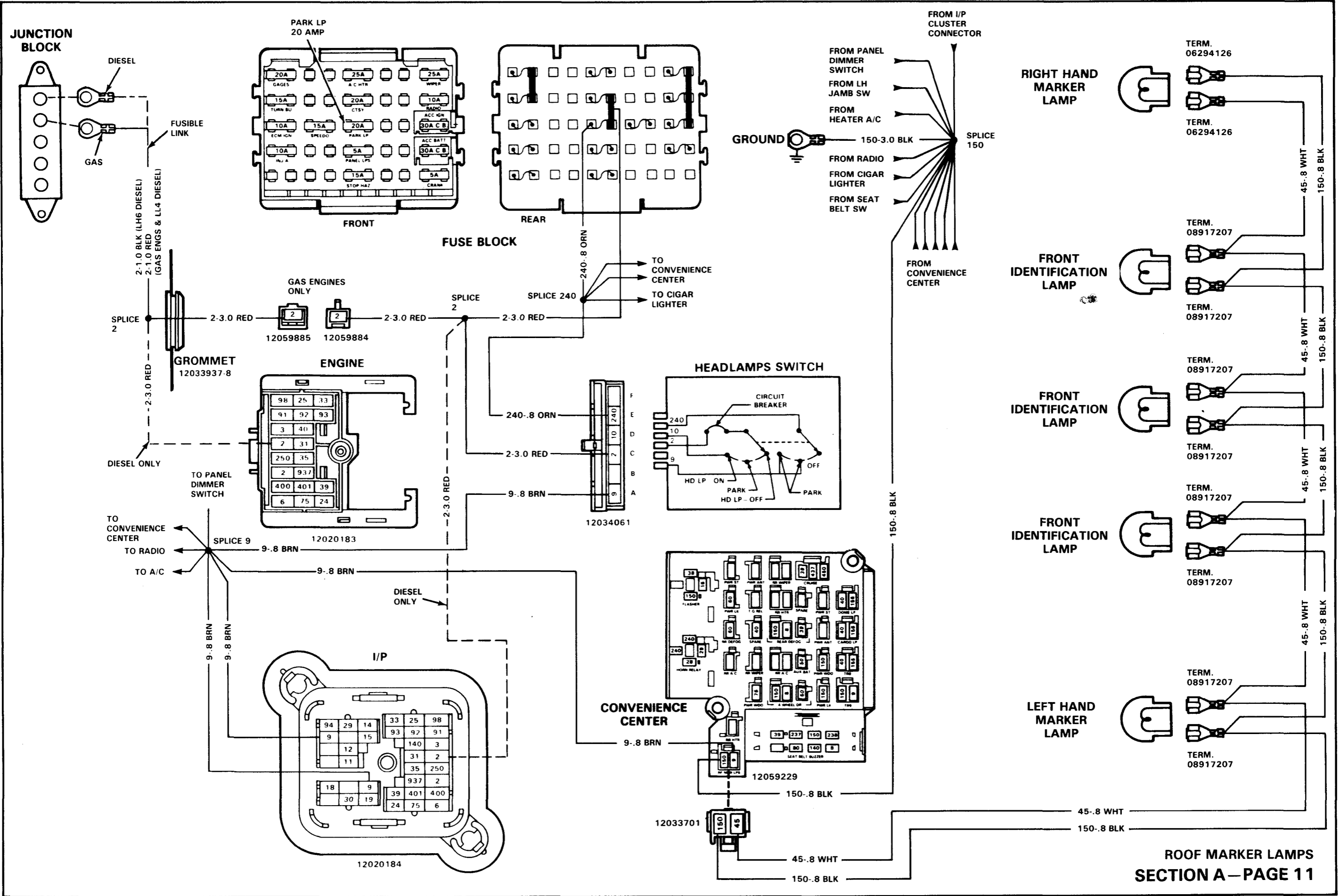

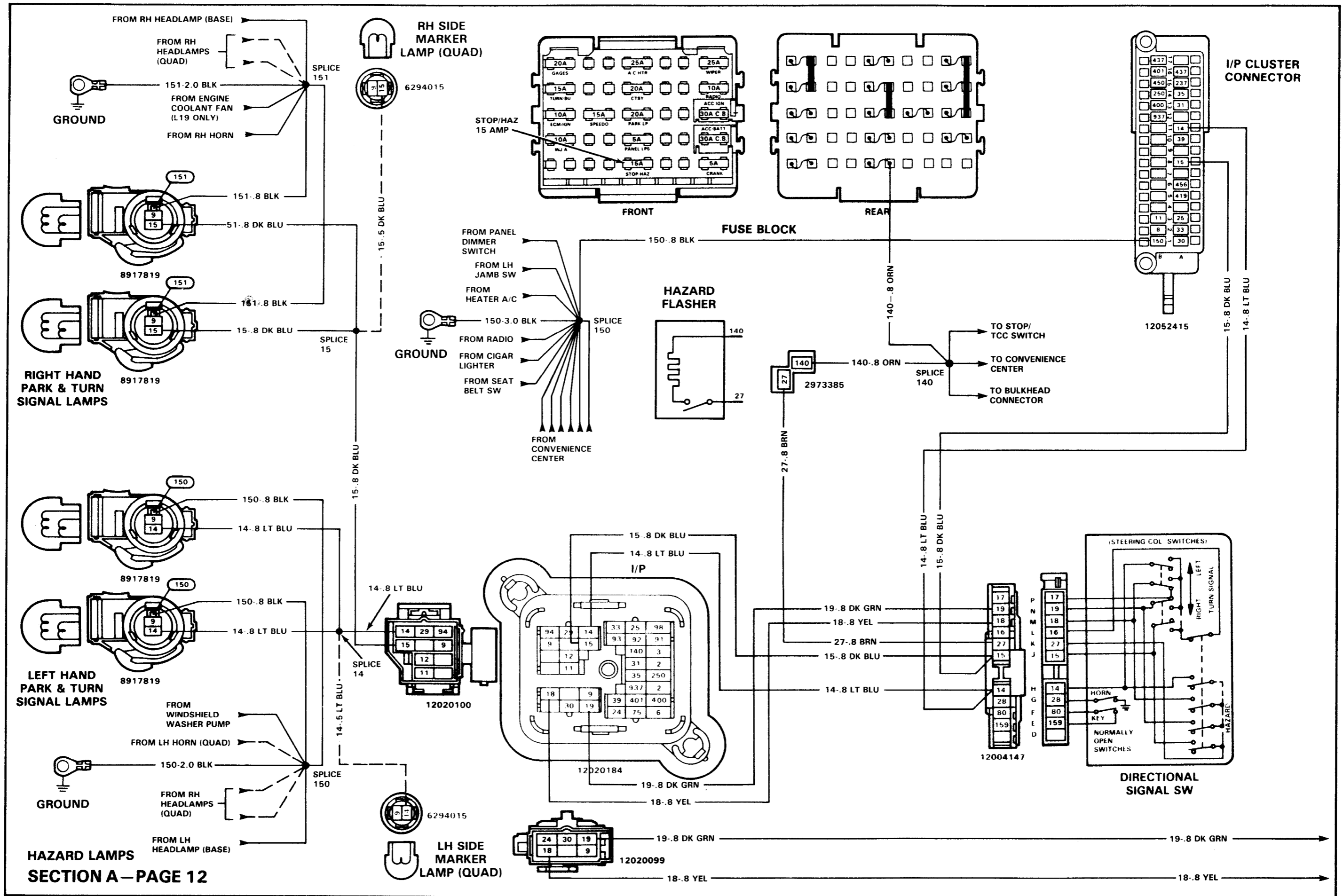

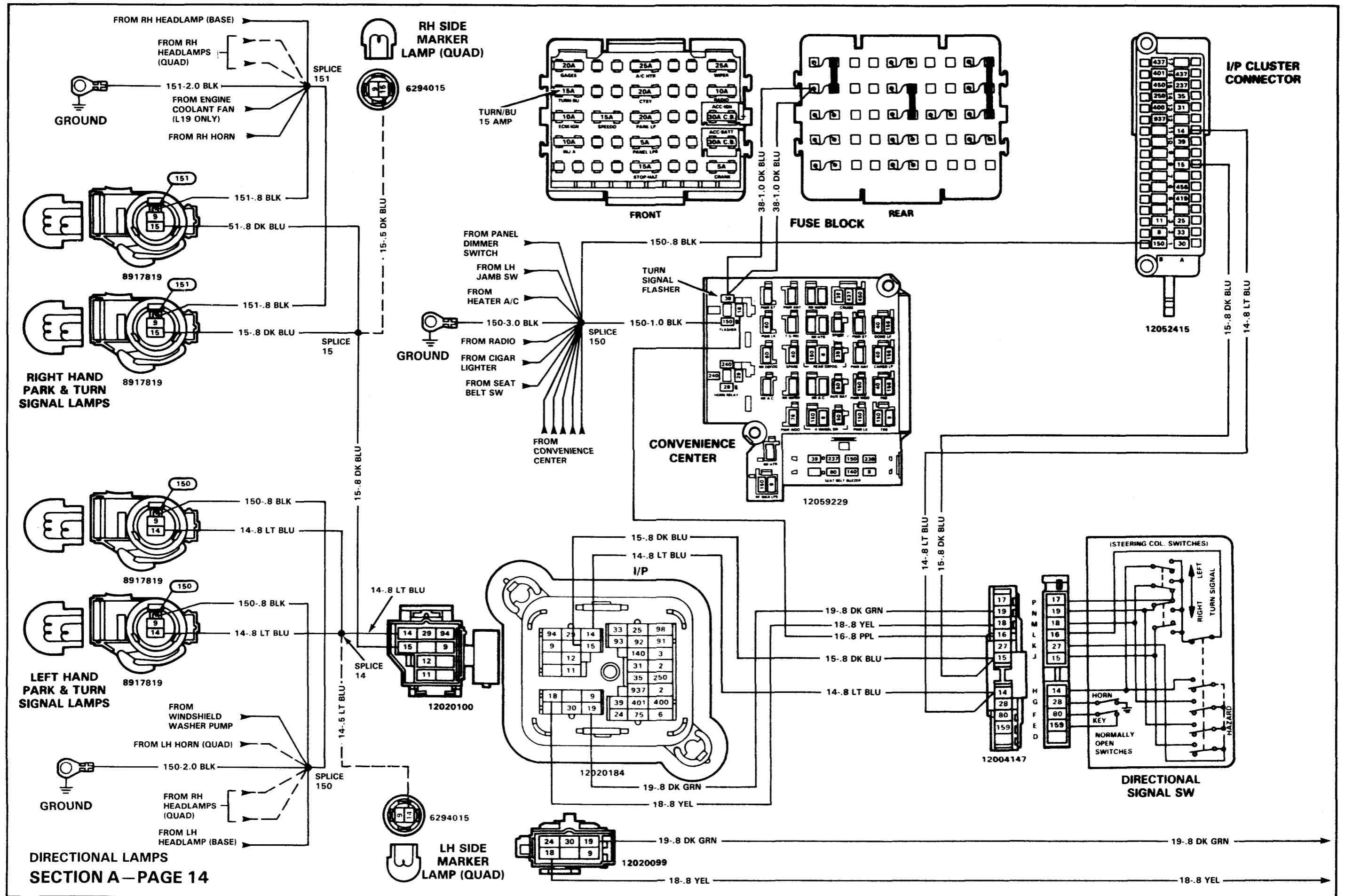

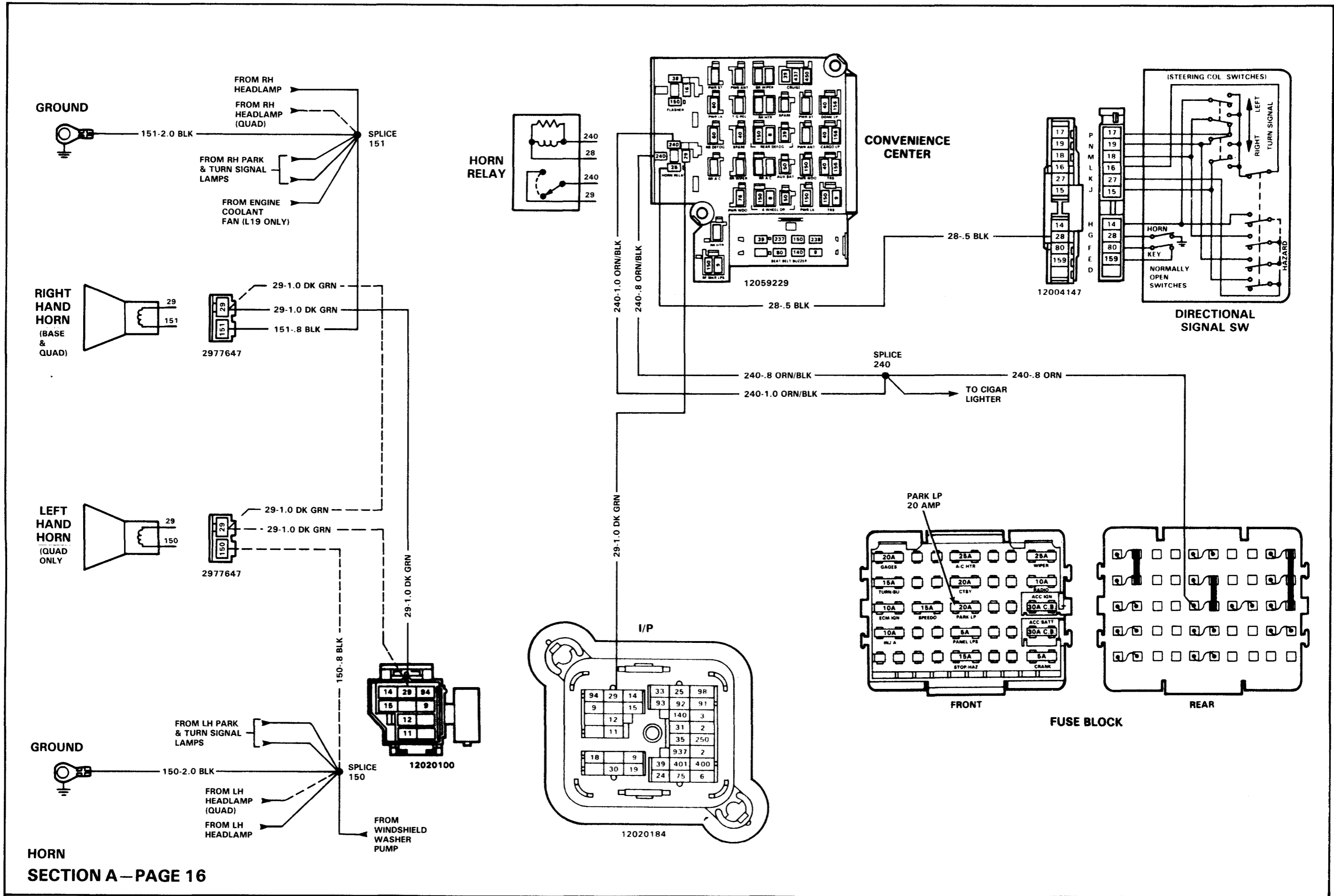

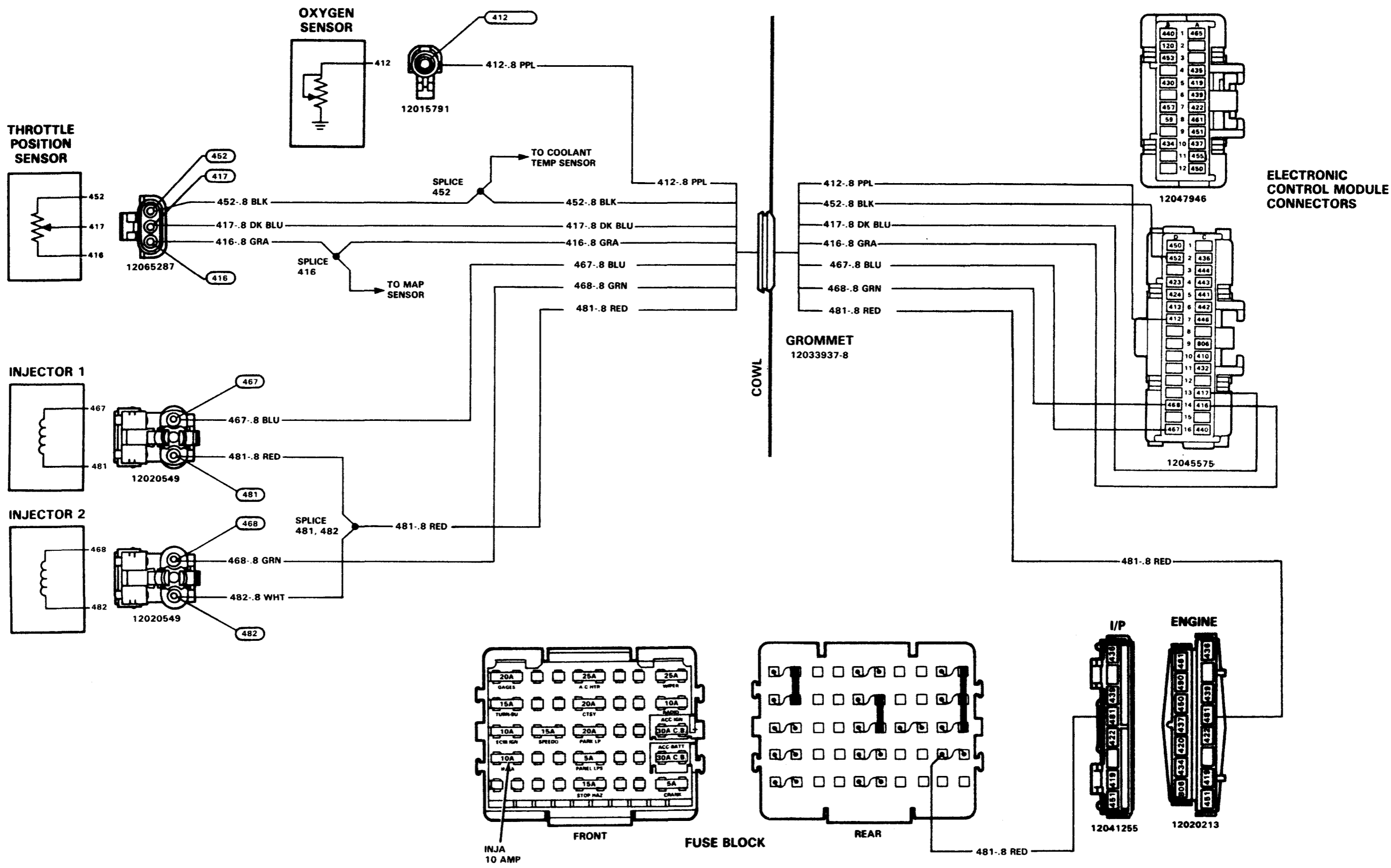

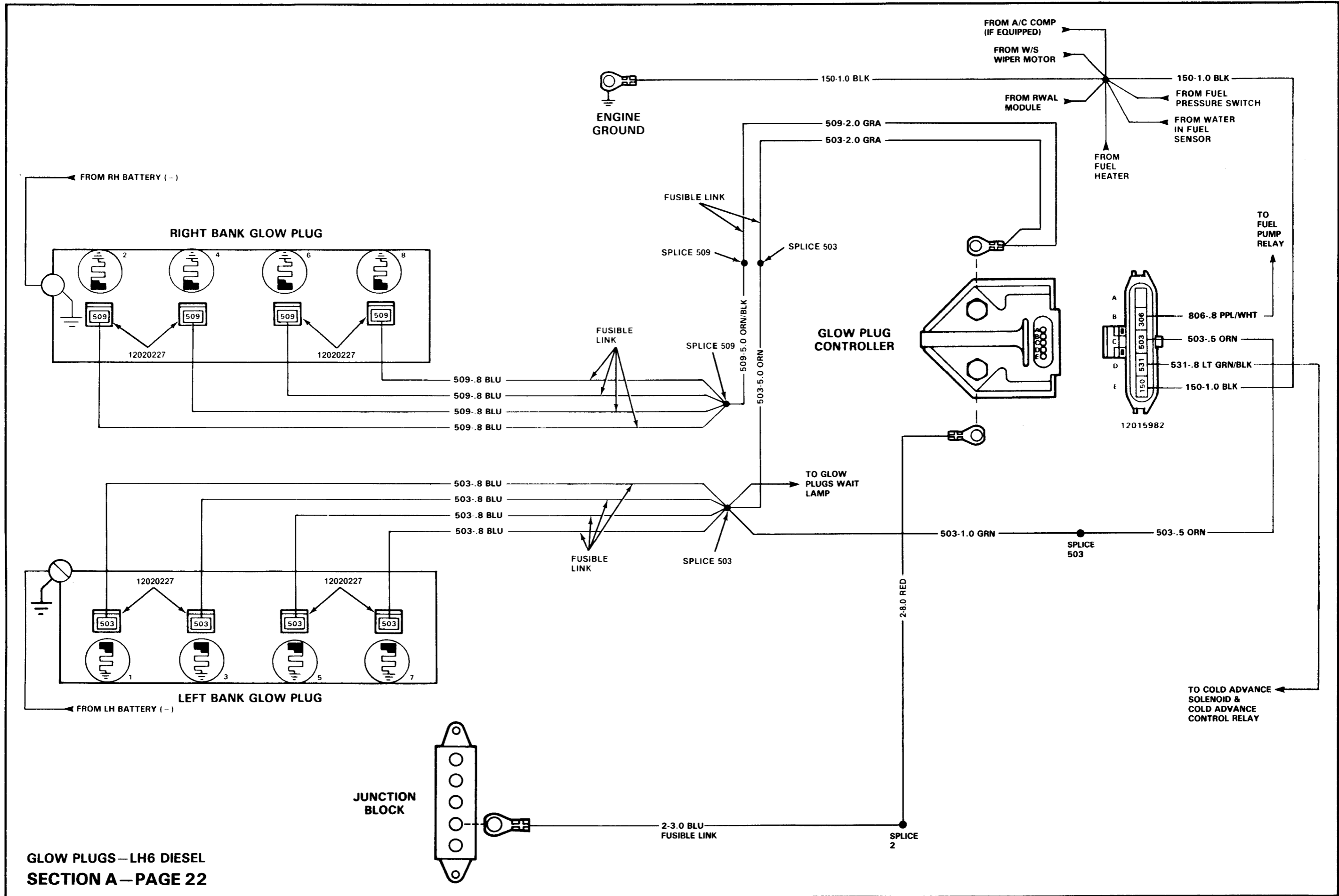

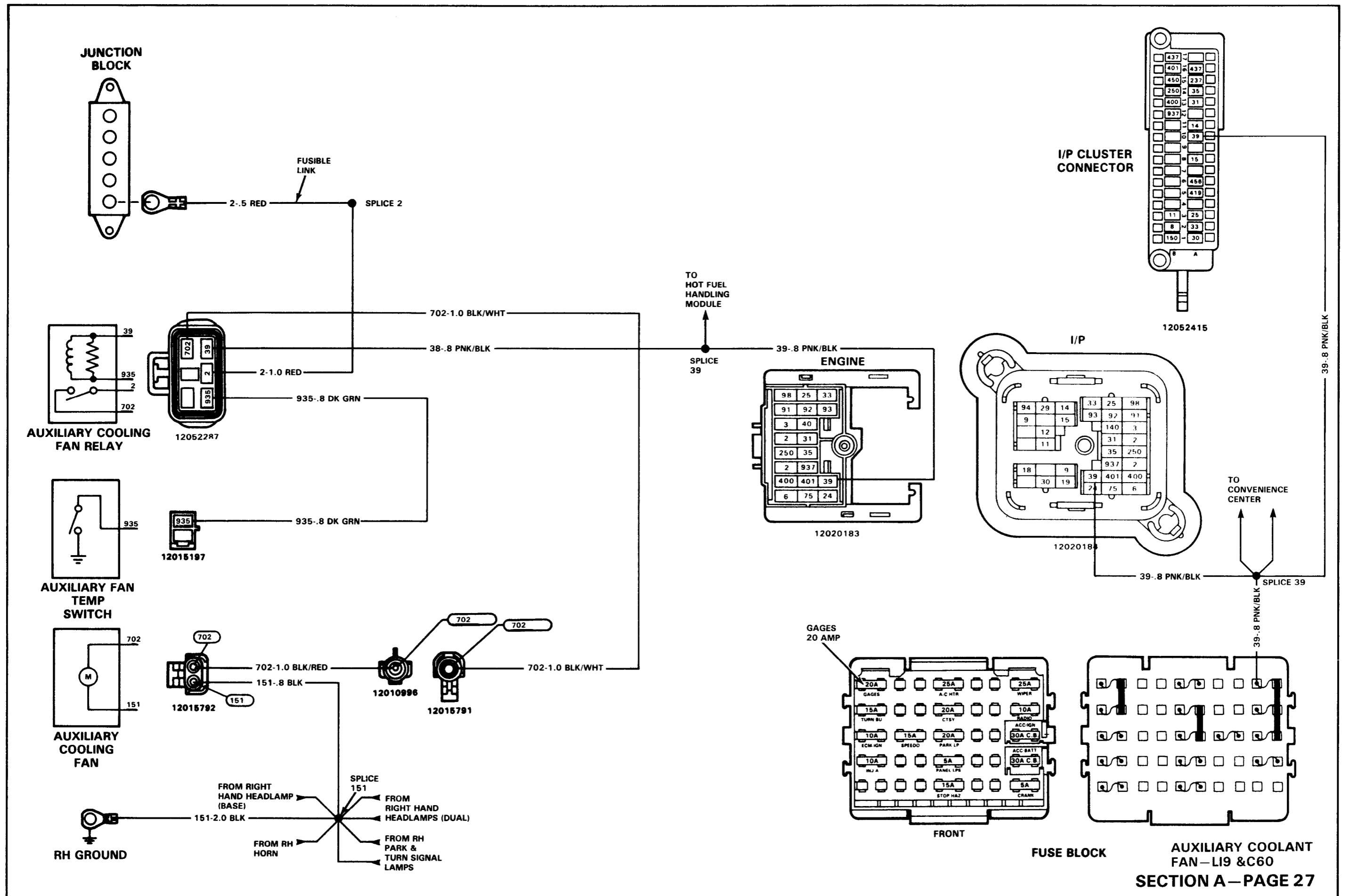

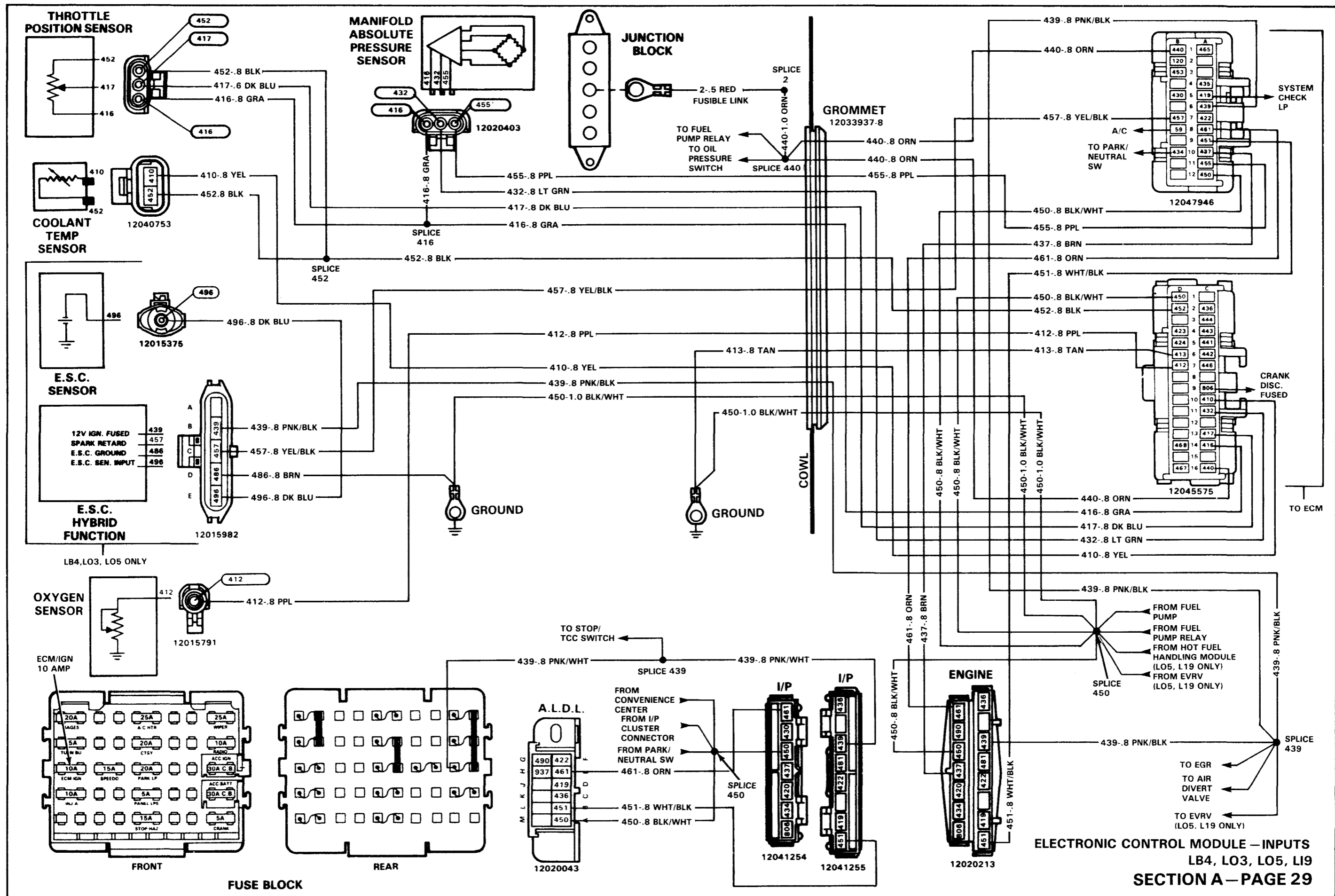

ELECTRONIC CONTROL MODULE – INPUTS
 LB4, LO3, LO5, LI9
SECTION A – PAGE 29

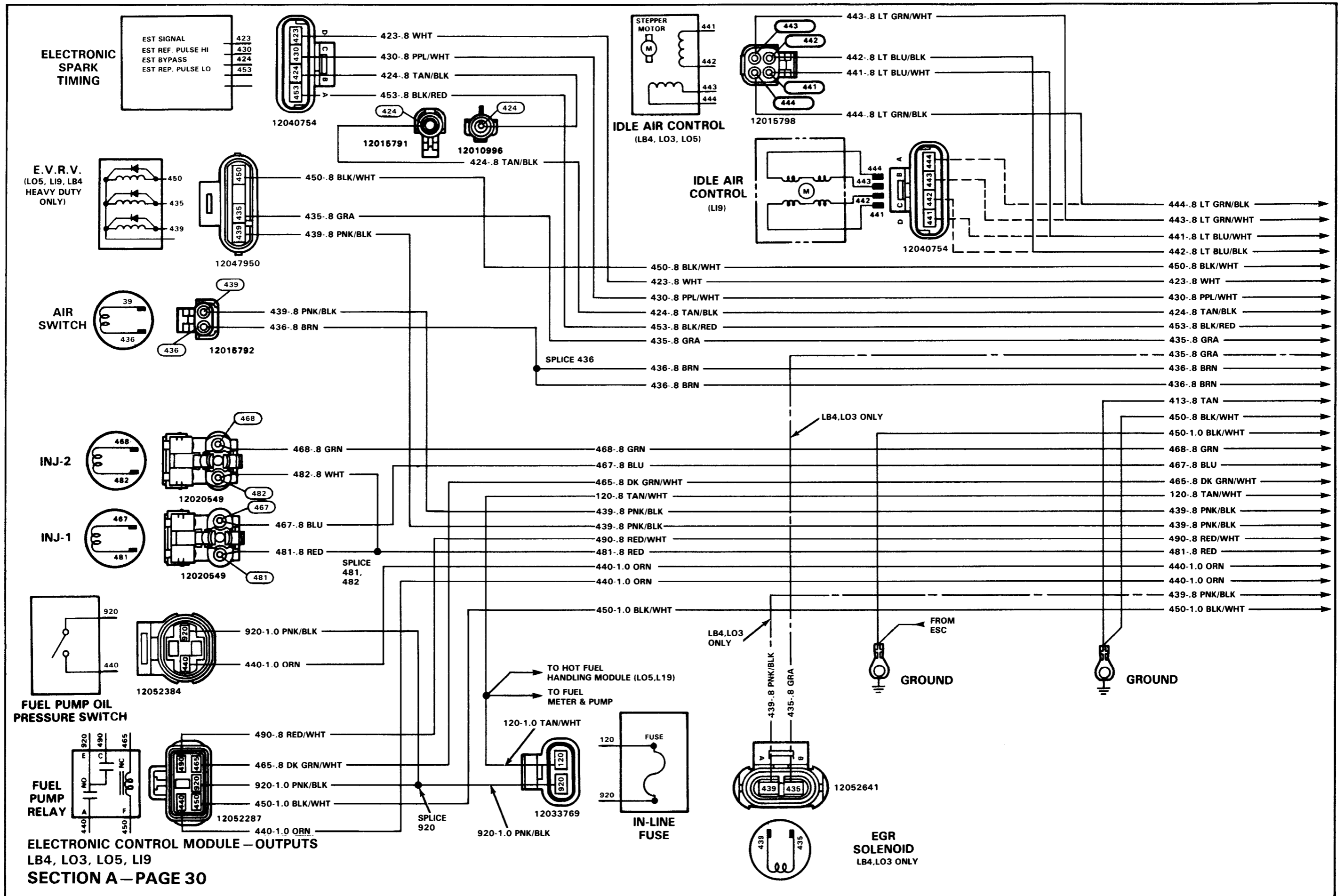

CIRCUIT NO.	WIRE SIZE	COLOR	CAVITY	DESCRIPTION
465	.8	DK GRN/WHT	A1	FUEL PUMP RELAY DRIVE
			A2	NOT USED
			A3	NOT USED
435	.8	GRA	A4	EGR SOLENOID
419	.8	BRN/WHT	A5	SYSTEM CHECK LAMP
439	.8	PNK/BLK	A6	12V IGNITION FUSED
* 422	.8	TAN/BLK	A7	AUTO TRANS KICKDOWN RELAY
456	.8	TAN/BLK	A7	UPSHIFT LAMP
461	.8	ORN	A8	SERIAL DATA
451	.8	WHT/BLK	A9	ASS'Y LINE DIAG. LINK
437	.8	BRN	A10	SPEED SIGNAL
455	.8	PPL	A11	5V RETURN A
450	.8	BLK/WHT	A12	SYSTEM RETURN
440	.8	ORN	B1	12V BATTERY FUSED
120	.8	TAN/WHT	B2	ELEC FUEL PUMP FUSED FEED
453	.8	BLK/RED	B3	DISTRIBUTOR REF LOW
			B4	NOT USED
430	.8	PPL/WHT	B5	DISTRIBUTOR REF HIGH
			B6	NOT USED
457	.8	YEL/RED	B7	SPARK RETARD CONTROL
59	.8	DK GRN	B8	AIR CONDITION
			B9	NOT USED
* 434	.8	ORN/BLK	B10	PARK/NEUTRAL SWITCH
			B11	NOT USED
			B12	NOT USED

* AUTO TRANS ONLY

CIRCUIT NO.	WIRE SIZE	COLOR	CAVITY	DESCRIPTION
			C1	NOT USED
436	.8	BRN	C2	AIR SWITCH SOLENOID
444	.8	LT GRN/BLK	C3	STEPPER COIL B LOW
443	.8	LT GRN/WHT	C4	STEPPER COIL B HIGH
441	.8	LT BLU/WHT	C5	STEPPER COIL A HIGH
442	.8	LT BLU/BLK	C6	STEPPER COIL A LOW
* 446	.8	LT BLU	C7	AUTO TRANS KICKDOWN RELAY
			C8	NOT USED
806	.8	PPL/WHT	C9	CRANK DISCRETE FUSED
410	.8	YEL	C10	COOLANT TEMPERATURE
432	.8	LT GRN	C11	MANIFOLD ABSOLUTE PRESS
			C12	NOT USED
417	.8	DK BLU	C13	THROTTLE POSITION SENSOR
416	.8	GRA	C14	5V SENSOR REFERENCE
			C15	NOT USED
440	.8	ORN	C16	12V BATTERY FUSED
450	.8	BLK/WHT	D1	SYSTEM RETURN
452	.8	BLK	D2	5V RETURN B
			D3	NOT USED
423	.8	WHT	D4	HEI SPARK TIMING
424	.8	TAN/BLK	D5	HEI BYPASS
413	.8	TAN	D6	OXYGEN SENSOR LOW
412	.8	PPL	D7	OXYGEN SENSOR HIGH
			D8	NOT USED
			D9	NOT USED
			D10	NOT USED
			D11	NOT USED
			D12	NOT USED
			D13	NOT USED
468	.8	GRN	D14	INJECTOR B DRIVE
			D15	NOT USED
467	.8	BLU	D16	INJECTOR A DRIVE

* AUTO TRANS ONLY (MD8 ONLY)

CIRCUIT NO.	WIRE SIZE	COLOR	CAVITY	DESCRIPTION
432	.8	LT GRN	A1	MANIFOLD ABSOLUTE PRESS
417	.8	DK BLU	A2	THROTTLE POSITION SWITCH
410	.8	YEL	A3	COOLANT TEMP. SENSOR
			A4	NOT USED
			A5	NOT USED
451	.8	BLK	A6	ASS'Y LINE DIAG. LINK
			A7	NOT USED
121	.8	WHT	A8	ENGINE SPEED SENSOR
437	.8	BRN	A9	SPEED SIGNAL
487	.8	WHT/DK GRN	A10	LAMP DRIVE
			A11	NOT USED
416	.8	GRA	A12	5V REF. VOLT
			B1	NOT USED
			B2	NOT USED
			B3	NOT USED
			B4	NOT USED
			B5	NOT USED
			B6	NOT USED
			B7	NOT USED
			B8	NOT USED
			B9	NOT USED
			B10	NOT USED
			B11	NOT USED
			B12	NOT USED

CIRCUIT NO.	WIRE SIZE	COLOR	CAVITY	DESCRIPTION
452	.8	BLK	C1	SYSTEM RETURN
450	.8	BLK	C2	SYSTEM GROUND
			C3	NOT USED
			C4	NOT USED
* 422	.8	TAN/BLK	C5	TORQUE CONVERTER CLUTCH
901	.8		C6	
			C7	NOT USED
			C8	NOT USED
			C9	NOT USED
435	.8	GRA	C10	EGR DIAGNOSTIC CONNECTOR
902	.8	LT BLU	C11	EGR SOLENOID
538	.8	DK GRN	C12	EPR SOLENOID
			C13	NOT USED
439	.8	PNK/BLK	C14	12V IGNITION FUSED
			C15	NOT USED
440	.8	ORN	C16	12V BATTERY FUSED
			D1	NOT USED
			D2	NOT USED
			D3	NOT USED
			D4	NOT USED
			D5	NOT USED
			D6	NOT USED
			D7	NOT USED
			D8	NOT USED
			D9	NOT USED
			D10	NOT USED
			D11	NOT USED
			D12	NOT USED
			D13	NOT USED
			D14	NOT USED
			D15	NOT USED
			D16	NOT USED

* AUTO TRANS ONLY

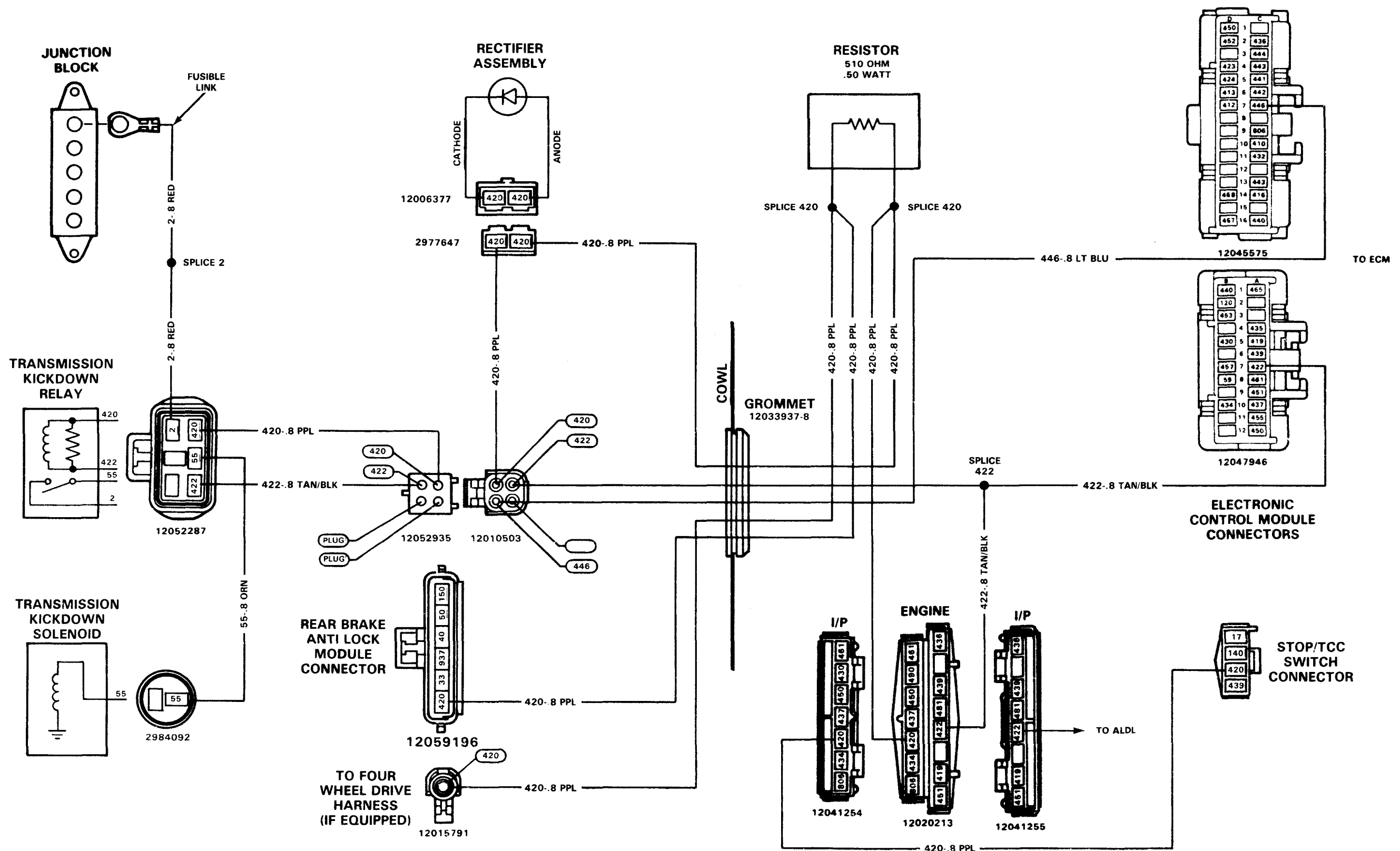

AUTOMATIC TRANSMISSION
KICKDOWN SOLENOID (GAS ENG. ONLY)
SECTION A — PAGE 38

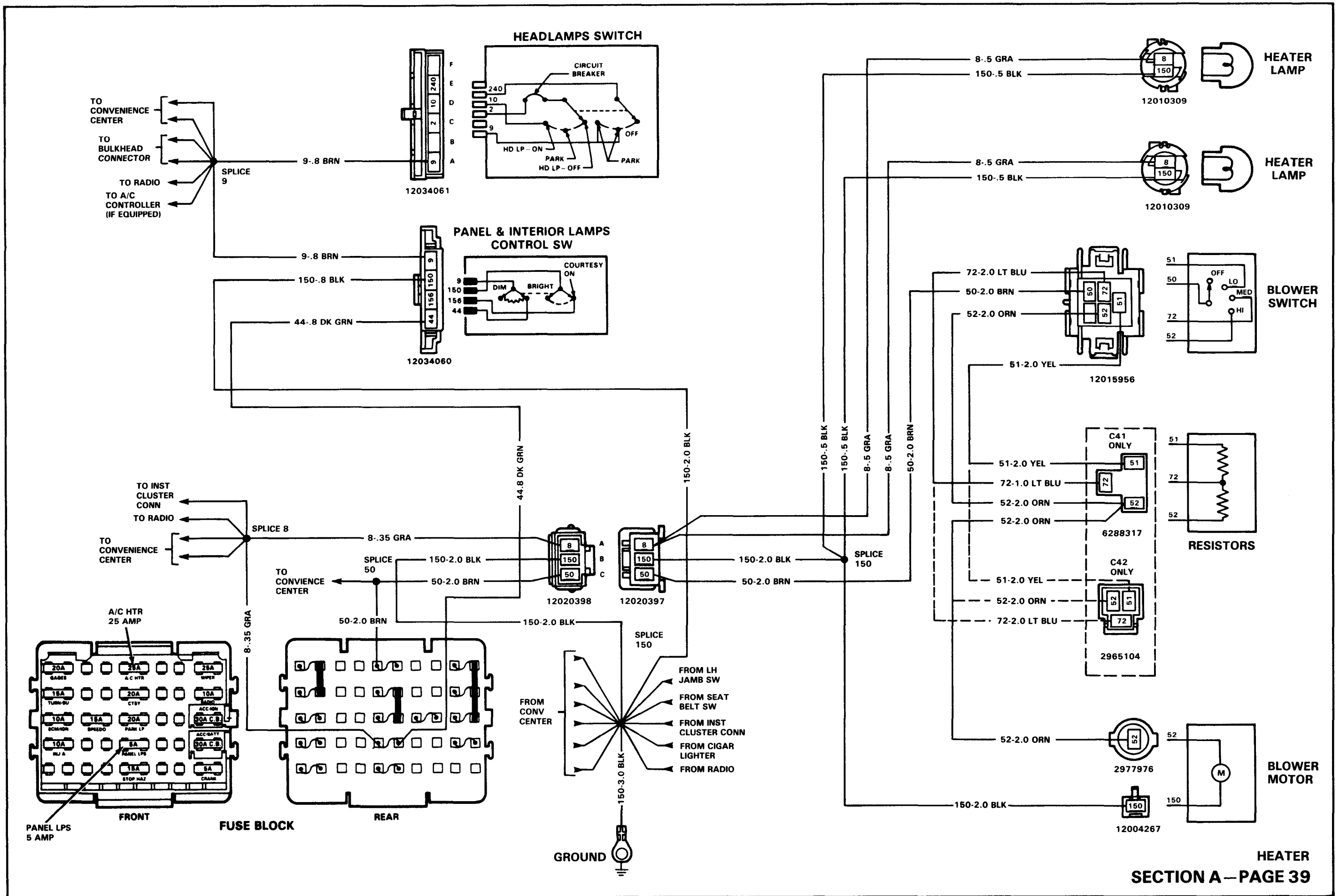

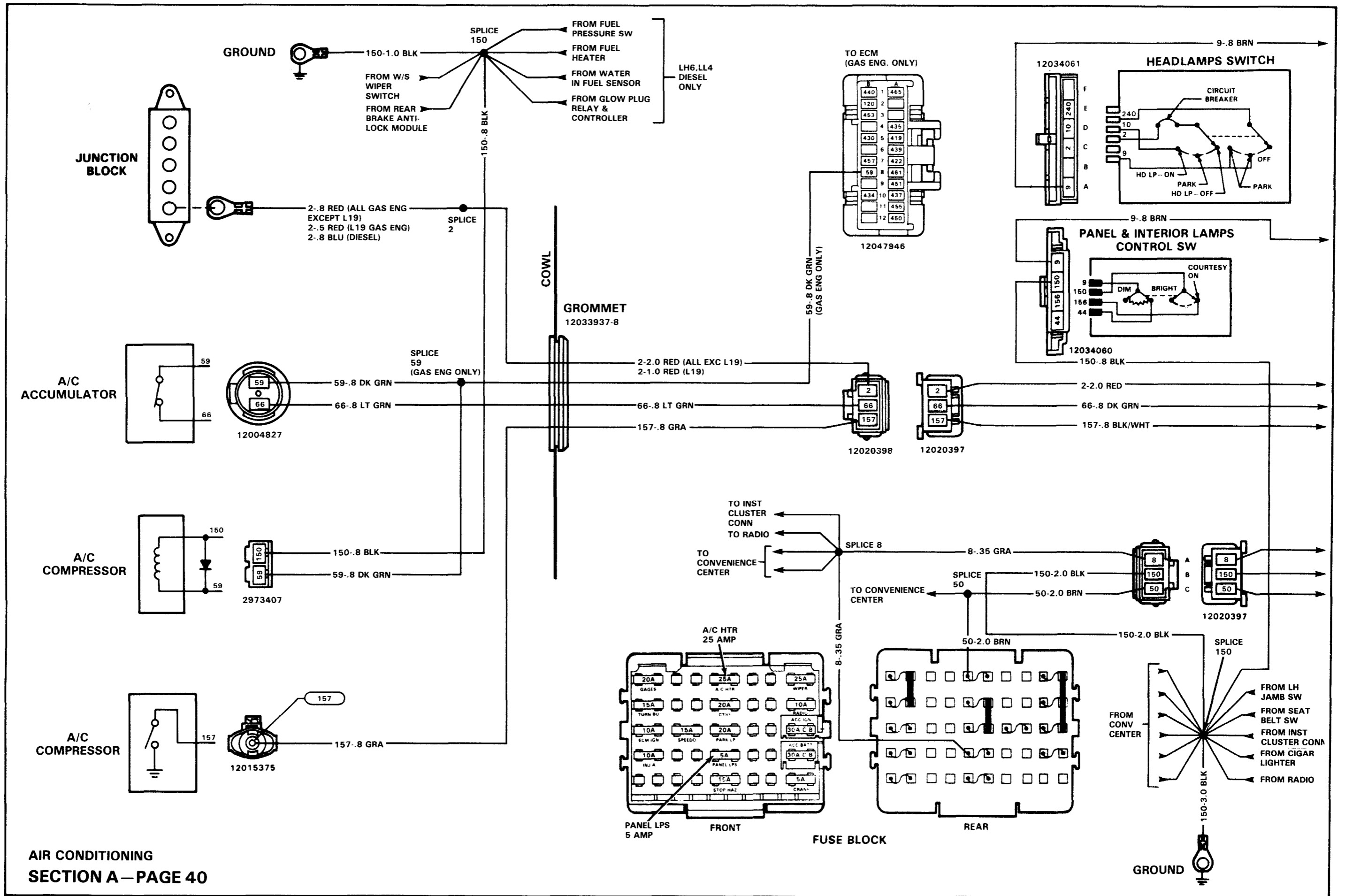

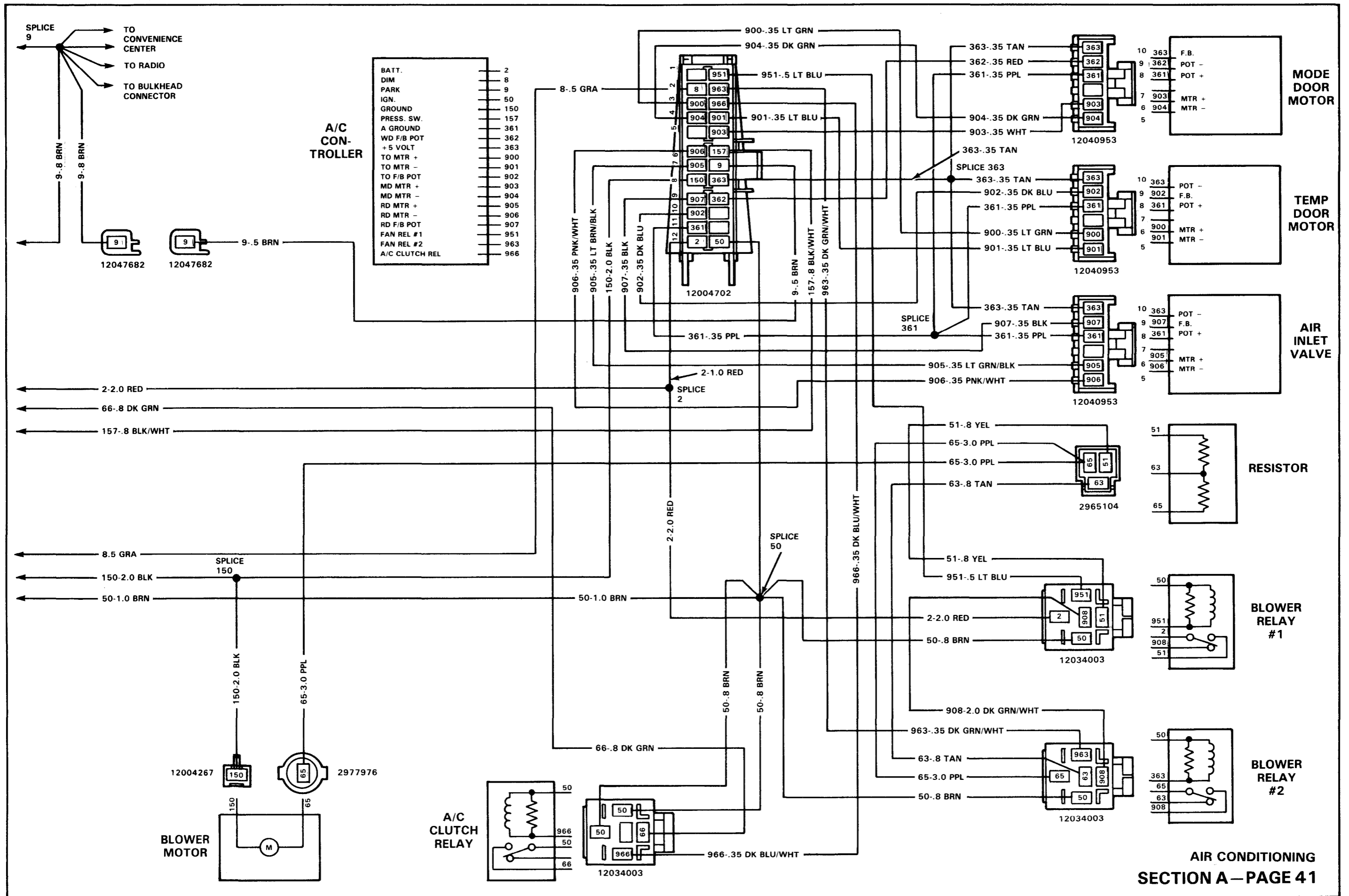

REAR WHEEL ANTI-LOCK MODULE CONNECTOR

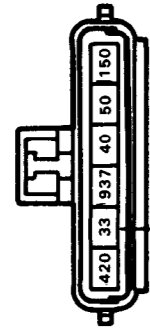

12059196

33-.8 TAN/WHT

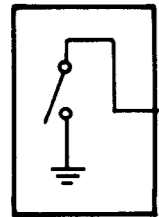

BRAKE PRESSURE WARNING SWITCH

33



12004635

33-.8 TAN/WHT

SPLICE 33

33-.8 TAN/WHT

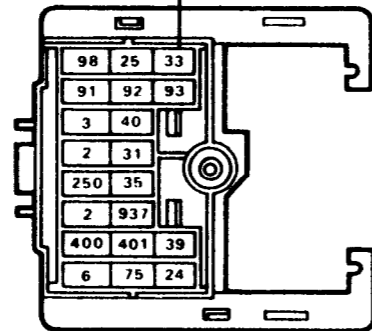

ENGINE

12020183

I/P

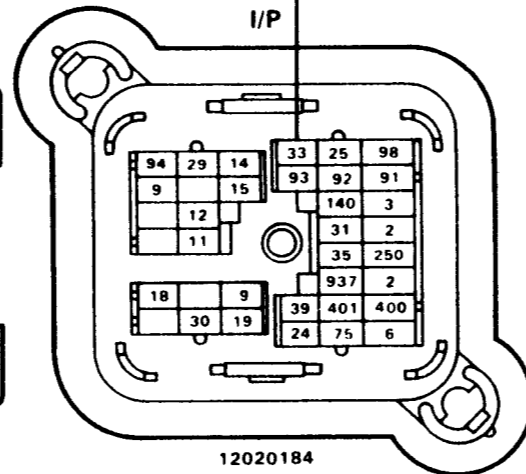

12020184

IN-LINE DIODE (POWER BRAKES ONLY)

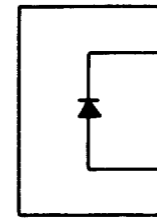

POWER BRAKES ONLY

33-.5 TAN/WHT

33

33-.5 TAN/WHT

SPLICE 33 MANUAL BRAKES ONLY

33-.5 TAN/WHT

33-.5 TAN/WHT

33-.5 TAN/WHT

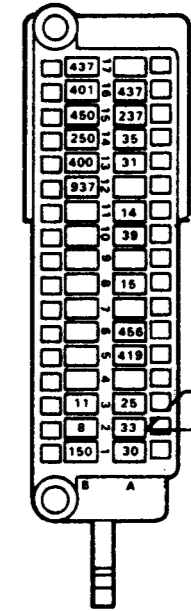

I/P CLUSTER CONNECTOR

12052415

PARK BRAKE SWITCH CLOSED WITH PARK BRAKE ON

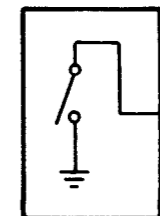

33

12004267

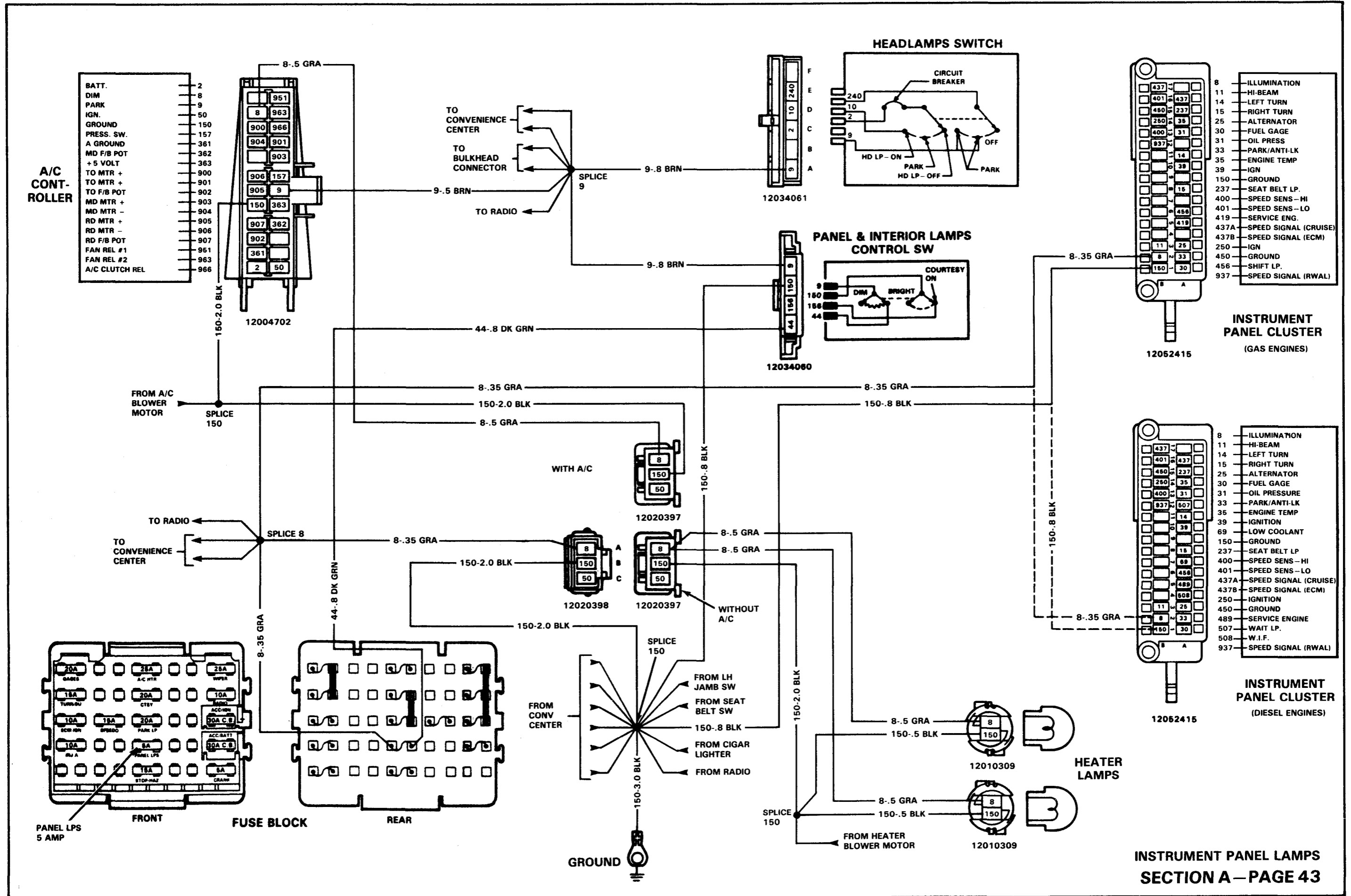

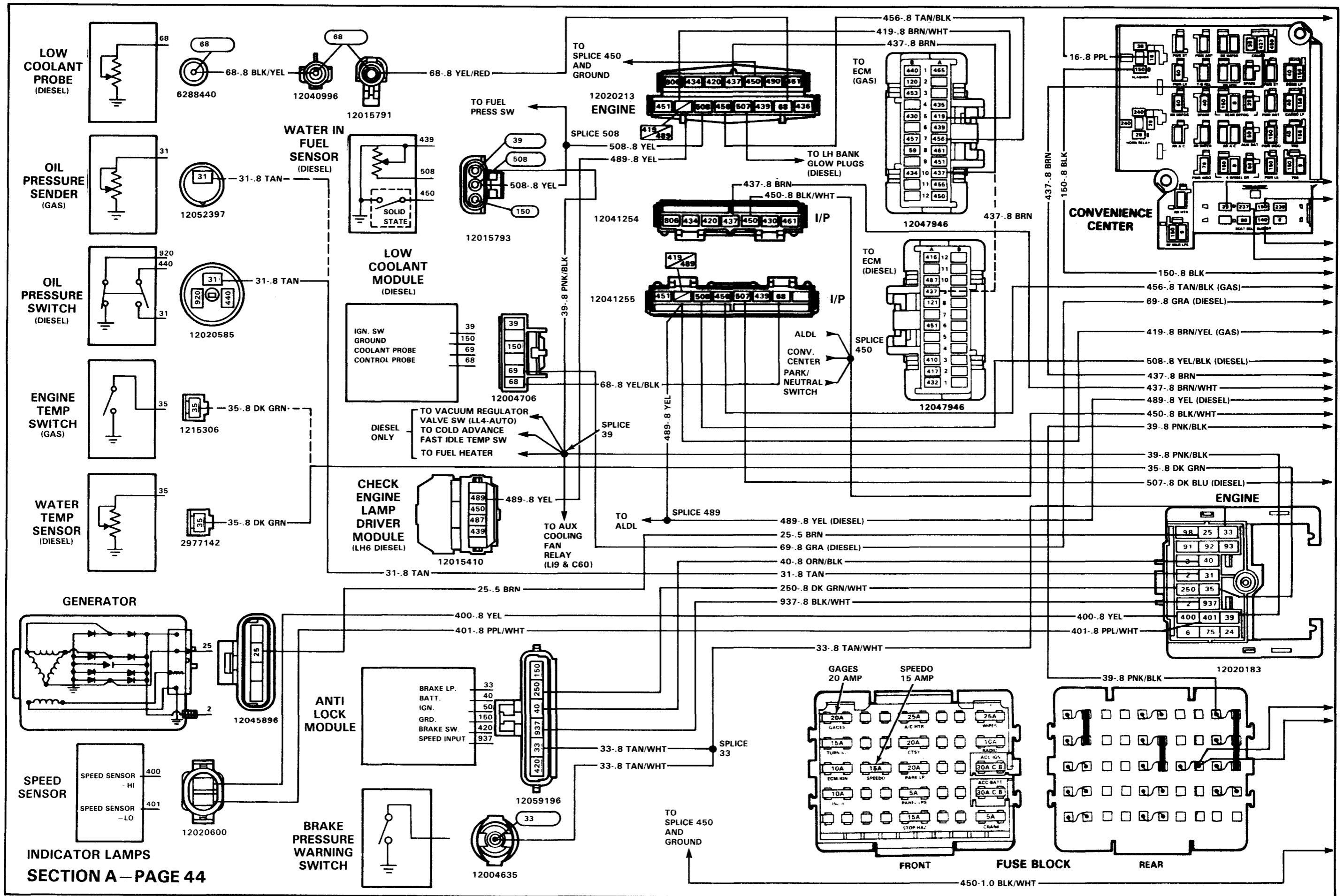

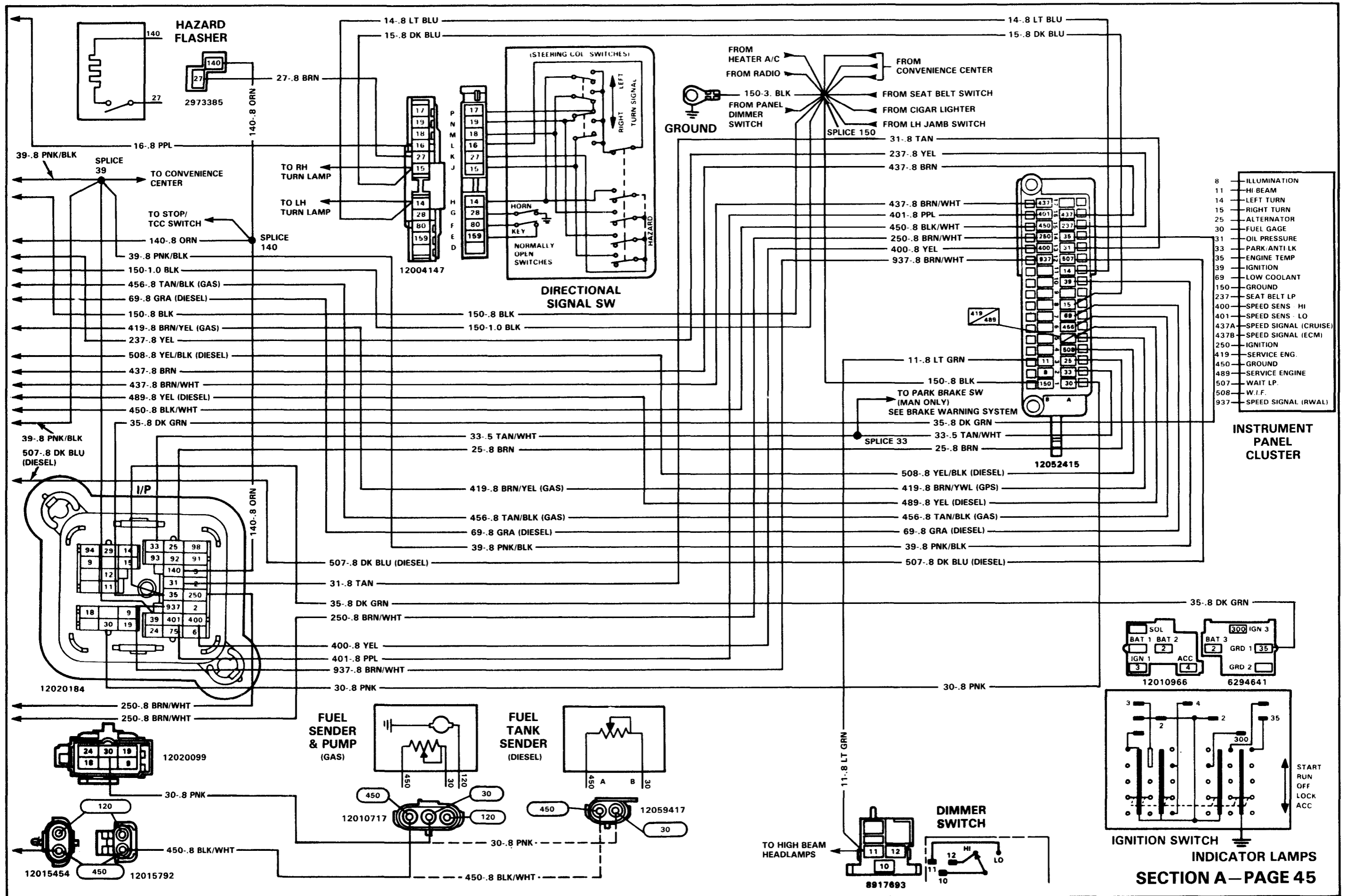

- 8 ILLUMINATION
- 11 HI BEAM
- 14 LEFT TURN
- 15 RIGHT TURN
- 25 ALTERNATOR
- 30 FUEL GAGE
- 31 OIL PRESSURE
- 33 PARK/ANTI LK
- 35 ENGINE TEMP
- 39 IGNITION
- 69 LOW COOLANT
- 150 GROUND
- 237 SEAT BELT LP
- 400 SPEED SENS HI
- 401 SPEED SENS LO
- 437A SPEED SIGNAL (CRUISE)
- 437B SPEED SIGNAL (ECM)
- 250 IGNITION
- 419 SERVICE ENG.
- 450 GROUND
- 489 SERVICE ENGINE
- 507 WAIT LP
- 508 W.I.F.
- 937 SPEED SIGNAL (RWAL)

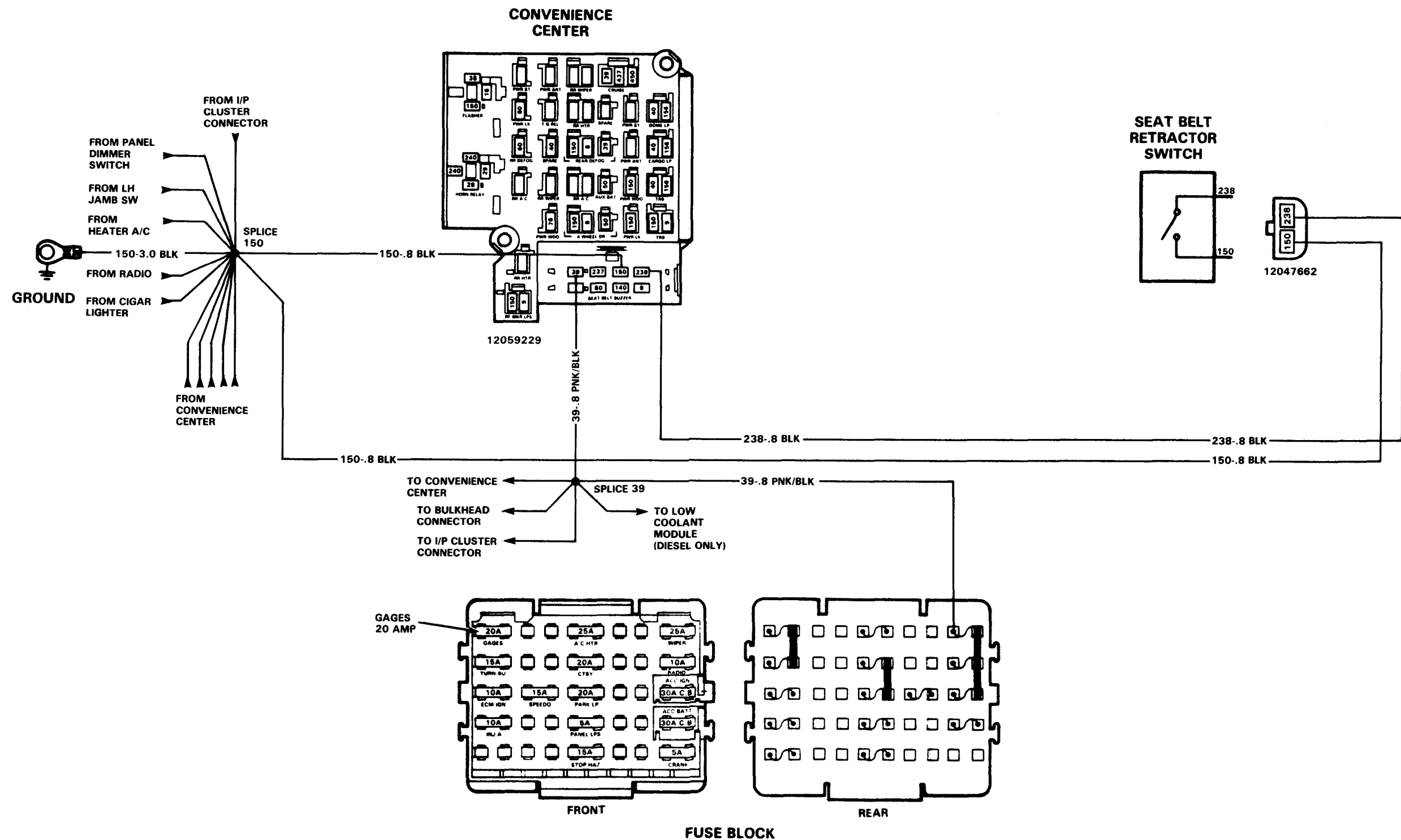

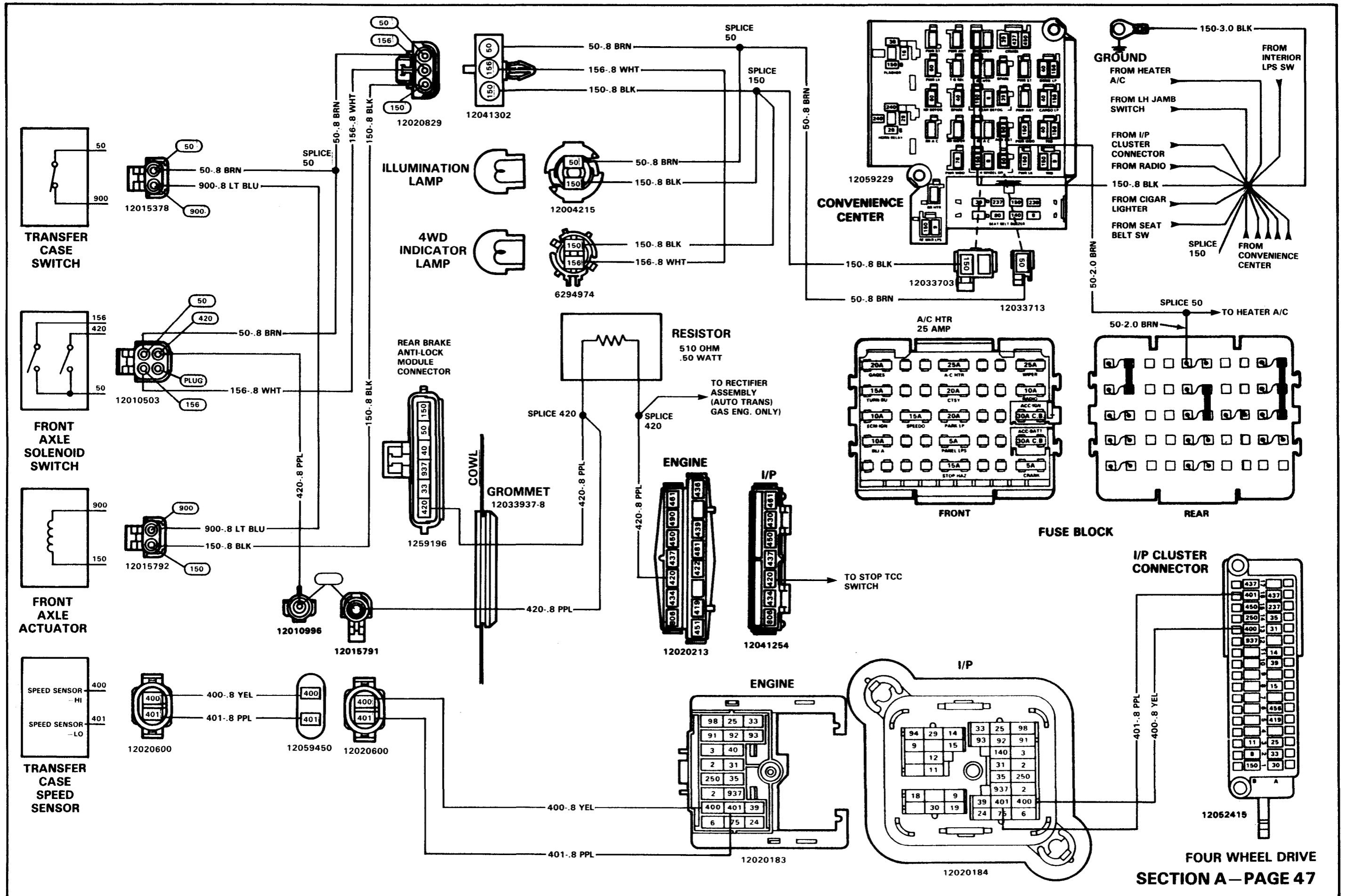

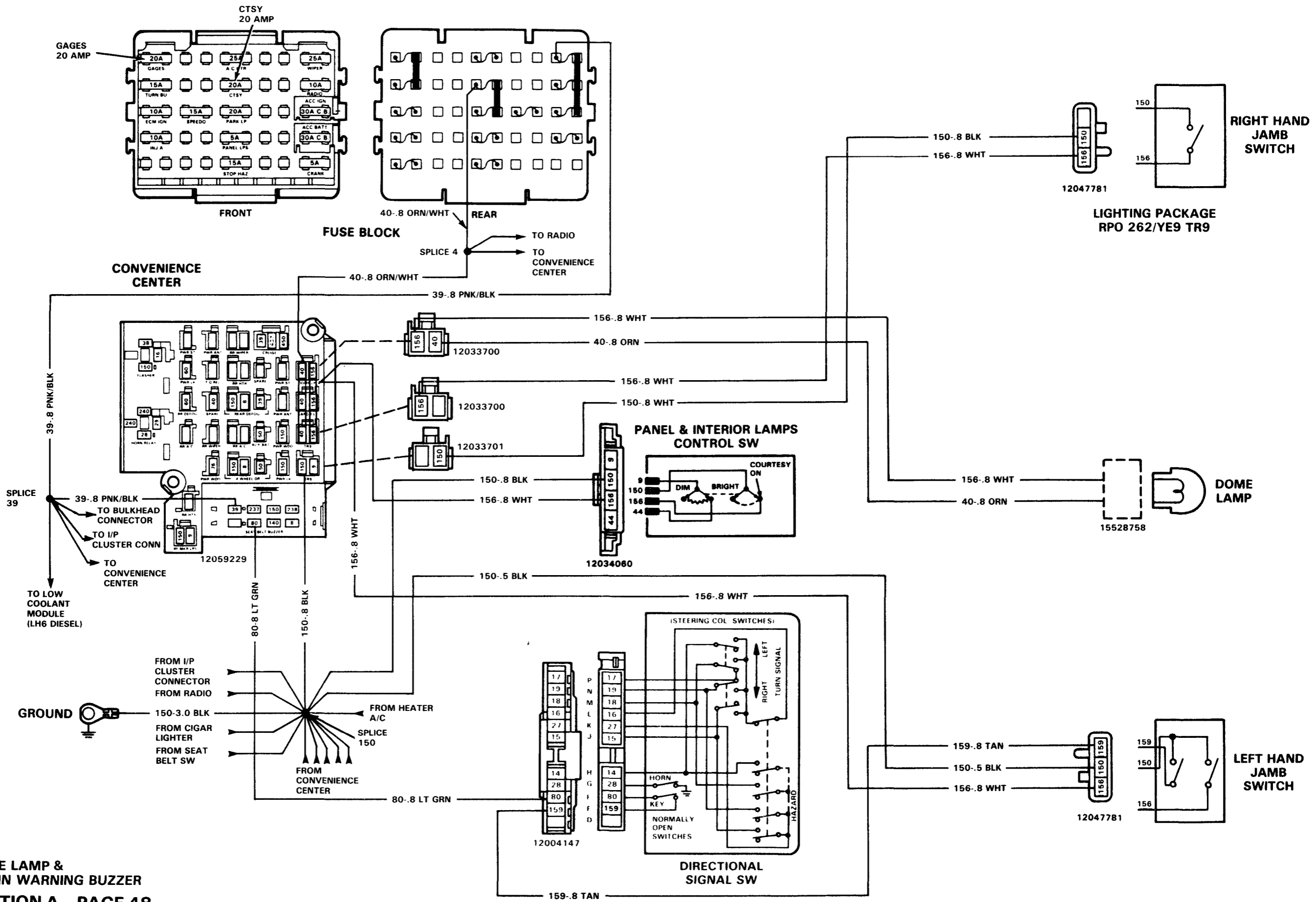

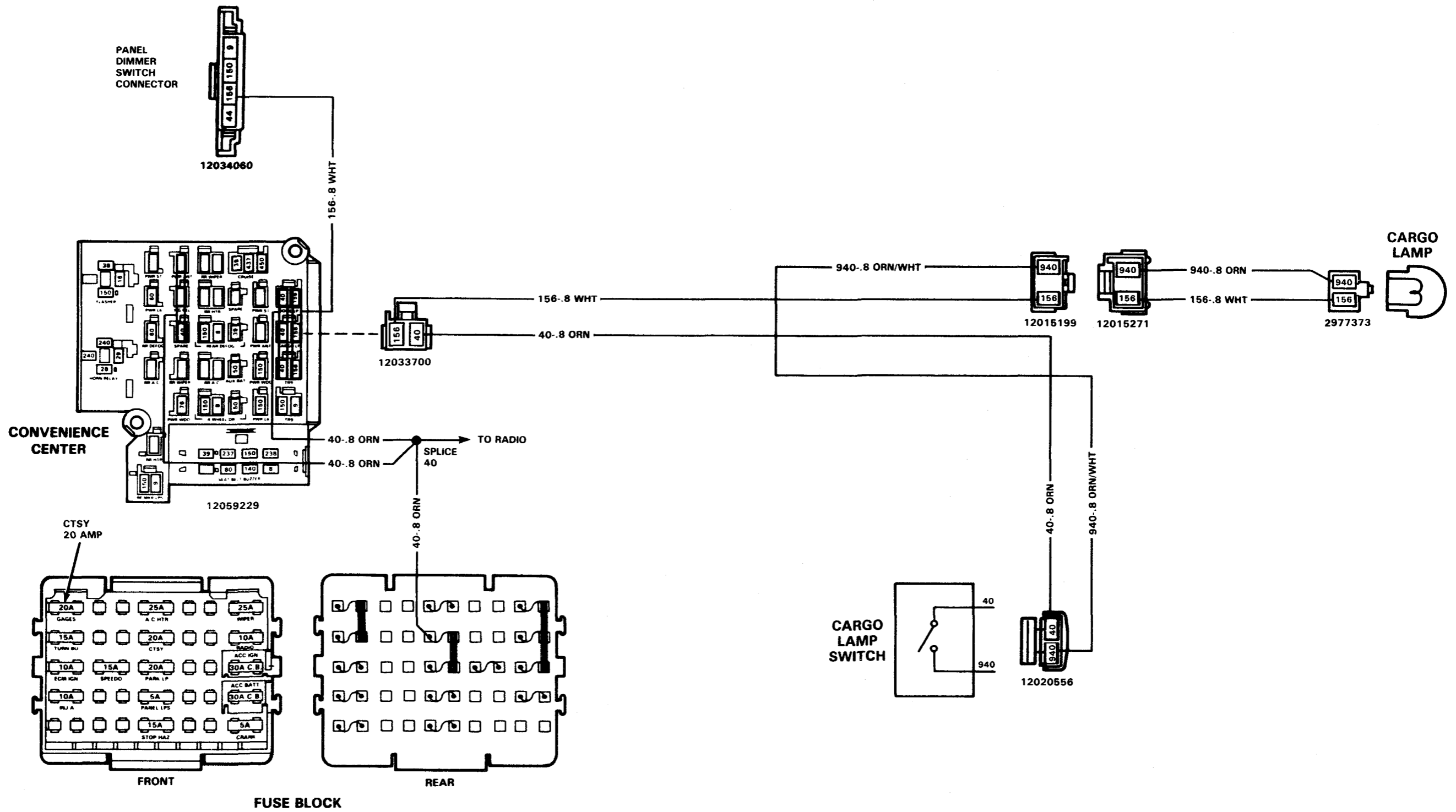

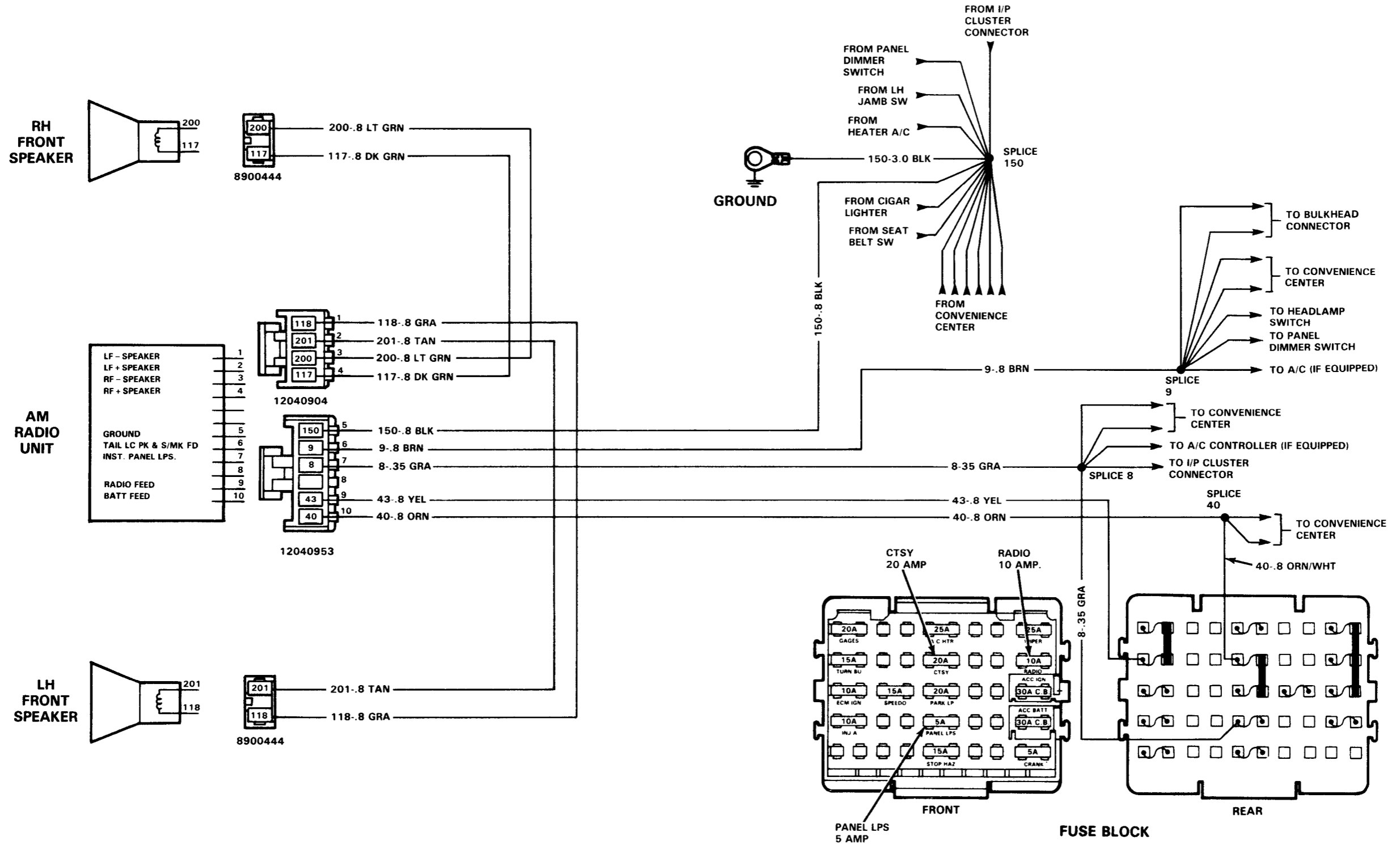

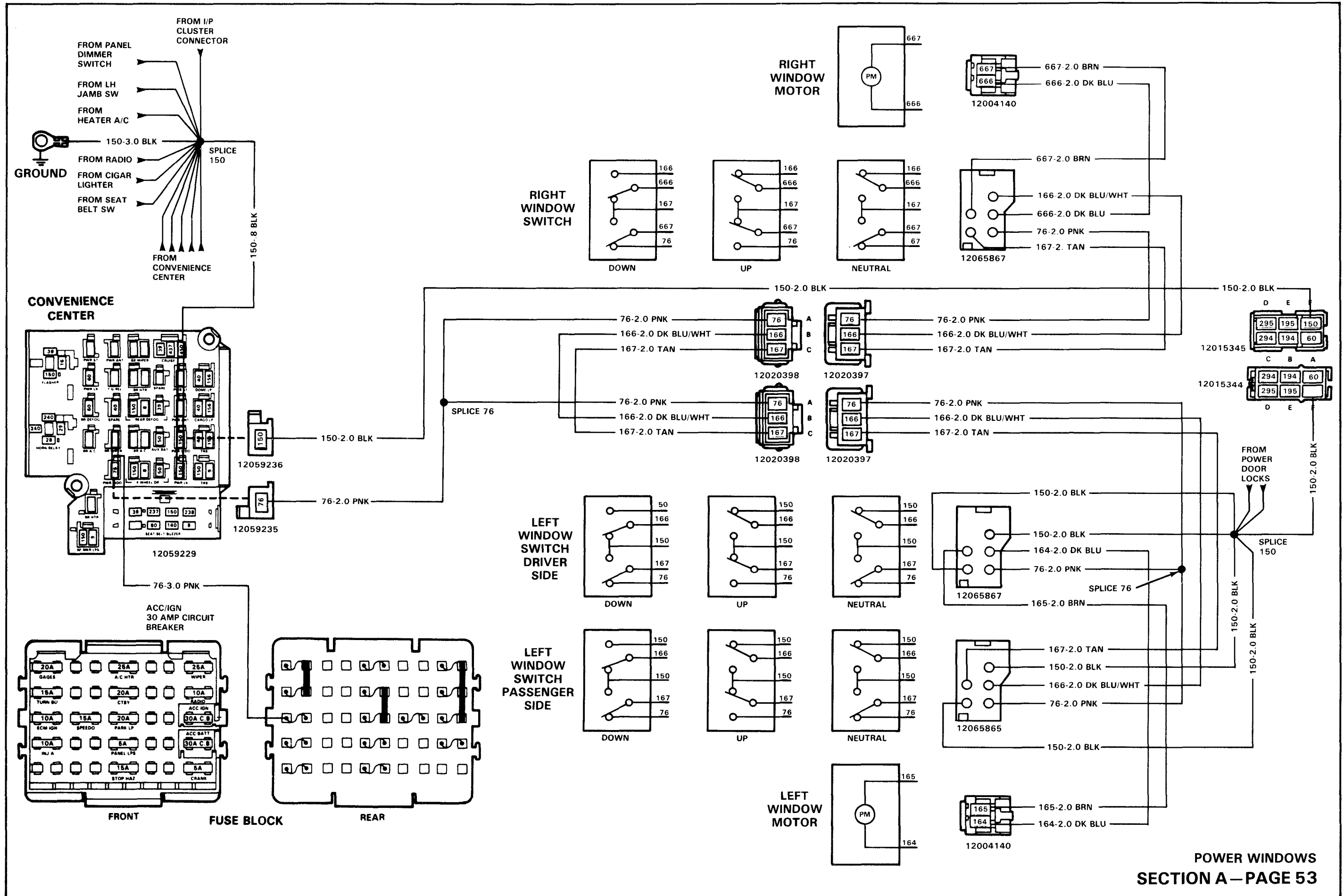

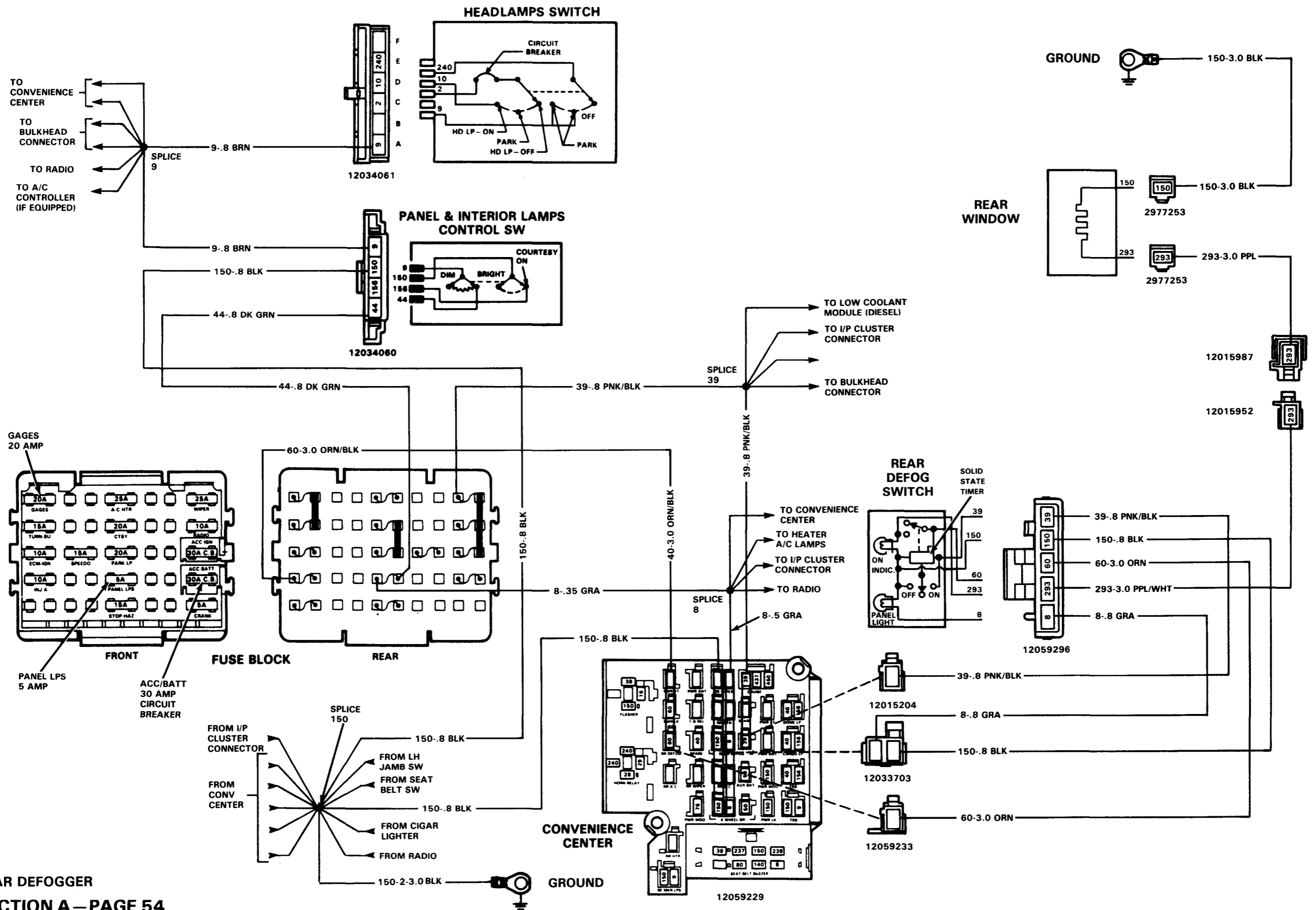

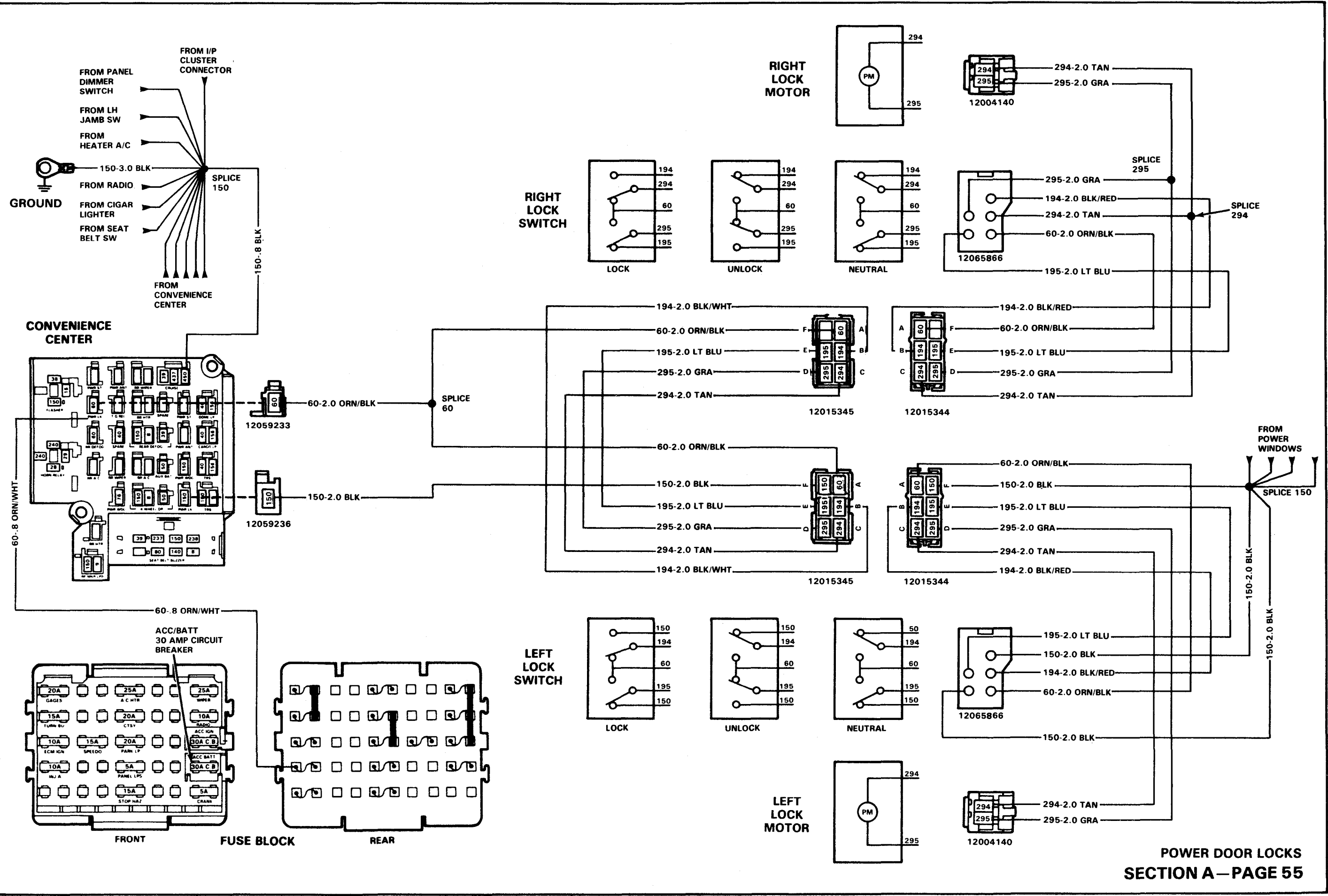

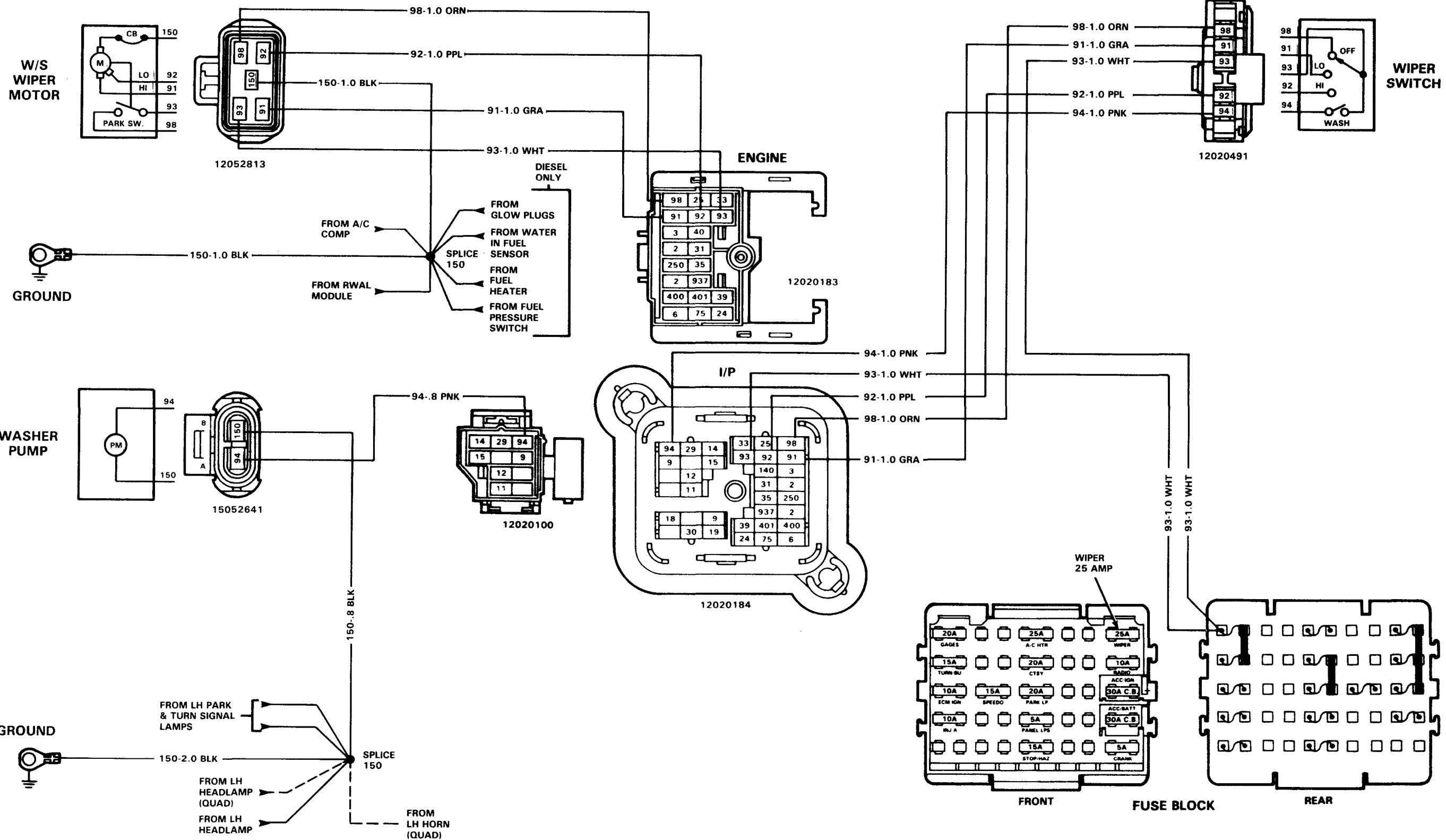

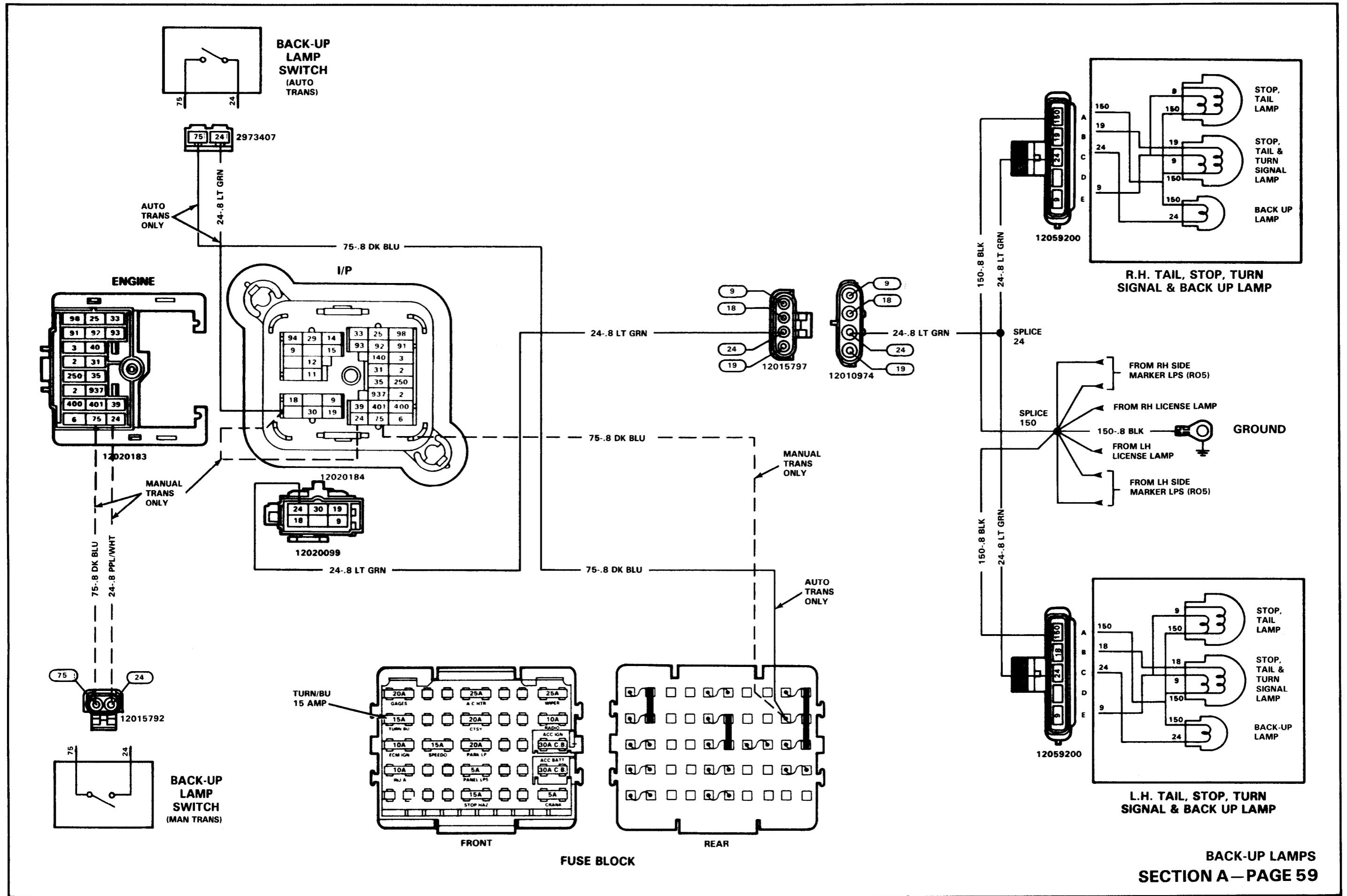

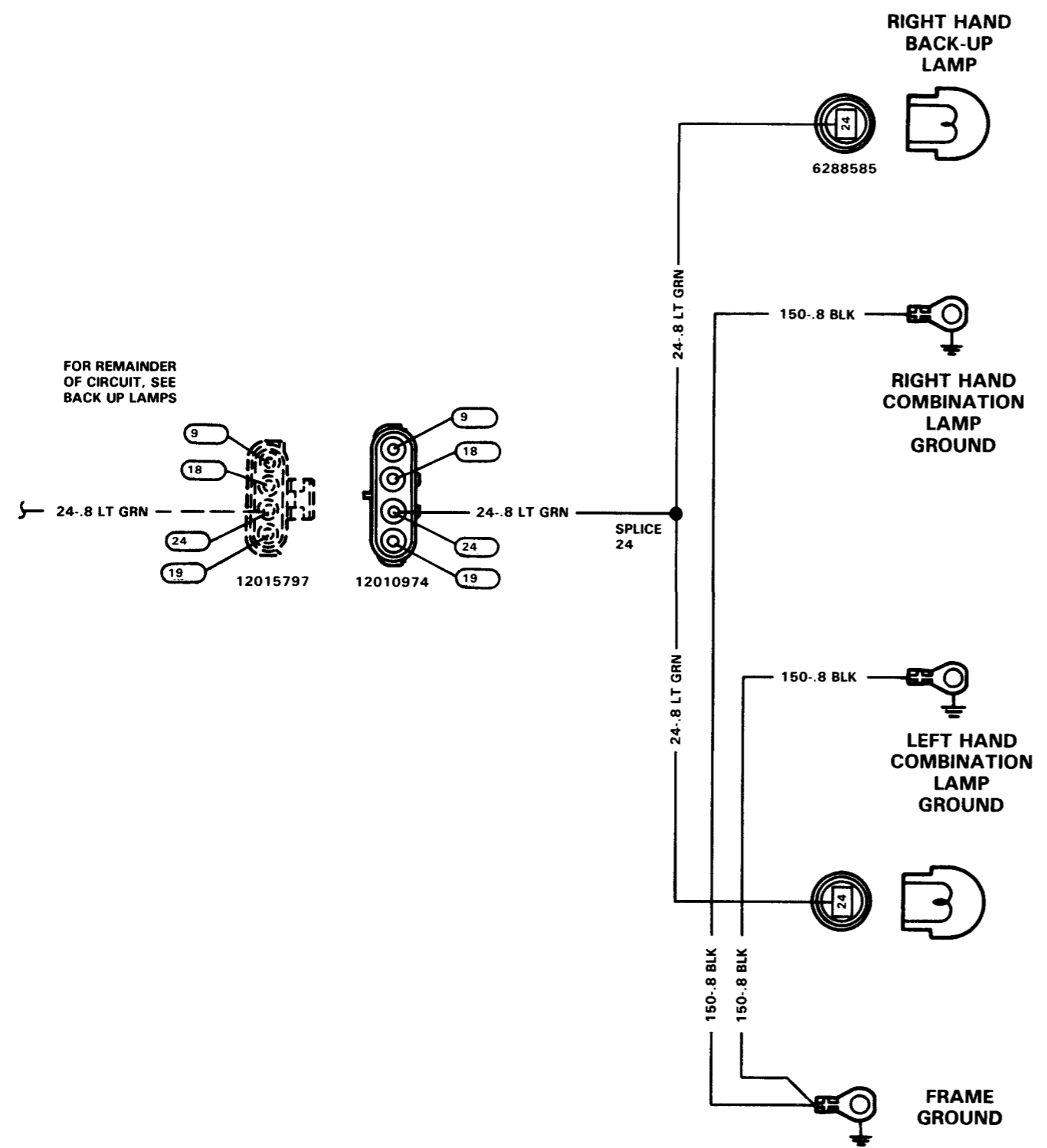

BACK UP LAMPS CAB-CHASSIS

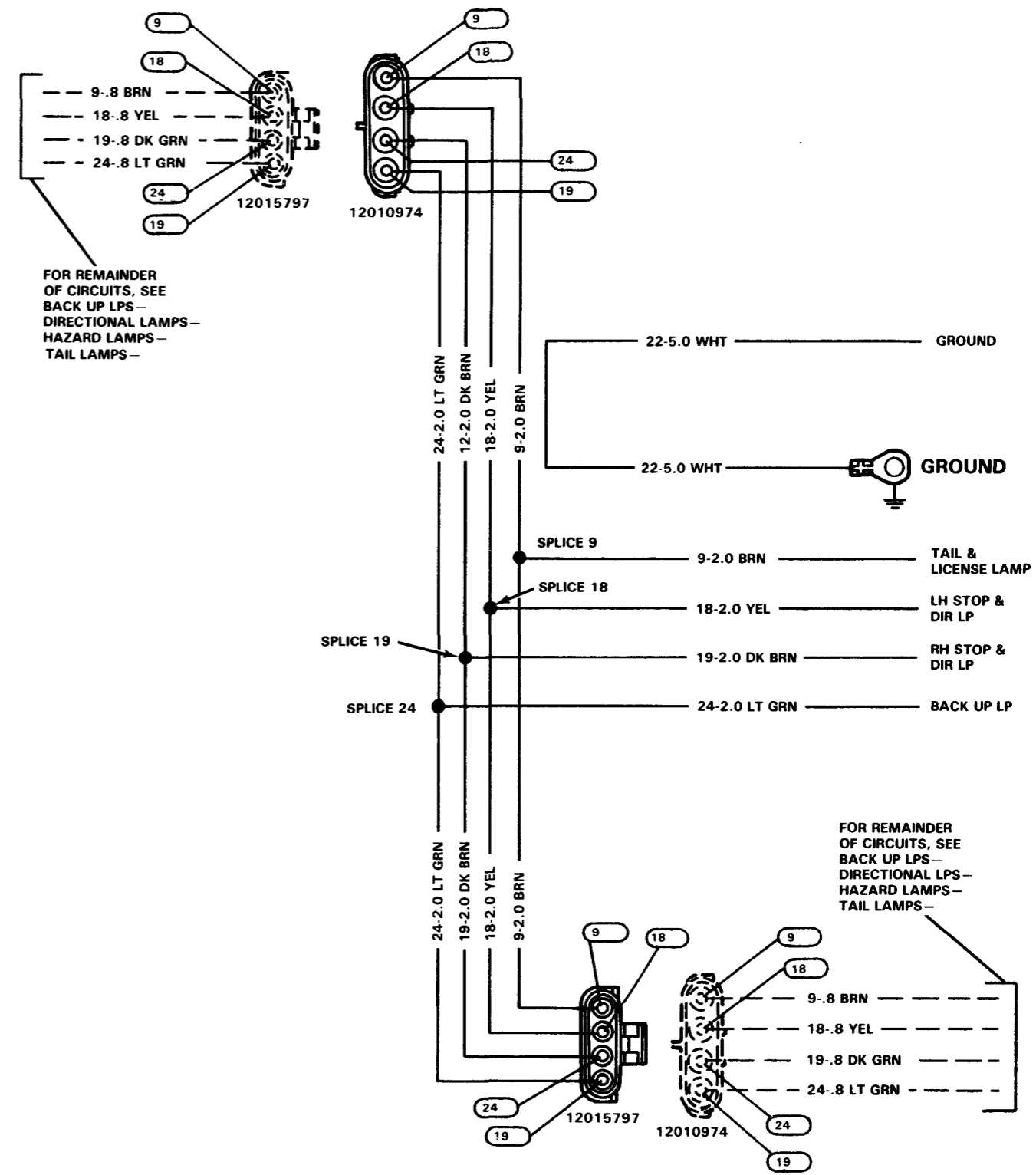

TRAILER-CAMPER WIRING
RPO UY7

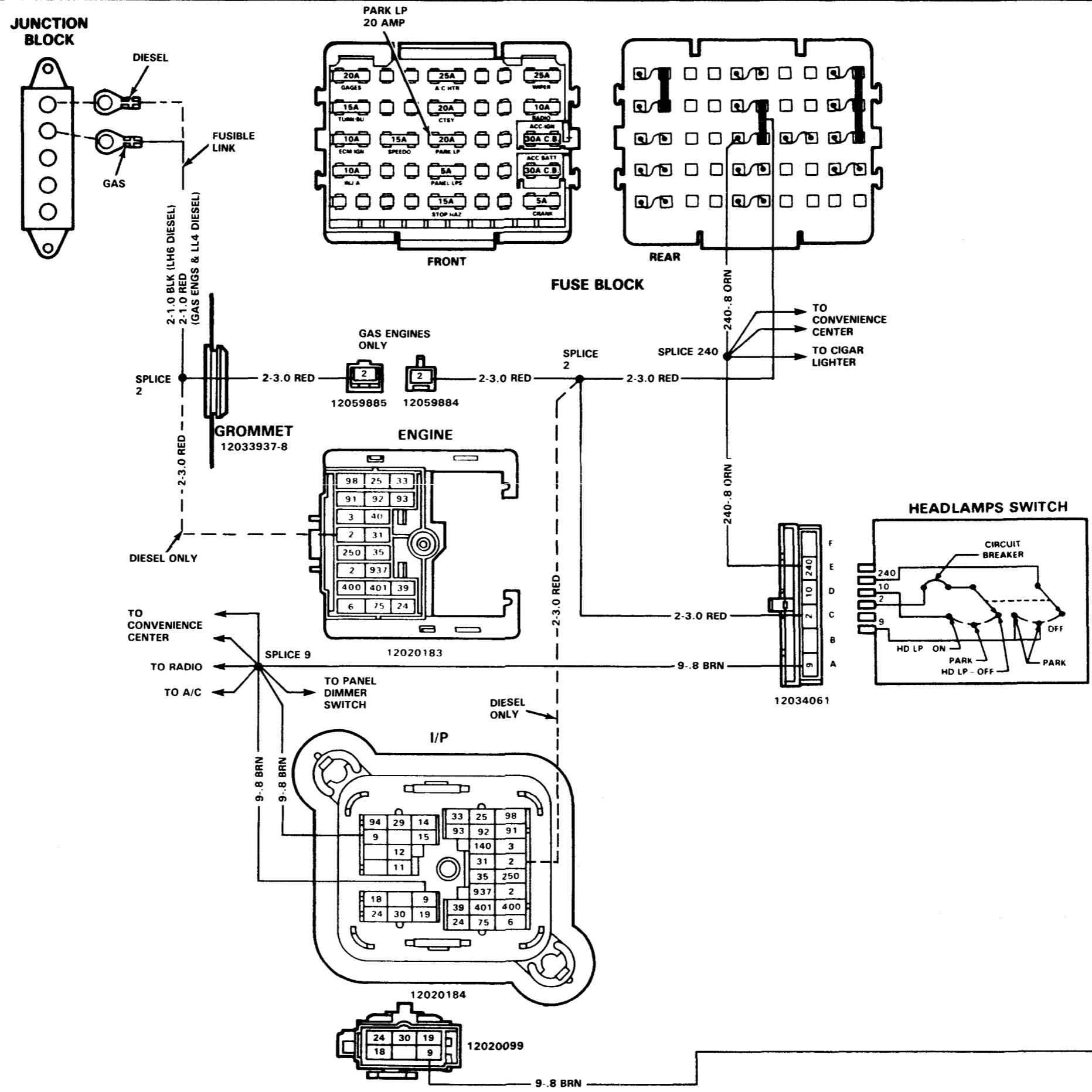

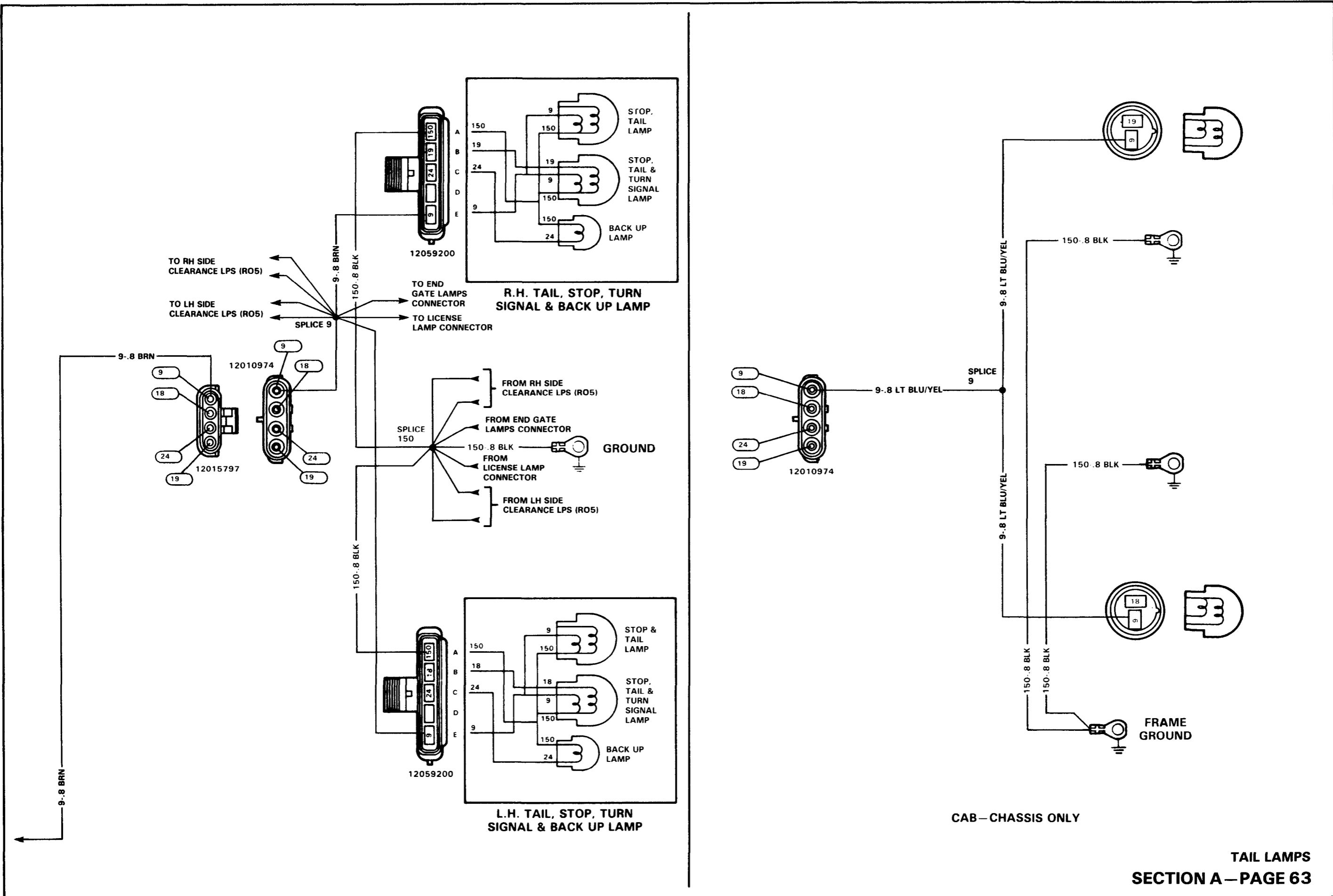

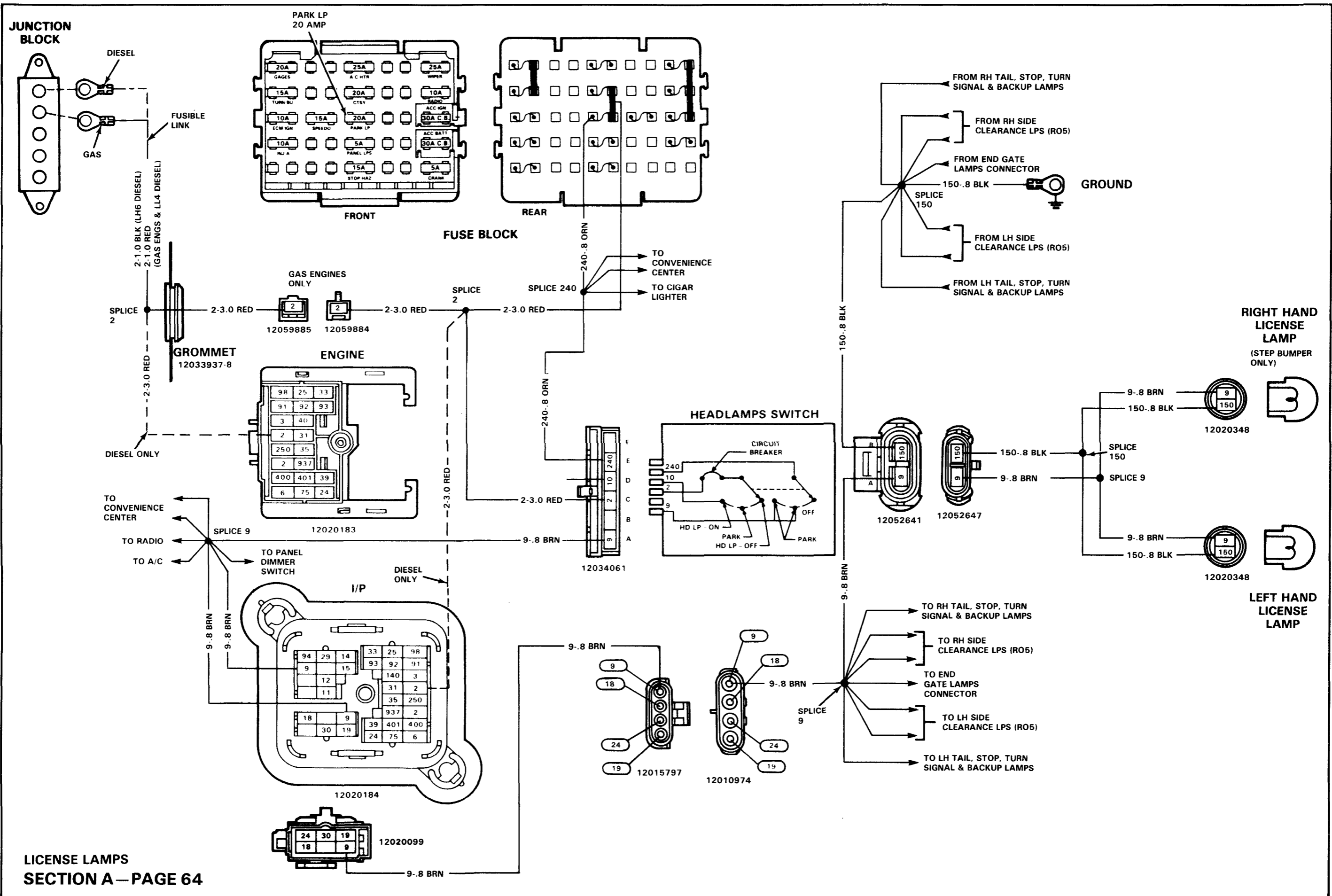

1988 G VAN

SECTION B

<u>PAGE</u>	<u>DESCRIPTION</u>	<u>PAGE</u>	<u>DESCRIPTION</u>
2	POWER DISTRIBUTION (GASOLINE)	42	TRANSMISSION CONVERTER CLUTCH DETENT SOLENOID
3	POWER DISTRIBUTION (DIESEL)	43	AUTO TRANSMISSION KICKDOWN SOLENOID (M40)
4	FUSE BLOCK DETAIL	44	AIR CONDITIONING (C60)
5	HEAD LAMPS & PARKING LAMPS	45	REAR AIR CONDITIONING (C69)
6	MARKER LAMPS	46	HEATER
8	HAZARD LAMPS	47	AUXILIARY HEATER (C36)
10	DIRECTIONAL LAMPS	48	BRAKE WARNING SYSTEM
12	HORN(S)	49	BRAKE WARNING SYSTEM (UJ1)
13	START (6 CYL.) LB4, (8 CYL.) L03, L05, L19	50	INSTRUMENT PANEL LAMPS (TELLTALE VERSION)
14	START (8 CYL.) LT9 & NB2	51	INSTRUMENT PANEL LAMPS (GAGE VERSION)
15	START (8 CYL.) LT9 & NA5	52	INSTRUMENT PANEL GAGES (TELLTALE VERSION)
17	START (DIESEL) LL4, LH6	54	INSTRUMENT PANEL GAGES (GAGE VERSION)
18	IGNITION (6 CYL.) LB4	56	INDICATOR LAMPS (TELLTALE VERSION)
20	IGNITION (8 CYL.) L03, L05, L19	58	INDICATOR LAMPS (GAGE VERSION)
22	IGNITION (8 CYL.) LT9 & NB2	60	DOME LAMPS
23	IGNITION (8 CYL.) L19 & NA5	61	AUXILIARY LIGHTING (TR9) STEPWELL & READING LAMP
24	THROTTLE BODY INJECTION	62	RADIO EQUIPMENT (STEREO) (UN3, UN8, UM6)
25	HOT FUEL HANDLING	63	RADIO EQUIPMENT (U63)
26	GLOW PLUGS (DIESEL)	64	SEAT BELT WARNING BUZZER
28	ENGINE CONTROLS (DIESEL)	65	POWER WINDOWS (A31)
30	FUEL CONTROL & IDLE AIR CONTROL (6 CYL.) LB4, (8 CYL.) L03, L05, L19	66	POWER DOOR LOCKS (AU3)
31	EMISSION CONTROLS (8 CYL.) LT9 & NA5	67	POWER DOOR LOCKS WITH DELAY MODULE (U3)
32	ELECTRONIC CONTROL MODULE (ECM)—INPUTS (6 & 8 CYL.)	68	WIPER/WASHER
34	ELECTRONIC CONTROL MODULE (ECM)—OUTPUTS (6 & 8 CYL.)	69	PULSE WIPER/WASHER (CD4)
36	ECM CHART (6 & 8 CYL.)	71	CRUISE CONTROL (K34)
37	ELECTRONIC CONTROL MODULE (ECM)—INPUTS (DIESEL)	72	BACK-UP LAMPS
38	ELECTRONIC CONTROL MODULE (ECM)—OUTPUTS (DIESEL)	74	TAIL LAMPS
40	ECM CHART (DIESEL)	76	LICENSE LAMP(S)
41	AUXILIARY COOLING FAN	78	TRAILER WIRING

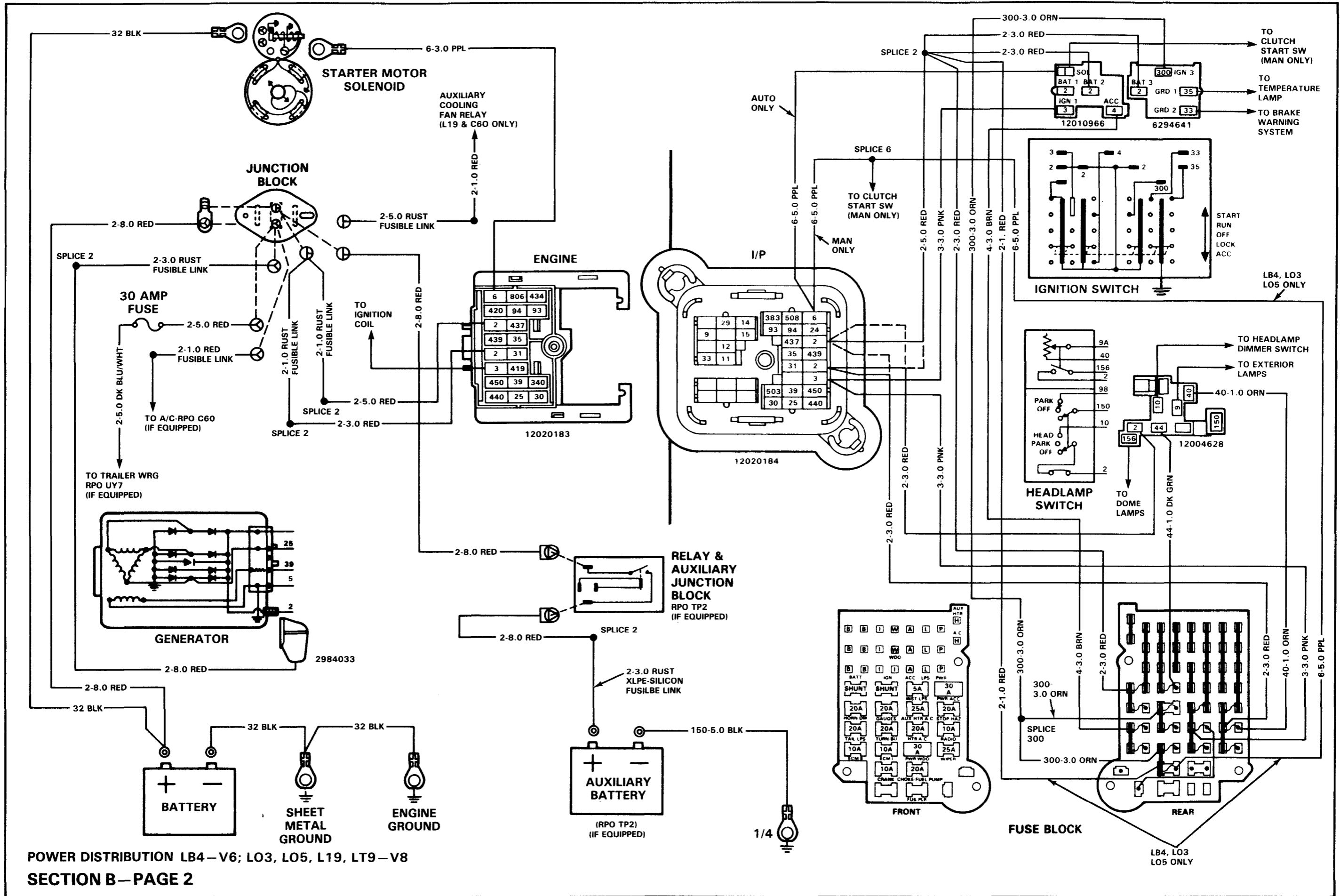

POWER DISTRIBUTION LB4-V6; LO3, LO5, L19, LT9-V8
SECTION B-PAGE 2

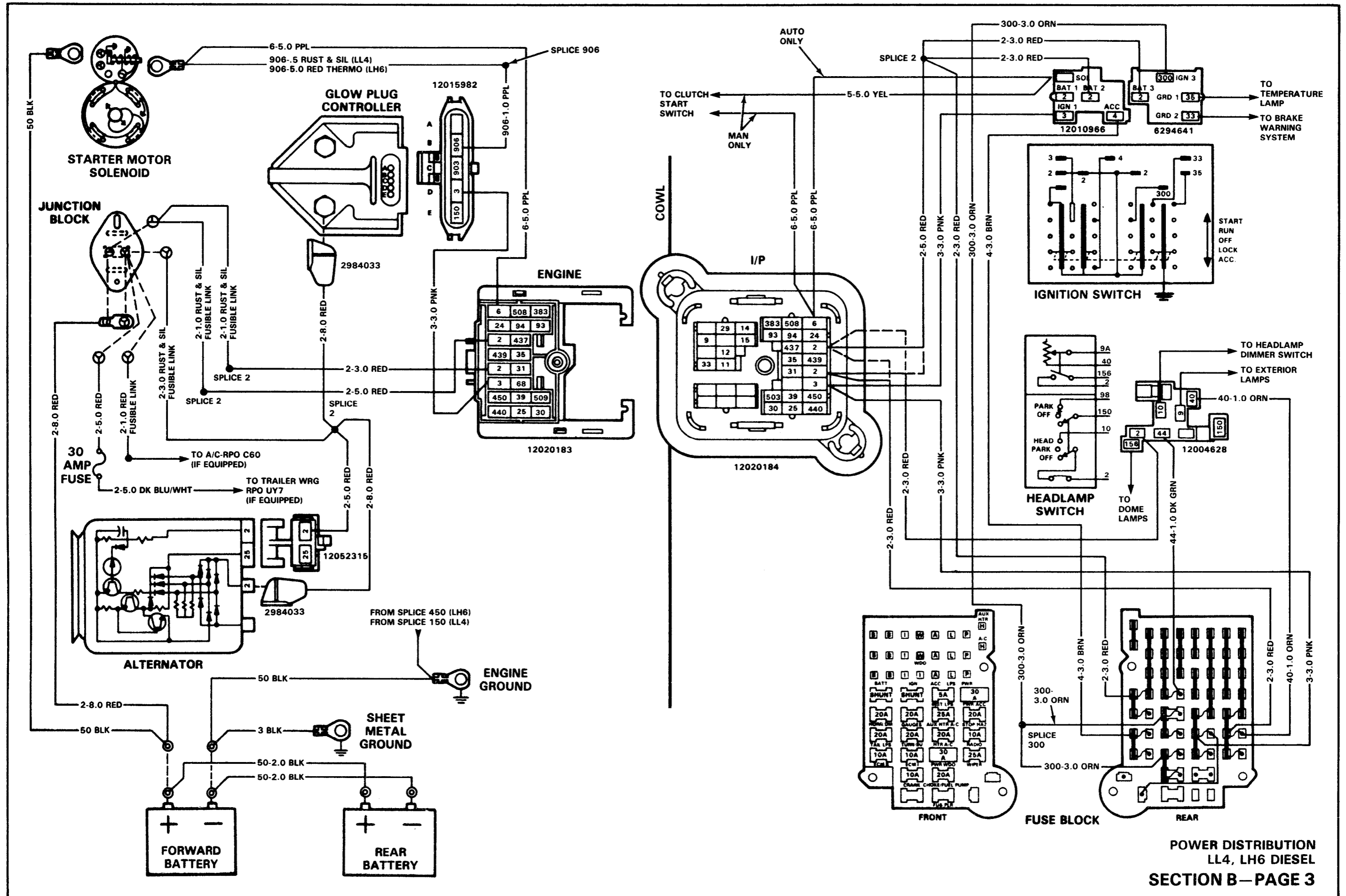

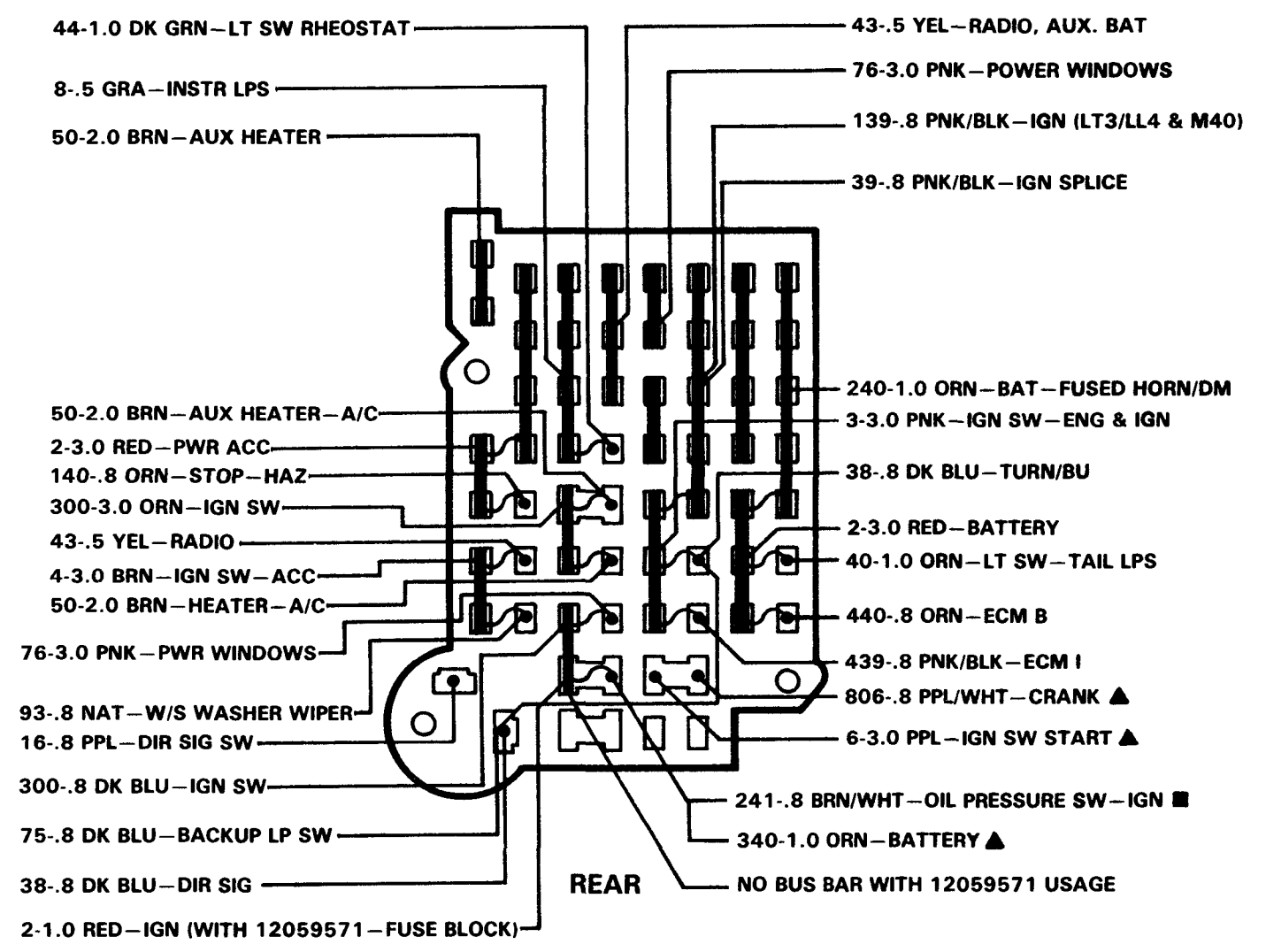
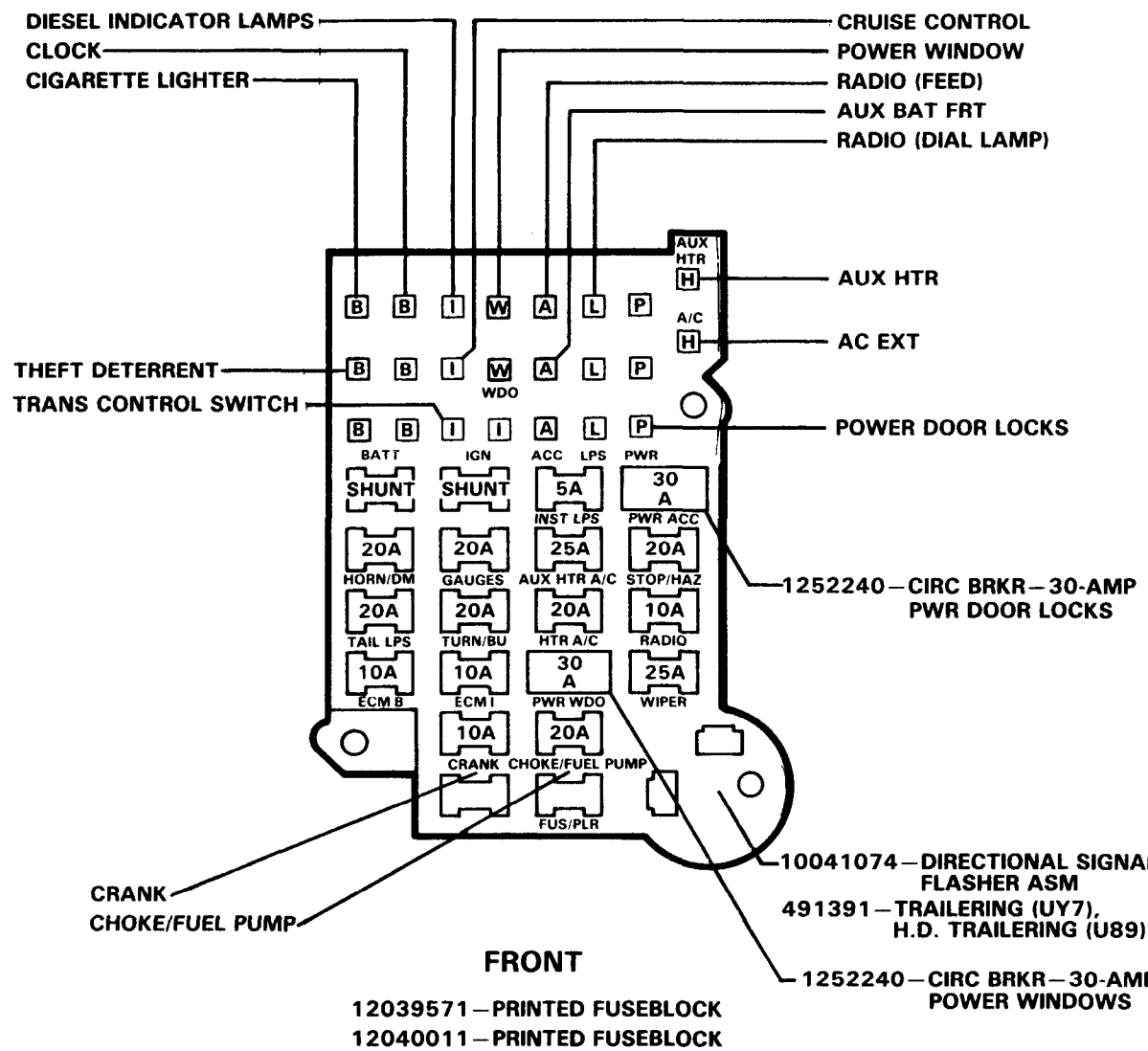

	COLOR	MALE CONN
A	BRN	12004887
B	BLK	12004886
H	DK GRA	12004740
I	NAT	12004888
L	GRN	12004885
P	RED	12004883
W	BLU	12004884

FUSES	AMP	COLOR
12004005	5	TAN
12004007	10	RED
12004009	20	YEL
12004010	25	WHT
12004011	30	LT GRN

▲ LB4/LO3/LO5/L19 ONLY
■ LT9 ONLY

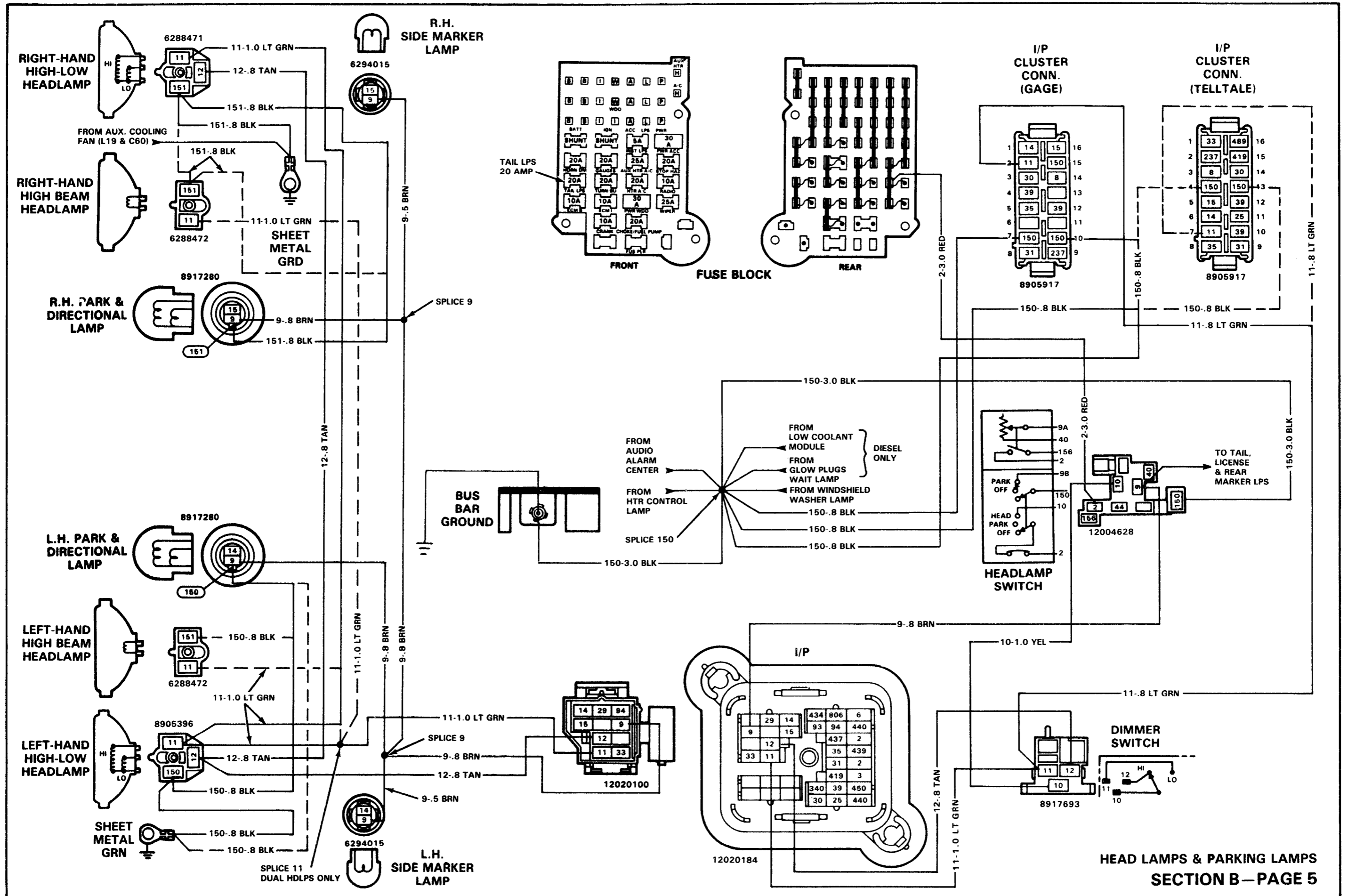

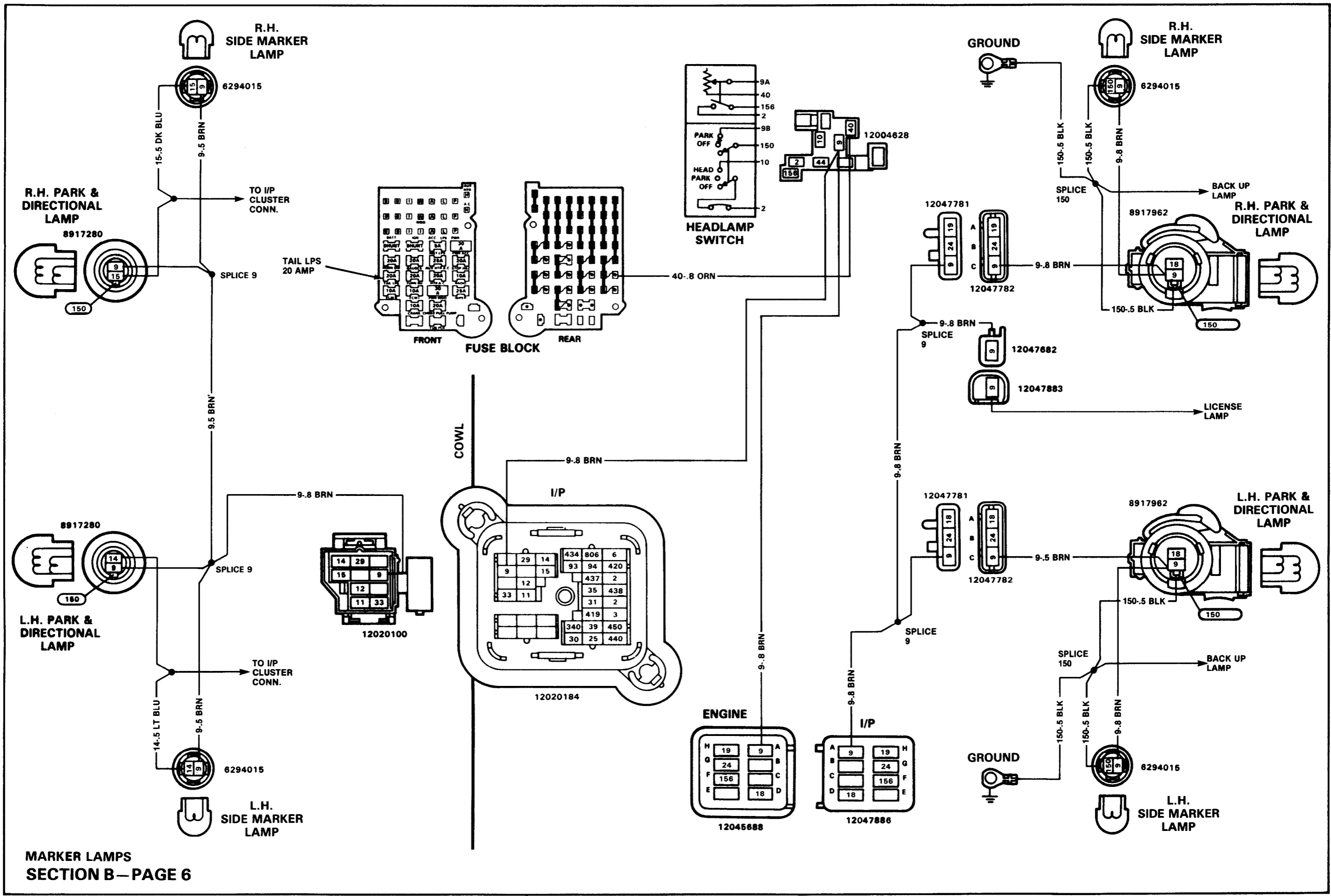

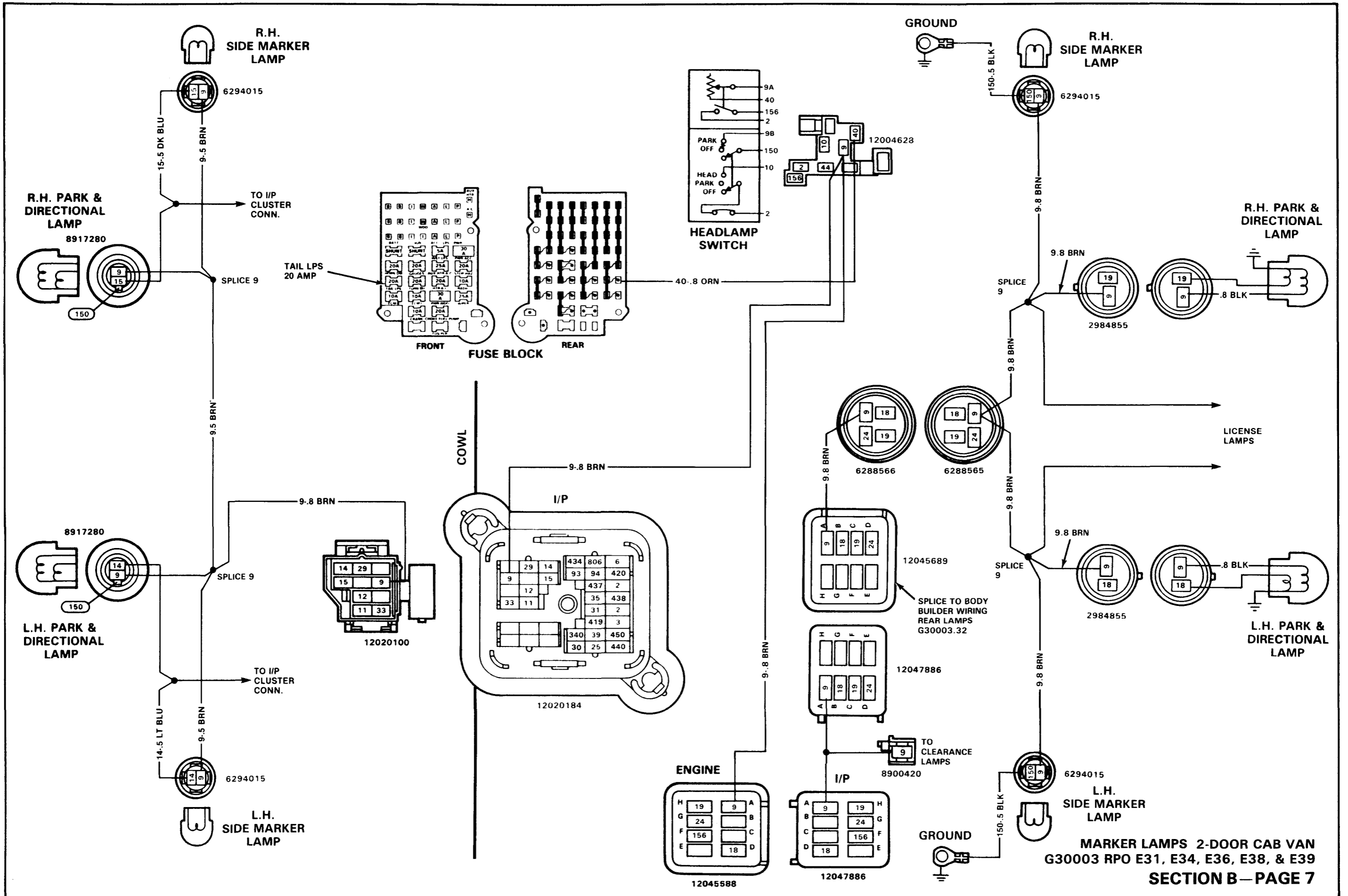

R.H. SIDE MARKER LAMP

6294015

15-5 DK BLU
9-5 BRN

R.H. PARK & DIRECTIONAL LAMP
8917280

TO I/P CLUSTER CONN.

SPLICE 9

TAIL LPS 20 AMP

FRONT FUSE BLOCK REAR

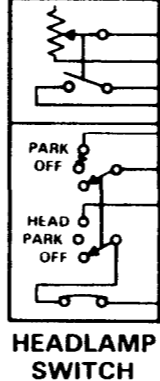

HEADLAMP SWITCH

40-8 ORN

GROUND

R.H. SIDE MARKER LAMP

6294015

9-8 BRN

R.H. PARK & DIRECTIONAL LAMP

SPLICE 9

9-8 BRN

2984855

LICENSE LAMPS

COWL

9-8 BRN

I/P

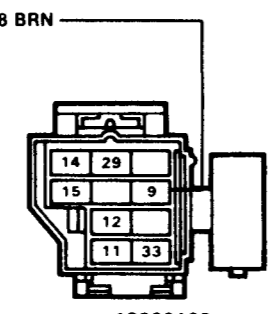

SPLICE 9

9-8 BRN

L.H. PARK & DIRECTIONAL LAMP
8917280

L.H. PARK & DIRECTIONAL LAMP

14-5 LT BLU
9-5 BRN

6294015

L.H. SIDE MARKER LAMP

TO I/P CLUSTER CONN.

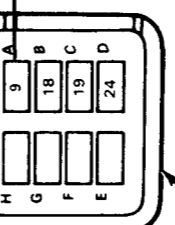
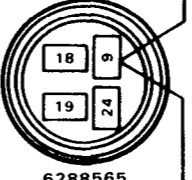
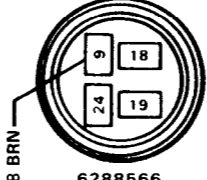
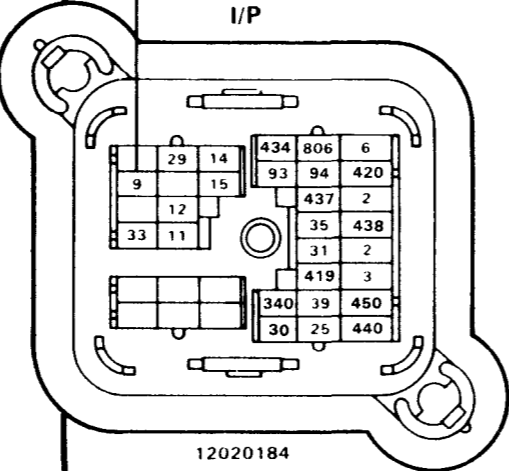

SPLICE TO BODY BUILDER WIRING REAR LAMPS G30003.32

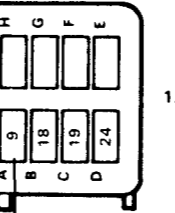

SPLICE 9

9-8 BRN

2984855

L.H. PARK & DIRECTIONAL LAMP

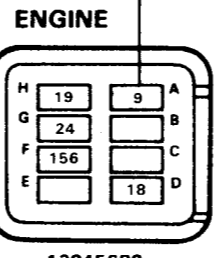

ENGINE

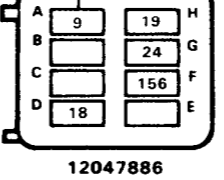

I/P

TO CLEARANCE LAMPS 8900420

GROUND

150-5 BLK

L.H. SIDE MARKER LAMP
6294015

MARKER LAMPS 2-DOOR CAB VAN
G30003 RPO E31, E34, E36, E38, & E39
SECTION B—PAGE 7

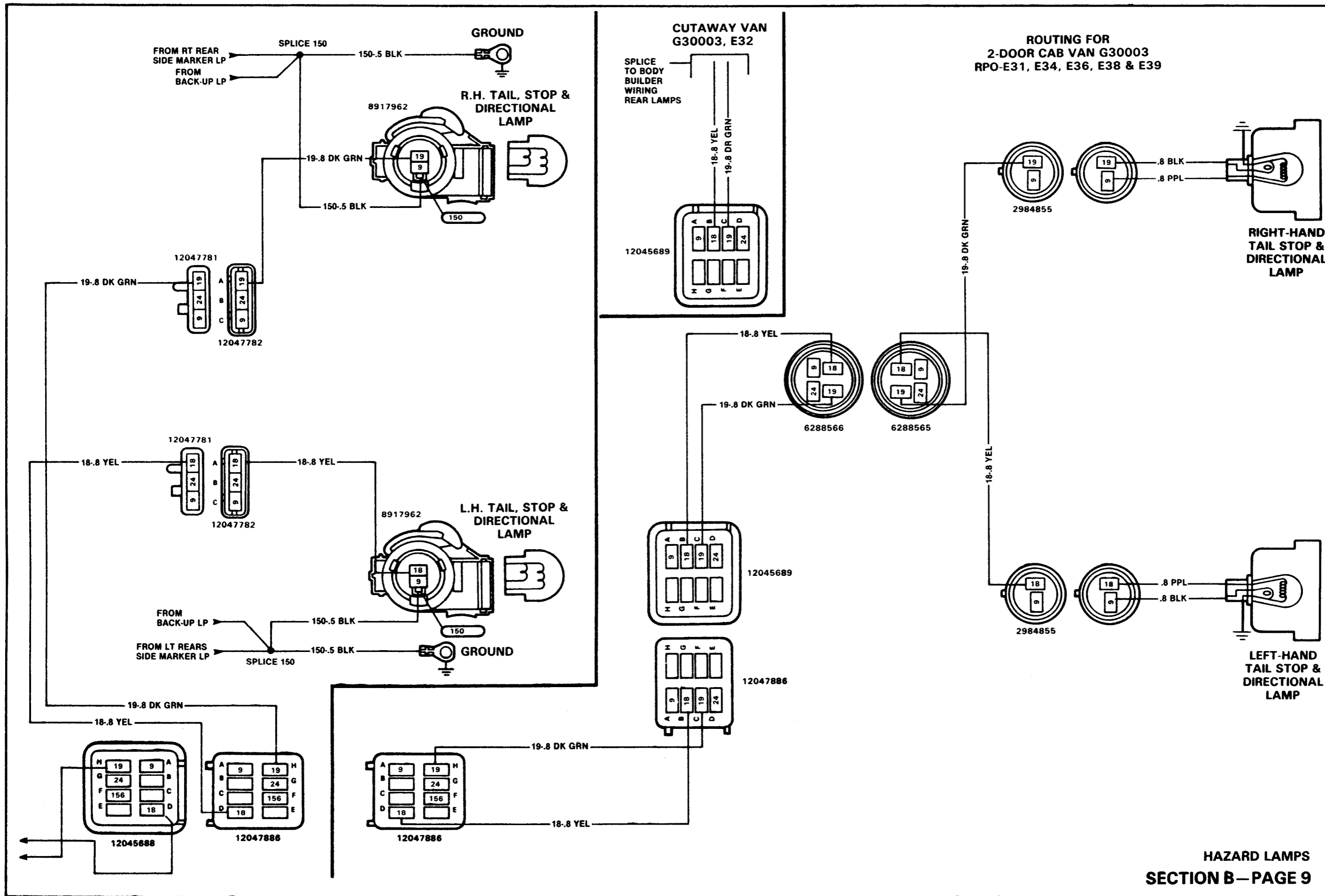

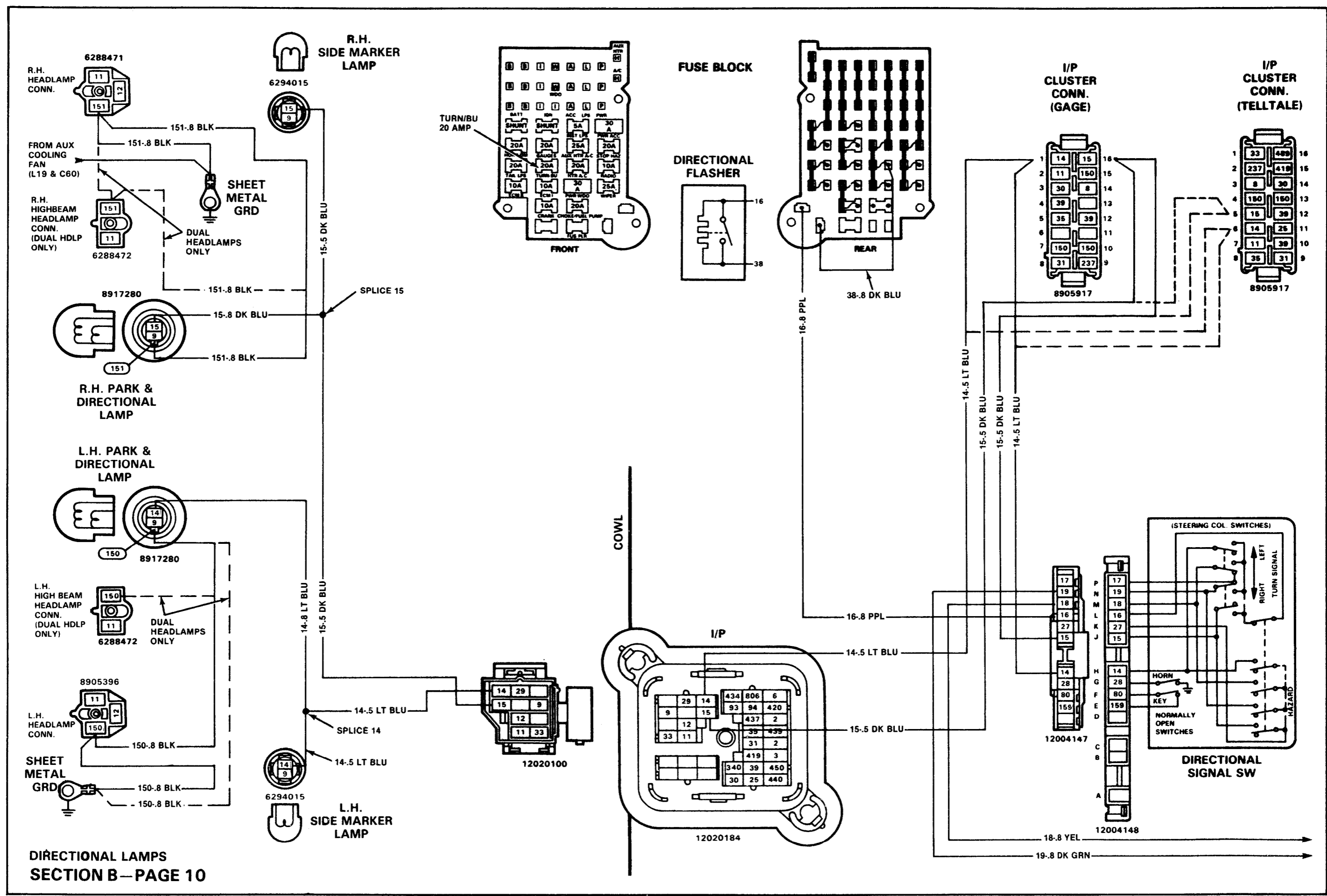

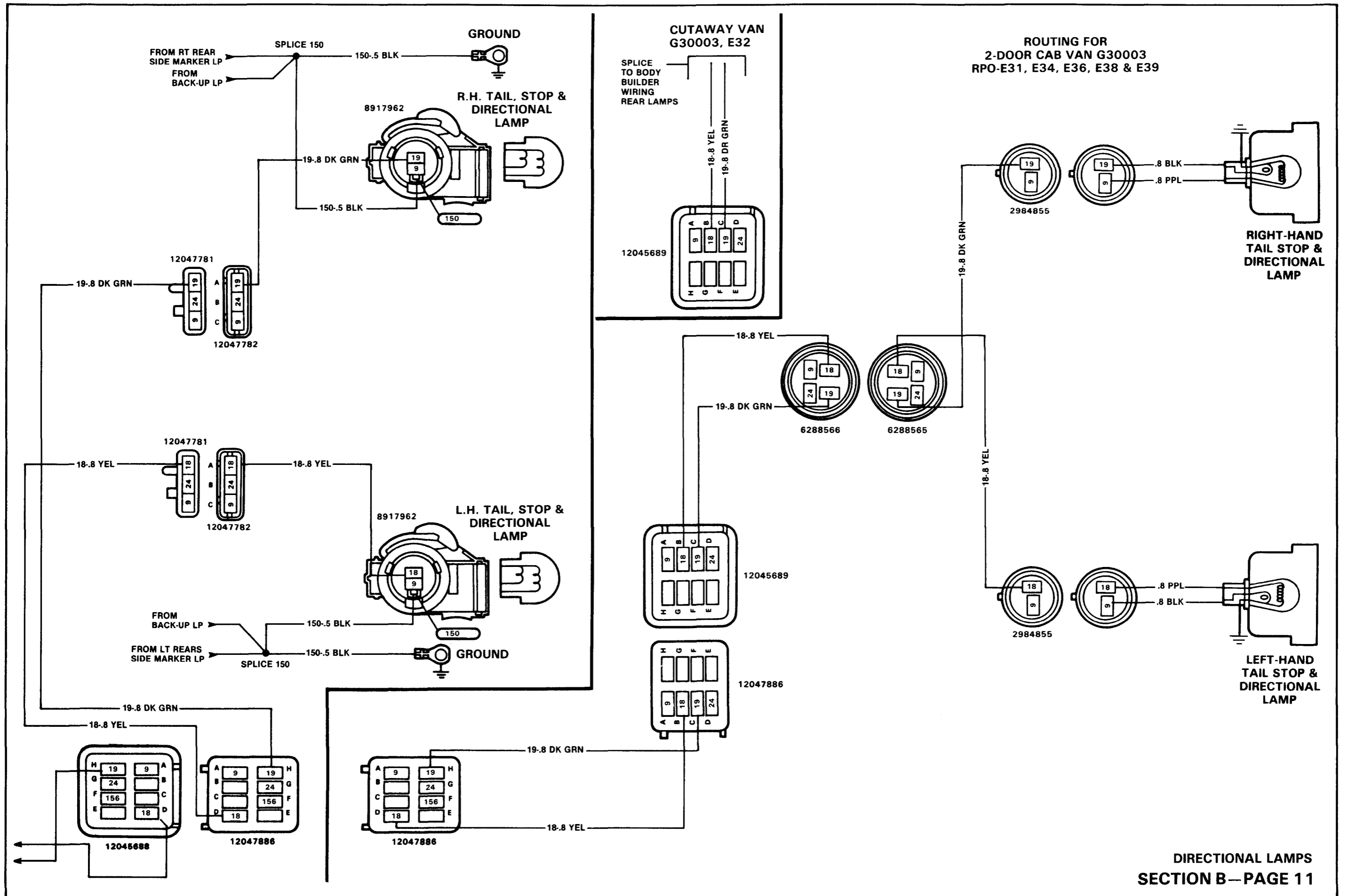

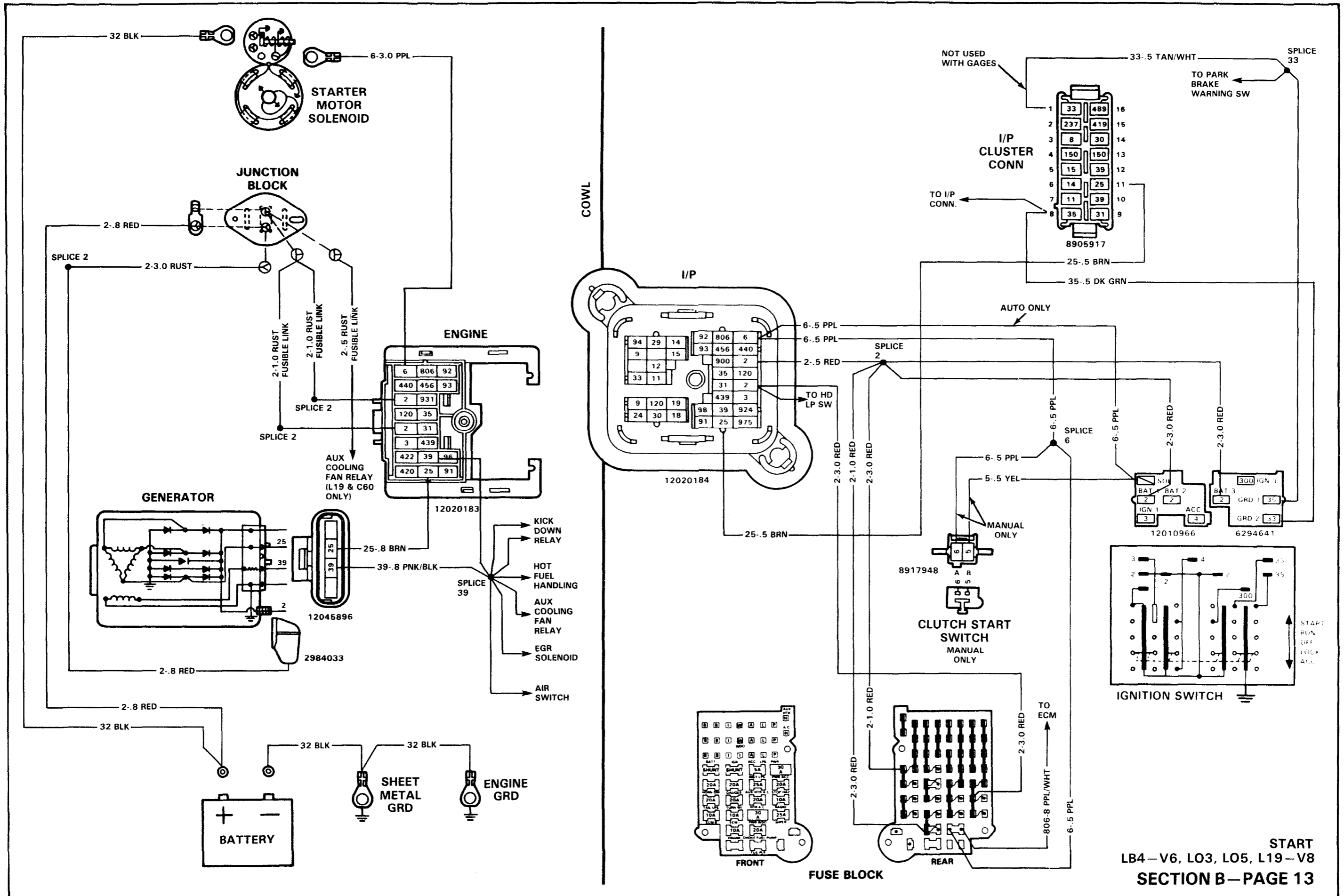

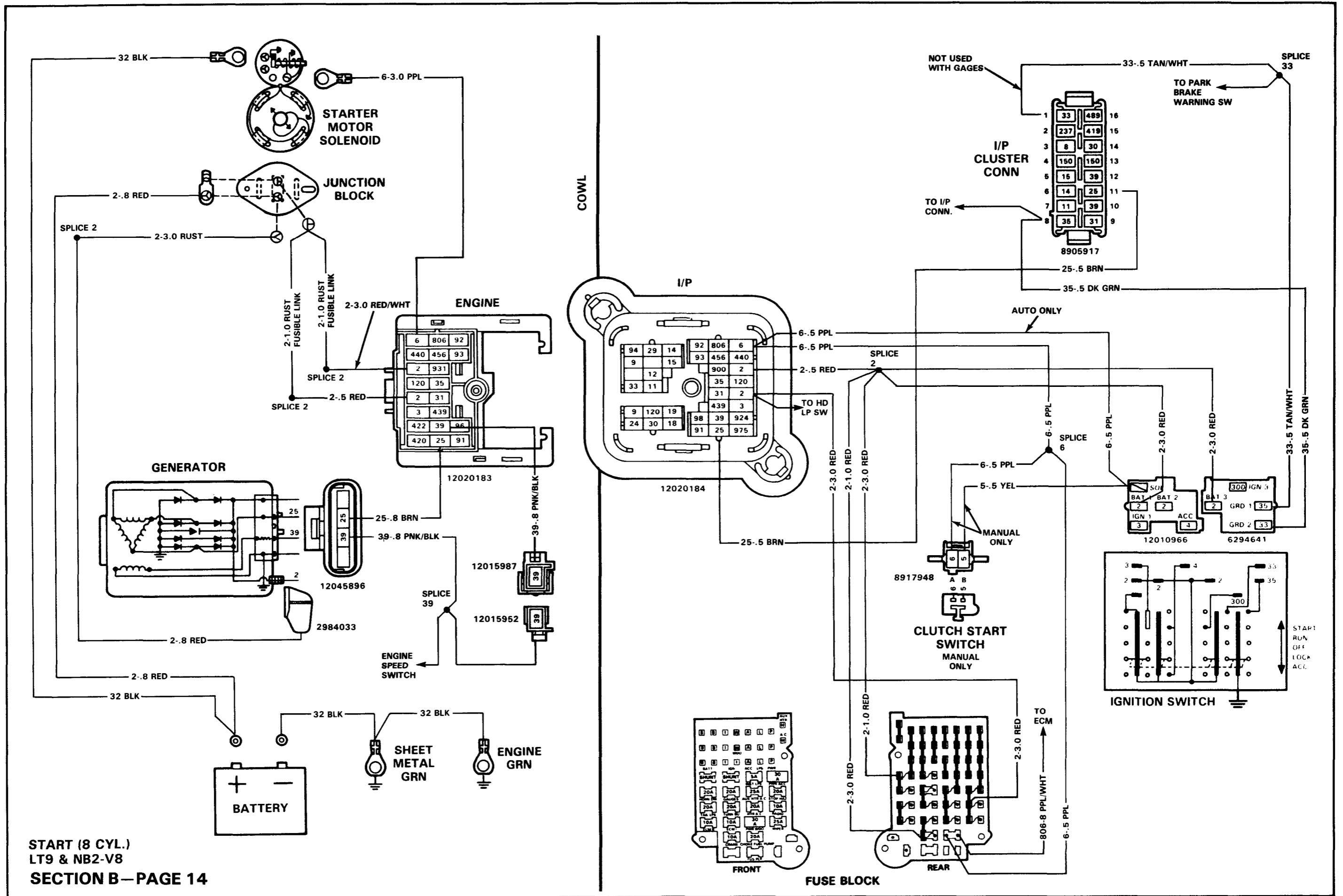

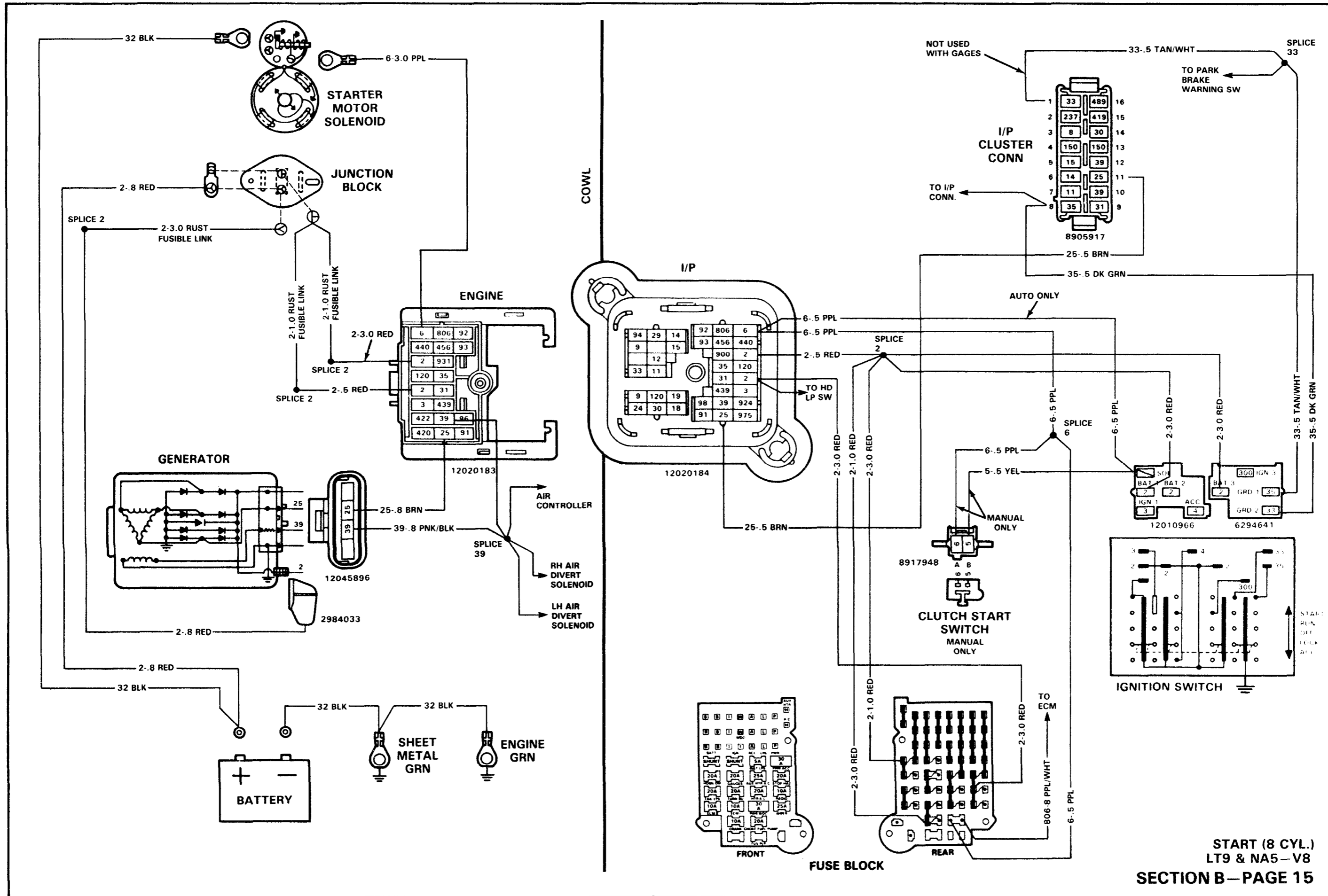

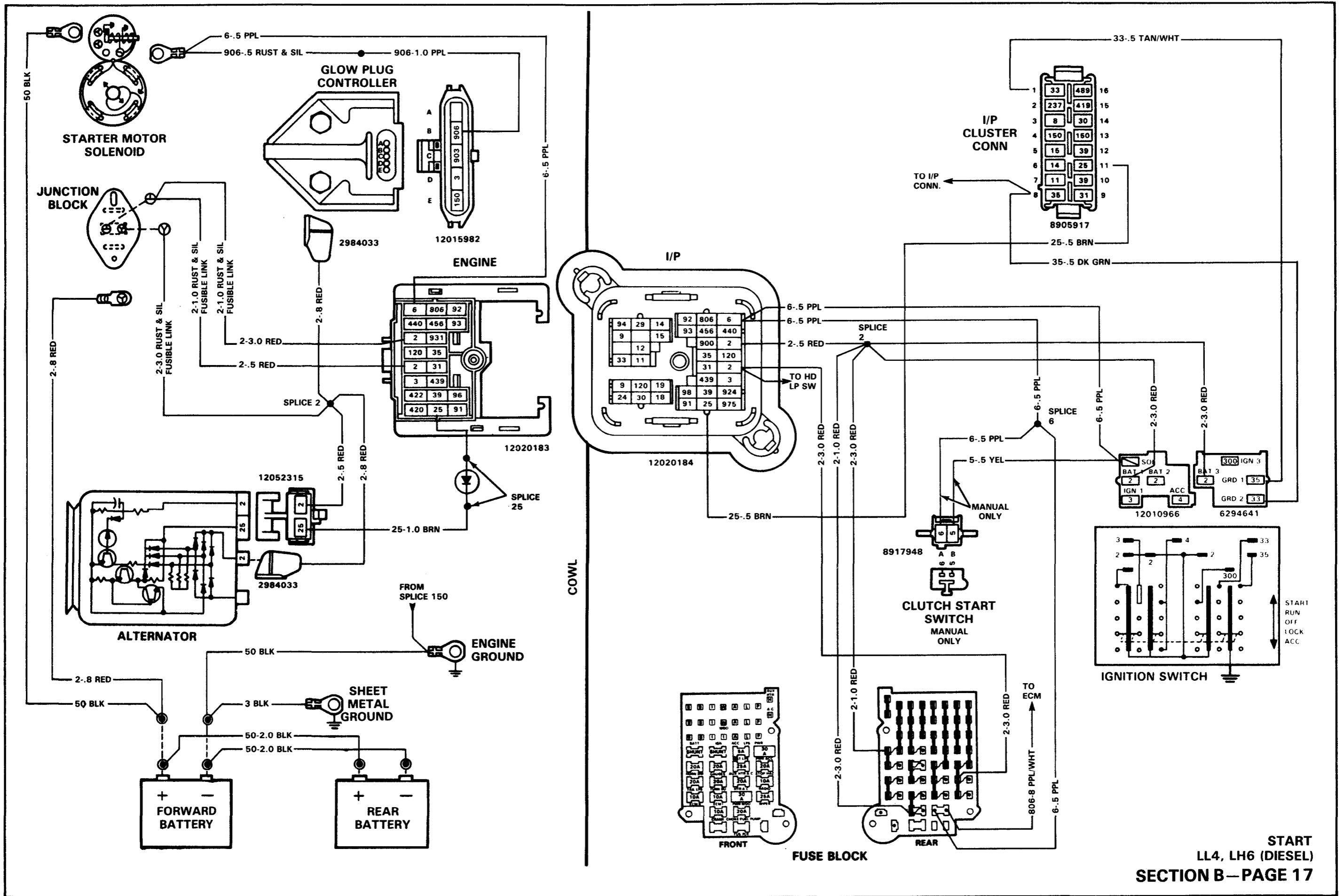

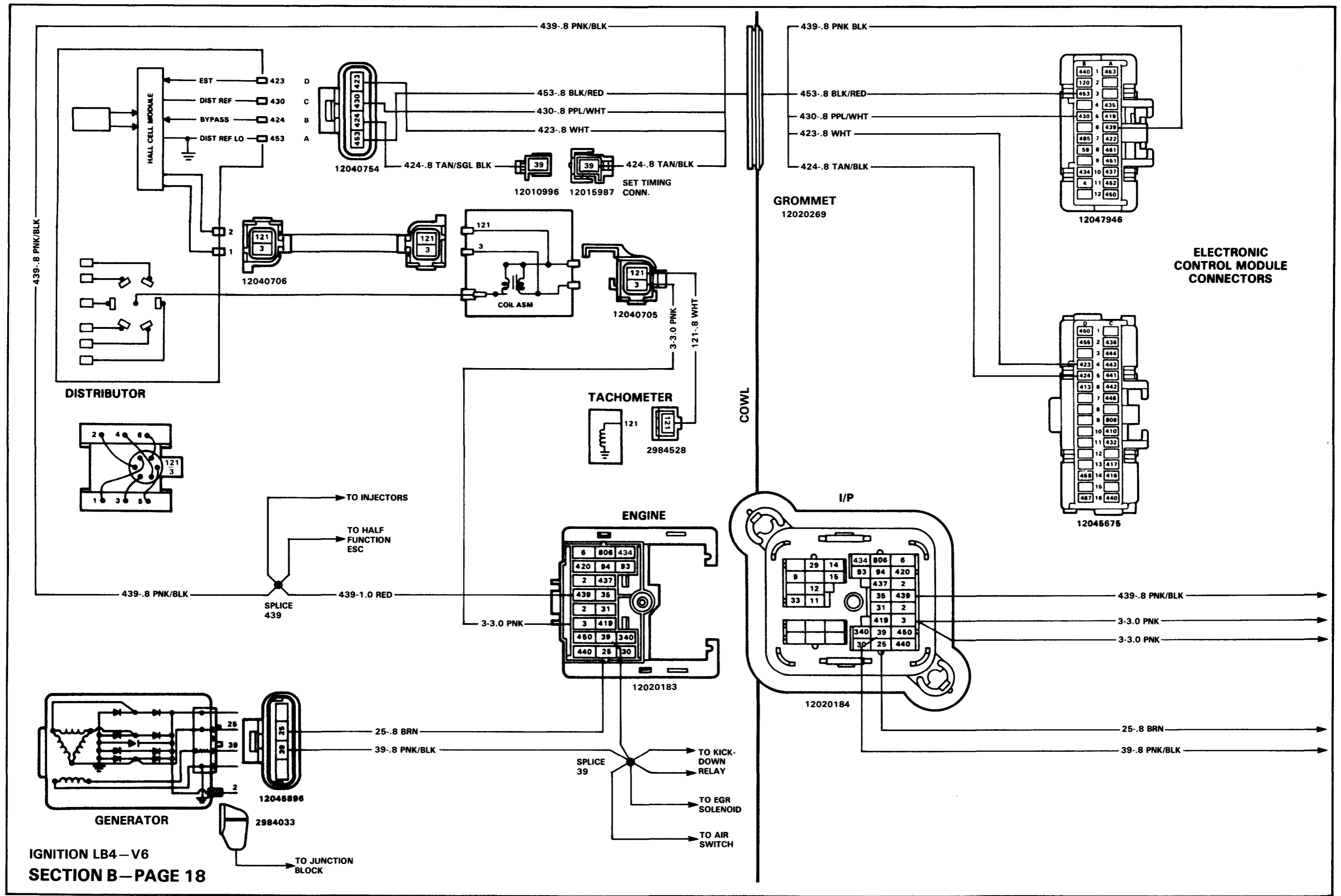

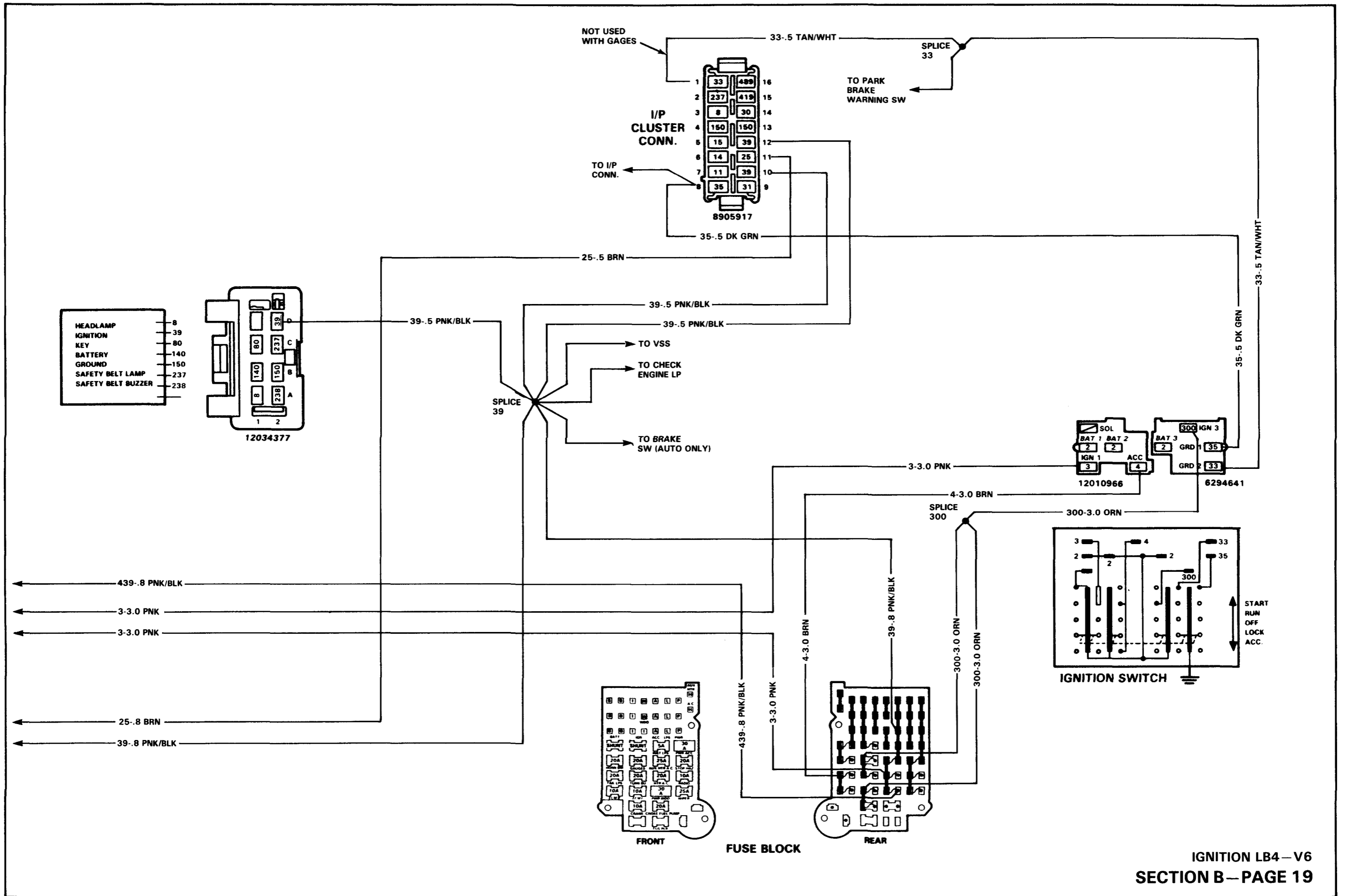

439-8 PNK/BLK

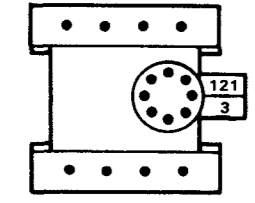
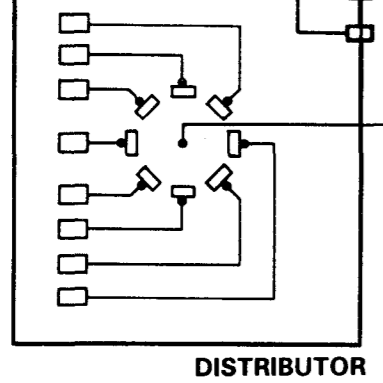
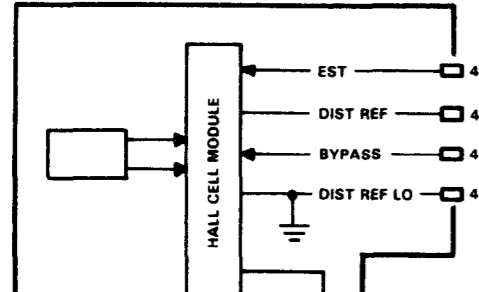

GENERATOR

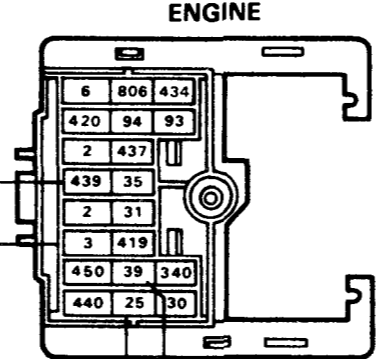
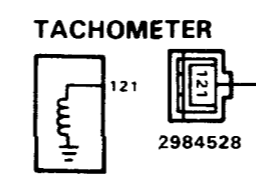
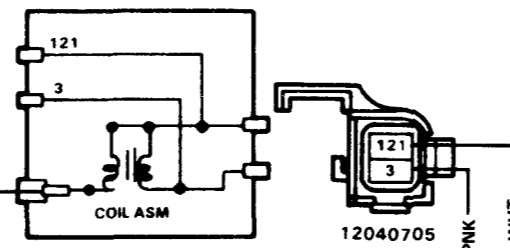
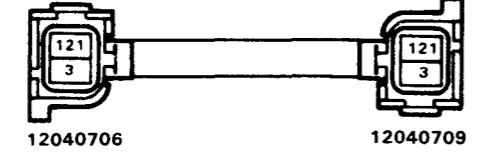
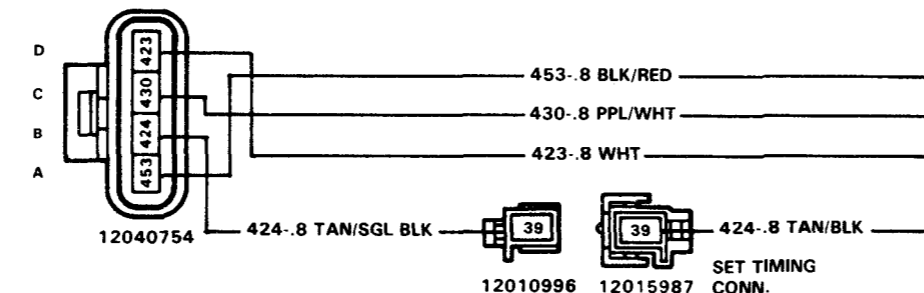

ENGINE

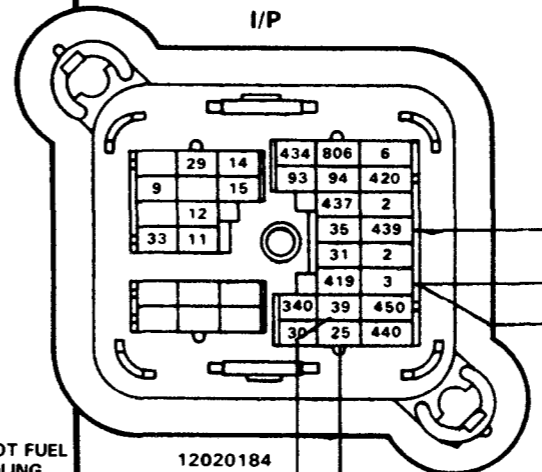

I/P

GROMMET
12020269

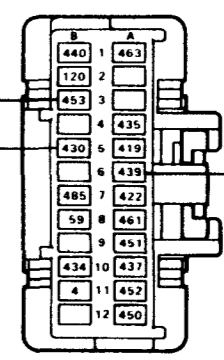

12047946

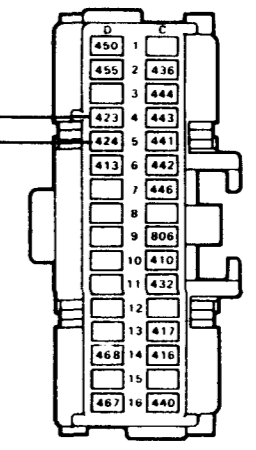

12045575

ELECTRONIC CONTROL MODULE CONNECTORS

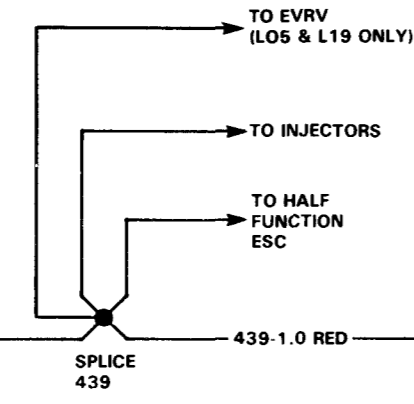

SPLICE
439

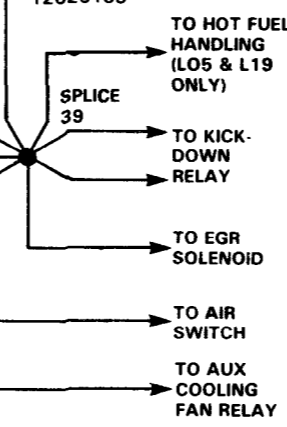

SPLICE
39

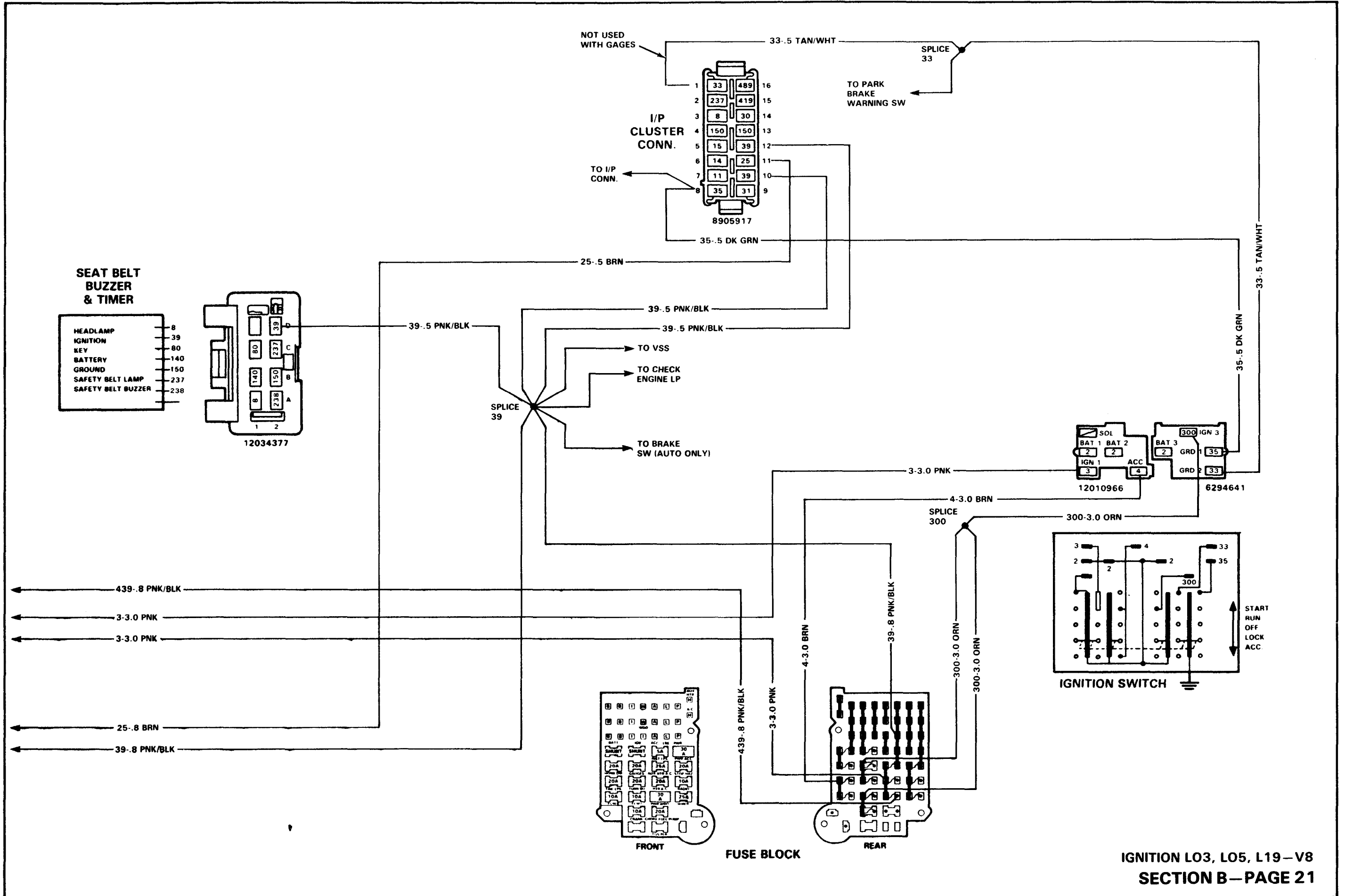

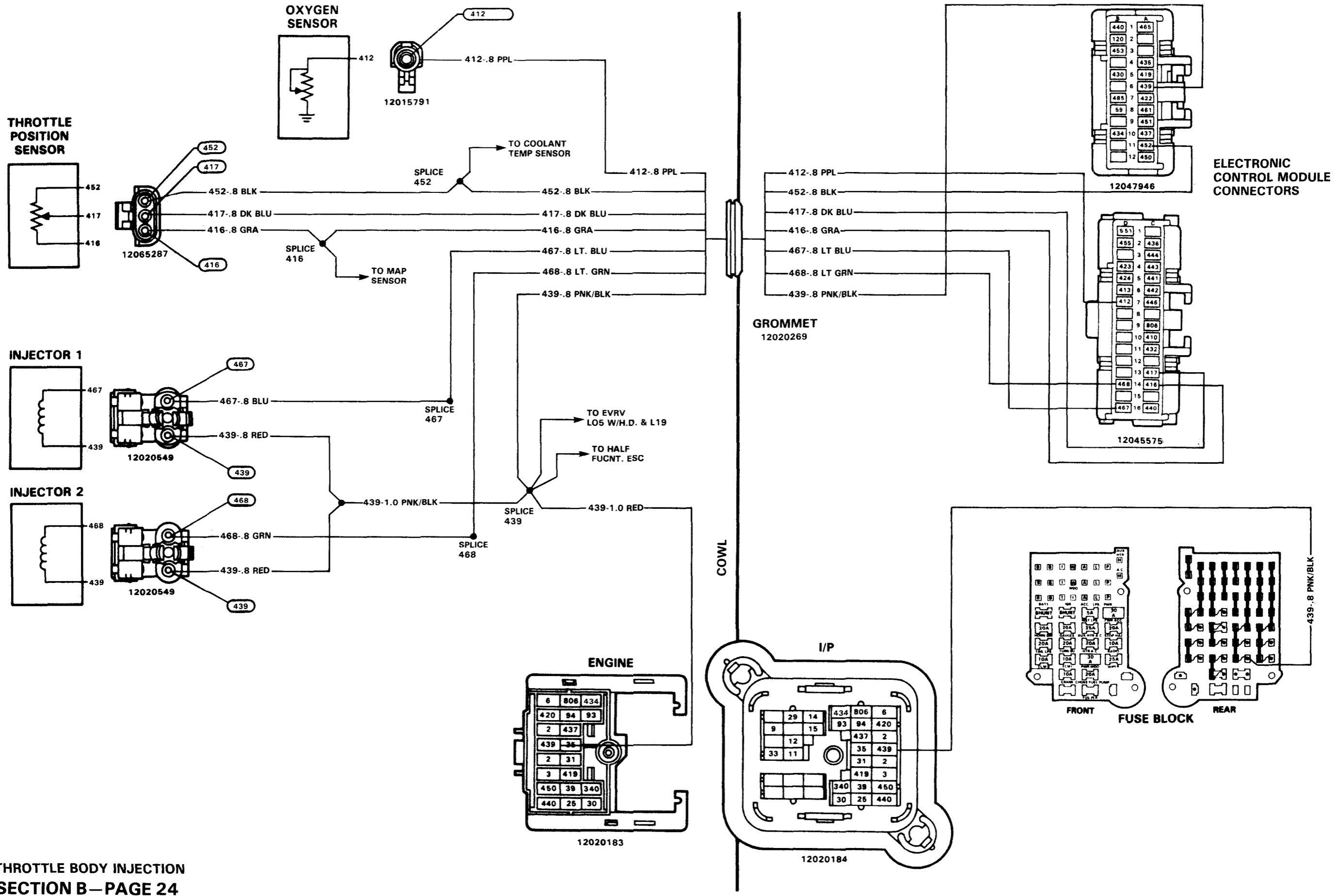

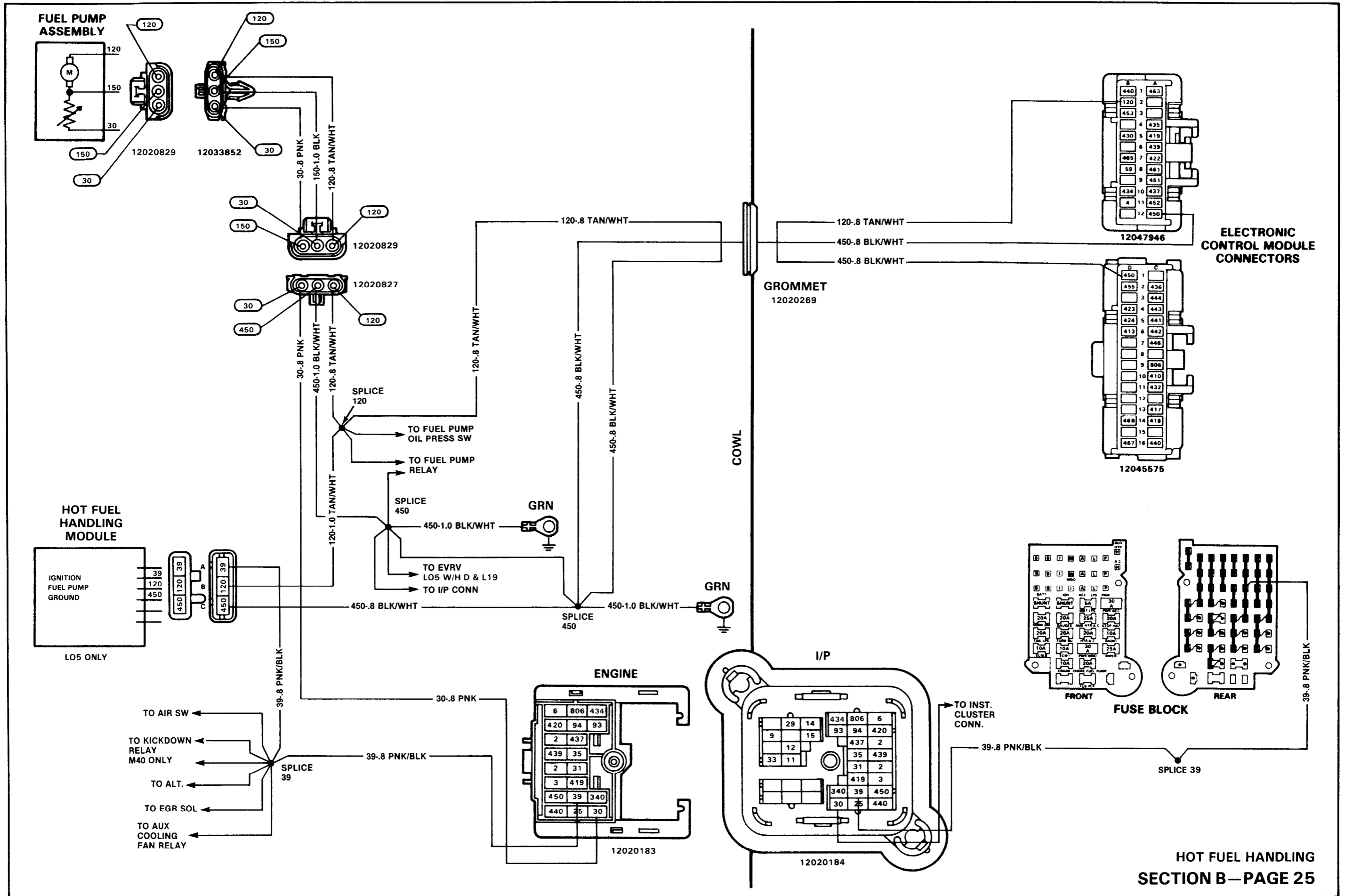

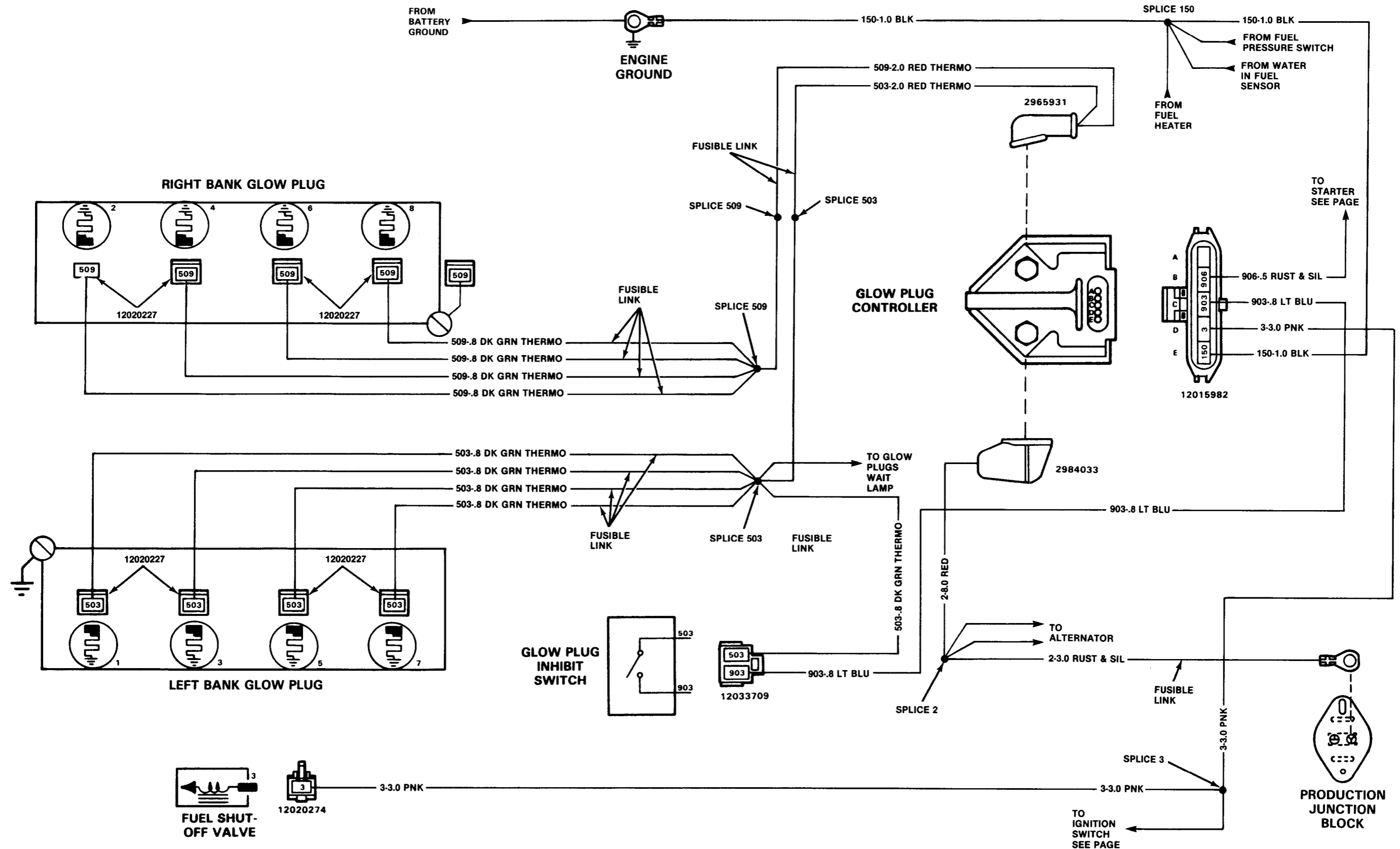

GLOW PLUGS—LL4 DIESEL
SECTION B—PAGE 26

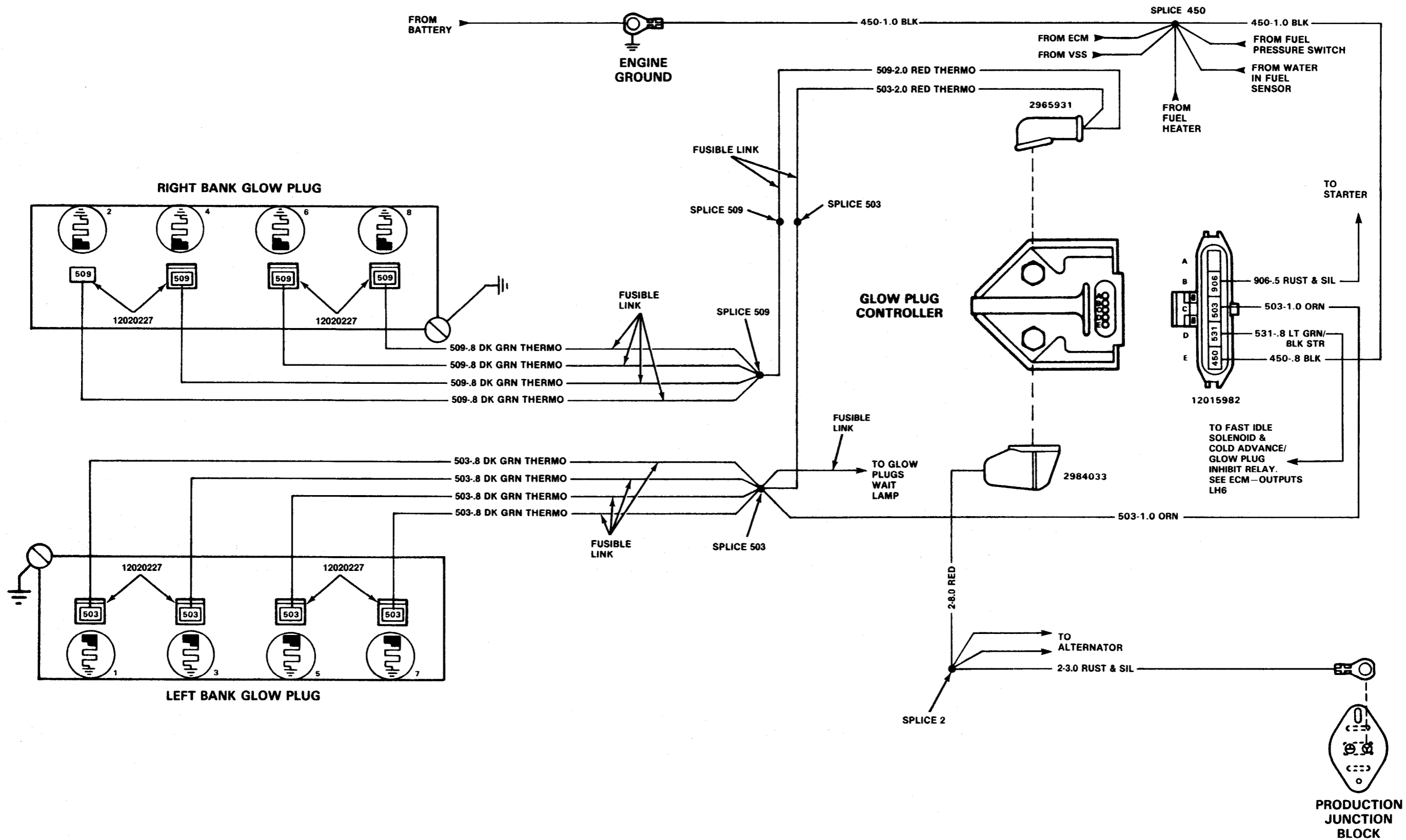

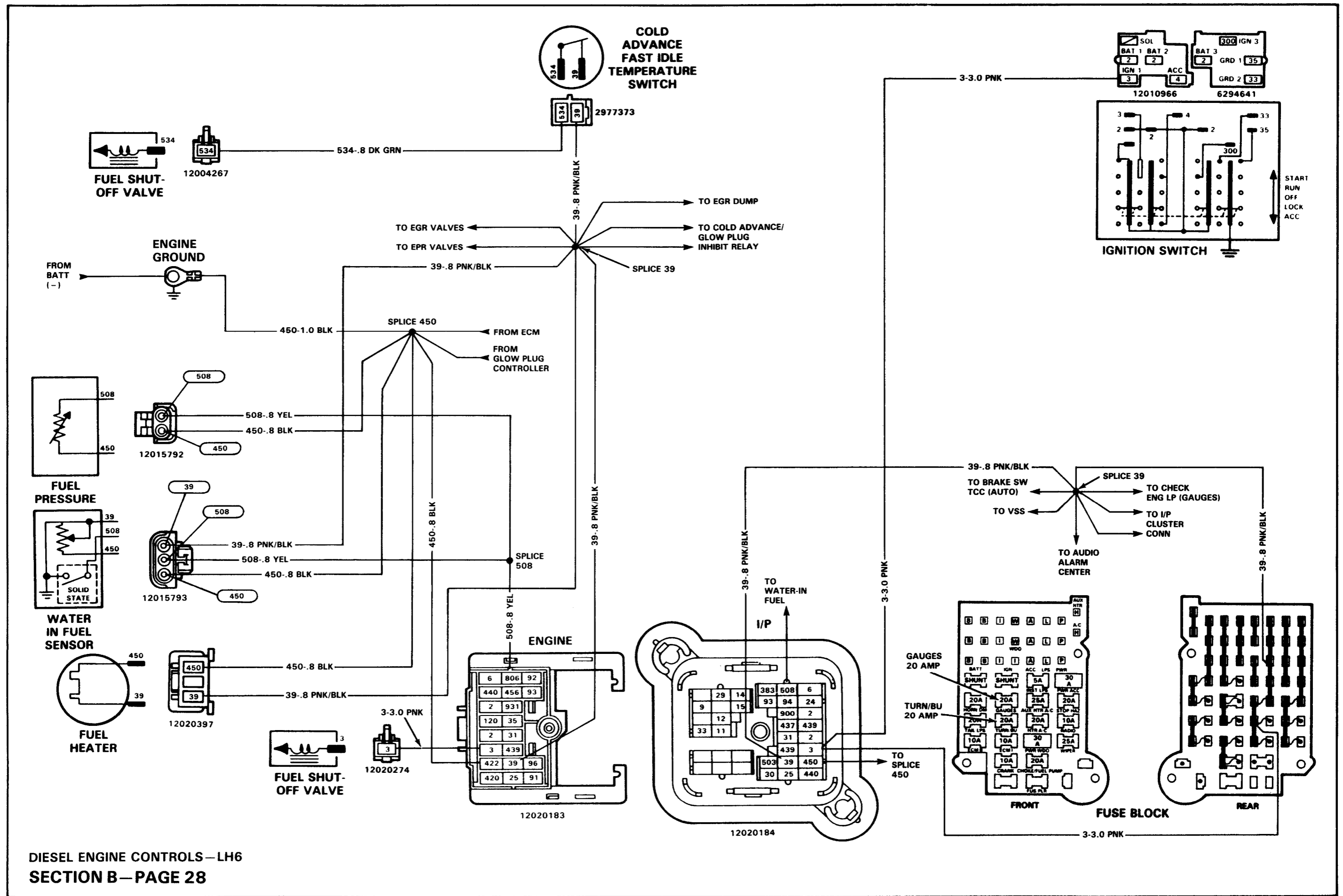

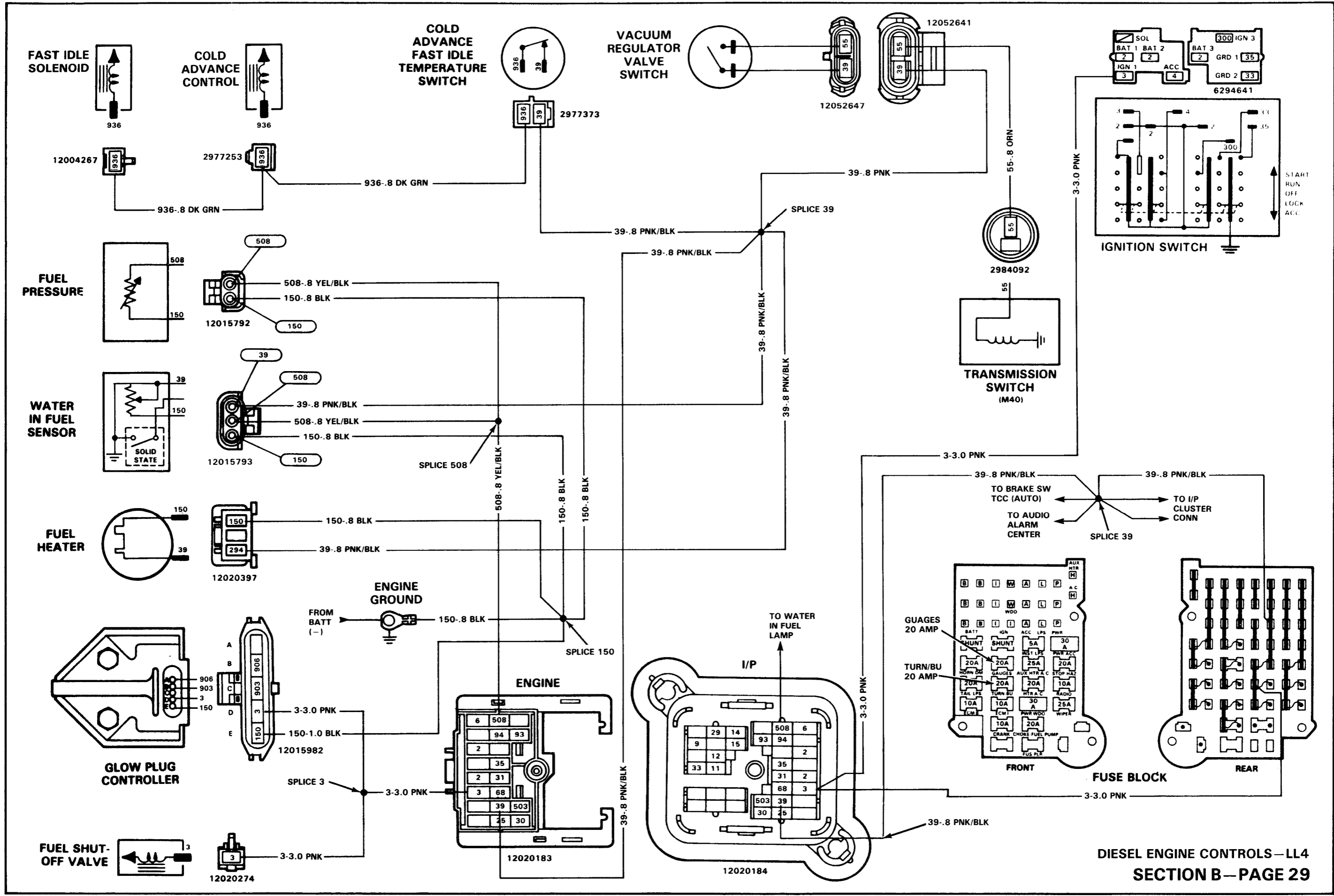

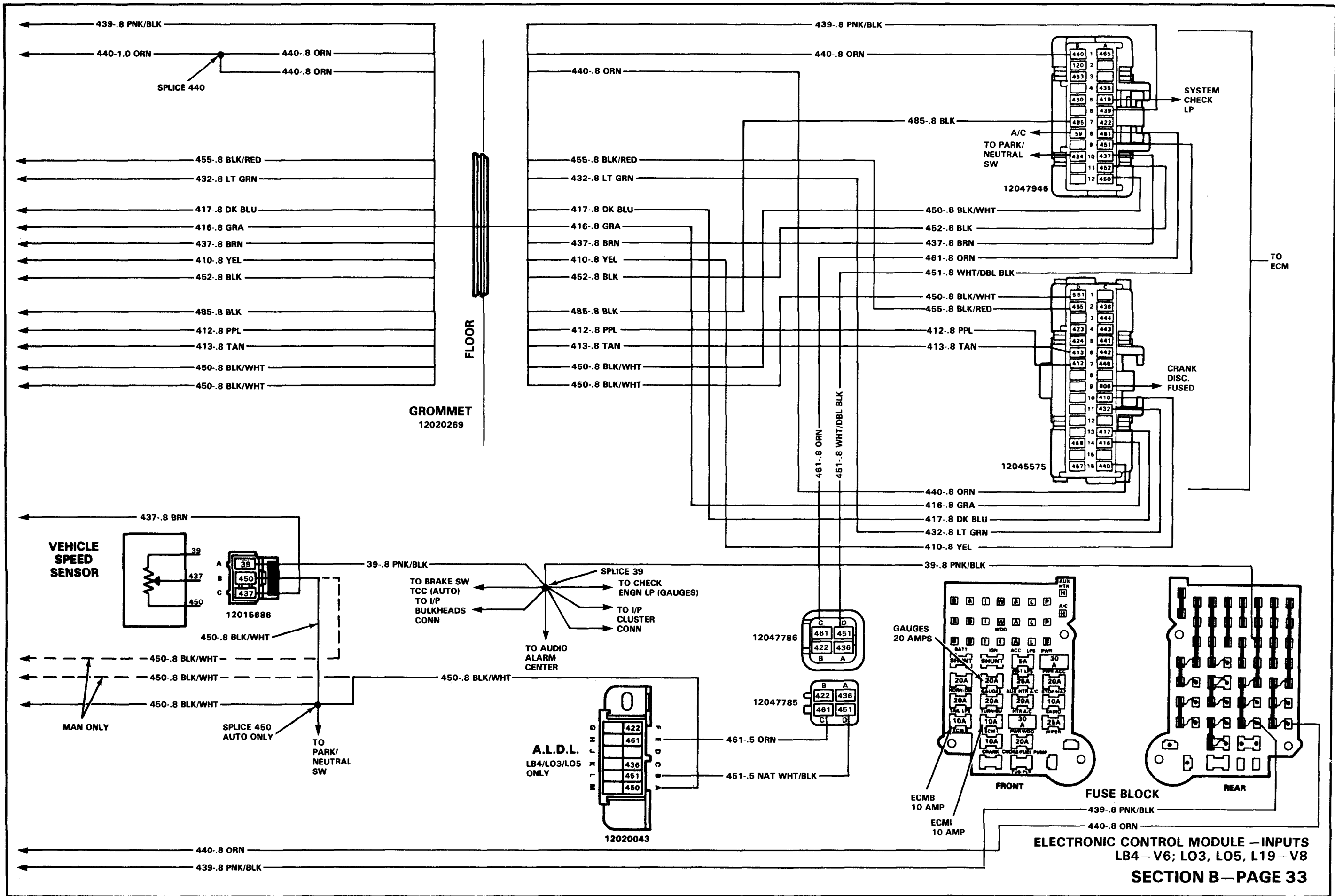

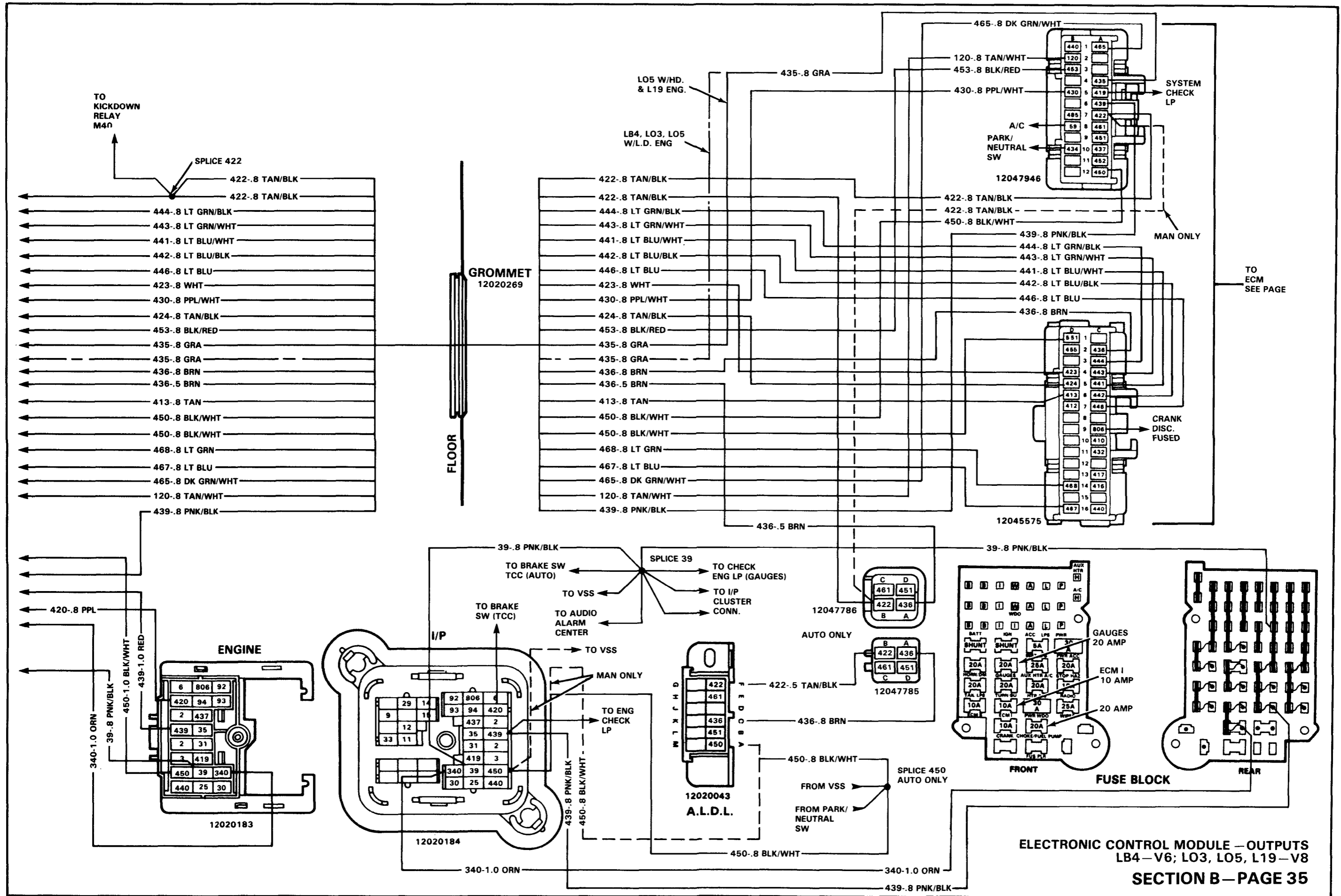

CIRCUIT NO.	WIRE SIZE	COLOR	CAVITY	DESCRIPTION
465	.8	DK GRN/WHT	A1	FUEL PUMP RELAY DRIVE
			A2	NOT USED
			A3	NOT USED
435	.8	GRA	A4	EGR SOLENOID
419	.8	BRN/WHT	A5	SYSTEM CHECK LAMP
439	.8	PNK/BLK	A6	12V IGNITION FUSED
* 422	.8	TAN/BLK	A7	TORQUE CONVERTER CLUTCH
461	.8	ORN	A8	SERIAL DATA
451	.8	WHT/DBL BLK	A9	ASS'Y LINE LINK/DIAG.
437	.8	BRN	A10	SPEED SENSOR
452	.8	BLK	A11	5V RETURN B
450	.8	BLK/WHT	A12	SYSTEM RETURN
440	.8	ORN	B1	12V BATTERY FUSED
120	.8	TAN/WHT	B2	ELEC FUEL PUMP FUSED FEED
453	.8	BLK/RED	B3	DISTRIBUTOR REF LOW
			B4	NOT USED
430	.8	PPL/WHT	B5	DISTRIBUTOR REF HIGH
			B6	NOT USED
485	.8	BLK	B7	SPARK RETARD CONTROL
59	.8	DK GRN	B8	AIR CONDITION
			B9	NOT USED
* 434	.8	ORN/BLK	B10	PARK/NEUTRAL SWITCH
			B11	NOT USED
			B12	NOT USED

* AUTO TRANS ONLY

CIRCUIT NO.	WIRE SIZE	COLOR	CAVITY	DESCRIPTION
			C1	NOT USED
436	.8	BRN	C2	AIR SWITCH SOLENOID
444	.8	LT GRN/BLK	C3	STEPPER COIL B LOW
443	.8	LT GRN/WHT	C4	STEPPER COIL B HIGH
441	.8	LT BLU/WHT	C5	STEPPER COIL A HIGH
442	.8	LT BLU/BLK	C6	STEPPER COIL A LOW
* 446	.8	LT BLU	C7	A/C CONTROL (4TH GEAR DISCRETE)
			C8	NOT USED
806	.8	PPL/WHT	C9	CRANK DISCRETE FUSED
410	.8	YEL	C10	COOLANT TEMPERATURE
432	.8	LT GRN	C11	MANIFOLD ABSOLUTE PRESS.
			C12	NOT USED
417	.8	DK BLU	C13	THROTTLE POSITION SENSOR
416	.8	GRA	C14	5V SENSOR REFERENCE
			C15	NOT USED
440	.8	ORN	C16	12V BATTERY FUSED
450	.8	BLK/WHT	D1	SYSTEM RETURN
455	.8	PPL	D2	5V RETURN A
			D3	NOT USED
423	.8	WHT	D4	HEI SPARK TIMING
424	.8	TAN/BLK	D5	HEI BYPASS
413	.8	TAN	D6	OXYGEN SENSOR LOW
412	.8	PPL	D7	OXYGEN SENSOR HIGH
			D8	NOT USED
			D9	NOT USED
			D10	NOT USED
			D11	NOT USED
			D12	NOT USED
			D13	NOT USED
468	.8	LT GRN	D14	INJECTOR B DRIVE
			D15	NOT USED
467	.8	LT BLU	D16	INJECTOR A DRIVE

* AUTO TRANS ONLY

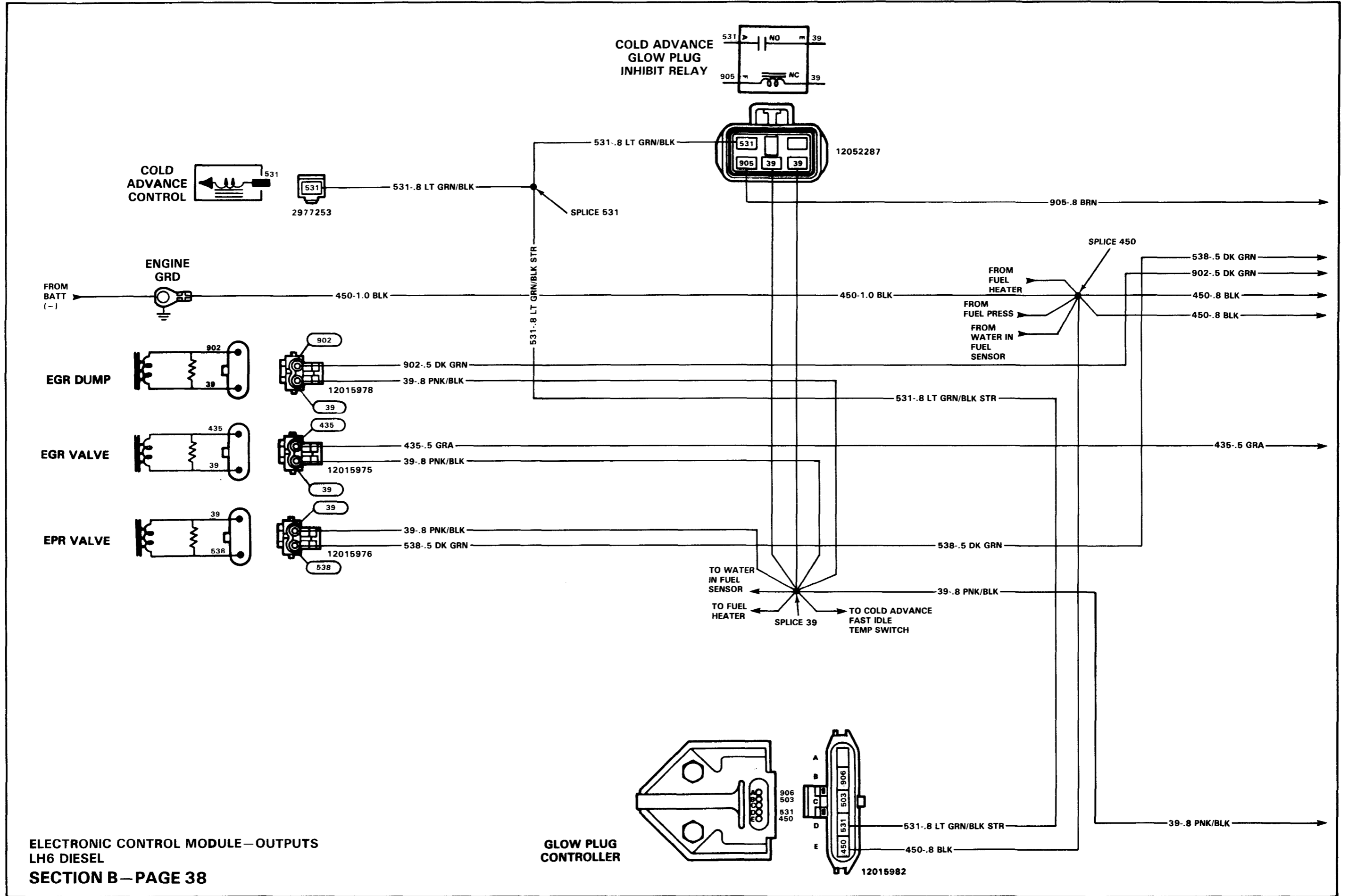

ELECTRONIC CONTROL MODULE—OUTPUTS
LH6 DIESEL
SECTION B—PAGE 38

CIRCUIT NO.	WIRE SIZE	COLOR	CAVITY	DESCRIPTION
432	.8	LT GRN	A1	MANIFOLD ABSOLUTE PRESS.
417	.8	DK BLU	A2	THROTTLE POSITION SWITCH
410	.8	YEL	A3	COOLANT TEMP. SENSOR
			A4	NOT USED
			A5	NOT USED
451	.8	WHT	A6	ASS'Y LINE LINK/DIAG.
			A7	NOT USED
121	.8	WHT	A8	ENGINE SPEED SENSOR
437	.8	BRN	A9	VEHICLE SPEED SENSOR
488	.8	LT GRN	A10	ASS'Y LINE LINK/DIAG.
			A11	NOT USED
416	.8	GRA	A12	THROTTLE POSITION SWITCH & MANIFOLD ABSOLUTE PRESS.
			B1	NOT USED
			B2	NOT USED
			B3	NOT USED
			B4	NOT USED
			B5	NOT USED
			B6	NOT USED
			B7	NOT USED
			B8	NOT USED
			B9	NOT USED
			B10	NOT USED
			B11	NOT USED
			B12	NOT USED

CIRCUIT NO.	WIRE SIZE	COLOR	CAVITY	DESCRIPTION
452	.8	BLK	C1	SYSTEM RETURN
450	.8	BLK	C2	SYSTEM GROUND
			C3	NOT USED
			C4	NOT USED
* 422	.8	TAN/BLK	C5	TORQUE CONVERTER CLUTCH
905	.8	BRN	C6	COLD ADVANCE/GLOW PLUG INHIBIT RELAY
			C7	NOT USED
			C8	NOT USED
			C9	NOT USED
435	.5	GRA	C10	EGR DIAGNOSTIC CONNECTOR
902	.5	DK GRN	C11	EGR SOLENOID
538	.5	DK GRN	C12	EGR SOLENOID
			C13	NOT USED
439	.8	PNK/PPL-BLK	C14	12V IGNITION FUSED
			C15	NOT USED
440	.8	ORN	C16	12V BATTERY FUSED
			D1	NOT USED
			D2	NOT USED
			D3	NOT USED
			D4	NOT USED
			D5	NOT USED
			D6	NOT USED
			D7	NOT USED
			D8	NOT USED
			D9	NOT USED
			D10	NOT USED
			D11	NOT USED
			D12	NOT USED
			D13	NOT USED
			D14	NOT USED
			D15	NOT USED
			D16	NOT USED

* AUTO TRANS ONLY

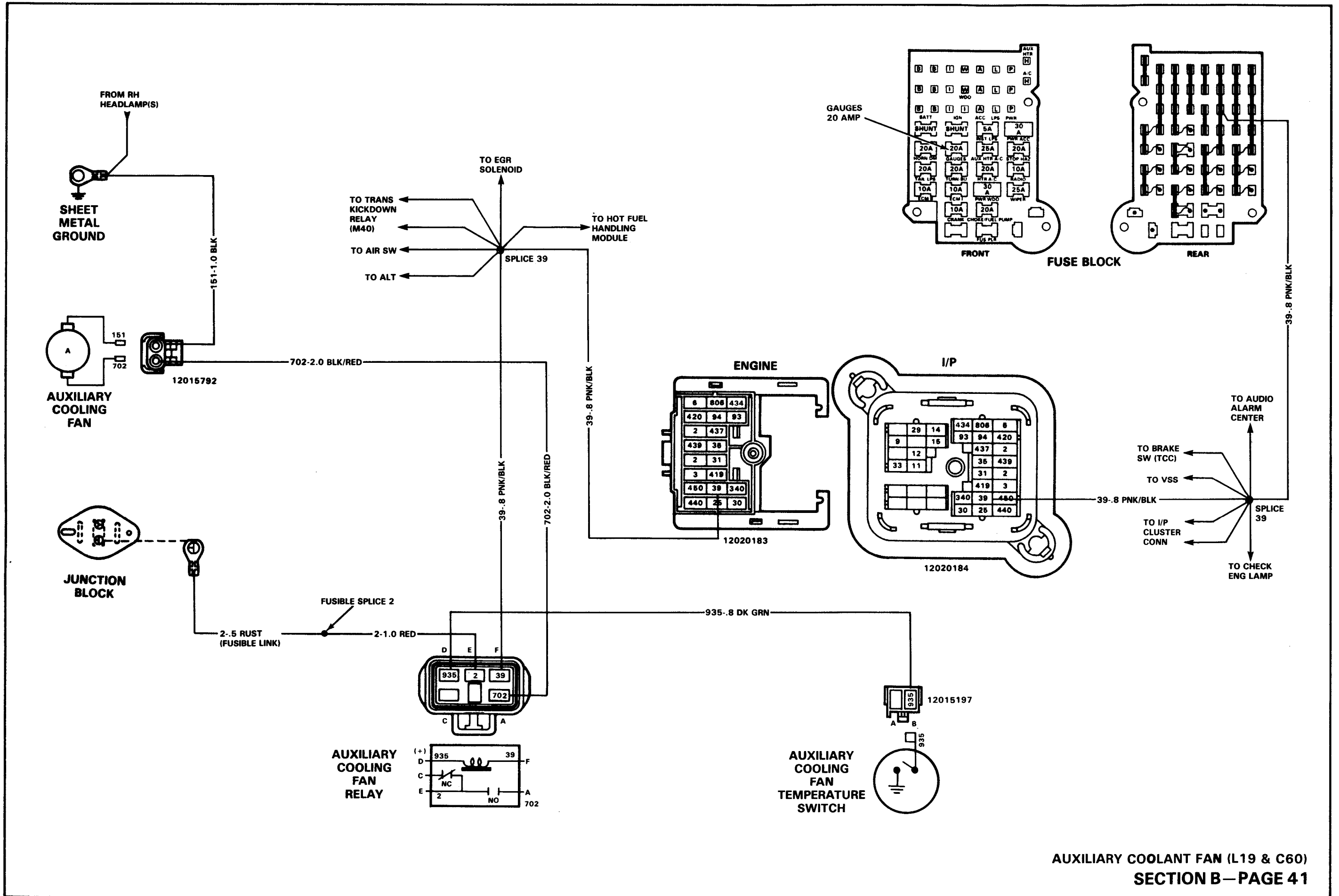

AUXILIARY COOLANT FAN (L19 & C60)
SECTION B—PAGE 41

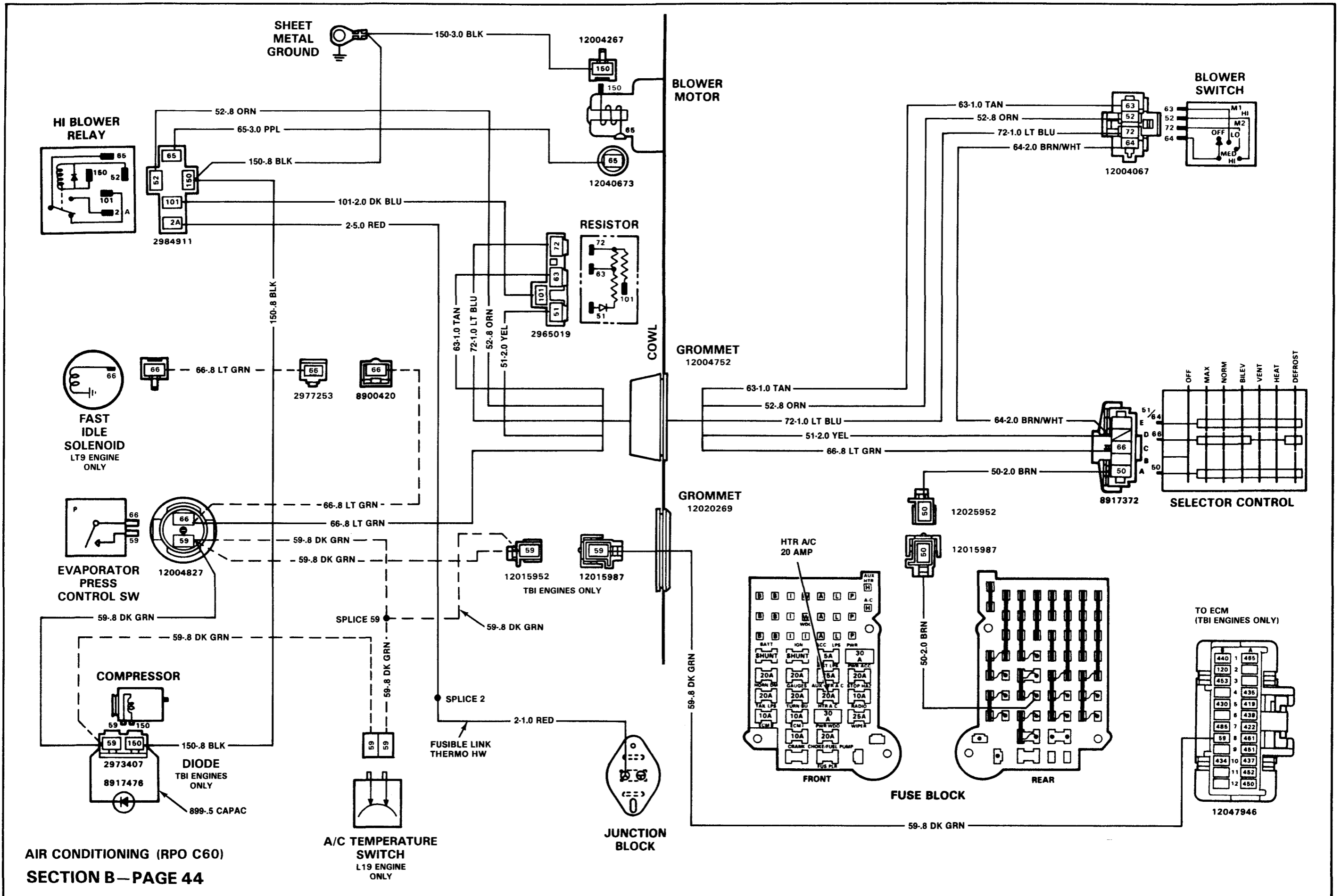

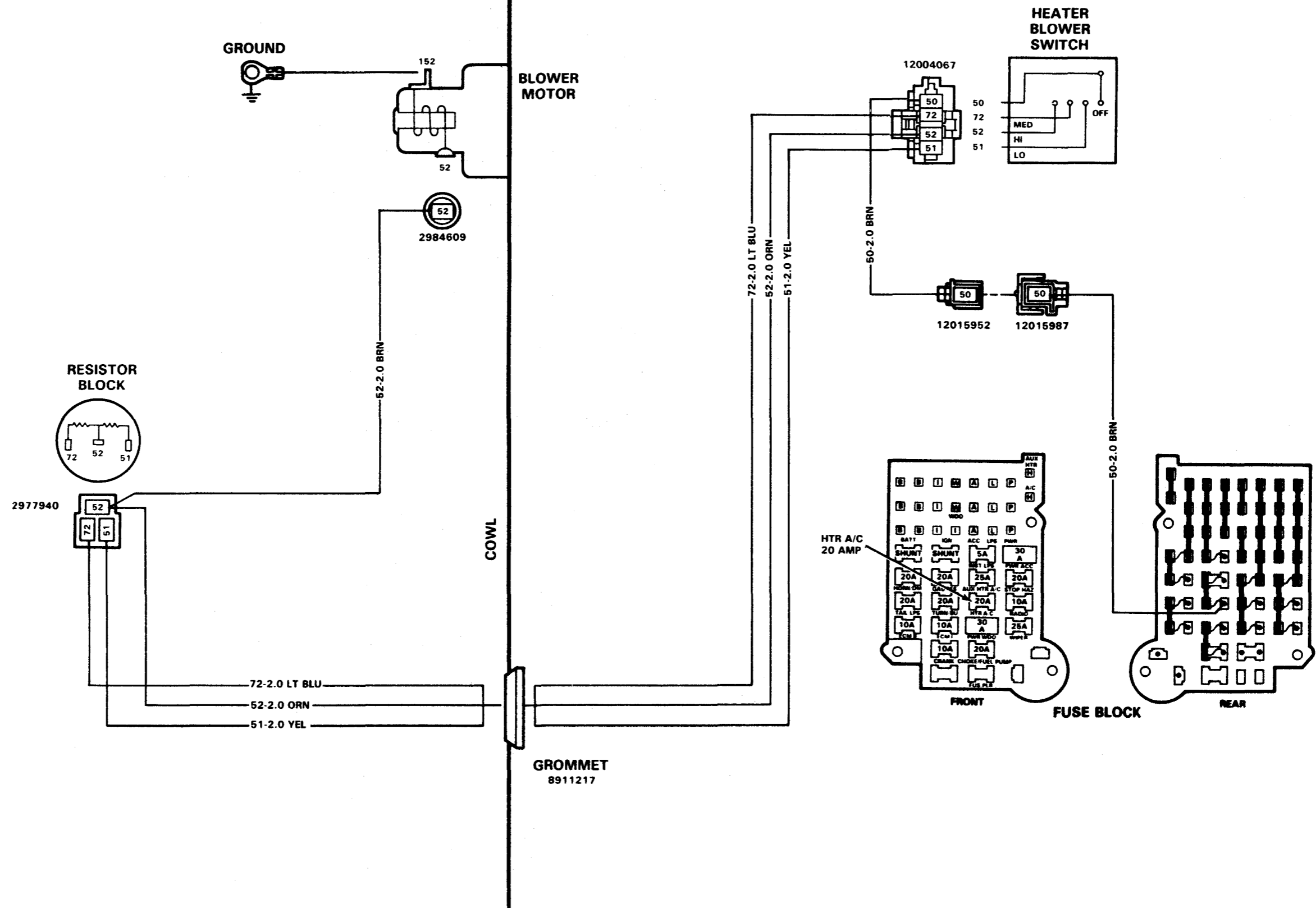

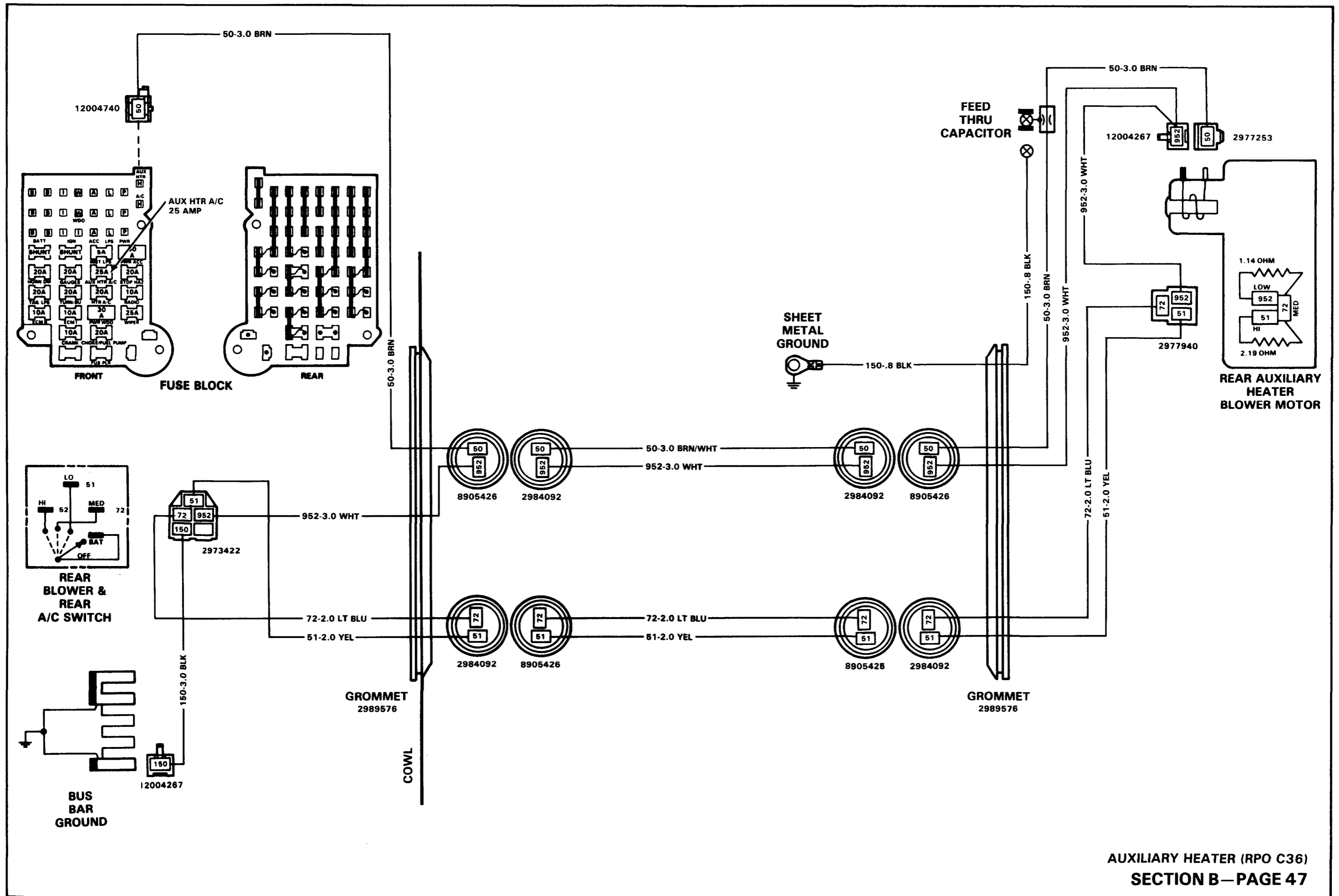

I/P
CLUSTER
CONN.
(TELLTALE)

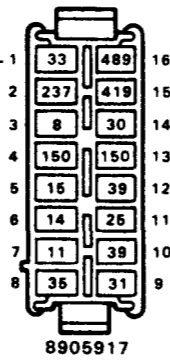

8905917

I/P
CLUSTER
CONN.
(GAGE)

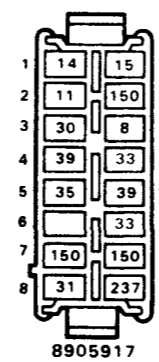

8905917

LH6/LL4
ONLY

LB4/L03
L05/L19
ONLY

33-5 TAN/WHT

33-5 TAN/WHT

33-5 TAN/WHT

33-5 TAN/WHT

SPLICE 33

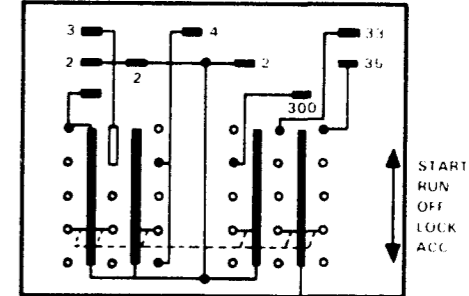
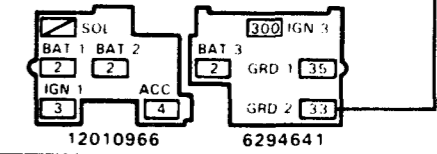

IGNITION SWITCH

PARK BRAKE
WARNING SWITCH

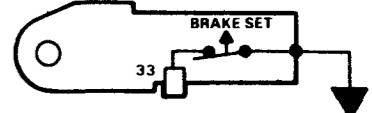

12004267

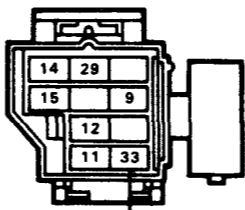

12020100

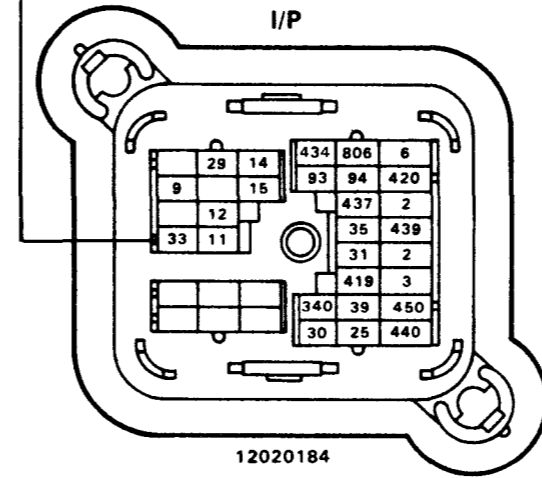

12020184

33-8 TAN/WHT

33-8 TAN/WHT

6288585

12004635

12004635

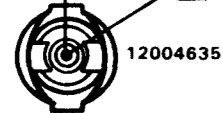

BRAKE
PRESSURE
WARNING
SWITCH

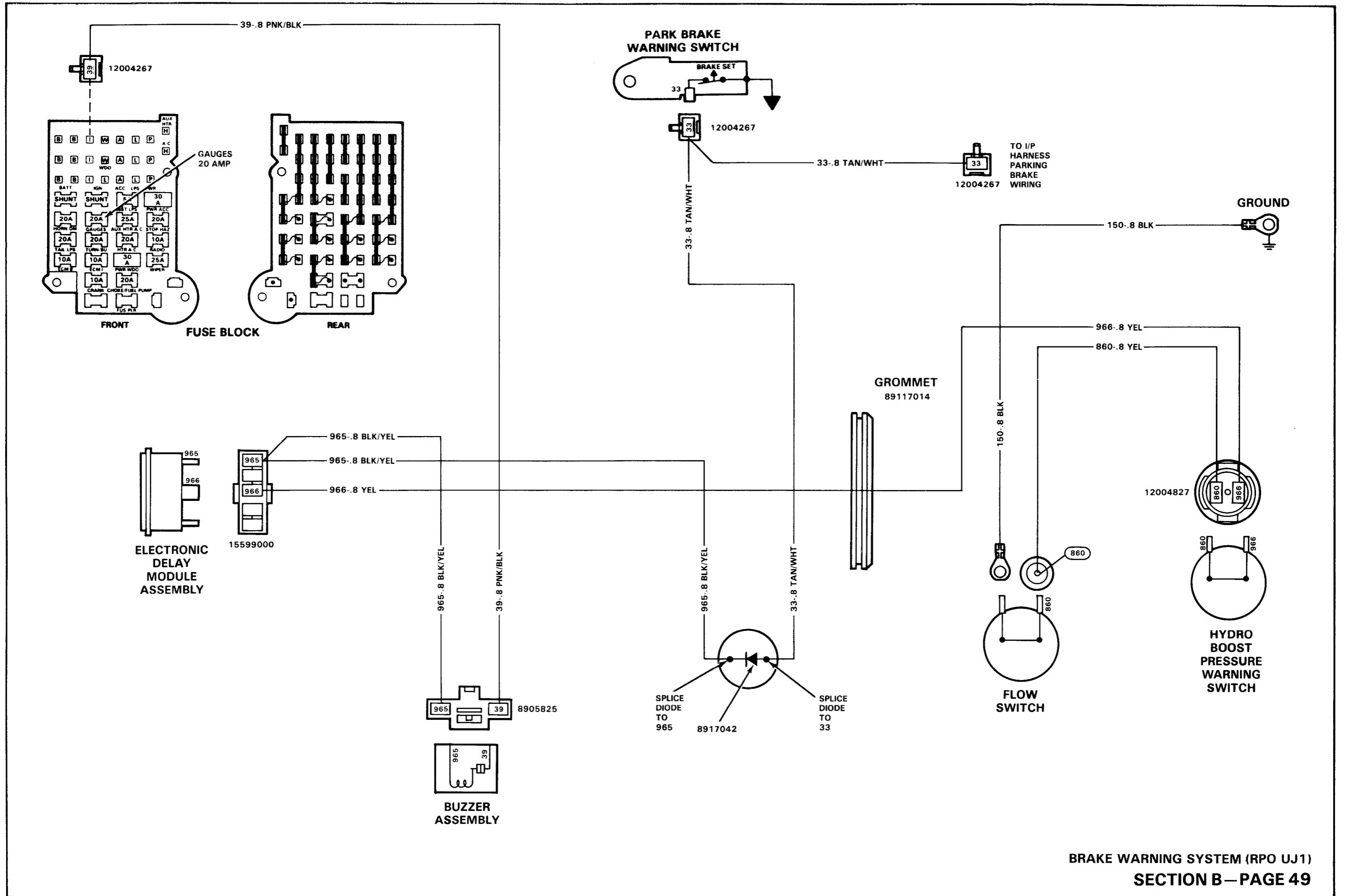

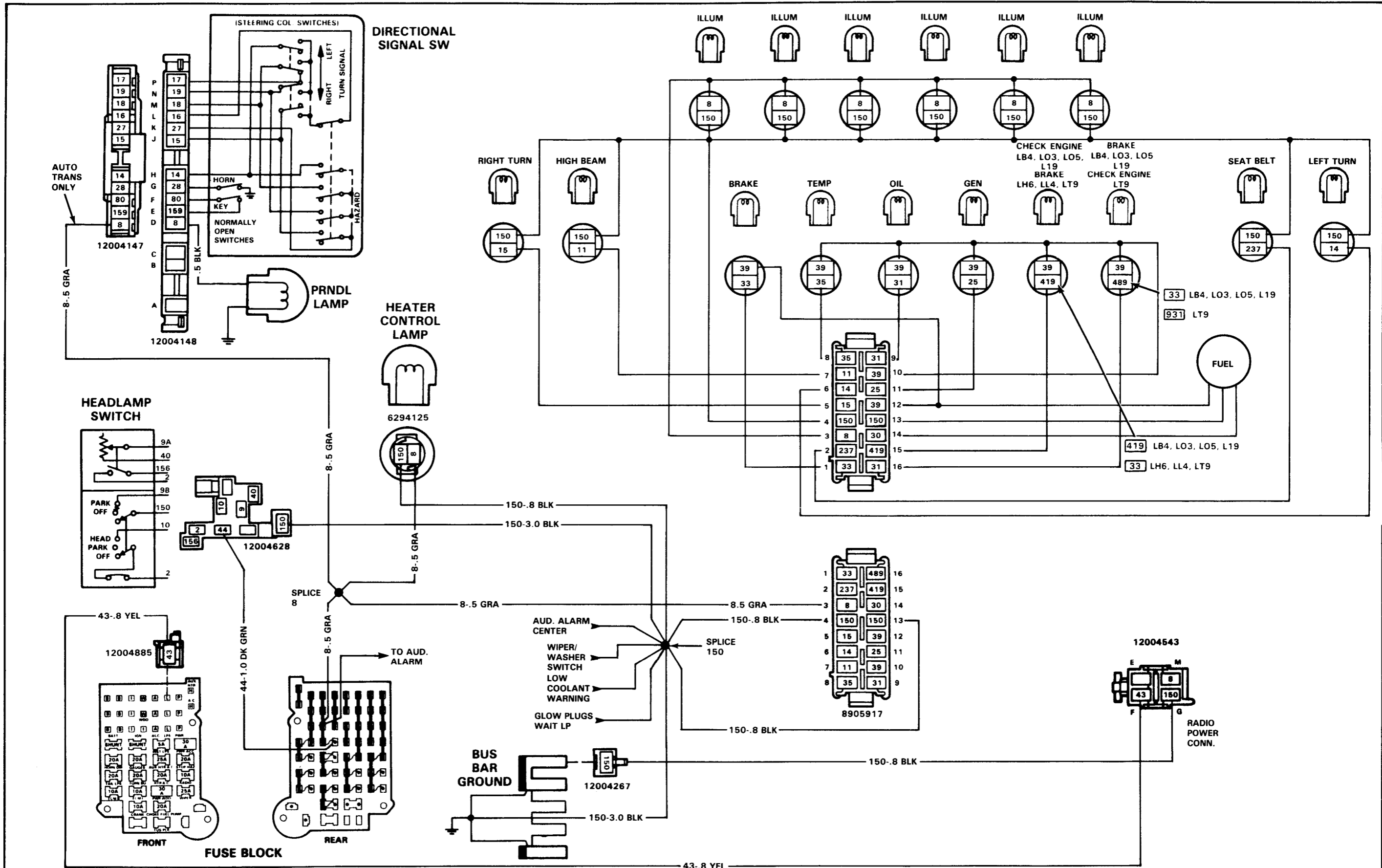

**INSTRUMENT PANEL LAMPS (TELLTALE)
SECTION B—PAGE 50**

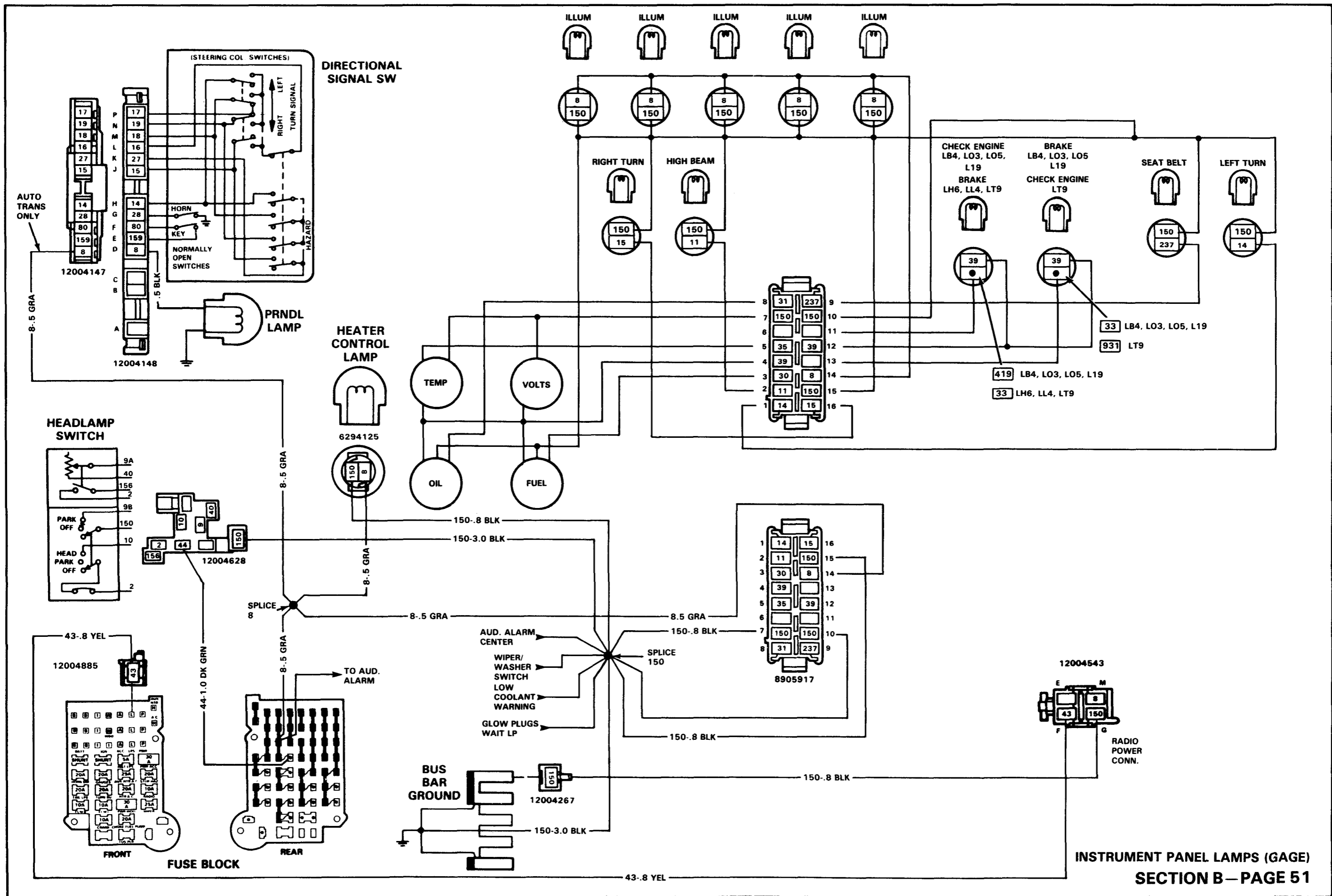

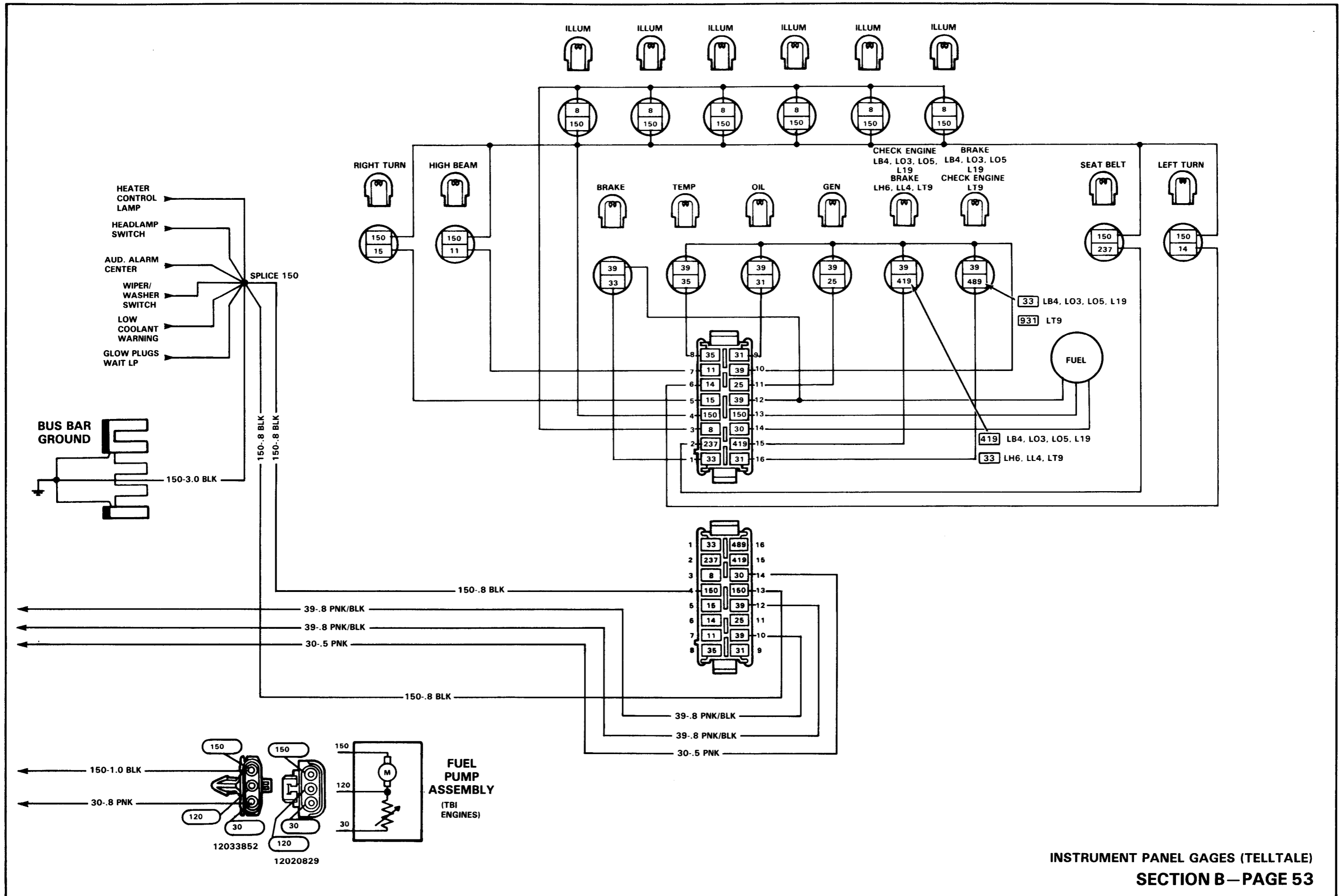

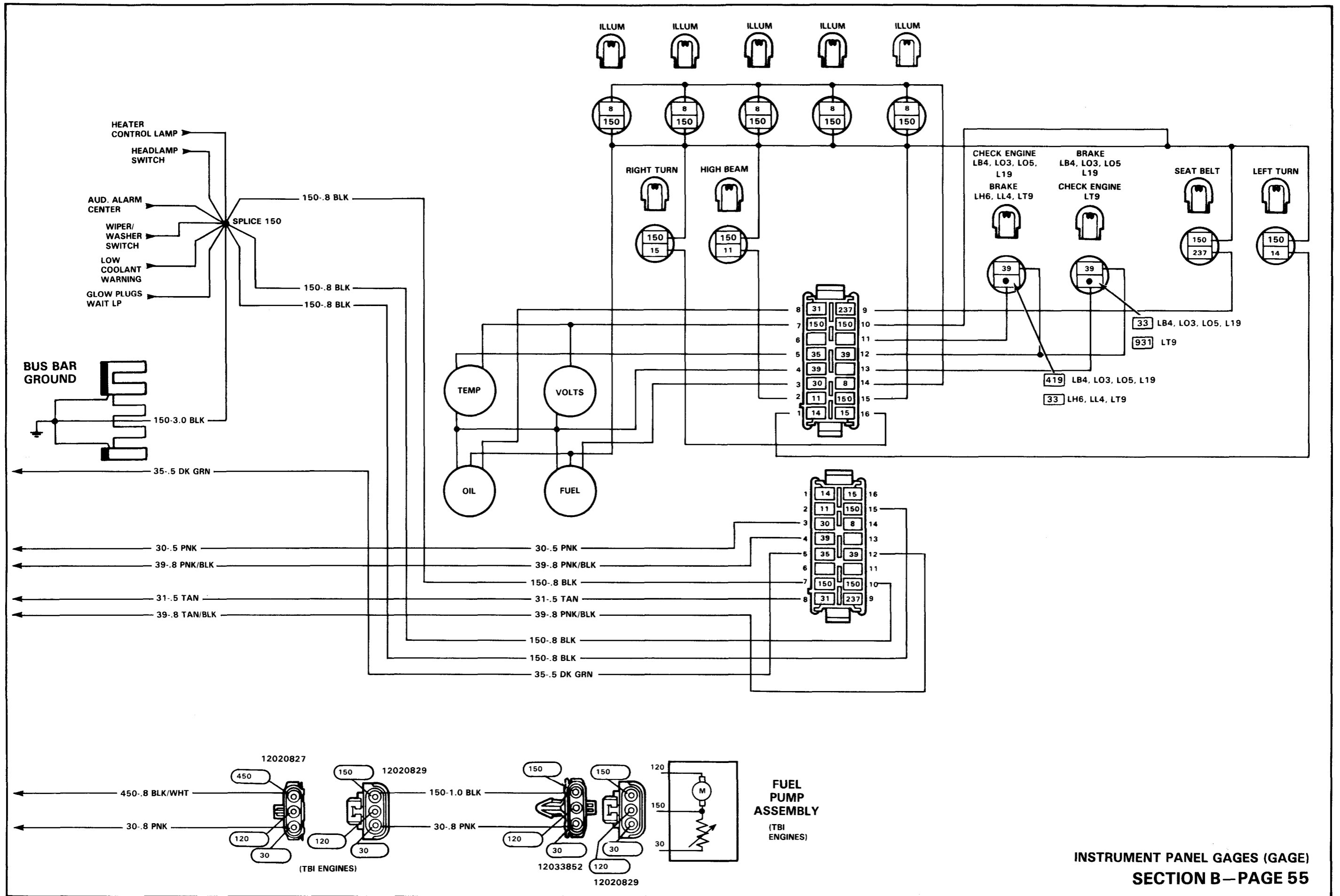

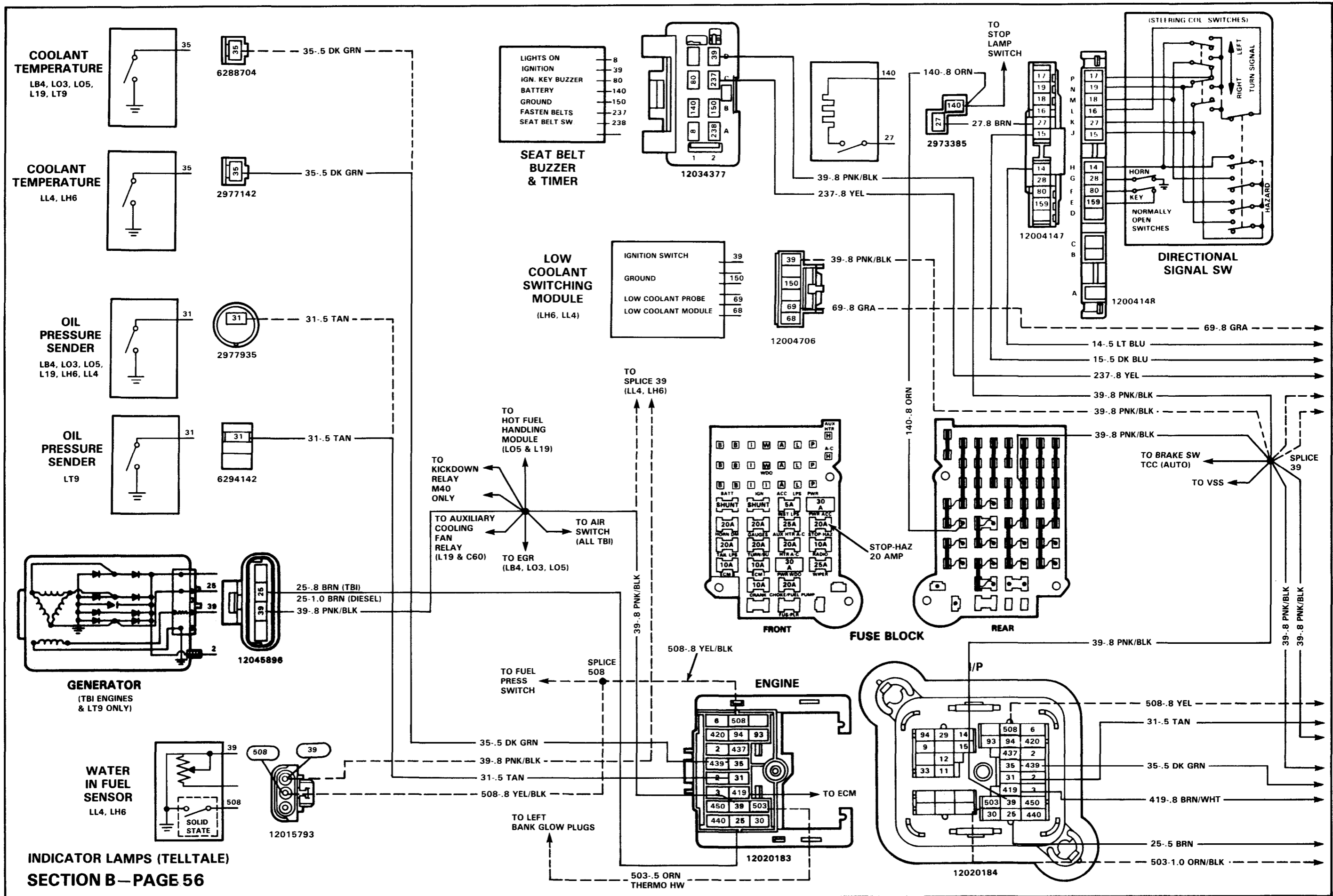

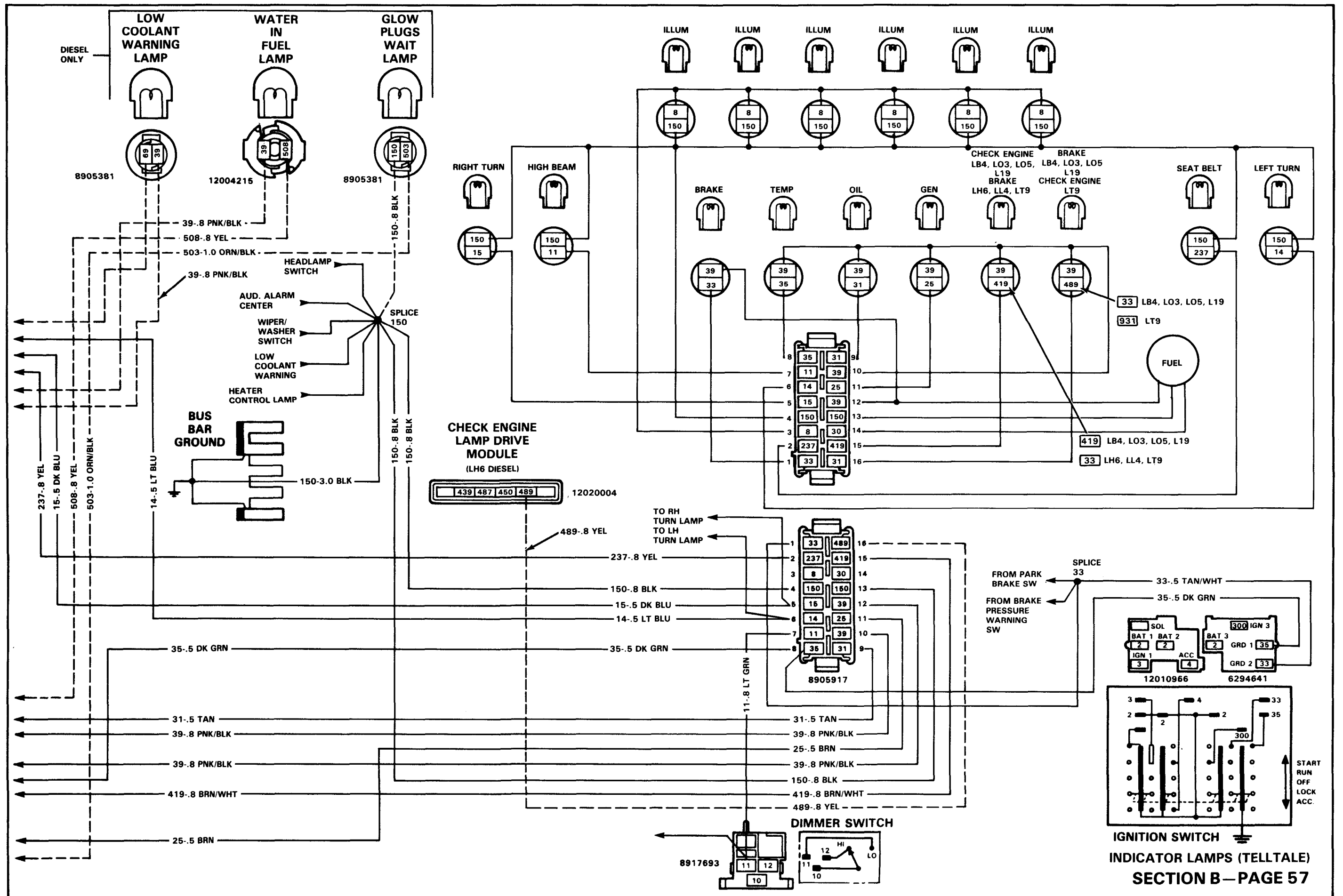

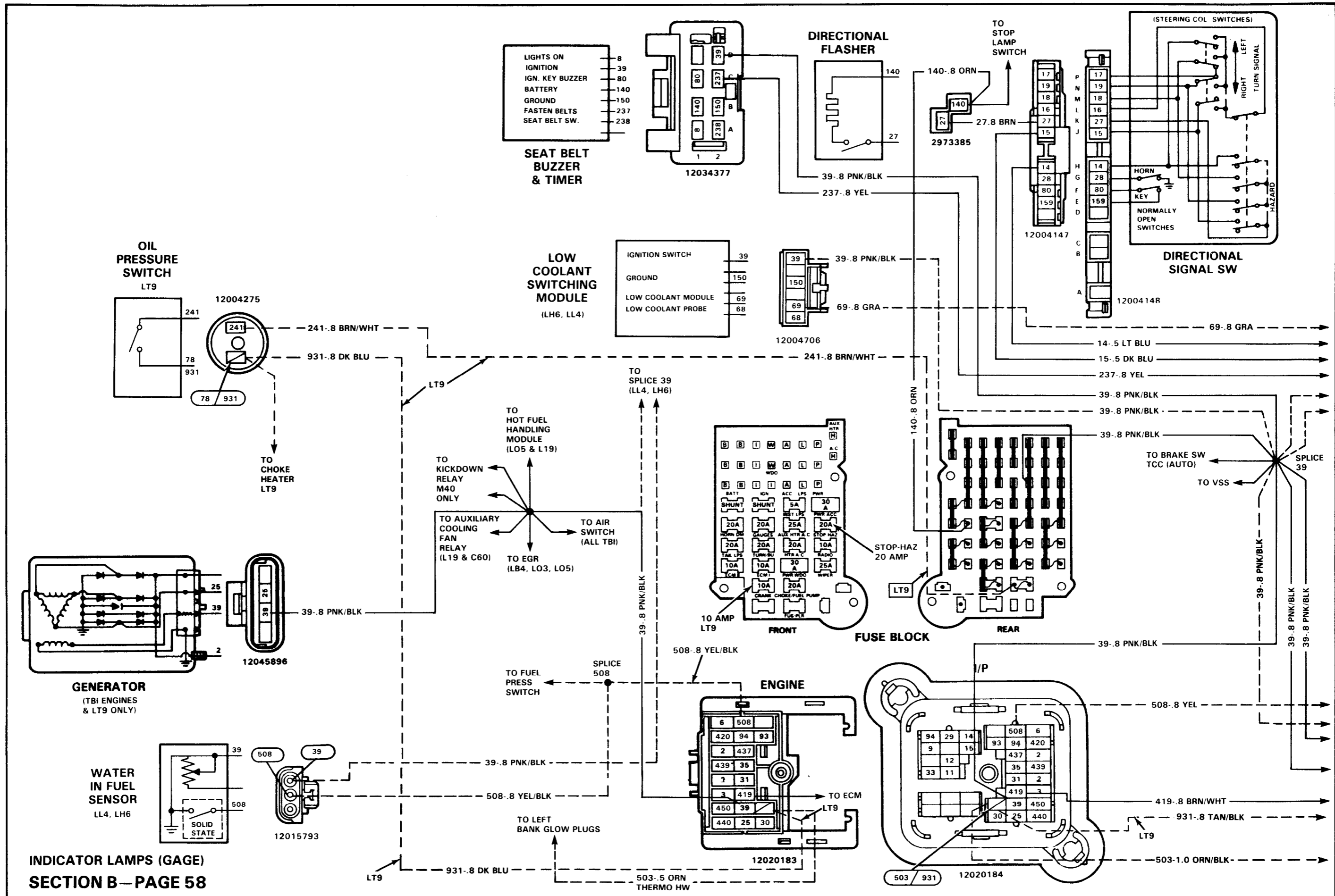

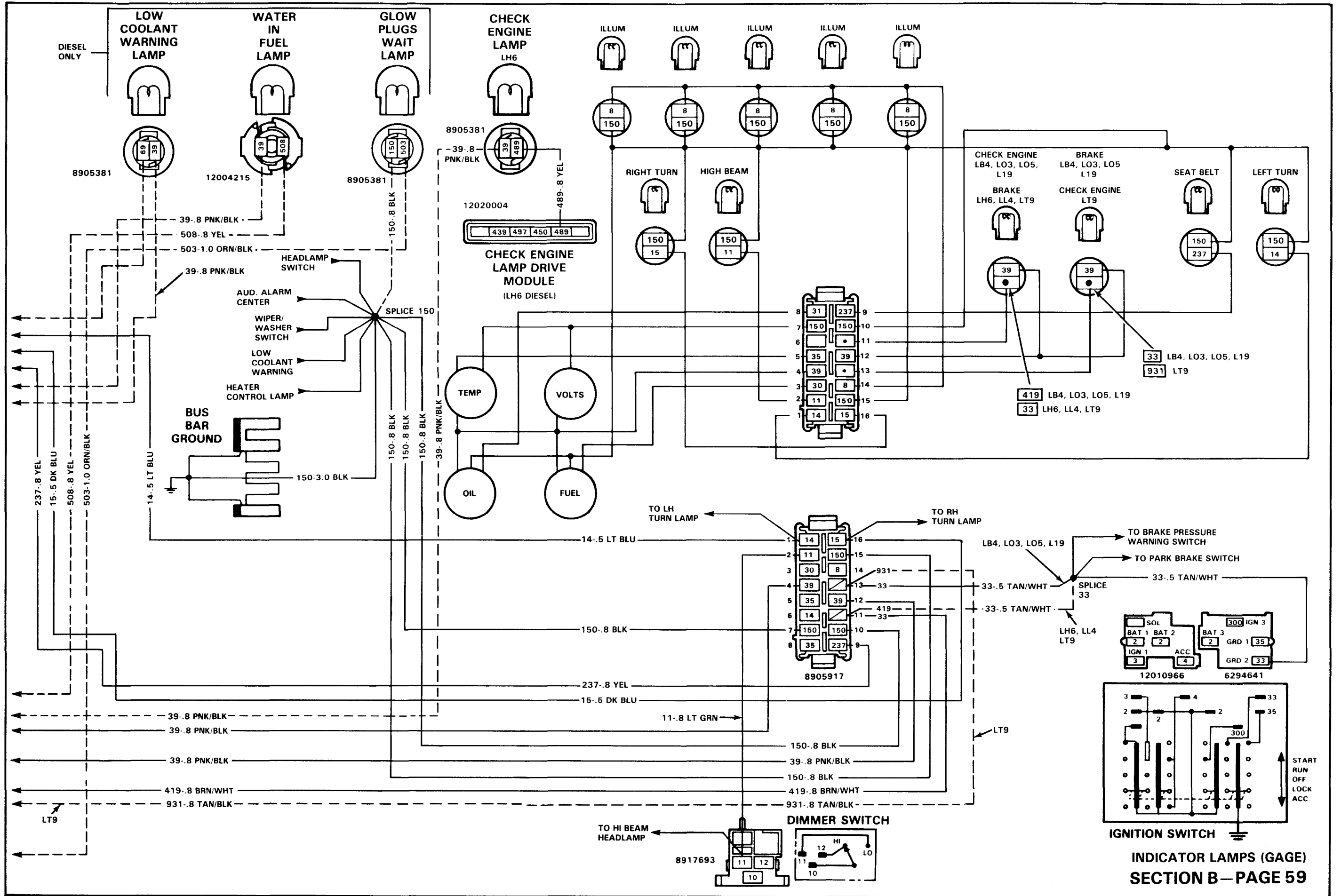

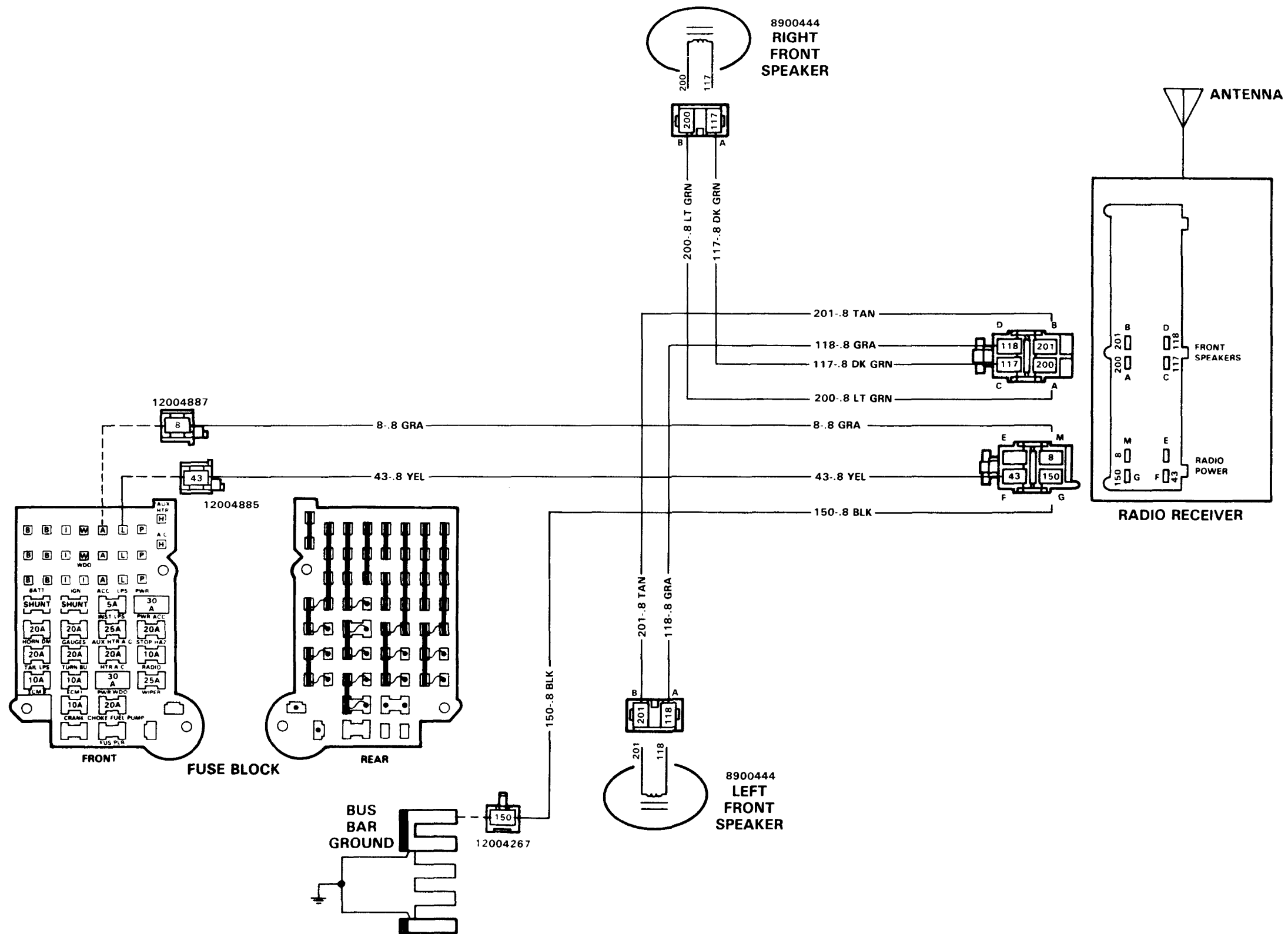

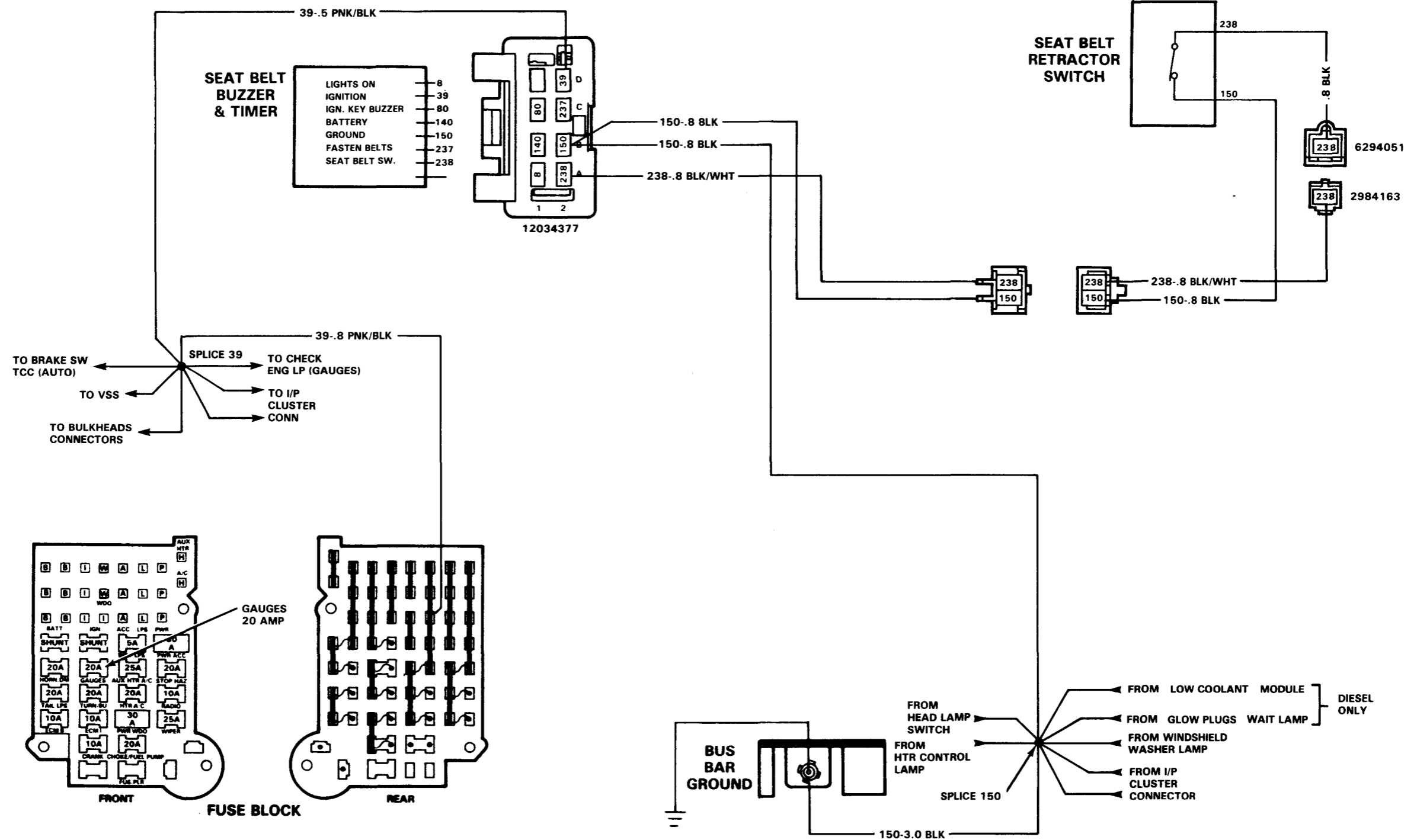

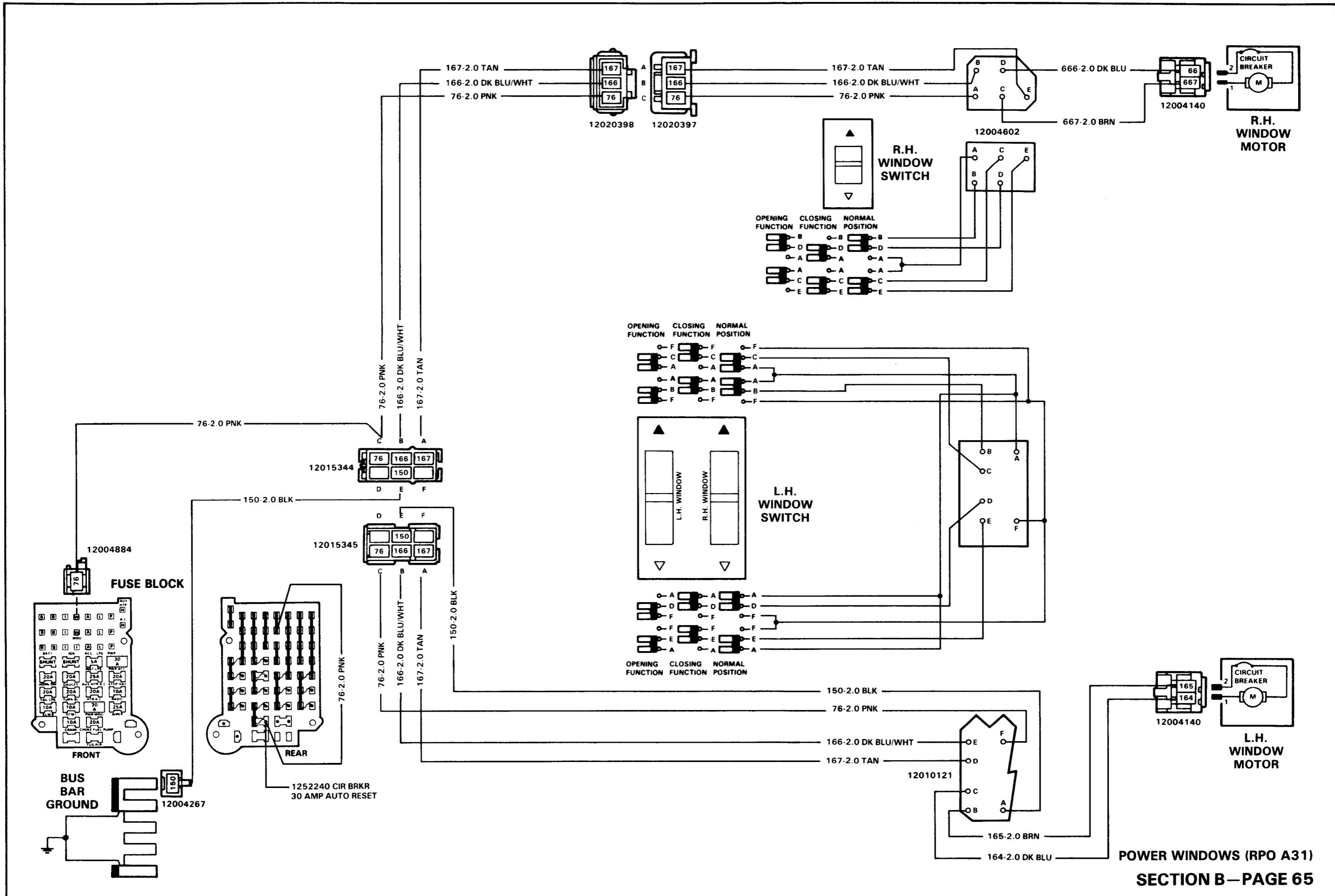

POWER WINDOWS (RPO A31)

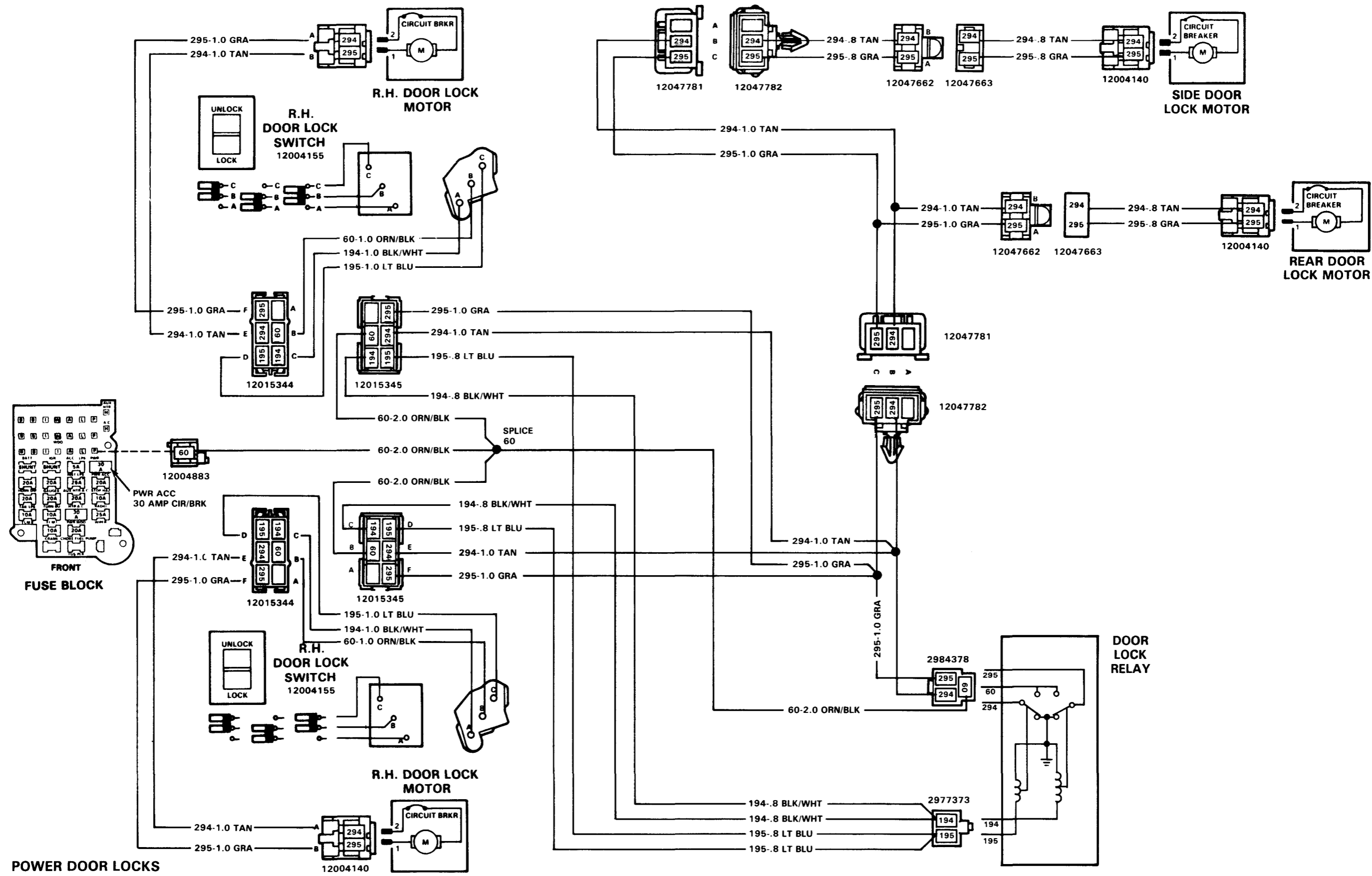

POWER DOOR LOCKS
WITH DELAY MODULE (RPO AU3)
SECTION B—PAGE 66

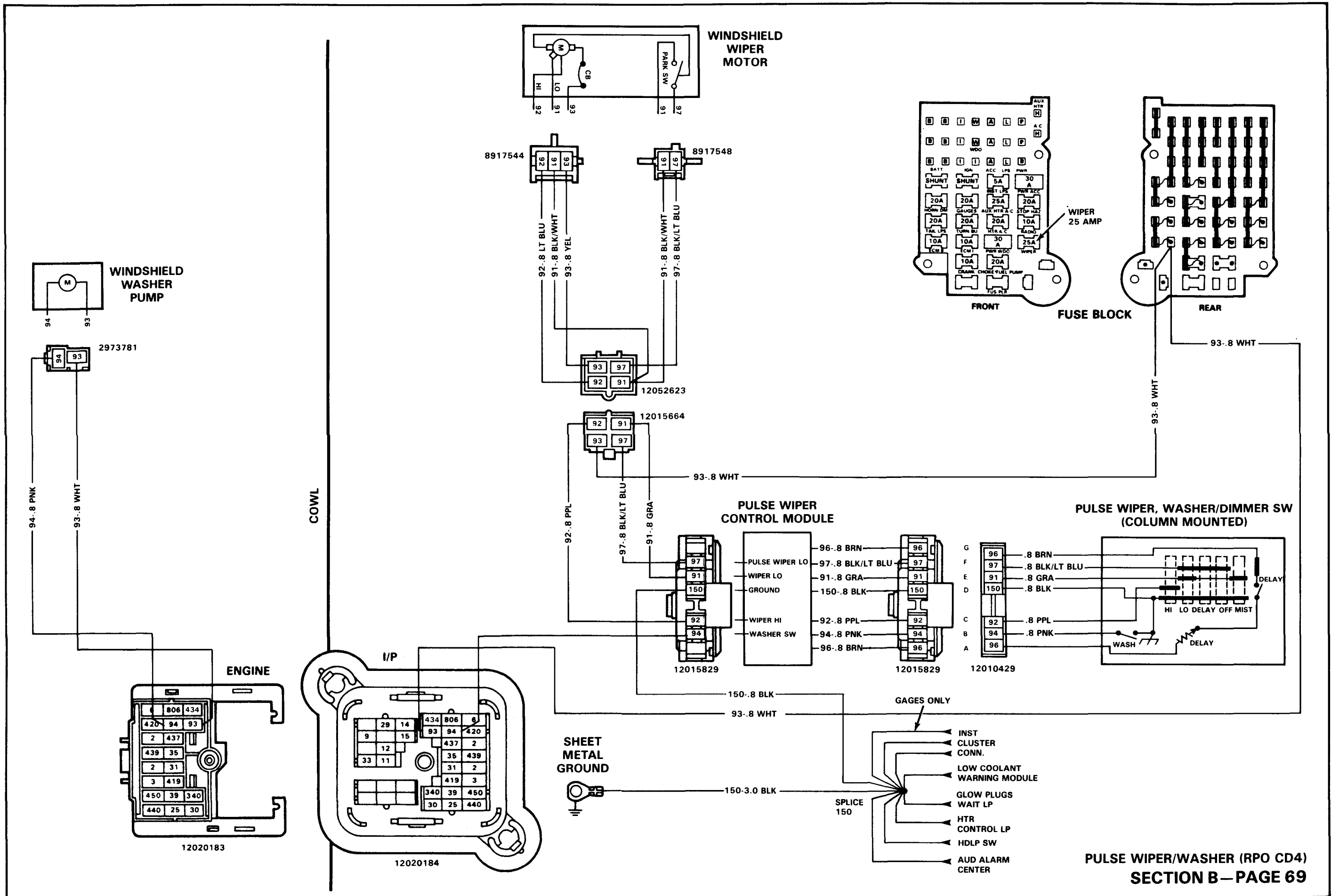

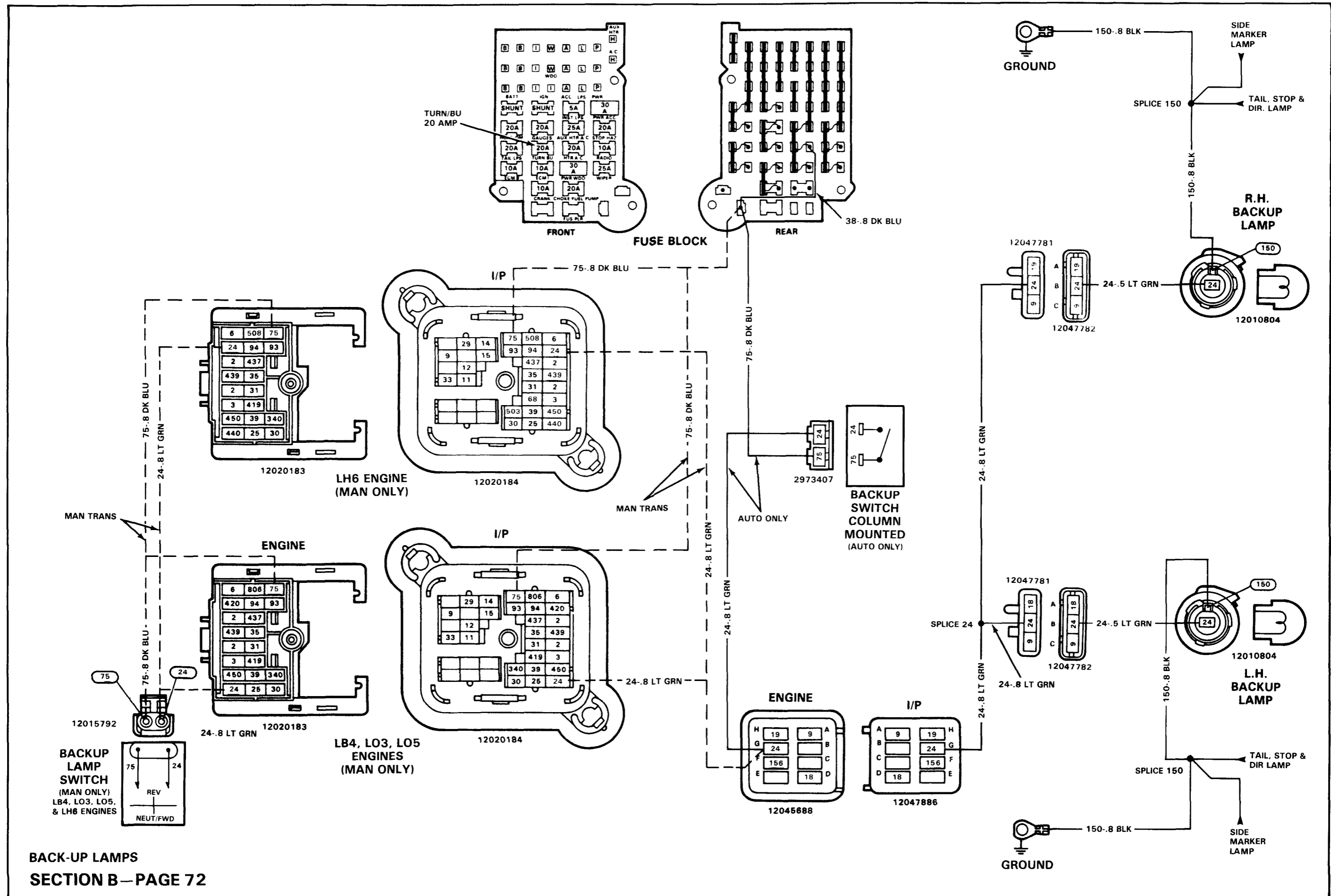

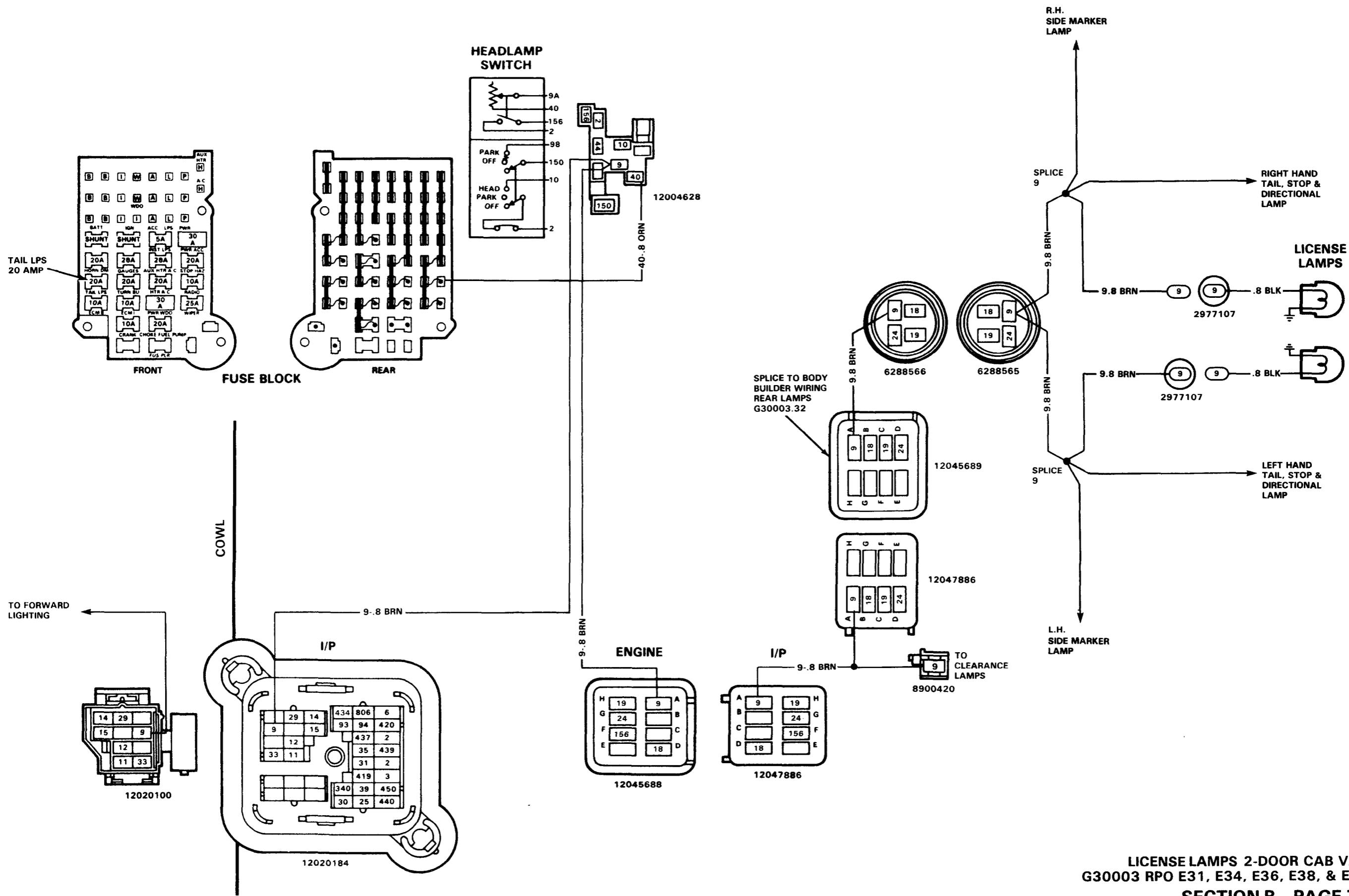

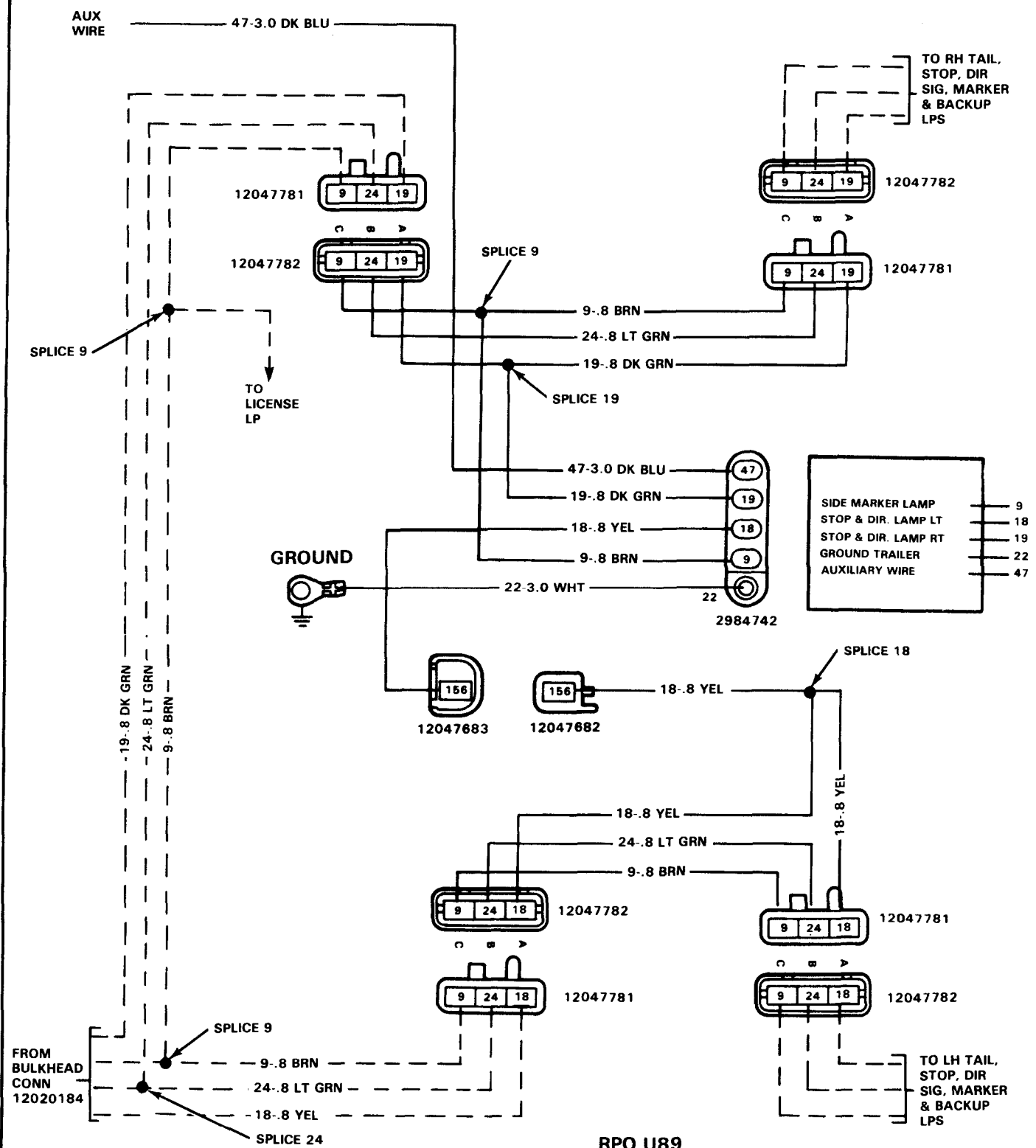

TRAILER WIRING
SECTION B—PAGE 78

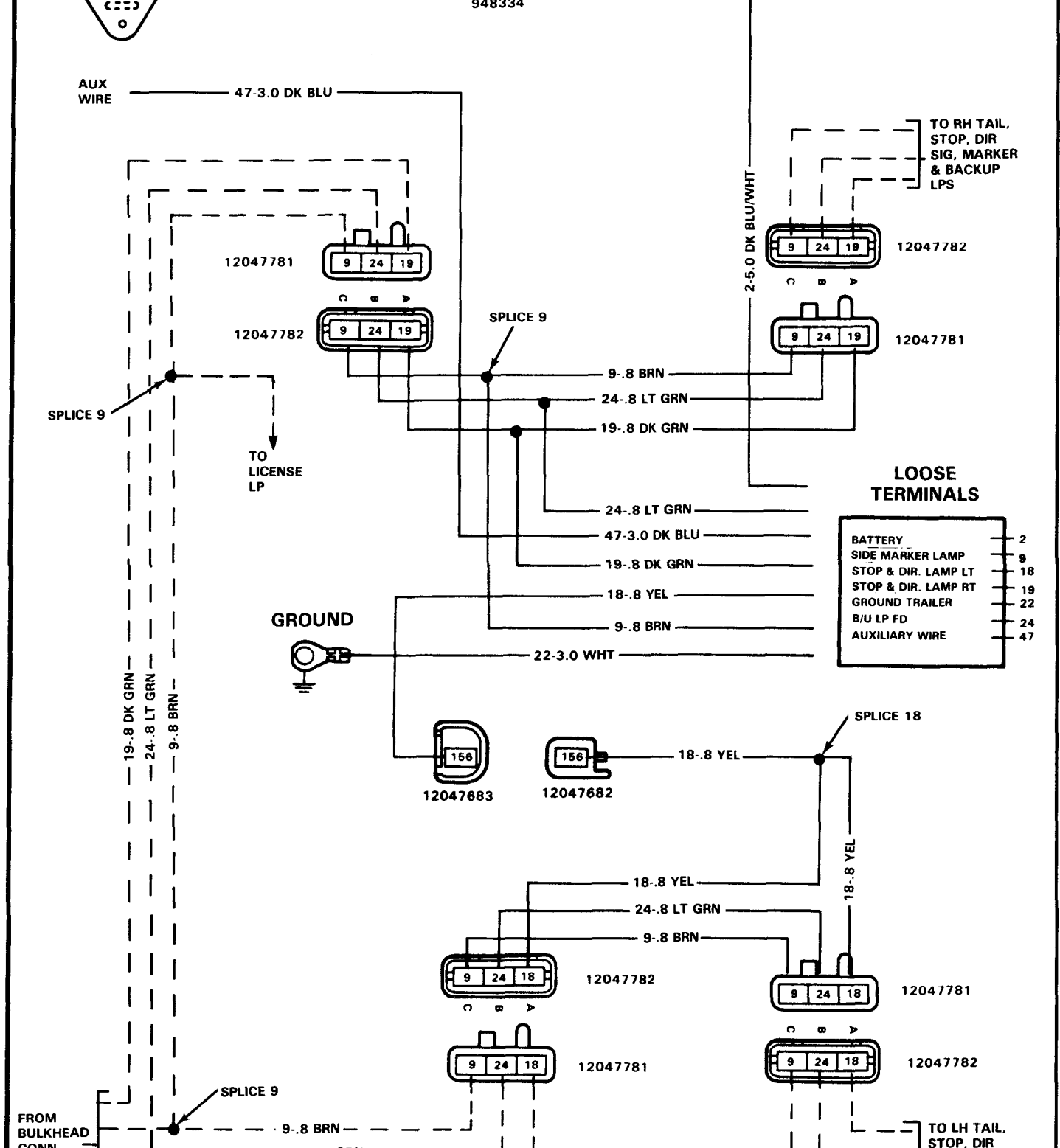

HEAVY DUTY RPO UY7

1988 S/T TRUCK

SECTION C

<u>PAGE</u>	<u>DESCRIPTION</u>	<u>PAGE</u>	<u>DESCRIPTION</u>
2	POWER DISTRIBUTION (LL2)	51	FOUR-WHEEL DRIVE INDICATOR
3	POWER DISTRIBUTION (LN8, LB4)	52	AIR CONDITIONING (4 CYL.)
4	FUSE BLOCK DETAIL	53	AIR CONDITIONING (6 CYL.) LL2, LB4
5	HEAD LAMPS & PARKING LAMPS	54	HEATER
6	MARKER LAMPS	55	BRAKE WARNING SYSTEM
8	HAZARD LAMPS	56	INSTRUMENT PANEL LAMPS (TELLTALE VERSION)
12	DIRECTIONAL LAMPS	57	INSTRUMENT PANEL LAMPS (GAGE VERSION)
16	HORNS	58	INSTRUMENT PANEL GAGES (TELLTALE VERSION)
17	START (4 CYL.)	60	INSTRUMENT PANEL GAGES (GAGE VERSION)
18	START (6 CYL.) LL2	62	INDICATOR LAMPS (TELLTALE VERSION)
19	START (6 CYL.) LB4	64	INDICATOR LAMPS (GAGE VERSION)
20	IGNITION (4 CYL.)	66	DOME LAMPS
22	IGNITION (6 CYL.) LL2	69	INSTRUMENT PANEL COURTESY LAMPS (03-53 MODELS)
24	IGNITION (6 CYL.) LB4	70	RADIO EQUIPMENT (STEREO) (UM2, UM3, U58)
26	THROTTLE BODY INJECTION (4 CYL.)	71	RADIO EQUIPMENT
27	THROTTLE BODY INJECTION (6 CYL.)	72	POWER WINDOWS (A31)
28	FUEL CONTROL & IDLE AIR CONTROL (4 CYL.)	73	POWER DOOR LOCKS (AU3)
29	FUEL CONTROL & IDLE AIR CONTROL (6 CYL.) LL2	74	I/P COMPARTMENT BOX LAMP (TR9)
30	FUEL CONTROL & IDLE AIR CONTROL (6 CYL.) LB4	75	SEAT BELT WARNING BUZZER
31	FUEL SENSOR	76	VANITY MIRROR (D64)
32	ELECTRONIC CONTROL MODULE (ECM)—INPUTS (4 CYL.)	77	WIPER/WASHER
34	ELECTRONIC CONTROL MODULE (ECM)—OUTPUTS (4 CYL.)	78	CRUISE CONTROL (K34)
37	ECM CHART (4 CYL.)	79	REAR DEFOGGER (C49)
38	ELECTRONIC CONTROL MODULE (ECM)—INPUTS (6 CYL.) LL2	80	LIFTGATE RELEASE (AU6)
40	ELECTRONIC CONTROL MODULE (ECM)—OUTPUTS (6 CYL.) LL2	81	CARGO LAMP (UF2)
43	ECM CHART (6 CYL.) LL2	82	BACK-UP LAMPS
44	ELECTRONIC CONTROL MODULE (ECM)—INPUTS (6 CYL.) LB4	84	TAIL LAMPS
46	ELECTRONIC CONTROL MODULE (ECM)—OUTPUTS (6 CYL.) LB4	86	LICENSE LAMP(S)
49	ECM CHART (6 CYL.) LB4	88	TRAILER WIRING
50	TRANSMISSION CONVERTER CLUTCH DETENT SOLENOID	89	HEAVY DUTY TRAILER WIRING (UY7)

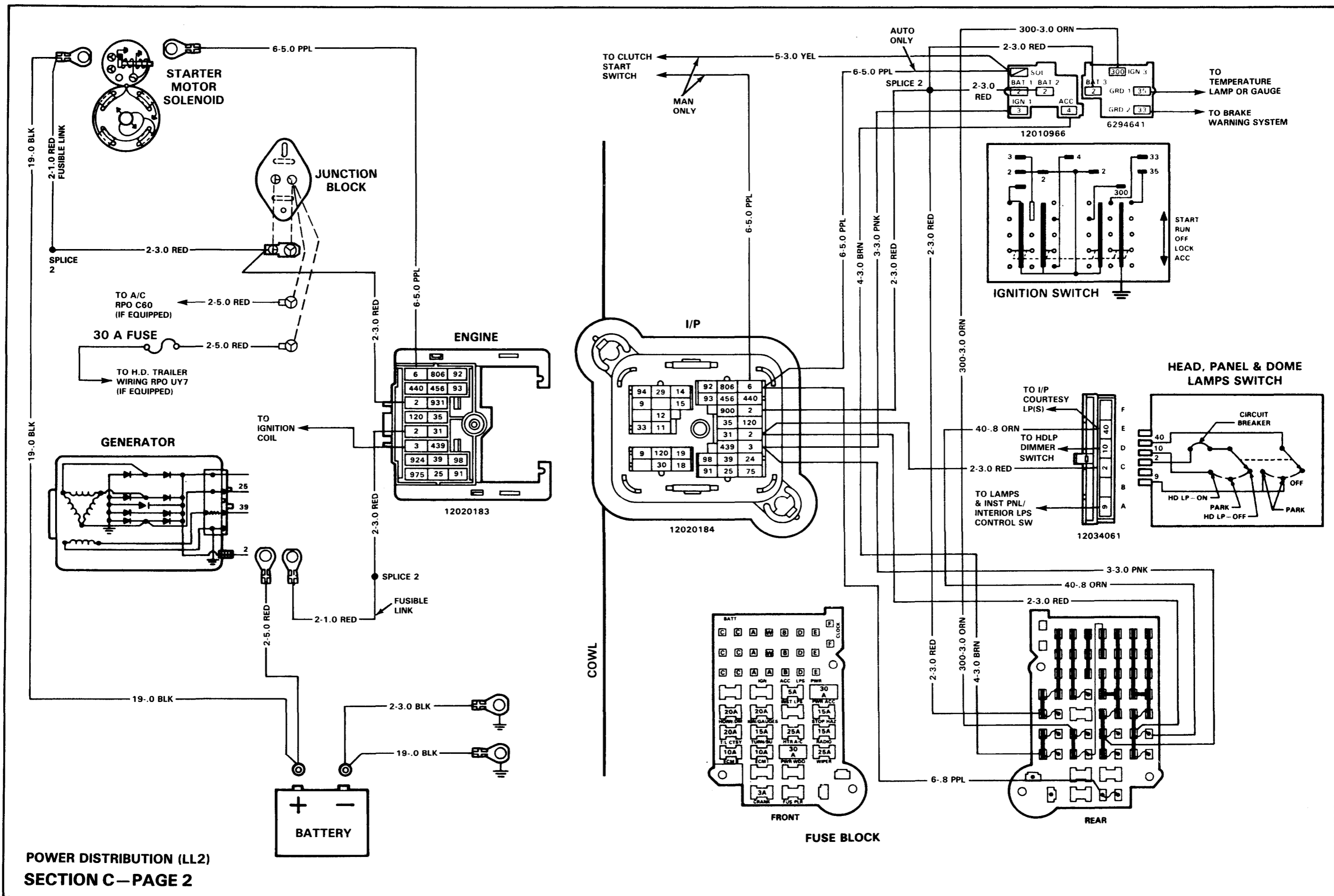

POWER DISTRIBUTION (LL2)
SECTION C - PAGE 2

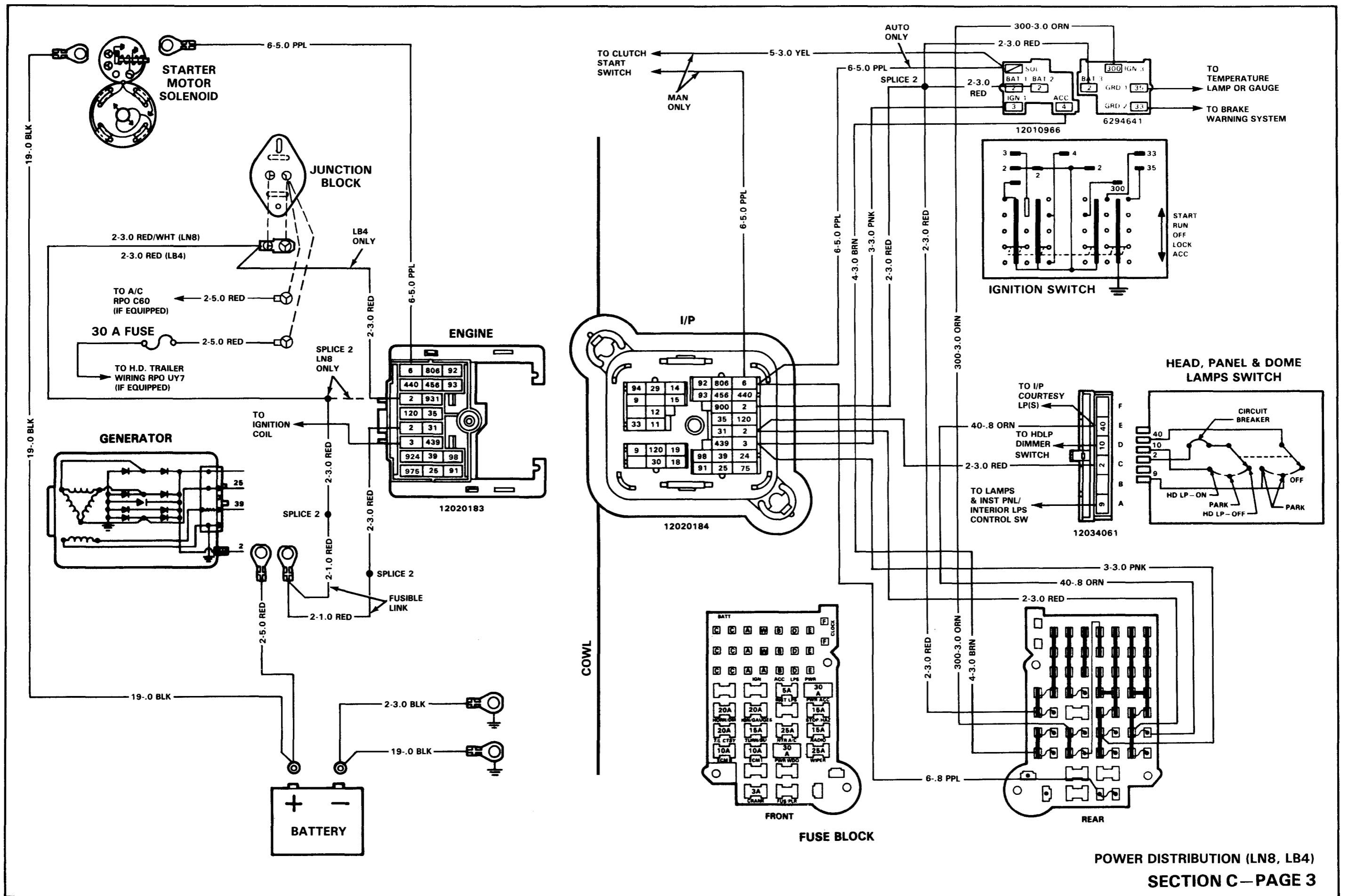

POWER DISTRIBUTION (LN8, LB4)
SECTION C—PAGE 3

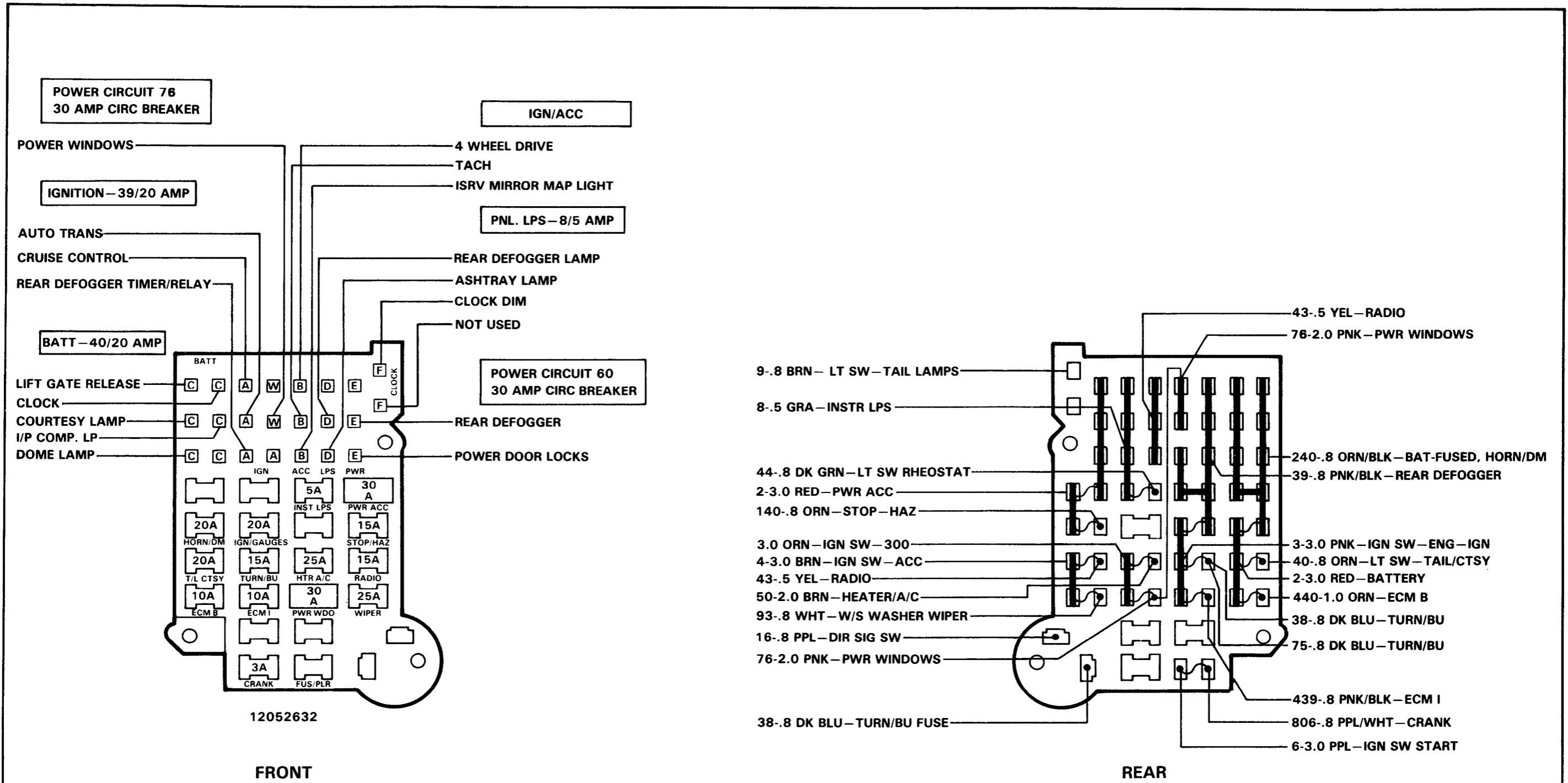

12052632

FRONT

REAR

	COLOR	MALE CONN	MULT CONN
A	NAT	12004888	12004892
B	BRN	12004887	12004893
C	BLK	12004886	12004890
D	GRN	12004885	12004962
E	RED	12004883	12004889
W	BLU	12004884	NOT USABLE
F	DK GRA		

FUSES	AMP	COLOR
12004005	5	TAN
12004007	10	RED
12004008	15	LT BLU
12004009	20	YEL
12004010	25	WHT
12004003	3	VIOLET
12004006	7.5	BROWN
12004011	30	LT GRN

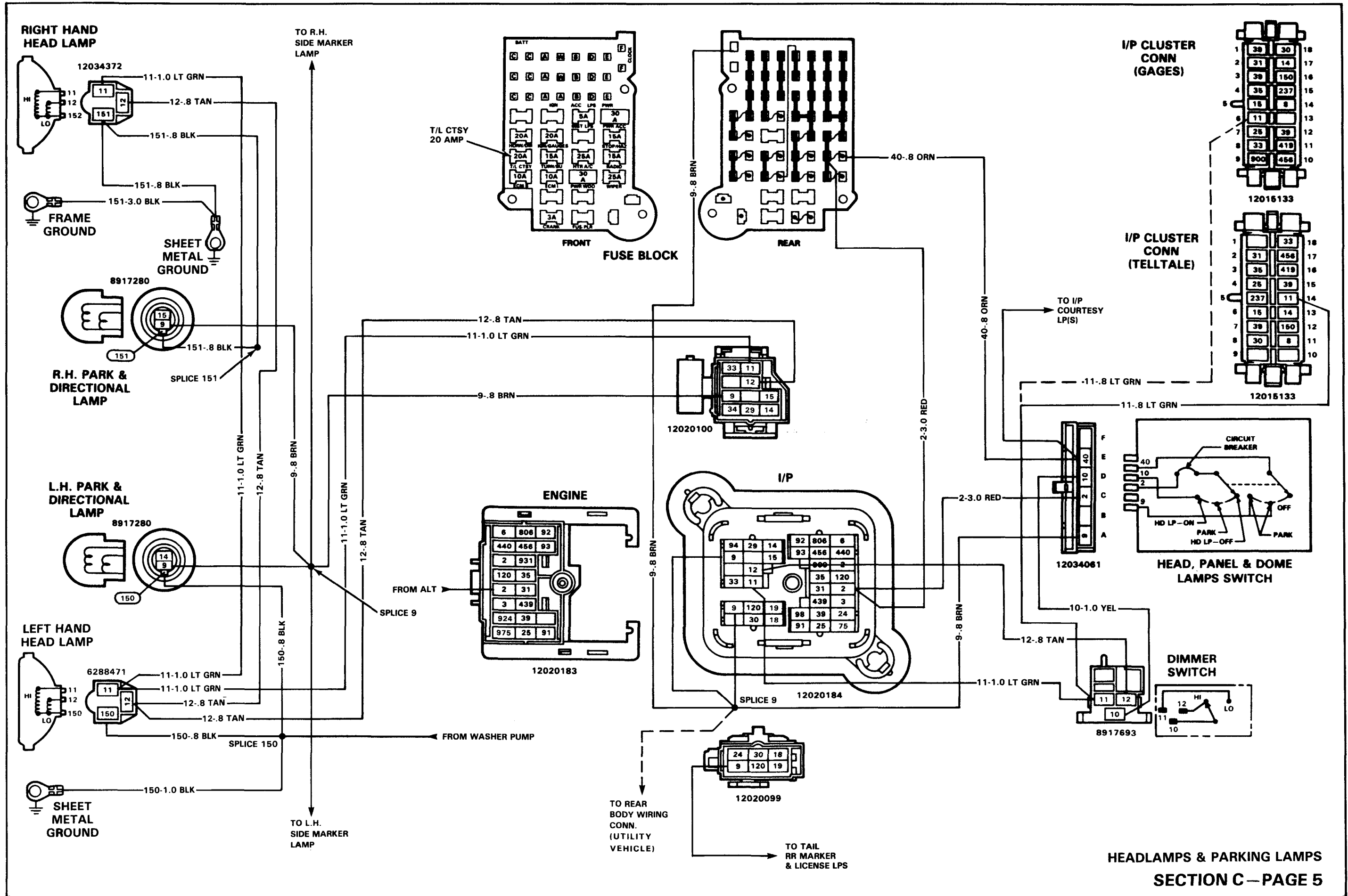

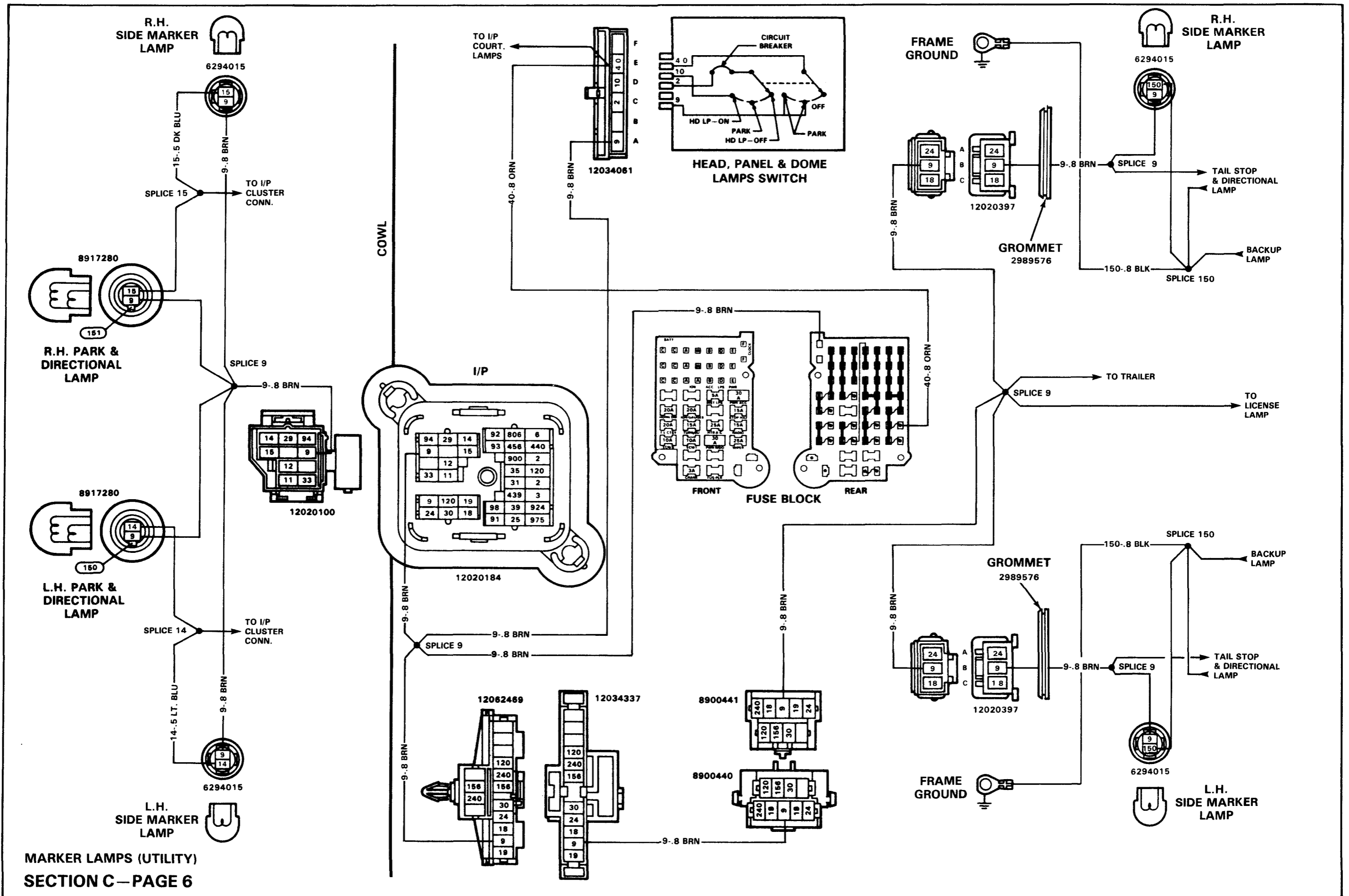

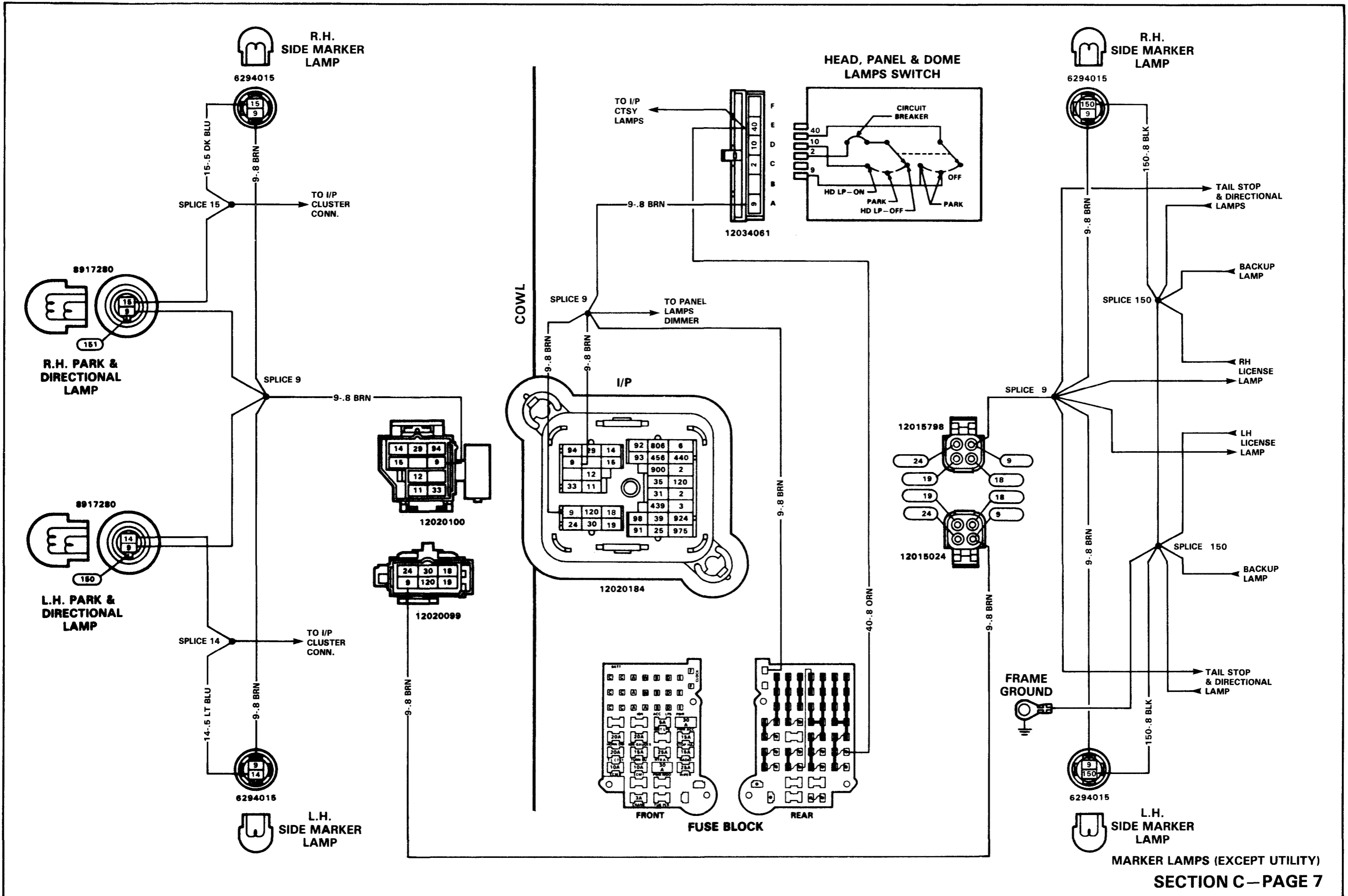

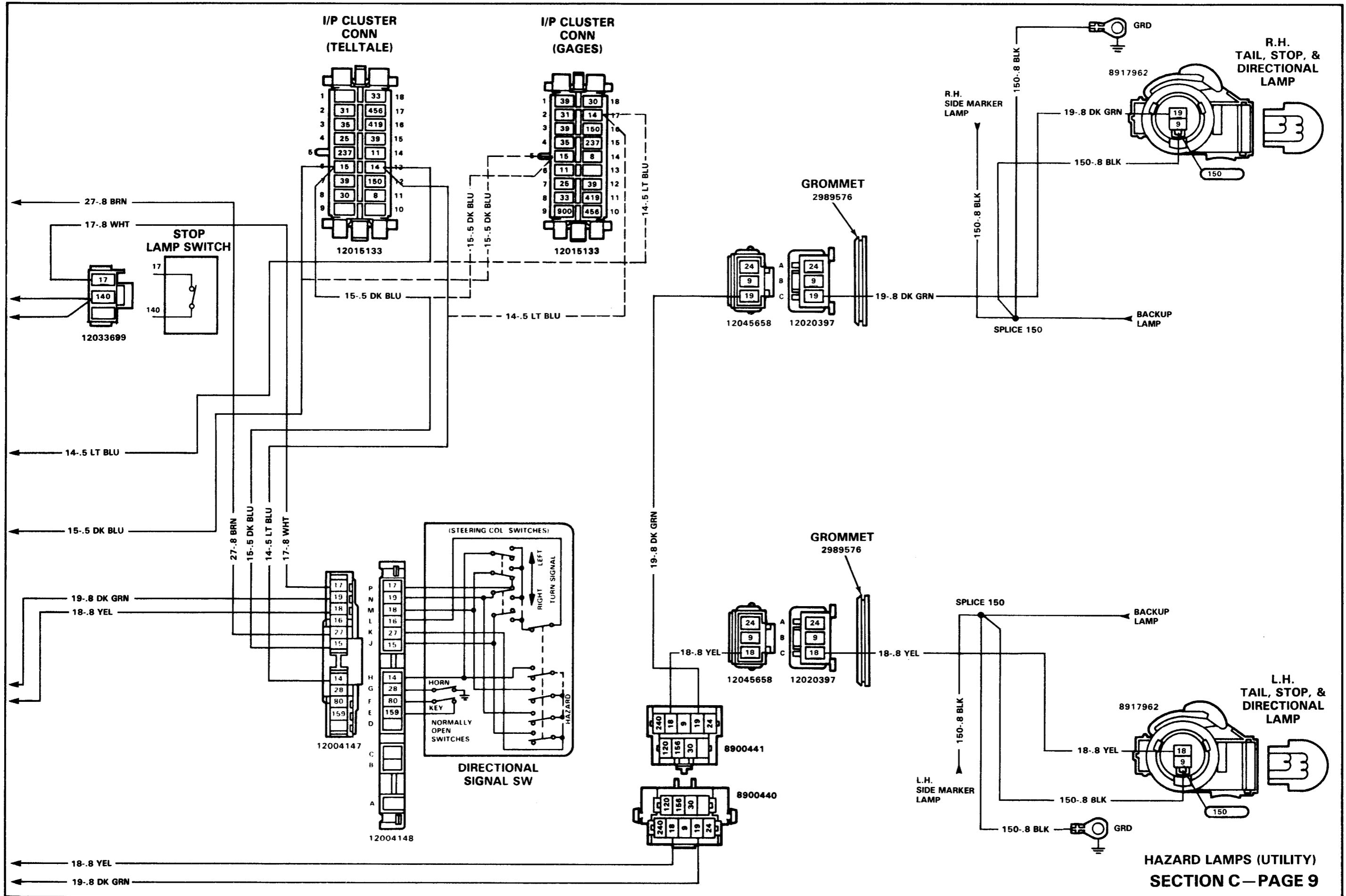

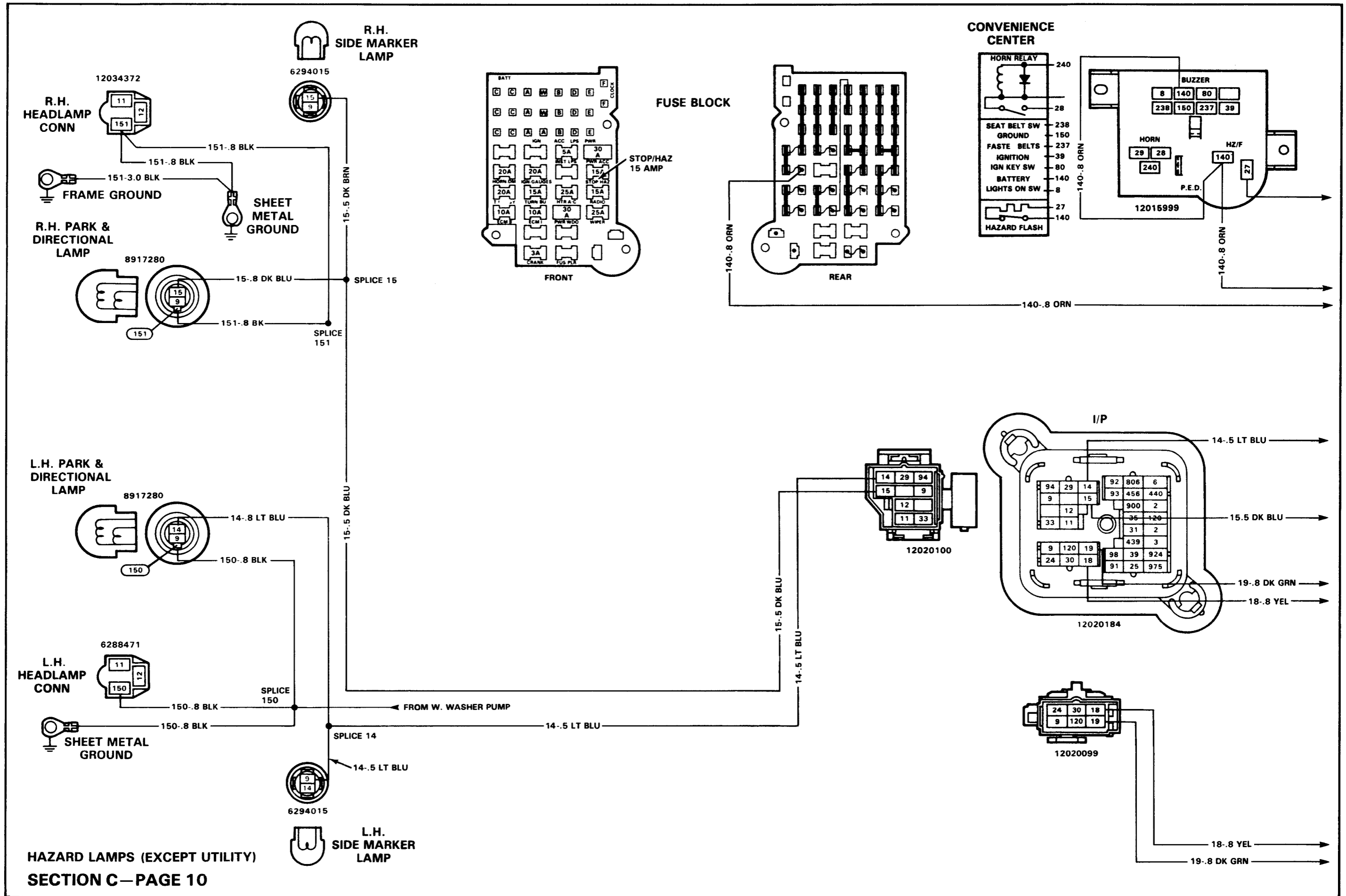

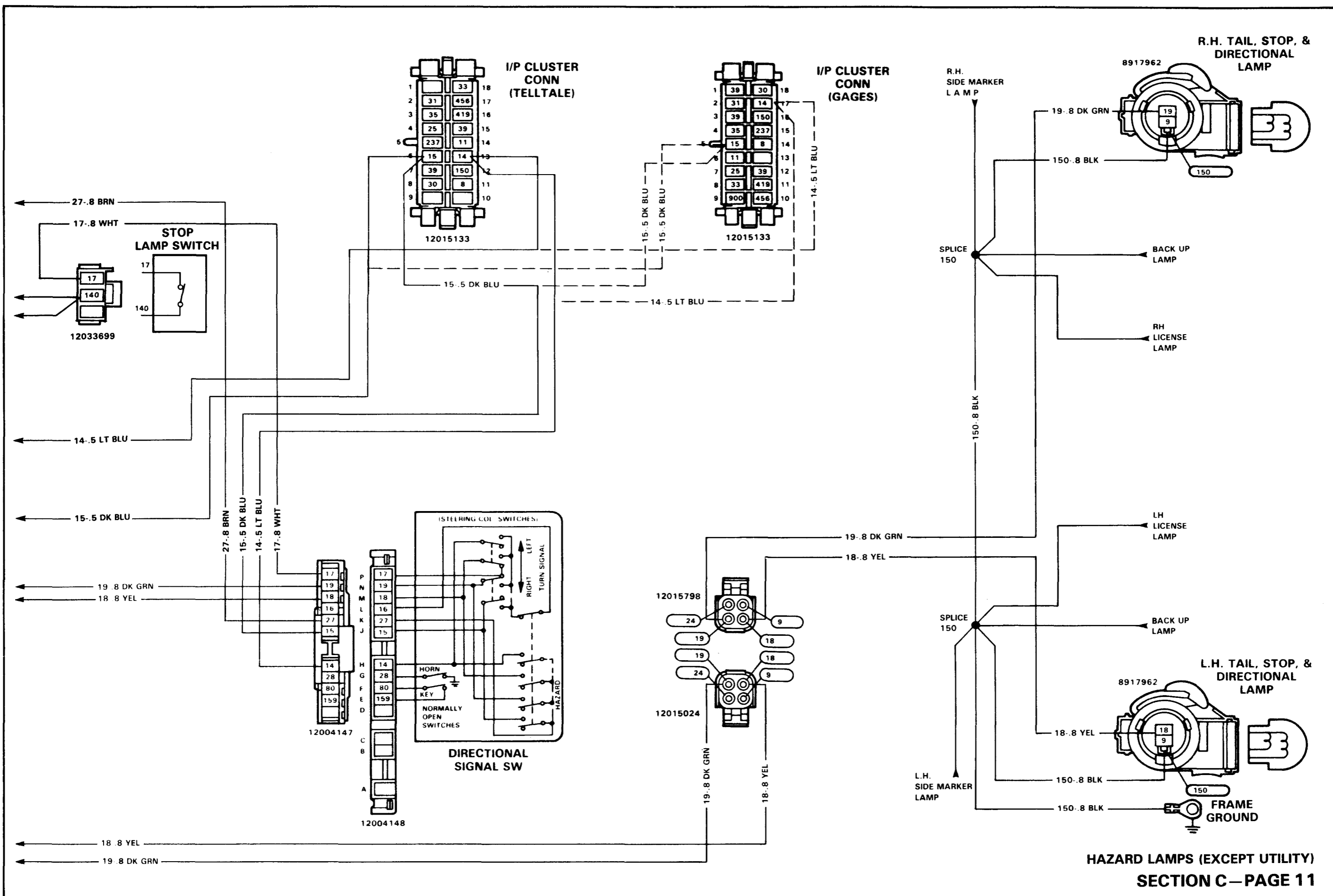

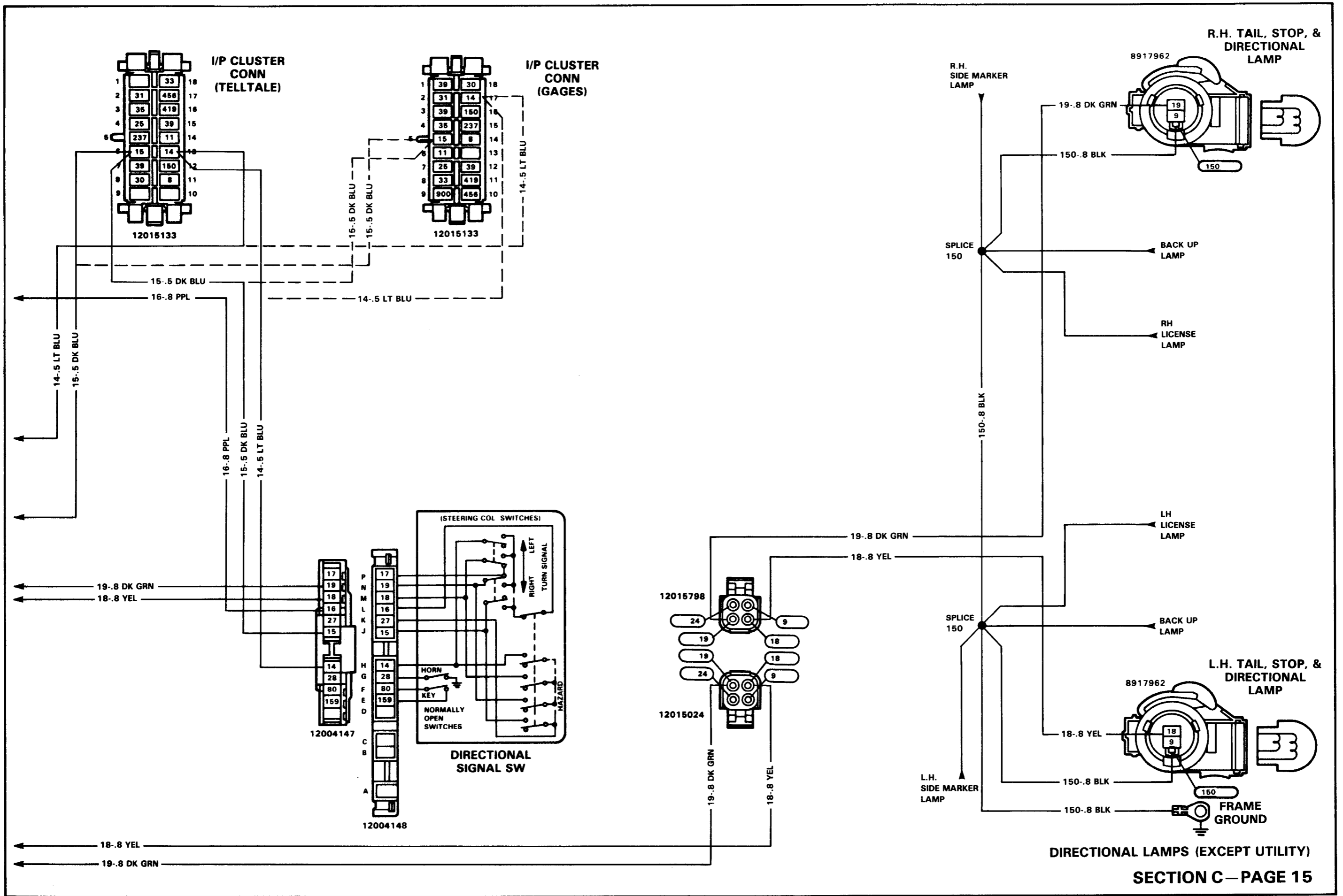

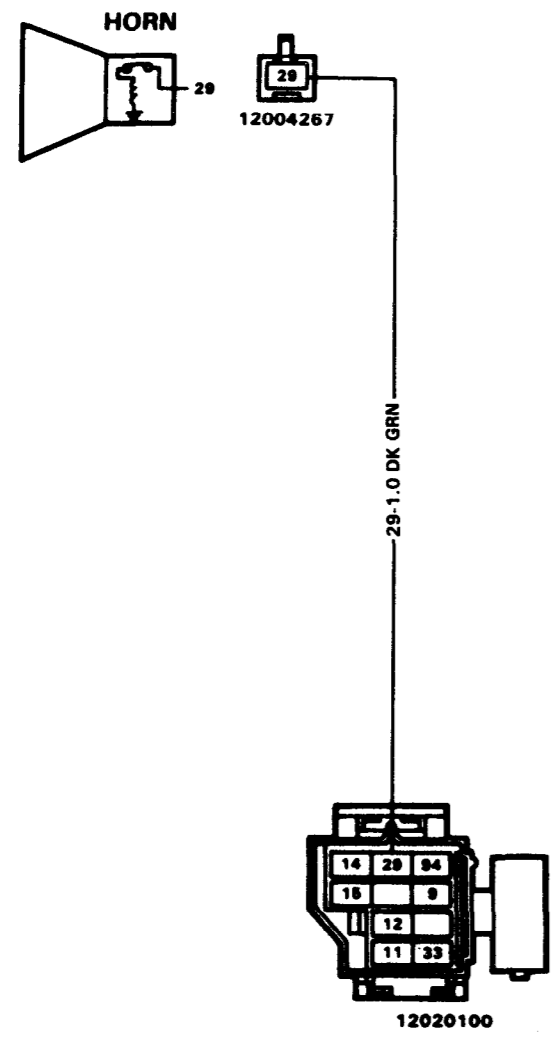

CONVENIENCE CENTER

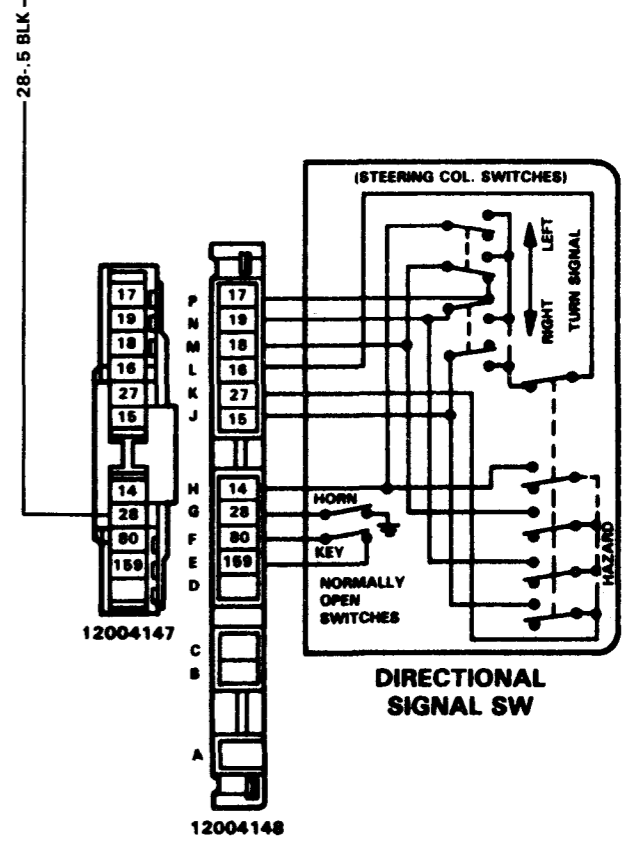
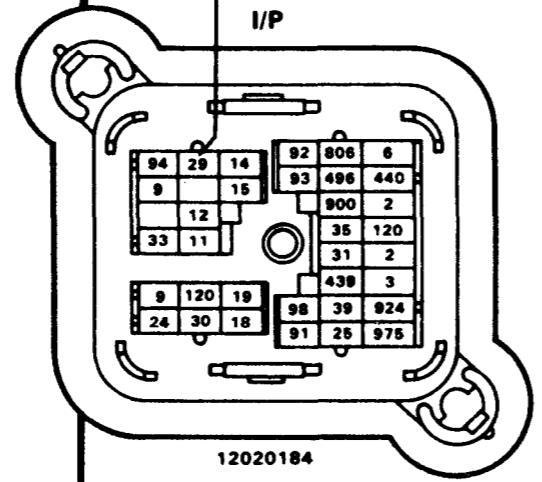
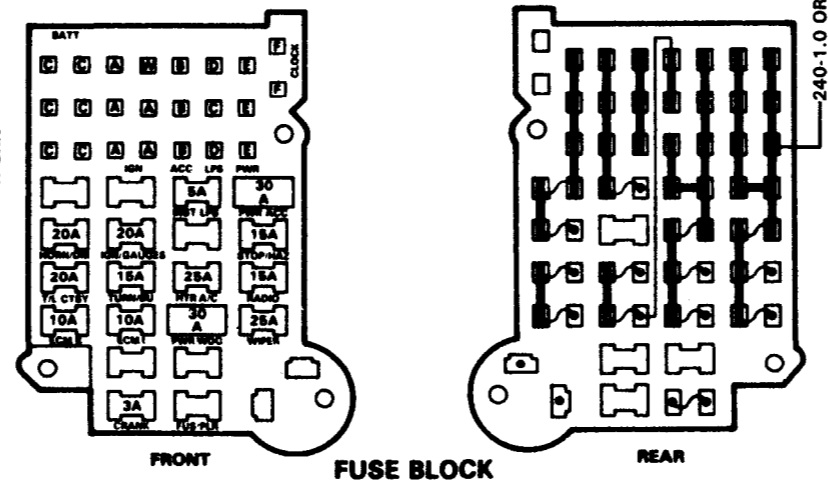
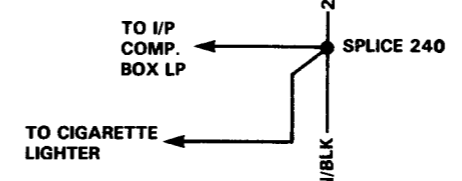
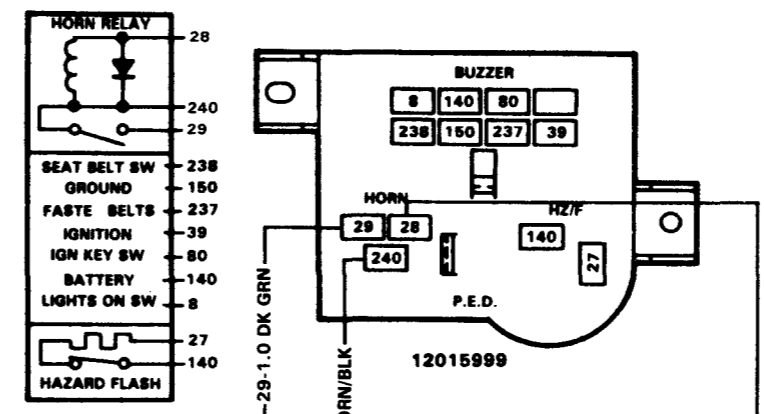

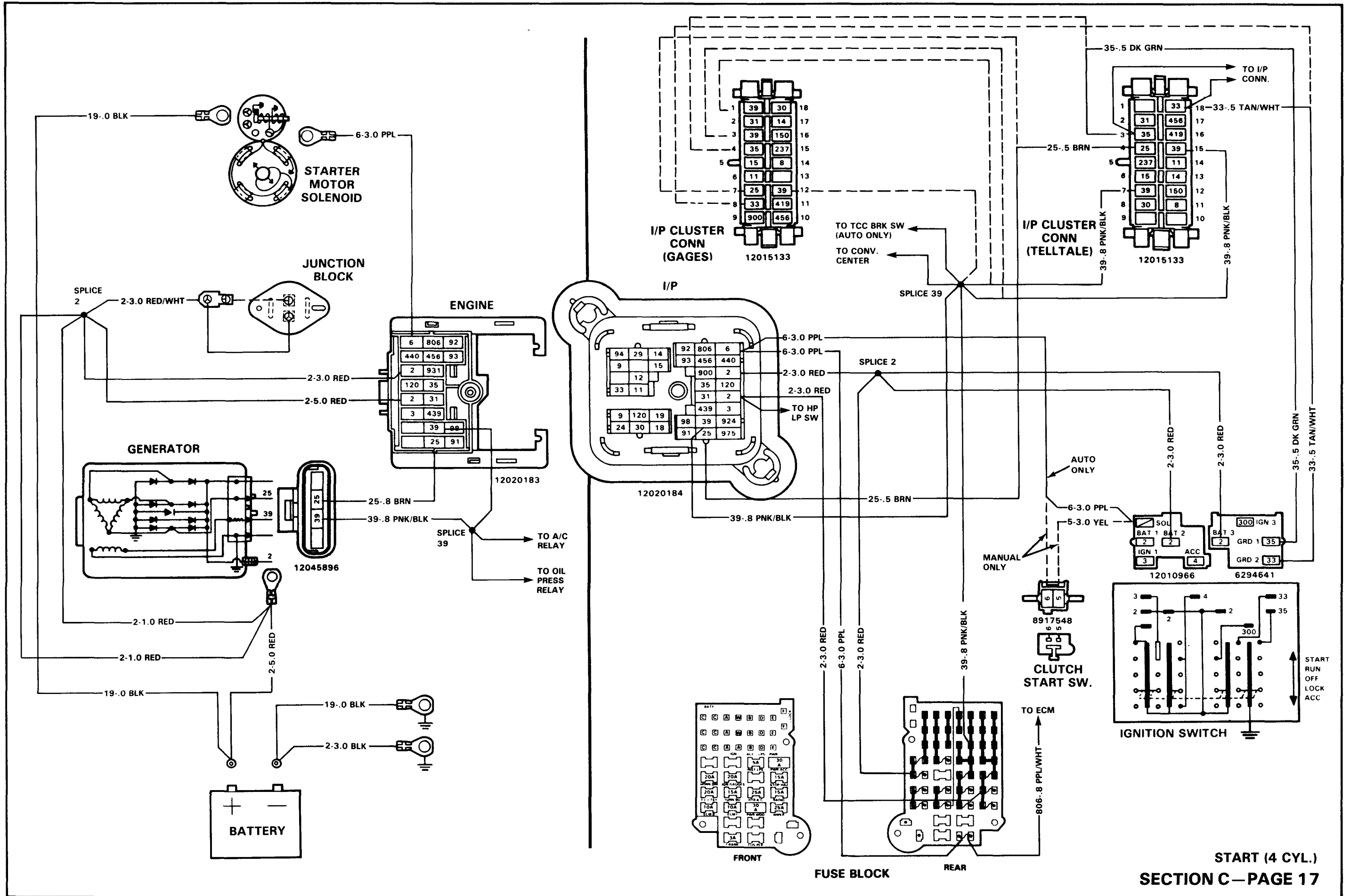

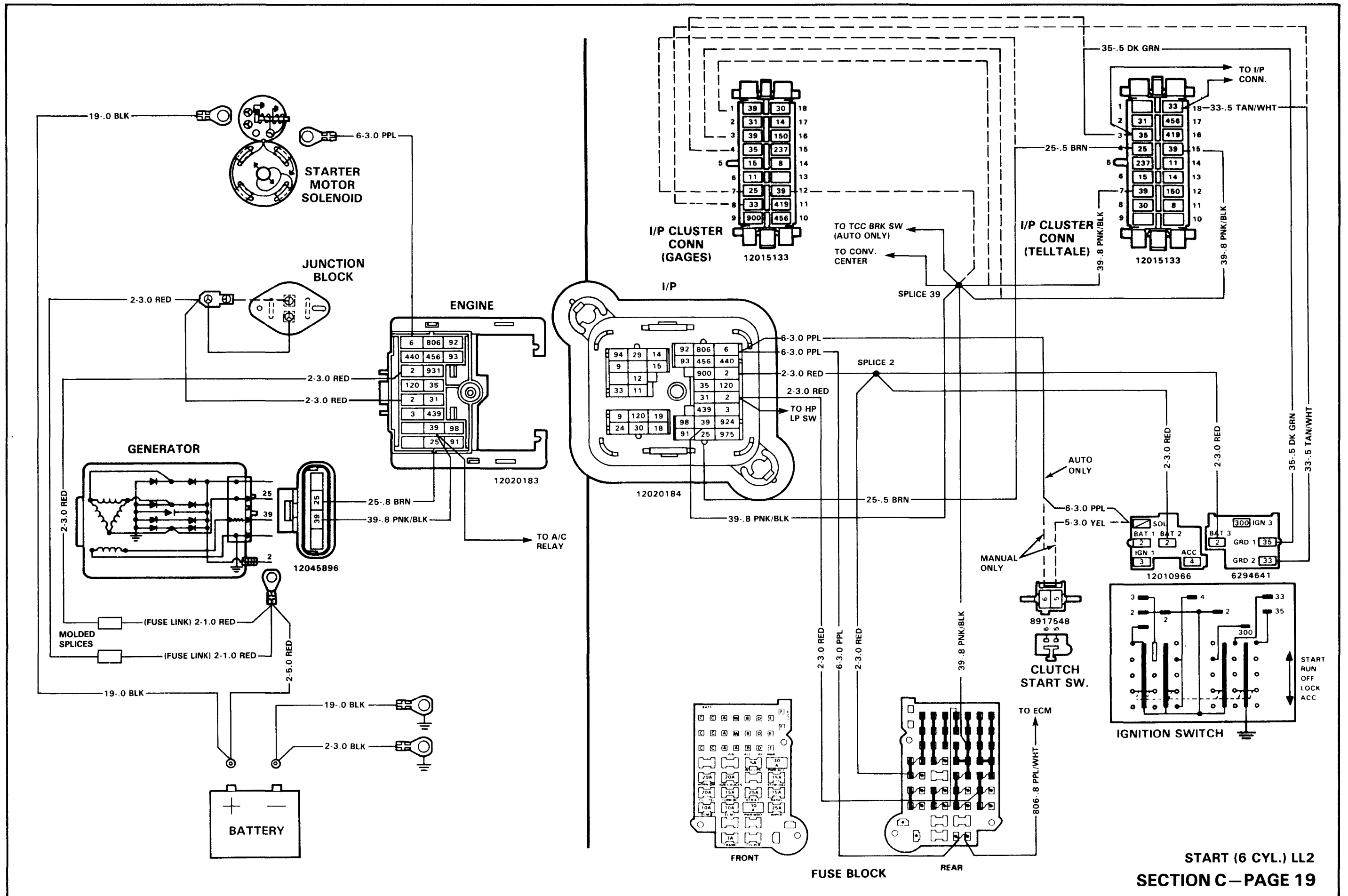

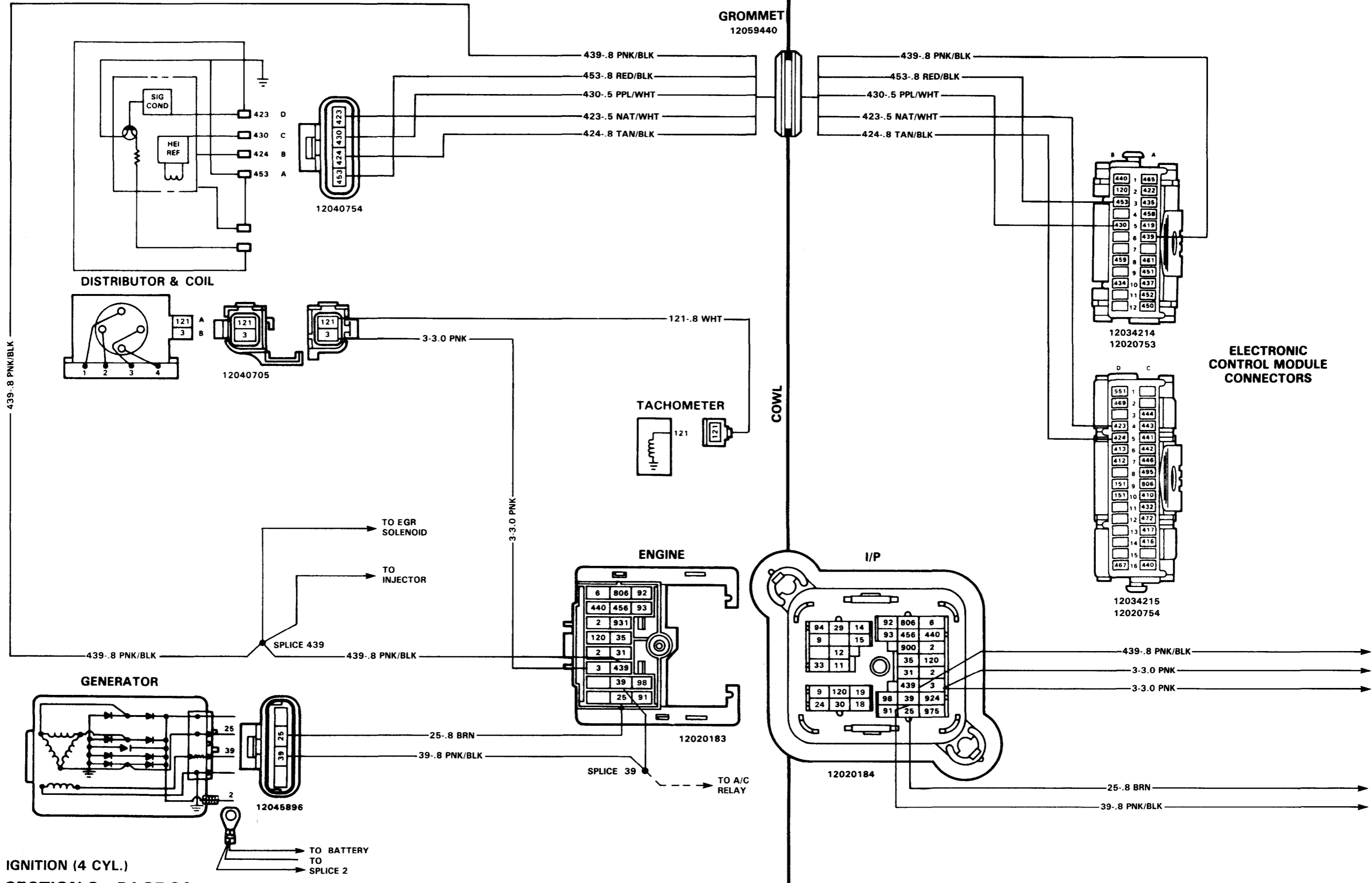

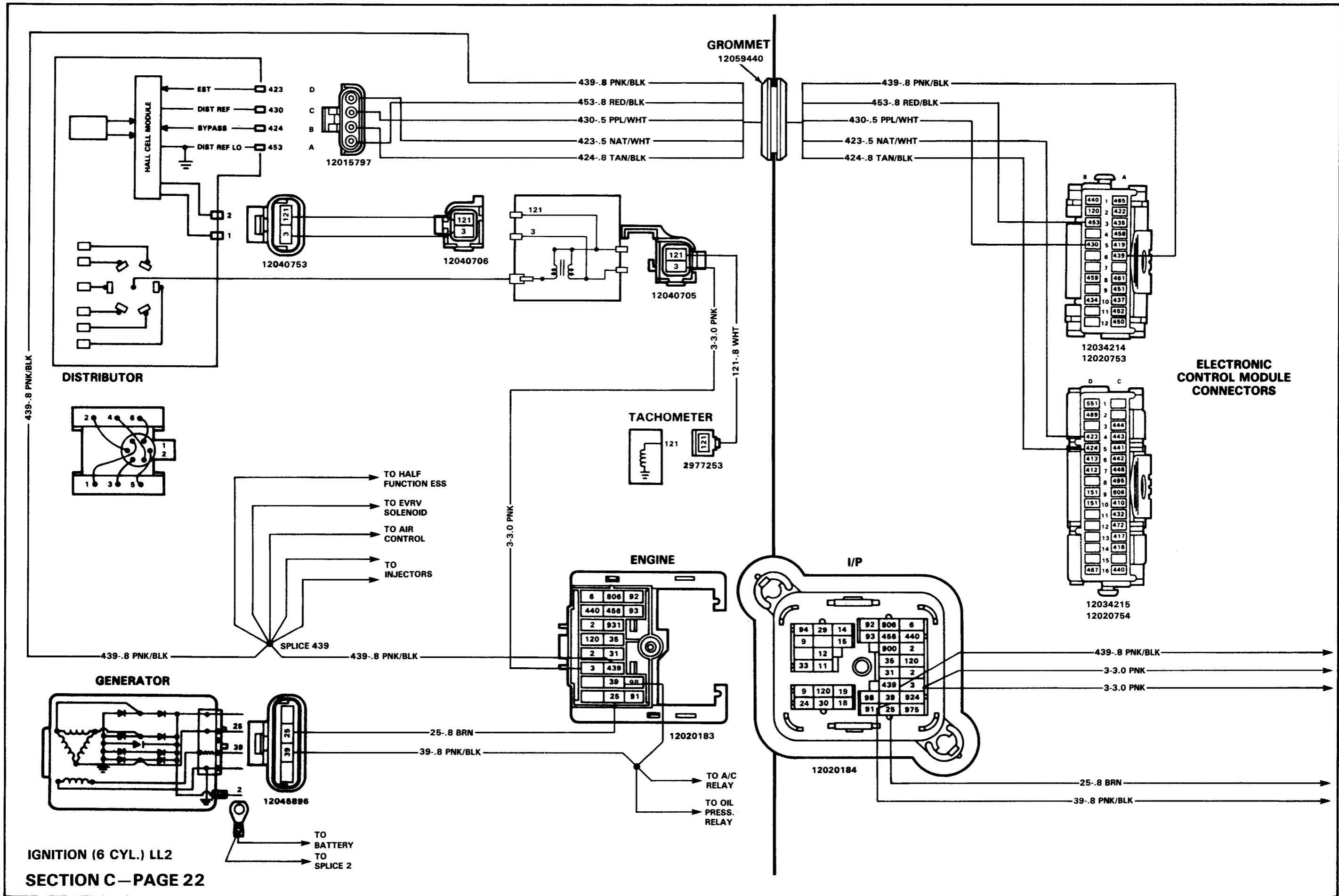

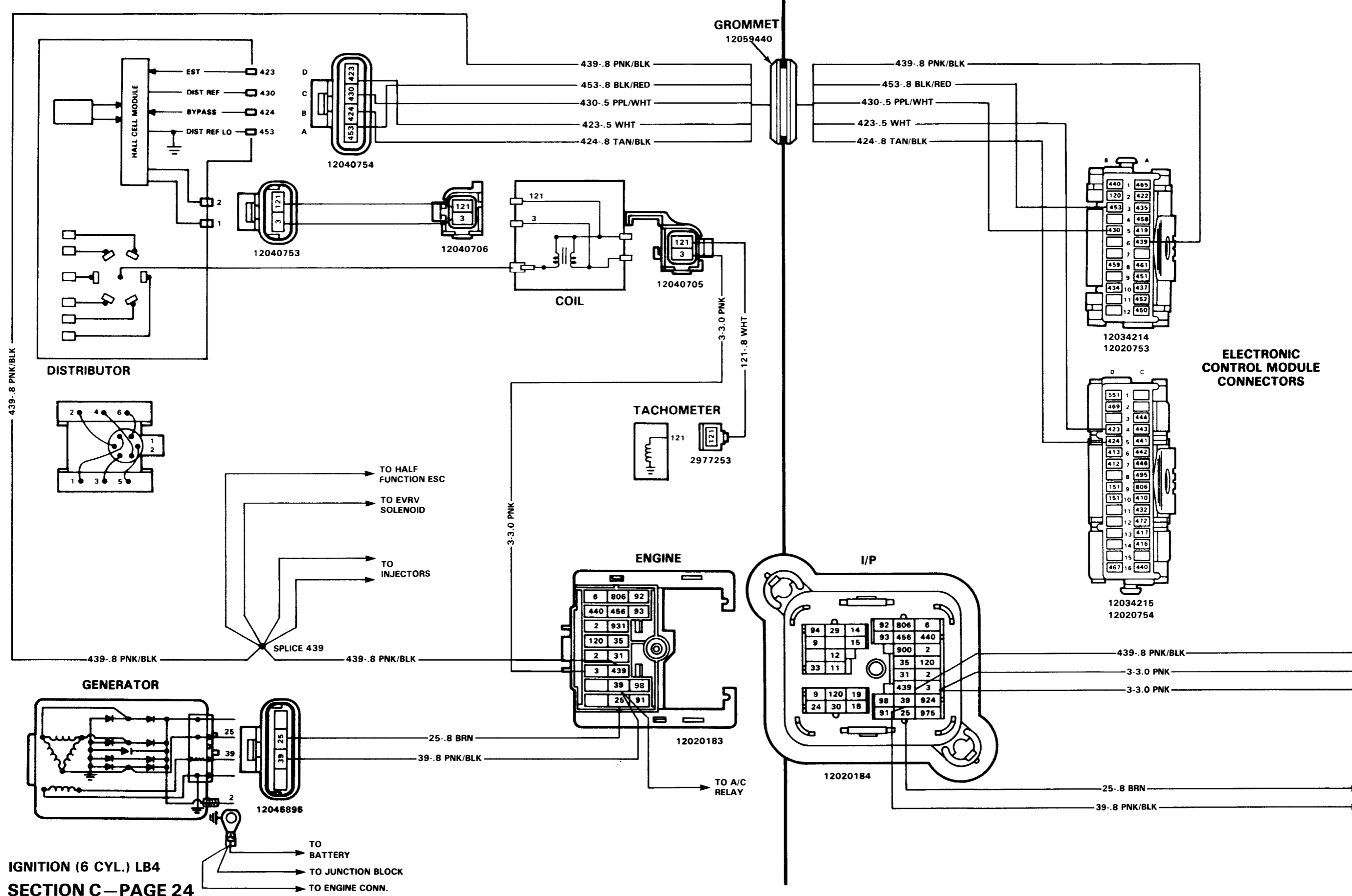

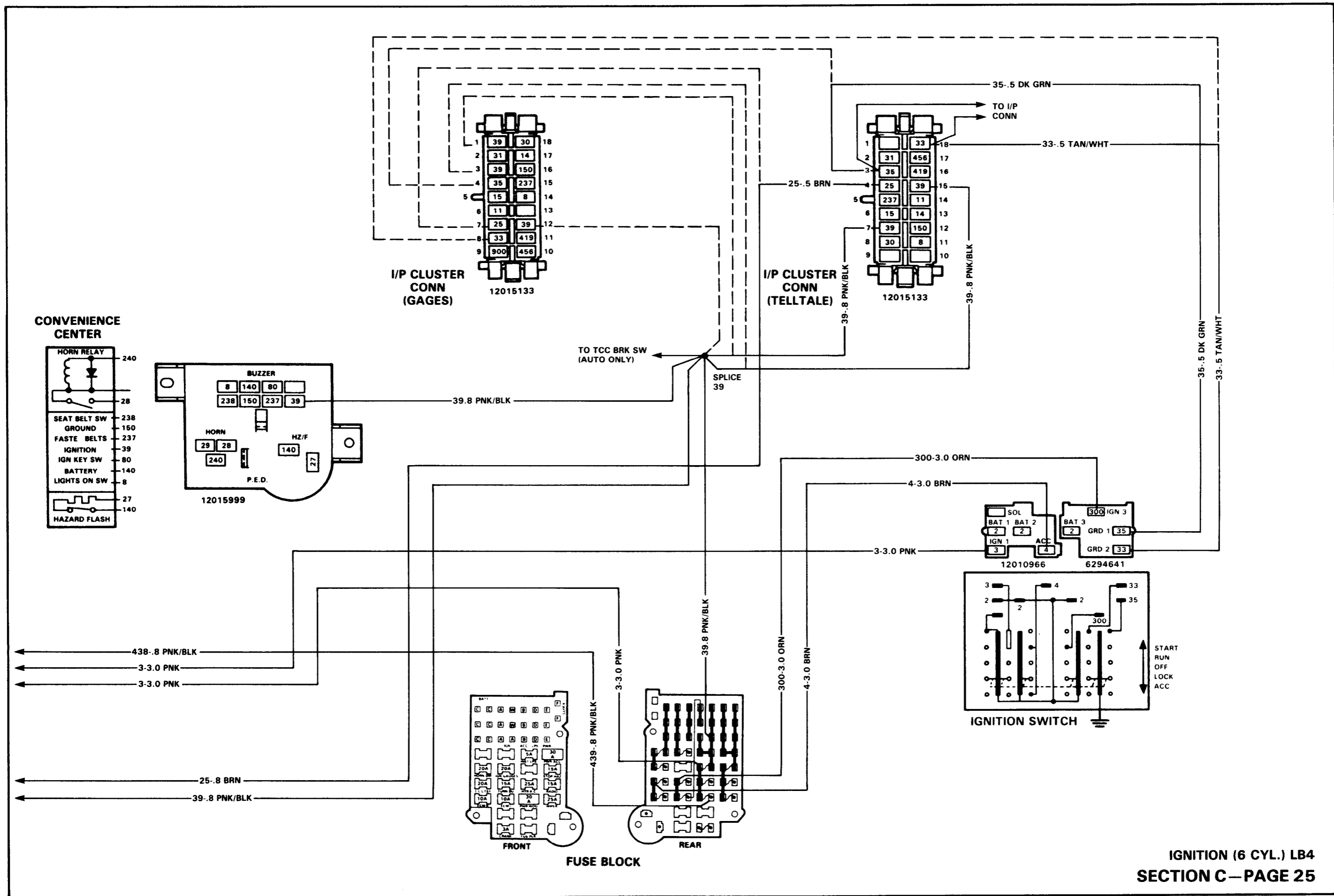

OXYGEN SENSOR

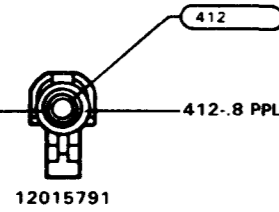
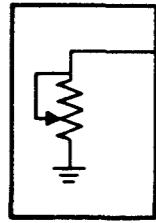

THROTTLE POSITION SENSOR

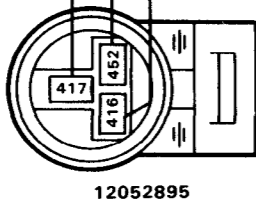
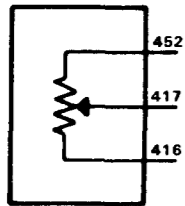

INJECTOR 1

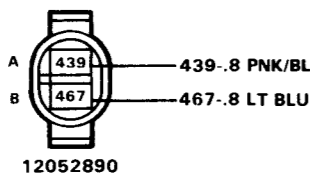
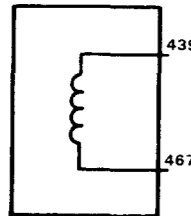

TO COOLANT TEMP. SENSOR

TO EGR SOLENOID

GROMMET 12059440

ENGINE

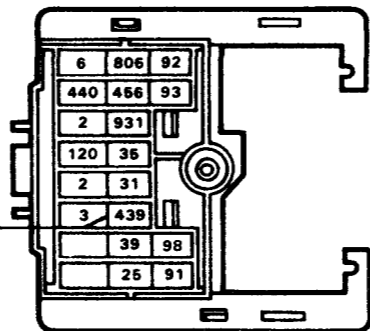

I/P

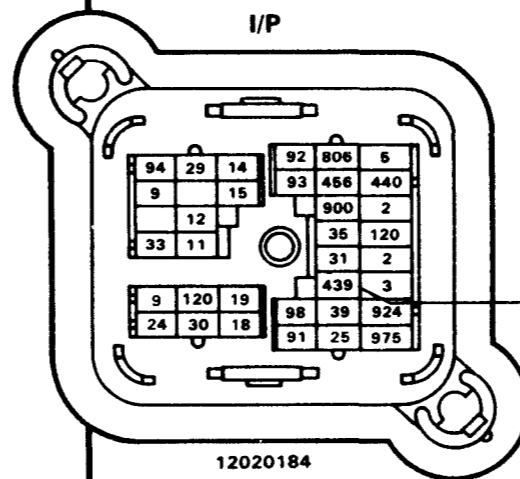

452-8 BLK

439-8 PNK/BLK

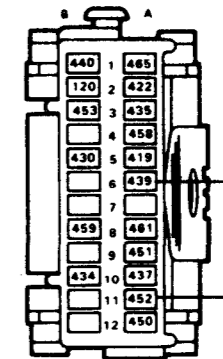

12020753

ELECTRONIC CONTROL MODULE CONNECTORS

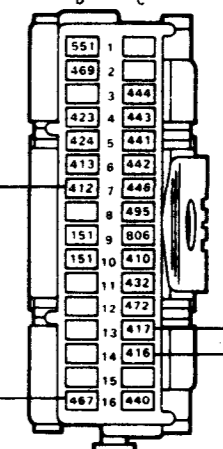

12020754

416-8 GRA

417-8 DK BLU

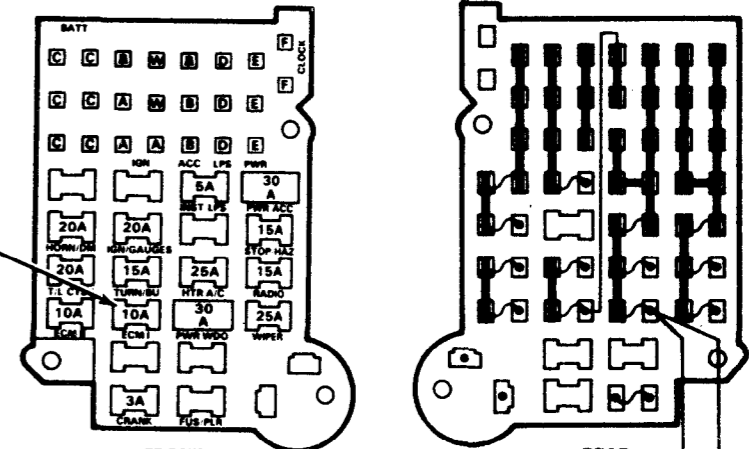

439-8 PNK/BLK

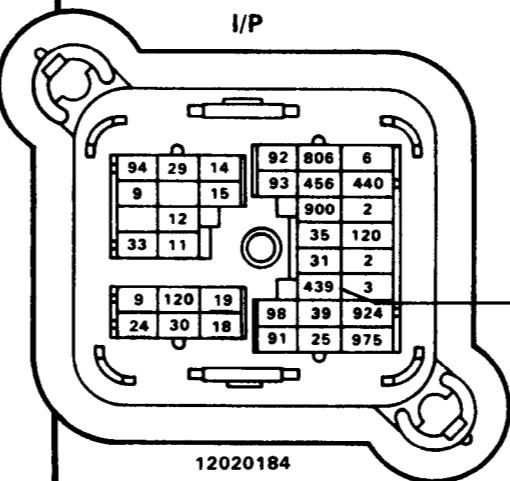
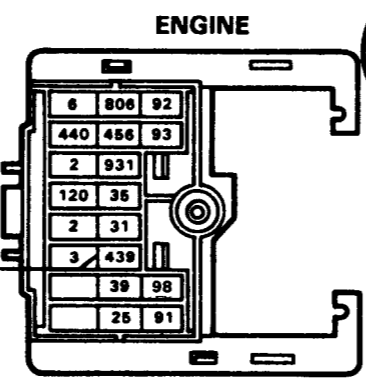
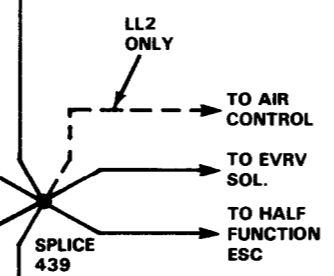
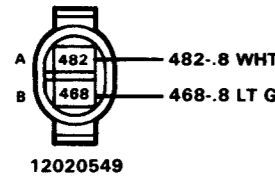
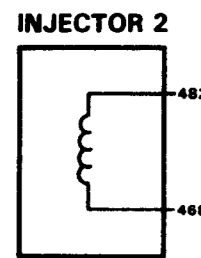
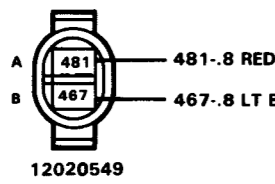
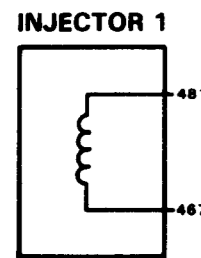
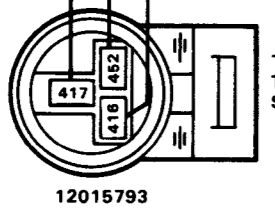
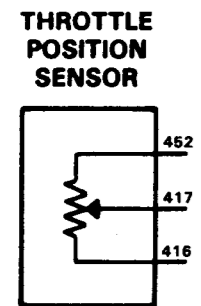
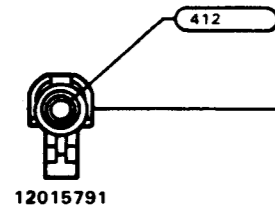
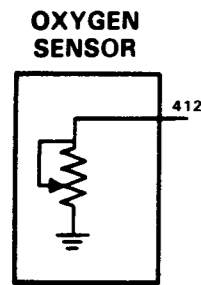

GROMMET
12059440

- 412-.5 PPL
- 417-.5 DK BLU
- 452-.5 BLK
- 416-.5 GRA
- 467-.8 LT BLU
- 467-.8 LT GRN
- 439-.8 PNK/BLK

- 412-.5 PPL
- 417-.5 DK BLU
- 452-.5 BLK
- 416-.5 GRA
- 467-.8 LT BLU
- 468-.8 LT GRN
- 439-.8 PNK/BLK

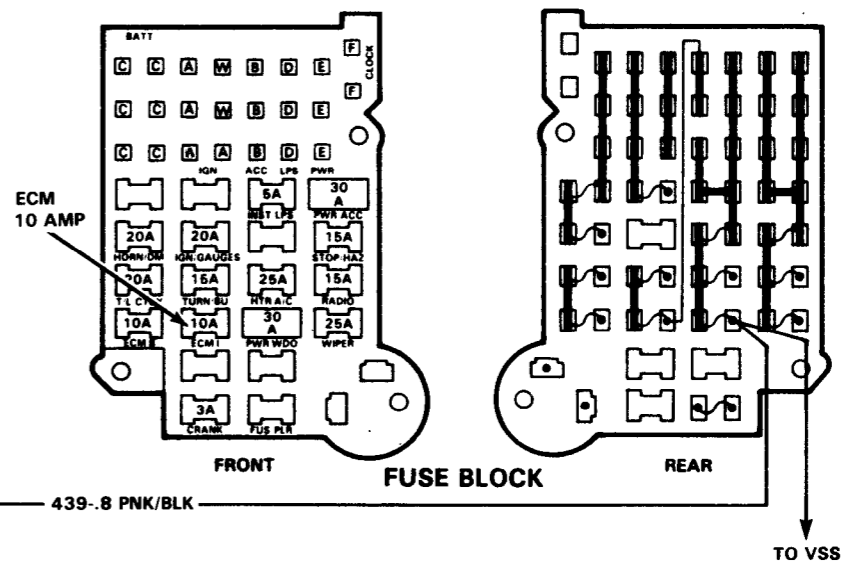
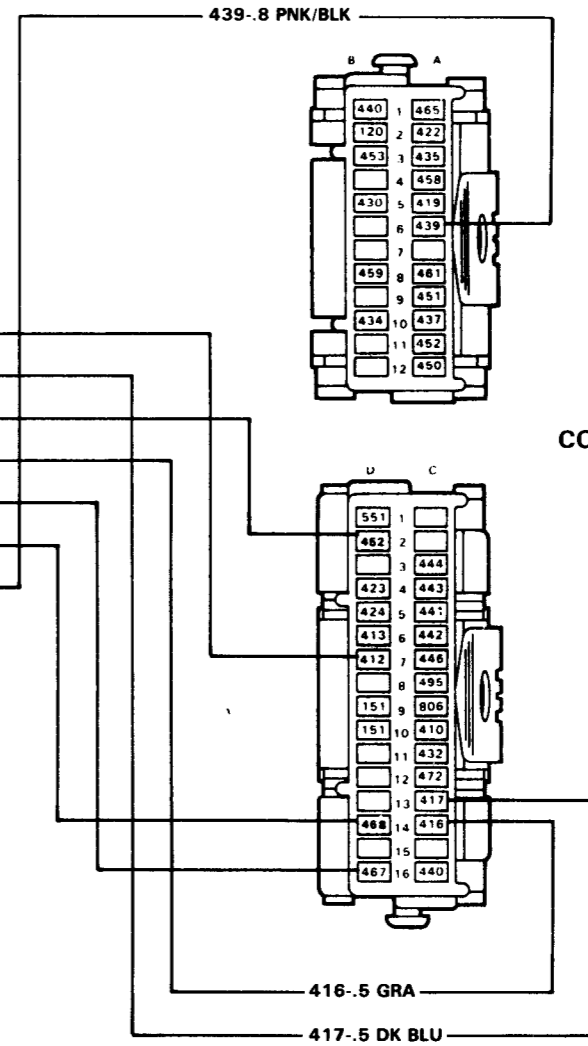

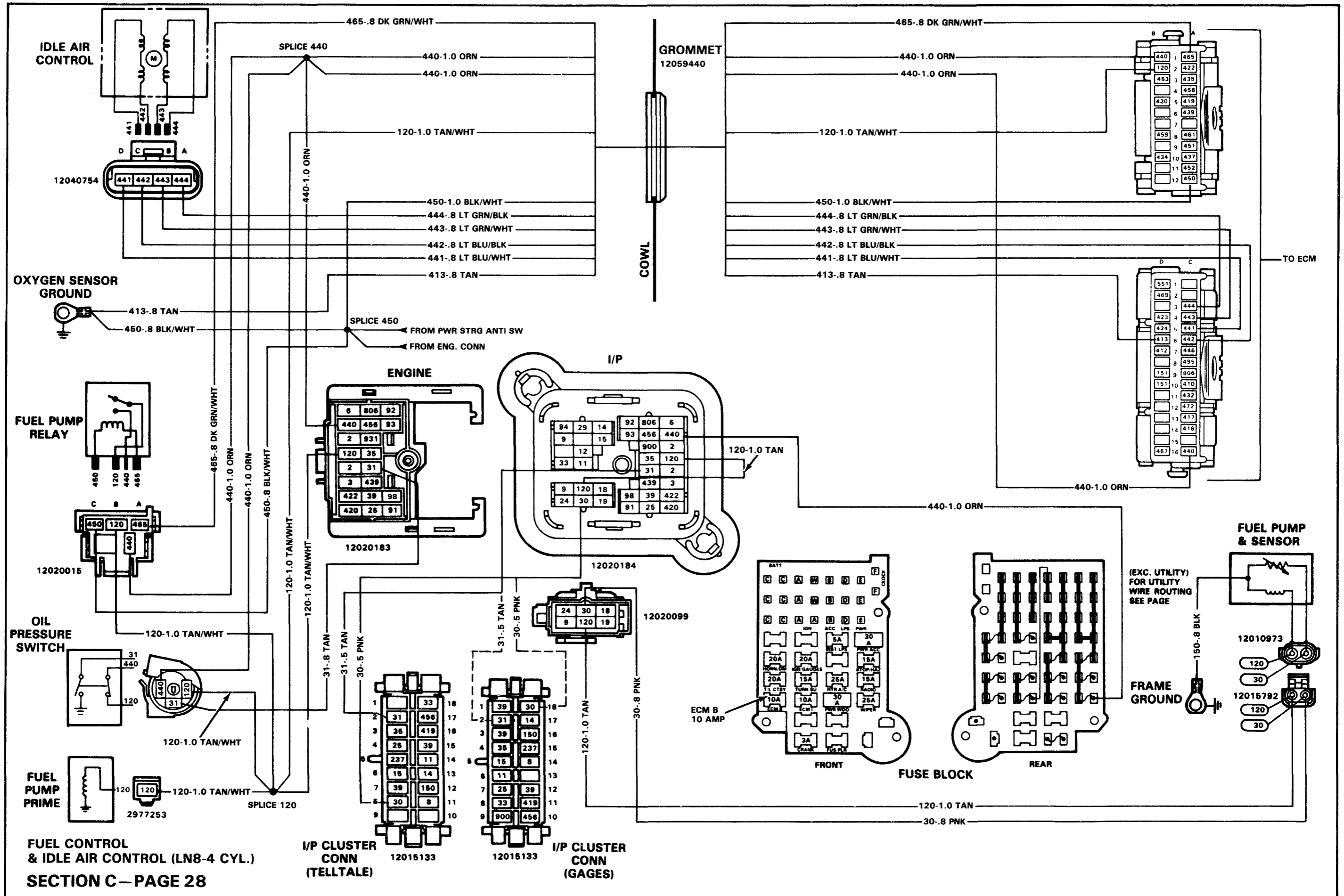

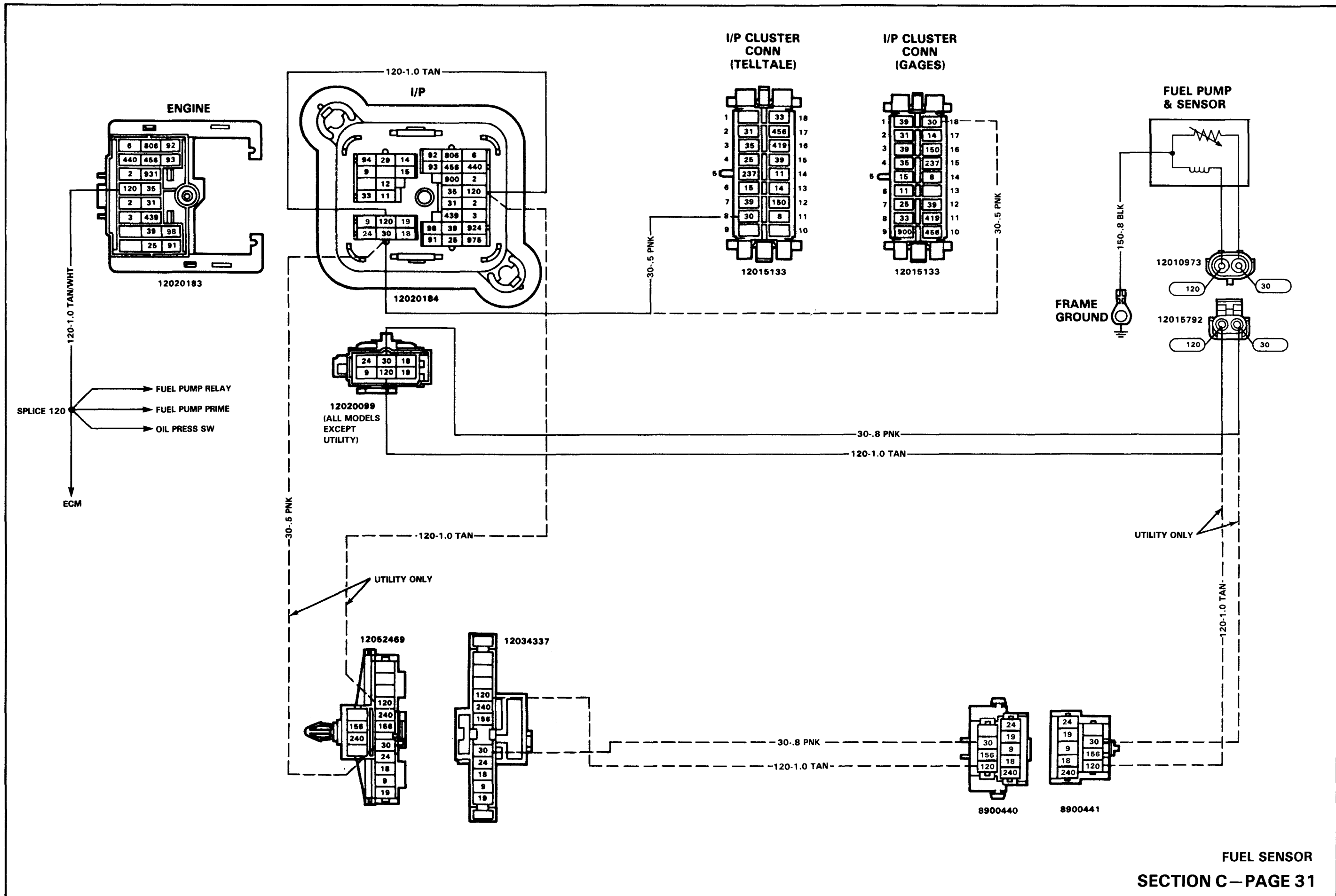

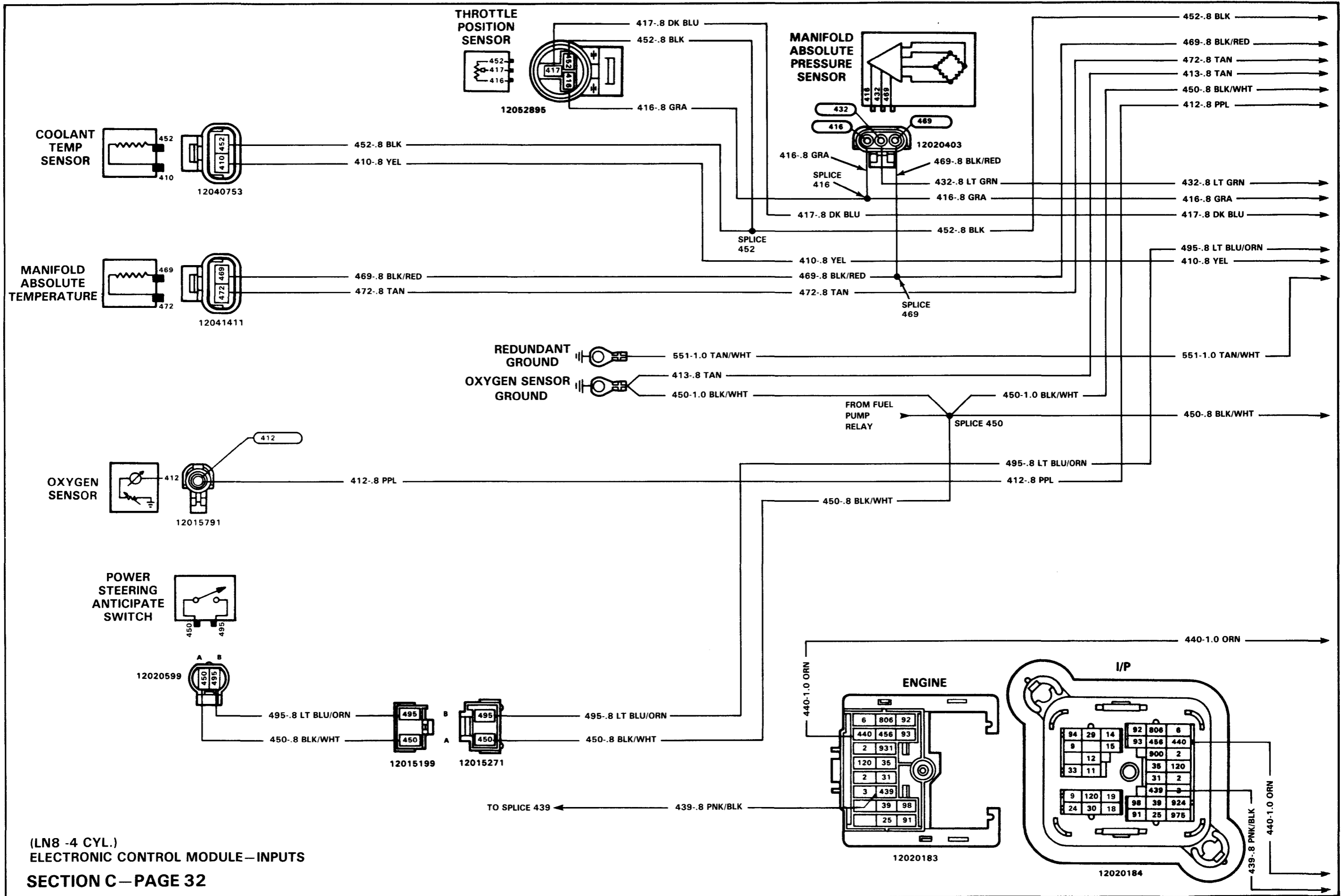

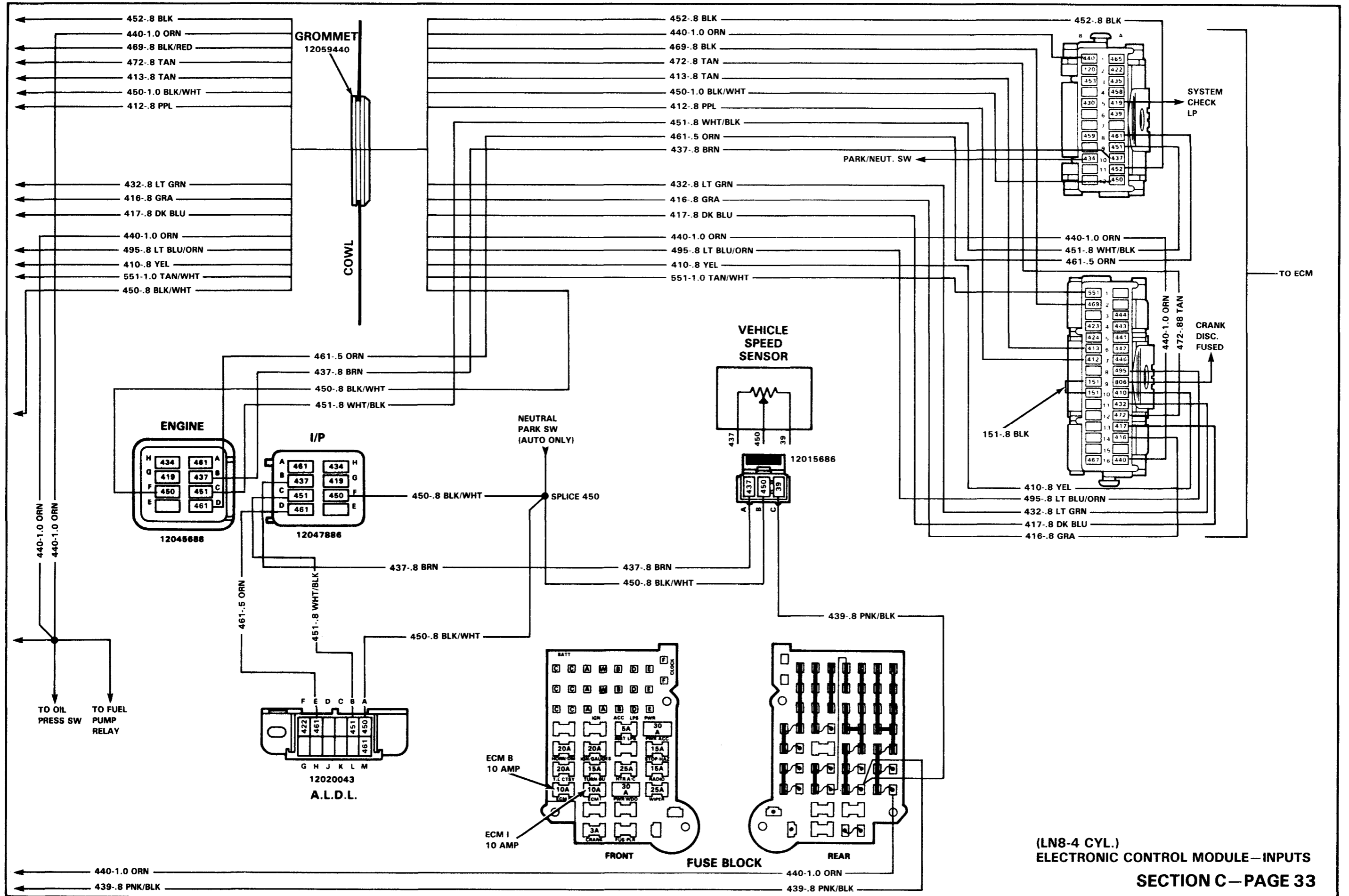

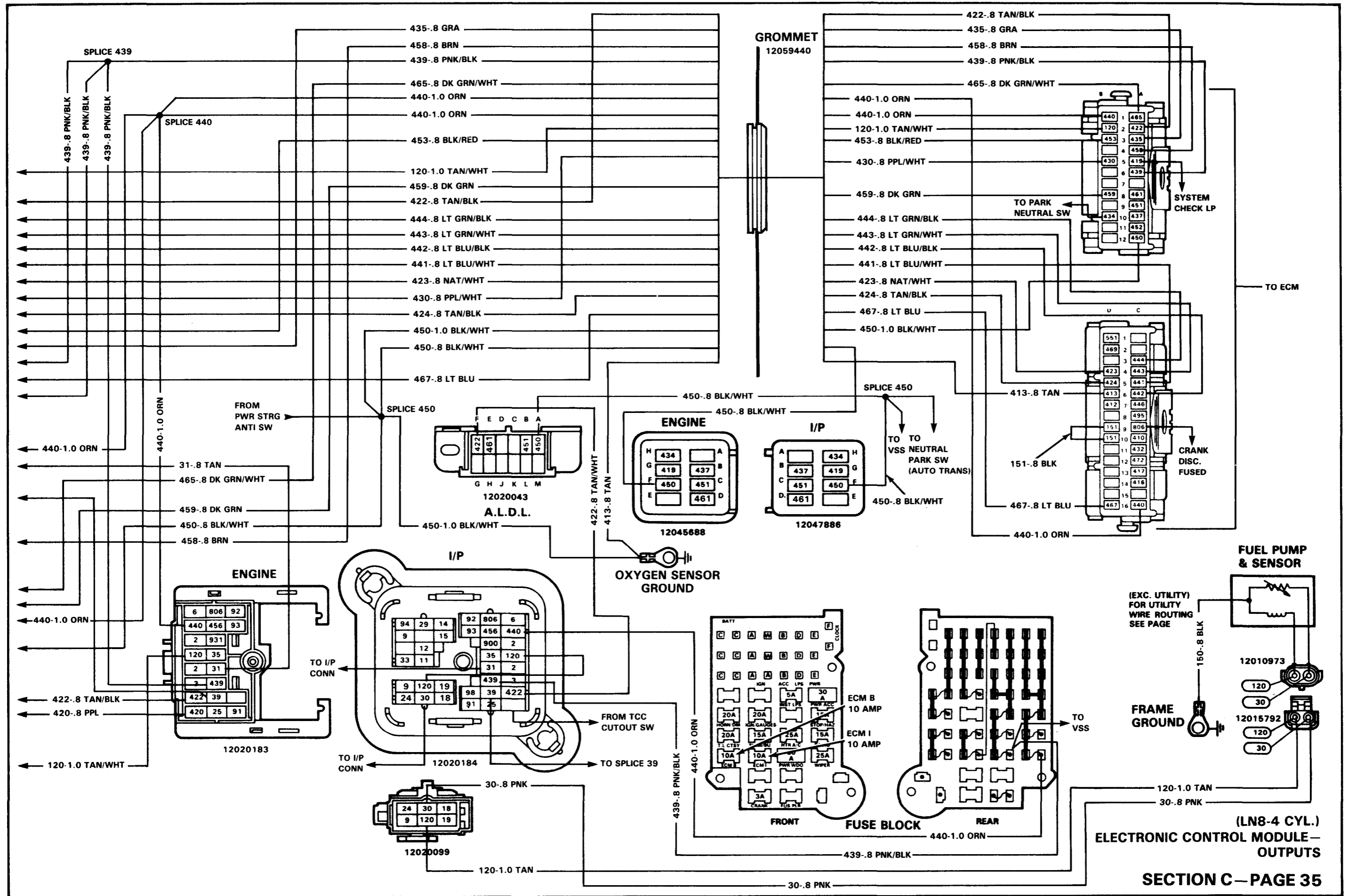

(LN8-4 CYL.)
ELECTRONIC CONTROL MODULE—
OUTPUTS

CIRCUIT NO.	WIRE SIZE	COLOR	CAVITY	DESCRIPTION
465	.8	DK GRN/WHT	A1	FUEL PUMP RELAY DRIVE
* 422	.8	TAN/BLK	A2	TORQUE CONVERTER CLUTCH
* 456	.8	TAN/BLK	A2	UPSHIFT MAN—ONLY
435	.8	GRA	A3	EGR SOLENOID
458	.8	BRN	A4	A/C RELAY
419	.8	BRN/WHT	A5	SYSTEM CHECK LAMP
439	1.0	PNK/BLK	A6	12V IGNITION FUSED
			A7	NOT USED
461	.8	ORN	A8	SERIAL DATA
451	.8	NAT/WHT	A9	ASSY LINE LINK/DIAG.
437	.8	BRN	A10	SPEED SENSOR
452	.8	BLK	A11	5V RETURN B
450	1.0	BLK/WHT	A12	SYSTEM RETURN
440	1.0	ORN	B1	12V BATTERY FUSED
120	1.0	TAN/WHT	B2	ELEC FUEL PUMP FUSED FEED
453	.8	BLK/RED	B3	DISTRIBUTOR REF LOW
			B4	NOT USED
430	.8	PPL/WHT	B5	DISTRIBUTOR REF HIGH
			B6	NOT USED
			B7	NOT USED
459	.8	DK GRN	B8	AIR CONDITION
			B9	NOT USED
△ 434	.8	ORN/BLK	B10	PARK/NEUTRAL SWITCH
			B11	NOT USED
			B12	NOT USED

* 422—AUTO TRANS ONLY

* 456—MAN TRANS ONLY

△ AUTO TRANS ONLY

CIRCUIT NO.	WIRE SIZE	COLOR	CAVITY	DESCRIPTION
			C1	NOT USED
			C2	NOT USED
444	.8	LT GRN/BLK	C3	STEPPER COIL B LOW
443	.8	LT GRN/WHT	C4	STEPPER COIL B HIGH
441	.8	LT BLU/WHT	C5	STEPPER COIL A HIGH
442	.8	LT BLU/BLK	C6	STEPPER COIL A LOW
			C7	NOT USED
495	.8	LT BLU/ORN	C8	PWR STRG CUTOUT SW
806	.8	PPL	C9	CRANK DISCRETE FUSED
410	.8	YEL	C10	COOLANT TEMPERATURE
432	.8	LT GRN	C11	MANIFOLD ABSOLUTE PRESS
472	.8	TAN	C12	MANIFOLD AIR TEMP SIGNAL
417	.8	DK BLU	C13	THROTTLE POSITION SENSOR
416	.8	GRA	C14	5V SENSOR REFERENCE
			C15	NOT USED
440	1.0	ORN	C16	12V BATTERY FUSED
551	1.0	TAN/WHT	D1	SYSTEM GROUND
469	.8	BLK/RED	D2	5V SYSTEM RETURN A
			D3	NOT USED
423	.8	NAT/WHT	D4	HEI SPARK TIMING
424	.8	TAN/BLK	D5	HEI BYPASS
413	.8	TAN	D6	OXYGEN SENSOR LOW
412	.8	PPL	D7	OXYGEN SENSOR HIGH
			D8	NOT USED
151	.8	BLK	D9	GROUND
151	.8	BLK	D10	GROUND
			D11	NOT USED
			D12	NOT USED
			D13	NOT USED
			D14	NOT USED
			D15	NOT USED
467	.8	LT BLU	D16	INJECTOR A DRIVE

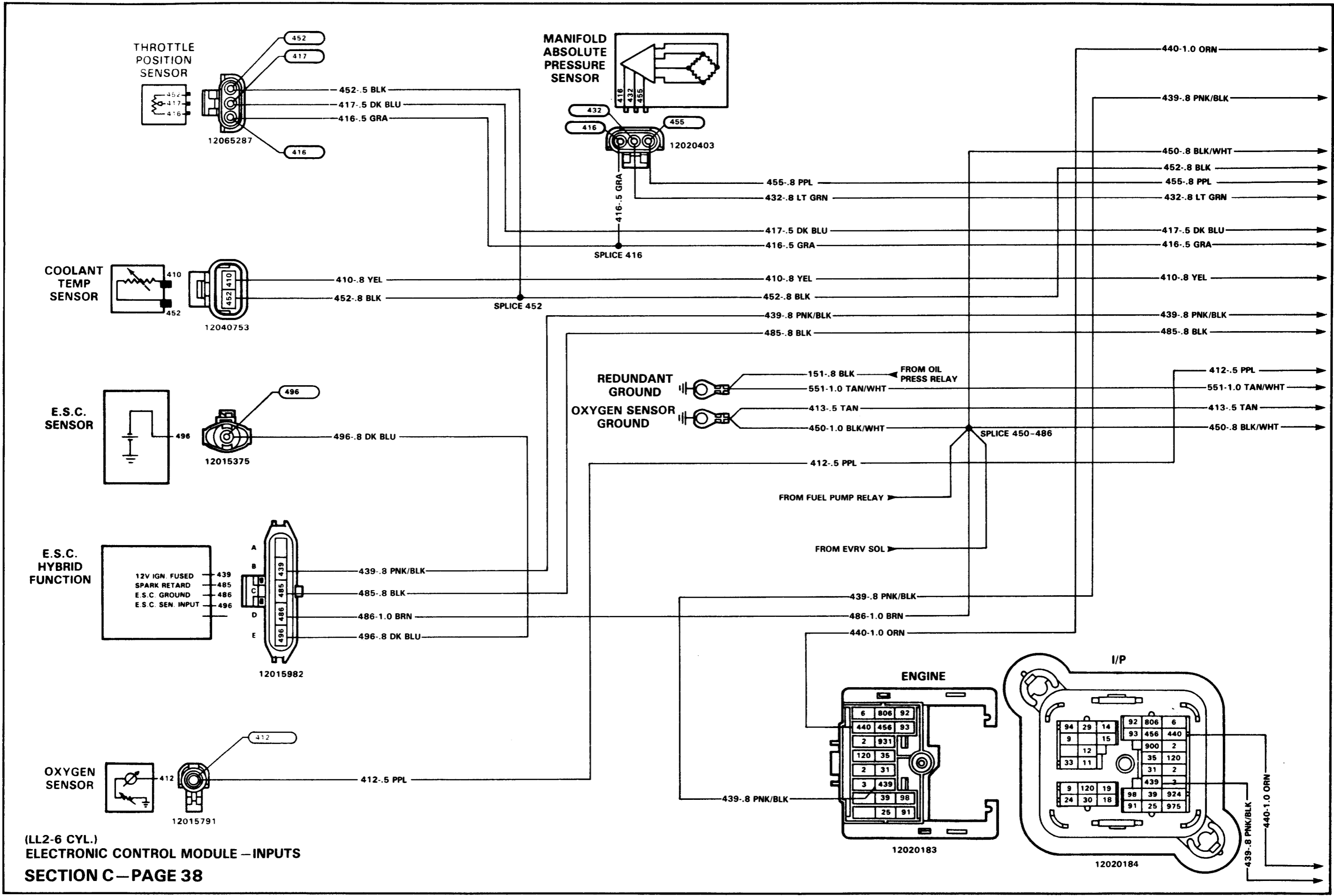

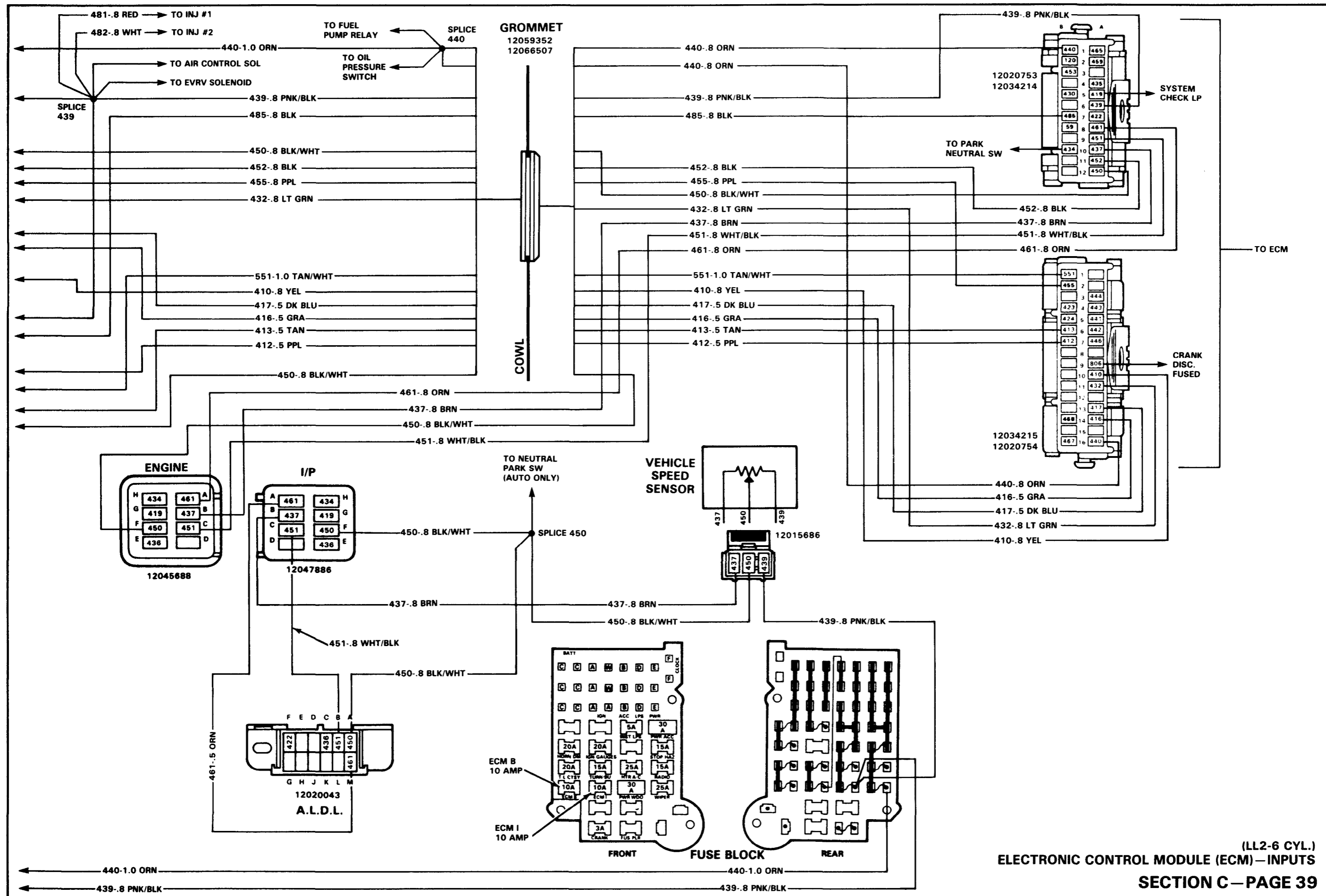

(LL2-6 CYL.)
ELECTRONIC CONTROL MODULE (ECM) - INPUTS
SECTION C - PAGE 39

CIRCUIT NO.	WIRE SIZE	COLOR	CAVITY	DESCRIPTION
465	.8	DK GRN/WHT	A1	FUEL PUMP RELAY DRIVE
459	.8	DK GRN/WHT	A2	A/C RELAY
			A3	NOT USED
435	.5	GRA	A4	EVRV SOLENOID
419	.8	BRN/WHT	A5	SYSTEM CHECK LAMP
439	.8	PNK/BLK	A6	12V IGNITION FUSED
* 422	.8	TAN/BLK	A7	TORQUE CONVERTER CLUTCH
* 456	.8	TAN/BLK	A7	UPSHIFT MAN— ONLY
461	.8	ORN	A8	SERIAL DATA
451	.8	NAT/WHT	A9	ASS'Y LINE LINK/DIAG
437	.8	BRN	A10	SPEED SENSOR
455	.8	PPL	A11	5V SYSTEM RETURN A
450	1.0	BLK/WHT	A12	SYSTEM RETURN
440	.8	ORN	B1	12V BATTERY FUSED
120	1.0	TAN/WHT	B2	ELEC FUEL PUMP FUSED FEED
453	.8	RED/BLK	B3	DISTRIBUTOR REF LOW
			B4	NOT USED
430	.5	PPL/WHT	B5	DISTRIBUTOR REF HIGH
			B6	NOT USED
485	.8	BLK	B7	SPARK RETARD CONTROL
59	1.0	DK BRN	B8	AIR CONDITION
			B9	NOT USED
△ 434	.5	ORN/BLK	B10	PARK/NEUTRAL SWITCH
			B11	NOT USED
			B12	NOT USED

- * 422—AUTO TRANS ONLY
- * 456—MAN TRANS ONLY
- △ AUTO TRANS ONLY

CIRCUIT NO.	WIRE SIZE	COLOR	CAVITY	DESCRIPTION
			C1	NOT USED
436	.8	PNK/BLK	C2	AIR SW SOLENOID
444	.8	LT GRN/BLK	C3	STEPPER COIL B LOW
443	.8	LT GRN/WHT	C4	STEPPER COIL B HIGH
441	.8	LT BLU/WHT	C5	STEPPER COIL A HIGH
442	.8	LT BLU/BLK	C6	STEPPER COIL A LOW
			C7	NOT USED
			C8	NOT USED
806	.8	PPL/WHT	C9	CRANK DISCRETE FUSED
410	.8	YEL	C10	COOLANT TEMPERATURE
432	.8	LT GRN	C11	MANIFOLD ABSOLUTE PRESS
			C12	NOT USED
417	.5	DK BLU	C13	THROTTLE POSITION SENSOR
416	.5	GRA	C14	5V SENSOR REFERENCE
			C15	NOT USED
440	.8	ORN	C16	12V BATTERY FUSED
551	1.0	TAN/WHT	D1	SYSTEM RETURN
452	.5	BLK	D2	5V SYSTEM RETURN B
			D3	NOT USED
423	.5	NAT/WHT	D4	HEI SPARK TIMING
424	.8	TAN/BLK	D5	HEI BYPASS
413	.5	TAN	D6	OXYGEN SENSOR LOW
412	.5	PPL	D7	OXYGEN SENSOR HIGH
			D8	NOT USED
			D9	NOT USED
			D10	NOT USED
			D11	NOT USED
			D12	NOT USED
			D13	NOT USED
468	.8	LT GRN	D14	INJECTOR B DRIVE
			D15	NOT USED
467	.8	LT BLU	D16	INJECTOR A DRIVE

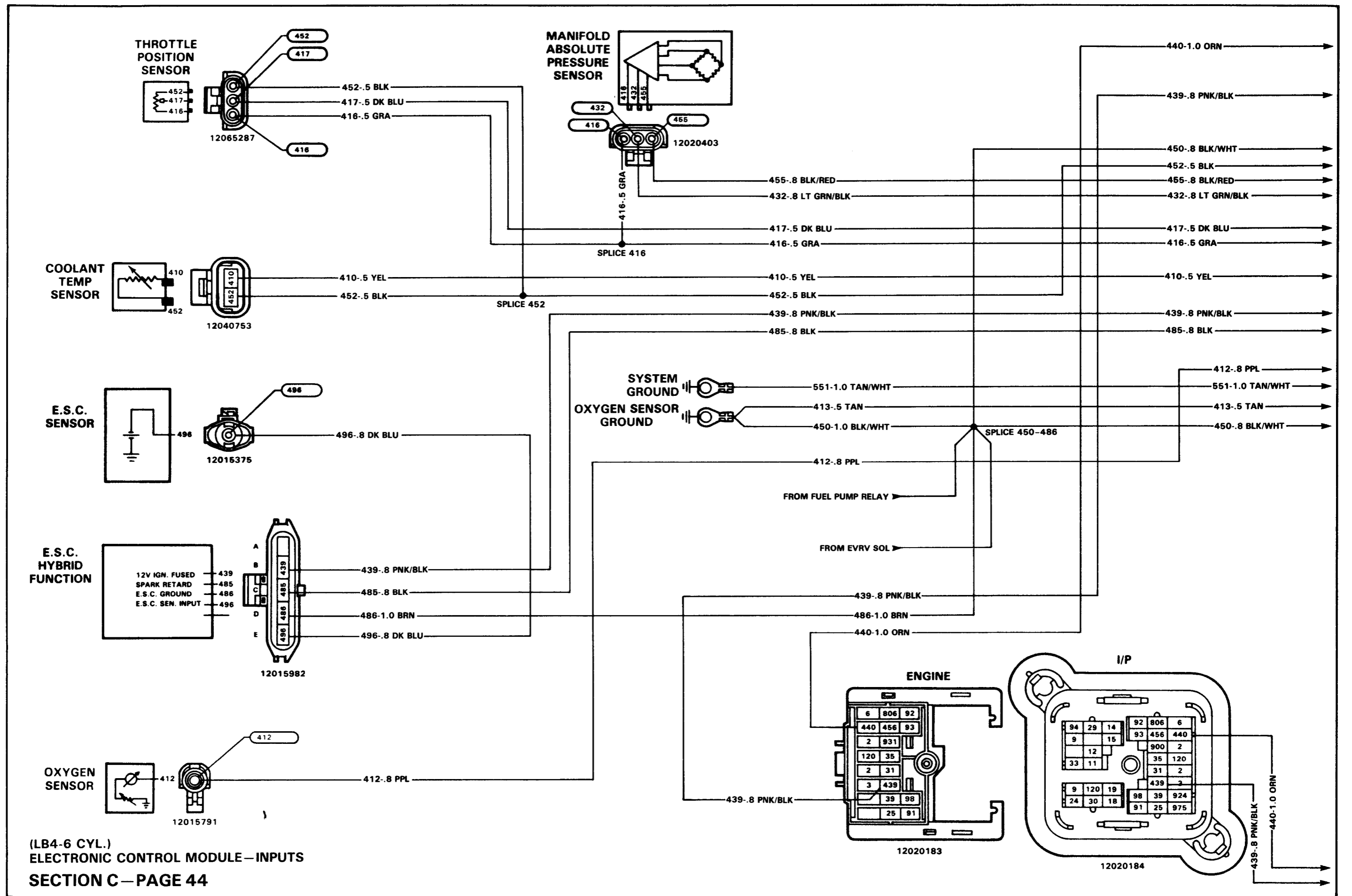

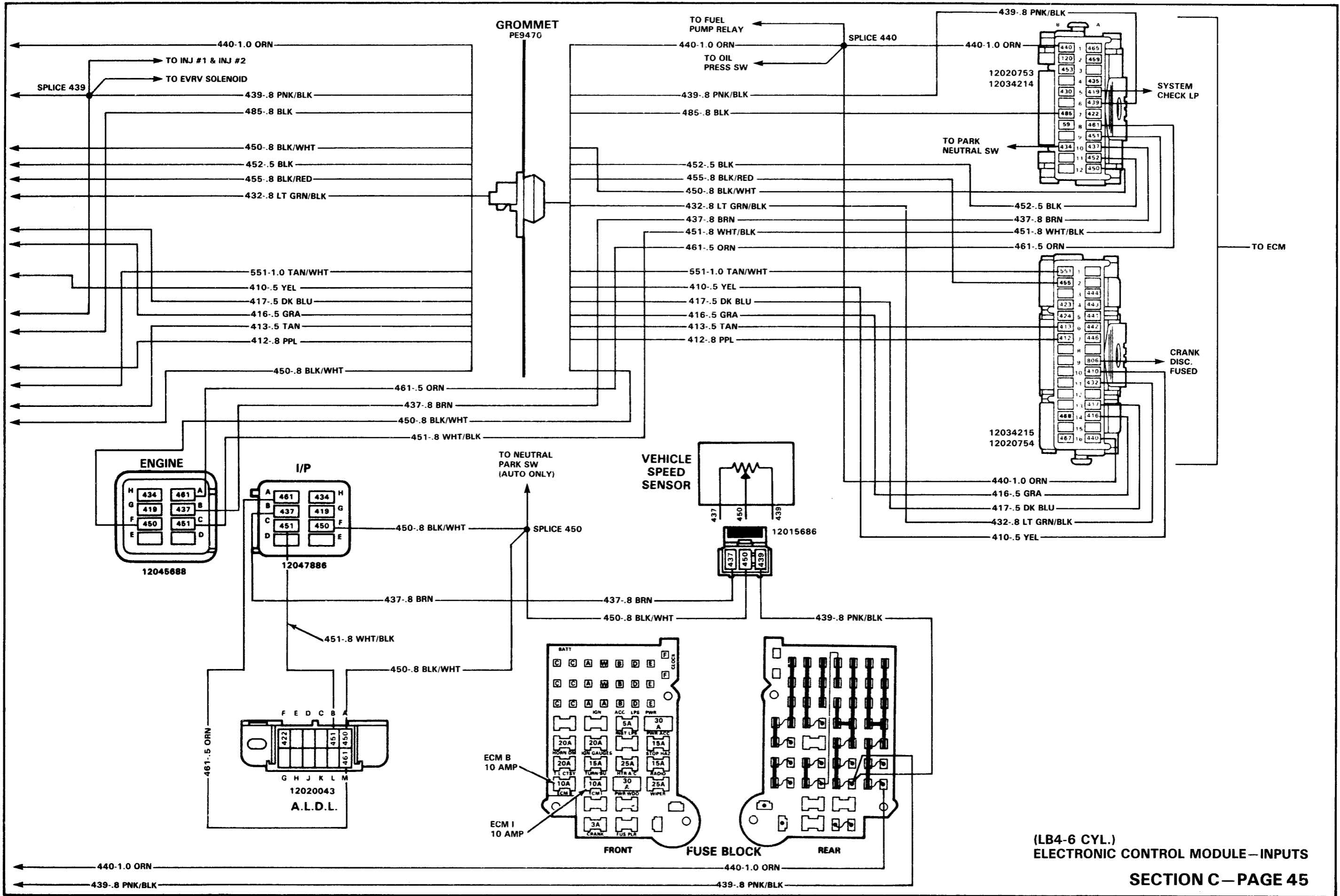

(LB4-6 CYL.)
ELECTRONIC CONTROL MODULE—INPUTS

CIRCUIT NO.	WIRE SIZE	COLOR	CAVITY	DESCRIPTION
465	.8	DK GRN/WHT	A1	FUEL PUMP RELAY DRIVE
459	.8	DK GRN/WHT	A2	A/C RELAY
			A3	NOT USED
435	.5	GRA	A4	EVRV SOLENOID
419	.8	BRN/WHT	A5	SYSTEM CHECK LAMP
439	.8	PNK/BLK	A6	12V IGNITION FUSED
422	.8	TAN/BLK	A7	TORQUE CONVERTER CLUTCH
456	.8	TAN/BLK	A7	UPSHIFT MAN— ONLY
461	.8	ORN	A8	SERIAL DATA
451	.8	NAT/WHT	A9	ASS'Y LINE LINK/DIAG
437	.8	BRN	A10	SPEED SENSOR
455	.8	PPL	A11	5V SYSTEM RETURN A
450	.8	BLK/WHT	A12	SYSTEM RETURN
440	.8	ORN	B1	12V BATTERY FUSED
120	.8	TAN/WHT	B2	ELEC.FUEL PUMP FUSED FEED
453	.8	RED/BLK	B3	DISTRIBUTOR REF LOW
			B4	NOT USED
430	.5	PPL/WHT	B5	DISTRIBUTOR REF HIGH
			B6	NOT USED
485	.8	BLK	B7	SPARK RETARD CONTROL
59	.5	DK BRN	B8	AIR CONDITION
			B9	NOT USED
434	.5	ORN/BLK	B10	PARK/NEUTRAL SWITCH
			B11	NOT USED
			B12	NOT USED

CIRCUIT NO.	WIRE SIZE	COLOR	CAVITY	DESCRIPTION
			C1	NOT USED
			C2	NOT USED
444	.8	LT GRN/BLK	C3	STEPPER COIL B LOW
443	.8	LT GRN/WHT	C4	STEPPER COIL B HIGH
441	.8	LT BLU/WHT	C5	STEPPER COIL A HIGH
442	.8	LT BLU/BLK	C6	STEPPER COIL A LOW
446	.8	LT BLU	C7	TCC SOLENOID
			C8	NOT USED
806	.8	PPL/WHT	C9	CRANK DISCRETE FUSED
410	.8	YEL	C10	COOLANT TEMPERATURE
432	.8	LT GRN	C11	MANIFOLD ABSOLUTE PRESS.
			C12	NOT USED
417	.5	DK BLU	C13	THROTTLE POSITION SENSOR
416	.5	GRA	C14	5V SENSOR REFERENCE
			C15	NOT USED
440	.8	ORN	C16	12V BATTERY FUSED
551	1.0	TAN/WHT	D1	SYSTEM RETURN
455	.5	PPL	D2	5V SYSTEM RETURN B
			D3	NOT USED
423	.5	NAT/WHT	D4	HEI SPARK TIMING
424	.8	TAN/BLK	D5	HEI BYPASS
413	.5	TAN	D6	OXYGEN SENSOR LOW
412	.5	PPL	D7	OXYGEN SENSOR HIGH
			D8	NOT USED
			D9	NOT USED
			D10	NOT USED
			D11	NOT USED
			D12	NOT USED
			D13	NOT USED
468	.8	LT GRN	D14	INJECTOR B DRIVE
			D15	NOT USED
467	.8	LT BLU	D16	INJECTOR A DRIVE

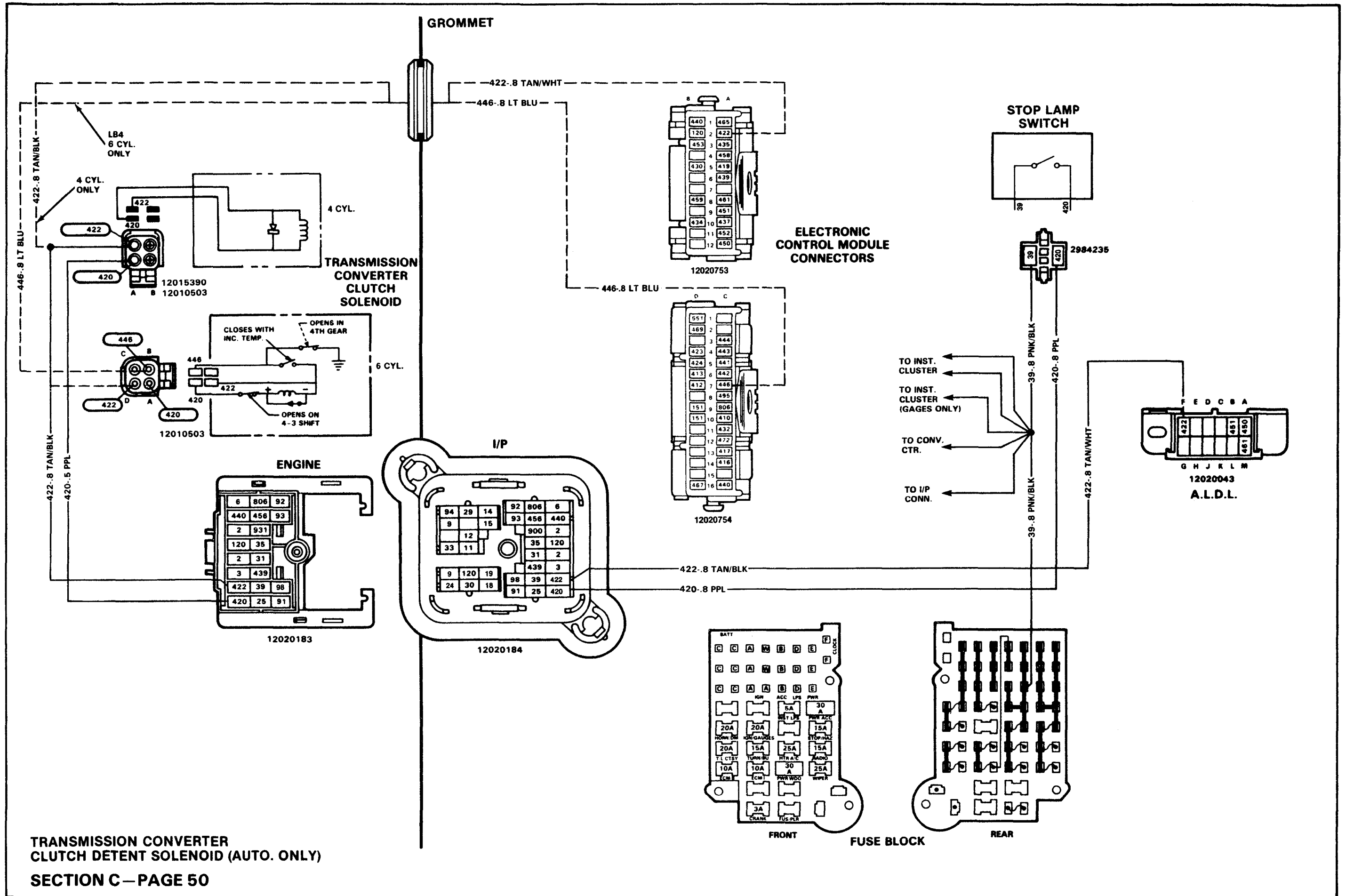

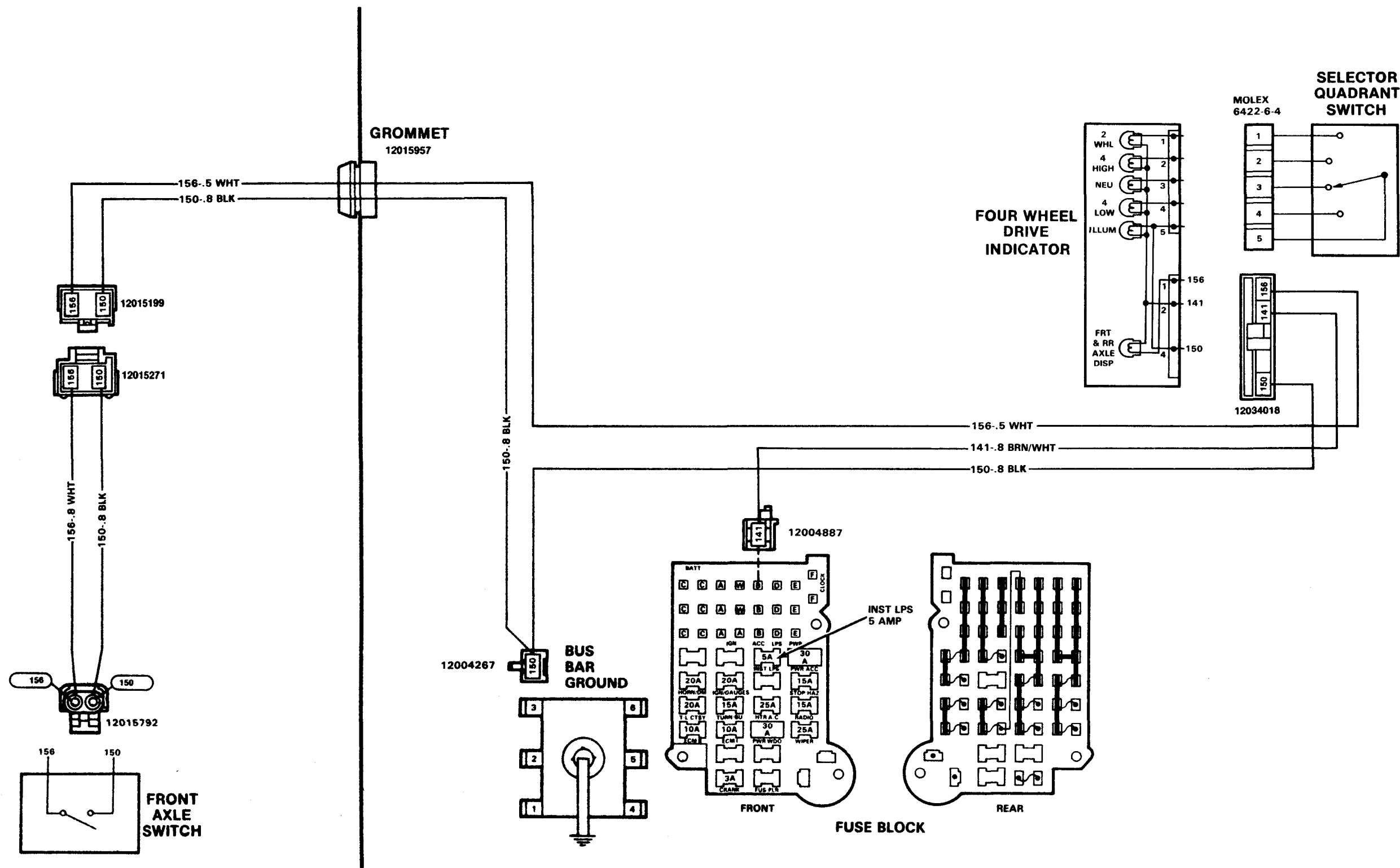

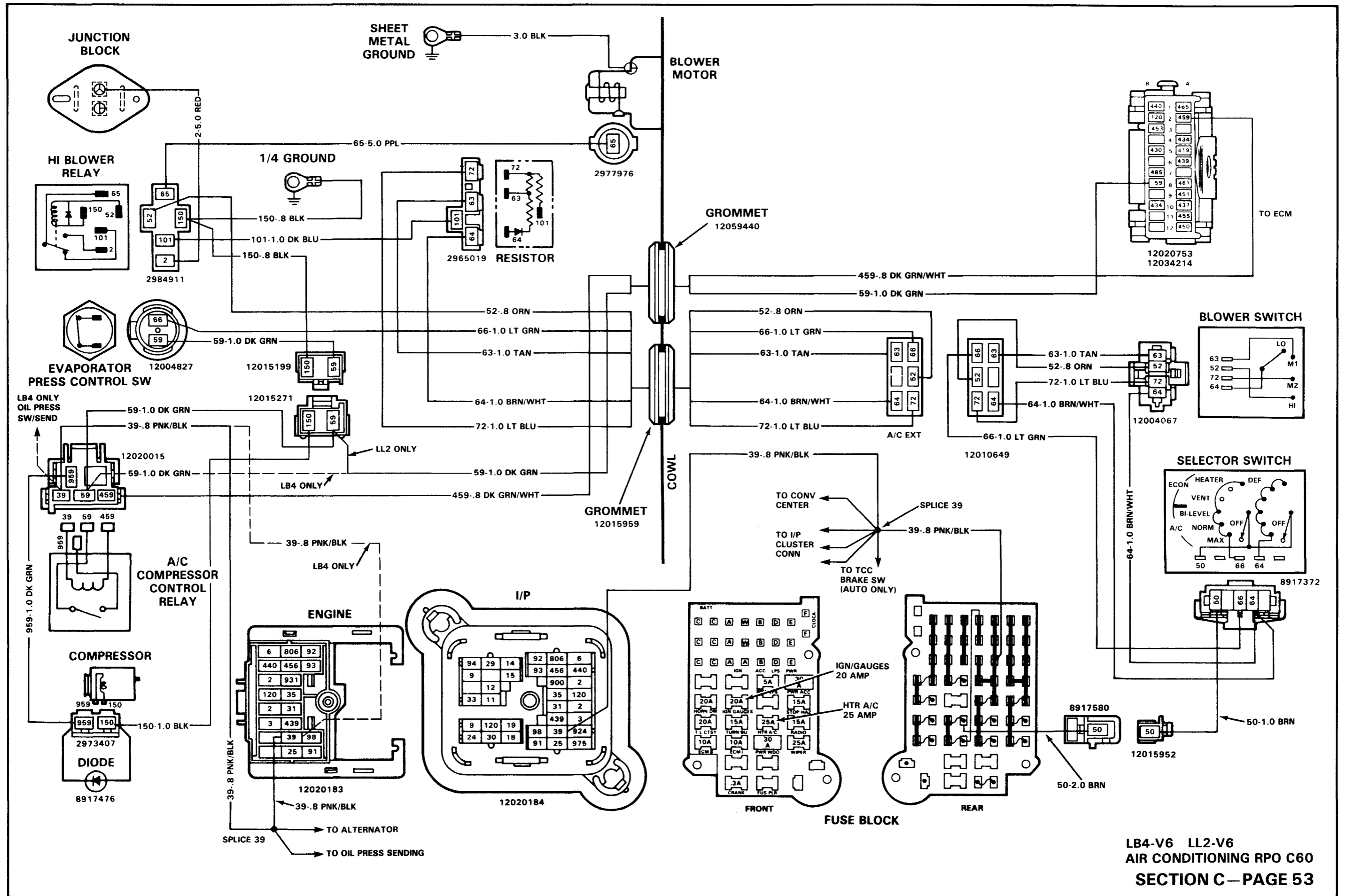

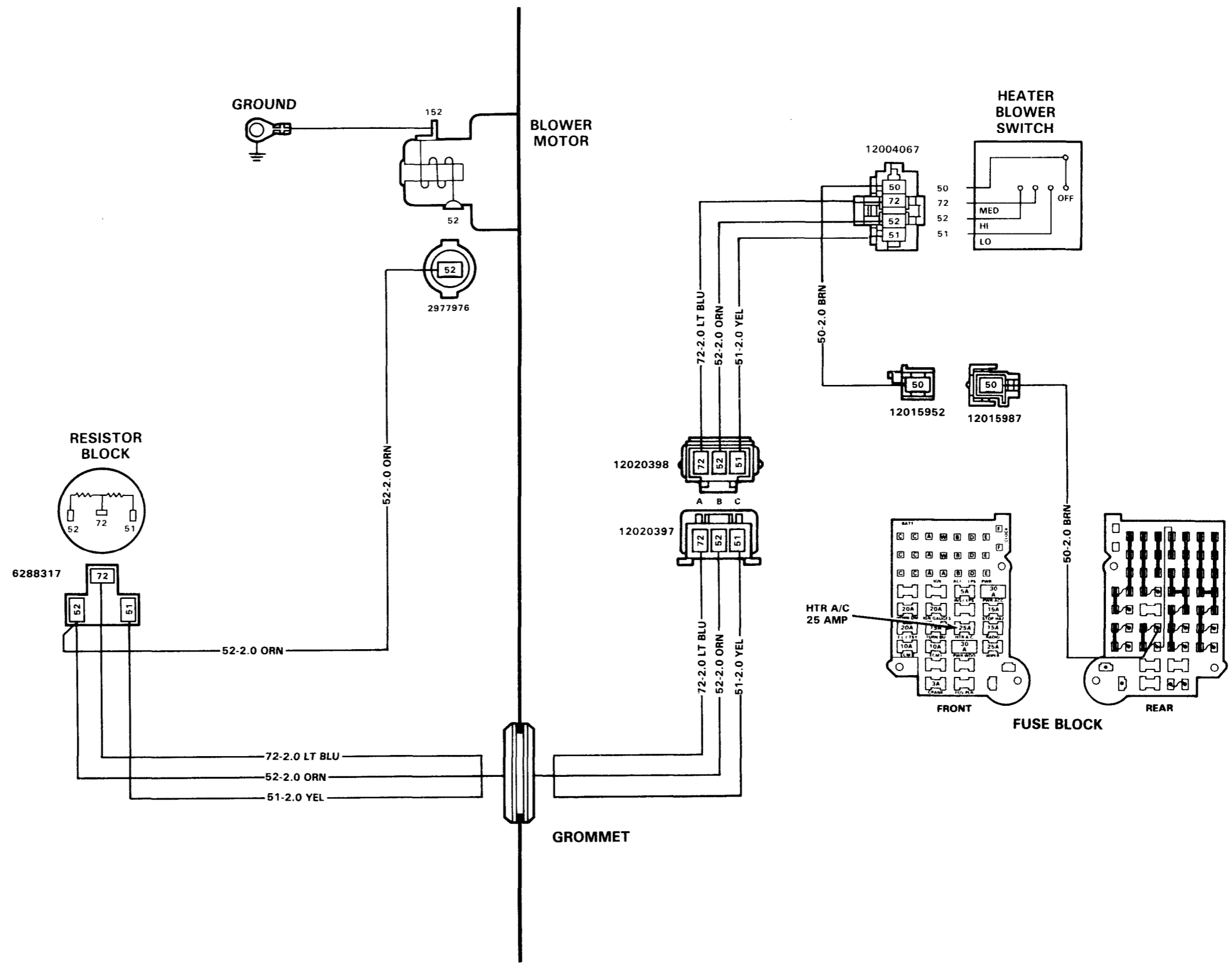

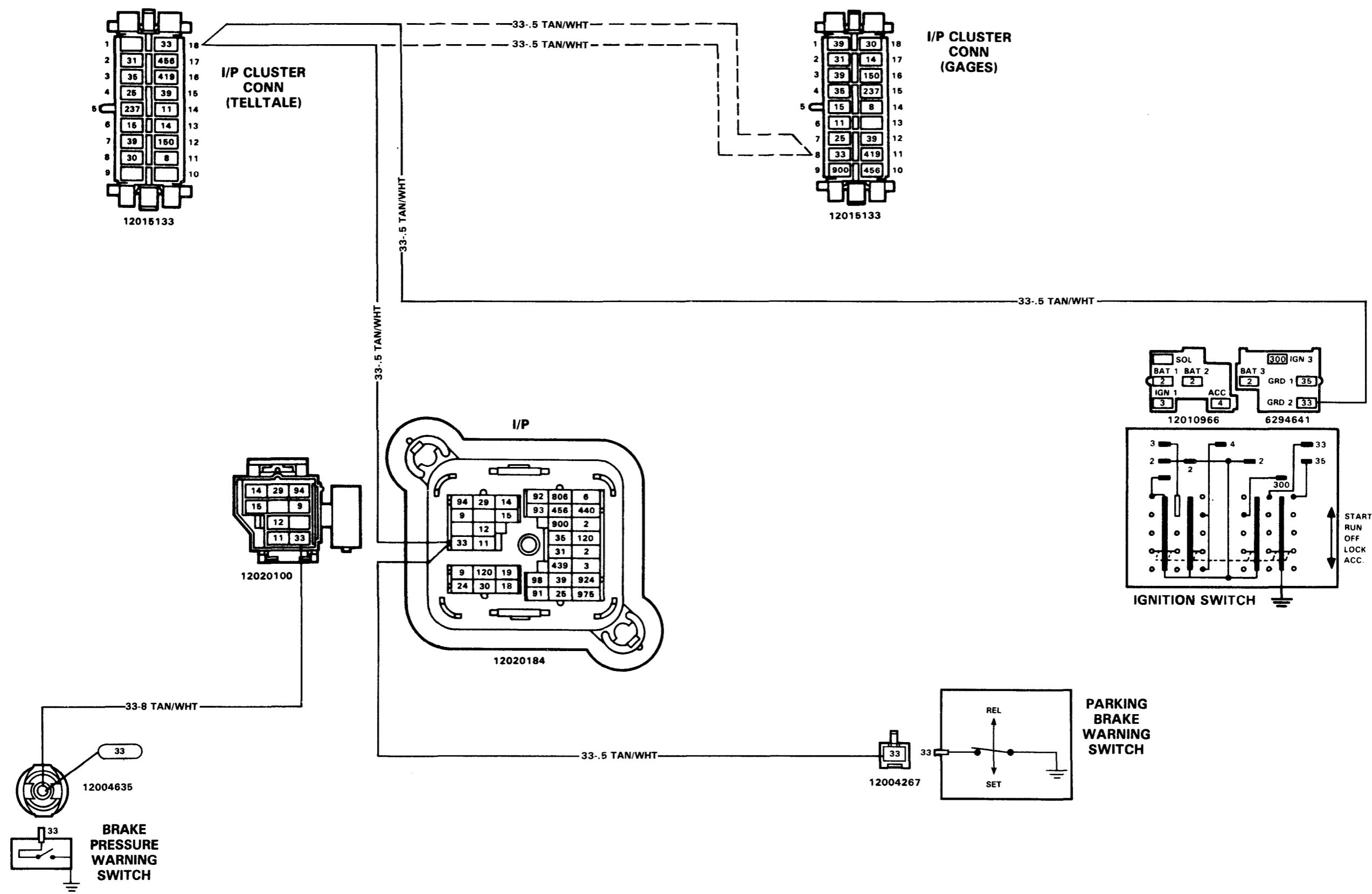

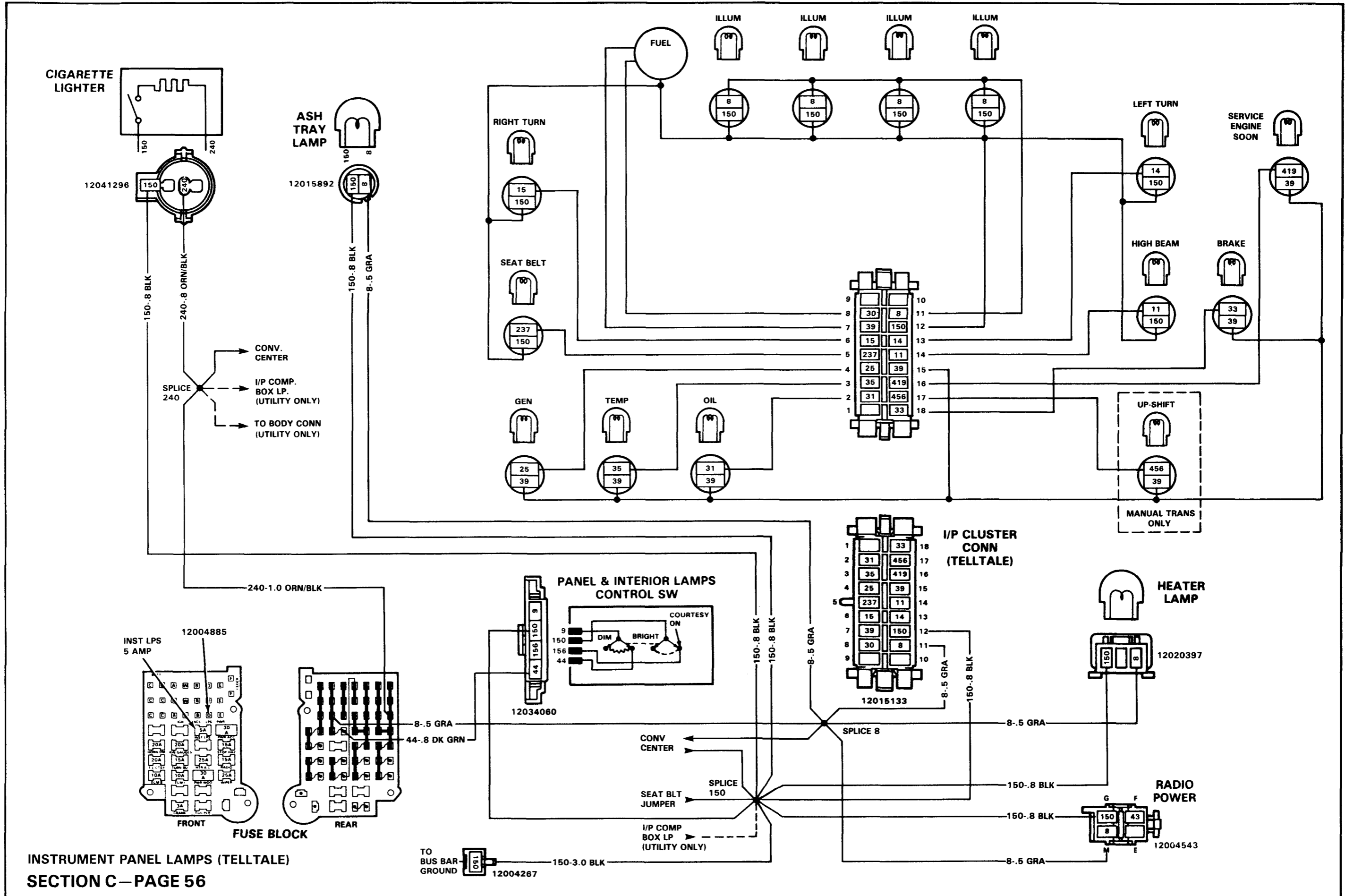

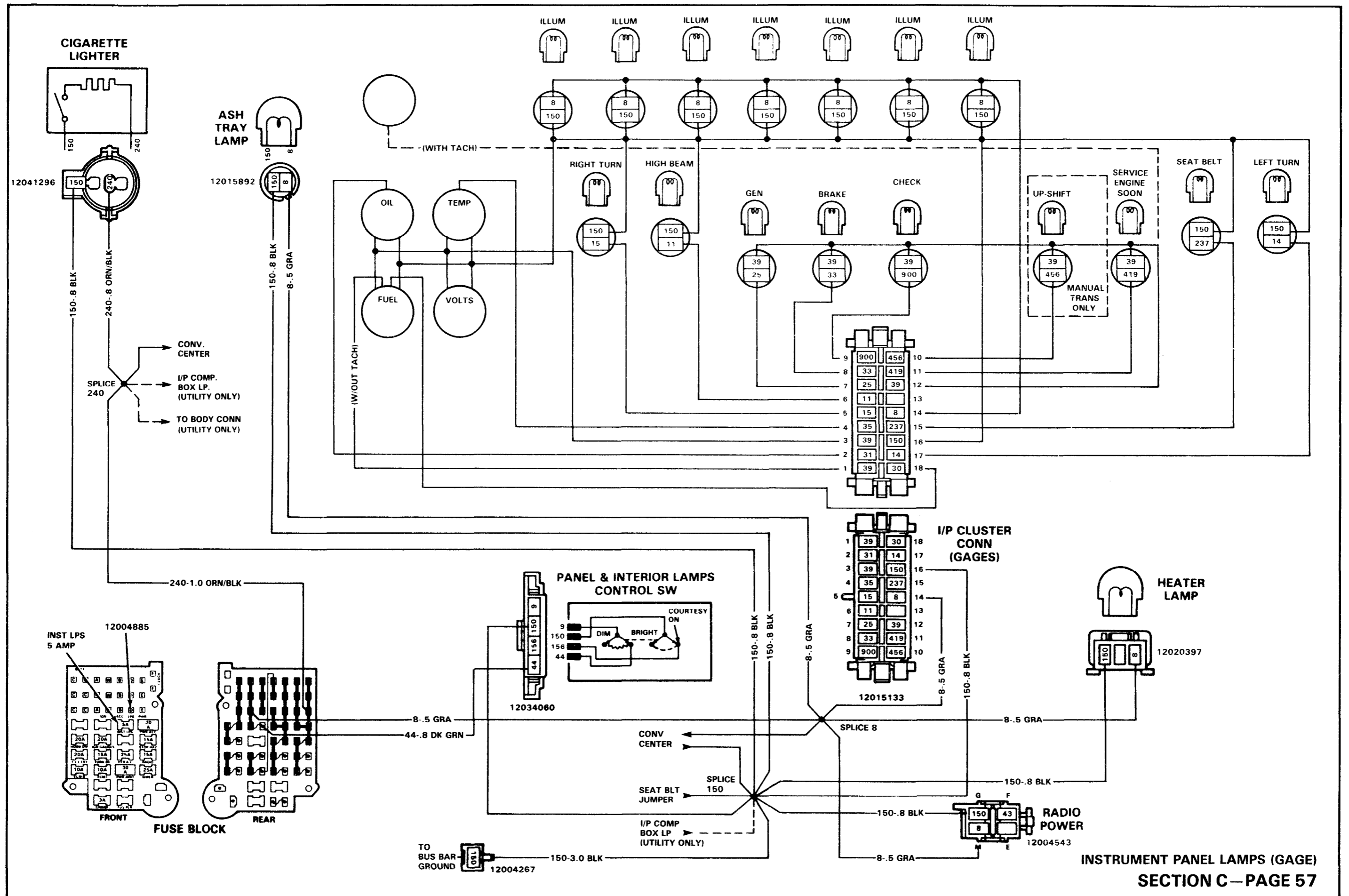

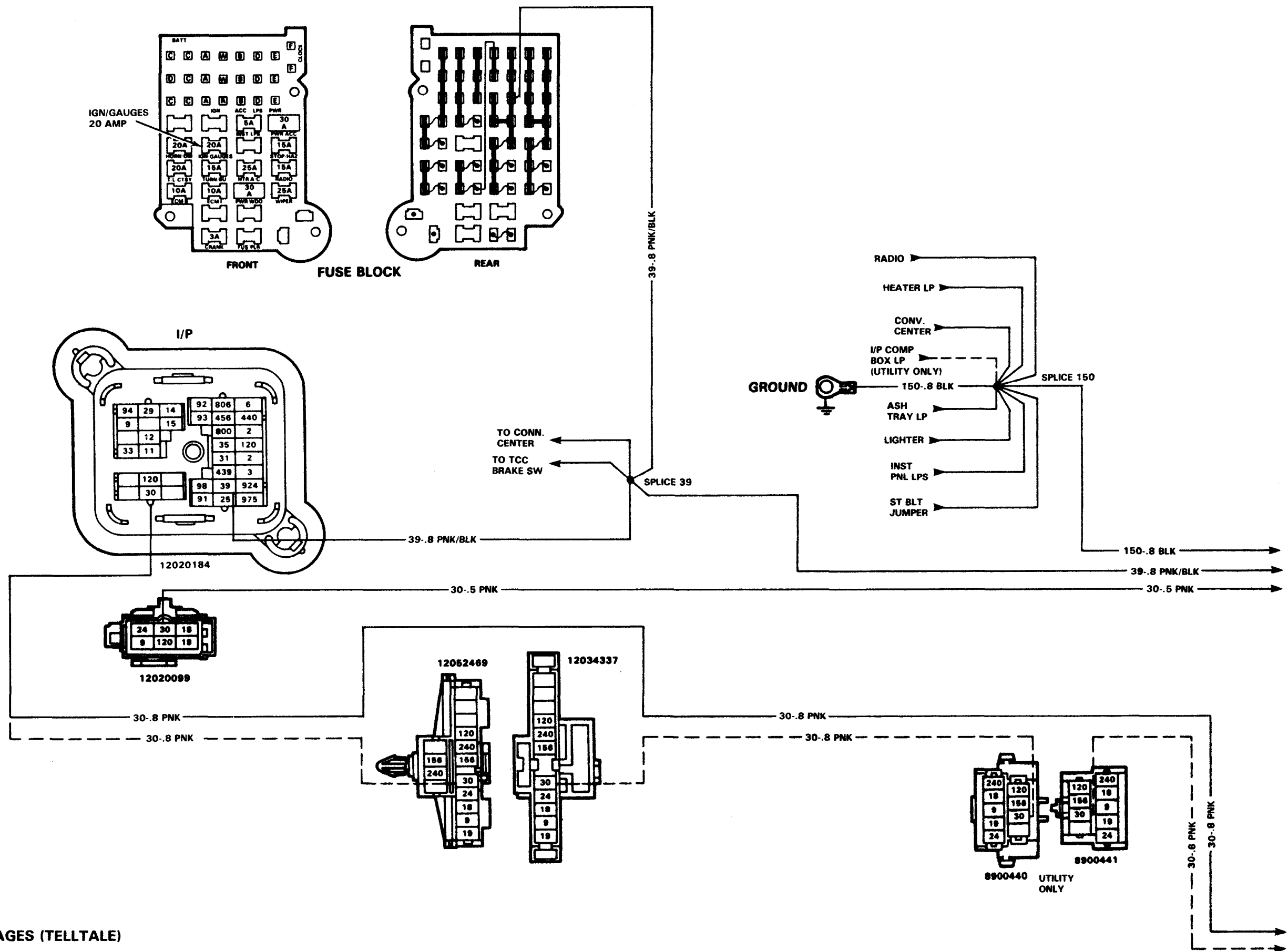

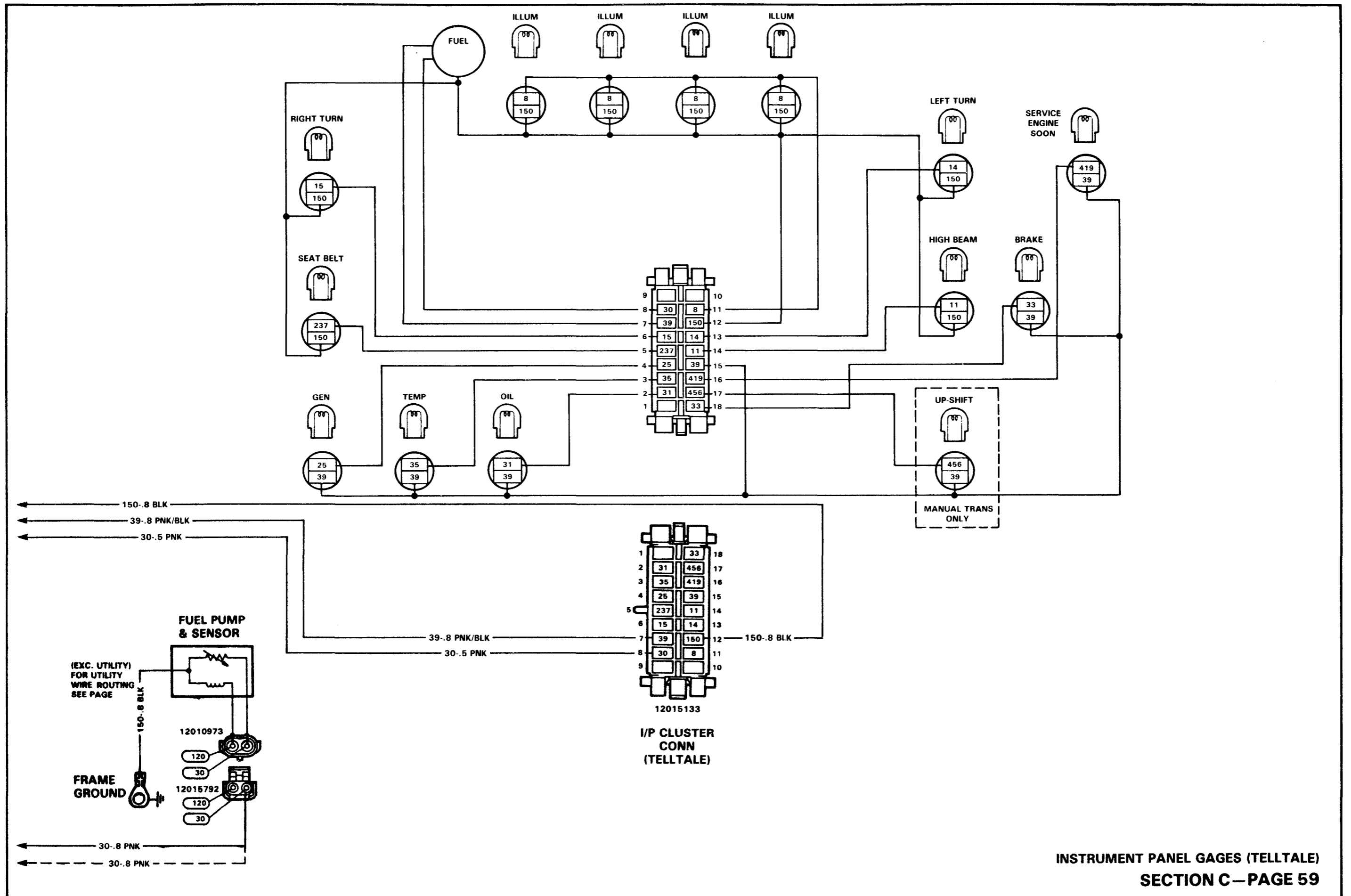

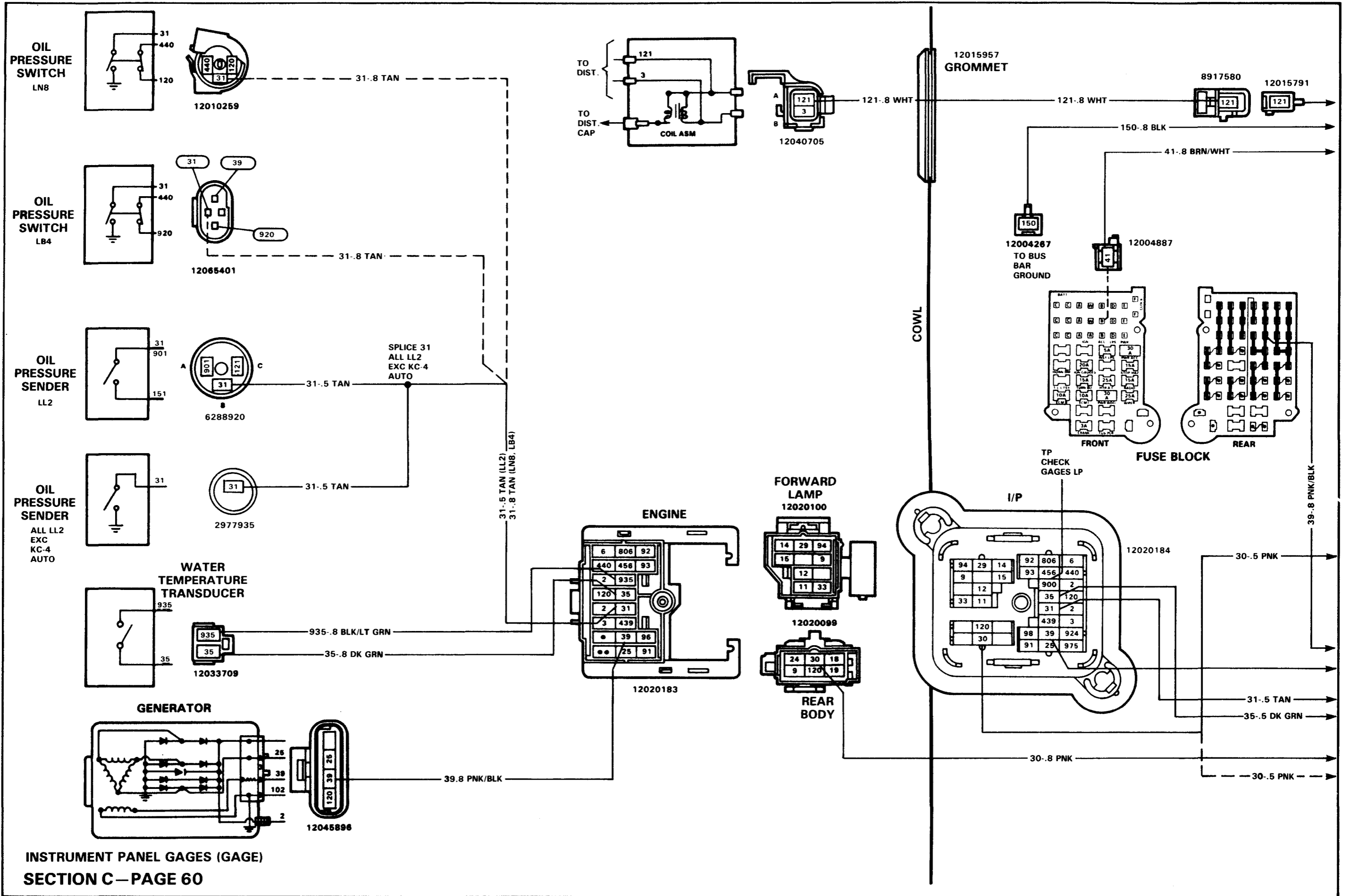

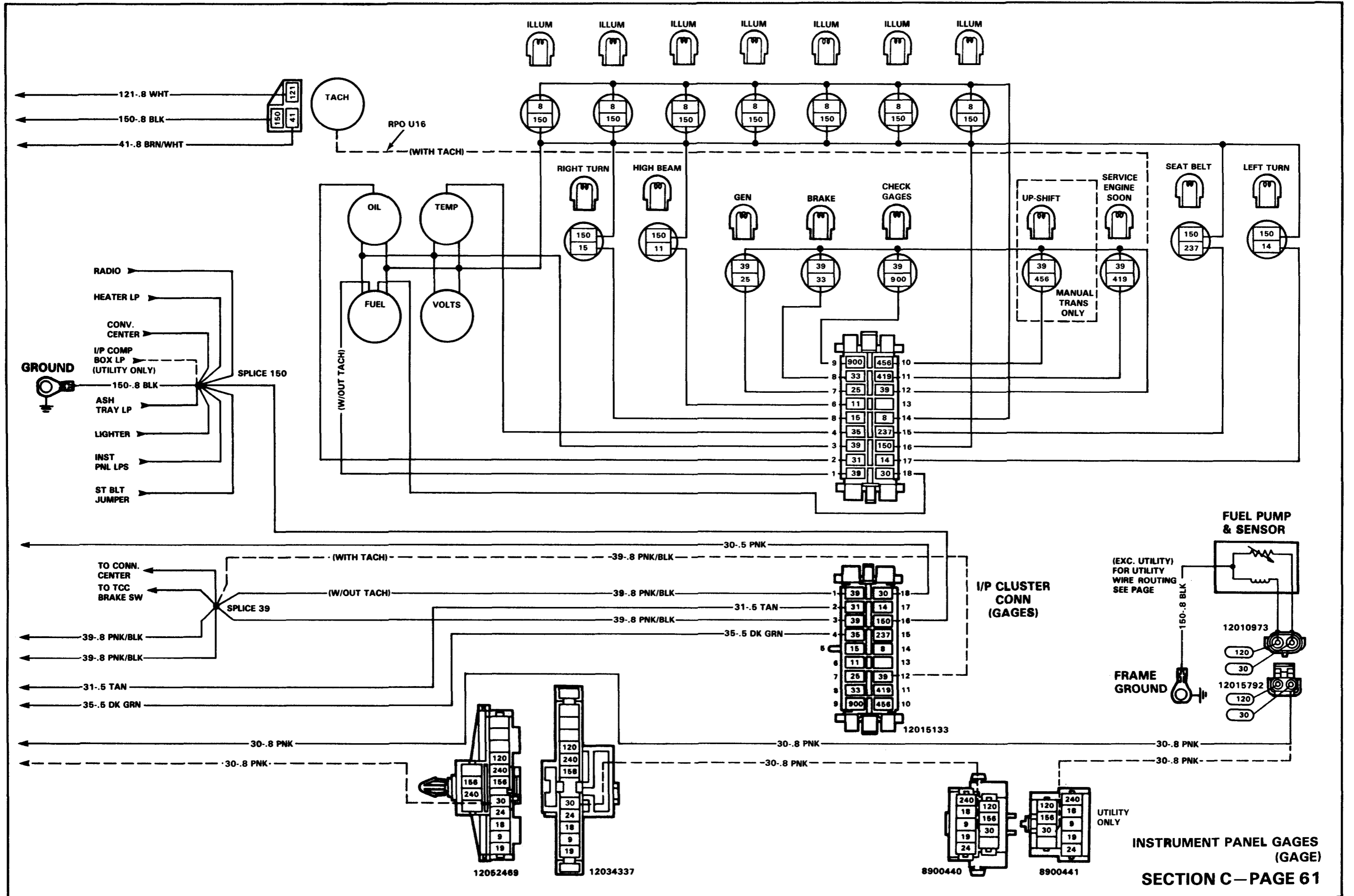

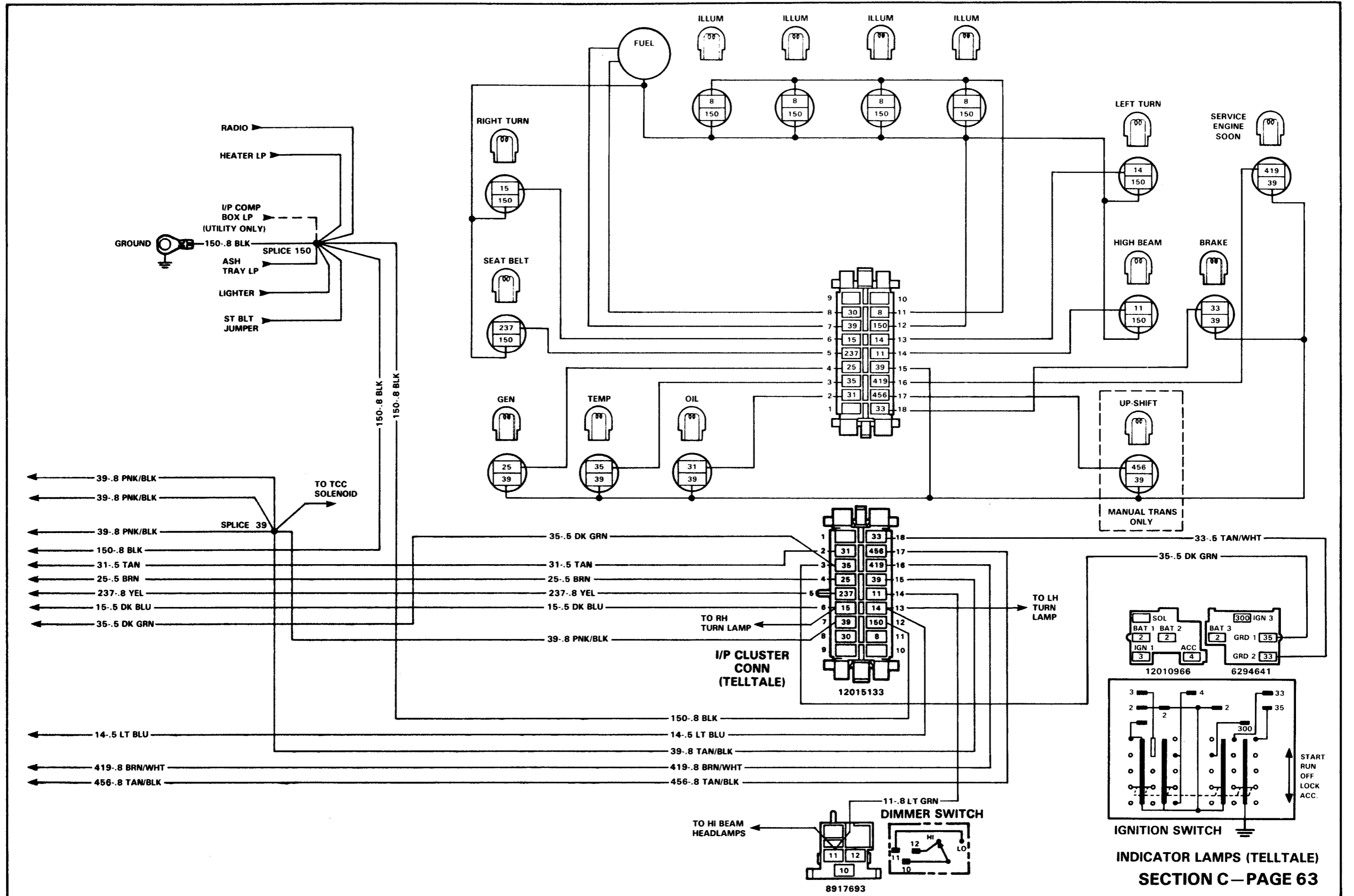

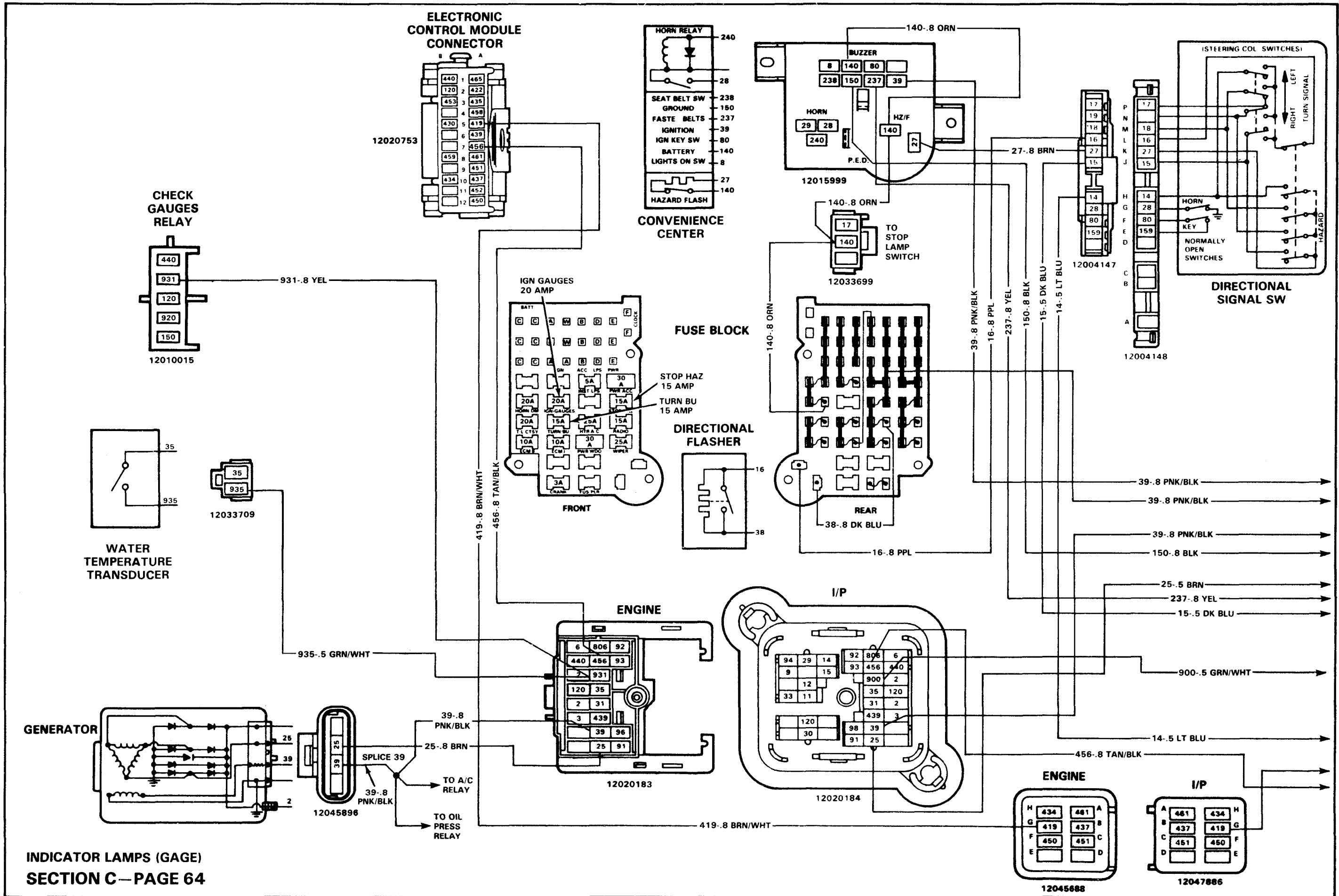

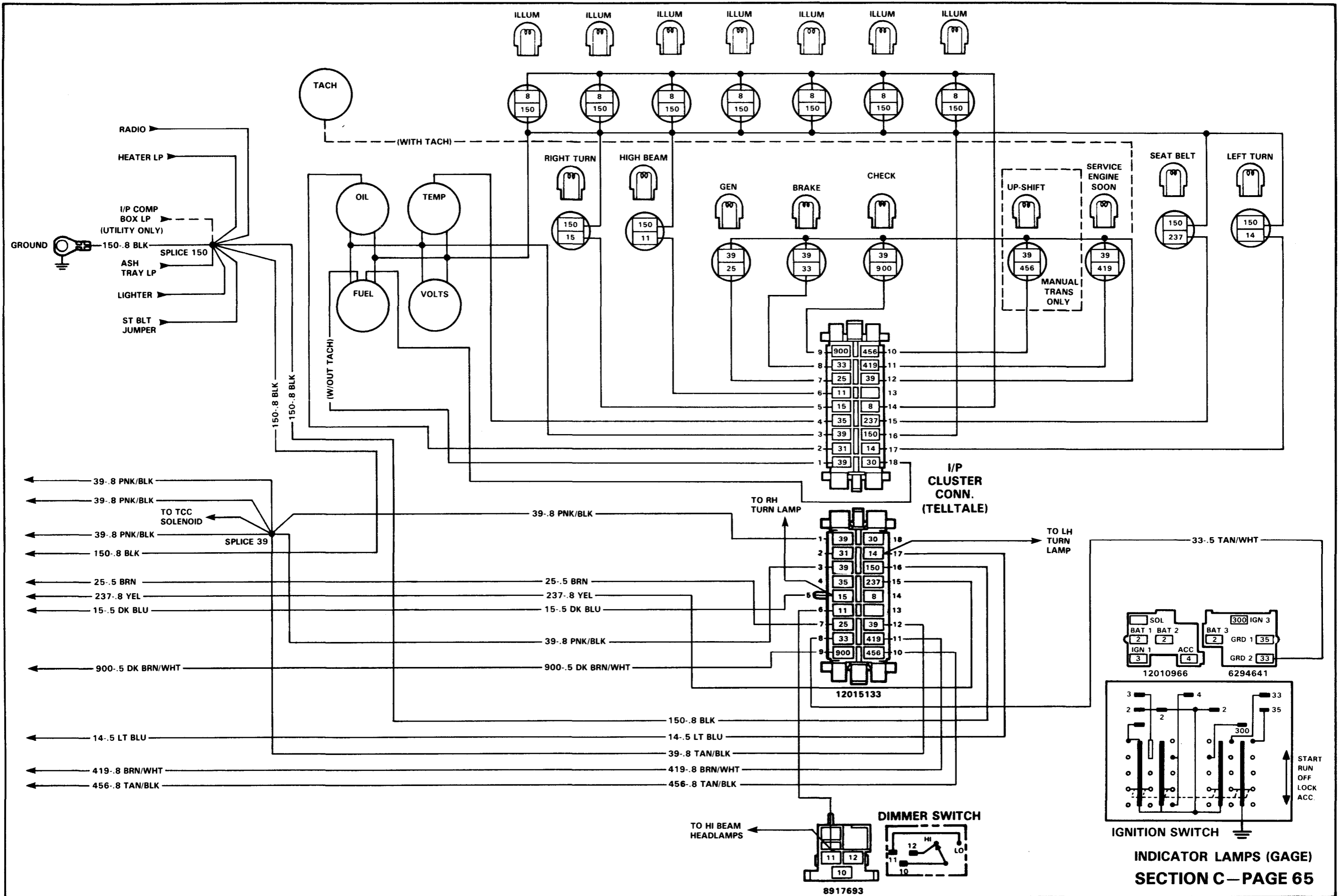

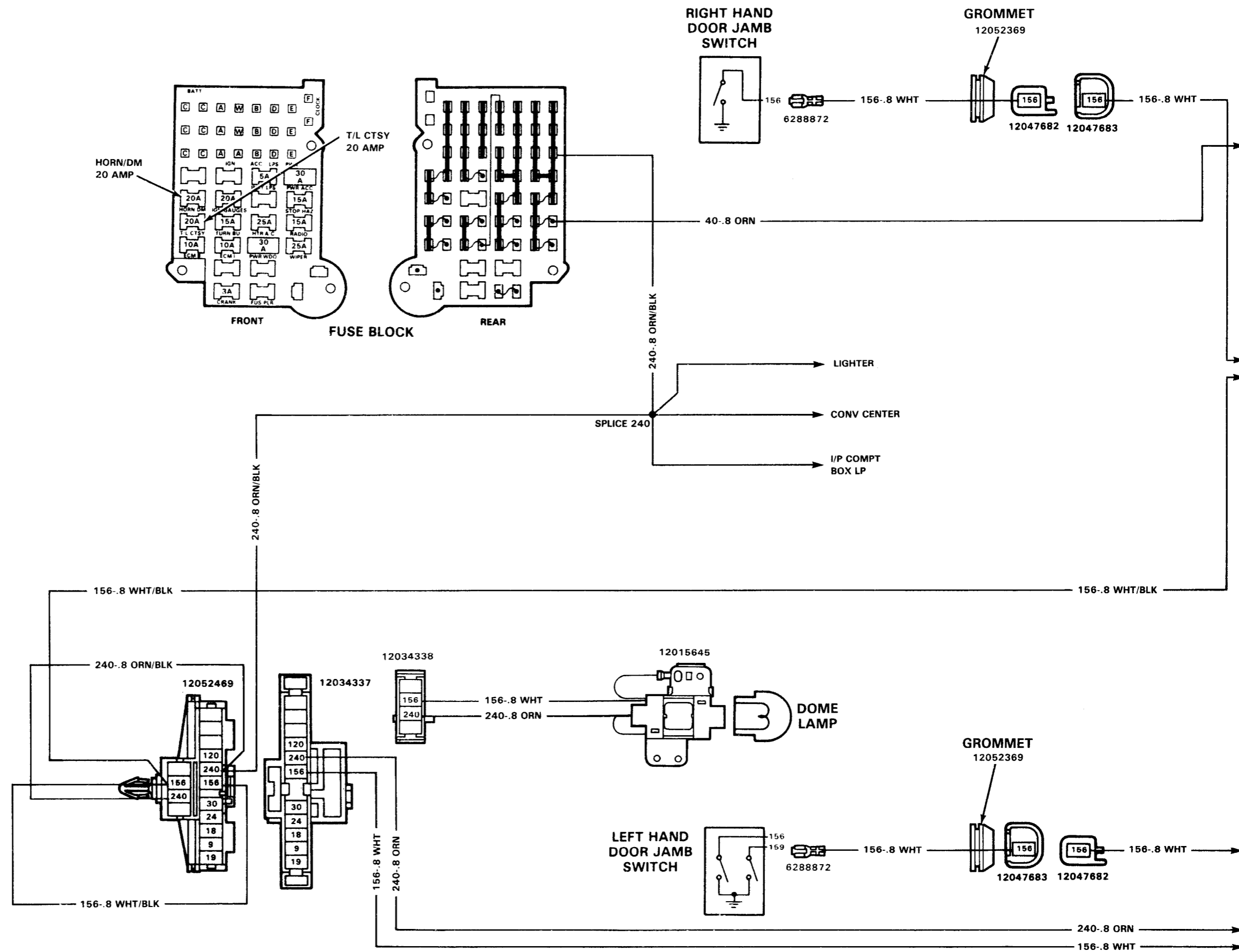

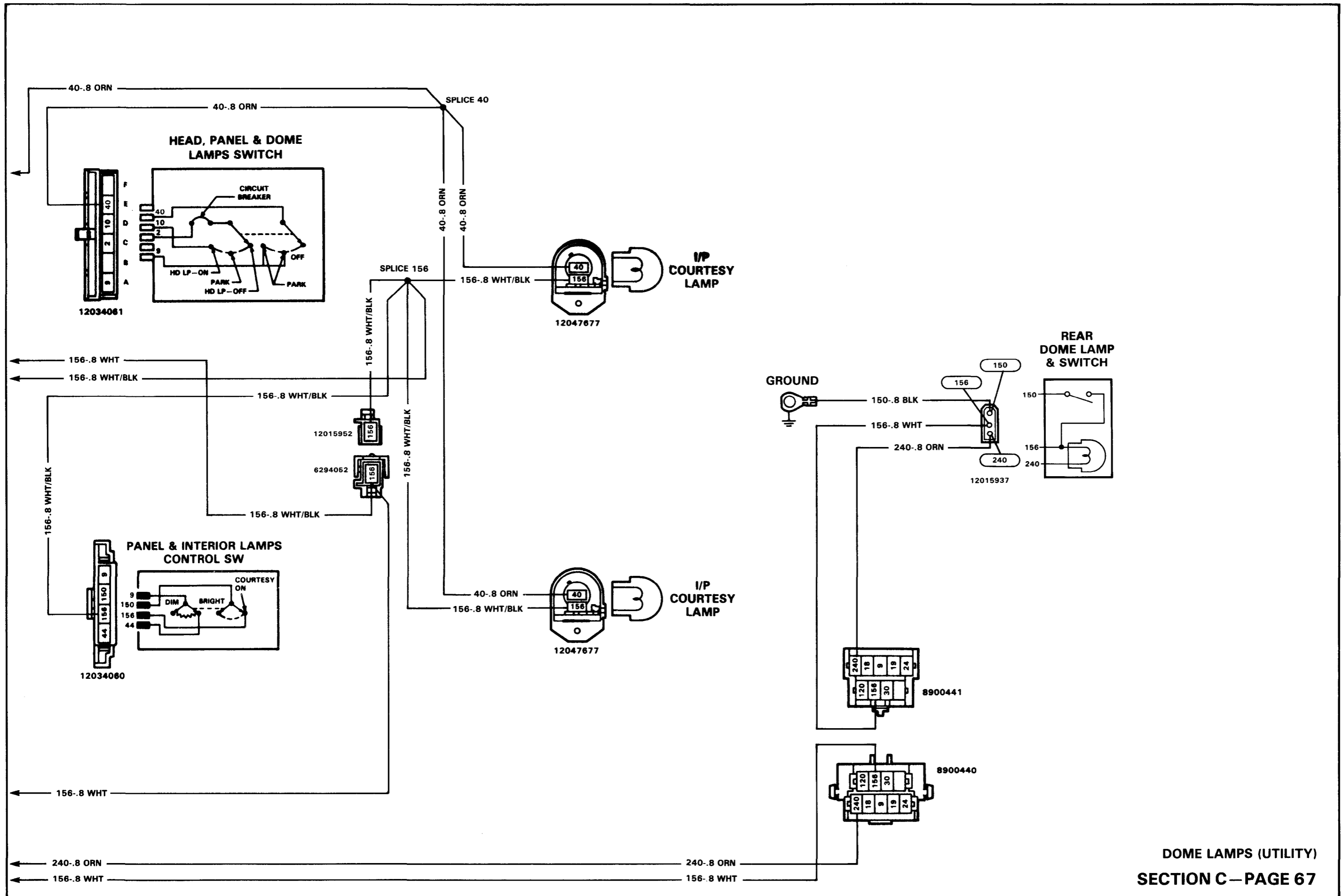

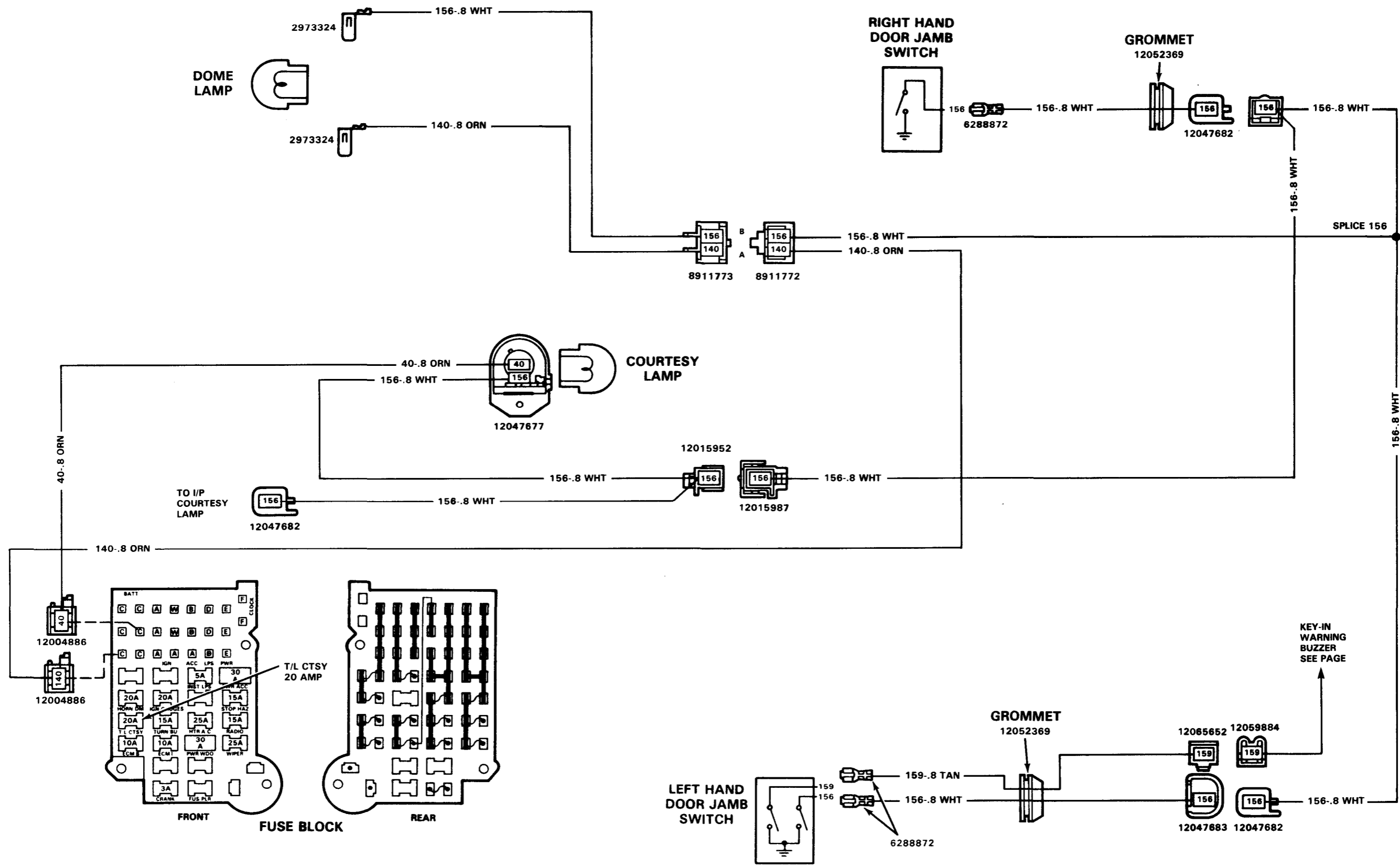

DOME LAMP (RPO C91) (03-53 MODELS)
SECTION C—PAGE 68

CONVENIENCE CENTER

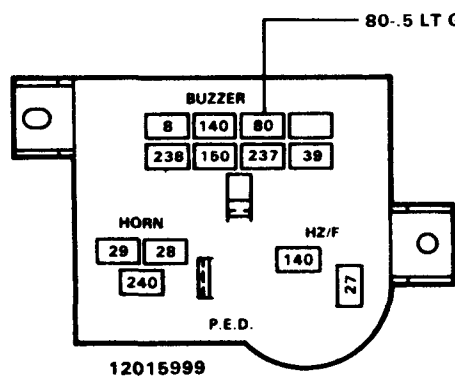
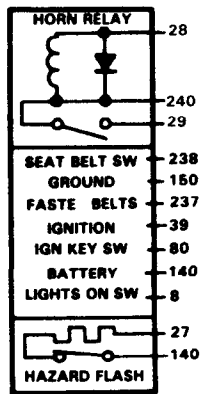

KEY-IN WARNING BUZZER

LEFT HAND DOOR JAMB SWITCH

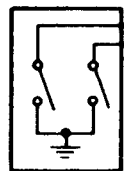

GROMMET

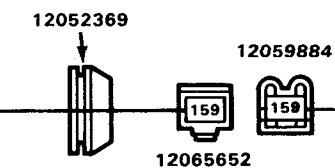

(STEERING COL. SWITCHES)

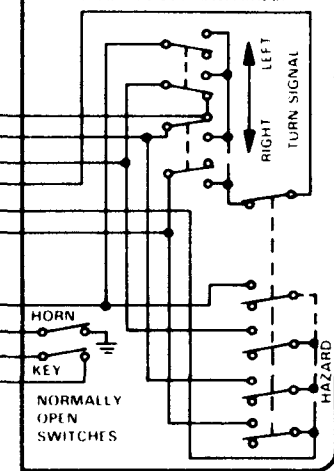

DIRECTIONAL SIGNAL SW

12004148

HEAD, PANEL & DOME LAMPS SWITCH

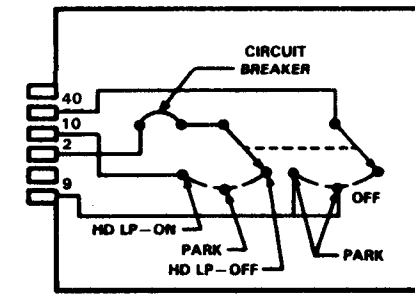

12034061

PANEL & INTERIOR LAMPS CONTROL SW

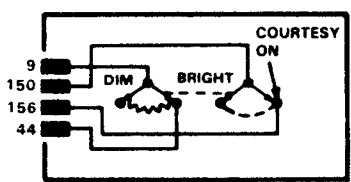

12034080

I/P COURTESY LAMP

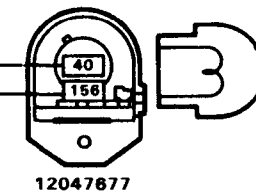

12047677

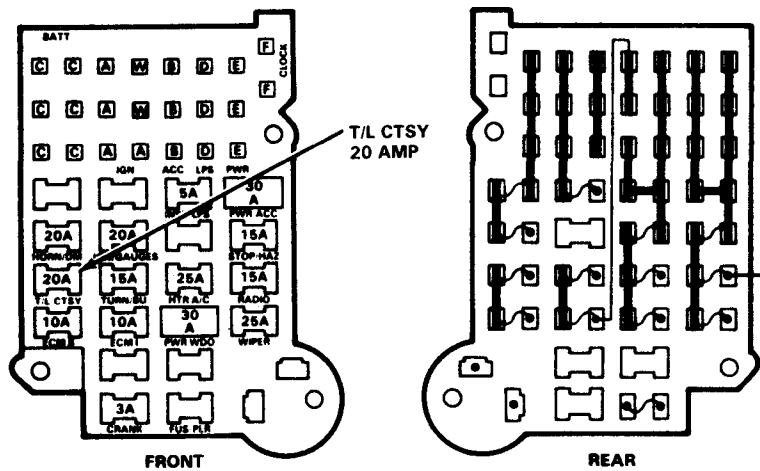

FUSE BLOCK

INSTRUMENT PANEL COURTESY LAMP (03-53 MODELS)

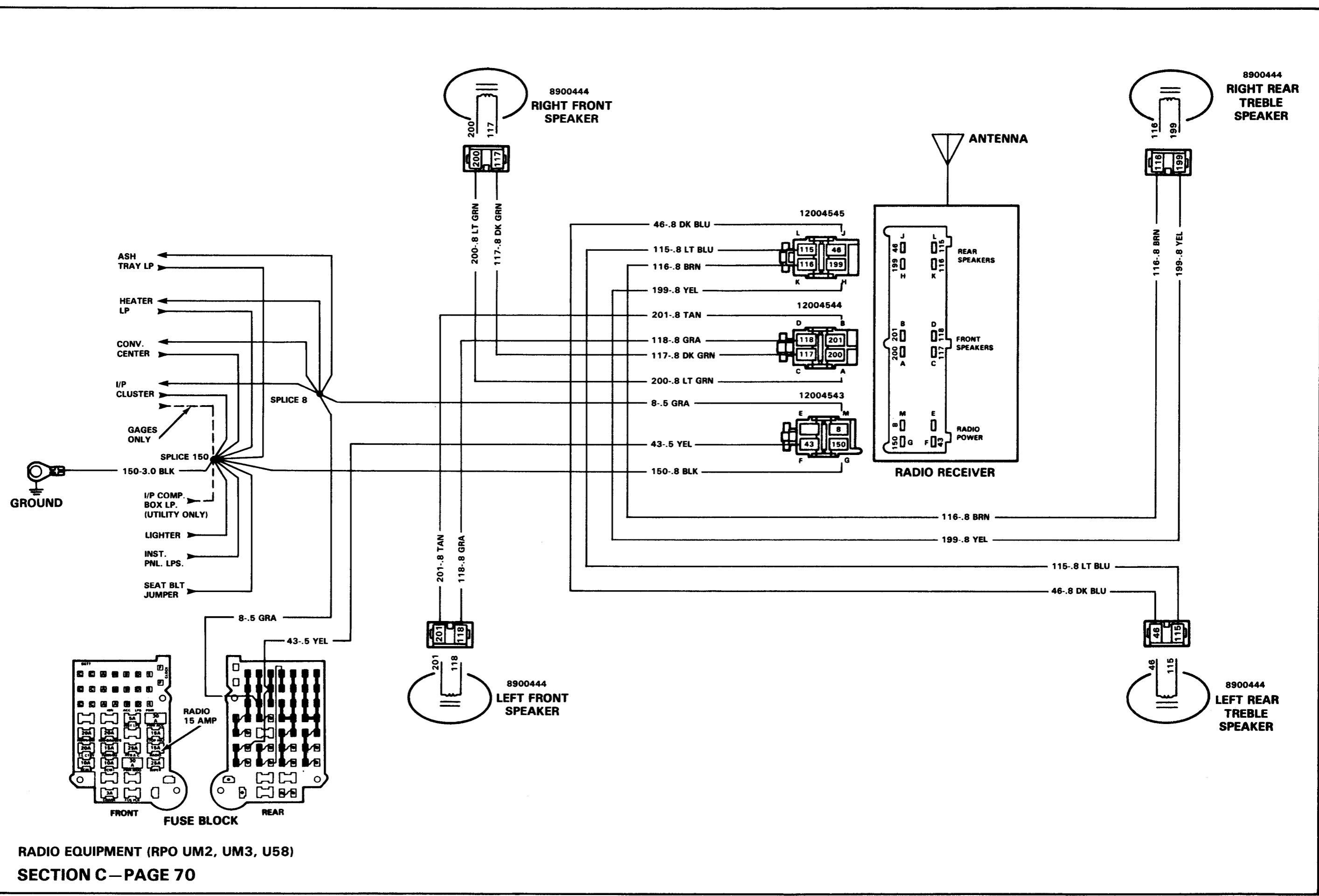

RADIO EQUIPMENT (RPO UM2, UM3, U58)
SECTION C—PAGE 70

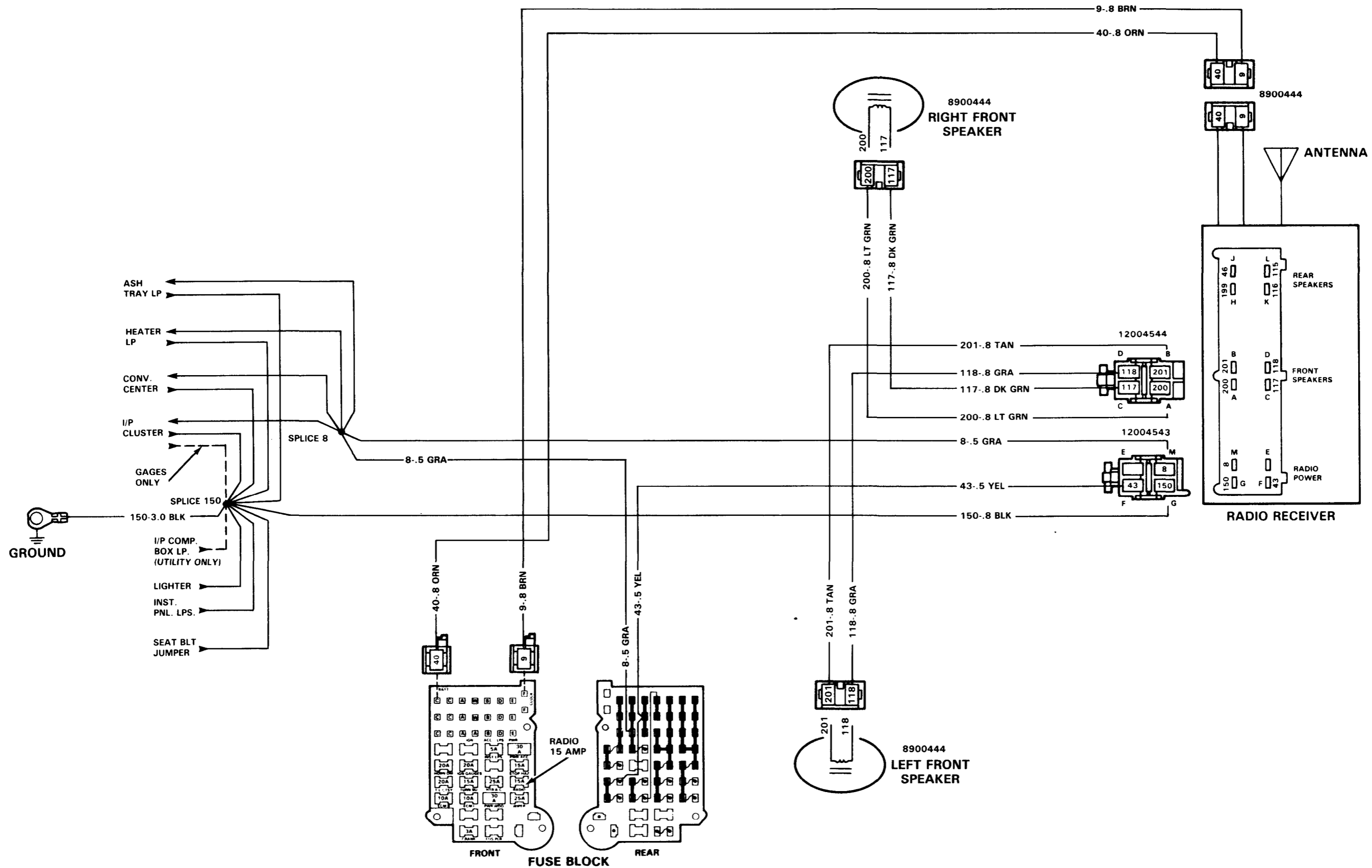

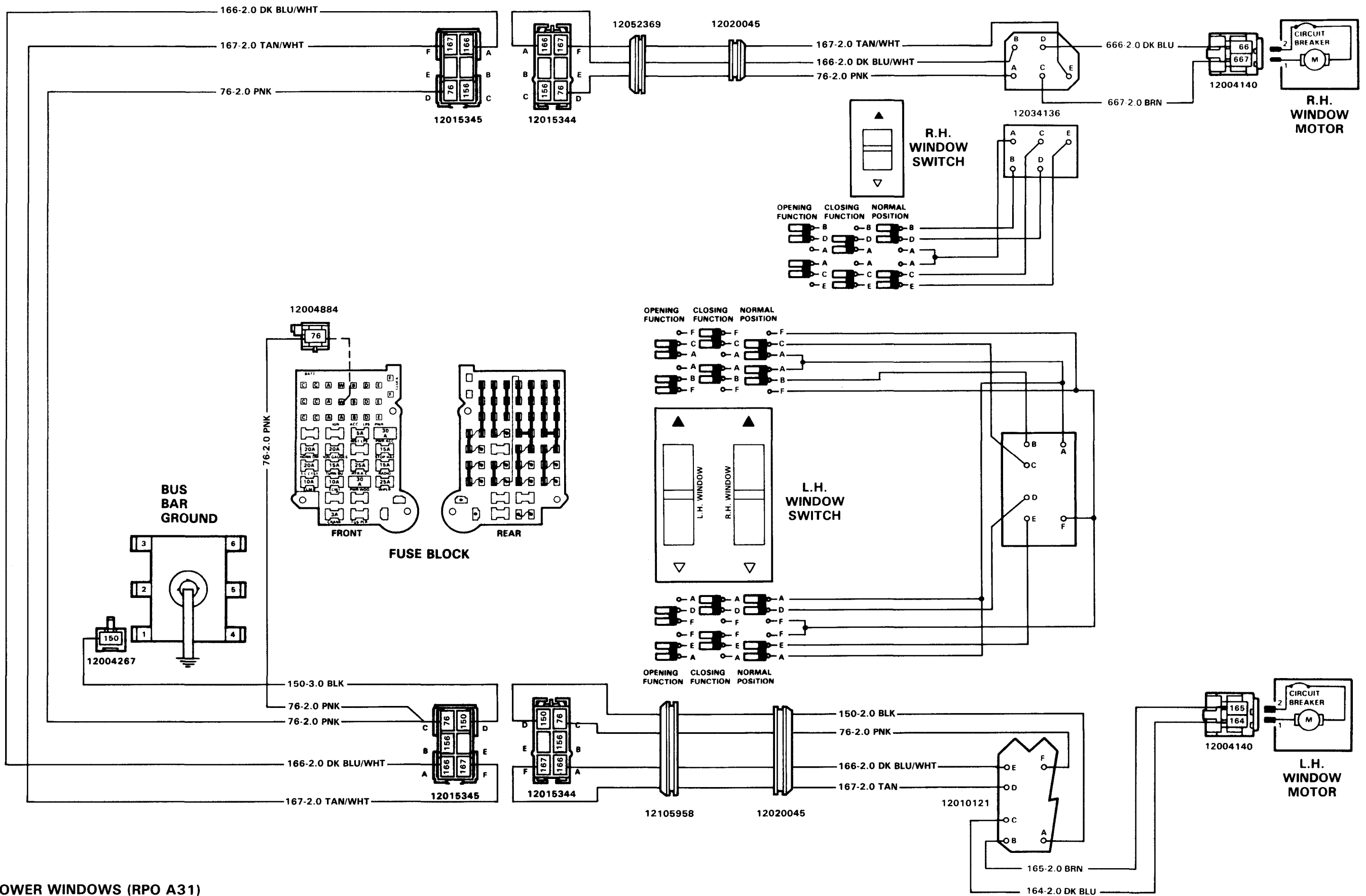

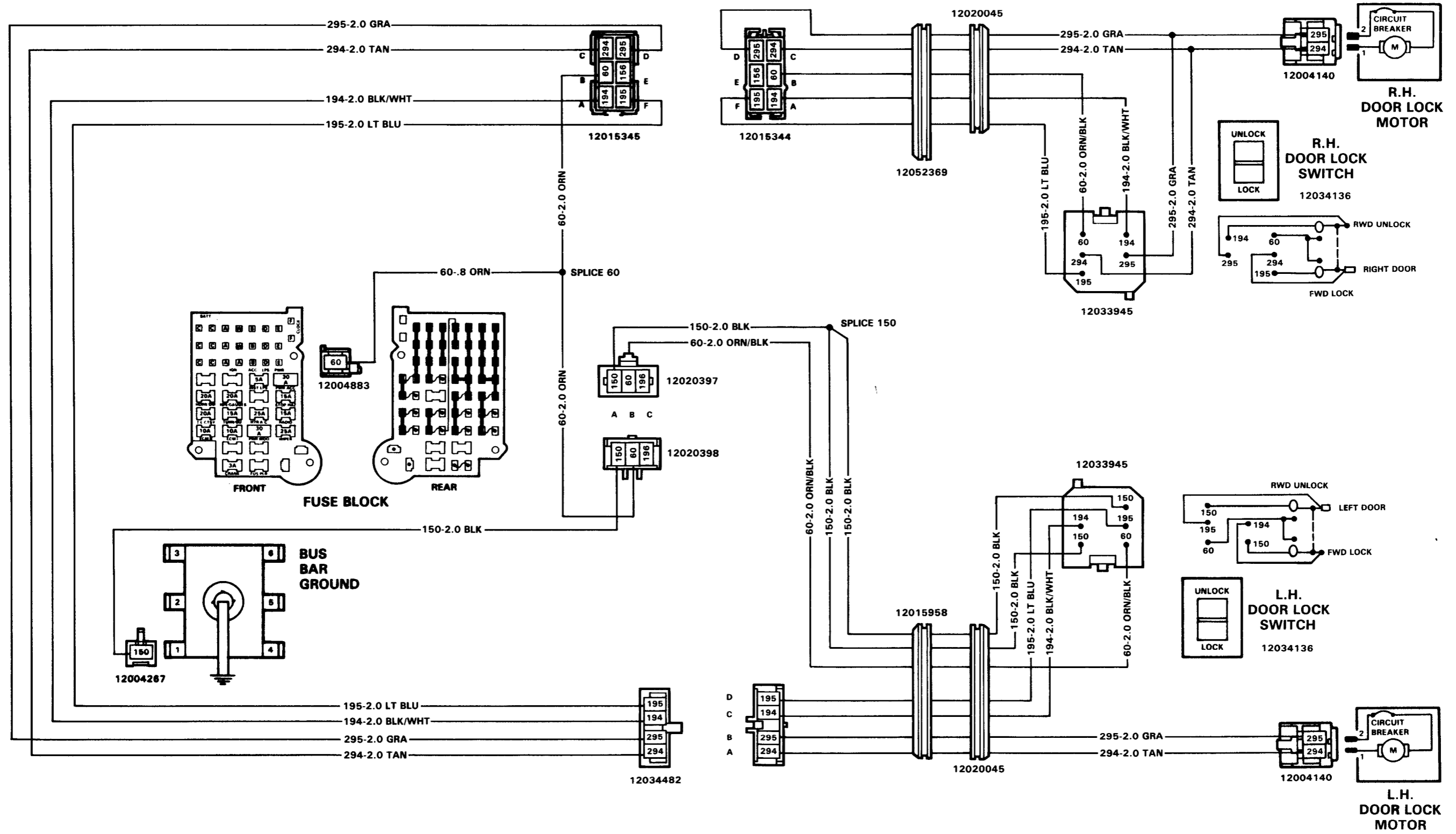

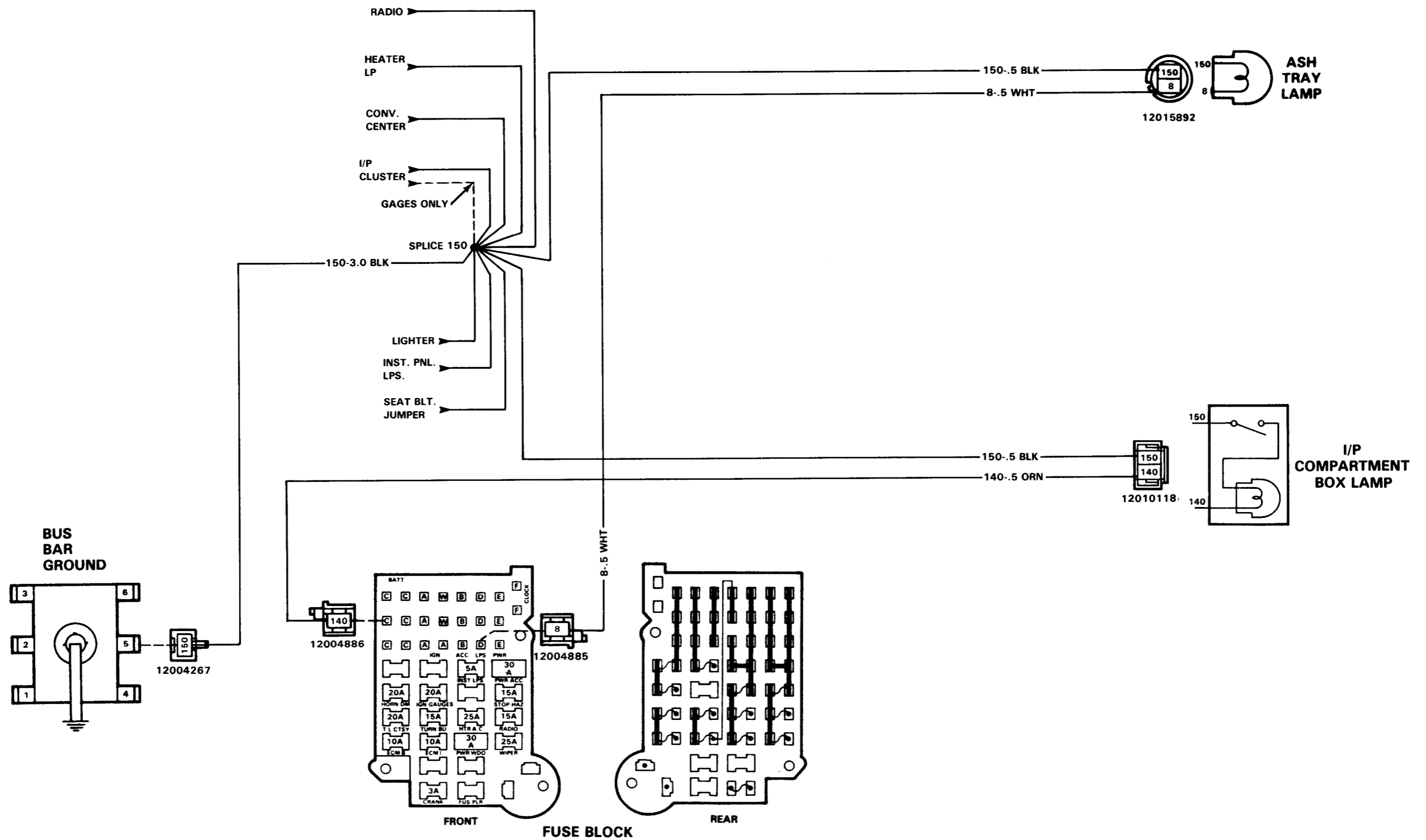

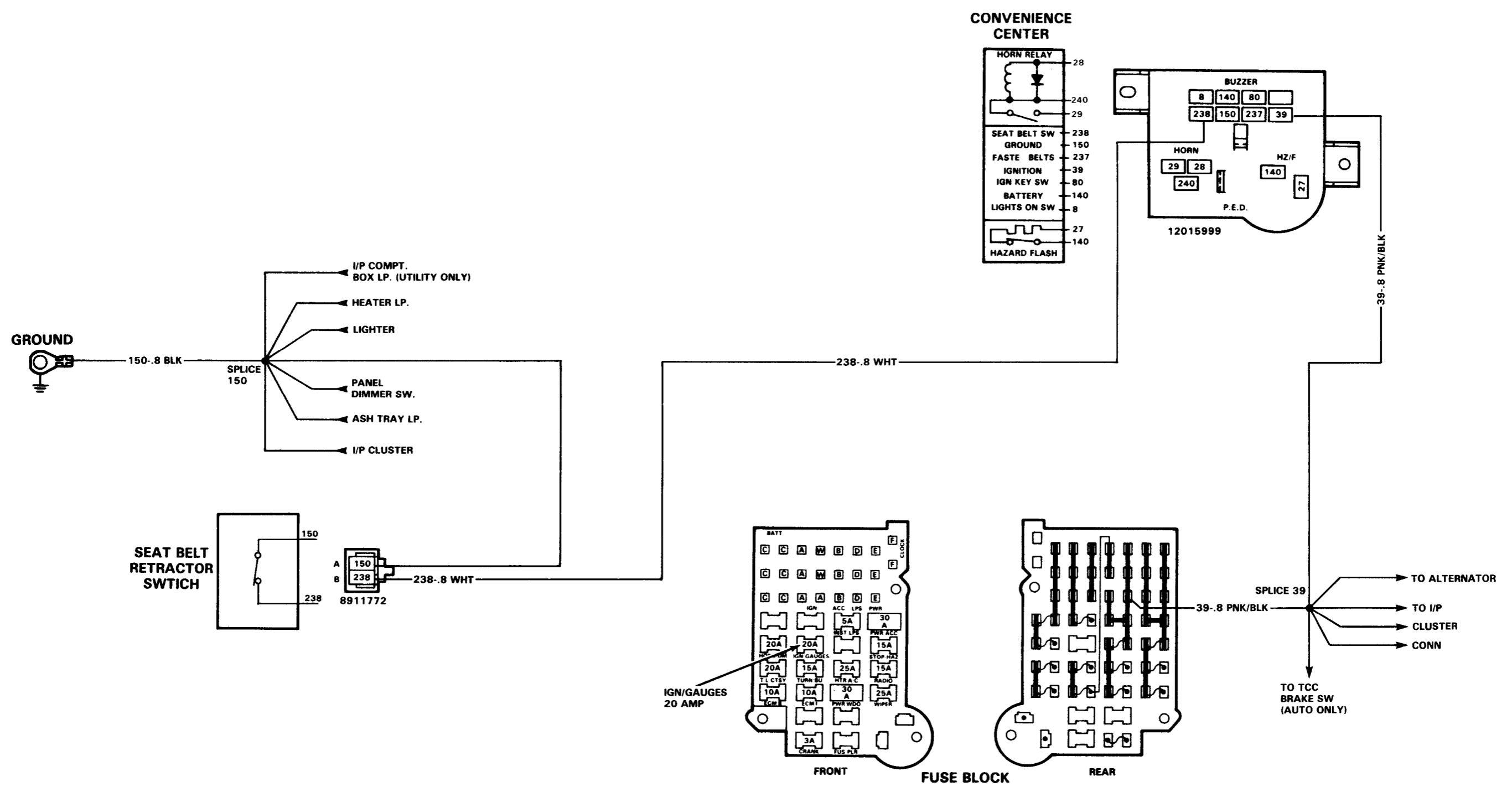

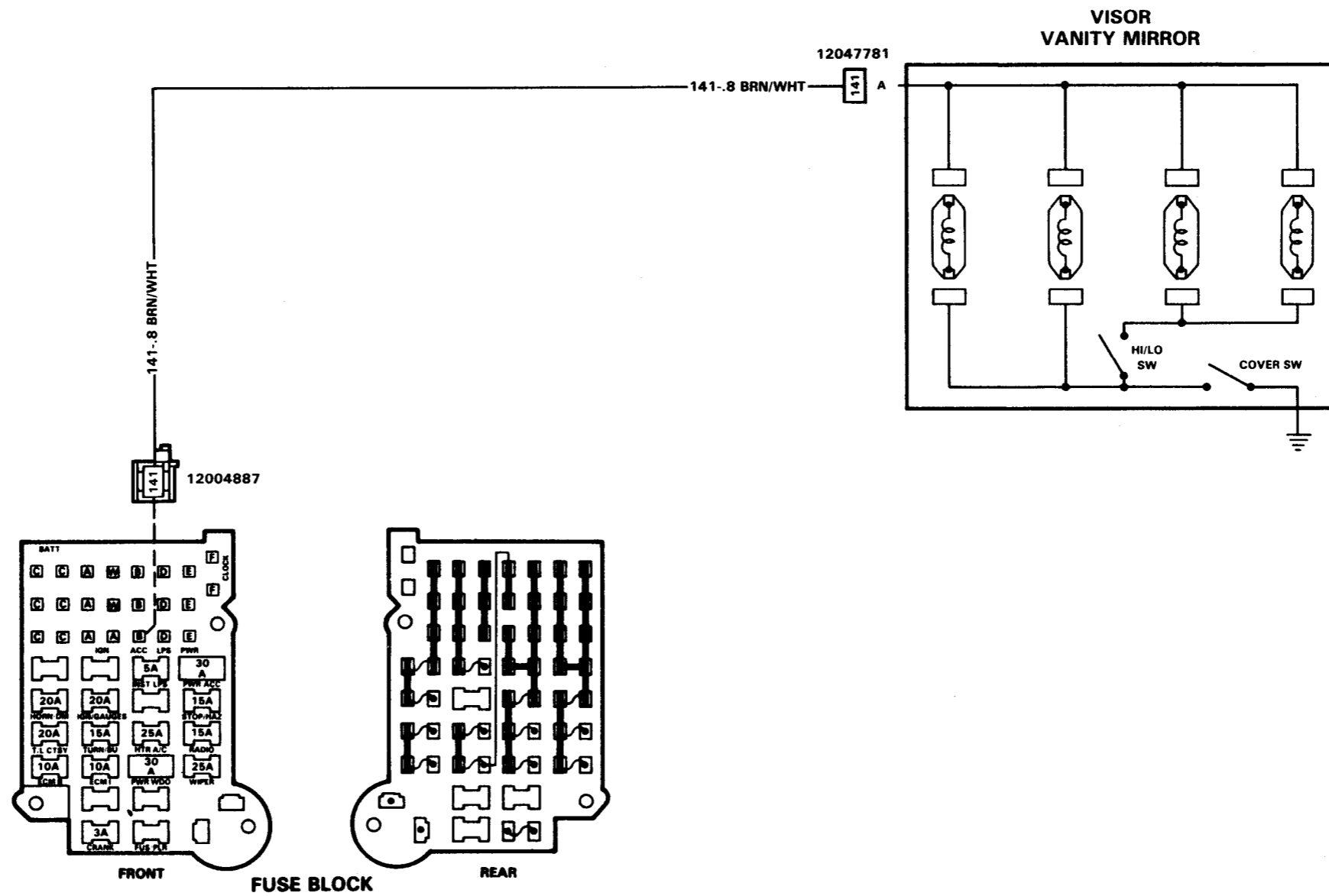

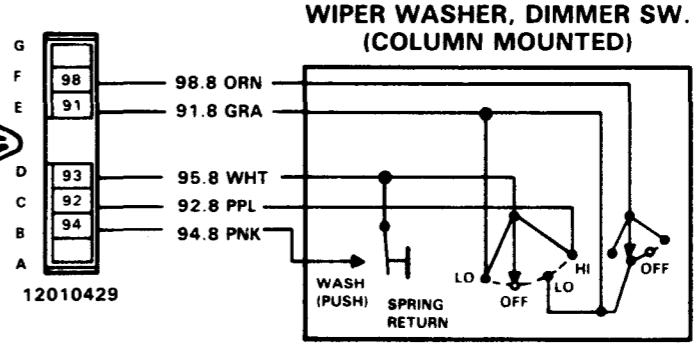
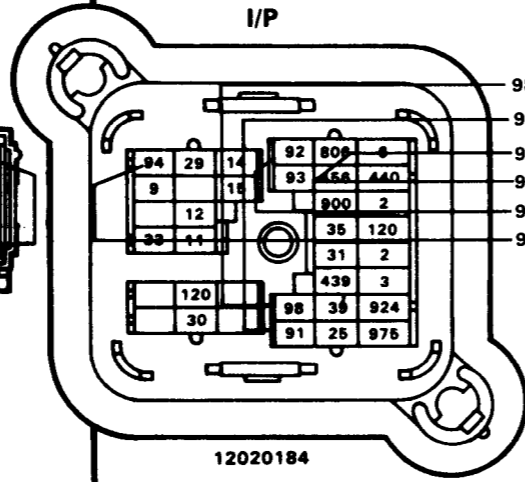
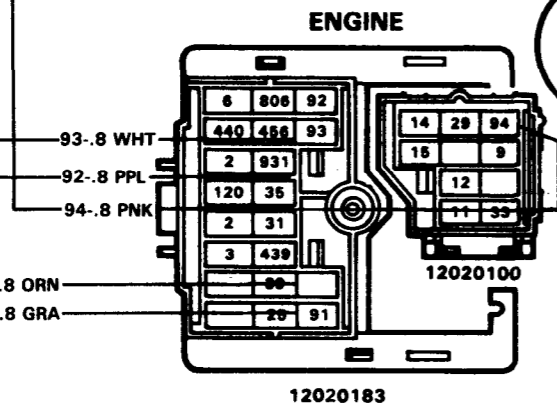
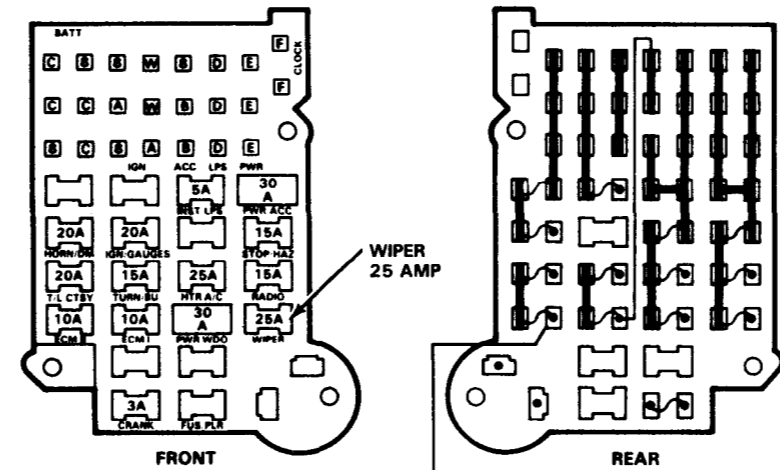
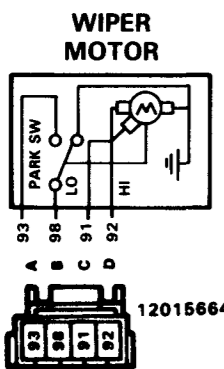
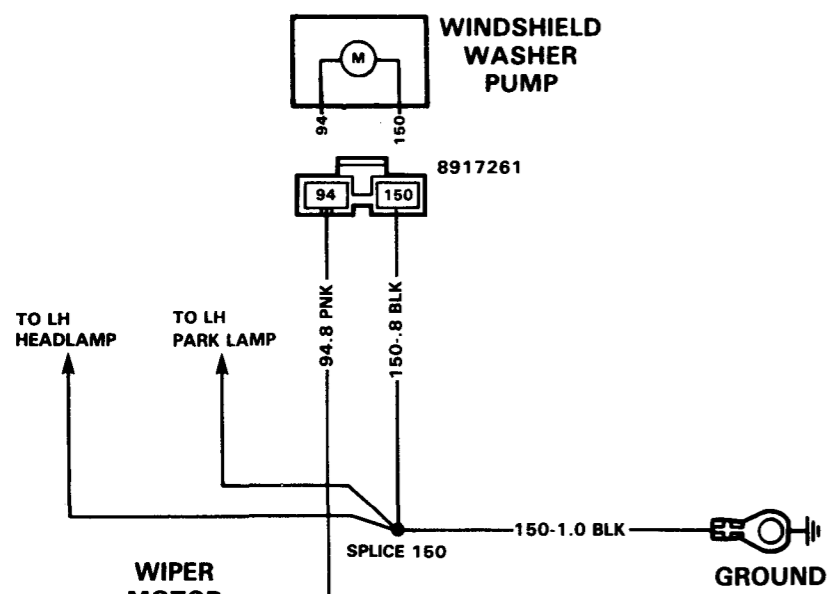

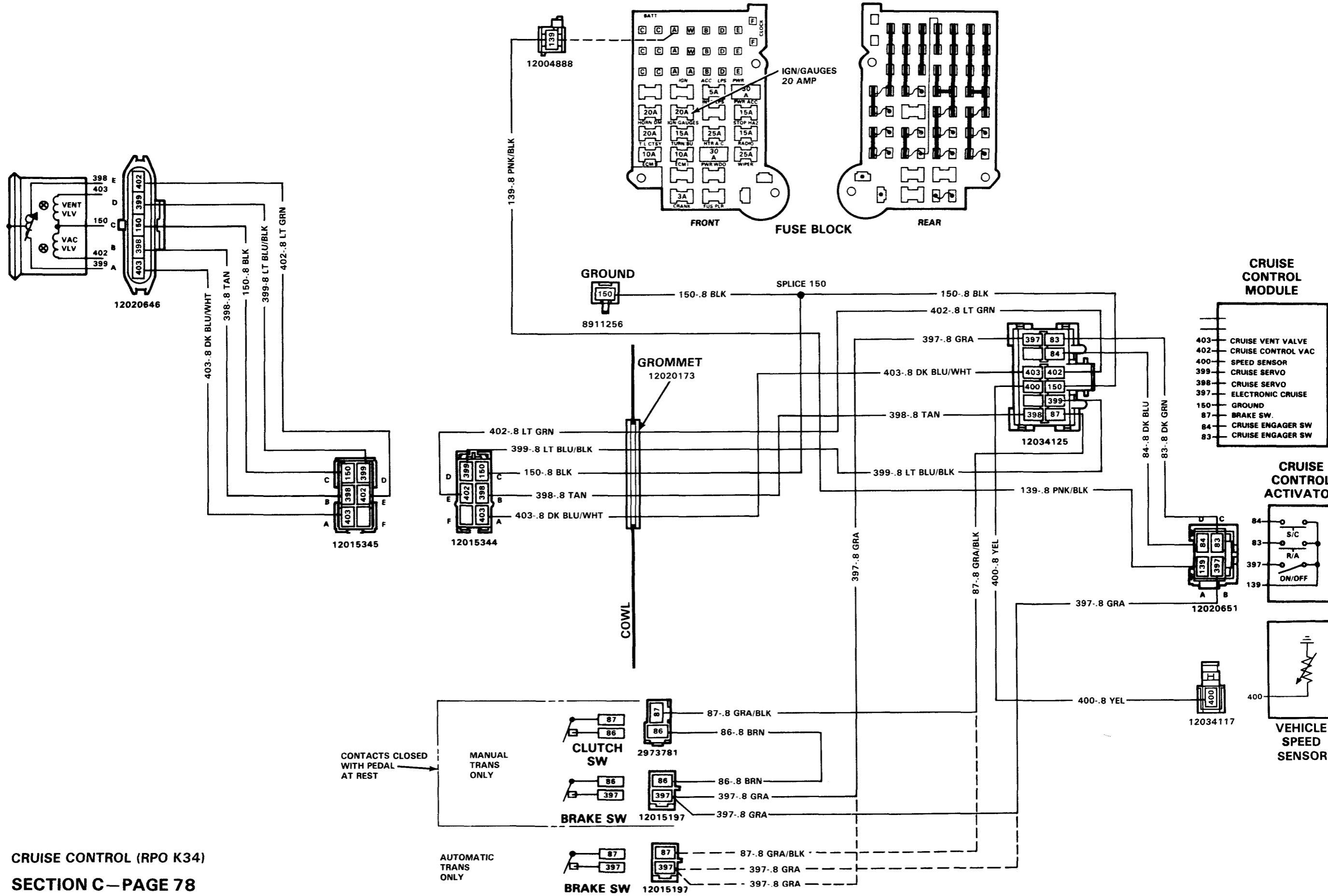

CRUISE CONTROL (RPO K34)
SECTION C—PAGE 78

- CRUISE CONTROL MODULE**
- 403 CRUISE VENT VALVE
 - 402 CRUISE CONTROL VAC
 - 400 SPEED SENSOR
 - 399 CRUISE SERVO
 - 398 CRUISE SERVO
 - 397 ELECTRONIC CRUISE
 - 150 GROUND
 - 87 BRAKE SW.
 - 84 CRUISE ENGAGER SW
 - 83 CRUISE ENGAGER SW

- CRUISE CONTROL ACTIVATOR**
- 84
 - 83 S/C
 - 397 R/A
 - 139 ON/OFF

- VEHICLE SPEED SENSOR**
- 400

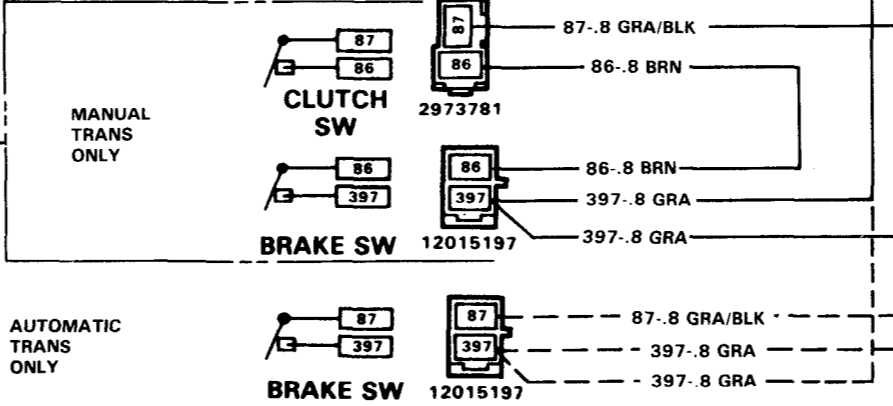
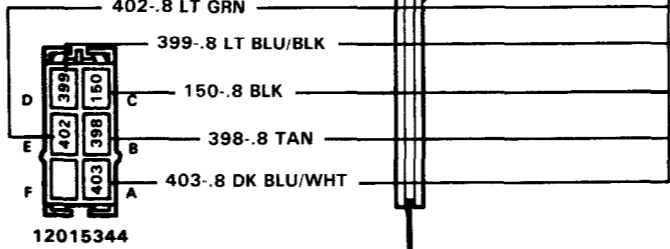
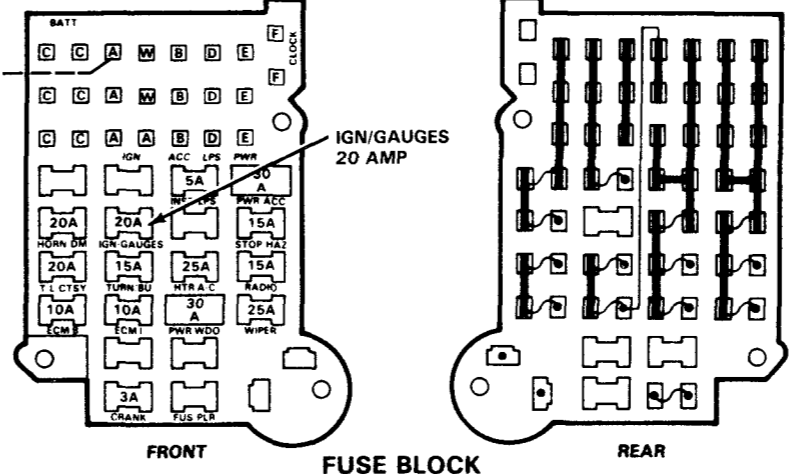

CONTACTS CLOSED WITH PEDAL AT REST

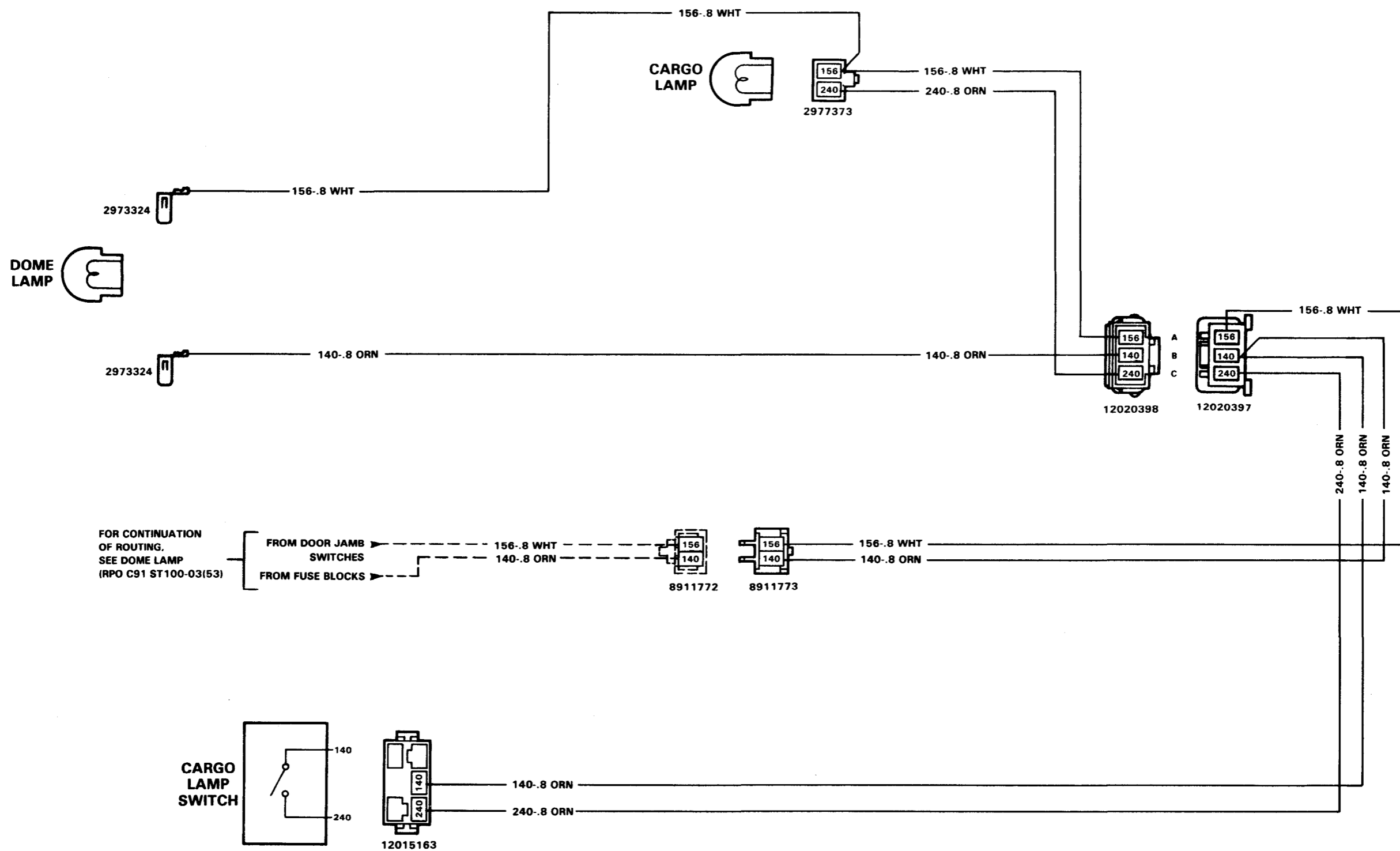

FOR CONTINUATION OF ROUTING, SEE DOME LAMP (RPO C91 ST100-03(53))

FROM DOOR JAMB SWITCHES
FROM FUSE BLOCKS

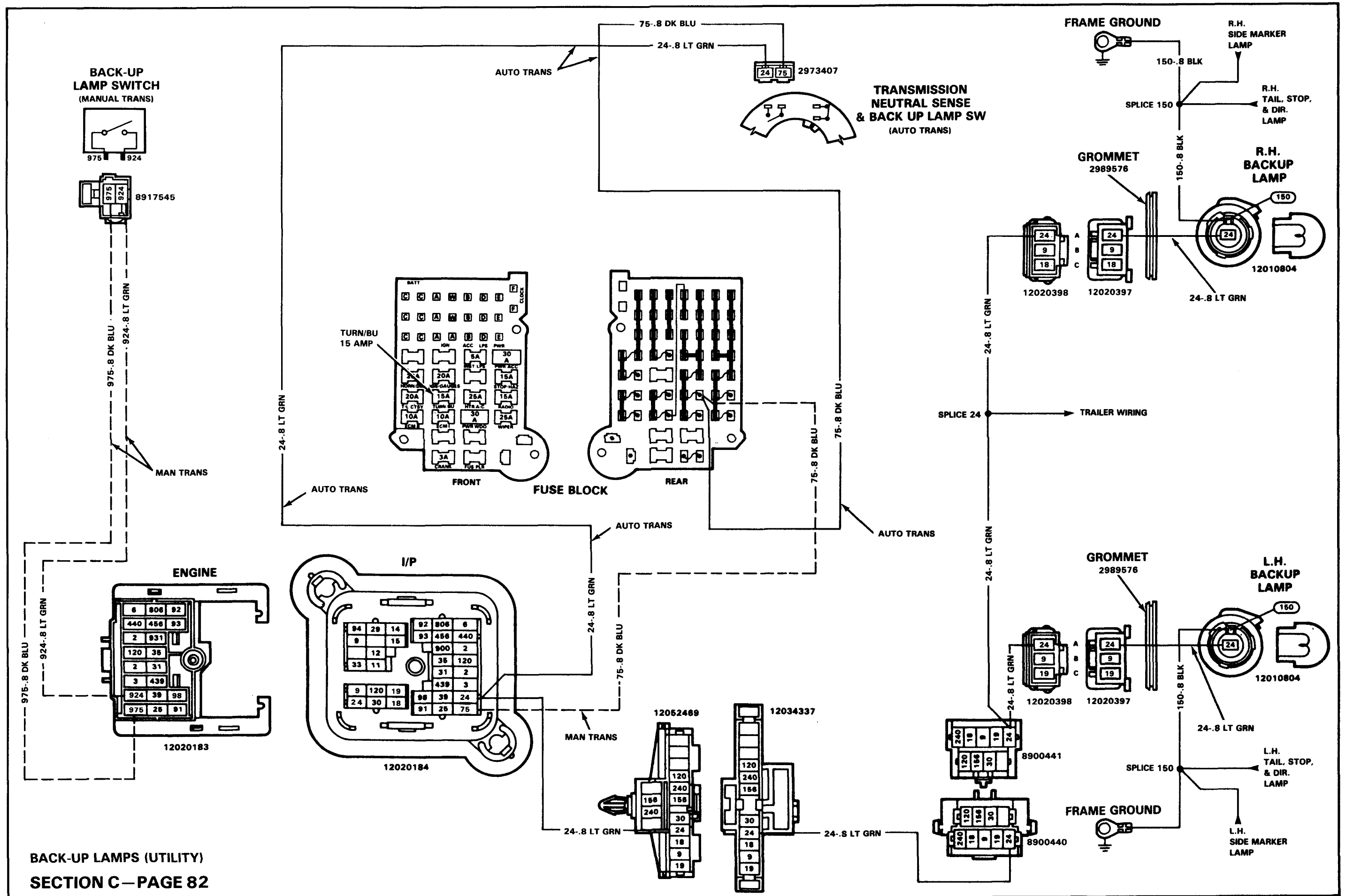

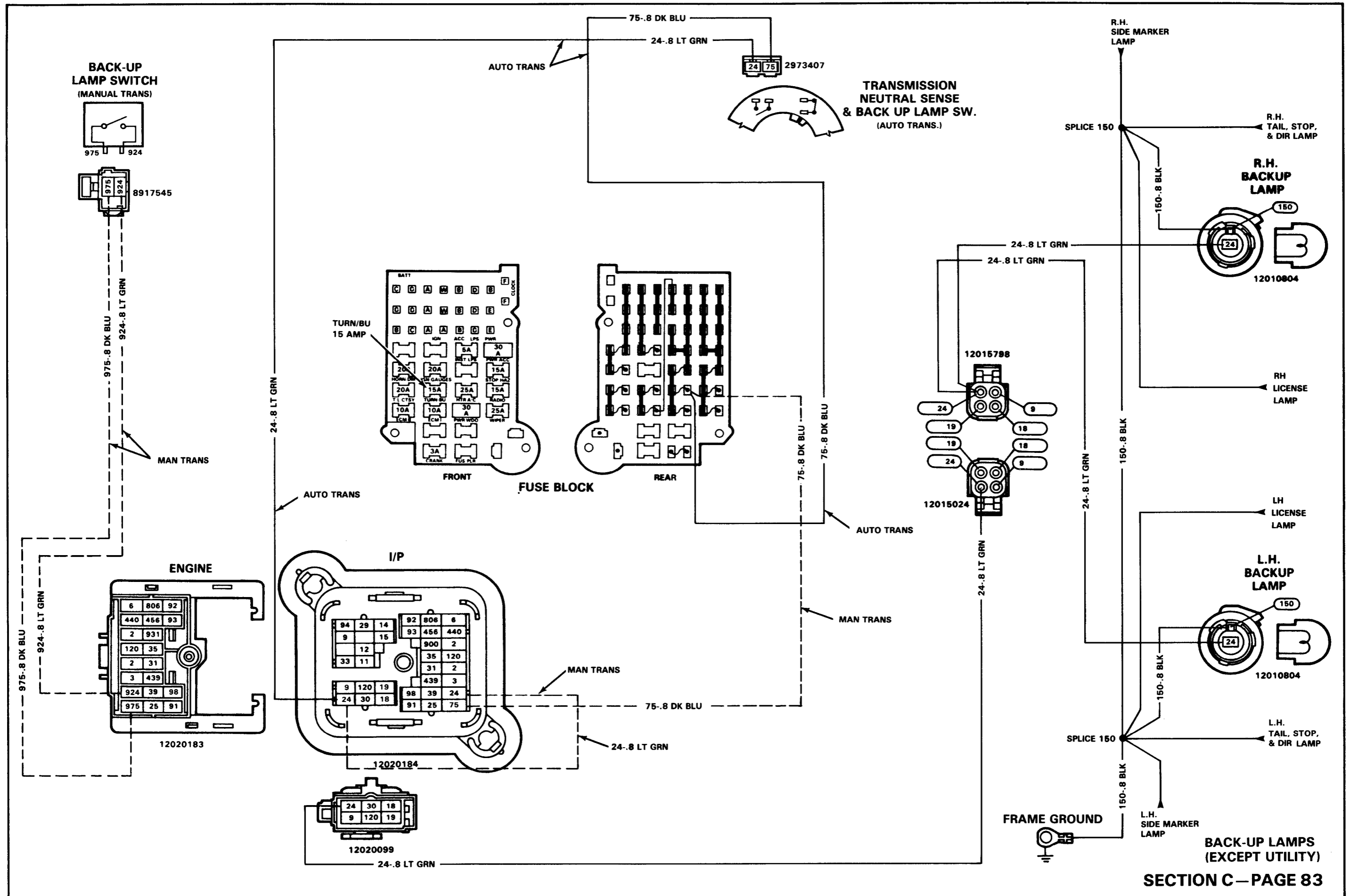

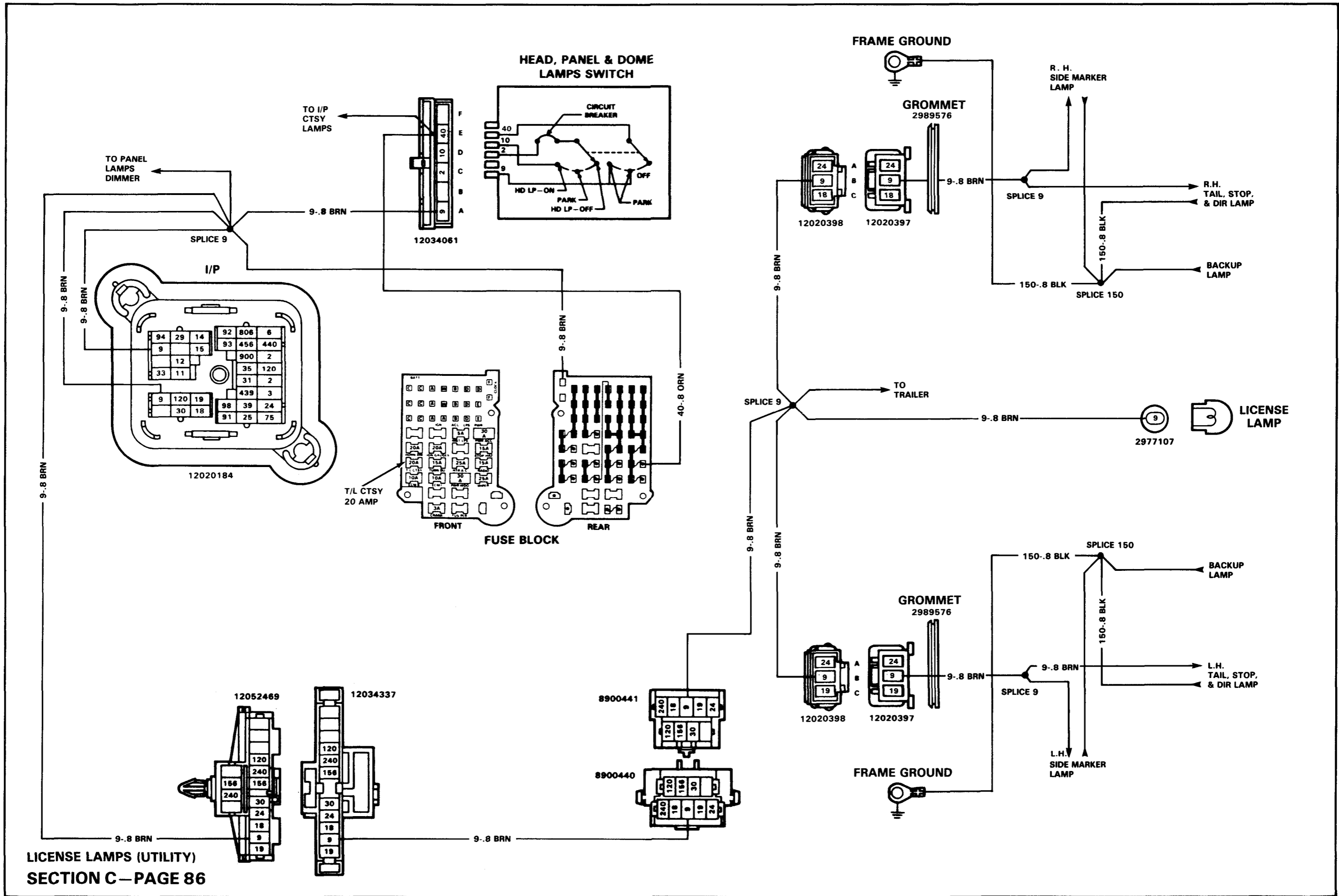

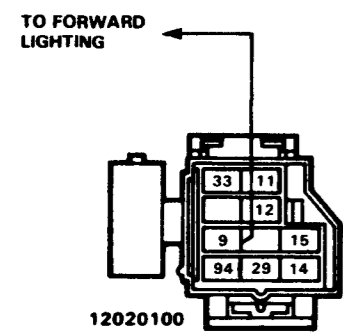

TO PANEL LAMPS DIMMER

SPLICE 9

TO I/P CTSY LAMPS

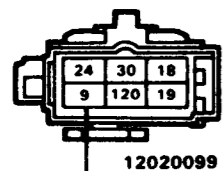
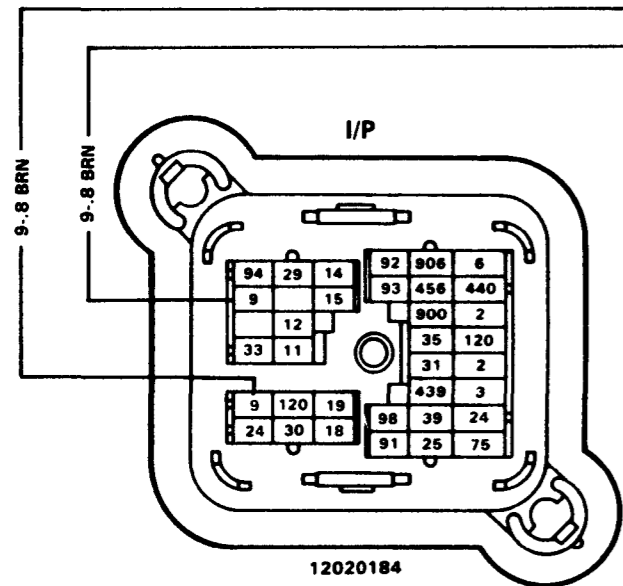
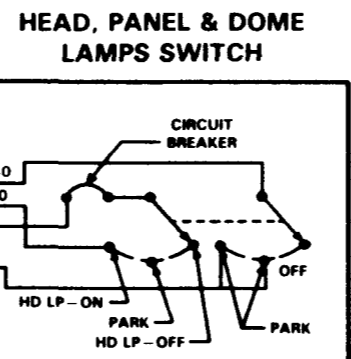
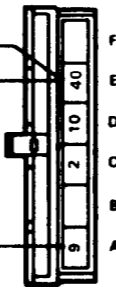

T/L CTSY 20 AMP

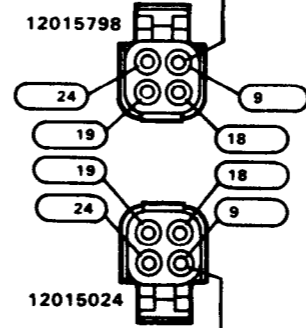
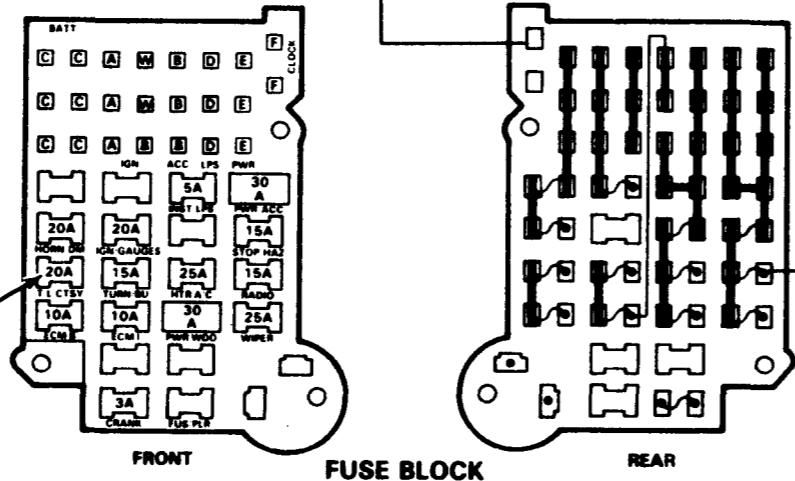

R.H. SIDE MARKER LAMP

R.H. TAIL, STOP, & DIR LAMP

BACKUP LAMP

R.H. LICENSE LAMP

R.H. LICENSE LAMP

BACKUP LAMP

L.H. TAIL, STOP & DIR LAMP

L.H. SIDE MARKER LAMP

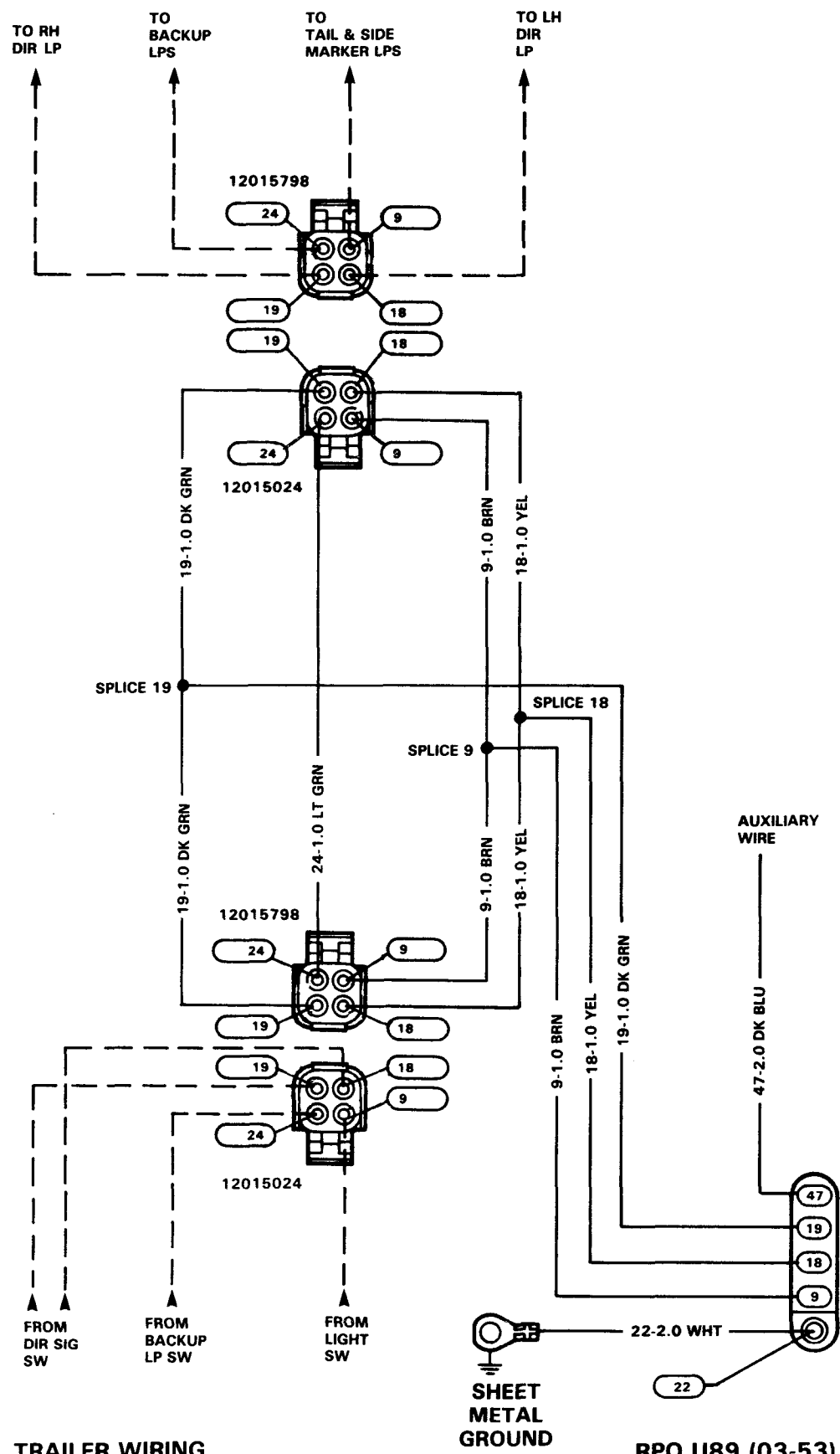

TRAILER WIRING
SECTION C—PAGE 88

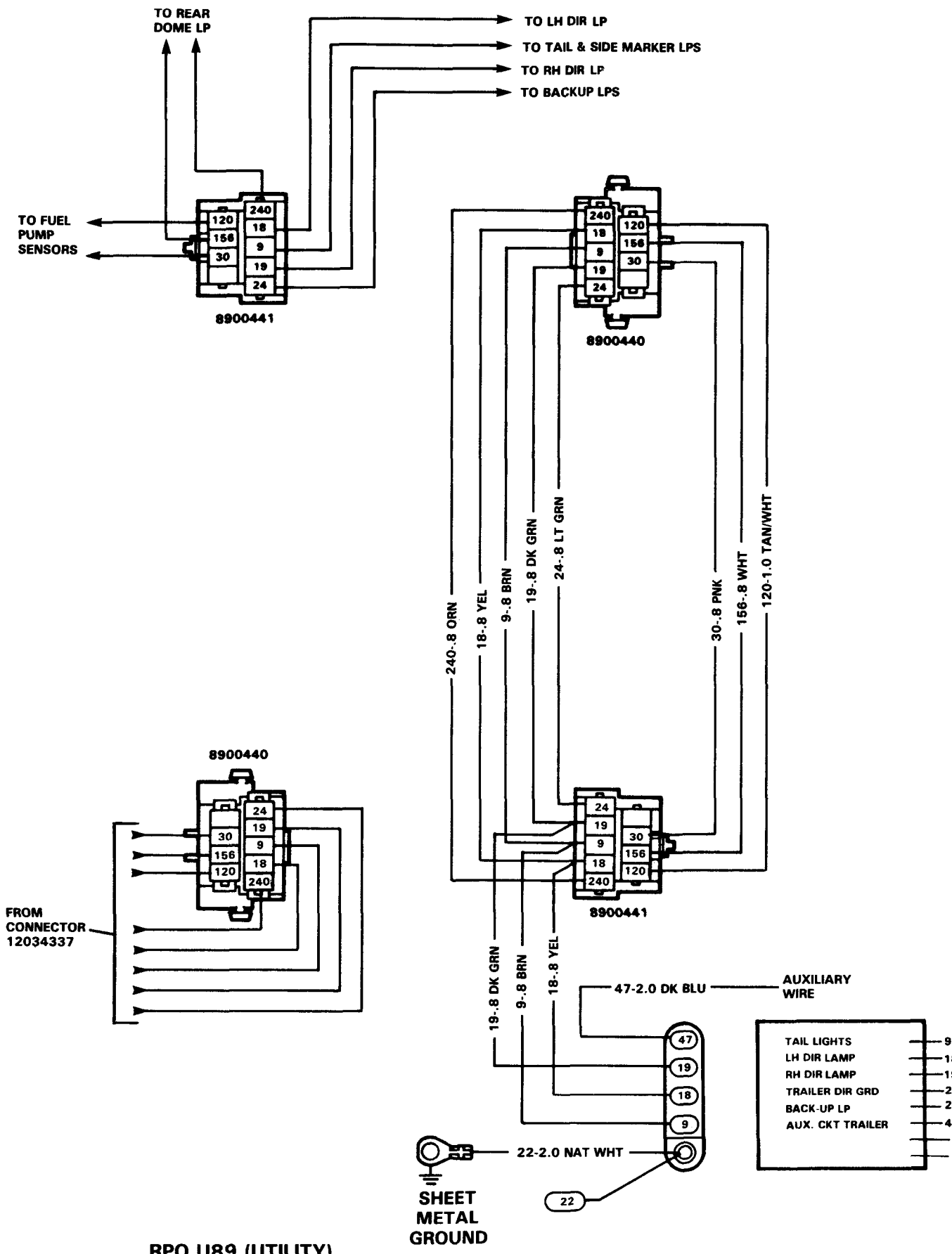

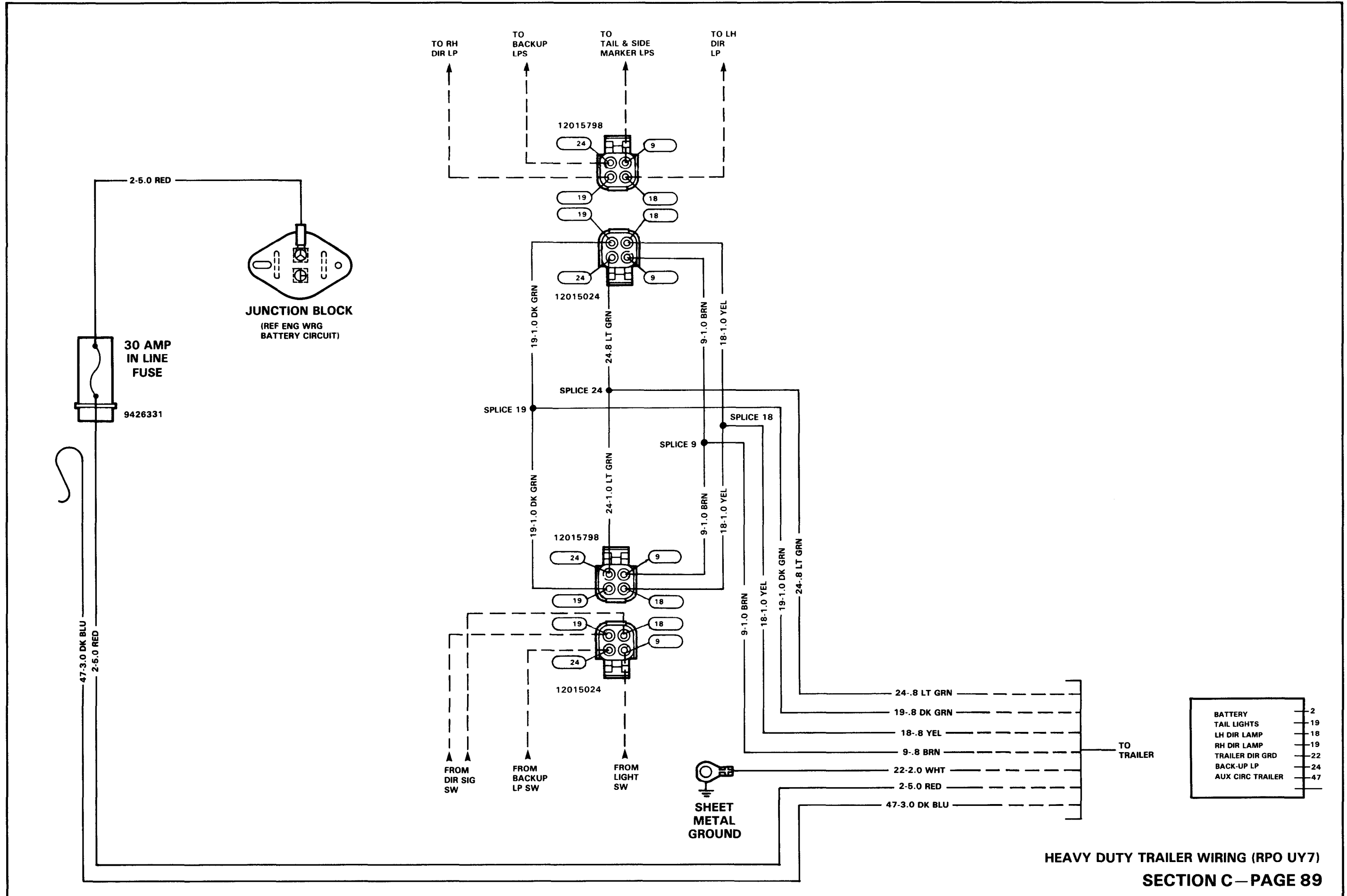

HEAVY DUTY TRAILER WIRING (RPO UY7)
SECTION C—PAGE 89



1988 R/V TRUCK

SECTION D

<u>PAGE</u>	<u>DESCRIPTION</u>	<u>PAGE</u>	<u>DESCRIPTION</u>
2	POWER DISTRIBUTION (GASOLINE)	48	ECM CHART (DIESEL)
4	POWER DISTRIBUTION (DIESEL)	49	ELECTRONIC CONTROL MODULE (ECM)—INPUTS (DIESEL)
5	AUXILIARY BATTERY (TP2)	50	ELECTRONIC CONTROL MODULE (ECM)—OUTPUTS (DIESEL)
7	FUSE BLOCK DETAIL	52	TRANSMISSION CONVERTER CLUTCH DETENT SOLENOID
8	HEAD LAMPS & PARKING LAMPS	53	AUTOMATIC TRANSMISSION KICKDOWN SOLENOID (M40)
10	MARKER LAMPS	54	AIR CONDITIONING (C60)
13	ROOF MARKER LAMPS	55	REAR AIR CONDITIONING (C69)
14	HAZARD LAMPS	56	HEATER
17	DIRECTIONAL LAMPS	57	AUXILIARY HEATER (C36)
20	HORNS	59	INSTRUMENT PANEL LAMPS
21	START (6 CYL.) L25, (8 CYL.) LE8, LT9	60	INSTRUMENT PANEL GAGES
22	START (8 CYL.) LO5, L19	62	INDICATOR LAMPS
23	START (DIESEL) LL4, LH6	64	SEAT BELT WARNING BUZZER
24	IGNITION (6 CYL.) L25	65	BRAKE WARNING SYSTEM
25	IGNITION (8 CYL.) LE8, LT9	66	FOUR-WHEEL DRIVE INDICATOR LAMP
26	IGNITION (8 CYL.) LO5, LT9	68	DOME LAMPS
28	THROTTLE BODY INJECTION	69	CARGO LAMP (UF2)
29	HOT FUEL HANDLING	70	RADIO EQUIPMENT (UM6, UP8)
30	GLOW PLUGS (DIESEL)	71	RADIO EQUIPMENT (U63)
32	ENGINE CONTROLS (DIESEL)	72	POWER WINDOWS (A31)
34	FUEL CONTROL & IDLE AIR CONTROL (8 CYL.) LO5, L19	74	POWER REAR WINDOW (A33)
35	AUXILIARY COOLING FAN	75	REAR DEFOGGER (C49)
36	AUXILIARY FUEL TANK (NL2)/FUEL TANK SELECTOR SWITCH	76	POWER DOOR LOCKS
38	EMISSION CONTROLS	78	WIPER/WASHER
43	ELECTRONIC CONTROL MODULE (ECM)—INPUTS (8 CYL.) LO5, L19	79	PULSE WIPER/WASHER (CD4)
44	ELECTRONIC CONTROL MODULE (ECM)—OUTPUTS (8 CYL.) LO5, L19	81	BACKUP LAMPS
47	ECM CHART (8 CYL.)	84	TAIL LAMPS
		88	LICENSE LAMPS
		92	CAMPER & TRAILER WIRING

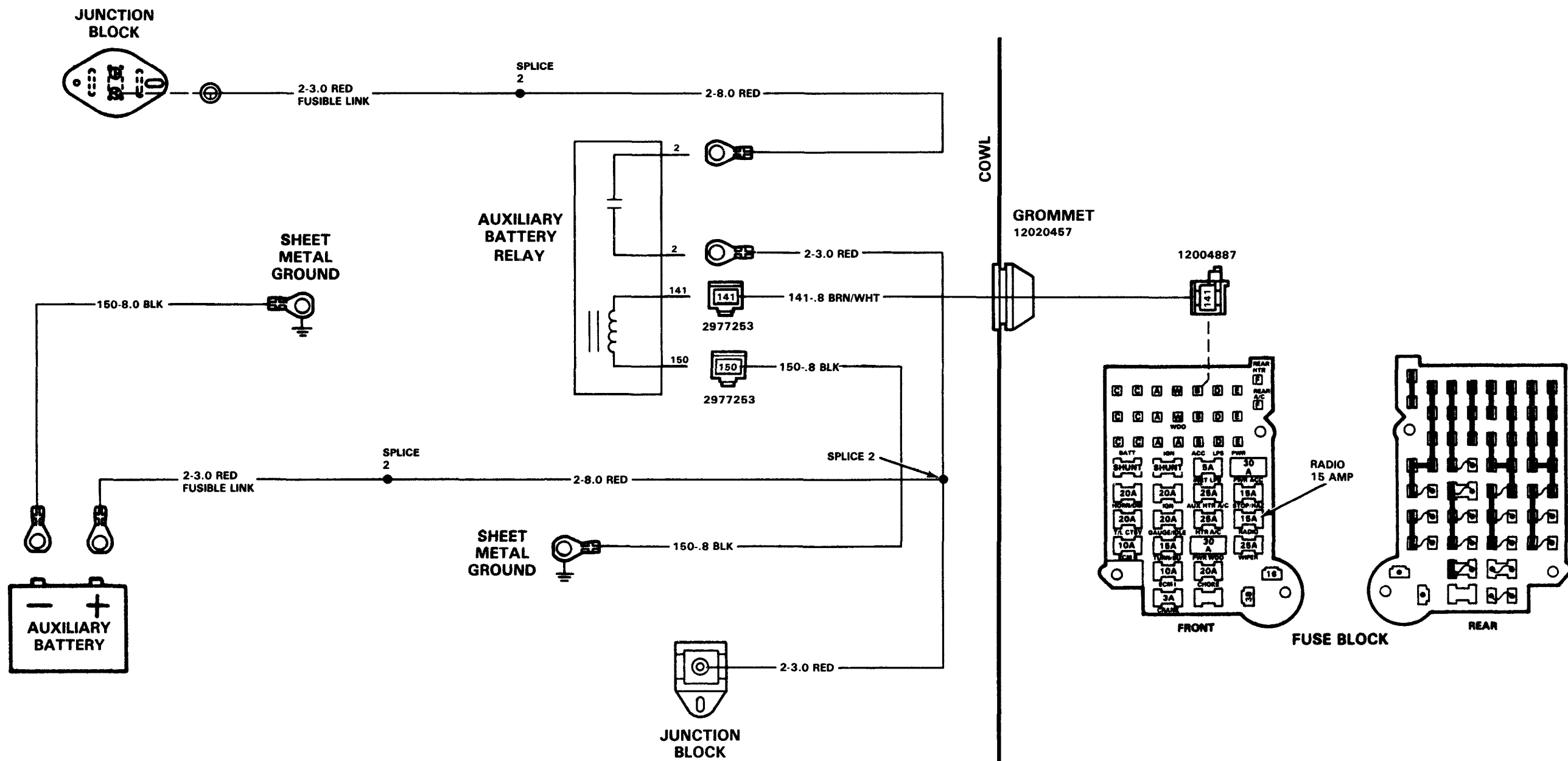

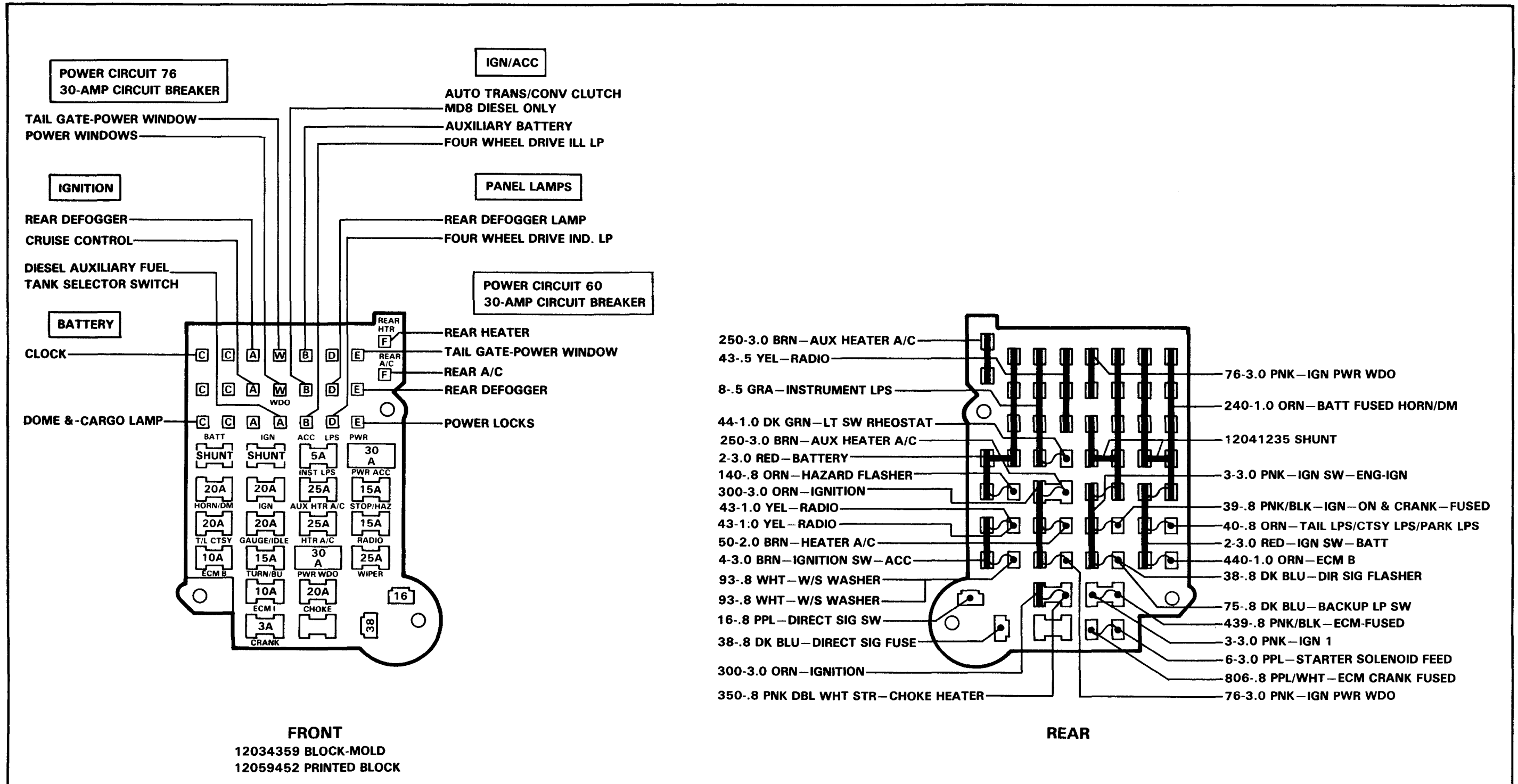

FRONT
 12034359 BLOCK-MOLD
 12059452 PRINTED BLOCK

	COLOR	MALE CONN
A	NAT	12004888
B	BRN	12004887
C	BLK	12004886
D	GRN	12004885
E	RED	12004883
W	BLU	12004884
F	DK GRA	12004740

FUSES	AMP	COLOR
12004005	5	TAN
12004007	10	RED
12004008	15	LT BLU
12004009	20	YEL
12004010	25	WHT
12004003	3	VIOLET
12004006	7.5	BROWN
12004011	30	LT GRN

NOTE LL4/LT9/LE8/L25 ENGINES DO NOT USE THE CRANK ECM I OR ECM B FUSES

LH6 ENGINES DO NOT USE THE CRANK FUSE

LO5/L19/LH6/LL4 ENGINES DO NOT USE THE CHOKE FUSE

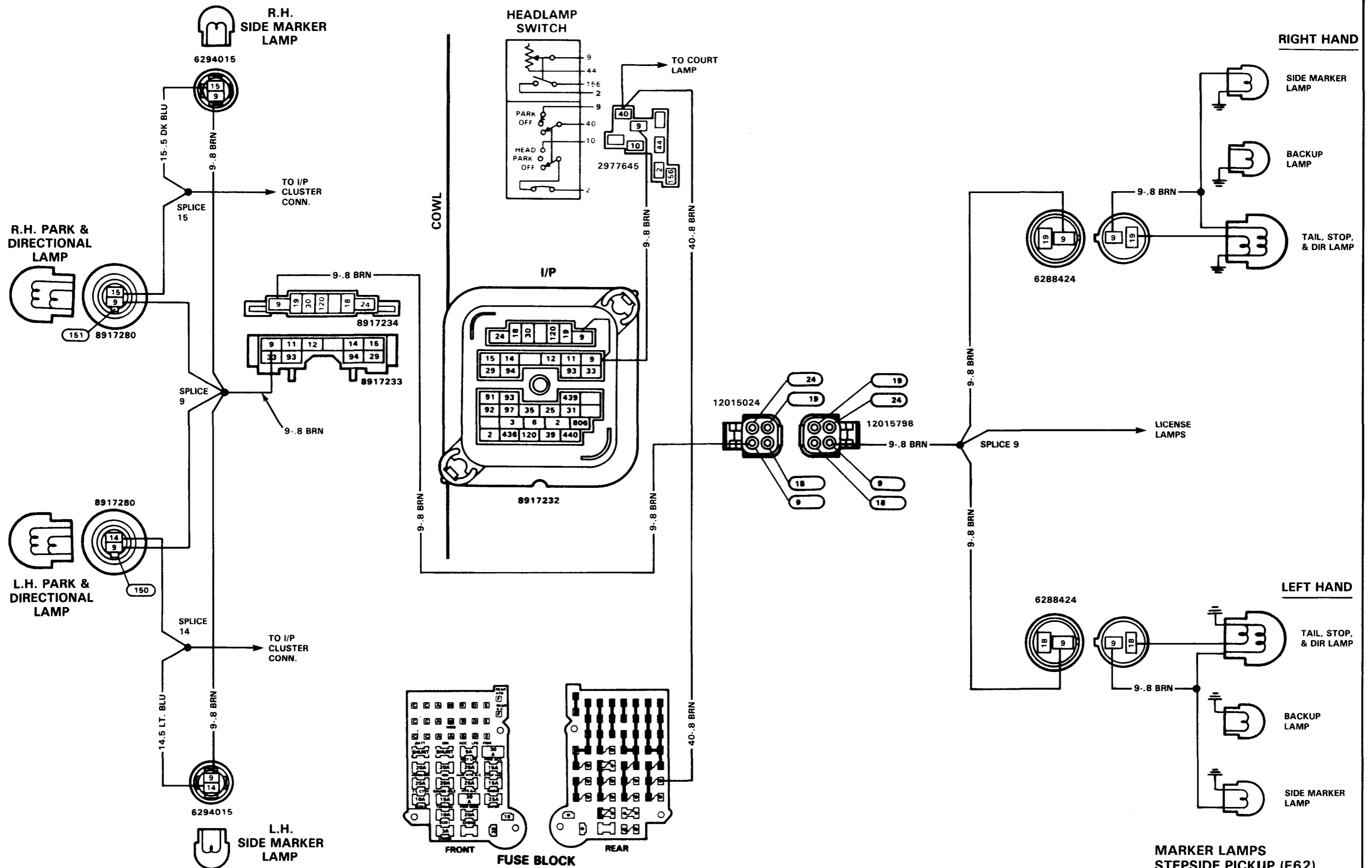

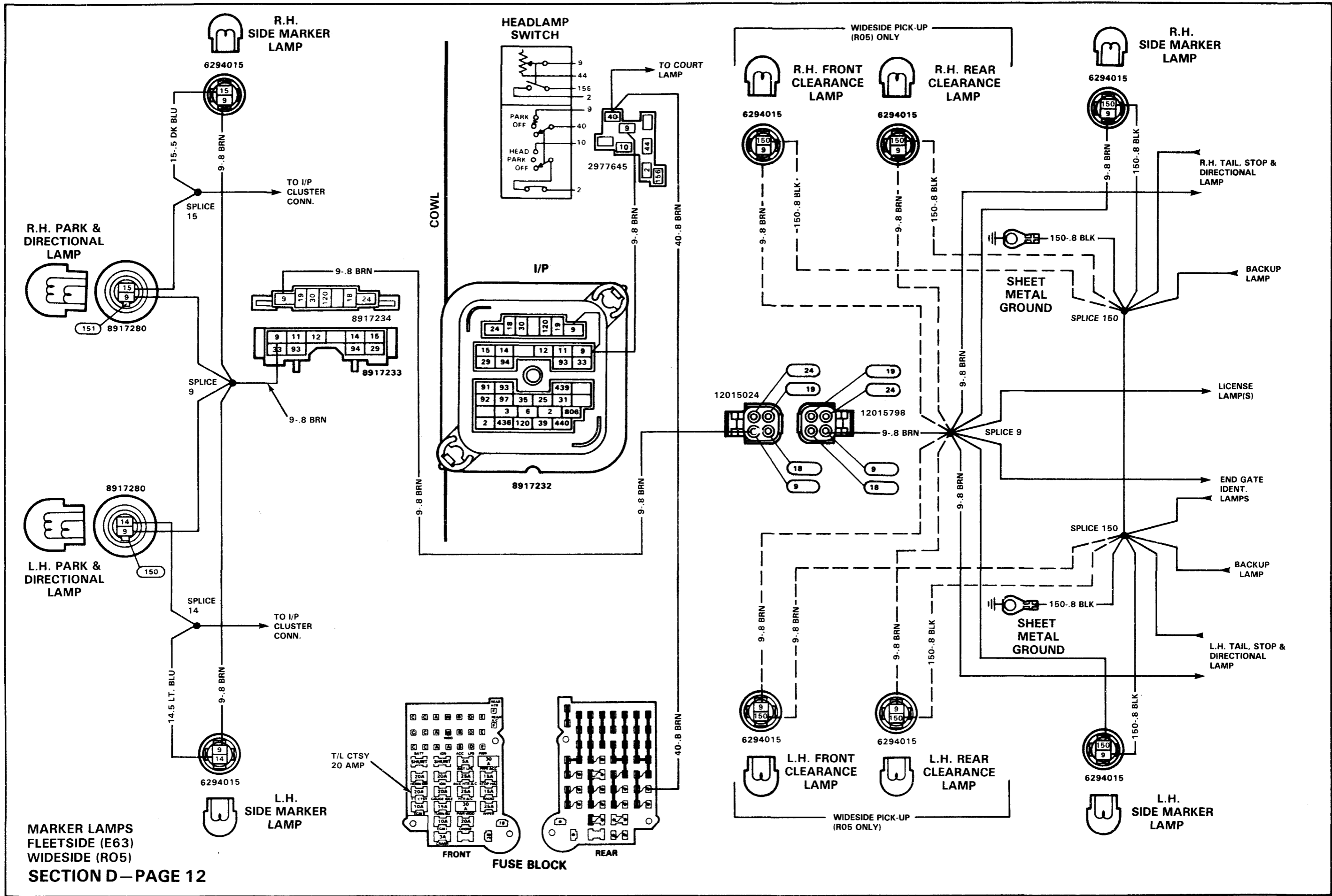

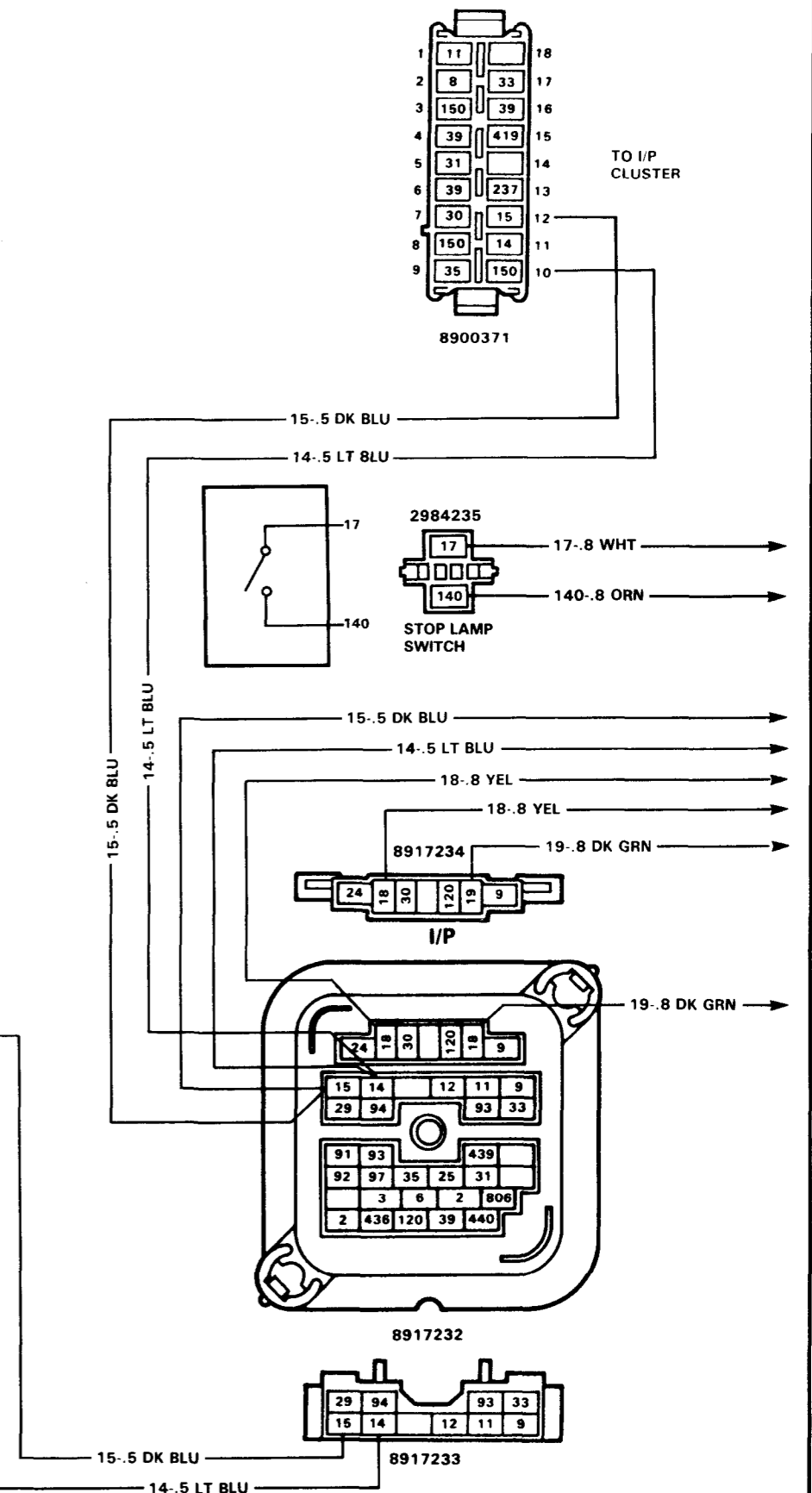
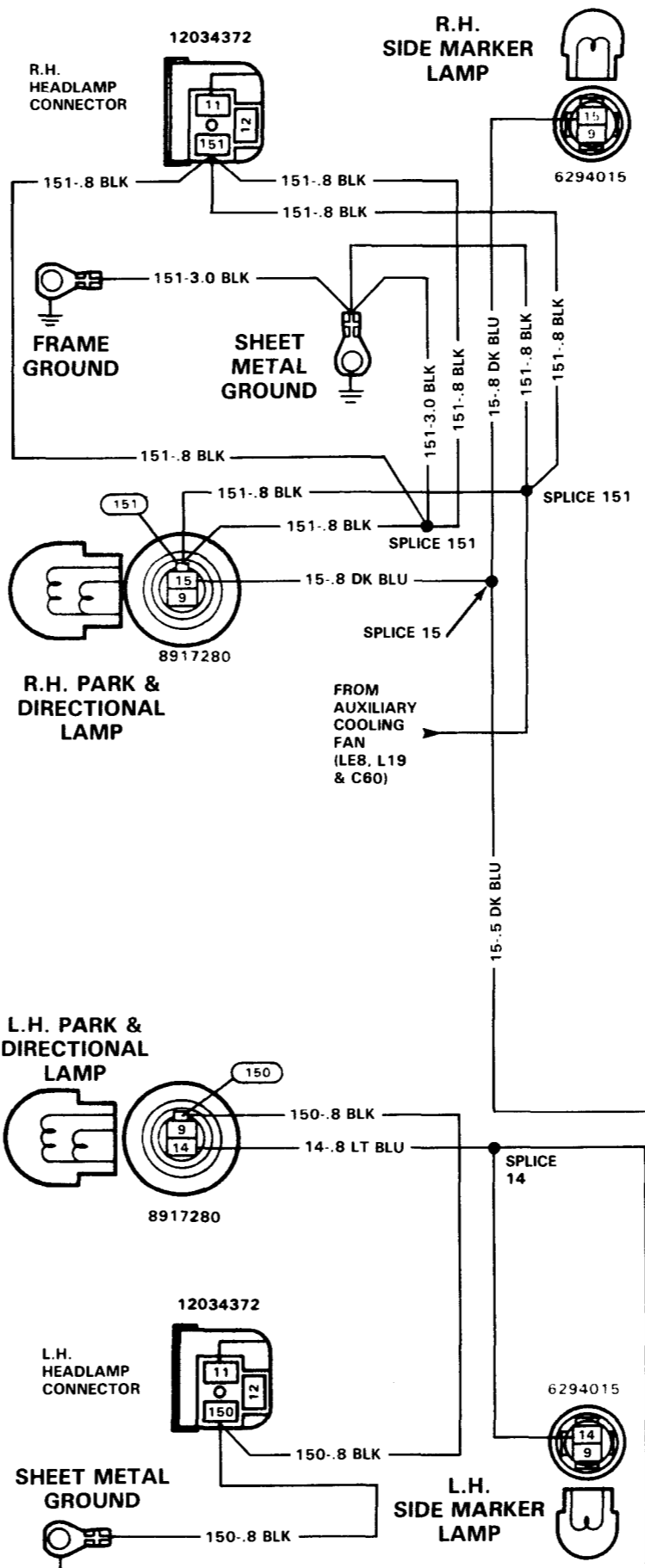
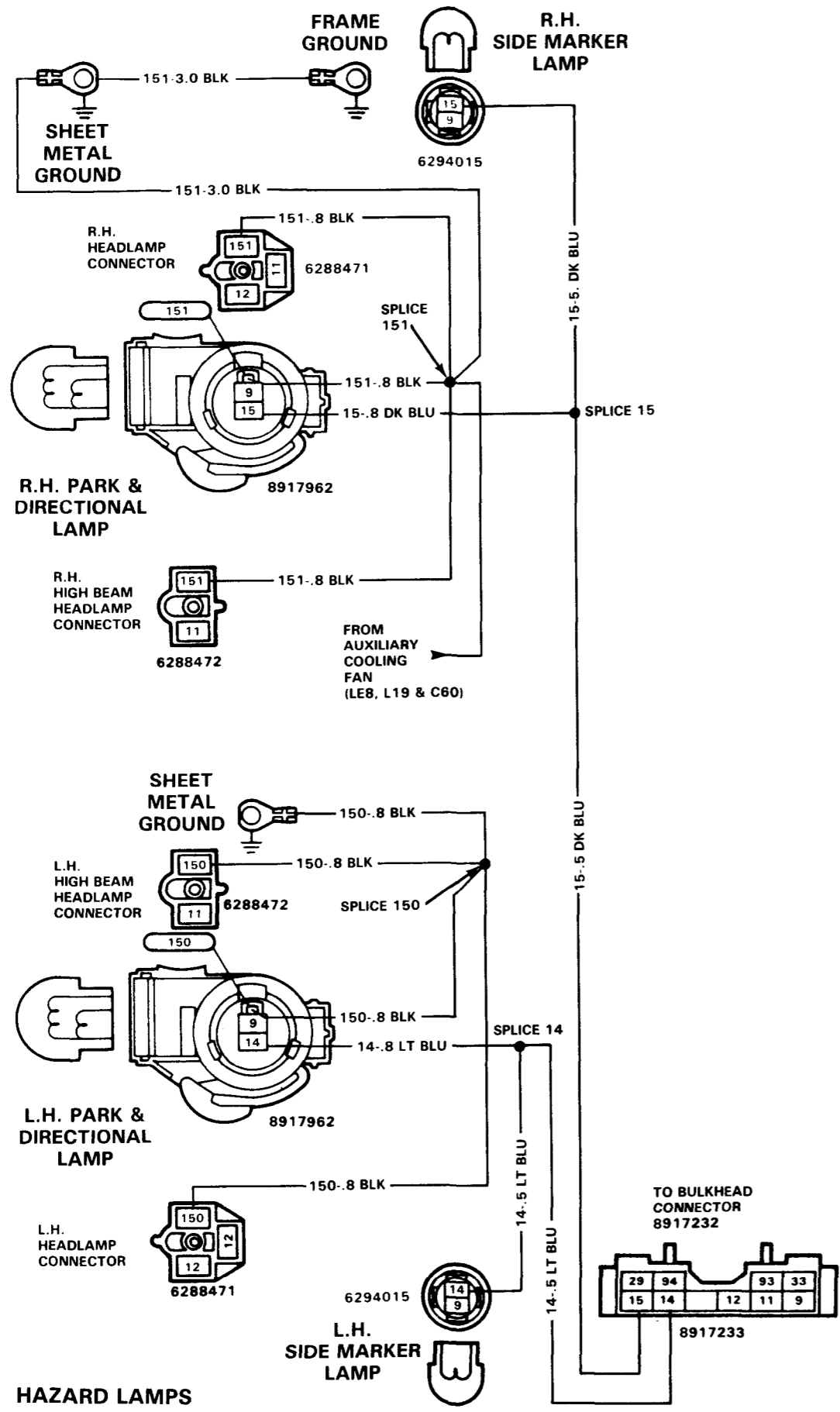

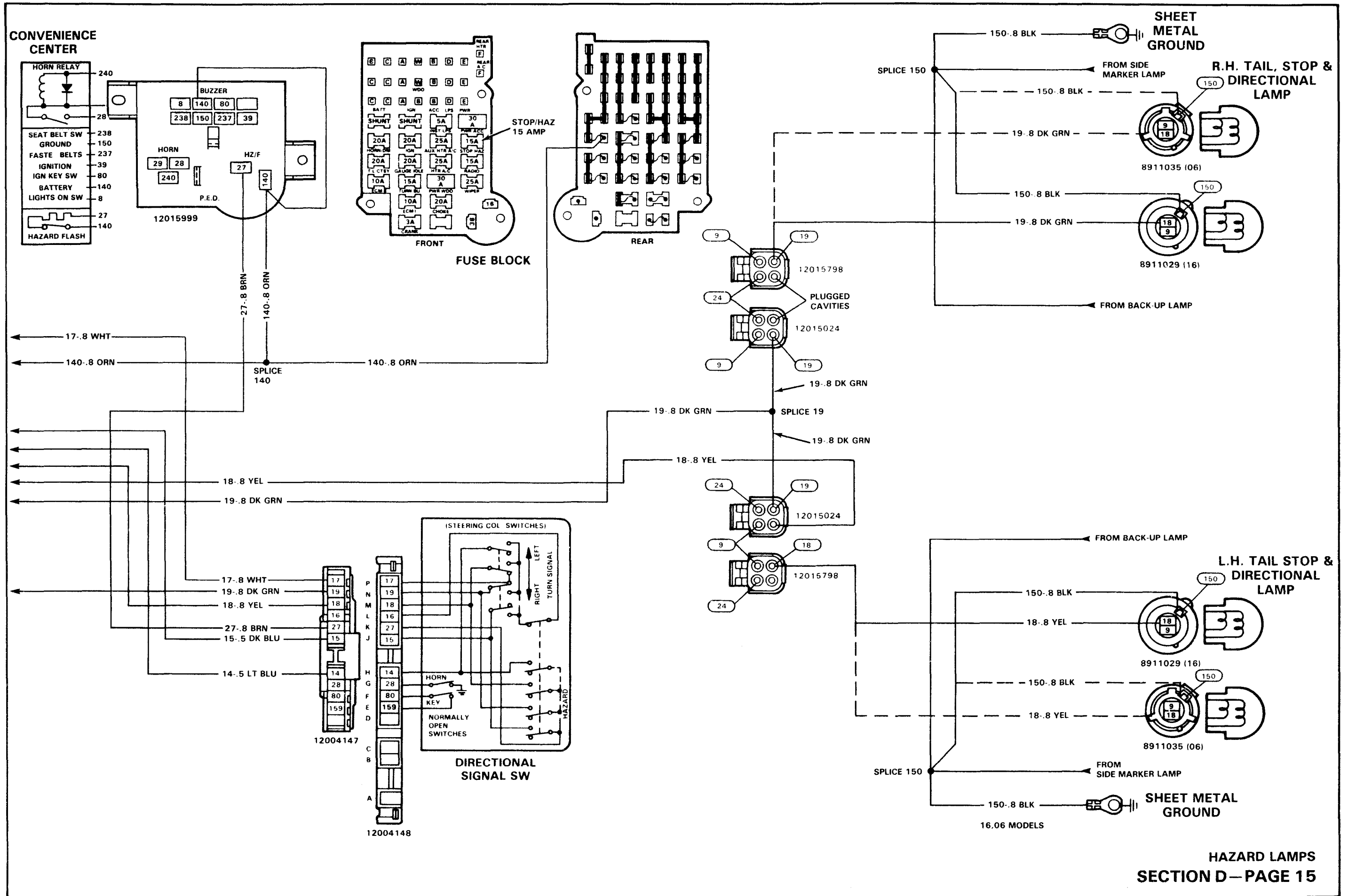

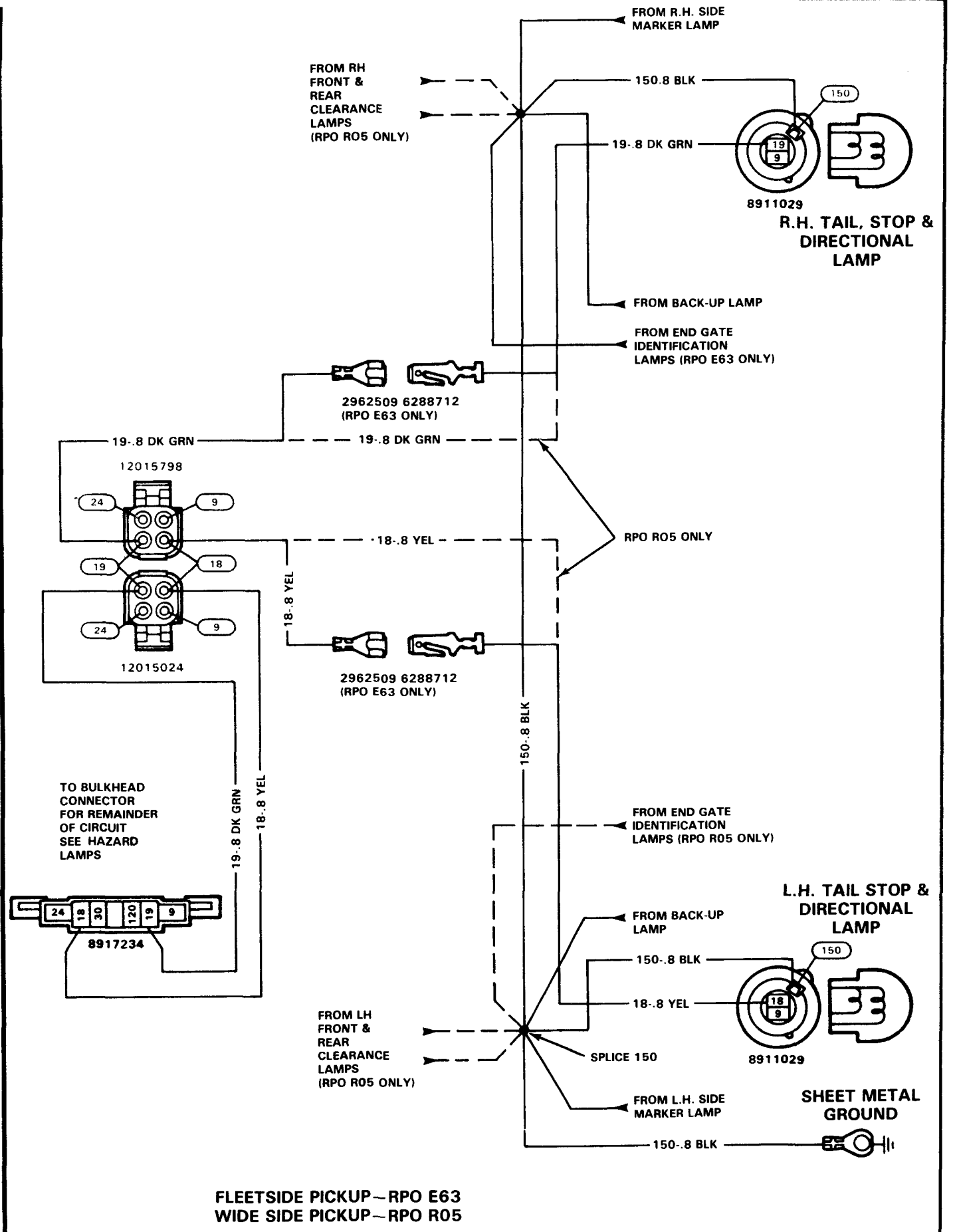
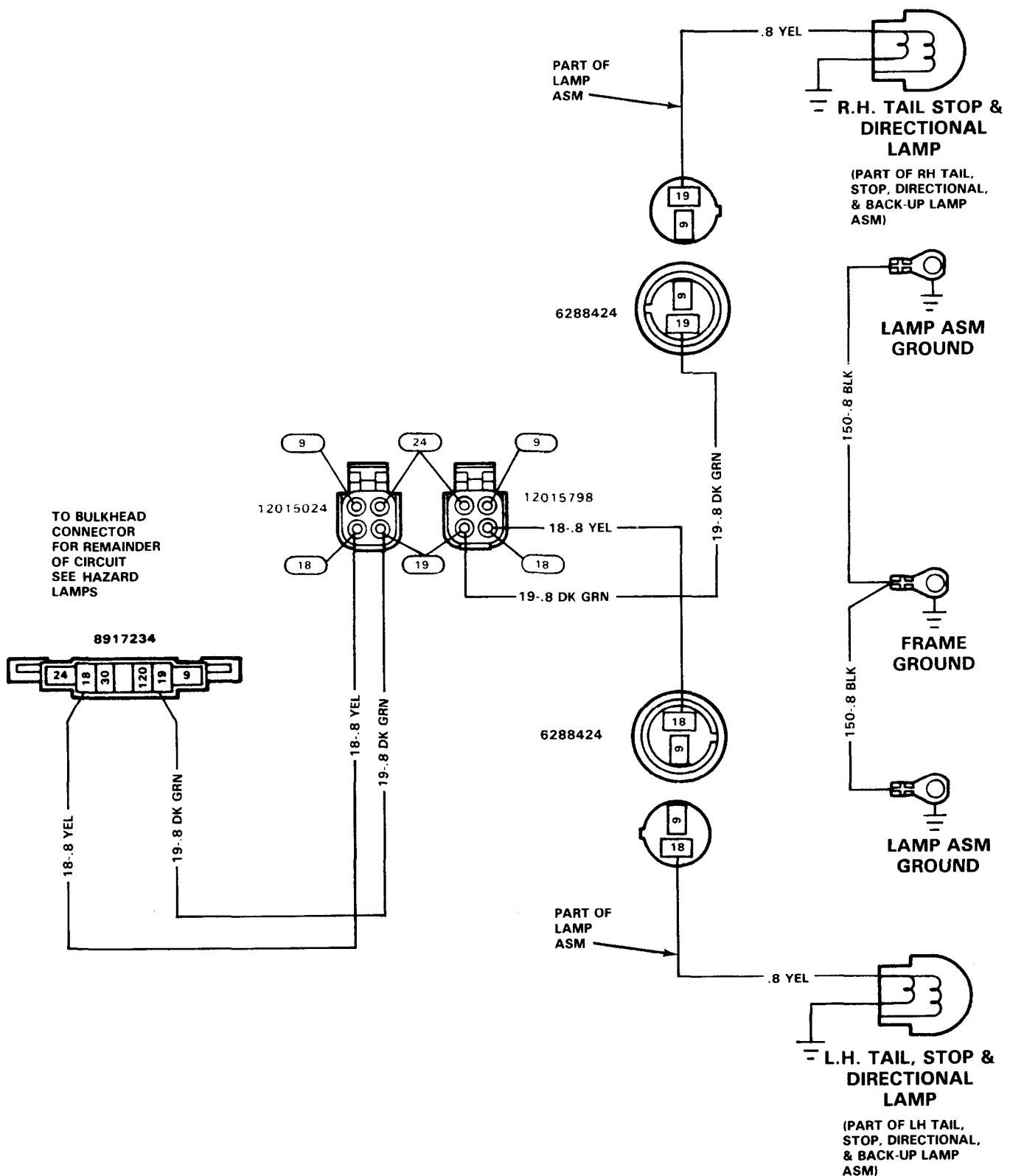

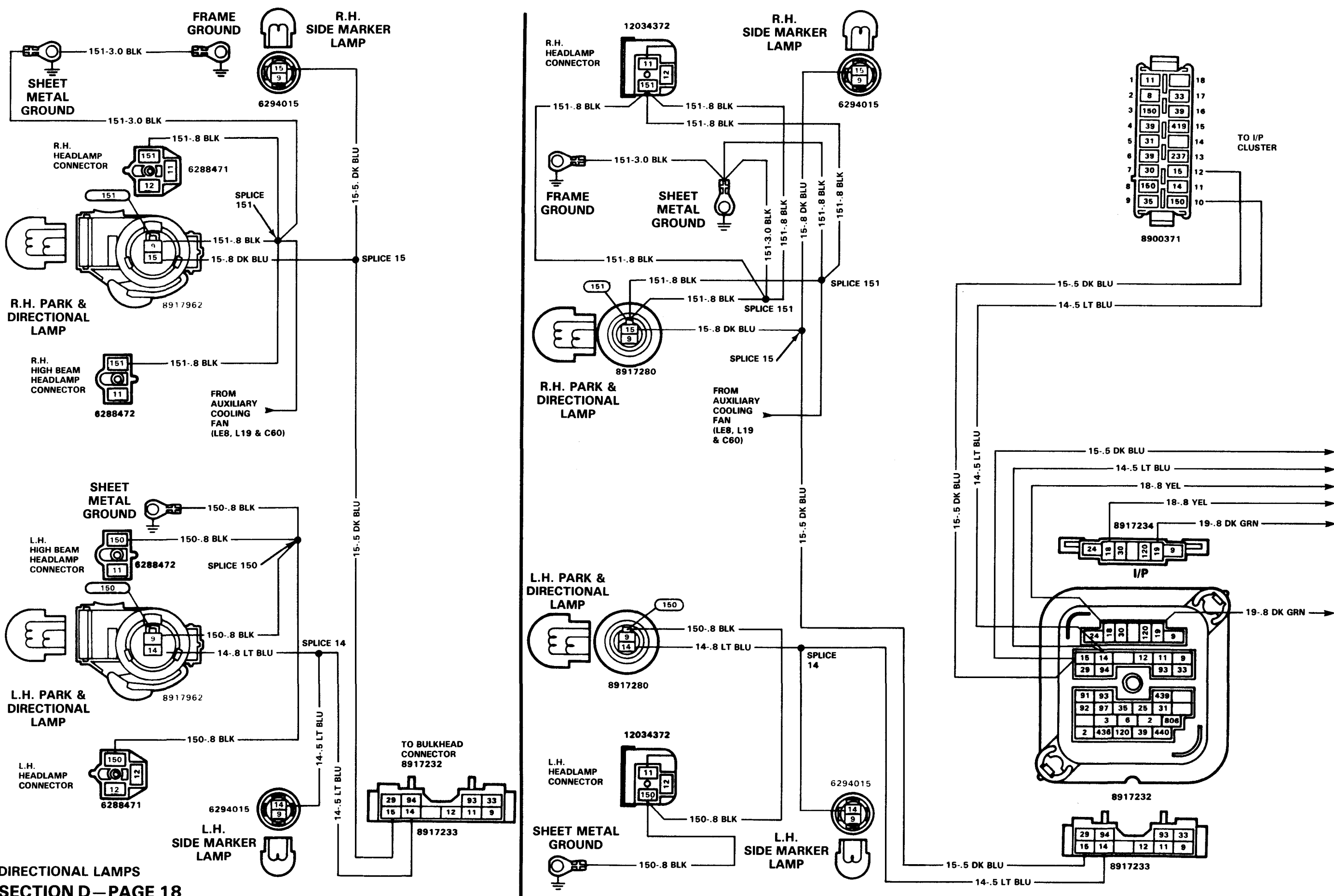

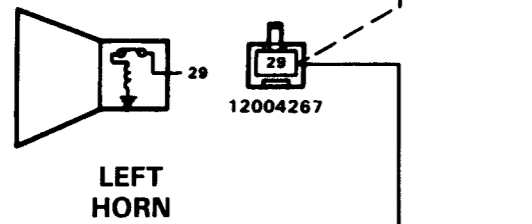
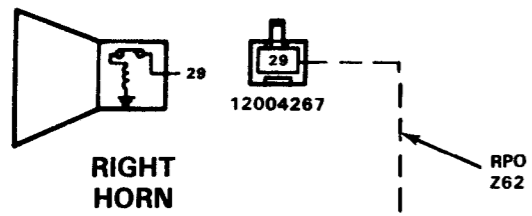

RPO Z62

29-1.0 BLK/GRN

29-1.0 DK ORN

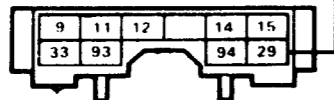

8917233

COWL

CONVENIENCE CENTER

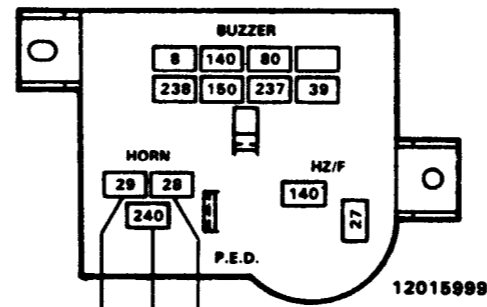
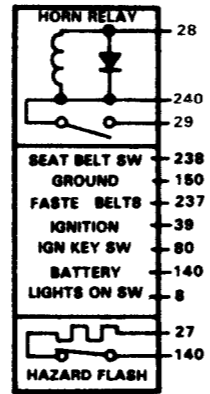

12015999

28-5 BLK

240-1.0 ORN

240-1.0 ORN

29-1.0 BLK/GRN

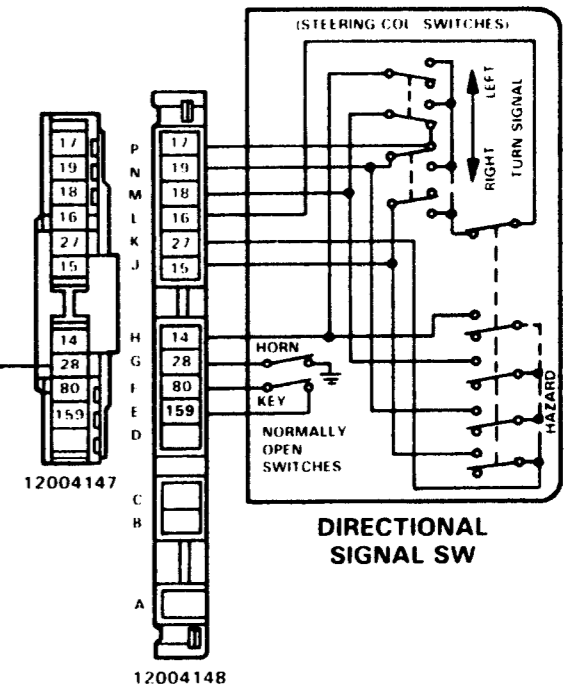

DIRECTIONAL SIGNAL SW

12004148

I/P

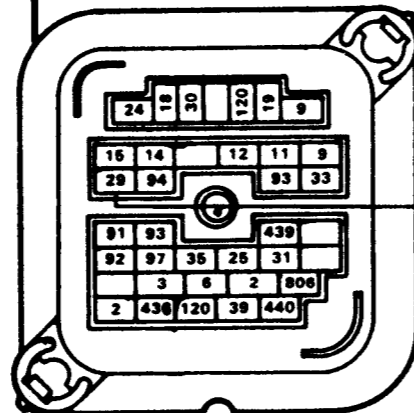

8917232

HORN/DM
20 AMP

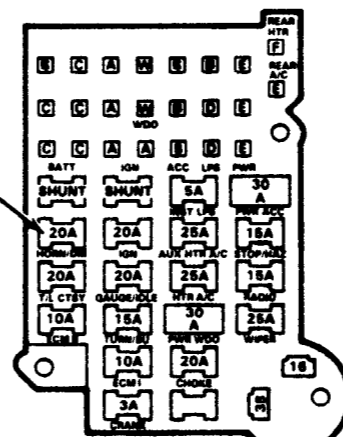

FRONT

FUSE BLOCK

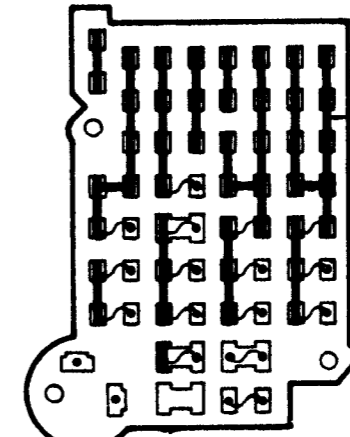

REAR

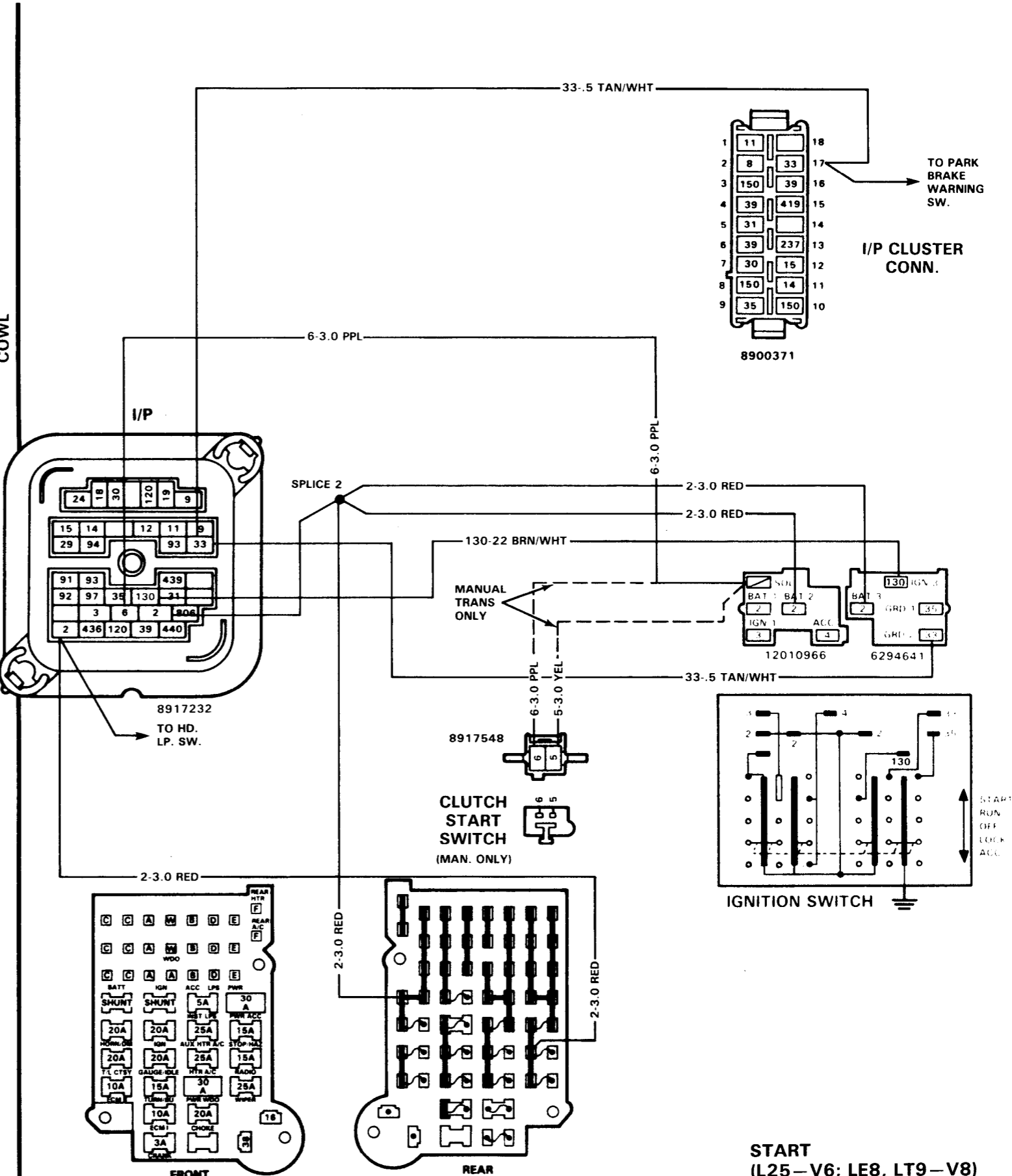
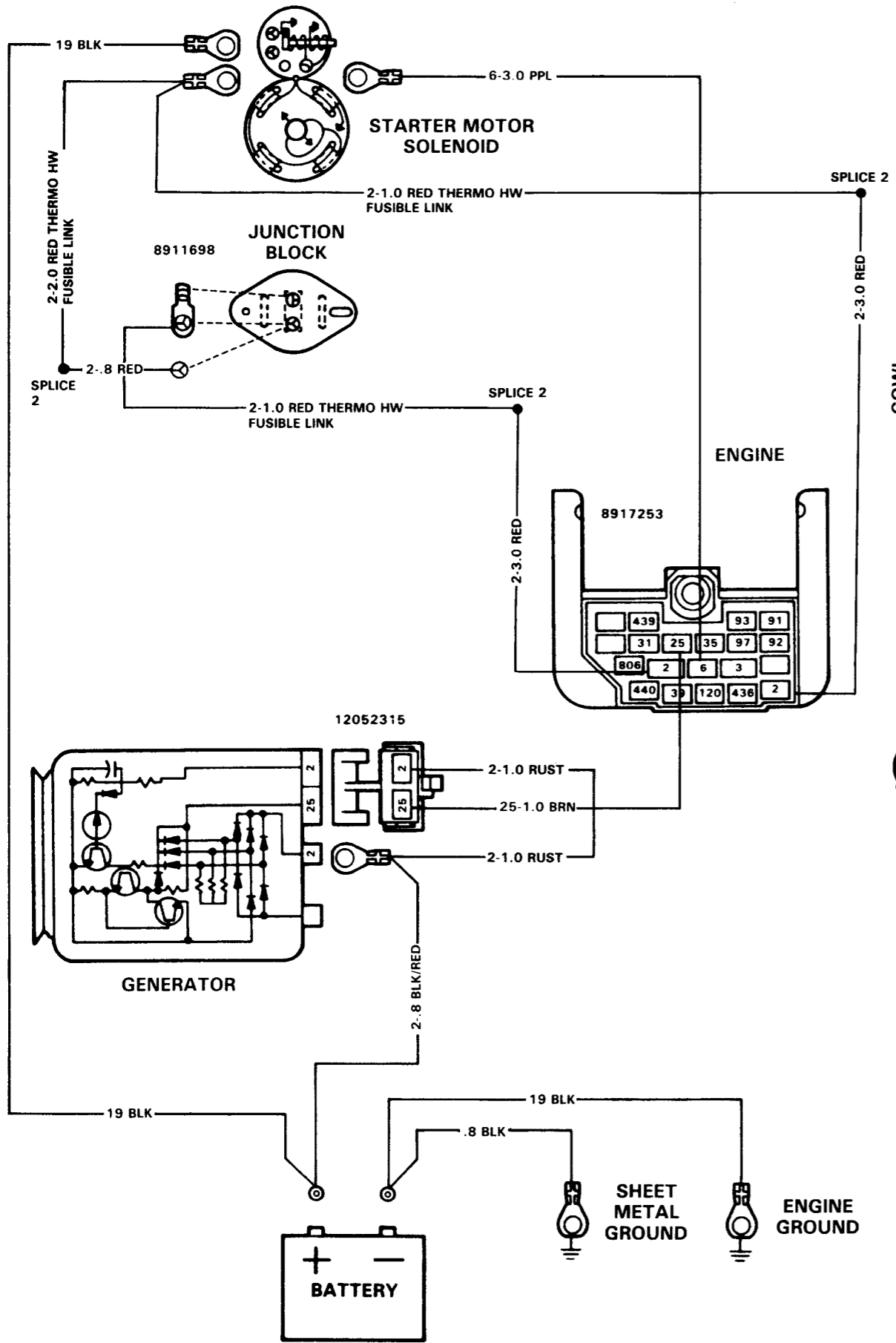

START
(L25-V6; LE8, LT9-V8)
SECTION D-PAGE 21

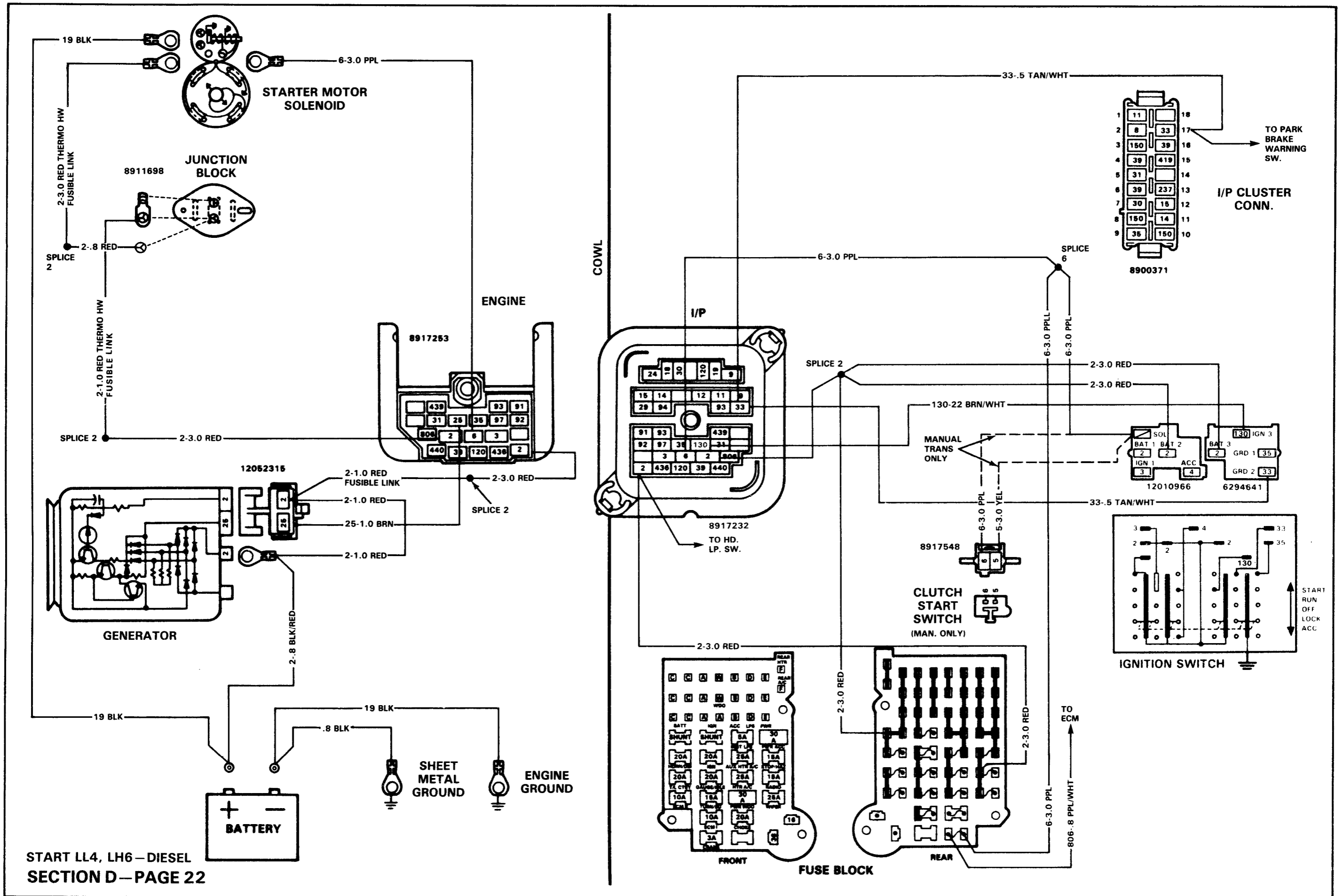

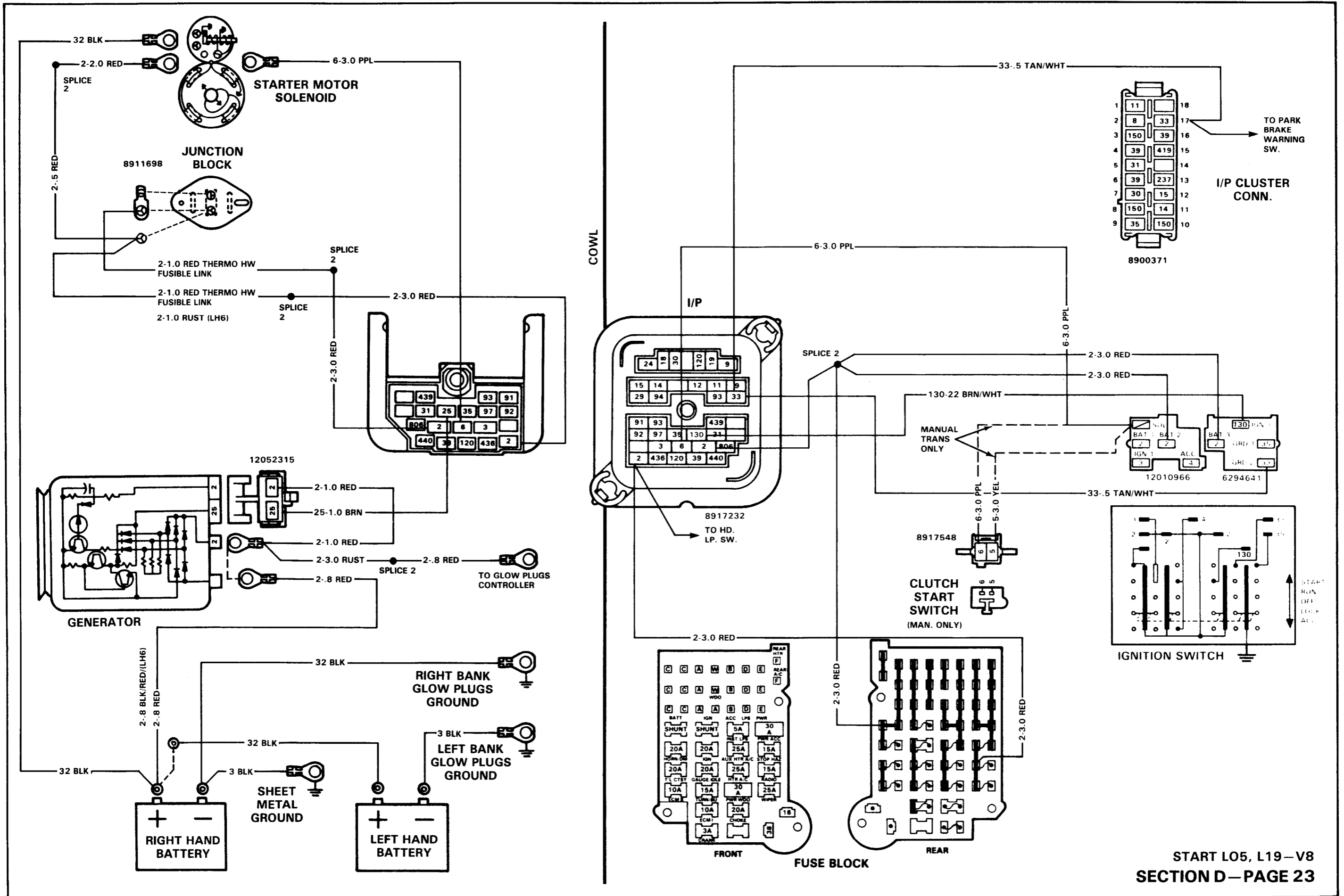

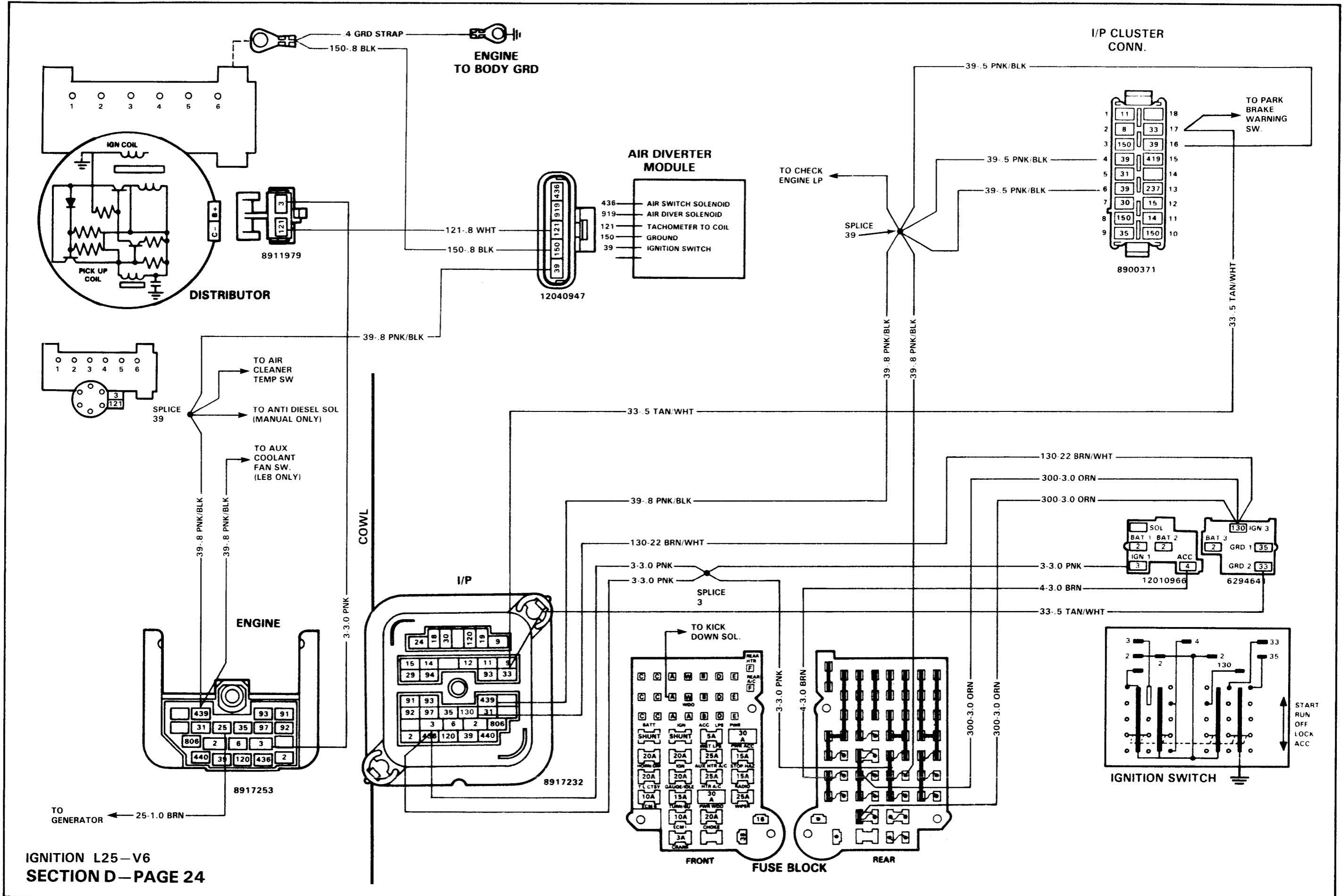

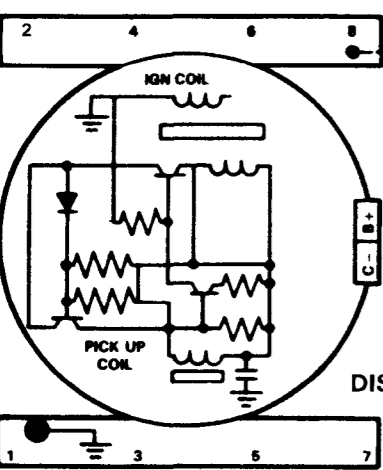
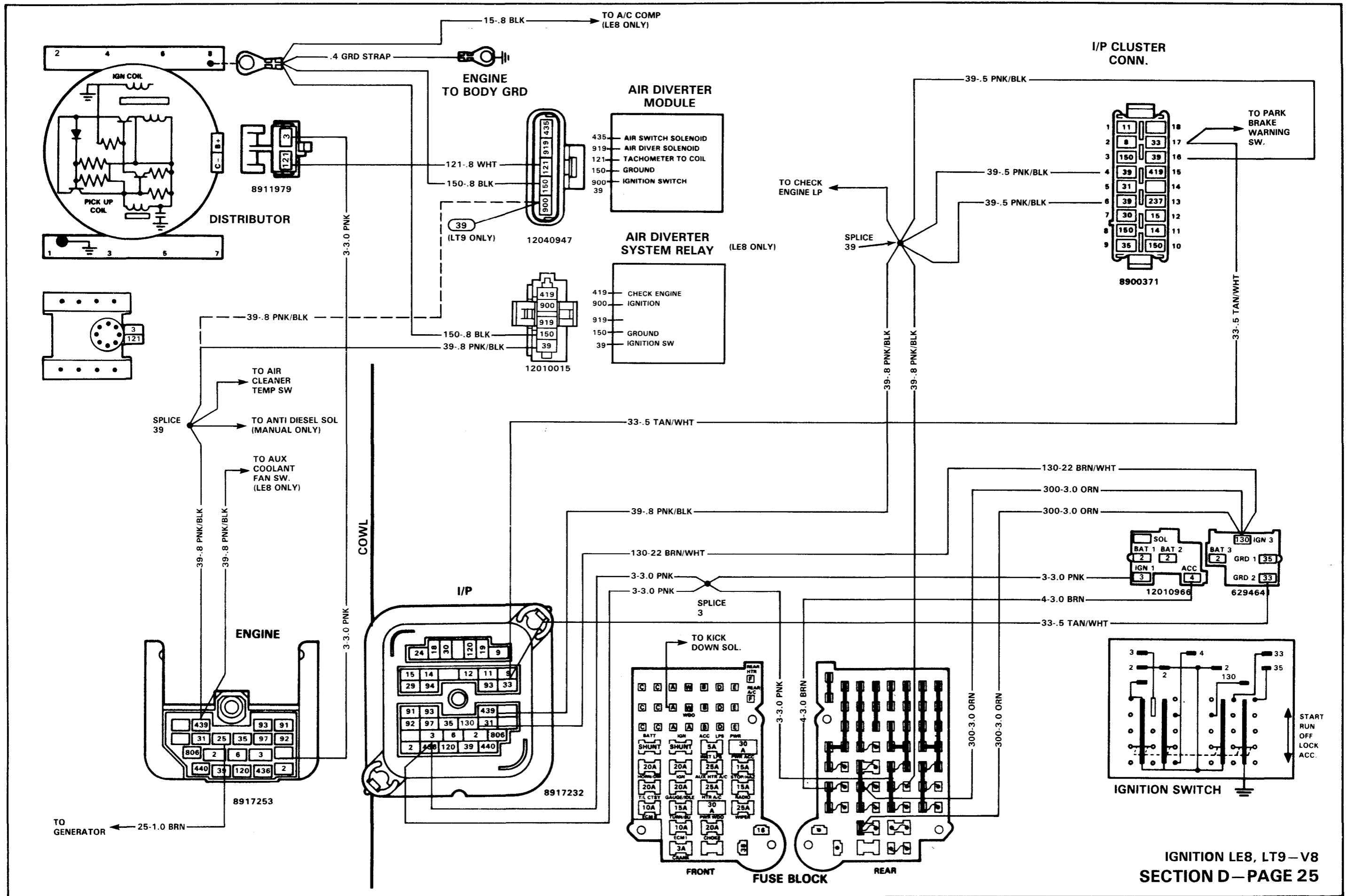

8911979

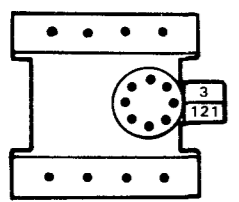

TO AIR CLEANER TEMP SW
TO ANTI DIESEL SOL (MANUAL ONLY)
TO AUX COOLANT FAN SW. (LE8 ONLY)

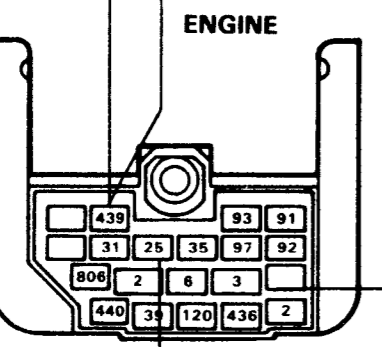

8917253

TO GENERATOR ← 25-1.0 BRN

15-8 BLK → TO A/C COMP (LE8 ONLY)

4 GRD STRAP
ENGINE TO BODY GRD

121-8 WHT
150-8 BLK
39 (LT9 ONLY)

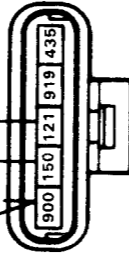

435 AIR SWITCH SOLENOID
919 AIR DIVER SOLENOID
121 TACHOMETER TO COIL
150 GROUND
900 IGNITION SWITCH
39

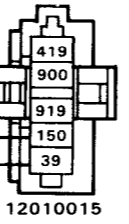

419 CHECK ENGINE
900 IGNITION
919 GROUND
150 IGNITION SW
39

TO CHECK ENGINE LP

SPLICE 39

I/P CLUSTER CONN.

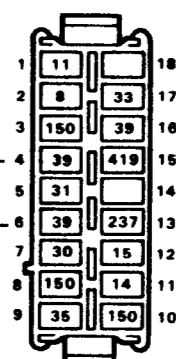

TO PARK BRAKE WARNING SW.

33-5 TAN/WHT

39-8 PNK/BLK

130-22 BRN/WHT

3-3-0 PNK

3-3-0 PNK

SPLICE 3

TO KICK DOWN SOL.

COWL

I/P

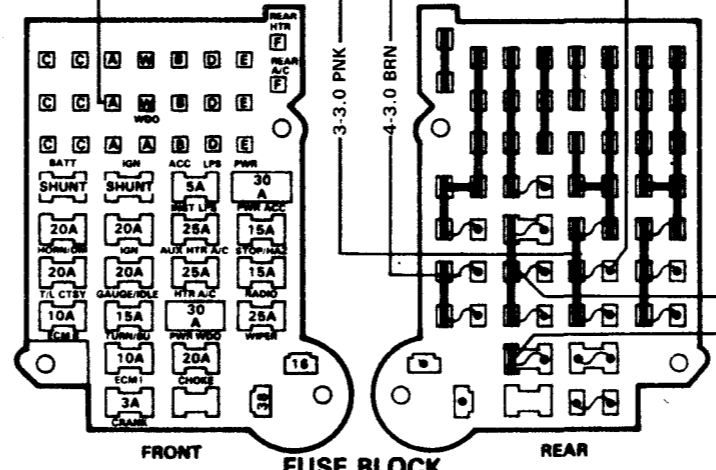
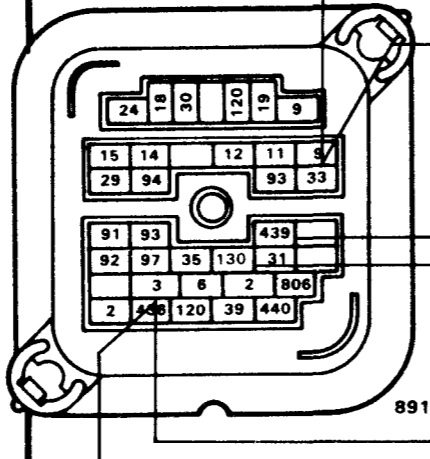

FRONT

REAR

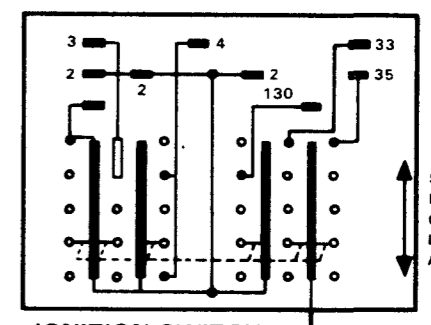
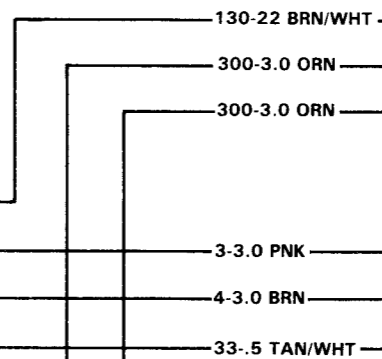

START
RUN
OFF
LOCK
ACC.

IGNITION L8, LT9-V8
SECTION D - PAGE 25

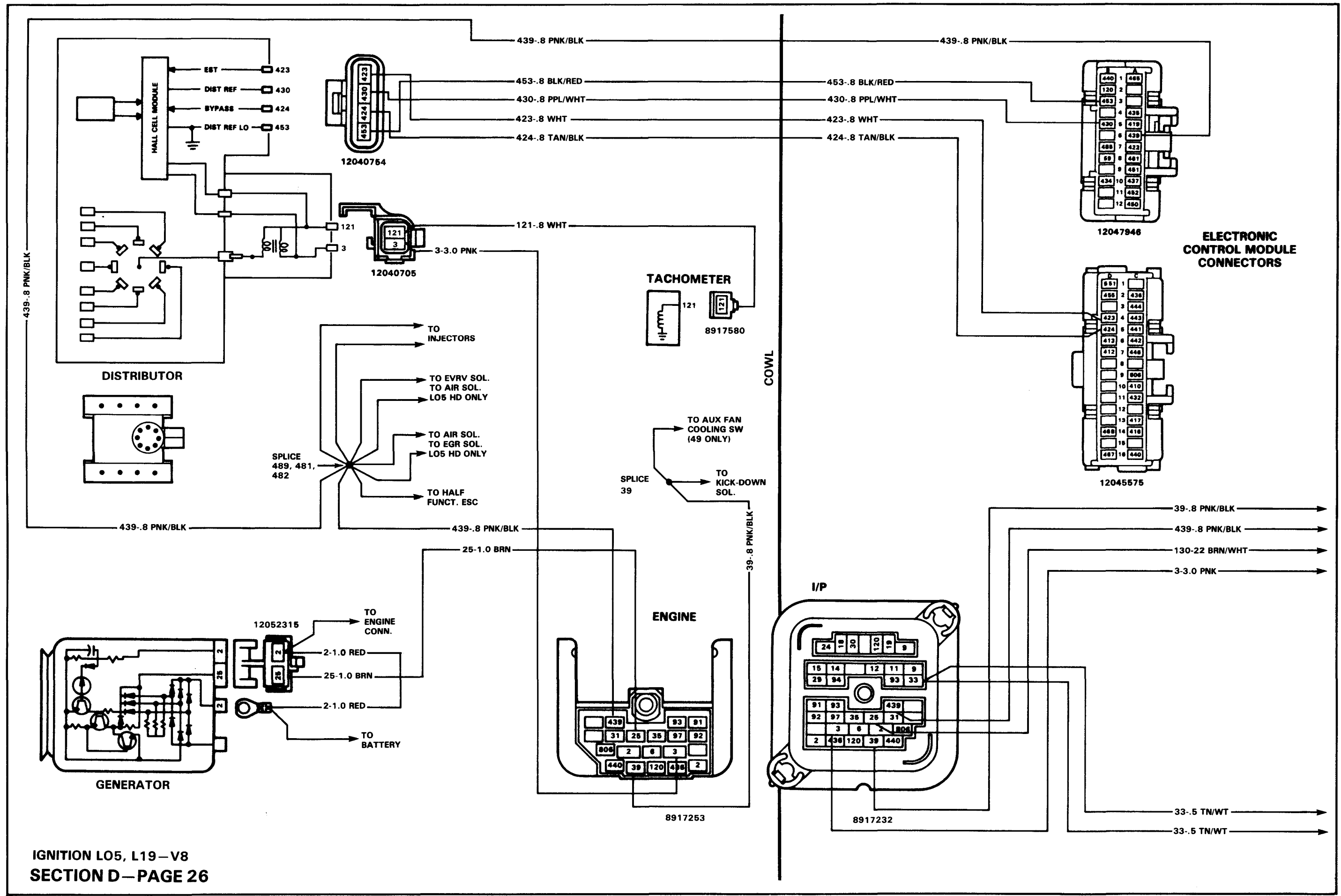

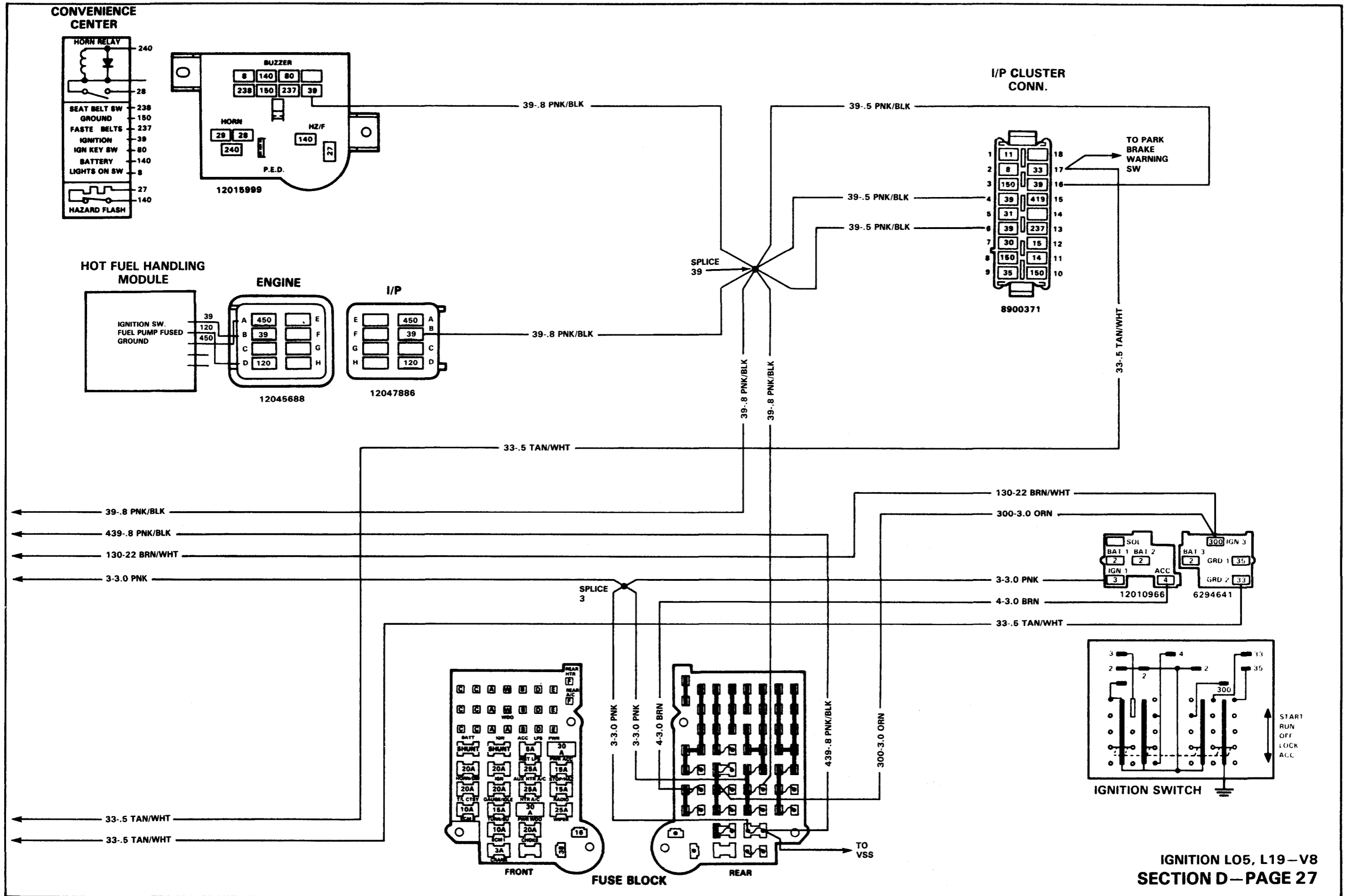

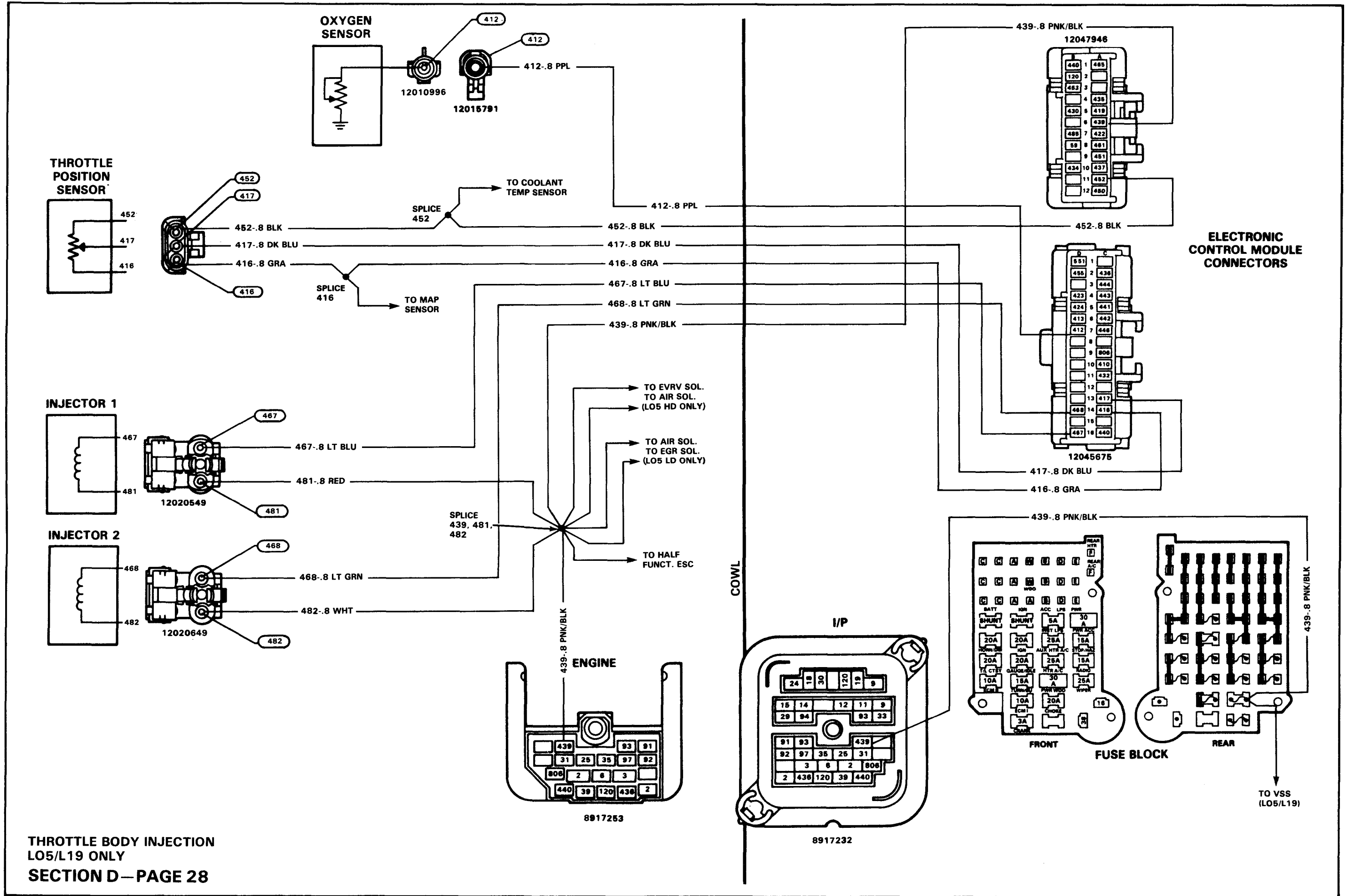

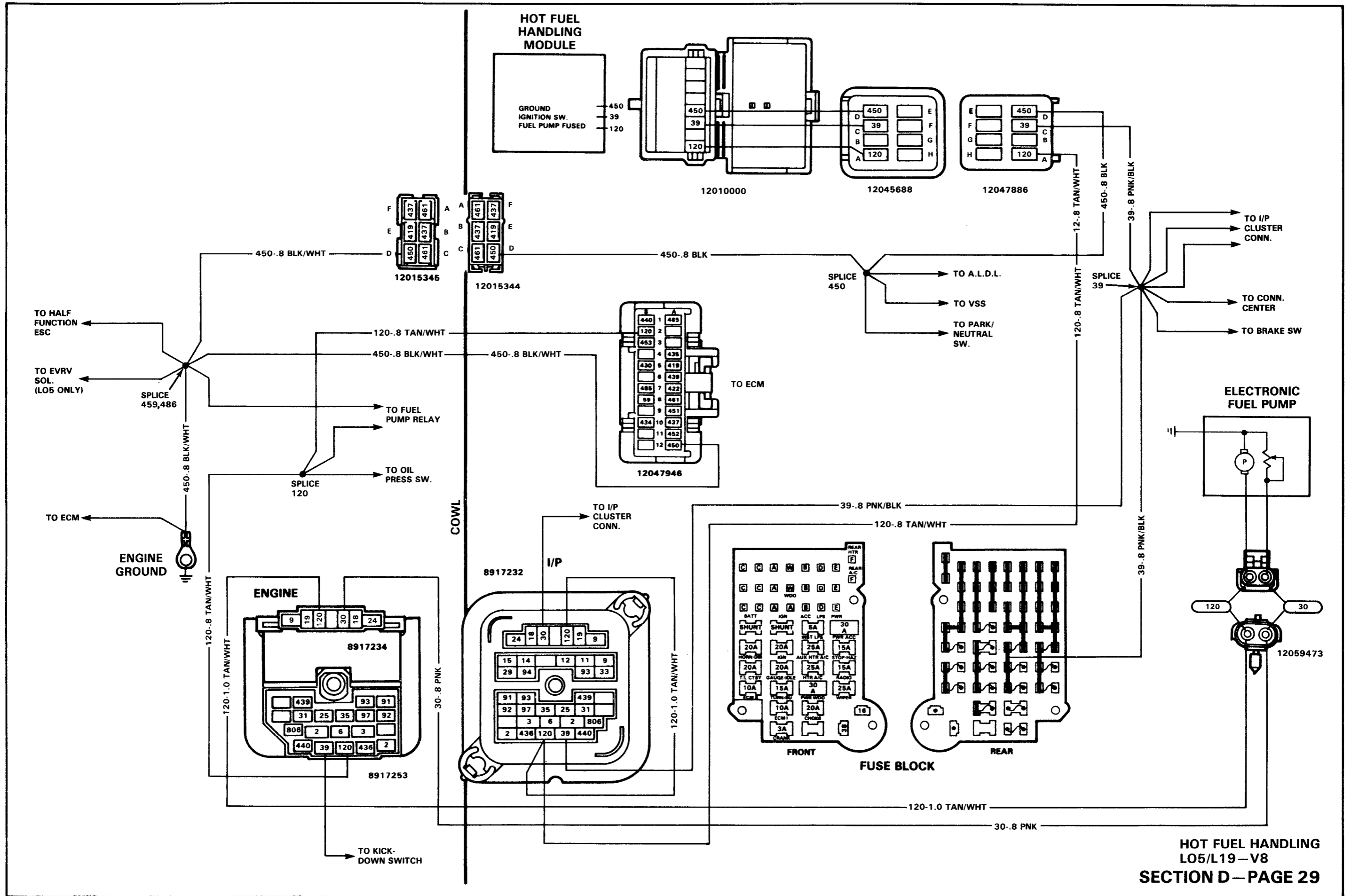

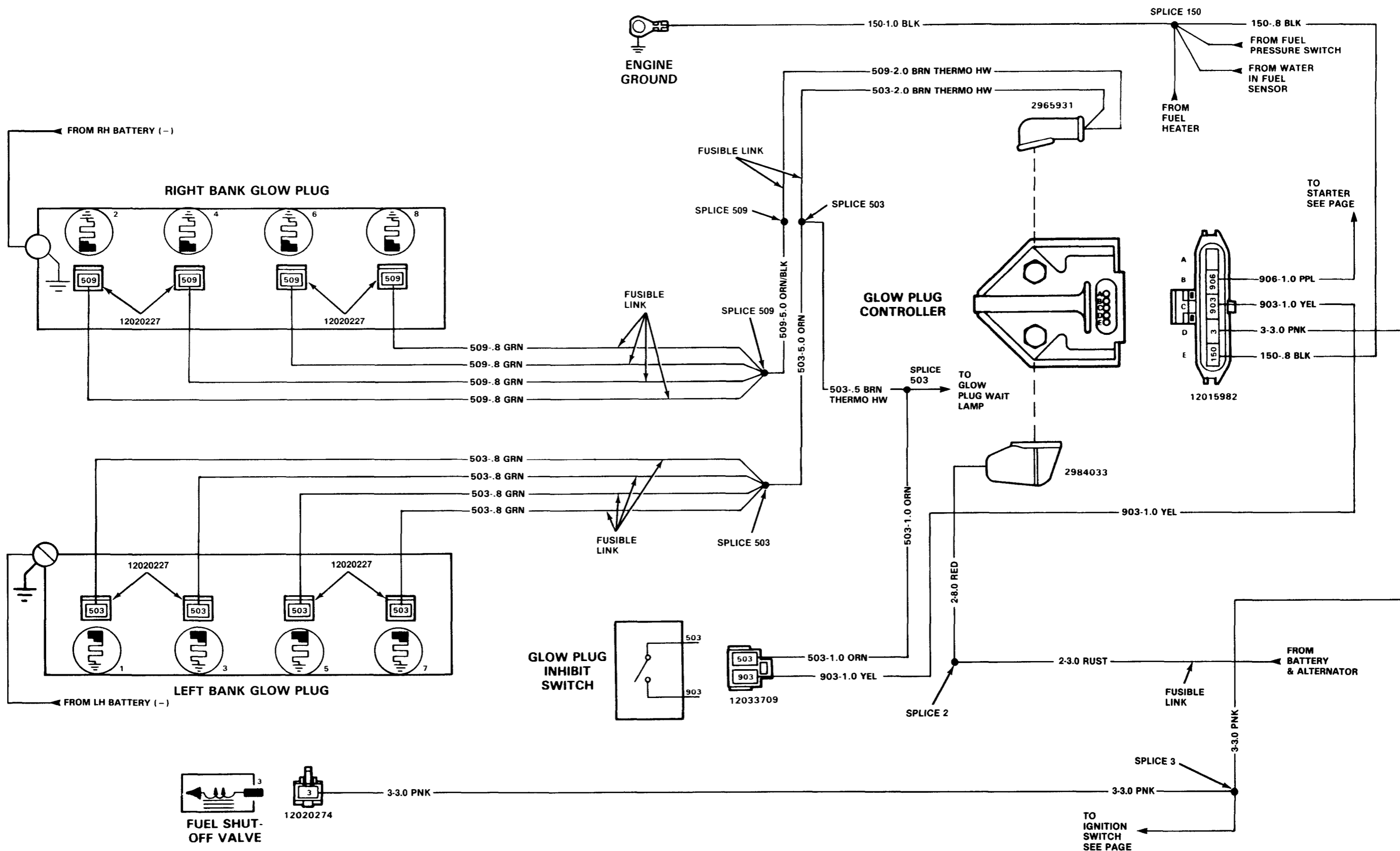

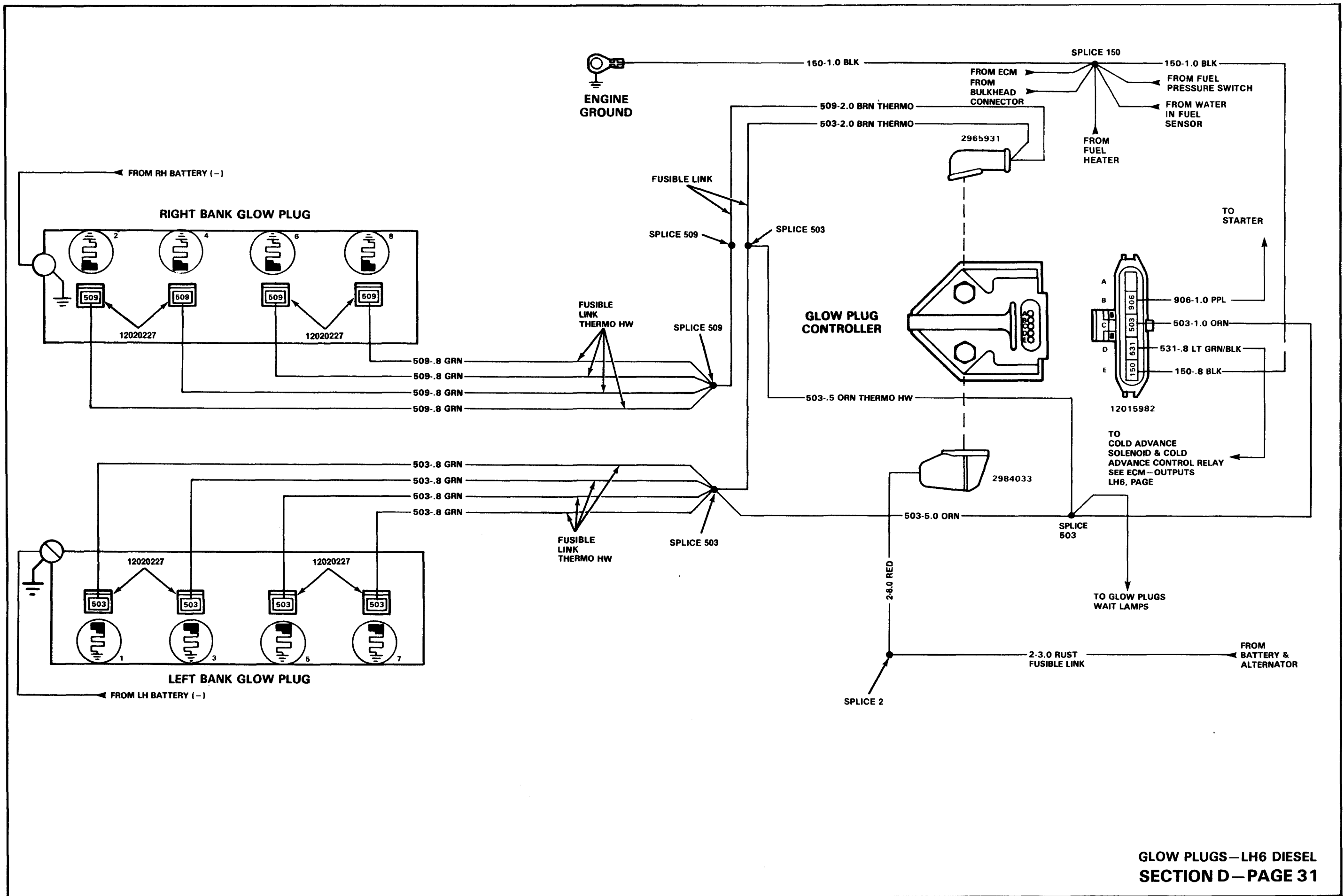

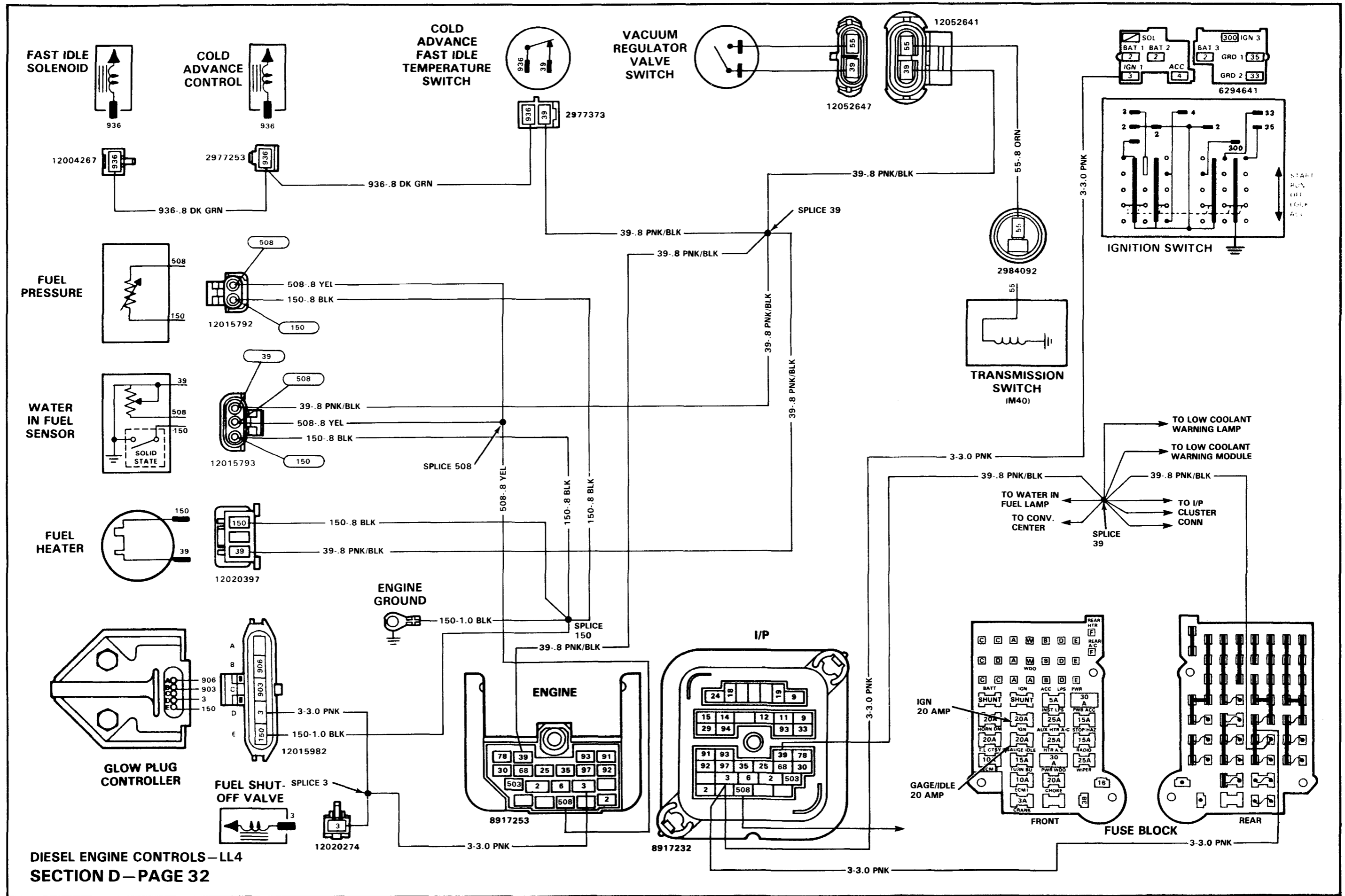

FAST IDLE SOLENOID

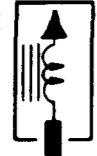

12004267

COLD ADVANCE CONTROL

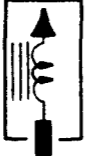

2977253

COLD ADVANCE FAST IDLE TEMPERATURE SWITCH



2977373

VACUUM REGULATOR VALVE SWITCH

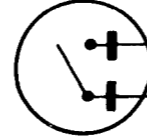

12052647

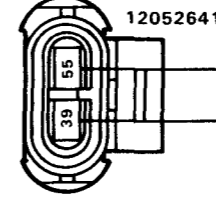

12052641

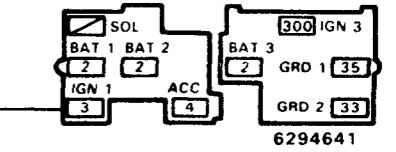

6294641

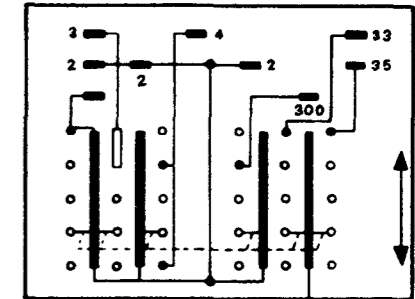

IGNITION SWITCH

FUEL PRESSURE

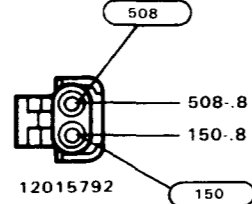
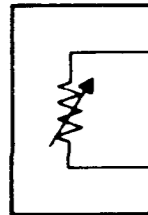

12015792

WATER IN FUEL SENSOR

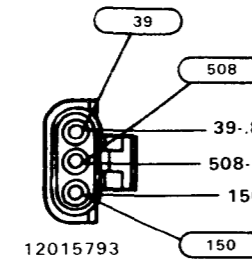
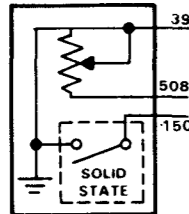

12015793

FUEL HEATER

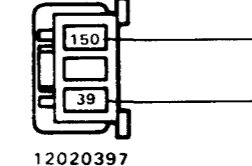
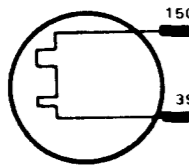

12020397

ENGINE GROUND

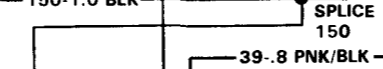

ENGINE

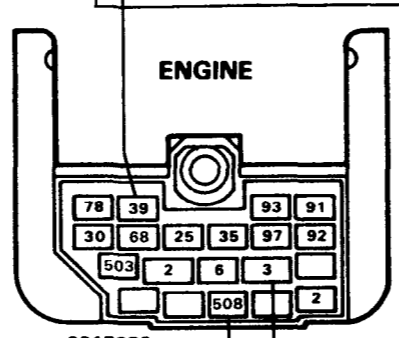

8917253

I/P

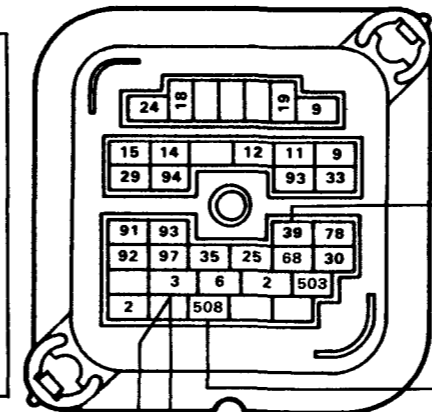

8917232

TRANSMISSION SWITCH (M40)

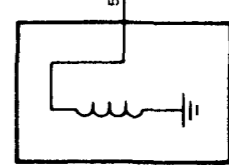

2984092

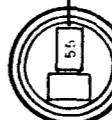

TRANSMISSION SWITCH (M40)

TO WATER IN FUEL LAMP
TO CONV. CENTER

SPICE 39

TO LOW COOLANT WARNING LAMP
TO LOW COOLANT WARNING MODULE

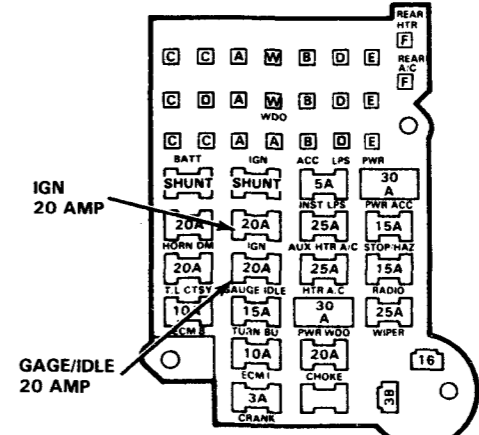

FRONT

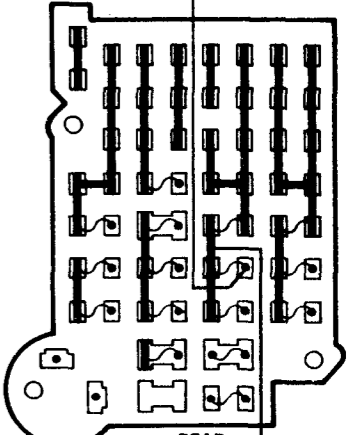

REAR

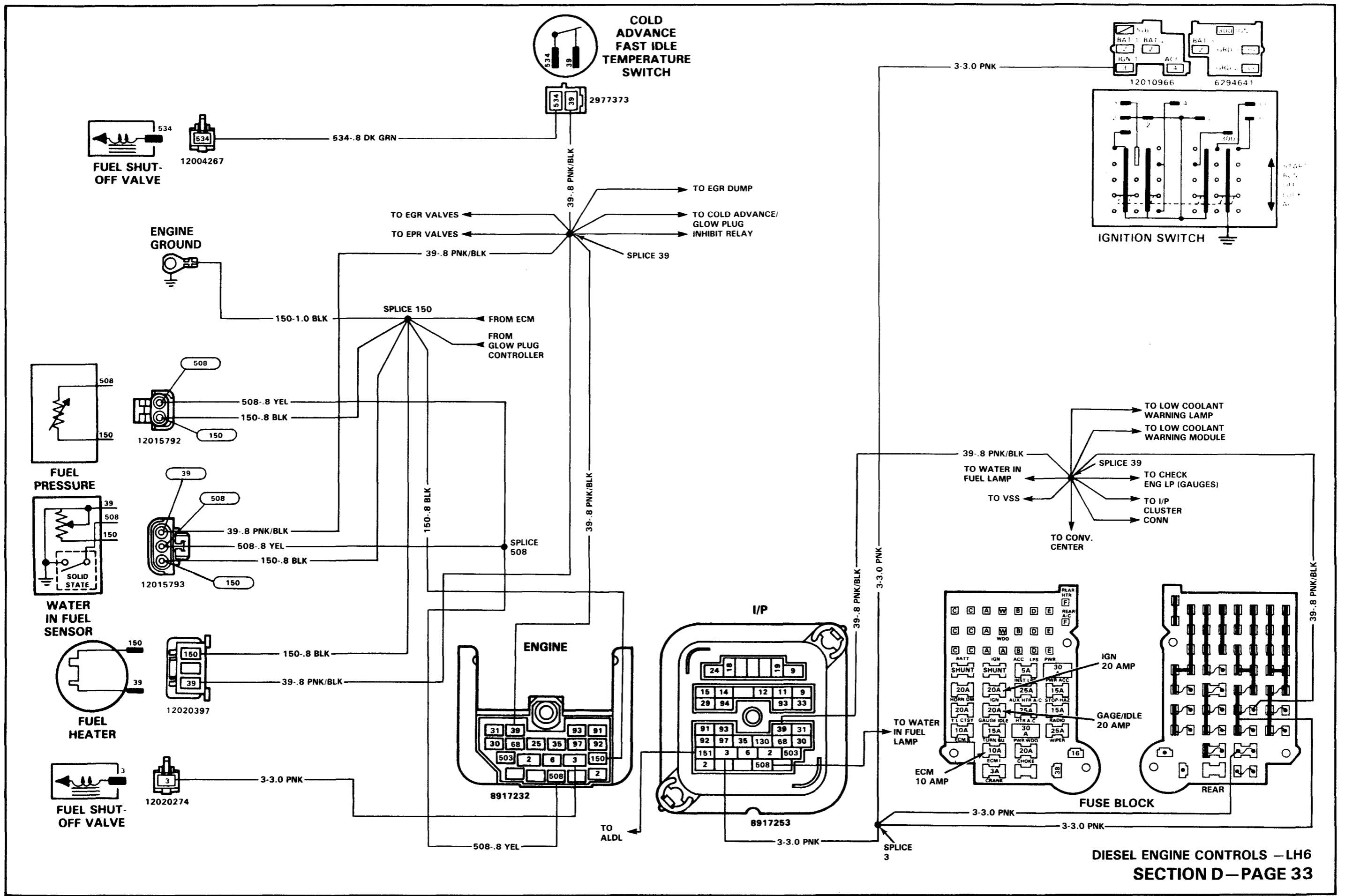

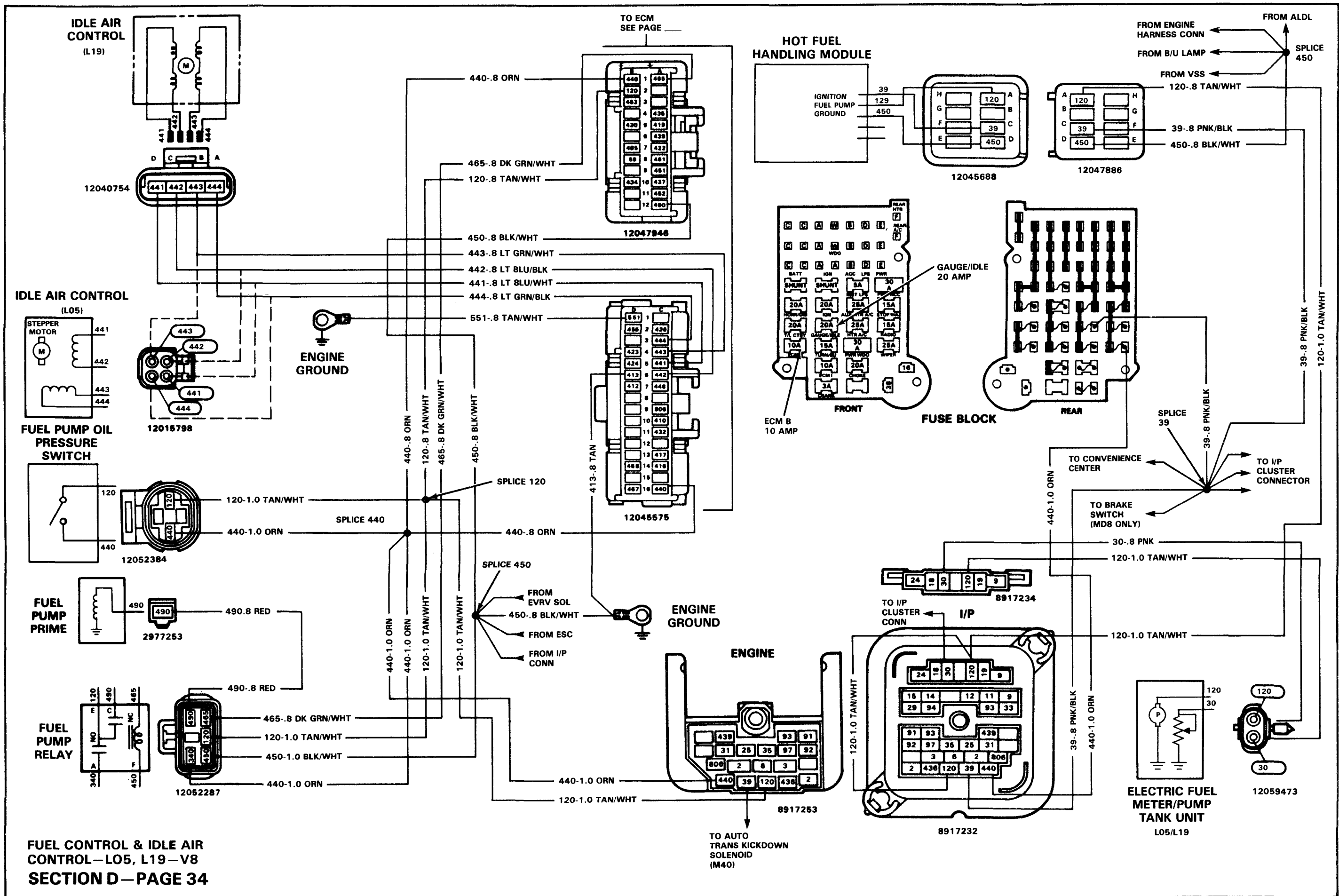

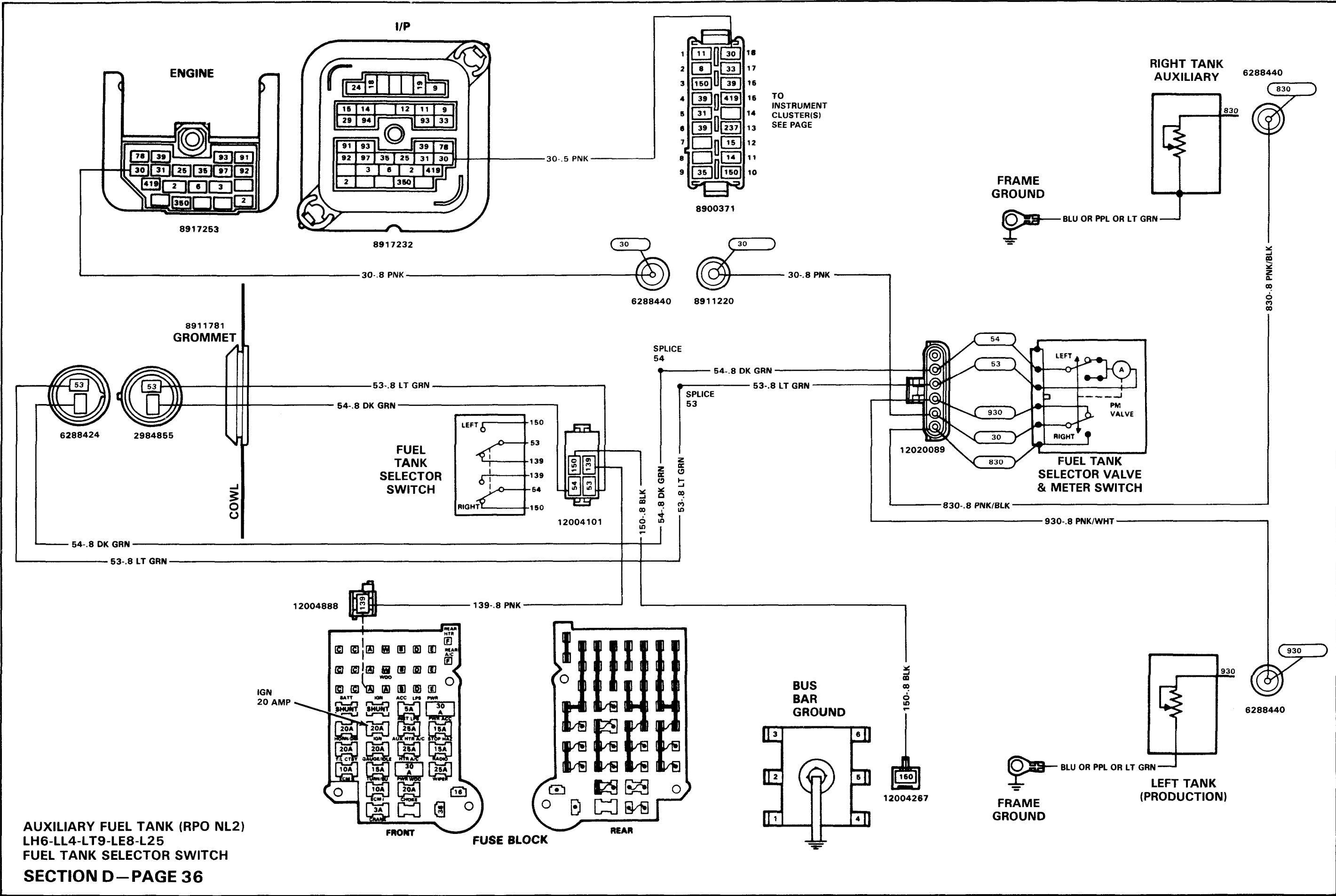

AUXILIARY FUEL TANK (RPO NL2)
 LH6-LL4-LT9-LE8-L25
 FUEL TANK SELECTOR SWITCH
 SECTION D—PAGE 36

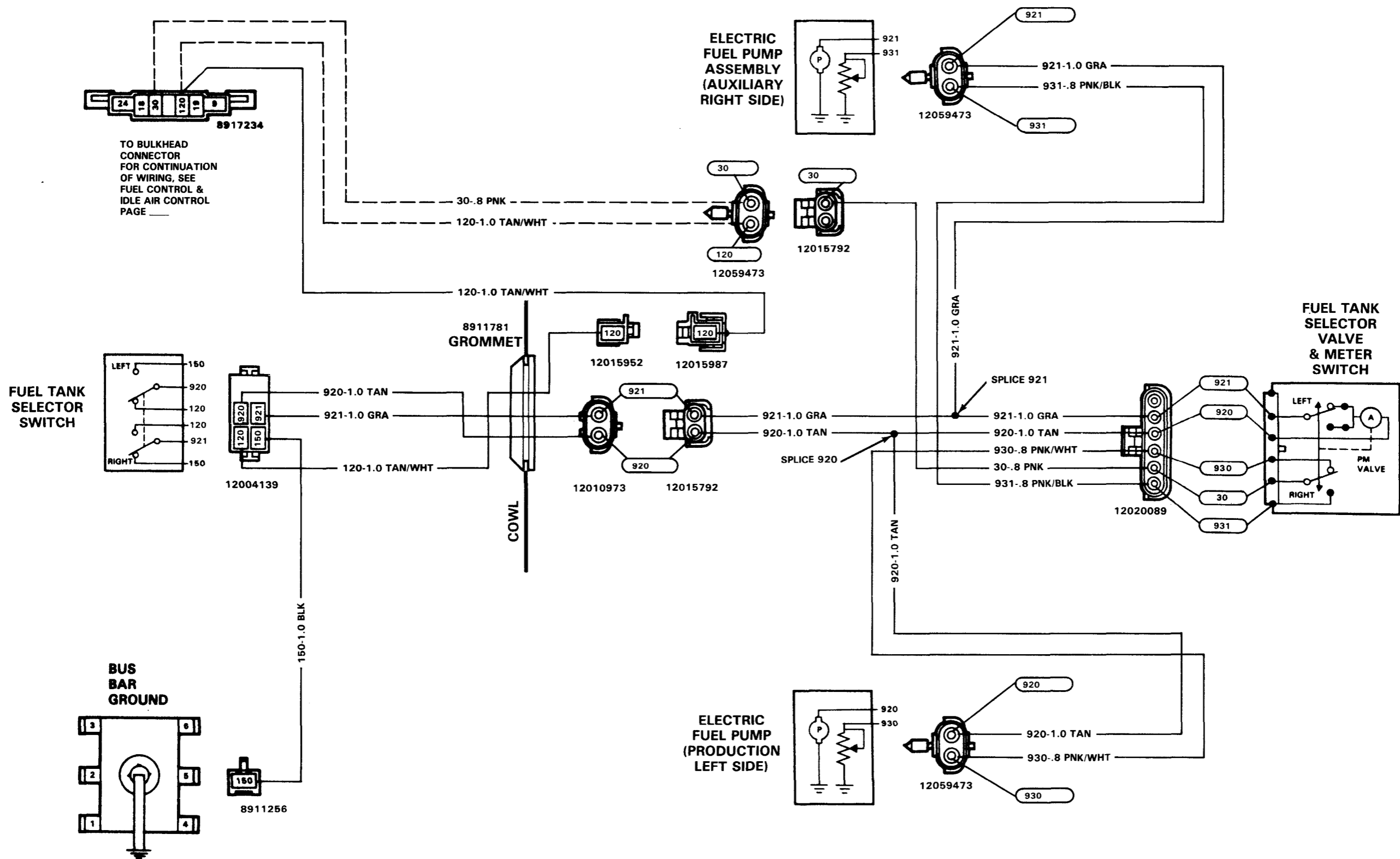

AUXILIARY FUEL TANK (RPO NL2)
 LO5-L19
 FUEL TANK SELECTOR SWITCH
 SECTION D—PAGE 37

RIGHT-HAND
AIR
DIVERT
SOLENOID

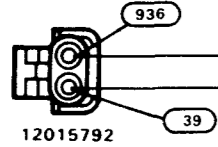
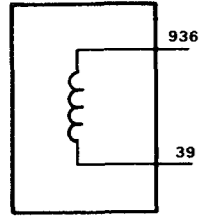

ENGINE
GROUND



4 GRD STRAP



ENGINE TO
BODY GRD

936-.8 YEL
39-.8 PNK/BLK

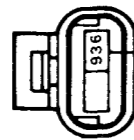

12040753

SPLICE 936

936-.8 YEL

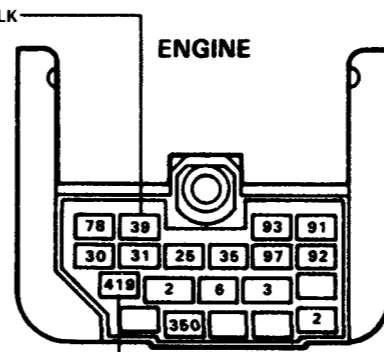

ENGINE

8917253

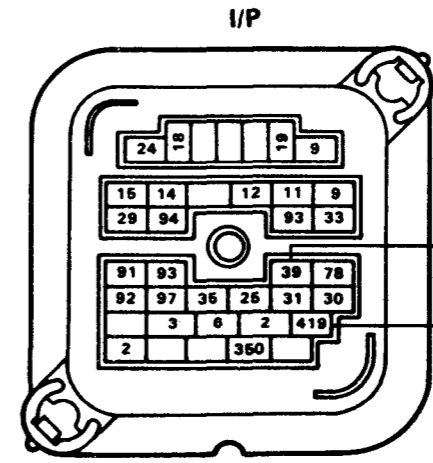

I/P

8917232

39-.8 PNK/BLK
TO CHECK
ENGINE
LAMP

AIR
CONTROLLER

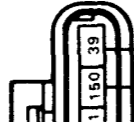
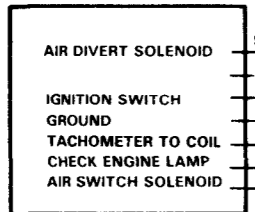

12040947

39-.8 PNK/BLK

150-.8 BLK

419-.8 BRN/WHT

419-.8 BRN/WHT

DISTRIBUTOR
CONNECTOR



8911979

121-.8 WHT

AIR
CLEANER
TEMP
SWITCH

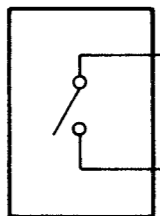

6288186

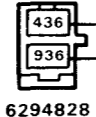

6294828

436-.5 BRN

936-.8 YEL

39-.8 PNK/BLK

IDLE
STOP
SOLENOID

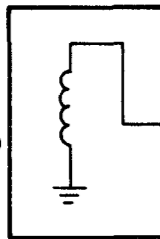

12015987

39-.8 PNK/BLK

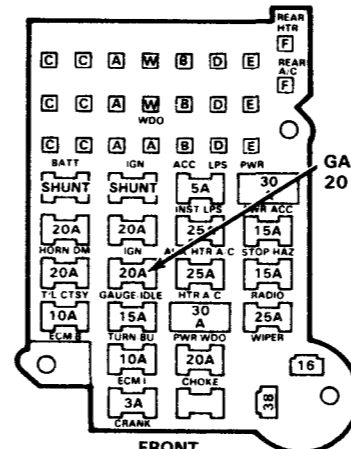

FRONT

FUSE BLOCK

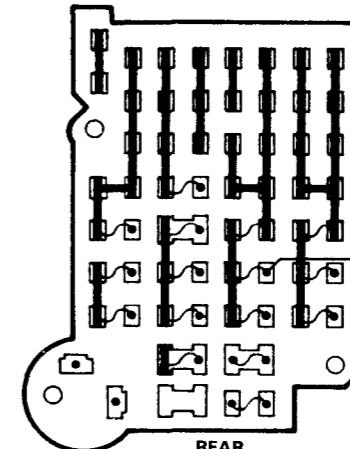

REAR

TO CHECK
ENGINE
LAMP

SPLICE 39

39-.8 PNK/BLK

TO I/P
CLUSTER
CONN

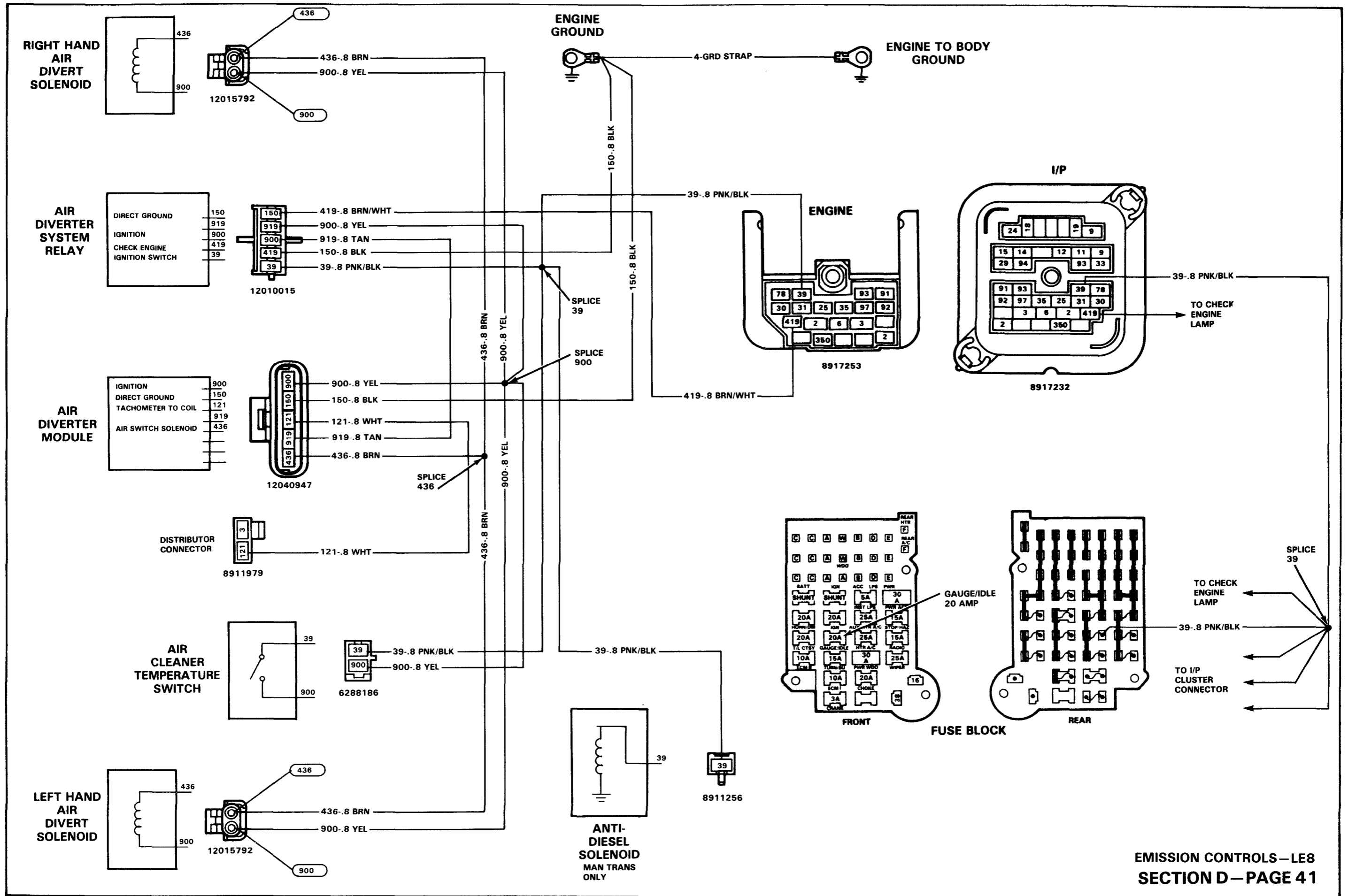

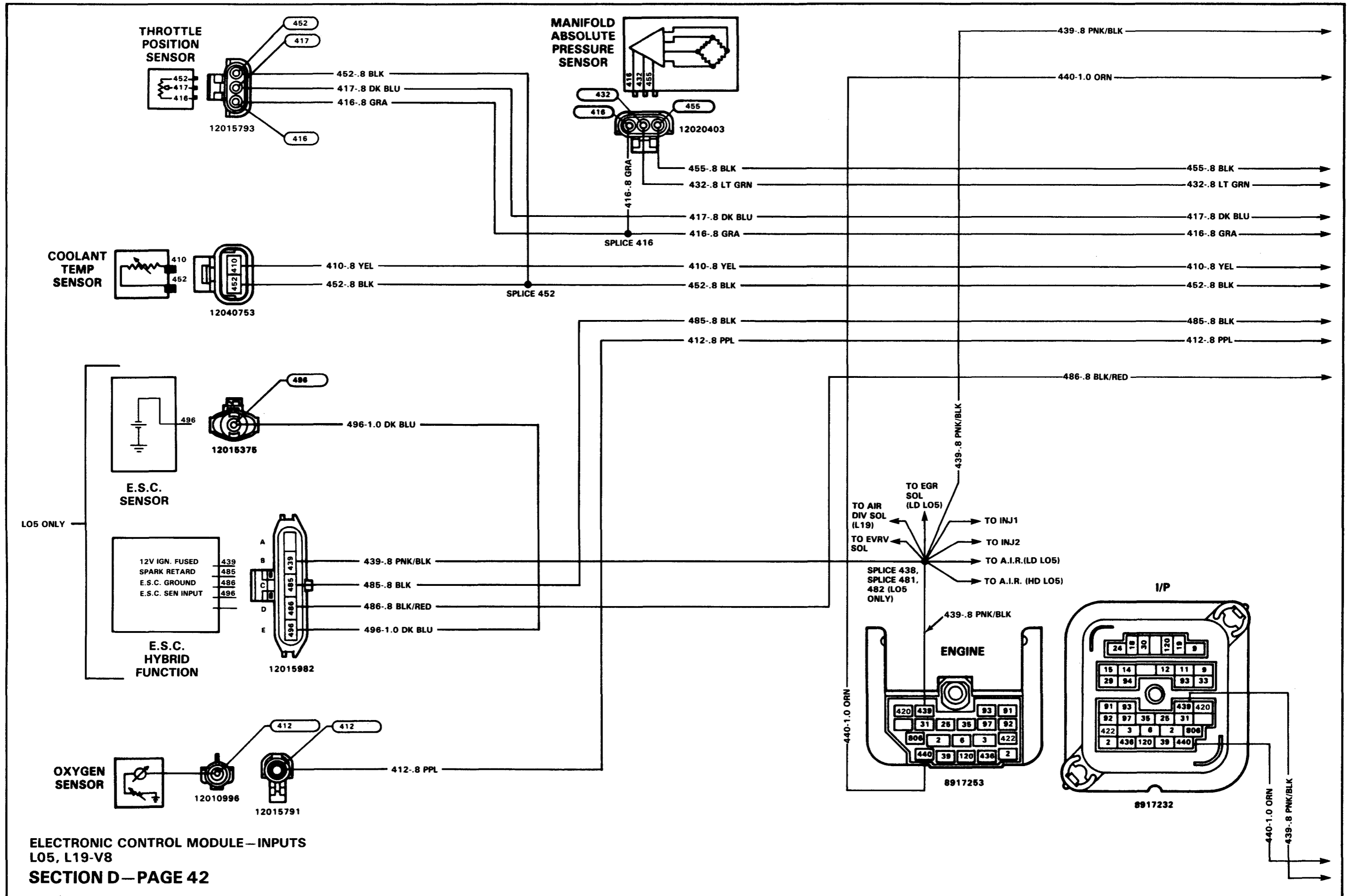

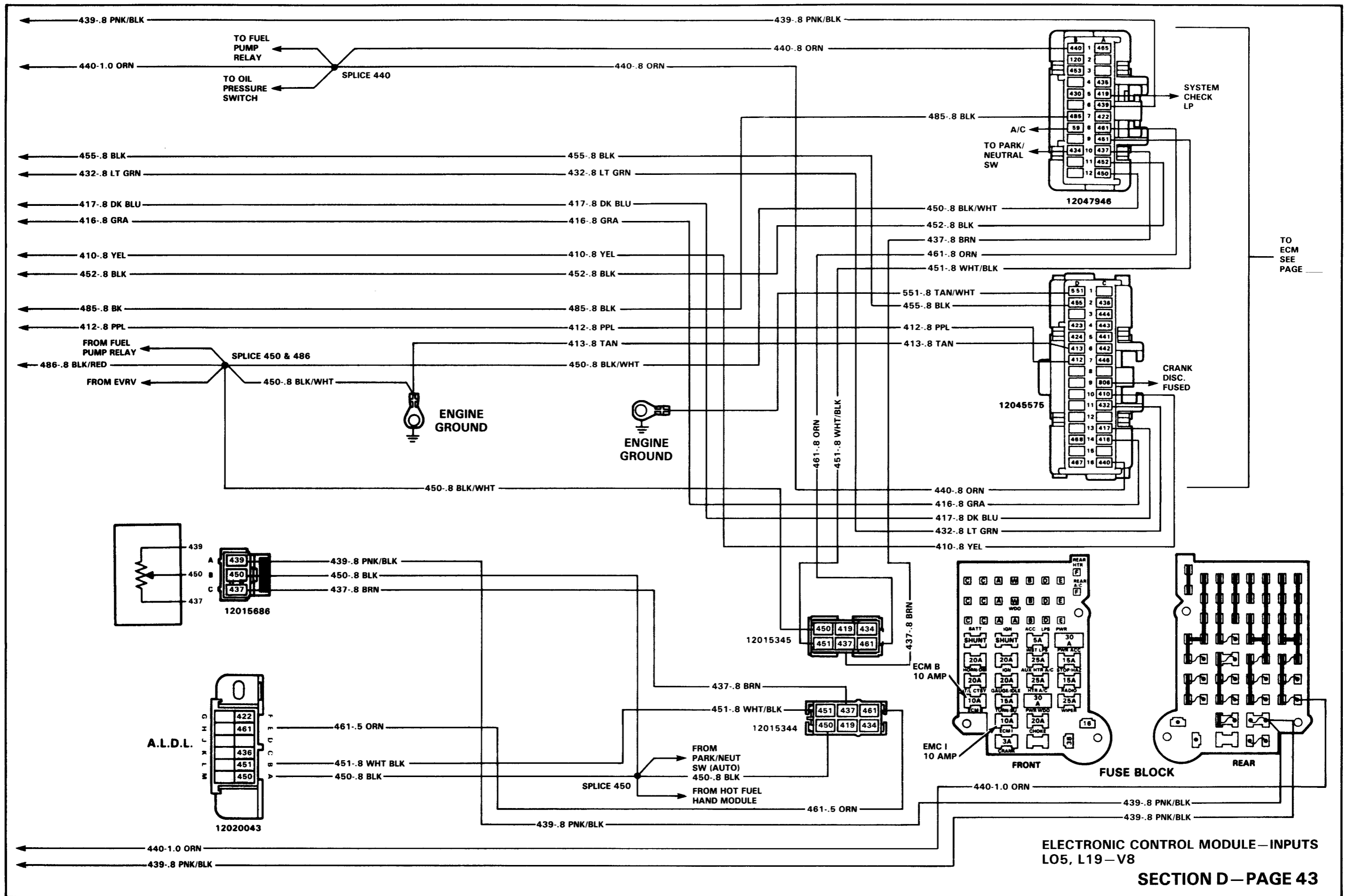

ELECTRONIC CONTROL MODULE—INPUTS
L05, L19—V8

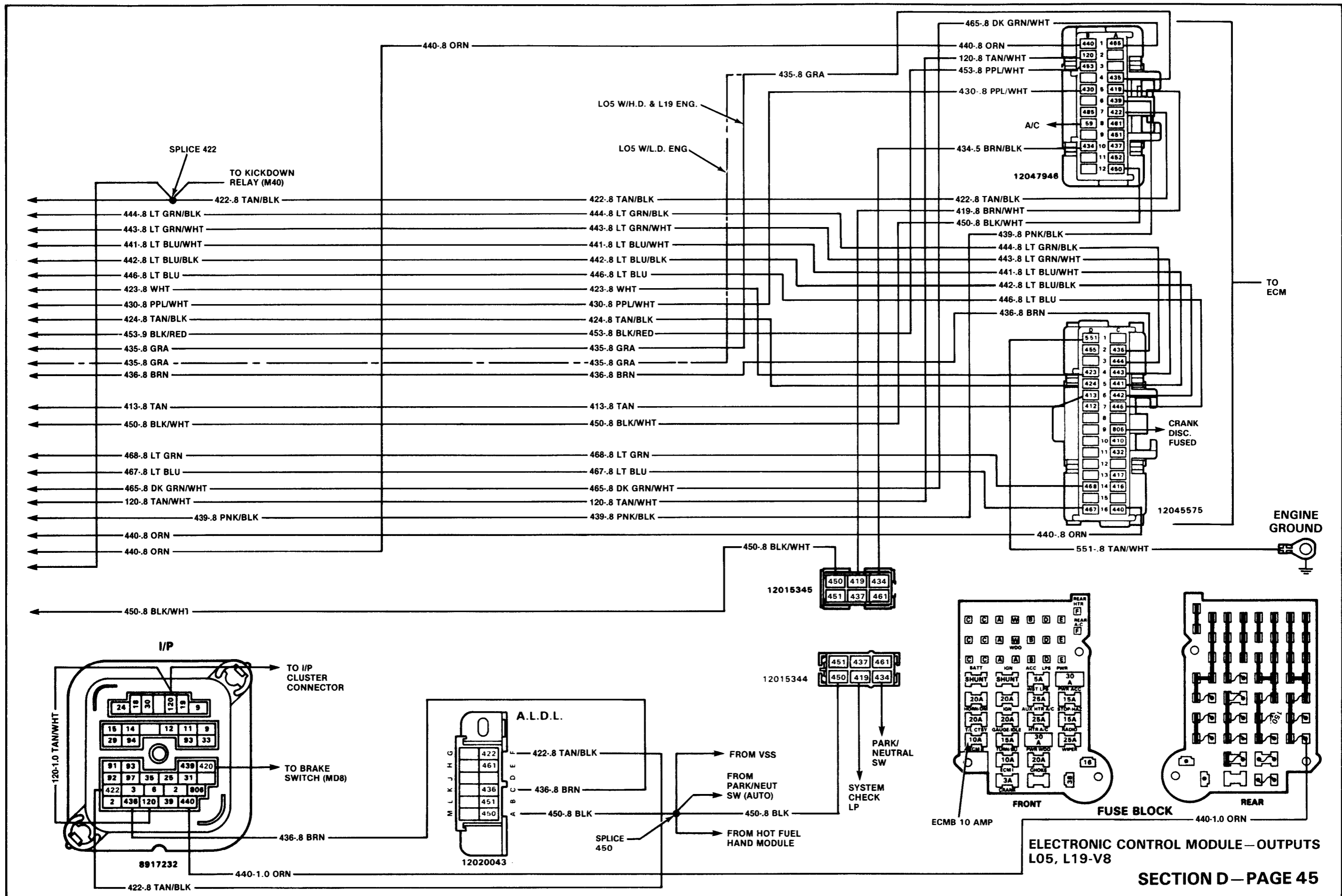

CIRCUIT NO.	WIRE SIZE	COLOR	CAVITY	DESCRIPTION
465	.8	DK GRN/WHT	A1	FUEL PUMP RELAY DRIVE
			A2	NOT USED
			A3	NOT USED
435	.8	GRA	A4	EGR SOLENOID
419	.8	BRN/WHT	A5	SYSTEM CHECK LAMP
439	.8	PNK/BLK	A6	12V IGNITION FUSED
* 422	.8	TAN/BLK	A7	TORQUE CONVERTER CLUTCH
461	.8	ORN	A8	SERIAL DATA
451	.8	WHT/BLK	A9	ASS'Y LINE DIAG./LINK
437	.8	BRN	A10	SPEED SENSOR
452	.8	BLK	A11	5V RETURN B
450	.8	BLK/WHT	A12	SYSTEM RETURN
440	.8	ORN	B1	12V BATTERY FUSED
120	.8	TAN/WHT	B2	ELEC FUEL PUMP FUSED FEED
453	.8	BLK/RED	B3	DISTRIBUTOR REF LOW
			B4	NOT USED
430	.8	PPL/WHT	B5	DISTRIBUTOR REF HIGH
			B6	NOT USED
● 485	.8	BLK	B7	SPARK RETARD CONTROL
59	.8	DK GRN	B8	AIR CONDITION
			B9	NOT USED
* 434	.5	ORN/BLK	B10	PARK/NEUTRAL SWITCH
			B11	NOT USED
			B12	NOT USED

* AUTO TRANS ONLY

● L05 ONLY

CIRCUIT NO.	WIRE SIZE	COLOR	CAVITY	DESCRIPTION
			C1	NOT USED
436	.8	BRN	C2	AIR SWITCH SOLENOID
444	.8	LT GRN/BLK	C3	STEPPER COIL B LOW
443	.8	LT GRN/WHT	C4	STEPPER COIL B HIGH
441	.8	LT BLU/WHT	C5	STEPPER COIL A HIGH
442	.8	LT BLU/BLK	C6	STEPPER COIL A LOW
* 446	.8	LT BLU	C7	A/C CONTROL (4TH GEAR DISCRETE)
			C8	NOT USED
806	.8	PPL/WHT	C9	CRANK DISCRETE FUSED
410	.8	YEL	C10	COOLANT TEMPERATURE
432	.8	LT GRN	C11	MANIFOLD ABSOLUTE PRESS.
			C12	NOT USED
417	.8	DK BLU	C13	THROTTLE POSITION SENSOR
416	.8	GRA	C14	5V SENSOR REFERENCE
			C15	NOT USED
440	.8	ORN	C16	12V BATTERY FUSED
551	.8	TAN/WHT	D1	SYSTEM GROUND
455	.8	PPL	D2	5V RETURN A
			D3	NOT USED
423	.8	WHT	D4	HEI SPARK TIMING
424	.8	TAN/BLK	D5	HEI BYPASS
413	.8	TAN	D6	OXYGEN SENSOR LOW
412	.8	PPL	D7	OXYGEN SENSOR HIGH
			D8	NOT USED
			D9	NOT USED
			D10	NOT USED
			D11	NOT USED
			D12	NOT USED
			D13	NOT USED
468	.8	LT GRN	D14	INJECTOR B DRIVE
			D15	NOT USED
467	.8	LT BLU	D16	INJECTOR A DRIVE

* AUTO TRANS ONLY

● L05 ONLY

CIRCUIT NO.	WIRE SIZE	COLOR	CAVITY	DESCRIPTION
432	.8	LT GRN	A1	MANIFOLD ABSOLUTE PRESS
417	.8	DK BLU	A2	THROTTLE POSITION SWITCH
410	.8	YEL	A3	COOLANT TEMP. SENSOR
			A4	NOT USED
			A5	NOT USED
451	.8	WHT/BLK	A6	ASS'Y LINE DIAG./LINK
			A7	NOT USED
121	.8	WHT	A8	ENGINE SPEED SENSOR
437	.8	BRN	A9	VEHICLE SPEED SENSOR
488	.8	LT GRN	A10	ASS'Y LINE DIAG./LINK
			A11	NOT USED
416	.8	GRA	A12	THROTTLE POSITION SWITCH & MANIFOLD ABSOLUTE PRESS.
			B1	NOT USED
			B2	NOT USED
			B3	NOT USED
			B4	NOT USED
			B5	NOT USED
			B6	NOT USED
			B7	NOT USED
			B8	NOT USED
			B9	NOT USED
			B10	NOT USED
			B11	NOT USED
			B12	NOT USED

CIRCUIT NO.	WIRE SIZE	COLOR	CAVITY	DESCRIPTION
452	.8	BLK	C1	SYSTEM RETURN
150	.8	BLK	C2	SYSTEM GROUND
			C3	NOT USED
			C4	NOT USED
* 422	.8	TAN/BLK	C5	TORQUE CONVERTER CLUTCH
905	.8	BRN	C6	COLD ADVANCE/GLOW PLUG INHIBIT RELAY
			C7	NOT USED
			C8	NOT USED
			C9	NOT USED
435	.5	GRA	C10	EGR DIAGNOSTIC CONNECTOR
902	.8	LT BLU	C11	EGR SOLENOID
538	.8	DK GRN	C12	EPR SOLENOID
			C13	NOT USED
439	.8	PNK/BLK	C14	12V IGNITION FUSED
			C15	NOT USED
440	.8	ORN	C16	12V BATTERY FUSED
			D1	NOT USED
			D2	NOT USED
			D3	NOT USED
			D4	NOT USED
			D5	NOT USED
			D6	NOT USED
			D7	NOT USED
			D8	NOT USED
			D9	NOT USED
			D10	NOT USED
			D11	NOT USED
			D12	NOT USED
			D13	NOT USED
			D14	NOT USED
			D15	NOT USED
			D16	NOT USED

* AUTO TRANS ONLY

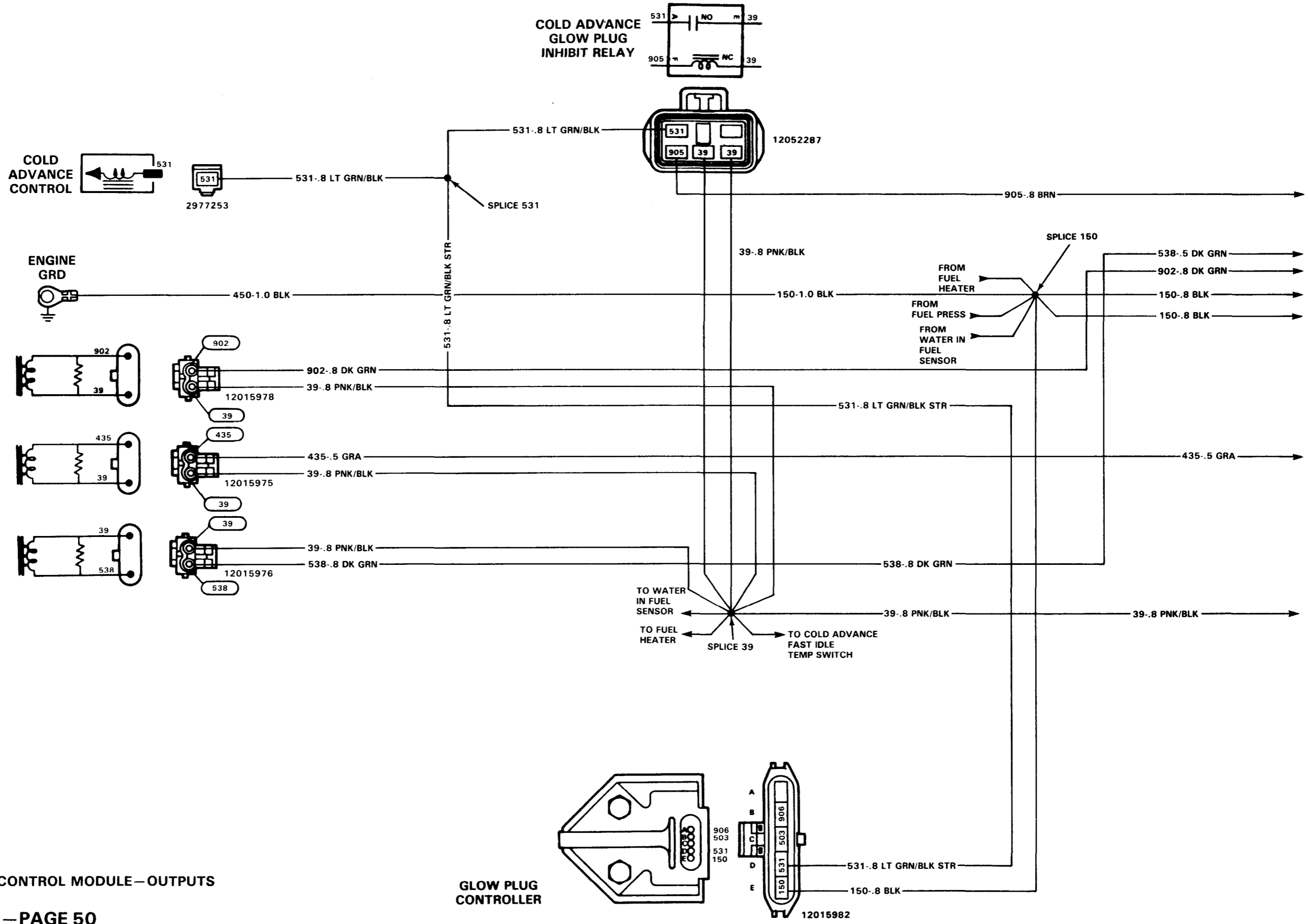

ELECTRONIC CONTROL MODULE—OUTPUTS
 LH6 DIESEL
 SECTION D—PAGE 50

GLOW PLUG
 CONTROLLER

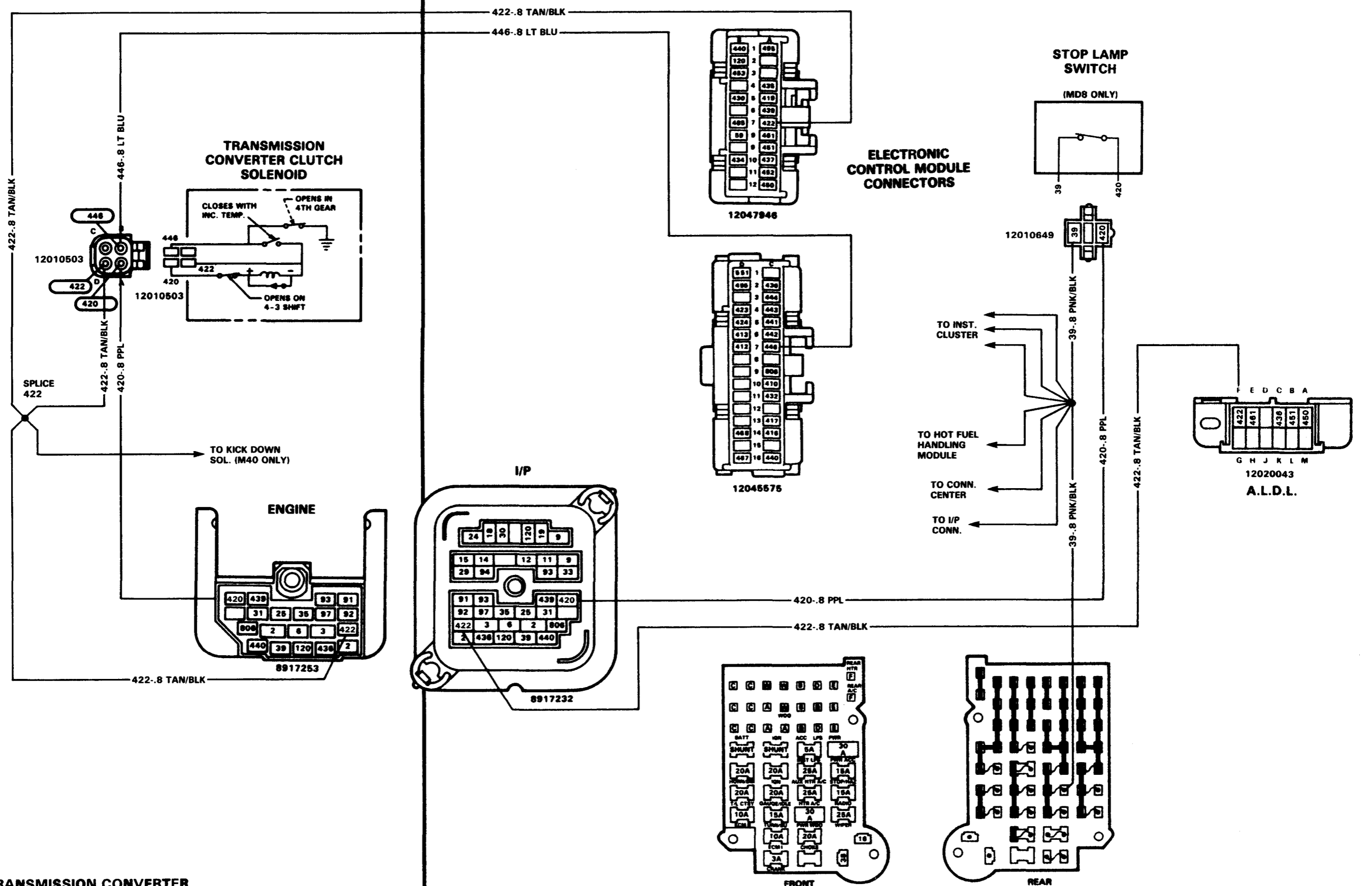
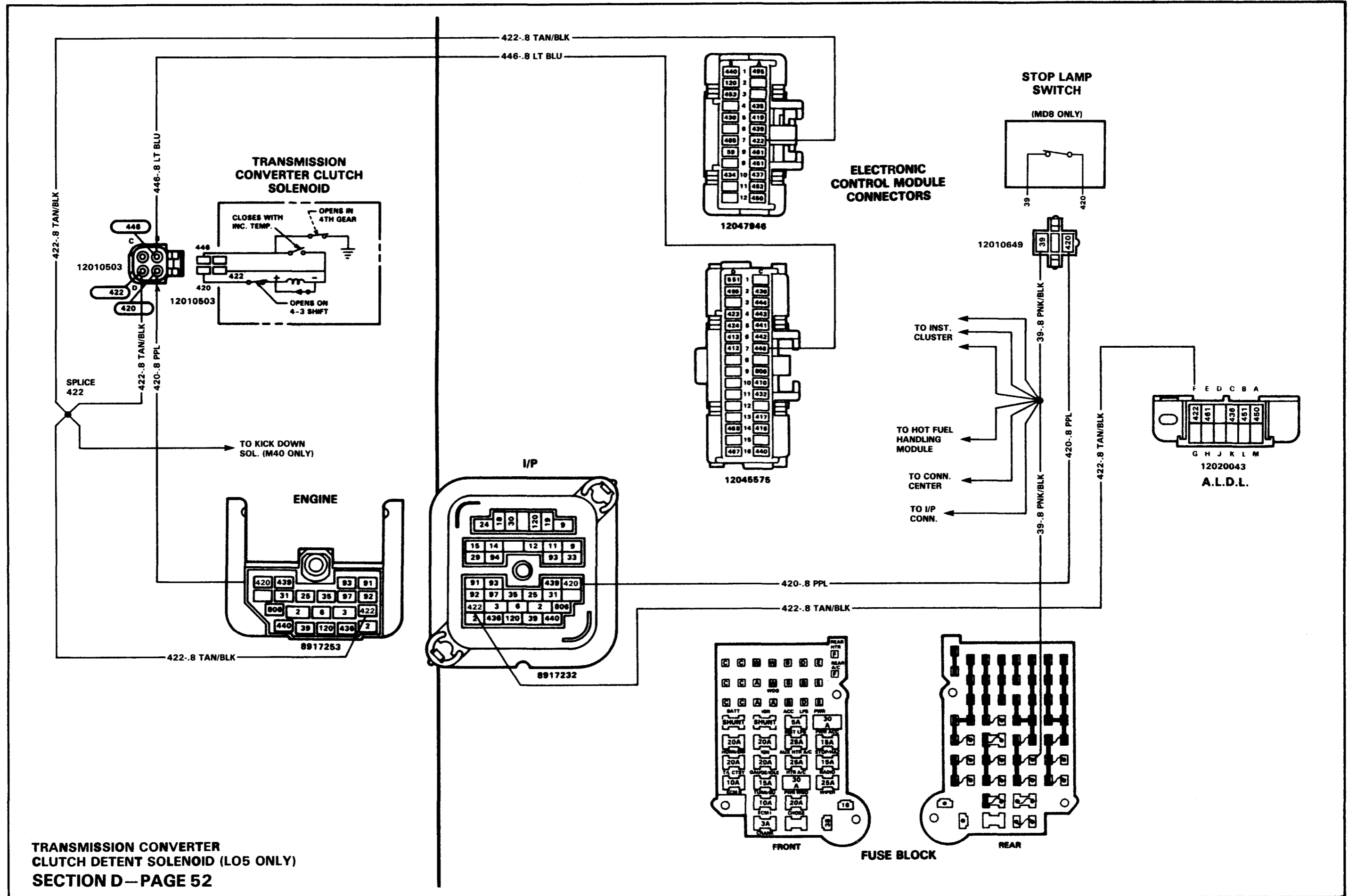

TRANSMISSION CONVERTER CLUTCH DETENT SOLENOID (LO5 ONLY)
SECTION D—PAGE 52

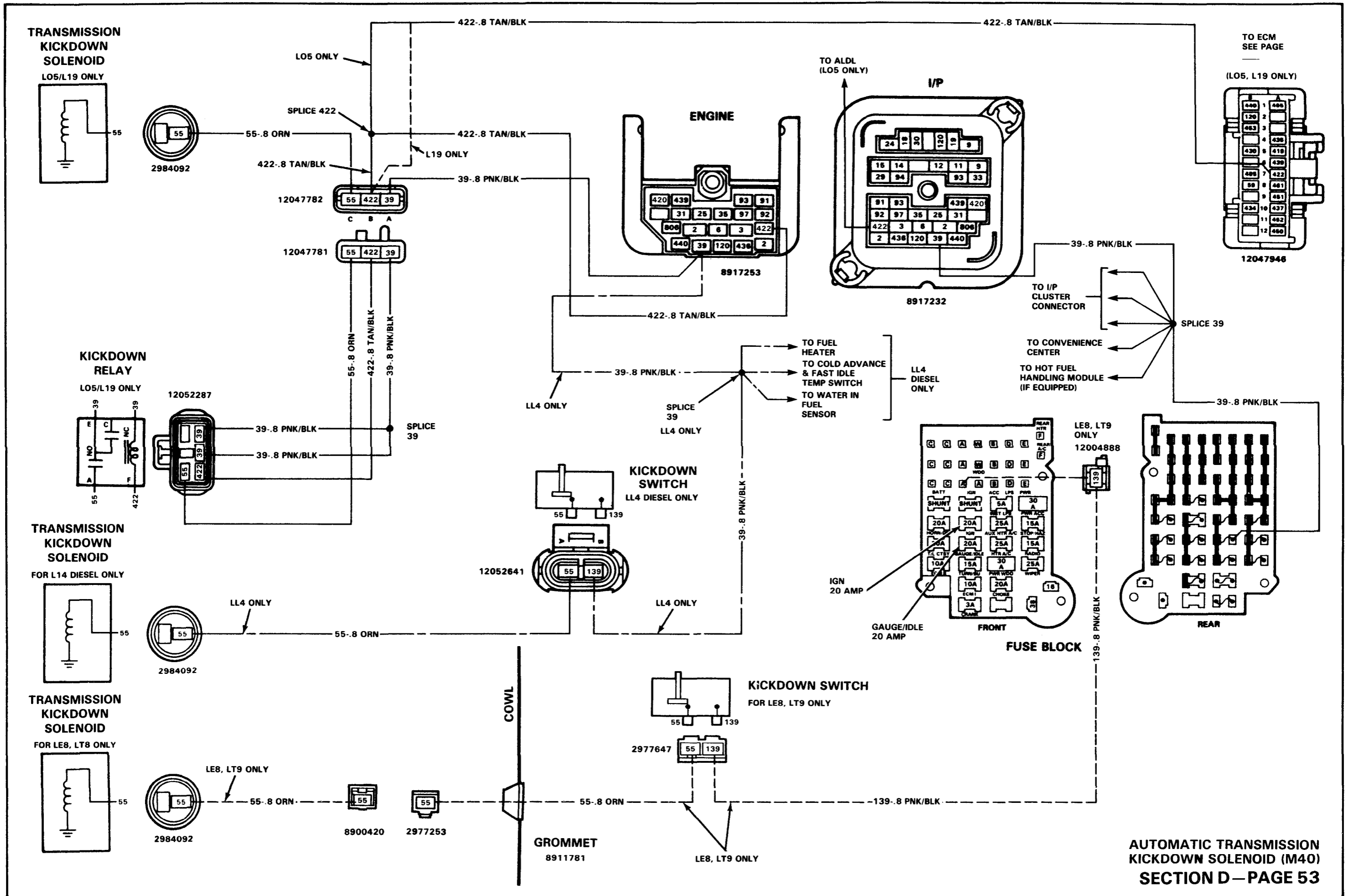

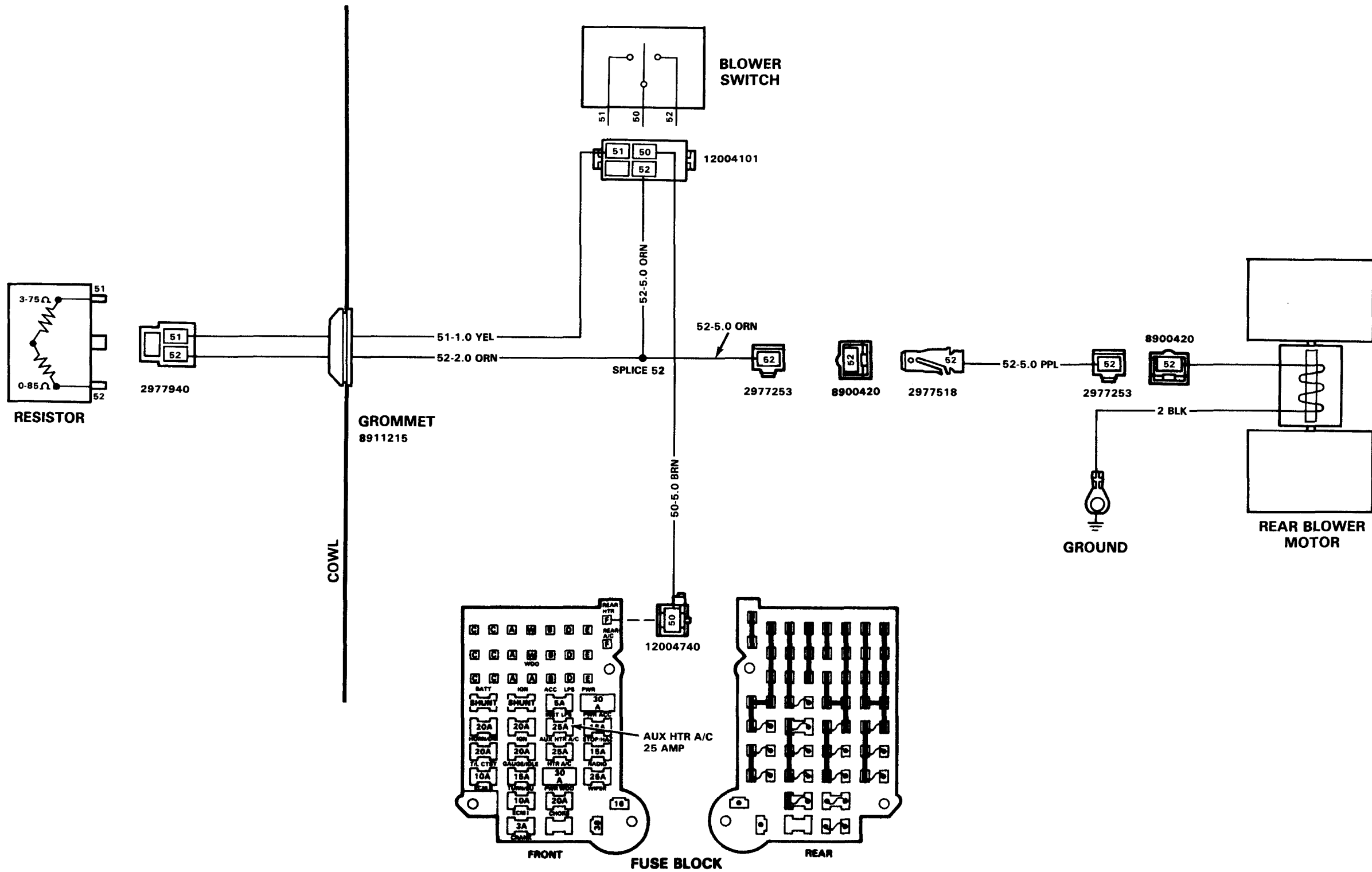

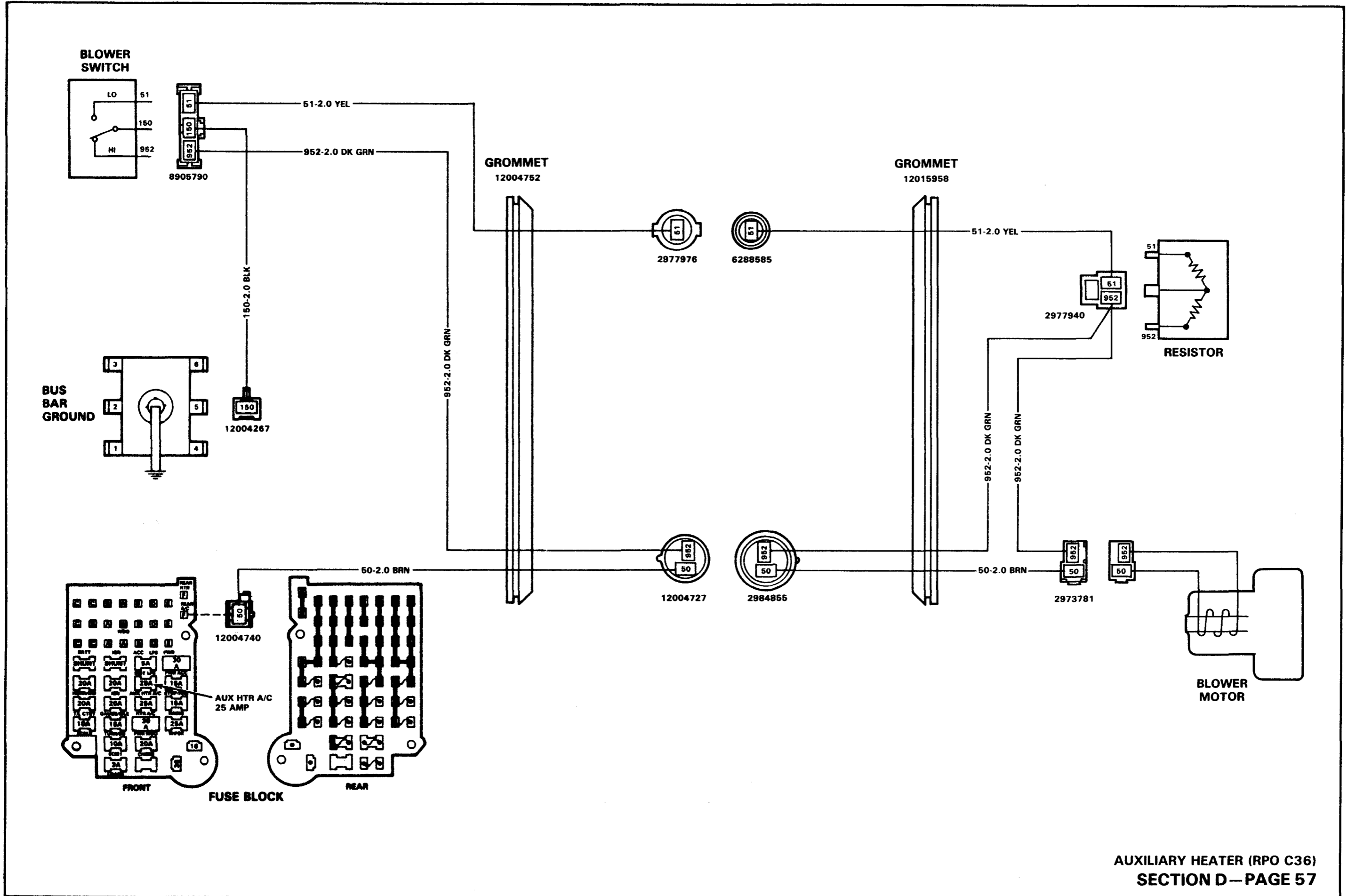

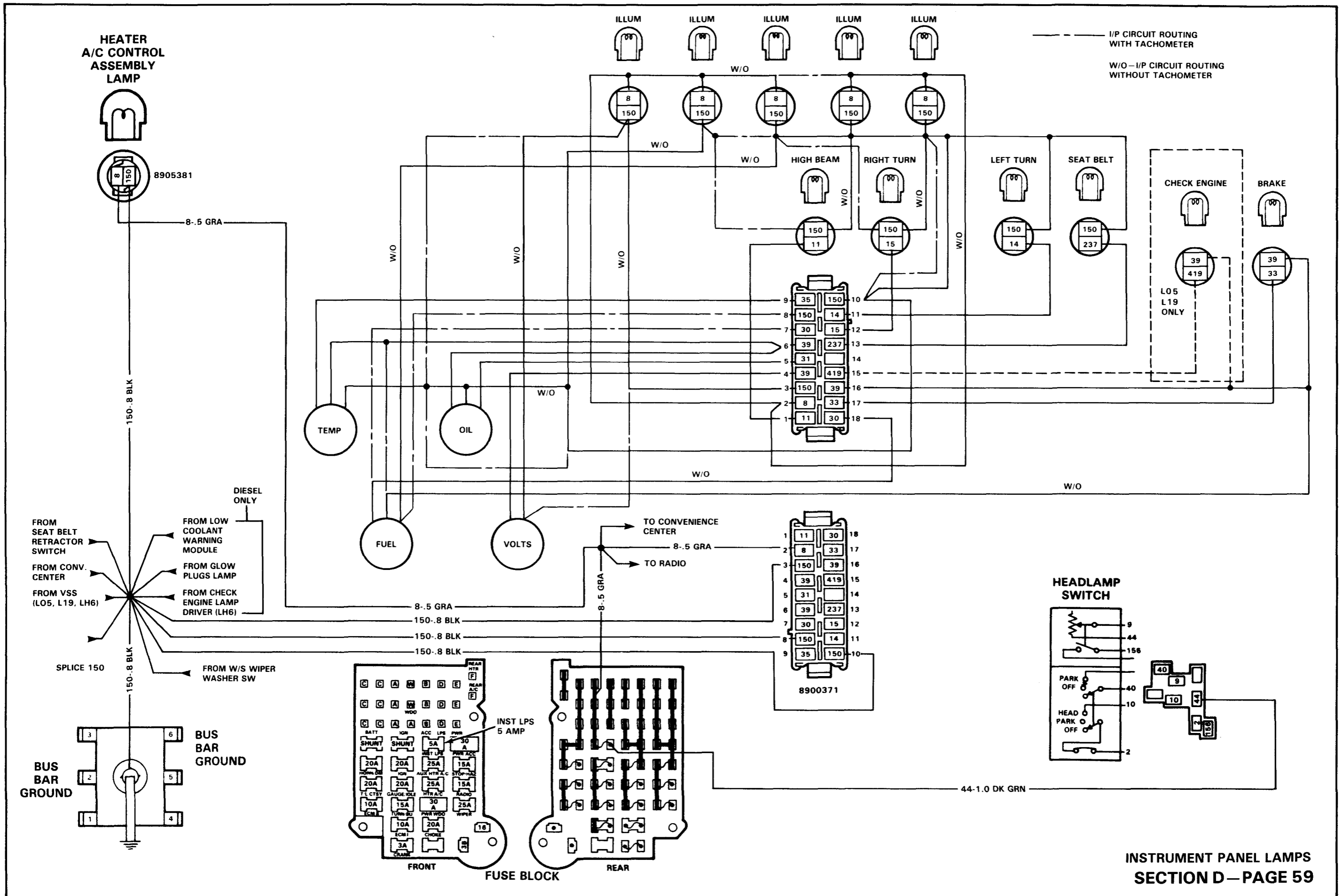

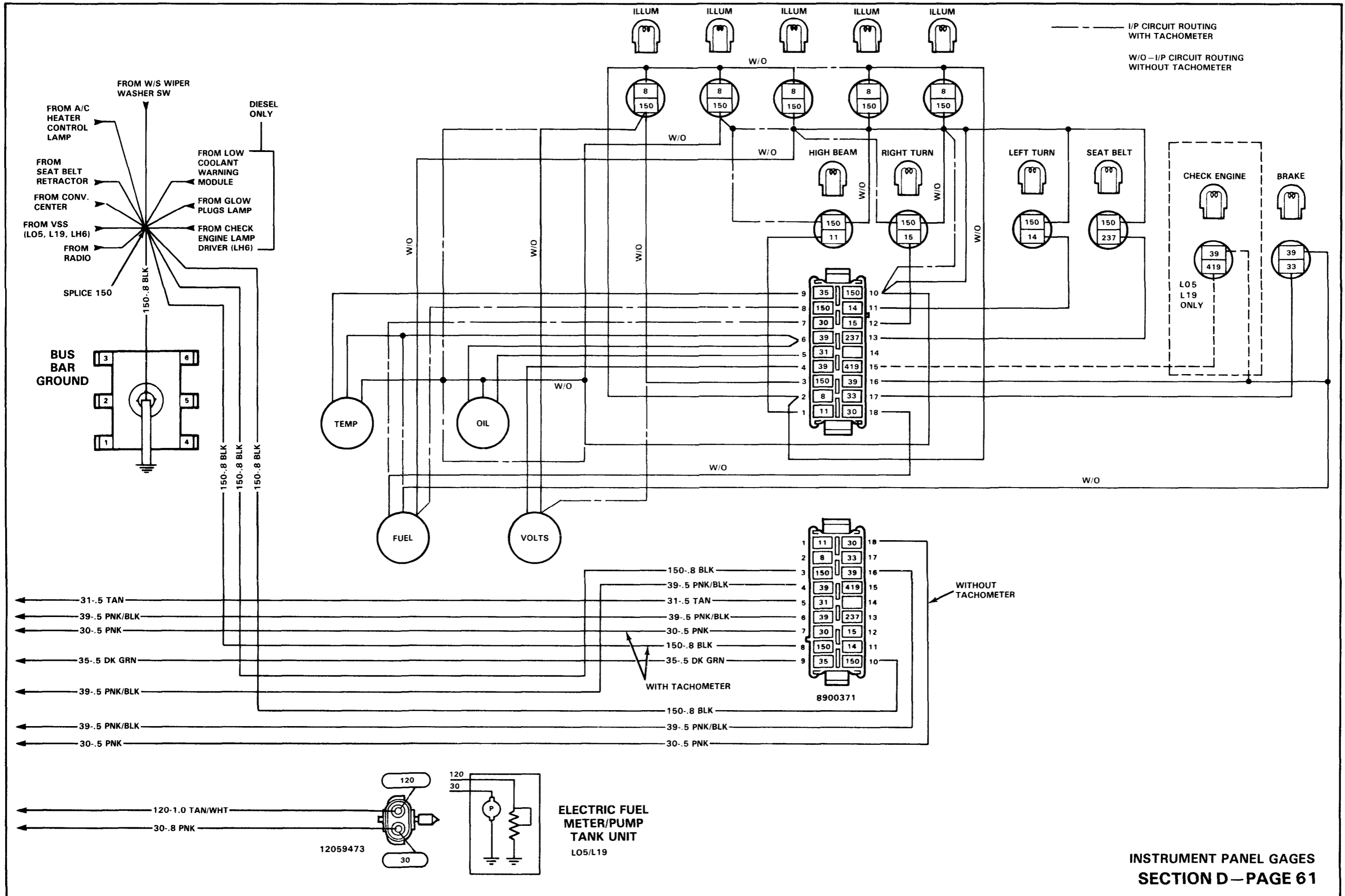

INDICATOR LAMPS

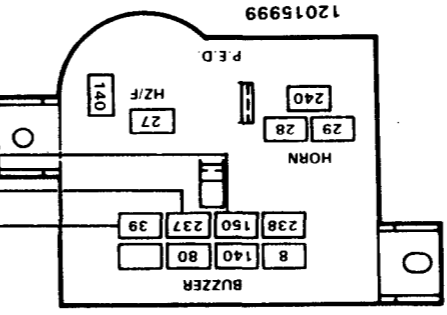
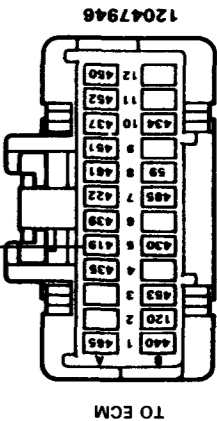
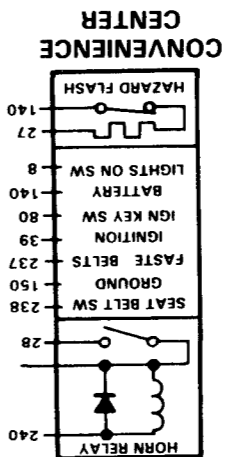
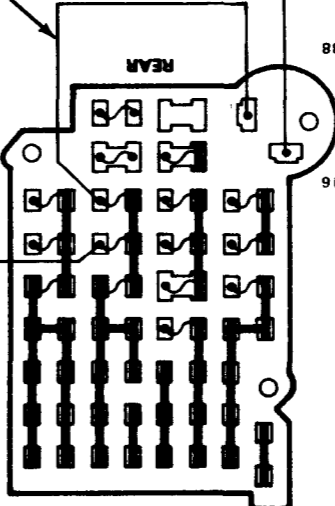
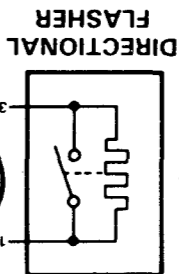
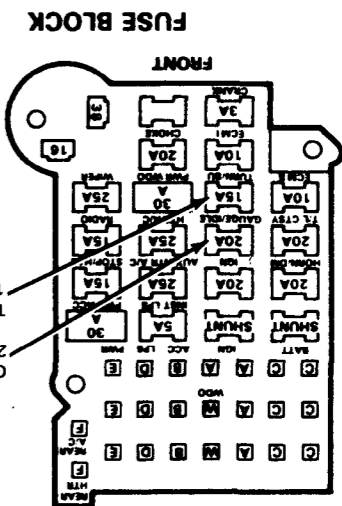
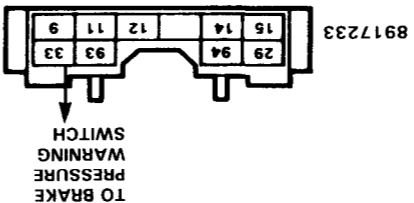
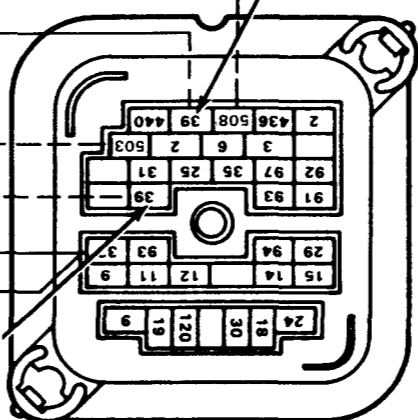
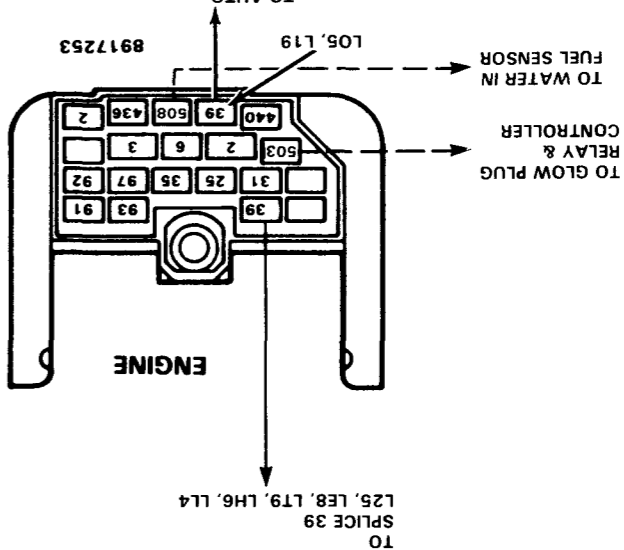

LOW COOLANT SWITCHING MODULE LH6, LL4 DIESEL

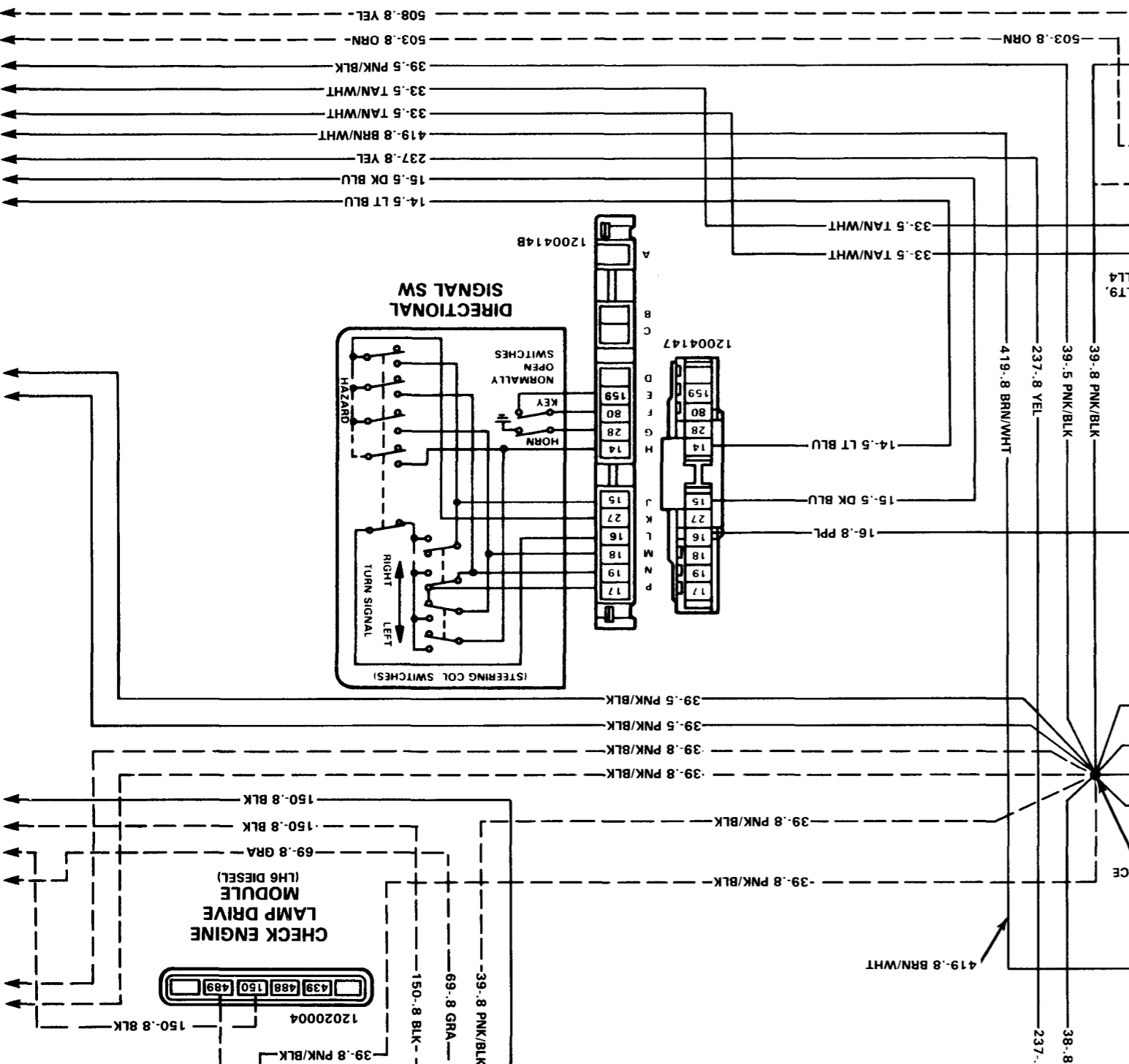
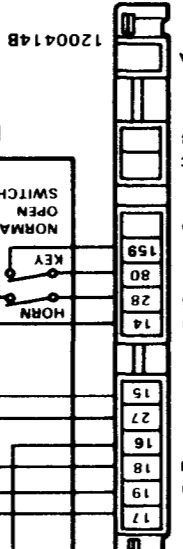
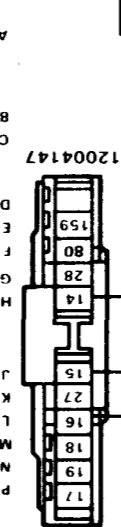
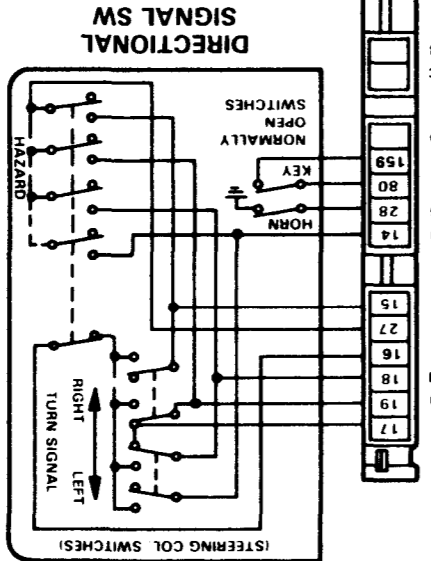
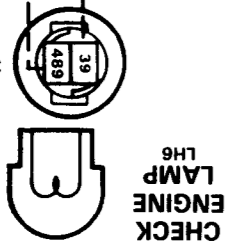
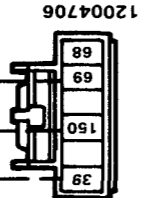
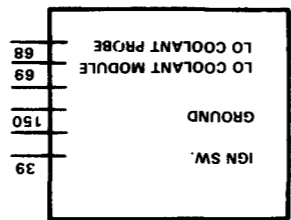

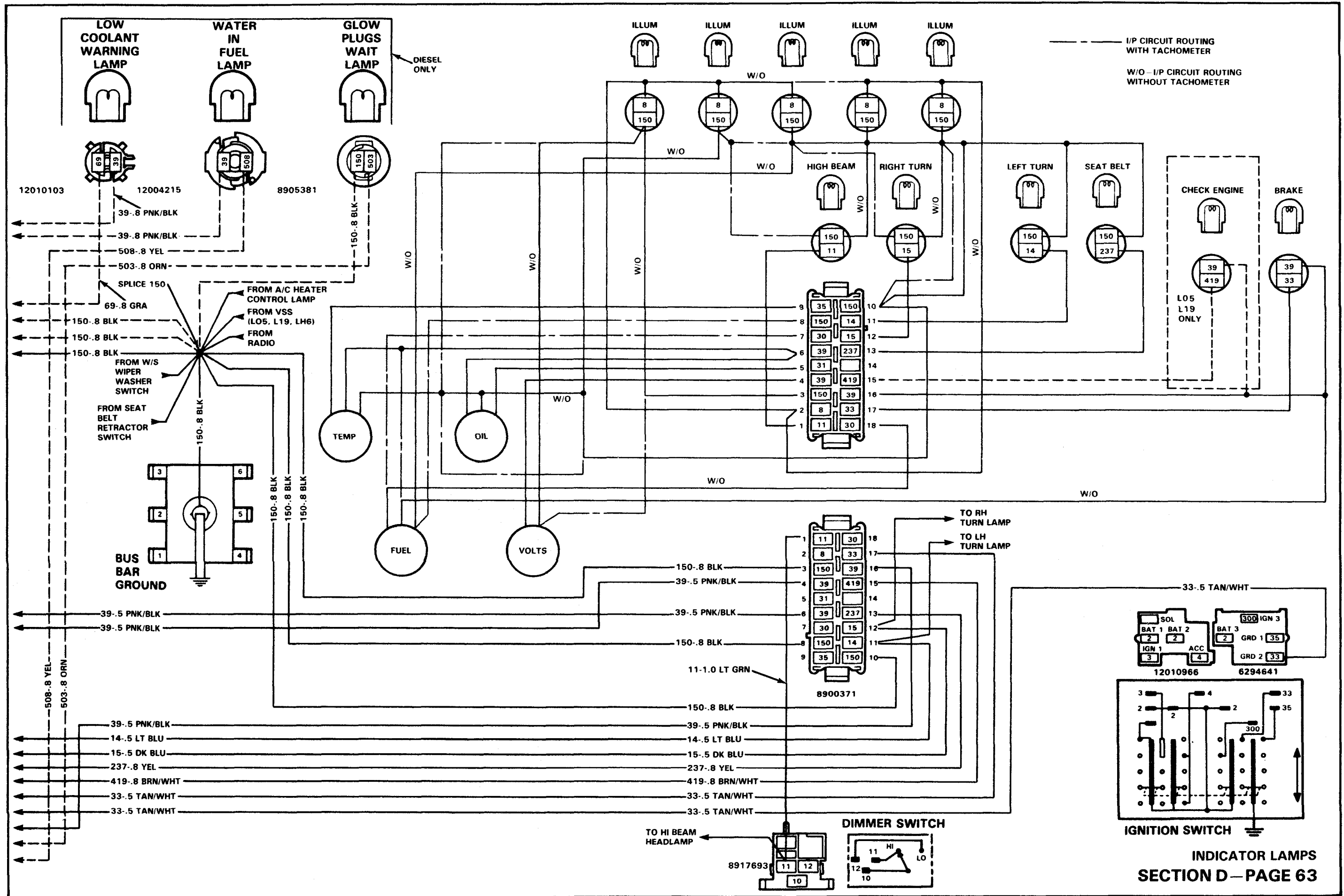

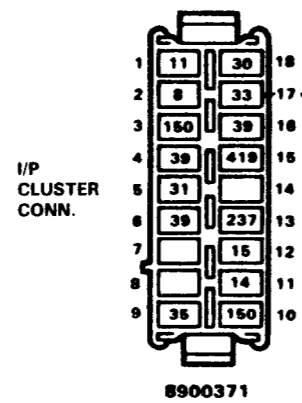

33-.5 TAN/WHT

33-.5 TAN/WHT

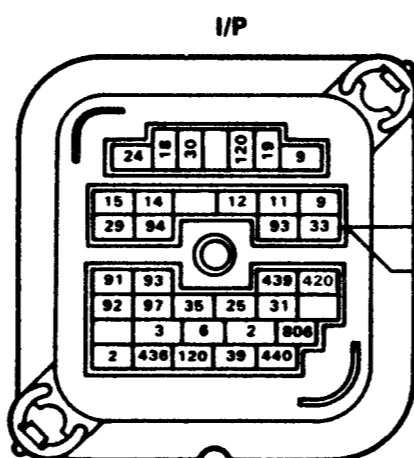

33-.5 TAN/WHT

33-.5 TAN/WHT

33-.5 TAN/WHT

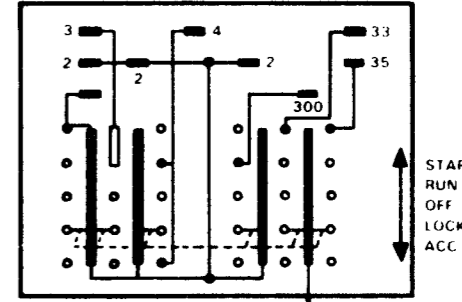
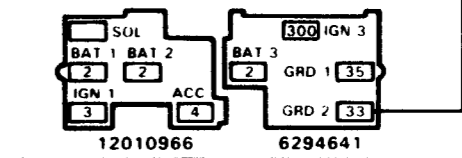

33-.5 TAN/WHT

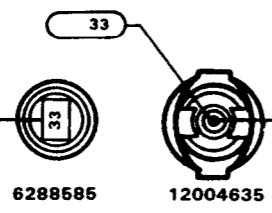

8917233

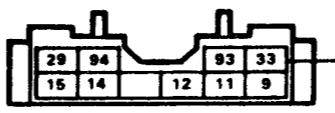

33-8 TAN/WHT

33-8 TAN/WHT

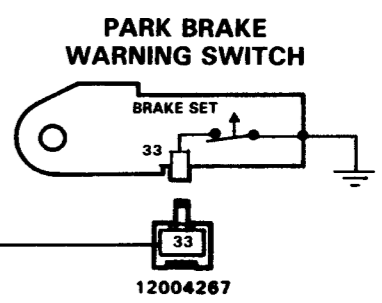
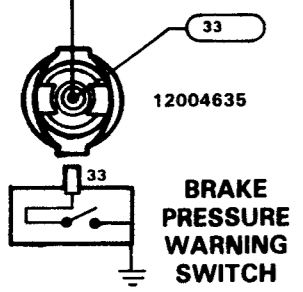

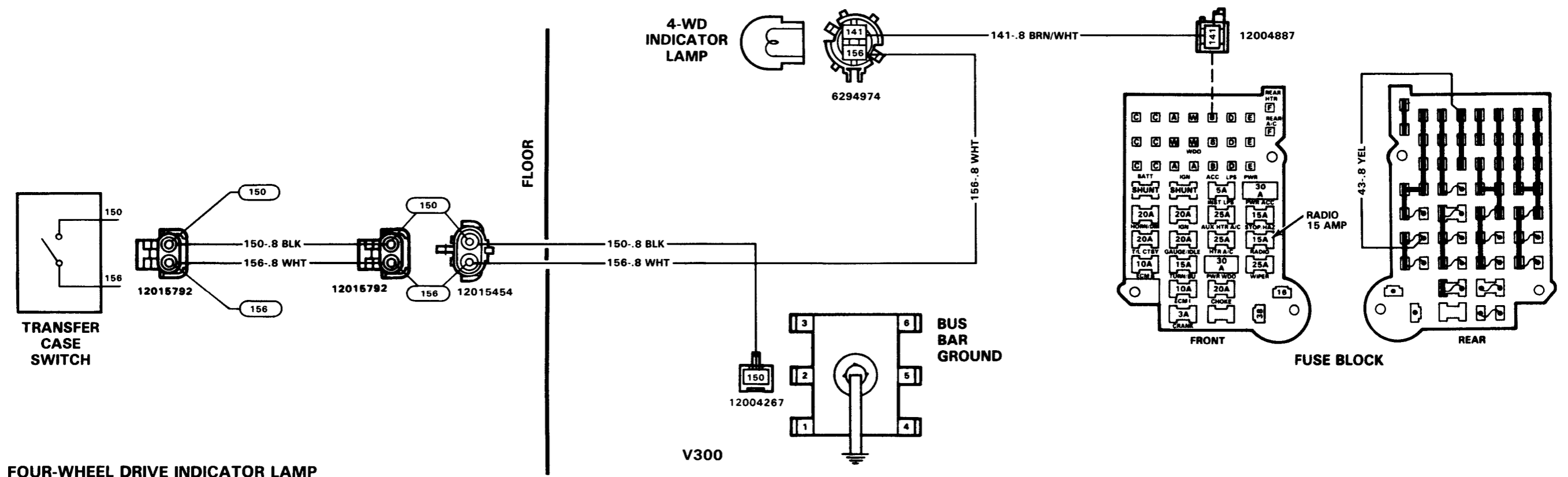
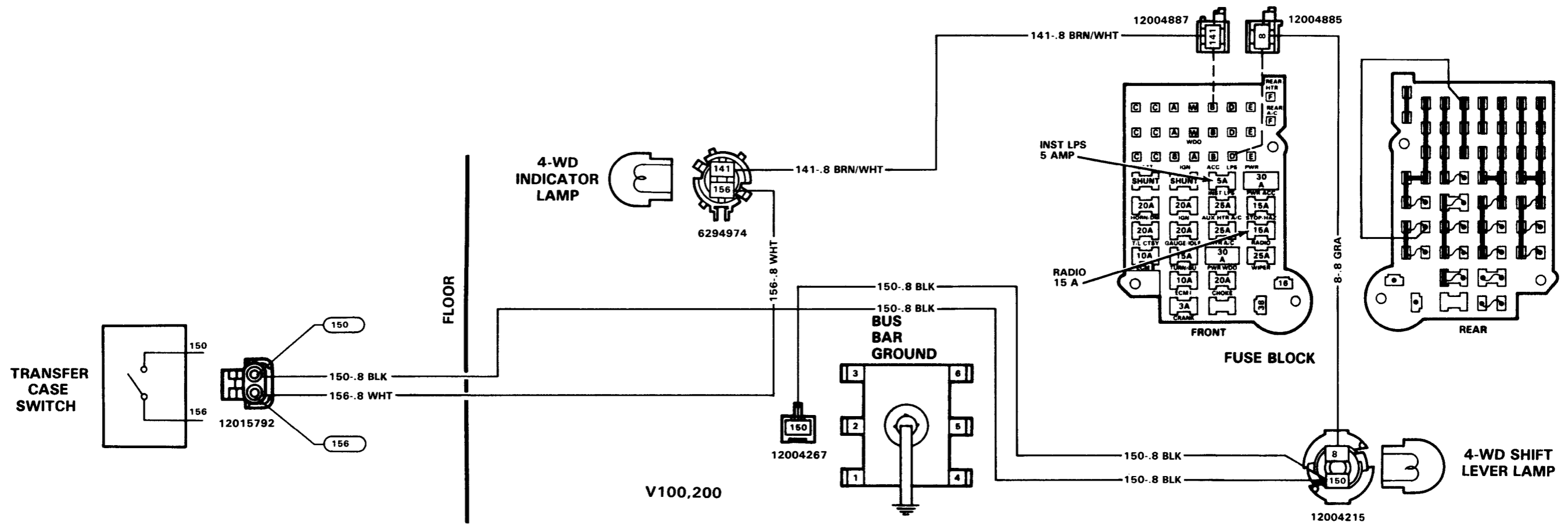

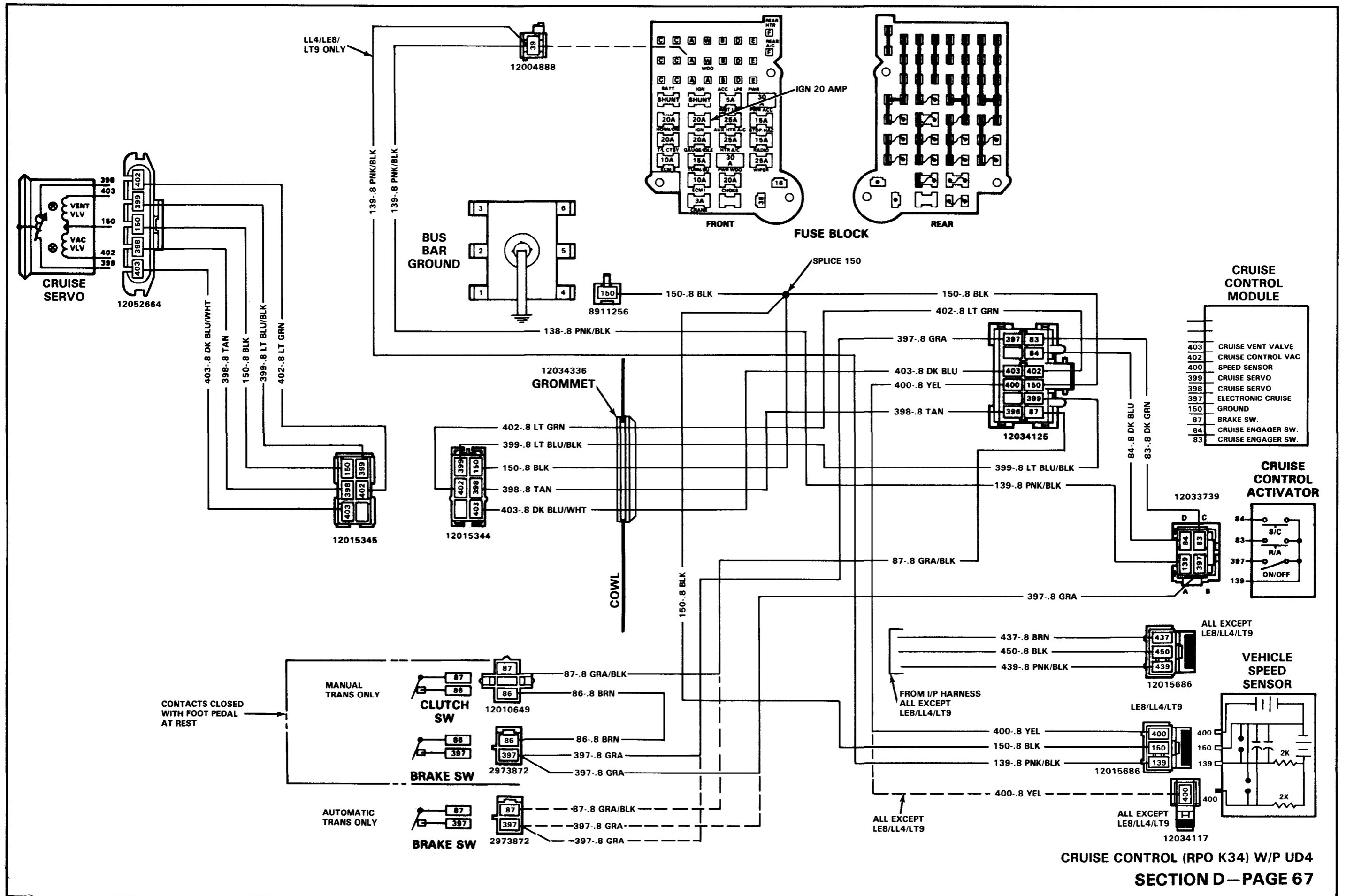

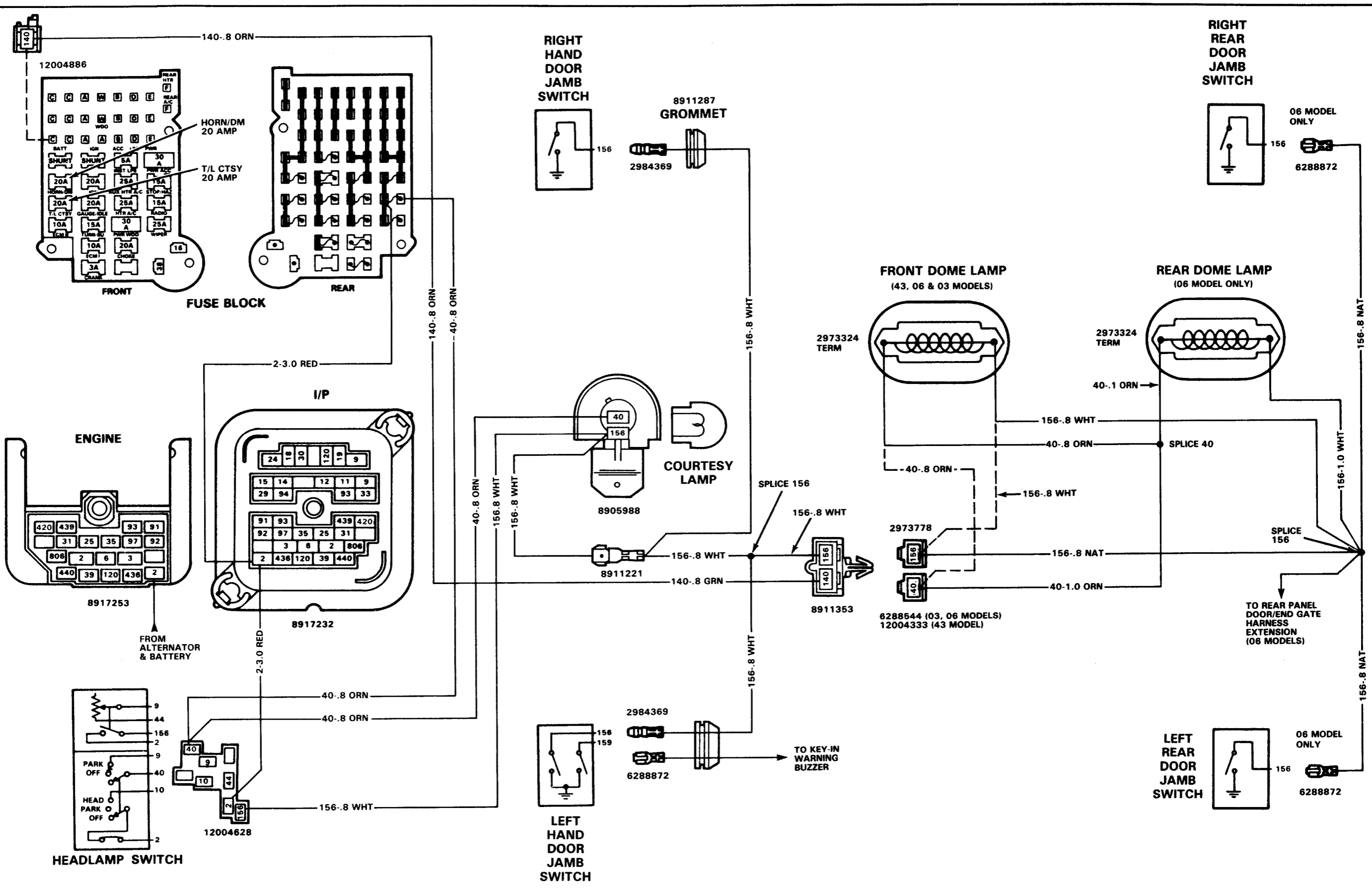

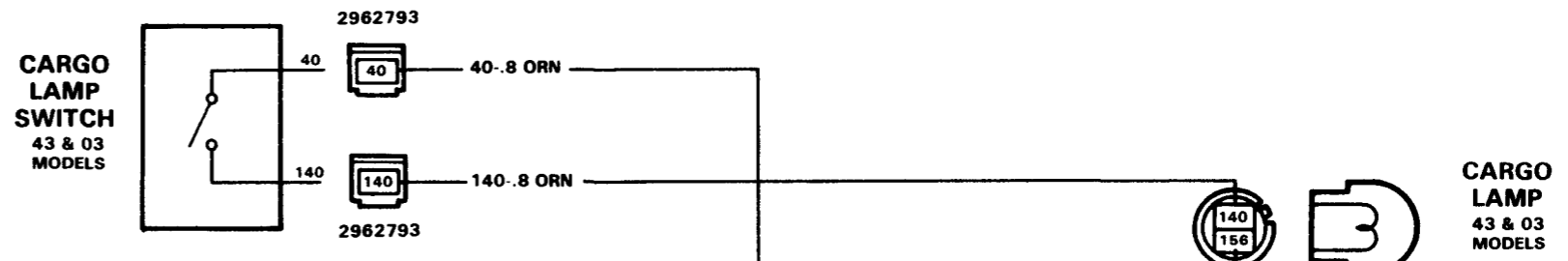

TO COURTESY LAMP & FRONT DOOR JAMB SWITCHES SEE DOME LAMPS

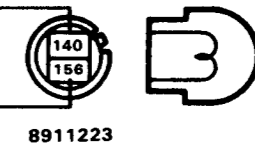
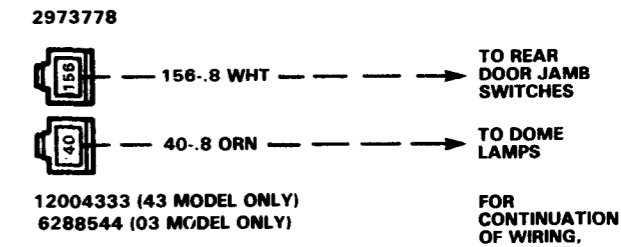
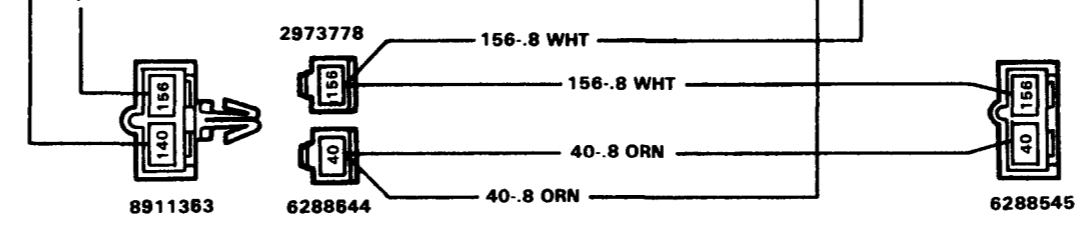
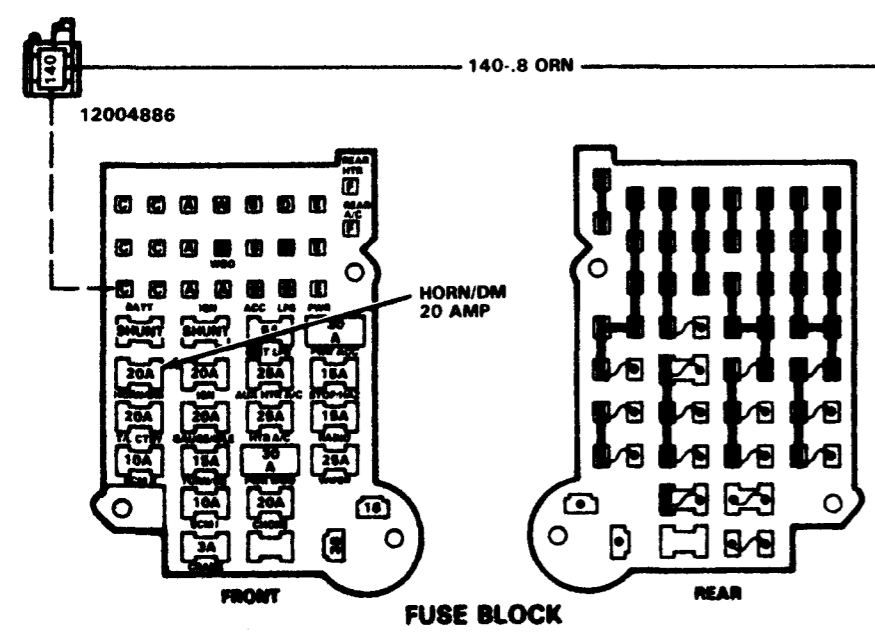

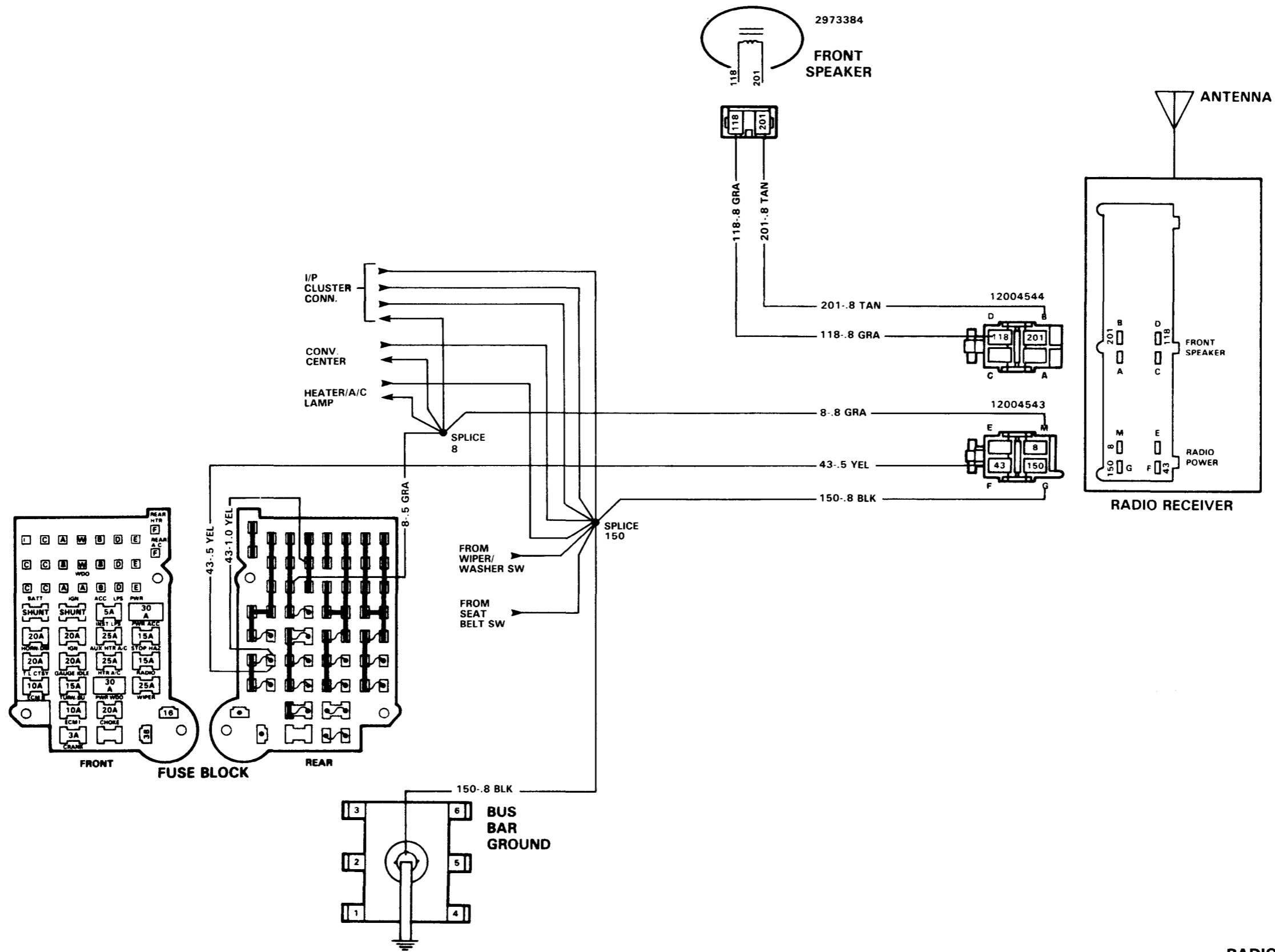

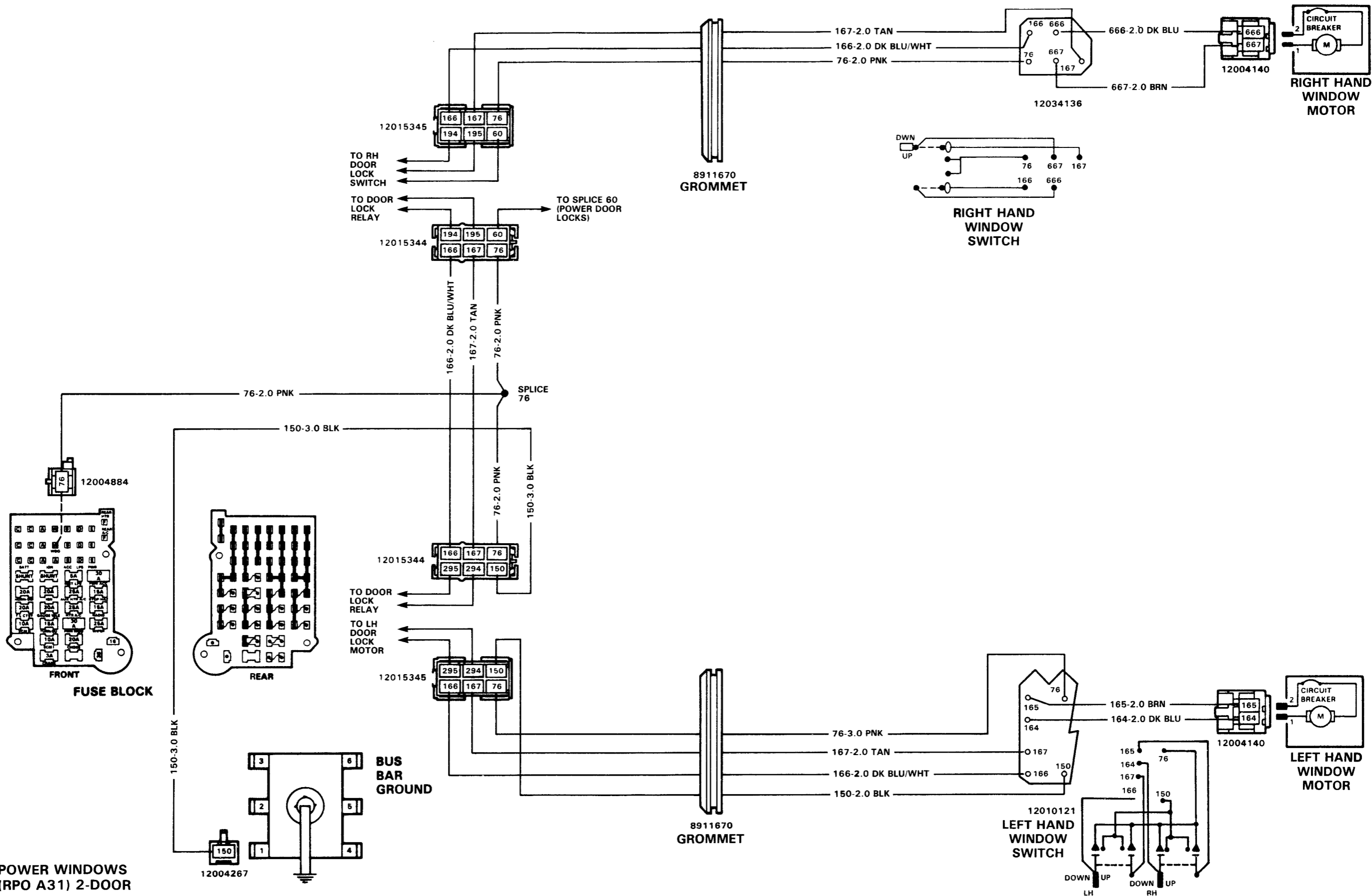

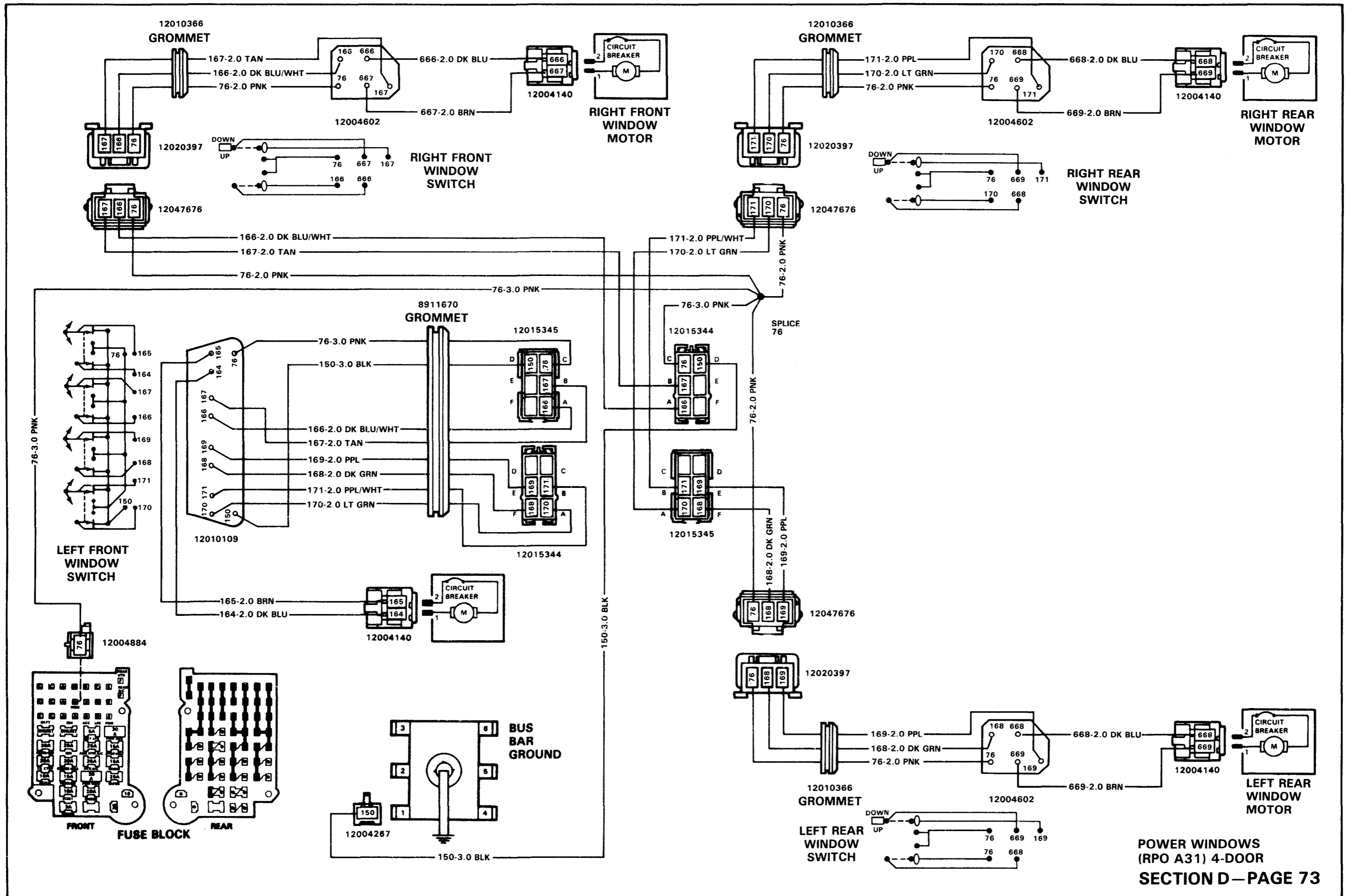

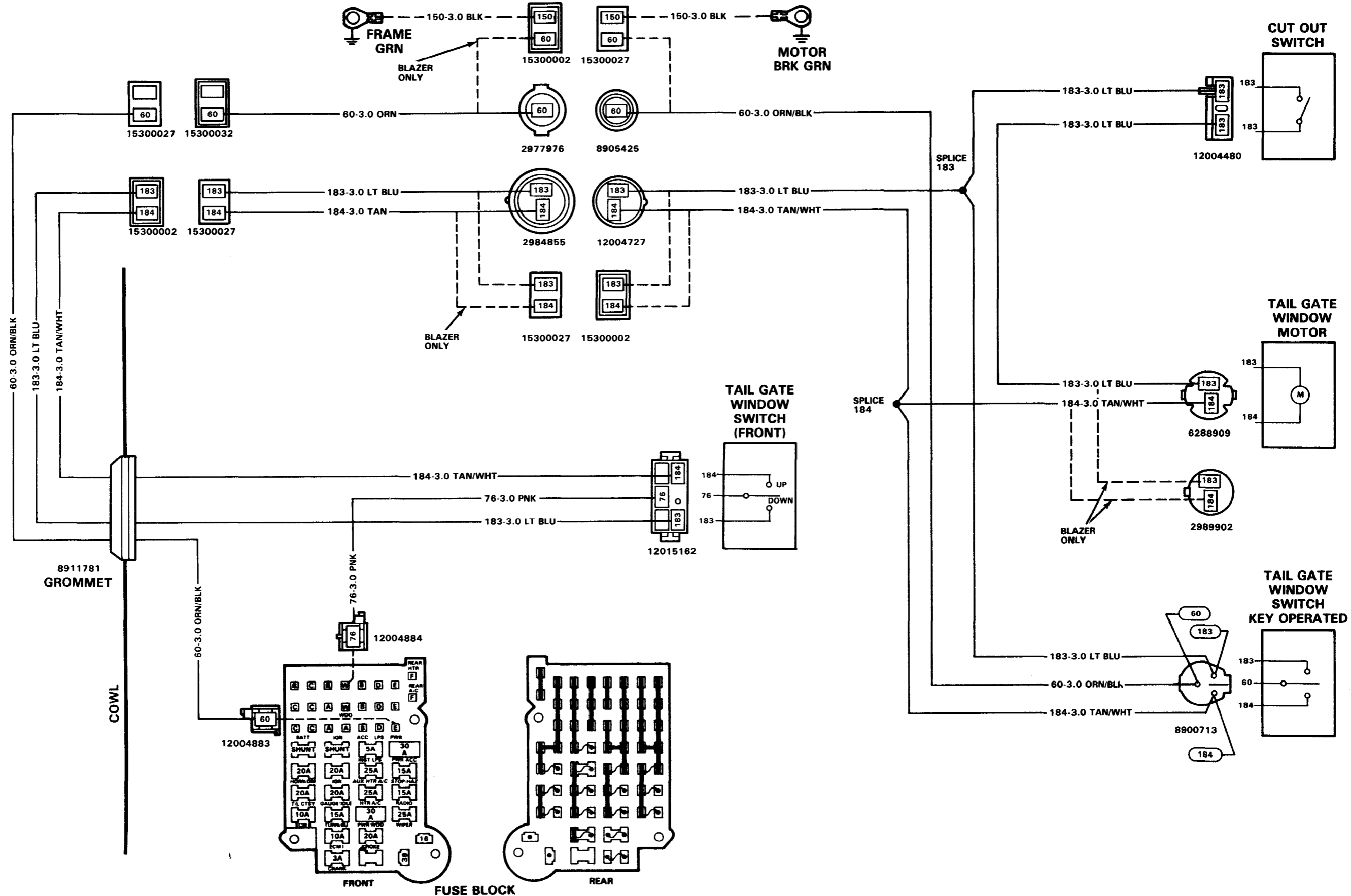

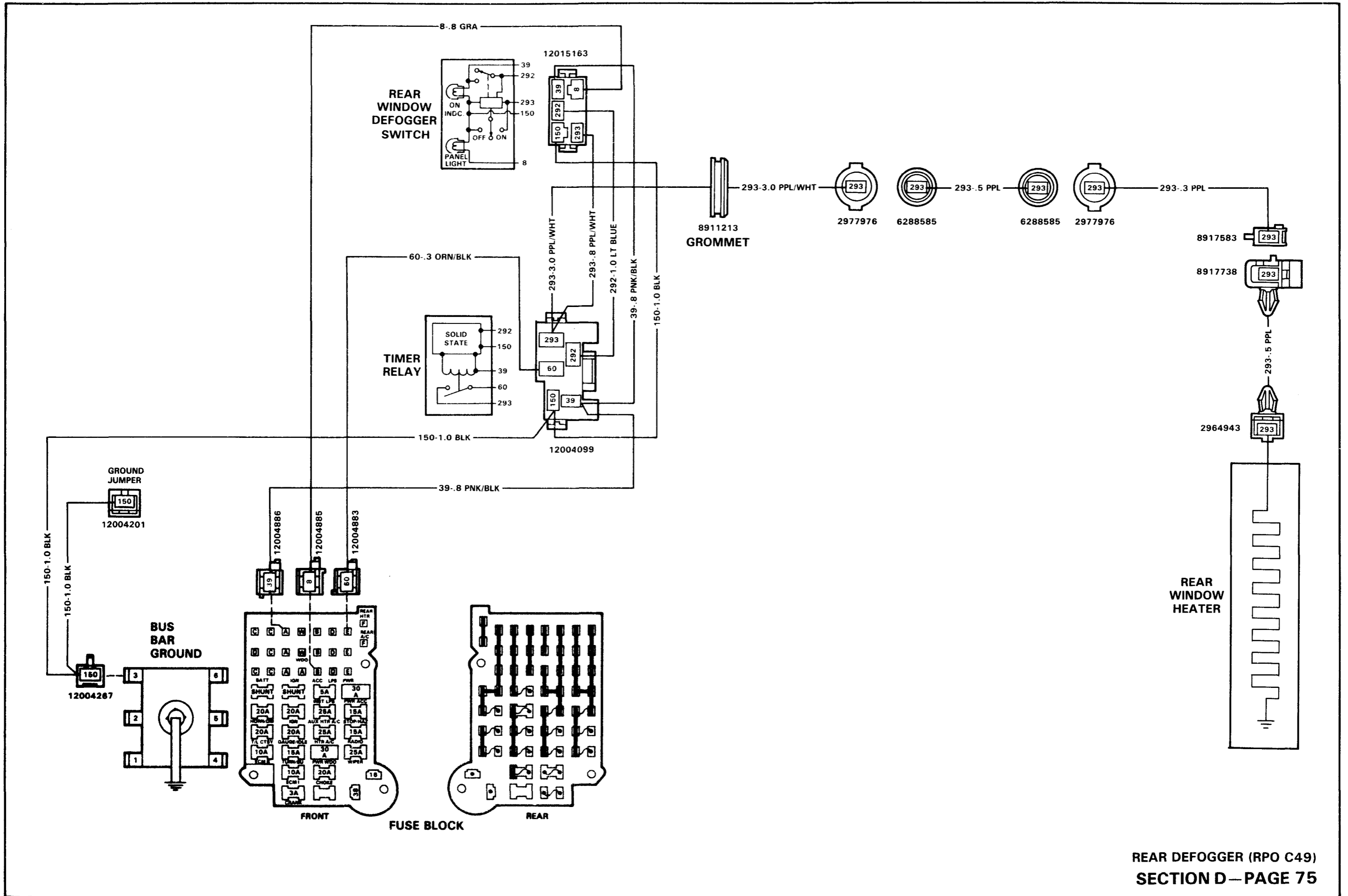

DOOR LOCK RELAY

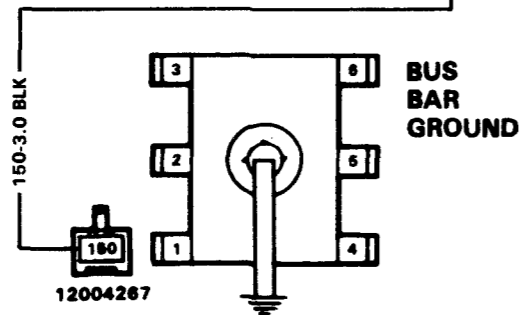
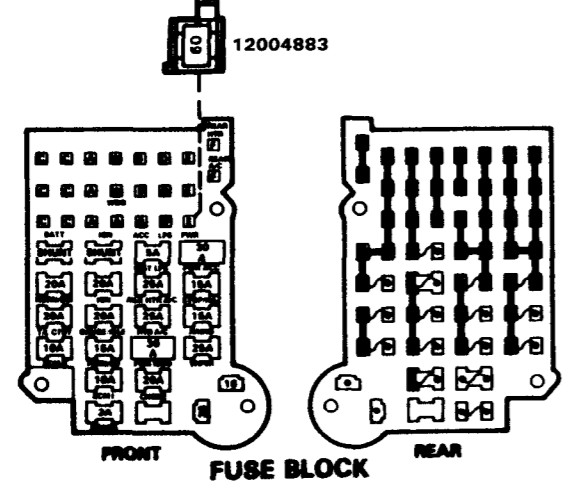
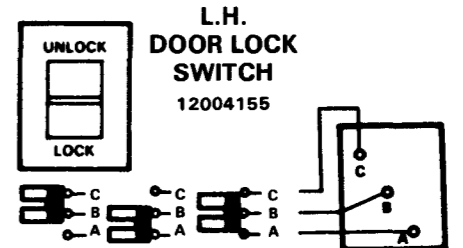
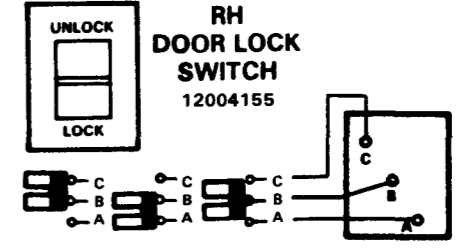
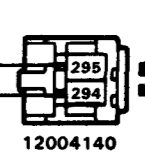
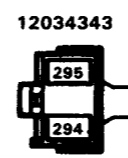
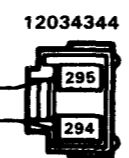
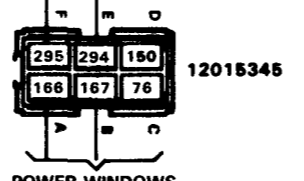
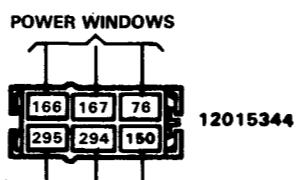
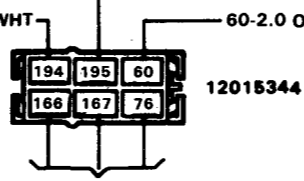
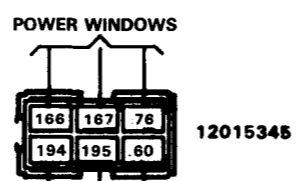
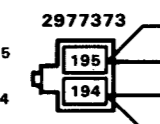
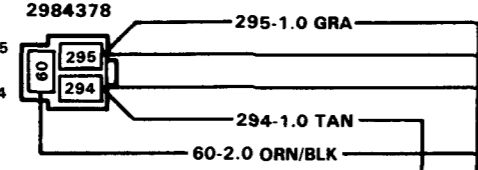
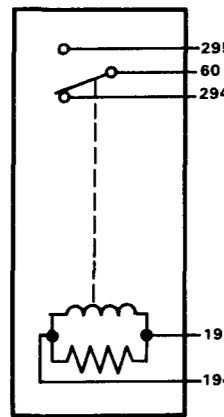

8911670
GROMMET

SPLICE
60

8911670
GROMMET

**RIGHT HAND
DOOR LOCK
MOTOR**

**LEFT HAND
DOOR LOCK
MOTOR**

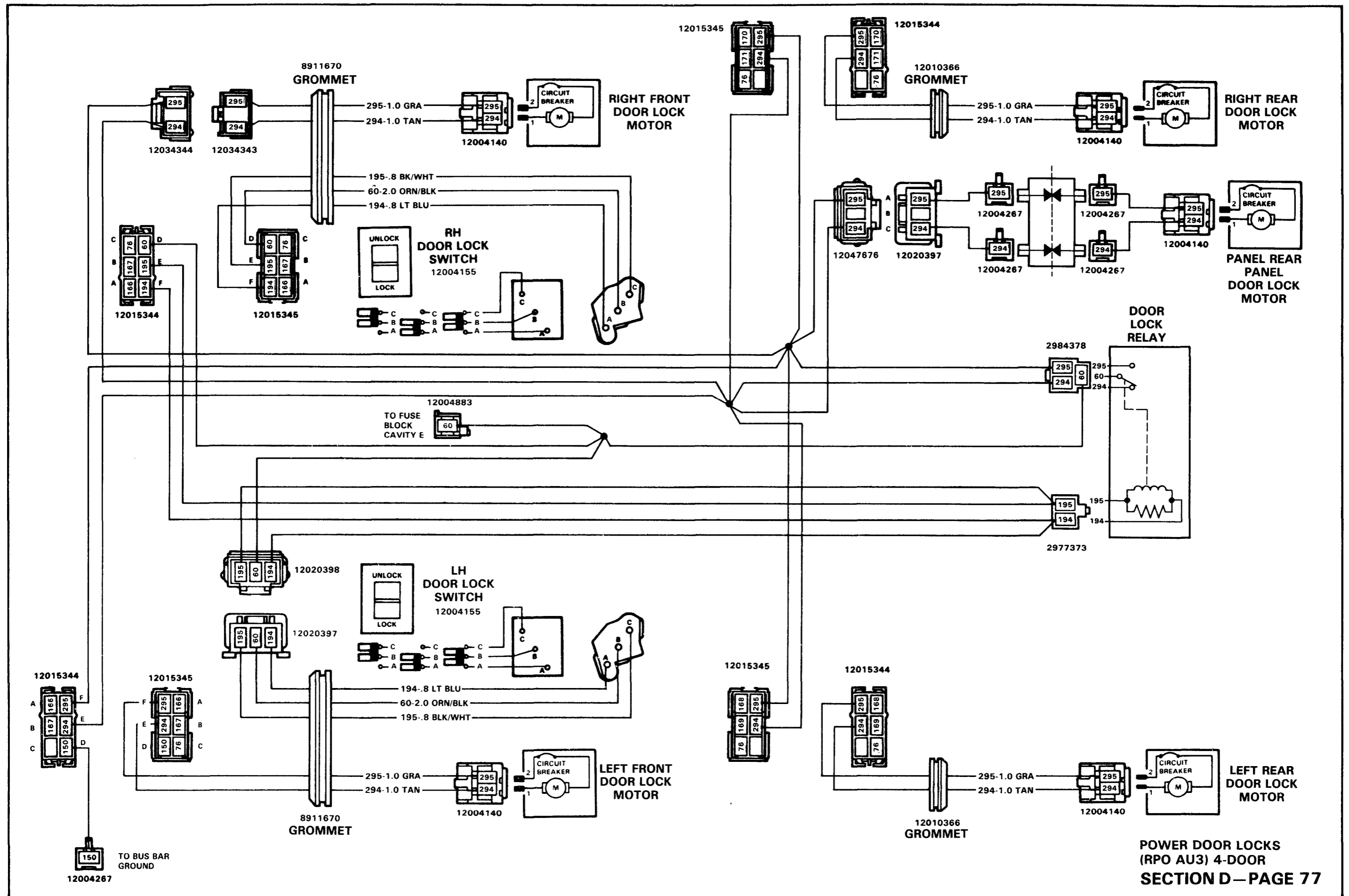

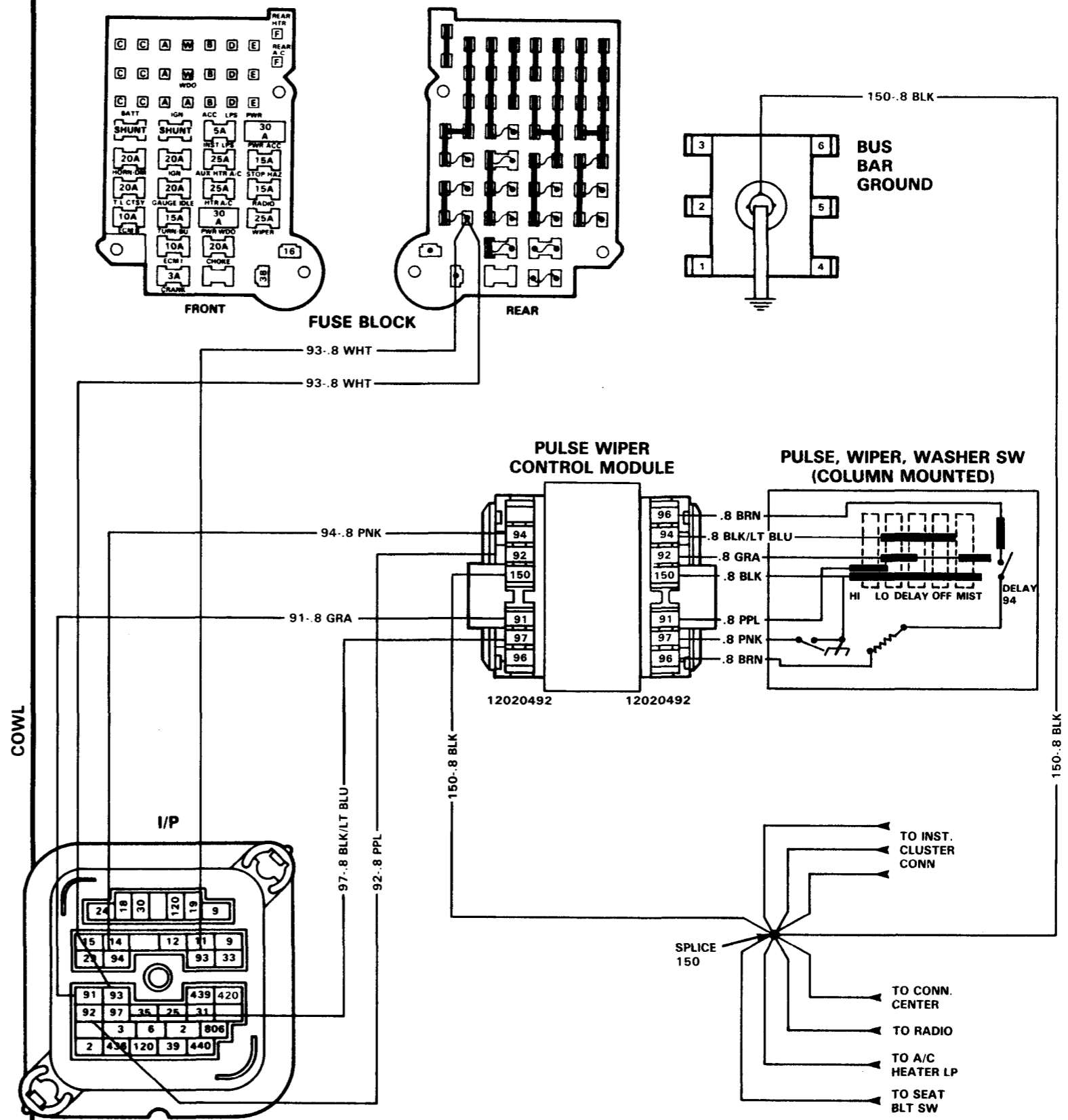
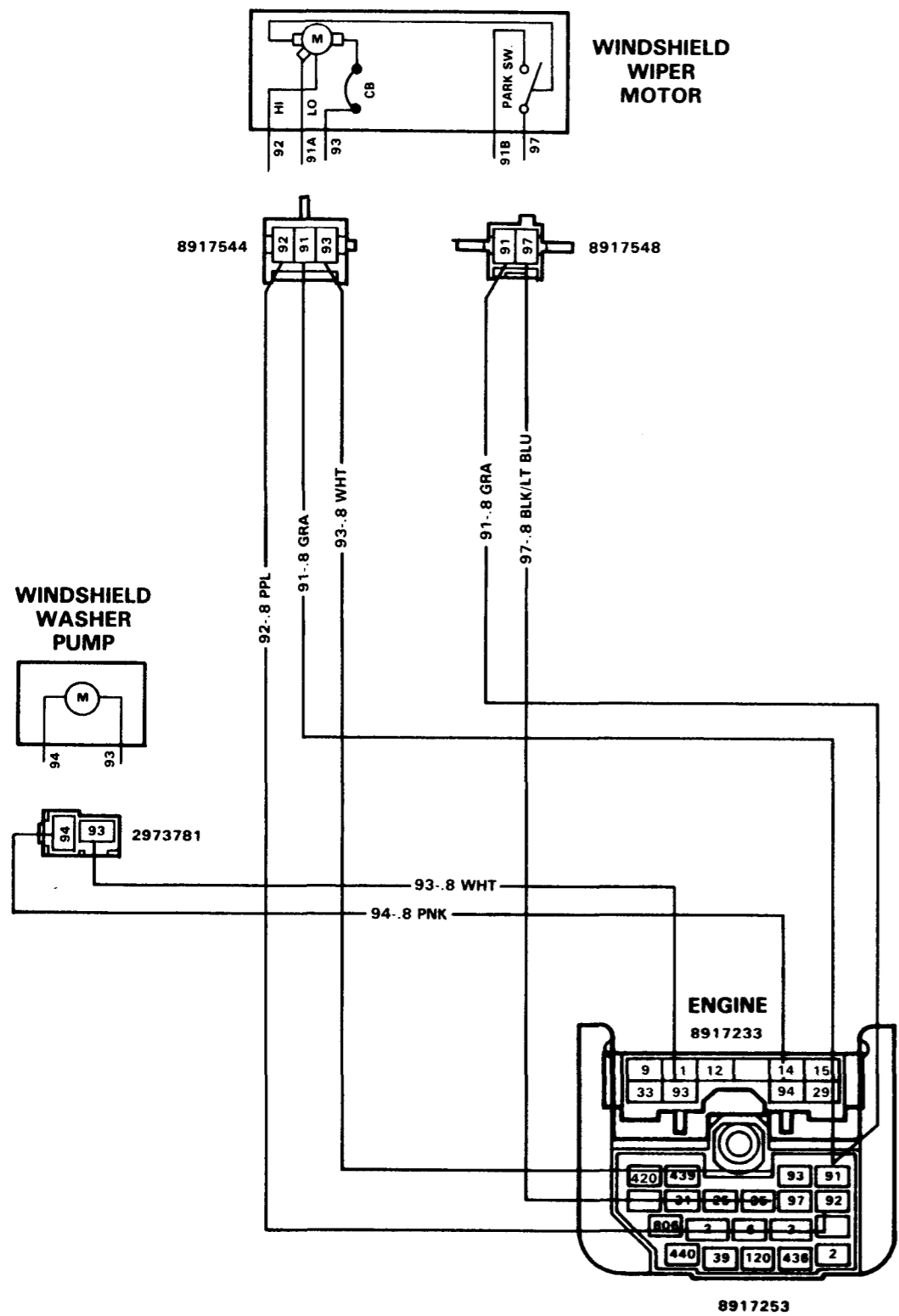

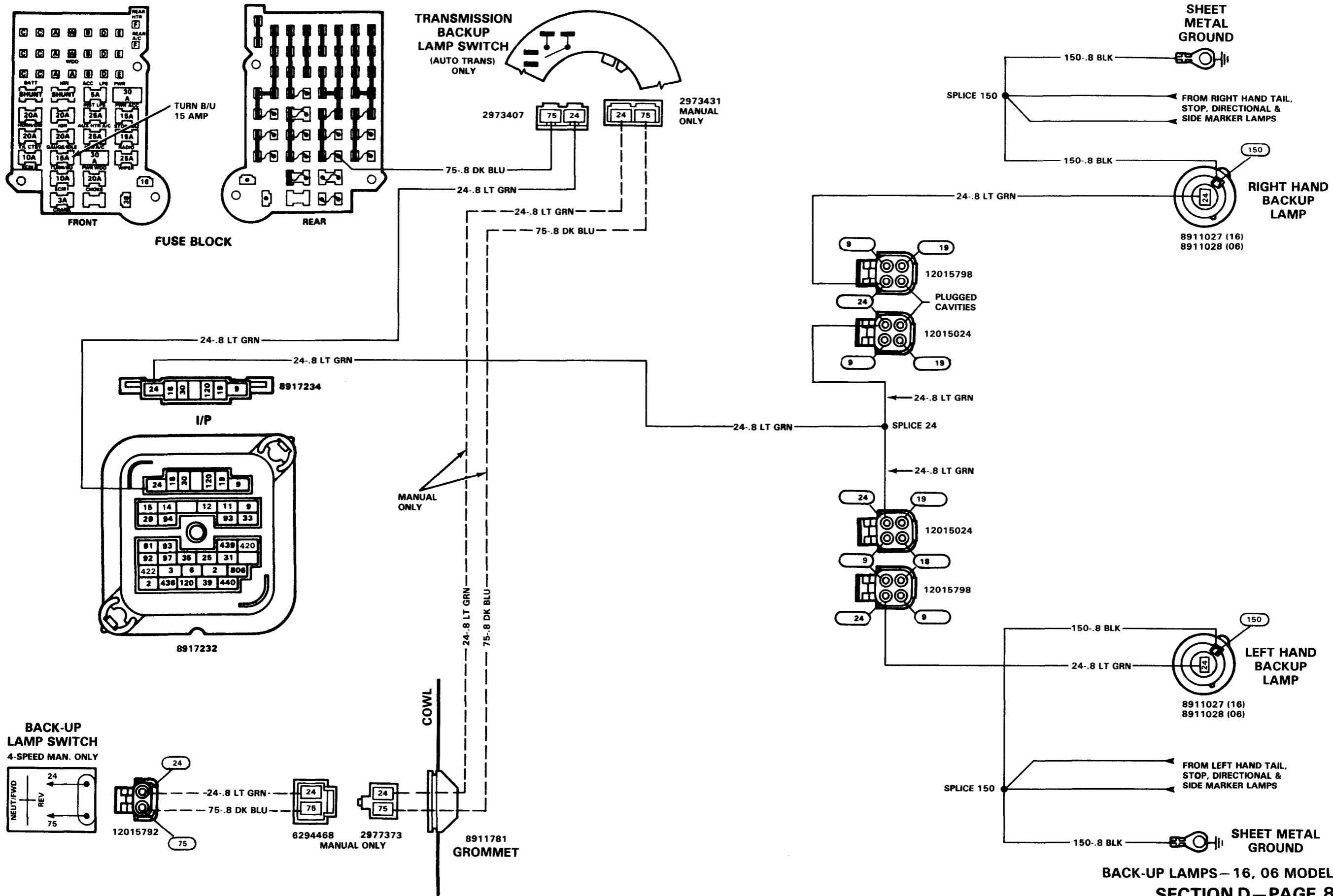

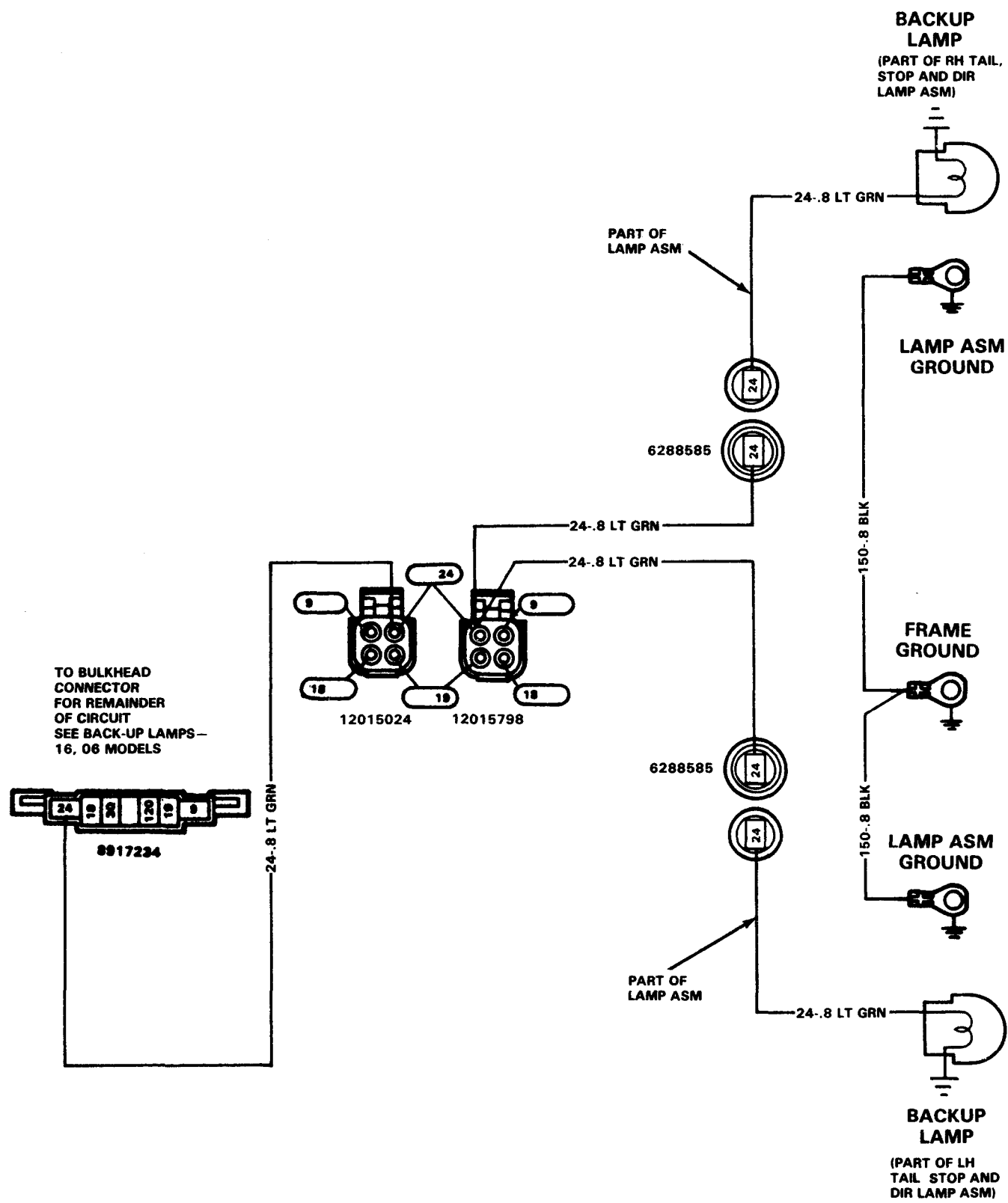

03 & 43 MODELS W/O RPO E62, E63

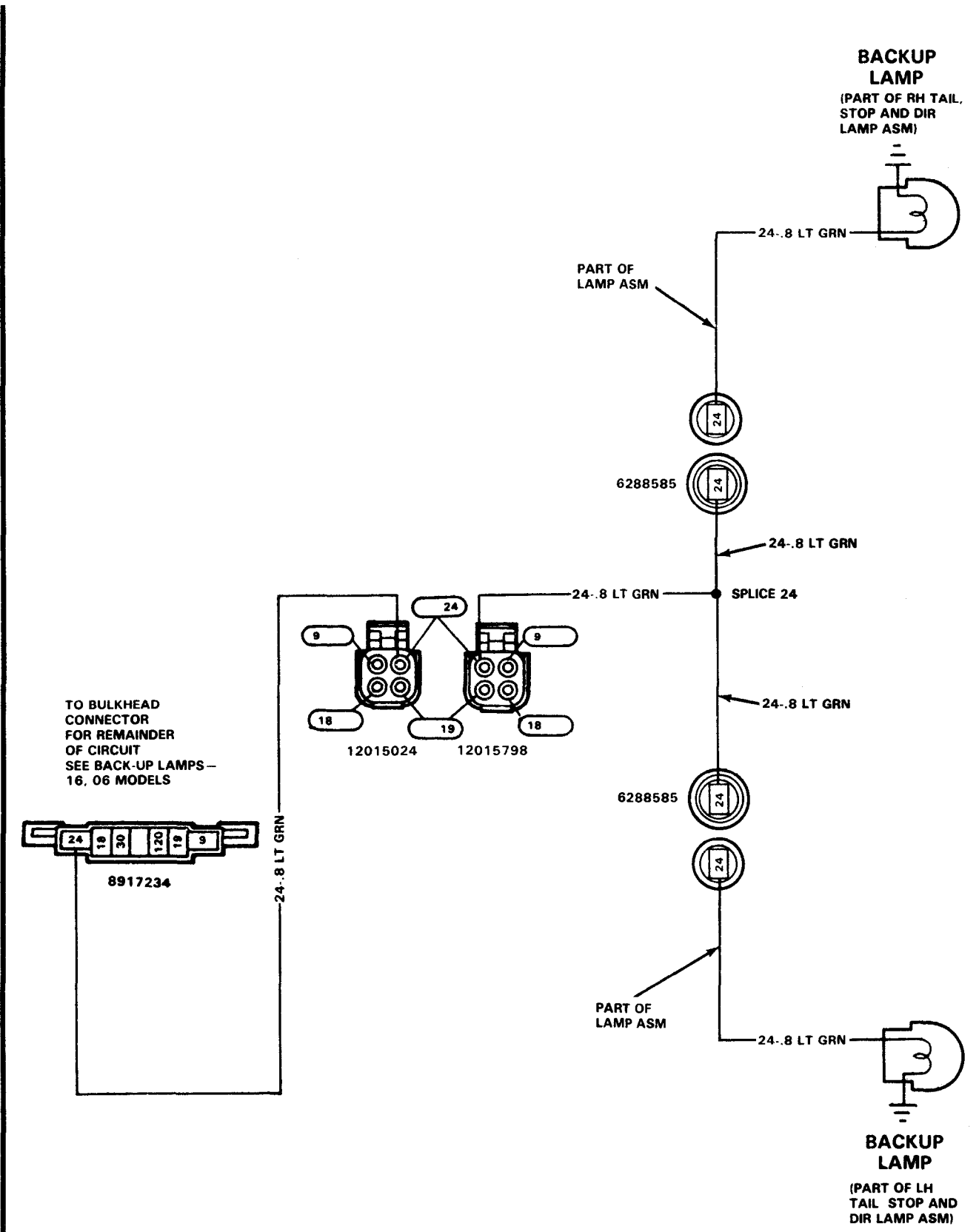

STEPSIDE PICKUP . RPO E62

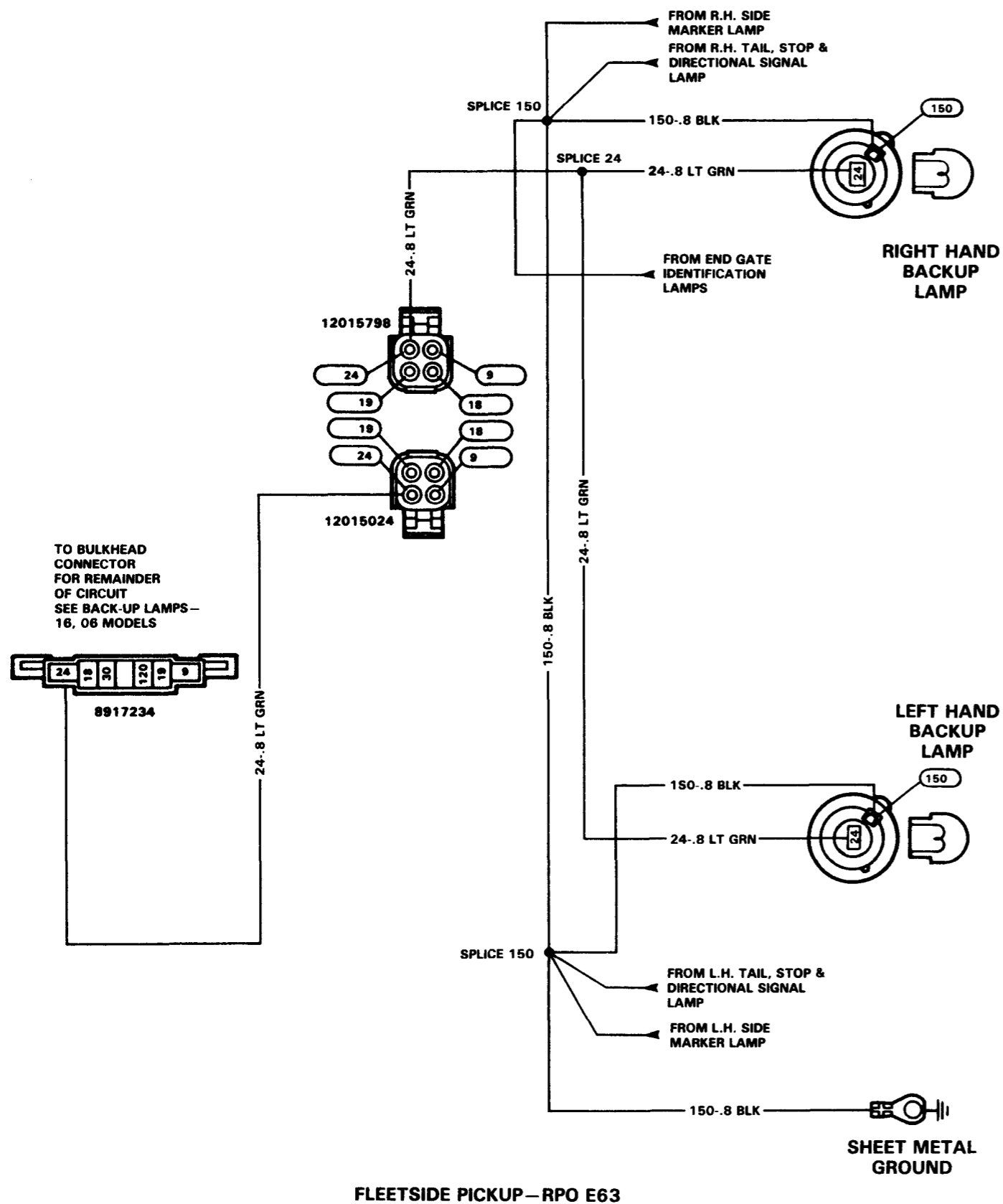

FLEETSIDE PICKUP - RPO E63

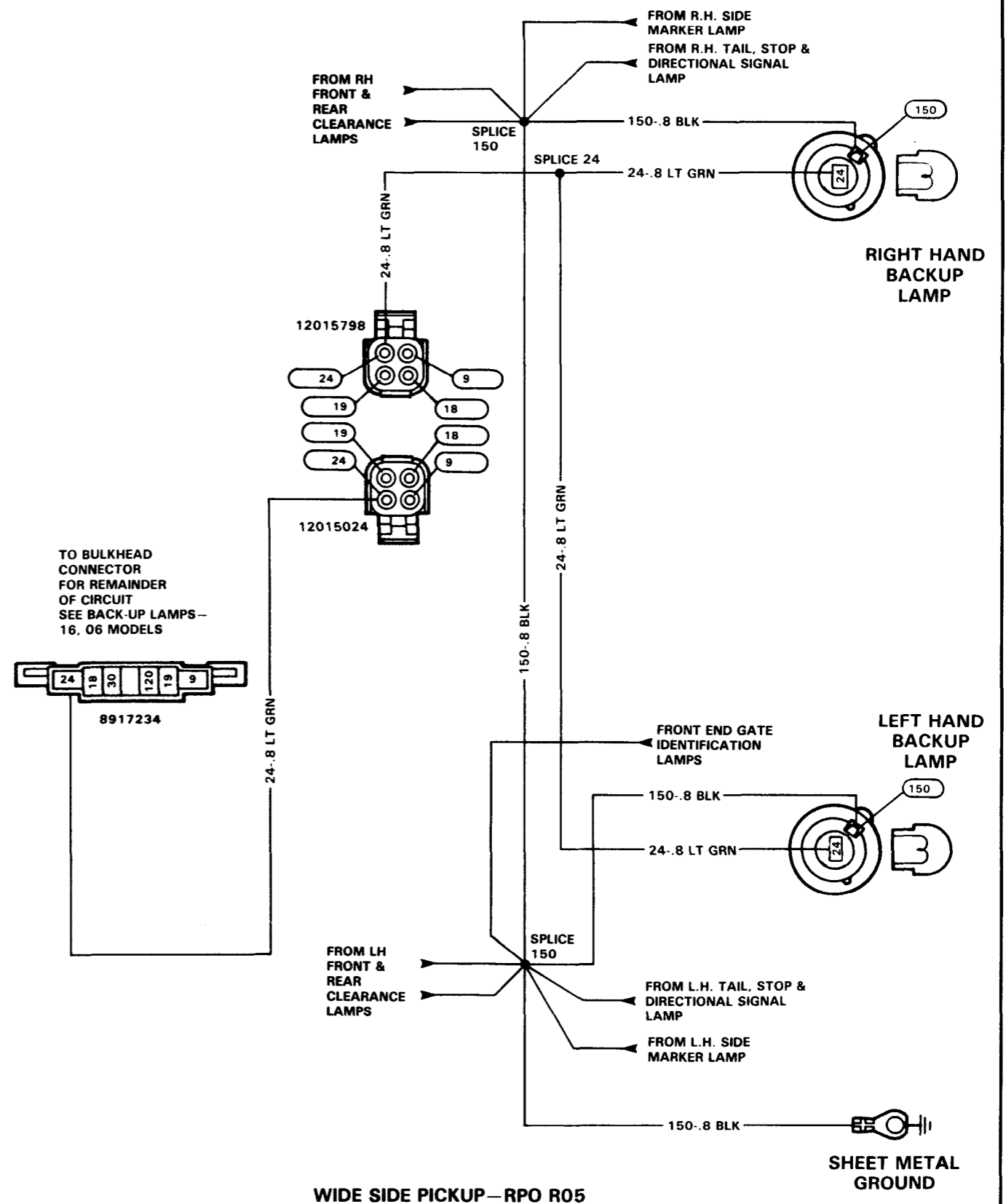

WIDE SIDE PICKUP - RPO R05

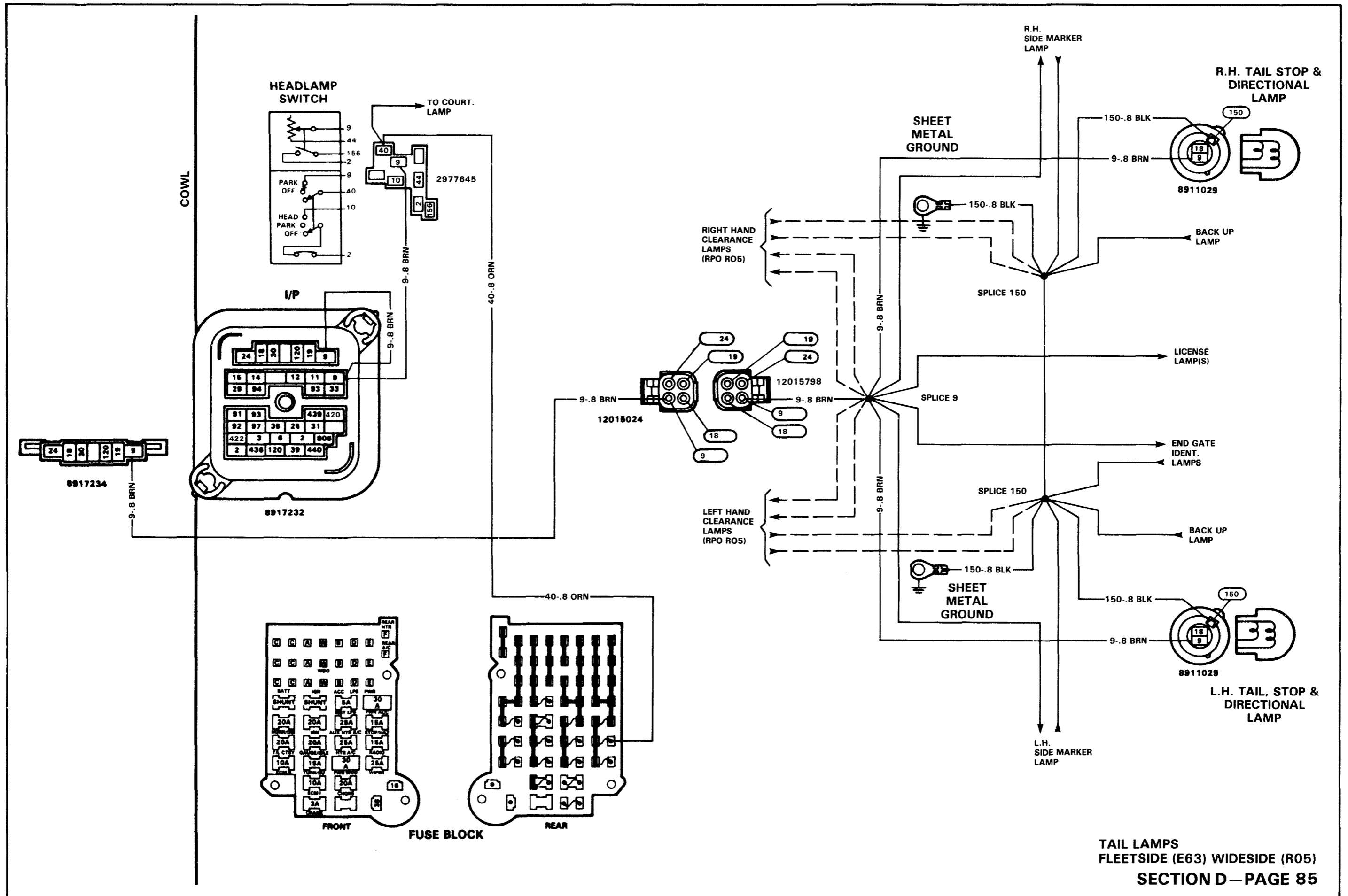

RIGHT HAND

SIDE MARKER LAMP

BACK UP LAMP

TAIL, STOP & DIR LAMP

LEFT HAND

TAIL, STOP & DIR LAMP

BACK UP LAMP

SIDE MARKER LAMP

COWL

HEADLAMP SWITCH

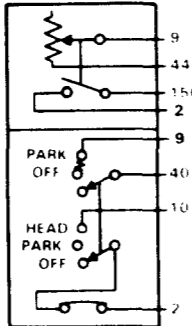

TO COURT. LAMP

2977645

I/P

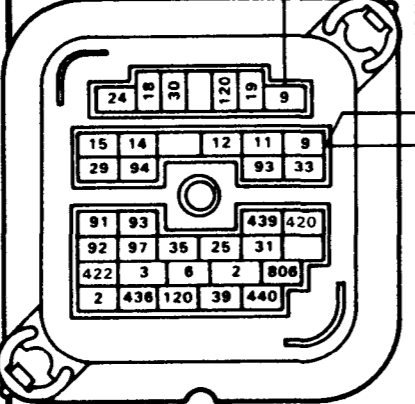

8917232

8917234



9-8 BRN

40-8 ORN

12015024

9-8 BRN

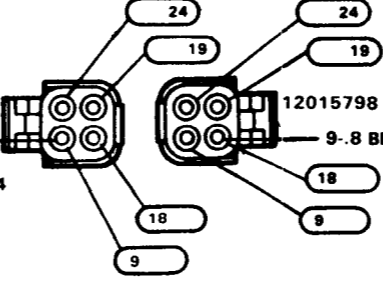

12015798

9-8 BRN

SPLICE 9

LICENSE LAMPS

6288424

6288424

40-8 ORN

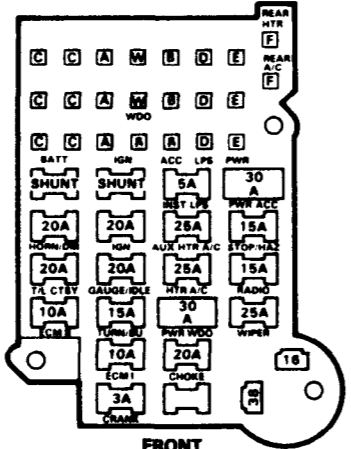

FRONT

FUSE BLOCK

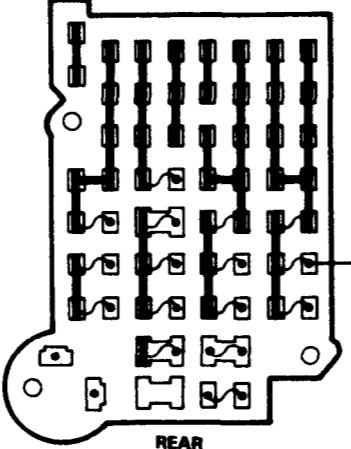

REAR

TAIL LAMPS
STEPSIDE PICKUP (E62)
SECTION D—PAGE 86

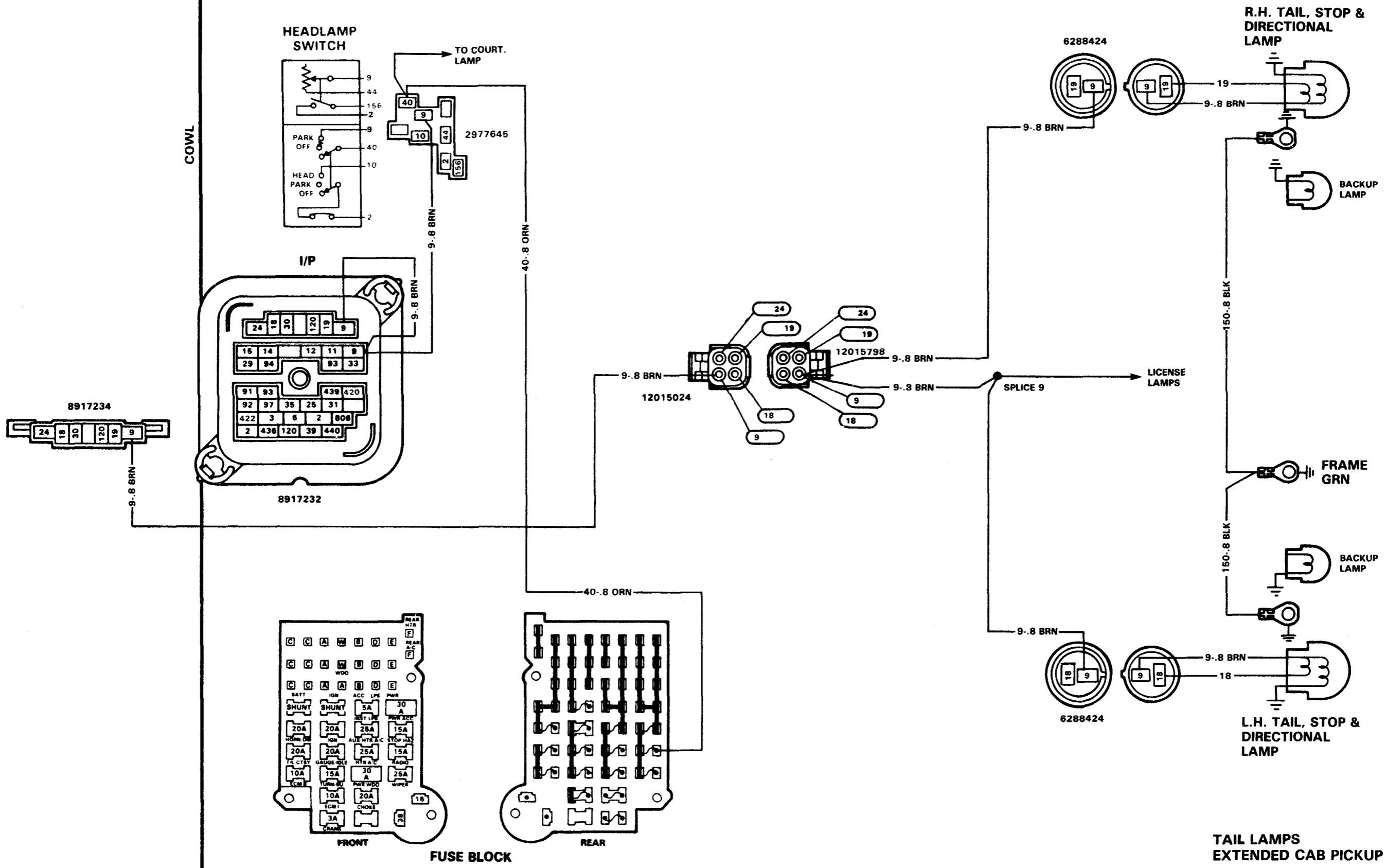

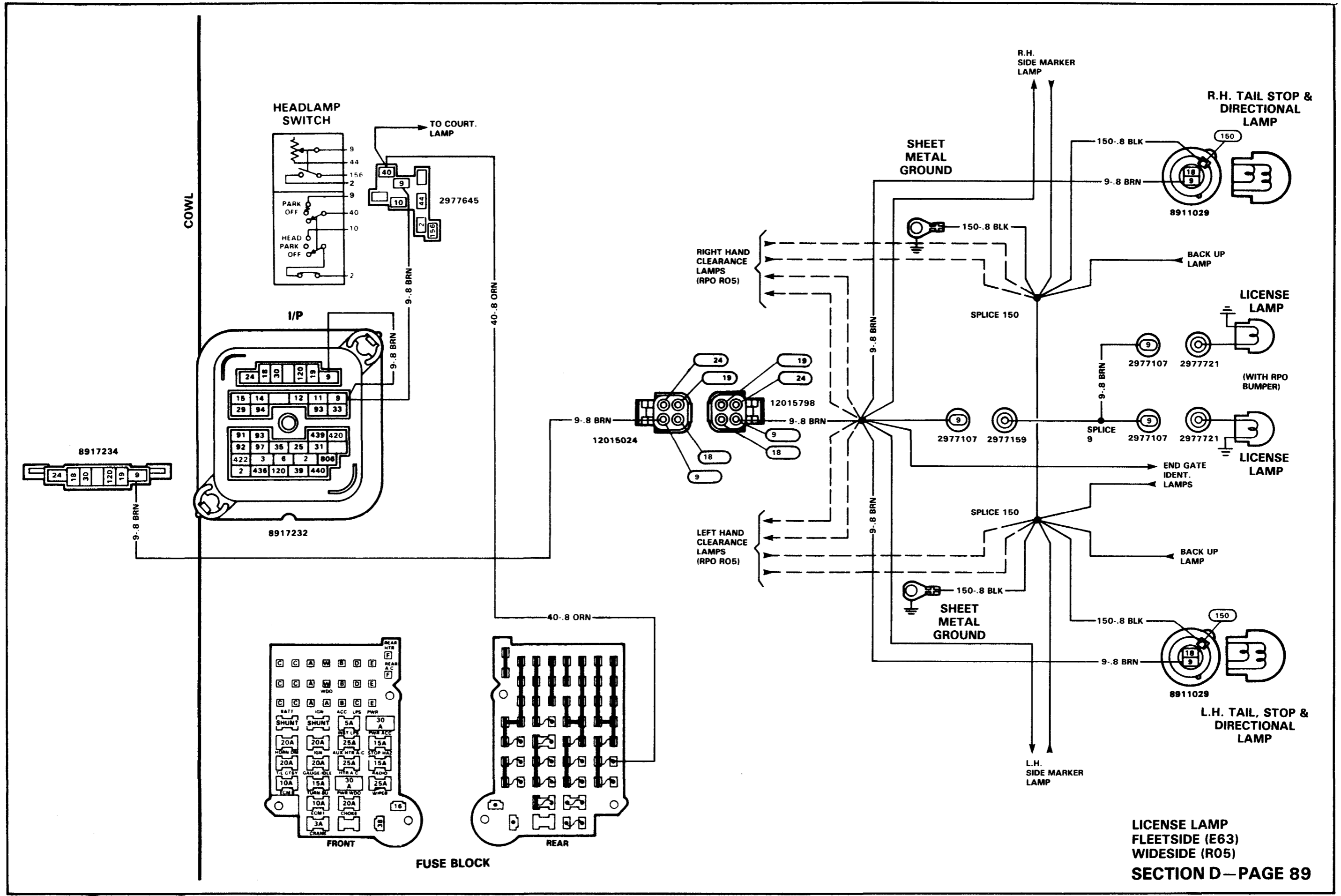

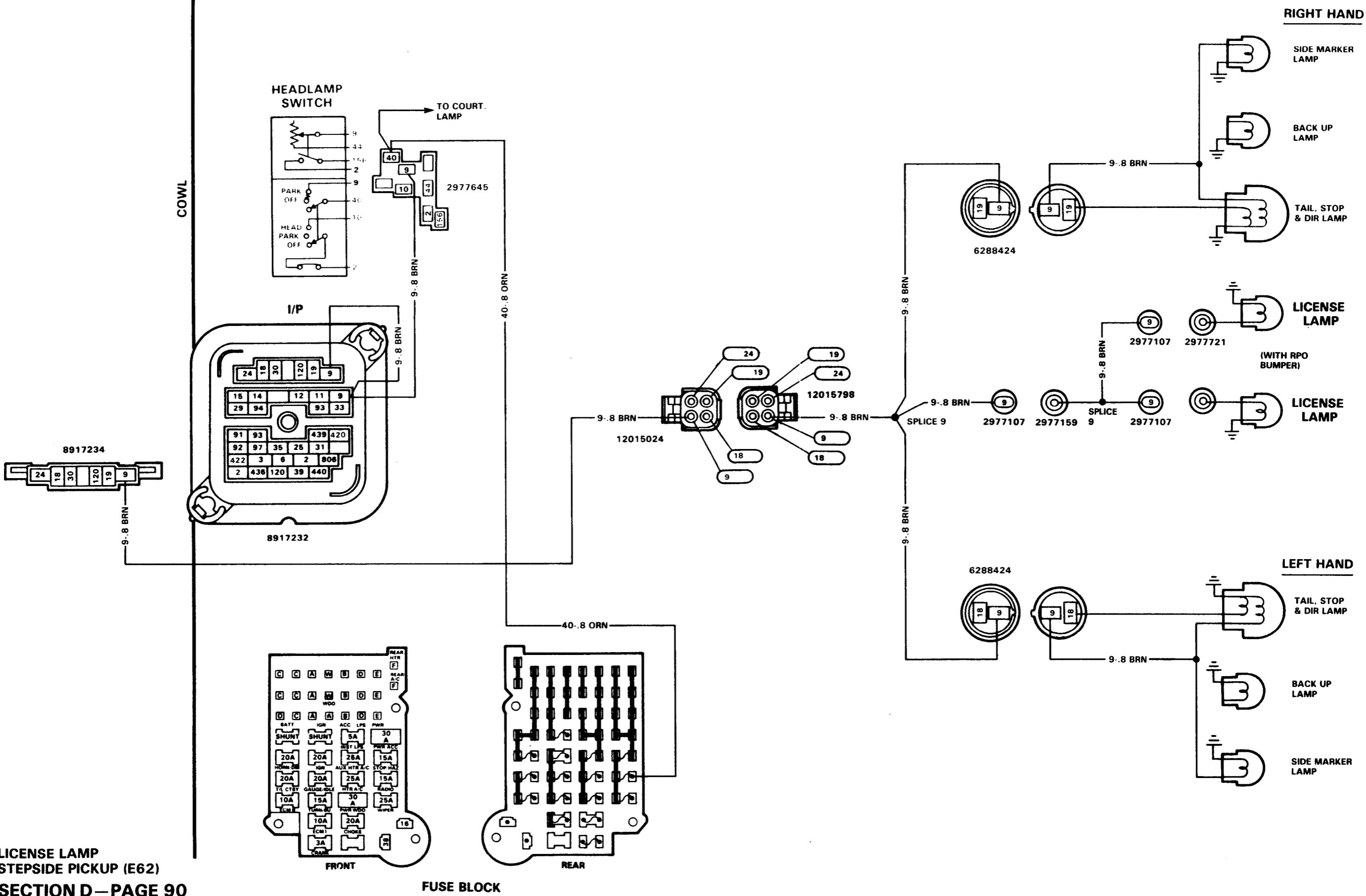

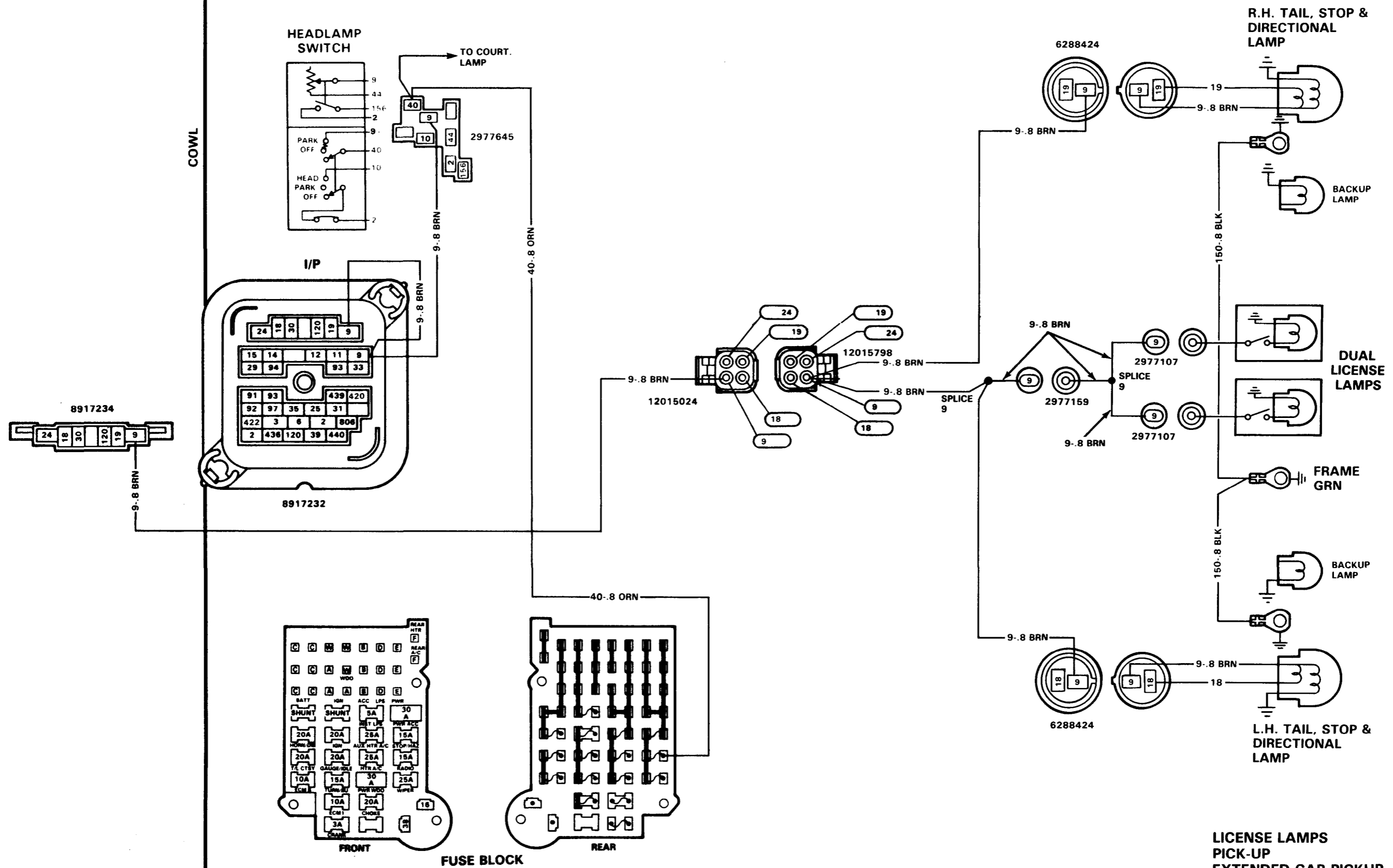

LICENSE LAMPS
 PICK-UP
 EXTENDED CAB PICKUP
 SECTION D—PAGE 91

JUNCTION BLOCK
(W/O TP2-AUX BATTERY)

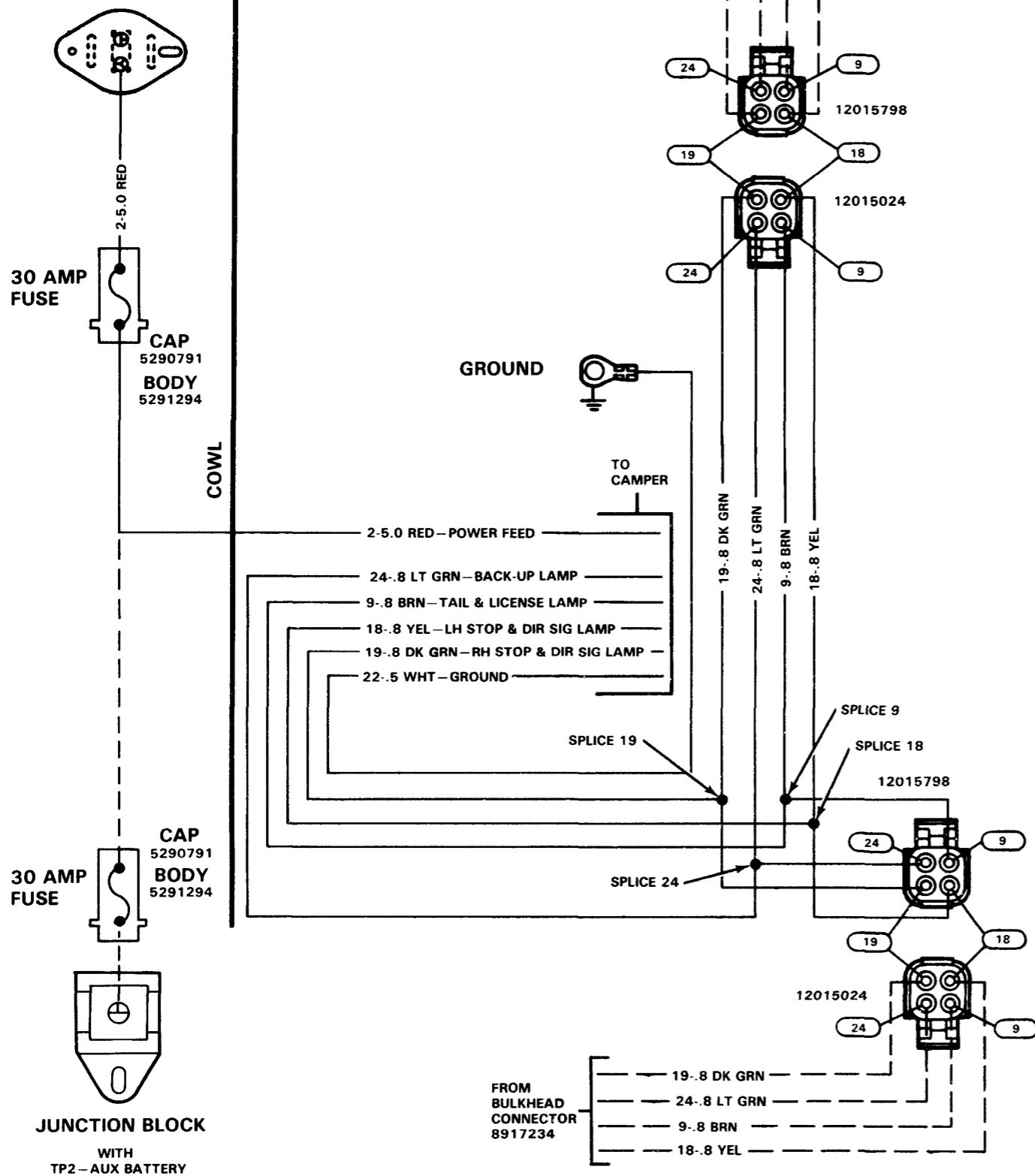

CAMPER & TRAILER WIRING
SECTION D-PAGE 92

CAMPER EQUIPMENT-RPO UY1

JUNCTION BLOCK
(W/O TP2-AUX BATTERY)

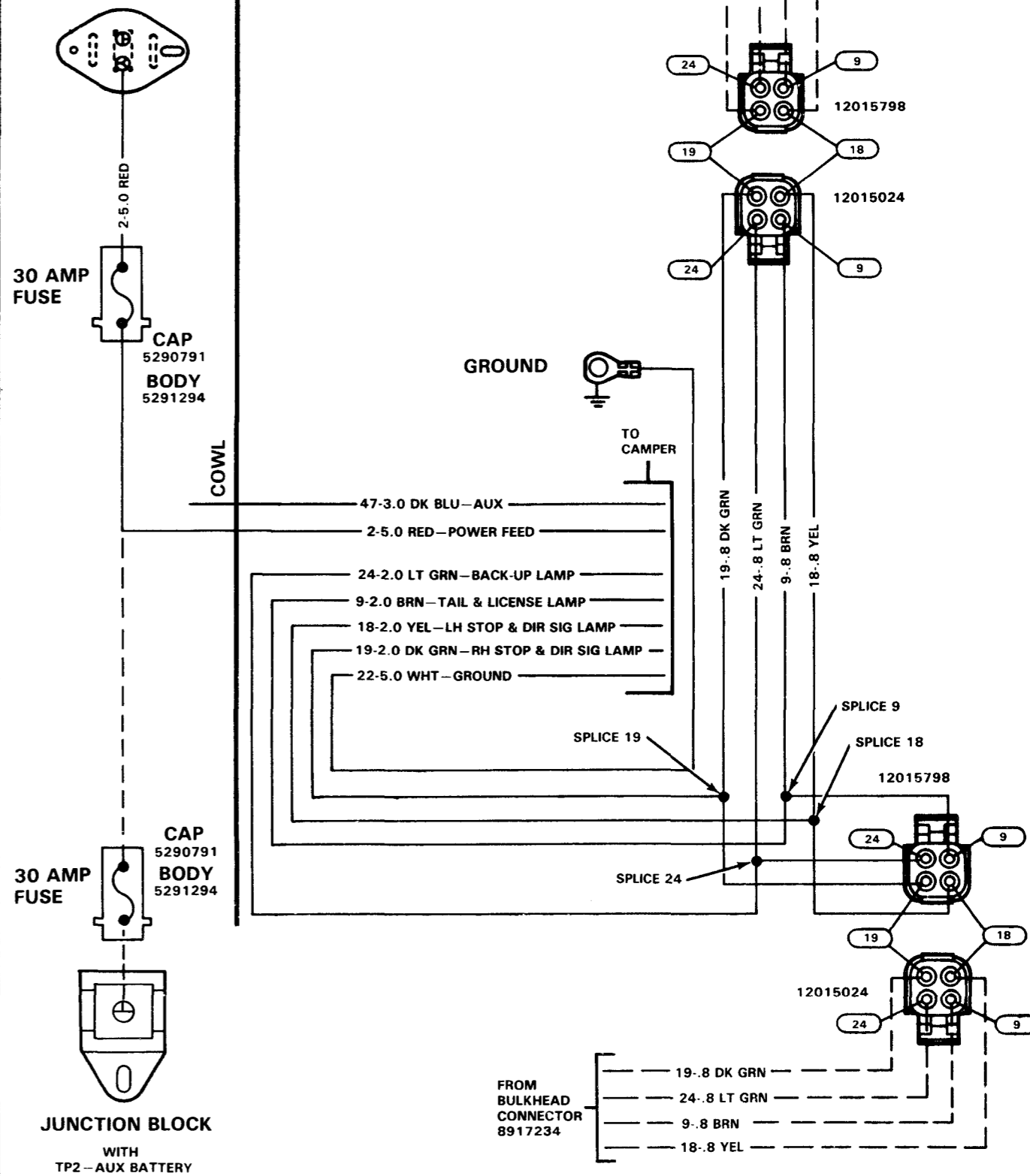

HEAVY DUTY TRAILER-RPO UY7

1988 P CHASSIS

SECTION E

<u>PAGE</u>	<u>DESCRIPTION</u>	<u>PAGE</u>	<u>DESCRIPTION</u>
2	POWER DISTRIBUTION (6 CYL.)	25	EMISSION CONTROLS (6 CYL.)
3	POWER DISTRIBUTION (8 CYL.)	26	EMISSION CONTROLS (8 CYL.)
7	POWER DISTRIBUTION (DIESEL)	27	EMISSION CONTROLS (DIESEL)
8	FUSE BLOCK DETAILS	28	ENGINE CONTROLS (DIESEL)
10	HEAD LAMPS & PARKING LAMPS	29	GLOW PLUGS (DIESEL)
11	MARKER LAMPS	30	ELECTRONIC CONTROL MODULE (ECM)—INPUTS (8 CYL.)
12	HAZARD LAMPS	32	ELECTRONIC CONTROL MODULE (ECM)—OUTPUTS (8 CYL.)
13	DIRECTIONAL LAMPS	34	ECM CHART (8 CYL.)
14	HORNS	35	AUTO TRANSMISSION KICKDOWN SOLENOID (M4Q)
15	WIPER/WASHER	36	BRAKE WARNING SYSTEM
16	START/IGNITION (6 CYL.)	38	INSTRUMENT PANEL LAMPS
17	START/IGNITION (8 CYL.)	39	INSTRUMENT PANEL GAGES
19	START/IGNITION (DIESEL)	40	INDICATOR LAMPS
23	THROTTLE BODY INJECTION	42	BACKUP LAMPS
24	FUEL CONTROL & IDLE AIR CONTROL (8 CYL.)	43	TAIL LAMPS
		44	LICENSE LAMPS

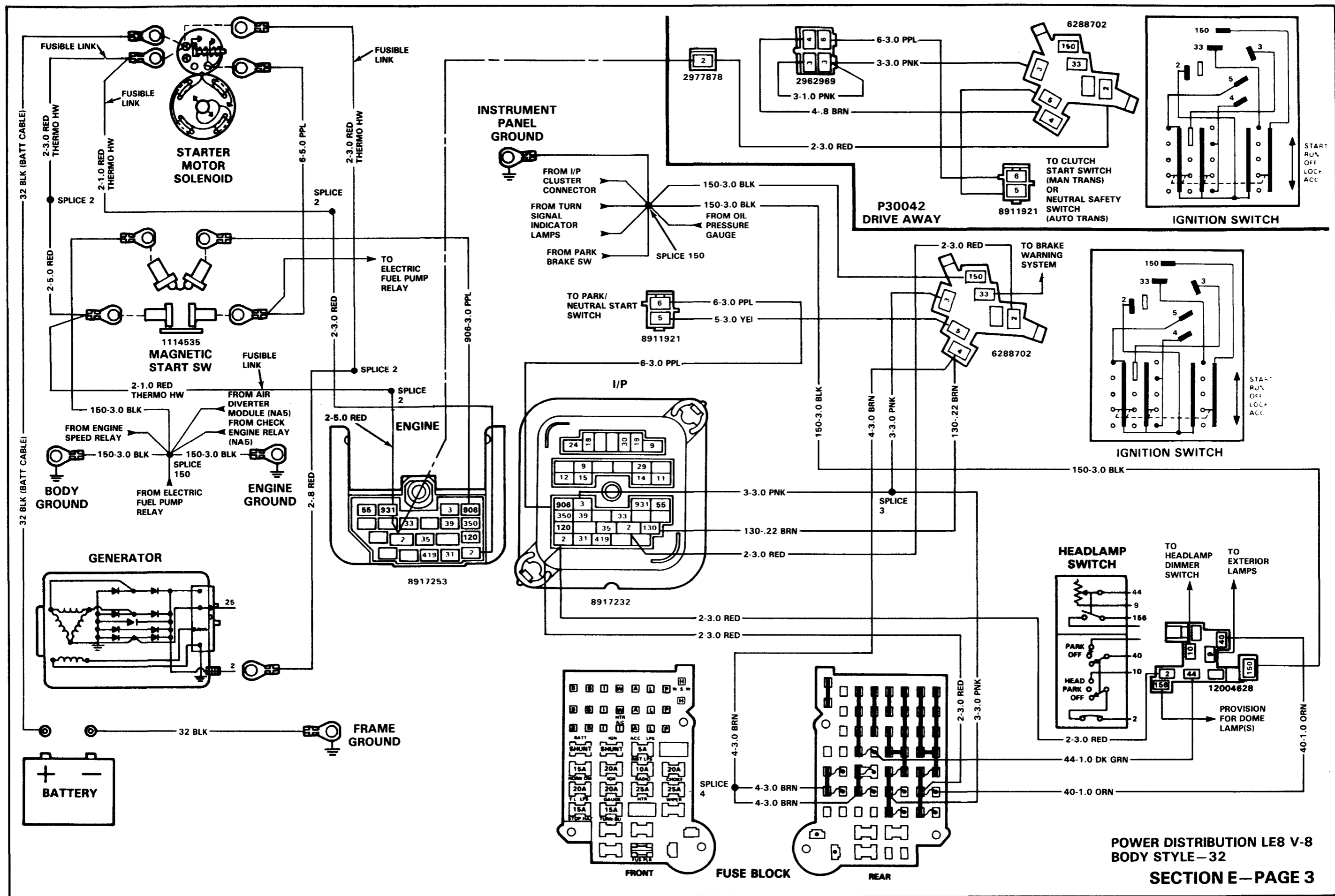

POWER DISTRIBUTION LE8 V-8
 BODY STYLE-32
 SECTION E-PAGE 3

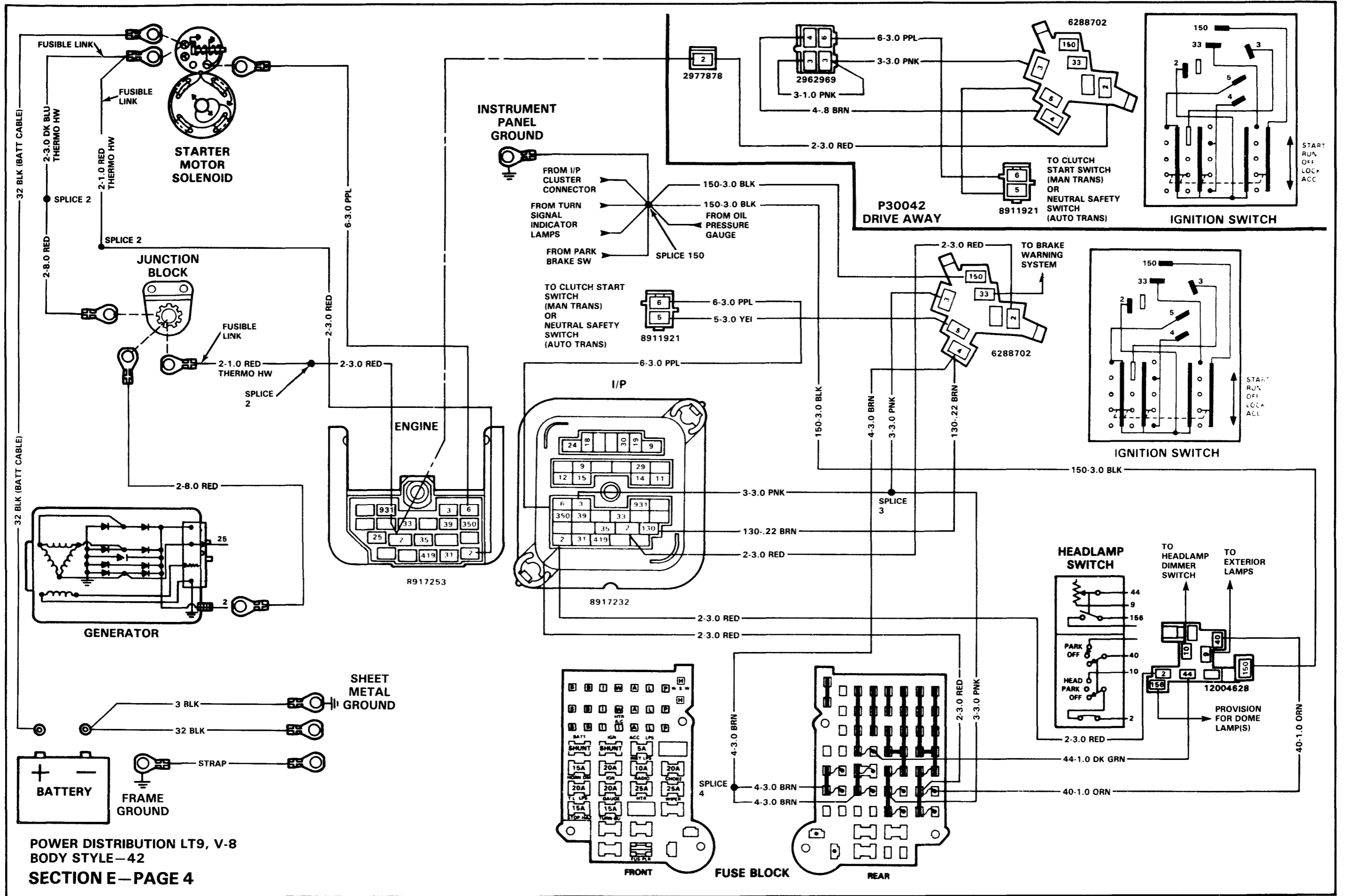

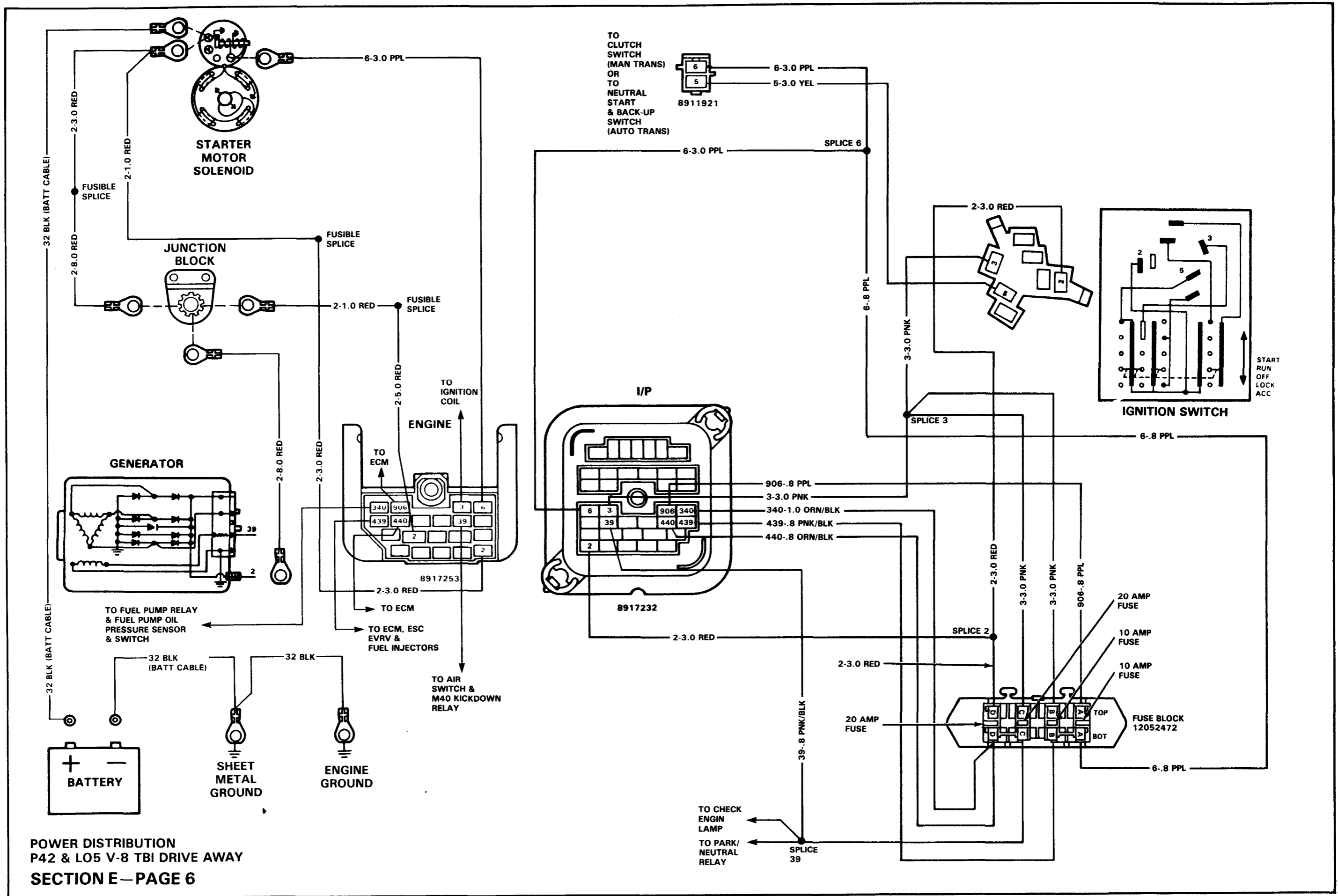

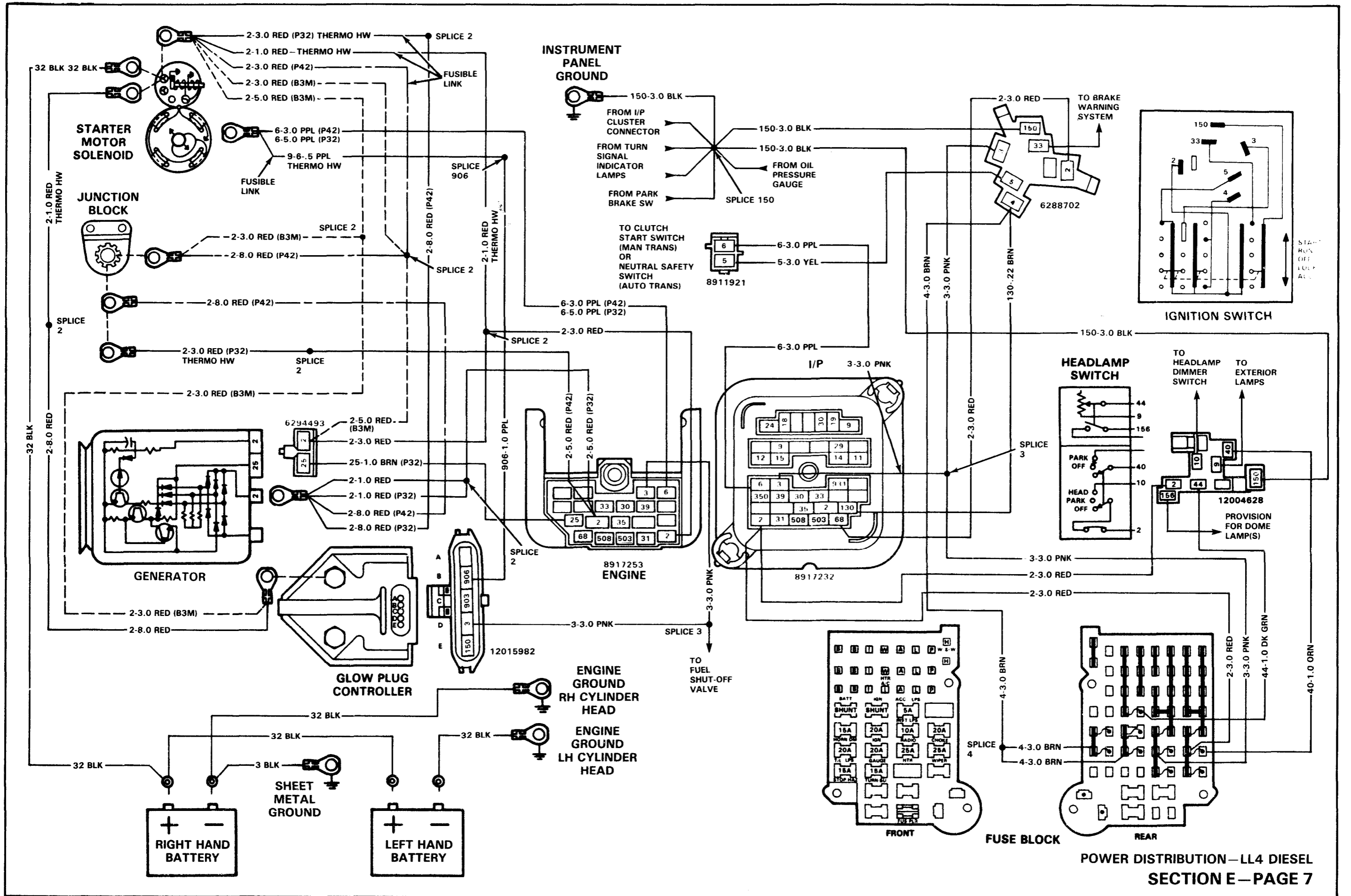

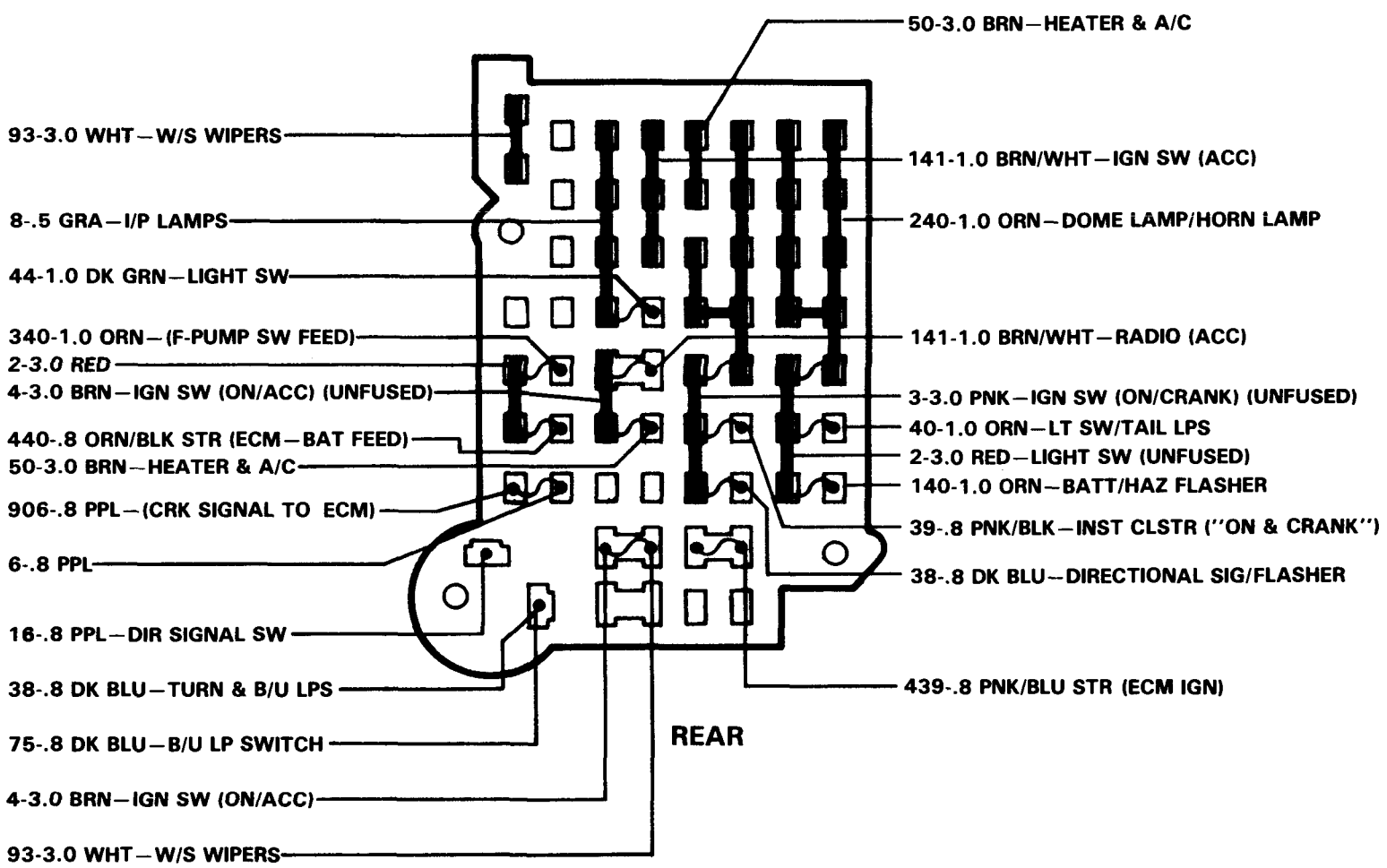
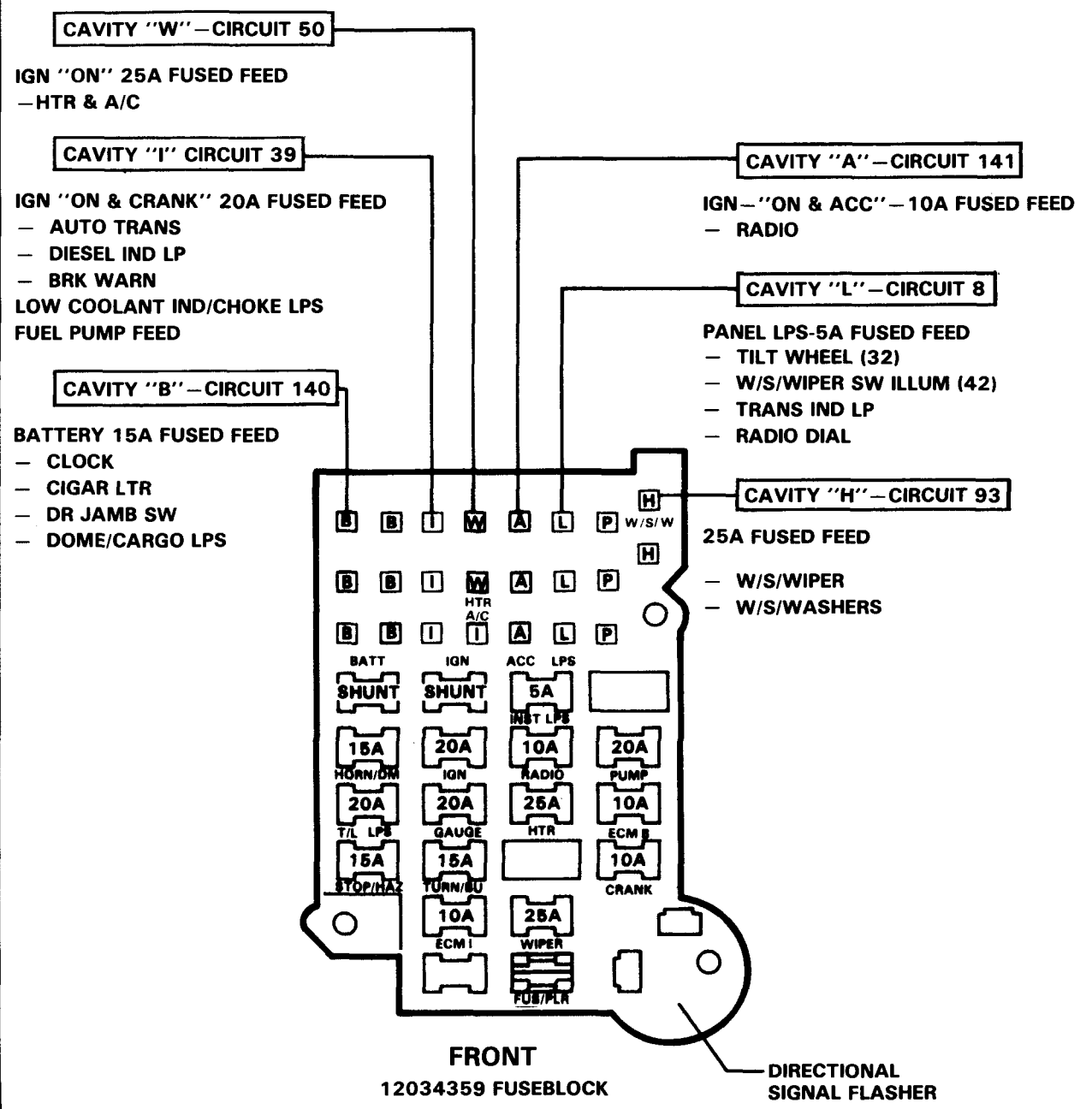

	COLOR	MALE CONN
I	NAT	12004888
A	BRN	12004887
B	BLK	12004886
L	GRN	12004885
P	RED	12004883
W	BLU	12004884
H	DK GRA	12004740

FUSES	AMP	COLOR
12004005	5	TAN
12004007	10	RED
12004008	15	LT BLU
12004009	20	YEL
12004010	25	WHT
12004003	3	VIOLET
12004006	75	BROWN
12004011	30	LT GRN

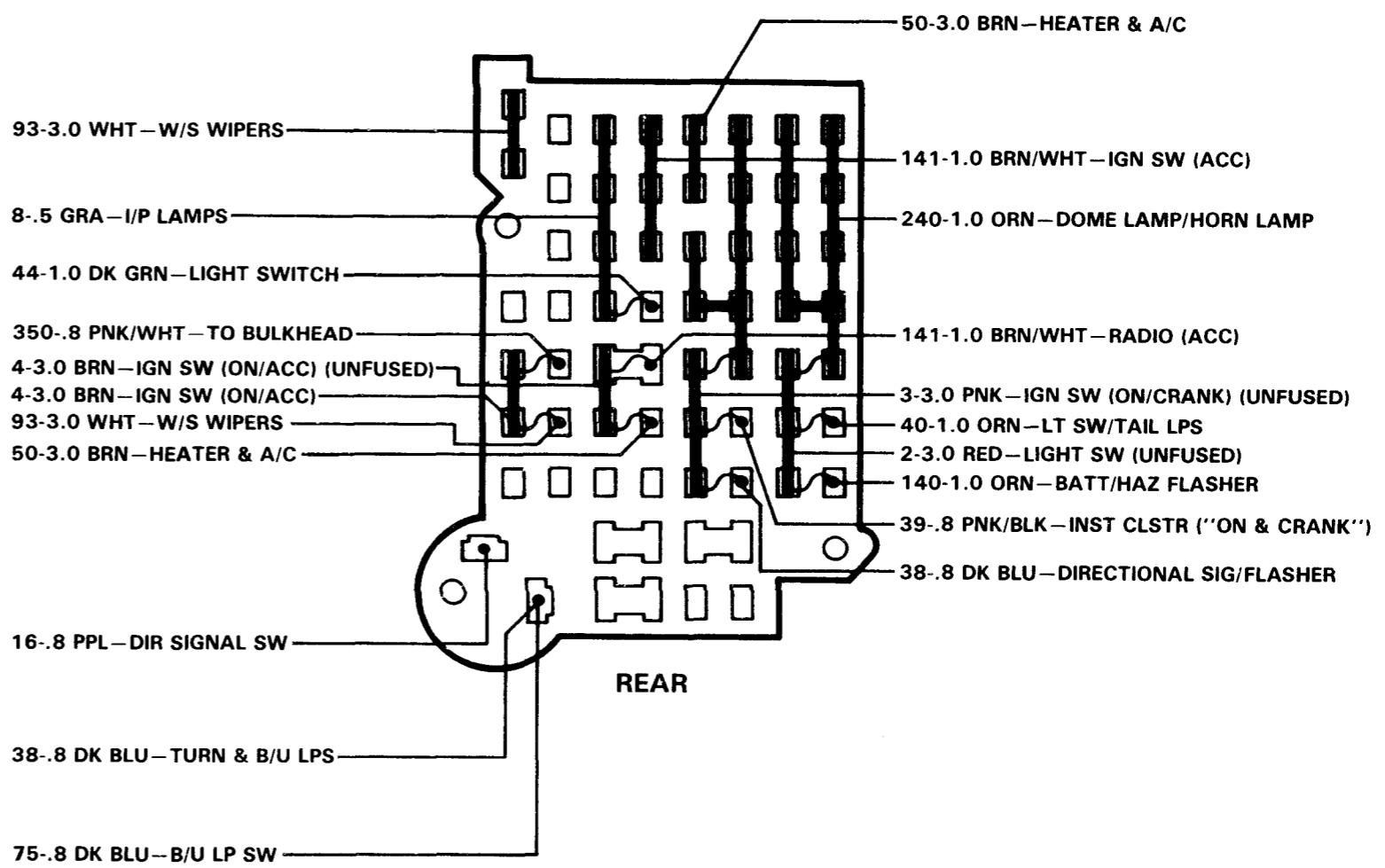
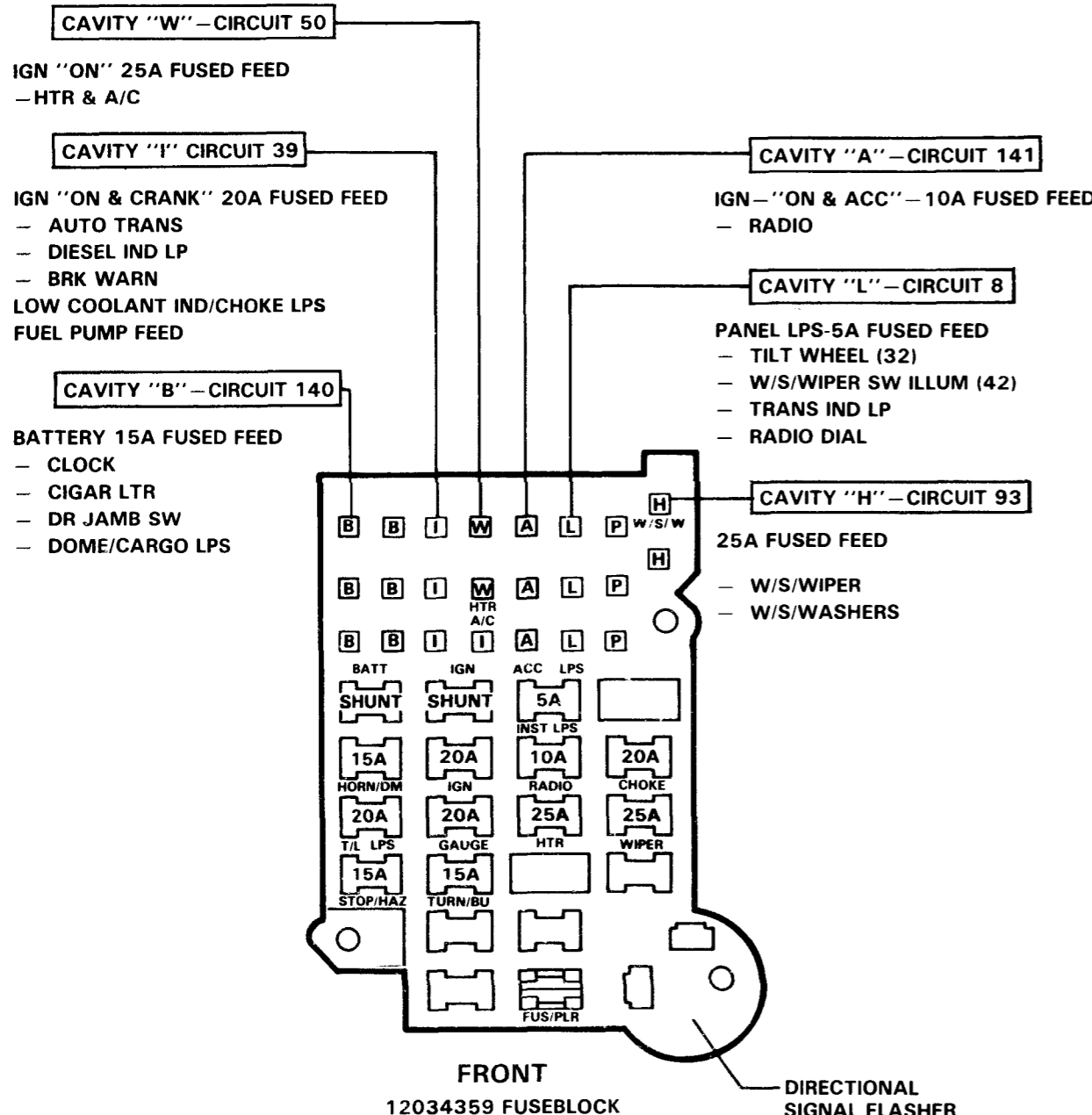

	COLOR	MALE CONN
I	NAT	12004888
A	BRN	12004887
B	BLK	12004886
L	GRN	12004885
P	RED	12004883
W	BLU	12004884
H	DK GRA	12004740

FUSES	AMP	COLOR
12004005	5	TAN
12004007	10	RED
12004008	15	LT BLU
12004009	20	YEL
12004010	25	WHT
12004003	3	VIOLET
12004006	75	BROWN
12004011	30	LT GRN

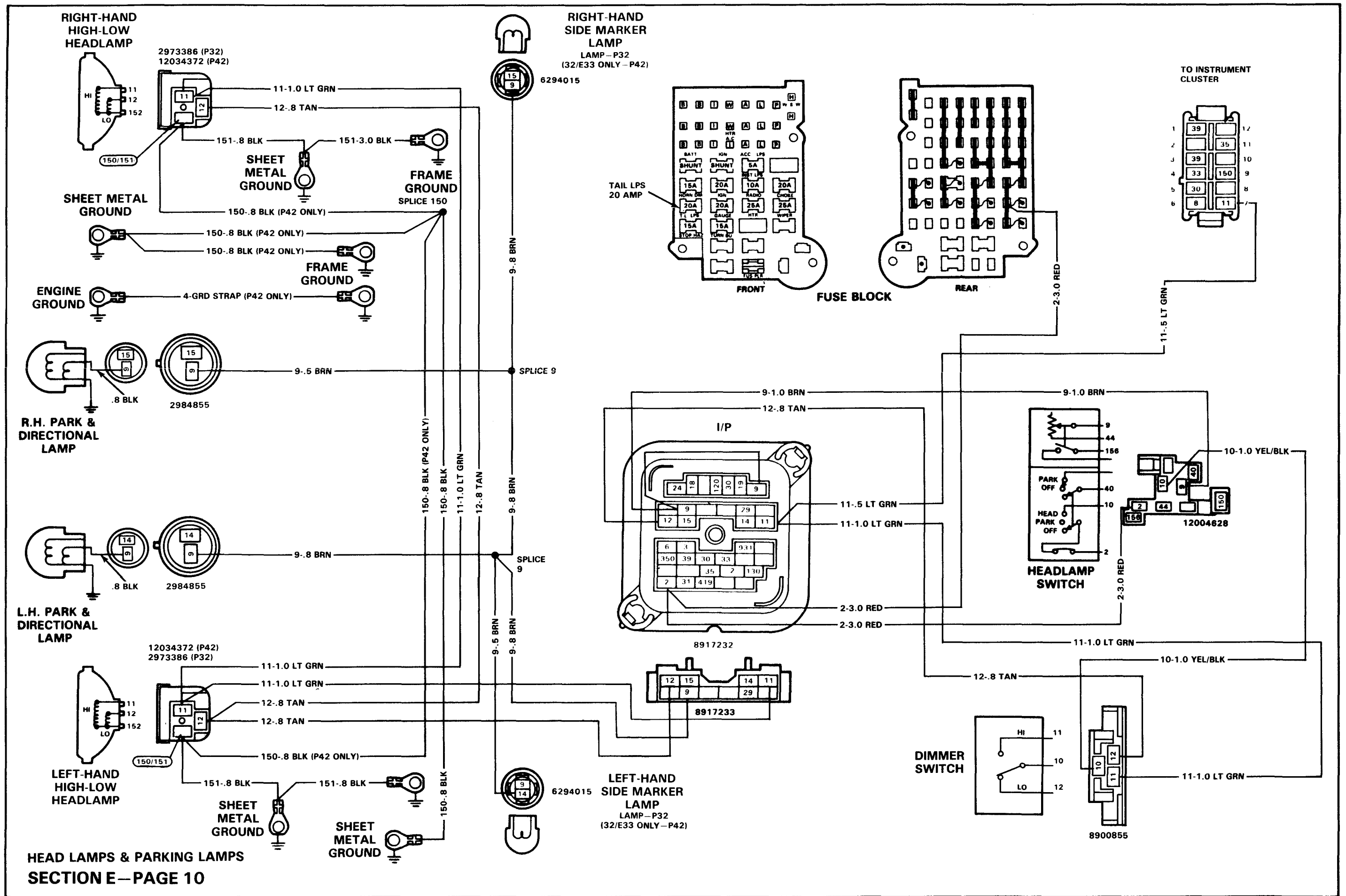

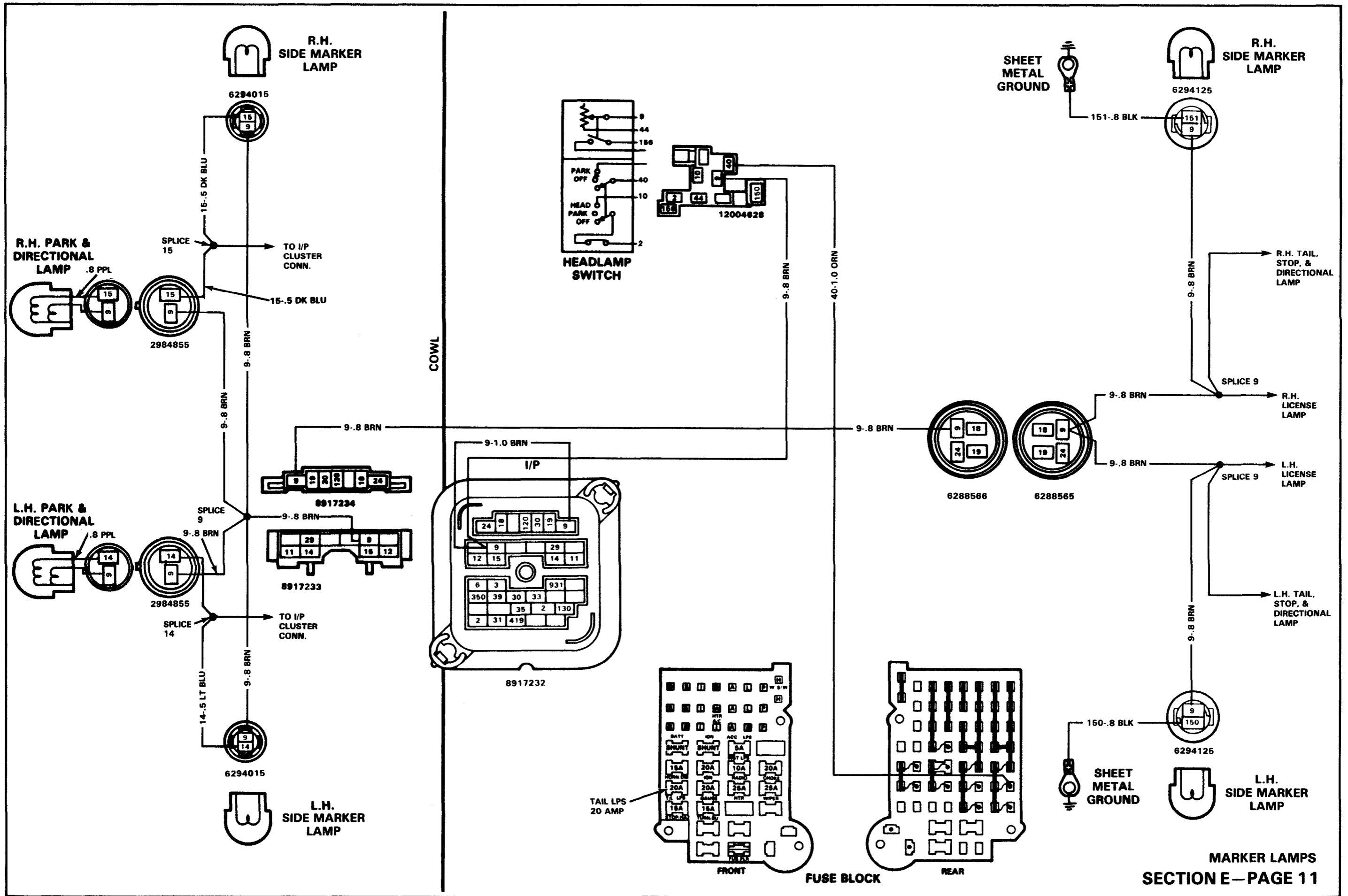

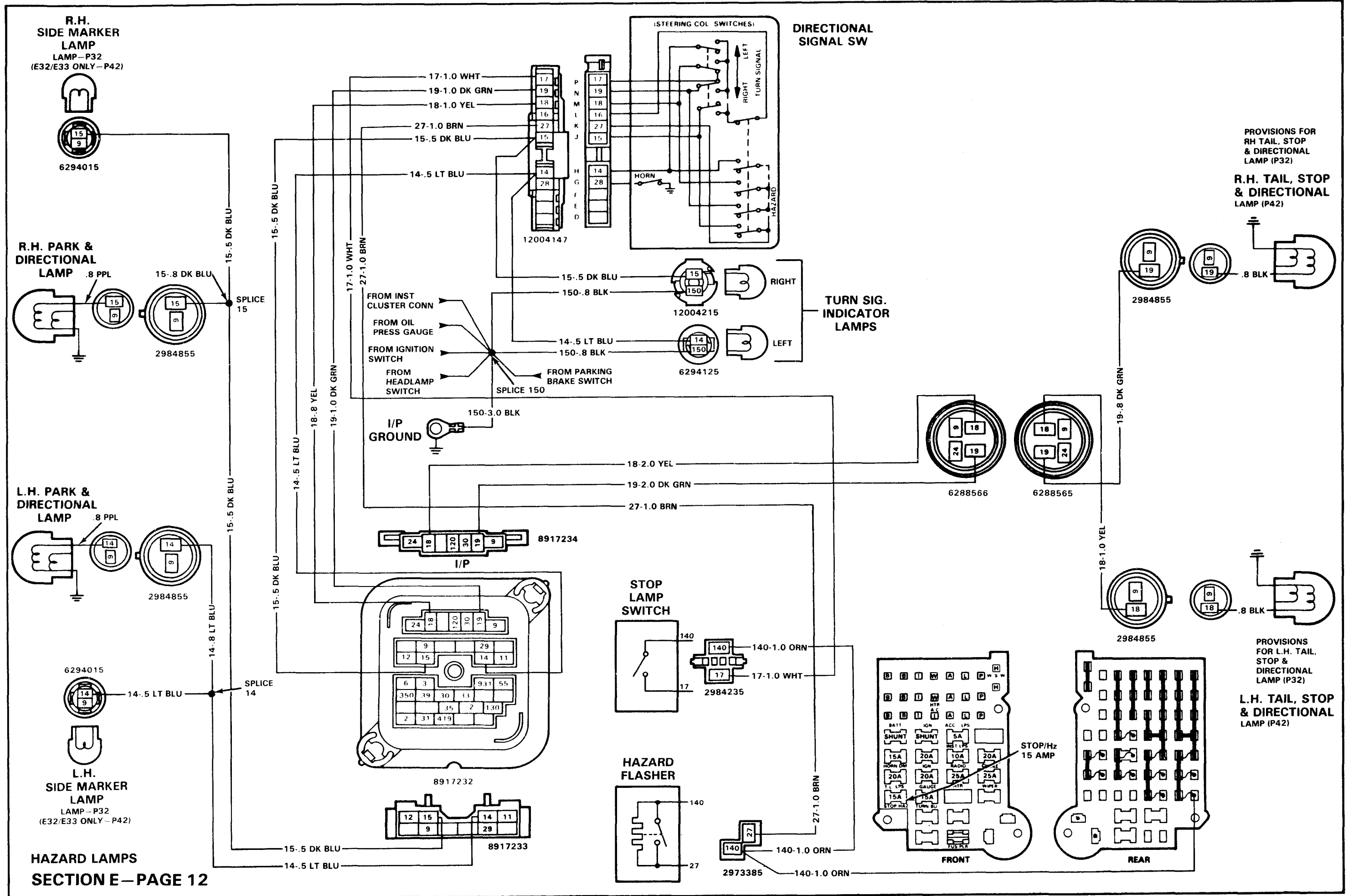

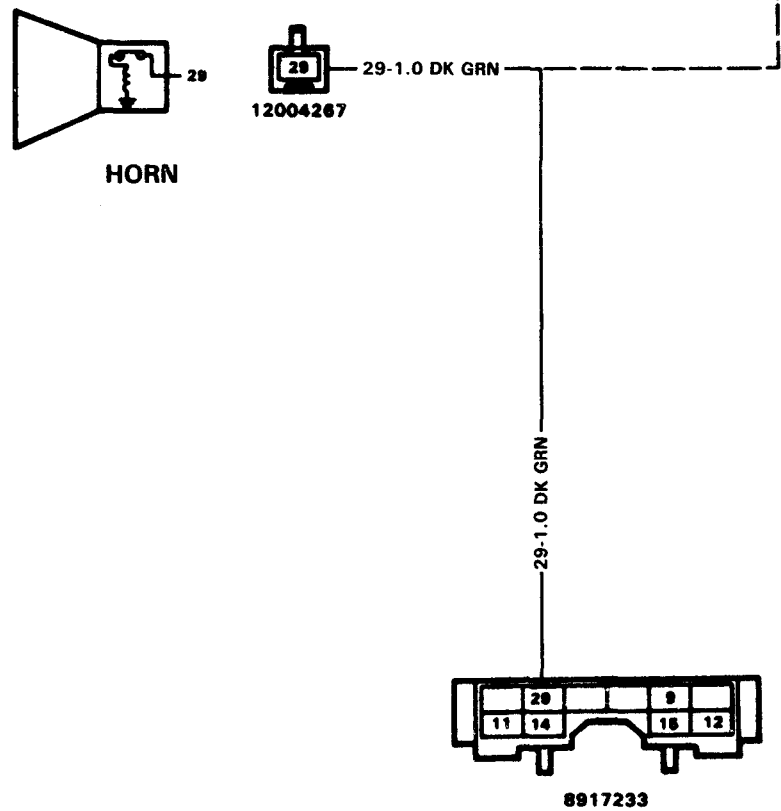
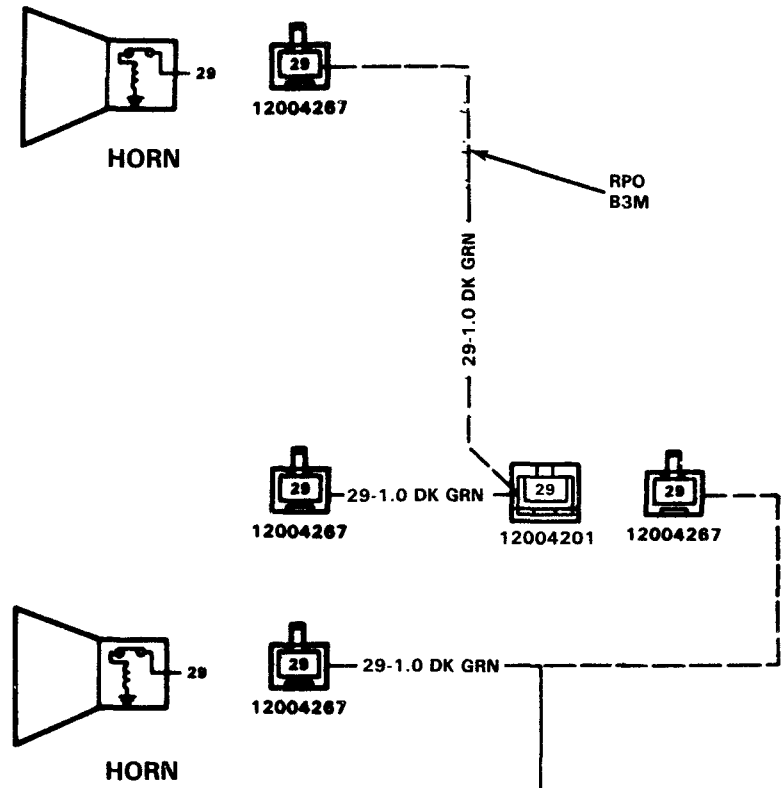

COWL

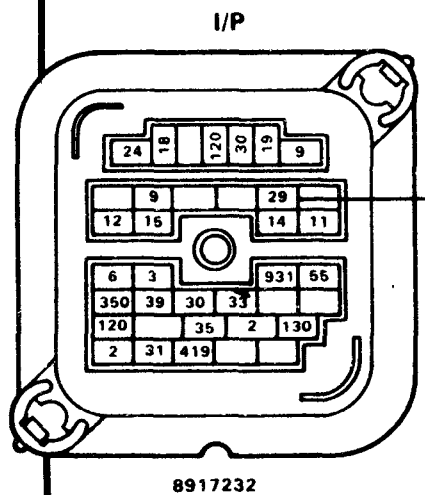

HORN RELAY

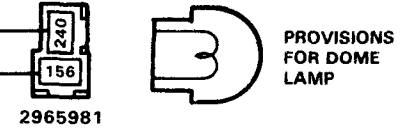
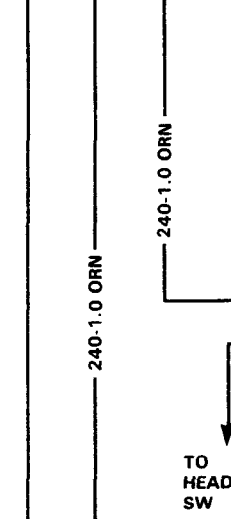
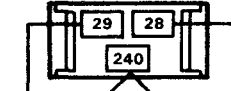
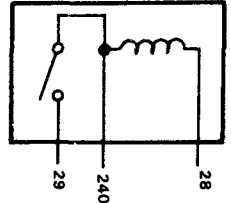

TO HEADLAMP SW

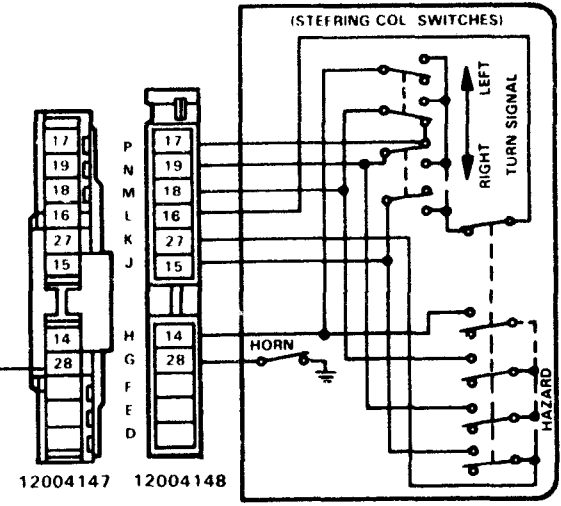

DIRECTIONAL SIGNAL SW

HORN/DIM 15A

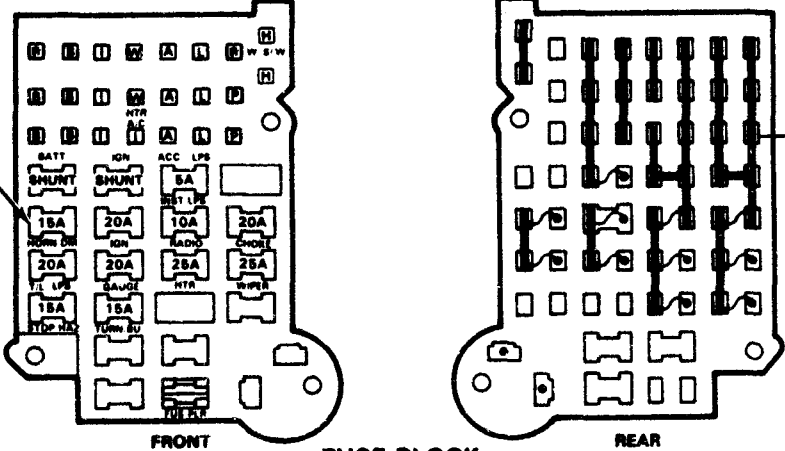

FUSE BLOCK

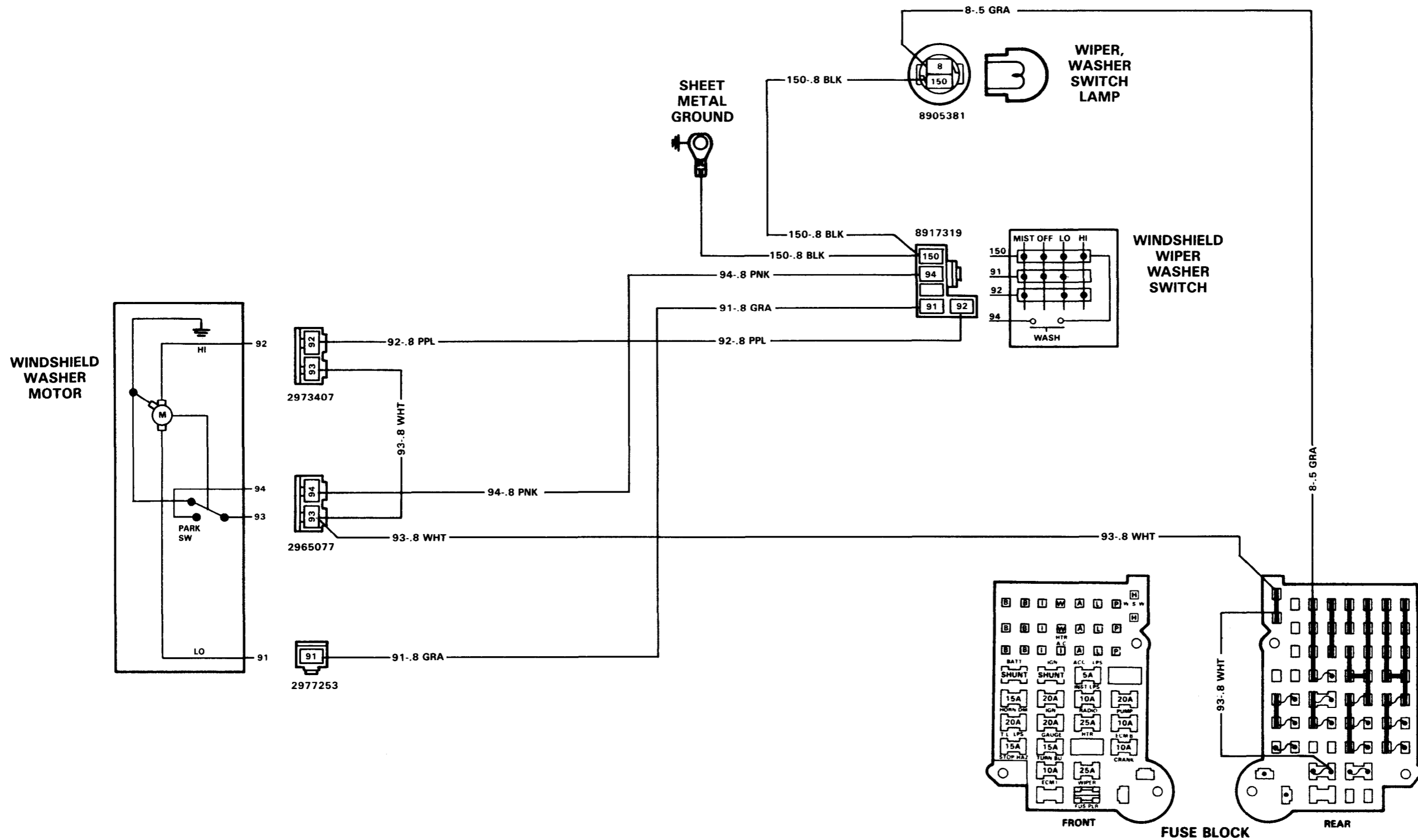

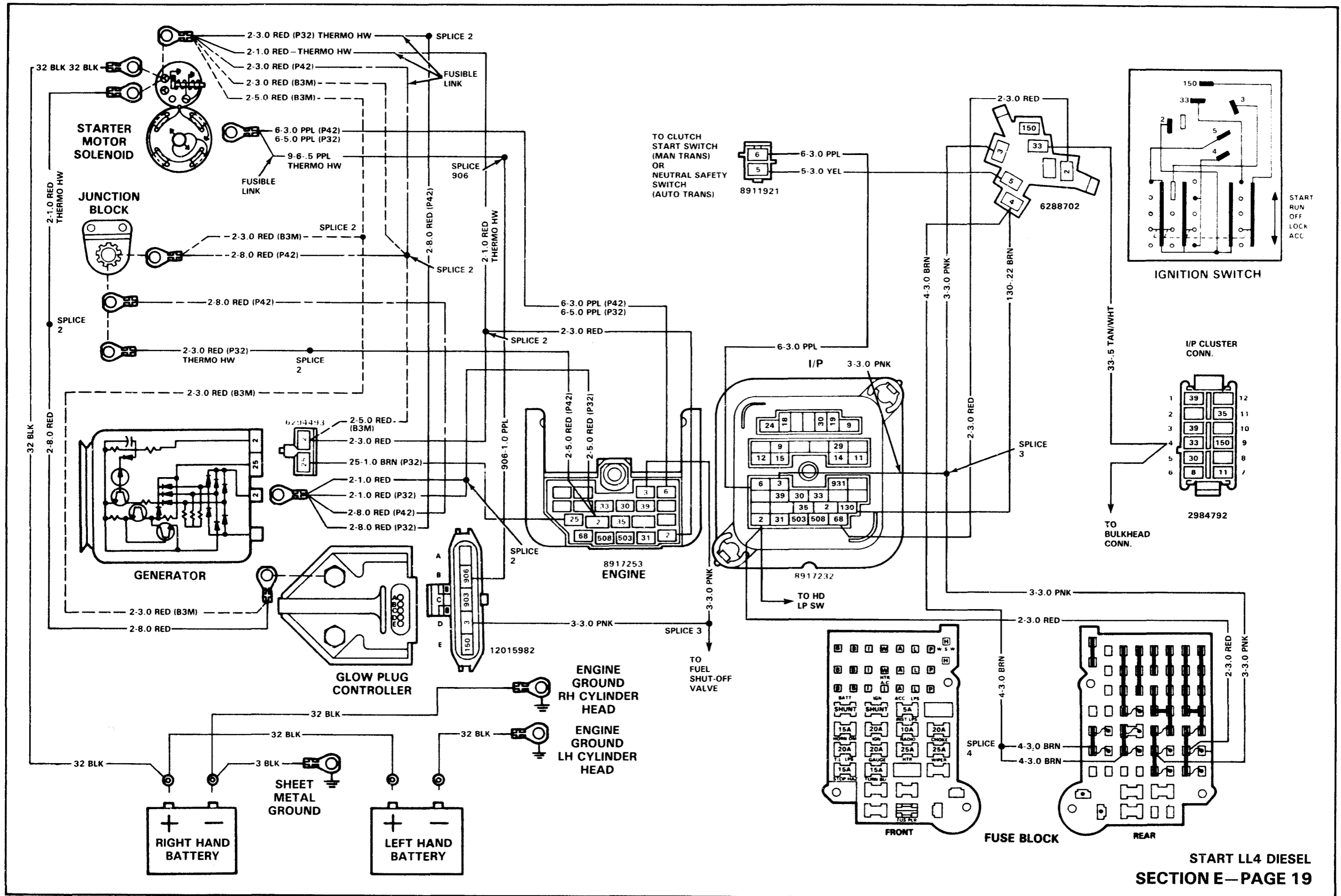

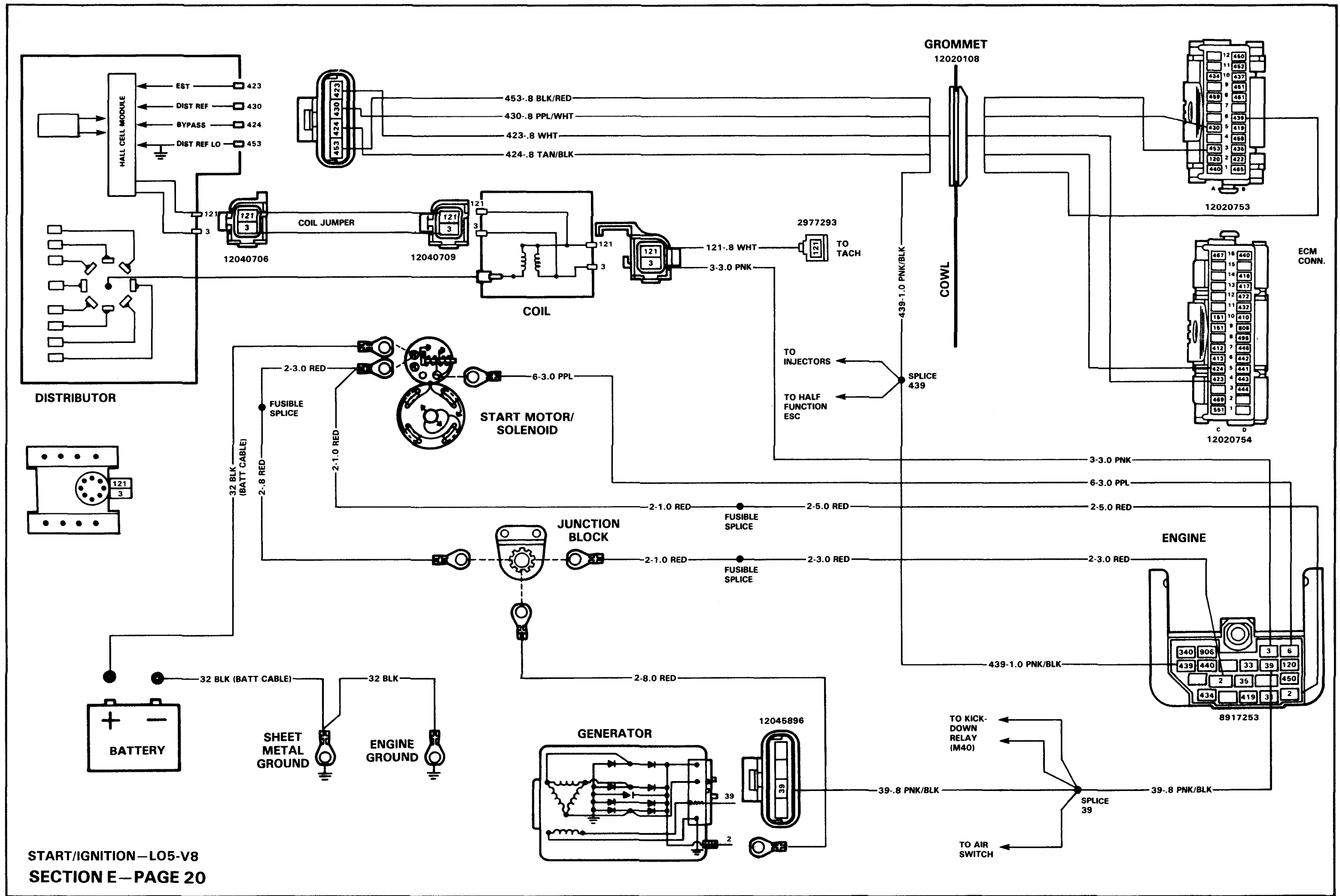

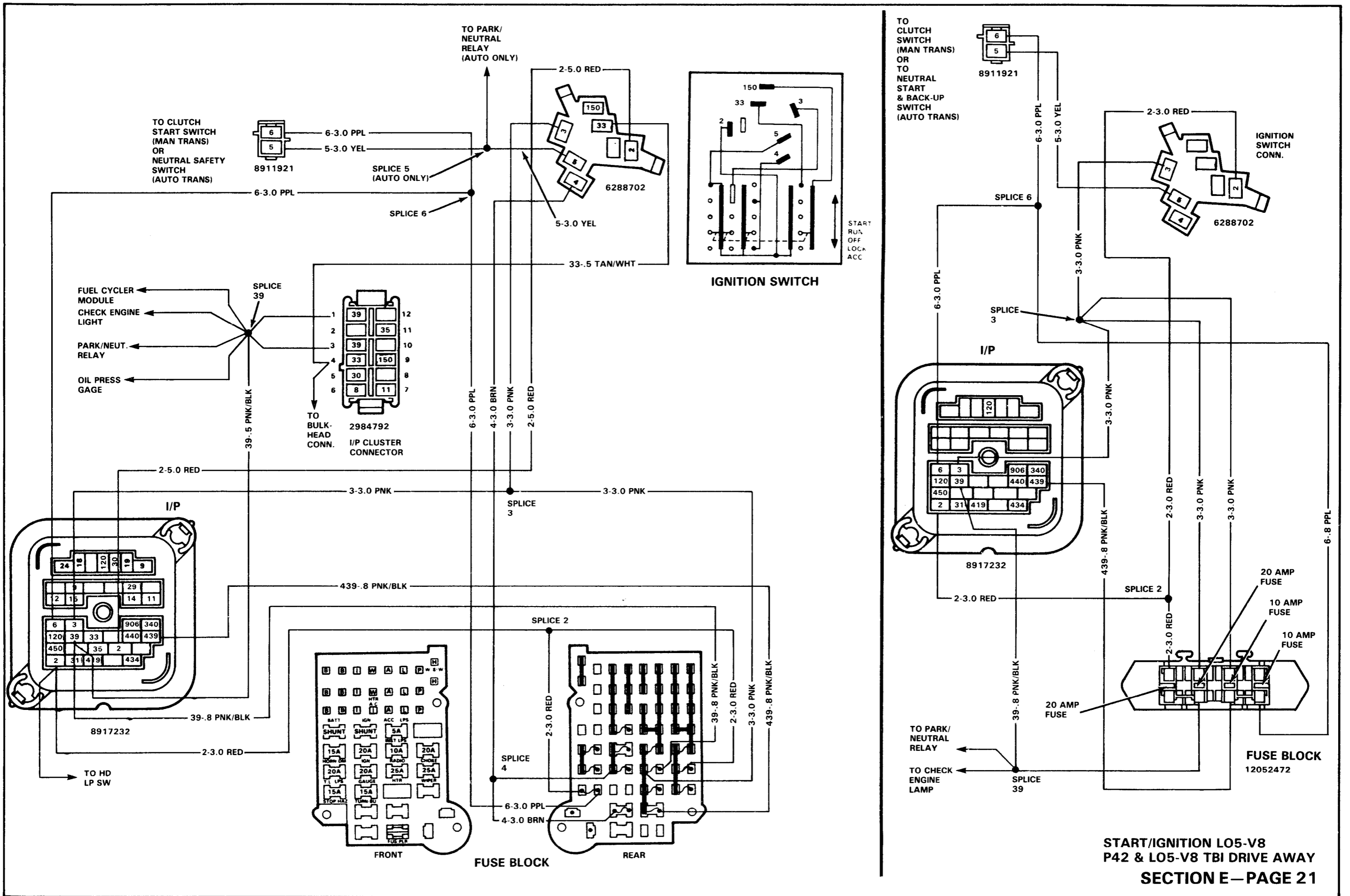

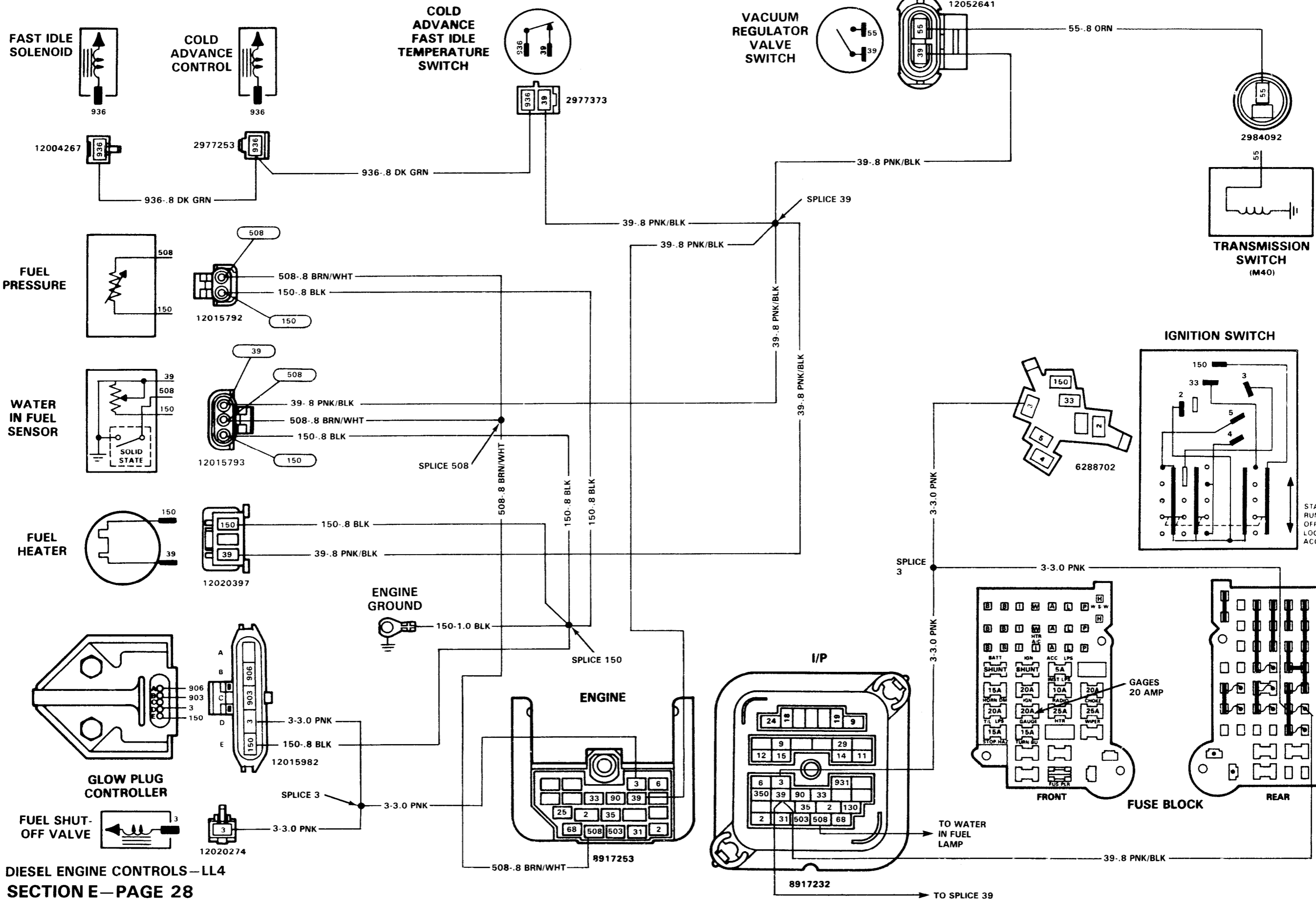

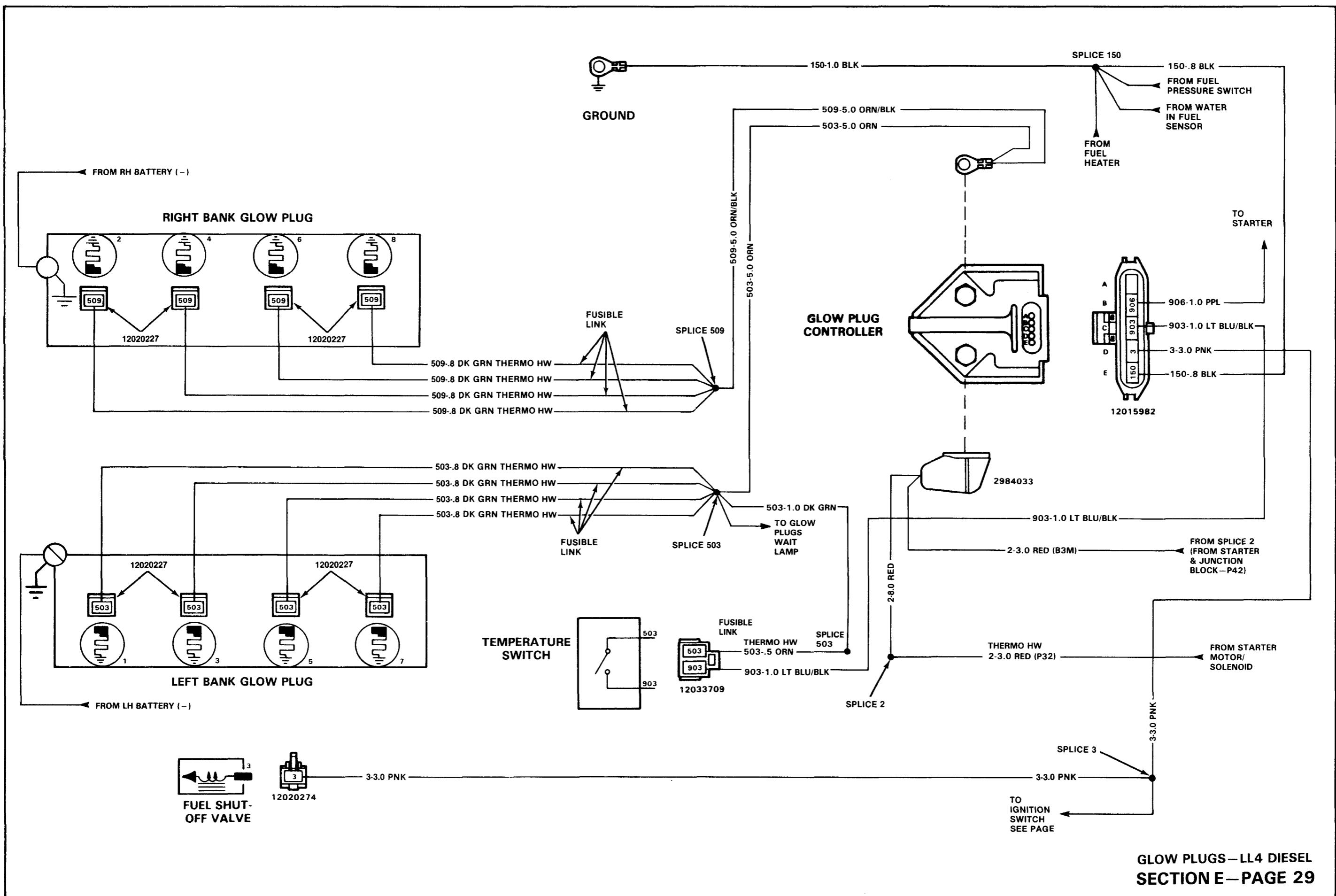

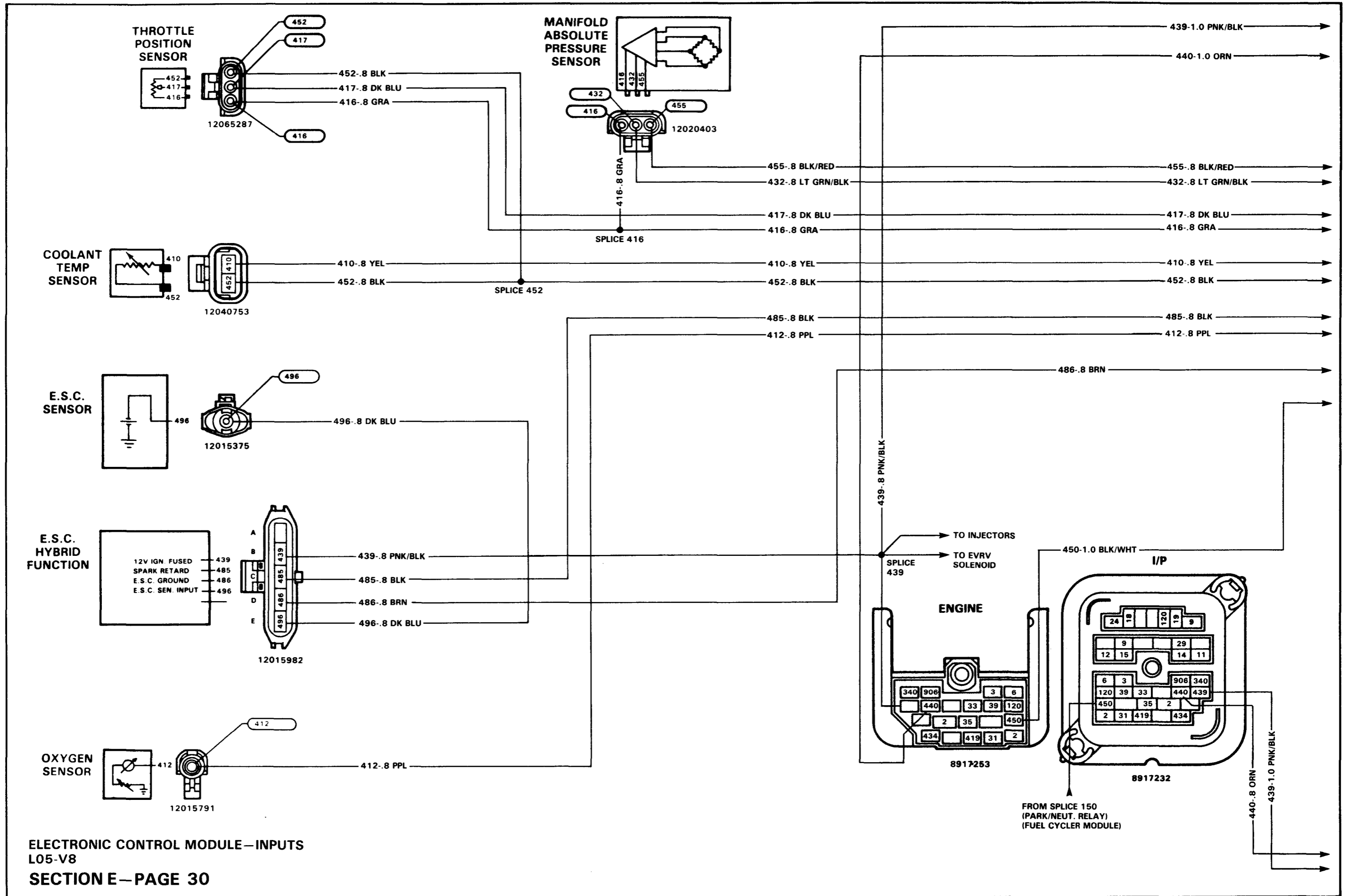

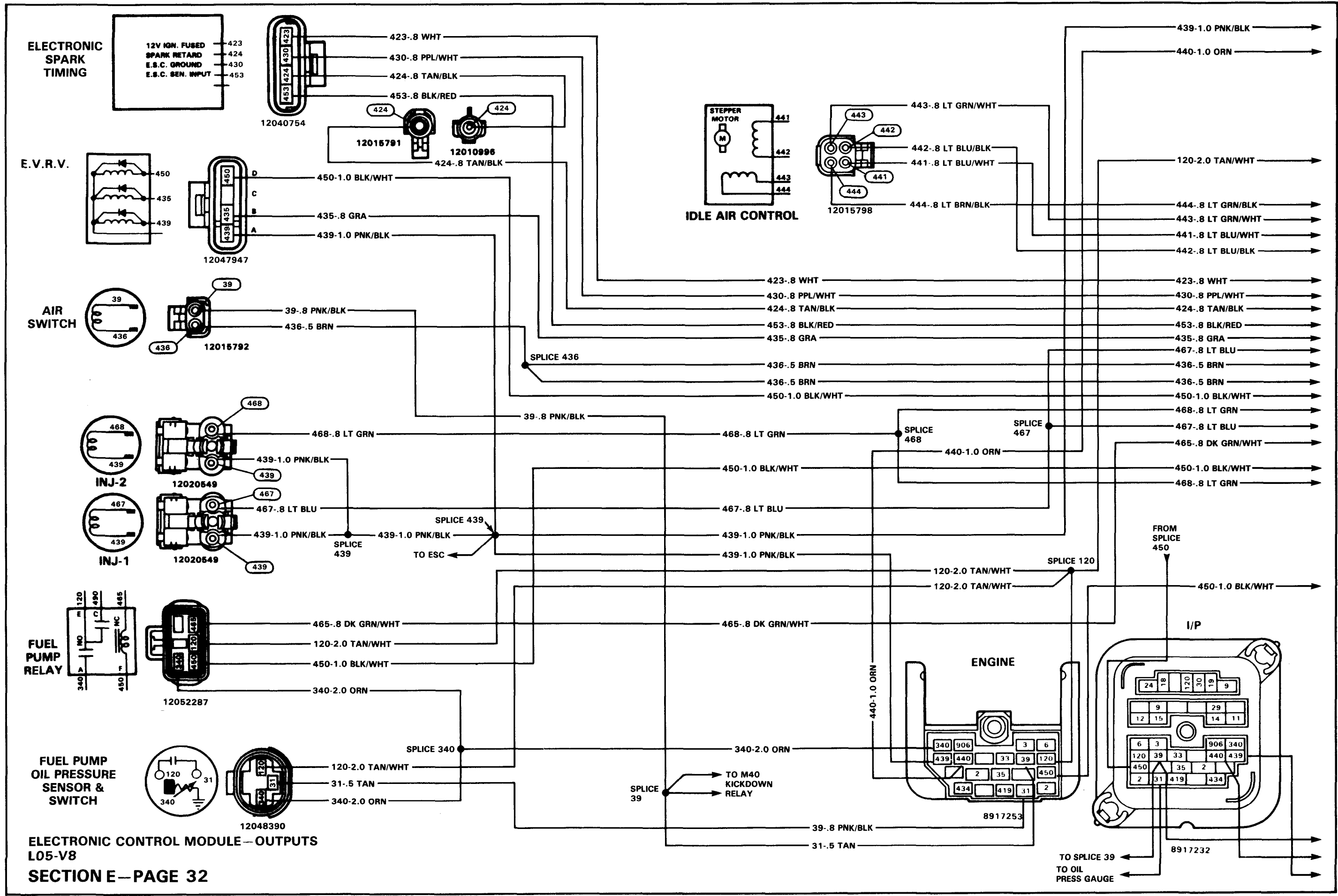

ELECTRONIC SPARK TIMING

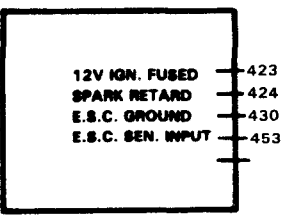

E.V.R.V.

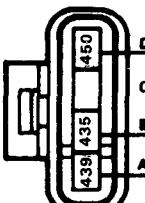
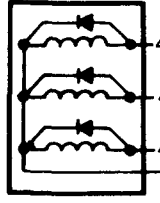

AIR SWITCH

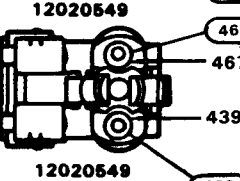
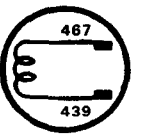
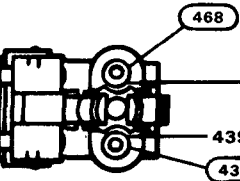
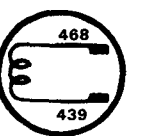
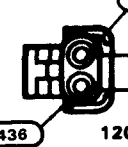
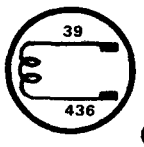

FUEL PUMP RELAY

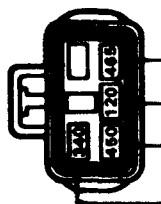
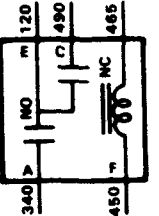

FUEL PUMP OIL PRESSURE SENSOR & SWITCH

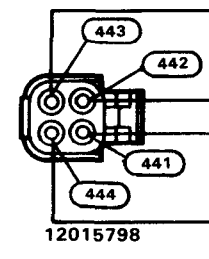
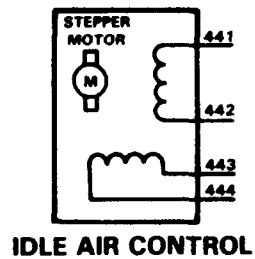
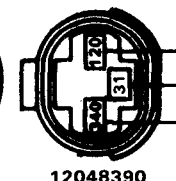
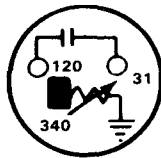

ENGINE

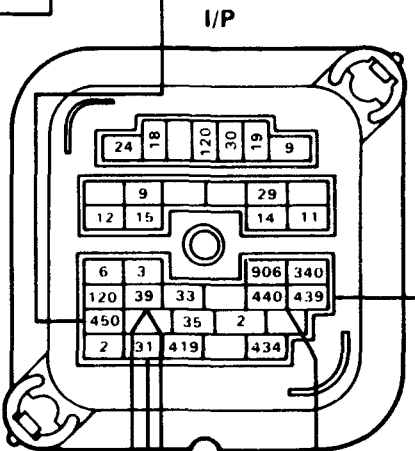
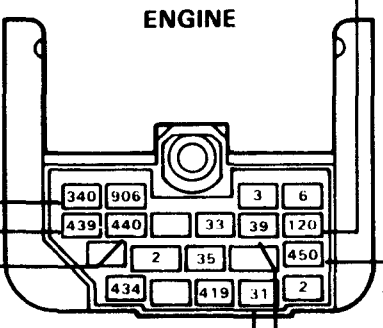

ELECTRONIC CONTROL MODULE—OUTPUTS L05-V8
SECTION E—PAGE 32

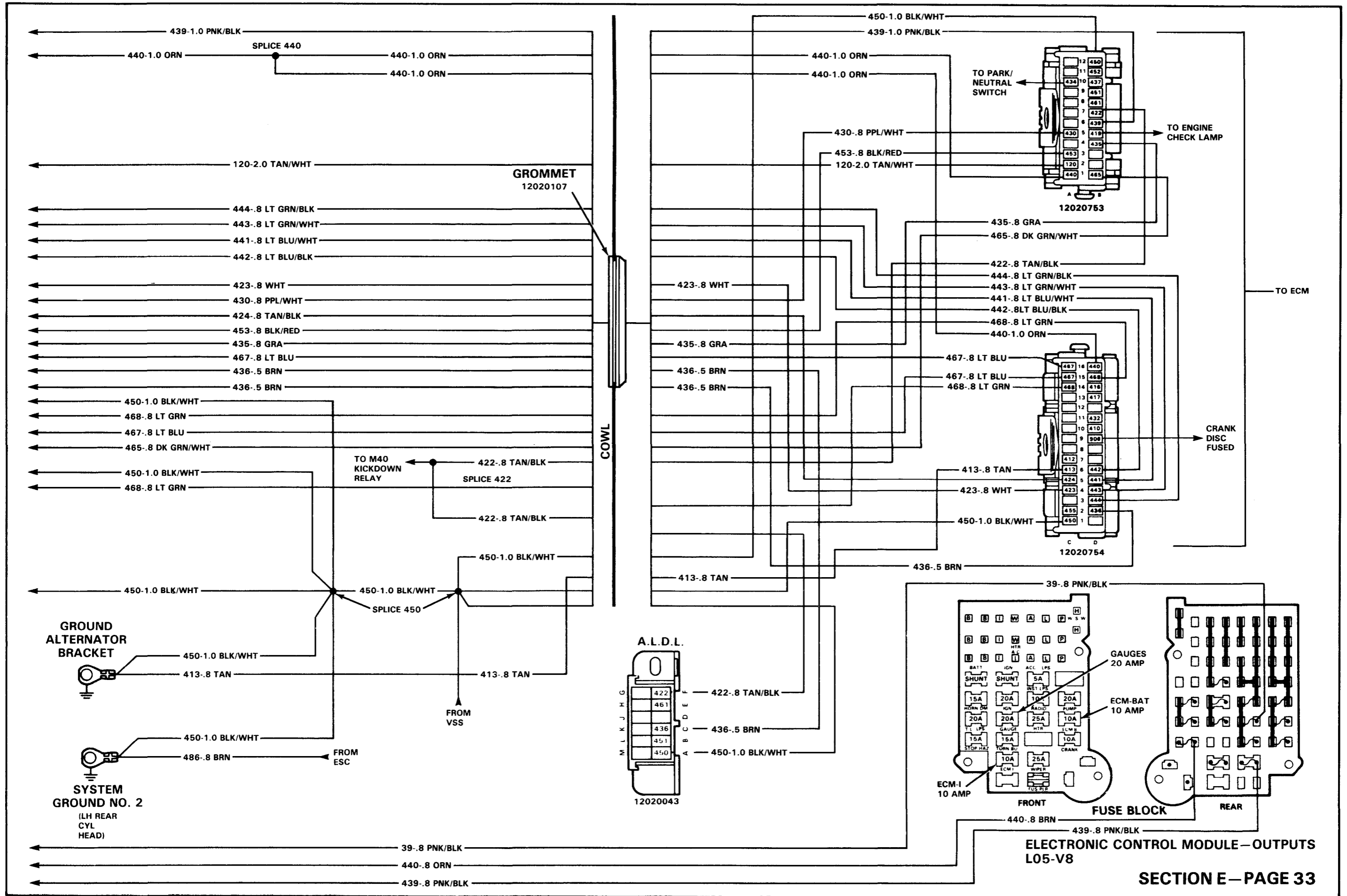

CIRCUIT NO.	WIRE SIZE	COLOR	CAVITY	DESCRIPTION
465	.8	DK GRN/WHT	A1	FUEL PUMP RELAY DRIVE
			A2	NOT USED
			A3	NOT USED
435	.8	GRA	A4	EVRV
419	.8	BRN/WHT	A5	SYSTEM CHECK LAMP
439	1.0	PNK/BLK	A6	12V IGNITION FUSED
* 422	.8	TAN/BLK	A7	M40 KICKDOWN RELAY
456	.8	TAN/BLK	A7	UPSHIFT MAN— ONLY
461	.8	ORN	A8	SERIAL DATA
451	.8	WHT/BLK	A9	ASS'Y LINE DIAG/LINK
437	.8	BRN	A10	SPEED SENSOR
452	.8	BLK	A11	5V SYSTEM RETURN A
450	1.0	BLK/WHT	A12	SYSTEM RETURN
440	1.0	ORN	B1	12V BATTERY FUSED
120	2.0	TAN/WHT	B2	ELEC FUEL PUMP FUSED FEED
453	.8	BLK/RED	B3	DISTRIBUTOR REF LOW
			B4	NOT USED
430	.8	PPL/WHT	B5	DISTRIBUTOR REF HIGH
			B6	NOT USED
485	.8	BLK	B7	SPARK RETARD CONTROL
			B8	NOT USED
			B9	NOT USED
* 434	.8	ORN/BLK	B10	PARK/NEUTRAL SWITCH
			B11	NOT USED
			B12	NOT USED

* AUTO TRANS ONLY

CIRCUIT NO.	WIRE SIZE	COLOR	CAVITY	DESCRIPTION
			C1	NOT USED
436	.5	BRN	C2	AIR SW SOLENOID
444	.8	LT GRN/BLK	C3	STEPPER COIL B LOW
443	.8	LT GRN/WHT	C4	STEPPER COIL B HIGH
441	.8	LT BLU/WHT	C5	STEPPER COIL A HIGH
442	.8	LT BLU/BLK	C6	STEPPER COIL A LOW
			C7	NOT USED
			C8	NOT USED
906	.8	PPL	C9	CRANK DISCRETE FUSED
410	.8	YEL	C10	COOLANT TEMPERATURE
432	.8	LT GRN	C11	MANIFOLD ABSOLUTE PRESS
			C12	NOT USED
417	.8	DK BLU	C13	THROTTLE POSITION SENSOR
416	.8	GRA	C14	5V SENSOR REFERENCE
468	.8	LT GRN	C15	INJECTOR B DRIVE
440	1.0	ORN	C16	12V BATTERY FUSED
450	1.0	BLK/WHT	D1	SYSTEM RETURN
455	.8	PPL	D2	5V RETURN A
			D3	NOT USED
423	.8	WHT	D4	HEI SPARK TIMING
424	.8	TAN/BLK	D5	HEI BYPASS
413	.8	TAN	D6	OXYGEN SENSOR LOW
412	.8	PPL	D7	OXYGEN SENSOR HIGH
			D8	NOT USED
			D9	NOT USED
			D10	NOT USED
			D11	NOT USED
			D12	NOT USED
			D13	NOT USED
468	.8	LT GRN	D14	INJECTOR B DRIVE
467	.8	LT BLU	D15	INJECTOR A DRIVE
467	.8	LT BLU	D16	INJECTOR A DRIVE

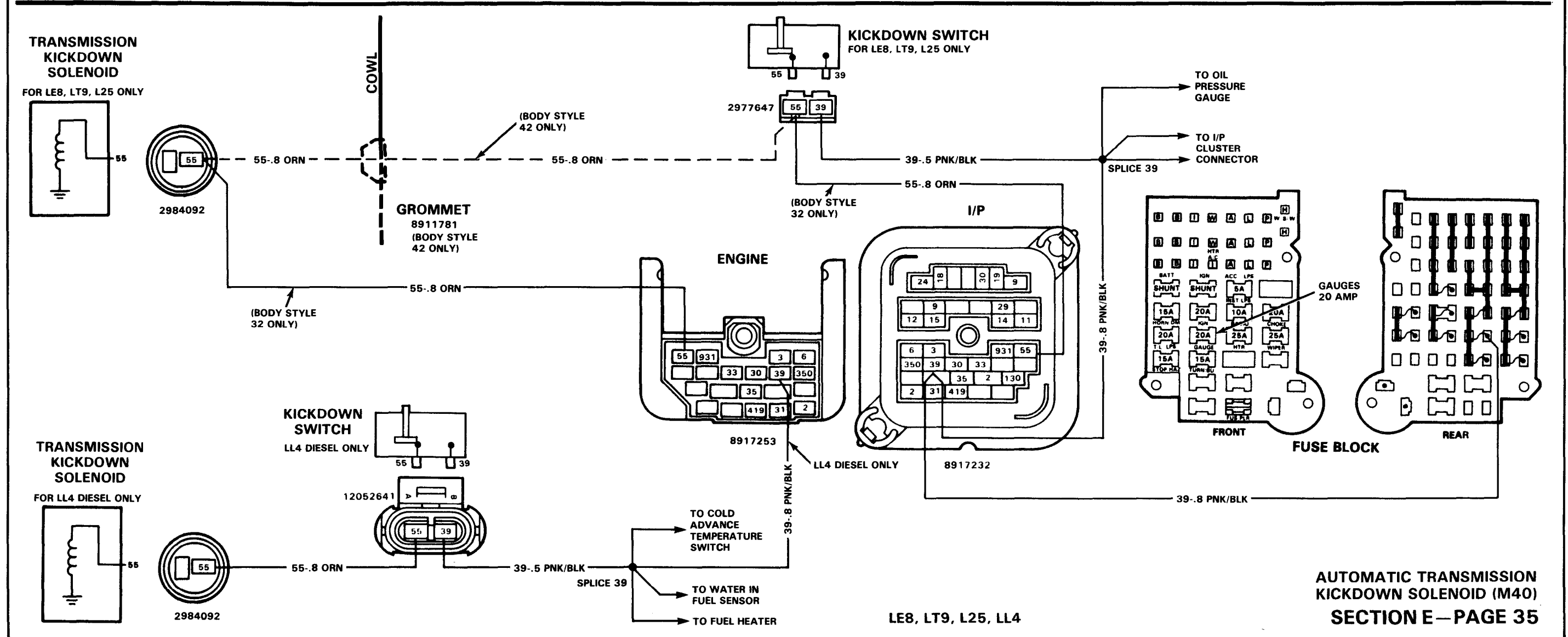
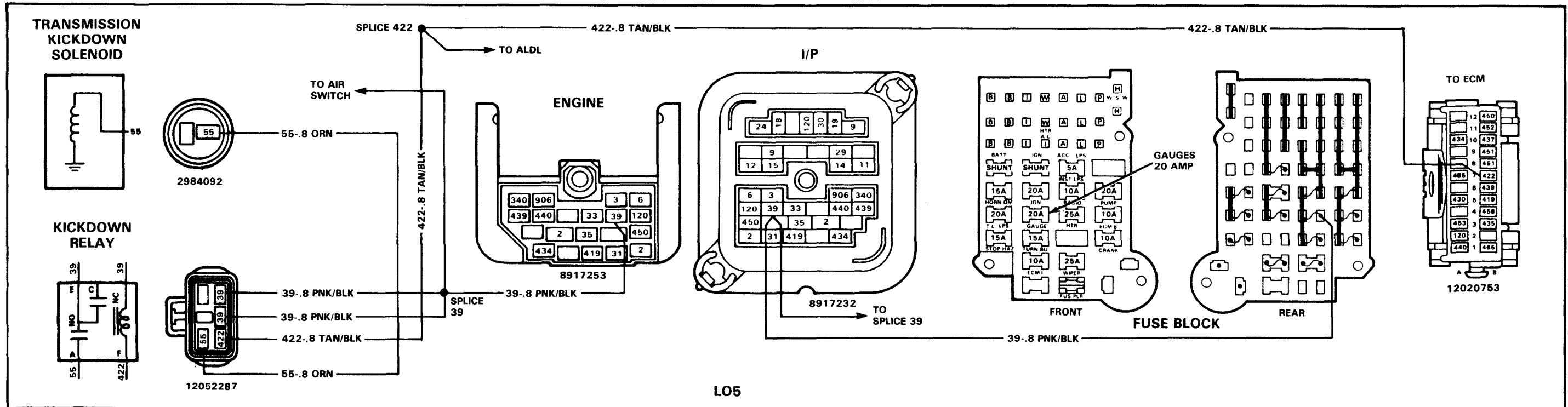

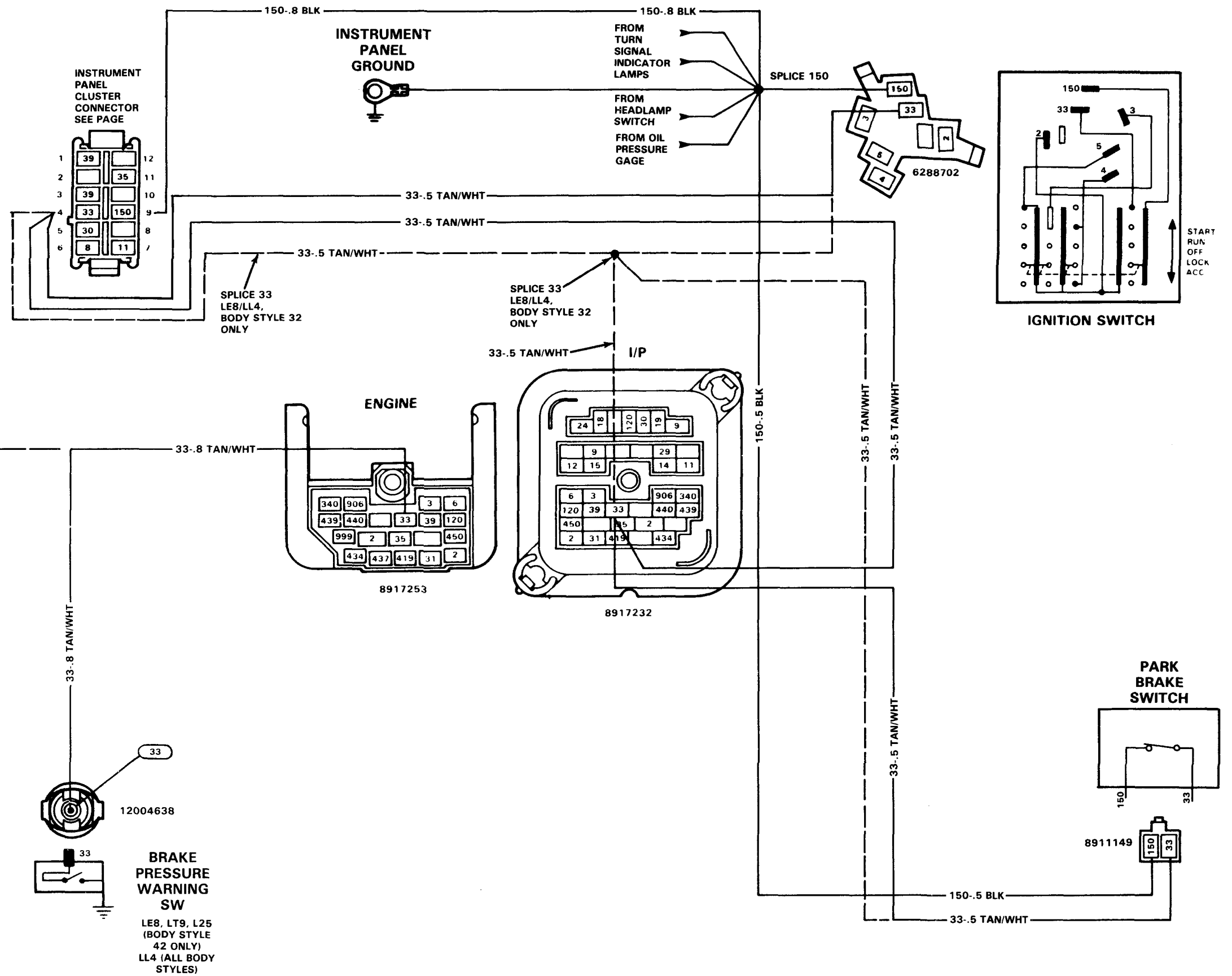

TRANSMISSION
DIAL LAMP
SOCKET
(LE8, LL4 ONLY)

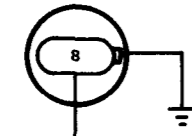

8-8 GRA

12004885

INST LPS
5 AMP

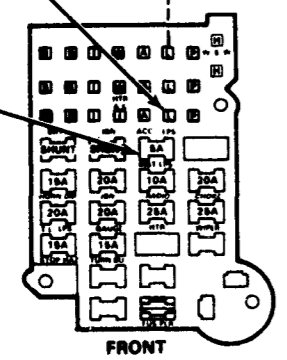

FRONT

FUSE BLOCK

WIPER/WASHER
SWITCH LAMP



8905381



SHEET
METAL
GROUND

8-5 GRA

150-8 BLK

150-8 BLK

150

94

91

92

91

92

94

8917310

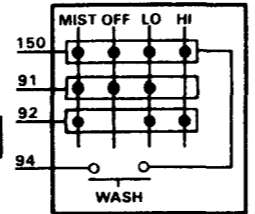

WINDSHIELD
WIPER
WASHER
SWITCH

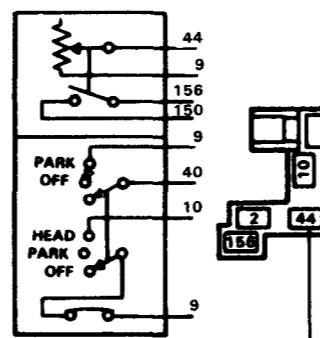

HEADLAMP
SWITCH

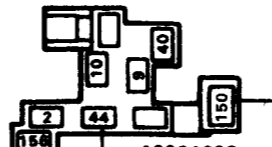

12004828

8-5 GRA

44-1.0 DK GRN

ILLUM

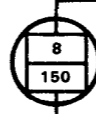

ILLUM

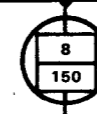

ILLUM



HIGH BEAM

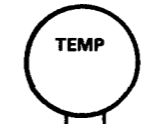
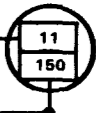

TEMP



FUEL

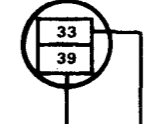

BRAKE

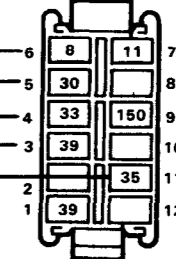

2984792

8-5 GRA

TURN SIG.
INDICATOR
LAMPS

OIL
GAGE

150-3.0 BLK

I/P
GROUND



150-3.0 BLK

IGNITION
SWITCH

PARKING
BRAKE SW

SPLICE
150

150-8 BLK

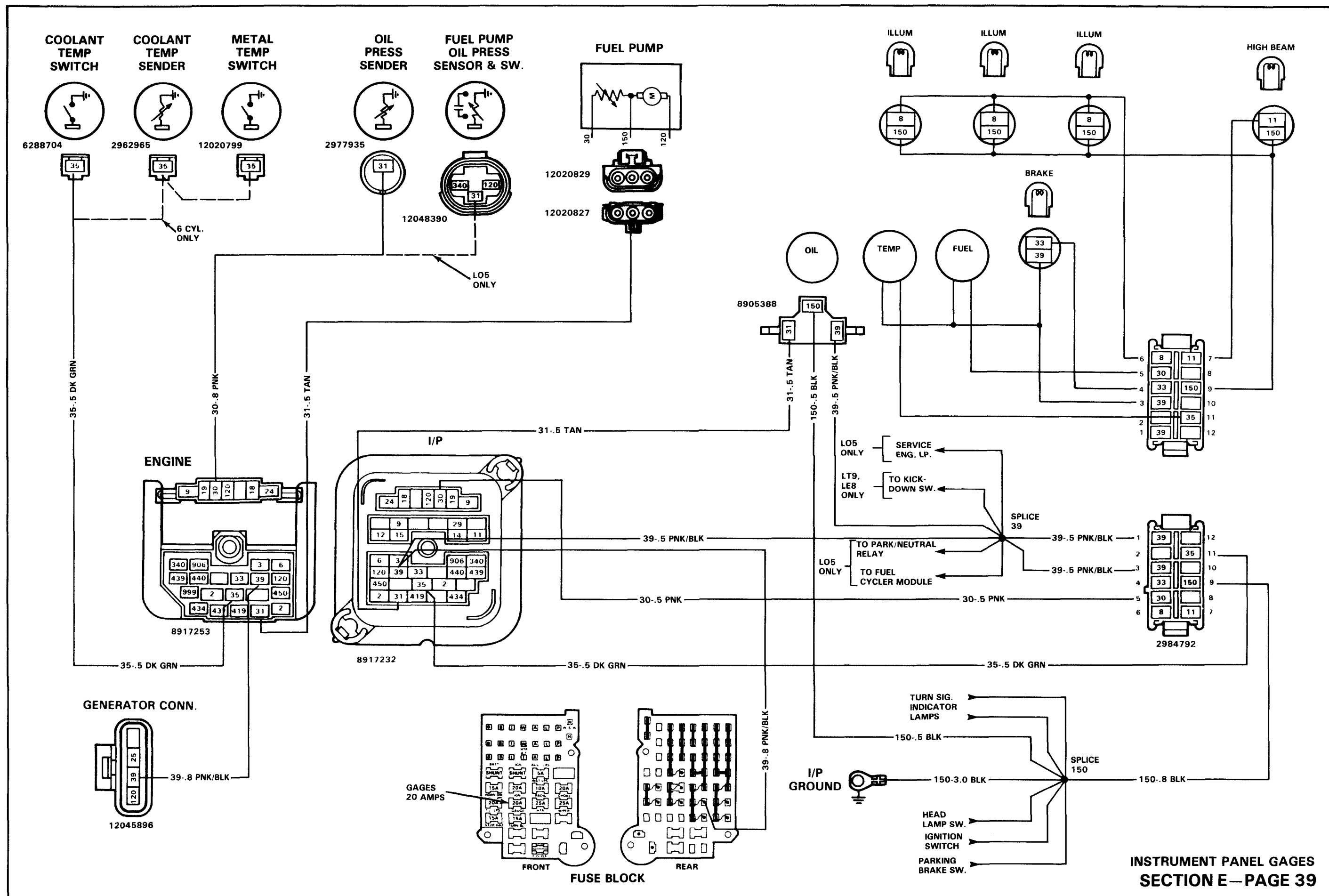

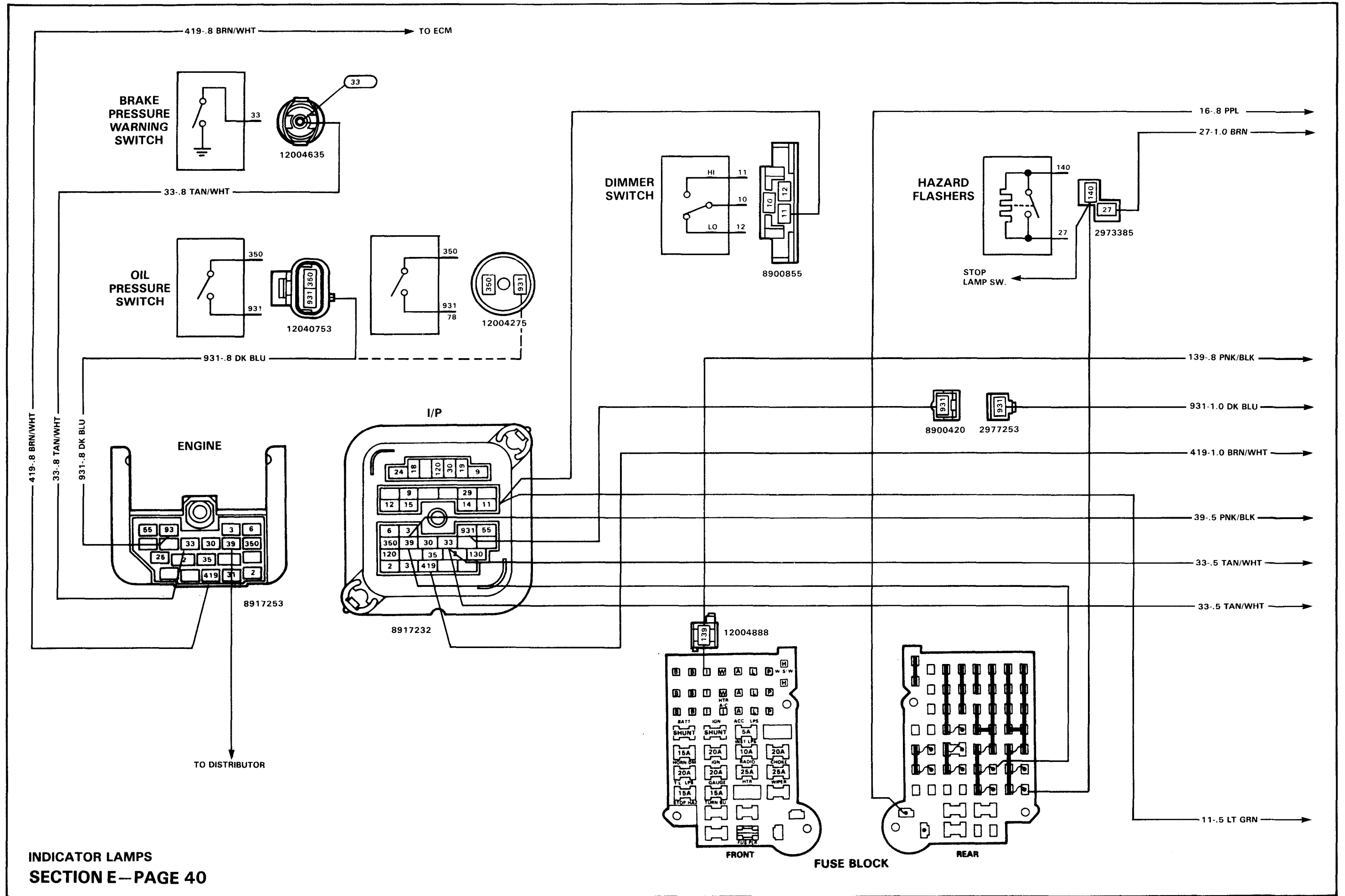

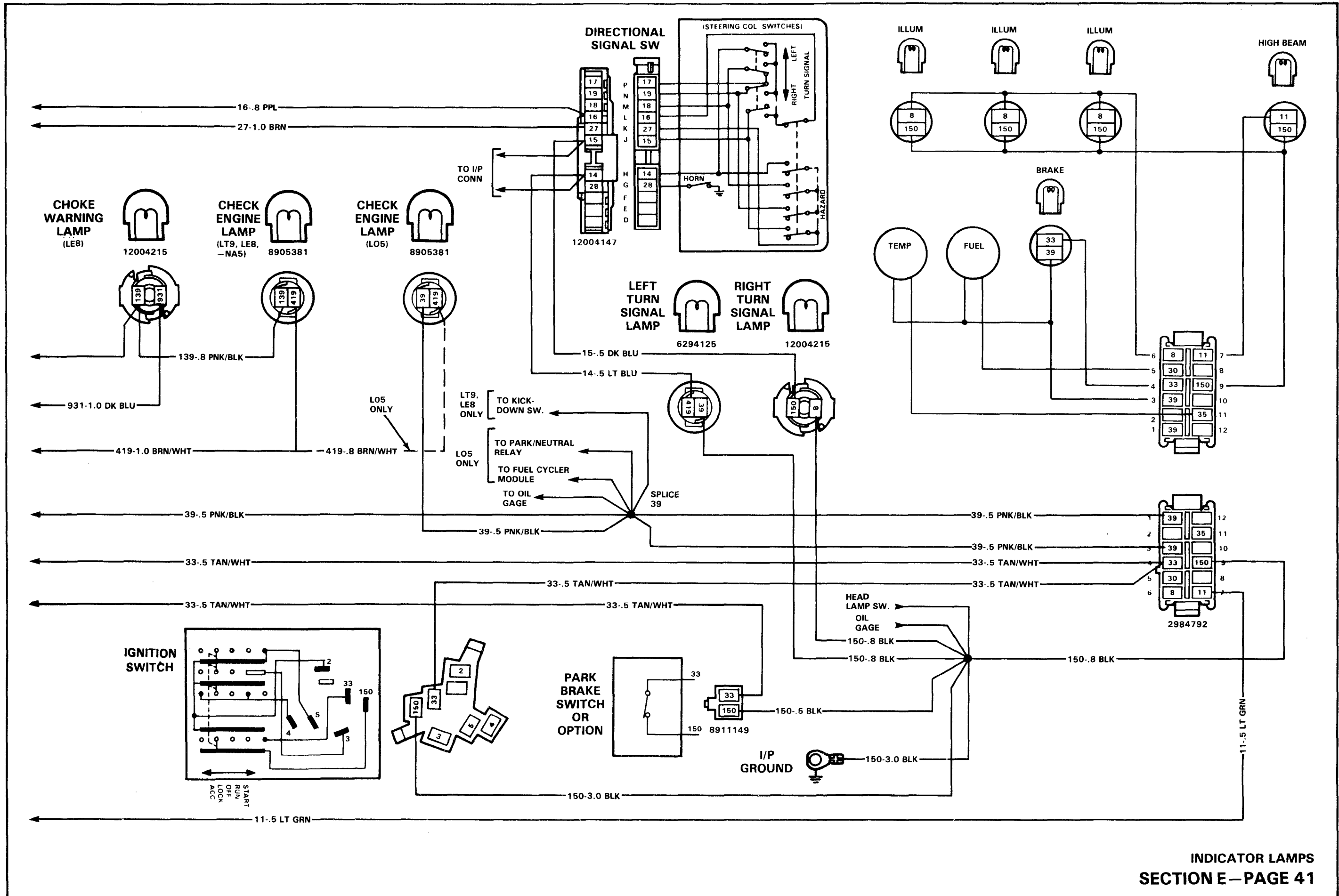

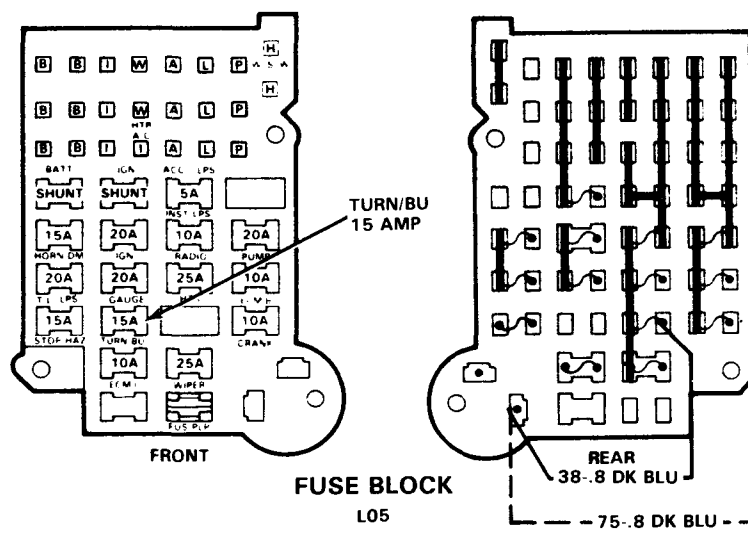
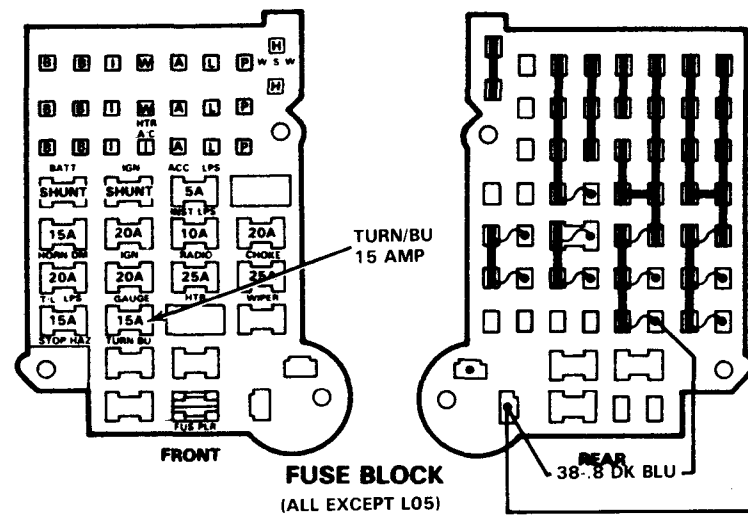

TRANSMISSION BACK-UP LAMP SWITCH
(AUTO TRANS ONLY)

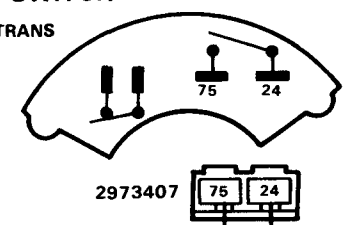

MANUAL TRANSMISSION ONLY



PROVISIONS FOR BACK-UP LP RIGHT HAND BACK-UP
(RPO E32/E33 ONLY)

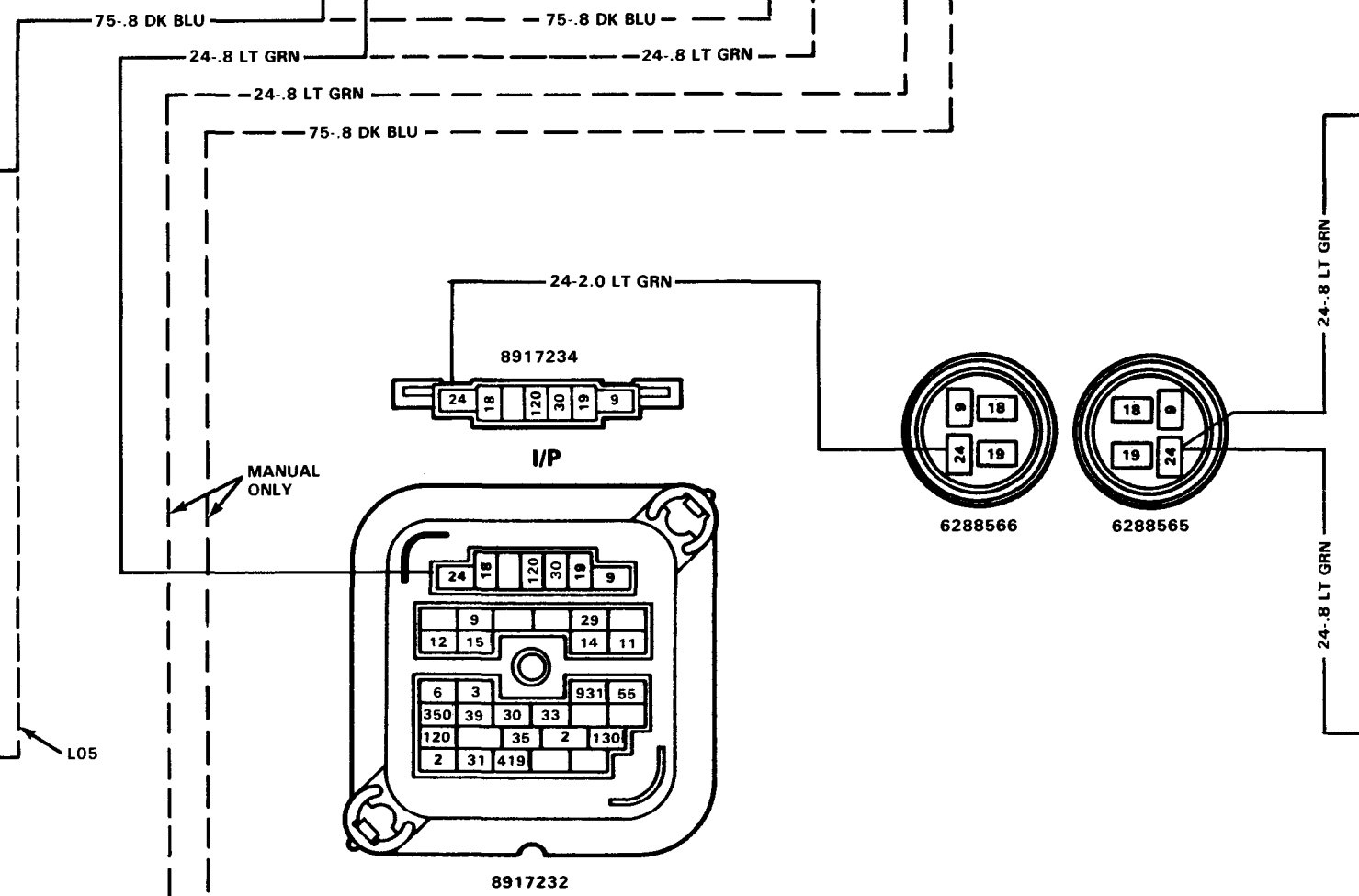
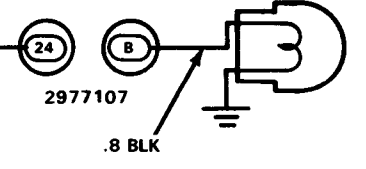

PROVISIONS FOR BACKUP LP LEFT HAND BACK-UP LAMP
(RPO E32/E33 ONLY)

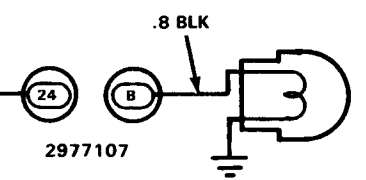

BACKUP LAMP SWITCH
4-SPEED MAN. ONLY

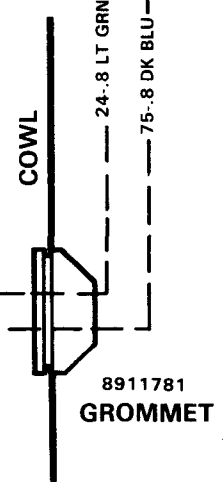
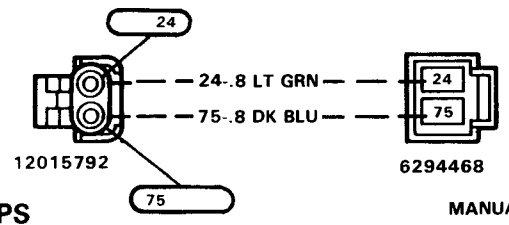
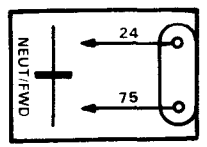

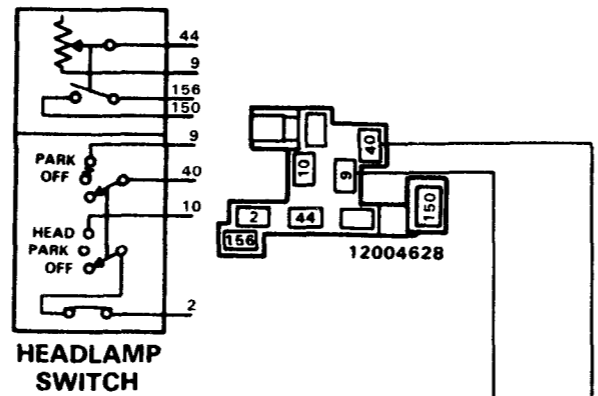

COWL

I/P

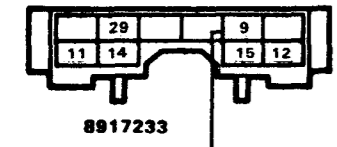
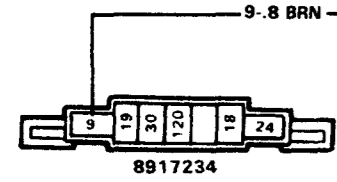

TO FORWARD LAMPS

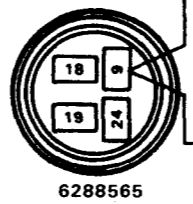
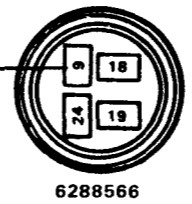
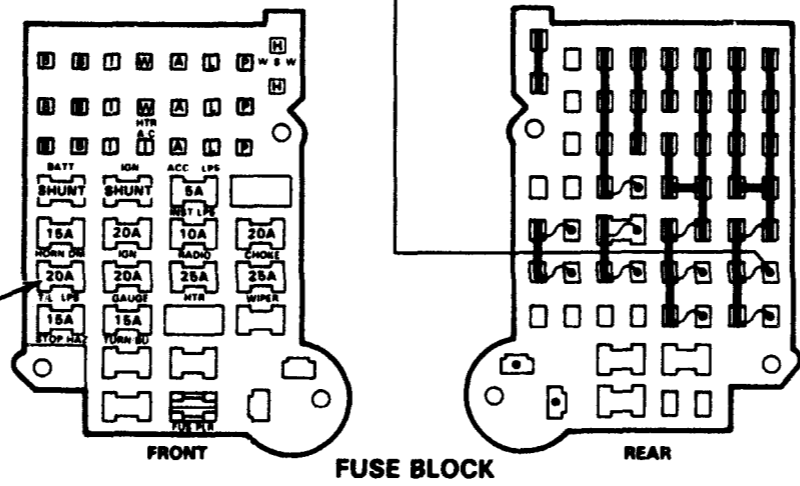
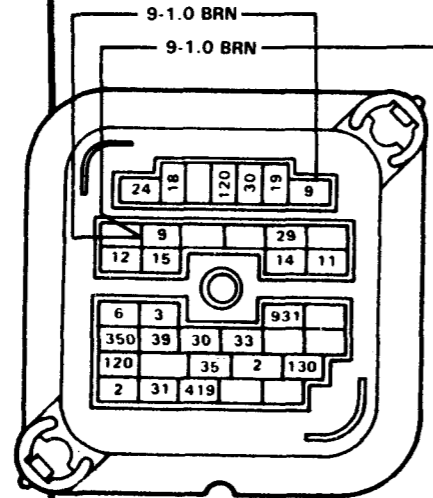

R.H. SIDE MARKER LAMP

PROVISIONS FOR R.H. TAIL, STOP & DIRECTIONAL LAMP (P32)

R.H. TAIL, STOP & DIRECTIONAL LAMP (P42)

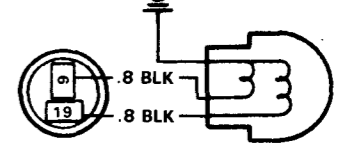

SPLICE 9

R.H. LICENSE LAMP

L.H. LICENSE LAMP

SPLICE 9

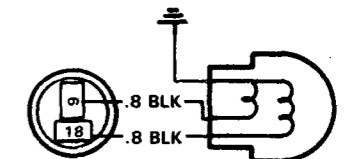

L.H. TAIL, STOP & DIRECTIONAL LAMP (P42)

PROVISIONS FOR L.H. TAIL, STOP & DIRECTIONAL LAMP (P32)

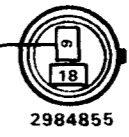

L.H. SIDE MARKER LAMP

1988 M VAN

SECTION F

<u>PAGE</u>	<u>DESCRIPTION</u>	<u>PAGE</u>	<u>DESCRIPTION</u>
2	POWER DISTRIBUTION	41	AUXILIARY HEATER (C36)
3	POWER DISTRIBUTION (ELECTRONIC CLUSTER ONLY)	42	BRAKE WARNING SYSTEM
4	FUSE BLOCK DETAIL	43	INSTRUMENT PANEL LAMPS (TELLTALE VERSION)
5	FUSE BLOCK DETAIL (ELECTRONIC CLUSTER ONLY)	44	INSTRUMENT PANEL LAMPS (GAGE VERSION)
6	HEAD LAMPS & PARKING LAMPS	45	INSTRUMENT PANEL LAMPS (ELECTRONIC CLUSTER)
7	MARKER LAMPS	46	INSTRUMENT PANEL GAGES (TELLTALE VERSION)
8	HAZARD LAMPS	48	INSTRUMENT PANEL GAGES (GAGE VERSION)
10	DIRECTIONAL LAMPS	50	INDICATOR LAMPS (TELLTALE VERSION)
12	FOG LAMPS (ANL)	52	INDICATOR LAMPS (GAGE VERSION)
13	HORNS	54	INDICATOR LAMPS (ELECTRONIC CLUSTER)
14	START (4 CYL.)	56	DOME LAMPS
15	START (6 CYL.)	57	LIGHTING PACKAGES—(C95) (DK6)
16	IGNITION (4 CYL.)	58	LIGHTING PACKAGE (TR9)
18	IGNITION (6 CYL.)	60	RADIO EQUIPMENT (STEREO) (UU9, UM7, UM6, UX1)
20	THROTTLE BODY INJECTION (4 CYL.)	61	RADIO EQUIPMENT (U63, U69)
21	THROTTLE BODY INJECTION (6 CYL.)	62	POWER WINDOWS (A31)
22	FUEL CONTROL & IDLE AIR CONTROL (LN8—4 CYL.)	63	POWER DOOR LOCKS (AU3)
23	FUEL CONTROL & IDLE AIR CONTROL (LB4—V6)	64	POWER SEAT (AC3)
24	ELECTRONIC CONTROL MODULE (ECM)—INPUTS (LN8—4 CYL.)	65	SEAT BELT WARNING BUZZER
26	ELECTRONIC CONTROL MODULE (ECM)—OUTPUTS (LN8—4 CYL.)	66	POWER MIRRORS (D48)
29	ECM CHART (LN8—4 CYL.)	67	VANITY MIRROR (D64)
30	ELECTRONIC CONTROL MODULE (ECM)—INPUTS (LB4—V6)	68	WIPER/WASHER
32	ELECTRONIC CONTROL MODULE (ECM)—OUTPUTS (LB4—V6)	69	PULSE WIPER/WASHER (CD4)
35	ECM CHART (LB4—V6)	70	CRUISE CONTROL (K34)
36	TRANSMISSION CONVERTER CLUTCH DETENT SOLENOID	71	BACK-UP LAMPS
37	REAR AIR CONDITIONING (C69)	72	TAIL LAMPS
38	AIR CONDITIONING (LN8—4 CYL.)	73	LICENSE LAMP
39	AIR CONDITIONING (LB4—V6)	74	TRAILER WIRING (UY7)
40	HEATER		

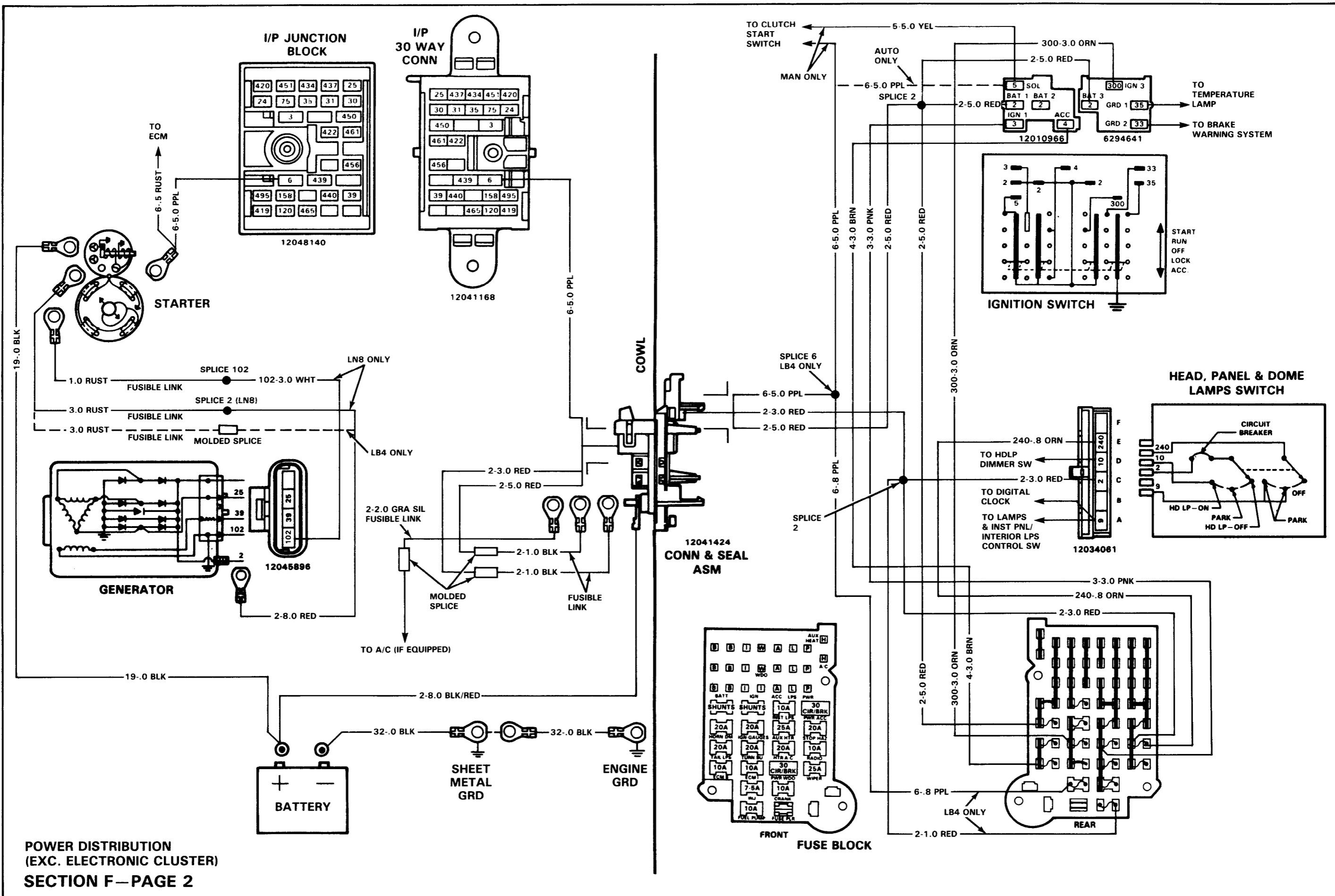

POWER DISTRIBUTION
(EXC. ELECTRONIC CLUSTER)
SECTION F—PAGE 2

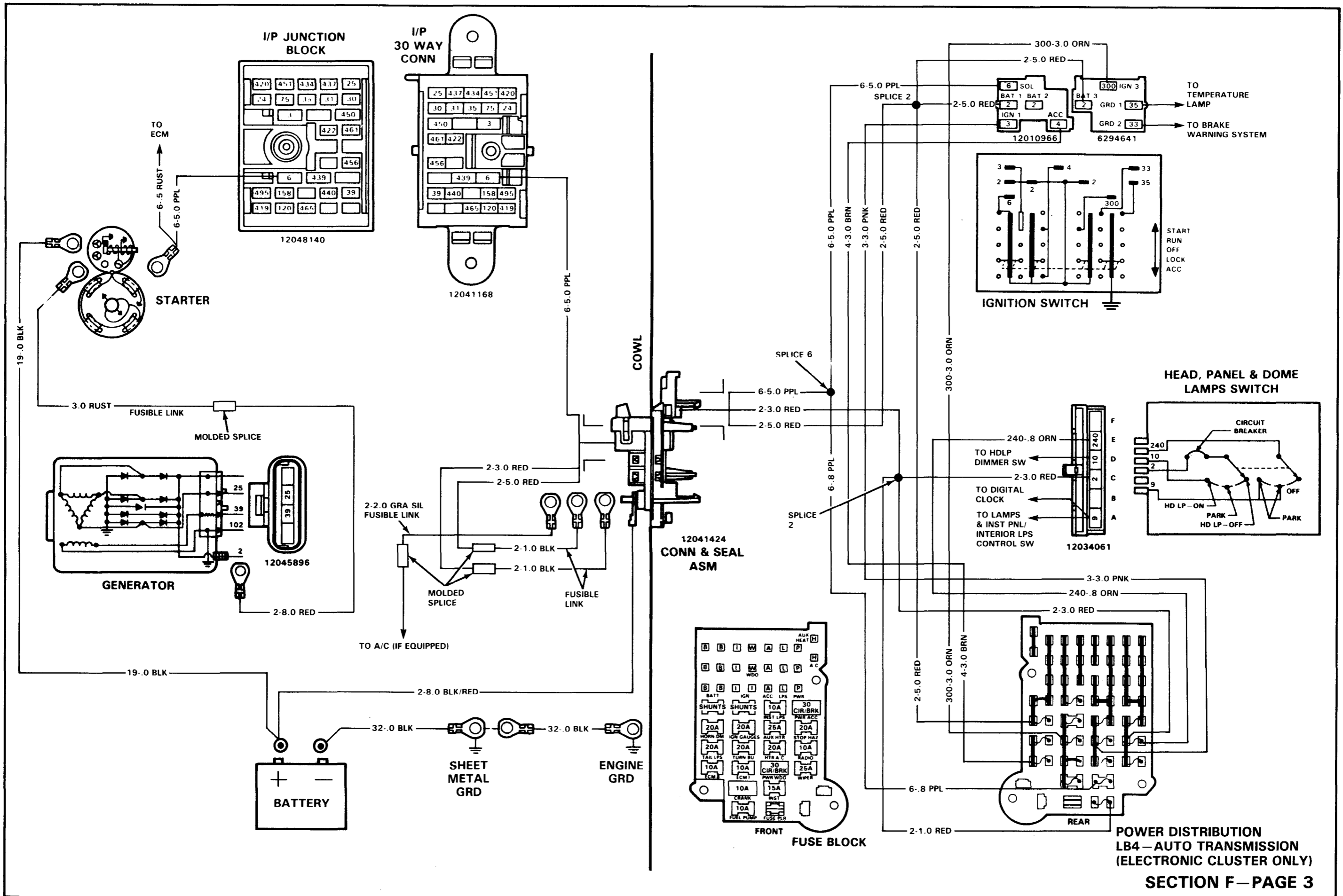

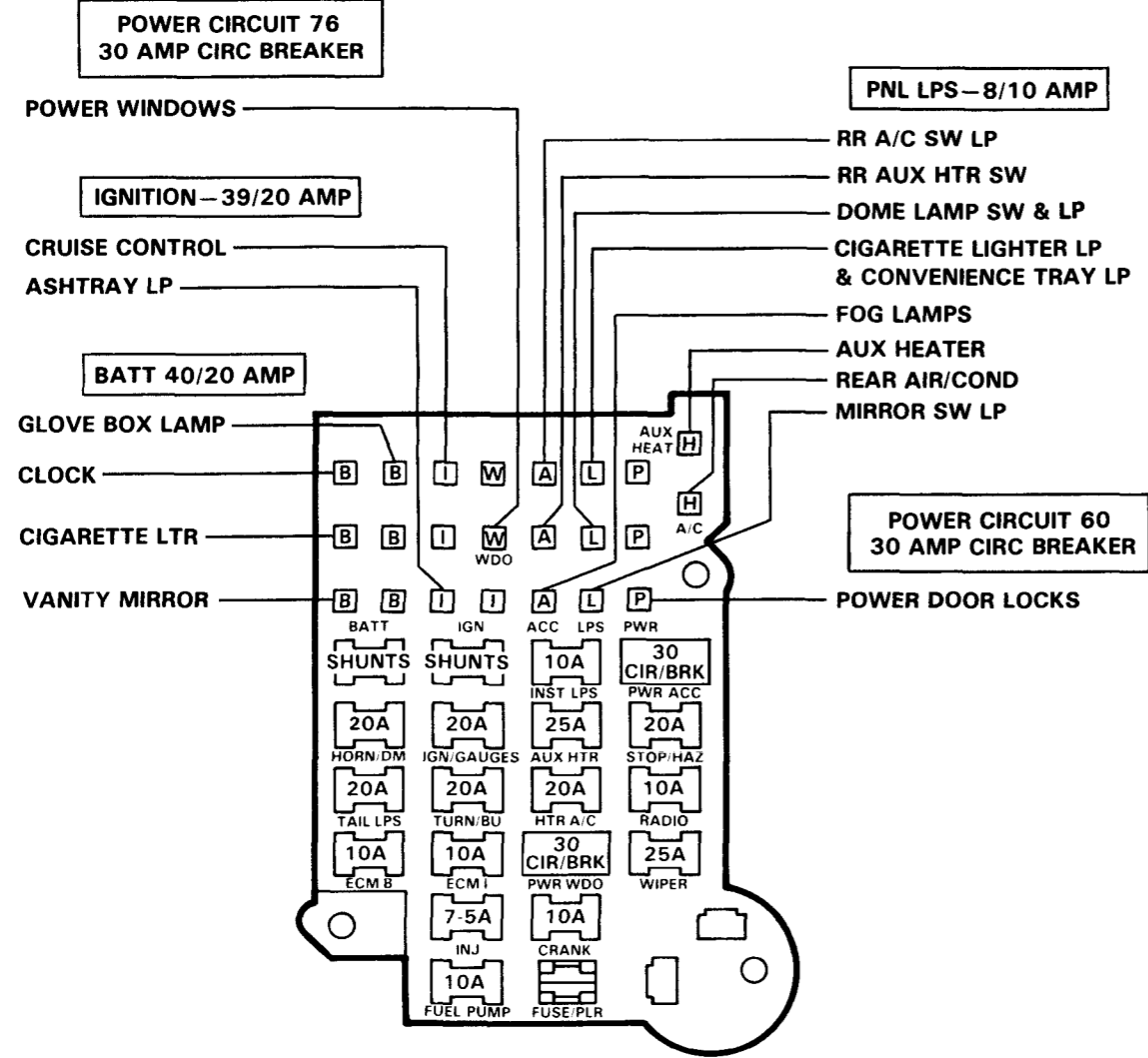

FRONT
12034359 BLOCK-MOLD
PRINTED BLOCK

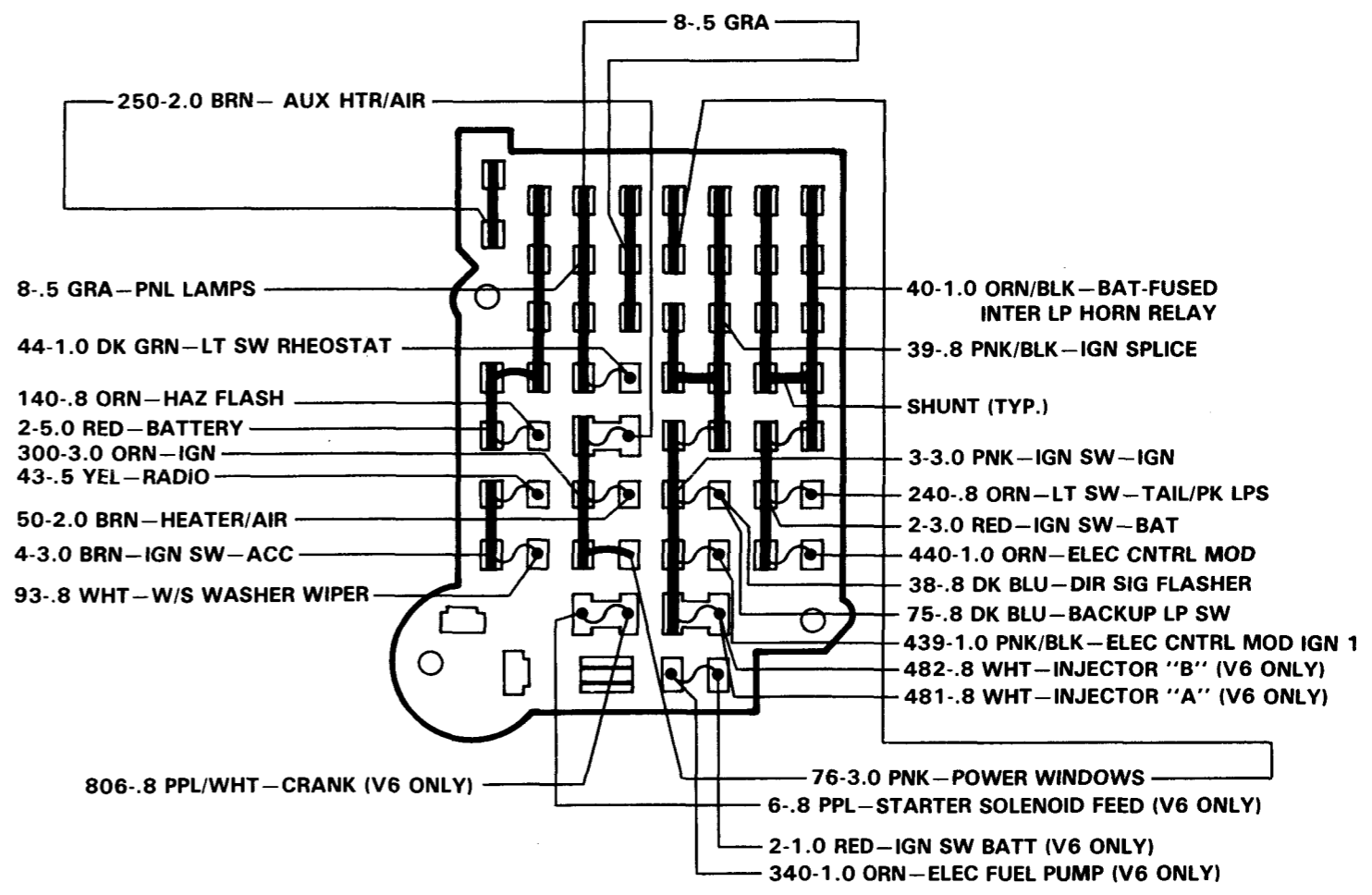

REAR

	COLOR	MALE CONN	MULT CONN
I	NAT	12004888	12004892
A	BRN	12004887	12004893
B	BLK	12004886	12004890
L	GRN	12004885	12004962
P	RED	12004883	12004889
W	BLU	12004884	
H	DK GRA	12004740	12004891
	ORN	12004018	

FUSES	AMP	COLOR
12004005	5	TAN
12004007	10	RED
12004008	15	LT BLU
12004009	20	YEL
12004010	25	WHT
12004003	3	VIOLET
12004006	7.5	BROWN
12004011	30	LT GRN

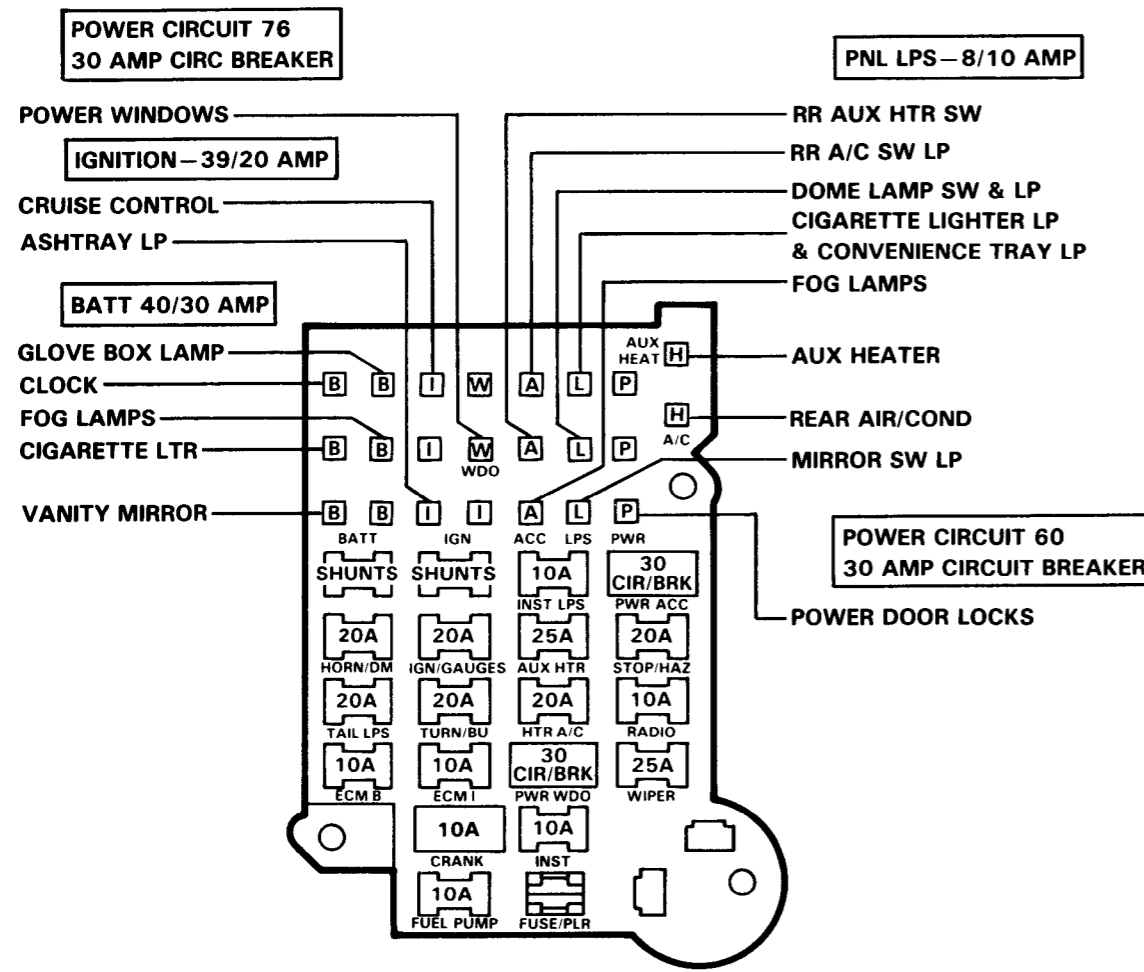

FRONT
12065941 BLOCK-MOLD
PRINTED BLOCK

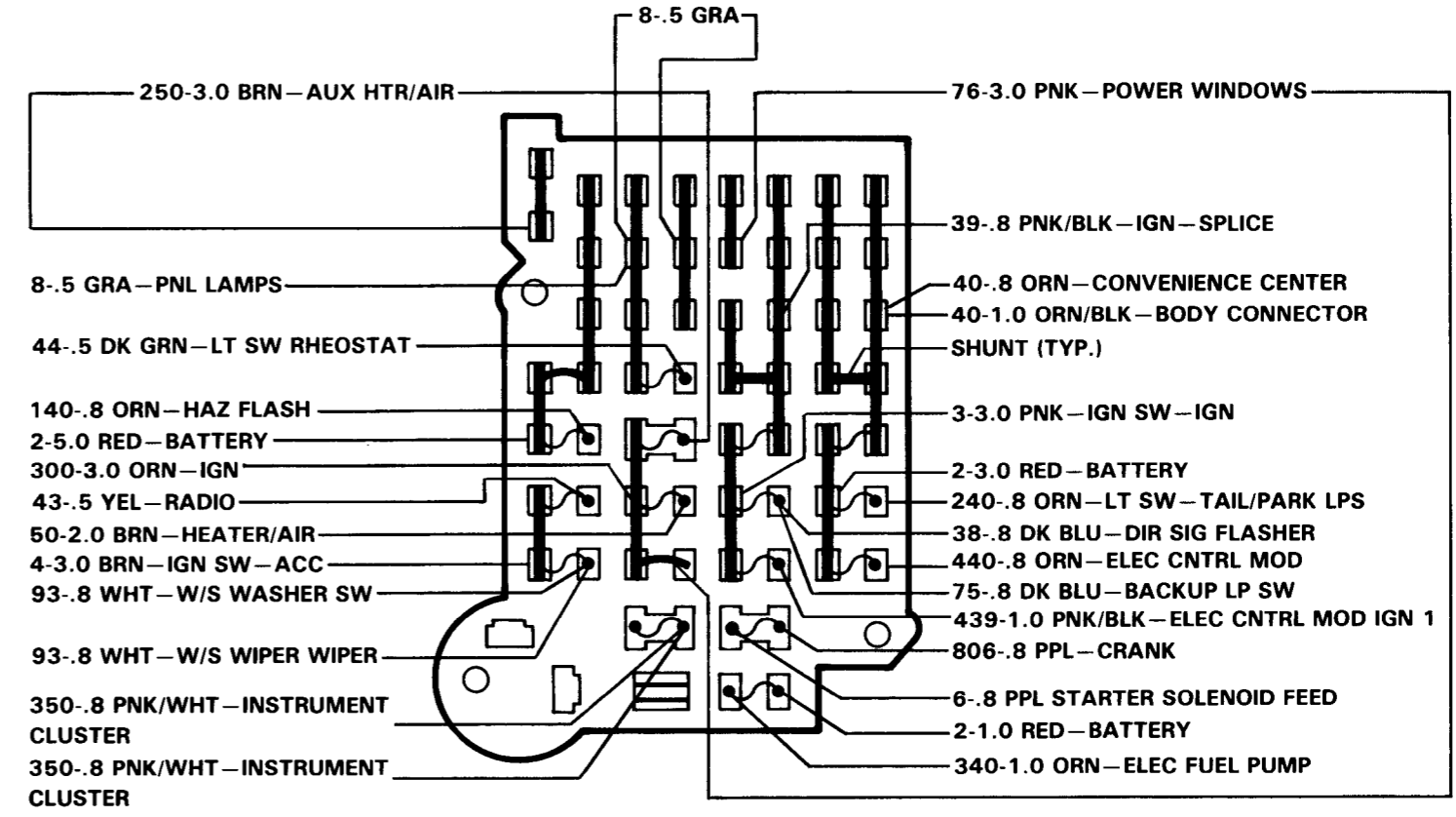

REAR

	COLOR	MALE CONN	MULT CONN
I	NAT	12004888	12004892
A	BRN	12004887	12004893
B	BLK	12004886	12004890
L	GRN	12004885	12004962
P	RED	12004883	12004889
W	BLU	12004884	
H	DK GRA	12004740	12004891
	ORN	12004018	

FUSES	AMP	COLOR
12004005	5	TAN
12004007	10	RED
12004008	15	LT BLU
12004009	20	YEL
12004010	25	WHT
12004003	3	VIOLET
12004006	7.5	BROWN
12004011	30	LT GRN

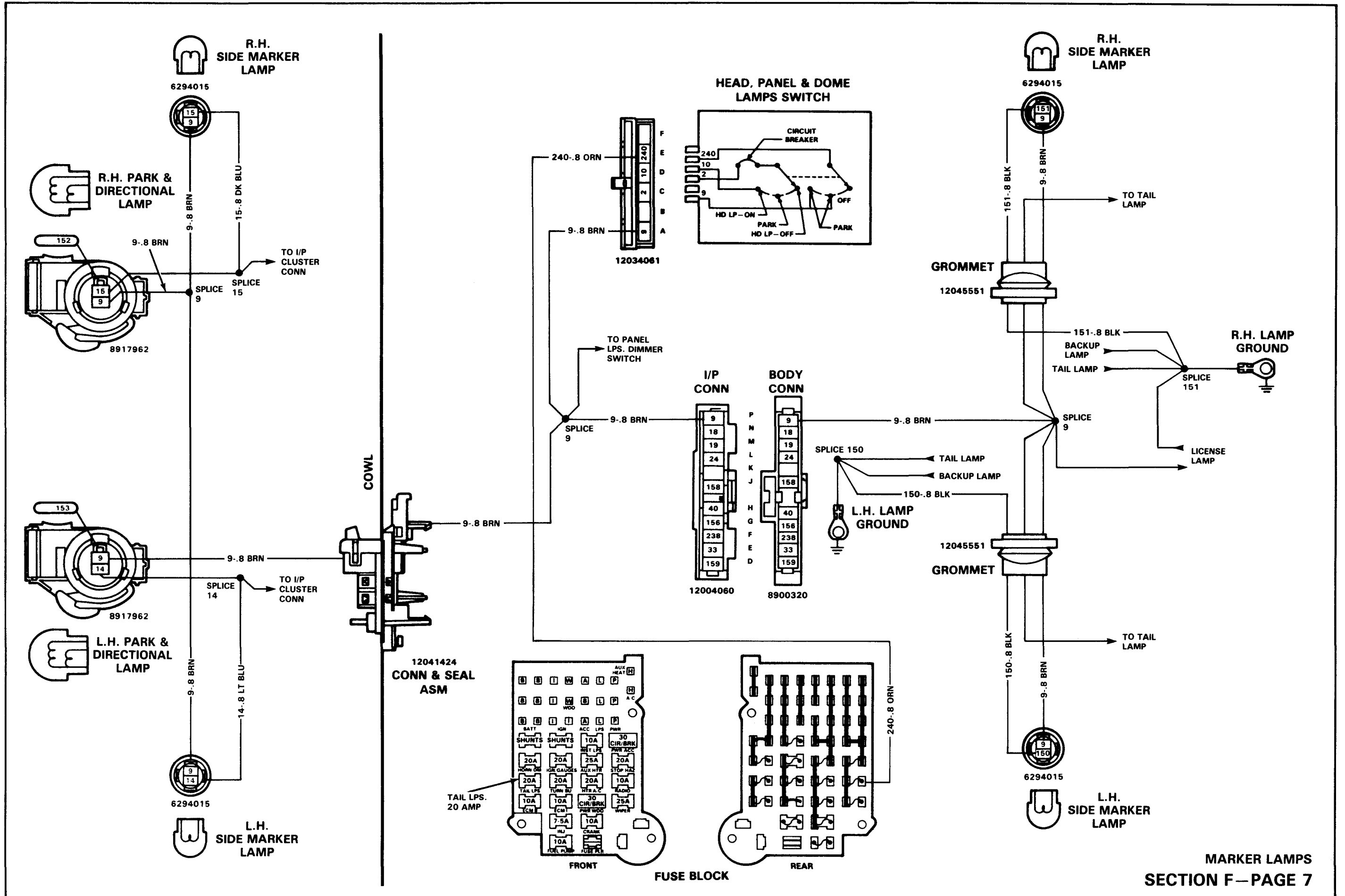

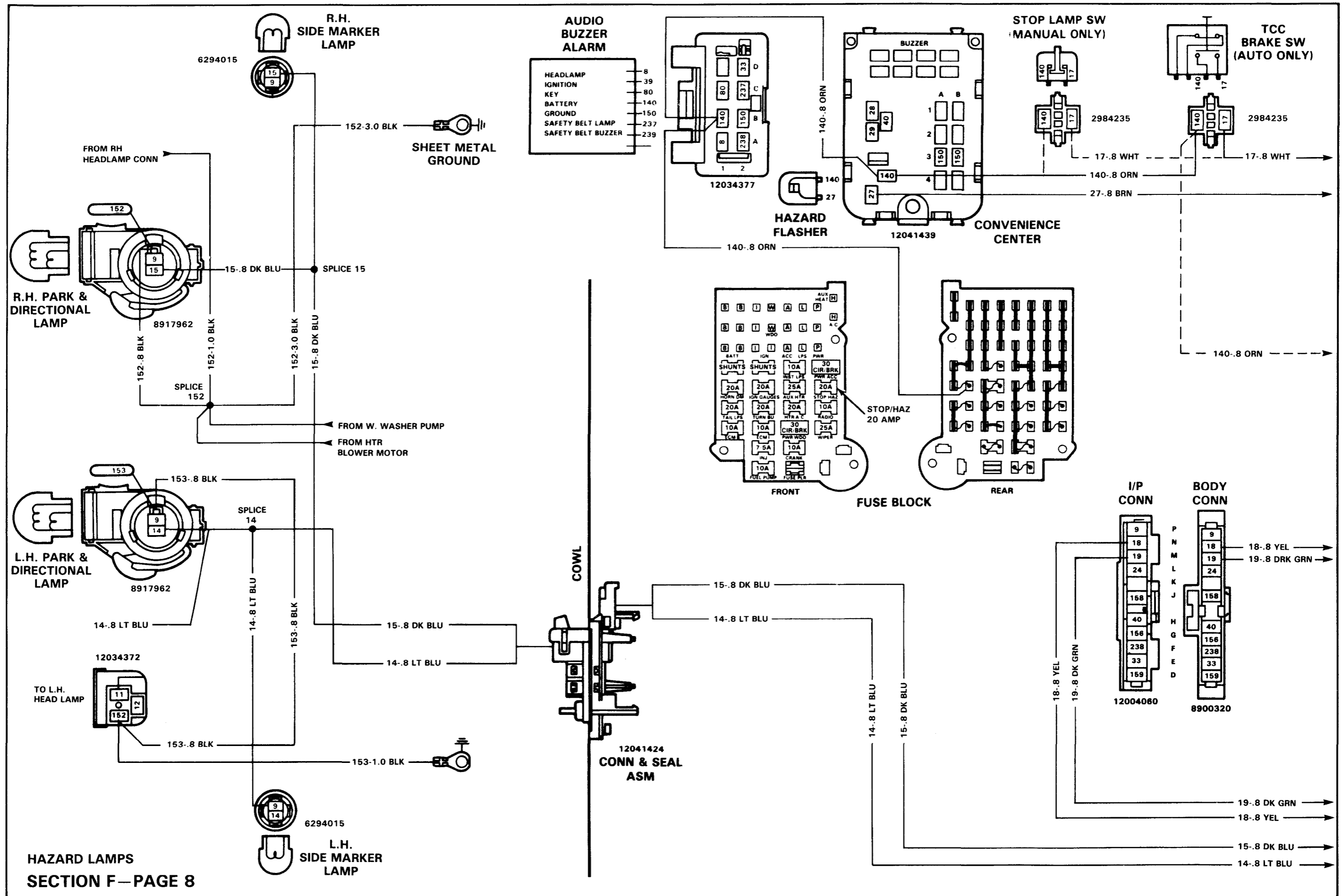

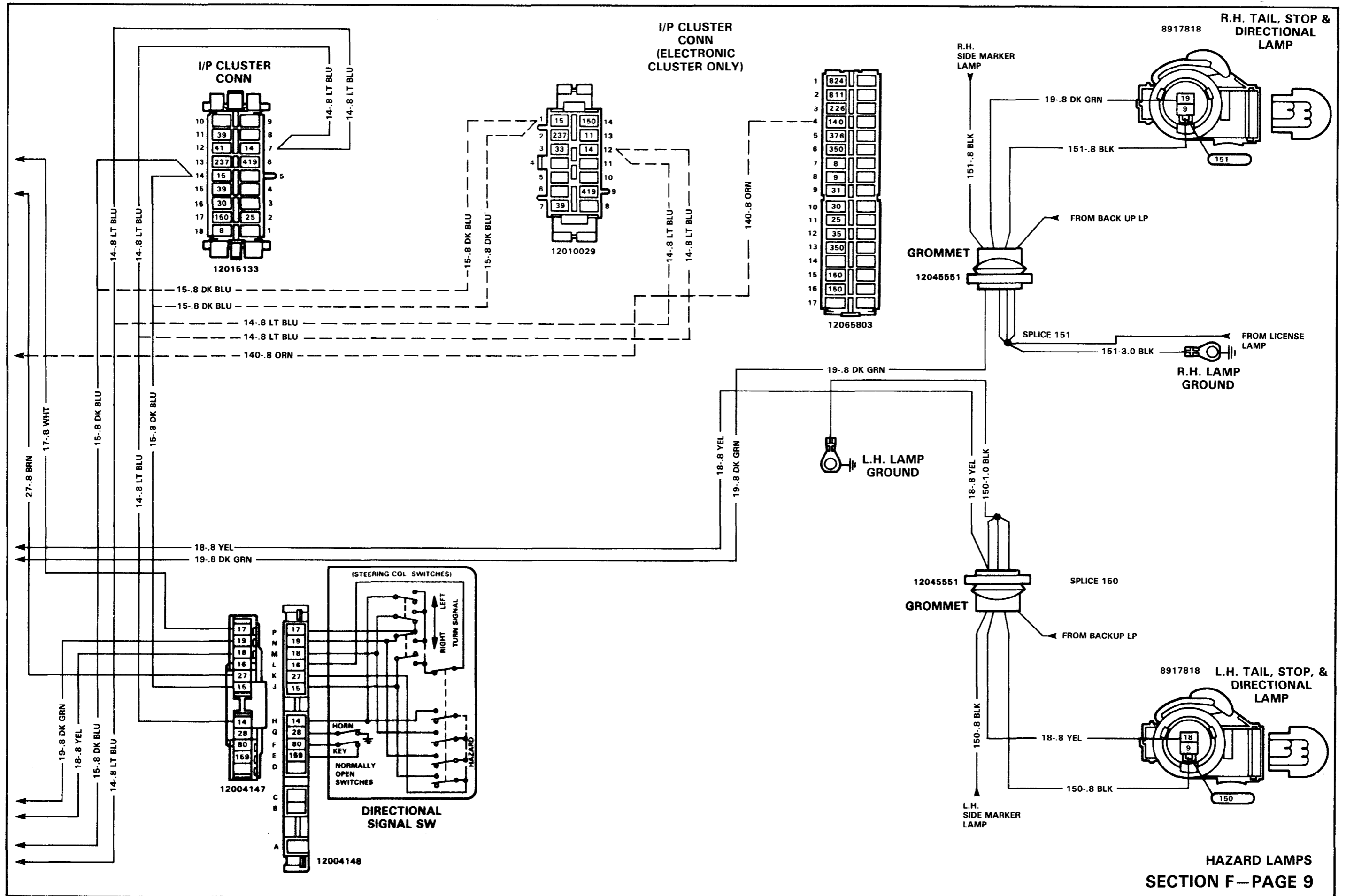

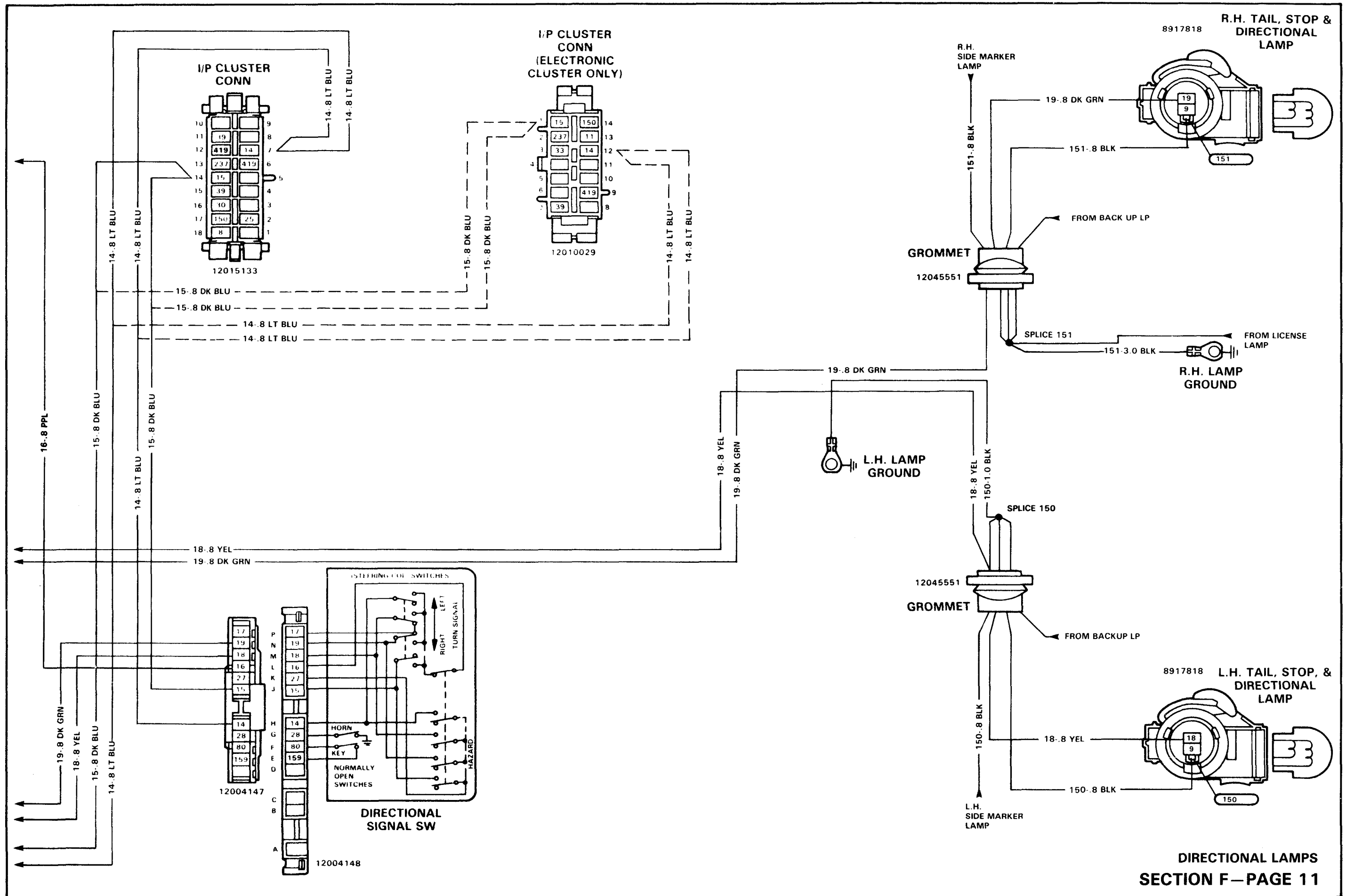

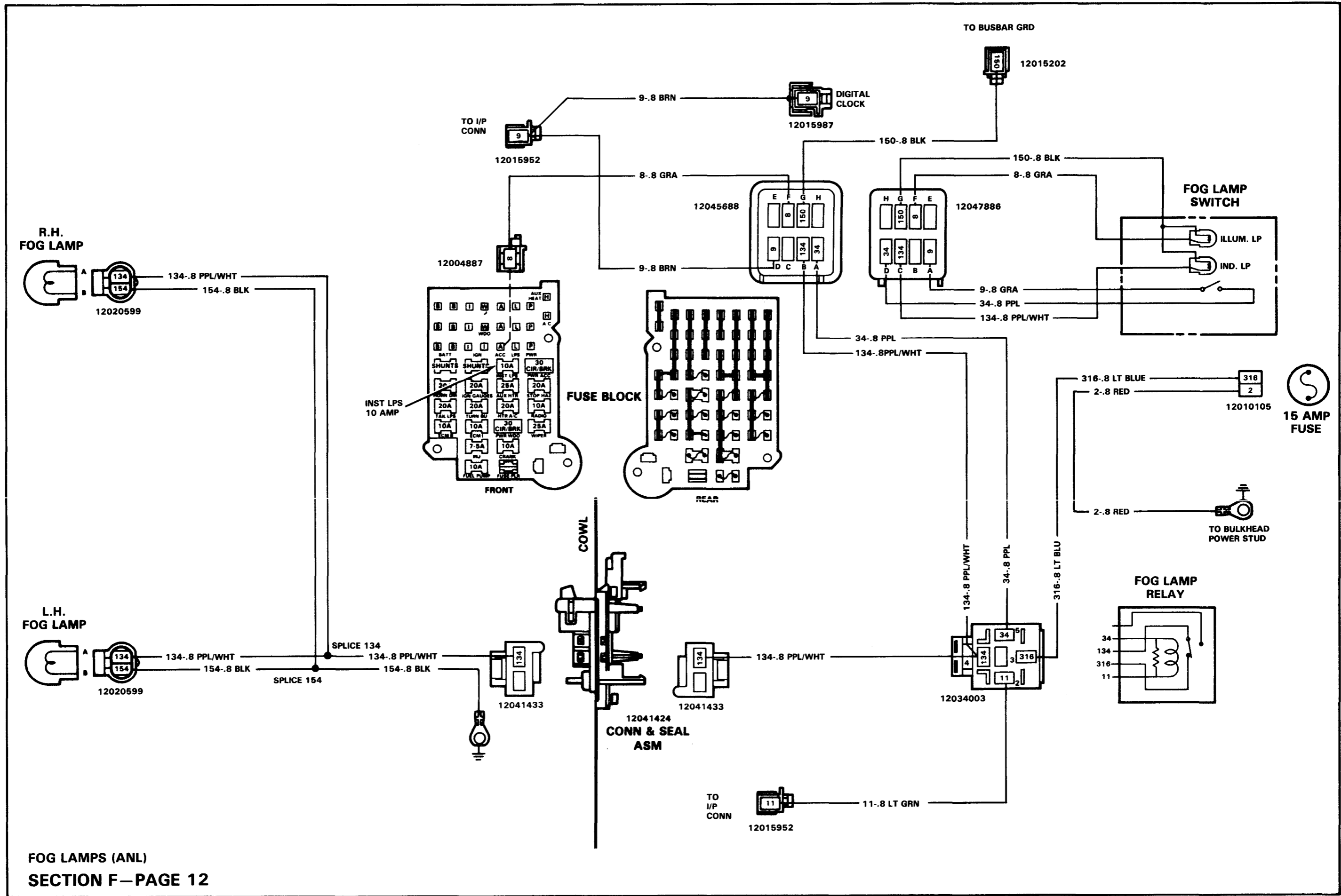

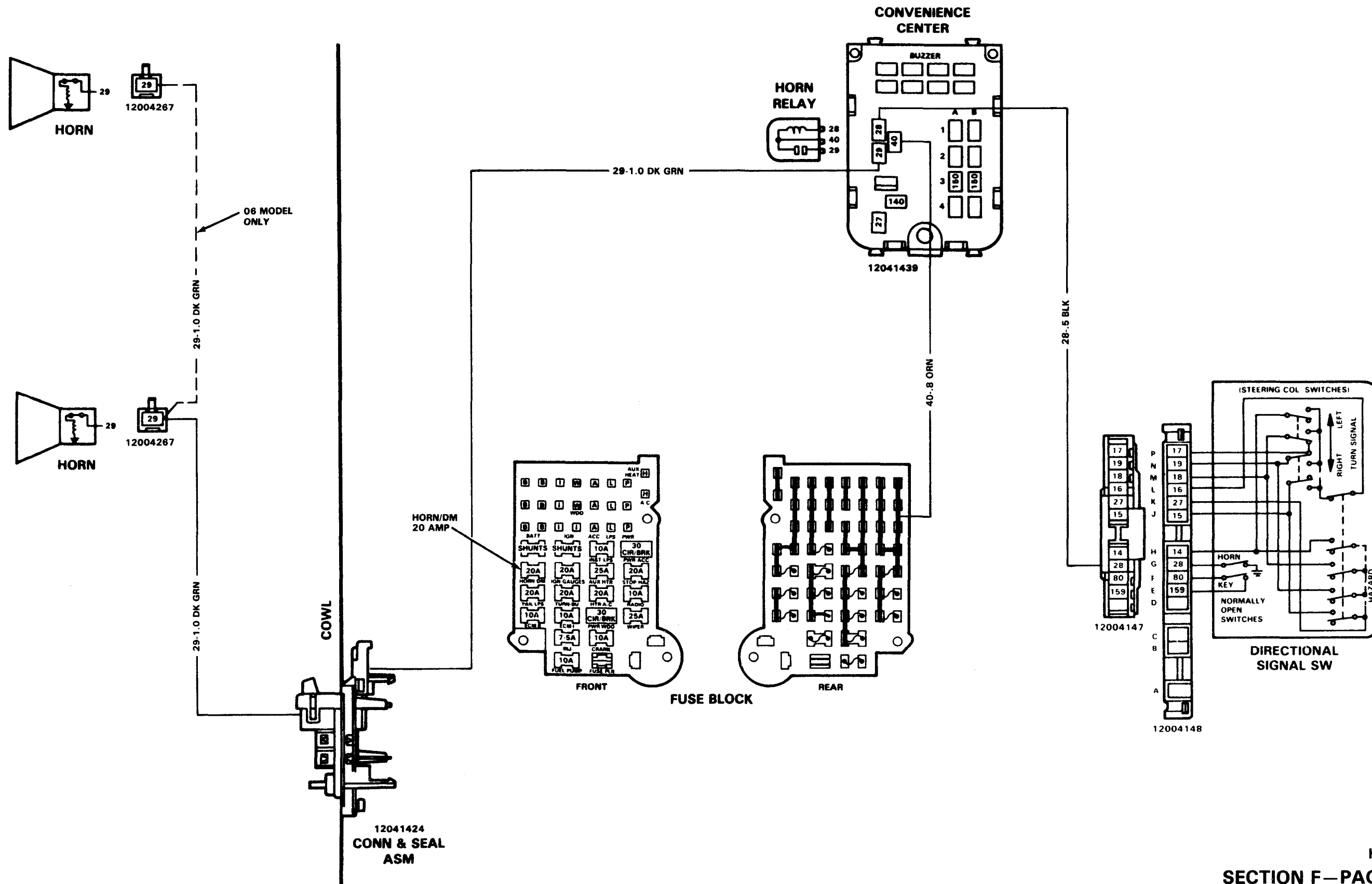

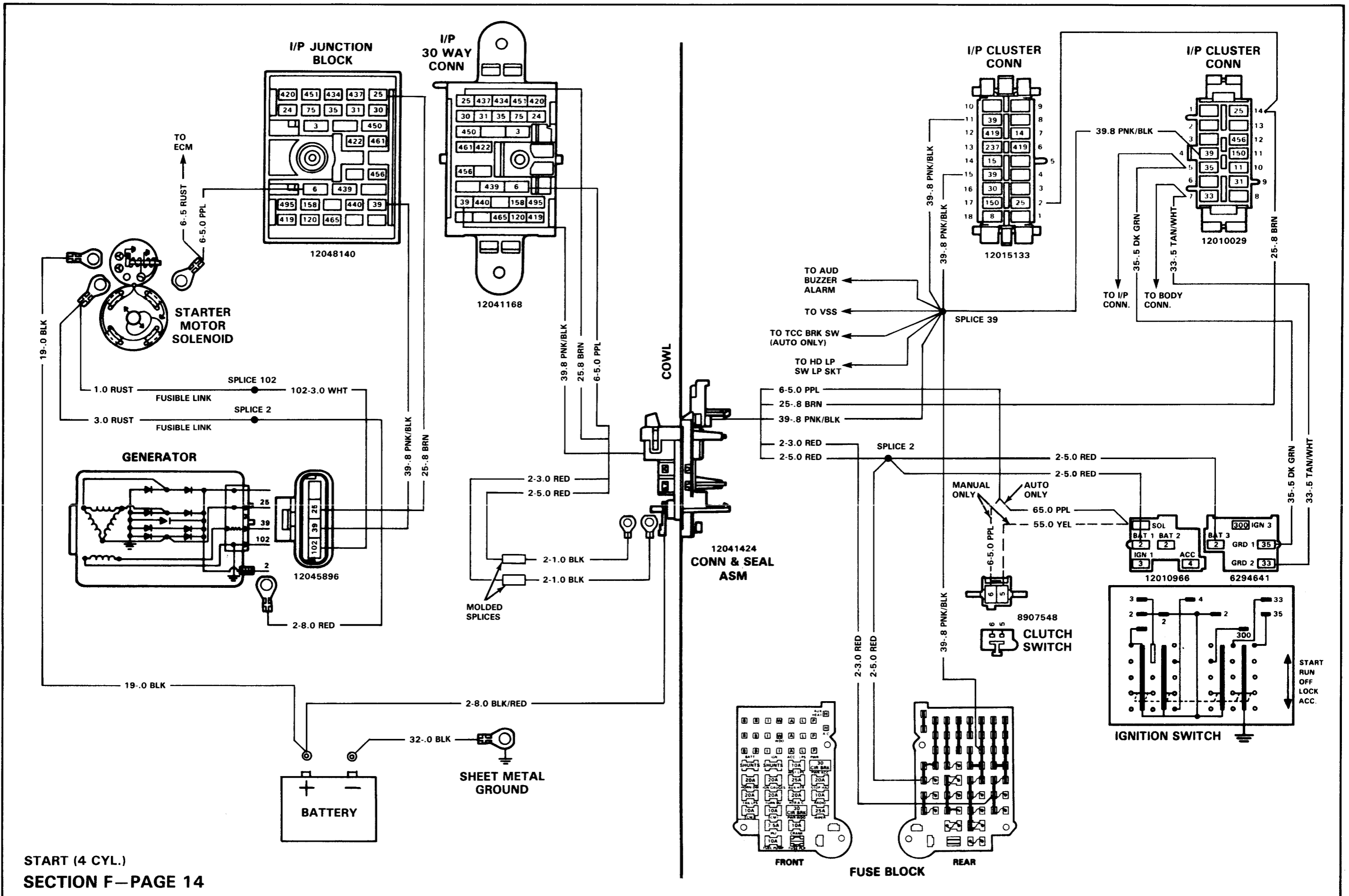

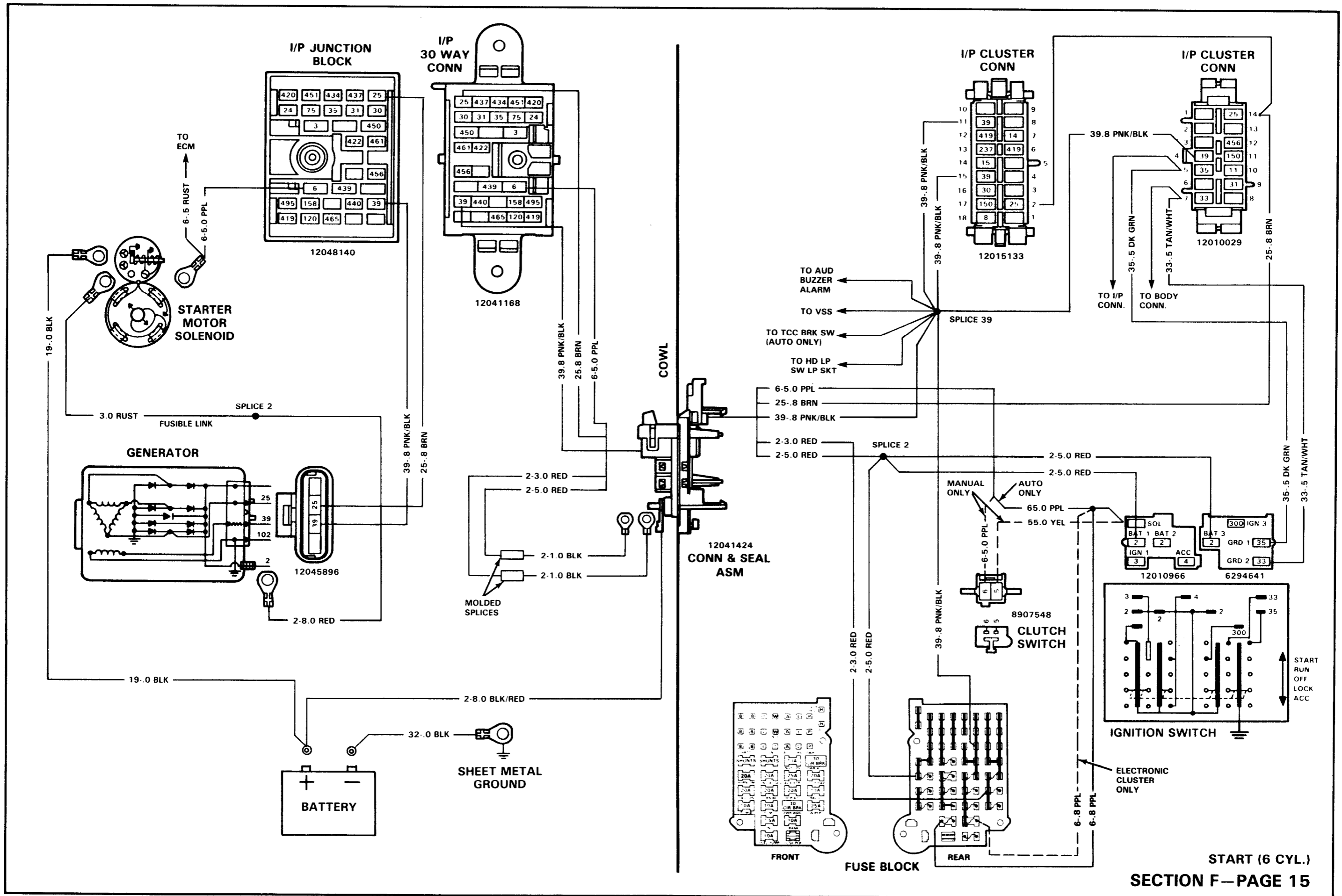

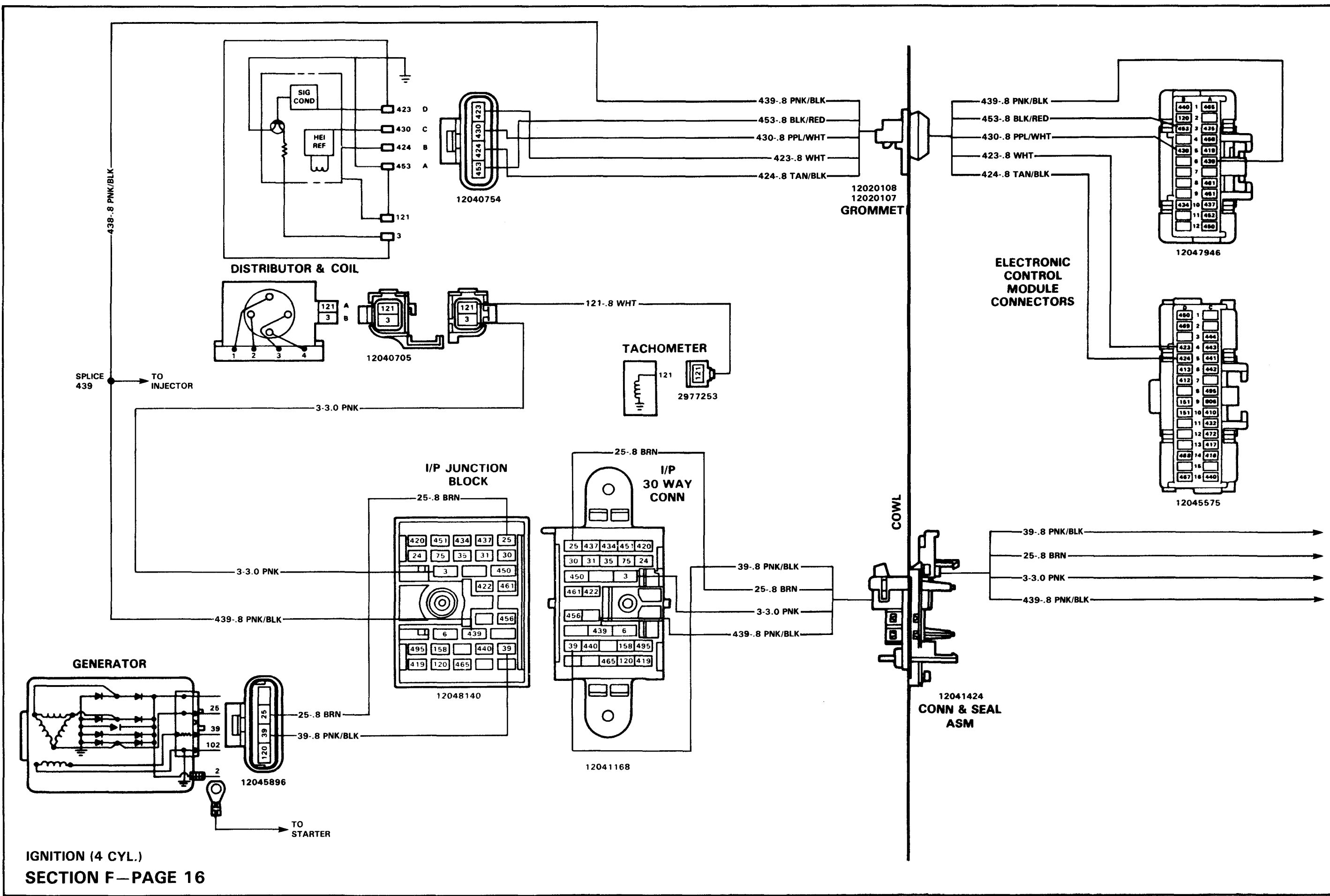

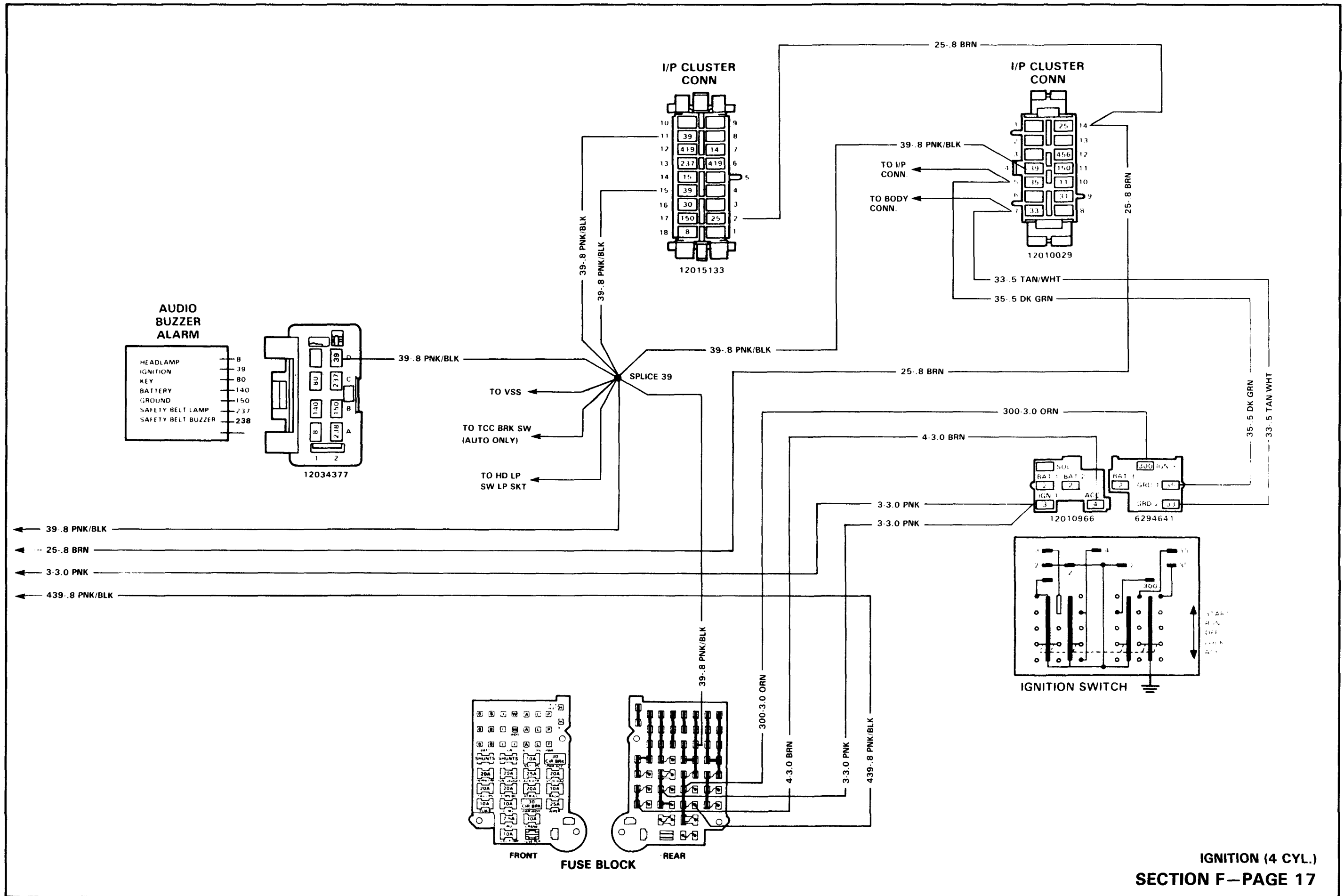

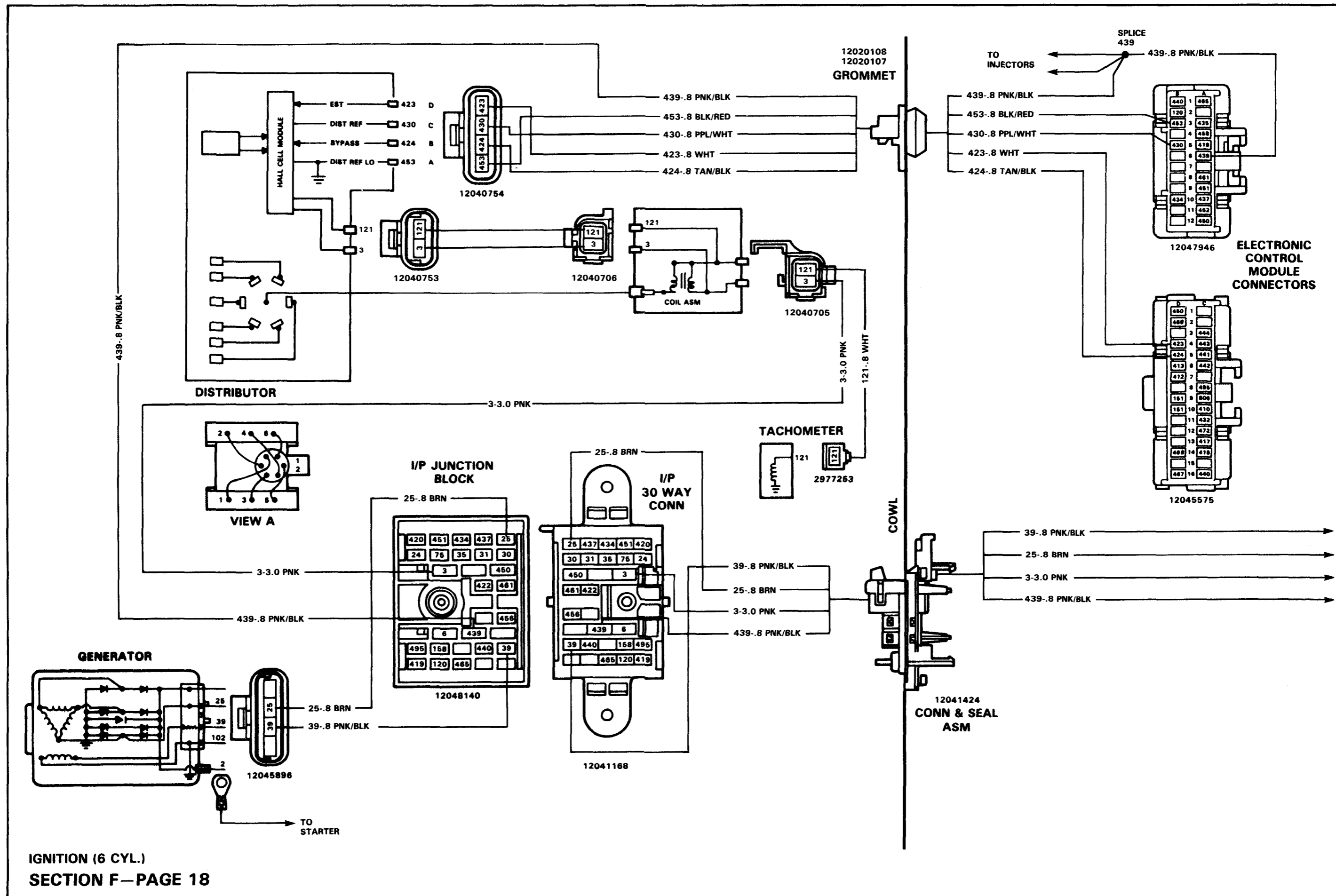

SPLICE
439

12020108
12020107
GROMMET

TO
INJECTORS

439-.8 PNK/BLK

439-.8 PNK/BLK
453-.8 BLK/RED
430-.8 PPL/WHT
423-.8 WHT
424-.8 TAN/BLK

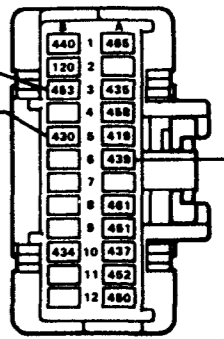

12047946

ELECTRONIC
CONTROL
MODULE
CONNECTORS

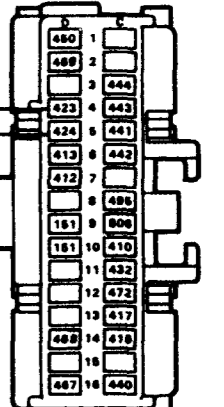

12045575

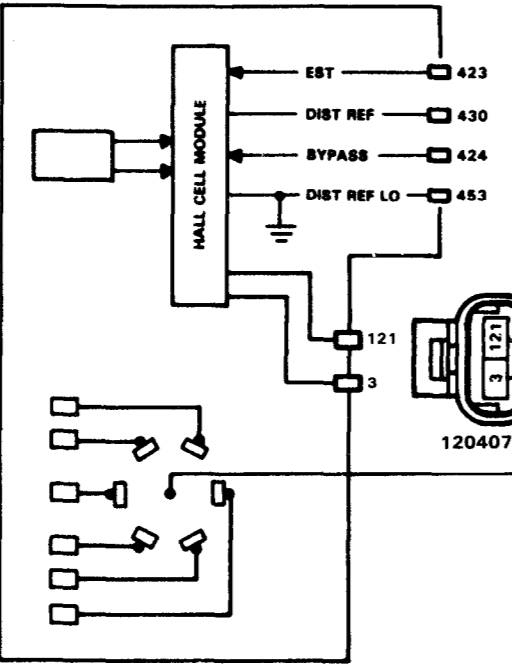

DISTRIBUTOR

12040754



12040753

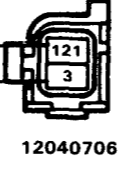

12040706

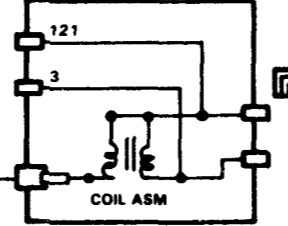

12040705

3-3.0 PNK

3-3.0 PNK

121-.8 WHT

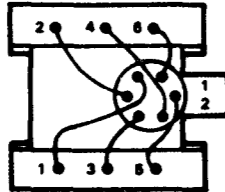

VIEW A

I/P JUNCTION
BLOCK

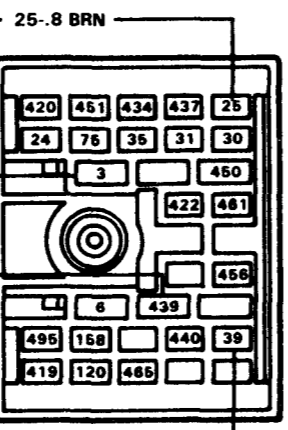

12048140

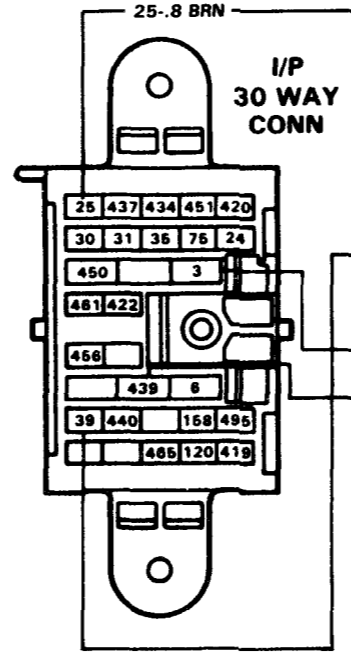

12041168

TACHOMETER

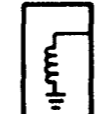

2977263

COWL

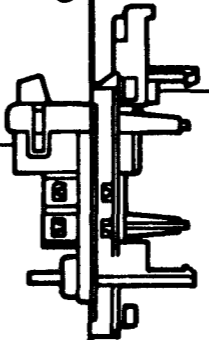

12041424
CONN & SEAL
ASM

39-.8 PNK/BLK
25-.8 BRN
3-3.0 PNK
439-.8 PNK/BLK

439-.8 PNK/BLK

GENERATOR

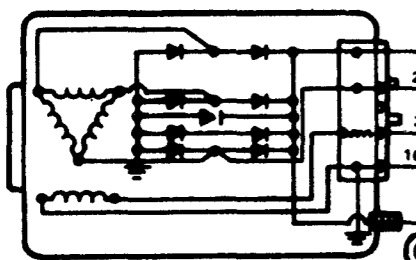

12045896

25-.8 BRN
39-.8 PNK/BLK

TO
STARTER

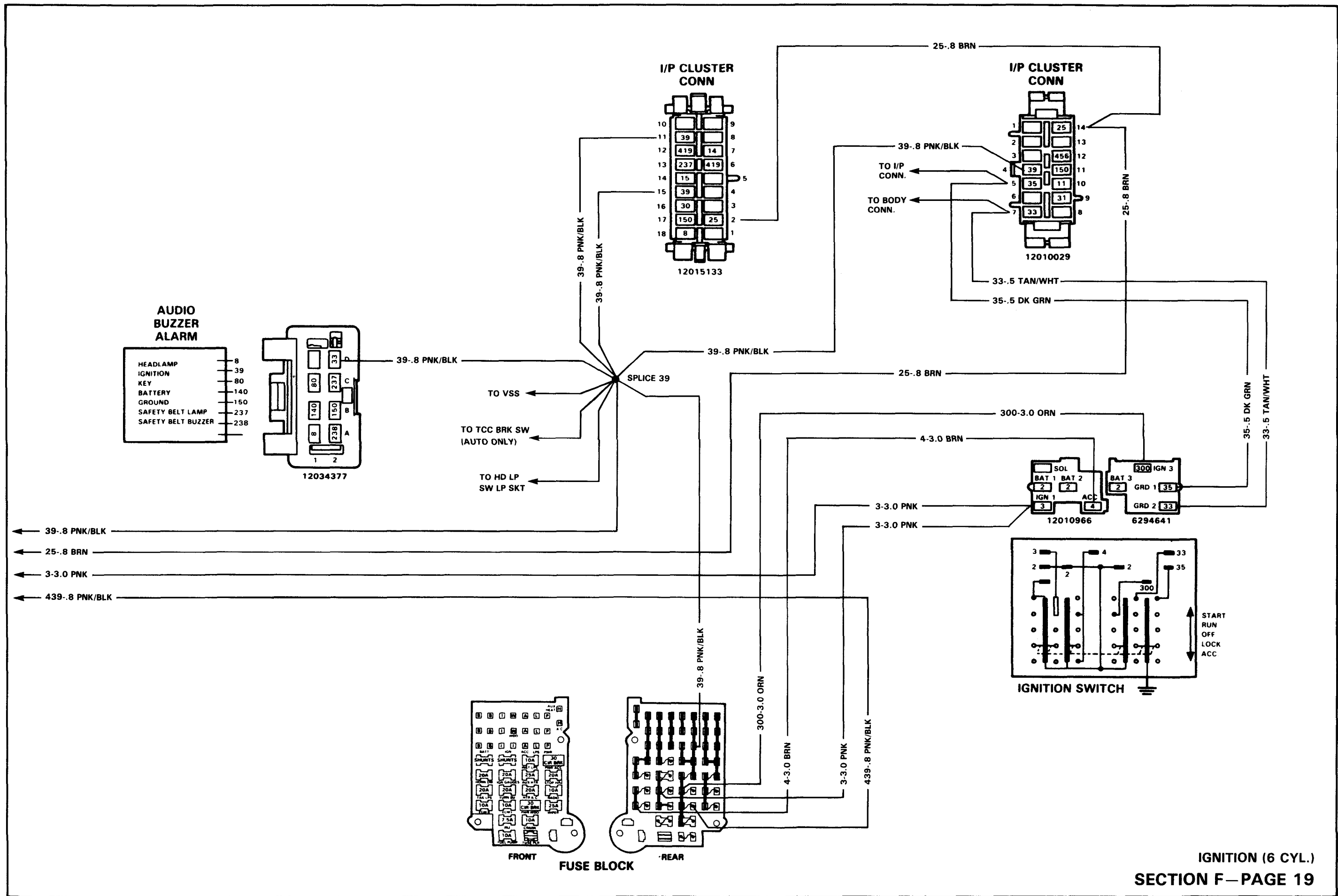

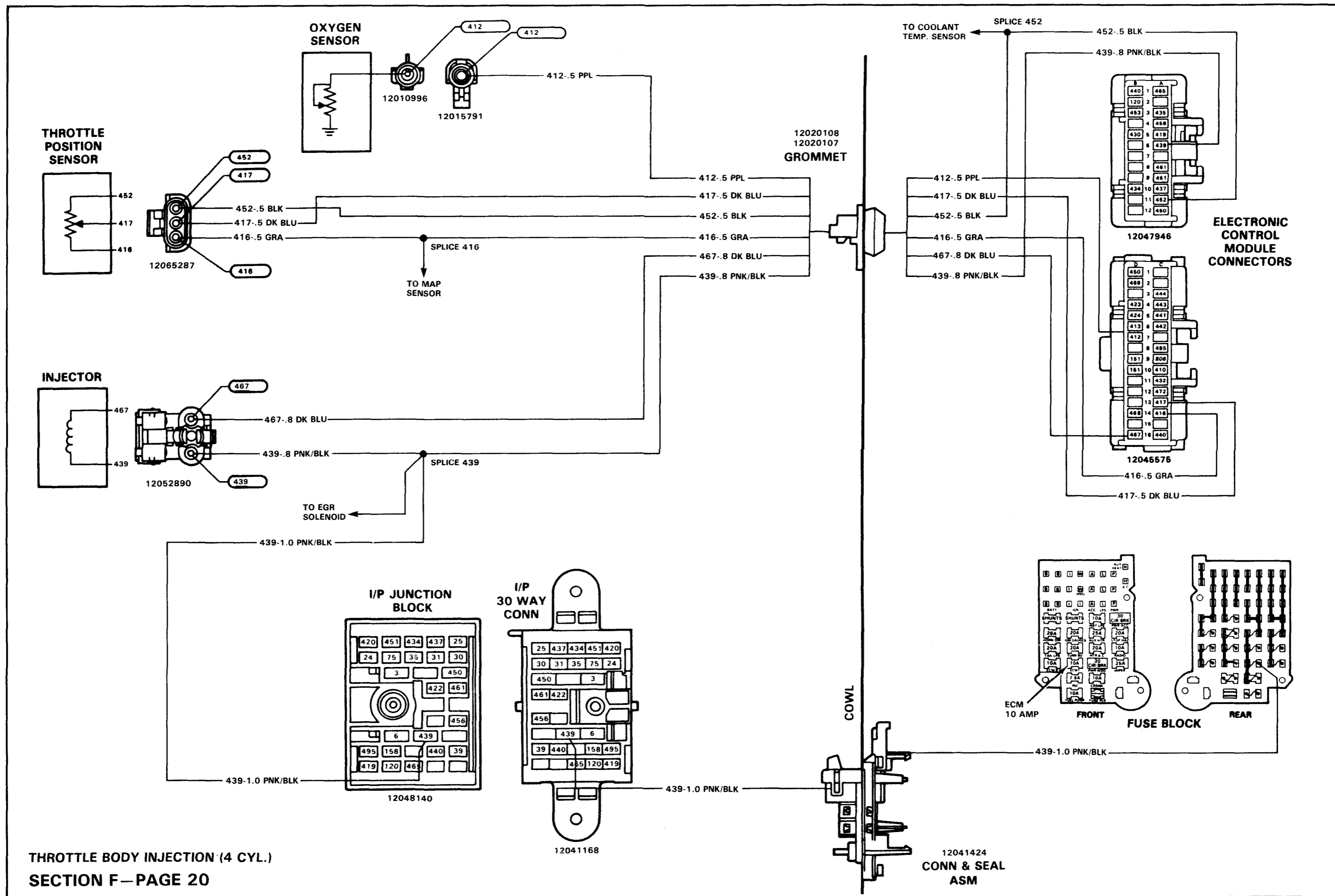

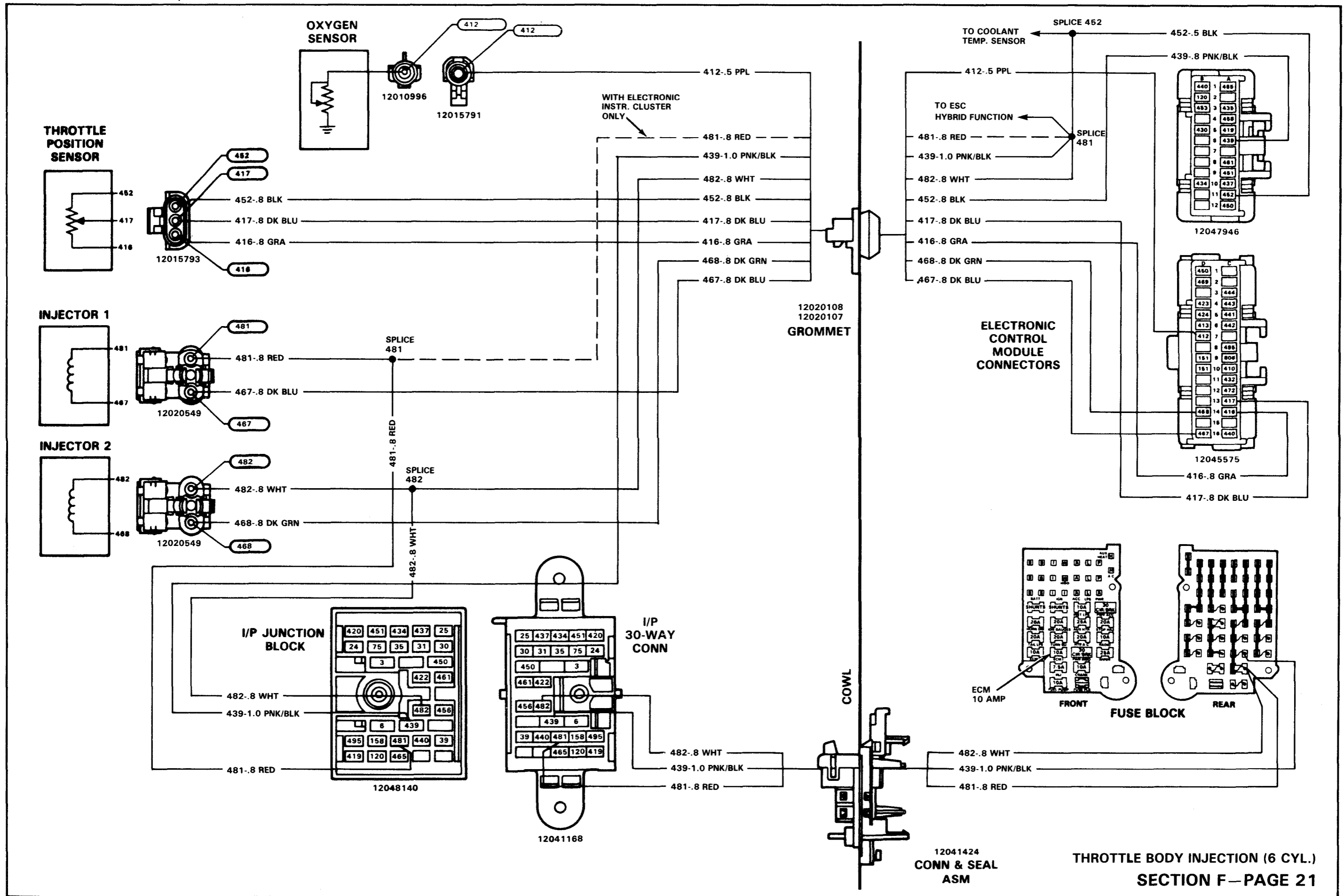

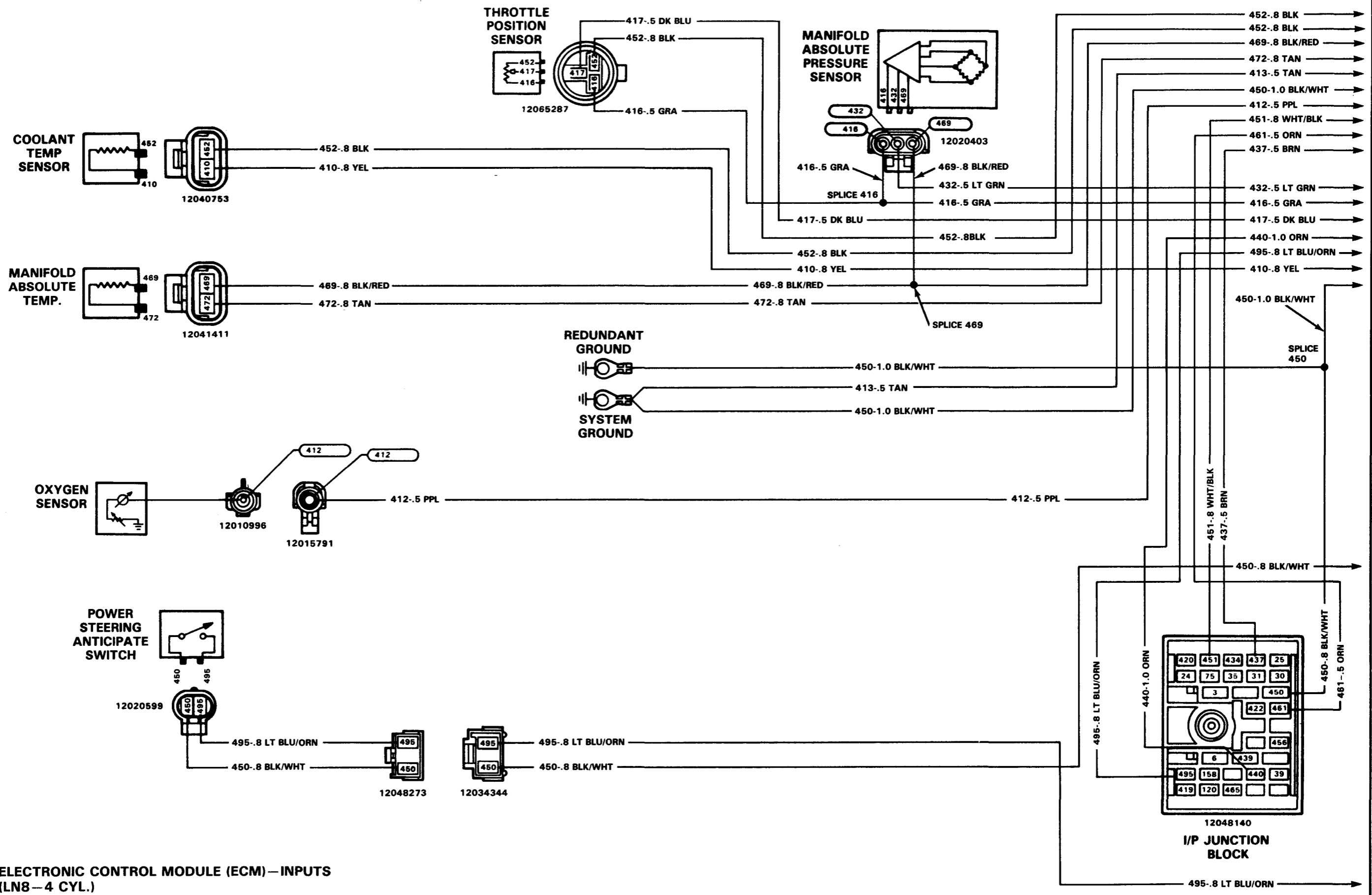

ELECTRONIC CONTROL MODULE (ECM)—INPUTS
(LN8—4 CYL.)

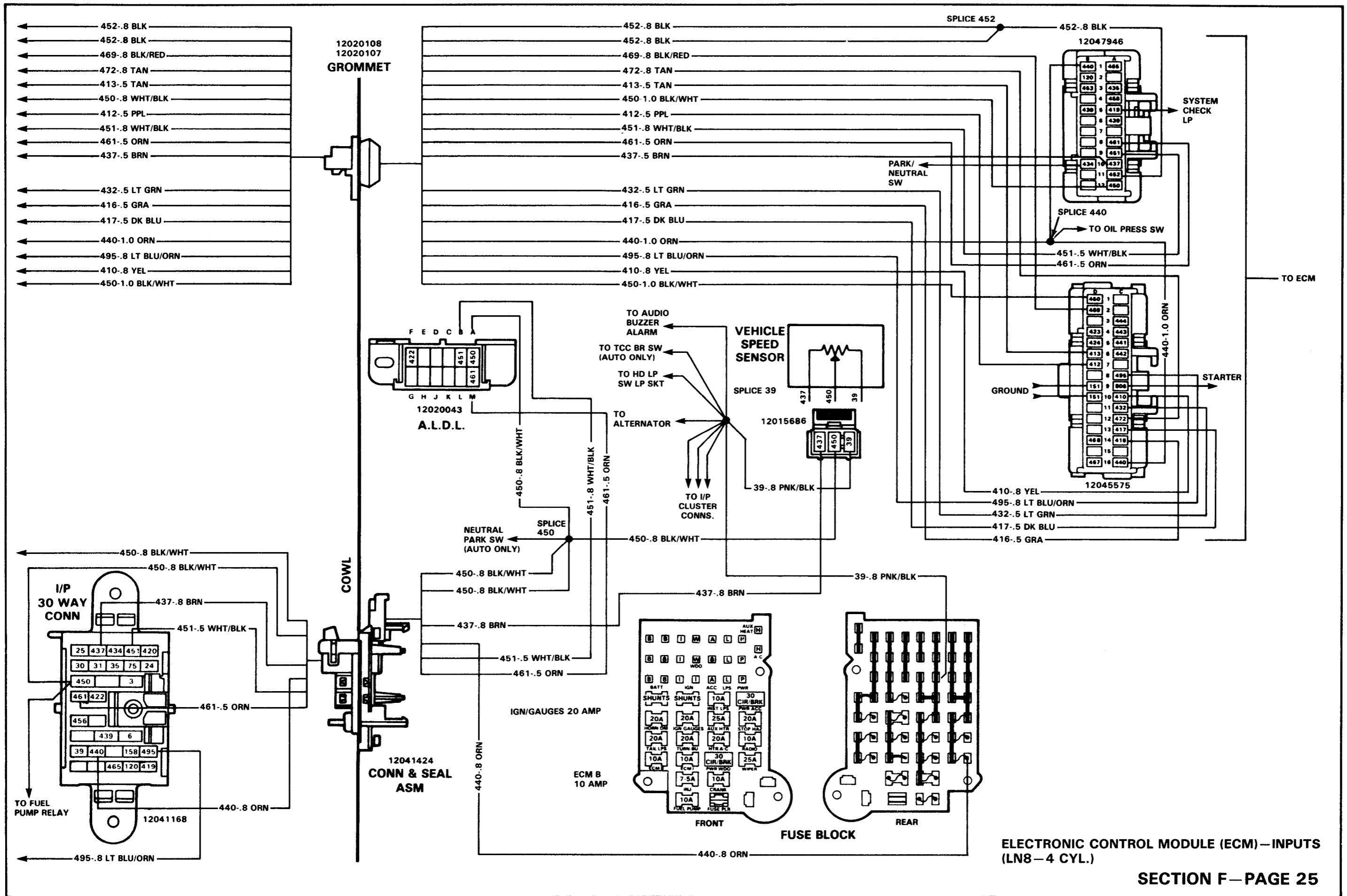

ELECTRONIC CONTROL MODULE (ECM) - INPUTS (LN8 - 4 Cyl.)

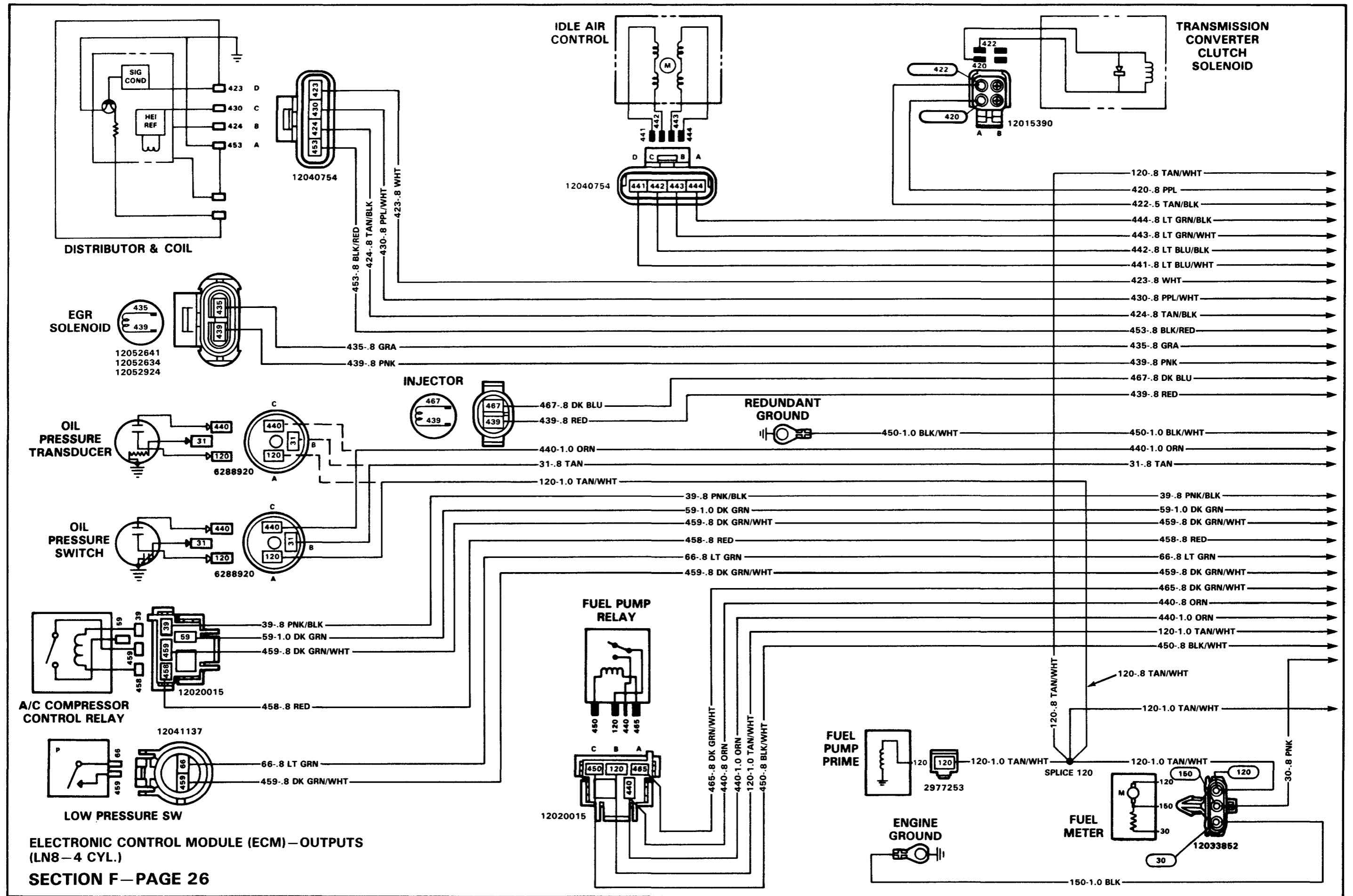

CIRCUIT NO.	WIRE SIZE	COLOR	CAVITY	DESCRIPTION
465	.8	DK GRN/WHT	A1	FUEL PUMP RELAY DRIVE
* 422	.5	TAN/BLK	A2	TORQUE CONVERTER CLUTCH
* 456	.5	TAN/BLK	A2	UPSHIFT MAN— ONLY
435	.8	GRA	A3	EGR SOLENOID
			A4	NOT USED
419	.5	BRN/WHT	A5	SYSTEM CHECK LAMP
439	.8	PNK/BLK	A6	12V IGNITION FUSED
			A7	NOT USED
461	.5	ORN	A8	SERIAL DATA
451	.8	WHT/BLK	A9	ASS'Y LINE LINK/DIAG.
437	.5	BRN	A10	SPEED SENSOR
452	.8	BLK	A11	5V RETURN B
450	1.0	BLK/WHT	A12	SYSTEM RETURN
440	1.0	ORN	B1	12V BATTERY FUSED
120	.8	TAN/WHT	B2	ELEC FUEL PUMP FUSED FEED
453	.8	BLK/RED	B3	DISTRIBUTOR REF LOW
			B4	NOT USED
430	.8	PPL/WHT	B5	DISTRIBUTOR REF HIGH
			B6	NOT USED
			B7	NOT USED
			B8	NOT USED
			B9	NOT USED
△ 434	.5	ORN/BLK	B10	PARK/NEUTRAL SWITCH
			B11	NOT USED
			B12	NOT USED

△ 422—AUTO TRANS ONLY
 * 456—MAN. TRANS ONLY } CAVITY A2

CIRCUIT NO.	WIRE SIZE	COLOR	CAVITY	DESCRIPTION
			C1	NOT USED
			C2	NOT USED
444	.8	LT GRN/BLK	C3	STEPPER COIL B LOW
443	.8	LT GRN/WHT	C4	STEPPER COIL B HIGH
441	.8	LT BLU/WHT	C5	STEPPER COIL A HIGH
442	.8	LT BLU/BLK	C6	STEPPER COIL A LOW
			C7	NOT USED
495	.8	LT BLU/ORN	C8	PWR STRG CUTOUT SW
806	1.0	PPI	C9	CRANK DISCRETE FUSED
410	.8	YEL	C10	COOLANT TEMPERATURE
432	.5	LT GRN	C11	MANIFOLD ABSOLUTE PRESS
472	.8	TAN	C12	MANIFOLD AIR TEMP SIGNAL
417	.5	DK BLU	C13	THROTTLE POSITION SENSOR
416	.5	GRA	C14	5V SENSOR REFERENCE
			C15	NOT USED
440	1.0	ORN	C16	12V BATTERY FUSED
450	1.0	BLK/WHT	D1	SYSTEM RETURN
469	.8	BLK/RED	D2	5V SYSTEM RETURN A
			D3	NOT USED
423	.8	WHT	D4	HEI SPARK TIMING
424	.8	TAN/BLK	D5	HEI BYPASS
413	.5	TAN	D6	OXYGEN SENSOR LOW
412	.5	PPL	D7	OXYGEN SENSOR HIGH
			D8	NOT USED
151	.8	BLK	D9	GROUND
151	.8	BLK	D10	GROUND
			D11	NOT USED
			D12	NOT USED
			D13	NOT USED
			D14	NOT USED
			D15	NOT USED
467	.8	DK BLU	D16	INJECTOR A DRIVE

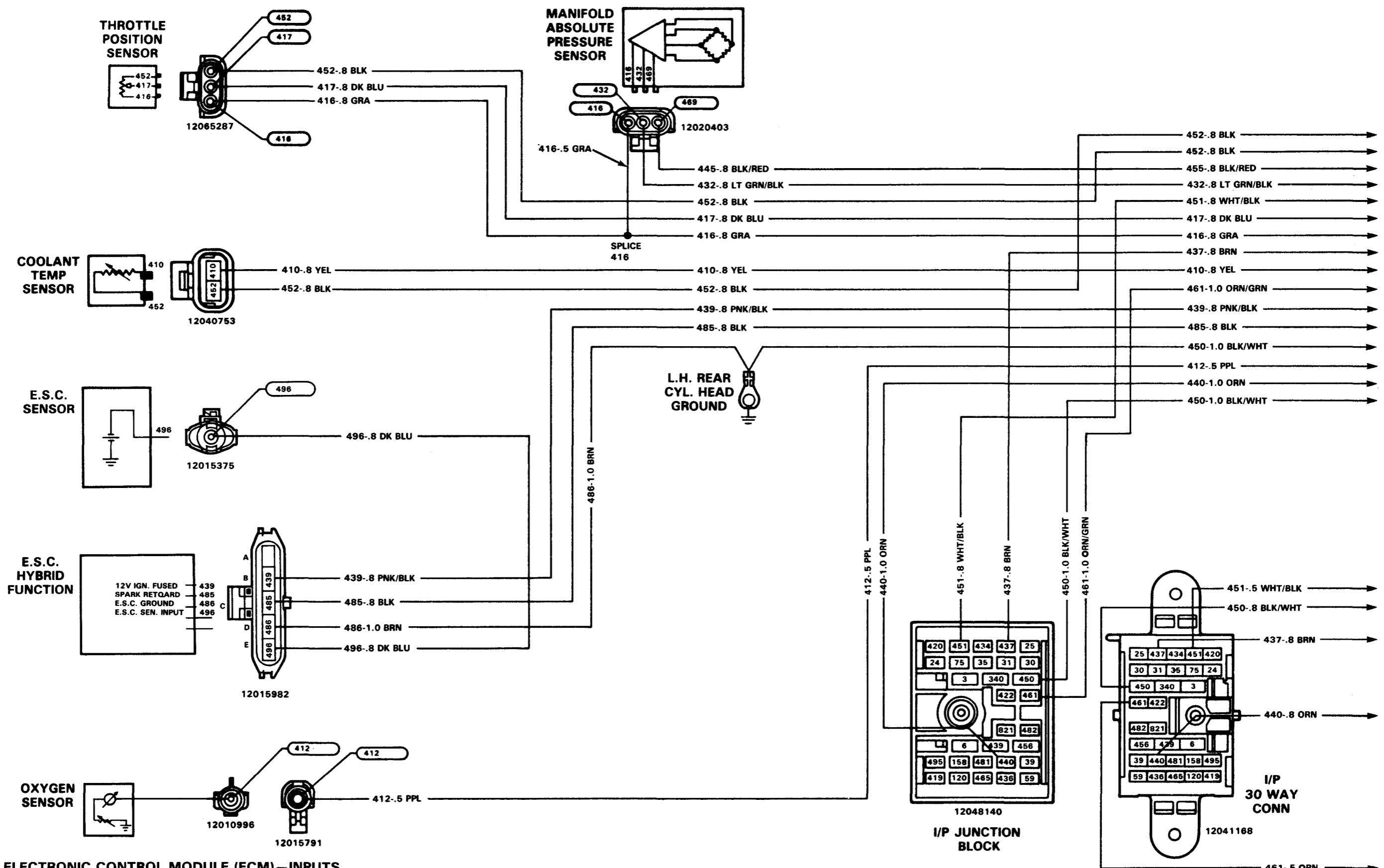

ELECTRONIC CONTROL MODULE (ECM)—INPUTS (LB4—V6)
SECTION F—PAGE 30

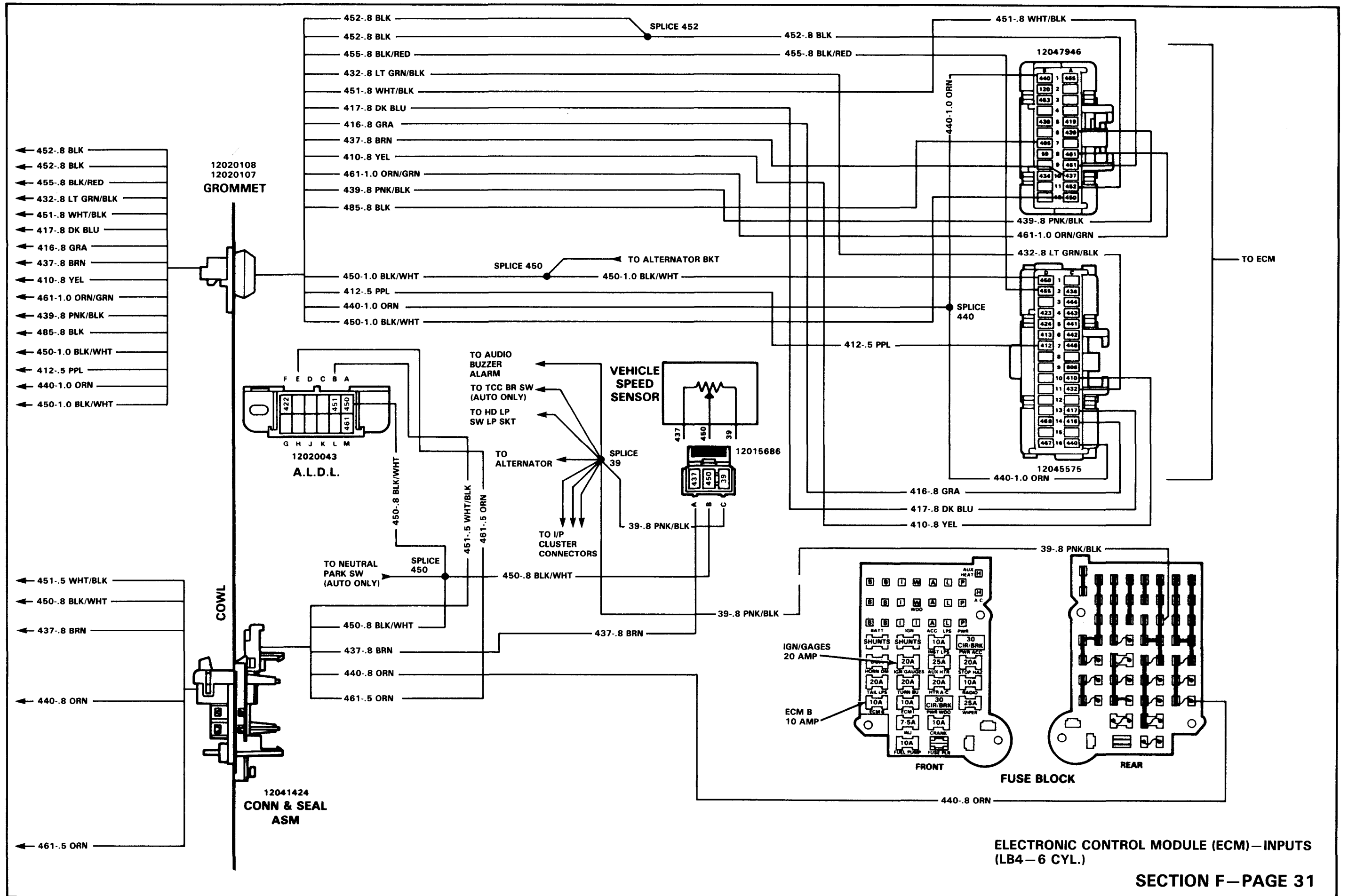

ELECTRONIC CONTROL MODULE (ECM) – INPUTS
(LB4 – 6 CYL.)

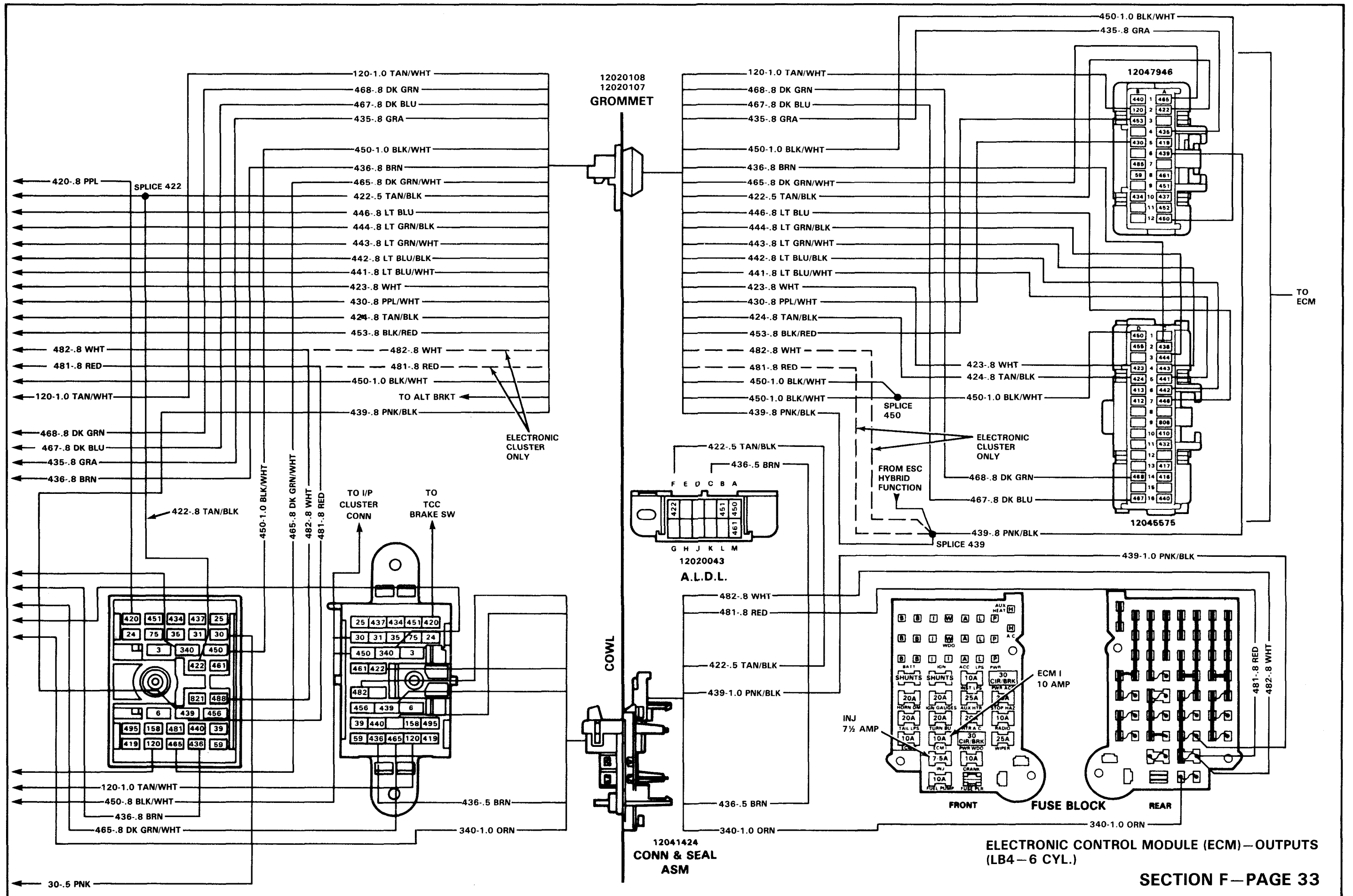

CIRCUIT NO.	WIRE SIZE	COLOR	CAVITY	DESCRIPTION
465	.8	DK GRN/WHT	A1	FUEL PUMP RELAY DRIVE
			A2	NOT USED
			A3	NOT USED
435	.8	GRA	A4	EGR/EFE
419	.8	BRN/WHT	A5	SYSTEM CHECK LAMP
439	1.0	PNK/BLK	A6	12V IGNITION FUSED
* 422	.8	TAN/BLK	A7	TORQUE CONVERTER CLUTCH
* 456	.8	TAN/BLK	A7	UPSHIFT MAN— ONLY
461	.8	ORN/BLK	A8	SERIAL DATA
451	.8	WHT/BLK	A9	ASS'Y LINE LINK/DIAG.
437	.8	BRN	A10	SPEED SENSOR
452	.8	BLK	A11	5V RETURN B
450	1.0	BLK/WHT	A12	SYSTEM RETURN
440	1.0	ORN	B1	12V BATTERY FUSED
120	1.0	TAN/WHT	B2	ELEC FUEL PUMP FUSED FEED
453	.8	BLK/RED	B3	DISTRIBUTOR REF LOW
			B4	NOT USED
430	.8	PPL/WHT	B5	DISTRIBUTOR REF HIGH
			B6	NOT USED
485	.8	BLK	B7	SPARK RETARD CONTROL
59	.8	DK GRN/WHT	B8	AIR CONDITION
			B9	NOT USED
△ 434	.5	ORN/BLK	B10	PARK/NEUTRAL SWITCH
			B11	NOT USED
			B12	NOT USED

* 422—AUTO TRANS ONLY } CAVITY A2
 * 456—MAN. TRANS ONLY }
 △ AUTO TRANS ONLY

CIRCUIT NO.	WIRE SIZE	COLOR	CAVITY	DESCRIPTION
			C1	NOT USED
436	.8	BRN	C2	AIR SW SOLENOID
444	.8	LT GRN/BLK	C3	STEPPER COIL B LOW
443	.8	LT GRN/WHT	C4	STEPPER COIL B HIGH
441	.8	LT BLU/WHT	C5	STEPPER COIL A HIGH
442	.8	LT BLU/BLK	C6	STEPPER COIL A LOW
446	.8	LT BLU	C7	HIGH GEAR
			C8	NOT USED
806	.8	PPL/WHT STR	C9	CRANK DISCRETE FUSED
410	.8	YEL	C10	COOLANT TEMPERATURE
432	.8	LT GRN/BLK STR	C11	MANIFOLD ABSOLUTE PRESS
			C12	NOT USED
417	.8	DK BLU	C13	THROTTLE POSITION SENSOR
416	.8	GRA	C14	5V SENSOR REFERENCE
			C15	NOT USED
440	1.0	ORN	C16	12V BATTERY FUSED
450	1.0	BLK/WHT	D1	SYSTEM RETURN
455	.8	BLK/RED	D2	5V SYSTEM RETURN A
			D3	NOT USED
423	.8	WHT	D4	HEI SPARK TIMING
424	.8	TAN/BLK	D5	HEI BYPASS
413	.8	TAN	D6	OXYGEN SENSOR LOW
412	.8	PPL	D7	OXYGEN SENSOR HIGH
			D8	NOT USED
			D9	NOT USED
			D10	NOT USED
			D11	NOT USED
			D12	NOT USED
			D13	NOT USED
468	.8	DK GRN	D14	INJECTOR B DRIVE
			D15	NOT USED
467	.8	DK BLU	D16	INJECTOR A DRIVE

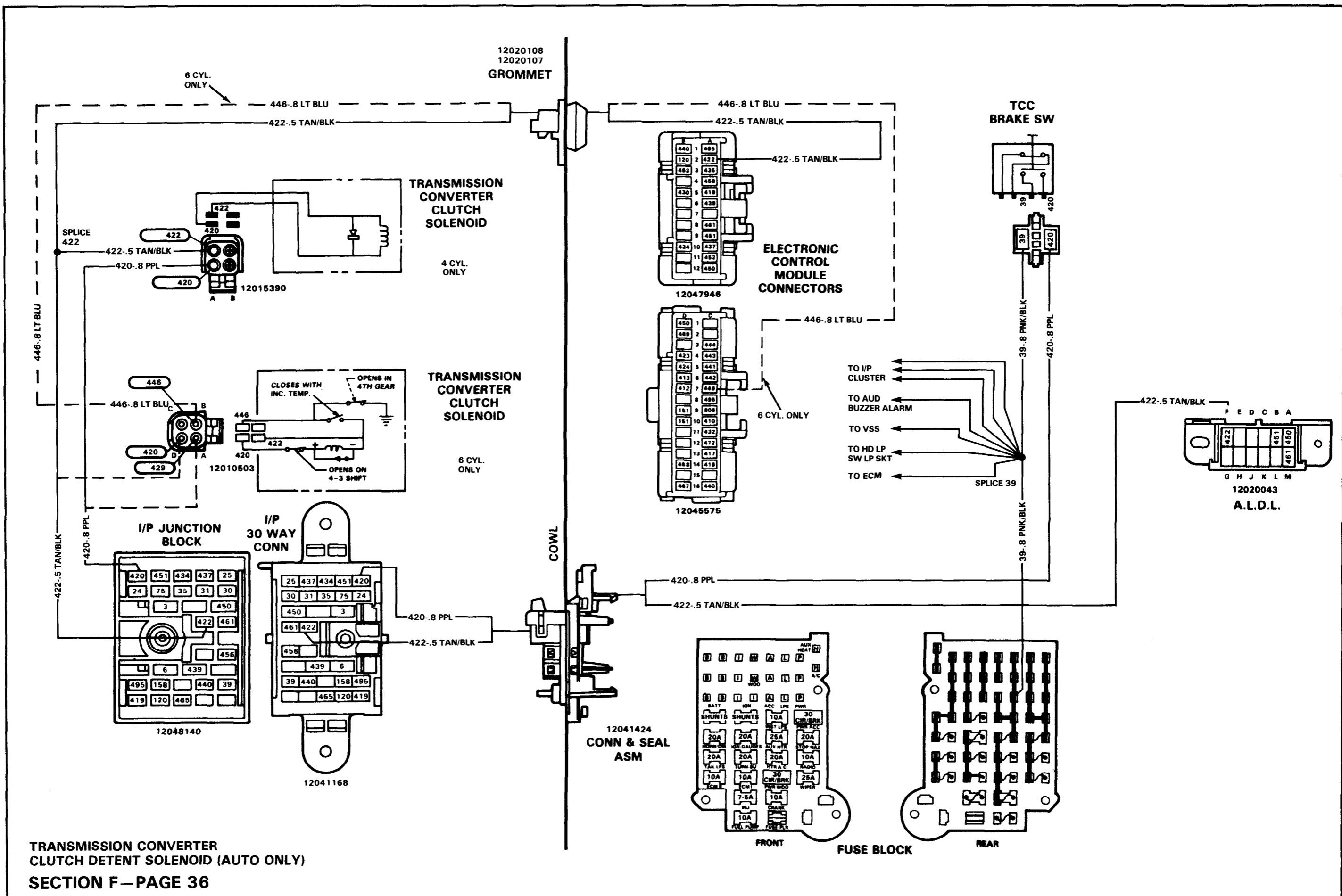

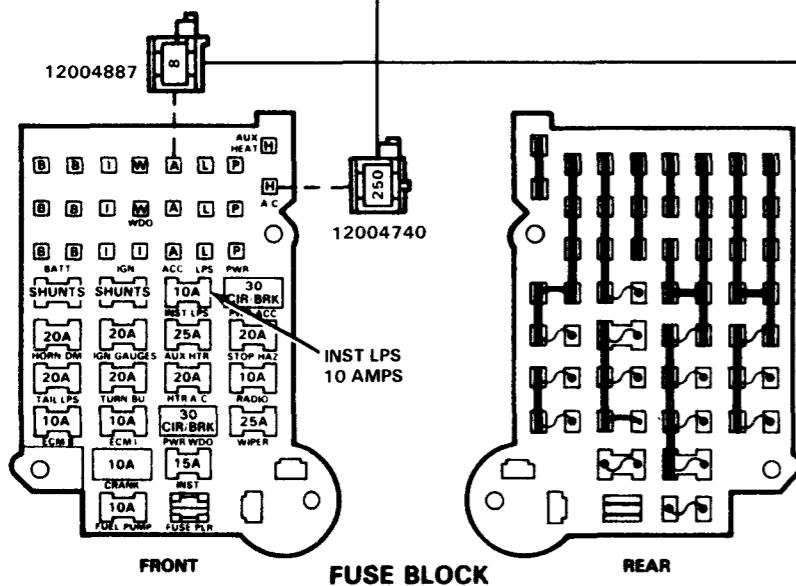
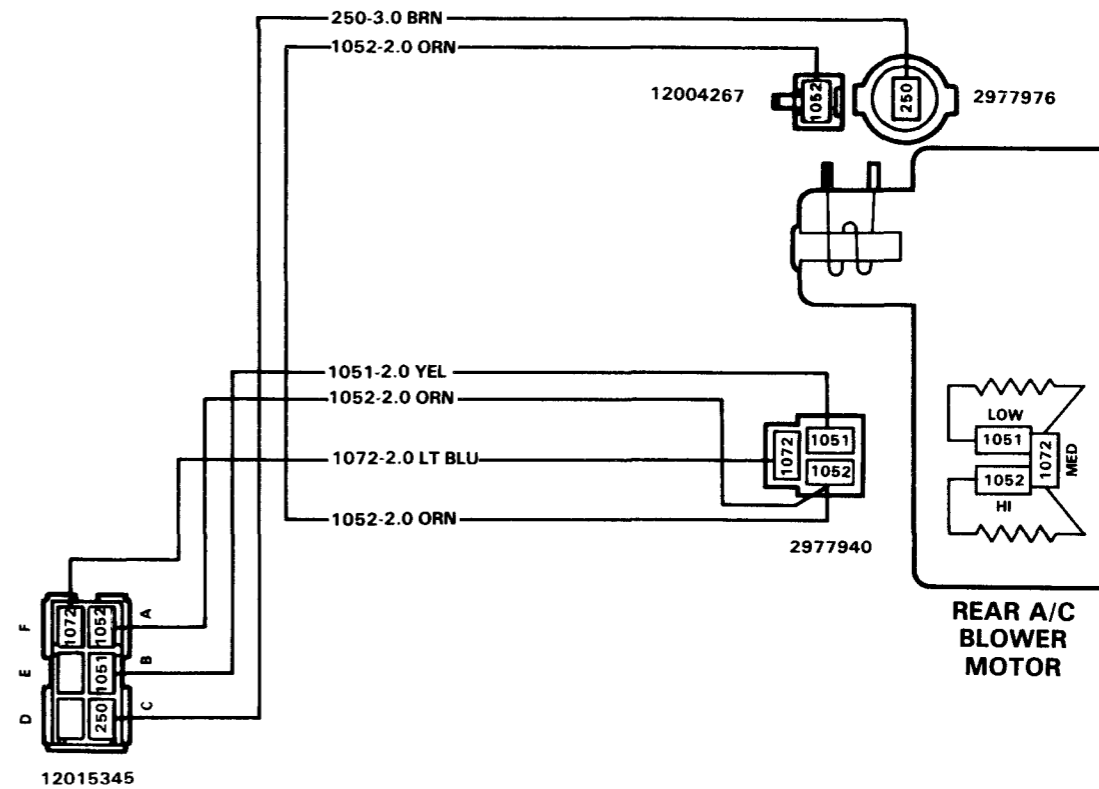
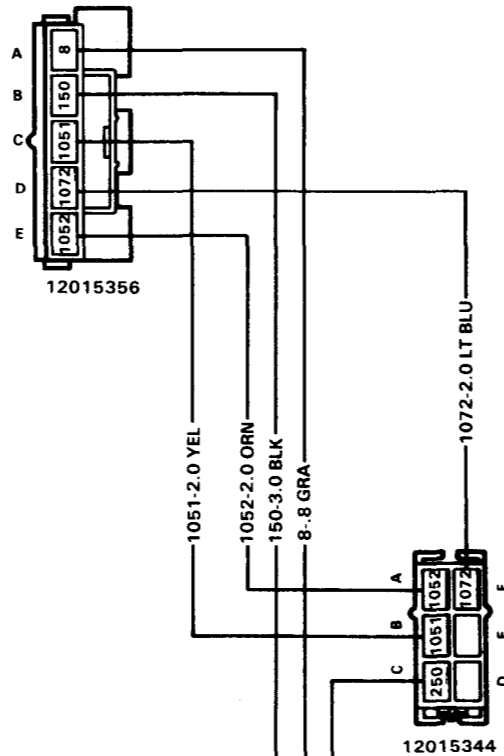
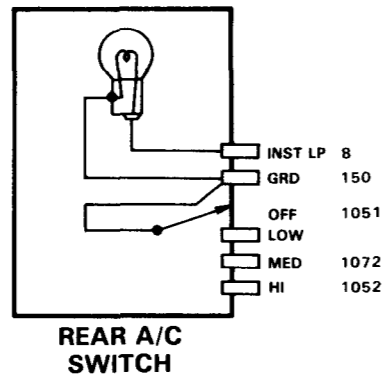

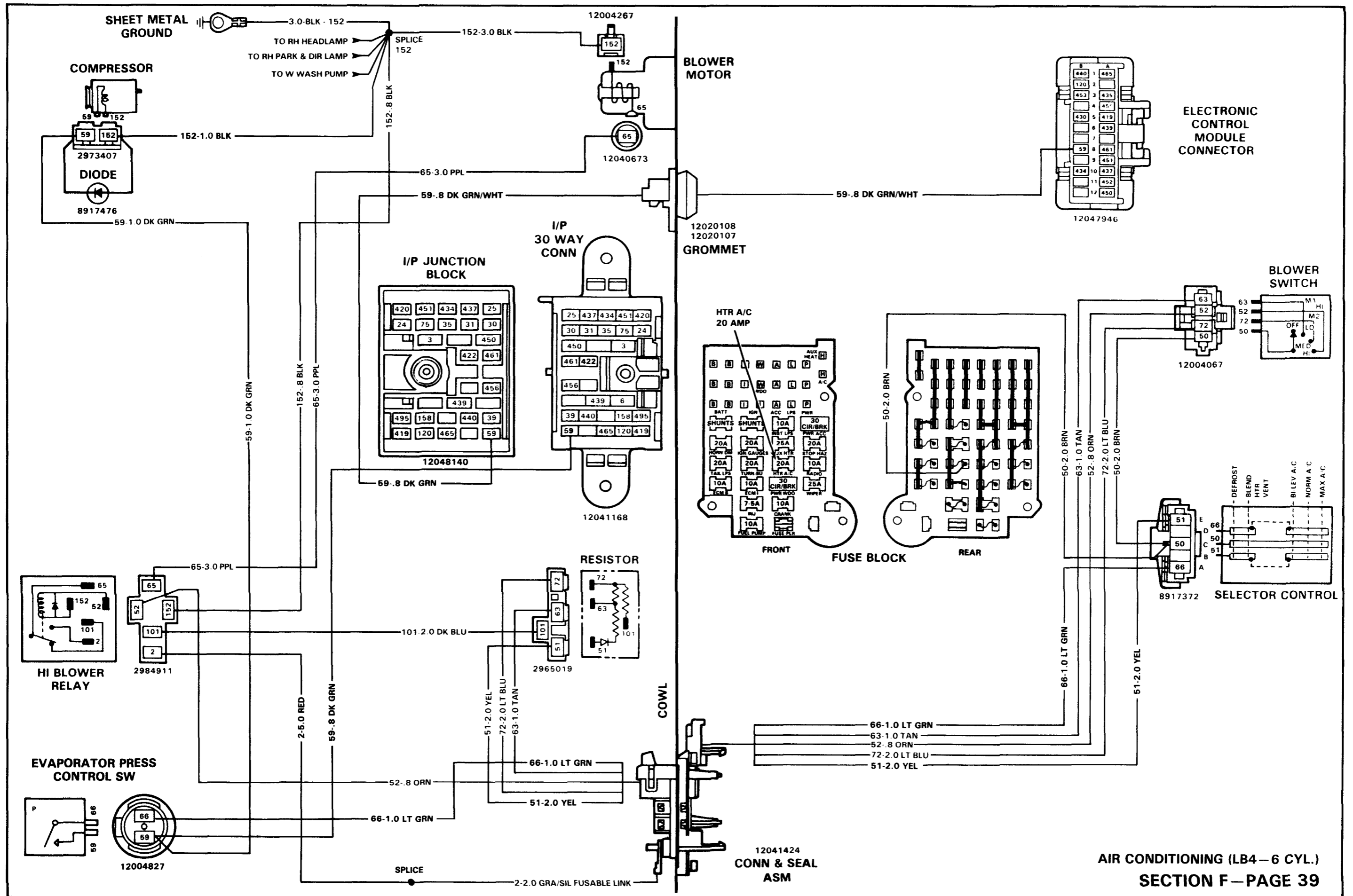

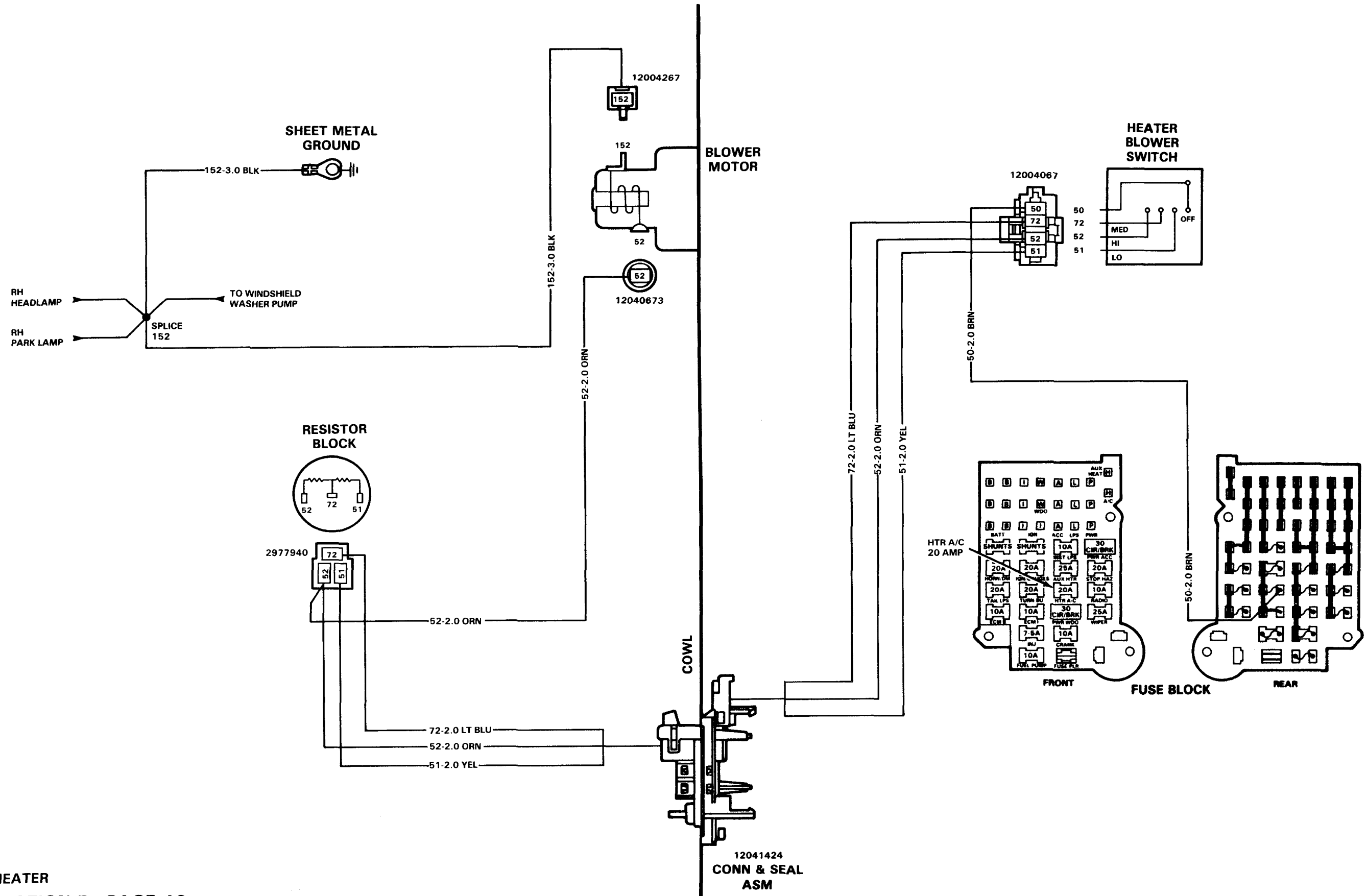

AUXILIARY HEATER CONTROL SWITCH

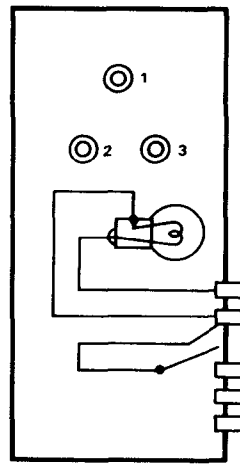

- 1 VACUUM SOURCE
- 2 LO. MED & HI PORT
- 3 HI PORT

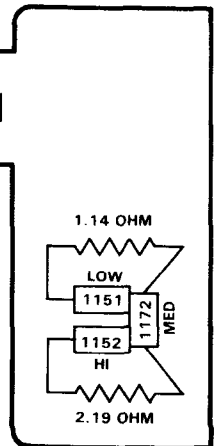
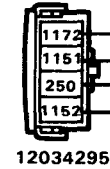
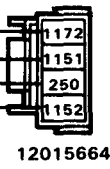
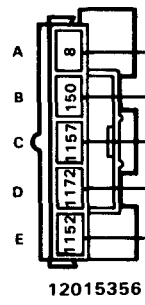

REAR AUXILIARY HEATER BLOWER MOTOR

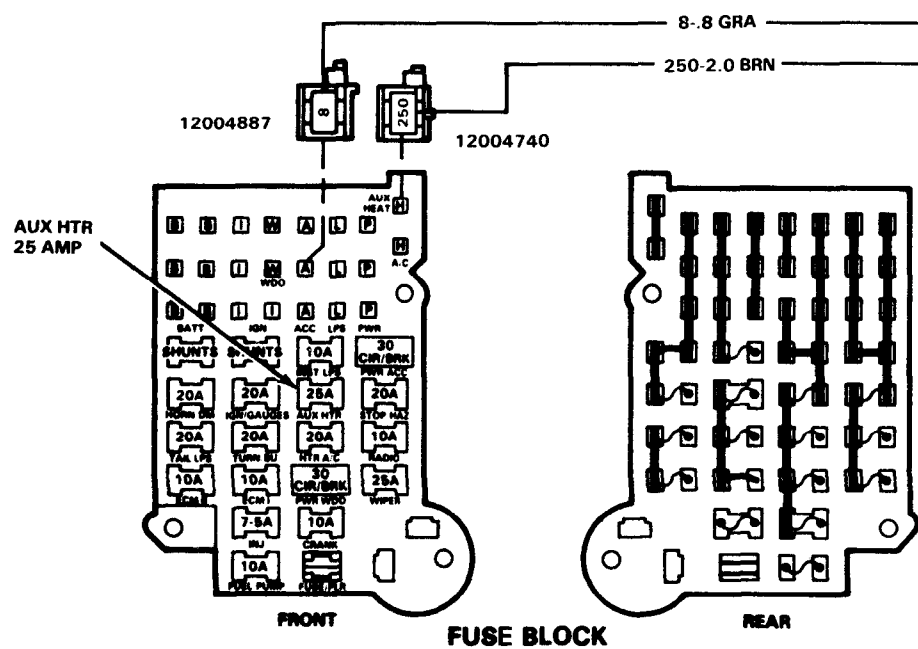

FUSE BLOCK

- 250-3.0 BRN
- 1152-3.0 WHT
- 1172-2.0 LT BLU
- 1151-2.0 YEL
- 8-8 GRA
- 250-2.0 BRN

- 250-3.0 BRN
- 1152-3.0 WHT



- 8-8 GRA
- 250-2.0 BRN
- 8-8 GRA
- 250-3.0 BRN

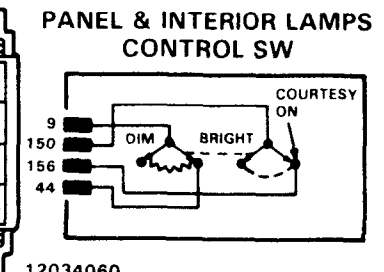
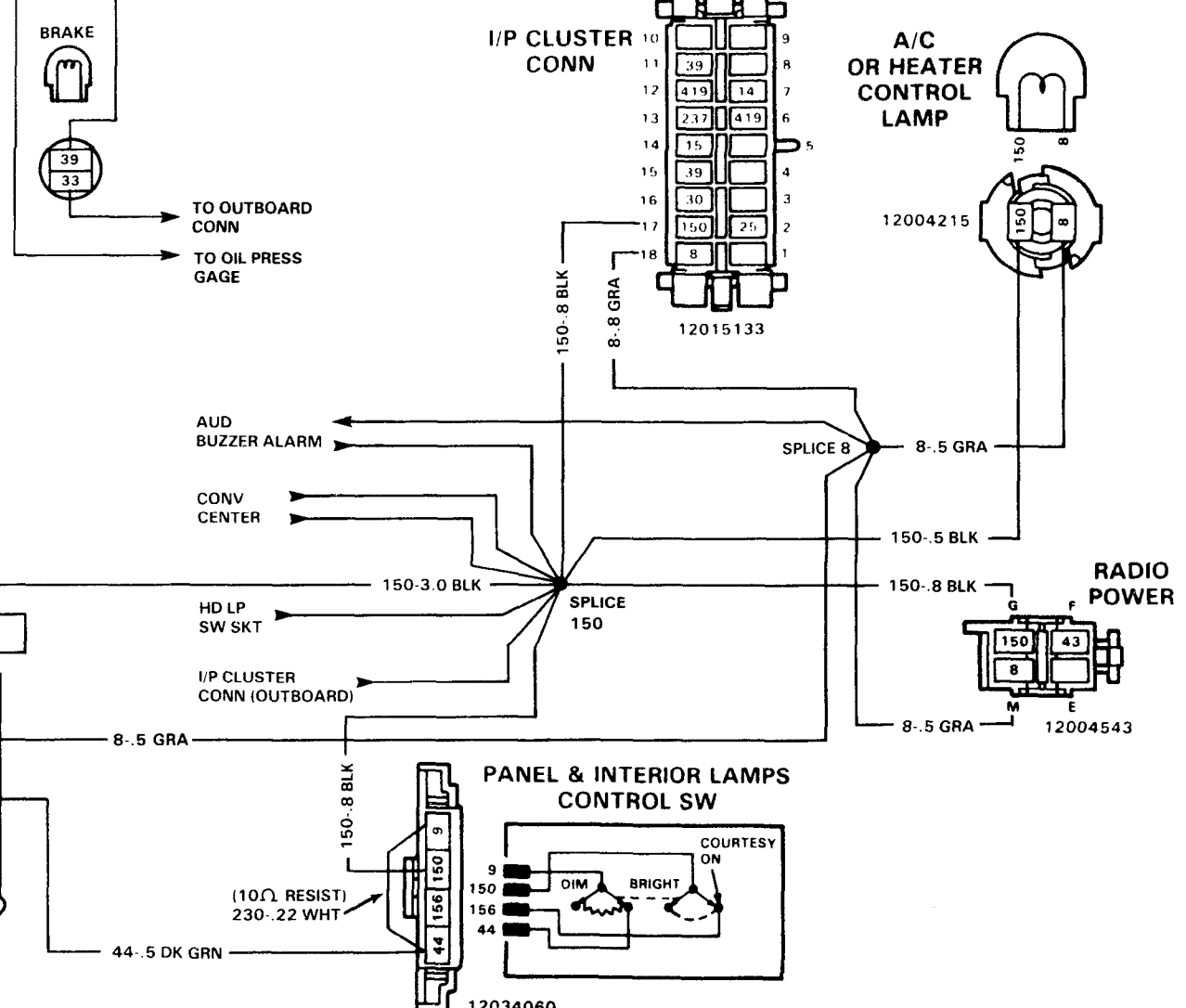
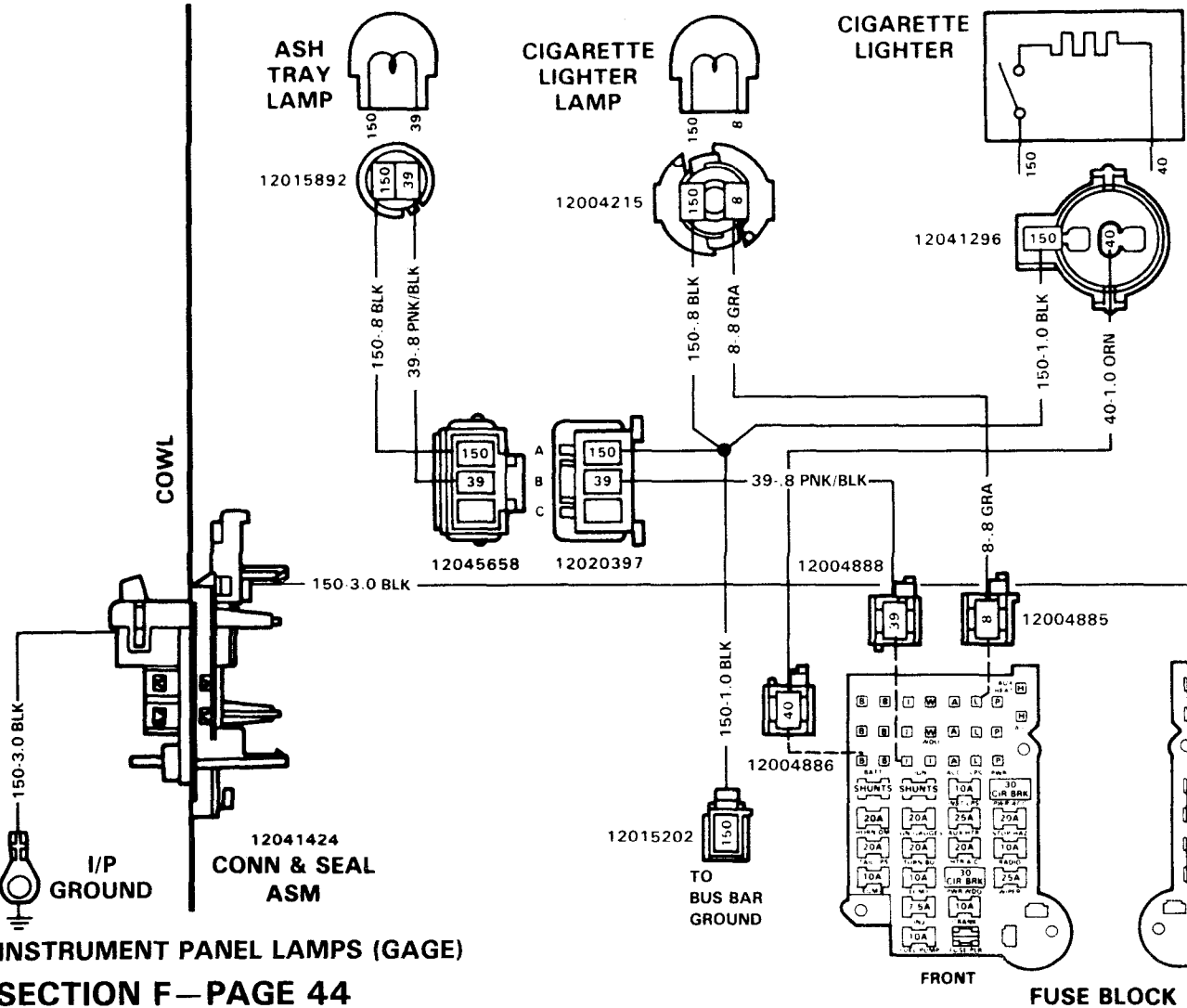
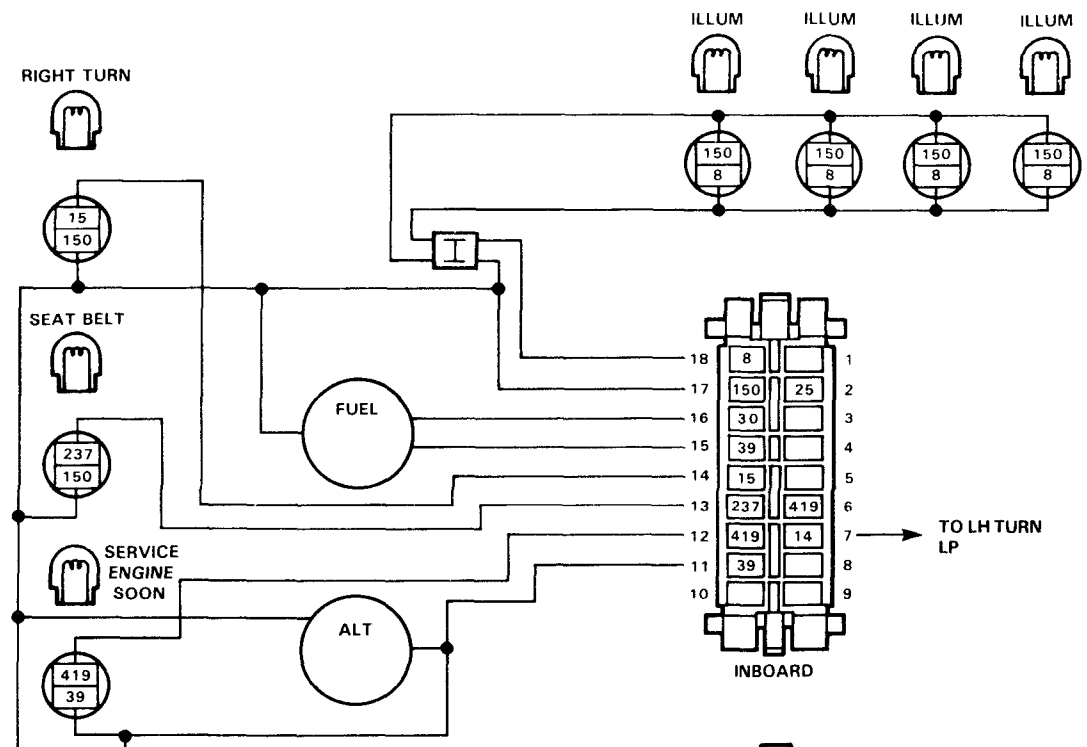
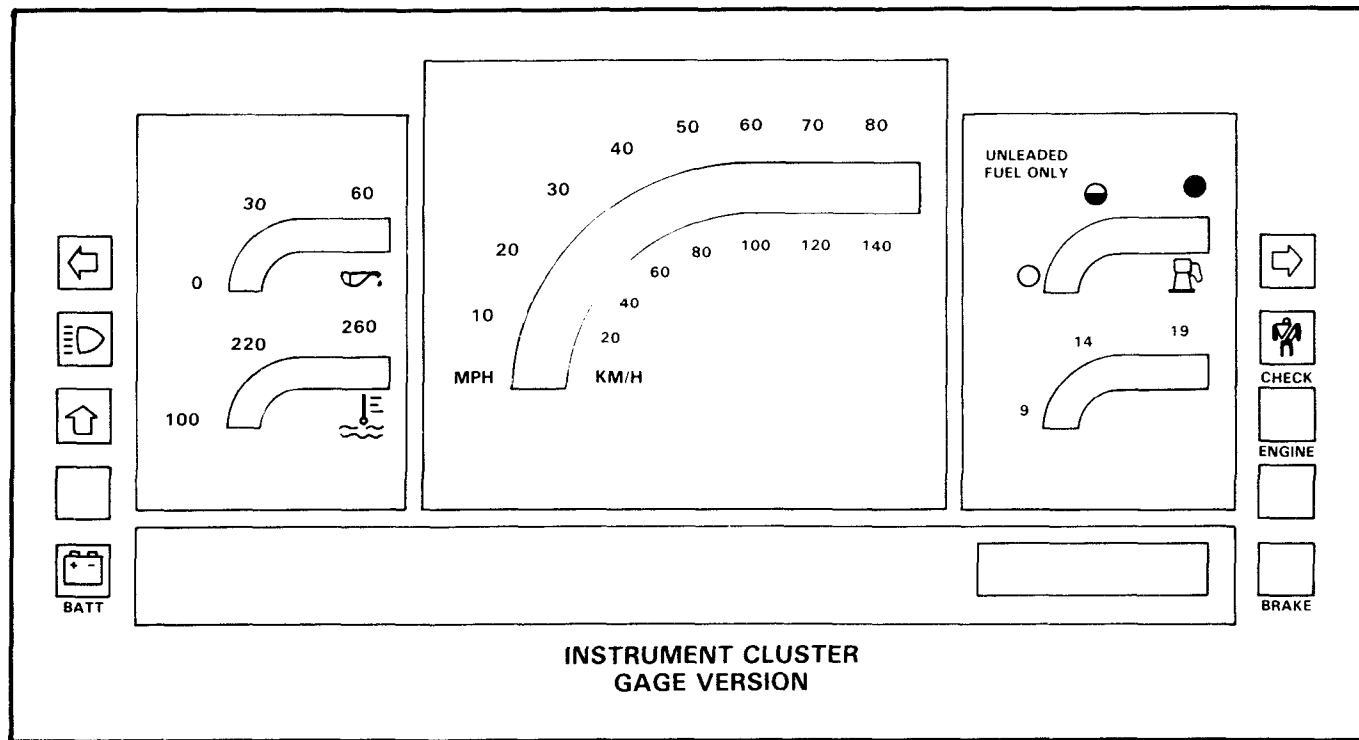

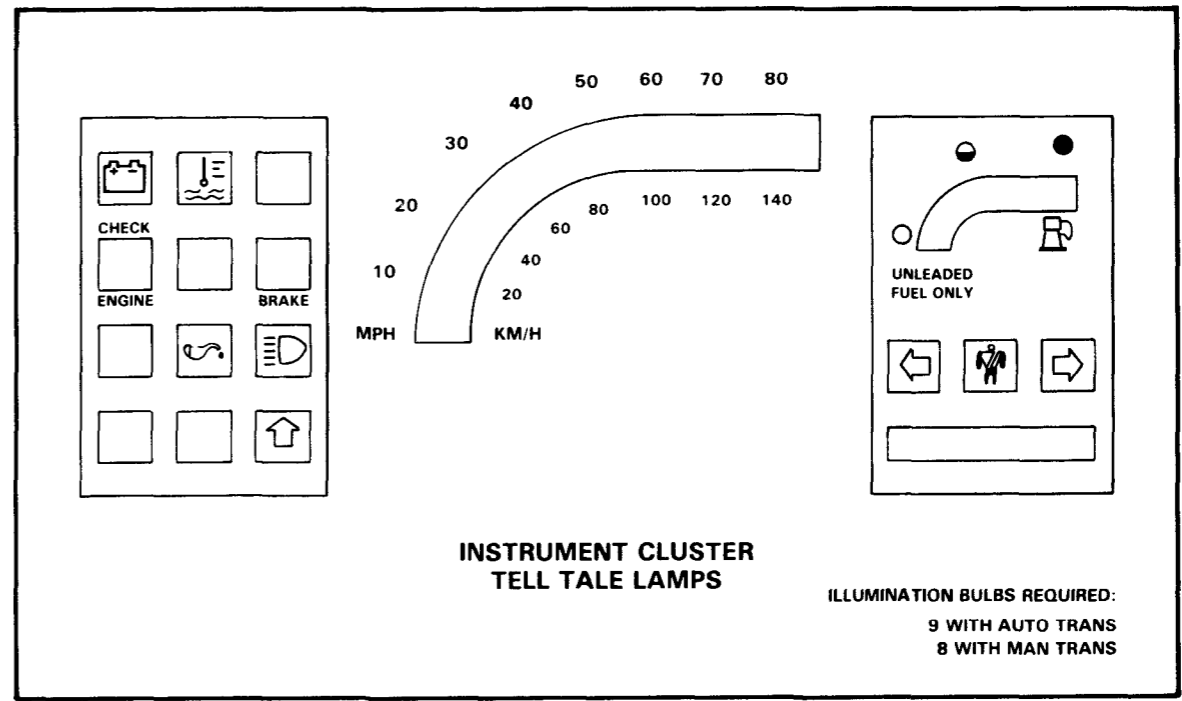
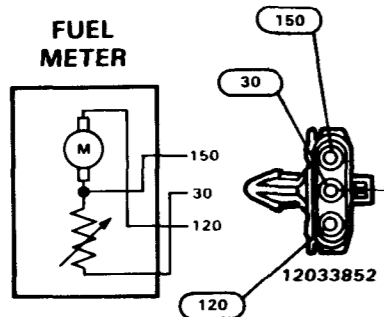

30-.5 PNK

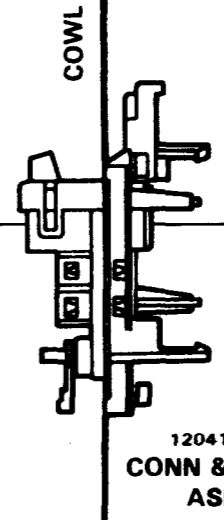
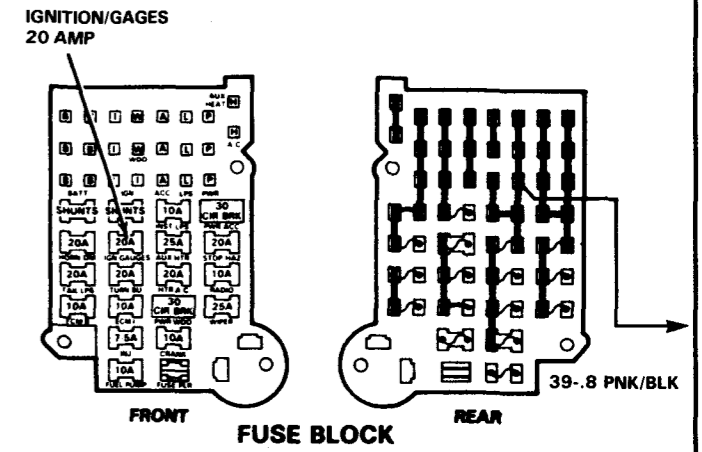
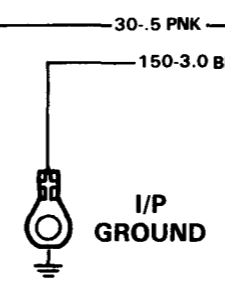
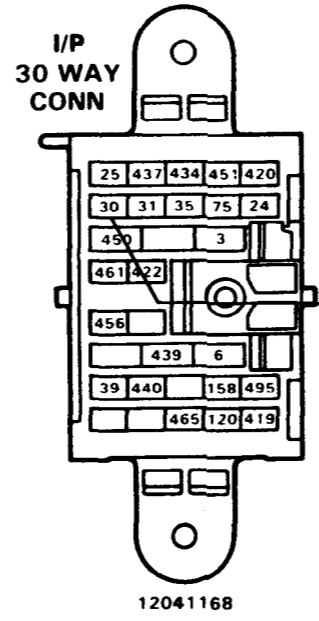
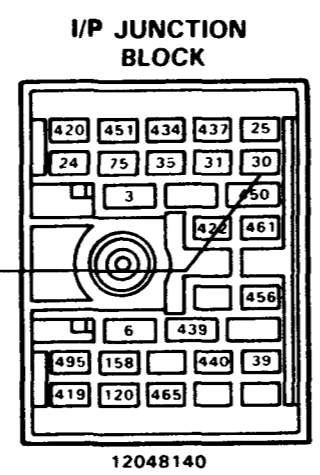

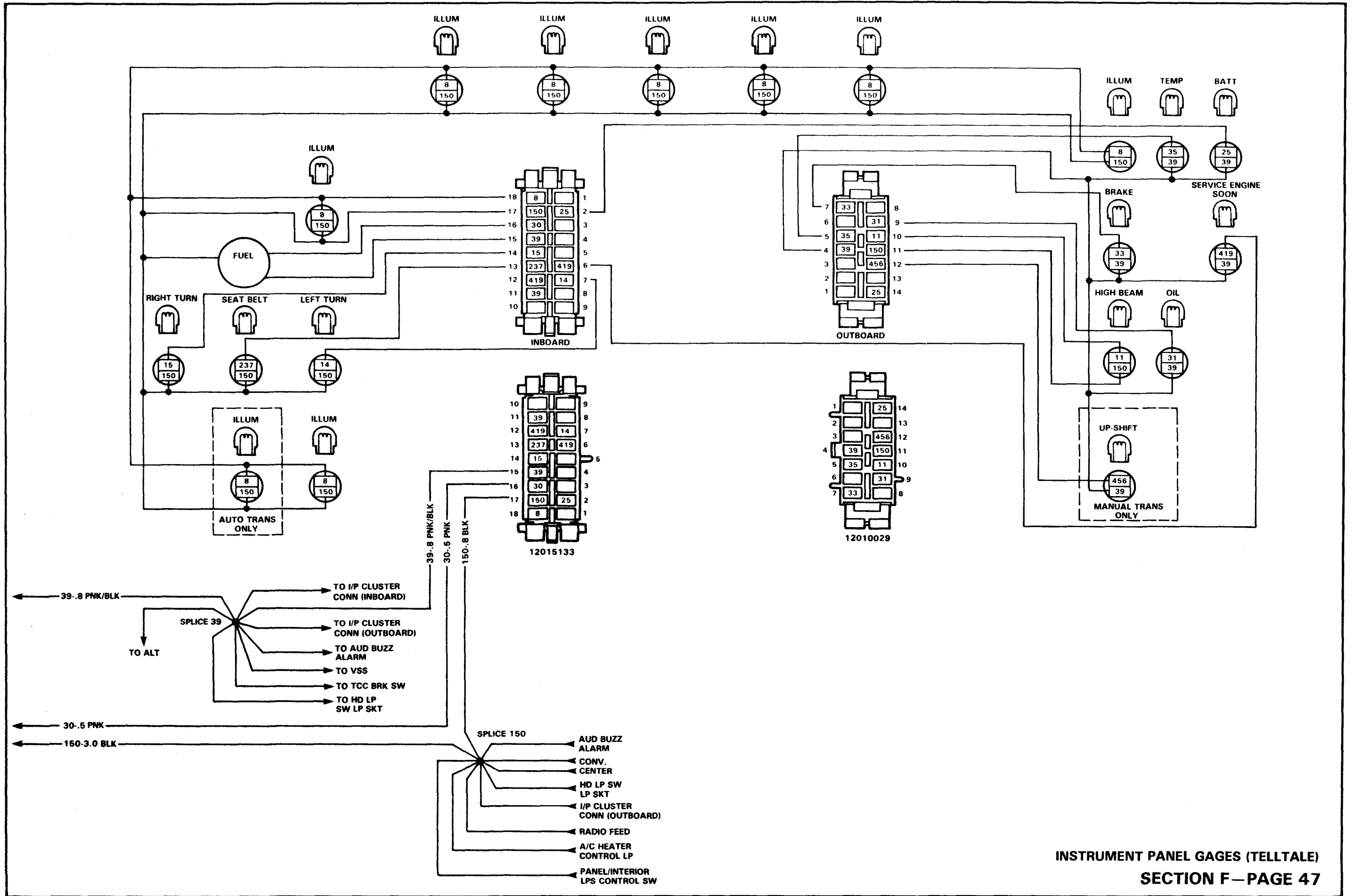

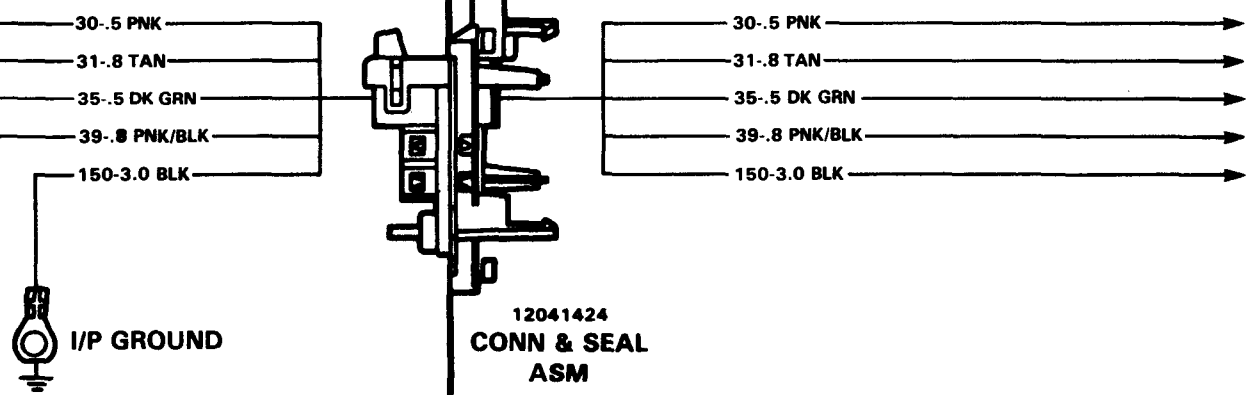
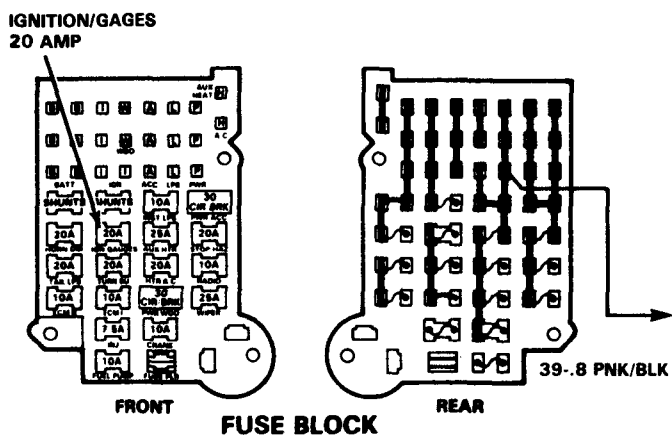
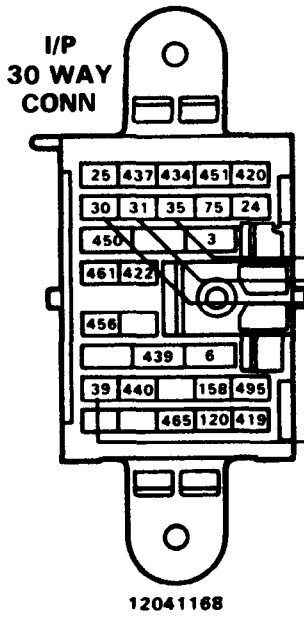
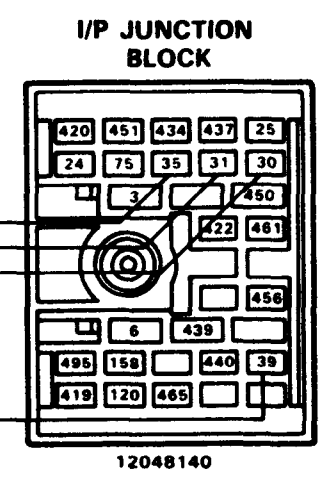
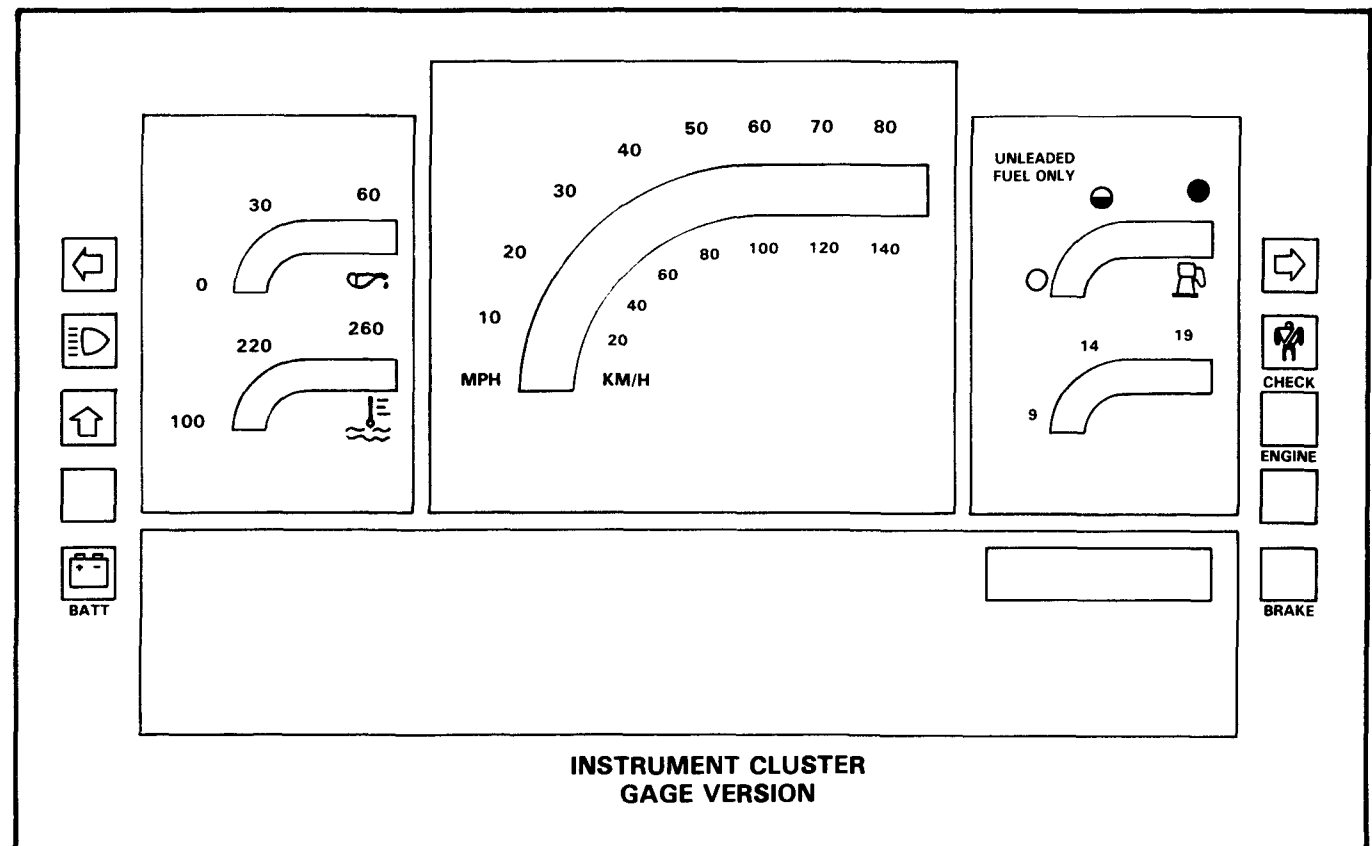
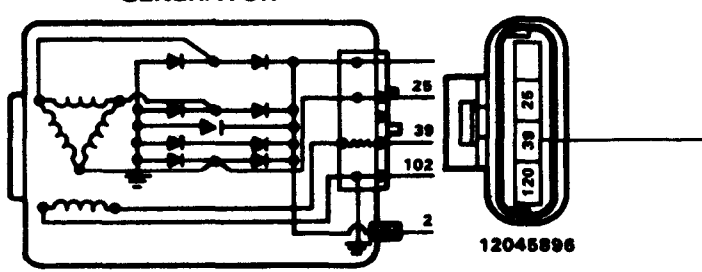
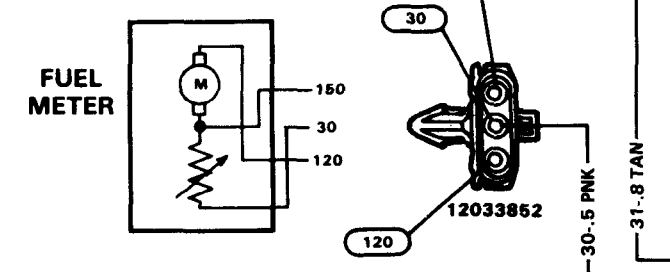
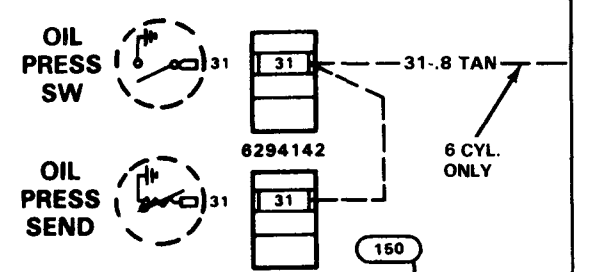
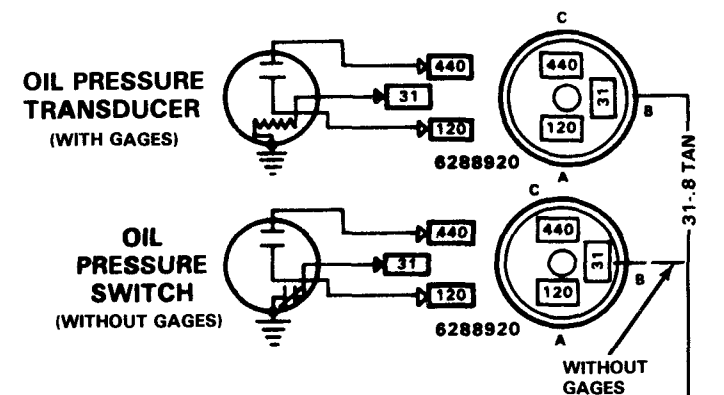
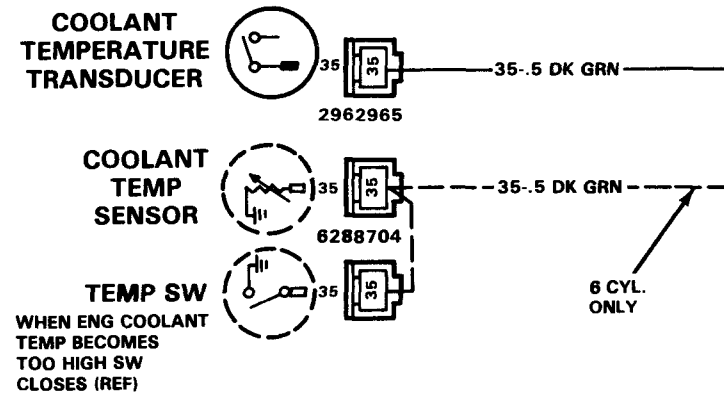

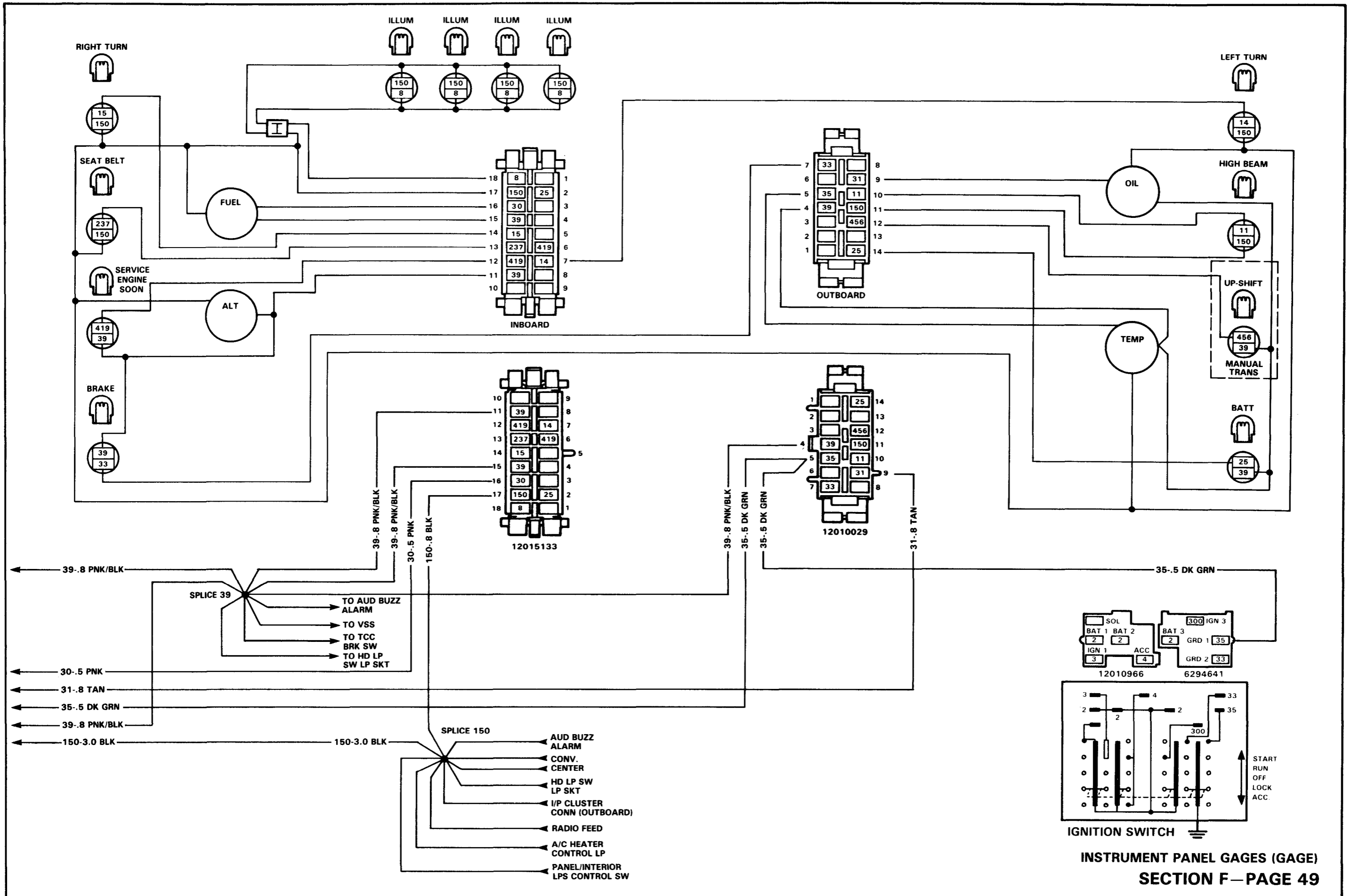

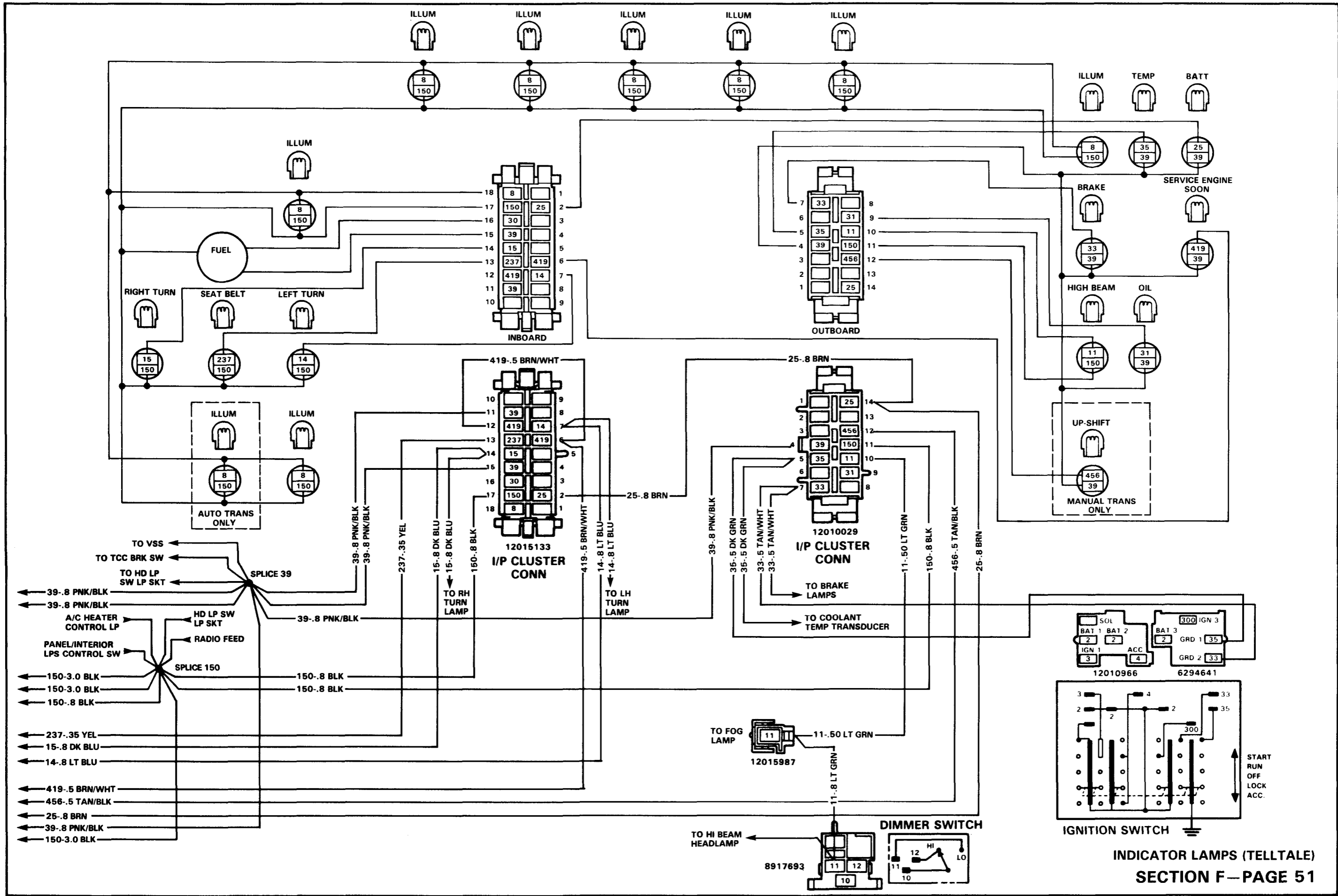

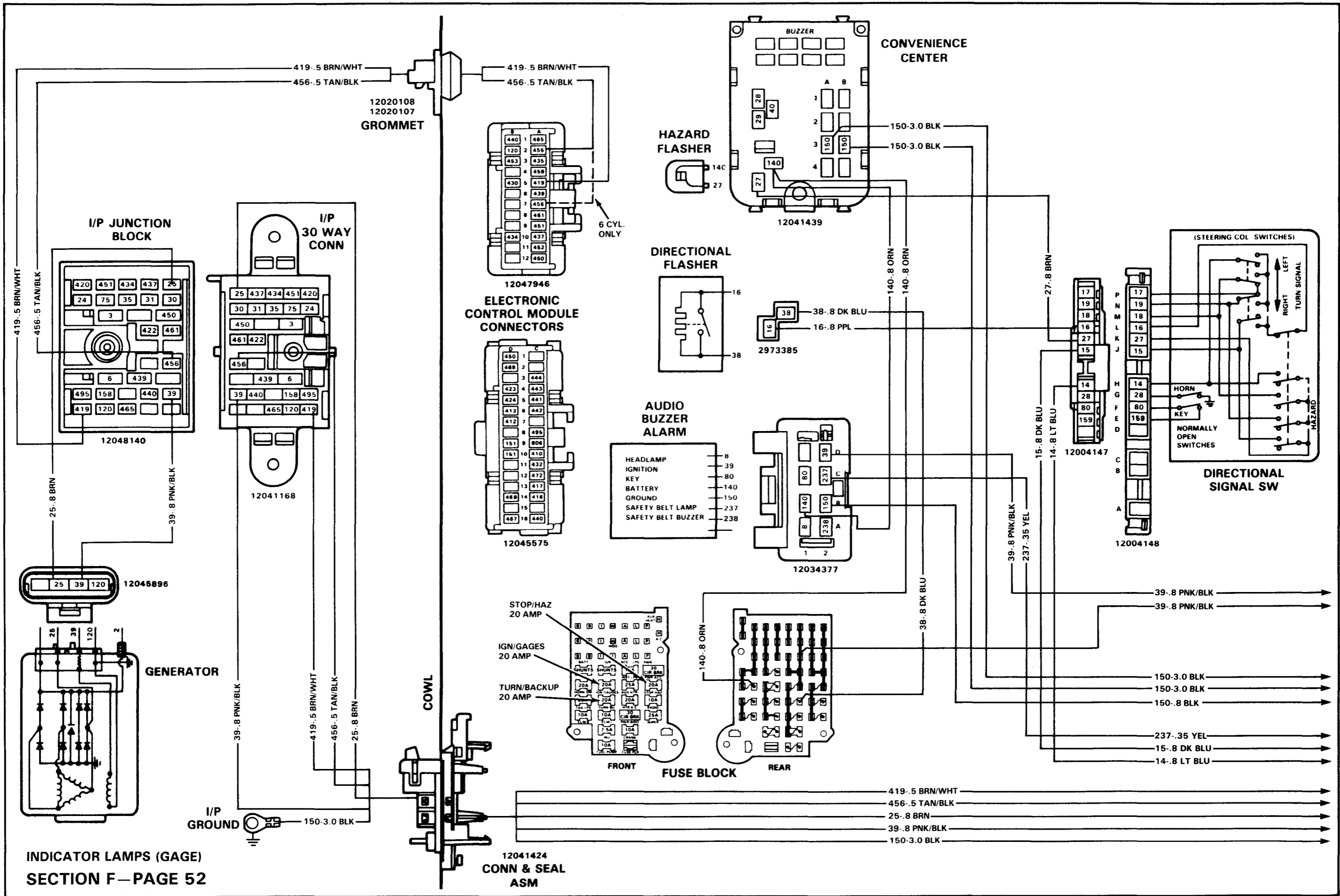

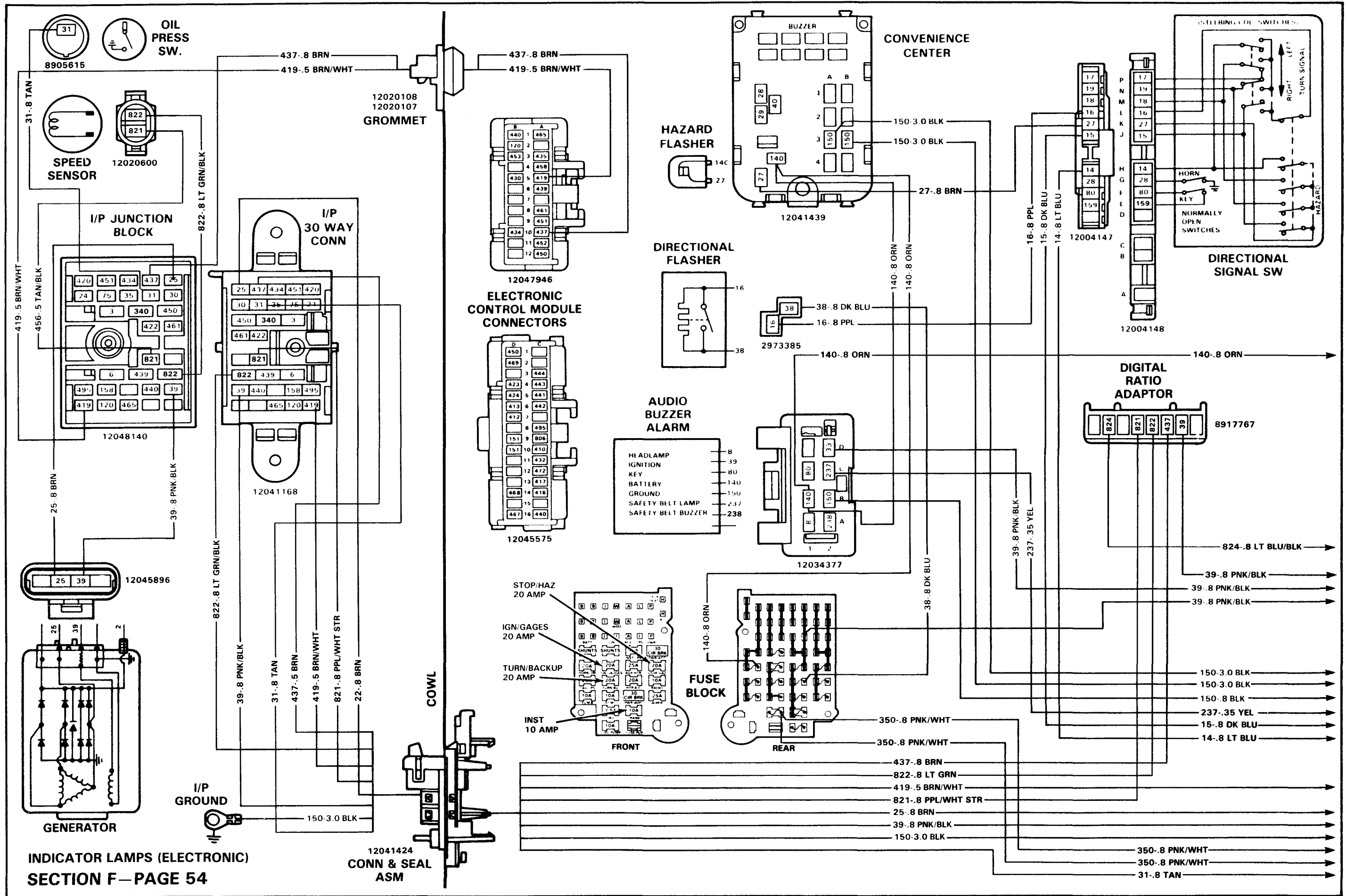

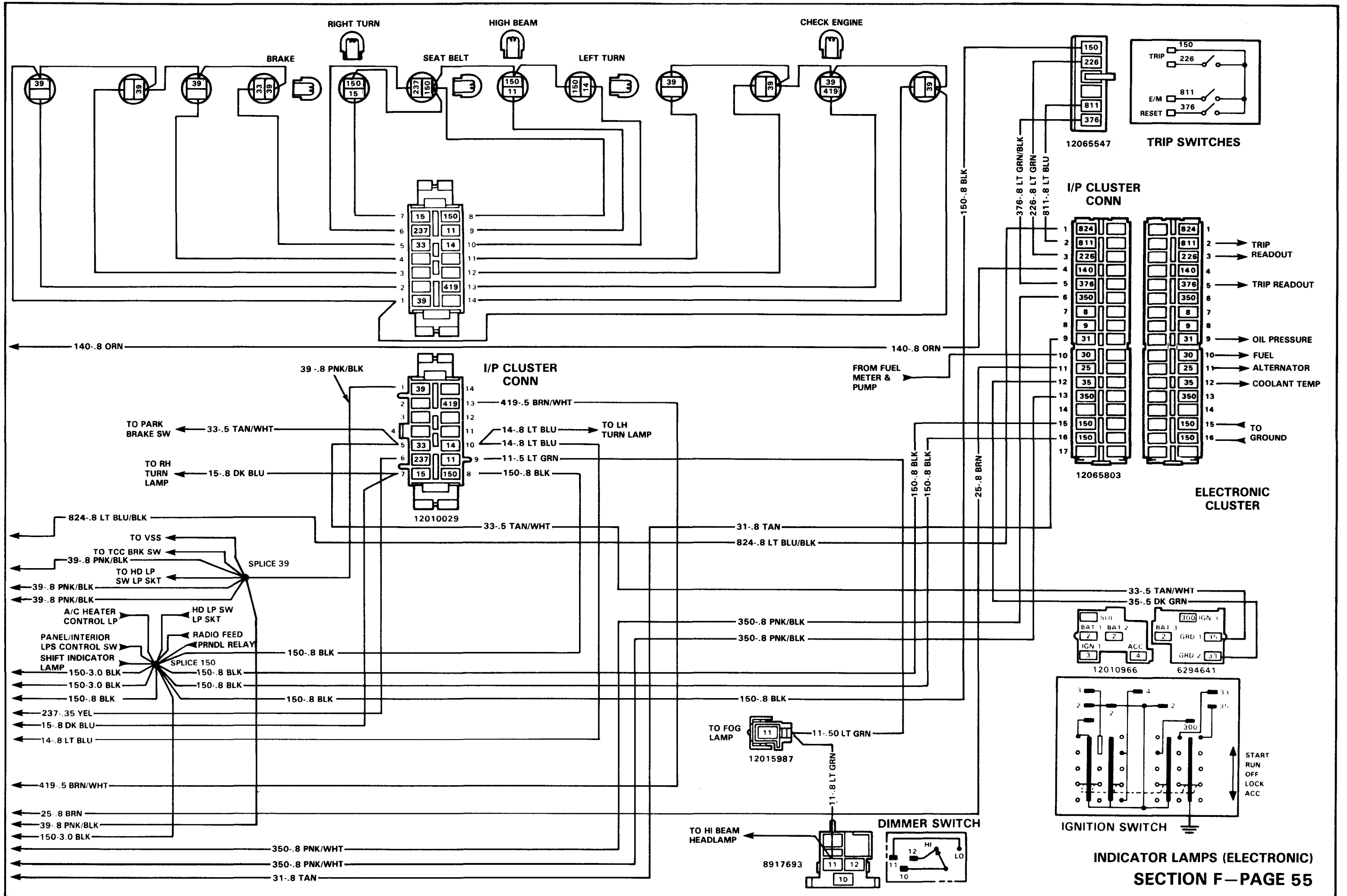

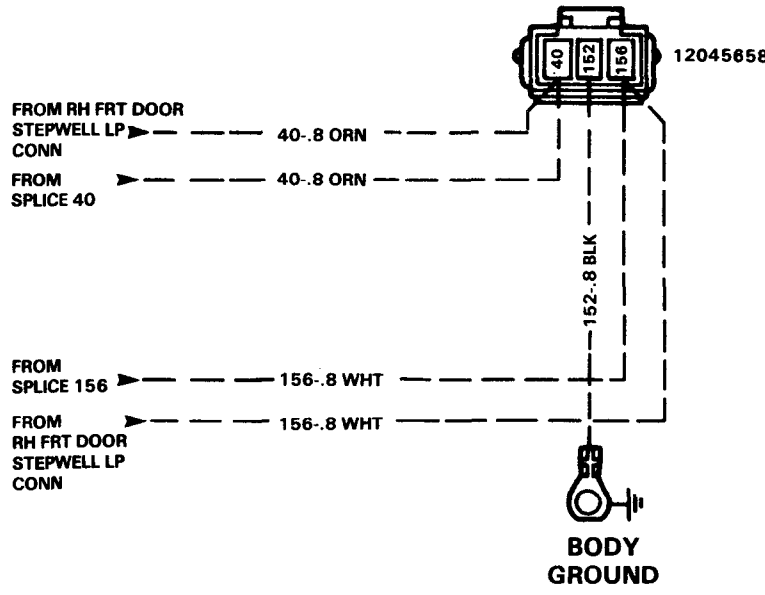
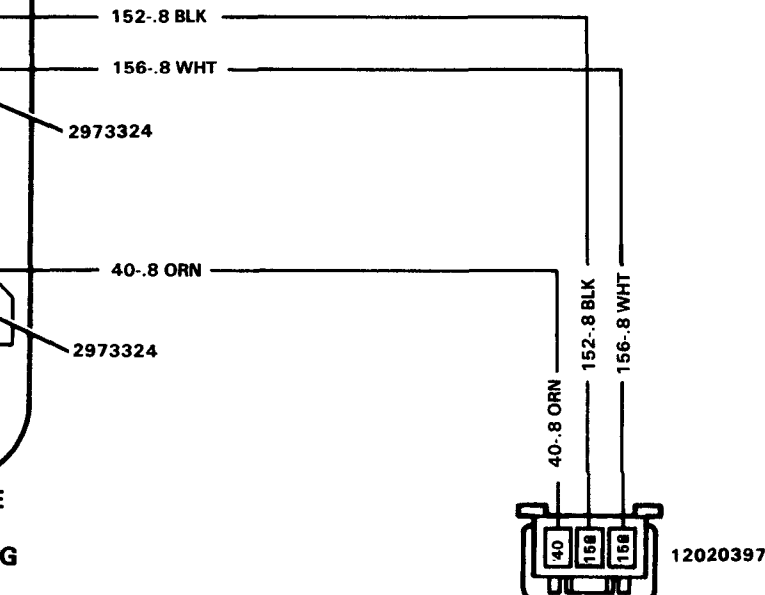
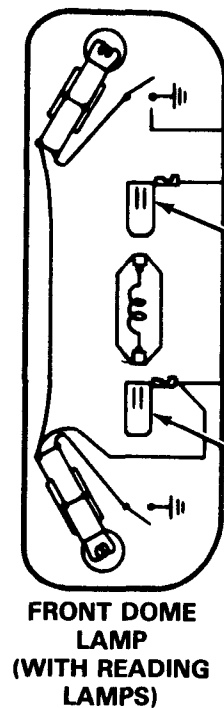

FOR CONTINUATION OF ROUTING, SEE LIGHTING PACKAGE RPO TR9 PG.#

LIGHTING PACKAGE (RPO C95)

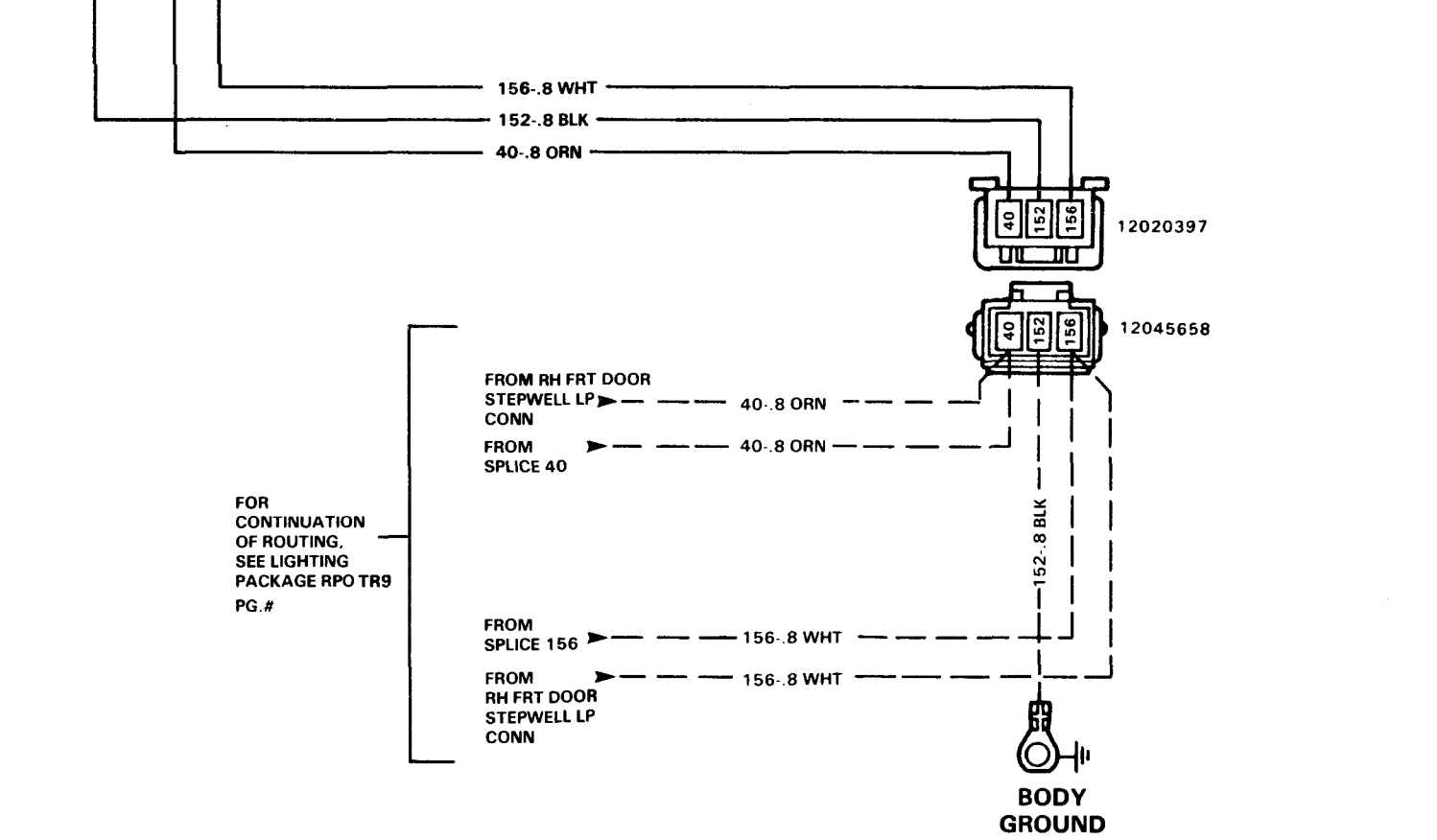
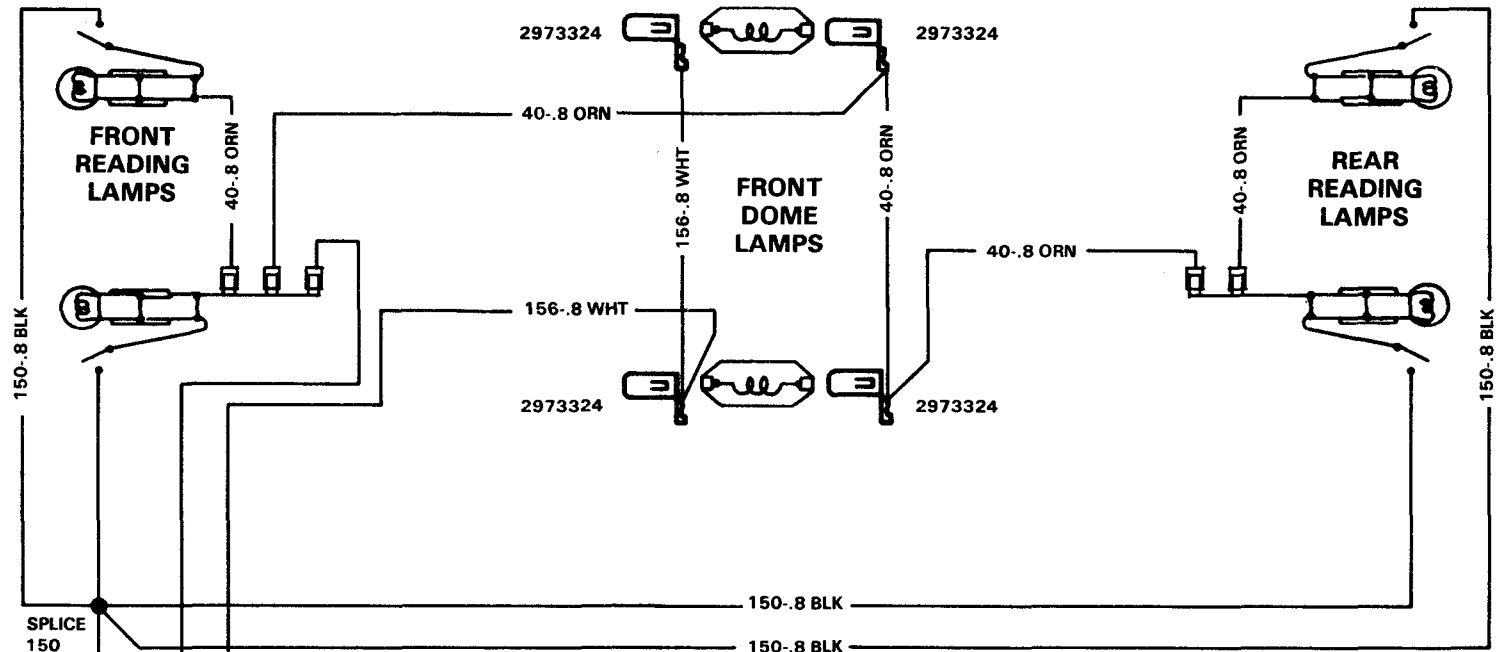

FOR CONTINUATION OF ROUTING, SEE LIGHTING PACKAGE RPO TR9 PG.#

LIGHTING PACKAGE ROOF CONSOLE (RPO DK6)

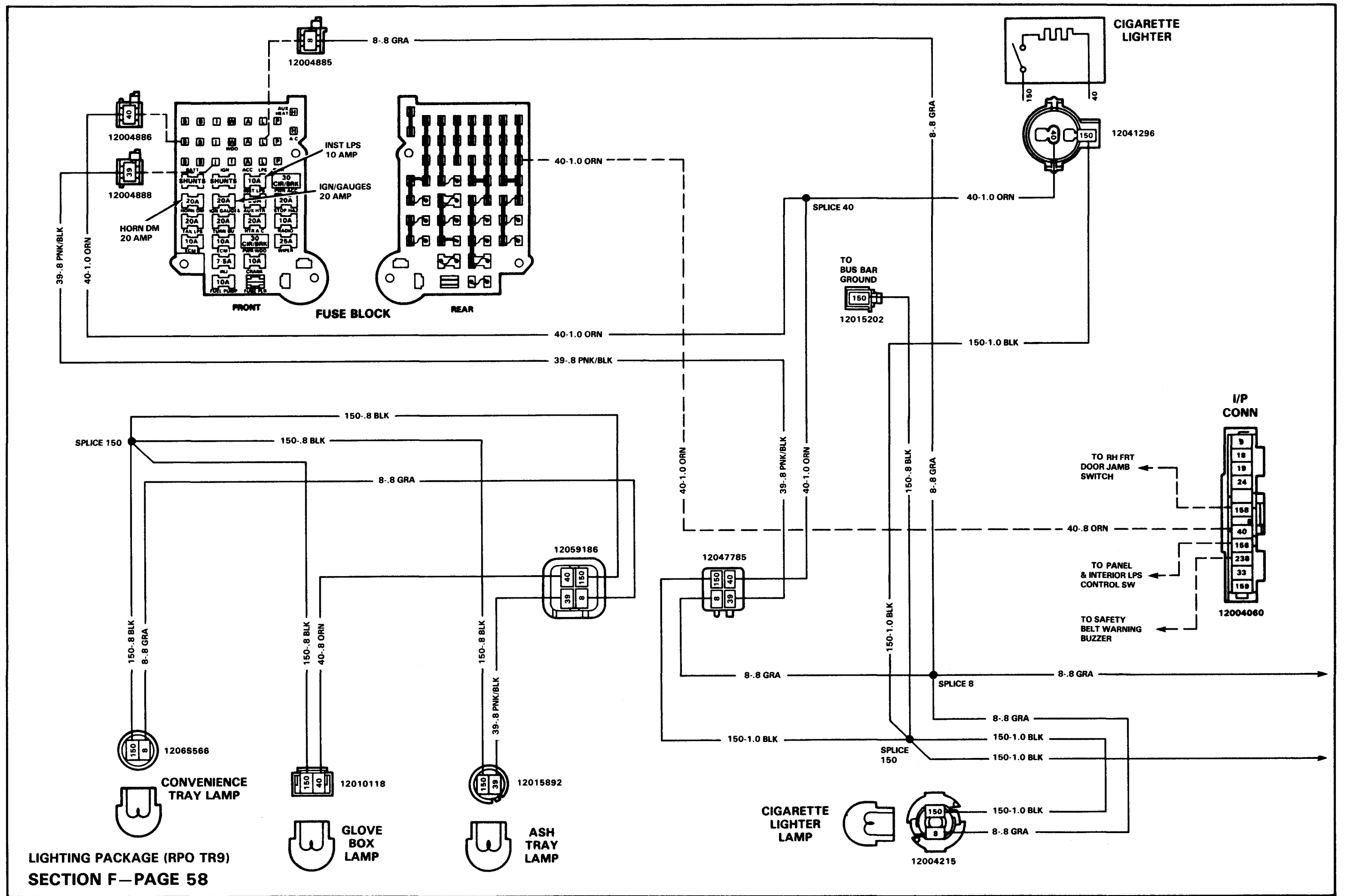

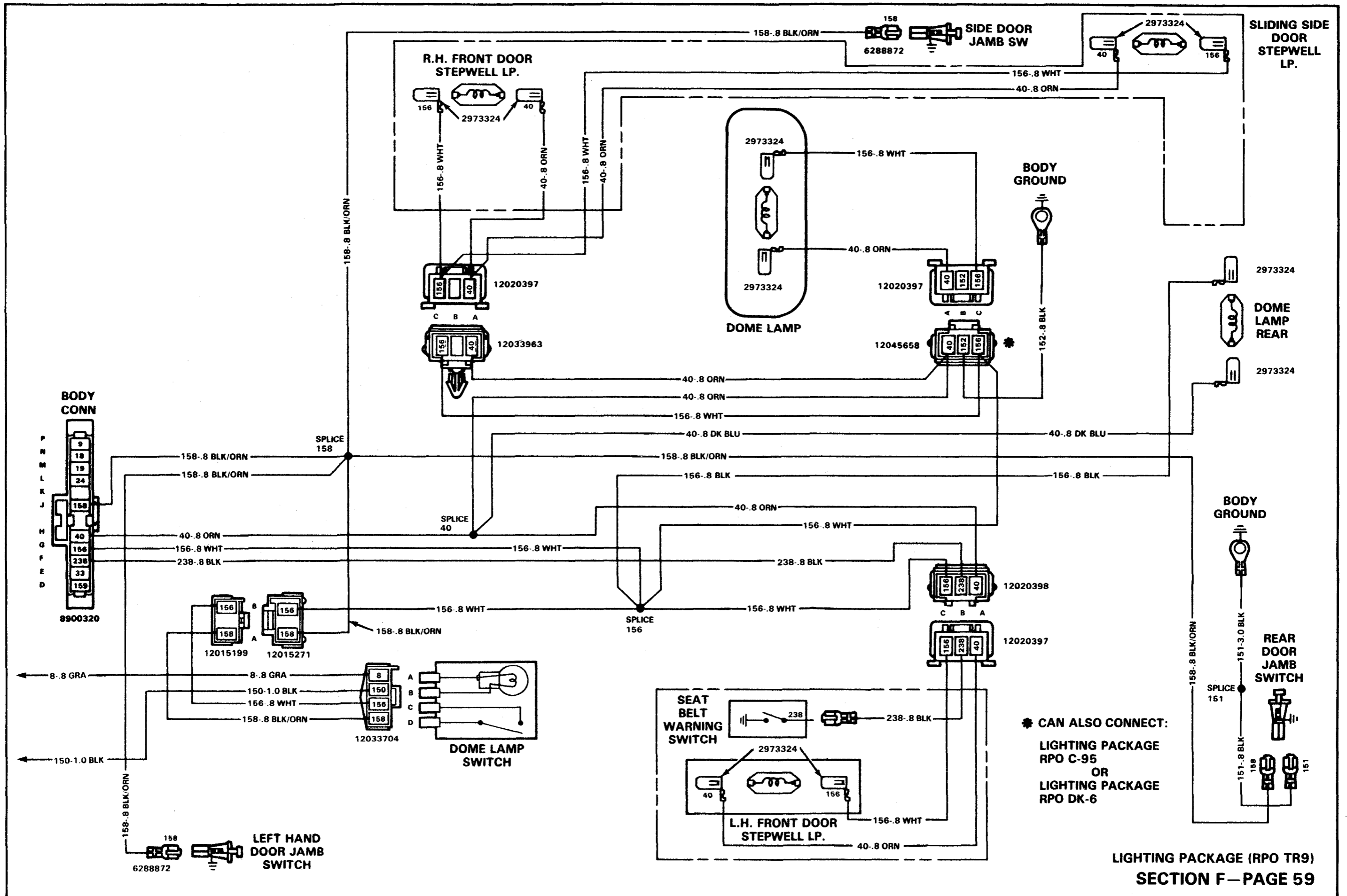

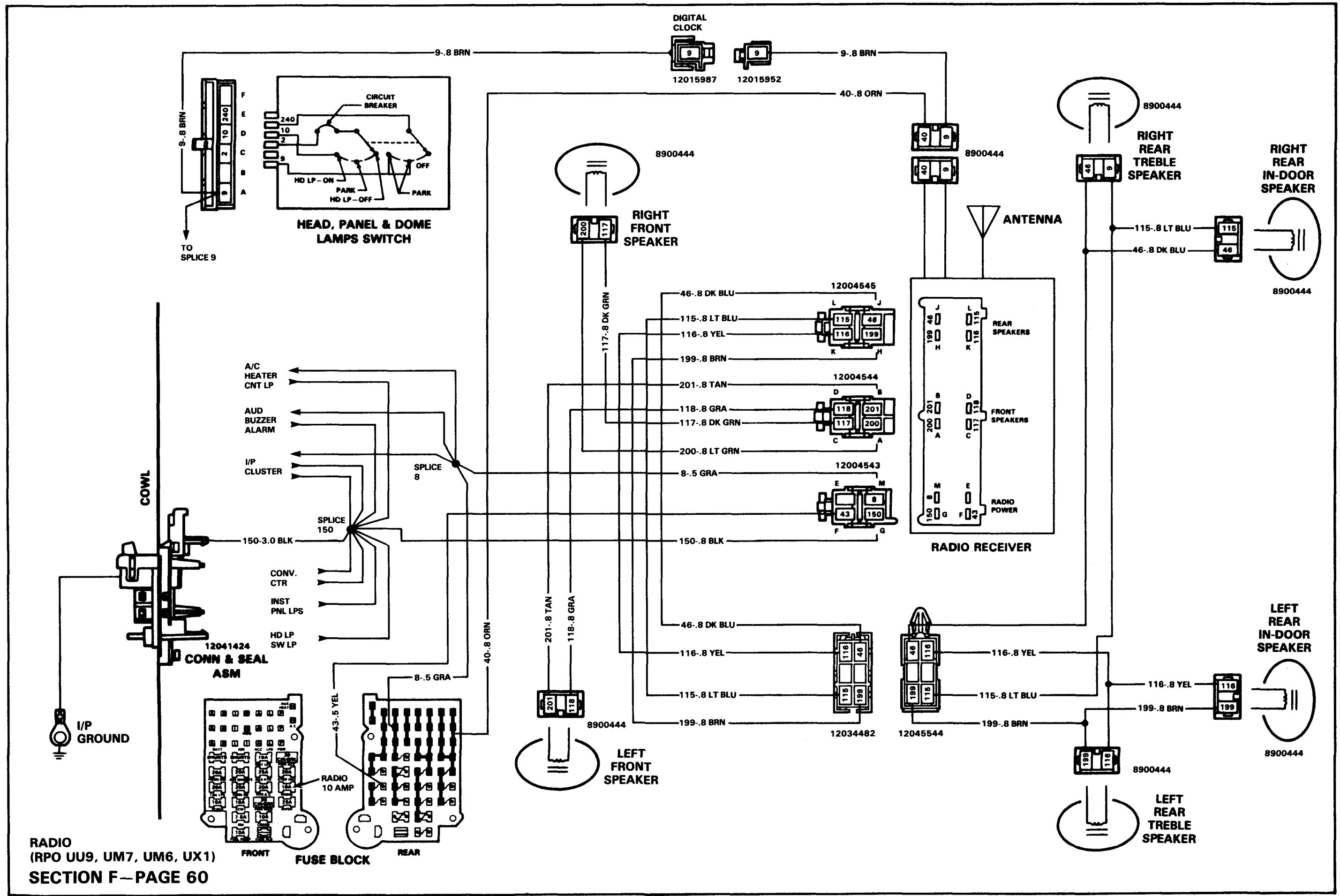

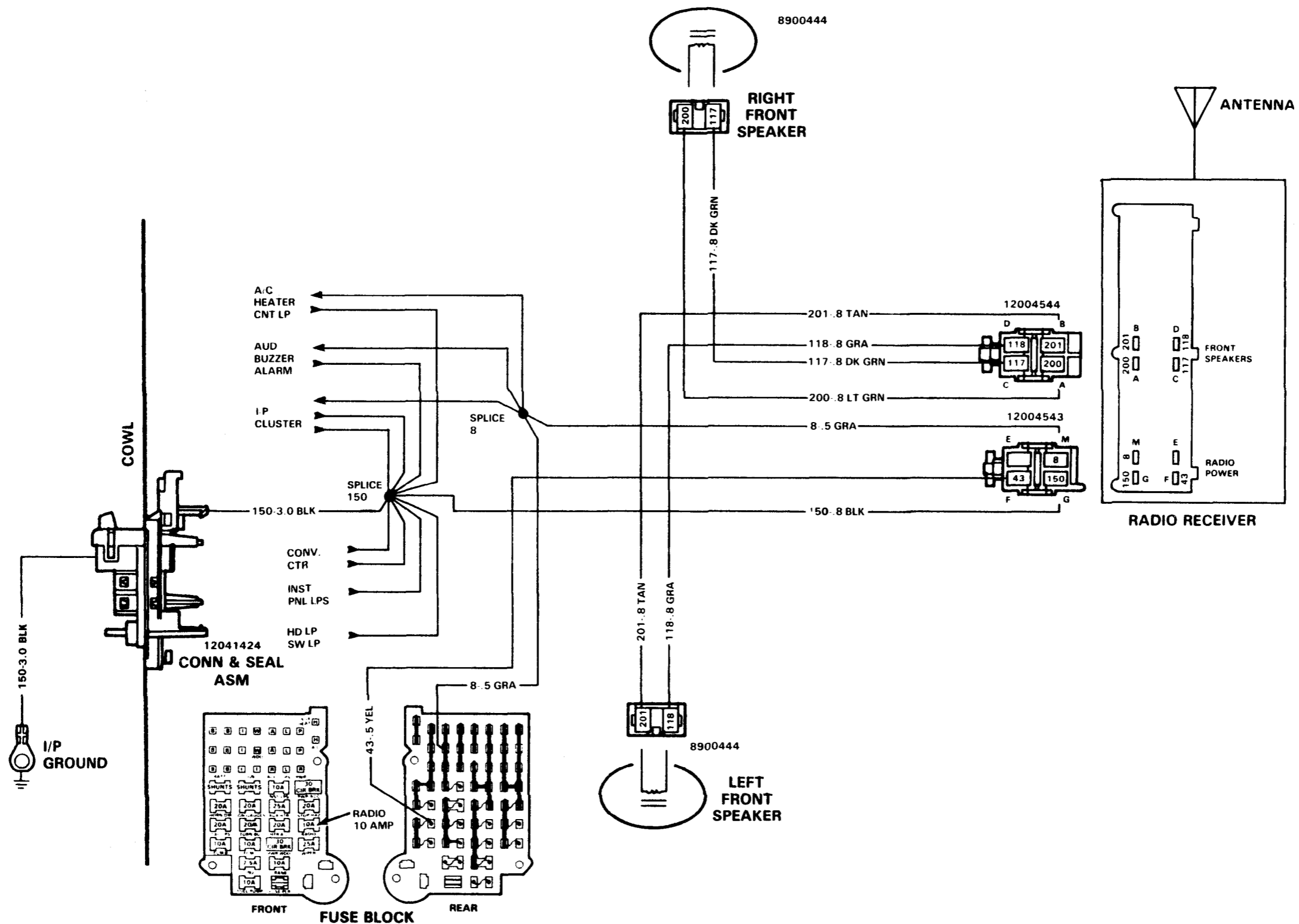

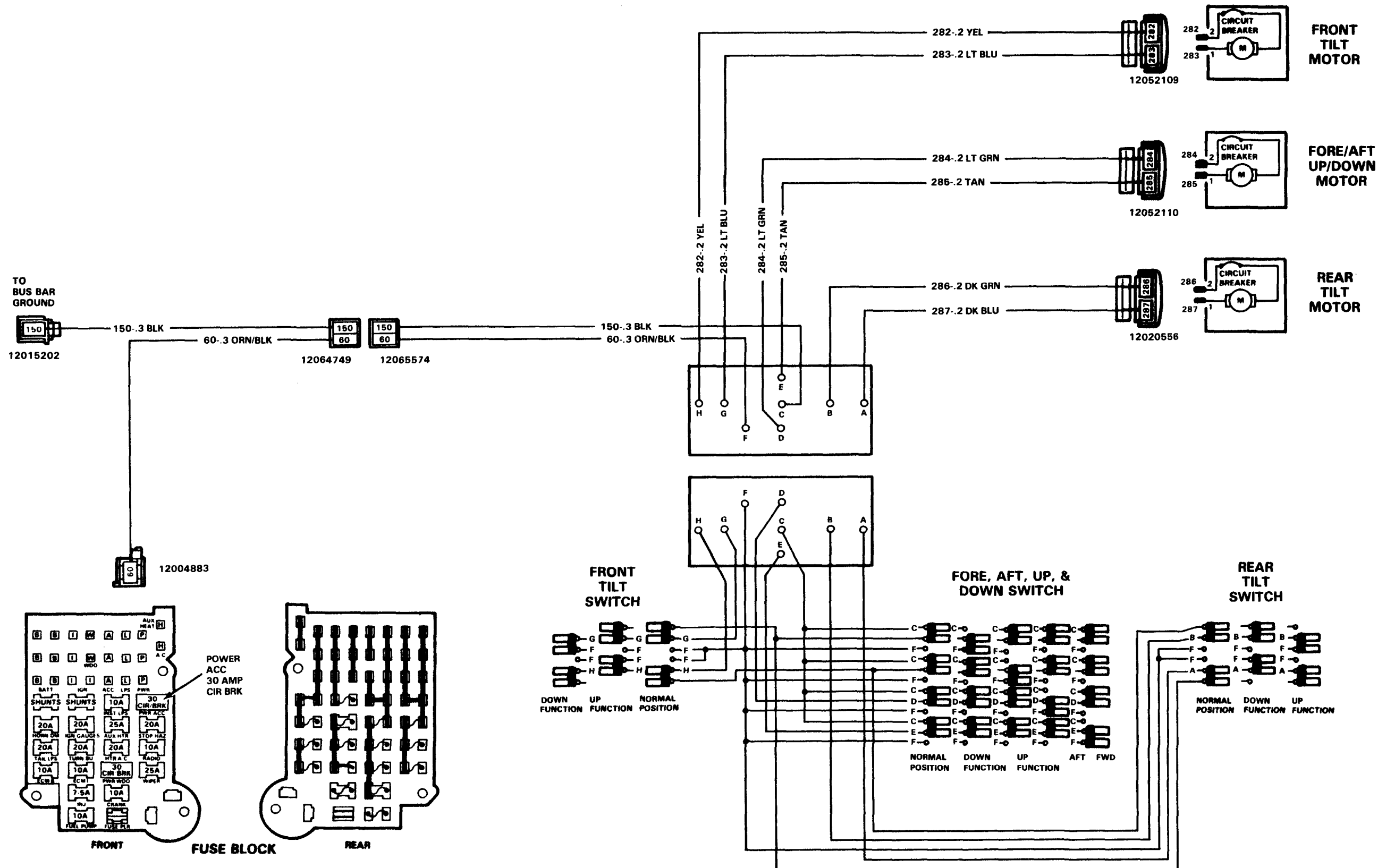

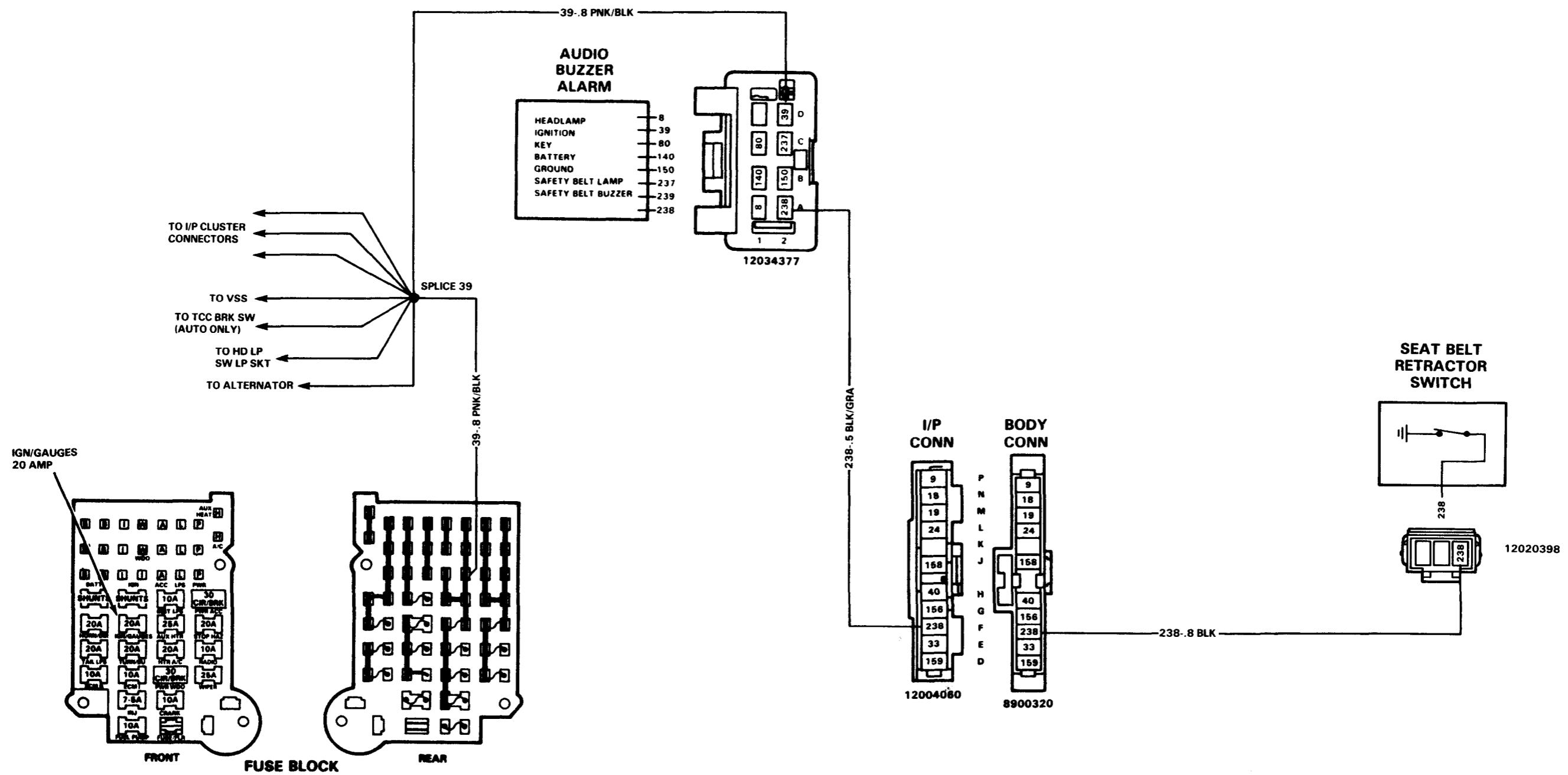

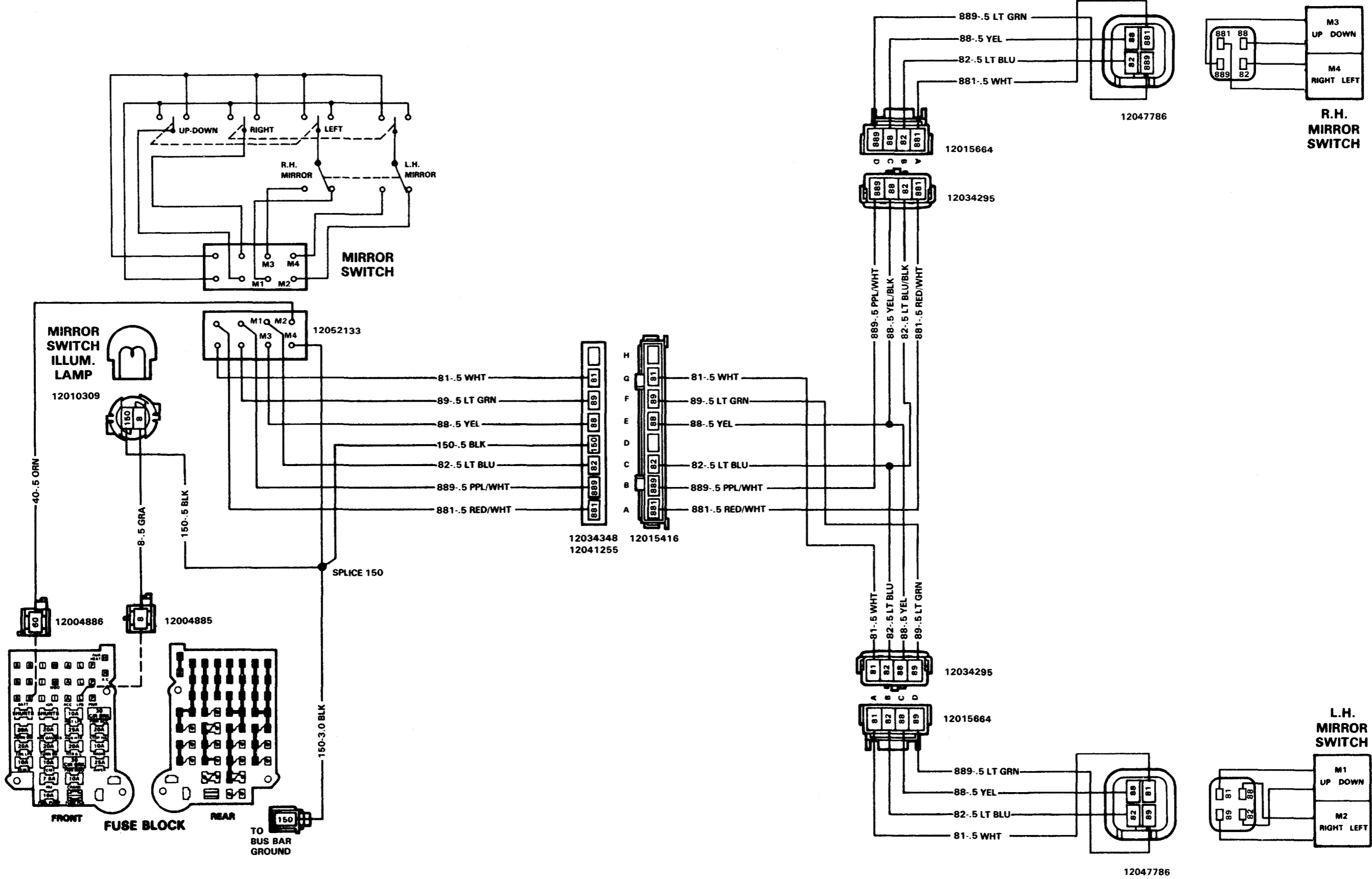

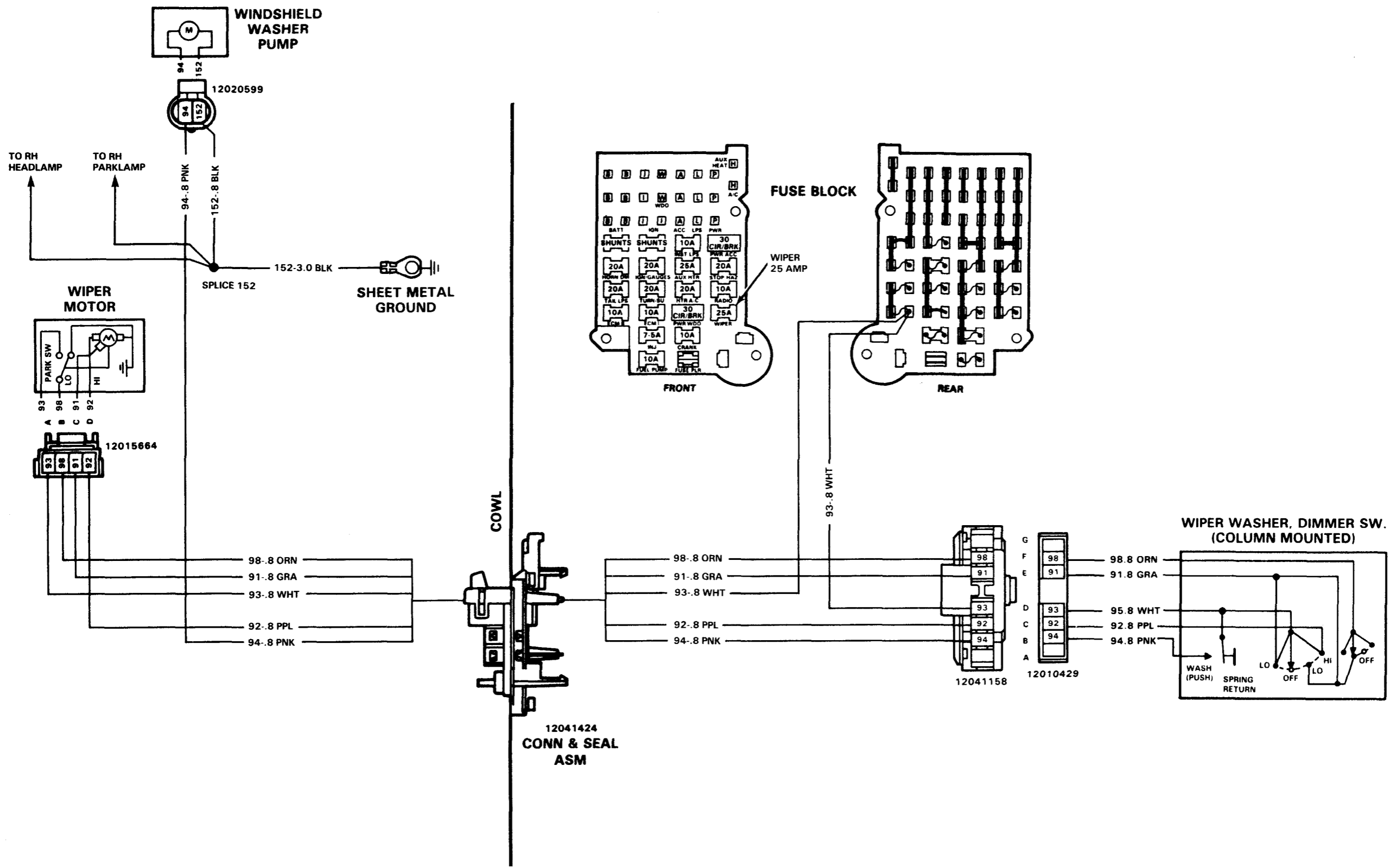

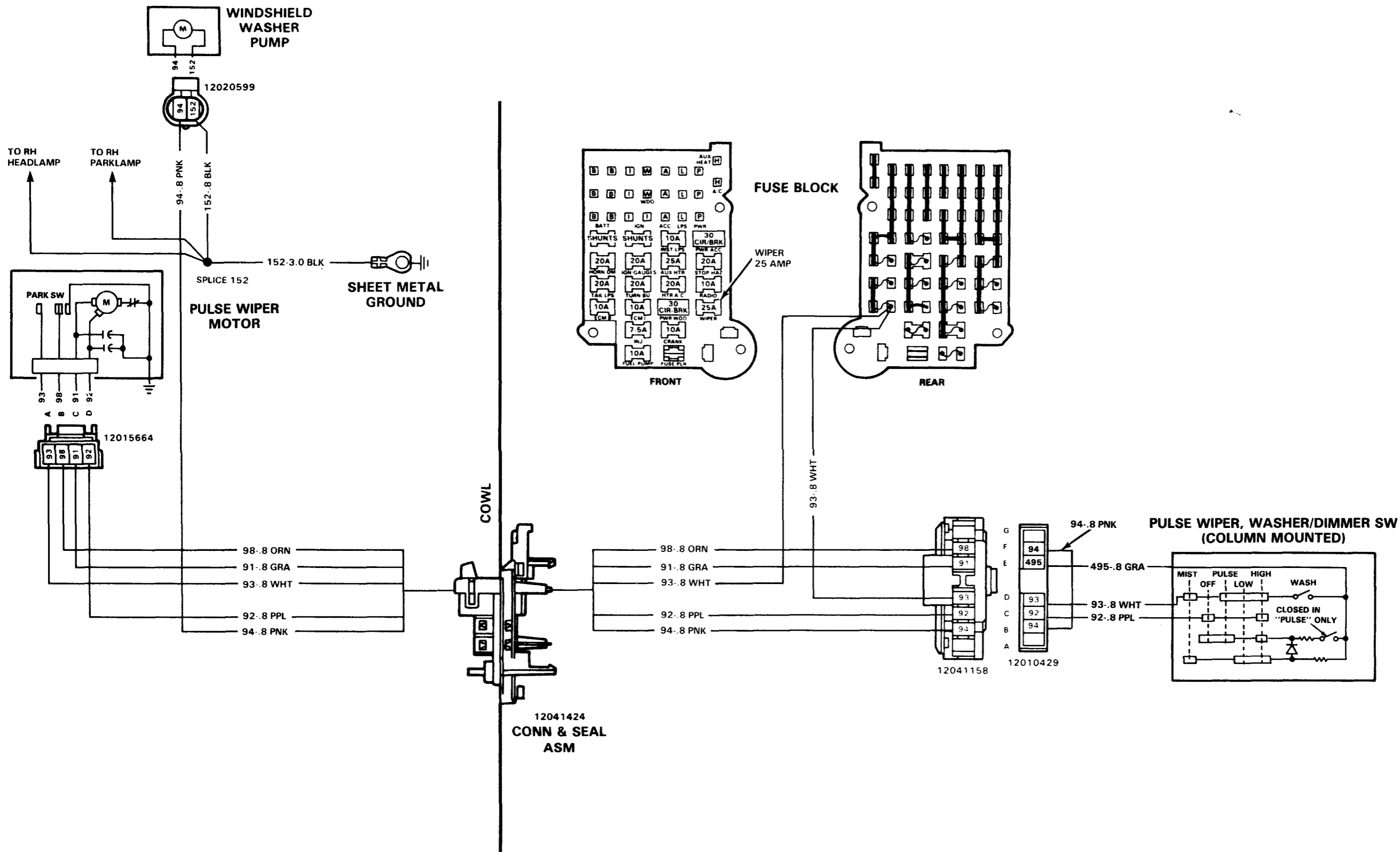

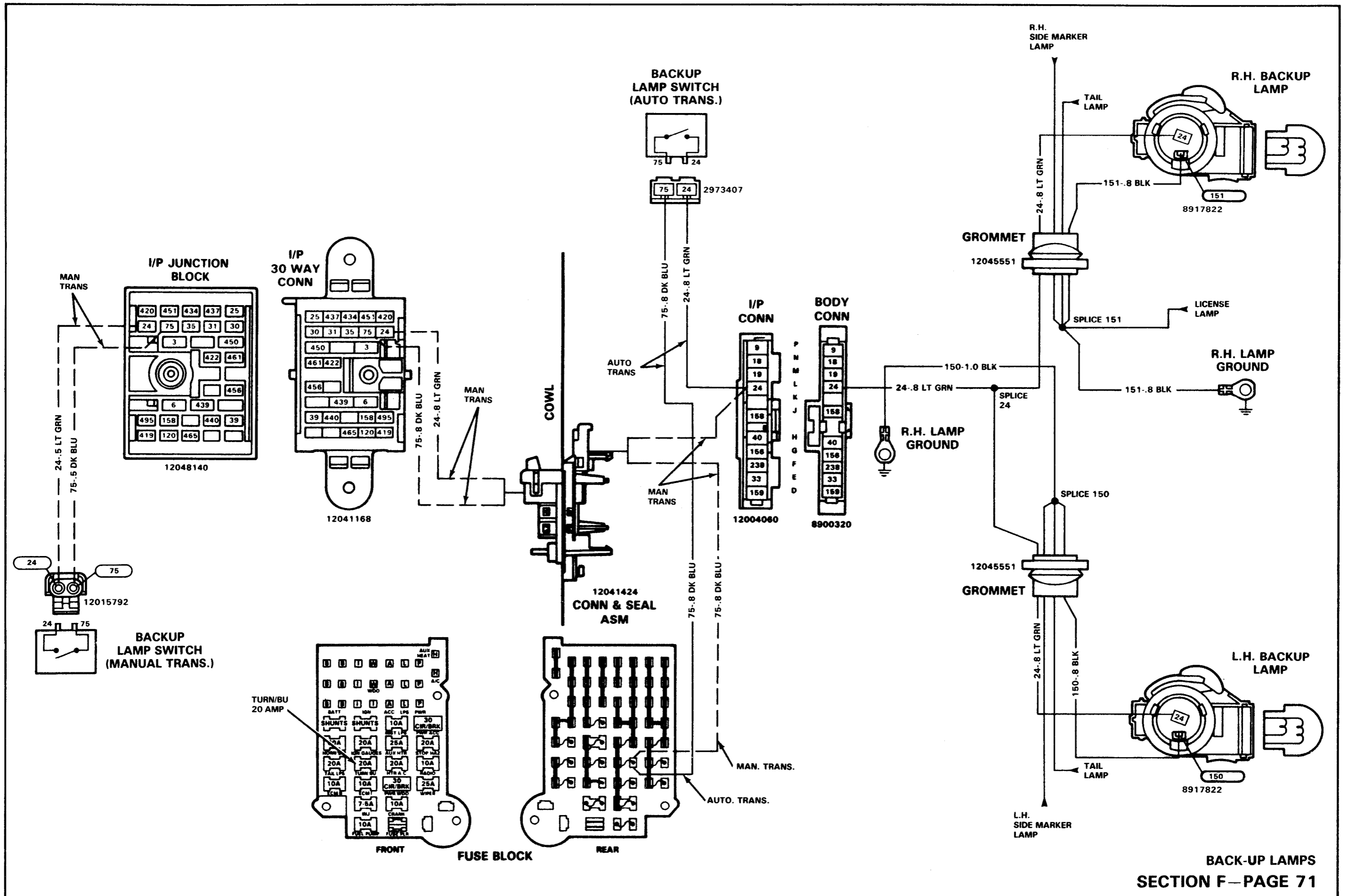

HEAD, PANEL & DOME LAMPS SWITCH

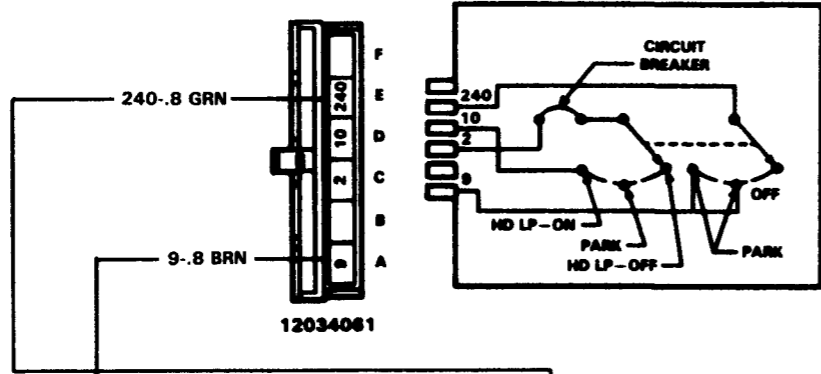

R.H. TAIL, STOP, & DIRECTIONAL LAMP

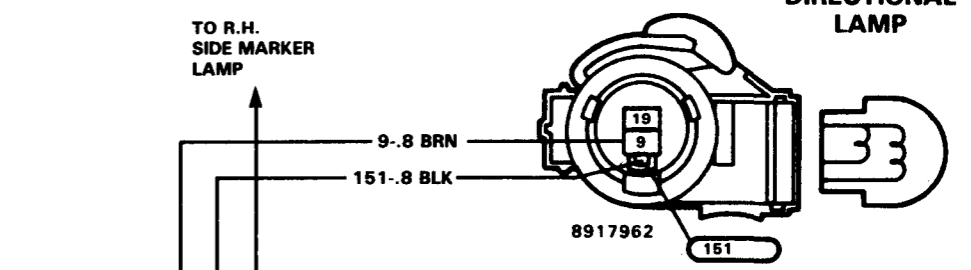

R.H. LAMP GROUND

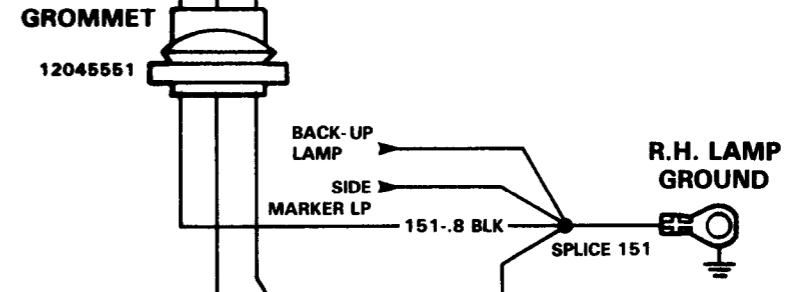

L.H. TAIL, STOP, & DIRECTIONAL LAMP

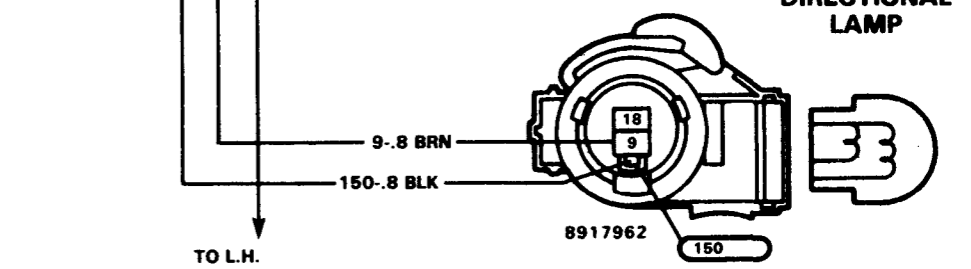

L.H. LAMP GROUND

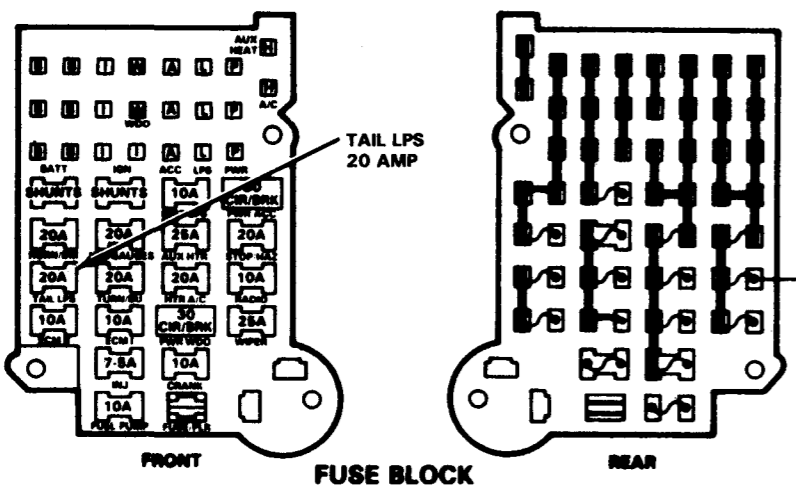
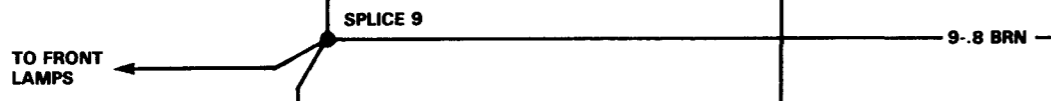
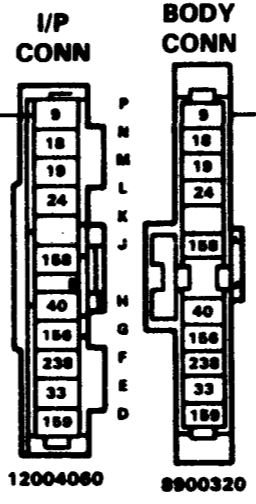
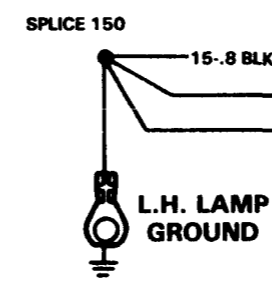

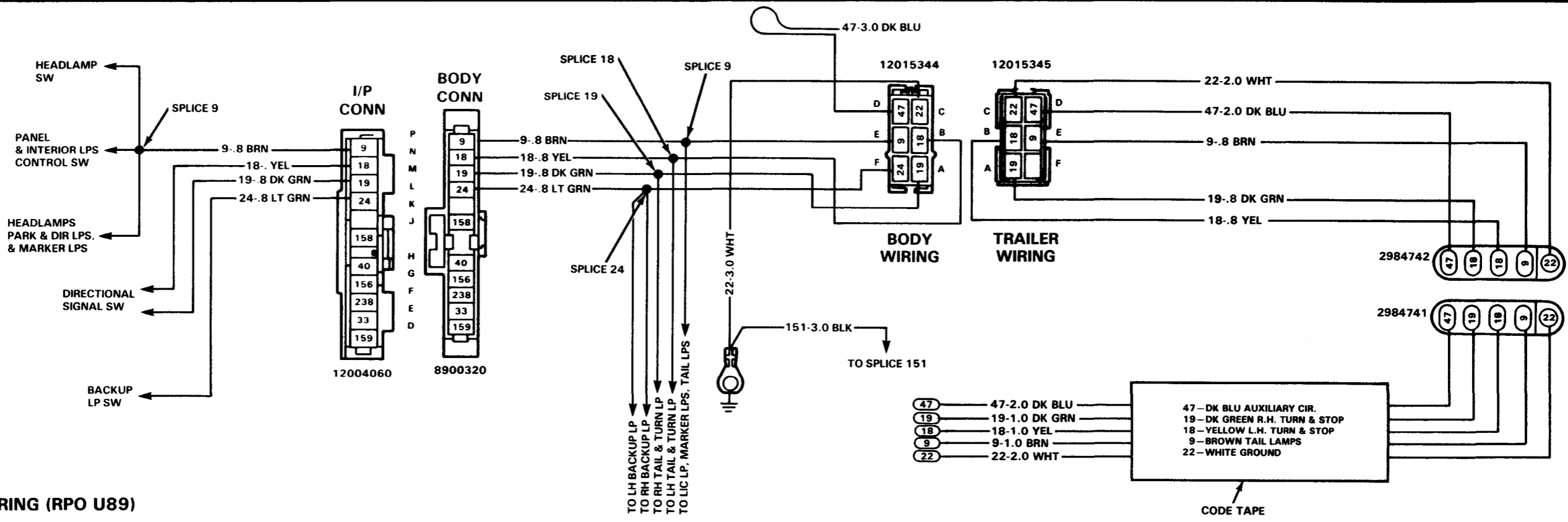

TRAILER WIRING (RPO U89)

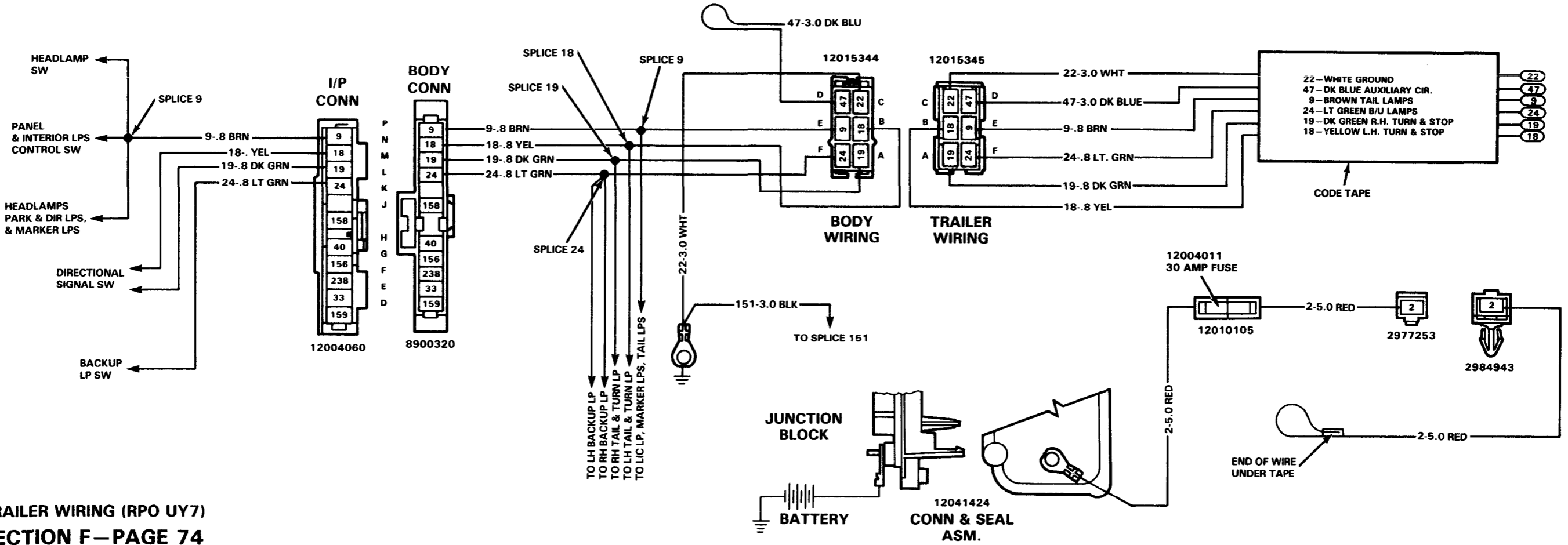

TRAILER WIRING (RPO UY7)
SECTION F—PAGE 74

